

**THE ROLE OF HEAT ASSISTED MAGNETIC RECORDING
IN FUTURE HARD DISK DRIVE APPLICATIONS**

by

Diego A. Méndez de la Luz

B. S. Mechanical and Electrical Engineering
Instituto Tecnológico y de Estudios Superiores de Monterrey, 2002

SUBMITTED TO THE
DEPARTMENT OF MATERIALS SCIENCE AND ENGINEERING
IN PARTIAL FULFILLMENT OF THE REQUIREMENTS FOR THE DEGREE OF
MASTER OF ENGINEERING IN MATERIALS SCIENCE AND ENGINEERING
AT THE
MASSACHUSETTS INSTITUTE OF TECHNOLOGY

SEPTEMBER, 2004

© 2004 Diego A. Méndez de la Luz. All rights reserved.

The author hereby grants the Massachusetts Institute of Technology
permission to reproduce and to distribute publicly paper and electronic
copies of this thesis document in whole or in part.

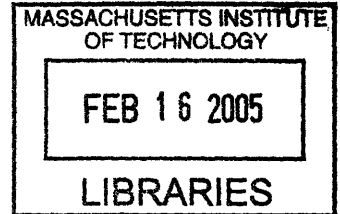

Signature of Author: _____
Department of Materials Science and Engineering
August 9, 2004

Certified by: _____
Robert C. O'Handley
Senior Research Scientist
Thesis Co-Advisor

Certified by: _____
Samuel M. Allen
POSCO Professor of Physical Metallurgy
Thesis Co-Advisor

Accepted by: _____
Carl V. Thompson II
Stavros Salapatas Professor of Materials Science and Engineering
Chair, Departmental Committee on Graduate Students

ARCHIVES

THE ROLE OF HEAT ASSISTED MAGNETIC RECORDING IN FUTURE HARD DISK DRIVE APPLICATIONS

by

Diego A. Méndez de la Luz

Submitted to the Department of Materials Science and Engineering
on August 9, 2004 in partial fulfillment of the requirements for the degree of
Master of Engineering in Materials Science and Engineering

Abstract

The magnetic recording industry keeps up with the demand of high capacity hard disk drives by improving the areal recording density of these devices. The use of conventional longitudinally magnetized media will be truncated by the challenges it faces nowadays, which are related to the instability of the stored information, produced by the aggressive decrease in the volume of the grains in the media. To overcome this problem, the use of large magnetic anisotropy energy density alloys is necessary, but the write fields that are required by such alloys can be prohibitively large, rendering these media effectively unwritable. Fortunately, the magnetocrystalline anisotropy energy density decreases with increasing temperature and so does the required write field.

Heat assisted magnetic recording allows the use of such magnetically hard alloys by using both a magnetic and a thermal field during the writing process. Research in HAMR is centered in three major fields: the heat delivery system, the magnetic recording media and the heat dissipation technology.

Based on an analysis of several US patents related to HAMR, one can see the real value of such patents is in negotiating and cross-licensing between companies to guarantee the right to participate in the manufacture of HDDs. Trade secrets and know-how are valuable assets for corporations. However, information exchange exists due to the great mobility of highly trained personnel between competing companies.

Because the basic application of HAMR is in supplying the computer industry with affordable storage devices, there is a well established market that makes the research efforts in HAMR advisable for individuals, universities and companies. Besides that traditional market, portable consumer electronics, such as PDAs, cell phones, music players, digital cameras, etc. make a relatively modest but fast growing market for ultrahigh areal density HAMR-based HDDs.

HAMR-based HDD for portable applications could very well be a disruptive technology in the magnetic recording industry. Companies that intend to profit from this technology need to invest on its development and must try to be first-to-volume production to benefit from economies of scale and to build the necessary expertise that could give them leadership roles in future magnetic recording.

Thesis Co-Advisor: Robert C. O'Handley
Title: Senior Research Scientist

Thesis Co-Advisor: Samuel M. Allen
Title: POSCO Professor of Physical Metallurgy

Acknowledgements

I had the opportunity to have Dr. Robert C. O'Handley both, as professor and as thesis co-advisor. He introduced me to the world of magnetic materials. I was able to enjoy his kind advice during my stay at MIT. Also as professor and thesis co-advisor, I had Samuel M. Allen, who shared his great knowledge with me. I am proud of having been part of the O'Handley-Allen Group.

I am fortunate enough to have my parents, Armando and Dulce, who have believed in me even before I myself did. With me at all times I have my dearly loved sisters, Nina and Dulce, who like me are starting a new and significant period in their life: best of lucks! I am privileged for having my aunt Emmita, who has been with me during all my education, during all my life.

Iliana knows how to make my life better everyday, even when having to put up with still one more separation. Remember the best part about going away is coming back.

I am also lucky of being part of MIT's Master of Engineering in Materials Science 2004 class: Lara Abbaschian, Alfredo Barradas, Stefano Bartolucci, Kristin Domike, Sarah Ibrahim, Julee Hong, Kevin Tibbetts, Brendan Wells, George Whitfield and Emily Zhang. I am especially thankful to Alfredo and Stefano for sharing a lot of working days and nights together. Congratulations to you all!

I need to thank Kermin Chok for being an example of hard work and dedication, but most importantly for being my friend.

I would finally like to thank Mexico's National Council of Science and Technology, CONACYT, for sponsoring my studies at the Massachusetts Institute of Technology.

Table of Contents

Abstract.....	2
Acknowledgements.....	3
Table of Contents.....	4
Index of figures.....	5
1 Introduction.....	8
1.1 The Hard Disk Drive.....	10
1.2 Longitudinal Magnetic Recording.....	14
1.3 Perpendicular Magnetic Recording.....	15
1.4 Areal Density: the 1 Tb/in ² goal.....	17
1.5 Current challenges in HDD technology.....	18
1.6 The Magnetic Recording Trilemma.....	22
2 Heat Assisted Perpendicular Magnetic Recording (HAMR).....	25
2.1 The principles of HAMR.....	25
2.2 Current research: Heating.....	26
2.3 Current research: Media.....	35
2.4 Heat dissipation.....	39
2.5 Summary.....	41
3 Intellectual Property Analysis.....	44
3.1 Patent Analysis.....	46
3.2 Summary.....	54
4 HAMR-based HDDs in the marketplace.....	57
4.1 Applications of HAMR.....	57
4.2 Market Assessment.....	59
4.3 Cost considerations.....	63
4.4 Economic challenges in HDD production.....	66
4.5 HAMR: disruptive technology?.....	67
4.6 Investment opportunities in HAMR.....	68

Index of figures

Figure 1-1 IBM's RAMAC, the first commercially available Hard Disk Drive.	9
Figure 1-2 Roadmap for magnetic storage devices.....	10
Figure 1-3 Schematic diagram showing the basic structure of a HDD.....	11
Figure 1-4 Hysteresis loops of irradiated and unirradiated FePt films.	12
Figure 1-5 Schematic of a read/write head for longitudinal magnetic recording	13
Figure 1-6 Read/write thin film head.....	14
Figure 1-7 Schematic of in-plane magnetized bits in a polycrystalline thin film.....	15
Figure 1-8 Comparison between the morphology of perpendicular and longitudinal magnetic recording systems.	16
Figure 1-9 Schematic of a read/write head for perpendicular magnetic recording.....	16
Figure 1-10 Progress of HDD and recording limit predictions.....	18
Figure 1-11 Comparison between the sizes of a slider and a passenger plane.....	19
Figure 1-12 Effect of bit size reduction on signal to noise ratio.....	20
Figure 1-13. Slater-Pauling curve showing moment per atom (in Bohr magnetons)	22
Figure 1-14: Magnetic recording "trilemma"..	23
Figure 2-1 Temperature dependence of coercivity and remanent magnetization in a typical magnetic recording medium.....	25
Figure 2-2. Minimum full width at half maximum spot diameter vs. source light wavelength for different SIL materials	29
Figure 2-3. Thin film structure to induce surface plasmons. Ion-milled apertures on a gold layer.....	30
Figure 2-4 Pyramidal Si probes fabricated using AFM-tip technology.....	31
Figure 2-5. Bits recorded using an AFM tip as heating device.	33
Figure 2-6. Three possible configurations to achieve small size bits without having bit- size magnetic and thermal fields.....	35
Figure 2-7: VSM hysteresis loops for Co-Pd film.	37
Figure 2-8: Reversibility in write field, H_c , and saturation magnetization, M_s , with temperature. CoPt thin film.....	37
Figure 2-9: Transmission electron micrographs of the $(\text{FePt})_{1-x}\text{C}_x$ system	39

Figure 2-10: Effect of heat sink layer on the magnetic domain patterns at different bit size scales	40
Figure 3-1: Typical setup of a HDD, showing main components.	44
Figure 3-2: technologies involved in the development and production of HDDs.	45
Figure 3-3. Near-field focusing structure protected by US patent 6,714,370.....	47
Figure 3-4. Slider with an integrated laser diode protected by US patent 6,762,977.	48
Figure 3-5. Microfabrication method for the slider claimed in US patent 6,762,977.....	49
Figure 3-6. HAMR slider. Protected by US patent 6,636,460.....	50
Figure 3-7. antiferromagnetically coupled medium protected by US patent 6,603,619 ...	52
Figure 3-8. Schematic of a HAMR slider using an electron beam as the heat source.....	53
Figure 4-1. IBM's 5Gb Compact Flash hard drive:.....	57
Figure 4-2: Portable applications for HDDs.	58
Figure 4-3 Market share of major HDD manufacturers.....	60
Figure 4-4. Hitachi Global Storage Technologies' 4 Gb CF HDD.....	60
Figure 4-5 Rigid disk media market shares 4 th quarter 2003.	61
Figure 4-6 Growth of market for mobile applications of HDDs.	62
Figure 4-7 Growth of market segment for non-traditional applications for HDDs	63
Figure 4-8 Christensen's map of success for startups in the HDD industry.....	65
Figure 4-9 Roadmap of the HDD industry.	66
Figure 4-10 Development of price per megabyte vs. total produced HDD capacity.	66
Figure 4-11 Disruptive changes in HDD architectures.....	67

*“Studying magnetic materials is probably
the best way of understanding materials science”*

Dr. Robert C. O’Handley

1 Introduction

Magnetic storage has played a key role in audio, video, and computer developments since it was first introduced in 1898 by the Danish telephone and telegraph engineer Valdemar Poulsen [1]. The principles of magnetic recording were described admirably by Oberlin Smith in 1878. But it was not until 1898 that a device using these principles was demonstrated and patented by the inventor, V. Poulsen [2].

Form the original invention by Poulsen, there are four formats in which magnetic recording survives to this day. These four enduring product formats: the Magnetophon audio recorder, the quadruplex video recorder, the RAMAC disk file, and the diskette, have evolved into their present forms: plastic magnetic tape recording, vhs and beta video recording technology, the hard disk drive (HDD) and the floppy disk drive [2]. Recently, magnetic random access memory (MRAM) has been introduced to the marketplace and is a very promising technology. However, this document concentrates on the current improvement of HDDs.

Magnetic materials are the primary medium by which information is currently stored in today's computers. Perhaps because magnetic recording is the most economical means of data storage, hard disk drives provide almost half of all computer storage [3]. As a mater of fact, the improvements in magnetic recording technology have not only kept up with the increase in performance seen in the personal computer industry, but have actually made it possible, surpassing at some points the rate of growth of the semiconductor industry [3]. We can safely say that magnetic recording technologies, specifically HDDs, have played a role as important as the microprocessor in the continuous betterment of information technologies.

The history of magnetic recording goes back almost 50 years. It was in June 1957 that IBM shipped the first RAMAC, a product that began to change the way people stored information in computational systems. The so-called random access method for accounting and control (RAMAC) contained the first commercial disk drive, the IBM 350. In fact, there were thirty of these 24 inch diameter disks in every RAMAC unit, for a total combined capacity of 5 Mb [2]. The recording density, defined as the number of bits per surface area on the HDDs surface, was only of 2 kbits/in² and each unit sold for

roughly \$100,000 [3]. In fact, the price was the so high that IBM had to provide an information storage space rental service for the users, as a way of making the technology affordable, and thus, attractive to costumers.



Figure 1-1 A perspective of IBM's RAMAC, the first commercially available Hard Disk Drive. The units contained 50 24-inch disks in which a total of 5Mb of information could be stored.

Each RAMAC unit occupied a space of about 1 million cubic centimeters (1 cubic meter), and it achieved a storage density of 3 bits per square millimeter (1935 bit/in²). A modern disk drive occupies less than 100 cubic centimeters and stores data at a density of more than 100 million bits per square millimeter (70 Gbit/in²), an improvement in areal density corresponding to a factor of over 10 million. On a bits-per-unit-volume basis, the improvement is quite spectacular – a factor over 100 million. Today the hard disk drive has the highest areal density of any magnetic recording device [2].

RAMAC technology used a read/write head that was supported by a pressurized air bearing. The introduction of such system allowed for reduced head-to-disk spacing and thus allowed an areal density that was considered revolutionary.

Figure 1-2 shows the roadmap for magnetic storage devices in the last half a century. From 1957 to 1991 the average growth rate was 39% per annum. In 1991, due to the introduction of Giant-Magneto-Resistive (GMR) heads, the slope of the curve changed to an annual average increase of 65% from 1991 to 1997 [2]. However, in the last few years

this rate has dropped to roughly 40% a year due to the challenges that the magnetic recording industry has had to face.

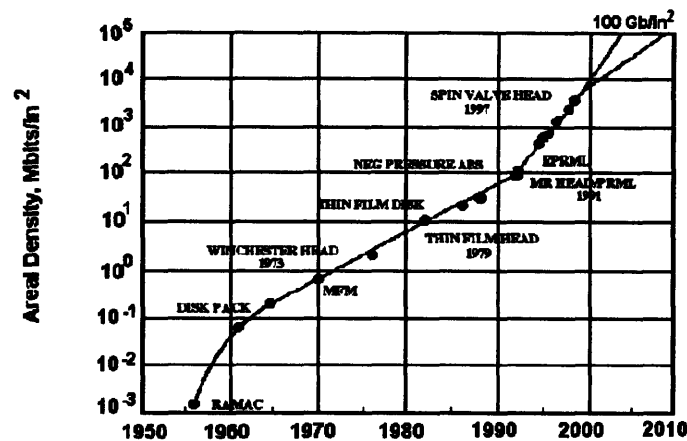

Figure 1-2 Roadmap for magnetic storage devices. The 100 Gb/in² is the lower limit for the goals set towards year 2010.

Regardless of the great increase in performance shown by HDD technology, the price of hard disk storage has been decreasing rapidly, from about \$200 per megabyte in 1980 to less than 1 cent per megabyte today. This reduction in price has been primarily due to the downward scaling in the size of the magnetic storage cell, which has allowed larger capacities in the memory devices [4].

1.1 The Hard Disk Drive

Today's HDDs contains two 1.8-3.5" diameter disks with a total capacity of 10-60Gb at a cost of less than \$200. Disks have various formats, depending on the application, but are usually 3.5" or 2.5" in diameter for desktop applications and 1.8" for laptop computers, in which space is limited.

There basic two parts to a hard drive unit are the disk and the read/write head. Other components involve signal processing units, head positioning (servo) mechanisms, the spindle casing, etc. However, it is the head and the disk that are of greatest interest from the magnetic materials point of view.

1.1.1 The disk

The disk's substrate is made of glass or some aluminum alloy, and varies in thickness from 1.25 to 0.5 mm depending on the disk diameter. Rotational speeds

nowadays exceed 10,000 rpm and require stronger, harder, stiffer and lighter substrates. Non-metallic materials are thus currently of great interest.

The topology of the disks includes several layers as can be seen in Figure 1-3. The first layer promotes a flat surface in the finished disk. This is usually a non magnetic, mechanically hard coating. This first layer used to be textured to promote different magnetic characteristics in the circumferential and radial directions. Recently, the reduction in fly height (head-to-disc spacing) has imposed very strict requirements on surface roughness and texturing has been abandoned.

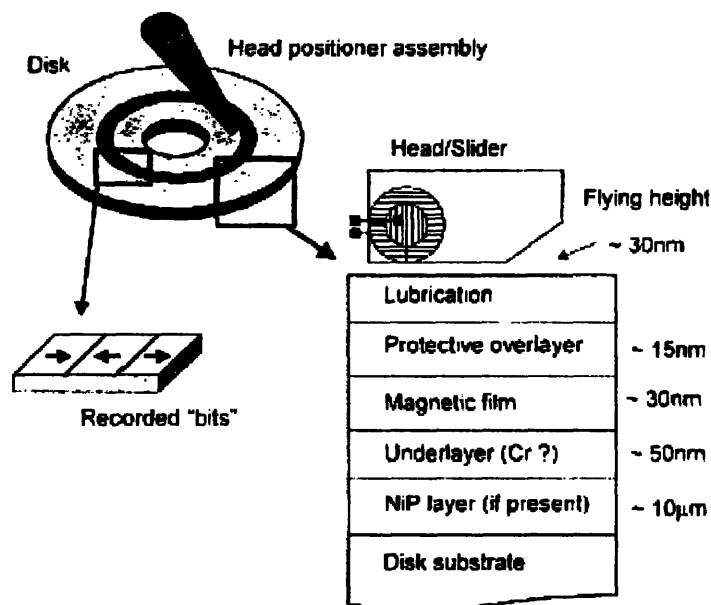

Figure 1-3 Schematic diagram showing the basic structure of a HDD, the layers forming the media and a section of a track with bits recorded onto it [3].

The underlayer can act as a seed layer and promote the growth of the magnetic film in a desired orientation. Normally a material is chosen due to its lattice parameters, which can promote the preferential alignment of subsequent layers in such an orientation that magnetic functionality is optimized.

The magnetic layer normally exhibits a large coercivity, high enough for it to keep its magnetization state but moderate enough to allow the writing process. High values of coercivity, saturation magnetization, remanent magnetization and magnetocrystalline

anisotropy are preferred for high-recording-density uses. The squareness of the magnetic hysteresis loop, designated S , is a characteristic that can be a very good measure of the functionality of a magnetic layer for magnetic recording purposes. Figure 1-4 compares two different hysteresis loops. Both have been measured from samples of FePt thin films. As can be seen from the figure, the squareness of the ion-irradiated film is greater than the one for the unirradiated sample, making this first film more suitable for a high areal density system.

Modern magnetic media can consist of more than one magnetic layer. Anti-Ferromagnetically-Coupled (AFC) media use one or two layers to act to stabilize the magnetization state of the main magnetic layer.

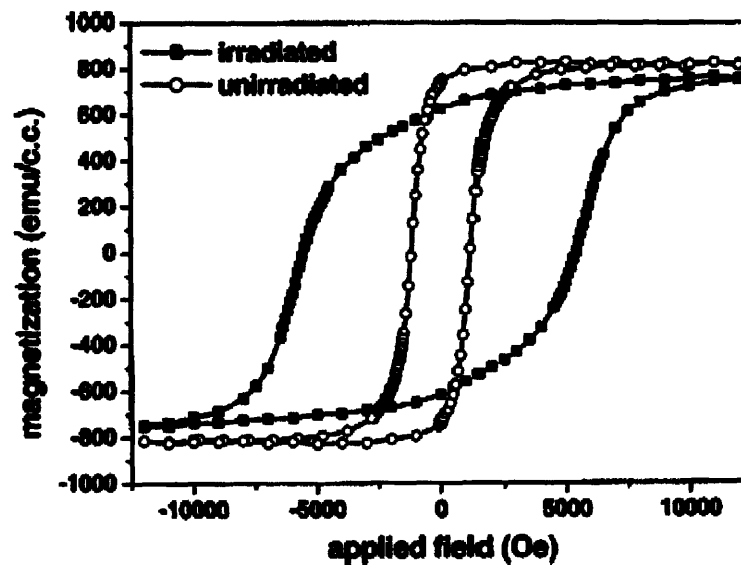

Figure 1-4 Hysteresis loops of irradiated and unirradiated FePt films. Ion-irradiated film shows higher squareness in its loop shape. This accounts for relatively high values of coercivity, remanent magnetization and magnetocrystalline anisotropy. [5]

The protective layer is typically non-magnetic and it is very hard to protect the storage layer from physical damage. 'Modified' carbon layers are often used for this purpose. The diamond-like arrangement of the atoms that is achieved in such films provides the hardness that is necessary to prevent the damage of the magnetic layers and the consequent introduction of debris.

The lubricating layer acts as a complimentary mechanism of protection. It is made of a relatively high molecular weight linear polymer. The coating is usually of monolayer thickness and binds to the carbon atoms by interactions between the groups in the linear polymer and the carbon surface. Typical lubricants are perfluoropolyethers with molecular weights of 2000 and more.

1.1.2 The head

Read and write heads are normally incorporated in a single structure. Thin film technology has made great impact in the production of read/write heads. An image of a magnetic read/write head is shown in Figure 1-5. When a current flows in the coil that surrounds the write element, it induces a magnetic field in the gap, which can modify the magnetization state of the underlying thin film.

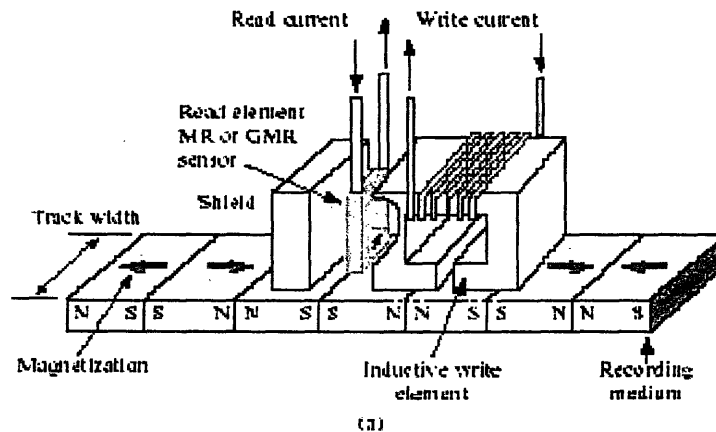

Figure 1-5 Schematic of a read/write magnetic recording head (for longitudinal recording). The stray field from the write gap induces a field on the magnetic film. The magnetoresistive element senses the transitions between adjacent bits of opposite magnetization state. [6]

Since their introduction in 1991, magnetoresistive heads have been the technology of choice in commercially available hard drives. The most obvious advantage of this type of head is that it is much more sensitive than inductive heads because it senses directly the magnetic field that emanates from the recording bits, as opposed to the induced current on a pickup coil.

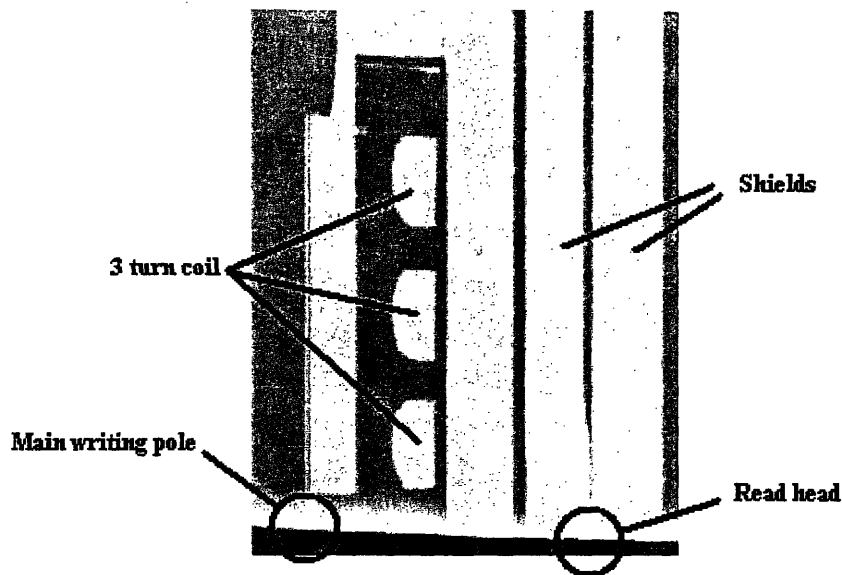

Figure 1-6 Read/write thin film head. Featuring a 2.4 T main pole and a three-turn inductive coil. [7]

1.2 Longitudinal Magnetic Recording

Longitudinally magnetized media has been used in magnetic recording since the first HDDs were designed. In this configuration, the magnetization of the recording bits lies within the plane of the film and information is read by measuring the stray field above the film at regularly spaced intervals. Unfortunately, in this configuration there is an unavoidable problem: the bits have a tendency to demagnetize themselves whenever two regions of opposite magnetization are placed next to each other (see Figure 1-7).

As seen in Figure 1-2, longitudinal magnetic recording has already made possible a growth in areal density of nearly 8 orders of magnitude. Figure 1-7 shows an image of in-plane magnetized bits. In polycrystalline films such as the ones used in today's media, the otherwise random orientation of the magnetization in each grain is aligned to the easy direction that has the largest component parallel to the direction of the applied field. The vector summation of all the magnetizations in a bit results in a net magnetization of the magnetic recording bit.

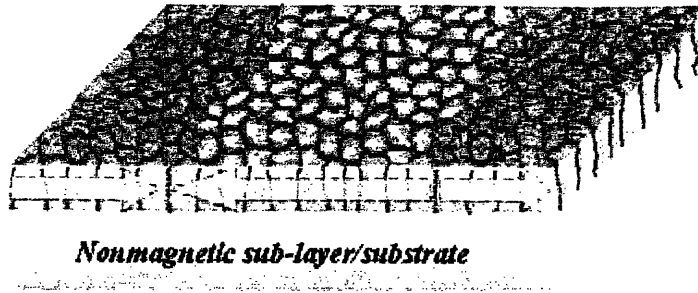

Figure 1-7 Schematic of in-plane magnetized bits in a polycrystalline thin film. The otherwise random magnetization in each magnetic domain is preferentially oriented by the recording field, resulting in a net magnetization of the recording bit.

Figure 1-5 shows a schematic of the basic structure of a read/write head used in longitudinal recording. The stray field from the gap introduces a flux inside the magnetic thin film. Such flux has to be large enough to be able to determine the magnetization state of the recording bit. It can be inferred that because of the decay of the field density with increasing distance from the gap, a short head-to-disk distance is essential.

Nowadays, longitudinally magnetized products having areal densities of around 70 Gb/in² have been marketed. Laboratory demonstrations have proven the feasibility of effectively storing information at nearly 170 Gb/in² [8]. A number of articles have been published over the last few years regarding the possibility of reaching what has become the benchmark of the magnetic recording industry: 1 Terabit per Square Inch recording density.

1.3 Perpendicular Magnetic Recording

Late in the 1970's, a new method of recording was proposed, in which the transitions separate regions magnetized perpendicularly to the films surface. This situation requires a magnetically uniaxial film in which a strong perpendicular anisotropy supports magnetization normal to the plane.

Today, the introduction of perpendicularly-magnetized media seems almost imminent. This new technology allows for higher areal densities because it uses a configuration in which the magnetic domains are oriented in such a way that the demagnetizing fields they exert upon each other are smaller. Figure 1-8 shows a comparison in the basic structures of perpendicular and longitudinal magnetic recording

technologies. Note that the perpendicular recording configuration decreases the magnetostatic energy in the bits.

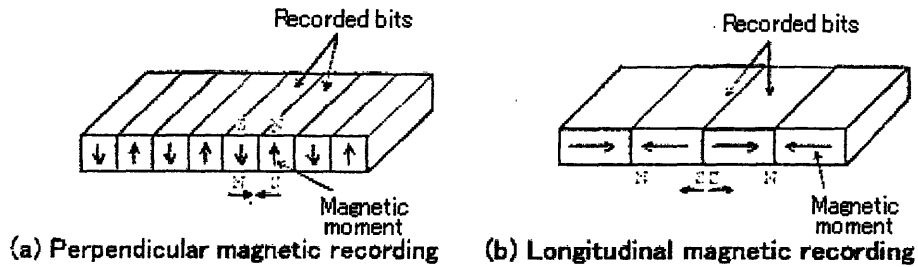

Figure 1-8 Comparison between the morphology of perpendicular (a) and longitudinal (b) magnetic recording systems.

Another advantage is that in perpendicular magnetic recording technology, the read and write fields are direct fields, rather than a fringe fields, which means a larger part of the field is used in the writing and reading processes. In fact the field that is effectively applied to the magnetic thin film is roughly twice as big when a single-pole head, which allows the use of materials with coercivities of up to 60% the saturation magnetization of the head, is used [9]. Having the storage bit lie inside the write gap also relaxes the condition of having to scale down the thickness of the film linearly with all the other dimensions. With larger thicknesses, the volume of the recording bits is not reduced as drastically as it would be using conventional longitudinal recording technology.

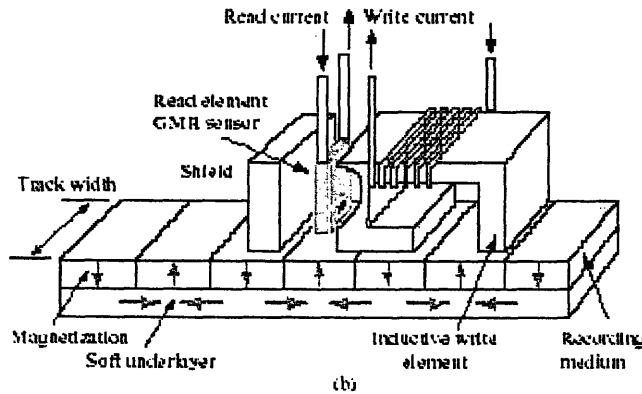

Figure 1-9 Schematic of a read/write magnetic recording head (for perpendicular recording). The field is applied by a single pole and travels through the magnetic layer and into its return path: the soft underlayer. The magneto-resistive element senses the transitions between adjacent bits of opposite magnetization state. [6]

Probably the most noteworthy advantage in perpendicularly magnetized media, when it comes to fabrication processes, is the ability to promote the growth of the magnetic layer in such a way that the preferred direction of magnetization lies directly perpendicular to the plane. This advantage comes from the nature of the fabrication methods that are used to produce the media. In longitudinal media, the growth of the storage layer can also be engineered, but the results that can be obtained are not as good. Even if can be assured that the preferred magnetization orientation lies within the plane of the disk, the easy axis of magnetization is free to take any orientation that is parallel to the plane (see Figure 1-7). This means that a larger number of grains is needed to form a magnetic bit, so that from statistical arguments the average magnetization of the magnetic region points in the desired direction.

Despite all its advantages, and the years of research spent on it (especially in Japan), perpendicular magnetic recording has not been launched into the market.

1.4 Areal Density: the 1 Tb/in² goal

In a very popular article, Roger Woods considered “The Feasibility of Magnetic Recording at 1 Terabit per Square Inch” [9]. In that article, physical and mathematical estimates were made to verify how realistic achieving that goal is for conventional magnetic recording technology, meaning one that performs recording on a uniform featureless medium. Fortunately for the industry, the results show no reason to believe this limit cannot be reached, at least not theoretically. As a matter of fact, historically the predictions for the limits to areal density in magnetic recording have been overcome every time. Figure 1-10 includes some of the predictions for the maximum achievable areal recording density that have been made during the history of HDD technology. S. H. Charap’s 40 Gbit/in² limit [10] was the last limit to be surpassed by current HDDs available in the market.

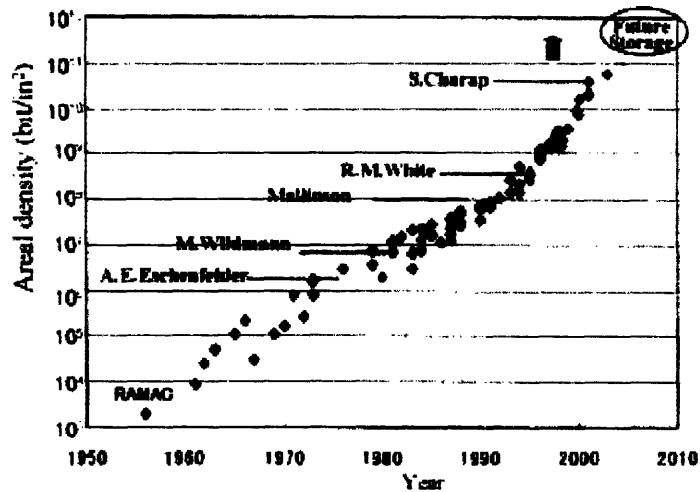

Figure 1-10 Progress of HDD and recording limit predictions. [11]

The magnetic recording industry has kept on pushing the limit back time after time, trying to improve the performance of their devices while making the smallest changes as they can to the basic design of HDDs. It can be said that the development of technology in the magnetic recording industry requires a balance between the need to introduce novel technologies to achieve greater areal densities and the natural reluctance from manufacturers to make significant changes in a proven successful design.

1.5 Current challenges in HDD technology

The continuous downscaling in magnetic recording devices has followed a basic trend: all the dimensions in HDDs have been reduced. This includes the magnetic domain size, the medium thickness, the head-to-disk spacing, the recording gap, the readback gap, the roughness of the magnetic medium and all the corresponding tolerances. As may be inferred from this information, the path hasn't been an easy one, and today the industry is concerned about the possibility of reaching a limit in the downscaling of the HDD technology [3], which would force the HDD manufacturers to take larger risk by attempting new and different technologies as substitutes for the current one.

Currently, conventional magnetic recording seems to be about to reach its limit. There are mainly three problems that have been considered as candidates to impede further reduction in the size of the features in the HDDs: Surface roughness, signal to noise ratio and the superparamagnetic limit.

1.5.1 Surface Roughness

As the fly-height of the recording heads in HDDs is reduced from its current value, around 10 nm, surface roughness can start playing a role as a limiting factor. In a very revealing simile, a Boeing 747 passenger airplane has been compared to a slider (the part of the HDD that includes the read/write head). As can be seen in Figure 1-7, if a slider was the size of a Boeing 747, the fly height would be only 1.5mm! It can be inferred that the restrictions this relative size imposes on the surface roughness of the media are very severe.

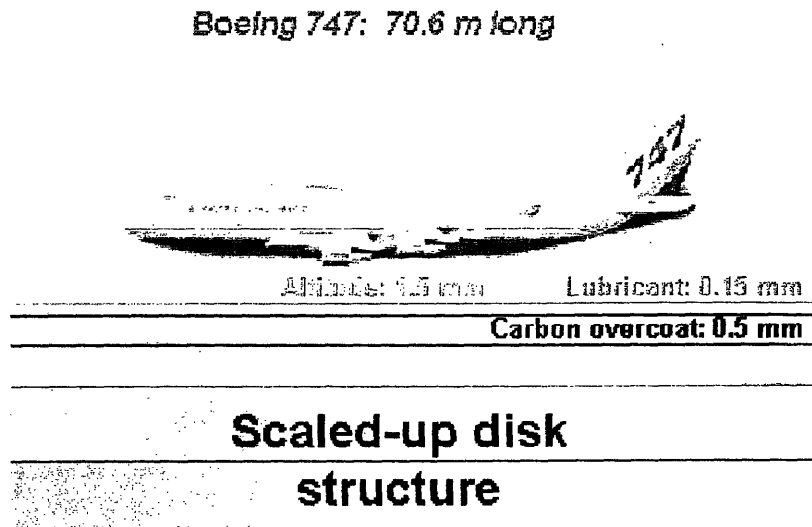

Figure 1-11 Up-scaled topology of a HDD. The relative size of the fly height and protective layers are compared to the size of a passenger airplane instead of the slider. The tolerances involved in the surface roughness of the media can be inferred to be of critical importance. [12]

Despite this very impressive comparison, it has been demonstrated that surface roughness is the last factor that could prevent the increase in areal density. Therefore, the other two problems are addressed in greater detail.

1.5.2 Signal to Noise Ratio (SNR)

After all the size reduction that has been carried out since the introduction of HDDs to the market, there has been a constant struggle to keep the SNR at an acceptable level. The challenge to having a low SNR is a natural consequence of granularity in polycrystalline films. As recording-bit size reduction is attempted, the areas in the boundaries of the recorded bits exhibit larger transition zones in which the net

magnetization is not resolvable. Figure 1-12 illustrates the need to reduce the grain size simultaneously with the magnetic bit size to preserve a high SNR.

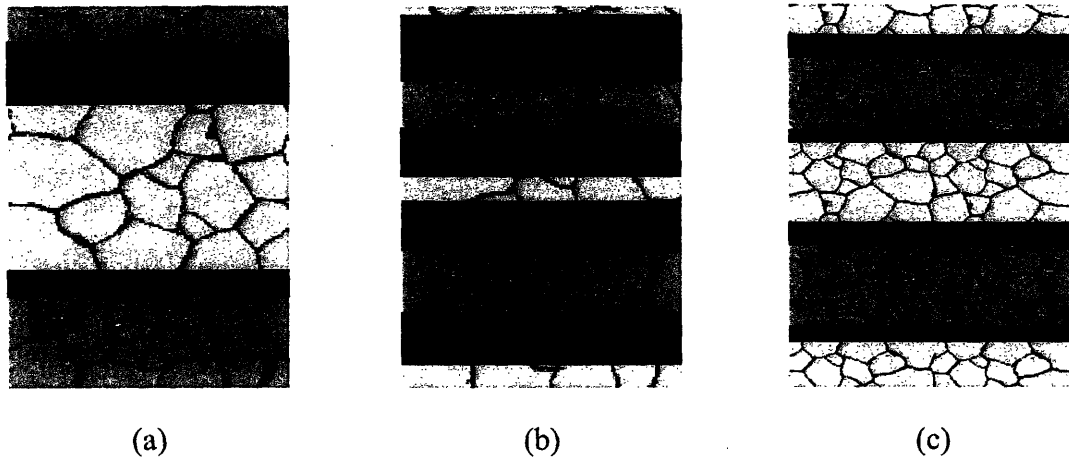

Figure 1-12 Effect of bit size reduction on signal to noise ratio. The red and blue zones represent opposite magnetization states. The shaded zones represent the noise. As the bit size is reduced from (a) to (b), the SNR decreases. (c) depicts the necessary reduction in grain size to preserve a high SNR.

Arithmetically, the SNR can be approximated, by grain counting arguments, to the number of grains per magnetic recording bit. Basically, $SNR \propto W_{bt} / V_g$ where W_{bt} : bit volume, and V_g : grain volume. Therefore, if in a HDD made of a continuous medium, making a magnetic recording bit consist of fewer grains is not an option if we want to keep the SNR high. The solution is straightforward: reducing the grain size can lead to an improvement in the areal density of the device. However, there is a problem with this reduction: The Superparamagnetic Limit.

1.5.3 The Superparamagnetic Limit

As time goes by, increasing the areal density of HDDs, while concurrently reducing the thickness of the recording media, could lead to a point at which the volume of each grain could become too small for it to have enough energy to keep its magnetization and therefore lose its capacity to store information. During the last 40 years, the HDDs features have shrunk by a factor of nearly 10^3 , which means the areal density has increased by 10^6 and the volume of a single particle has been reduced 10^9 times [1,4].

Magnetism theory dictates that the product of the first magnetic anisotropy constant, K_u , times the volume of a given particle, V , represents an energy barrier to

demagnetization and information loss. As can be seen from Equation 1-1 below, the expected time period for which we can assume a particle to keep its magnetization is related to the attempt frequency, f , and to the ratio between the energy barrier $K_u \cdot V$ and the thermal agitation $k \cdot T$ by:

$$t = f^{-1} \cdot e^{\left(\frac{-K_u V}{kT}\right)} \quad \Bigg| \quad \text{Equation 1-1}$$

That energy barrier can be overcome by normal thermal fluctuations in magnetization (defined by $k \cdot T$, where k is Boltzmann's constant and T is the absolute temperature). It is commonly accepted that the magnetic hardness, $K_u \cdot V$, has to be at least 40 times greater than $k \cdot T$. This assures the stability of the magnetic domain for a minimum period of 10 years at 300 K. Satisfying this criterion is the reason why the reduction in grain volume in magnetic media has to be accompanied by an increase in the magnetic anisotropy of the medium.

Having a large uniaxial anisotropy allows for smaller magnetic particles. Calculating the minimal radius of a stable particle is straightforward from the following equation:

$$r_o \approx \left(\frac{Ck_B T}{K_u}\right)^{1/3} \quad \Bigg| \quad \text{Equation 1-2}$$

It should be evident by examining Equation 1-2 that to achieve the small grain sizes that make possible the areal densities that are required in modern magnetic recording, a material with a large K_u is desirable.

Aside from helping reduce the minimum particle size, a material that shows a uniaxial anisotropy has, by definition, only one axis along which the magnetization prefers to align. The proper manipulation of this preferred direction is the reason why a thin film can be tuned to show out-of-plane magnetization.

A large value of uniaxial anisotropy is thus a valuable characteristic in a material that is intended to be used in high-density magnetic recording. However, a large K_u can also impede the magnetic writing process if it makes the "magnetic hardness" of the media too high.

1.5.4 Write Head Saturation

From Stoner-Wohlfarth theory of magnetic switching, it is known that increasing the anisotropy results in it becoming harder to write the data to the disk as the write field, H_w , increases as indicated by Equation 1-3, where M_s is the saturation magnetization of the media [13,14].

$$H_w \approx \frac{K_u}{M_s} \quad \Bigg| \quad \text{Equation 1-3}$$

It is also known that the highest write fields that are attainable in write heads, due to saturation in the material they are made of, are approximately 15 kOe [15]. Figure 13 shows the Slater-Pauling curve, which indicates a maximum saturation magnetization for an alloy of composition Fe₅₀₋₆₅-Co₅₀₋₃₅, equivalent to nearly 2.45 T.

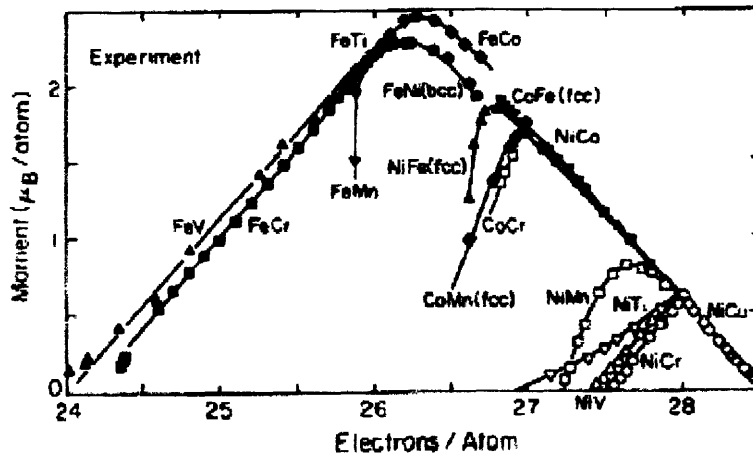

Figure 1-13. Slater-Pauling curve showing moment per atom (in Bohr magnetons) for metallic alloys as a function of valence electron concentration or alloy composition. [16]

Modern write poles are already made of materials with saturation magnetizations approaching the highest recorded values. As a matter of fact, real materials exhibit a saturation magnetization that tops out at approximately 2.5 T. Therefore, the prospects for developing materials and head structures to generate fields significantly greater than 25 kOe (2.5 T) appear slim [17].

1.6 The Magnetic Recording Trilemma

In summary, for high areal density data storage one would like a material with a large signal to noise ratio. A reduction in the grain size in polycrystalline films seems to solve this problem. However, a high uniaxial anisotropy material is needed to make the

magnetic bits thermally stable. High K_u can then make the material too hard to allow writing information on it. This chain of events is referred to as the magnetic recording “trilemma”. Figure 1-14 illustrates this so called trilemma.

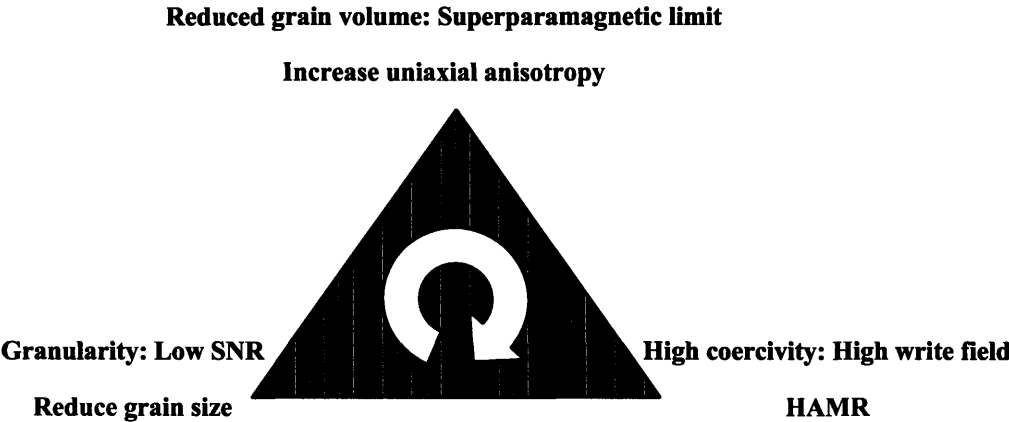

Figure 1-14: Magnetic recording “trilemma”. Low SNR can be improved by reducing the grain size. The resulting reduction in grain volume leads to the superparamagnetic particle regime. Increasing the uniaxial anisotropy can deal with this issue. However, a high coercivity is also produced in the media and to high a write field needed. Heat Assisted Magnetic Recording solves this last problem.

Heat assisted magnetic recording seems like a viable solution to this trilemma. The advantages, disadvantages, current achievements and challenges will be discussed in the following chapter.

References

- 1 D. WELLER and A. MOSER, *Thermal Effect Limits in Ultrahigh-Density Magnetic Recording*, IEEE Transactions on Magnetics, Vol. 35, No. 6 November 1999
- 2 C Denis MEE and Eric D. DANIEL, *Introduction to Magnetic Recording, the First 100 Years*, IEEE Press, 1999.
- 3 P. J. GRUNDY, *Thin film magnetic recording media*, Journal of Physics D: Applied Physics, 31 (1998) 2975-2990, United Kingdom 1998
- 4 D. A. THOMPSON, *The Future of Magnetic Data Storage*, Proceedings of the 5th International Symposium on Magnetic Materials, Processes, and Devices, The Electrochemical Society, Pennington NJ, 1999.
- 5 C. H. LAI, C. H. LAN and C. C. CHIANG, *Ion-irradiation-induced ordering of L10 FePt phase*, Applied Physics Letters, Vol. 83, No. 22, December 2003.
- 6 Y. WANG, Universität Bremen.
- 7 E. MURDOCK, Lake Arrowhead, Seagate Technology, 2003
- 8 K. SHIBATA, *FePt Magnetic Recording Media: Problems and Possibilities for practical use*, Materials Transactions, Vol. 44, No. 8, 2003.
- 9 R. WOOD, *The Feasibility of Magnetic Recording at 1 Terabit per Square Inch*, IEEE Transactions on Magnetics, Vol. 36, No. 1, January 2000.
- 10 S. H. CHARAP, P.-L. YU, Y. HE, *Thermal stability of recorded information at high densities*, IEEE Transactions on Magnetism, vol. 33, p978, 1997
- 11 J. P. WANG, *Magnetic Recording History* (Presentation), University of Minnesota.
- 12 D. WELLER, *Assault on Storage Density of 1 Terabit per Sq-inch and Beyond*, IEEE Magnetic Society Distinguished Lecture, 2004
- 13 A. MOSER, *Magnetic recording: advancing into the future*; Journal of Physics. D: Applied Physics, Vol. 35, 2002, p. R157-R167
- 14 T. RAUSCH et al., *Near Field Hybrid Recording with a Mode Index Waveguide Lens*, Optical Data Storage 2000 – Proceedings of SPIE; Vol. 4090, 2000, p 66.
- 15 H. F. HAMANN et al., *Thermally assisted recording beyond traditional limits*, Applied Physics Letters, 84, February 2004, p 810-812
- 16 R. C. O'HANDLEY, *Modern Magnetic Materials: Principles and Applications*, Wiley Interscience, 2000, p 144
- 17 R. WOOD, *Recording Technologies for Terabit per Square Inch Systems*, IEEE Transactions on Magnetics, Vol. 38, No. 4, July 2002

2 Heat Assisted Perpendicular Magnetic Recording (HAMR)

In order to solve the magnetic recording trilemma, there is a need to find a material with a large anisotropy that will keep information locked in place, but, at the same time, one that does not require a prohibitively large magnetic field to write. Even though this may sound paradoxical, HAMR is based on the satisfaction of both criteria, giving a magnetically hard material for storage purposes and rendering it magnetically soft during the writing period.

2.1 The principles of HAMR

One method of reducing media coercivity to a manageable level during recording is to temporarily and locally raise the temperature of the media. Both the anisotropy and the saturation magnetization of a material are temperature dependent, decreasing with increasing temperature. Fortunately, as Figure 2-1 shows, the coercivity has a stronger temperature dependence than the remanent magnetization. . As a matter of fact, the saturation magnetization is nearly constant (falling a $\sim 10\%/100^\circ\text{C}$) until just before the Curie temperature. This fact is exploited in HAMR so that large anisotropy materials can be used as the magnetic recording medium.

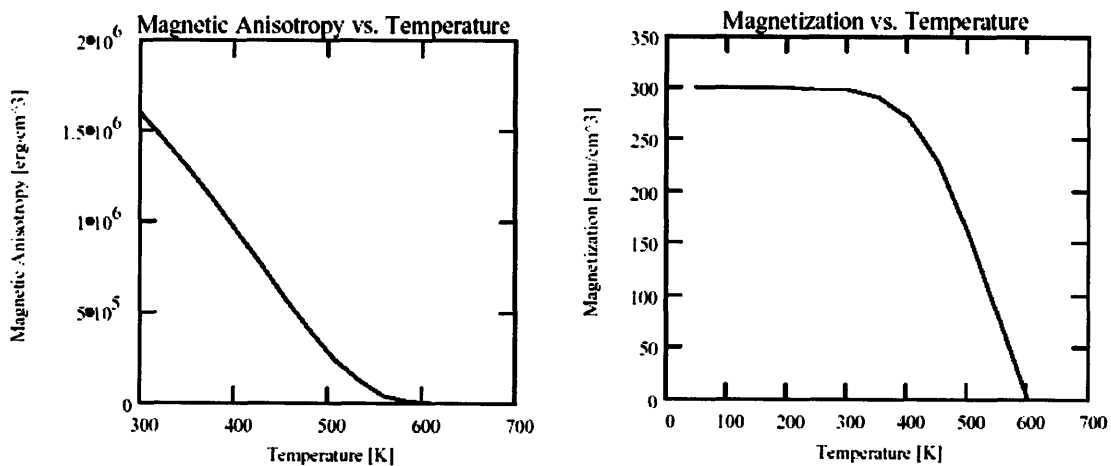

Figure 2-1 Schematic of temperature dependence of coercivity and remanent magnetization in a typical magnetic recording medium. Coercivity drops towards zero on approaching the Curie temperature, T_c , faster than does the magnetization. [1]

Equation 1-3 indicates that the anisotropy can be close to a value of zero before the medium loses long range ordering at the Curie temperature, T_c .

In HAMR the bit is irradiated by a focused laser beam that raises the local temperature of the film and lowers the anisotropy of the hard magnetic material. While in the magnetically soft state, H_w , is low enough that data can be written. Once written, an under-layer of heat sink material in the thin film conducts the heat away, thereby reducing the temperature and increasing the anisotropy.

Bit densities for longitudinal media are expected to approach the 150 Gbit/in² range [2] and this is expected to rise another 2-5x with perpendicular media [3]. Theoretical calculations of the areal bit densities for perpendicular media with HAMR indicate that recording densities well above 1Tbit/in² are possible with the appropriate technological advancements.

2.2 Current research: Heating

HAMR is a very promising technology but is still a few years away from becoming a practical technology used in industry. At the moment, it is interesting to focus on the current obstacles to the adoption of HAMR and to review the research into those areas. The most obvious of these obstacles is in the method of heat delivery to the media at such small scales. HAMR is the basis of magneto-optic (MO) recording, a technology that has been developed as a storage alternative to HDDs. In MO recording a laser beam focused to a spot (close to 1 μm in size) heats up the medium close to its Curie temperature so that a small external magnetic write field can record data onto the medium. Even though MO is a mature technology that already exists in the market (for instance in DVD technology), the challenges that HAMR faces as an alternative to conventional HDD technology are associated with the much smaller size of the region to be heated. The challenges associated with this are not easy to overcome and are not simply based on the downscaling of the magneto-optic-based devices [4].

Locally heating the material in the area to be written without affecting the neighboring bits can be a difficult problem when bits have nanometer dimensions. In order to obtain a substantial increase in storage density with HAMR, the temperature rise in the medium during recording must cause a large decrease in coercivity. Realistically a temperature rise of at least 200 °C will be required [4].

It has been demonstrated that making a head that incorporates heating and writing sources is possible [5]. Different setups have been tried, but most of them consist of a heat source that is mounted on the leading edge of the recording head. This arrangement causes a lag time between the heating of the media and the application of the writing field. A few novel techniques have been developed for HAMR purposes, most of which employ laser light to supply the energy needed for heating.

2.2.1 Light generation techniques

Delivering light to the slider is one basic issue. There are two approaches to this problem. The first one considers the *in situ* generation of light, placing a semiconductor laser directly on the slider, while the second one proposes the light delivery by an optical fiber running from an off-board laser to the slider.

Even though a light generation method will be essential in the development of a HAMR system, the technology to produce it seems to be well known nowadays. The reduced dimensions of the features in an ultrahigh areal density HDD do not impose such severe restrictions to the production of light as they do to the means by which the light is delivered to the disk surface. More attention is then paid to this second set of techniques in the next section.

2.2.2 Light delivery techniques

In magneto-optical drives, thermomagnetic recording is performed on a length (and hence areal density) scale commensurate with the classical diffraction limit of the heat source that heats the recording medium: visible light.

For storage densities on the order of 1 terabit per square inch, the required bit size needs to be less than 50 nm. It is obvious then that employing diode laser sources and conventional optics is not possible because their resolution is limited by the diffraction limit. Equation 2-1 describes the minimum resolvable feature size that can be achieved by forcing light through a gap on a screen, as a function of the size of the gap, g , and the wavelength of the light source, λ .

$Minimum_resolvable_feature = (g \cdot \lambda)^{1/2}$	Equation 2-1
--	---------------------

Using a 436 nm light source and a gap of 50 nm, the minimum spot size can be calculated to be 147nm in its shortest dimension. Sub-diffraction limit techniques must then be employed, and have been studied in several publications [6].

2.2.2.1 The solid immersion lens

Maybe the most obvious way to produce a well defined spot with a light source is to use a focusing lens. The focused spot size from a lens is proportional to the wavelength of the light, λ , and inversely proportional to the numerical aperture of the lens, NA , which is given by $NA = n \cdot \sin \alpha$, where n is the refraction index of the lens material and α is the angle that the beam forms as it is concentrated on the surface of the medium. Obviously, it is not possible to tune the wavelength of the light sources, and there is a limit for the minimum wavelength that is available from light emitting devices. The best option is then to modify the numerical aperture of the lens. One way to do that is to increase the index of refraction of the medium in which the lens is brought to focus, so to increase the NA and accordingly reduce the spot size.

The theoretical full width at half maximum (FWHM) spot diameter for a solid immersion lens (SIL) is given by Equation 2-2, in which n is the refraction index of the lens material.

$$d_{\min} = \frac{0.51 \cdot \lambda}{n} \qquad \text{Equation 2-2}$$

It is worth noticing that Equation 2-2 predicts spot sizes that can be smaller than the light source that is used. Unfortunately, only apparently does this fact give a great advantage. Figure 2-2 compares the FWHM spot diameter vs. the wavelength of the source light for different materials. It can be seen immediately that even at the smallest FWHM values, the spot size is too big for an ultrahigh areal density system. To make things worse, the spot sizes predicted by Equation 2-2 are never realized in practice because the angle of incident light is limited by the NA of the objective lens.

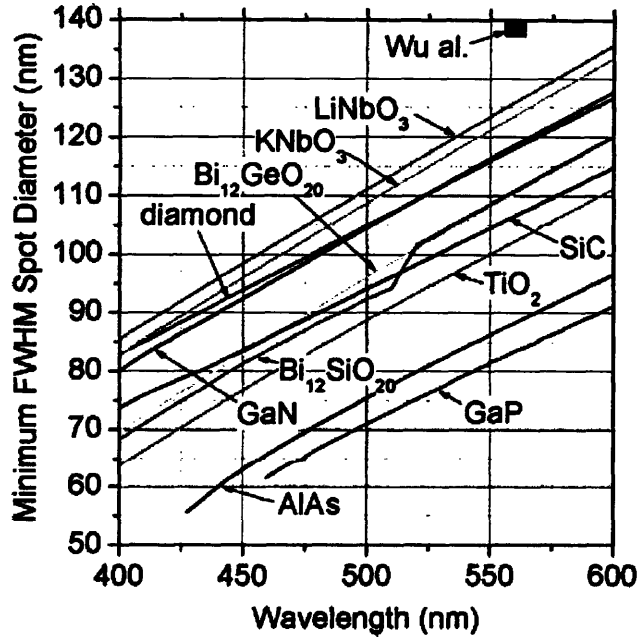

Figure 2-2. Minimum full width at half maximum spot diameter vs. source light wavelength for different SIL materials. Note the minimum achievable spot size is ~55nm. [4]

2.2.2.2 Subwavelength apertures

By placing a screen in front of a beam of light, it is possible to reduce the size of the projected spot. However, as it might be inferred, the power that reaches the target is too small when compared to the power that needs to arrive at the screen. Equation 2-3 models the transmittance, defined as the ratio between the incident energy and the energy that makes it through, for a hole of diameter d on a screen.

$$T = \left(\frac{64\pi^2}{27} \right) \cdot \left(\frac{d}{\lambda} \right)^4 \quad \text{Equation 2-3}$$

To have a sense of how much energy is lost on the screen, for a 50nm circular hole, using a 400nm light source, the transmittance would be of only 0.6%. However, Equation 2-3 is valid only for ideal conductors. In real conductors the skin depth can play a role if the screen's thickness is comparable to the aperture size, making the real transmittance a lot larger than Equation 2-3 predicts. In fact, the transmittance for the same 50nm hole considered above, this time on a 50 nm thin film silver screen would be close to 40%. This result is caused by the presence of surface plasmons (SP), a collective oscillation of surface charge that does not exist in ideal conductors. It is interesting to point out that the transmittance of a single aperture, calculated as the power per unit area

that meets the target over the power per unit area that reaches the hole can be greater than unity because of SPs.

Even though SPs can accomplish a higher transmittance, the spot sizes that can be achieved are larger than the physical apertures on the screens due to skin depth effects. In addition to that, the presence of a narrowly defined target in the vicinity of the aperture can also reduce the peak intensity delivered to a small bit.

Bragg scattering of light is believed to excite SPs, but other excitation techniques (Kertschman [7] and Otto [8]) can achieve the same purpose when applied through a glass prism onto an appropriately designed thin film stack.

Figure 2-3(b) shows the shape of various apertures that have been ion-milled into the gold thin film of the stack (Figure 2-3(a)). The high resolution focusing results are similar for all structures and transmittances of up to 5 times the incident energy density have been achieved [4].

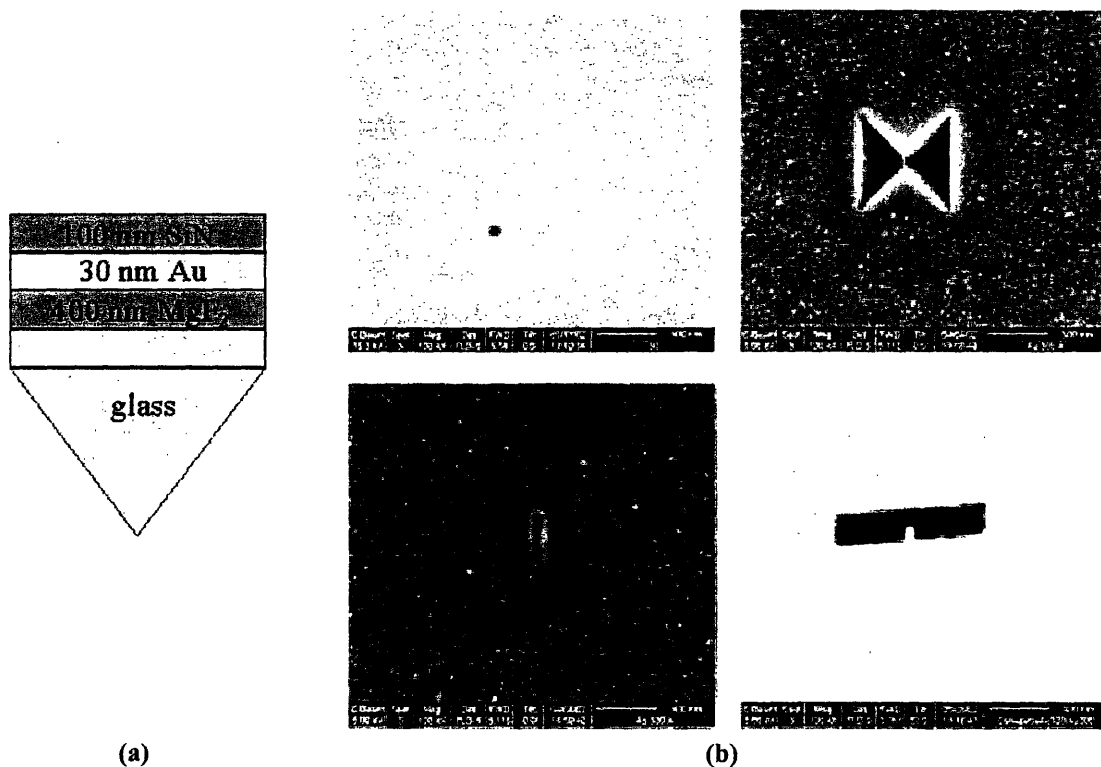

Figure 2-3. (a) thin film structure to induce surface plasmons by applying light onto the prism. (b) Ion-milled apertures on the gold layer. Clockwise from the top left: 50nm diameter hole, 50nm gap bow tie slot antenna, 50x50nm gap C shape aperture, and 50x350nm rectangular slot. [4,6]

2.2.2.3 Tapered and metallized optical fibers

The use of this sort of devices has proven to be ineffective. The throughputs obtained in these fibers are as low as 10^{-6} . For fibers narrower than cut-off, given by $0.6 \cdot \lambda / n$, the light decays exponentially with distance, instead of propagating.

Because the light throughput of a tapered fiber is so small, these devices are not attractive for commercial applications, even though lab demonstrations have used them successfully for recording purposes [9].

2.2.2.4 Pyramidal probes

When a pyramidal silicon probe (similar to the ones used in atomic force microscopy, as seen in Figure 2-4) with an aperture at the tip was tested as a light delivery method, the results revealed the light throughput is on the order of 10^{-4} [10]. Again this efficiency is too low to be considered for commercial applications.

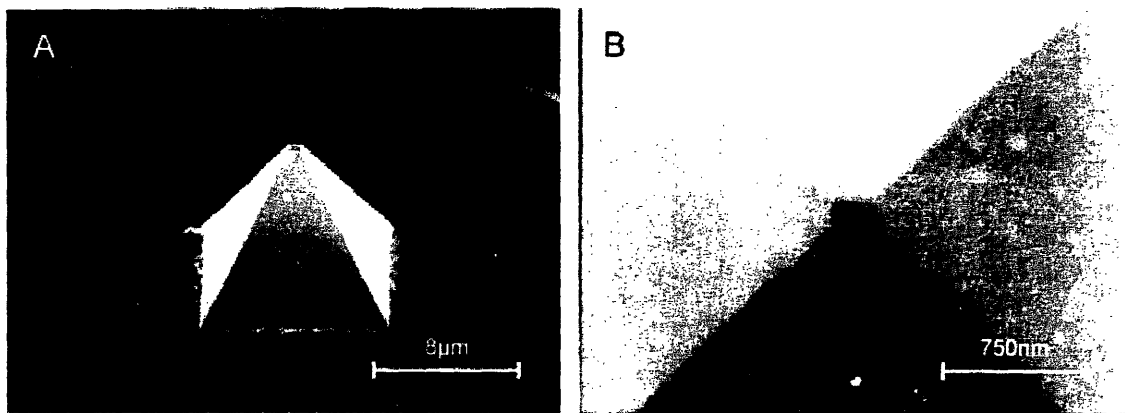

Figure 2-4 Pyramidal Si probes fabricated using AFM-tip technology. Note the $\sim 100\text{nm}$ flat spot at the tip of the structures. [11]

On a variation of this method, two of the side walls of the pyramidal structure were covered with a gold thin film, making a sort of bow-tie antenna at the tip. The transmittance in this case was found to be very close to unity, and the FWHM spot diameter was roughly 13 nm [11].

2.2.2.5 Resonant cavities

Microwave cavities can have the capacity of emitting light if excited. Placing a bow-tie structure as a screen for the light coming from the cavity has proven to have efficiencies of up to 30%. The spot size has been found to be approximately of the same size as the aperture on the bow-tie structure. However, since the properties of such

cavities vary a lot from microwave to visible light frequencies, the results are expected to differ from the ones presented above, having larger spot sizes due to skin depth effects on the thin film that supports the bow tie antenna.

2.2.2.6 Waveguides

Coaxial waveguides have the ability of confining light and directing it to an area that is related to the diameter of the center conductor. Even though such an internal conductor can be made to be arbitrarily small in diameter, the smaller it gets the more damping that is associated with the waveguide and the larger the spot size gets when compared to the diameter of the conductor. A core radius of ~ 10 nm is necessary to produce a spot size of 50 nm.

The propagation distance in a small diameter waveguide is only 800 nm, which makes waveguides not useful when transporting light over longer distances. This is why waveguides are not considered as a way of transporting light from an off-board laser to the slider, but rather a method of directing the light once on the recording head.

Magnetic recording heads including waveguides have been tested at the lab scale. Lab demonstrations have so far demonstrated recording densities of up to 70 Gbit/in², but the authors speculate that by using high refractive index materials the heated zone size can be reduced and bit sizes of 60 nm x 25 nm are possible. This corresponds to an areal density of 500 Gbit/in². [2]

Planar waveguides are capable of confining light beams on the perpendicular direction (their shortest dimension), however, light confinement becomes a problem in the direction parallel to the plane of the waveguide. Nevertheless, it is believed that a mode index lens can reduce the spot size in the direction of the plane to about a wavelength without much energy loss, although a wavelength might be too large a dimension for the width of a bit in an ultrahigh areal density recording system [4].

2.2.3 Other heating methods

Other methods that do not necessarily depend on the delivery of light to the surface of the media have also been studied. In one of these systems, thermal energy is emitted by a cantilever Si AFM tip, which is heated by pulses from a laser diode (~ 70 mW) focused on the back of the cantilever structure. The tip is positioned close to the magnetic

media such that some of the incident energy is transferred, via the AFM tip, to the film which then reaches a temperature close to 500°C.

By precisely controlling the incident power on the cantilever, it is possible to achieve bit sizes of ~50 nm (as measured on a MFM). However, because the resolution of the AFM is not high enough to accurately measure the exact size of the bit, it is believed that the real bit size could be somewhat smaller (~30 nm) allowing for the lab demonstration of magnetic patterns that correspond to 400 Gbit/in² [2].

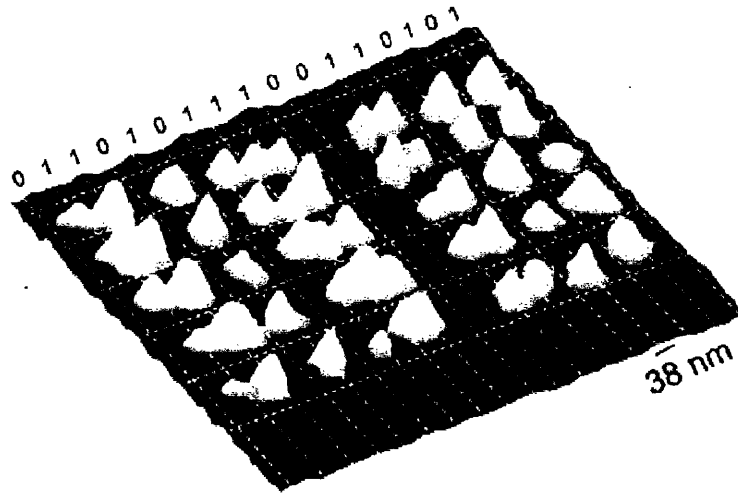

Figure 2-5. Bits recorded using an AFM tip as heating device. Bit density corresponds to 400 Gbit/in². [2]

2.2.4 Heat management and durability

The temperature of the transducer must also be considered, knowing that the efficiency in all the abovementioned devices is very low and most of the energy that goes into them will end up heating the device. The working temperature of the device depends on the amount of power that does not leave the transducer and on how efficiently it is removed from it.

As might be observed from section 2.2.1, almost all the devices that have been studied involve metallic parts, specifically gold and silver are common. The magnetic part of the recording head is also metallic. All these metallic parts and their inherently good thermal conductivities, can help to successfully dissipate the heat in the slider.

One can assume the physical integrity of the recording head will not be jeopardized by thermal effects, taking into consideration that the melting temperatures for all these metallic components are well above the Curie temperature of the magnetic recording

media, which will probably be the highest temperature achieved in the whole system. The durability of the transducer is then believed not to be endangered from this perspective.

However, the durability in a system with parts moving at 40 m/s at only a few nanometers from each other can naturally be questioned. Moreover, highly conductive metals like Au and Ag are mechanically soft. For this reason, surface roughness plays such a critical role in the design of future HDDs [4].

2.2.5 Alternative heating configurations

It is important to point out that not having a heating method that delivers a spot size that is exactly the size of a bit in a terabit per square inch system does not imply the failure of the system as a whole. According to the principles of HAMR, two elements are needed to perform a writing process on the media: a write field and a heated spot. Experiments have been made in which the size of the heated spot and the size of the write head do not correspond. It has been demonstrated that it is possible to heat up an area that is significantly larger than the size of the head, then apply a write field in only a small part of the magnetically softened area, thus creating a bit that is determined by the dimension of the write head. This is especially interesting because the ability to focus the heating beam on a small enough, nanometer-size area is still not fully developed. See Figure 2-6 (a).

The opposite idea, heating up a spot that could be smaller than the magnetic head, and therefore magnetically-softening only a part of the film that lies directly in the write gap, has also been considered. In such configuration the need to reduce the write head would be less critical. Unfortunately, there would be a need to have a very well localized beam to heat up a bit-size spot. See Figure 2-6 (b).

An alternative to this second method would be to rely on the thermal properties of the media and the substrate. The disk surface would have to disperse the heat in such a way that by the time the magnetic field was applied by the write head, the heated spot had contracted to a size that is appropriate for an ultrahigh density storage system. From a scaling perspective, this allows for the track width to decrease without a need for further reductions in head size and current technologies can continue to be used for manufacture of the write head. See Figure 2-6 (c).

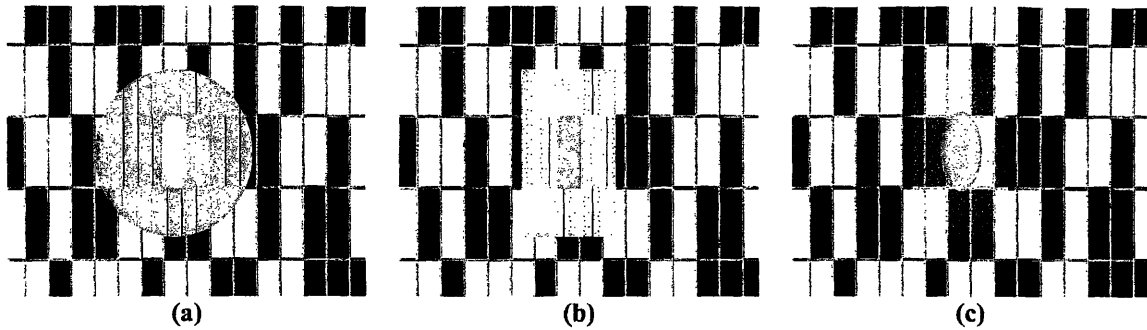

Figure 2-6. Three possible configurations to achieve small size bits without having bit-size magnetic (green) and thermal (red) fields. (a) large thermal field and small magnetic field, (b) small thermal field and large magnetic field, (c) large thermal field contracted by conduction and large magnetic field.

Recording heads are still being developed, and important advances are often reported in the industry. Nonetheless, the design and optimization of the heads is only one of the challenges that HAMR needs to overcome to make it into the marketplace. Other important concern about the development of HAMR is the materials that will be used as recording media.

2.3 Current research: Media

An ideal material for HAMR must satisfy several criteria. The magnetic properties are one fundamental requirement. Obviously, some of the same properties desired in perpendicular media are also important in HAMR, such as high values of uniaxial anisotropy, coercivity, magnetization, and environmental stability/corrosion resistance. However, other characteristics, such as thermal conductivity, surface hardness, ease of fabrication, etc. will play a defining role when the magnetic recording industry needs to reach a decision regarding the preferred material.

Several candidate alloys are available that offer both small grains as well as sufficiently high anisotropy [12]. In particular the $L1_0$ phases of some tetragonal intermetallic compounds have grain sizes on the order of 3-5 nm (one third to one half that of conventional media used at present time) while exhibiting anisotropy values that are more than 20 times higher than that of present day media [13]. Table 2-1 shows a comparison for the magnetic properties of different recording media.

Table 2-1. Magnetic properties of hard magnetic alloys for ultrahigh density recording. From Weller et al. [12]. All materials can support stable particles smaller than or comparable to 10nm for a storage time of 10 years. K_u : uniaxial anisotropy, M_s : saturation magnetization, $K_u = 2 H_K / M_s$; anisotropy energy density, where H_K is the anisotropy field; T_C : Curie temperature, D_C : single domain particle size, D_P : minimal stable grain size.

	Material	K_u (10^6J/m^3)	M_s (emu/cm ³)	H_K (kOe)	T_C (K)	D_C (μm)	D_P (nm)
	CoPtCr	0.2	298	13.7	-	890	10.4
Co-Alloys	Co	0.45	1400	6.4	1404	60	8
	Co ₃ Pt	2	1100	36	-	210	4.8
L ₁₀ phases	FePd	1.8	1100	33	760	200	5
	FePt	6.6-10	1140	116	750	340	3.3-2.8
	CoPt	4.9	80	123	840	610	3.6
	MnAl	1.7	560	69	650	710	5.1
Rare-earth	Fe ₁₄ Nd ₂ B	4.6	1270	73	585	230	3.7
trans. metals	SmCo ₅	11-20	910	240-400	1000	710-960	2.7-2.2

2.3.1.1 Co alloys

Cobalt is the quintessential magnetic material when it comes to magnetic recording. Co-X multilayer films have been studied extensively for perpendicular recording; they are a good initial set of materials to consider for modification and use in a HAMR media. HCP Co naturally shows uniaxial anisotropy. Grain-to-grain magnetic coupling can be avoided by tuning the composition and fabrication processes of Co-based thin films.

In ternary alloys, one of the elements usually segregates to the grain boundaries, making the magnetic coupling between grains weaken. Oxide formation at grain boundaries is also believed to play a role in the magnetic decoupling of the grains in these films. Regardless of which or both play a factor, the magnetic grains are substantially decoupled from one another. The CoPd films also show good reduction in H_C and M_s at elevated temperatures as evident from Figure 2-7.

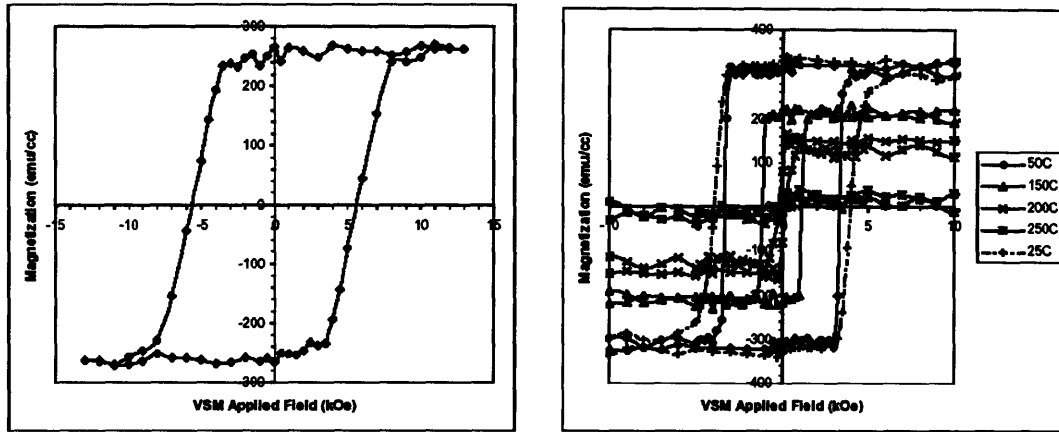

Figure 2-7: VSM hysteresis loops for Co-Pd film. Sample on the left was exposed to air at 250-300°C for 15 min. On the right is a series of measurements at different temperatures [1].

It can be seen that these changes in M_s and H_c with heating are reversible upon cooling (Figure 2-8), a property that is required for HAMR. Overall, data presented suggest that a Co-Pd thin film is a suitable candidate for HAMR.

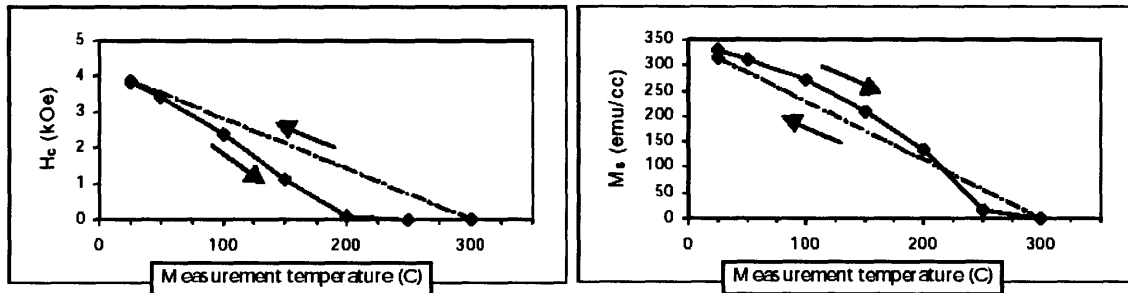

Figure 2-8: Reversibility in write field, H_c , and saturation magnetization, M_s , with temperature. CoPt thin film. [1]

The L_{10} phase of CoPt films have been reported to have coercivities over 10 kOe when doped with ZrO_x [14]. Other CoPt films show nanosized stable particles when doped with Ag or C.

2.3.1.2 FePt media

From Table 2-1 it is evident that FePt has excellent magnetic properties, especially when it comes to the uniaxial magnetic anisotropy constant. It is also important to notice the superparamagnetic particle size, D_p , calculated according to the industry standards, which requires at least 10 years of memory stability. FePt offers a very small thermally-stable particle size. In fact, some promising projections have been made regarding this

size. If a medium could be produced with little exchange energy between particles and excellent particle-size-distribution control, areal densities of up to 25-50 Tbit/in² could be achieved [15]. Another fact to notice is the Curie temperature of the FePt system which is relatively low. For all these reasons FePt has been the subject of research for many publications.

A variety of deposition and postdeposition methods have been the subject of ongoing research, showing the great interest that exists in the scientific community regarding the FePt system for perpendicular magnetic recording.

Molecular beam epitaxy has proven to be successful in achieving good magnetic properties in the films; however, the need for high deposition temperatures and long processing times makes this method not suitable for magnetic recording media applications, due to the promotion of grain growth.

The need for low deposition temperatures has led to a variety of sputter-deposition methods amongst which the ones that do not require a heated substrate are preferred in order to avoid grain growth and grain-to-grain magnetic exchange mechanisms.

Thermal annealing, although useful in obtaining the best magnetic properties, promotes grain growth, which can be a concern when trying to get nano-sized particles. On the other hand, ion-irradiation in large, high-energy doses can promote the formation of the high anisotropy phase even at low temperatures, which do not increase the grain size significantly.

Multilayered thin FePt films have been shown to be effective in reducing the ordering temperature of the high magnetic anisotropy phase, especially those consisting of mono-atomic or near-monoatomic layers of Fe and Pt. The addition of non-magnetic inclusions is an effective way of inhibiting grain growth and intergranular magnetic exchange. Figure 2-9 shows the effect of the inclusion of C in a FePt thin film. Different C concentrations are shown; the mean particle size drops from ~20 nm with no C to 5 nm with 25% C. 4 nm particles are attainable when using 50% C.

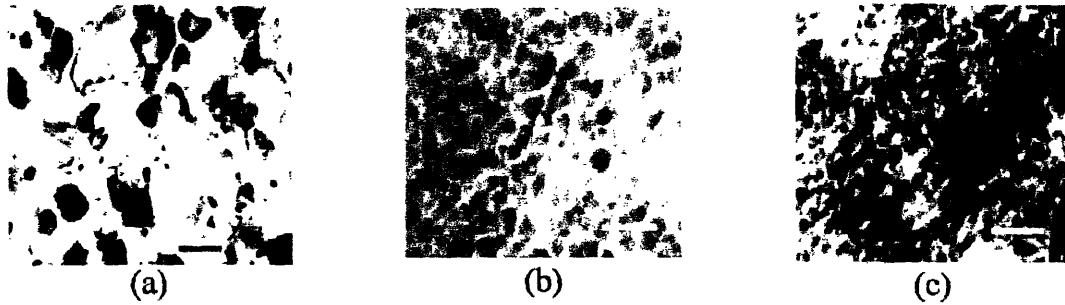

Figure 2-9: Transmission electron micrographs of the $(\text{FePt})_{1-x}\text{C}_x$ system prepared at $400\text{ }^\circ\text{C}$ substrate temperature with C doping of (a) 0%, (b) 25%, and (c) 50% and their grain size distributions. The horizontal bar in the TEM picture scales of 20 nm. [16]

4 nm particles, however, are not useful for perpendicular recording since they present in-plane magnetization. On the other hand, 5 nm particles do show out-of-plane magnetization. This last type of particles is so far the most suitable to be used in a 1 Tb/in^2 system [16].

2.3.1.3 Other systems

Other than the FeX and CoX systems, numerous other materials systems have been tried such as CoCrPt [5], TbFe and Co/Pt on mica [2], and TbFeCo [17]. Other rare-earth-based materials are known for being magnetically hard. However, most of them are also chemically very reactive and are thus avoided in an application such as this, in which thin films must coexist with several other layers at elevated temperatures.

A great amount of research is currently done on recording media. The leading companies in HDD production pay considerable attention to these future technologies and so do the universities worldwide. Nevertheless, the design of the recording head and the selection of the medium have to be done concurrently. It is thus not possible to identify a leading material system yet.

2.4 Heat dissipation

Other interesting materials problems arise from the engineering of a heat sink underlayer. While most perpendicular media require a soft magnetic underlayer to provide a magnetic path back to the write head, a HAMR does not necessarily require it because the write fields do not need to be as high as in conventional recording. For efficiency of the write head, a soft underlayer is desirable; however, this underlayer should primarily act as a heat sink.

The speed at which bits can be recorded, and to a lesser extent their stability, are defined by the cooling rate of the media and its thermal response time. Depending on the method of heat delivery, the optical reflectance and absorbance of the material may also need to be considered to maximize device efficiency. The stability of the media at room temperature may also allow for the omission of the soft underlayer that is required in standard perpendicular media to reduce demagnetizing fields [1].

High bit densities inherently require high rates of recording for them to be useful. A high-density disk that takes a long time to record information to is not very useful. To achieve a high record rate and data retention rate, the limiting factor that will likely need to be overcome is the removal of heat from the newly recorded bit. The media must cool down sufficiently rapidly after writing so that the residual heat does not render the just-written information thermally unstable [13]. To achieve recording data rates of 500 MHz or higher, the thermal response time must be less than 1 ns. This response time is possible using aggressive heat sinking of the recording medium, but this requires additional optical power to be delivered [4].

To overcome the heat dissipation challenge, Al layers have been used beneath the data layers as a thermal conduction layer with significant success [18]. It was found that by inclusion of an Al underlayer it is possible to write smaller bits (successfully at ~100 nm) compared to 200 nm without the heat sink substrate (see Figure 2-10).

	Disk A (Slow Cooling)	Disk B (Rapid Cooling)
800 nm		
400 nm		
200 nm		
100 nm		

Figure 2-10: The effect of heat sink layer on the magnetic domain patterns at different bit size scales. Disk A has no heat sink layer while Disk B has an Al underlayer [18]

Although, the inclusion of a specific heat-sink layer is not the norm it will likely be that an underlayer will be required that is capable of rapid conduction of the heat away from the memory layers to insure retention of the magnetic structure.

2.5 Summary

Conventional magnetic recording will soon reach its limits. Perpendicular magnetic recording is considered the method that can provide further increase in the areal density of HDDs. The introduction of perpendicular magnetic recording is expected to occur sometime in the next couple of years. That technology can probably increase recording density by a factor of 2 or 3. However, a limit to this technology has already been identified. The high write fields that are required to write on high anisotropy media might soon be too high for the recording heads to produce.

Heat-assisted magnetic recording can be incorporated into perpendicularly magnetized storage devices to extend the roadmap of HDD technology beyond the 1 Tbit/in² milestone. Recording densities of up to 50 Tbits/in² have already been predicted if an effective combination of recording head and medium is found.

The main barrier towards the development of magnetic recording media is in the heating of the media over a small area and achieving high heat-dissipation rates. Many techniques have been developed to deliver thermal energy to the film, although all have drawbacks that still require further research.

The second major hurdle is in materials selection and design. Magnetic recording layers that exhibit high-magnetic-anisotropy must be engineered keeping in mind that consistently small grains are key for the production of a high recording density medium.

Besides a high magnetic anisotropy material, a material that offers high thermal conductivity and a system that offers good energy dissipation properties must be found. In order to preserve the recorded domain pattern, the bits must be rapidly cooled or writing on adjacent bits can demagnetize the surrounding data. This requires the development of heat sink layers such as Al or layers that can be used as a heat sink and double as a soft flux closure path. The other major materials problem is in the magnetic recording layers themselves as unique properties are required in HAMR that are not necessary in traditional thin-film media.

It is believed that a 10-fold hypothetical density gains can be achieved with HAMR. These huge densities could extend the life of HDD, using moderate changes on their structure, for at least 10 years. However, the challenges in the development of such systems are equally huge [12].

References

- 1 C.F. BRUCKER and T.W. MCDANIEL, *Materials Development for Thermally-Assisted Magnetic Recording Media*, Materials Research Society Symposium Proceedings, Vol. 674, 2001
- 2 H. F. HAMANN et al., *Thermally assisted recording beyond traditional limits*, Applied Physics Letters, 84, February 2004, p 810-812
- 3 H. N. BERTRAM and M. WILLIAMS, *SNR and Density Limit Estimates: A Comparison of Longitudinal and Perpendicular Recording*, IEEE Transactions on Magnetics, Vol. 36, No. 1, January 2000
- 4 W. A. CHALLENGER et al., *Light Delivery Techniques for Heat Assisted Magnetic Recording*, Japan Journal of Applied Physics, Vol. 42, pp 981-988, 2003
- 5 T. RAUSCH et al., *Near Field Hybrid Recording with a Mode Index Waveguide Lens*, Optical Data Storage 2000 – Proceedings of SPIE; Vol. 4090, 2000, p 66.
- 6 T. W. MCDANIEL et al., *Issues in Heat-Assisted Perpendicular Recording*, IEEE Transactions on Magnetics, Vol. 39, No. 4, July 2003, p. 1972-1979
- 7 E. KRETSCHMAN, *Z. Physics*, 227, 1969, p. 412
- 8 A. OTTO, *Z. Physics*, 216, 1968, p. 398
- 9 E. BETZIG et al., *Near-field magneto-optics and high density data storage*, Applied Physics Letters, Vol. 61, 1992, 142
- 10 C. MIHALCEA et al., *Multipurpose sensor tips for scanning near-field microscopy*, Applied Physics Letters, 68, 3531, 1996.
- 11 B. J. KIM et al., *Molded photoplastic probes for near-field optical applications*, Journal of Microscopy, 202, 2001, p 16-21
- 12 D. WELLER, A. MOSER et al., *High Ku Materials Approach to 100 Gbit/in²*, IEEE transactions on Magnetics, Vol. 36, No. 1 January 2000
- 13 M. ALEX et al., *Characteristics of Thermally Assisted Magnetic Recording*, IEEE Transactions on Magnetics, Vol. 37, No. 4, July 2001
- 14 K.R. COFFEY et al., *High anisotropy L10 thin films for longitudinal recording*, IEEE Transactions on Magnetics, Vol. 31, 1995, p. 2737
- 15 D. WELLER, *Future Magnetic Recording Media*, unpublished article, Seagate Technology, Pittsburgh PA, 2003.
- 16 H. S. YO et al., *Fine control of L10 ordering and grain growth kinetics by C doping in FePt films*, Applied Physics Letters, Vol. 82, No. 14, 2003.
- 17 J. J. M. RUIGROK et al., *Disk recording beyond 100Gb/in²: Hybrid Recording?*, J. Appl. Phys. 87 (2000)
- 18 H. SUKEDA et al., *Thermally assisted magnetic recording on flux-detectable RE-TM Media*, IEEE Transactions on Magnetics; Vol. 37, No. 4, July 2001, p1234-1238.

3 Intellectual Property Analysis

As with any other technology, the intellectual property (IP) regarding HAMR is a valuable asset for the companies that develop it. It has been said that the magnetic recording industry sees HAMR as the next step in the natural evolution of the devices they produce. The companies that are currently involved with the production of HDDs should be concerned with creating a product that incorporates perpendicular recording technology.

In an industry such as the magnetic recording industry, that has a long history of developments, there is a very well established trend that demands the constant improvement in the technologies that make it to the marketplace. The roadmap of HDD technology demands the introduction of a new technology in the near future to solve the problems related to the superparamagnetic limit. Therefore, in two year's time we could begin to see the introduction of systems that incorporate perpendicular magnetic recording. Heat assisted magnetic recording, either longitudinal or perpendicular, will need a longer time to be introduced.

Further along the HDDs roadmap, the technology faces another challenge, namely the high writing field needed to record information in high anisotropy materials. This problem can be solved by HAMR.

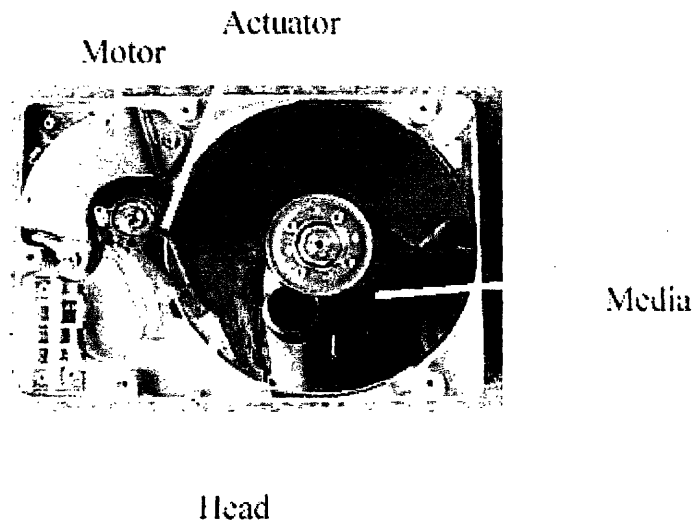

Figure 3-1: Typical setup of a HDD, showing main components. [1]

There is no question that HDDs will continue to evolve to higher recording densities. The industry has set itself a pace and the costumers are eager to get the latest advances in

magnetic storage. The question that is still to be answered is which will be the first company that achieves the production of a HAMR-based HDD. Intellectual property in this case is of vital importance to protect the strong investments that companies make on research and development.

However, because HDDs as we know them have been around for more than 4 decades, some components are well known to the industry. In fact hard disk drives have a structure that is standard to all manufacturers. Figure 3-1 shows the typical setup of a HDD.

Because HDDs involve numerous of parts and systems, and because research and development are carried out at several companies and universities, HDDs usually incorporate technologies that are licensed from third parties. Cross licensing in the magnetic recording industry is common practice.

To get a feeling of the large number of technologies involved in a HDD, Figure 3-2 lists some of the aspects that need to be considering when putting together a new HDD.

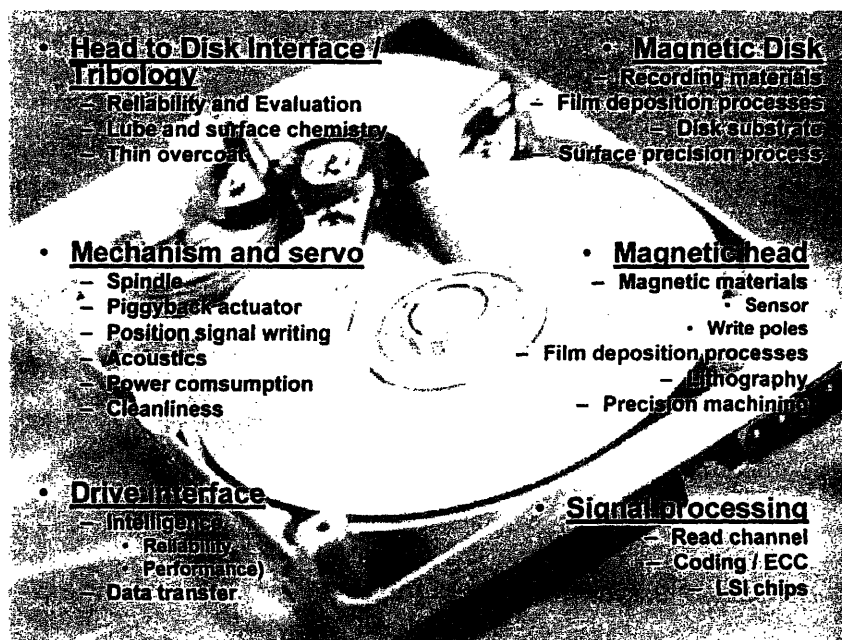

Figure 3-2: technologies involved in the development and production of current HDDs.

It is then obvious that the eventual introduction of HAMR will most likely involve licensing a number of patents that protect very specific aspects of HDD technology.

In an attempt to grasp how much intellectual property exists about HAMR, a patent analysis was carried out. The results are shown in Table 3-1.

Table 3-1: Shows summarizes the holders of patents in the magnetic recording industry, especially those patents related to Heat Assisted Magnetic Recording

	Total Patents	Magnetic Recording Patents	Thermally (or optically) Assisted M.R.
Seagate	2,304	1294 (56%)	18
Toshiba	20,561	448 (2%)	4
Sharp	10,411	190 (2%)	4
Hitachi (IBM)	537	32 (6%)	0

It can be seen that the IP regarding HAMR is mainly held by Seagate, Toshiba and Sharp. Hitachi, which acquired IBM's HDD division, has recently filed for some patents protecting their inventions in HAMR.

Seagate, a company dedicated to magnetic recording, as should be evident by the fraction of patents it holds related to magnetic recording, is the leader in I.P. when it comes to HAMR. Seagate's representatives are confident about the introduction of products using perpendicular magnetic recording in less than two years time [2].

Because magnetic recording is a mature technology, the intellectual property is very well protected by a large number of patents, both in the US and in Japan, which are considered the two countries in which most of the research is carried out currently. Some of these patents will now be analyzed

3.1 Patent Analysis

In an attempt to get an idea of the patents that exist in the field of HAMR, I have searched for patents that are relevant to this technology. I have focused on the US patents only. However, as has been said before, the research on HAMR is mainly done in the US and Japan. Japanese companies usually get US counterparts to their original Japanese patents. For this reason, making an analysis taking into consideration only US-issued patents can be considered a valid approach.

3.1.1 U.S. patent 6,714,370, Seagate Technology, March 2004:

“Write head and method for recording information on a data storage medium” [3]

This patent is one of the most advanced in HAMR intellectual property. It comprises a magnetic recording head design that incorporates a laser waveguide and a near-field focusing structure to reduce the size of the spot on the medium's surface that is heated by a laser.

The near-field focusing structure is shown schematically in Figure 3-3. It consists of four arms (marked 72, 74, 76 and 78) that resemble the bow tie structures seen in chapter 2. The gap through which the light is supposed to exit on its way to the medium (marked 92, 106 and 110) is said to be around 50 nm in the direction of the arrows. Without describing how such structure works, we can say it is one very sophisticated way of guiding the heat source towards the medium, even though the experimental results with near-field optics have not yet proved to be effective.

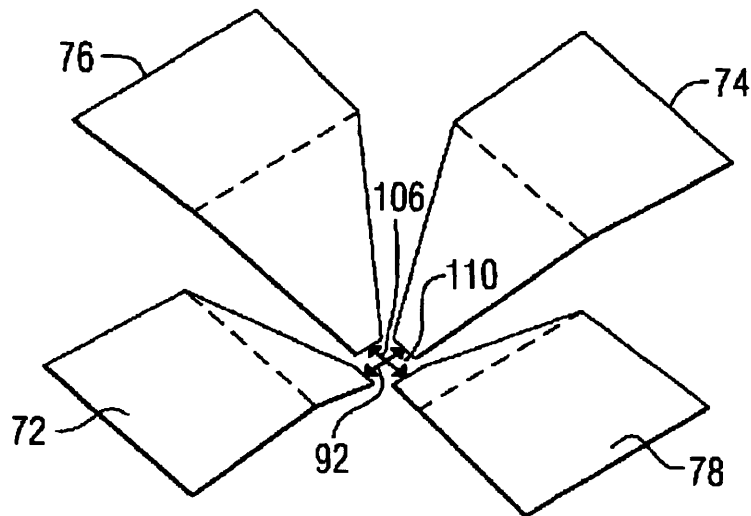

Figure 3-3. Near-field focusing structure protected by US patent 6,714,370. Numbers 72, 74, 76 and 78 make reference to the arms of such structure, while 92, 106 and 110 indicate the gap (~50nm). [3]

The patent claims include descriptions of the recording head, with and without the near-field focusing structure, as well as the HDD that could be produced using this technology. It also protects the recording process, in which it gets very specific about the geometry and timing of the application of the heating and recording fields.

3.1.2 U.S. patent 6,762,977, Seagate Technology, July 2004:

“Laser assisted magnetic recording apparatus and method” [4]

Seagate Technology once again files a patent that reflects their proposals in HAMR. This patent protects a HDD laser assisted magnetic recording system that includes a semiconductor laser and a magnetic write coil integrally formed into a slider. It also considers the possibility of using this head in both, longitudinal and perpendicular magnetic recording, with the appropriate changes in the design of the recording coil.

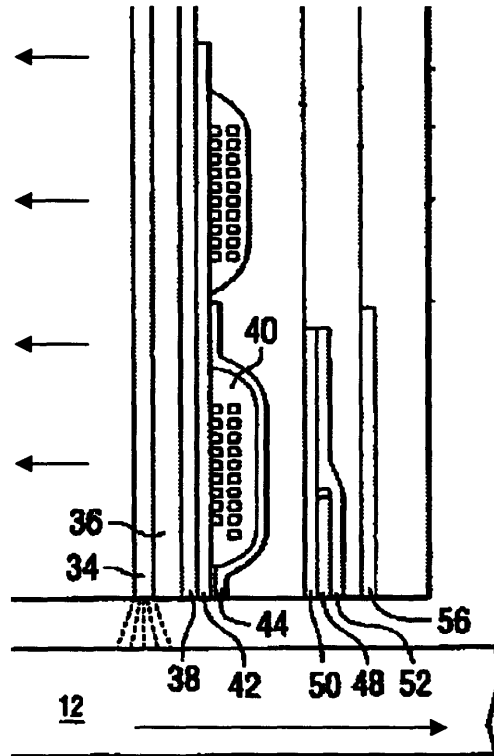

Figure 3-4. Schematic view of the slider with an integrated laser diode protected by US patent 6,762,977. From Left to right we see the laser diode (34), the recording coil (40, 42 and 44), as well as the GMR reader (48). [4]

Figure 3-4 shows a schematic view of the slider protected by US patent 6,762,977. Such slider includes a laser diode (34), a magnetic recording coil (40, 42 and 44. Shown for a longitudinal recording system) and a GMR read head (48). As can be seen from the figure, the laser is placed in the leading edge of the slider. That is the most common setup in HAMR, because it allows for tuning of the distance that separates the thermal and magnetic fields, and thus permits proper timing to get the most convenient results in terms of recording areal density (see section 2.2.5).

Besides claiming the slider with the integrated laser diode, the method of manufacture of such slider is also claimed. A schematic view of the slider during fabrication is shown in Figure 3-5. Note that the right end in the image needs to be

trimmed to expose the read and write heads. It is obvious that a lot of precision is required to finish this slider. An excellent surface finish is a must with the reduced flying heights HDDs required nowadays.

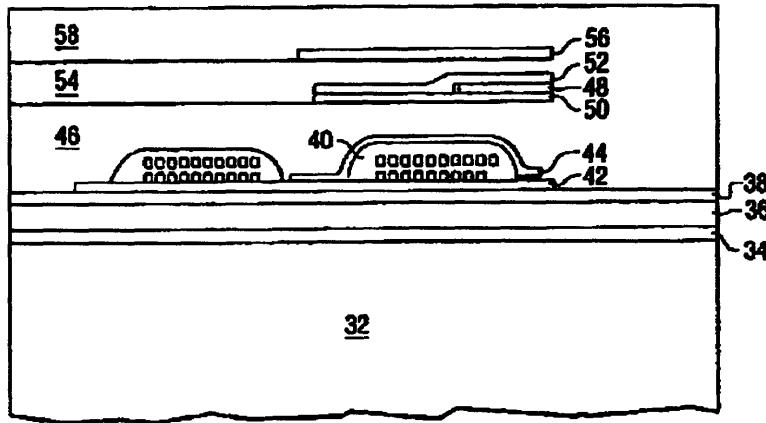

Figure 3-5. Method of thin film microfabrication of the slider claimed in US patent 6,762,977. The right end of the device needs to be trimmed to expose the read and write heads. [4]

In this same patent, the possibility is mentioned of including a “laser aperture” or an “emission edge”, which are two different means of reducing the size of the light spot that is projected onto the recording medium.

3.1.3 U.S. patent 6,636,460, Toshiba, October 2003:

“Thermally-assisted magnetic recording method and thermally-assisted magnetic recorder” [5]

This patent, which was previously released in Japan, comprises the design of a magnetic recording device using either a laser beam or an electron beam as sources of thermal energy. It also details the magnetic recording method, in which they have been very specific about the heating-recording timing.

The slider (see Figure 3-6) can emit either a laser or an electron beam (21) towards the surface of the medium (14), heating up the magnetic recording layer (13) and making it writable.

The timing in this system is very carefully detailed because it is the main factor that enables ultrahigh density recording. The heated-spot size does not necessarily have to be the same as the bit size. In Figure 3-6 we can see the area that is heated by the beam is larger than the bit length, and in fact, even the recording pole can be larger than the bit

itself. After the medium is heated up, sufficient time is given for it to cool down at the magnetically frozen point (MFP) so that the area that is exposed simultaneously to both fields (thermal and magnetic) is effectively smaller than the areas upon which the fields are applied.

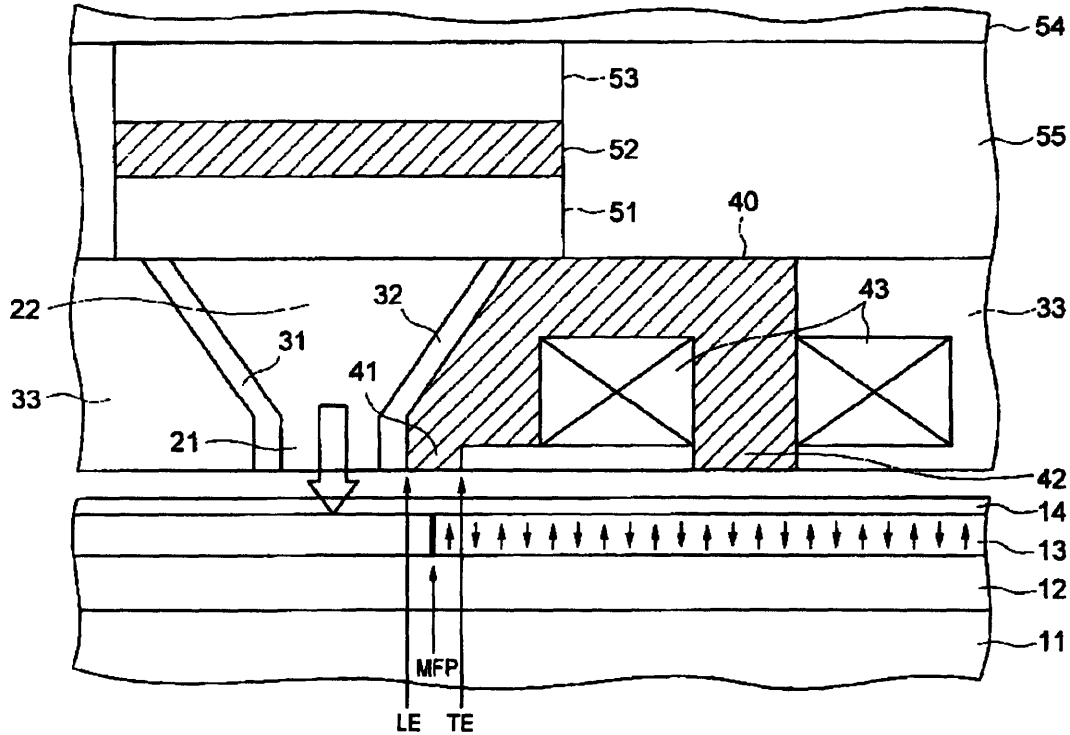

Figure 3-6. HAMR slider. US patent 6,636,460 protects this setup, including either a laser or an electronic beam (21). The magnetically frozen point (marked MFP) indicates the point at which the temperature of the medium is low enough to make writing not possible by the recording coil (41). [5]

The claims US patent 6,636,460 includes involve the process of recording, including some figures related to the timing and dimensions of the spacing between the heating device and the writing head; it also includes the particular devices that could be produced using this design.

3.1.4 U.S. patent 6,493,164, Toshiba, December 2002:

“Magnetic recording apparatus and method of magnetic recording” [6]

Previously released in Japan, this US patent describes a magnetic recording medium and the design of a magnetic recording device. The medium in this case is a two-phase polycrystalline medium. This patent is also specific about the heating-recording timing in

the writing process. It also mentions explicitly the use of the magnetic anisotropy reduction due to the heating of the medium.

This patent is centered on the recording medium, which has to be engineered to have a thermal magnetic behavior given by Equation 3-1, where T stands for absolute temperature, $K_u(T)$ is the uniaxial anisotropy density as a function of the absolute temperature, $K_u(T_a)$ is the uniaxial anisotropy at room temperature and t is the elapsed time after the magnetic write field is applied.

$$\frac{T}{RK_u(T)} = \frac{T}{\frac{K_u(T)}{K_u(T_a)}} < \frac{11200}{\ln(t) + 20.72} \quad \text{Equation 3-1}$$

The claims on this patent protect the ‘magnetic recording apparatus’ comprising the two-phase polycrystalline medium. It is mentioned that such a medium could have coercivity greater than 4 kOe at room temperature and could be either a Co-based alloy or a rare-earth transition metal (RE-TM) alloy.

3.1.5 U.S. patent 6,403,619, Sharp, August 2003:

“Magnetic storage medium and heat assisted recording and reproduction method” [7]

Also issued earlier in Japan, this patent describes a recording medium that works in the compensation temperature range and its corresponding magnetic recording head together with their recording and reproduction method.

Antiferromagnetically-coupled materials can have a compensation temperature at which the field necessary to demagnetize the domains is a maximum. If such temperature coincides with room temperature (or with the base operating temperature of the devices), magnetic bits can be stable until heated up for writing.

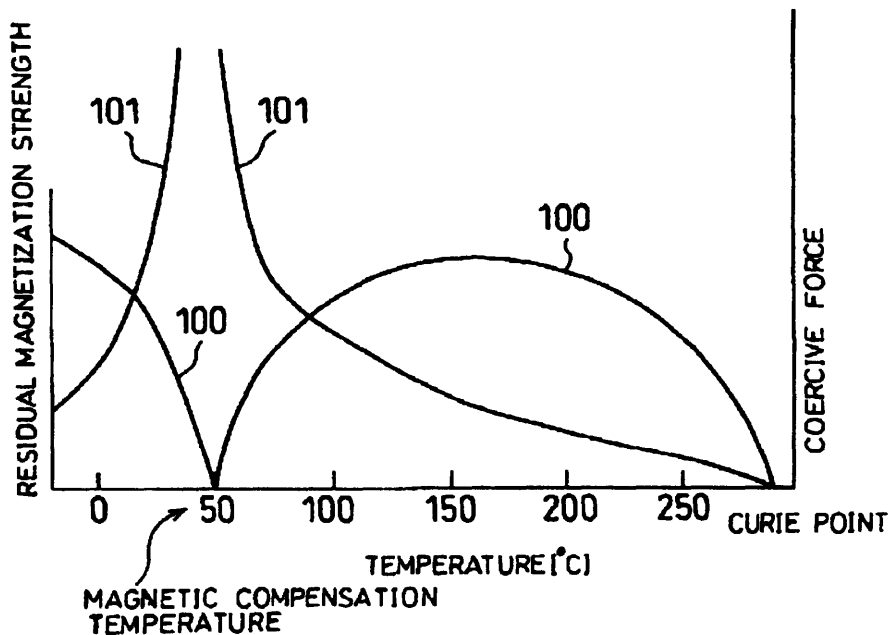

Figure 3-7. US patent 6,603,619 protects the intellectual property of an antiferromagnetically coupled medium showing a compensation temperature around room temperature. The thermal behavior of the residual magnetization strength (100) and of the coercive force (101) are shown as they appear on the patent document. [7]

It is worth mentioning that the media like the one proposed by this patent need to be heated both for writing and reading because the magnetic field that emanates from the bits is nearly zero at the compensation temperature (which in this case coincides with the normal operating temperature).

This patent's claims protect the antiferromagnetically-coupled multilayered medium, the heat-assisted recording and reproduction method, as well as the process of recording. The characteristics of the medium are specified, saying the saturation magnetization of the recording layer reaches a maximum between 150 and 250°C, while the compensation temperature of the layer is said to be in the range from 40 to 100°C.

3.1.6 U.S. patent 6,741,524, Toshiba, May 2004:

***“Thermally-assisted magnetic recording and reproducing device
having an electron beam thermal source” [8]***

This very recent patent by Toshiba addresses the challenge imposed by the diffraction limit on systems using optical thermal sources. It proposes the use of an electron-emitting source to heat up the surface of an otherwise unwritable medium.

According to this patent, the electron beam can be of one of four kinds: field emission type, thermoelectronic emission type, photoemission type or tunnel electron emission type. Using an electron beam instead of an optical source, this patent claims that a spot size of 10 nm is achievable. To guarantee a good resolution, the head to disk spacing is made to be shorter than the mean free path of the electrons that are emitted from the slider. To facilitate this requirement, the use of reduced pressure inside the HDD unit is considered.

Alternatively, this patent considers the possibility of using the pole of the write head as an electron emitter to heat up the medium directly below the thermal field.

Figure 3-8 shows a view of the slider proposed by US patent 6,741,524. The electron emitter (40) produces a beam of electrons (41) that heat up a spot (63) on the surface of the magnetic recording medium (61). The magnetic coil has two poles, one that concentrates the flux over a small area for writing purposes (13) and another one that serves as a return path to close the magnetic circuit (12). The layer under the magnetic film (62) is the channel that conducts the magnetic flux from one pole to the other. The head-to-disk spacing (17) is said to be between 0.5 and 10 nm.

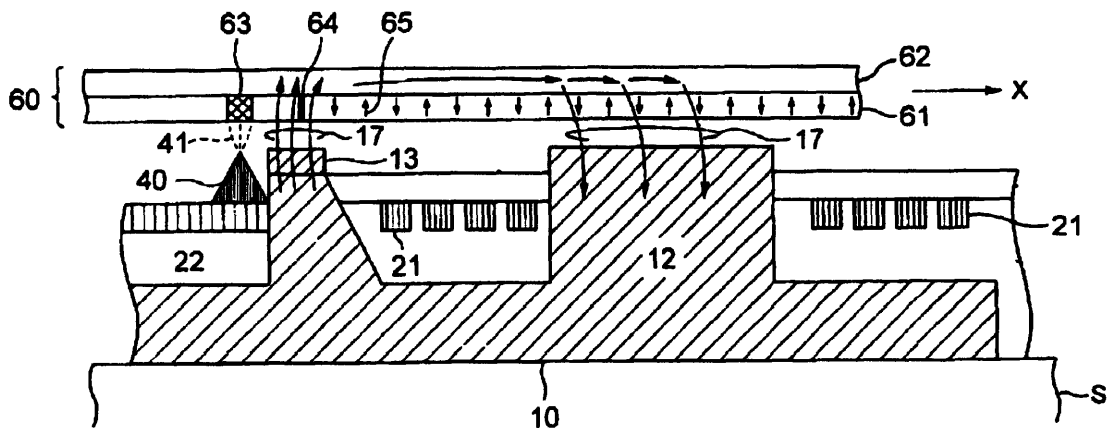

Figure 3-8. Schematic of a HAMR slider using an electron beam (40) as the heat source. [8]

The claims of this patent protect a thermally-assisted magnetic recording system that contains an electron beam and a magnetic pole, having a head to disk spacing shorter than the mean free path of the emitted electrons. They also cover a system that uses the magnetic writing pole as an electron emitter.

3.2 Summary

From studying the US-issued patents related to HAMR, it can be noticed that they are usually very specific about the slider configuration and the recording process. Some of them include precise relations between the relative dimension of the head, or the spacing between the writing head and the heating device. Other patents concentrate on the recording medium only, being specific about chemical compositions in some cases [9,10,11].

One could think the existence of all these patents could make it difficult to come up with a novel device that is patentable. However, in my opinion it is possible to obtain a patent for a given configuration of a specific HAMR device as long as enough attention is put into the characteristics that make the device unique. Such characteristics could be related to the physical dimensions of a part of the device, the recording process and the timing it requires, the fabrication of the device, the composition and thermal characteristics of the magnetic medium, etc.

It can be then said that having obtained a good combination of head and recording medium, protecting it with a patent would be possible even if a lot of patents already exist. From the nature and geometry of the device, enough distinctive characteristics can be included in a patent that protects the whole systems and the parts that comprise it.

On the other hand, the possibilities of protecting a complete system by getting a single patent that protects all the major essential features in a HDD are less than slim because of the complexity of these systems.

Unfortunately this apparent ease in differentiating a particular device from the ones protected by the existing patents could in fact be an unwanted characteristic for a company, since some other company could base a new design on an existing patent while making enough changes in it to avoid infringing any I.P.

No matter how effective a patent could be in such case, we also need to realize that in an industry that evolves as quickly as the consumer electronics industry, a particular design has a much shorter life than the patent that protects it. This means that even if we could come up with an effective design of an HAMR system and we could get enough IP to fully protect it, this design would not last more than a few years.

As has been discussed before, in the magnetic recording industry intellectual property could more effectively be used to have certain leverage upon the competing companies. Therefore the importance of patenting in HAMR is not restricted to the legal protection of the IP.

Cross licensing could be an effective way of protecting one company's IP by negotiating with the major competitors and reaching an agreement from which all parties can benefit.

References

- 1 J. P. WANG, *The history of magnetic recording*, University of Minnesota, 2003.
- 2 D. WELLER, *The future of magnetic recording*, IEEE invited talk at MIT, 2004.
- 3 US patent 6,714,370, T. W. McDANIEL and T. R. VALET, Seagate Technology, March 2004.
- 4 US patent 6,762,977, E. C. GAGE et al., Seagate Technology, July 2004.
- 5 US patent 6,636,460, J. AKIYAMA et al., Toshiba, October 2003.
- 6 US patent 6,493,164, A. KIKITSU and K. ICHIHARA, Toshiba, December 2002.
- 7 US patent 6,603,619, K. KOJIMA et al., Sharp, August 2003.
- 8 US patent 6,741,524, K. ICHIHARA et al., Toshiba, May 2004.
- 9 US patent 6,555,252, D. J. SELLMYER et al., Board of Regents of the University of Nebraska, April 2003.
- 10 US patent 6,657,813, Y. NISHIDA et al., Hitachi, December 2003.
- 11 US patent 6,593,014, Y. OGIMOTO et al., Sharp, July 2003.

4 HAMR-based HDDs in the marketplace

4.1 Applications of HAMR

HAMR is a technology that has been conceptualized and is being developed specifically to be used on HDDs. The application of HAMR is strictly in extending the capacity of the recording industry to keep up with the pace it has set itself over the last 5 decades, a pace of increasing information density that continues to have an insatiable market. This extension will happen as HDDs with higher areal densities are produced and taken to the marketplace at prices that are both competitive and consistent with the price that HDDs have had in the recent past. Therefore, we can say HAMR is a substitutional technology.

Speaking about the range of application of HAMR is speaking about the range of application of HDDs. There is a historically strong market for high-density hard drives in the computer industry. In a given year, the number of HDDs that are produced world wide is slightly higher than the number of personal computers that use them as non-volatile storage devices.

Today, improvements in areal density of HDDs have led the technology in a new path. Besides the use of HDDs as non-volatile memory units in computers, whether mainframes, desktops or laptops, miniaturization of HDDs has made it possible to introduce them in new and exciting portable applications.



Figure 4-1. IBM's 4Gb Compact Flash hard drive: an example of the reduced size HDDs can achieve while having a high storage capacity thanks to the possibility of recording at high areal densities. (actual size) [1]

One very popular application, Apple's Ipod (and Ipod Mini), both based on HDD technology, have made clear that the incorporation of HDD into portable devices is a strong emerging market. There were 700,000 Ipods shipped in 2003. This gives us an idea of the potential of portable applications.

Almost every device we use for electronic communication, information or entertainment could soon have a hard drive. Camcorders could hold hundreds of hours of DVD-quality video, eliminating forever the worry about running out of tape; hand-held digital music players may come pre-loaded with thousands of hours of music, which you would pay to unlock; cell phones could eventually be able to store many hours of low-resolution video.[2] In fact with the recent introduction of imaging capabilities (photo and video) into portable phones, the memory requirements of such devices have increased greatly, making them each time more suitable for the use of HDD technologies. Figure 4-2 shows three examples of products based on HDD technology. All these products are currently available in the market.

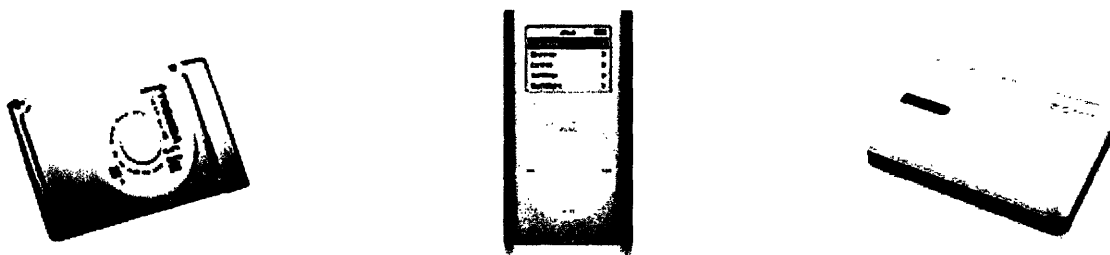

Figure 4-2: From right to left: Toshiba's PC card: 5 Gb, 1.8in HDD; Apple's iPod Mini: 4 Gb, 1in HDD; Sony's Giga Vault: 80 Gb, 2.5in (USB) HDD.

However, portable applications are not the only new market for HDDs. Consumer electronics have recently started including hard drives as their main memory devices. Microsoft's Xbox demonstrates viability of hard drive in high-volume consumer application. TiVo has effectively incorporated the possibility of storing television shows according to user preferences, all thanks to the versatility of HDDs. Panasonic, Philips, Pioneer are now selling DVD recorders with incorporated hard drives.

It should then be evident that HAMR, as any other substitutional technology, has one obvious, well-defined market in the personal computing industry. In fact, it is due to the existence of this market that is actually driving the technology. But if HAMR technology

could be incorporated into portable applications and consumer electronics, there could be a new and large emerging market waiting to be satisfied.

4.2 Market Assessment

Because HAMR is a substitutional technology, the way it can reach the market is through its implementation in HDDs. The market for HDDs is very well defined and its size is well known. HDDs have traditionally been used in personal computers. The growth of the HDD market has followed the same trend as the computer industry market. Nowadays, HDDs are beginning to be introduced in new applications and are expected to show even larger growth in the years ahead.

The approximate size of the market for HDDs in PC applications is \$22 billion/year [3]. In the last 12 months the market experienced a growth of 12% and experts say it will continue to increase in size, achieving a compound growth rate of 40% towards year 2007. Last year, 261 million HDDs were shipped worldwide.[4]

Seagate is the world leader in HDD production. It makes HDDs for all types of computers, from high-end servers and mainframes to laptops. It is a US-based company with manufacturing facilities in Singapore and distribution in America, Asia and Europe. Its market share is around 29% and it has 42,000 employees worldwide [1].

Maxtor has reported to have roughly 21% of the market. Started in 1982, Maxtor merged with Quantum in 2000 and since then has been the second largest competitor in HDD production. Today it employs 43,000 people and has facilities in Singapore and South Korea [5].

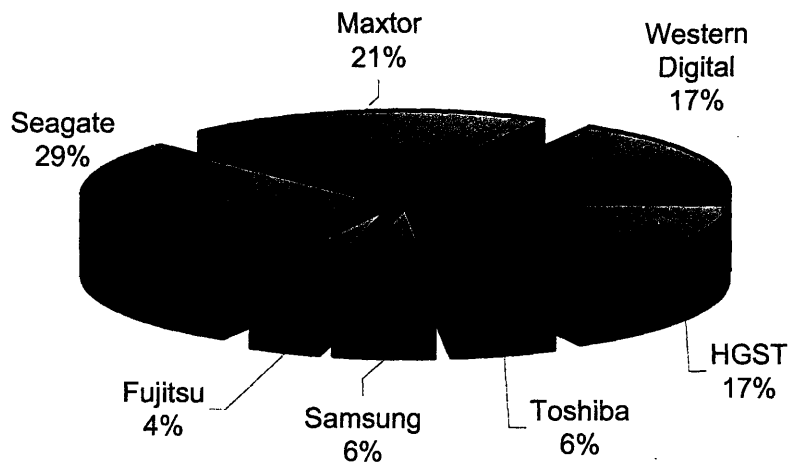

Figure 4-3 Market share of major HDD manufacturers. [3] 2003.

Western Digital, which recently purchased Read-Rite corporation, holds just above 17% of the world's HDDs market and employs 11,500 people. With manufacturing plants in Malaysia and Thailand, it has become the fastest growing HDD company over the last two years.

Hitachi, after having acquired IBM's HDD business in 2003 to form Hitachi Global Storage Technologies, has become the fourth largest manufacturer, with almost 17% of the total HDD shipments worldwide, just below Western digital. With 21,000 employees worldwide it makes high end hard drives and has continued IBM's Microdrive™ developments, launching in 2003 a 4 Gb compact flash card HDD.



Figure 4-4. Hitachi Global Storage Technologies' 4 Gb CF HDD. (actual size). [6]

These four companies are the leaders in this industry and thus are the ones everyone studies for future market and technology trends. They have plants both in the U.S. and

abroad. In fact, 80% of the HDDs that are produced in the world are assembled in Singapore.

Besides the main independent companies that manufacture finished hard drives, there are many medium size companies that act as suppliers to the leaders. Most of them concentrate on only one or two of the main components of hard drives, such as the medium, the recording head, the motor, the servo control, etc.

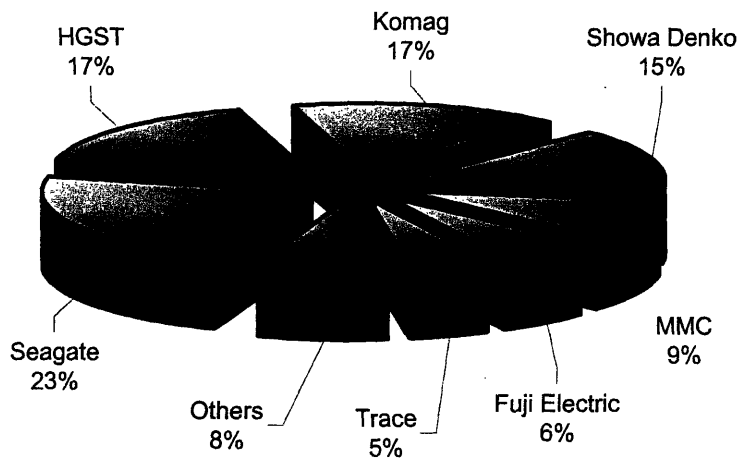

Figure 4-5 Rigid disk media market shares (from a total of 110 million units). 4th quarter 2003.

We have mentioned the size of the HDD world market is around 270 million units per year. Computer HDDs make most of that market. However, in the last few years the hard drives have successfully been introduced in the consumer electronic market. We can then speak about two different markets for the application of HAMR-based HDDs. One is the established market of computer storage, and the other one is the emerging market of portable applications and consumer electronics.

Worldwide compressed audio market is forecasted to ship 90M units for 2003. That is why products like apple's Ipod are of so much interest for the magnetic recording industry. TiVo, the personal video recorder (PVR) has 624,000 subscribers nowadays, and that figure is expected to reach 1 million by the end of 2003 and 6 million by 2006 (according to predictions by Morgan Stanley). Cable TV companies are also interested in in HDD technology. Motorola, Scientific-Atlanta, Pioneer and Pace have already introduced hard drives in PVR-equipped cable boxes. [7]

One of the experts when it comes to the economics and behavior of the HDD industry, Clayton Christensen, has said that only one thing can be known about market predictions in the magnetic storage business: they will always be wrong [8]. However, as a tool to get an idea of the general tendencies in portable and consumer electronic applications for HDDs, Figure 4-6 shows the expected growth of the segment of the world HDD market corresponding to mobile applications. That sector together with enterprise sector are the ones that will experience more growth in the coming years. The desktop segment will grow only 5%. [7]

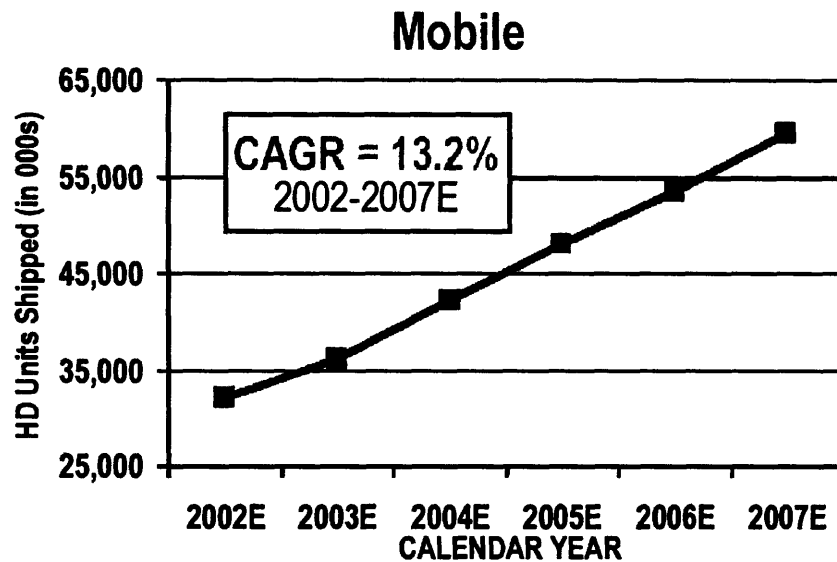

Figure 4-6 Growth of market for mobile applications of HDDs (projection). [7]

But as said in section 4.2, the novel applications for HDDs are not only in portable devices. The consumer electronic market, as a whole, has a lot to offer to the magnetic recording industry, when it comes to demand for new and affordable high storage capacity products. Today, one can buy a HDD-equipped PVR for as low as \$250.

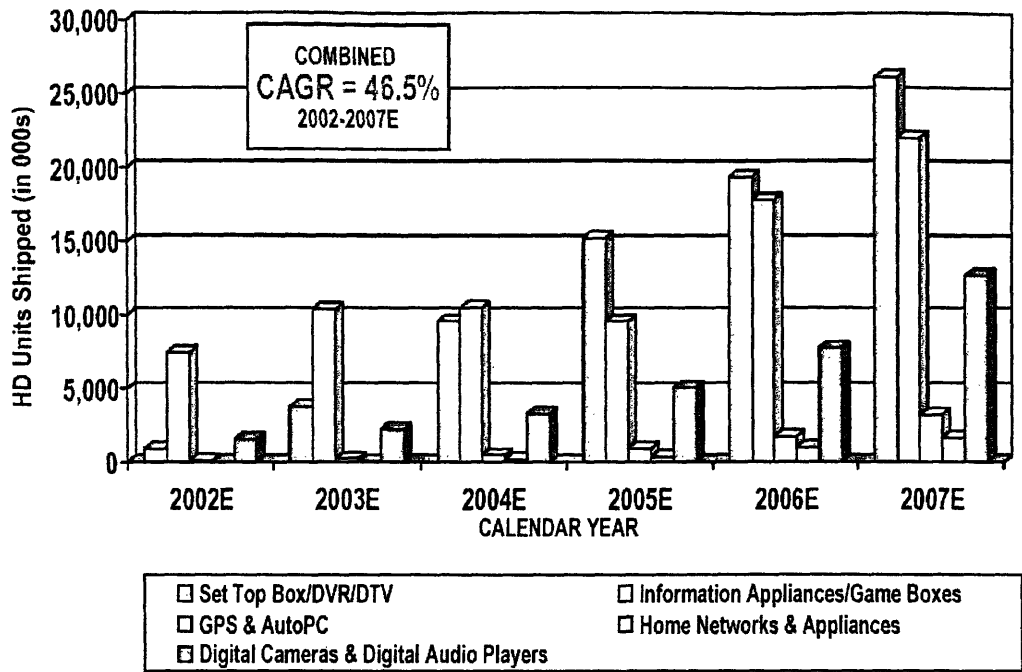

Figure 4-7 Growth of market segment for non-traditional applications for HDDs (projection). [7]

The reasons why magnetic recording is financially relevant can be understood from the previous information. It can also be realized that because the traditional HDD market is a mature one, competition is tough and there are some companies that are very well known as the leading entities on the industry.

Competition in the magnetic recording industry is in fact so fierce that analysts estimate the industry as a whole has lost money during the past 30 years [9]. It is not certain whether the new technologies can change that trend. However, with the introduction of HDDs into new emerging markets, a whole new spectrum of possibilities is open for companies who are willing to develop products outside the computer business. The possibility to make profit exists for a company that offers a reasonable competitive advantage in a market that grows at the rate like the consumer electronic market.

4.3 Cost considerations

Cost assessment is basic in any economic analysis. The costs associated with the introduction of HAMR in the production of HDDs are difficult to model due to the

complexity of the systems. However, we can get an idea of how the introduction of HAMR will impact the production of HDDs.

From what is known of the technological requirements of HAMR, the materials and the processes that will be needed to produce a hard drive will most likely be slightly more expensive. However, the result will be an increase in the recording density that hopefully can make up for the higher production cost.

From this perspective, without making any formal calculations about the eventual cost of HAMR-based HDDs, we can infer that cost per device will not be the competitive advantage such a product will offer. On the other hand, we know an increase in the magnetic recording density, which can be reflected in the overall storage capacity of the device, is the ultimate goal. In any case, whether the cost of a HDD increases or decreases, the figure of merit is not the cost alone, but rather the cost per megabyte. Thus if we manage to increase the recording density, even if the production costs are slightly higher, we would have a competitive advantage when it comes to “price per megabyte”.

HDDs require a large amount of microfabrication on their production. Start-up costs for a company that intends to participate in the HDD market, either as a supplier of parts or as an integrator, can be prohibitively high. Specialized fabrication facilities, highly trained personnel, and fabrication equipment are some of the concepts that make microfabrication so expensive. Figure 4-8 schematically shows the results of a study made considering the number of start-up companies that achieved \$100 million in revenues in at least one year between 1976 and 1994.

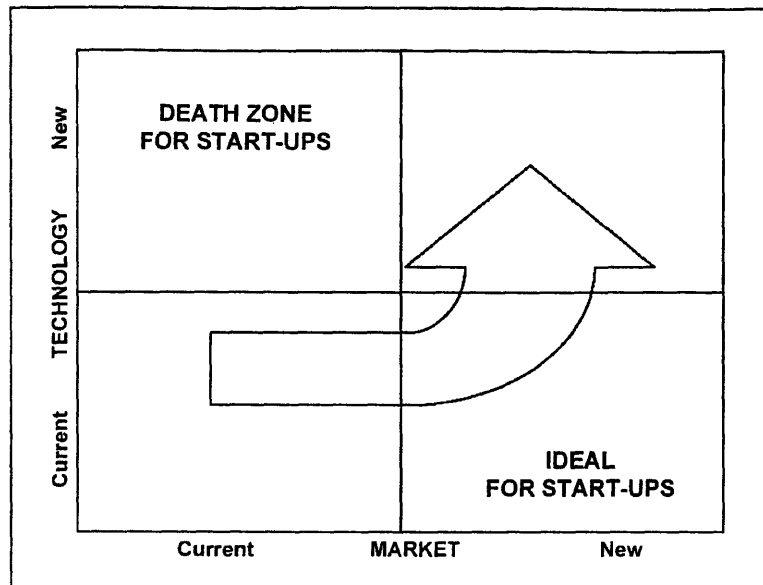

Figure 4-8 Christensen's map of success for startups in the HDD industry. [8]

The results indicated that out of 10 companies that started-up trying to use a new technology in an established market, all of them failed. The “ideal zone” for start-ups is in fact on the opposite corner of the diagram, using off-the-shelf technology to introduce it in a new market. The arrow in the diagram indicates the natural trend in which companies grow by taking on new markets either with new or with existing technologies.

One more challenge for small sized companies is that, as usually happens with microfabricated devices, the only way to make profits is by having economies of scale. Historically the companies that have survived in the industry are not necessarily the ones that are first-to-market, but rather the ones that are first-to-volume [10]. Fortunately the HDD industry has sales in the order of millions of units a year. So costs per device can be cut down to a minimum.

It can be then said that thinking about starting up a company based on HAMR technology would not be a good option for investment. However, history has also demonstrated that spin-off companies that separated from large corporations have had success when introducing new technologies. This fact needs to be considered by the leading companies of the industry when thinking about introducing new technologies, such as HAMR, in the marketplace.

4.4 Economic challenges in HDD production

As has been mentioned in chapter 1, the roadmap of magnetic recording technologies has show great improvements in storage density over the last 50 years. Figure 4-9 shows the accelerated rate at which the areal recording density has increased since 1975.

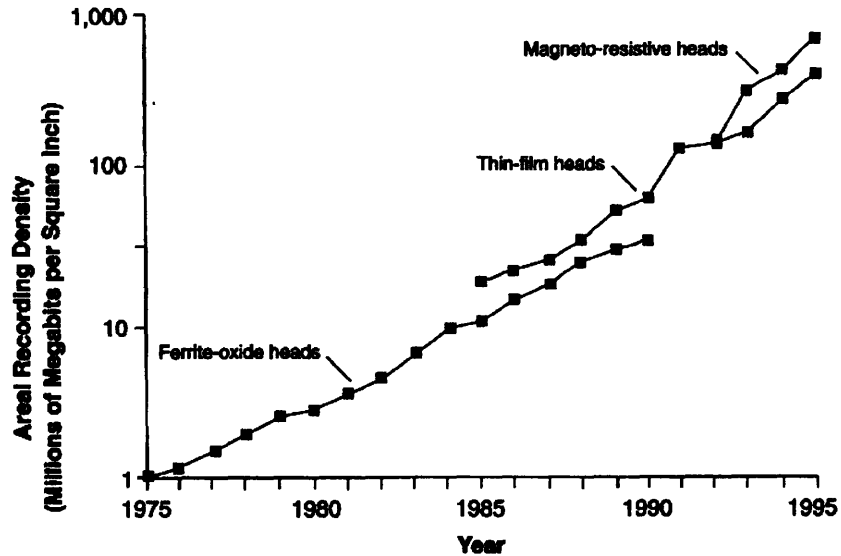

Figure 4-9 Roadmap of the HDD industry. [8]

On the other hand, as was also mentioned in chapter 1, the price of hard drives has kept on going down during all these years. Figure 4-10 shows that price per megabyte has dropped at an accelerated rate as the industry has continued to produce more and more HDDs.

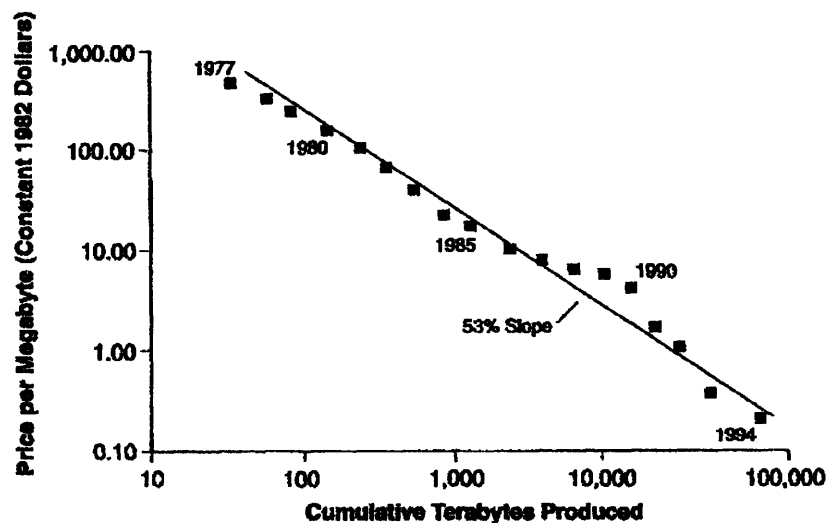

Figure 4-10 Development of price per megabyte relative to total produced HDD capacity. [8]

In fact, price per gigabyte will decrease from \$40 in 2002 to \$8 in 2006. More recent studies show that disk storage system terabytes over the next three years will grow over 50% (CAGR), while disk storage system market revenue will grow at only 0.8% (CAGR). As may be inferred, this two trends, when considered together, have imposed very severe restrictions on the manufacturers of HDDs.

Naturally, regardless of the severity of the conditions that the industry faces, it will not cease to grow. The opportunities for investment are thus still there, but careful attention needs to be put into current market trends to avoid economic failure.

4.5 HAMR: disruptive technology?

A disruptive technology is one that has the ability to surpass an existing technology without necessarily being better in performance. The main strength of a disruptive technology is that it uses well known technologies but targets an emerging market.

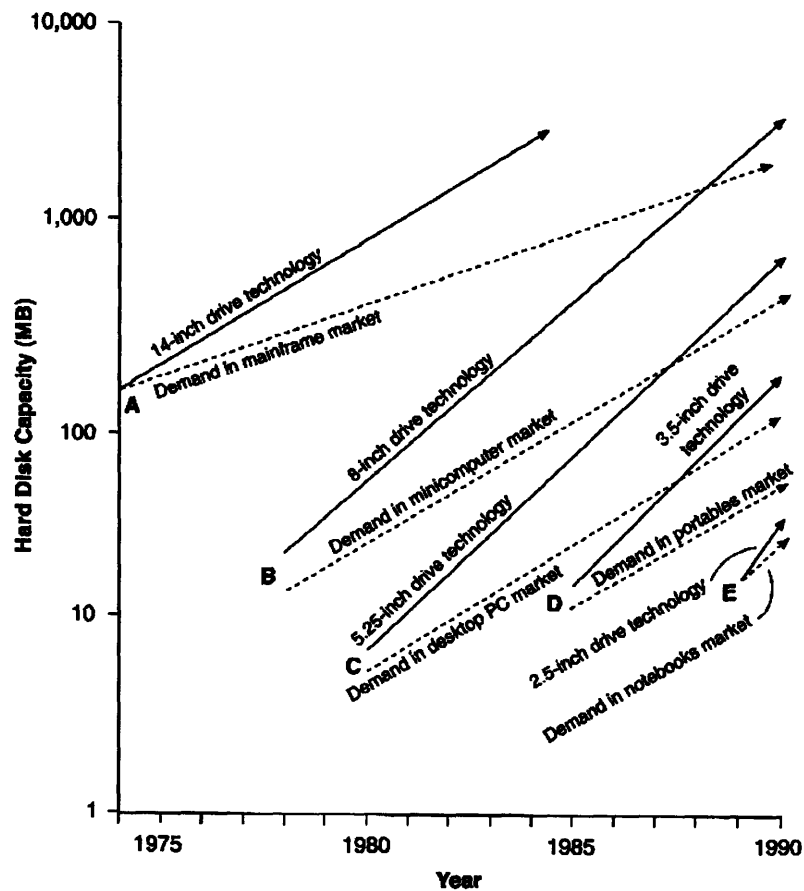

Figure 4-11 Disruptive changes in HDD architectures. [8]

The success of a disruptive technology is in adjusting to customer needs better than a traditional technology, even when this means its performance characteristics are initially not as good as the ones of the established technology. A technology is “disruptive” because *apparently* it is not subject to traditional managing principles, such as listening to customers, investing in developing the technologies that customers prefer, carefully studying market trends, etc. “Listening to customers” has in fact led large companies to bankruptcy.

The main mistake big companies have made is that they have listened too much to traditional (established) markets, and have ignored the changing nature of customers, sometimes offering them technologies they do not need or want. Several disruptive technologies have been introduced in the HDD market. Usually such technologies have coincided with architectural changes in HDD products. Figure 4-11 shows, for instance, how the performance that manufacturers offered in 8-inch HDDs was increasing more rapidly than customer needs. The introduction of 5.25-inch HDDs by companies like Seagate and Quantum in the early 80s was disruptive because being based in existing technologies, it targeted a new market (the mini-computer market), and even though it originally offered less storage capacity than existing 8-inch HDDs, it adjusted better to its own market. Eventually, the new technology reached the mainframe customer demand curve and was then able to fully substitute the previous platform. The disruptive introduction of 5.25-inch HDDs led IBM to lose its leadership in the industry and propelled two young companies into economic success.

Figure 4-11 also shows that disruptive changes have historically been related to modifications in the architecture of HDDs, unlike “minor” improvements, such as the changes in head technology (seen in Figure 4-9). That is why in my opinion, the introduction of HDDs in new, portable formats could be a disruptive technology. HAMR could be the “minor” modification that allowed the miniaturization of high capacity HDDs for non-traditional devices.

4.6 Investment opportunities in HAMR

Because of the fact that start-up costs are so high in the HDD industry, making a start-up company based on HAMR is not a good option in the short term. However, there

are business opportunities that need to be considered both for the companies that are already in the industry and for individuals who seek a career.

The leaders in magnetic recording acknowledge the fact that HAMR is a technology that could contribute to their survival in the market. A lot of research is done inside the companies and press releases reveal their advances in this research fields, often telling in advance what can be expected in the marketplace in the coming months.

Obviously the companies that have larger shares of the market are the ones that are more interested in developing the technologies that will help them maintain their leadership positions. HAMR is an opportunity that cannot be overlooked by any of these large companies, for it will very likely define the future of magnetic storage technologies.

This is then the first business opportunity in HAMR. HDD manufacturers must recognize the opportunity of conducting research in HAMR. Those companies not only have the money to support research but are also the ones that most likely profit from the results that come out of it. Of course the experience of the people within the companies and the knowledge that can only be gained by trial and error when mass producing HDDs are the industry's most valuable assets when it comes to HAMR research.

On the other hand, research is also done at universities. Government funding is important in fundamental research because it does not restrict the field of study as much as with individual funding; companies also provide funding for research in universities but short term results are often expected in return and the direction of the research is very well delimited by the sponsors.

Universities can also benefit from investment from companies. In fact, some companies prefer to fund research at universities because it is more cost effective for them. A company would need to spend a lot of money in testing equipment, salaries and often consulting from experts in the field to achieve the same results a research group at a university could get, not to mention the fact that universities are often multidisciplinary in their research and thus add new perspectives to the solution of problems.

Investing in research at research in universities is one source of mutual benefit. Money is usually a limiting factor in research, but the costs associated with it are pro-rated among all the research that goes on in a university.

References

- 1 Seagate Technology's website: www.seagate.com
- 2 M. LANGBERG, *Storage limits? What storage limits?*, Mercury News, www.siliconvalley.com, March 26, 2004
- 3 The International Disk Drive Equipment and Materials Association's website: www.idema.org
- 4 Western Digital's website: www.westerndigital.com
- 5 Maxtor Corporation's website: www.maxtor.com
- 6 Hitachi Global Storage Technologies' website: www.hgst.com
- 7 M. MASSENGILL, *The Wave of Change: Storage Rises to New Challenges and Opportunities*, Western Digital Corporation, IDC Storage Forum, 2003.
- 8 C. M. CHRISTENSEN, *The Innovator's Dilemma*, Harvard Business School Press, 1997.
- 9 C. D. MEE and E. D. DANIEL, *Introduction to Magnetic Recording, the First 100 Years*, IEEE Press, 1999.
- 10 B. (Y.-I) LEE, *Analysis of the hard disk drive gray market: causes and cures*, MIT MBA thesis, 1998.