

Inchworm Car Seat Drive:  
Designing a linear actuator that mimics inchworm motion

by

Chun hua Zheng

Submitted to the Department of Mechanical Engineering  
in Partial Fulfillment of the  
Requirements for the Degree of

Bachelor of Science

at the

Massachusetts Institute of Technology

June 2001

© 2001 Chun hua Zheng  
All rights reserved

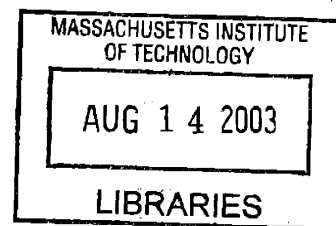

The author hereby grants to MIT permission to reproduce and to  
distribute publicly paper and electronic copies of this thesis document in whole or in part.

Signature of Author:

\_\_\_\_\_  
Department of Mechanical Engineering  
May 11, 2001

Certified by:

\_\_\_\_\_  
Ernesto E. Blanco  
Adjunct Professor  
Thesis Supervisor

Accepted by:

\_\_\_\_\_  
Professor Ernest Cravalho  
Chairman of the Undergraduate Thesis Committee

ARCHIVES

# **Inchworm Car Seat Drive: Designing a linear actuator that mimics inchworm motion**

By  
Chun hua Zheng

Submitted to the Department of Mechanical Engineering  
At the Massachusetts Institute of Technology on May 11, 2001  
In partial fulfillment of the requirements for the  
Degree of Bachelor of Science

## **Abstract**

A continuing goal in the automobile seat drive industry is to design lighter, smaller, more economical seat drives that offer excellent long-term performance. The way to achieve this goal is to minimize the number of parts and part complexity while meeting all safety and functional requirements. Current seat drives which use motorized lead screws are large and heavy. An alternative solution that the industry is exploring to replace the lead screw seat drive is a simple linear actuator. The goal of this project is to design an inchworm motion linear actuator that may be used as part of the seat drive system to provide fore-aft motion. The resulting final design is a simple system that consists of two modules, an actuation module and a clamping module. The actuation module is a simple motor-wobble plate assembly and the clamping module consists of spring-loaded jamming plates. The final prototype succeeded in inching the shaft forward in one direction, but failed at shifting directions. This failure can be remedied in future work by the introduction of an actuation guide plate as well as the more accurate and detailed machining of components.

Thesis Supervisor: Ernesto E. Blanco  
Title: Adjunct Professor of Mechanical Engineering

## **Acknowledgments**

I am grateful to many people who have helped me throughout the course of this year-long project. I would first like to acknowledge Professor Blanco for being a wonderful, encouraging advisor. He has given me invaluable help and advice not only on the subject of engineering design, but also on the subject of life.

I would like to thank the Lear Corporation for their resources and my 2.72 team members Luke Massery, Daniel Sandoval and Rory Pheiffer for their spectacular job on the inchworm project and for being super fun people to work with.

Fred Cote of the Edgerton Student shop has helped me tremendously with the construction of the inchworm prototype. Thanks Fred!

Thanks to my roommate Nataliya for being so tolerant and letting me clog the room with tools and gadgets galore.

Finally, I'd like to thank friends, family and professors for their moral support throughout the years.

# Table of Contents

<b>Title Page</b>	<b>1</b>
<b>Abstract</b>	<b>2</b>
<b>Acknowledgments</b>	<b>3</b>
<b>Table of Contents</b>	<b>4</b>
<b>List of Figures</b>	<b>6</b>
<b>1 Introduction</b>	<b>8</b>
<b>2 Survey of Existing Linear Actuator Designs</b>	<b>13</b>
2.1 Piezoelectric Linear Actuators	
2.1.1 Piezoelectric Material .....	14
2.1.2 Burleigh Piezo Inchworm Translator .....	15
2.1.3 Philips Components Linear Actuator .....	18
2.1.4 Inchworm Actuator .....	19
2.1.5 Evaluation of Piezoelectric Actuation .....	20
2.2 Magnetostrictive Linear Actuators	
2.1.1 Magnetostrictive Material .....	21
2.1.2 Linearly Operating Motor .....	25
2.1.3 Summary .....	27
<b>3 First Design</b>	<b>28</b>
3.1 Design Concepts	
3.1.1 Jamming .....	28
3.1.2 Toggle Drive .....	32
3.2 Design Overview .....	39
3.3 Component Design	
3.3.1 Jamming Plates .....	39
3.3.2 Toggle Drive .....	41
<b>4 Final Design</b>	<b>45</b>
4.1 Design Concepts .....	45

4.1.1	Jamming Plates .....	45
4.1.2	Wobble Plate .....	46
4.2	Design Overview .....	47
4.3	Component Design .....	49
4.3.1	Jamming Mechanism .....	50
4.3.2	Actuation Mechanism .....	52
<b>5</b>	<b>Prototype</b>	
5.1	Prototype Overview .....	55
5.2	Components .....	57
5.3	Testing .....	60
<b>6</b>	<b>Future Work</b>	<b>63</b>
<b>7</b>	<b>Conclusion</b>	<b>66</b>
<b>8</b>	<b>References</b>	<b>67</b>
	<b>Appendix</b>	
	Prototype Part Drawings	68

## List of Figures

<b>Figure</b>		<b>Page</b>
Figure 1.1	Ford Explorer Seat Drive	8
Figure 1.2	Preliminary Design	10
Figure 1.3	Preliminary Prototype	11
Figure 2.1	Burleigh Piezo Inchworm Translator	15
Figure 2.2	Burleigh Inchworm Motion Schematic	17
Figure 2.3	Philips Component Linear Actuator	18
Figure 2.4	Inchworm Actuator	19
Figure 2.5	Magnetostriction on Molecular Level	22
Figure 2.6	Linear Wave Motor	24
Figure 2.7	Magnetostrictive Wave Actuator	25
Figure 2.8	Linear Operating Motor	26
Figure 3.1	Jamming Phenomenon	29
Figure 3.2	Jamming Plate Orientation	29
Figure 3.3	Preliminary Plate Orientation	30
Figure 3.4	New Plate Orientation	31
Figure 3.5	Jamming Plate Motion Sequence	32
Figure 3.6	Toggle Drive	33
Figure 3.7	Toggle Mechanical Advantage	34
Figure 3.8	Cam Drive	35
Figure 3.9	Toggle Actuation	36
Figure 3.10	First Design Angle View	38
Figure 3.11	First Design Front View	38
Figure 3.12	Jamming Plate Assembly	39
Figure 3.13	Thick Jamming Plate	40
Figure 3.14	Hinge Toggle Drive	41
Figure 3.15	Bolt Assembly	42
Figure 3.16	Flexure Knobs	43

Figure 3.17	Shifting Mechanism	43
Figure 3.18	Cam Prototype	44
Figure 4.1	Jamming Plate Motion Sequence	46
Figure 4.2	Wobble Plate	47
Figure 4.3	Final Design Angle View	48
Figure 4.4	Final Design Front View	49
Figure 4.5	Jamming Plate With Tooth	51
Figure 4.6	Tapered Rubber Sleeve	52
Figure 4.7	Wobble Plate With Tooth	53
Figure 4.8	Wobble Plate Shaft	54
Figure 5.1	Prototype Front View	55
Figure 5.2	Prototype Angle View	56
Figure 5.3	Wobble Plate Assembly	59
Figure 5.4	End Plate	59
Figure 5.5	Wobble Plate Alignment	62
Figure 6.1	New Design Isometric View	63
Figure 6.2	New Design Front View	64
Figure 6.3	Plate Actuation Guide	65

# 1. Introduction

## Problem Definition & Motivation

Seat drives commonly found in top-of-the line automobiles provide at least six degrees of automated motion – fore and aft, up and down and forward and backward tilting. This motion is accomplished through three separate DC permanent magnet motors that drive ball screws via extensive gearing. The current design is both heavy and large, taking up substantial foot space beneath the car seat. (Figure 1.1) A continual goal of the automobile industry is to improve the existing system by designing lighter and more compact seat drives that require fewer components and are less expensive to manufacture.

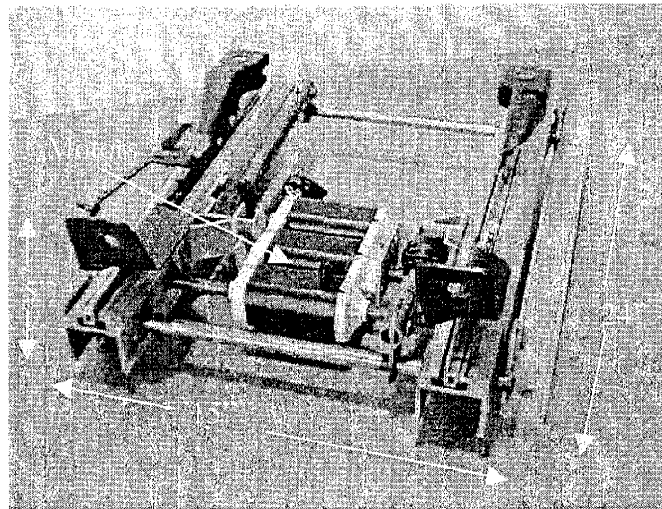

**Figure 1.1**

*Motorized ball screw seat drive found in a Ford Explorer. Three motors are used separately to move the seat fore-aft, up-down and tilt it forward-backward. The design is heavy and large, taking up substantial foot space beneath the car seat.*



## **The Solution Idea**

In searching for novel solutions to create a lighter, more compact seat drive, the idea for a linear, inchworm motion linear actuator was born. The idea was to design a compact linear seat drive that advances the seat by small, continuous step-wise increments.

Existing linear actuators are used in precision measurement and positioning devices but none have been developed for use in automobiles. The invention and application of such a system would be revolutionary to the automobile industry.

The inchworm seat drive is envisioned to be a more economical design, requiring fewer parts making it easier to manufacture. The new seat drive system will be lighter and smaller, freeing up passenger foot space beneath the seat. It would be a modular design that is versatile enough to be implemented across various seat platforms. It would also be designed to meet force, speed and travel range functional requirements.

## **Previous Work**

In the fall of 2000, a preliminary inchworm actuator was designed and built for the Lear Corporation under the guidance of Professor Ernesto Blanco. (See Figure 1.2) The actuator design was conceptually simple and succeeded in moving the actuation system along the shaft in step-wise increments. The main components of the system included jamming plates, a shaft, brackets, tension springs and solenoids. The jamming plates were used to alternately lock and unlock on the shaft. The solenoids advanced the solenoid-jamming plate system on the shaft by altering the locking geometry of the plates as well as the relative distance between the plates.

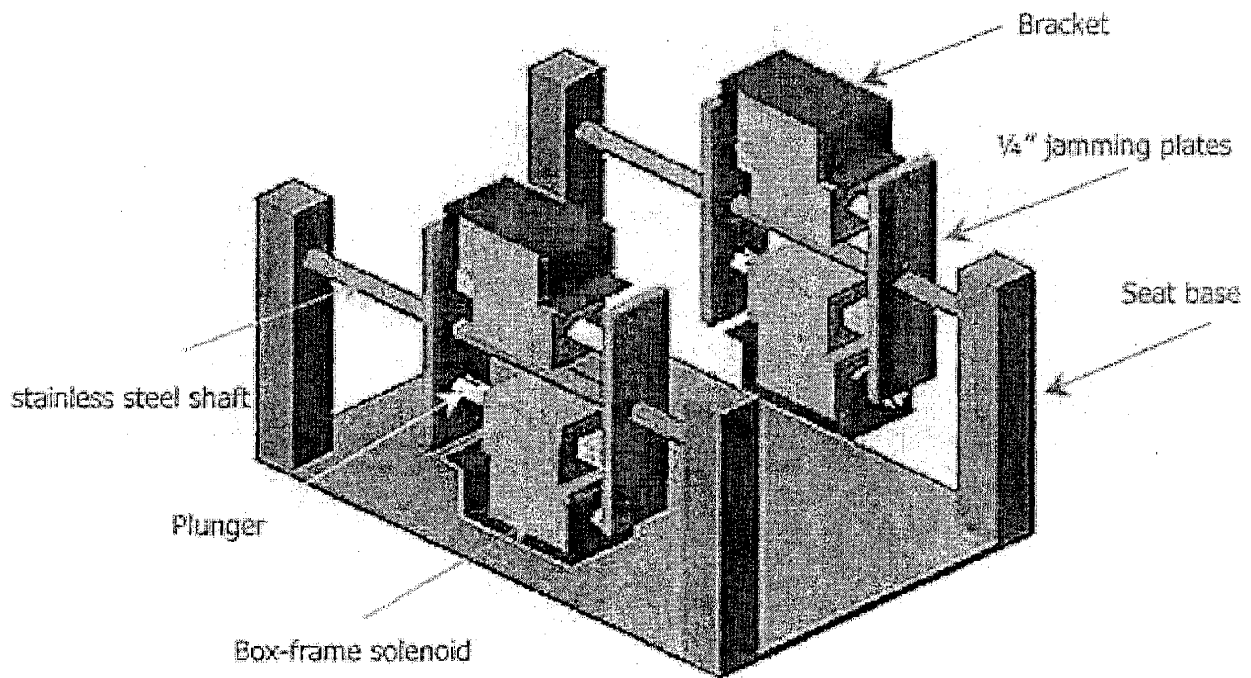
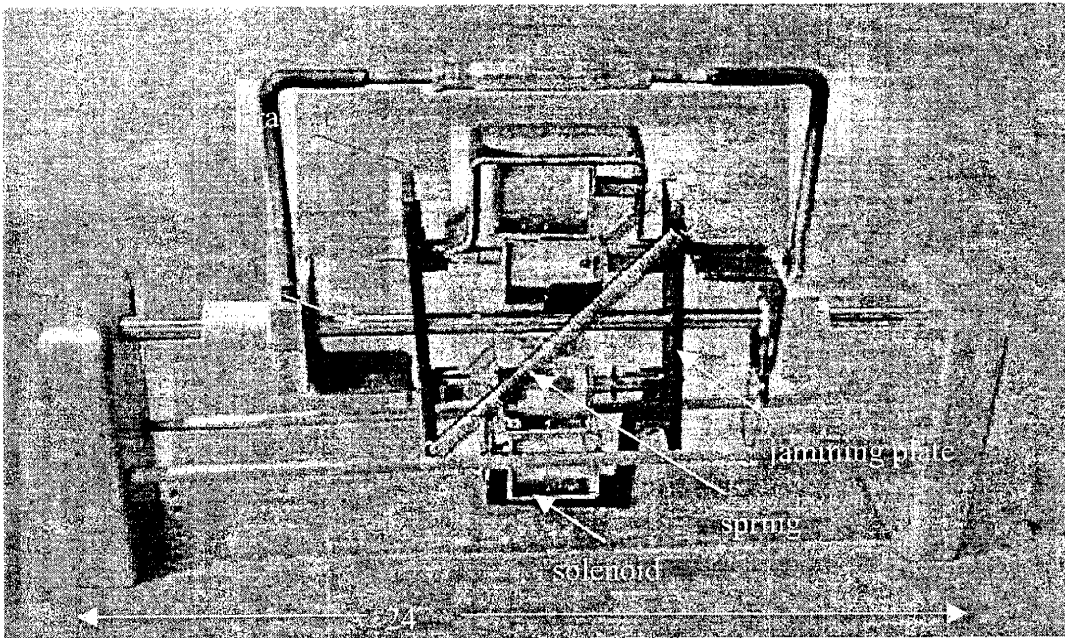

**Figure 1.2**

*Solid model of an inchworm linear seat drive designed at MIT for the Lear Corporation. The seat drive uses solenoids to sequentially lock and unlock jamming plates, simulating inchworm motion along a steel shaft. Emergency locking is provided via the locking plates.*

Although the prototype was capable of reliably inching along the shaft, it demonstrated several undesirable qualities. (Figure 1.3) First is the issue of actuator selection. The use of solenoids as actuators is undesirable due to their high electrical current requirements and in general, their use is avoided in the automobile industry. The total number of solenoids used to provide fore/aft motion is eight, four pull-solenoids on each side of the seat drive. This is a substantial increase from the one motor that is normally used to provide the same motion thus making it economically unfeasible.

Second, the prototype did not demonstrate smooth and quiet motion. The lack of a smooth, continual stepping motion can be contributed to the non-optimal geometry of the jamming plates, lack of proper alignment and the absence of a motion sequence generator for the solenoids. The noise from the jamming plates and the solenoids were not damped, making the operation loud and seemingly clumsy. The large size of the model made it not very attractive for automobile use.



**Figure 1.3**

*Preliminary prototype of inchworm linear seat drive. The system succeeded in providing inchworm motion but the awkward size and geometry made it unappealing.*

## **New Design Solution**

Having learned from the preliminary design, improvement ideas quickly arose. A new design would eliminate the use of solenoids, using instead smaller, quieter actuators. The design prototype would be smaller (reflecting more accurately its geometry beneath a car seat) and machined more precisely, allowing for better alignment and reduced friction. The objective is therefore to improve upon the previous design by incorporating the established jamming mechanism into a neater, smaller package that meets all the functional requirements of a seat drive.

## **Paper Organization**

The first phase of this inchworm project begins with an extensive literature and patent search on existing linear actuators and inchworm devices. Both piezoelectric and magnetostrictive inchworm actuators will be examined and their components evaluated for possible use in the linear inchworm drive.

The next section of the report will discuss the final design, beginning with an explanation of the principle concepts that govern the design of the two main modules. A detailed explanation of the mechanisms and their components will be presented.

Following the presentation of the final design idea is the presentation and analysis of the prototype. Finally, in the conclusion and recommendation section, suggested improvements in future work and alternative embodiments will be presented.

## **2. Survey of Existing Linear Actuator Designs**

In an effort to understand the existing technology behind inchworm actuation and to generate ideas for the design of a new actuator, an investigation was conducted on existing inchworm technology. Combing through the massive pool of existing designs, four inchworm actuator patents were selected for closer study. The four designs, intended for use in nan positioning devices, are actuated by either piezoelectric or magnetostrictive materials. Piezoelectrics and magnetostrictives are considered to be ‘the future’ of precision positioning devices. Their unique physical qualities allow for the design of simple, small actuators.

### **2.1 Piezoelectric Linear Actuators**

Piezoelectricity is the property by which a material reacts to an applied electric voltage by changing shape and vice versa, generating an electric current in response to an applied mechanical stress. Piezoelectric actuation was the first alternative to be considered as replacement for the solenoids which were used in the preliminary inchworm prototype. To better understand the feasibility of using piezoelectric materials in seat drives, research was done on their material properties.

### 2.1.1 Piezoelectric Material

Piezoelectrics, also known as piezoceramics, are used to either transfer electrical energy into mechanical energy or mechanical energy into electrical energy. They are often used in precision positioning devices as both actuators and sensors. The mechanical force response of piezoelectrics to an applied voltage is dependent upon the piezoelectric properties of the ceramic, the geometry of the piece and the direction of excitation. Piezoelectrics respond only with microscopic dimensional changes, but when multi-layered, macroscopic motions can be produced.

The phenomena of piezoelectricity can be attributed to the material's cell-like atomic structure. Contained within the piezoelectric cells are atoms and a single semi-mobile ion which can exist in several stable quantum states. The position of the ion can be changed by either physically deforming the cage or by applying an electrical field to the cell; this phenomenon results in the geometric – electrical coupling found in piezoelectrics.

Used in linear and rotary actuators, piezoelectrics allow for simple, highly dynamic designs that can achieve high force-density and that provide noiseless operation and high holding forces. However, the disadvantages of piezoelectrics include their high cost and undesirable material properties such as hysteresis creep, brittleness and temperature sensitivity.

In the design of piezoelectric linear actuators, piezoelectric stacks are arranged to produce inchworm motion by alternating clamping and translation. Presented in the

following section are three different piezo linear inchworm actuators, one patented by Burleigh Instruments, another by Philips Components and a third which operates in a manner very similar to the Philips actuator. Both patented designs are used in nano-positioning devices.

### 2.1.2 Burleigh Piezo Inchworm Translator

The Burleigh Piezo inchworm translator is among one of the earliest piezoelectric inchworm actuators to be developed. Its design intent was to provide an electromechanical translation device that allows for fine resolution stepwise motion over long distances under high loads. Shown on the following page is a cross sectional view of the actuator. The piezoceramic strips (29, 31 and 32) are wrapped around the shaft (24) and act as extending and clamping members.

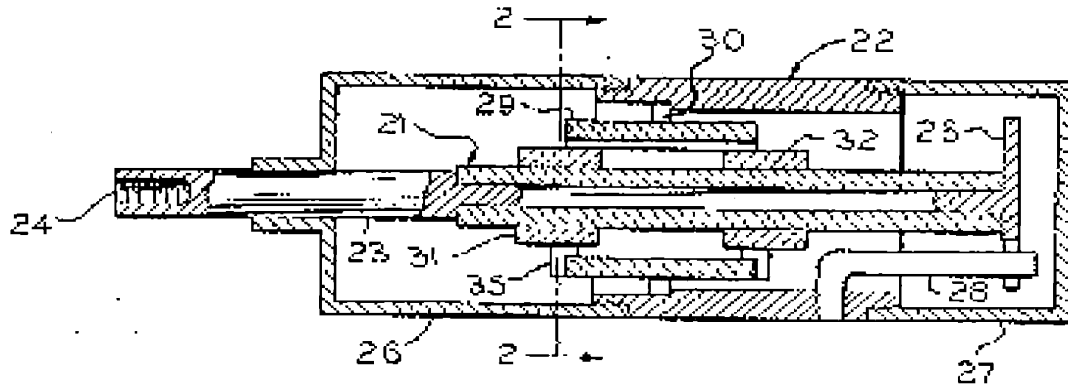

**Fig. 2.1**

*Cross section of the Burleigh Piezo Inchworm Translator. The translator operates by virtue of piezoelectric clamps (31 and 32) and a central actuator (30).*

<sup>1</sup> US Patent 4,570,096

The basic concept behind the actuator is demonstrated in the schematic diagram on the next page illustrates the sequence of operation. (Figure 2.1) The clamping actuators represent members 31 and 32 in the Burleigh translator and the central actuator represent piezoelectric member 30.

In step 1, the system is “off” and none of the piezoelectrics are engaged. Starting with step 2, the inchworm engages by locking onto the shaft with the left clamp. The central actuator extends, pushing the left clamp with the locked shaft in the left direction.

Afterwards, the right clamp engages (step 4) and the left one opens (step 5). When the central actuator contracts (step6), the shaft inches left a bit more. The seven step sequence repeats again after the left clamp locks and the right clamp opens.



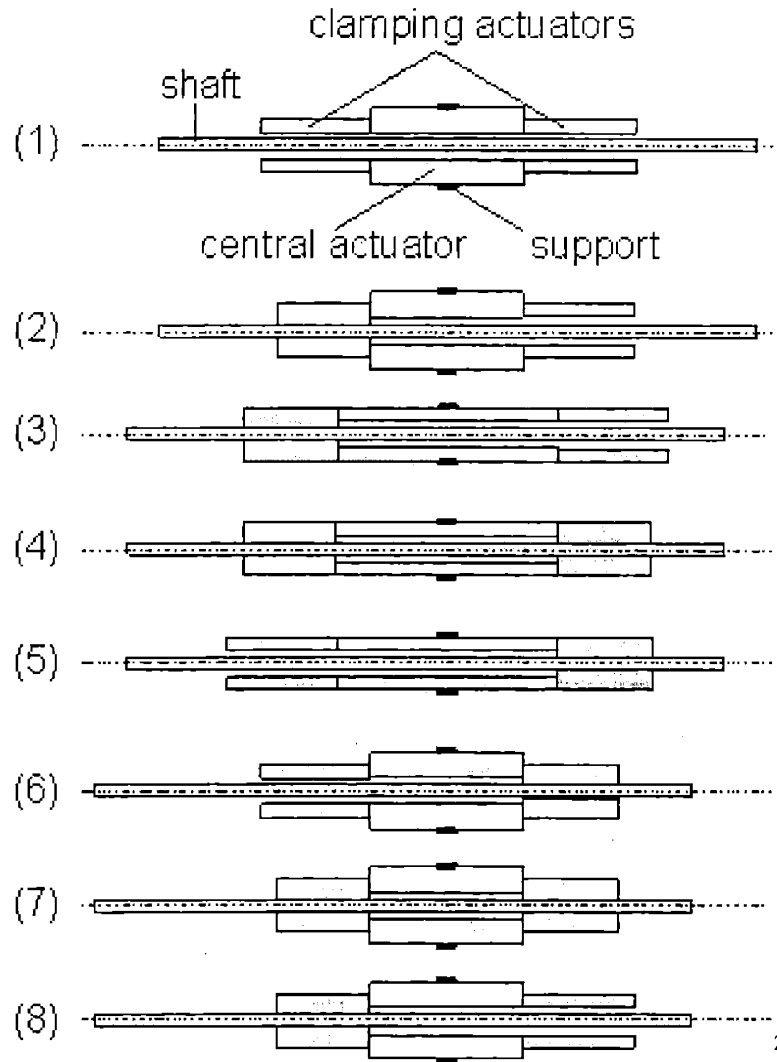

**Figure 2.2**

*Schematic diagram of the step-wise motion of the Burleigh inchworm translator. The shaft is moved to the left by alternating clamping and extending motions of the piezoelectric actuators.*

The inchworm translator has a very simple design that uses only piezoelectric actuation. Depending upon the electrical input sequence, the shaft may be moved in either direction at variable speeds. Its small size and symmetry are qualities that should be adopted in a

<sup>2</sup> <http://www.ktu.lt/tsc/en/science/nauji/ss04.html>

seat drive design. However, its lack of a self-locking state (in the absence of power) is undesirable.

### 2.1.3 Philips Components Linear Actuator

A more complex linear actuation device is one designed by Philips Components (Figure 2.3). This motor uses stacked piezoelectric elements for actuation and clamps with the aid of flexures. The use of flexure clamps allows for large clamping forces. The stacked piezoelectrics also allow for large motions and forces. The actuator's sequence of operation is similar to that of the Burleigh translator, with clamps that alternate locking and unlocking and a central actuator that extends and contracts.

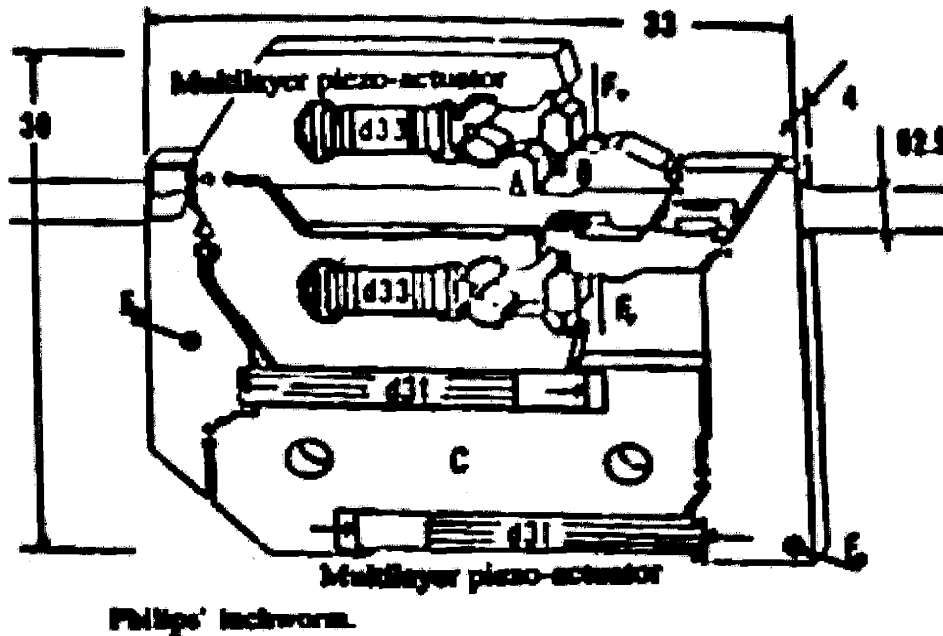
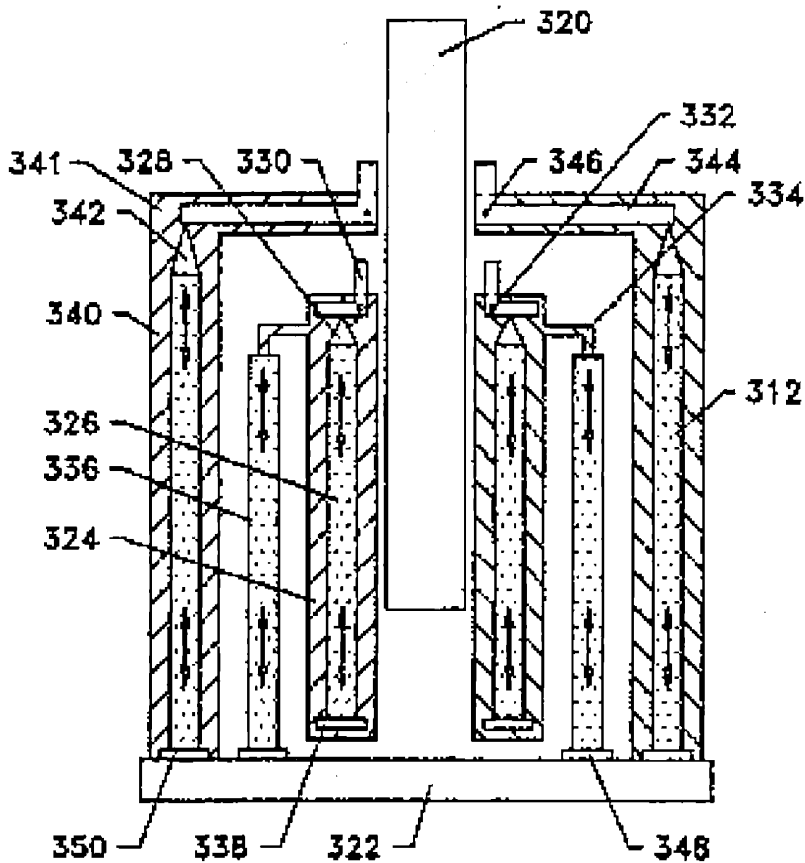

Figure 2.3

*The Philips Component linear actuator uses piezoelectric stacks to provide inchworm motion. The stacks actuate a complex series of flexure guided clamps that lock onto the shaft, shifting its position.*

### 2.1.4 Inchworm Actuator

A third inchworm linear actuator that was studied is shown below. (Figure 2.4) This actuator uses piezoelectric stacks (312, 326, 336) in combination with flexure clamps to move a centrally located shaft (320). The piezoelectric stacks serve as driver stacks that engage and disengage the clamps. Similar to the Philips linear actuator, the piezoelectric drivers move parallel to the driven shaft.



3

**Figure 2.4**

*In the inchworm actuator, piezoelectric stacks actuate a series of clamps which clamp onto the shaft, shifting it up or down.*

<sup>3</sup> US Patent 05332942

The motions of the shaft are small because the piezoelectric stroke length is only a few tenths of a percent of the length of the driver. The use of clamps decreases the amount of useful driving stroke length as part of the stroke is used to move the clamps. In spite of the short stroke length, the shaft can be driven at a rate of about 1.5 cm/s when the piezoelectric stacks are actuated in a rapid sequence.

### **21.5 Evaluation of Piezoelectric Actuation**

An evaluation of piezoelectric actuation leads to the conclusion that the use of piezoelectrics in car seat drives is unfeasible due to high cost and material brittleness. Benefits from this investigation include the generation of concept ideas which may be incorporated in the final design -- ideas such as flexure hinged clamps and spring loaded clamps.

## 2.2 Magnetostrictive Linear Actuators

### 2.2.1 Magnetostrictive Material

Magnetostriction is the phenomenon in which magnetic energy is transferred into mechanical energy or vice versa when mechanical energy is transferred into magnetic energy. In the first case, known as the Joule effect, magnetostrictive materials change shape in response to a changing magnetic field. Joule effect is utilized mainly in the design of actuators where motion or force is the desired outcome. The opposite case, the Villari effect, is when geometric distortion brings about a change in the material's magnetic state. And this effect is used mainly in the design of sensors for detecting motion and force. As most devices couple electric and magnetic energy (for example, using electric currents to generate magnetic fields in induction coils and generating current electric current with changing magnetic field) magnetostrictive actuators are really electro-magneto-mechanical devices and not solely magneto-mechanical.

The physics behind magnetostriction is best described using a simple diagram. In Figure 2.5, ovals represent the magnetic domains that make up the molecular structure of magnetostrictive materials. When no magnetic field is applied ( $H=0$ ) the domains are disorganized. Upon exposure to a magnetic field  $H$ , the domains rotate, aligning along the magnetic field lines.

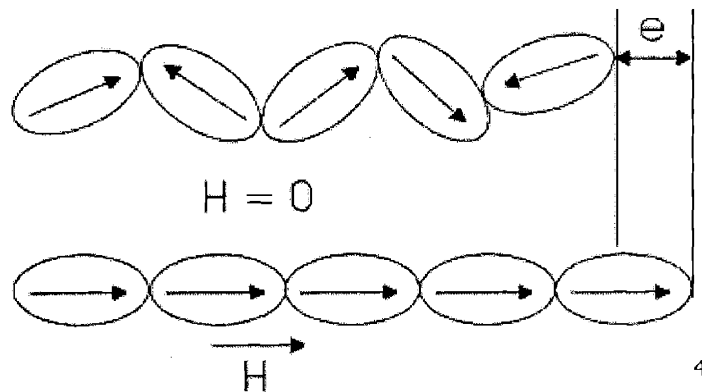

**Figure 2.5**

*On the molecular level, magnetostrictive materials are comprised of magnetic domains that orient themselves along magnetic field lines. When not exposed to an external magnetic field,  $H=0$ , the domains are disorganized. As soon as a magnetic field,  $H$ , is applied, the domains rotate and align along field lines, causing a geometric distortion ( $e$ , on the macroscopic scale).*

The reorientation of the molecular domains causes geometric distortion on the macroscopic level, elongating the material along the direction of the field. As the field gets stronger, more domains get aligned and greater elongation is achieved. In this process, volume is conserved.

The use of magnetostrictive materials is becoming more and more widespread.

Magnetostriction is used in devices such as high force linear actuators, positioners for optic equipment, active noise control systems, and ultrasonic cleaners and pumps.

Although there are many benefits to using magnetostriction, there are also drawbacks.

---

4

<http://aml.seas.ucla.edu/index/MGSTR/Magnetostriction%20and%20Magnetostrictive%20Materials.htm>

The key limiting factor for increased use of magnetostrictive alloys is high cost.

Terfenol-D, like other magnetostrictive alloys, is made from expensive rare earth elements. However, over the years, due to increased supply and demand, the cost of such alloys have decreased dramatically. If the trend continues, there is reason to expect their use in high-end car seat drives.

Recent efforts to design simple, reliable linear actuators using magnetostrictive materials can be seen at ETREMA Products Inc, in Ames, Iowa. The basic idea is to insert a rod of Terfenol-D into a metal cylinder whose inner diameter is slightly smaller than the rod diameter. Wrapped around the cylinder are electromagnetic induction coils that generate a moving magnetic field. The traveling magnetic field causes the Terfenol-D rod to move along with it; sections of the rod that are exposed to the magnetic field elongate and in the absence of the field, contract. The wavelike motion induced by the traveling magnetic wave causes the Terfenol-D rod to inch along the cylinder and the resulting motion can then be harvested to do work.

### Example- Linear Wave Motor

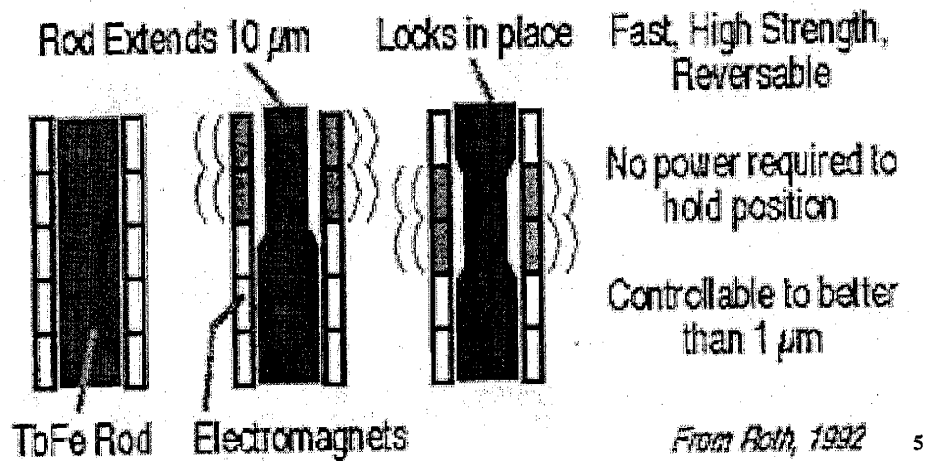

Figure 2.6

*The main components of a magnetostrictive linear wave motor are a magnetostrictive rod and a metal cylindrical housing around which induction coils are wound. The rod inches up and down by “stretching” and pushing against the sides of the cylinder.*

There are many benefits to using magnetostrictive actuators of this type. The actuator is self-locking, fast, strong, requires few parts, runs on low voltages, has a high work output per unit mass and does not require high maintenance. Moreover, one can obtain very high precision, with magnetostrictive linear actuators of this kind (down to one micrometer).

<sup>5</sup> <http://www.nanocentral.com>



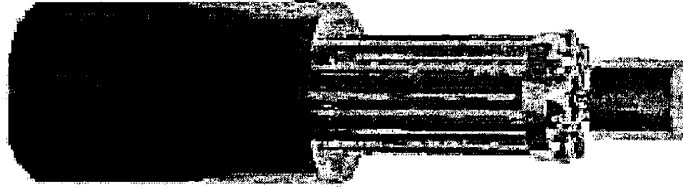

6

**Figure 2.7**

*Example of a magnetostrictive wave actuator. Magnetostrictive wave actuators are fast, simple and compact.*

### **2.1.2 Linearly Operating Motor**

A magnetostrictive inchworm motor that is of particular interest to this design project is the Linearly Operating Motor (Figure 2.8). The unique aspect about this motor is that it makes use of jamming, rather than clamping to realize inchworm motion. A closer study of the mechanism allows for a better understanding of the linear motion sequence.

The main components of the design are an actuation element that elongates and contracts, a driven shaft, and alternating locking and unlocking members.

---

<sup>6</sup> <http://www.public.iastate.edu/~terfenol/homepage.html>

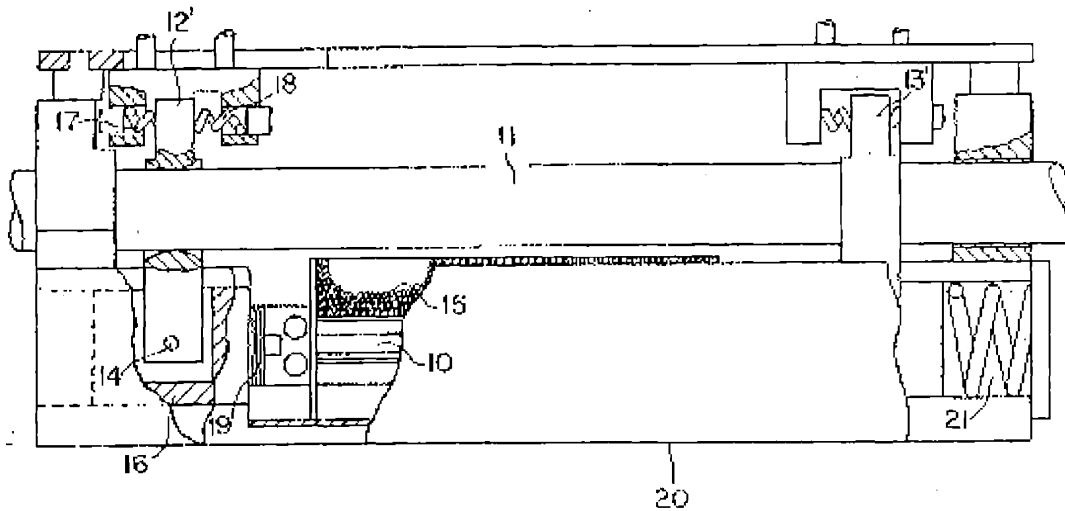

**Figure 2.8**

*Linearly operating motor. This motor makes use of magnetostrictive actuation to engage and disengage jamming plates. What makes this design unique from those of the piezoelectric actuators is its use of jamming, rather than clamping to lock and move the shaft.*

In the embodiment shown above, member 10 is the magnetostrictive element that provides linear motion to the system. Members 12 and 13 are spring-loaded locking members and member 11 is the shaft. The way the motor works is that the magnetostrictive rod expands, tilting and jamming the locking collar 12 against the shaft. As the rod expands more, collar 12 pulls the shaft to the left. At the moment when 12 is jammed, locking collar 13 is open, allowing the shaft to slide freely to the left. At the end of its expansion stroke, the magnetostrictive rod contracts, opening 12 and locking 13 by virtue of pretension spring 21. Contracting more, the rod pulls the open collar 12 to the right, with the shaft remaining stationary. With this one expansion/contraction cycle, the shaft has inched left.

<sup>7</sup> US Patent 5013945

The strength of the linear operating motor design lies in its simplicity. The small number of moving parts and the linearity of the design makes it practical for use in a small space such as beneath a car seat. The self-locking mechanism makes it attractive for implementation in terms of car safety. However, there are two major drawbacks to the design: the high cost of the magnetostrictive rod and the absence of a method to reverse shaft motion from left to right.

### **2.1.3 Summary**

All the linear motors discussed can be actuated using either piezoelectrics or magnetostrictive materials. The choice of actuation depends on the specific requirements of the system. Although both piezoelectric and magnetostrictive linear actuators were deemed unfeasible for use in a car due to high cost, this study resulted in the generation of many design ideas for a less expensive actuation mechanism.

## 3. First Design

### 3.1 Design Concepts

As evidenced from existing linear actuators, inchworm motion can be achieved using two basic components: clamping and length changing elements. In designing the clamping component, the original idea of using jamming plates was pursued. Jamming plates were chosen because they are a low cost and mechanically simple design solution to clamping; they also require minimal actuation. As for the length-changing component, a simple wobble plate was used to transfer rotational power from a motor to translational motion.

#### 3.1.1 Jamming

The jamming principle, as applied to sliding elements, occurs when additional degrees of freedom are introduced into what is intended to be a single degree of freedom motion.

Figure 3.1 demonstrates the condition under which jamming between a sliding element and shaft will occur.

In Figure 3.1a, the thin plate is a good candidate for jamming. The small thickness to diameter ratio ( $T:D$ ) makes it easy for the plate to tilt and jam against the shaft with its sharp edge. The rule of thumb for a smooth sliding action is to have  $T:D$  be greater than 2 (assuming that the bore clearance of the sliding element is small). This is demonstrated in Figure 3.1 b, where  $T:D$  is greater than 2, allowing for smooth sliding.

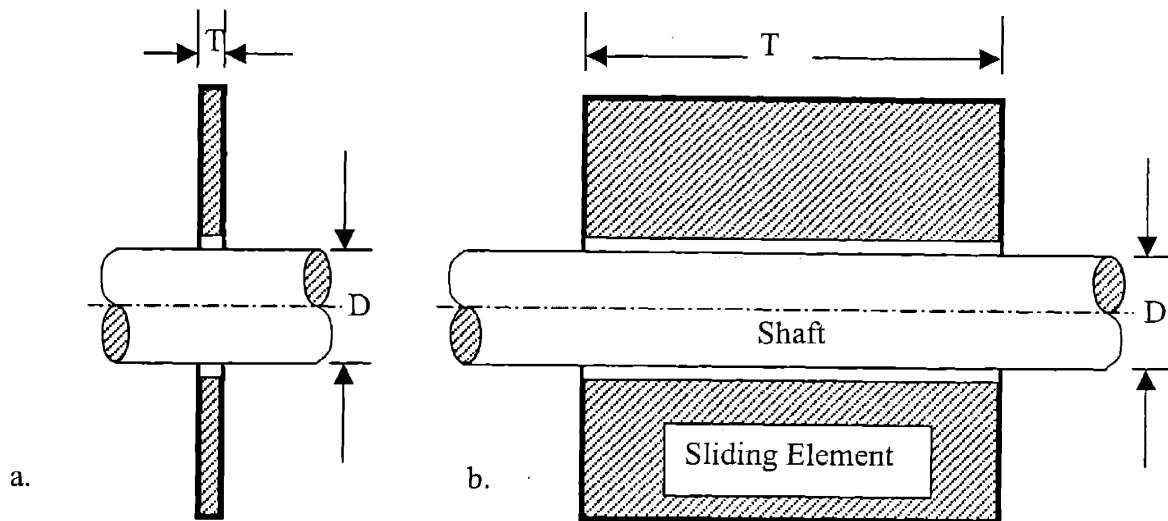

**Figure 3.1**

*Jamming would occur in the shaft-sliding element arrangement on the left due to the small thickness to diameter ratio ( $T:D$ ). The large  $T:D$  ratio of the arrangement on the right prevents jamming.*

When using two jamming plates against a shaft, there exists infinite possible plate - plate orientations. If both plates are to be aligned such that the point of jamming occurs on the same plane, the plates can either be tilted in the same direction (parallel) or away from each other in a “v” shape. (Figure 3.2 )

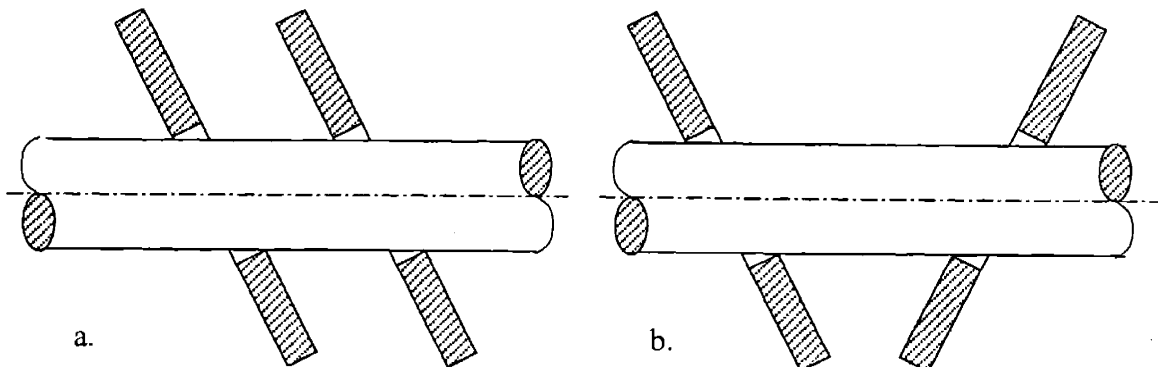

**Figure 3. 2**

*The orientation of the jamming plates can either tilted in the same direction (a) or in the opposite direction (b).*

In the preliminary inchworm design, the plates are spring-loaded to tilt in the same direction. (Figure 3.3) The tension spring connecting the two plates maintain the plates' orientation. An expanding and contracting element (solenoid) at the top and the bottom of the plates open and lock the plates in order to move the shaft.

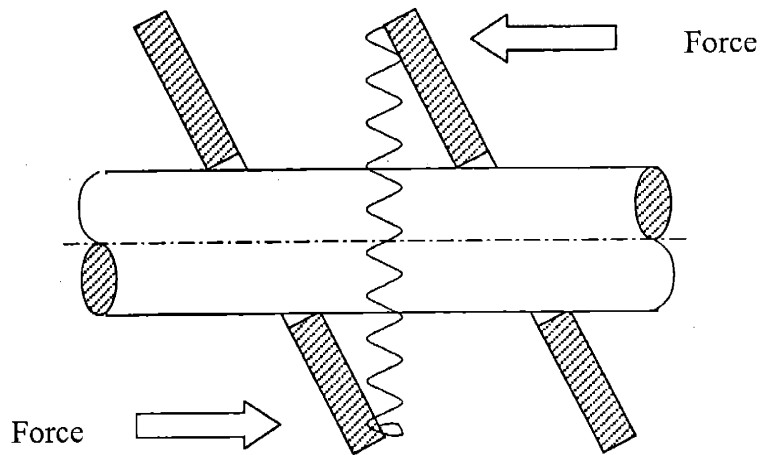

**Figure 3.3**

*In the preliminary inchworm design, jamming plates are oriented parallel to each other. A tension spring located between the plates maintain the plates' orientation. The arrows represent the force applied by the springs to the plates.*

In the new design, the plates are oriented to tilt away from each other. (Figure 3.4) A compressive force is applied at the bottom of plates, pushing them together at the bottom and tilting them apart at the top in the shape of a "v."

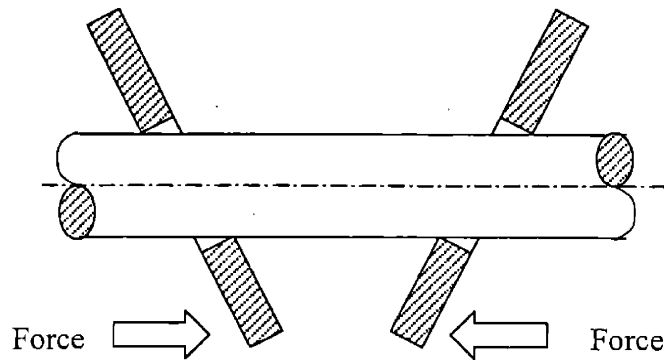

**Figure 3.4**

*In the new design a spring force is applied at the bottom of the plates such that the plates would tilt in a “v” geometry.*

The design of the toggle inchworm system was based on the motion sequence envisioned below. (Figure 3.5) The sequence is comprised of six discrete steps which begins in a “power off” locked position. The right plate acts as the shaft driver while the left plate simply locks and unlocks on the shaft. By locking and pulling on the shaft, the right plate advances the shaft to the right. The shaft can also be advanced in the leftward direction simply by changing their respective locking sequence.

Left Plate      Right Plate

1. LOCKED	LOCKED
2. OPEN	LOCKED
3. OPEN	LOCKED & SHIFTS
4. LOCKED	OPEN
5. LOCKED	OPEN & SHIFTS BACK
6. LOCKED	LOCKED

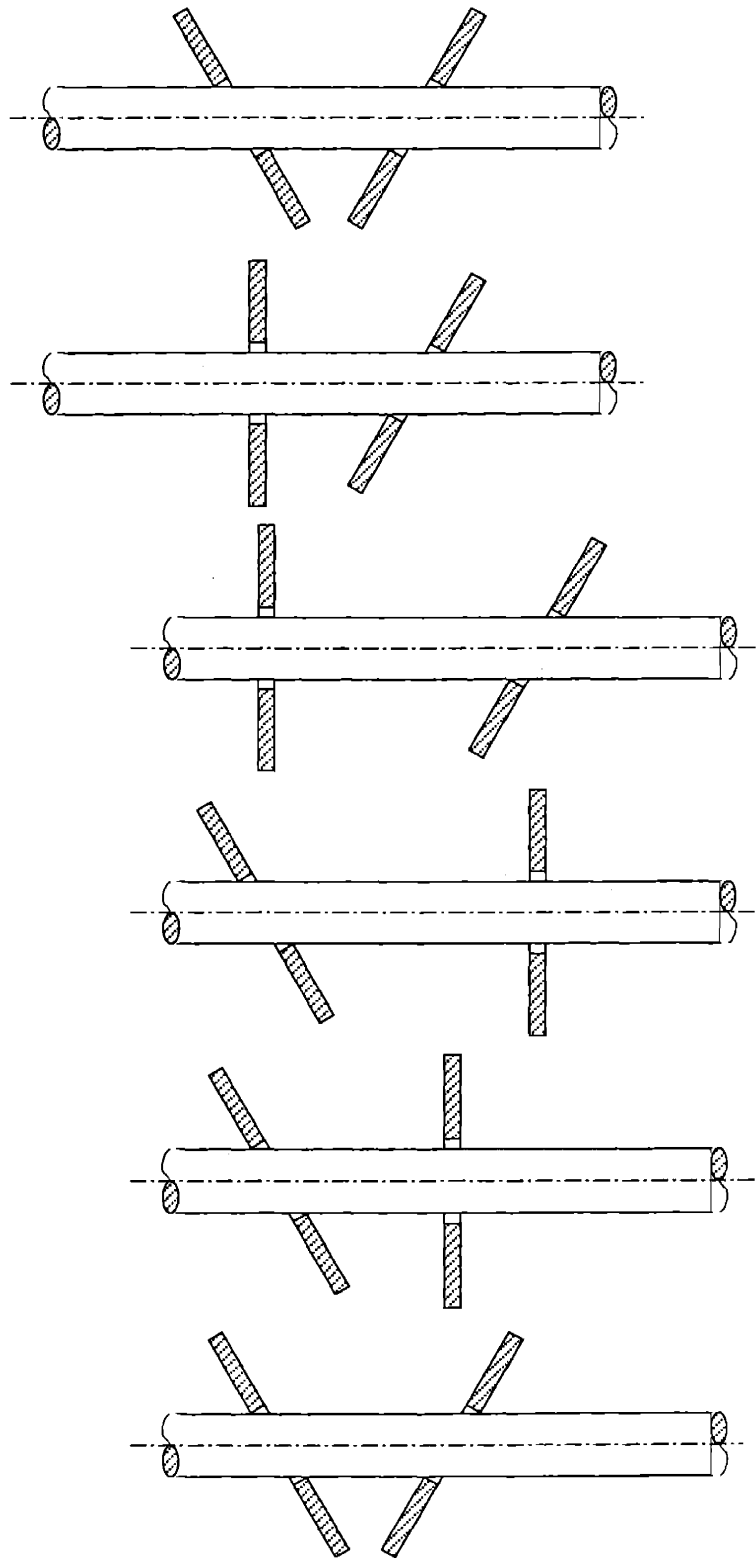

**Figure 3.5**

*Motion sequence for advancing the shaft in the right hand direction. Leftward advancement may be attained by reversing the roles of the plates.*



### 3.1.2 Toggle Drive

In searching for an actuation mechanism that would provide linear extension and contraction, the toggle drive was chosen. When force is applied to the top of the toggle, the resultant force exerted by the legs on the contact surface has both vertical and horizontal components. The horizontal force component acts to push the plates away and the restoring force pulls the plates back together (extension and contraction). (Figure 3.6)

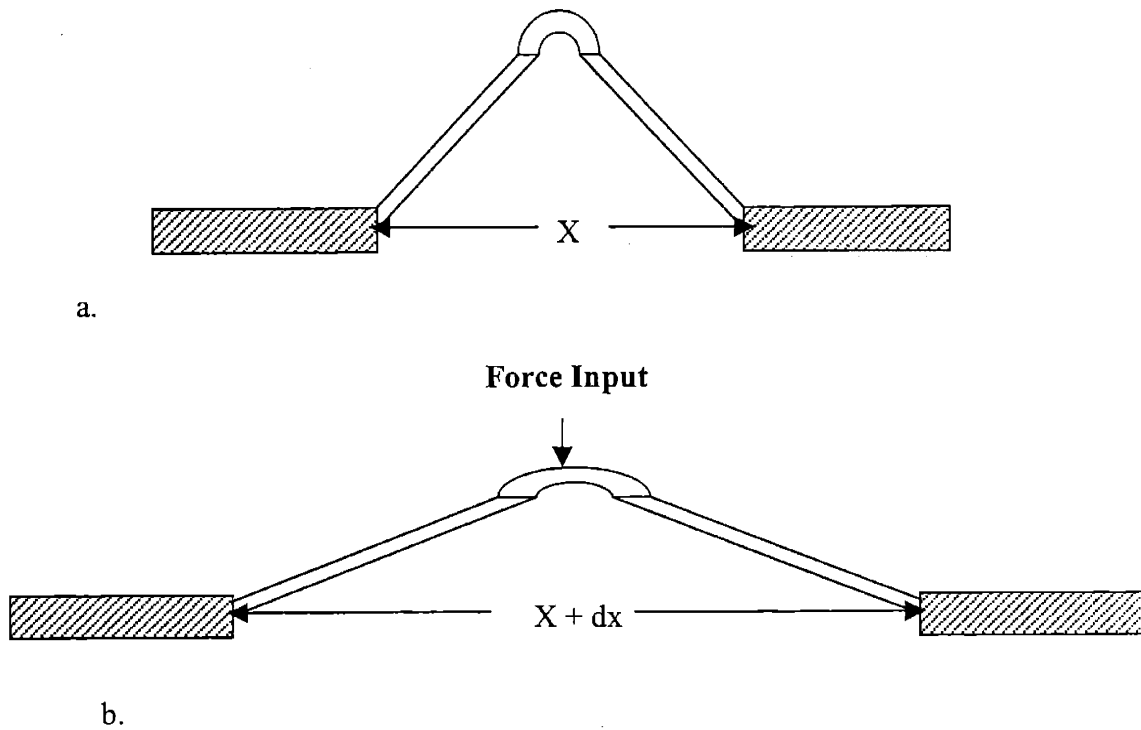
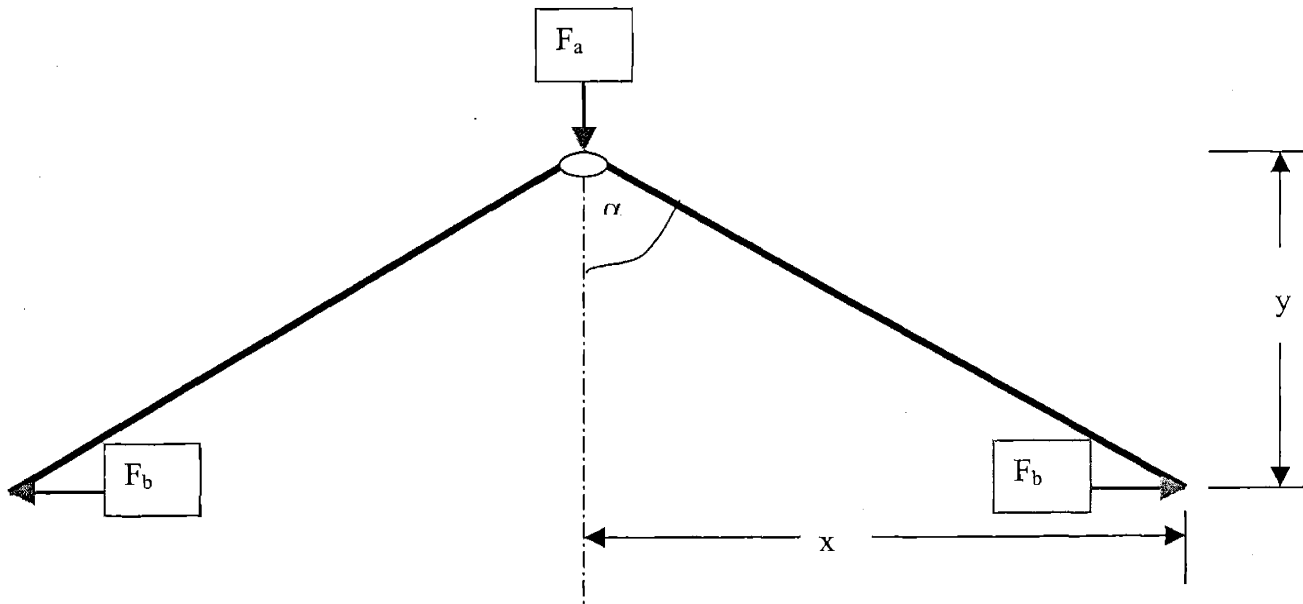

**Figure 3. 6**

*In the no-load state, the toggle is contracted. When a force is applied at the top of the toggle, the legs of the toggle “flatten out,” pushing apart the two plates.*

The mechanical work advantage of the toggle drive is large; ideally, it reaches infinity at the point where the toggle legs straighten out. In Figure 3.7, the two dark lines represent the legs of the toggle drive.  $F_a$  is the applied load and  $F_b$  is the horizontal resultant force.

As angle  $\alpha$  increases to  $\pi/4$  and the legs straighten out, the mechanical advantage,  $F_b/F_a$ , approaches infinity.



$$\text{Mechanical Advantage} = F_b/F_a = \frac{1}{2} x/y = \frac{1}{2} \tan \alpha$$

**Figure 3.7**

*Ideally, neglecting friction and material resistance, the mechanical advantage of a toggle drive is very high, reaching infinity at the point where  $\alpha = \pi/4$*

To actuate the toggle, a vertical force,  $F_a$  is needed. As a simple way to provide this force is a motorized cam. Using a cam, the torque from the motor is translated into a vertical force which is then applied at the toggle vertex. (Figure 3.8) With every full rotation, the vertex of the toggle plate would be displaced a height of  $r_2 - r_1$  (where  $r_1$  is the smallest effective radius and  $r_2$  is the largest). The compression spring shown in the diagram is used to keep the toggle vertex in contact with the cam, restoring the toggle back to its upright position when the cam is engaged along its shortest radius.

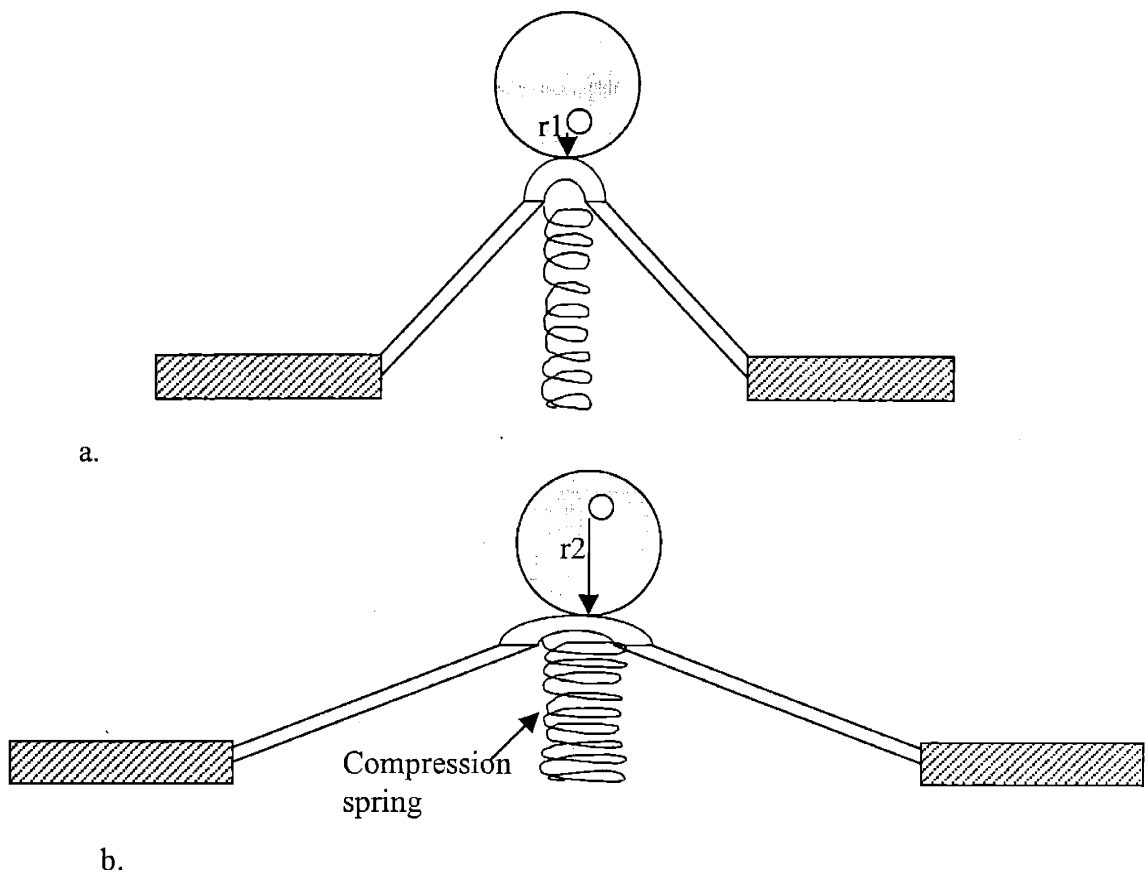

**Figure 3.8**

*A cam can be used to actuate the toggle drive. The different effective radii of the cam allow for a vertical displacement of  $r_2 - r_1$  with every full rotation.*

The toggle drive is envisioned to work in conjunction with the plates as shown in Figure 3.9. The sequence of motions in Figure 3.9 is identical to the sequence in Figure 3.5 except steps 2 & 3 and steps 4 & 5 have been combined as one locking and shifting step. The arrows indicate the toggle legs and the direction of applied force. When no force is applied and the mechanism is in the “off position,” the arrow head is a circle. The jamming plates are pivoted and tension springs maintain the plates in the locked position. When the palates unlock, the base acts as a stop to limit the tilt of the open plate. The location of the toggle leg – jamming plate contact point is critical because shifting its position would change the kinematics of the system.

Left Plate    Right Plate

1.

Locked    Locked

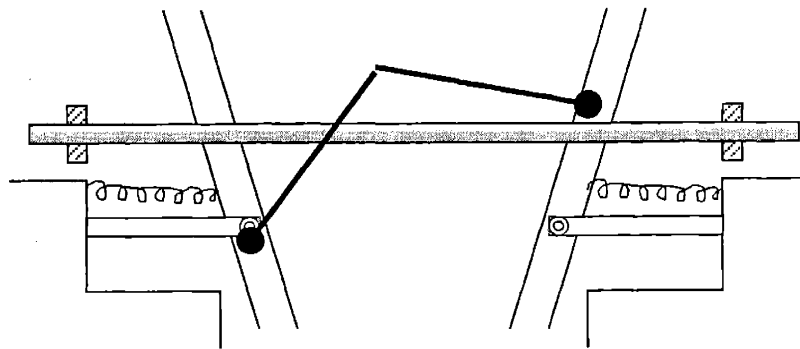

2.

Open    Locked & shifts

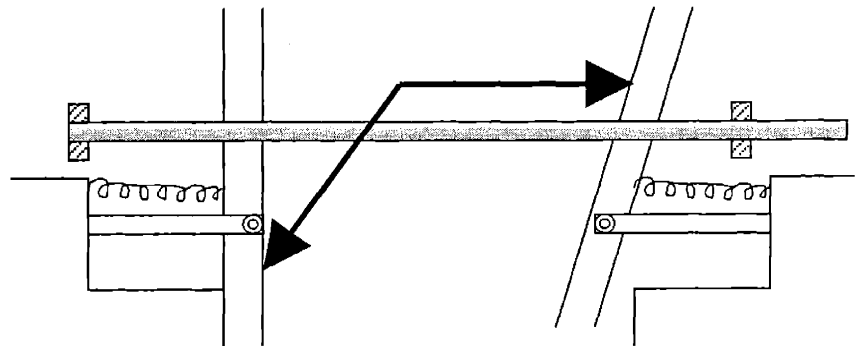

3.

Locked    Open & shifts

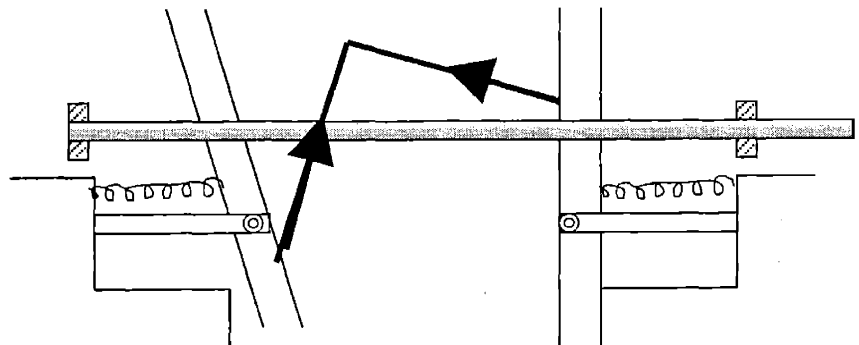

4.

Locked    Locked

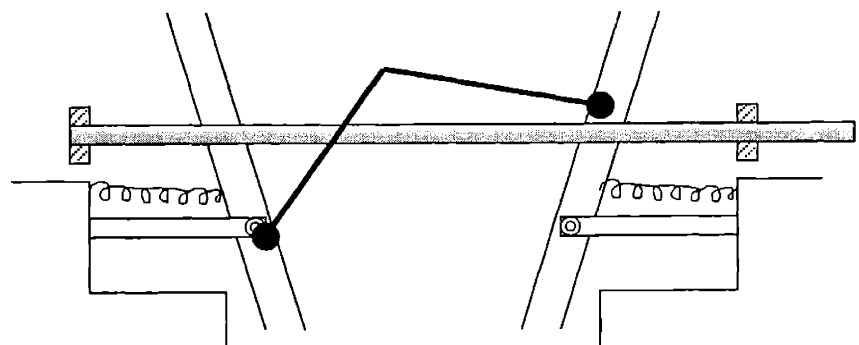

**Figure 3. 9**

*Sequence of motions for the toggle actuated jamming plates.*

### 3.2 Design Overview

Armed with the idea of using a cam driven toggle and jamming plates to build an inchworm actuator, a preliminary design was created. (Figure 3.10) This is a complicated design that consists of over 25 parts. The toggle drive is driven by a motorized cam which sits at the top of the mechanism. The gear shown in the solid model is connected to a motor not shown in the figure. Depending on the direction of cam rotation, the toggle drive switches to actuate at different positions on the jamming plates. When the cam changes direction, a key on the cam rotates the orientation of the toggle drive, switching the position of engagement on either plate. The toggle legs glide along the grooves of the jamming plate, locking into either of the two stable positions (either on the top or at the bottom of the jamming plates).

#### Parts:

2 toggle legs	4 spring bolt assemblies
2 jamming plates	4 jamming plate springs (not shown in solid model)
1 toggle guide	2 guide springs (not shown in solid model)
1 guide shaft	1 cam
1 cam shaft	1 geared motor
1 shaft	1 base
4 pivot pins	

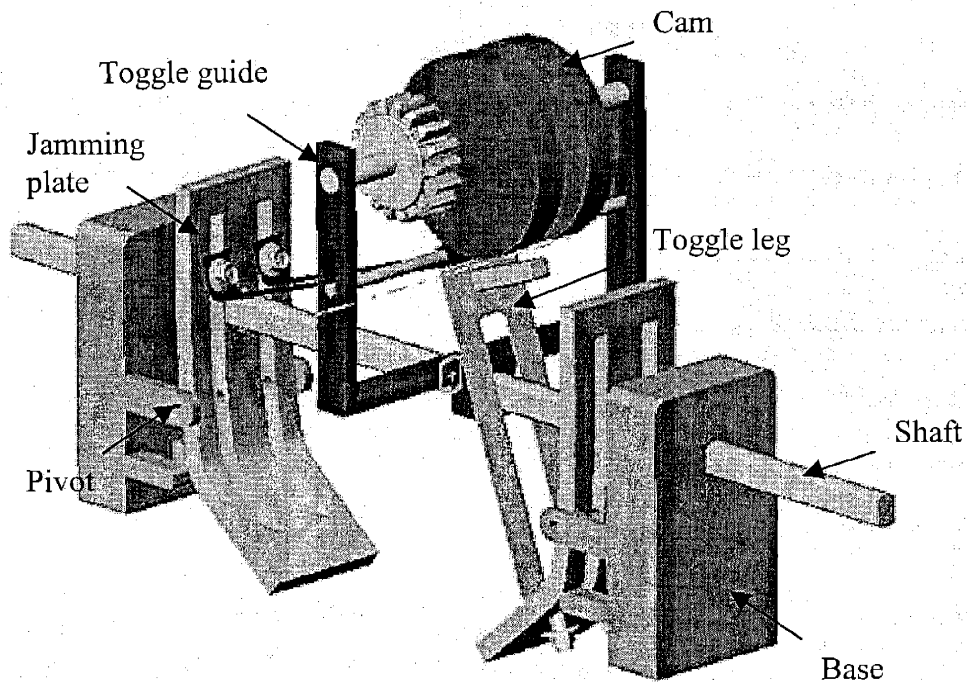

**Figure 3.10**

*Angle view of the first actuator design. This complicated looking mechanism consists of over 25 parts and uses a cam-toggle drive.*

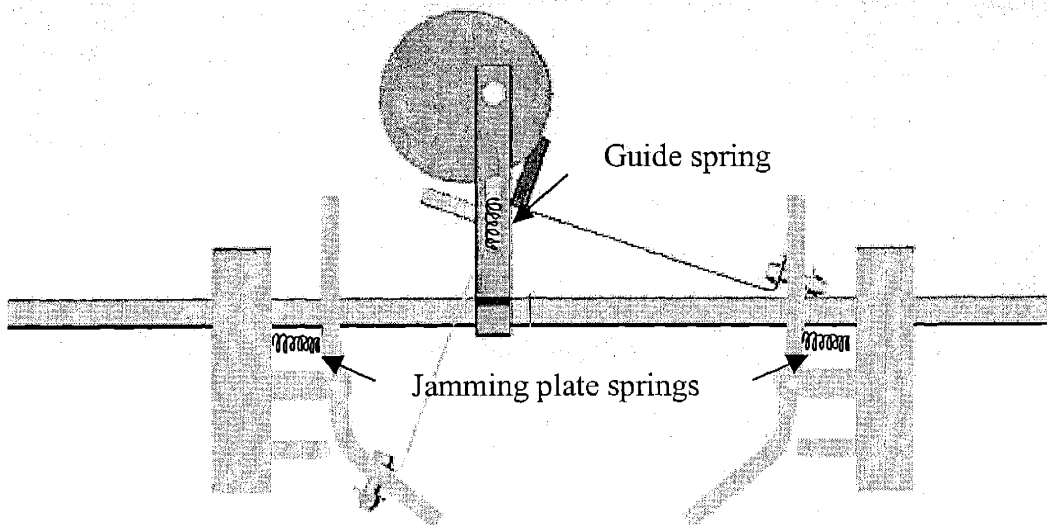

**Figure 3.11**

*Front view of the first inchworm actuator design. This view more clearly shows the alignment of parts and the bent geometry of the jamming plates.*

Figure 3.11 shows more clearly the bent geometry of jamming plates and the orientation of the toggle legs. The compression guide spring keeps the toggle vertex in contact with the cam. The jamming plate tension springs maintain the plates' "v" orientation when the system is not powered.

### 3.3 Component Design

#### 3.3.1 Jamming Plates

The jamming plate geometry is designed to allow for the easy sliding of the toggle legs up and down the plate. It is designed such that there are only two stable positions for the toggle legs – one position at the top of the plate and another at the bottom.

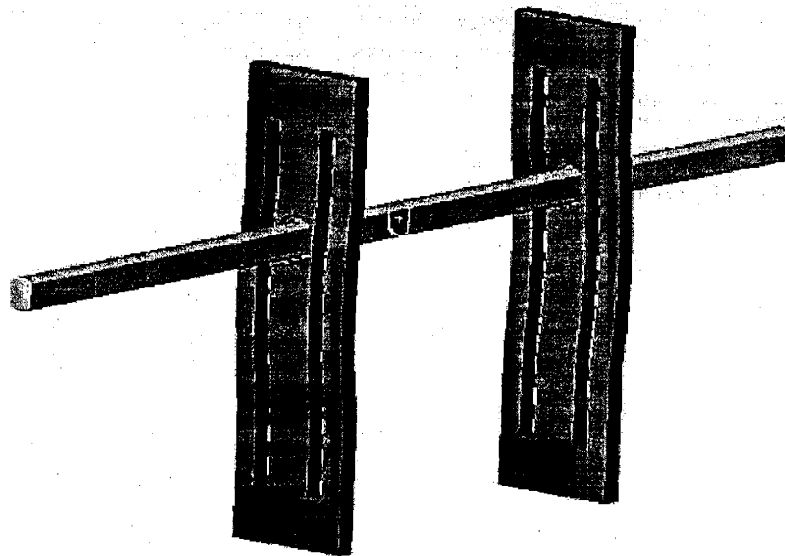

**Figure 3.10**

*The jamming plate and shaft assembly. The geometry of the jamming plates allow for the toggle legs to slide and alternate between the two actuation positions, one at the top of the plates and the other at the bottom.*

The grooves in the plates allow for the toggle legs to attach onto the plates and slide on them. However, they are a source of structural weakness. In order to remedy this weakness, the plates are designed to be thick everywhere except at the shaft hole. At the shaft hole, a small T:D ratio is maintained and the plate's jamming capability is not affected. (Figure 3.13)

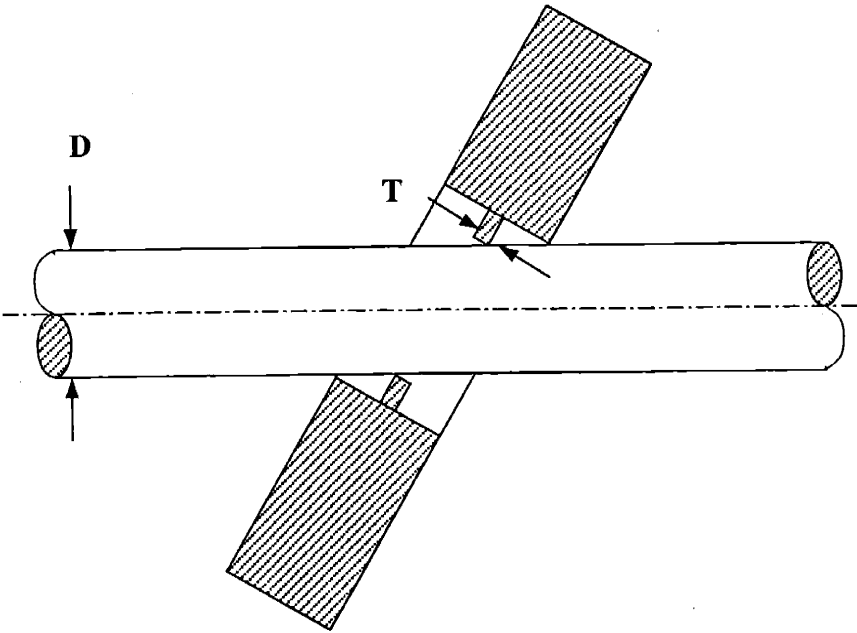

**Figure 3.13**

*Cross-sectional view of a thick jamming plate that has a small effective T:D ratio at the jamming hole.*



### 3.3.2 Toggle Drive

The main requirement for the toggle drive is that it consists of two legs that pivot about a common point or edge. Considering this, it was quite natural to design the toggle drive based on the geometry of a hinge. One of the preliminary design ideas can be seen in Figure 3.14.

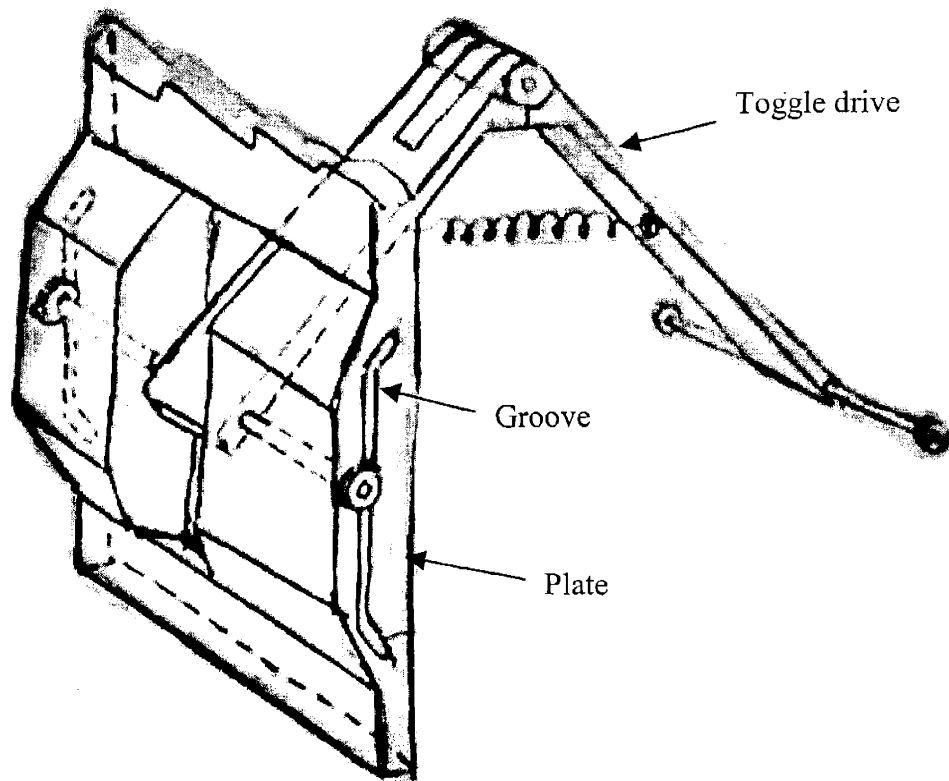

**Figure 3.14**

*An early conceptual design for the hinge toggle drive. The toggle legs slide along the grooves in the plate and rest either at the top of the groove or at the bottom.*

As seen in Figure 3.11, the toggle legs are attached to the jamming plates by a bolt assembly. The assembly consists of a bolt, washers, a spring and a nut. (Figure 3.15) The spring maintains a tight grip on the plate while at the same time, gives the toggle legs the freedom to switch positions on the jamming plate.

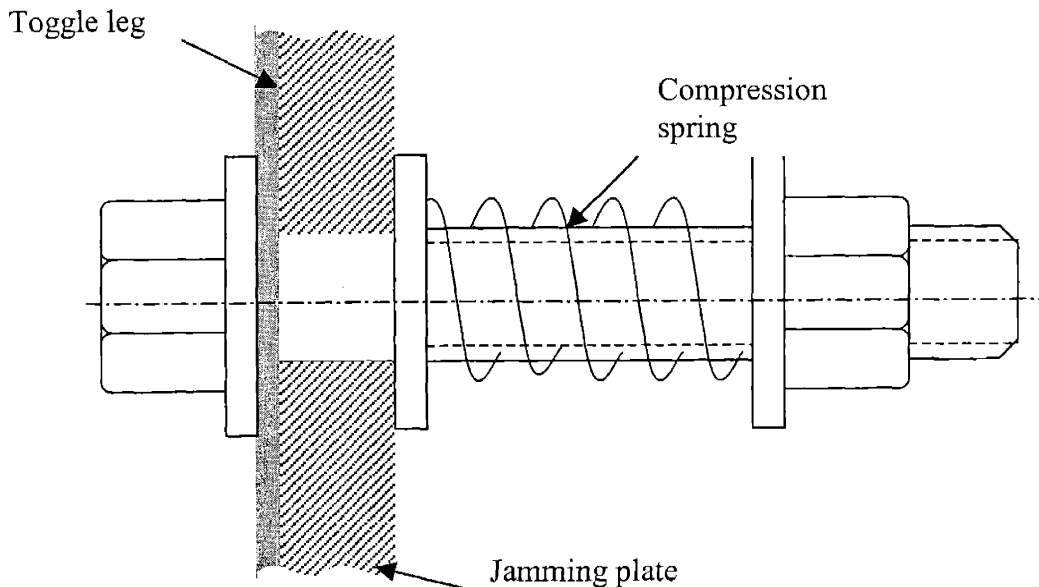

**Figure 3.15**

*The toggle leg is connected to the jamming plate by bolt assemblies which consist of a bolt, washers, a spring and a nut. The spring allows the toggle leg to attach tightly to the jamming plate as well as gives the toggle leg the freedom to shift along the curved surface of the jamming plate.*

In order for the toggle legs to shift orientation, a flexure knob is designed on the legs. The flexure knob bends in one direction but not in the other (Figure 3.16); allowing the toggle to shift positions. The shift happens when the cam changes rotational direction, and an extrusion on the cam wheel pushes on the flexure knob. For example, in Figure 3.7, when the cam is turning clockwise, it hits the left knob which freely gives way. When the cam changes direction, the knob is pushed from the left and the entire toggle will be rotated counter-clockwise.

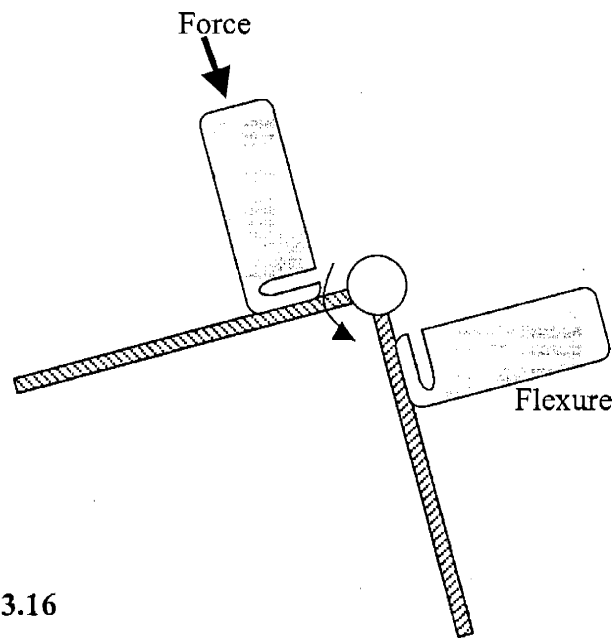

**Figure 3.16**

*Flexure knobs on the toggle legs bend in one direction but not the other depending on the direction of a applied force.*

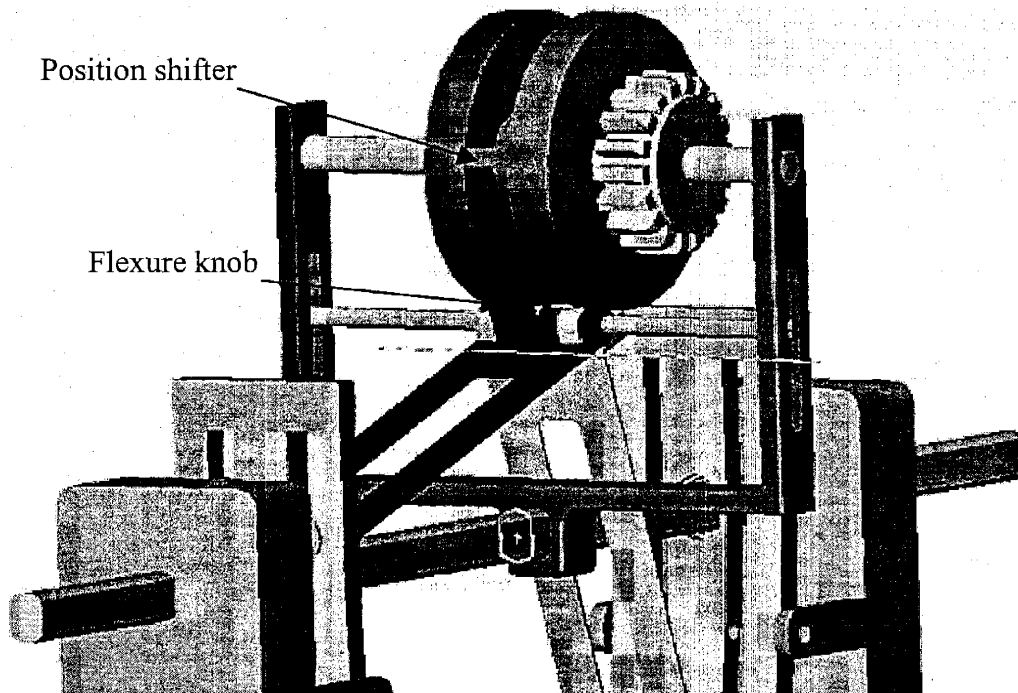
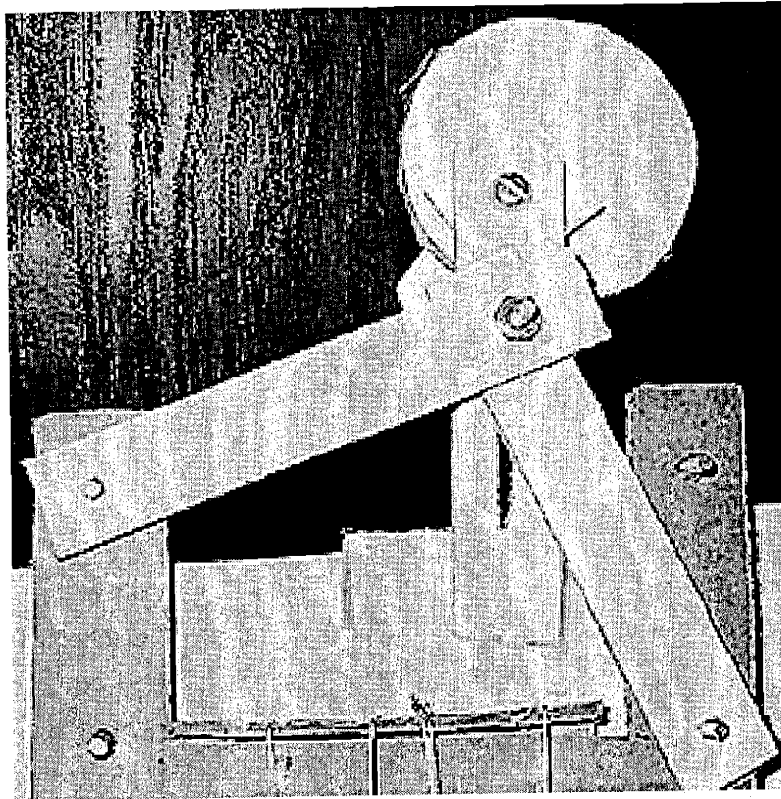

**Figure 3.17**

*When the cam changes direction, the position shifter on the cam pushes on the flexure knob of the toggle leg and rotates the toggle drive to its new position.*

The idea for the cam drive was first tested using a cardboard prototype. (Figure 3.18)

The main difference between the computer solid model of the cam and the cardboard prototype is the addition of the position shifter bar in the solid model.



**Figure 3.18**

*Cardboard prototype of the cam drive.*

Although much time was spent on the conceptualization of this design, a prototype was never built because its complexity made it unfeasible. A simpler solution, one with fewer parts and fewer variables was sought. The final design, discussed in the next section, also uses jamming plates but the actuation mechanism makes use of a wobble plate rather than a cam driven toggle.

## 4. Final Design

### 4.1 Design concepts

#### 4.1.1 Jamming Plates

The sequence of operation for the final inchworm actuator design is demonstrated in Figure 4.1. In the first step, both jamming plates are locked and the system is in its “off” position. The right jamming plate is pushed to the right, shifting the shaft as well as the left jamming plate which is locked onto the shaft. The right plate is then unlocked and as it is pushed back to the left to its original starting position, opens the left jamming plate which also shifts back. At the end of the sequence, both plates lock.

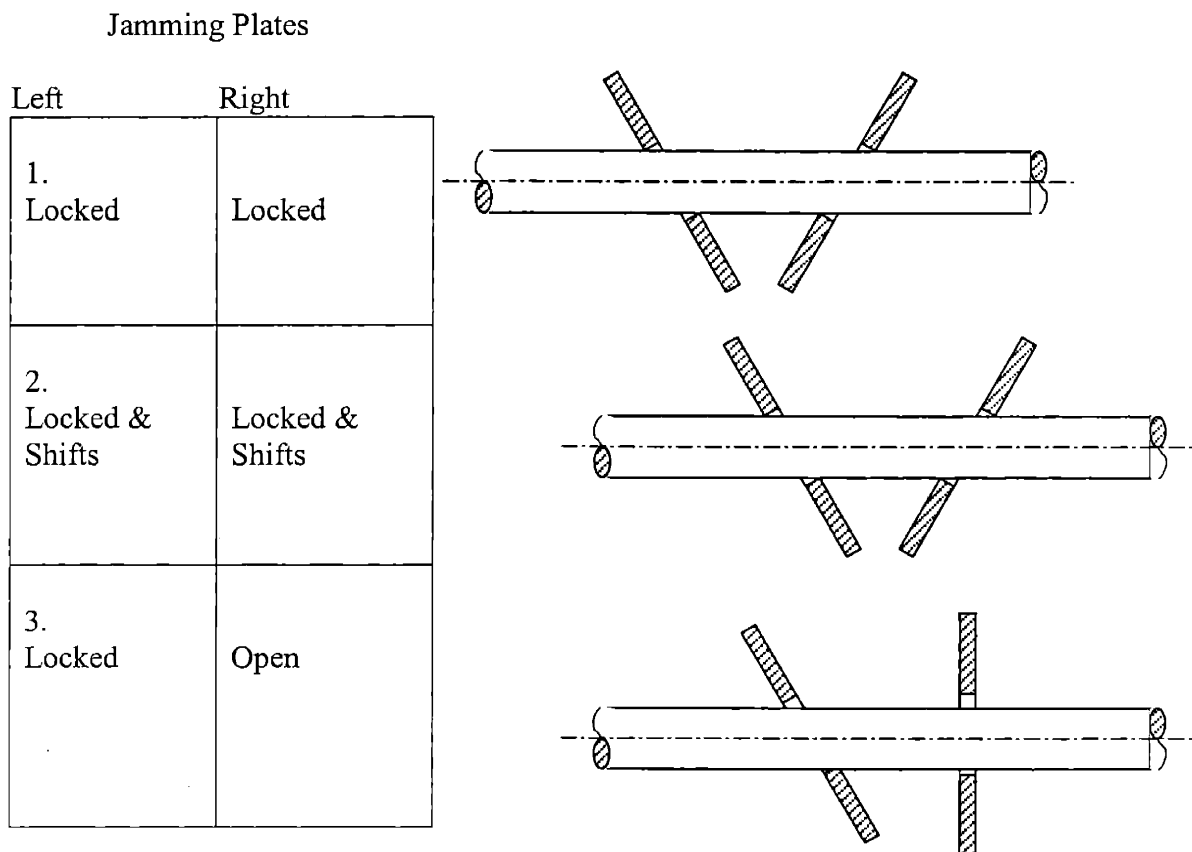

4. Open & Shifts	Open & Shifts
5. Locked	Locked

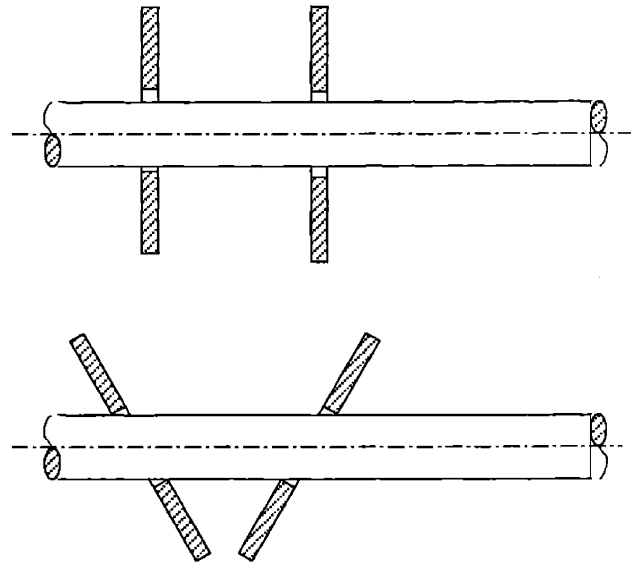
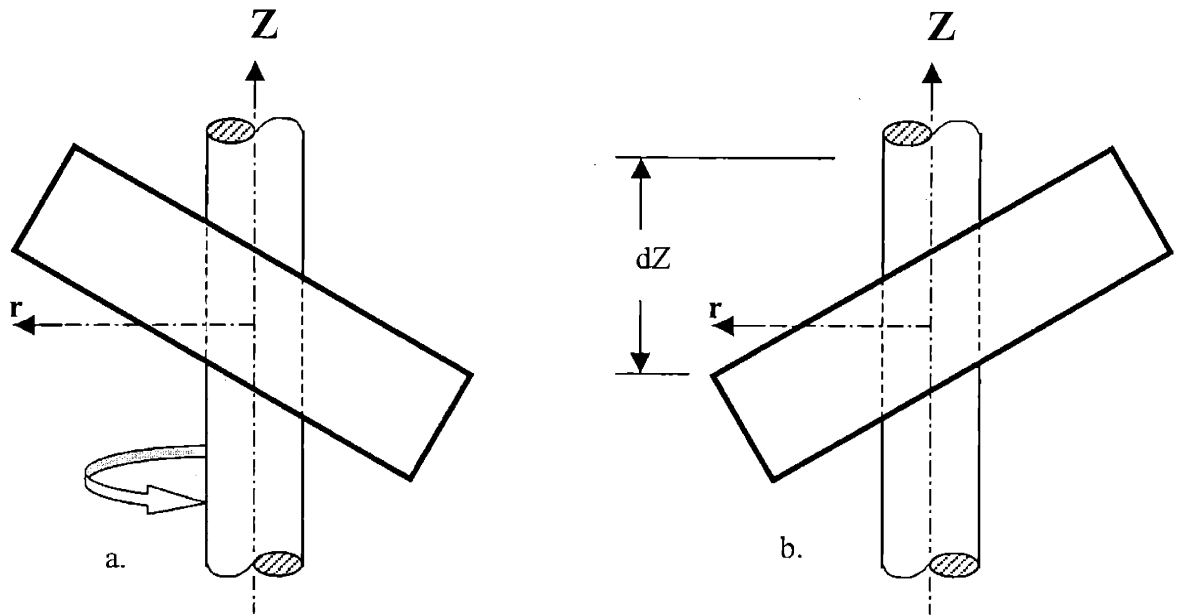

**Figure 4.1**

*Sequence of motions for the jamming plates and shaft.*

#### 4.1.2 Wobble Plate

In the final design, a more compact actuation system that uses a wobble plate was adopted. The wobble plate is the component that changes rotational motion of the motor to lateral motion. Essentially, a wobble plate is just a tilted disk, which when rotated about its central z axis, creates translation,  $dZ$  at a distance  $r$ . The size of the lateral displacement  $dZ$  depends on the degree of tilt of the wobble plate and also on the distance  $r$ . (Figure 4.2)



**Figure 4.2**

*A wobble plate that turns about the z axis. With every 180 degrees of rotation, a displacement of  $dZ$  occurs at a distance  $r$  away from the Z axis. This motion is harnessed to create a lateral pushing force on the jamming plates.*

## 4.2 Design Overview

The final design is composed of two modules, the actuation module and the jamming module. It is small and compact; the total number of parts, not including fasteners is 13 and can be decreased by machining the motor mount as part of the main base.

The parts are:

- |                  |                          |
|------------------|--------------------------|
| 3 shafts         | 1 motor                  |
| 1 motor mount    | 1 wobble plate           |
| 2 jamming plates | 3 tapered rubber sleeves |
| 1 main base      | 1 jamming plate base     |

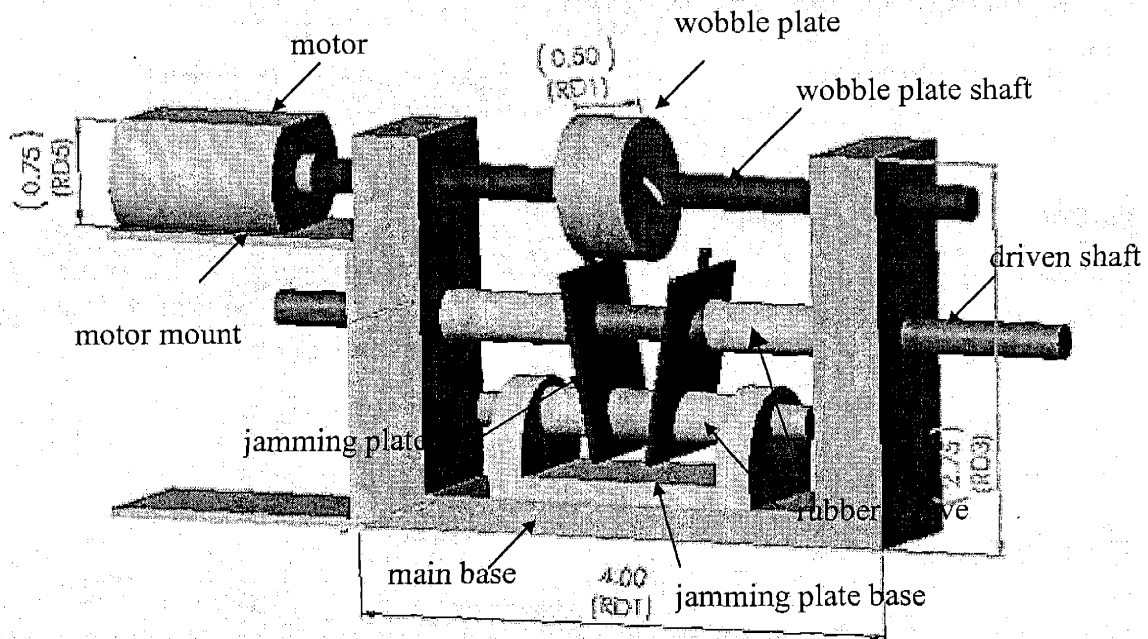

**Figure 4.3**

*The final design as shown measures approximately 4" long by 2.9" tall by 1" wide.*



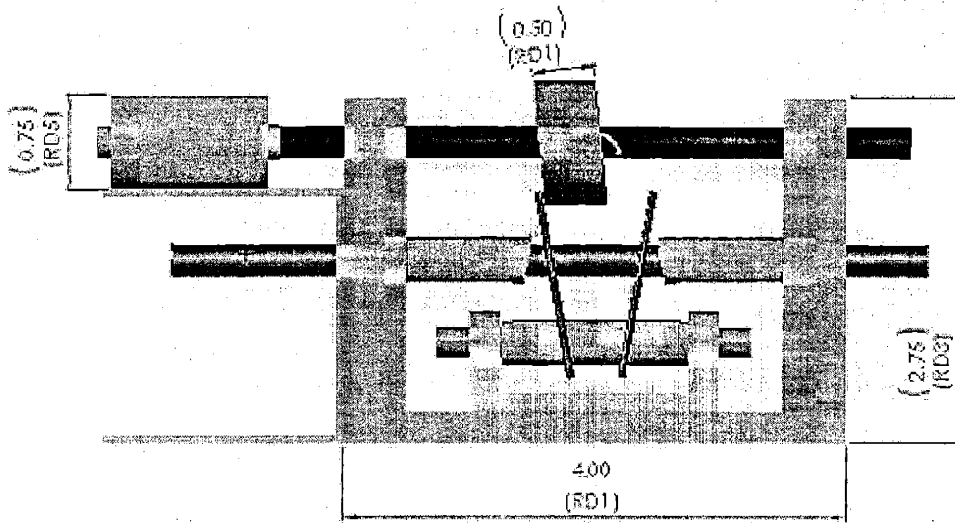

**Figure 4.4**

*Front view of final design.*

### **4.3 Component Design**

The jamming mechanism consists of two jamming plates, a driven shaft, rubber sleeves and a lower mounting shaft. The actuation system consists very simply of a motor driven wobble plate and a grooved shaft.

### 4.3.1 Jamming Mechanism

#### Plates

The crucial dimensions of the jamming plates are bore diameter and material thickness at the bore. Bore clearance should be small such that the plates can engage quickly and securely without much play. The size of the bore clearance determines the plate tilt angle. Other than these two constraints, the plate can be of any shape and size.

Choice of plate material is also very important. Ideally the sharp edge of the jamming hole would not deform as it pinches and jams on the shaft. A dull edge on the jamming hole would decrease the plate's locking effectiveness.

When used in conjunction with a wobble plate, the geometry of the jamming plates need to be altered from a rectangle to a rectangle with a "tooth." (Figure 4.2) The reason for this is that the contact surface between the wobble plate and jamming plate needs to be small to prevent swaying of the plate from side to side when the wobble surface rubs against the plate.

The wobble plate, although a simple solution to creating lateral back and forth motion, is not perfect. The action of a wobble plate is not ideal in this system because force is not only applied laterally (pushing against the plates along the axis of the shaft) but also applied sideways, rubbing against the plates. This decreases the efficiency of the system but may be remedied by introducing a bearing surface at the point of contact, changing rubbing friction to rolling friction.

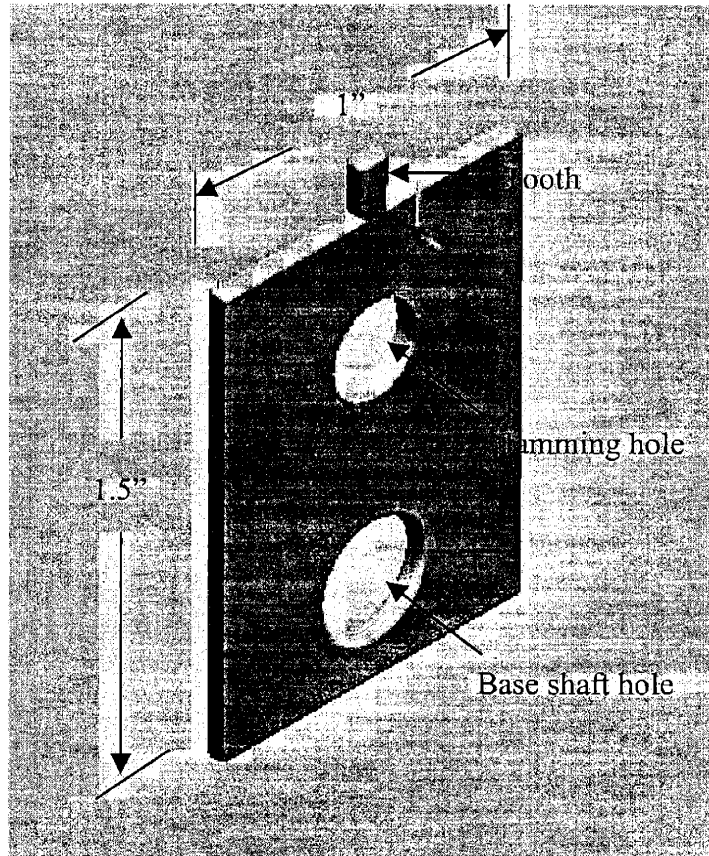

**Figure 4.5**

*When used in conjunction with a wobble plate, the jamming plate should have a narrow "tooth" to ensure a small contact surface.*

Although the diameter of the jamming hole should be accurately controlled, the diameter of the bottom hole is not critical. The bottom hole serves the simple purpose of keeping the plate from swaying side to side. It should be made large enough such that it can move freely on the shaft and would not jam. The distance between the top hole and the bottom hole needs to be such that the bottom hole will not touch the base shaft.

## Rubber Sleeve

Rubber sleeves on the base shaft are used to maintain plate orientation, tilting the plates away from each other. They essentially act as springs, restoring the plates to their stable locked positions when the system is “off.” Rubber sleeves on the driven shaft unlock the jamming plates at the end of their travel, shifting them back to their starting position.

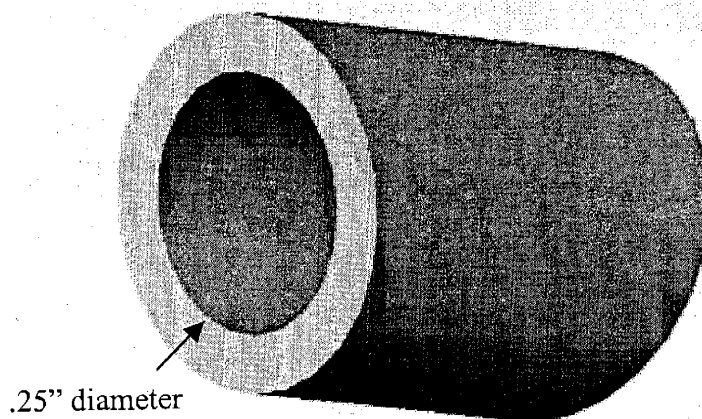

**Figure 4.6**

*The tapered rubber sleeve acts as a spring to provide a restoring force that returns the jamming plates to their locked positions at the end of each motion sequence.*

### 4.3.2 Actuation Mechanism

#### Wobble Plate

The actuation system is comprised of a wobble plate, a grooved shaft and a geared motor that is connected to the shaft. The wobble plate is engaged on the shaft by virtue of a

tooth which rides in the groove like a screw. The angle of the helix is small, covering  $\frac{1}{2}$  the circumference of the shaft.

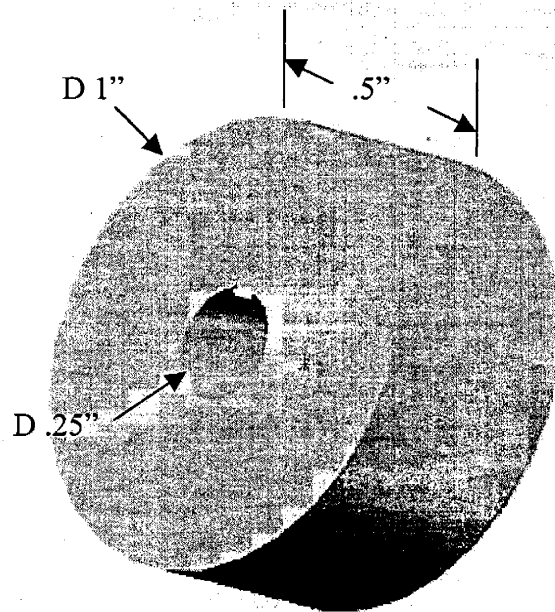

**Figure 4.7**

*The wobble plate has a tooth which slides along the helical groove.*

### **Wobble Plate Shaft**

The direction change of the system is accomplished by the half helical groove on the wobble plate shaft. (Figure 4.8) This groove and the direction of shaft rotation determines which jamming plate the wobble activates. When the shaft turns clockwise (as viewed from the left face of Figure 4.4), the wobble plate moves toward the left.

When the shaft changes direction, turning counterclockwise, the wobble plate moves toward the right.

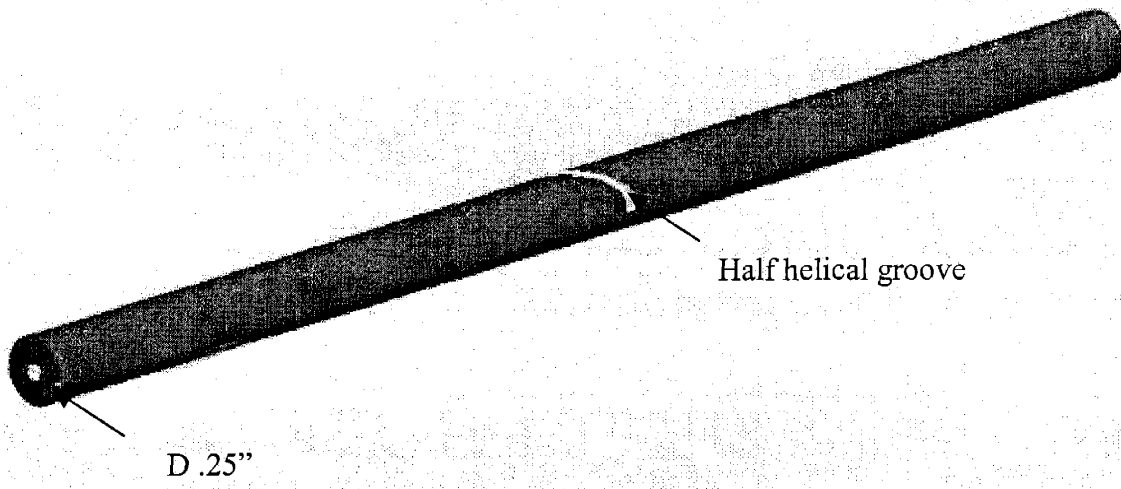
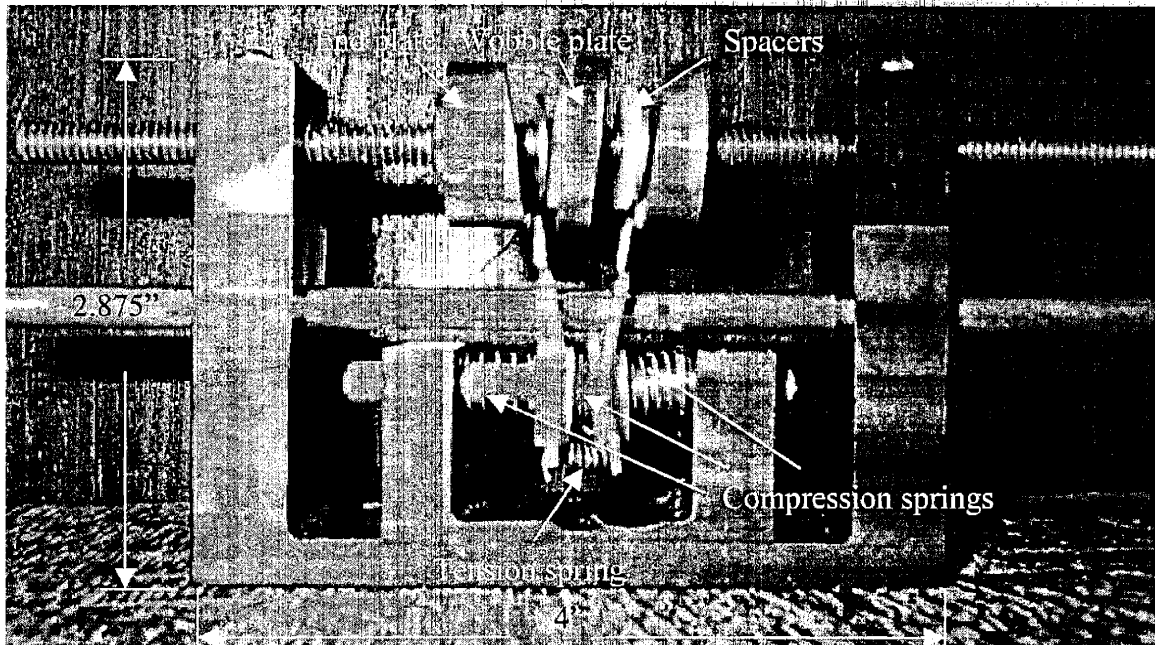

**Figure 4.8**

*Machined onto the surface of the wobble plate shaft is a half helical groove on which the wobble plate glides and shifts position.*

## 5. Prototype

### 5.1 Prototype Overview



**Figure 5.1**

*Front view of inchworm actuator prototype.*

The final prototype measures 4" long, 2.875" tall and 1" wide. In the prototype, design changes were introduced because parts that were more easily machined or attained were used in place of the original designed components. These 'shop floor' changes affected the geometry and use of the jamming plates, the rubber sleeves, the wobble plate and the wobble plate shaft.

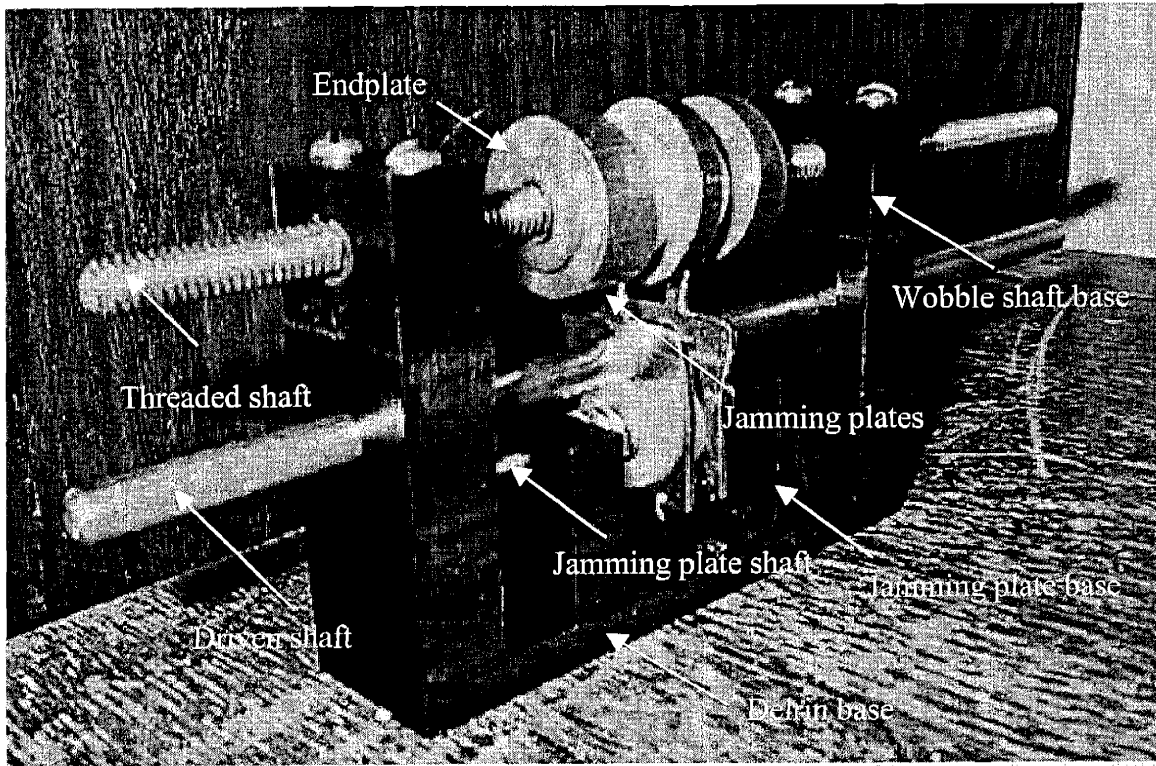

**Figure 5.2**

*Angle view of inchworm actuator.*



## **5.2 Components**

### **Base**

The largest component of the device is the base. The delrin base is comprised of three separate components. The main base supports the driven shaft, a small detachable base supports the jamming plate shaft and small delrin blocks attached at the top of the main base support the threaded shaft.

### **Jamming Plates**

The original material used for the jamming plates was 1/8 inch steel plate, giving a T:D ratio (on a 1/4 inch steel shaft) of 1:2. This thickness did not provide effective jamming and the plates were consequently replaced by 1/16 inch stainless steel plates. The jamming hole diameter was decreased in the new plates, resulting in smaller tilt angles and faster locking engagement. To accentuate the locking effect, the plates were bent.

### **Rubber Sleeves**

In the original design, the jamming plates were tilted by spring flexures or tapered rubber sleeves. However, compression springs were used in place of tapered rubber sleeves and were not effective in tilting the plates in the locked position. Consequently, the plates were bent to achieve the angle needed for locking, but still the locking was weak. In order to remedy this, tension springs were attached to the base of the jamming plates, pulling the bottom of the plates together, creating a strong locking effect.

## **Shaft**

The distinct half-helical grooved shaft in the original design was replaced by a threaded shaft in the prototype. This was done as a simple demonstration to show how the wobble plate would shift from one side to another, engaging either plate depending on the direction of shaft rotation. Consequently, as a result of this alteration, the wobble plate “tooth” which was designed to slide along the groove was replaced by tapped threads.

## **Wobble Plate**

Aside from the introduction of threads, the wobble plate design was altered with the introduction of endplates in a “wobble plate assembly.” (Figure 5.3) The end plates are used to limit the travel of the wobble plate and also to “kick open” the jamming plates during the return stroke. (Figure 5.4) The wobble plate and endplates were originally machined from aluminum, but the high friction between the stainless steel jamming plates and the aluminum wobblers made the threaded shaft very difficult to turn, impinging a high load on the motor. A new wobble plate was made from steel and endplates from brass. In order for the endplates to not jam on the threads of the shaft, the T:D ratio of the endplates was made large and the hole clearance small. Washers were used to space out and align the wobble plate, jamming plate and endplates.

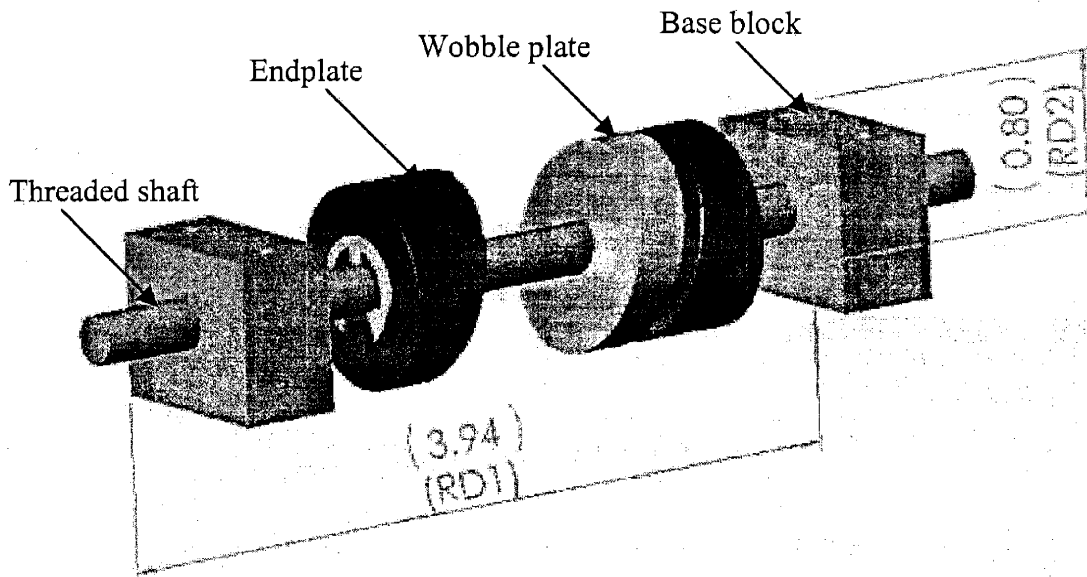

**Figure 5.3**

*The wobble plate assembly is comprised of six main parts: a threaded shaft, two base blocks, two endplates and a wobble plate.*

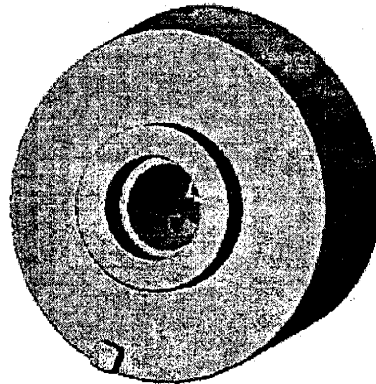

**Figure 5.4**

*The end plates are used to limit the travel of the wobble plate and also to "kick open" the jamming plates during the return stroke.*

### 5.3 Testing

The prototype was tested using an electric drill which rotated the threaded shaft.

Although the prototype was successful at providing inchworm motion of the shaft in one direction, it failed to reverse the shaft driving direction automatically. Instead, manual adjustment was needed to change direction.

In testing the prototype, the wobble plate and one of the endplates need to first be correctly aligned by hand. Once they are aligned, the jamming plate is engaged. As the wobble plate turns, the jamming plate shifts, moving the shaf. During the return stroke of the jamming plate, a knob on the endplate tilts the jamming plate and unlocks it from the shaft. This allows the jamming plate to shift back to its original position and begin the motion sequence again. This sequence happens once for every full rotation of the wobble plate.

When it came time to shift the driving direction of the shaft, the wobble plate did not disengage from the assembly and instead, continued to advance the shaft in the same direction. The reason for this is that the wobble plate and endplate had screwed tight against each other and could only be removed with manual adjustment. The cause of this problem can be attributed to the use of a threaded shaft in place of a shaft with a machined half helical groove. Other problems which were encountered in the prototype are described in the following.

### **Jamming Plate Problems**

The jamming holes were not machined identically, one with a diameter that is larger than the other. This resulted in different bend angles, different effective lengths of travel and different locking capabilities. The plate with the smaller jamming hole was more effective in locking and shifting. This resulted in unbalanced performance but did not severely limit the functionality of the device.

### **Wobble Assembly Problems**

Designed to be an automatic shifting device, the plate should ideally glide along the threads when the shaft turns. By virtue of low surface friction, the wobble plate should move only laterally, screwing across the threads and not rotating with the shaft.

However, in the prototype, the wobble plate did not move easily from one side to the other. The friction between the two threaded surfaces is great and the thread pitch (20 per inch) is high.

Besides the shifting of the wobble plate, the alignment of the wobble plate with the endplate was also problematic. Instead of orienting in half a turn of the wobble plate as was designed, the large thread pitch necessitated many turns. The wobble and endplates would often jam together and not align. (Figure 5.5)

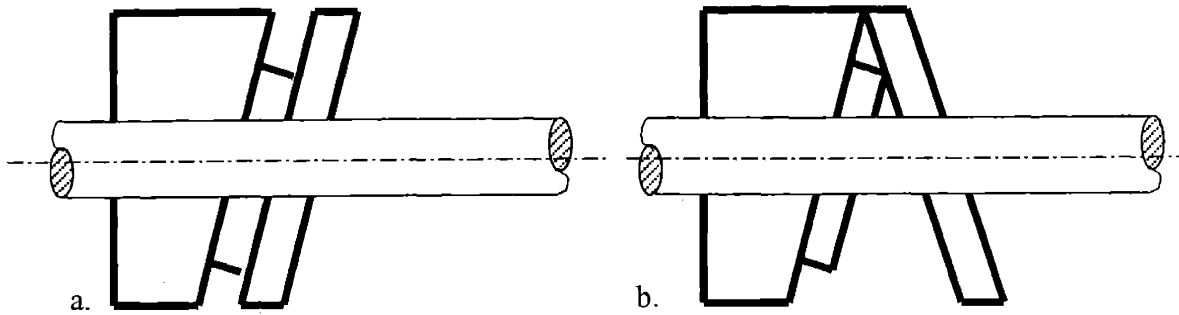
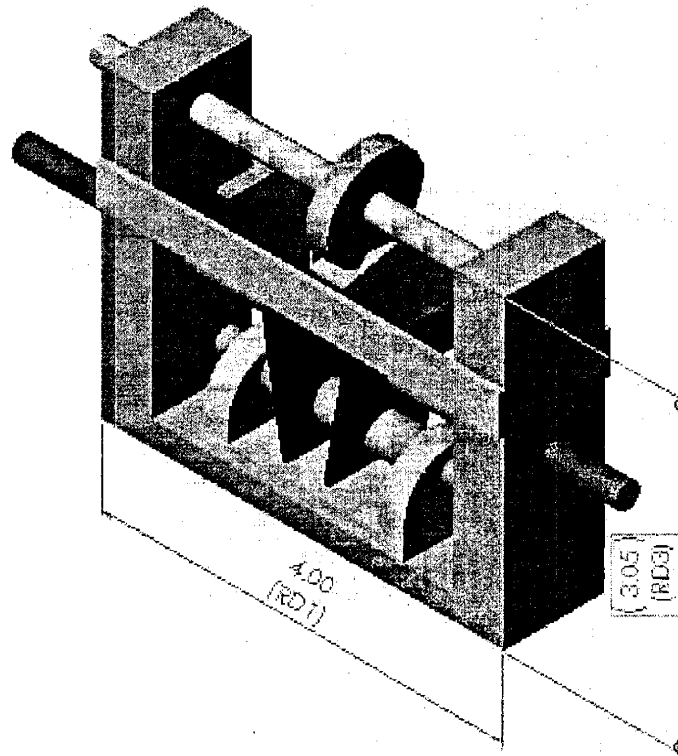

**Figure 5.5**

*Correct alignment of the wobble plate against the endplate is shown in case a. while jamming occurs in case b.*

Even when aligned and engaged, there was the problem of the wobble plate screwing up tightly against the endplate and getting jammed. This effect was foreseen in the building of the prototype and may be remedied by the removal of threads at a position on the shaft slightly before the endplates.

## 6. Future Work



**Figure 6.1**

*Isometric view of inchworm actuator with a plate actuation guide. The guide allows for the shifting of actuation direction without the use of a grooved shaft nor endplates.*

The alignment and shifting issues encountered in the prototype prompted the search for a better shifting mechanism. The simple addition to the system, a plate actuation guide, can be seen above in Figure 6.1. The guide is driven by the wobble plate above and contacts the jamming plates below. This alignment is better demonstrated in Figure 6.2.

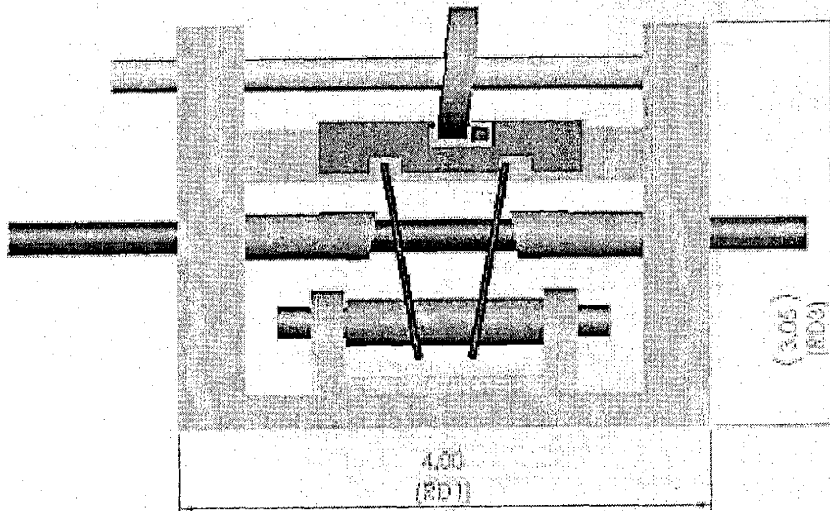

**Figure 6.2**

*Front view of inchworm actuator with the plate actuation guide. The front bracket is removed in order to see the guide's engagement with the jamming plates and the wobble plate.*

Depending on the direction in which the wobble plate turns, the guide will engage either the right or left jamming plate. The sliding knob is the part of the guide which is in constant contact with the wobble plate. (Figure 6.3) When the wobble plate changes direction, the knob slides along the groove in the direction that the wobble plate is turning and stops at the brackets. When the knob is sliding, it pushes the sliding plate so that it engages a jamming plate. Once the knob has stopped at the brackets, the sliding plate is touching a jamming plate. Further rotation by the wobble plate shifts the sliding plate



forward and advances the jamming plate and shaft. The return stroke of the jamming plate is provided by the tapered rubber sleeve which acts like a spring.

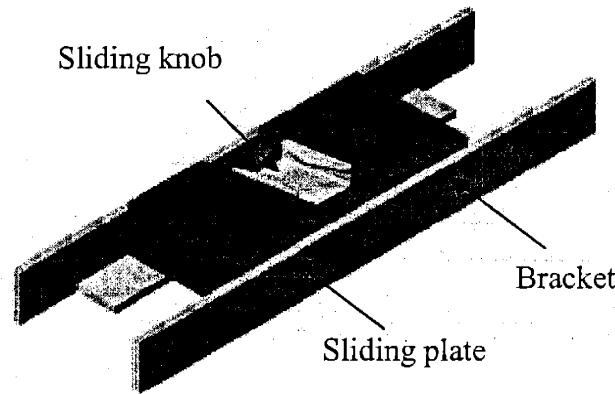

**Figure 6.3**

*Isometric view of plate actuation guide. The plate actuation guide consists of three main parts, a bracket and a sliding plate and a sliding knob.*

With the addition of the plate actuation guide, direction change is accomplished simply by changing the rotation direction of the wobble plate. By virtue of friction, the sliding knob will shift with the rotation of the wobble plate and push the sliding plate along the brackets to engage the opposite plate.

## 7. Conclusion

The purpose of this project was to design a linear actuator that would advance a shaft in step-wise increments, imparting to the shaft inchworm-like motion. Two separate actuator designs were conceived and the simpler of the two was built. The prototype demonstrated the effectiveness of the jamming plates and the potential of using wobble plates to effectively actuate the system. The prototype was able to drive the shaft forward in one direction, however it was unable to automatically shift directions. To correct this problem, a design for a plate actuation guide was conceived; it has yet to be tested and remains as future work.

The consequences of developing an inexpensive linear inchworm actuator are enormously beneficial to industry. The small size and minimal actuation requirements make it inexpensive and practical to use in any system that requires linear motion. The inchworm actuator can replace systems that use, for example, motorized lead screws or solenoids. The versatility of this technology makes further development worthwhile

## 8. References

<http://aml.seas.ucla.edu/index/MGSTR/Magnetostriction%20and%20Magnetostrictive%20Materials.htm>

<http://etrema-usa.com/terfenol/index.asp>

<http://www.delphion.com>

<http://www.ktu.lt/tsc/en/science/nauji/ss04.html>

<http://www.nanocentral.com>

<http://www.nasatech.com/Briefs/Aug99/NPO20272.html>

<http://www.public.iastate.edu/terfenol/homepage.html>

<http://www.txre.net/eng/taoci.htm>

# Appendix

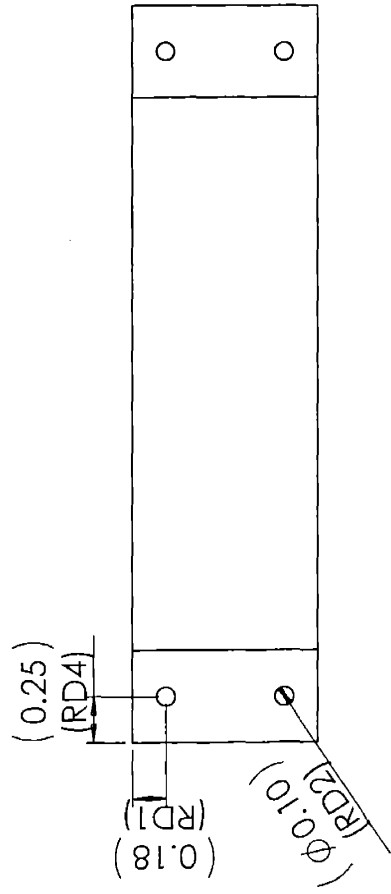
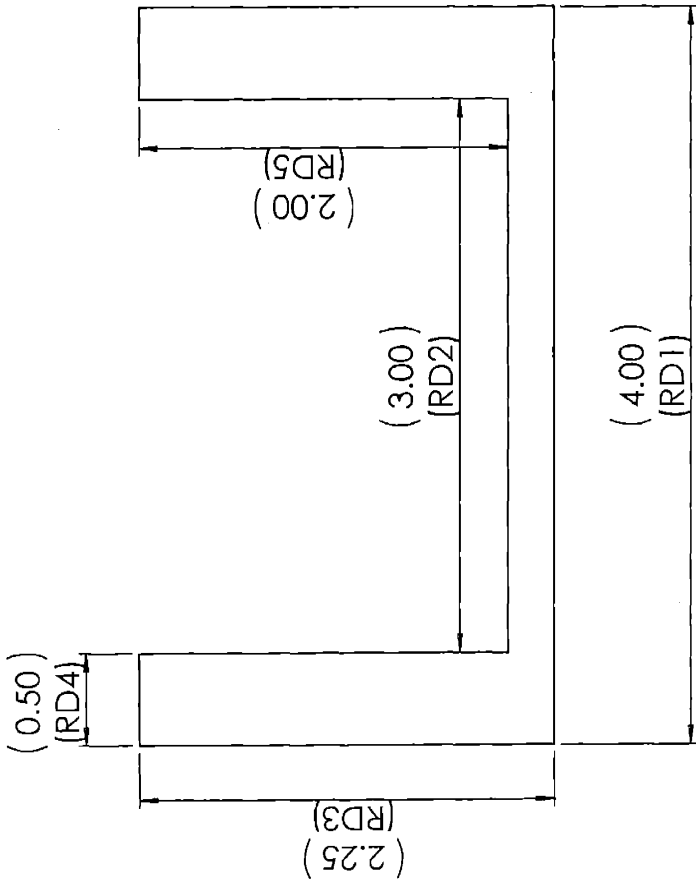
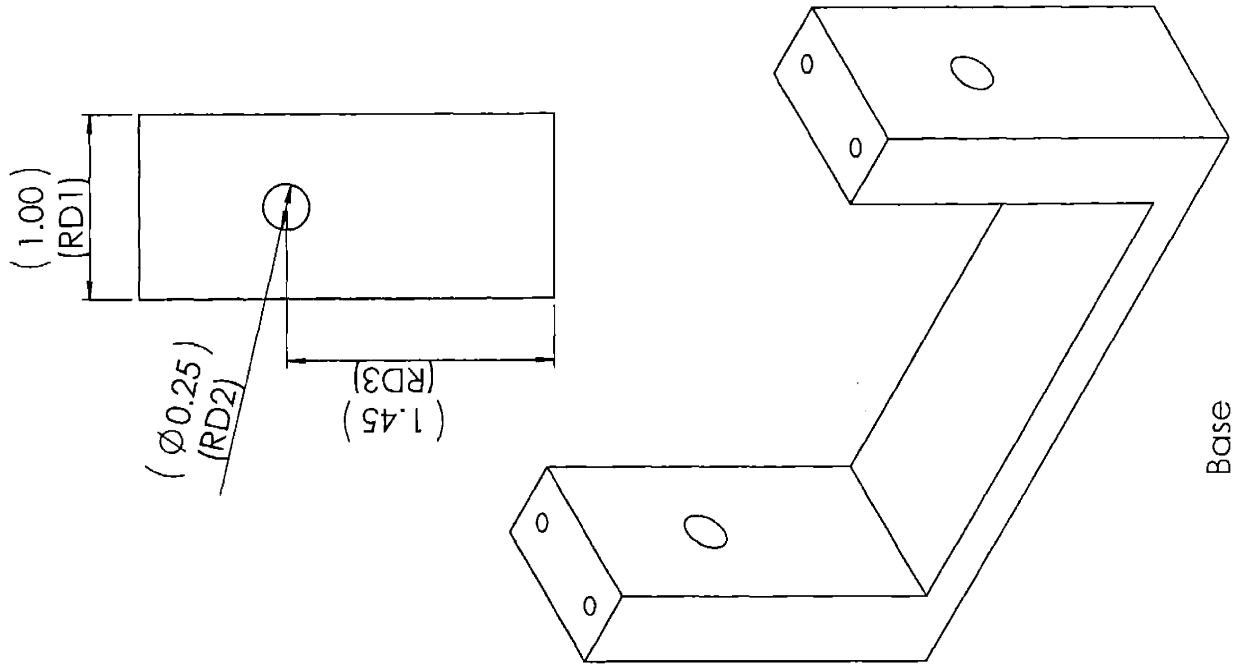

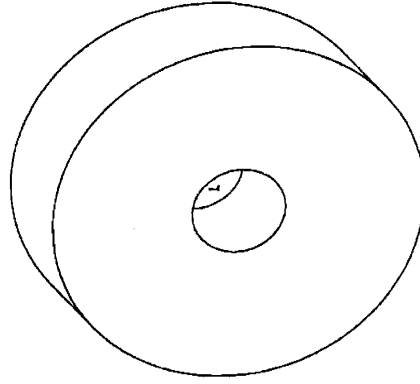
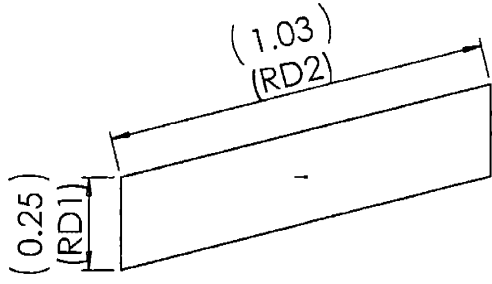

Wobble Plate

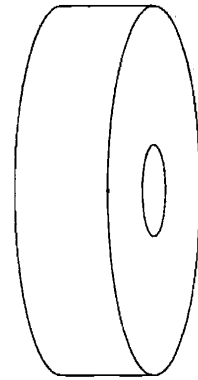
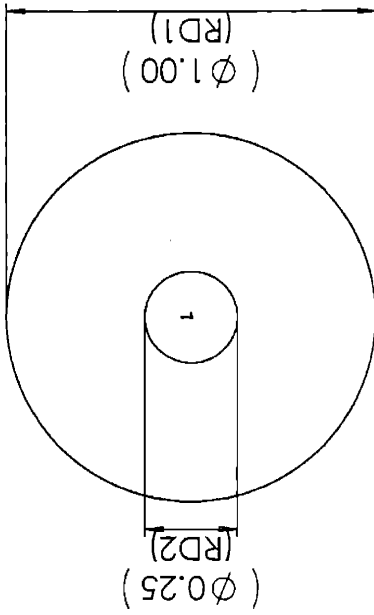

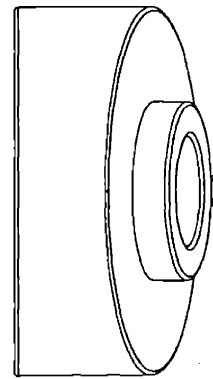
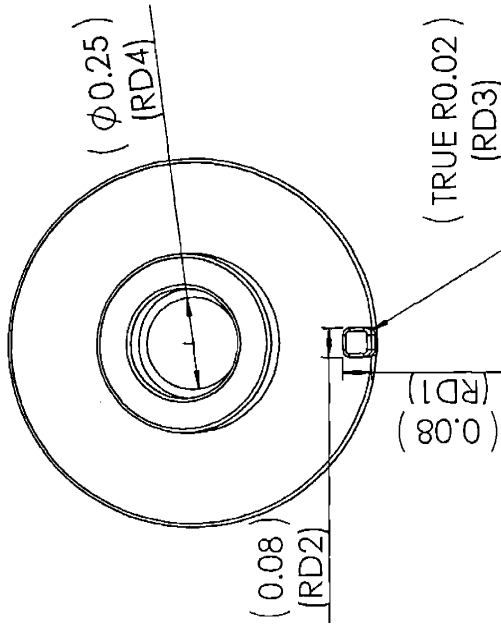
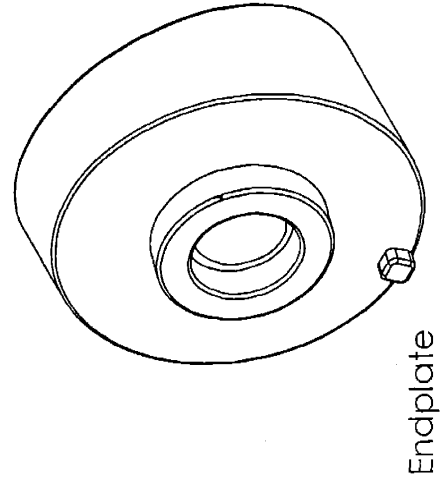
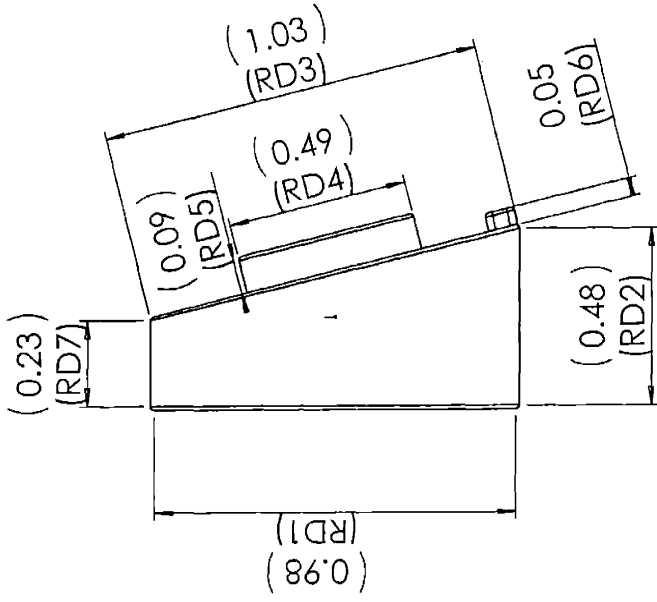

( $\phi 0.25$ )  
(RDI)

(4.50)  
(RDI)

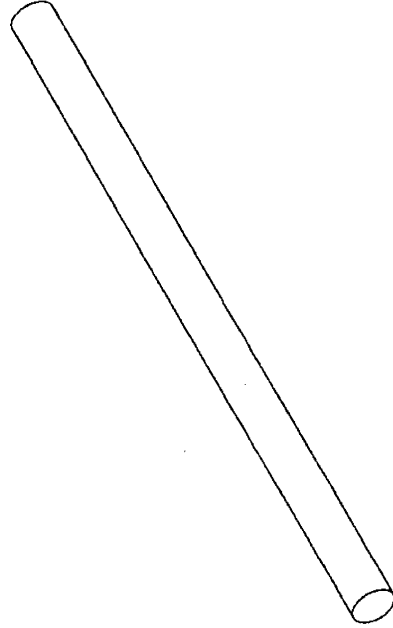
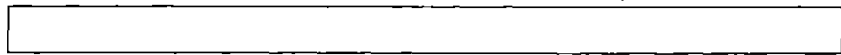
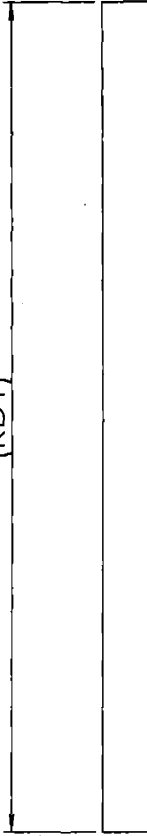

Shaft

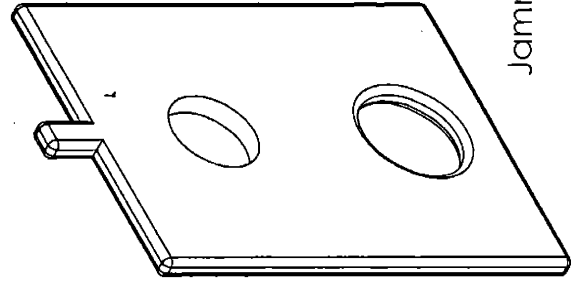
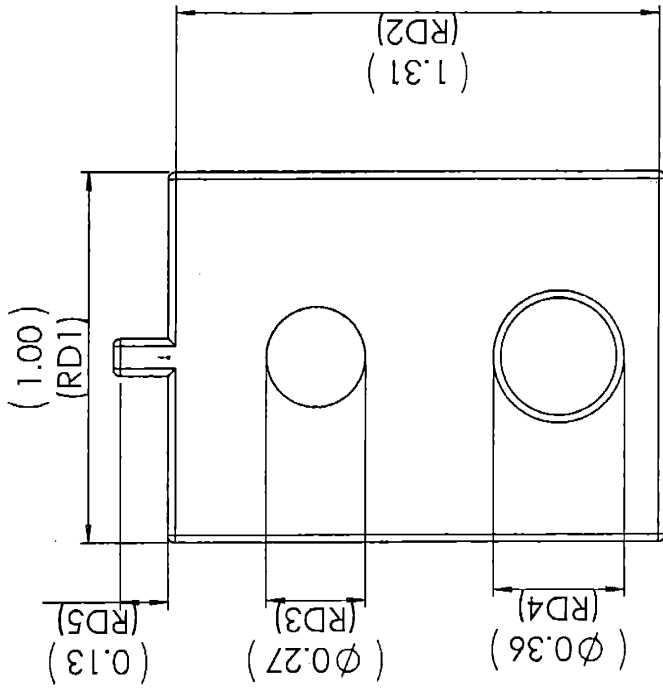

Jamming Plate

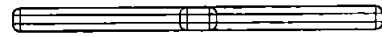
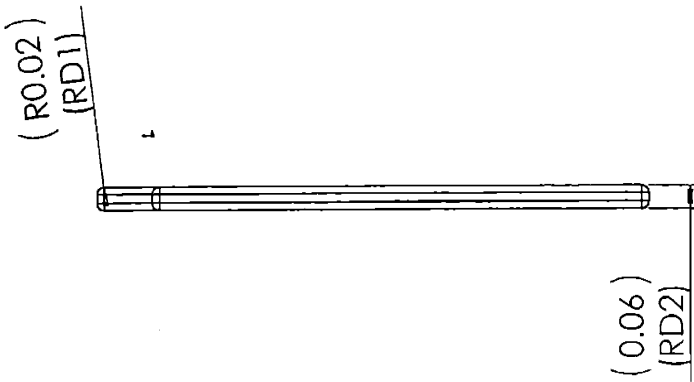



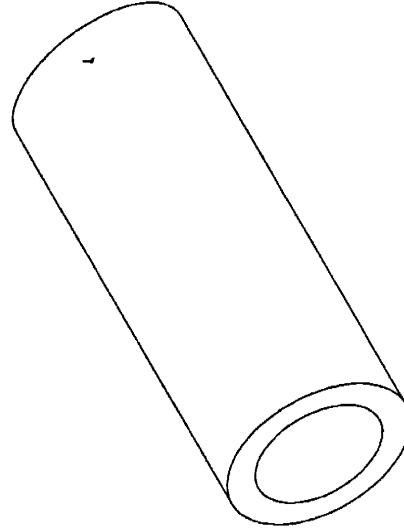
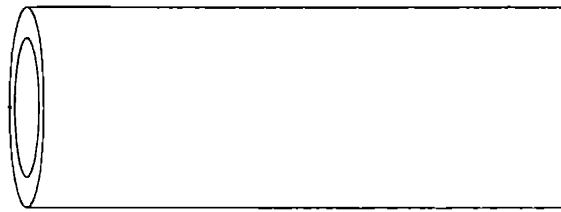
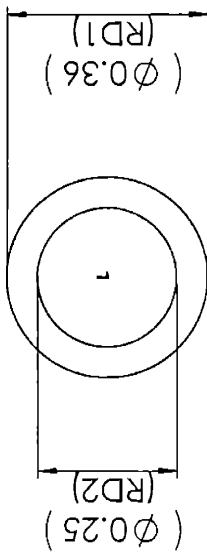
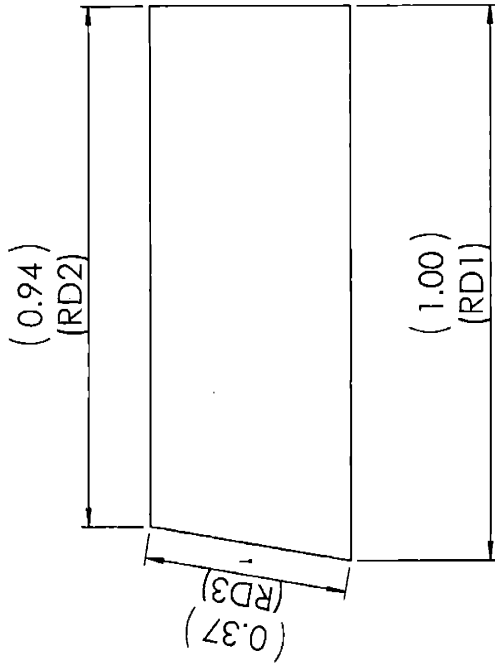

Wobble Assembly Rubber Sleeve

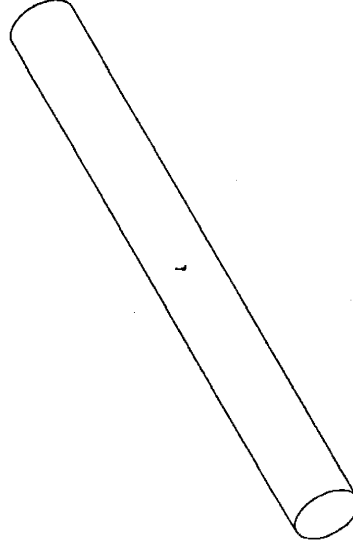
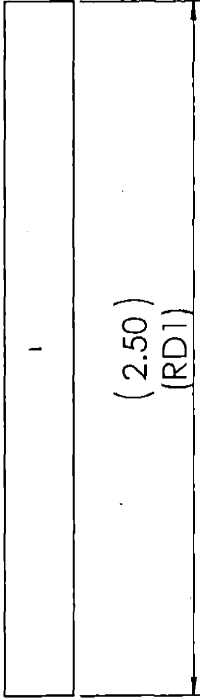
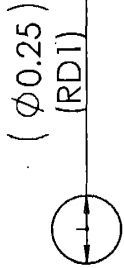

Jamming Plate Shaft

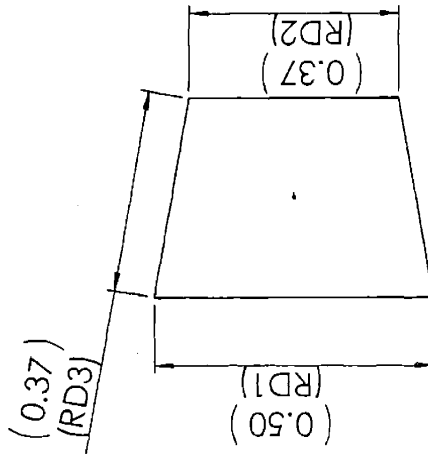
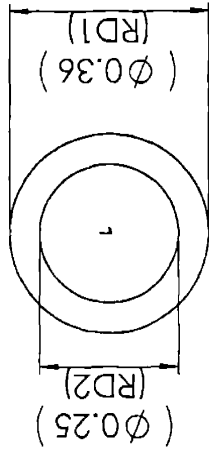
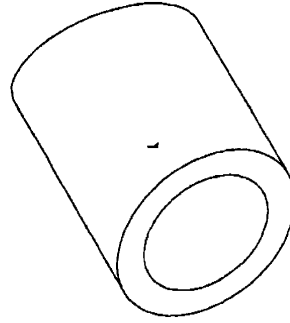
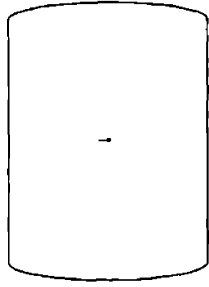

Jamming Plate Cenerter Rubber Sleeve

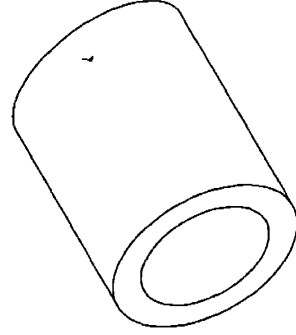
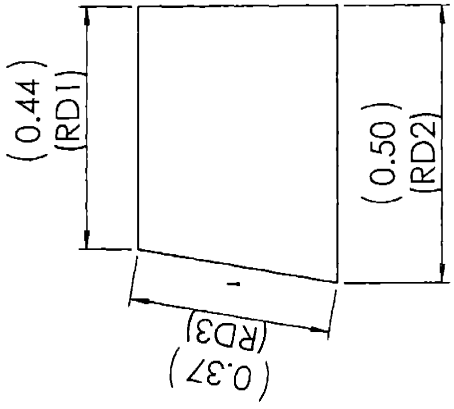

Jamming Plate Rubber Sleeve

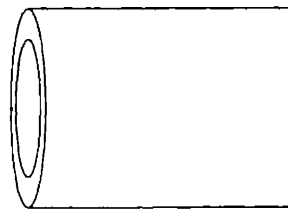
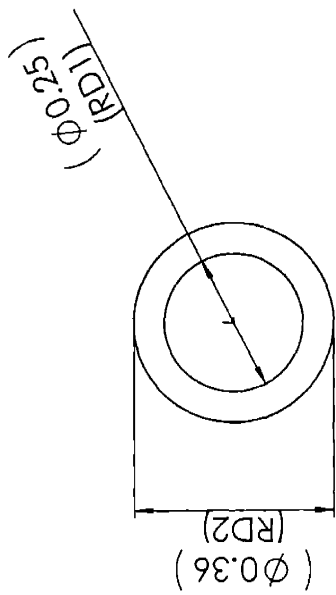

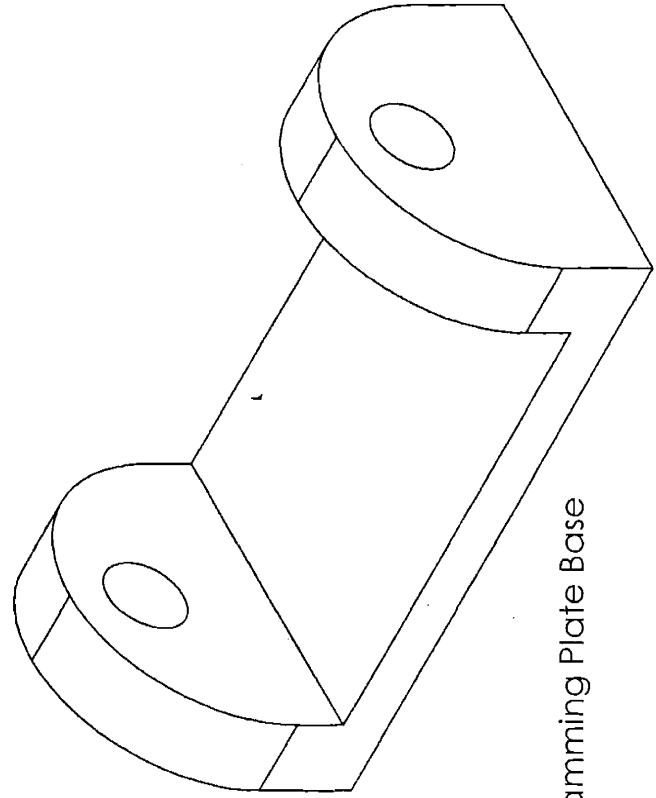
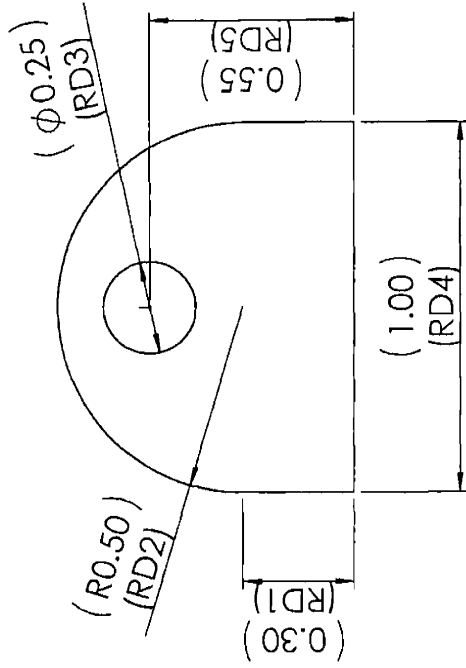
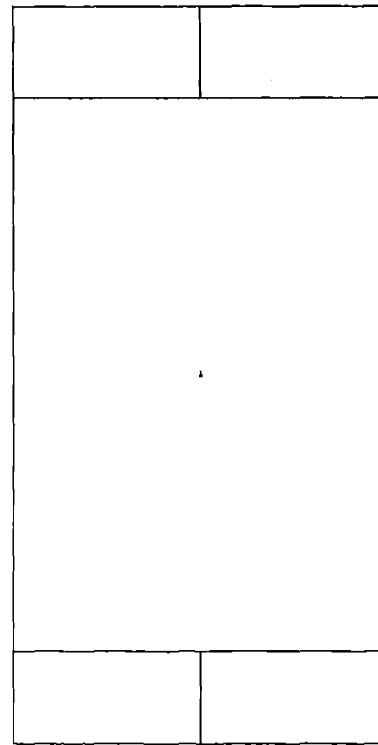
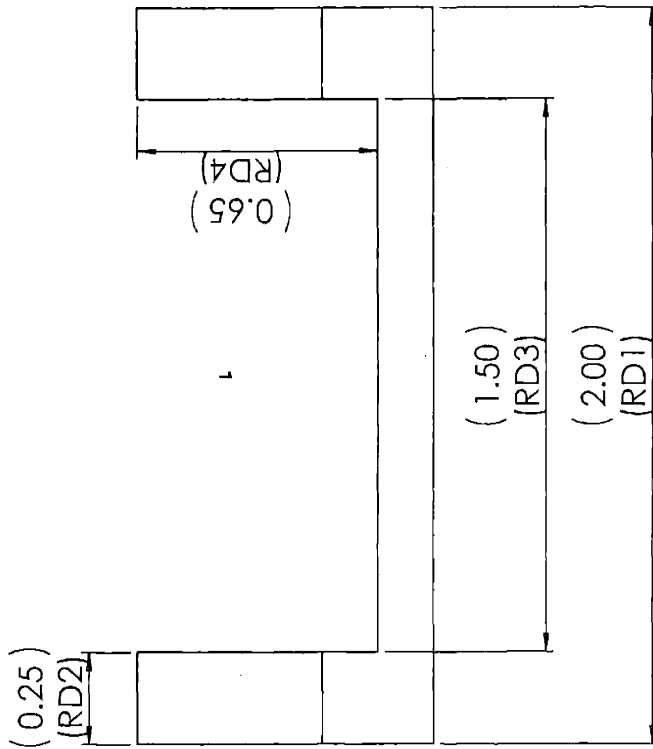

Jamming Plate Base

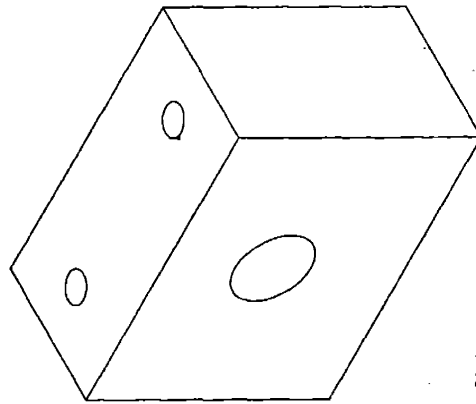
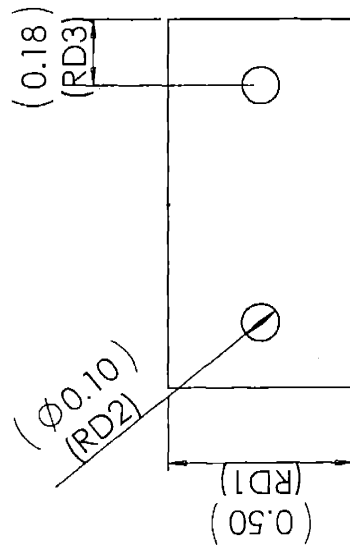
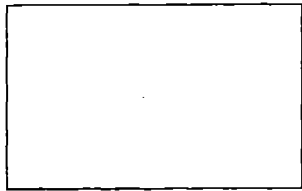
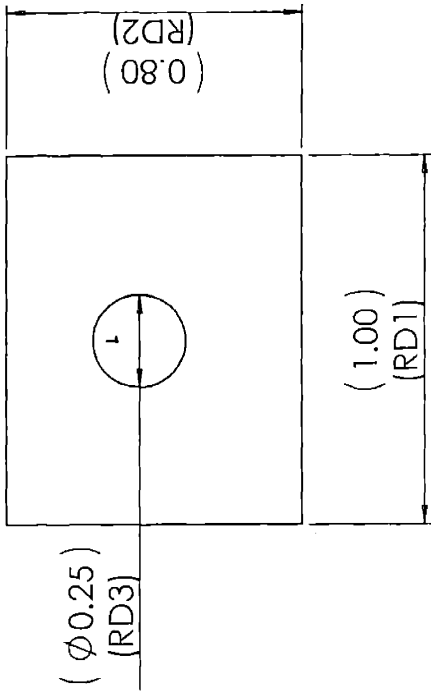

Wobble shaft base