

Puja Pandals: Rethinking an Urban Bamboo Structure

by

Nilay Oza

Diploma in Architecture
School of Architecture, Ahmedabad, 1995

SUBMITTED TO THE DEPARTMENT OF ARCHITECTURE IN PARTIAL
FULFILLMENT OF THE REQUIREMENTS FOR THE DEGREE OF
MASTER OF SCIENCE IN ARCHITECTURAL STUDIES
AT THE
MASSACHUSETTS INSTITUTE OF TECHNOLOGY

JUNE 2000

©. 2000 Nilay Oza. All rights reserved.

The author hereby grants to MIT permission to reproduce
And to distribute publicly paper and electronic copies of this thesis
document in whole or in part.

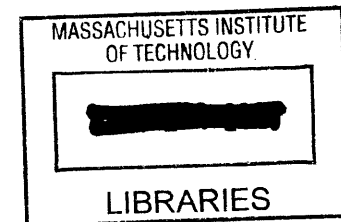
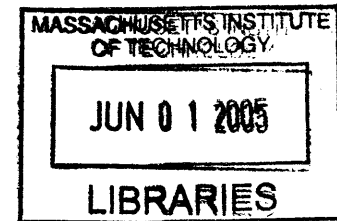

Signature of Author: _____

Department of Architecture
May 18, 2000

Certified by: _____

John Fernandez,
Assistant Professor of Architecture
Thesis Supervisor

Accepted by: _____

Roy Strickland
Principal Research Scientist in Architecture
Chairman, Department Committee on Graduate Students

ROTCH

Puja Pandals: Rethinking an Urban Bamboo Structure

by

Nilay Oza

Submitted to the Department of Architecture on May 18, 2000
in partial fulfillment of the Requirements for the
Degree of Master of Science in Architecture Studies

ABSTRACT

Pandal's are large tent like structures that are recreations of popular buildings, usually temples, built in wood and cloth over a bamboo super-structure. Traditionally they are built for *Durga Puja*, a festival in the month of October in parts of Eastern India.

Today these structures have become expressions of a broader popular culture where themes both religious and non-religious are played out. Building on research on *Pandal's* this study contends that, with certain modifications, bamboo could be used to construct cost-effective, large span, temporary structures in Urban South Asia.

It is also contented that the abundance and availability of bamboo has, to an extent, worked against its intelligent use. Any degree of structural innovation is deemed unnecessary as it is not considered commensurate with its cheap availability. Here the material is valued for its qualities and is not premised on its obvious use and expendability.

Thesis Supervisor: John Fernandez
Title: Assistant Professor of Architecture

CONTENTS

1. The Notions of Bamboo Construction: Its Study and Its Success	4
1.1 Rural Bamboo	
1.2 Urban Bamboo	
1.3 Its Study: Two Directions	
1.4 Its Success: The Hong Kong Scaffolding Industry	
2. The Puja Pandal	10
2.1 The Build Sequence	
2.2 The Builder	
3. A Large Span Temporary Structure in Bamboo – Why?	16
3.1 A Comparison	
3.2 Joinery	
4. The Proposed Joint	21
4.1 Systems of Economy	
4.2 The Bearing Piece	
4.3 Material and Production	
4.4 Conclusion	
Appendix A	39
Bibliography	40



Figure 01: Rural Bamboo

1. The Notions of Bamboo Construction: Its Study and Its Success

1.1 Rural Bamboo

Bamboo lends itself easily to the image of a tropical, humid, rural, pastoral setting. This is an image of bamboo that travelers have used historically. It is an image that has come to load the word itself with a rural, low-tech overtone. Considering that the technologies of building in bamboo have remained simple extensions of what they were in these imageries this assessment might not be so off the mark. This can be said of it even in its more urban avatars, in scaffoldings, temporary structures etc. There could be two broad reasons for this slow development in the technologies of building in bamboo - 1. The material is degradable by nature. Stone or brick were always better substitutes when more permanent settlement was sought. 2. It grows and is used in areas that for other reasons have remained rural.

To add to this, the recent study of bamboo has also been focused on its value as a local technology where it becomes the foil against "modern" substitutes built in materials like reinforced concrete, brick and mortar. The focus of these studies has, over the last three decades, come to define it in terms of a local material that is built using traditional methods or variations there off.

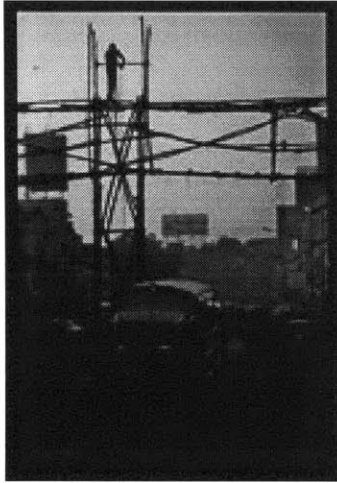

Figure 02: Urban Bamboo

1.2 Urban Bamboo

There is another contemporary setting for bamboo which makes for a drastically different image. This is in the urban, soot filled, agglomerations that some third world cities tend to become. It is a marginal material that one sees intermittently holding up signage, as scaffolding, or in squatter housing. It is green and fresh sometimes and brown, dry and cracked at others but it is a constant presence along with the fabric, wood, plastic, sheet metal and paper that seem to cover parts of these cities like a petunia. It is one of those materials that seem to go through cycles of uses before being spit out of the system as fire wood or simply waste. The economies that operate in it are on the fringe of what economists call the “unorganized sector”. Hugh blocks in economies like India's that account for significant cash flows but remain decentralized and organizationally fragmented.

1.3 Its Study: Two Directions

Having said that the past study of bamboo has defined by how we perceive of it today let me sketch in further detail how bamboo has been studied. As with any field of study these works have followed both the advances in technology as well as the political orientations of their proponents. One broad orientation in the seventies focused on bamboo as a local, low cost, material. Aspects of technology were as important as the social conditions that these technologies occurred in. This fed into the climate of sustainable technology that the seventies were defined by. The other broad direction was focused on the use of bamboo as just a structural material removed from any social condition. The value of these structures were in their use of bamboo in efficient structural forms. Geodesics, inverted-catanaries, and shells were built in bamboo to showcase its structural potential.

There was an over lap between these arenas so that many of the former systems (low cost /socially responsive technologies) began to utilize structural forms that were borrowed from the more structurally driven studies (look at the various examples of bamboo technology using shells for instance (ref. India, Hyderabad, Burma - housing). Even in cases where bamboo did not become a “structure” it was used as a structural element.

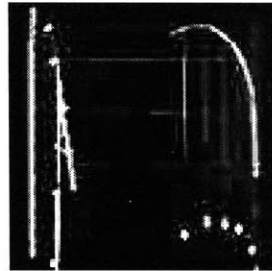

Figure 03: Qualitative Testing

The Institute of Lightweight Structures, Stuttgart

The Institute under the directorship of Dr. Frei Otto had been involved in research on fabric structures and others of similar nature. Bamboo was interesting to them from this perspective; as a material that could be used in making light weight structures. They developed a form of “qualitative” testing where quantitative data was less important as the approach was a sort of trial and error method. Still, there was a systematic catalogue of its properties after a series of load tests. Valuable data was extracted from the tests and studies on the basis of which designs were proposed.

The proposals were based on structures that used bamboo in the clean lines of a material like steel cable. They took their cues from cable net structures and were modeled to function like inverted catenary nets. Geodesics were proposed for bamboo used in short thick segments. These designs did not make use of over-lapping planes of bamboo grids to derive rigidity like most bamboo structures tend to do. One of the reasons could have to do with their unfamiliarity in dealing with bamboo joinery. Most details at the joints employed a “prosthetic” approach, steel clamps were used in favor of a more traditional bound joinery. In most triangulated structures stress is concentrated at the joints, where the stress changes directions, this probably compelled the designers to employ systems that were know to them.

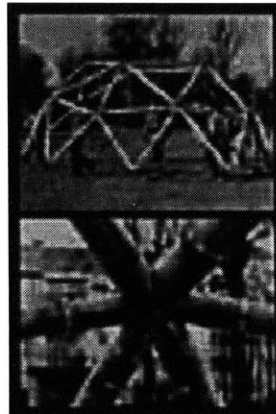

Figure 04: Geodesics : A
“prosthetic approach to joinery

Here, bamboo was seen as the repository of structural ability and the task was to utilize that ability in some way. Most often its ability fell short of expectations, especially in very efficient structures. In retrospect this seems selfevident as a geodesic is a structural system based on an abstract, mathematically defined, function that implies the absence of redundancy and bamboo is a natural material with imperfections and thus redundancy. But, more importantly, this had to with an issue of joinery. Bamboo as a material can be very efficient but as a structure it is patently not. This is because the joinery cannot impinge upon the structural integrity of the rod – (no cuts or splays) i.e. no nails, bolts or screws because they will tend to split the material along its fibers. And joinery that ‘clasps’ the rod fails under high tensile or compressive loads. The only exception to this is in situations where the rode is under direct axial compressive load and the joinery is on the far ends of the rod.

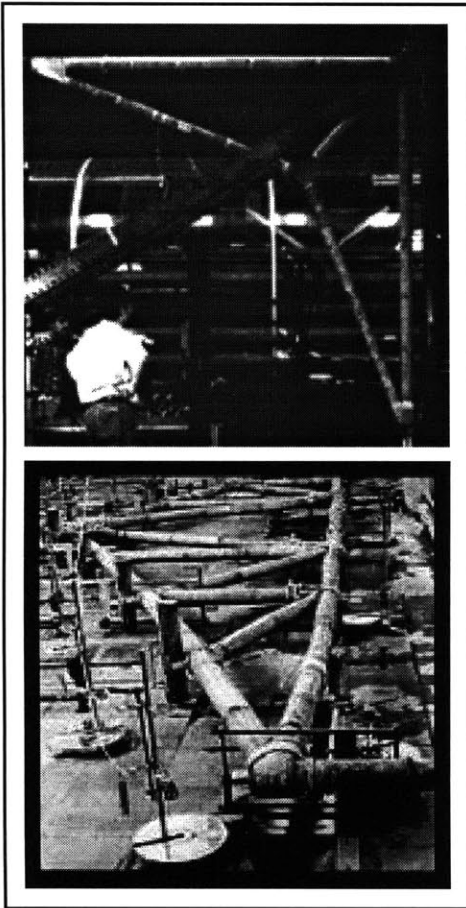

Figure 05: Load Tests on conventional structural forms at the Technical University of Eindhoven, Netherlands

The Technical University of Eindhoven, Dr. Jules Janssen

Dr. Janssen's work on the structural analysis of bamboo is in the mode of a traditional engineer. He does not come with any specific a priori design ideal like say cable-net structures or geodesics. His agenda however is singularly premised on minimizing redundancy and increasing efficiency. What this leads him to is specific research in new methods of joinery and more conventional structural systems. Thus if Otto explored the capabilities of bamboo in forming geodesics; *alternate technology*, Janssen makes bamboo trusses to meet specific structural criteria; *appropriate technology*. It must be said that Janssen's field of research is broader as it encompasses issues of preservation, transport and building. ~

Both these approaches are fundamentally similar in that a structural system developed for other materials and contexts was applied to bamboo i.e geodesics, shells and trusses. They began from a perspective that was alien to the people who worked in the bamboo industry and where expert knowledge, load testing and costly prototypes were what drove innovation. As discussed earlier they are centered on low redundancy and complex detailing. This is important from the perspective of this study which tries to develop a methodology where innovation does not necessarily imply an intrusive radical shift from a method of work. Having said this, I still cannot discount the success that Dr. Janssen's work has had in the innovative use of bamboo, especially in developing earthquake resistant housing in Peru, 1982 and Frei Otto's work in bringing its structural ability to the fore.

But in spite of the invaluable data generated from the efforts both at the Institute of Lightweight Structures, Stuttgart under Frei Otto and The Technical University of Eindhoven under Jules Janssen any form of innovation was not triggered in the bamboo industry. One of the reasons for this was to do with a clash of two distinct systems of thought. The institute brought a thinking that defined a very fine factor of safety; little could go wrong if success was to be insured. On the other hand for the bamboo craftsman/builder redundancy in the making of bamboo structures was a truism that took in the vicissitudes of bamboo's structural character. Redundancy will remain in the nature of bamboo construction in as much as it still remains in wood structures. Only a method

that works on a balance between reducing redundancy without intruding on indigenous methods of work will be most successfully integrated into the bamboo industry today. That is not to say one need not try and use bamboo efficiently – in fact there is a vital need for that the reasons for which we will come to later. The aim should not be the removal of redundancy all together but to trim it down to allow the structure to perform more efficiently.

To understand the nature of this reduction I will look at an urban bamboo structure that would benefit greatly from streamlining the building process. This is in the contemporary practice of building *Puja Pandals* in Calcutta and Delhi. But before that I'd like to briefly introduce another practice of urban bamboo construction that has become established as an industry.

1.4 Its Success: The Scaffolding Industry in Hong Kong

Almost all scaffoldings in Hong Kong are made in bamboo. The “industry” is well developed with a highly trained work force. The Training authority has a certified 6 month training course that workers need to go through to be accepted in to the union of scaffolding workers.

The structure is basically a large two or three dimensional planar surface that is attached to the face of a building. This surface is built with a few species of bamboo depending on requirements. The lowest level of the structure is usually made of Fir wood. The next hierarchy, set inside this Fir grid is made of bamboo of a particular species, *Denodrocalamus* or *Phyllostachys* (*maao-chuk* in cantonese), set on a 10 foot centers grid. And finally a 1-1/2 foot grid is layed out within the *maao-chuk*. This is the grid upon which the workers weight is directly supported. This orthogonal field of bamboo is now given some lateral stiffness by partially triangulating it with a cross bracing with Chinese Fir poles at 20' intervals. Stiffness is also given by attaching the scaffolding to the building frame with 6mm dia. Mild steel ties pre-cast in concrete at 3 meter vertical and horizontal intervals.



Figure 06: A worker on a scaffolding in Hong Kong

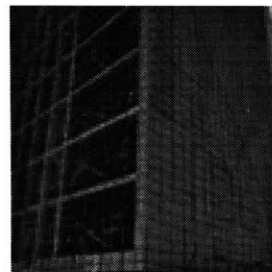

Figure 07: The scaffolding resolves to a 1-1/2' dimension

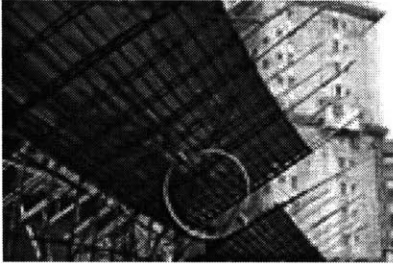

Figure 08: The Catch Fan, a safety mechanism to prevent falling debris from hitting the street



Figure 09: The Hong Kong - Shanghai Bank Building was built in large part using bamboo scaffolding

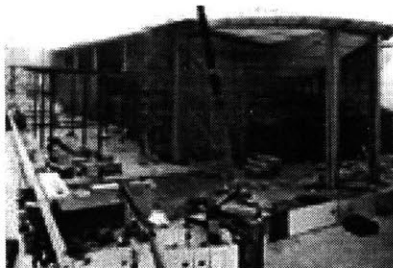

Figure 10: The Macau handover Pavilion, Macau

There are three basic configurations this system is used in. The first and most common is a single-row scaffolding system. At HK\$18 to HK\$25 per square meter it is the most cost-effective system of scaffolding and as the name suggests it is simply a grid of bamboo lashed together with a "dimpled" nylon chord. The next is a double-layered system, basically the former system placed in two layers with a gap of 1-1/2' and this system costs about twice as much (HK \$50 or \$60). The last is a safety mechanism called a catch-fan which is an inclined plane attached to the building face above street level (HK \$200 per running meter) to prevent falling debris from hitting the street.

The scaffolder works with a basic set of three tools: A large hacksaw (to saw off excess lengths of bamboo); a hooked knife (to cut excess lengths or loose bindings); and a wire cutter to cut steel wires used to tie the base tier of fir poles. They also carry bundles of 12' length dimpled nylon cord. The dimples help in maintaining the tightness of the joint, prevent it from becoming loose.

In as much as bamboo scaffolding has come in to the main stream of the economy it still retains vestiges of its former traditions. Organizationally the guilds of workers are headed by a master-craftsman who is accorded the title of *si-fu* (master). And it is filled with superstitions that are also thumb-rules for safety procedures, for instance, it is not considered proper to have a scaffolding dismantled by anyone other than individual who put it in place - for obvious reasons. At the same time that the industry has grown out of a tradition it has had to do this by constantly negotiating with it to become a commercially viable system of construction. The following section will study another tradition of bamboo construction that is gaining popularity in urban India and is now just coming onto this cusp between a "tradition" of building and an "industry" of building; *Puja Pandals*.

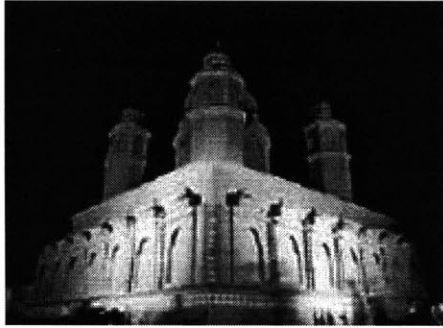

Figure 11: A *Pandal* - bamboo, wood framing and colth

2. The *Puja Pandal*

Pandals are recreations of popular buildings, usually temples but they can be other non-religious buildings also. They are built as temporary abodes for the Goddess Durga. She is venerated in Bengal, Bihar and around other parts of Eastern India. The tradition of the Durga Puja as a communal event has its roots in Bengal of the 18th century and is connected to politics of the time as much as to its religion. The celebration of Durga Puja was said to have been started by one Nawa Krishna Deb, a private tutor to Warren Hastings (the then Viceroy). It was both a religious event as well as a celebration of the British victory in the battle of Palashi against the dominant Muslim rulers. The first account of a large scale Pandal in a large communal event was in 1757, in Calcutta, for one of these events.¹

Even today the structures can be read as ciphers to a popular sentiment. They have grown into an expression of popular culture where various themes both religious and non-religious are given expression without any form of mediation. In the recent past, their popular flavor has extended their use beyond the specific purview of *Puja Pandals*, they are now built for marriages, political rallies and other events. Yet these are only in specific instances like when a structure is required to supply the excesses of the marriage industry in India with a suitably

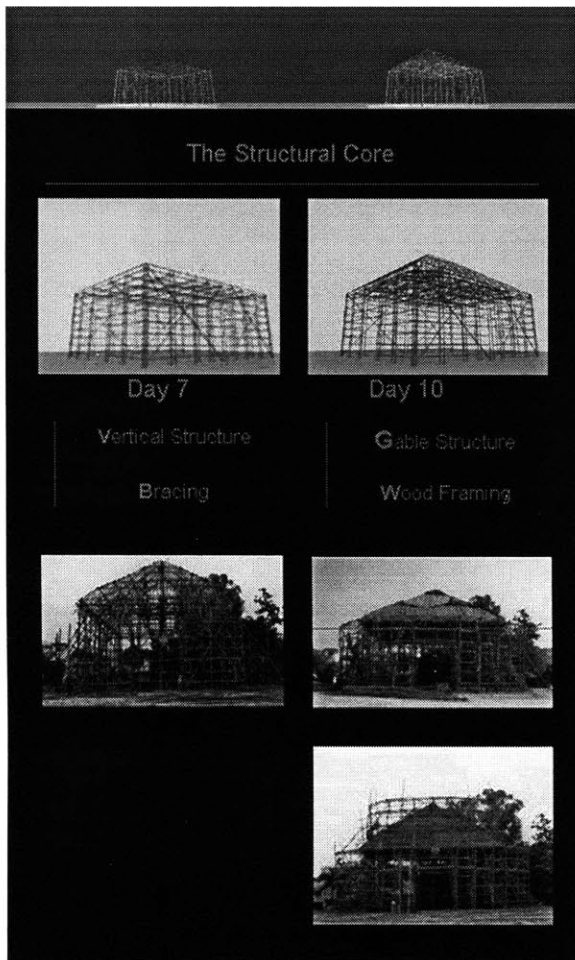

Figure 12: The "Structural Core", A barn like gable roof above and around which the external form is constructed

excessive replica of a Greek temple. The contention this study makes is that bamboo structures can become a viable, cost effective means to erect temporary structure in Urban South Asia. The first step will be to study the structures and how they are built to see what, if any, changes need to be made.

The building of the generic *Pandal* follows some steps common to all bamboo structures and some that are specific to *Pandals*. Joinery, for instance, is common to most temporary structures like scaffoldings built in bamboo. The joints are lashed (tied) with materials like jute. Jute being a natural material similar to bamboo, has the same degree of expansion and contraction with the changes in ambient humidity and has worked quite well for the many bridges and similar structures all over Asia and South America for centuries. Fire off course is a major problem and this has prompted the scaffolding industry in Hong Kong to use a dimpled nylon cord in place of jute rope.

2.1 Build Sequence

On an average it would take about four weeks to built *Pandals*. Also all *Pandals* follow the same basic structural system. Over the course of the first couple of weeks all *Pandals* would look the same as they are all based on a barn like gable-roofed structure which is eventually encased inside every *Pandal* – this is the structural core and holds the structure up. Placed on top and around this structural core is a superstructure that defines the variation that each specific structure might have. There are a few reasons for this.

1. This makes the erection of every structure simpler – The builder after determining the size of the desired structure can begin the erection of the structural core such that it is completely enclosed by the larger external form. The structural core is defined by experience and is built along some tried and tested methods – the number of bamboo poles, the amount of jute and their configurations are know with a fair degree of approximation from prior experience. The idea behind this is that work can begin on site immediately. The only time lag involved between a commission to build a *Pandal* and rigging the first pole on site is an operational one of getting the material to the site. Concurrently with the process of building the structural core the mechanisms of building the rest of the form is developed.

2. Other operational aspects like the laying down of a water proofing membrane is on a form that is topologically familiar, i.e. the flat surfaces offered by the gable.

3. By using the structural core as a platform to further build upon the structure can be raised up higher, at times up to twice the height of the ridge. For the purposes of *Pandals* this is a valuable effect as it gives an impression of a larger structure.

To begin with there is a need to introduce in this system a variety of pre-defined forms that could be used as the internal support structure. In the case of the structure under consideration a variant of a cylindrical base with a conical roof instead to the gable roof could be better suited to the overall form. The basic principle being that a series of primary shapes that could be better suited to a wider variety of outer forms could streamline the construction process.

After the structural core has been completed and a layer of water proofing has been applied (usually canvas). The inside becomes habitable and work can proceed both on the inside and the outside of this surface. The interior is then usually decorated with folds of cloth in vivid colors such that the light that filters in from the outside brightens the volume. The outside of the gable is concurrently being built upon piece by piece into the desired form. Once the bamboo assembly is complete wooden frames are nailed to the bamboo and cloth is covered tightly over it. There are also

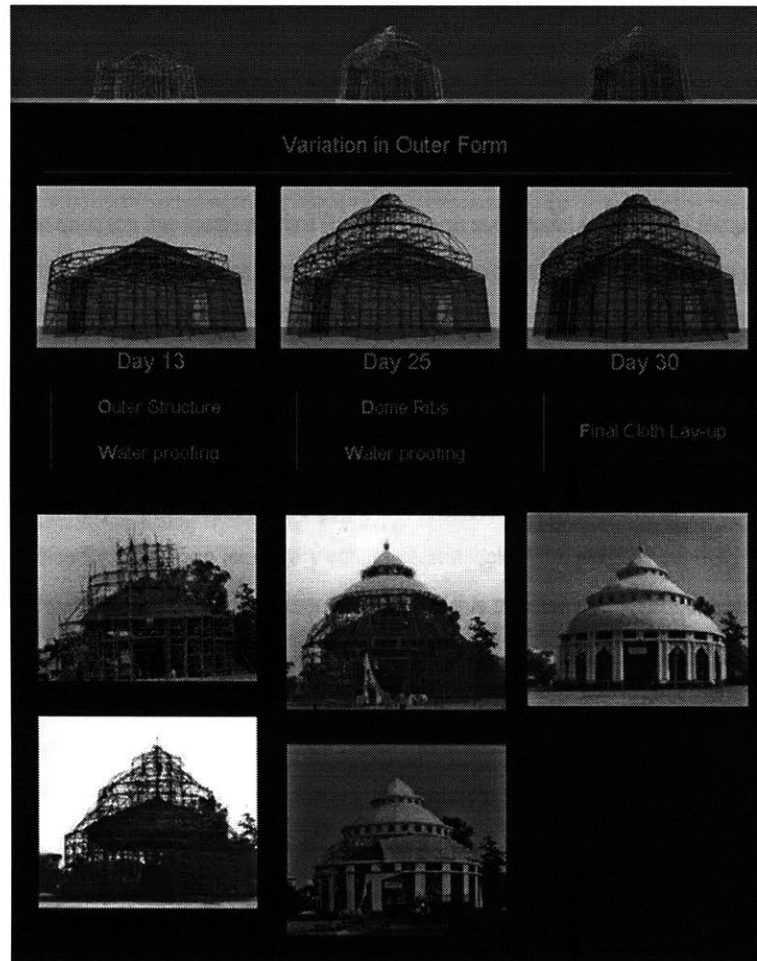

Figure 13: The external form is built around this core in a manner that work can proceed simultaneously both inside and outside this internal form.

some prefabricated panels built that are then nailed at a later stage. In this manner the entire structure is made ready over the course of just 4 weeks or less. In many instances the electrical and HVAC utilities are put up just after the gable form is completed.

The question this thesis asks is if Pandals are so successful as a form of temporary large span construction why they are not the structure of choice for the building of temporary structures in general? In most cases some form of tubular steel construction is used. The reason for this lies partly in the nature of how the structures are built, partly in how the labor that builds these structures is organized and partly in the nature of bamboo itself. Much like the scaffolding industry in Hong Kong discussed in section 1.4 with certain strategic changes in how *Pandals* are built their construction could be streamlined and perhaps they could become viable systems of temporary construction. Before going on the specific reasons as to why these structures are not the system of choice for large span temporary construction a look at the people who build these structures and their notions of “building” would put in clearer focus where this tradition of construction stands in the contemporary world.

2.2 The Builders

There are guilds of craftsmen who build these structures. Out of season, when not building the Pandals, they find employment in the scaffolding industry. And fitting a classic third world demographic profile some return to their villages for the harvest season. If one were to investigate their notions of building and for that matter ‘technology’ are we arrive at an understanding that is fundamentally different from our own.

A master builder, *Sardar*, leads these guilds. Under him fall the trades, craftsmen who work in bamboo, cloth, wood, lighting etc., these are the *karigars*. The labor often join a guild at an early age, work with one *Sardar* for 10 or 15 years, then start their own groups or specialize in some aspect of the structure to be hired as freelance *karigars*. More often than not the *Sardar* is supplied with a design which needs to be replicated; it is usually a photograph of a historical and/or famous building. He then proceeds to diagrammatically layout the structure. This diagram is very crude and probably serves only to determine a rough estimate of the required material.

Immediately then a footprint is laid out as a series of spaced columns followed by a vertical weave of bamboo that begins to define the super-structure and as explained in the preceding section to build the structural core. This weave has a geometric logic, a pattern of load transfer. It must be made clear that the idea of static equilibrium is an abstraction, a realm of numbers that falls outside the purview of the *Sardar's* conception. The material as a tactile object, a repository of certain properties, understood through experience and trade define how and in what quantity and configuration it will be employed. If one were to continue along this trajectory in defining the Pandal builder's conception of building it begins to resemble how medieval builders and craftsman thought of building. This affinity is more than just a curious fact it defines a "mode of thinking" that describes how bamboo structures are conceived of and built today.

This mode of thinking became outmoded along with the dramatic shift in the nature of work from that which used "instrument or tool" to one where "machines" become pervasive. Actions that make use of tools have similes to actions performed by the human body. So, a hammer extends a hand, a flute extends the throat and so on. In contrast a machine is a device whose motion is distinct from the powering agency, the hand. So the bow drill, the pedal lathe etc. are early examples of machines. For the purpose of this short diversion suffice it to summarize that for a machine the entire work-action of making becomes something separable from and external to the original agency; the body. This shift has an effect on the type of abilities or knowledge that are required of the person using the "instrument" or "machine" in the act of making. What this "act of making" means for the medieval /Pandal builder and his tools is that skill, *tekhne*, is still considered the locus of both art and technical knowledge. According to Bruzina in *Research in "Philosophy and Technology"* (1982), what is perhaps more fundamental is a corresponding mentality that this independence of making from the body fosters. It is indeed an implicit metaphysics whereby this separation and independence from human sensibility is taken as the basic feature of our reality, a reality surrounded by machinery.²

Clearly the former attitude to making and thinking is akin to how Pandals are put together, and it is here that the anachronism that characterizes the Pandal maker, his kin, and their work can be situated in our times. This method of thinking, outside science as it were, still sees in the *Sardar's* skills both an engineer and a designer.

Furthermore, *Pandals* and for that matter all work in bamboo utilize little in terms of tools and virtually no machinery, more than the physical nature of their work this has a bearing on their thinking. Thus a concept like “efficiency” cannot become the central thrust of their efforts. It is a factor but not the goal. It would seem to suggest then that the change from tool to machine does not automatically imply or immediately effect a changed mentality. This explains, to an extent, the *Pandal* makers today surrounded by mechanization yet oblivious of its application or impact on their own work. Today then there is a need to gradually change their mode of thinking without forsaking the richness that their work exhibits. Redundancy, for more reasons than one, needs to be minimized. But rather than propose a method that approaches the design of these structures with solutions that seem to have been derived for materials other than bamboo. The suggestion here is to improve structural ability through a transfer of technology, but within the working scheme of the bamboo craftsmen. These observations will come into sharper focus once the issue of what needs to be designed, why and how they need to be designed begin to be answered in the following sections.

¹According to Das the Hindu elite embraced British rule and the Muslim Nawabi culture saw this as an end to their position of power. Thus the celebrations were an affirmation of the British presence with a public “Hindu” religious event, N.N.Das, Calcutta the Living City: Volume 1, pp. 163, 1982.

²Ronald Charles Bruzina, Art and Architecture, Ancient and Modern, Research in Philosophy and Technology, Volume 5, pp. 163-187, 1982.

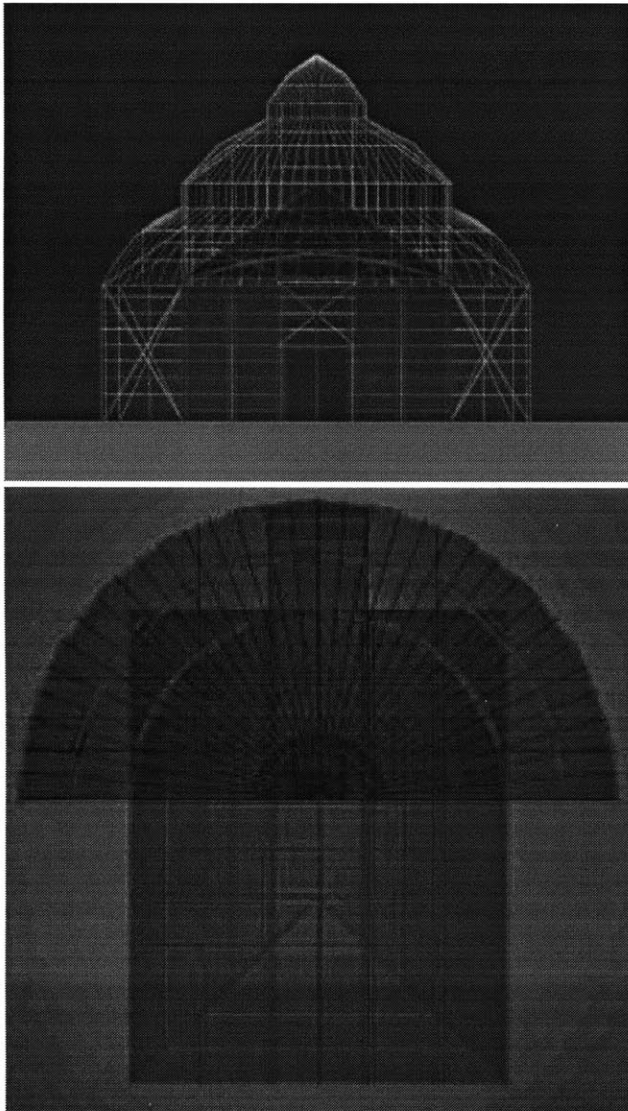

Figure 14: Plan and Front Elevation of a *Puja Pandal*. What is required to make this tradition into an "Industry" of temporary construction?

3. A Large Span Temporary Structure in Bamboo – Why?

In recent years there has been some interest in using *Pandals* for broader public congregational structures, but essentially it is still a structure that responds to a specific purpose required of *Pandals* and its use remains tailored to them. This study makes the claim that with certain strategic modifications this system of construction could become better suited to the more generic, large span structures and perhaps *Pandals* themselves. The focus will be on devising a system of joinery that could be used to build these structures. But before that one would need to lay down the advantages and disadvantages such a system might have over existing systems in steel and wood frame.

3.1 Comparison

In the following section I will touch on the reason that make bamboo a suitable material for urban temporary construction and what its failings are. And furthermore which of these failings can be addressed in the specific design purview of this thesis.

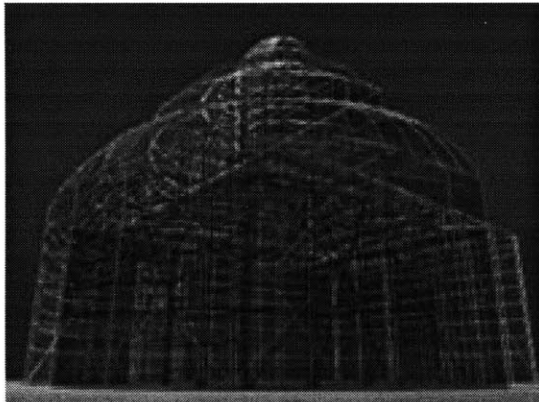

Advantages over existing systems in tubular steel

- Flexibility
- Low weight for comparative sizes
- Sustainable
- Cost Effective
- Less Machinery Dependent (No welding, riveting , bolting etc.)

Disadvantages inherent to Bamboo Construction

- Redundancy
- Joinery is indeterminate
- Fire
- Dimensional variation in structural members
- Absence of a central pool of knowledge about material and properties

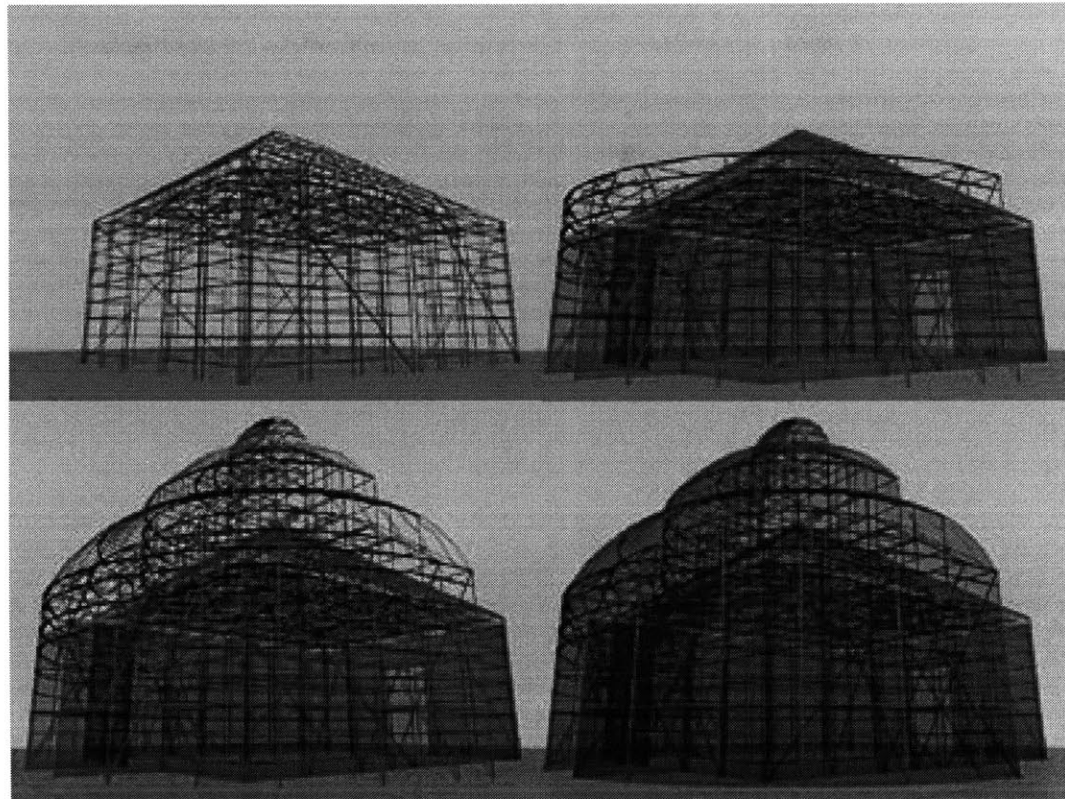

Figure 15: The very process of building *Pandals*, described figuratively in four steps (clockwise from left) is a process that will need to undergo profound change to become a viable system of temporary construction.

Figure 16: A Prototypical Structure: The structure will be approximately 30' on the shorter span and 90' on the longer one. It is based on the "Structural Core" of the Pandal.

Disadvantages that will be addressed by this study in concentrating on the joinery.

- A one-off system of assembly – Introducing a re-useable system
- Adjusting – Post tensioning the structure, during, and after construction
- Skill and craft dependency – making the operation of joinery self-evident
- Over redundancy – Trimming redundancy both in conception and construction
- A "tied" structure, notions associated with it.

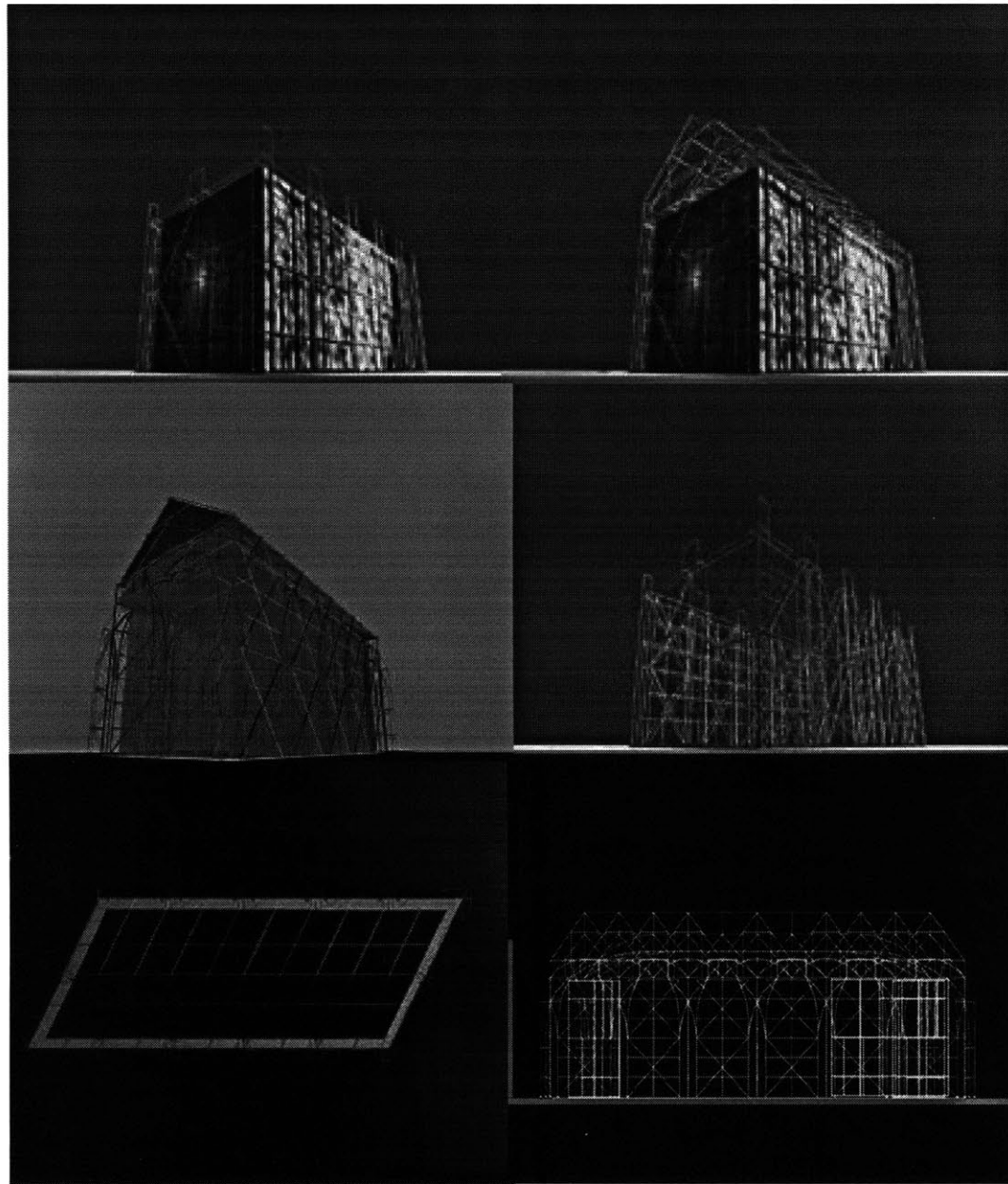

Figure 17: The Plan form demands a repeated non-orthogonal geometry which would be tedious to reproduced with the current method of assembling Pandals based as it is on the approximation of the craftsman.

3.2 Joinery

I will concentrate on joinery to address some of these issues touched upon above and examine briefly what the ramifications of altering the joinery would be. In the realm of bamboo joinery, particularly in the context of these urban structures, there is a lack of a formal set of details or parts that are specific to these structures. This is something that gives the structure its vitality, its ability to be so flexible and also to be constructed with little or no investment. What this study shares with some previous efforts like Frei Otto's is the introduction of a formal set of "elements" for building in bamboo. This has implications that are both positive and negative. The structure is not built from basic "raw" material but it is made with a more "finished" set of parts. The success of this effort will lie in judging the effort it takes to make and introduce a customized part against the gains that accrue from such a design. Moreover the idea is not to replace an entire system of bamboo construction but to offer an alternative - An alternative that is based on building these structure with the intention of introducing a degree of change in terms of design, skill and assembly. That means in the course of the building if the need for another type of joint is felt there might be a possibility.

Structurally scaffoldings and *Pandals* are different structures even though both are made in bamboo with much the same technology, the question is if aspects of either structure should reflect that. Scaffoldings are connected to buildings – that is where they derive their support from – *Pandals* on the other hand are free standing, self supporting, structures, they need to be stable on their own. *Pandals* do this by using more bamboo than might be specifically required to carry load – more bamboo for more stiffness – This is in the form of more cross-bracing, smaller center-to-center distance for the loads. This is not to imply that a structure can be made without cross-bracing but it is to define a detail, a method of joinery, by which the joints could be made stiffer such that their cumulative stiffness would stabilize the structure as a whole. The quantity of bamboo used to build *Pandals* can be reduced if it could be made stiffer by another mechanism - This is an inference that this studies takes as its starting point.

Much like the types of structures the joint, presented in detail in the following sections, is a design that will

require a capital investment to be produced. The nature of the bamboo industry, a fringe economy that has just gained popularity, is decentralized, where small players get contracts on a yearly basis. This lack of centralization has led to low capital investment in issues that relate to technology and innovation. But not for long as competition between players increase along with other competing technologies there will be the need for a greater focus on an assembly approach rather than a craft approach as is seen now. And also with the increasing degree of sophistication some of these structures need to negotiate like the introduction of services etc.

The following sections look at how a system of joinery could be introduced into the bamboo industry. Initially with a low investment, enough to be able to build one prototypical structure. And depending upon its success a joint designed for mass production. But before that one more pass over why an enhanced "mechanism" will benefit the incorporation of large structures in bamboo into the mainstream of large congregational structures.

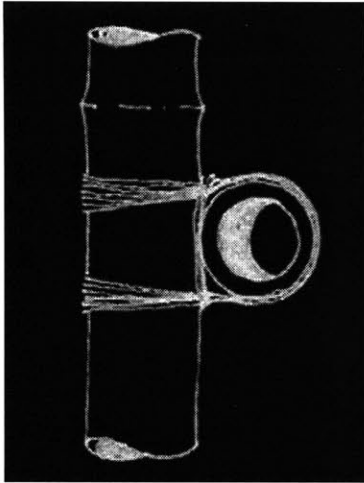

Figure 18: A joint demonstrating the lashing used in bamboo structures. The loop with the cross-lashing to tighten and stiffen the joint.

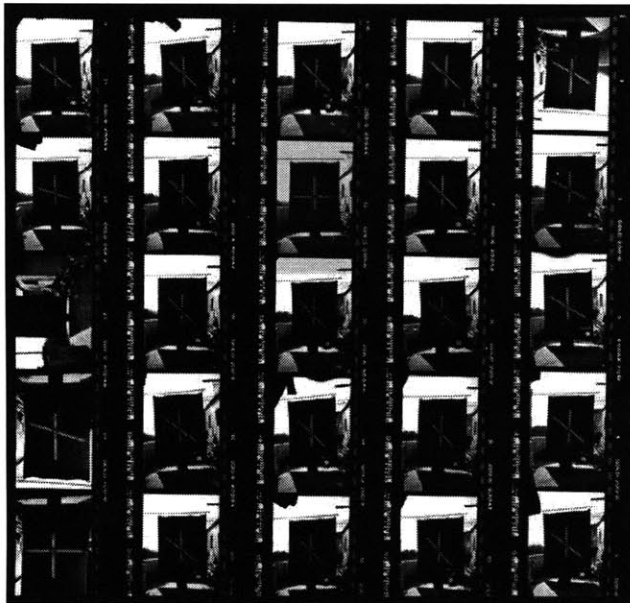

Figure 19: A simple loading experiment demonstrating that the lashed joinery functions like a hinged joint.

4. The Proposed Joint

Bamboo as a material is just gaining legitimacy as a building material. Jules Janssen from the University of Eindhoven has published the first code for bamboo³. This code is not yet a comprehensive code for building and remains restricted to the material itself, there is yet to be a code for building in bamboo that will include issues of joinery and assembly.

The experiment presented as a series of photographs in figure 19 establishes that the joint is a pin-connection. The whole structure is built as a series of pin connections held together by the lashed joinery, the structure is then made stable by introducing additional members. This is the cause for redundancy in bamboo structures. What this implies is that the amount of bamboo used goes beyond just “holding up” the structure, it is required specifically to gain stability. But in the real world loads are far more eccentric, bamboo is curved along its length and outside factors like wind loads and vibrations make it necessary for the structure to be stiffened or stabilized. Scaffoldings are better suited to deal with this condition as they are made stable by being anchored to buildings.

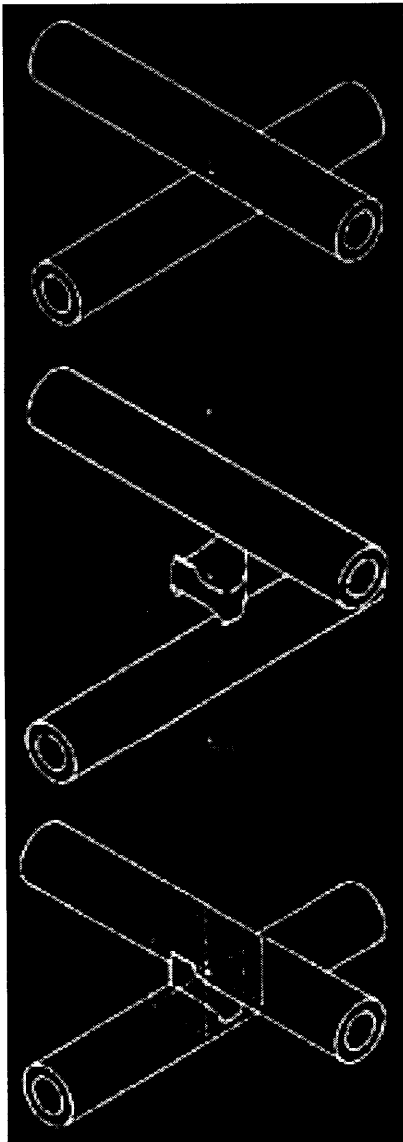

Figure 20: A series of figures showing the contact between two rods and a form that "fills" the negative space rising from that condition.

To reiterate, if one analyzed any lashed joint there is one aspect that comes about after a little deliberation. The contact between two tangential rods is made at a single point and a point is inherently weak. The binding solves this by a loop that takes both rods and pulls them towards each other. After this is done the binding is wrapped across the plane of the wrapping (figure 18) – this serves two purposes 1. It increases the tension in the binding 2. It tries to fill up the gap that is a result of two curved surfaces meeting. The more this gap is filled the more stiff the joint will be. The proposed joint piece does this at the very outset, its form is the negative space between to tangentially touching cylinders (figure 20), what remains is to tie the bamboo to this piece – in a sense squeeze the bearing plate between two rods. The other advantage of this filler is an increased bearing surface, helping both in distributing load and increasing the surface that actually grips the bamboo rod. This is the basic idea for the joint piece – the generic joint. Now building around this block are various techniques of joining or strapping (an aspect of the joint retained for the lashed joint, as it needs no tools)

The joint presented in detail later attempts, to give the structure more stability by incrementally stabilizing each joint. An experiment will make the nature to this stability more clear. A square built by joining four separate poles with a method employed by bamboo workers against a square built by joining with a bearing detail (following page, figure 21). Now as long as there is no play, in other words, as long as the joint dampens the connection the square will be more stable. What does this do to the structure? Consider any **isolated frame** in a structure with greater moment the structure will retain its shape under eccentric loads. This will reduce the need for additional structure to gain stability (cross-bracing, additional vertical/horizontal members) reducing the total number of members in the structure.

Most of these structures move a lot relative to the ground. What the above experiment will also bring home is the ability to tighten joinery fairly easily, so that the structure can be re-tensed or adjusted after it has been built – An ability to tighten the structure to achieve plumb after the structure is complete was one of the needs that came across from the builder.

Bamboo is a cheap material. It costs about \$ 2 to \$ 3 per piece. Cumulatively it is still the most expensive aspect of the structure. The 3000 or so pieces would cost between \$6000 and \$8000. But this is material cost – Considering that the joint could reduce the number of pieces has further implications. The aspect of transport, storage and quality of the bamboo being used will all be effected. Also, less joints will mean less time taken to build, this coupled with the fact that the joint is already faster than the lashed joint to make will mean a greatly reduced time scale. The transelation of these perceived advantages into exact quantitative data falls outside the purview of the study and would form the next stage in the effort to understand just how effective this system could be.

The need for quantitative data is quite telling in that by this process there is a general move towards a “designed” structure in the structural sense. This is in line with certain developments in the development of a building code for bamboo according to size, species, and water content. This coupled with a joint that one could structurally anticipate could provide one with a designed structure – If not every one of them then at least certain standard typologies. But before we get into the joints we should look at what the advantages of introducing a new system of joinery are and why one would even look at bamboo as a material for temporary structures.

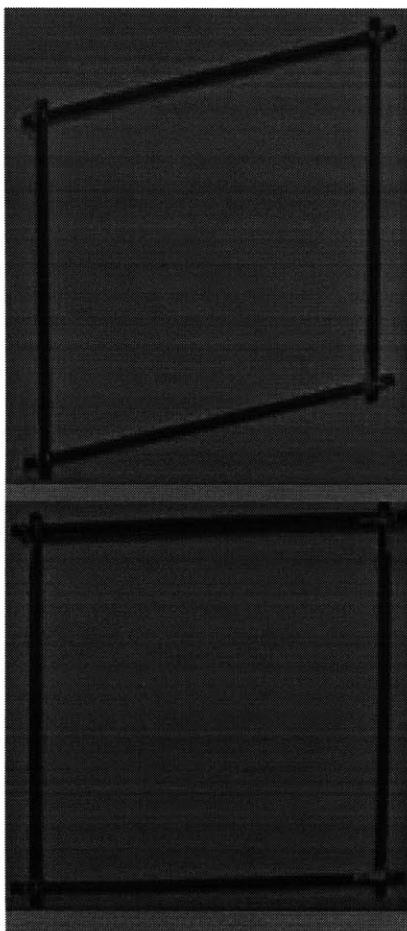

Figure 21: From the top :-
The first image shows the deflection in a square frame made with the lashed joint. In the second image the same frame deflects to a lesser degree under its own weight when the joints are made with the bearing piece.



Figure 22: Close up of the bearing detail used in the frames in figure 21.

4.1 Systems of Economy:

One of the main advantages of bamboo is that it is inexpensive. But by assuming it to be such and using it in a "cheap" manner it is made use of injudiciously. Here the advantages of its being inexpensive tend to get lost in the assumption that any amount of it can be used. There is a need for an economy in the use of bamboo, an economy which is not restricted to just monetary prudence. It is in every aspect of how it relates to the making the structure. For instance, it relates to the quantity of bamboo used in a structure, and to whether this amount can be economized upon by certain strategic design modifications. This economy also relates to the availability of labor and how a certain economy is gained by having, lower skilled, readily available labor. This follows the logic that when a certain skill level is needed for a task then there is also the need for an adequate system of training. This economy also relates to the time taken to build a structure and mechanisms that might be able to reduce this time of assembly. Or the idea that it can be made repeatable without excessive design input for each successive use etc. There are four separate fields of economy that govern the building of the structure, these are an economy in Design, in Material, and in Labor and Build Time and all these have a bearing on the most basic of economies, an economy in Cost. I will take each one separately and briefly examine how they might be addressed by the introduction of the bearing joint both directly and indirectly.

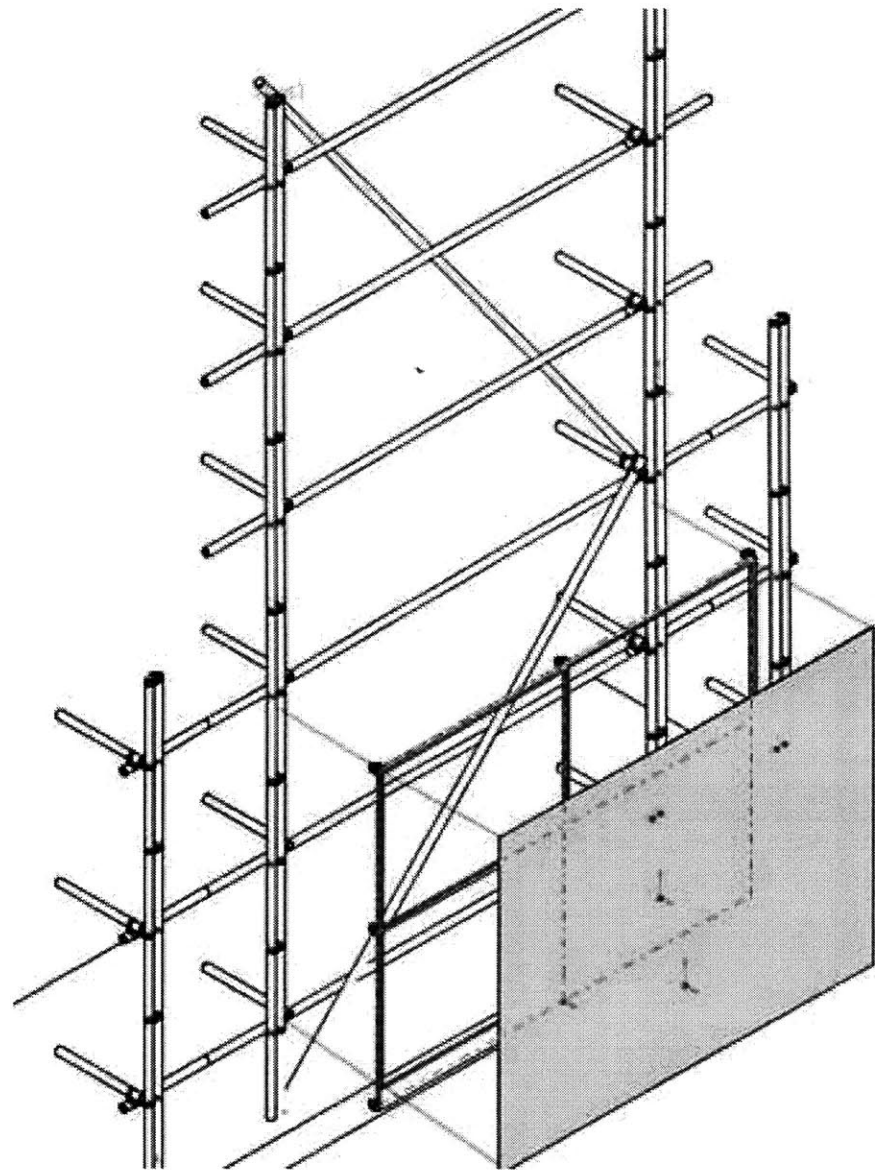

Figure 23: A detail of the structure introduced in section 3.1 demonstrating the attachment of the wood frame and cloth in such a way so as not to damage the bamboo

Economy in Design

In a pre-designed structure the amount of material is known to a degree where it becomes possible to bid competitively for the structure. Also the design will be able to incorporate Utilities like HVAC and electrical, these utilities are necessary for a structure to be built as a serious replacement for contemporary temporary structures. As the structure is built from a few components in complex assemblies it could be possible to use contemporary computational tools in an effective manner.

Using Finite Element Method it could be possible to ascertain the level of redundancy acceptable in a bamboo structure by describing how they function in a virtual sense. What this system presents the designer with is a framework within which to develop a structural model based on the material properties of bamboo and a good idea of the nature of the joint. The model is then analyzed on the basis of this information and a graphical account of the deflection, stress and bending moment are available at the end of an analysis cycle. To be more precise, F.E.M breaks down any structural system or continuum into submembers (such as truss members or in this case individual bamboo culms). Computer algorithms then utilize the spatial information locating these discrete elements and the mechanical properties to assemble a comprehensive model. See Appendix A for more on the use of the Finite Element Analysis in determining the behaviour of an indeterminate structure

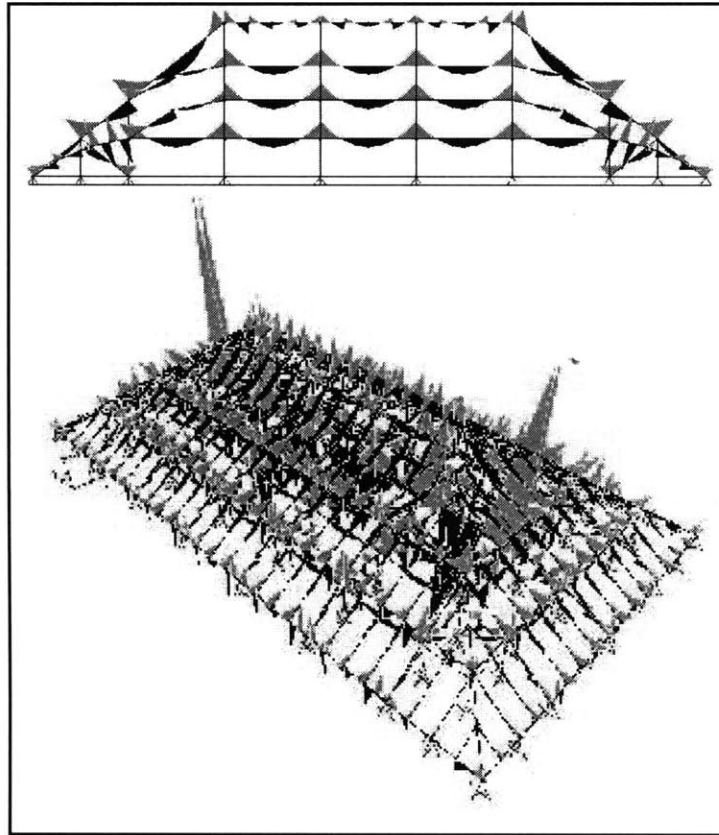

Figure 24: A structural study of the gable roof structure in a *Pandal*. All joints were assumed to be pure hinges and the material properties of the material were sourced from IL-31, ILS, Stuttgart, 1980.

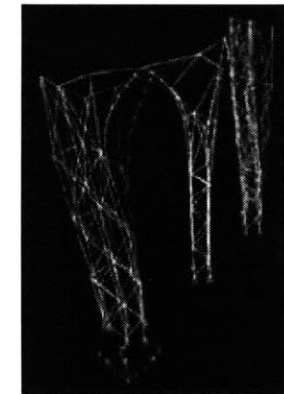
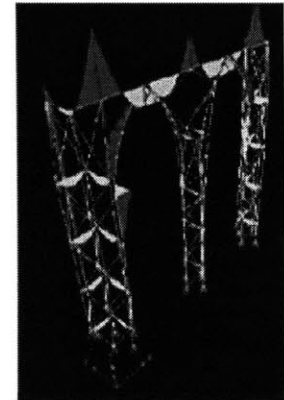
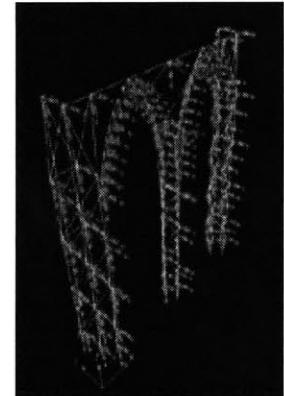

Figure 25: From the top :-Three conditions
- Loading Diagram
- Moment Diagram
- Exaggerated Deflection

It is vital to the Finite Element Method to have an accurate data on material properties and joinery conditions.

Economy in Material

This essentially means using the material in a manner where it is conserved for extended use. Here the material is valued for its quality and its use is based on it rather than its availability. Can for instance bamboo be used in a manner whereby it is not damaged in the course of construction. In the course of building *Pandals* the bamboo tends to get damaged as the wooden frames are nailed to the bamboo splitting them and allowing moisture to penetrate into the fibers.

Economy in Cost

In very simple terms this amounts to the quantity of bamboo used to build the structure. The exact quantity that will be reduced by the introduction of this joint can only be ascertained in practice. What I will consider is a benchmark beyond which the joint becomes economical. Consider that the joint can reduce the amount of bamboo used in a structure by 20% and the total cost of the bamboo in the structure at Rs.100/ piece is Rs.300,000. Just on the material this is a saving of 60,000 (\$1500/-) without considering the costs associated with storage, transport and quality that the remaining pieces will accrue over a few seasons. When this is compared with the amount the joint would cost it is not yet beneficial, as the bearing piece at a cost of Rs.7/- per piece will cost Rs.70,000/-. But the advantage over a material like jute is that it is more durable. Jute needs to be procured each season as it is typically used twice because it rots leading to a loss of strength.

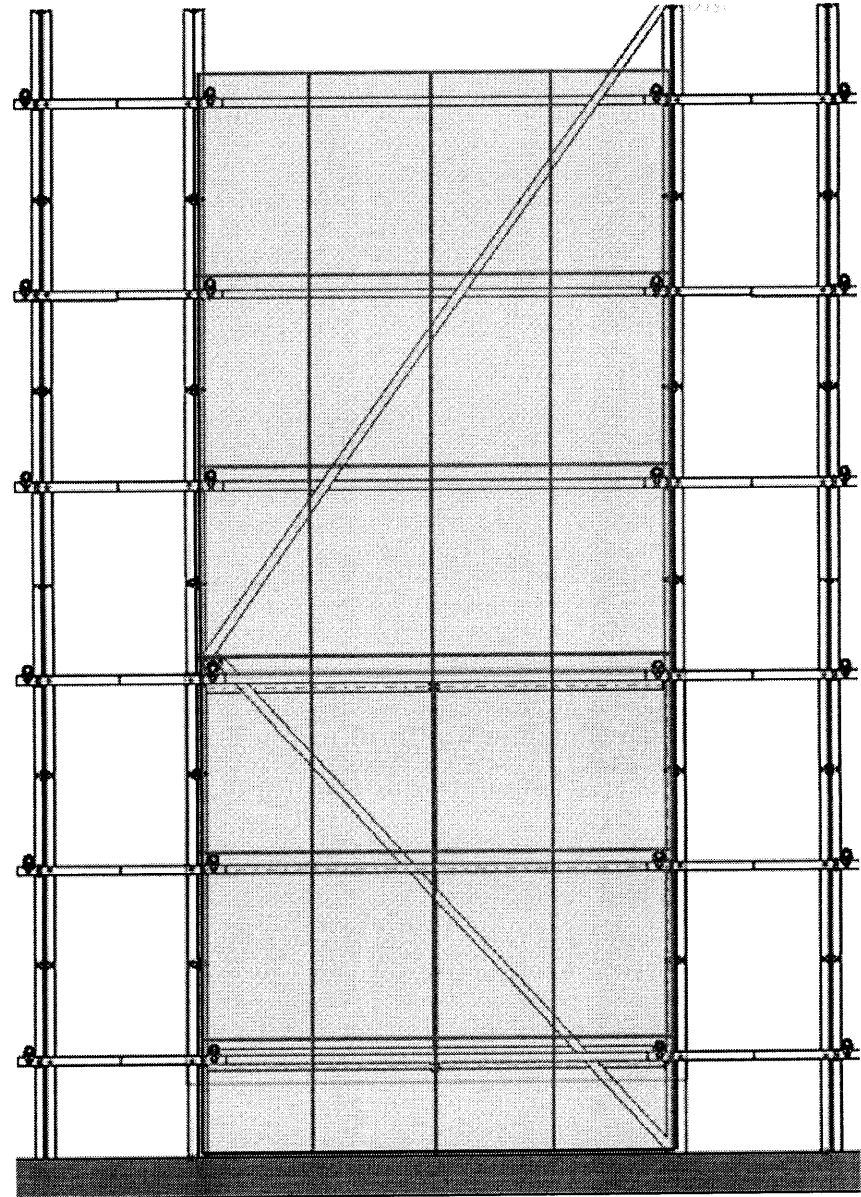

Figure 26: An Economy in Design: A system of assembly where the bamboo is both conserved and protected

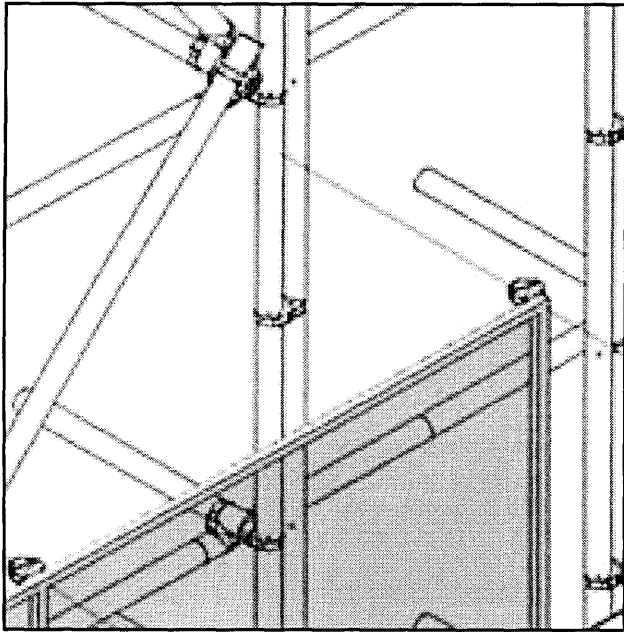

Figure 27: An Economy in Material: Using the bearing detail so that the material is not damaged by the use of nails.

Economy in Labor and Build Time

These structures are built over a very rapid period of a month but with the average workday of about 16 hours. Putting the time of construction up to 2 months if one considered an 8-hour work shift. As an industry this will need to be considered as labor laws and unions do not allow for more than 8-hour shifts. Seen in this light it does not appear so competitive anymore. A lot of this time is spent in joinery – the nature of his operation is time consuming as it is the repeated act of winding a jute cord around an assembly of bamboo held in place by hand to give it bulk and thus some degree of stiffness. This operation can take anywhere between less than a minute (in cases where the bamboo is already in place and just needs to be tied down) to up to five minutes where the joint is complex and repeated lashings are needed to wind around the assembly. Time needs to be reduced in this operation without sacrificing the advantages of flexibility. The bearing joint will take an average of half a minute for simple joints and about a minute or more for complex assemblies, as it needs to be joined to at the most two pieces. As a joint this will have a profound effect on how rapidly the structure can be constructed joint by joint. Considering that there are about 10,000 joints in the structure each taking 1 minute to make this will amount to 6 man-days. The joint has the potential to reduce this by half. Another aspect of the assembly that relates to the time of construction is that it is built piece by piece, one pole after another. Some form of pre-fabrication could mean multiple sites of operation and greatly reduced time. The bearing joint could allow this by the pre-assembly of parts on the ground to be hoisted into place by making a section of the *Pandal* on ground level. Moreover here decisions about dimensions and placements are made on the ground and the workers' task is limited to making small adjustments before completing the operation. This is in comparison with a situation now where the whole structure is built piece by piece attached on the structure with a common ambiguity about where the joint needs to be exactly attached. Also, During the process of construction some joints get loose and need to be re-tensed – This is one of the aspects that a lot of time is spent on. Going back to specific joint, tightening them to return the structure to plumb. And because joints are wrapped this can be very complicated. By a simple strap this ability to adjust or post tense the structure, is made simpler.

Finally, in most contemporary methods of manufacture the knowledge of a task or an overall picture is central-

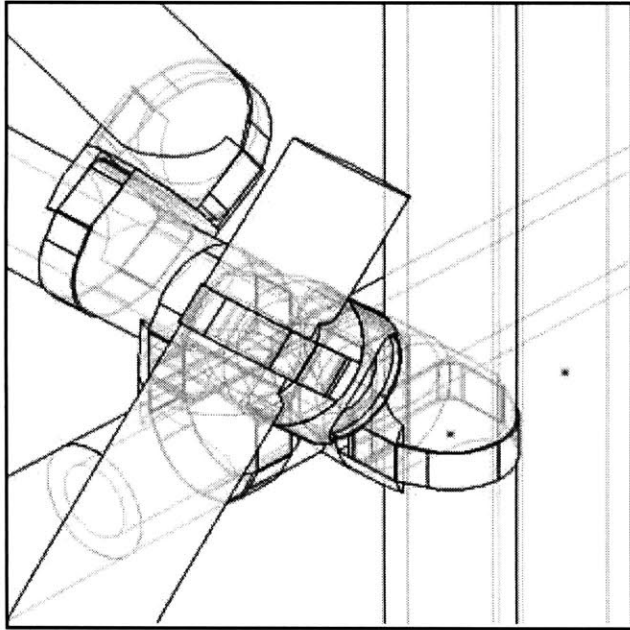

Figure 28: An Economy in Labor and Build Time: A joint that takes less time to assemble and can be adjusted during the course of construction. Figure 20: A series of figures showing the contact between two rods and a form that "fills" the negative space rising from that condition.

ized in the person of the leader or builder. The worker is involved in a low skill task that is pre-established and relatively easy to perform. This is different from a craft based setup like the *Pandal* industry, where all the skills and some knowledge of the tasks are still located in the worker. This makes for some of the special characteristic of the structure but not its ability to be built and rebuilt. In the proposed joint the joinery is a simple act of tying or lashing, a lower skill activity that can be repeated with the same result each time. All the preceding factors – lesser material, lower skilled labor, per-fabrication will lend to the structure one characteristic that is not needed of it now – repeatability. They make the structure competitive as a generic temporary structure by providing some of the mechanisms by which it can be made again and again with little or no design input.

4.2 The Bearing Piece

When one seeks to alter an existing system of belief, mode of thought or practice the first step is to ascertain what it is that is exemplary about it and should be retained and what could do with change. Off course this would be a subjective assessment but it would provide to the outside observer "an angle of attack".

Pandals are very successful structures for the specific purpose for which they are built. They have evolved in a somewhat evolutionary manner by accepting the "lowest common denominator" as a function of the materials, the costs, the manpower and time needed to construct them. But to enable this they have remained limited to a few individuals who, up until the recent past, were making it for a specific purpose.

It has to do with an issue of skilled manpower, this knowledge about lashing (tying poles of bamboo as a system of joinery) is somewhat of a black art. Most joinery is a complex pattern of knotting – so complex that often the strict patterns are not followed even for making pandals. As a result when the joinery gets complex it begins to resemble a jumble. Jute is just used to 'beef up' the joint. That an intervention is necessary is still arguable at this stage. The only arena where that would be answered is that of practice – any innovation after all has to become successful there for it to be valid. This study takes that approach – the course of this investigation is an

intermediate stage. The results from here will finally be tested "on site".

Any intervention could follow two basic paths. One would accept the system in place (lashing) as is but develop on the patterns of lashing, improve on the material used and ensure its proper use – this I will call the "Pattern Book Approach". The scaffolding industry in Hong Kong follows this approach. For scaffoldings this seems the correct path of choice but for free standing structures the joinery needs to do more than just bring two members together. The other path would be to introduce a formal joint or a part that aids or completely replaces the concept of lashing – this I will call the "Kit of Parts Approach". The later intervention could potentially have larger ramifications on how the structure might be constructed as something "new" is introduced into the scheme of things. This approach is also more radical in terms of alteration and some choices about the degree of alteration will need to be made at the outset. These choices will be about whether tools should be introduced in the process of construction or if a part is being introduced how many variations of that part should make up the kit. When in other words does it become too complex to sustain? These are questions that could be somewhat answered here. But it would be fair to say that arriving at the correct number of parts (3 against 9 say) would be superfluous in the somewhat rarefied air of this study. The opportunity here is to make a series of parts that could go together in some manner, have specific advantages over others, but the choice of what actually finds success in practice be left to natural selection in the course of their use in practice. What does not suit the context of the work will be rejected in and of it self. This is the how pandals have been made and it seems the best way.

To clarify – The intention is not to make as many options as possible but to focus on a few options. These options are like choices, one choice is not to introduce tools that would need to be carried around by the worker into the operation. What this does is precludes the type of bolted joint one sees in many scaffolding details which require spanners or pliers. The other choice is not to impinge upon the structural integrity of the bamboo no cuts, splays etc. Not only would they require tools but they would also make the bamboo rod redundant after one use. I have tried to describe what the joint is not. Now I will say what the joint is. –

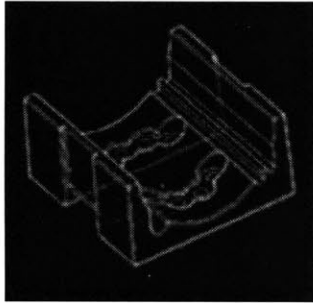

Figure 29: A orthogonal form for the bearing piece allows a joint with larger surface contact, allowing a stiffer connection.

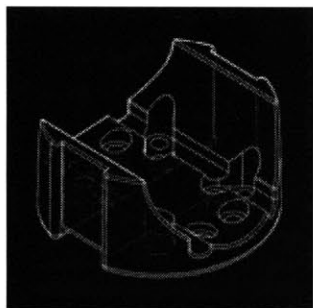

Figure 30: A circular form allows for less contact, but is more negotiable in situations where more complex joinery is required

The Various Joints

The initial investigation about the structure involved a detail that sought to study joinery from older scaffolding details. Most of these systems are based on a hinge with a bolted connection. This works well for Steel scaffolding rods where one does not deal with dimensional variation in the cross-section. Also, most require some form of tools that the worker needed to carry. This is rare in the act of building in bamboo – tools and their use might become prevalent at one stage with the change in the very technology of building but at this point it a conscious choice not use any tools in the process of assembling the structure. From the case of the Pandal under study it seems that a joint that can negotiate a cross-sectional variation in dimension of about of ½” would ensure that all bamboo poles be used.

This need for a dimensional tolerance of ½” was pointing to a direction that did essentially what a lashing did but with a mechanism that re-configured the “act of tying” to an “act of snapping or clicking”. So a strap or a band with a mechanism like a clip or buckle at one end would work for this. What these gave the structure was perhaps a quicker assembly but does not solve the degree of complexity that is needed to obtain a working joint – it is not yet a clean. With the introduction of the bearing piece the joinery would perhaps become quicker and stronger. Listed below are some of the criteria that were used to ascertain the appropriate elements in the joint.

Is the bearing piece a square or circular in plan?

- The square piece will be more effective in preventing rotation
- The square piece will allow cuts and splays to be used for lashing
- The orthogonal surface could be a bearing surface for other attachments.
- The circular piece has lesser material thus is cheaper.
- A smaller size allow for a better fit in a joint of many pieces.
- Complex geometries could allow for more interlock.

Is it Rubber, Wood, Plastic, Aluminum or Bamboo -

- Plastic could be injection molded for a cheap joint.
- Rubber is more flexible
- Wood is most expensive in terms of production.
- Bamboo, but it will not be flexible enough.
- Aluminum is a cheap metal that could be cast fairly easily; it would also be stiff. The issue here is if it might be too rigid.

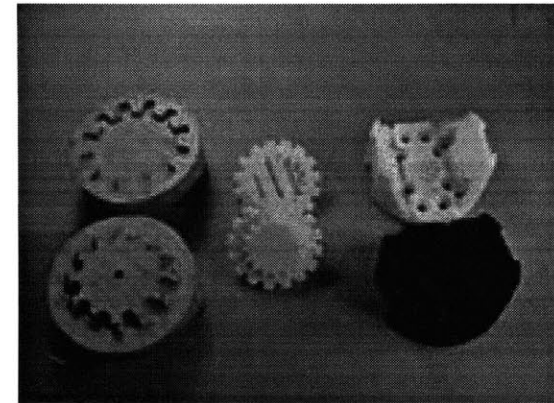

Figure 31: Prototypes of the bearing piece in wood, plastic, epoxy and rubber

Continuous Strap Vs Discontinuous Strap

- The Continuous strap is one operation that requires only one closing detail.
- The Discontinuous strap has the advantage of a separate operation to receive the second piece of bamboo. Operationally this is better – as once all the receiving blocks are in place the bamboo just needs to be attached. Someone performs the first operation on the ground and the second by someone on the structure. It will have better tension in it as a smaller length is being pulled together.

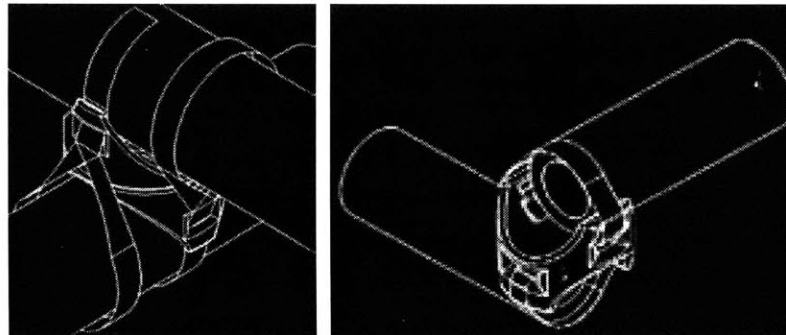

Figure 32: From the left - A "continuous" strapping and a "discontinuous strapping."

What is the closing mechanism?

- **With rope or chord** it would be essentially the same joint with a bearing plate between the two members. The sailing industry will have possible end fixtures for joinery using rope or chord. The

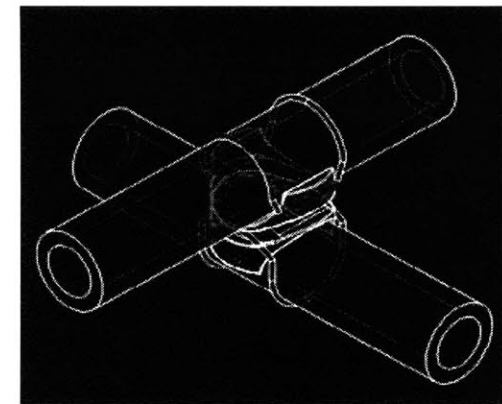

Figure 33: A connection retaining some form of rope or chord as the closing mechanism.

questions are - What is the appropriate thickness of the rope/cord? - Will one cord of sufficient thickness be enough or does one need to have a series of ropes not unlike the bamboo structure? What material, one too elastic will not be stable?

- **A nylon/cotton strap** is the next step and better as possibly here the strap acts like a bearing surface on the bamboo. The closing mechanisms are like buckles and ratchet ends with a synched locking mechanism. The block will need to be thicker to accommodate the strap if it needs to travel through it.
- **A plastic piece** like a reusable ratchet can be both detached and attached from the piece. The advantage of a detached piece is that its life span is not connected to that of the piece. The advantage of a connected piece is the reduction of number of parts. And if the piece is sufficiently thick, the possibility of a "click shut" mechanism, something that clamps the two pieces together. Here the possibility of an integral ratchet mechanism could be explored.

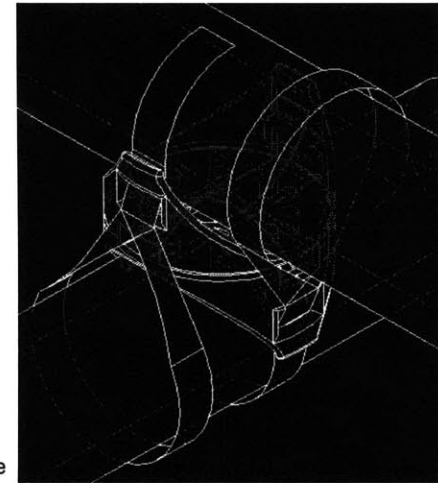

Figure 34: A strapping in nylon through the "body" of the piece

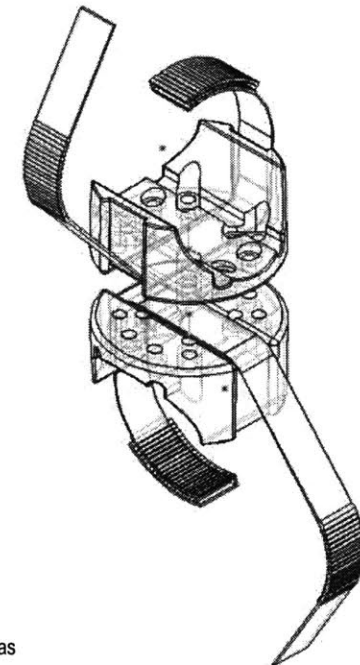

Figure 35: An assembly that makes use of a reusable ratchet as a closing mechanism.

Design Development: Bearing Piece

There is a practice of using a detail similar to the bearing piece in building Puja Pandals. It is essentially a small section of a larger diameter bamboo rod that is cut above and below the rib they are used in specific conditions where a little stiffness is needed. The problem is that they themselves are dimensionally intolerant and can split quite easily. The first diagram in figure 36 shows a simple bearing block with grooves in it to incorporate lashing. Here the piece could be attached to one piece, pre-assembled, and hoisted into place to be attached to another piece. The next joint incorporated the idea of substituting the binding or lashing for a strap in a material like nylon with a mechanism like a buckle at one end. This would be tightened by a synching action on the buckle. The second diagram in figure 36 shows the buckle incorporated into the body of the bearing piece. All these solutions pertain to a singular condition – the orthogonal joint. Now even though about 90 % of the joints start of being orthogonal (that is very few pieces make their first connections at an angle like two cross-bracing pieces) there is a need for a joint that can allow sufficient degrees of angular variation. The first design in this regard was a two part piece in plastic that had a set of male and female gears, this design incorporated a lip that became a hold around which the a lashing could be made. Two problems – 1. The lashing would need to be very strong to keep the joint operational and 2. The joint now has 4 distinct parts that need to be negotiated. The third diagram shows a detail where instead of gears to establish angles a con-

	Production	Operation	Degree Flexibility	Degree of Stiffness	Number of Parts	End-Cost	Pre-Assembly
	Very High	Tension & Compression	0	Moderate	2	High	No
	High	Tension & Compression	0	Very High	3	Low	Yes
	Low	Tension	8	Moderate	12	Low	Yes
	Moderate	Compression	8	High	4	Low	Yes

Figure 36: A comparative analysis of four main bearing details through the stages of design development. The diagrams are referred to from the top as diagram 1

figuration of bolts is used. The joints can be pre-set to an angle on the ground, bolted through to join the pieces, and made up to the desired number and variation so if one needs 6000 pieces of orthogonal joints they will be fabricated on the ground prior to making the structure. Then the pieces can be used as desired. The need was now to eliminate the complexity involved with using the joint to do its task (see "number of parts" in figure 36").

The final solution does this with certain allowances, diagram 4, figure 36. The pieces will be in two parts, which will have a one bolthole as shown, and a scheme of gears taken from some earlier design, this allows the possibility of variable angles. The strapping will be incorporated by removing excess material from the webs. The orthogonal joint and all angles require two pieces. This has a bearing on the many issues. 1. The number of pieces of casting or molding goes down by half compared to the last joint bringing the cost of the piece down. 2. The joint can be assembled on a piece with exact dimensions and the other pieces could just be put in place. 3. Two types of joinery become possible a simpler quicker version and a more complex version. 4. The number of parts is reduced considerably.

4.3 Material and Production

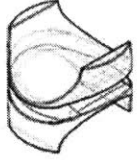
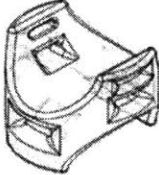
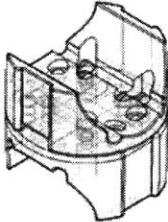
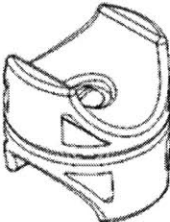
The material used in this joint will need to have a degree of flexibility. This flexibility is needed to accommodate the dimensional varia-

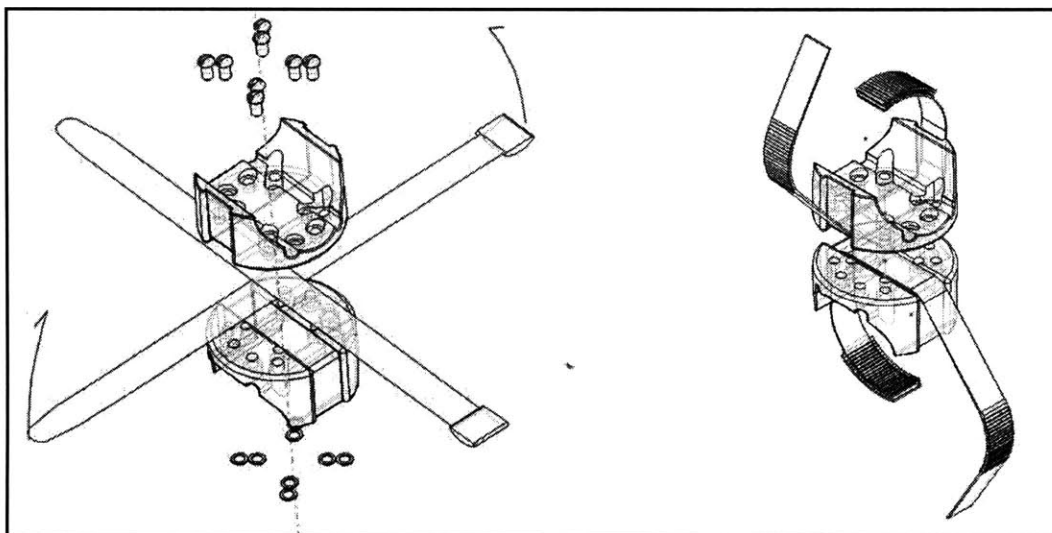
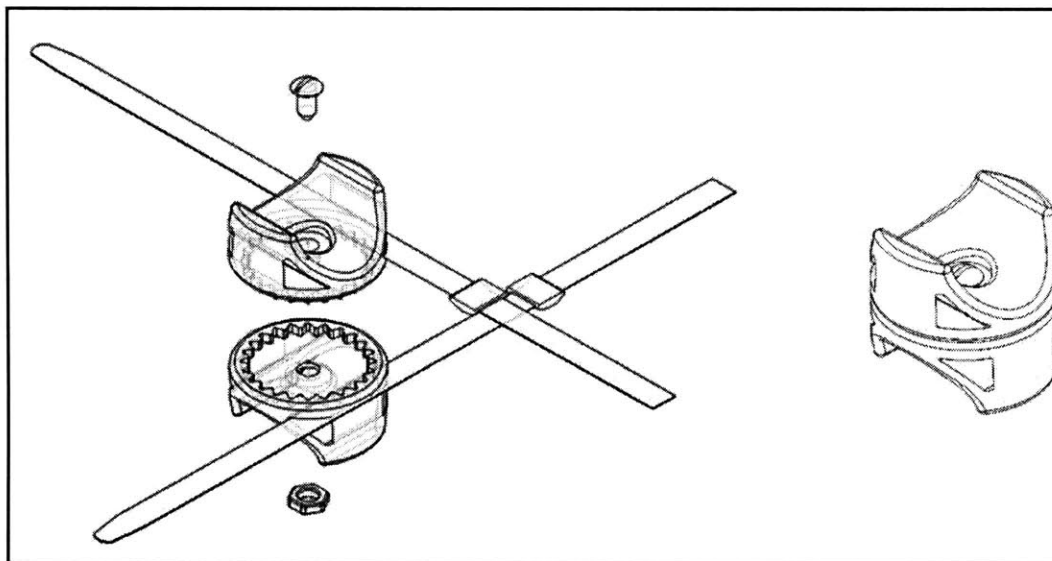

Figure 37 (above): A joint detail adjustable to eight distinct angular settings. 12 parts make it high on assembly and low on manufacture

Figure 38 (below): A geared mate allows 12 distinct settings. Lower part count and the parts can be readjusted fairly easily.



tion within and among bamboo poles. A natural material like bamboo does not have the ability to flex in a small form without splitting along its fibers. An industrial material like rubber or plastic seems ideally suited to this function.

The question of whether it is appropriate to introduce an industrial material bears some thought. Most materials do not need to answer to these questions but bamboo's study has made these questions imperative. This study takes the viewpoint that if the use of a certain, industrial product, furthers the use of bamboo itself it then it is beneficial to bamboo and justified to use it.

The hardness, flexibility and resilience and cost of materials like soft plastic and hard rubbers were systematically investigated and through trial and error the correct value for the hardness and flexibility was arrived at (figure 39). Plastic tend to be quite hard for the specific purpose of a "dampner" and rubbers tend to be too soft. There is also a quality in the nature of the flexibility, plastic will tend to compress where as Rubber is essentially an incompressible substance that deflects by changing shape rather than volume. These properties have a bearing on how rigid the bearing piece will be and thus how efficient a dampening mechanism.

The process followed here was a classic method of prototyping small parts in plastic and rubber (figure 41). The first step is to make a 3-d print of the designed joint. This 3-D print is then used

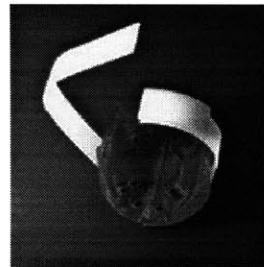

Figure 40: The final joint in conjunction with the ratchet strap

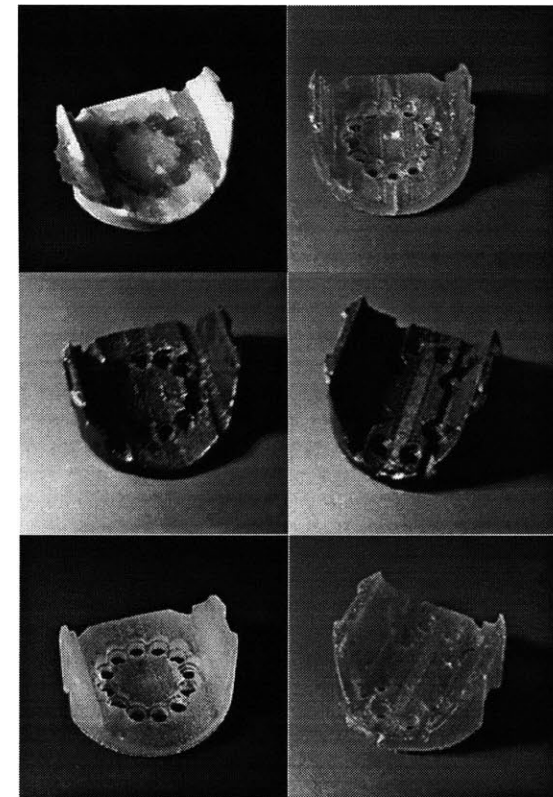

Figure 39: A series of cast exploring the material properties of various materials. From top, left, counter clockwise :-
 - A plastic, Durometer -75, too hard and brittle
 - An epoxy, Durometer --20, too soft and non-resilient
 - A rubber, Shore A - 75, too soft and flexible
 - A rubber, Durometer 45, good flexibility, weak form
 - An epoxy, Durometer 60, correct form, too hard.
 - A rubber, Durometer 55, final chosen form and material

to make a mold with a soft compound like rubber (two separate resins are poured into a vessel holding the 3-D model and after a curing process a negative of the piece is produced. This now becomes the vessel or mold into which various compounds can be poured that produce final casts that might vary in flexibility and hardness. The images show the mold and the various cast produced for this procedure. There is a feedback loop here and the results of this casting are fed back into the process to make another cast. In this case it was found that the joint will need to be made larger as the joint was either too flexible or too rigid. Also the correct hardness was not being achieved by regular resin products. Eventually a special rubber resin was chosen which had a hardness value in the lower plastic range – This was a Durometer reading of 55. This would be approximately twice as hard as tire rubber (figure 39).

The final production has a bearing on the two chosen parts. The first part is a low production part. The intention here is to economically produce a small quantity of parts, up to 10, 000, and in a manner that could be undertaken by a small operator in Delhi or Calcutta. The process of production will be plastic casting – very much like other forms of casting were by plastic is poured in a Aluminum or Stainless Steel mold and removed after the curing process (following page, figure 43) . This piece is ideally suited to this form of production as it does not have any under-cuts that might require expensive tooling. The other process suited to this

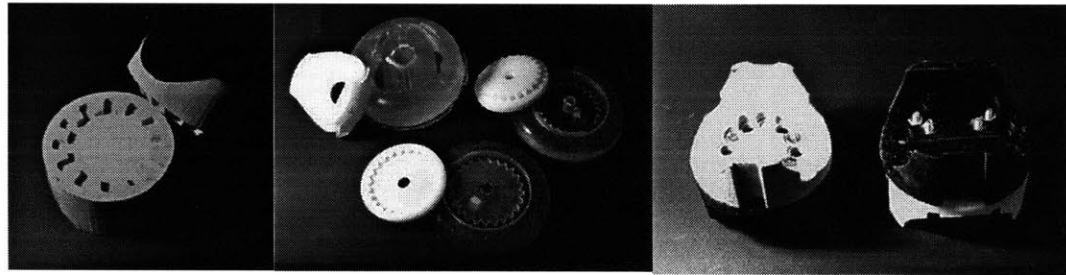

Figure 41: The prototyping process: The rough model in wood the 3D printed models used to make castings and the final joints in a combination of materials

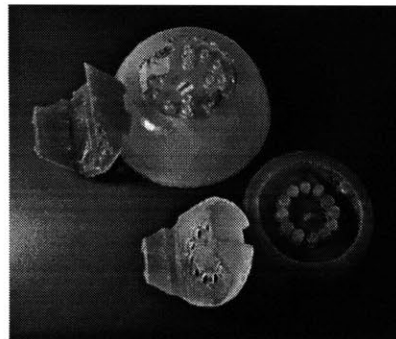

Figure 42: The two main moldseach were used to produce ~ 20cast s for various materials shown in figure 39.

piece is Roto-molding a common process for large parts in plastic like garbage cans and containers but also suited to small parts like this joint. Here again the advantage is that there are no undercuts in the form. The other cost-reducing feature of this part is the need to manufacture just one piece that can be used in conjunction with its mirror image. The disadvantage of this joint, as mentioned earlier, is the high part count per finished joint. The need to bolt the connection as a form of assembly is a tedious operation but is a pay off for a cheap part.

Once the need to produce about 100,000 parts is felt then they can be injection molded and a part more suited to assembly can be produced (following page, figure 45). This joint has two separate pieces that require two separate molds, effectively reducing the number of parts produced per mold by half, increasing costs. Also the tool for this part will need to accommodate undercuts and will thus be expensive but the end part cost will be much less compared to the former mechanism as once the tool is produced the entire process is mechanized.

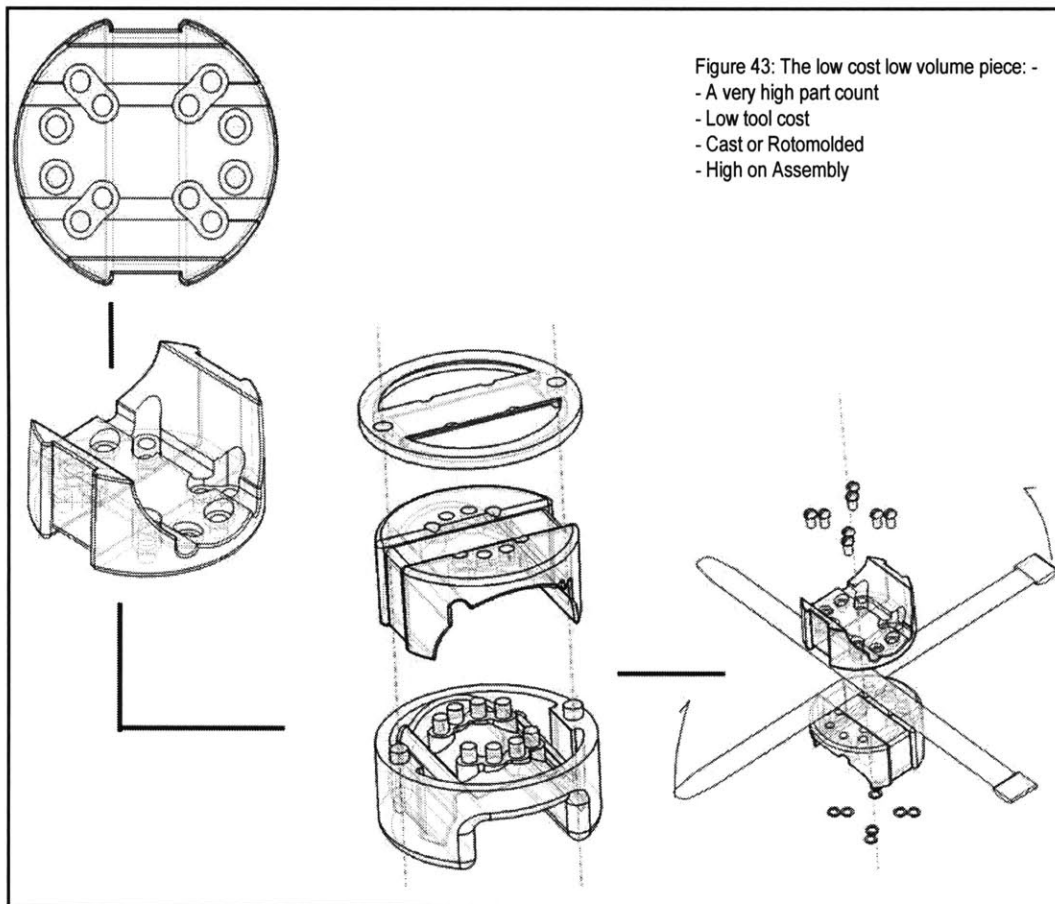

Figure 43: The low cost low volume piece: -
 - A very high part count
 - Low tool cost
 - Cast or Rotomolded
 - High on Assembly

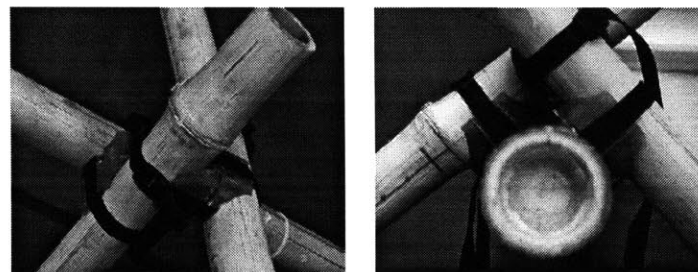

Figure 44: A working prototype of the joint used in an assembly of three mutually perpendicular pieces. This joint required three separate couples of the bearing piece.

³ Jules Janssen, University of Eindhoven, 1999.

4.4 Conclusion

There have been two paths of inquiry in the study. The first has looked at bamboo as a material with a unique tradition and practice of building; a practice of building that is particular to cities in the Third World. This has been looked at with the help of a case study – *Puja Pandals*. The intention of this inquiry was to identify what change, if any, the practice of buildings *Puja Pandals*, and temporary bamboo structures in general, could under go. After this inquiry was completed the second path began with the identification of a single aspect of bamboo structures that could be beneficially altered - joinery. The design task, and the last stage, was to develop an alternative system of joinery and identify what the potential benefits were.

The study has limited its purview to this stage of identification of benefits. To ascertain further what and how beneficial the results of this inquiry are one would need to construct a prototypical structure so that many of the issues encountered in the course of this study could be engaged in better detail. And the result of this design inquiry has been laying out the methodology to produce the number of joints required to build this prototypical structure in the most cost effective manner

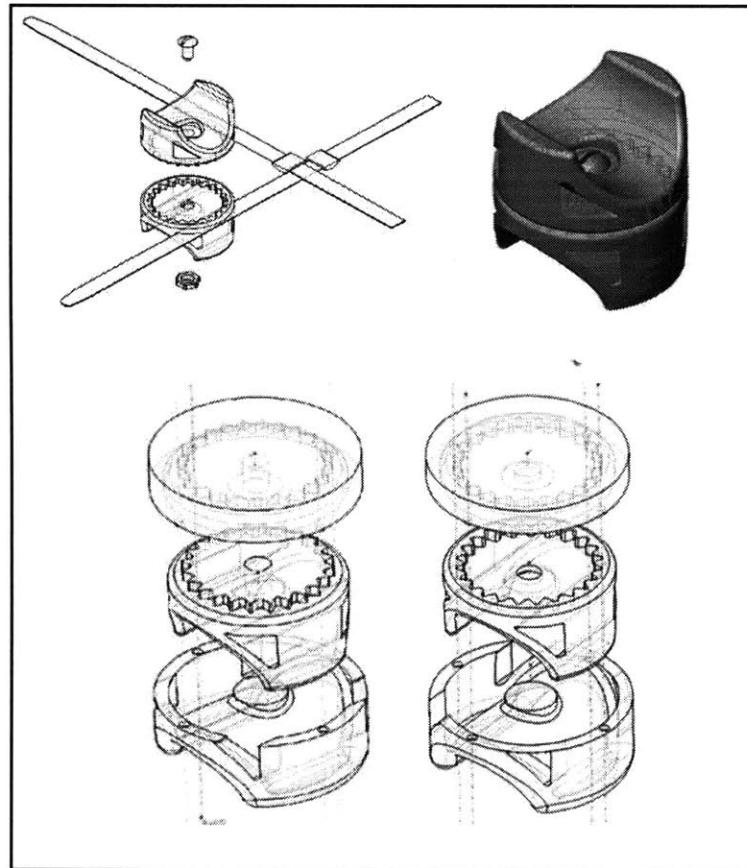

Figure 45: High Volume, High Cost production : -
- Part count reduced by half
- High tool cost
- Cast or Injection molded
- Low on Assembly
- Easier in operation.

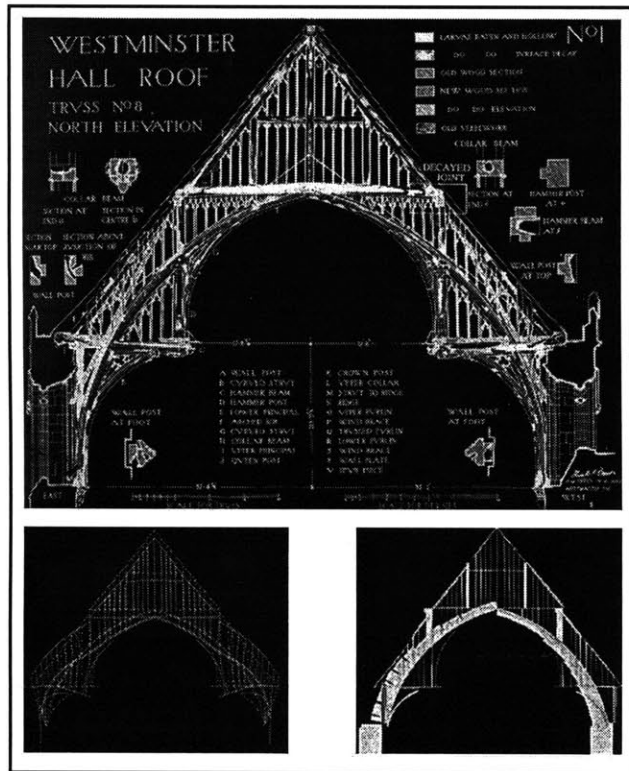

Figure 46: The West Minister Abbey, Clockwise from top -
 - A section through the roof of the Abbey
 - A diagram of axial loads through members (the smaller members are not loaded to a degree that was previously assumed)
 - A diagram of exaggerated deflections

Appendix A

Finite Element Analysis to understand the structural behaviour of an indeterminate structure

This is a method of structural analysis first developed by Ritz in 1909. Because of its reliance on high computational power it did not gain currency until computers became pervasive in the 1980s. It is an effective analytical technique to generate reliable results on structures that exhibit a high degree of complexity as long as an accurate representation of the material properties and the nature of joints is presented. Its main advantage over previous methods is that it avoids a high degree of simplification.[#]

Until recently structures in wood were also defined by the same mentality that characterizes the bamboo industry today. Yet by the 13th century one of the masterpieces of timber construction, The Westminster Abbey, had already been built. And as was the case with the building industry also, abstract data and the science of statics only came into play in the 19th century.

At the time the West-Minster Abbey was built structural redundancy was a major feature in wood construction as well. Until recently methods of structural analysis which tried to demonstrate the dynamics of this structure tended to over-simplify it. The results presented a lean structure which falsified the true nature of how this wood frame functioned with all its redundancies and inaccuracies. It was not until the application of the finite element analysis method that redundancy in the structure was calculated and true picture of how the structure operated came about. This study showed that the wood tracery inset into the major structural elements, that earlier methods tended to ignore, were infact responsible for carrying load and the large brackets supporting on of the composite arches was relatively redundant. This is one among other examples which demonstrates that today finite element analysis is a viable method to analyze structures with a high degree of redundancies in real time.^{*}

[#]Morris & Tobriner, Report on the Application of Finite Element Analysis to Historic Structures, Journal of The Society of Architectural Historians, Sept. 1995, pg 336-347.

^{*}R.D.Cook, Concepts and Applications of Finite Element Analysis, 1989, pg. 6-11. The software used for this analysis was SAP-90TM, EdwardWilson and Ashraf Habibullah, 1991.

Bibliography

Bambus, Klaus Dunkleberg, 1985

IL 31 Bambus – Bamboo, Institute of Lightweight Structures, Stuttgart, 1992

Bamboo, Research at the Eindhoven University of Technology, Dr. Jules Janssen, 1993

Bending Strength of *Guadua* Bamboo: Comparison of Different Testing Procedures, INBAR , 1994

Hong Kong Bamboos, Hong Kong Urban Council Publication, Paul Piu-Hay, 1985

Industrial Raw Materials of Plant Origin: A survey of bamboos, **H.H. Sineath, 1953**

Laboratory Manual on Testing of Bamboo for Determination of Mechanical Properties, Dr. Jules Janssen, 1998

The Book of Bamboo, David Farrelly, 1938

Plastics, John DuBois, 1981

Plastics for Architects and Builders, Albert G.H.Dietz, 1969

Art and Architecture, Ancient and Modern, Research in Philosophy and Technology, Ronald Bruzina Ed., 1982

Calcutta the Living City, Volume 1 & 2, N.N.Das, 1982.

Figure and Photograph Credits

- Figure 03, IL 31, Institute of lightweight Structures, Stuttgart, p. 30

- Figure 04, *ibid.*

- Figure 05, *Bamboo*, Research at the Eindhoven University of Technology, Dr. Jules Janssen, 1993, p. 2

- Figure 06, Figure 07, Figure 08, Figure 09, Figure 10, <http://www.hkta.org>

- Figure 46, Morris & Tobriner, Report on the Application of Finite Element Analysis to Historic Structures, Journal of The Society of Architectural Historians, Sept.1995, p. 337.

All photographs, figures and drawings not mentioned above were done by the autor