

SHIP SYNTHESIS MODEL FOR
NAVAL SURFACE SHIPS

by

MICHAEL ROBERT REED

Lieutenant, United States Navy

B.S., Iowa State University

1969

SUBMITTED IN PARTIAL FULFILLMENT

OF THE REQUIREMENTS FOR THE

DEGREE OF OCEAN ENGINEER

and

THE DEGREE OF MASTER OF SCIENCE

IN NAVAL ARCHITECTURE AND MARINE ENGINEERING

at the

MASSACHUSETTS INSTITUTE OF

TECHNOLOGY

May, 1976

Signature of Author.....
Department of Ocean Engineering

76

Certified by.....
Thesis Supervisor

Accepted by.....
Chairman, Departmental
Committee



ABSTRACT

Ship Synthesis Model for Naval Surface Ships

by: Michael Robert Reed

Submitted to the Department of Ocean Engineering on May 7, 1976, in partial fulfillment of the requirements for the degree of Ocean Engineer and the degree of Master of Science in Naval Architecture and Marine Engineering

This thesis presents a method for estimating the weight, volume, center of gravity, electric load, and other overall ship characteristics of conceptual as well as existing Naval surface displacement ships. The method is computerized and thus permits rapid calculations of technical characteristics for a much larger number of ship studies than would be permitted by hand calculations. The final program listing is given together with a listing of the empirical relations developed.

The program is applicable to Naval surface displacement ships and has been verified to give accurate results for ships which range in size from 300 to 700 feet in length and 1700 to 17,000 tons in displacement.

The model has been found to have applications in conducting feasibility studies, systems analyses, updating design predictions, and conducting comparative studies. However, due to the aggregation of empirical data, the model should not be used as a substitute for preliminary design studies and should definitely not be used for actual ship design.

The program developed is an attempt to provide a more versatile synthesis model for Naval combatants. The versatility is provided by estimating the characteristics of the ship at a greater level of detail than is generally attempted with a synthesis model and by use of a large input array to override calculated values when desired. The model estimates only technical characteristics and no cost estimations are made.

Thesis Supervisor: Clark Graham

Title: Associate Professor of Ocean Engineering

ACKNOWLEDGEMENTS

The author wishes to express his thanks to Associate Professor Clark Graham for his advice, guidance, and encouragement toward the development of this thesis. Also, the author must express his most sincere appreciation to his wife, Connie, for her tireless efforts in typing this manuscript.

TABLE OF CONTENTS

	Page
ABSTRACT	2
ACKNOWLEDGEMENTS	3
TABLE OF CONTENTS	4
LIST OF FIGURES	6
LIST OF TABLES	7
CHAPTER 1 INTRODUCTION	9
1.1 Background	9
1.2 Statement of Problem	11
1.3 Scope	12
1.4 Presentation of Thesis	13
CHAPTER 2 GENERAL SYNTHESIS MODEL DESCRIPTION	15
2.1 Introduction	15
2.2 Methodology for Program Development	15
2.3 Program Flow	22
CHAPTER 3 DETAILED PROGRAM DESCRIPTION	30
3.1 Introduction	30
3.2 MAIN Program	30
3.3 Subroutine DATA2	35
3.4 Subroutine SPAYLD	37
3.5 Subroutine GEOM	37
3.6 Subroutine UWDIM	39
3.7 Subroutine HPCALC	42
3.8 Subroutine CRVAL	44
3.9 Subroutine EPLANT	45
3.10 Subroutine MACHLQ	46
3.11 Subroutine MBSIZE	47
3.12 Subroutine VOLUME	50
3.13 Subroutine SHEER	57
3.14 Subroutine WEIGHT	60
3.15 Subroutine VRTCG	62
3.16 Subroutine FNCGRP	64
3.17 Subroutine SEASPD	64
3.18 Subroutine OUTPUT	68
CHAPTER 4 RESULTS OF MODEL APPLICATION	70
4.1 Introduction	70
4.2 Model in Conceptual Phase	71
4.3 Model Used to Update Design Predictions	74
4.4 Model as a Comparative Tool	83
4.5 Assessment of Results	89

TABLE OF CONTENTS (continued)

	Page
CHAPTER 5 CONCLUSIONS AND RECOMMENDATIONS	96
REFERENCES	100
APPENDIX A USERS GUIDE	102
APPENDIX B SAMPLE OUTPUT	127
APPENDIX C CLASSIFICATION SYSTEMS	141
APPENDIX D DERIVED EQUATIONS LISTING	152
APPENDIX E PROGRAM LISTING	178
APPENDIX F NOMENCLATURE LIST	269

LIST OF FIGURES

Figure No.	Title	Page
1	Program Control Organization	24
2	Logical Program Flow	25
3	MAIN Program Flow Chart	31
4	SPAYLD Subroutine Flow Chart	38
5	GEOM Subroutine Flow Chart	38
6	UWDIM Subroutine Flow Chart	40
7	HPCALC Subroutine Flow Chart	43
8	EPLANT Subroutine Flow Chart	48
9	MACHLQ Subroutine Flow Chart	48
10	MBSIZE Subroutine Flow Chart	49
11	VOLUME Subroutine Flow Chart	51
12	Superstructure Size	53
13	SHEER Subroutine Flow Chart	59
14	WEIGHT Subroutine Flow Chart	61
15	VRTCG Subroutine Flow Chart	63
16	FNCGRP Subroutine Flow Chart	65
17	SEASPD Subroutine Flow Chart	67
18	OUTPUT Subroutine Flow Chart	69

LIST OF TABLES

Table No.	Title	Page
1	Areas of Desired Flexibility	17
2	Model Flexibility	18
3	Comparisons of Calculated and Actual Characteristics--Conceptual Phase	72
4a	Comparisons of Calculated and Actual Characteristics--Design Update	75
4b	Design Update--Weight Comparisons	78
4c	Design Update--Volume Comparisons	79
5	Comparison of Model Results to the Actual Ship, C.G. Cutter Model, and DDO7 Model For the FFG-7 Design	82
6	Comparison of Model and CODESHIP Results for Full Load Displacement	82
7	FF-1052 to Soviet Design Standards	84
8	Sovietized FF-1052	86
9	Sovietized FF-1052 Characteristics	87
10	Estimated Soviet Kara Class Characteristics	88
11	Characteristics of FFG-7 Designed to High Performance Ship Standards	90
12	Problem Specifications	113
13	Payload Specifications	115
14	Weight Specifications	116
15	VCG Specifications	116
16	Volume Specifications	117
17	Electric Load Specifications	117
18	Miscellaneous Specifications	118

LIST OF TABLES (continued)

Table No.	Title	Page
19	Special Payload Specifications	119
20	Example Coefficients for Miscellaneous Specifications	120
21	Payload Shopping List	121
22	Functional Classification System	143
23	Modified BSCI Weight Groups	147

CHAPTER 1

INTRODUCTION

1.1 Background

The Conceptual Phase of ship design can be said to be made up of Feasibility Studies and the Concept Design. The Feasibility Study is the first and grossest estimate for a ship. The Concept Design is development and optimization of a single or limited number of selected Feasibility Studies to enhance absolute accuracy. Since a large number of Feasibility Studies are generally required to select a Concept Design, short-cut estimating techniques are often used with emphasis placed on relative accuracy among studies.

Until the early 1960's, Feasibility Studies were performed by the design engineer by completing a time consuming series of standard calculations for each study. Because of the time required to complete the Feasibility Studies, Navy designs of the past relied heavily on designs that had been done previously. These design studies produced what were a set of feasible characteristics. However, because of the limitations on the number of studies which could be conducted, an optimum set of characteristics was probably not obtained.

It was during the 1960's that the U. S. Navy began to look to the digital computer as a means of providing the required calculations to synthesize the ships being studied. By computerizing the calculation process, the designer would be freed from the routine calculations which had taken up most of his time during the earlier stages of design.

With the use of the computerized models, larger numbers of Feasibility Studies could be conducted. Since the optimum solution

is almost always the most desired solution, the designer using a ship synthesis model could conduct many more tradeoffs than in the past and be in a more favorable position when selecting the set of characteristics closest to optimum.

The development of ship synthesis models enabled the engineer to conduct systems level tradeoff studies early in the design on aspects which were seldom considered in detail before. These aspects include hull form, speed, endurance, and payload options, among others.

Another important characteristic of the computer model is that it allows consistency among feasibility studies. The consistency built into the model standard calculations allows the study results to be compared without the possibility of bias favoring certain concepts. With the human element involved in performing the hand calculations, it is difficult to insure that the same assumptions will be made for each study and that no bias is applied.

Several synthesis models for naval ships have been available for a number of years. Two Navy models were referred to extensively in developing the program presented in this thesis. The two models are the U. S. Navy's destroyer model, DDO7 (15)*, and Center for Naval Analyses Conceptual Design of Ships Model (CODESHIP) (3).

The destroyer model, DDO7, was first developed in the 1960's and has been continually updated since then. This model was developed to model only destroyer type ships. The Coast Guard Cutter Model of Reference (8) was patterned primarily after the

*Numbers in parenthesis refer to the references at the end of this thesis.

DDO7 model. Because of this, Reference (8) was also used extensively in developing the program presented in this thesis.

The general framework of a method of analysis for the CODESHIP model was first conceived at the Center for Naval Analyses in the mid 1960's. CODESHIP was developed to model ships which range in type and size from patrol craft to aircraft carriers. Because of the wide range of ship types and sizes in the data base, the CODESHIP model is probably not as accurate in predicting actual values as a model designed for a specific ship type, e.g., DDO7 for surface combatants. The greatest assets of the CODESHIP model are its versatile input and output features.

Existing models appear to be limited in that they do not provide the designer with the capability to change the design standards or practices from those which were built into the program, except for only a few exceptions. These models produce feasible ship results which cannot readily be changed to reflect desired standards or practices. Desired changes can be incorporated by changing estimating relationships or, in some cases, by inputting lump sums of weight or volume which when analyzing the results may be difficult to interpret.

1.2 Statement of Problem

The major problem with the ship synthesis models which currently exist is that they do not have the versatility required to answer many of the more specific questions which arise when considering the ship characteristics produced for any design. The kinds of questions which the models cannot readily answer concern "how the ship might have turned out if certain functional items had been

designed to standards or practices different from those standard calculations built into the model."

In answer to the above problem, this thesis is intended to provide a more versatile Ship Synthesis Model for Naval Surface Combatants. This model should allow the designer to control the design standards and practices to which the ship is designed and to observe the resulting ship characteristics from a more functional level than existing models provide. The model should be based on a set of standard calculations derived from the data base ships, but should offer the designer the flexibility to change the results by inputting values which reflect a different design practice or standard. The resulting model should enable the user to provide a significantly greater number of design options and a correspondingly greater ability to investigate solutions.

1.3 Scope

The program developed in this thesis is an attempt to satisfy the need for a more versatile Ship Synthesis Model for Naval Surface Combatants. With the growth of systems engineering in ship design, a more versatile model would allow the designer to place additional emphasis on tradeoffs at all phases of the design.

The model developed in this thesis is intended to have applications not only during the conceptual phase of design, which has been the traditional use for synthesis models, but during later phases of the design as well. The program is intended to have a variety of applications to ship design, but primarily as a model for conducting feasibility studies, a design aid for updating predictions in later stages of design, and as a tool

for conducting Comparative Naval Architecture Studies.

With the model developed and ready for use, the next step was to run several ship designs to allow for analyzing the results and determining if the desired versatility could be achieved. The results are discussed in Chapter 4.

The model is limited to surface displacement ships configured as naval combatants. Therefore, the model should not be used for synthesizing merchant types which are constructed to commercial standards. The weight data for the sample ships used in the development of the model ranges from full load displacements of 1770 to 16,294 tons. The length between perpendiculars for ships in the data base ranges from 301 feet to 700 feet. Therefore, designs that required extrapolations to very low or high values within individual component categories should not be made without additional investigations as to the reasonableness of the particular extrapolation.

The ship synthesis method developed is designed to provide detailed technical characteristics of the ships modeled. However, no cost characteristics are calculated by the model and are considered beyond the scope of this thesis.

1.4 Presentation of Thesis

Chapter 2 gives a general program description for development of the model. Sections are provided to discuss the methodology for program development and to explain the top level program flow.

Chapter 3 gives a detailed description of each of the subroutines used in the model.

Chapter 4 gives an evaluation of the model including results

of test runs made.

Chapter 5 contains conclusions and recommendations.

Appendix A services as a users guide to the program by providing a description of the input and a shopping list for payload items.

Appendix B gives a sample output listing.

Appendix C gives the classification systems used for volume and weight assignment.

Appendix D is a listing of all the equations derived from sample ship data to provide the calculations required in the model.

Appendix E is a listing of the program.

Appendix F is the nomenclature list for the entire thesis.

It is recommended that at least Chapters 1, 2, 4, 5 and Appendix A be read before attempting to use the program. The important aspects of each subroutine are covered in Chapter 3 which may be omitted without loss of continuity by anyone not interested in the details of the program.

CHAPTER 2

GENERAL SYNTHESIS MODEL DESCRIPTION

2.1 Introduction

This chapter gives the overall description of the solution method used to develop the synthesis model, as well as, the method used within the computer program to complete the ship calculations. The detailed description of the program is contained in Chapter 3.

Section 2.2 gives the methodology which was employed to arrive at the final model. Included in this section is a discussion of how the principal features of the program were selected and how they were incorporated in the model.

Section 2.3 discusses the overall program flow. This section explains the program execution required to complete a feasible ship design and indicates the iteration cycles required to obtain the degree of accuracy desired.

2.2 Methodology for Program Development

The design estimates produced by a synthesis model should be tailored to meet the conditions required of a feasible solution. First, there must be a balance between weight and displacement (Archimedes Principle). Second, internal space available must be equal to or greater than internal space required. In recent years this area/volume requirement has become the dominant factor in setting the size of U. S. Naval ships. The area/volume requirement complicates the synthesis model significantly, since detailed geometry calculations are required to provide the checks required. Third, the energy available must at least meet the energy required,

i.e., propulsion, auxiliary, and electrical power requirements must be met. Finally, the distribution of weight and volume must be such as to satisfy design criteria for transverse stability, girder strength, and seakeeping. These conditions for a feasible solution require iterative processes within the model to obtain a satisfactory solution.

The first step in developing a more versatile synthesis model was to develop a list of items or features for which input flexibility would be desirable. Table 1 lists several functional areas of the ship system where flexibility in model input would be desirable. This list of functional groups closely follows that of the U. S. Navy Space Classification System of Reference (17). By covering all of the functional groups, the list suggests that it would be desirable to be able to input or at least influence the design emphasis and establish design standards for a specific functional area when synthesizing a ship to a set of requirements.

Model flexibility for several ship models is indicated in Table 2. In this table the areas of desired flexibility have been more specifically defined. Model flexibility has been indicated by an "X" for the U. S. Navy DDO7 Destroyer Model (15), the Coast Guard Cutter Model (8), the CODESHIP Model (3), and the author's model. An "X" marked for an area of flexibility does not imply that the model has complete flexibility in that area or can handle all situations desired. It does mean that the model has some flexibility to control how the feature is considered.

The selection of features to be included in the model was based on availability of data and the capability to incorporate

TABLE 1

AREAS OF DESIRED FLEXIBILITY

*MILITARY MISSION

Communication & Detection

Weapons

Aviation

Special Missions

Cargo

PAYLOAD ITEMS

*PERSONNEL

Living

Support

Stowage

HABITABILITY

*SHIP OPS

Control

Main Propulsion Machinery

Auxiliary Systems

Maintenance

Stowage

Tankage

Passageways and Access

MOBILITY AND SHIP
SUPPORT ITEMS

*HULL

STABILITY, STRUCTURES,
ARRANGEMENTS, AND FORM

*SYSTEMS ENGINEERING

GENERAL ITEMS

TABLE 2

MODEL FLEXIBILITY

<u>FLEXIBILITY INCORPORATED</u>				<u>AREAS OF DESIRED FLEXIBILITY</u>
<u>DDO7*</u>	<u>CUTTER*</u>	<u>CODESHIP*</u>	<u>MODEL</u>	<u>MILITARY MISSION</u>
X	X	X	X	Electronics
X	X	X	X	Armament
X	X	X	X	Ammunition
X	X	X	X	Aircraft
X	X	X	X	Other Selected Items
				<u>PERSONNEL</u>
X	X	X	X	Accommodations
X	X	X	X	Separate OFF, CPO, ENL
X	X	X	X	Endurance Days Provision
			X	Messing, Rec., & other Support Services
			X	Potable Water & Personnel Stowage
				<u>SHIP OPS</u>
X	X	X	X	Power Plant Type
X			X	Electrical Plant Type
		X		Engine Location
		X	X	Shaft Type
X	X	X	X	Number Shafts
X	X	X	X	Sus. & End. Speed, Range --- H.P.

*DDO7 is the U.S. Navy Destroyer Model described in Reference (15). CUTTER is the Coast Guard Cutter Model in Reference (8). CODESHIP is the Center for Naval Analyses Model in Reference (3).

TABLE 2 (continued)

<u>FLEXIBILITY INCORPORATED</u>				<u>AREAS OF DESIRED FLEXIBILITY</u>
<u>DDO7</u>	<u>CUTTER</u>	<u>CODESHIP</u>	<u>MODEL</u>	<u>SHIP OPS</u>
X	X	X	X	Max. H.P. & Mach. Box Size --- Speed
			X	Maintenance & Stowage
			X	Passageway & Access Space Provided
X			X	Auxiliary Systems
			X	Office Space
X		X	X	Other Selected Items
				<u>HULL</u>
X	X	X	X	Hull Shape (Coef. & Dim.)
X	X	X	X	Hull Coating
		X		Hull Subdivision Std.
X	X	X	X	Hull & Superstructure Material
		X		Superstructure/Hull Ratio
			X	Structures
X	X	X	X	Stability(GM/B, F.S.)
X	X		X	Space Available
				<u>SYSTEMS ENGINEERING</u>
X	X		X	Ship Protection Level
X		X	X	Tolerance for Iterations
X	X	X	X	Design Margins
			X	Ship Silencing

the feature into the program within the required time frame. The ships used as the data base for developing model relationships were:

FF 1006	DL 1
FF 1033	DL 2
FF 1037	CG 9
FF 1040	CG 16
FF 1052	CG 26
FFG 7	CGN 25
DD 445	CGN 35
DD 692	CGN 36
DD 931	CGN 38
DD 963	CGN 9
DDG 2	

The versatility of the model is best understood by referring to the Users Guide of Appendix A. The versatility is generally accomplished by use of the following techniques:

- a. input elements for problem specifications;
- b. options on selecting several ship features;
- c. payload shopping list for selection of payload items;
- d. calculations of BSCI* weight groups, vertical centers of gravity for all weight groups, volume groups, and electric load groups which are not defined as input items (groups defined in Appendix C);

*BSCI--"Bureau of Ships Consolidated Index of Drawings, Materials, and Services Related to Construction and Conversion" of February 1965 as given in an appendix to Reference (20).

- e. option to override the calculation of any weight group, vcg, volume group, or electric load group by direct input;
- f. elements for inputing miscellaneous specifications (mainly habitability coefficients);
- g. elements for inputing miscellaneous payload not on the shopping list; and,
- h. results displayed in a detailed output listing.

A new functional classification system was developed to aid in the analysis of results and to assist as a comparative tool when assessing the impact of a function on ship design. The functional classification system is listed in Appendix C, and is derived from selecting the appropriate volume and weight groups for each function. This classification system enables a density to be calculated for each function.

After deciding what features to use, how to incorporate the versatility, and developing a classification system, the required relationships to complete the model were derived using data gathered from the ships previously mentioned. The relationships derived are given in Appendix D and include the following:

- a. starting estimates for full load displacement and center of gravity;
- b. some geometry relationships;
- c. linear fit to powering curves;
- d. weight equations;
- e. vertical center of gravity equations;
- f. volume equations;
- g. electric load equations; and,

h. equipment sizing relationships.

With the above completed, the computer model was ready to be constructed. The model was formed by taking what were judged to be the best features of the existing models and incorporating the flexibility desired into the program. The general features of the model formulation can be summarized as below:

- a. input and output are patterned after the CODESHIP Model (3);
- b. geometry, horsepower, electric plant, machinery liquids, volume, weight, vcg, sheer, sea speed routines and internal flow of program are much like DDO7 and the Coast Guard Model;
- c. model uses all of the derived relationships found in Appendix D and incorporates the logic for the versatility items;
- d. results are converted to the new functional classification system and BSCI groups for output; and,
- e. a summary of results is selected to include the overall ship characteristics.

The model developed does not attempt to define or check the arrangements required for the ship. Because of this, highly arrangement dependent calculations cannot be performed. These would include damaged stability, topside arrangement, longitudinal balance, and strength calculations. However, for many ship types there is sufficient flexibility in the arrangement of the design to allow a satisfactory solution in these areas to be attained.

2.3 Program Flow

The program is controlled by the main program. The main

program calls the subroutines as required to calculate information for output and to let program execution proceed. Program control organization is shown in Figure 1.

The logical program organization or top level schematic of program flow is shown in Figure 2. This figure indicates how the program solves each problem.

The program begins by reading in the following data:

- a. names of items to be printed in the output;
- b. residual resistance coefficient values taken from the Taylor Standard Series (7); and,
- c. data for all the items in the payload shopping list.

This data is read in only once and is used for calculations on all of the ships being run.

The next step is to read in the specifications for the next ship to be run. It is this point in the program where control returns upon completing the output of a ship. The ship data is read in using subroutine DATA2 which allows unformatted data to be read into arrays for storage.

The program next calls subroutine SPAYLD which is used to sort the weights of the payload items input and place them in the proper BSCI weight group. The value of WPAYIN, the total weight of payload input, is calculated to be used for the initial estimating of full load displacement should the value of LBP not be specified.

At this point the underwater shape of the hull is calculated. If the LBP is given as input, control passes to subroutine UWDIM. Values input to this subroutine are LBP, free surface correction, C_p , C_x , GM/B, as well as estimated KG and full load displacement.

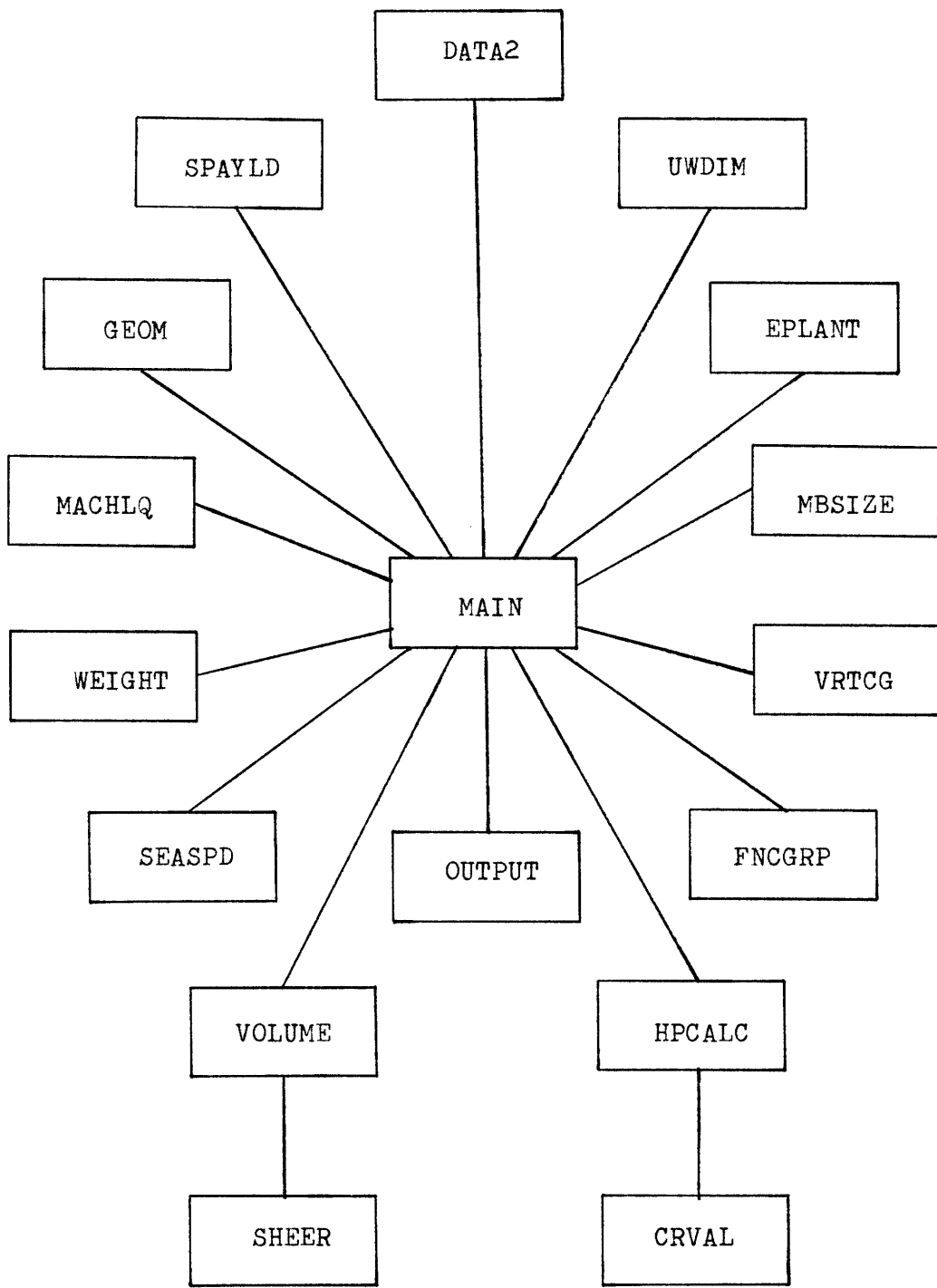

PROGRAM CONTROL ORGANIZATION

Figure 1

LOGICAL PROGRAM FLOW

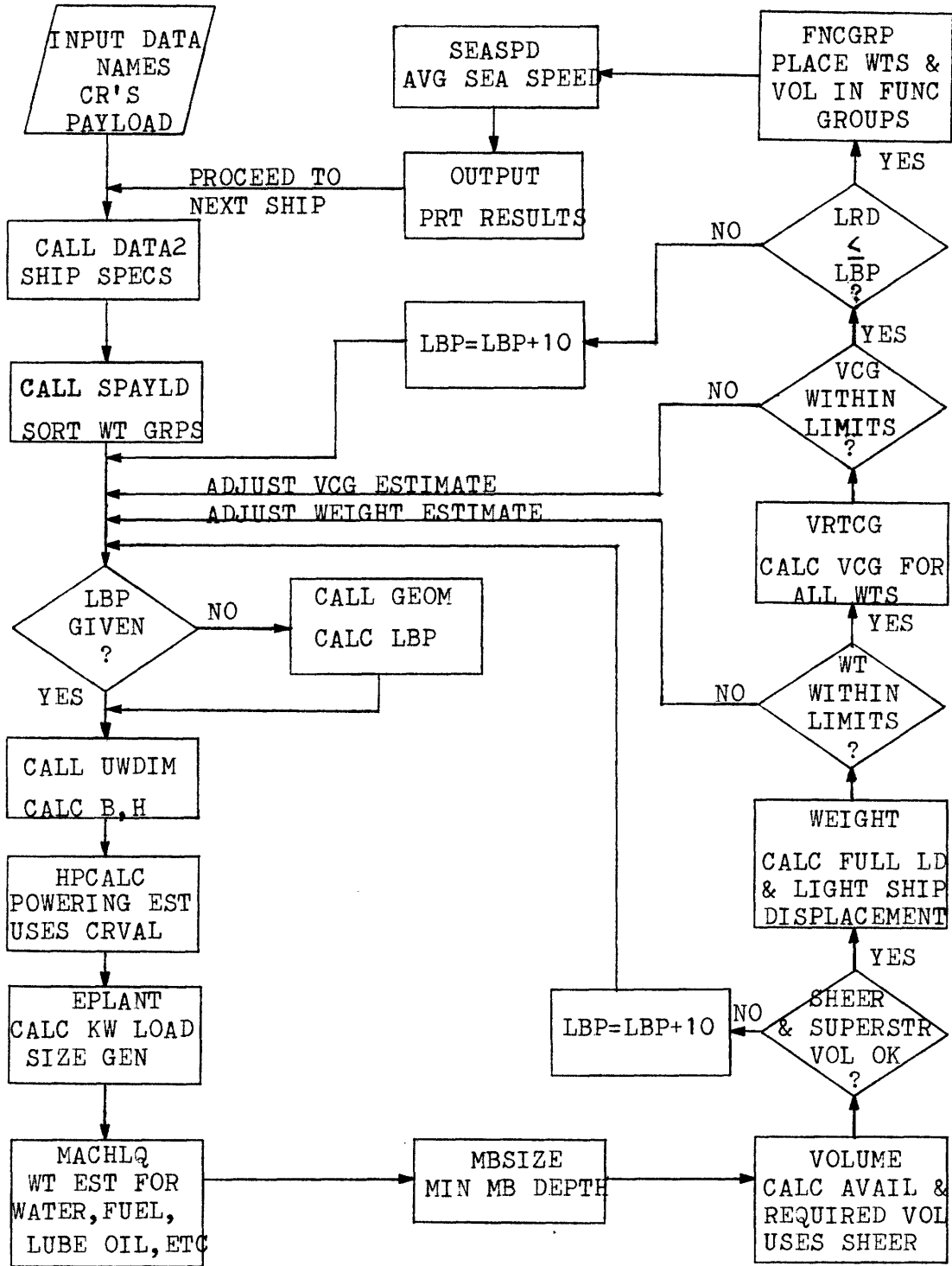

Figure 2

Output values from this subroutine are B, H, and C_{wp} .

If LBP is not an input, but values for L/B and B/H are input, the control first goes to subroutine GEOM where LBP is calculated. UWDIM is then called to complete the calculations for B, H, and C_{wp} . Inputs to GEOM are L/B, B/H, C_p , C_x , and estimated full load displacement.

Subroutine HPCALC is now called to determine either the maximum sustained speed, VSUS, or the horsepower required at maximum sustained speed, SHP. If VSUS is input, then HPCALC along with subroutine CRVAL, estimates the horsepower required to maintain the maximum sustained speed. If SHP is input, then HPCALC is used to compute VSUS. HPCALC is written to take speed as an input and return a value of horsepower; therefore, to find VSUS an iterative procedure is used.

Subroutine HPCALC is called on again to determine the horsepower required at endurance speed. A value for endurance speed must be input.

HPCALC uses a Taylor Standard Series horsepower estimate. Values for the residual resistance coefficient, C_r , are stored in arrays and subroutine CRVAL is used to choose the correct C_r value.

The program is now ready to make the electric plant related calculations. Subroutine EPLANT is used to determine the cruise, battle, and 24 hour average electric loads, and also, to determine the number and size of generators required, if they are not specified.

Subroutine MACHLQ is called next in the program to calculate the weight of potable water, reserve feed water, ship lube oil, fuel oil and diesel oil. These weights are calculated at this

point since they are used to determine the associated tankage volume which is calculated before the rest of the ship weights are found.

The minimum depth for the machinery box must be determined since this is also the minimum depth which the ship can have. Subroutine MBSIZE is called next to make this calculation.

The program is now ready to calculate both the required and available volumes for the ship and to make adjustments to the ship geometry to balance these requirements. Since most U. S. Navy surface ships are considered to be volume limited, this volume balance is perhaps the most important iteration in the design. Subroutine VOLUME supplies all of the volume calculations and adjustments which include the following:

- a. calculation of the volume required for all of the functional groups of Appendix C;
- b. use of subroutine SHEER to determine an acceptable sheer line and resulting depth at stations 0, 10, and 20;
- c. adjustment of superstructure size to achieve volume balance, if possible;
- d. addition of a raised deck if additional volume is required;
- e. consideration of tankage space available and flare of ship in determining usable arrangement volume; and,
- f. increment to length if the maximum superstructure volume available is insufficient or if an acceptable sheer line cannot be found.

The weights of all light ship and load items which are not payload input are next determined in subroutine WEIGHT. At the

completion of WEIGHT, the new full load displacement is compared to the previous estimate. If the two values are within the displacement tolerance required, a balance has been reached and the program proceeds to estimate the vertical center of gravity. If the two values are not close enough, a new estimate is made and control is returned to either GEOM or UWDIM to reestimate the dimensions.

Subroutine VRTCG is now called to estimate the vertical center of gravity of all weight groups including the payload associated groups. The estimated VCG for the ship is compared to the previous estimate. If the difference is less than the allowed difference, control proceeds on, but if they are not close enough control goes back to GEOM or UWDIM.

A check is made at this point to see if a long raised deck (LRD) was added which is longer than the LBP. If the value of LRD is greater than LBP, a message is printed and the length of the ship is increased by 10 feet and control returned to UWDIM. If LRD is less than or equal to LBP, a balanced and feasible ship has been calculated.

Subroutine FNCGRP is called next to place the weights and volumes calculated into the proper functional groups as described in Appendix C.

An estimate of the speed the vessel will be able to sustain in the North Atlantic Ocean is made in subroutine SEASPD. The output of SEASPD offers a means of making a relative comparison of seakeeping characteristics between ships.

Finally, subroutine OUTPUT is called to print the results. The input specifications are printed first, followed by the payload

input, summary of results, functional group results, BSCI weight listing, and functional electric loads.

Details of each subroutine and the main program are contained in Chapter 3.

CHAPTER 3

DETAILED PROGRAM DESCRIPTION

3.1 Introduction

This chapter provides a discussion of the detailed flow of the program. The main program and each of the program subroutines are discussed to the level of detail necessary to explain how the required calculations are made. The step-by-step analysis of the model program is left to the reader. A program listing is provided in Appendix E.

Section 3.2 provides the discussion of the main program. All subroutines are discussed in sections 3.3 through 3.18 in the order in which they are called by the main program.

3.2 MAIN Program

The MAIN program controls the execution of each trial case. All but two of the remaining subroutines are called from the MAIN program. A flow chart from this routine is given in Figure 3.

The real, integer, data, dimension, and labeled common statements used are first defined. Labeled common statements are used throughout the program to transfer data and save computer storage area.

The program next reads in values from data for the following:

- a. specification names;
- b. type names;
- c. summary of result names;
- d. functional component names;
- e. BSCI weight group names;

MAIN PROGRAM FLOW CHART

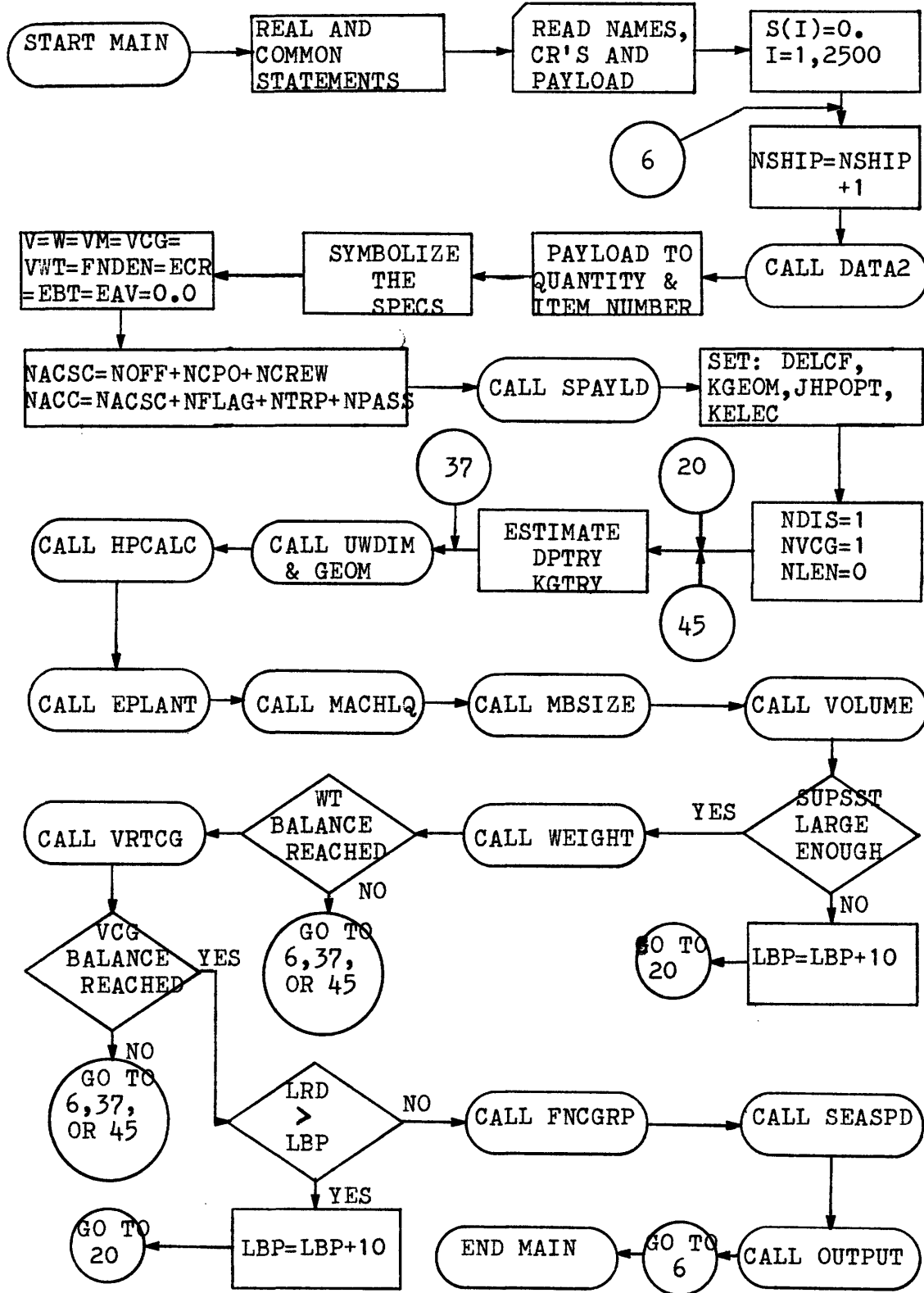

Figure 3

- f. electric functional group names;
- g. C_r array; and,
- h. payload shopping list.

The data for items a through g above is given in the listing of Appendix E.

The input specification array is now initialized to zero. The ship number index is incremented to show the current ship being calculated.

The specification items for the next ship are read in next. The program now transforms the payload specifications input to a quantity of each item and an associated item number which is used to refer to the payload for later calculations.

The input specifications are now symbolized to allow for easier identification within the program, e.g., VSUS = S(1) and VEND = S(2). The arrays used to store results for volumes, weights, vertical centers, densities, and electric loads are initialized to zero before the calculations begin.

The calculation is now made to compute the number of ships company and total accommodations required. Subroutine SPAYLD is now called to calculate the weights of the payload items input and the total weight of the payload, WPAYIN, which may be required for an initial displacement estimate.

The frictional resistance correction factor, DELCF, is now set equal to .0004 if no value is specified in the input array. Program pointers for calculating ship geometry, horsepower, and electric plant are next set as follows:

- a. KGEOM = 0 if LBP = 0, KGEOM = 1 if LBP > 0;

- b. $JHPOPT = 1$ if $SHP = 0$, $JHP = 2$ if $SHP > 0$; and,
- c. $KELEC = 0$ if electric plant size is not given, $KELEC = 1$ if electric plant size is given.

The program next initializes the counters used for iteration of weight, v_{cg} , and length. An initial estimate of full load displacement is made at this point. These equations as well as all others used in the program are found in Appendix D. If LBP is given the program goes to subroutine UWDIM to calculate the dimensions. If however, L/B and B/H are given instead of LBP, subroutine GEOM is used to obtain LBP, and then UWDIM is called. Values received from UWDIM are B, H, and C_{wp} . An initial value for KG is also estimated in the MAIN program at this point.

The propulsive coefficients at endurance and maximum speeds are now set, if not specified. Subroutine HPCALC is used to obtain values for VSUS, SHP, and horsepower at endurance speed. If SHP is given, then VSUS is calculated or the reverse if VSUS is provided. When the maximum sustained horsepower is specified, a modified Newton-Raphson technique is used as in Reference (8), with the slope approximated by a secant to the speed-power curve, to calculate VSUS.

Subroutine EPLANT is called next to calculate the electric loads and size generators, if not given. MACHLQ is called to obtain the weight of liquid load items. The next subroutine used is MBSIZE to estimate the minimum machinery box depth.

Subroutine VOLUME is used to calculate the volumes required for all functional groups and to size the superstructure and ship depth to meet the requirements. If the largest superstructure

size acceptable is not big enough, the LBP is increased by 10 feet and calculation of the ship starts over.

The BSCI weight groups are now estimated in subroutine WEIGHT. A modified Newton-Raphson technique is used to iterate full load displacement until convergence between estimated and calculated values is obtained. The method used is described in detail in Volume II of Reference (3). If a weight balance cannot be reached within the specified number of iterations, a "no balance" message will be printed and the next ship will be called.

The vertical center of gravity for all weight groups is calculated in subroutine VRTCG. A check is made for convergence of the vertical center of gravity estimate for the ship. The average of the estimated and calculated values is used to iterate the KG try. If the vcg counter exceeds the allowed number of iterations, a "no balance" message is printed and the next ship tried.

A check is next made to see if a long raised deck was added and if that length was longer than LBP. If LRD is greater than LBP, then LBP is increased by 10 feet and the ship is recalculated.

Once the ship size is set, the next step is to calculate the functional weights and volumes according to Appendix C. This is done by subroutine FNCGRP. The density of each function is also calculated in pounds per cubic foot.

Subroutine SEASPD is now called to estimate an average sustained speed in the North Atlantic Ocean. Subroutine OUTPUT is called last to print the ship results. Control now returns to the beginning to input the next ship.

The listing of the MAIN program concludes with a listing of

print and format statements which are used if any default option is encountered. The default is printed and control returns for the next ship input.

3.3 Subroutine DATA2

Subroutine DATA2 was adapted from Reference (13) for use in reading the data for each ship. The detailed description of the subroutine as well as the detailed flow charts may be found in the reference and are not reproduced here. The subroutine was found to be very useful for a program like the ship synthesis model, since it allows format free data to be input into arrays or matrices for easy storage and manipulation.

Each card to be read using DATA2 must begin with an address field followed by one or more value fields. A field is defined as a group of characters terminated by a blank. A field having the last non-blank character in column 72 of the data card is acceptable. The address refers to the location in a given array in which a data item is to be stored.

The value fields are the data items being input and are of the form

$$\pm A \dots AA.aa\dots a \pm B\dots BB.bb\dots$$

which is interpreted as

$$\pm A\dots AA.aa\dots a \times 10^{\pm B\dots BB.bb}$$

The portion represented by the A's is called the coefficient; the portion represented by B's is called the exponent. An unsigned coefficient is assumed to be positive. For example the card:

14 1+1 21.2 -7-3

would yield 10 as the 14th element in a given array, 21.2 as the

15th element and -.007 as the 16th element.

The address may be multi-dimensional, e.g., the card:

1,1,4 17.2

would place 17.2 in element (1,1,4) of the given array. There is no limit to the number of dimensions used.

No alphabetic characters will be accepted by the routine. Also care must be taken when several value fields are given on a card with a multi-dimensional address. For example, when reading in the payload, element (1,4) is followed by element (2,4) since there are 7 rows in the payload matrix, P(7,300).

If data items were to be entered into a singly dimensioned array, e.g., S, the calling sequence to DATA2 would be

CALL DATA2 (S, IND, 2500)

where 2500 is the size of the array and IND is a fixed point indicator having the following possible values upon returning to the MAIN program.

- (1) IND = 0 - Routine encountered a blank card read. No following cards were read. By using a blank card as the last card of a data set, this becomes the normal return value.
- (2) IND = 1 - Routine found the first card read was a blank card. No following cards were read. By using a blank card as the last card of an input deck, this return indicates the end of the input deck has been reached.
- (3) IND = 2 - An unacceptable data card was read. No following cards were read and an error

message was written of the form, "BAD DATA
CARD . . . (card image)".

For a multiple dimension array, such as P(7,300), the sub-
routine DATA2 would be entered by

```
CALL DATA2(P, INDP, 2100)
```

where INDP is a 3-item array. The array in this case happens
to be INDP(1) = 2 (the number of dimensions of P), INDP(2) = 7
(size of the first dimension), and INDP (3) = 300(size of the second
dimension). Upon returning from DATA2, INDP(1) serves as the
indicator and would have the above-mentioned possible values of IND.

3.4 Subroutine SPAYLD

Subroutine SPAYLD is used to sort the weights of the payload
items into the proper BSCI weight groups. The subroutine checks
each item of payload to see which weight group it should be placed
in. SPAYLD then multiplies the quantity of the item times the
weight per item and places the result in the weight array element
corresponding to the weight group. The flow chart for this sub-
routine is given in Figure 4.

The final result provided in the subroutine is the total
weight of all payload items input. This total payload weight,
WPAYIN, may be required by the MAIN program to estimate full
load displacement.

3.5 Subroutine GEOM

Subroutine GEOM is used to provide a value for the length
of the ship if LBP is not input. If LBP is input to the program,
GEOM is not used. The flow chart for GEOM is given in Figure 5.

SPAYLD SUBROUTINE FLOW CHART

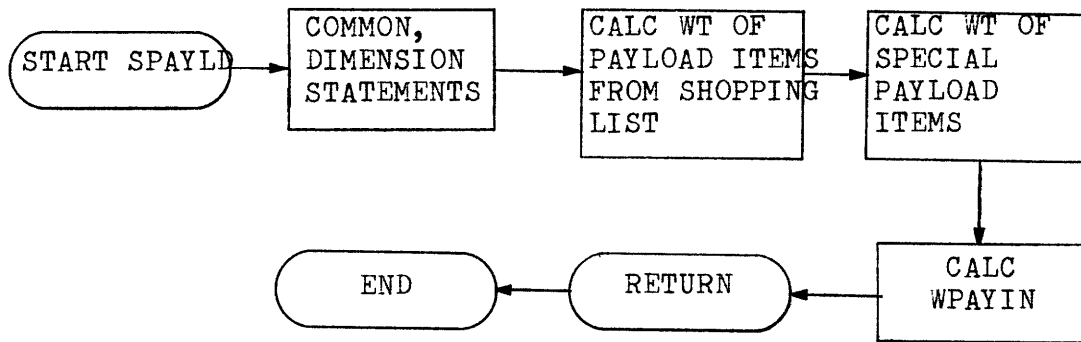

Figure 4

GEOM SUBROUTINE FLOW CHART

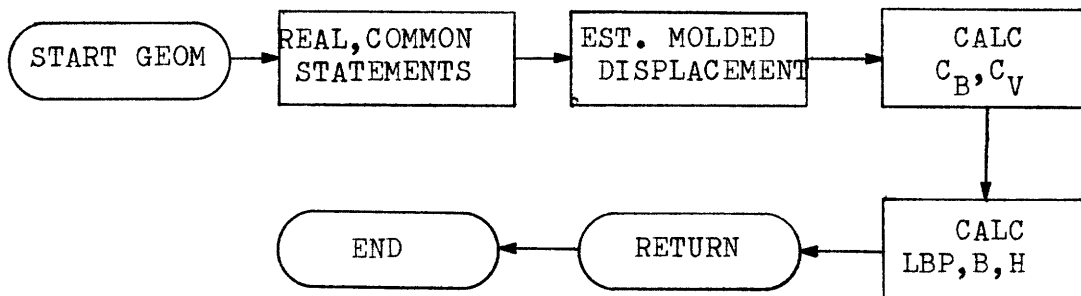

Figure 5

When it is required to use GEOM, values for the estimated full load displacement, C_p , C_x , L/B and B/H are used with the standard geometry equations of naval architecture to provide the unconstrained dimensions of the ship. Besides a value for LBP, B and H are also calculated, but may be changed later in the program to satisfy stability requirements.

Throughout the program, it is assumed that the total displacement is 1.4 percent greater than the molded displacement. The molded displacement is used for the calculations of GEOM.

3.6 Subroutine UWDIM

The values for beam and draft are calculated in subroutine UWDIM. Inputs to this subroutine are length, C_p , C_x , displacement try, KG try, and GM/B. The waterplane coefficient, C_{wp} , is also calculated, but only as a linear function of C_B . A flow chart for this subroutine is shown in Figure 6.

Since displacement is an input to this routine, the value of beam times draft is fixed as:

$$B \times T = \text{Displacement} \times 35. / (\text{LBP} \times C_p \times C_x)$$

Reference (2) may be referred to for a detailed definition of naval architecture variables used in this routine.

The beam to draft ratio, B/H, is determined by the GM/B criterion where GM available is given by the formula:

$$GM = KB + BM - KG - \text{Free surface correction}$$

A value for KB is estimated using Morrish's approximate formula:

$$KB = H - 1/3 \times (H/2 + \nabla/A)$$

where: H is the draft in feet

UWDIM SUBROUTINE FLOW CHART

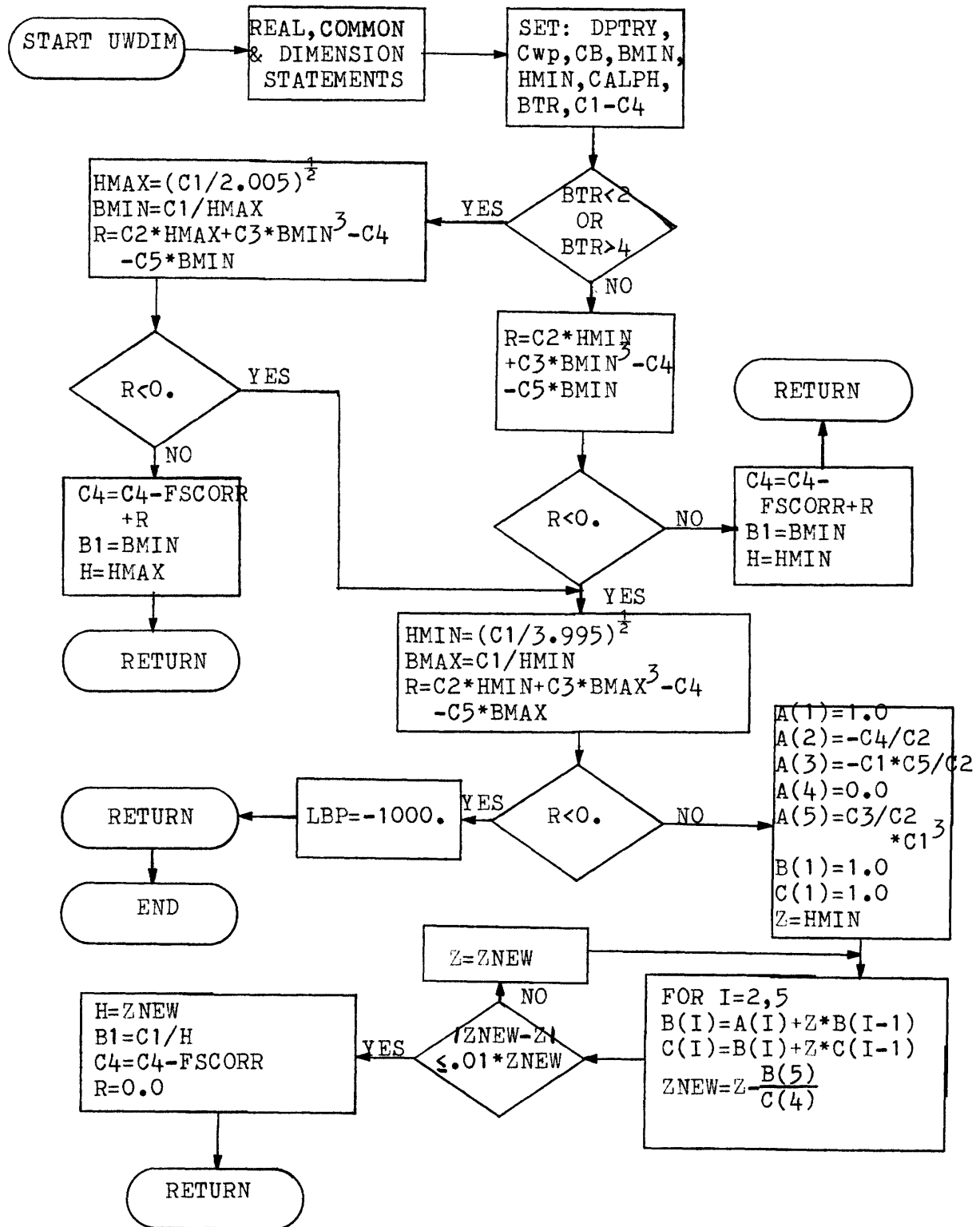

Figure 6

∇ is the volume of displacement = $B \times H \times LBP \times C_p \times C_x$, ft^3 .

A is the waterplane area = $B \times LBP \times C_{wp}$, sq. ft.

A value for BM is estimated using:

$$BM = \frac{LBP \times B^3 \times C_{\alpha}}{\nabla}$$

where C_{α} is a transverse moment of inertia coefficient which is assumed to be a linear function of C_p .

A number of coefficients are used in this routine which are defined by the above equations. These coefficients are:

$$C1 = DPTRY * 35. / (LBP * C_p * C_x) = B \times H$$

$$C2 = .833 - C_p * C_x / (3. * C_{wp}) = KB/H$$

$$C3 = LBP * CALPH / (DPTRY * 35.) = BM/B^3$$

$$C4 = KG + FSCORR$$

$$C5 = GM/B = GMBMIN$$

A variable R is introduced in the subroutine with a value of:

$$R = KB + BM - GM - KG - FSCORR$$

When $R = 0$, the stability criterion that $GM = C5 \times B$ is just satisfied. This condition gives the desired solution. However, the solution is only valid provided the value for beam to draft ratio remains within the limits specified by the speed-power estimation which are:

$$2.0 \leq B/H \leq 4.0$$

or since $B = C1/H$

$$(C1/4)^{\frac{1}{2}} \leq H \leq (C1/2)^{\frac{1}{2}}$$

The solution method used to obtain the final dimensions of the ship is an iterative one and is described in full detail in Reference (8).

3.7 Subroutine HPCALC

Subroutine HPCALC performs the speed-power estimates required by the program. The subroutine uses the Taylor Standard Series power estimation of Reference (7). The procedure used is very nearly that of the hand calculating procedure. The flow chart for the subroutine is given in Figure 7.

Two problems of interest arise with regard to doing the calculations on a computer. The first problem is choosing the correct value for the residual resistance coefficient, C_r , from the curves of Reference (7). The method for obtaining C_r in the program was taken from Reference (8) where the C_r curves are converted to array form and stored in the program. Subroutine CRVAL, described in the next section, chooses the correct value of C_r from this stored array.

The second problem is that of computing the surface area of the hull. This is accomplished by using the equation developed in Reference (8) which is:

$$S = (1.7 \cdot L \cdot T + \nabla/T)(.0053(B/T)^2 - .02(B/T) + 3 \cdot C_v + .08 \cdot C_p + .926)$$

Although this formula may not be the most accurate method, it is considered to give values within 5 percent of the values calculated from the curves of Reference (7) over the entire range. The results are considered to be very satisfactory for the program and further refinement in this area was not considered necessary.

Also, linear approximations to the curves of Reference (9), used for calculating effective horsepower with appendages and effective horsepower total, once effective horsepower bare hull is

HPCALC SUBROUTINE FLOW CHART

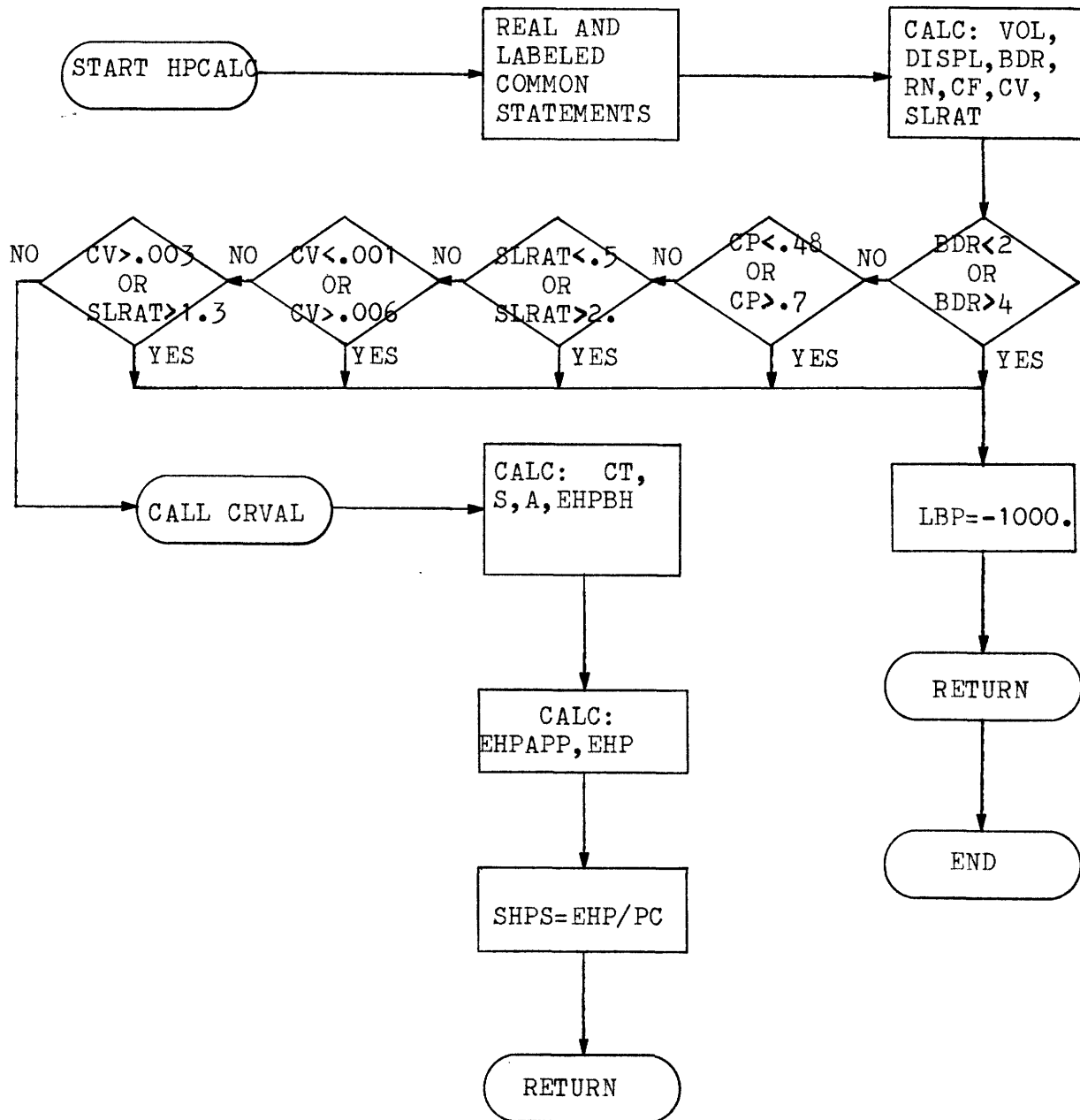

Figure 7

known, are included in the subroutine. These equations are listed in Appendix D.

3.8 Subroutine CRVAL

The only function of subroutine CRVAL is to choose from stored data arrays the values of the residuary resistance coefficient, C_r , which straddle the input point and then to interpolate to find the value of C_r at the input point. The input point is specified by the four variables: beam to draft ratio, C_p , C_v , and speed length ratio.

The CRVAL subroutine used in the program was taken directly from Reference (8). The constants stored in the three arrays which contain the C_r data were originally determined using the curves of Reference (7). Although the three arrays (CR1, CR2, and CR3) are each one dimensional, the data they contain is four dimensional, varying with each of the four variables which specify the input point.

The maximum ranges for the input variables that are accepted are listed below:

$$2.0 \leq B/H \leq 4.0$$

$$.48 \leq C_p \leq .70$$

$$.001 \leq C_v \leq .006 \text{ for } 0.5 \leq V/\sqrt{L} \leq 1.3$$

$$.001 \leq C_v \leq .003 \text{ for } 0.5 \leq V/\sqrt{L} \leq 2.0$$

Sixteen values of C_r are required to straddle the input values of B/H , C_p , C_v , and V/L . After these sixteen numbers have been chosen, the value of C_r at the input point is found by interpolation. A total of fifteen interpolations are required, eight to select the correct speed length ratio, four to select the

correct C_p , two to select the correct beam to draft ratio, and a final one to select the correct C_v .

A more detailed description of the subroutine and the subroutine flow chart are found in Reference (8).

3.9 Subroutine EPLANT

Subroutine EPLANT performs two basic functions. The first is to estimate the functional electric loads for cruise, battle, and 24 hour average conditions for use in sizing the electric plant, if required, and in calculating fuel requirements. The second function is to size the generators, if the size is not input. The flow chart for the subroutine is given in Figure 8.

The ships used in developing the electrical load relations were:

FFG-7	FF-1052
DD-963	CG-9
DDG-2	DDG-FY 67
FFG-1	

The equations which were derived for estimating the electrical loads and sizing the electric plant are given in Appendix D. Electric loads for cruise, battle, and 24 hour average are calculated for the following groups:

<u>Group</u>	<u>Function</u>
100	Propulsion Auxiliaries and Steering
200	Auxiliary Machinery
300	Deck Machinery
400	Shops
500	Interior Communications and Electronics

<u>Group</u>	<u>Function</u>
600	Ordnance System
700	Hotel
800	Air Conditioning and Ventilation
900	Power Conversion Equipment

An electric load growth margin is also applied to each group and a group total is calculated to include the margin. The growth margin is generally added to new designs and major conversions to provide sufficient generating capacity for the entire life of a ship. For combatant ships the margin is usually taken to be 30 percent.

The subroutine first calculates the cruise loads, followed by the battle loads, and then the 24 hour average loads. At this point a test is made to determine if the electric plant size has been specified. If the electric plant is input, the subroutine has only to total the number of generators input for ship service and emergency use and determine the ship service, emergency and total installed generating capacities.

If the electric plant size is not input, the subroutine then performs the calculations and checks required to size the plant. Once the size is determined, the type of ship service and emergency generators is checked and the final number of each type generator is found.

3.10 Subroutine MACHLQ

Since the shaft horsepower required for propulsion and size of the electric plant have been determined, the weight of fuel, lube oil, potable water, reserve feed water, and diesel oil can

be calculated. These calculations are performed in subroutine MACHLQ. The weight of the variable load liquids is calculated at this point because it is needed to determine the required tankage volume and the volume calculations precede those for other weights. A flow chart for the subroutine is given in Figure 9.

The equations used to calculate the liquid weights are listed in Appendix D. The equations derived for specific fuel consumption and fuel rate were based on data given in Reference (12) for all but the COGAS plant and from Reference (1) for that plant.

3.11 Subroutine MBSIZE

The only purpose of subroutine MBSIZE is to determine the minimum allowable depth of the machinery compartment. The equations derived for this subroutine were based upon data taken from Reference (14) and are listed in Appendix D. The flow chart for the subroutine is given in Figure 10.

It was determined that the only critical dimension of the machinery box was depth. This is due to the manner in which the volumes for machinery systems were broken down for estimating purposes. The machinery box as defined for the program contains the volume for all machinery systems except uptakes, shaft alleys, maneuvering related spaces (steering room), and ventilation spaces (fan rooms). The machinery box would therefore contain all of the following spaces:

boiler and firerooms	auxiliary machinery spaces
reactor spaces	electrical generator rooms
engine, motor and gear rooms	switchboard spaces
combined machinery spaces	pump rooms

EPLANT SUBROUTINE FLOW CHART

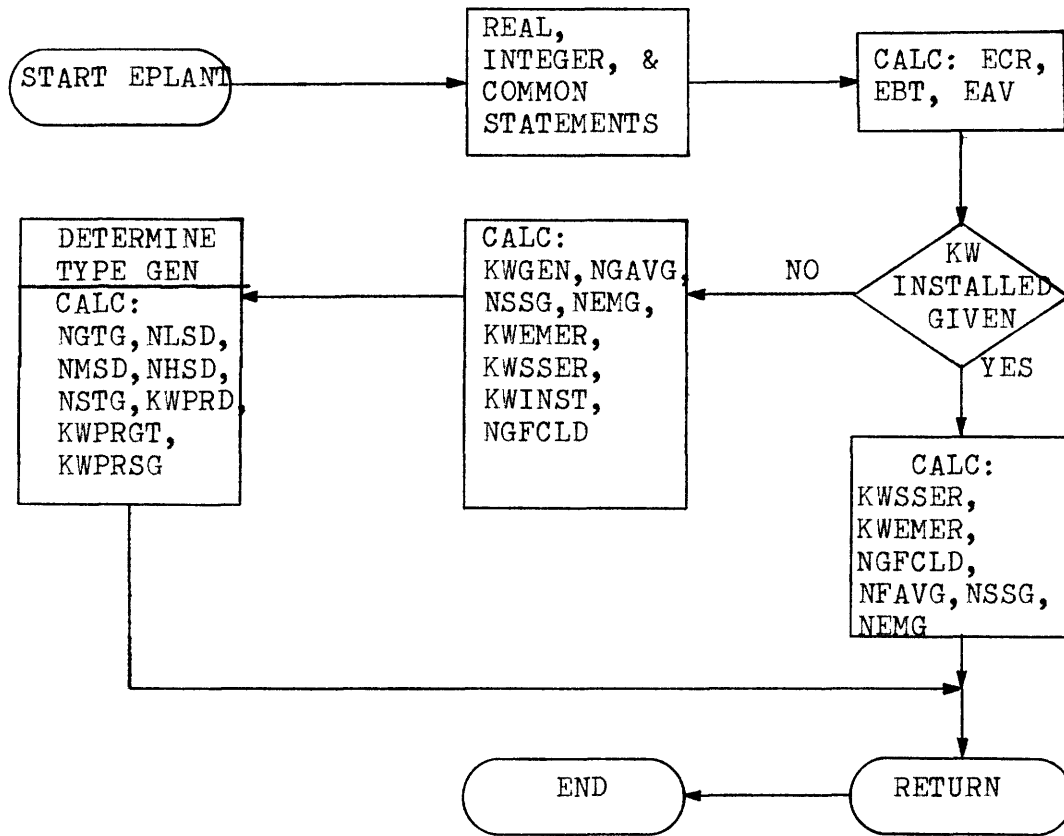

Figure 8

MACHLQ SUBROUTINE FLOW CHART

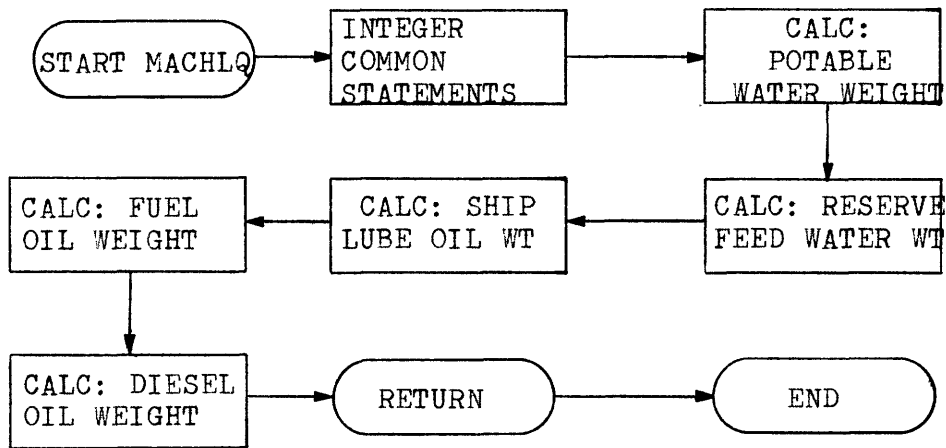

Figure 9

MBSIZE SUBROUTINE FLOW CHART

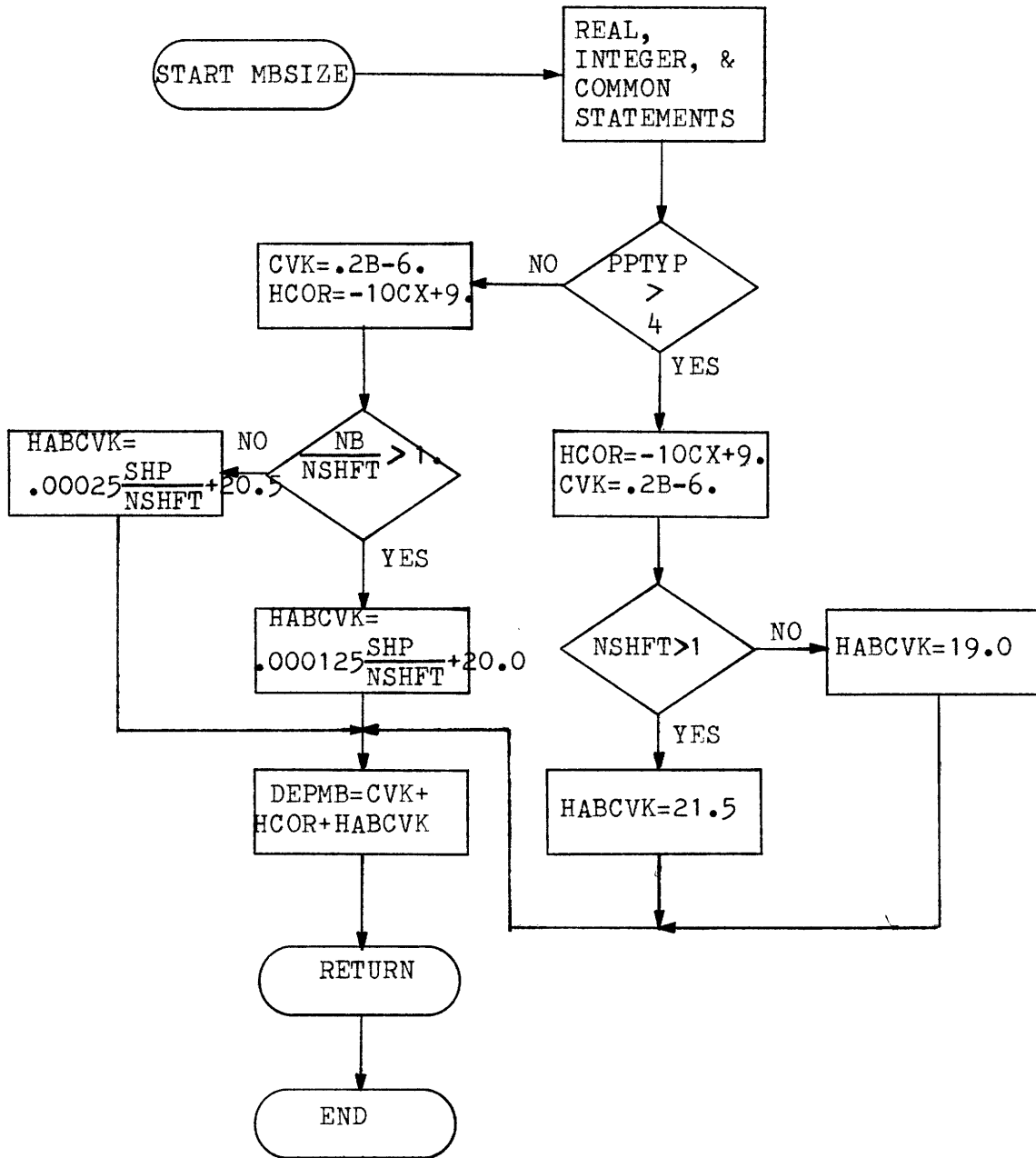

Figure 10

The volume routine estimates one volume to include the above functions. It would be up to the arrangements engineer to divide the volume allocated into the appropriate machinery spaces. Because of the large volume which would be associated with the machinery box, it was felt that the longest length requirement could always be met by appropriate arrangement of other functions within the machinery box. Similarly, it was felt that the beam selected for the ship by subroutine UWDIM would be adequate for the machinery box and no minimum beam is estimated.

Results using the machinery box concept described above were found to be very good. Since most warships contain primarily the same types of equipments, but not always located in the same spaces, a much better correlation for the total volume for these functions could be attained than for individual functions.

3.12 Subroutine VOLUME

Most of the U. S. Navy ships of recent design are considered volume rather than weight limited. Because of this it is important that the synthesis model determine a balance between required and available volume as well as between weight and displacement. Subroutine VOLUME performs this function in the model. A flow chart for this routine is shown in Figure 11.

Since dimensions of the hull below the load waterline are determined in subroutine UWDIM, only the sheer line, deckhouse volume, and the length of raised deck, if any, remain to be determined to define the volume available in the ship. The enclosed volume of the hull and deckhouse will be completely determined by these variables.

VOLUME SUBROUTINE FLOW CHART

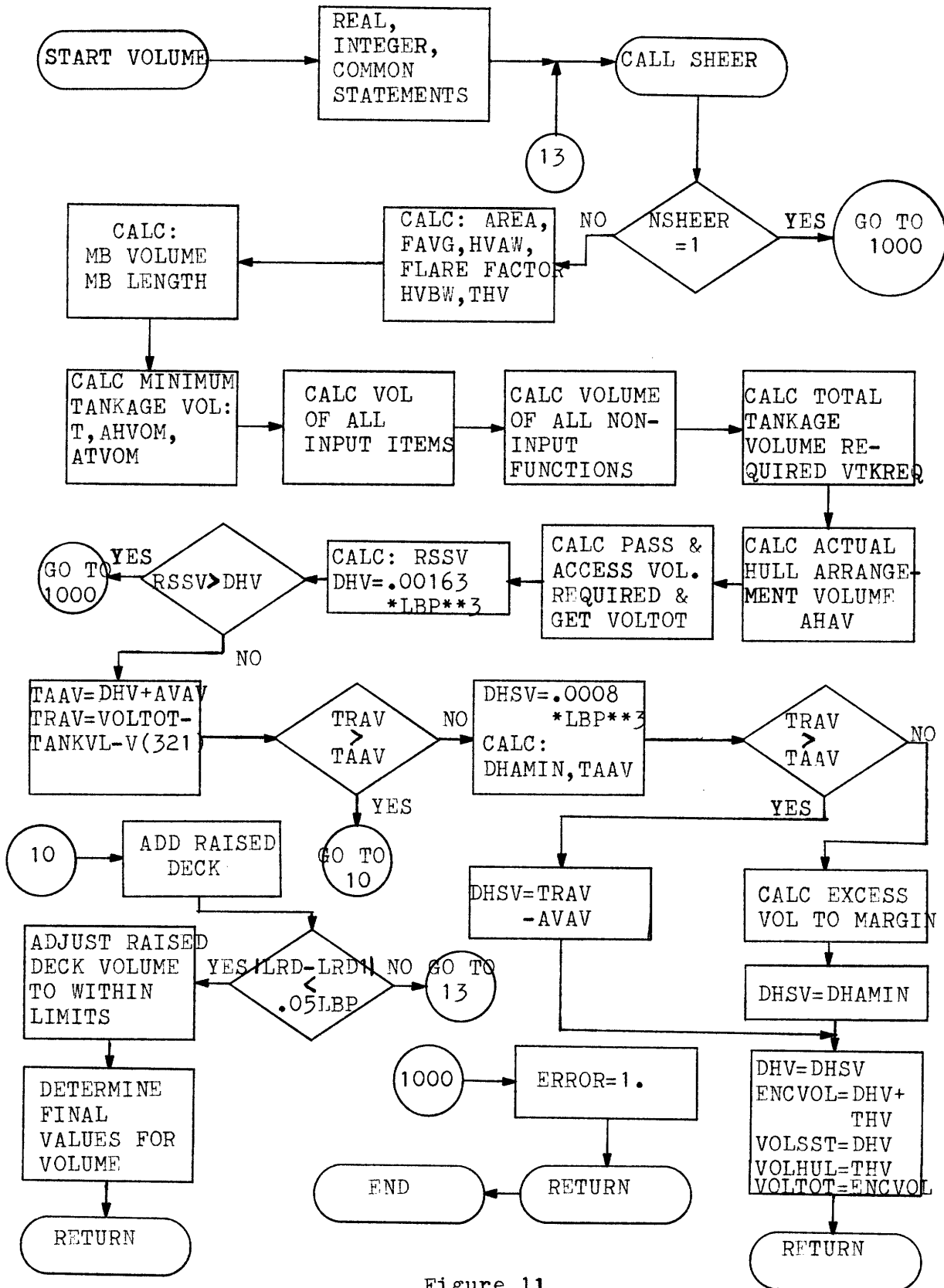

Figure 11

Deckhouse volume is constrained primarily by stability considerations and by external deck area requirements. If the deckhouse becomes too high, it may not be possible to make the vessel stable. Also a certain amount of free deck area is required in nearly all designs, restricting the horizontal spreading of the deckhouse. At the other extreme, the ship may have excessive stability if too small a deckhouse is installed.

These deckhouse volume restrictions have been included in the model by restricting deckhouse size to be within the limits of past practice. Both an upper and a lower limit are placed on the size of the deckhouse as shown in Figure 12. Upper and lower limits of $0.00150 \times L^3$ and $0.001 \times L^3$, respectively, are used in the Navy's destroyer model (DD-07). The model described here uses upper and lower limits of $0.00163 \times L^3$ and $0.0008 \times L^3$, respectively. The new limits were chosen because they can be seen in Figure 12 to bound data for 11 ships in the data sample as compared to only 4 ships for the limits as used in DD-07. The deckhouse volumes shown in Figure 12 do include uptakes.

The volume in the hull is also estimated in VOLUME. The underwater volume is already available. The first step in determining the above water hull volume is the development of an acceptable sheer line. This step is performed by subroutine SHEER and is discussed in conjunction with that routine.

Once the sheer line and with it the average freeboard have been estimated, the above water volume is found by multiplying the area of the waterplane by the average freeboard and by a factor to account for flare. The total volume in the hull is the sum

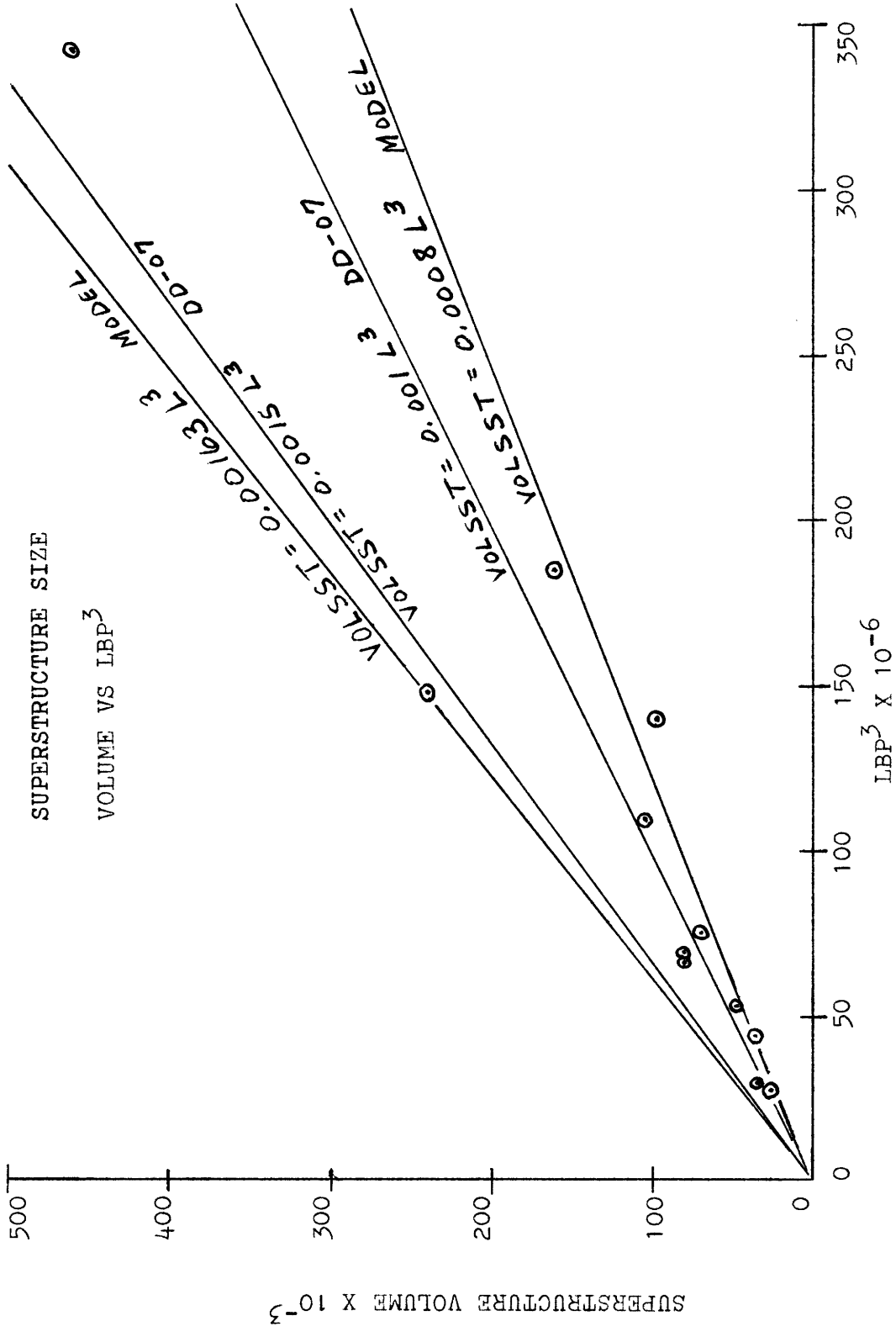

Figure 12

of the above and below water volumes.

The total hull volume includes the volume to the main deck only. The hull volume cannot be reduced below this size but a raised deck can be added to increase the volume of the hull. The model is somewhat limited in that the most that can be added is one raised deck, however, this has proven to be adequate in synthesizing ships from the data base. The deckhouse size can be varied somewhat to change the available volume.

Required hull volume is broken down into three categories. These are the machinery box, tankage volume and arrangements volume. The object of subroutine VOLUME is to alter the available volume so that there is sufficient space for each of the three categories of required volume. The model assumes that all tankage volume and the machinery box volume are in the hull. The deckhouse contains only arrangements volume.

The machinery box size is the first category estimated. This volume is found in one of three ways. The machinery box volume may be found from the estimating relationships provided in Appendix D, or it may be input directly through the input array for volumes, or the machinery box length, beam, and depth may be input in the problem specifications. Machinery box volume is subtracted from the available hull volume to the main deck leaving a volume which can be used for tankage and arrangements.

Some of the remaining volume cannot be used for arrangements because of hull shape. The next step is to estimate the fraction of the remaining volume that can be used only for tankage. This is the minimum tankage volume for the ship. If less tankage

is required for the liquids that must be carried, the excess volume must be used for voids or cofferdams since it cannot be converted into machinery box space or arrangements volume. If more tankage is required than this minimum, some of the arrangements volume must be used for tankage.

The relationships used in the model for flare factor and tankage volume fraction are the same as those used in Reference (8). These relationships were originally taken from work done on the Navy destroyer model.

The weights of all the liquids which must be carried are calculated in subroutine MACHLQ. In VOLUME, these weights are converted to volumes and added together. The volumes required for liquid stowage and other tankage are added together to determine the total tankage volume required. The required total tankage is then compared to the minimum tankage volume to determine the amount of arrangements volume, if any, that is required for tankage.

All of the volume remaining in the hull after tankage volume and machinery box volume have been subtracted can be used for arrangements. The entire superstructure volume is also available for arrangements.

The total arrangements volume available must be compared to the volume required for all the ship's functions plus the volume due to the specified input. The volume required for ship's functions, such as stores, living and maintenance, are estimated in the model based on past practice. The estimating relationships developed for all volumes are given in Appendix D. Volumes are

either input or calculated for all of the appropriate functional groups of Appendix C.

Data was obtained for the volume relationships from References (21) and (22) and from class notes from M.I.T. Course 13.71. The following ships formed the data base from which the volume relationships were developed:

FF-1006	CG-26	DDG-2
FF-1033	DL-2	FFG-7
FF-1037	DL-1	DD-963
DD-692	CGN-35	
DD-931	CGN-9	

All of the required volumes are summed to determine the total required volume. This volume is then compared to the available arrangements volume in the hull and superstructure.

Comparisons are made in the following order. First, the arrangements volume required to be located in the deckhouse is compared to the volume of the largest allowable deckhouse. If the required volume exceeds that available, the design is infeasible and an error message is printed and the ship length is increased by 10 feet to provide a larger superstructure. Next, the total required arrangements volume is compared to the total available volume. If the required volume is the smaller, the deckhouse size is decreased. The deckhouse size used is either the size which balances the volume requirements or the smallest allowable deckhouse size or the volume required to be in the deckhouse, whichever is greatest. Should the total required volume exceed that available a raised deck is added.

The length of raised deck is determined by an iterative procedure. On each iteration the area required to be included in the raised deck is computed and the relationships provided by Reference (8) are used to convert the area to a raised deck length. The curve developed in Reference (8) is based on the main deck of a 378' Coast Guard Cutter and is considered to give satisfactory results for Navy ships. Since the geometry of a cutter closely resembles that of naval combatants (C_{wp} , L/B , B/H , C_p , C_x , etc.), the area distribution with length at the main deck level can be expected to be approximately the same. The iteration continues until two successive iterations fall within 5 percent of the length of the ship or until twenty iterations is reached. In the latter case the design is ruled infeasible.

If the raised deck length lies between 0.4 and 0.6 times the length of the ship, the raised deck is extended to 0.6 times the length of the ship.

As mentioned before, all of the volume estimating relationships were developed using the Navy ships in the data base, however, the general procedure used for the VOLUME subroutine was taken from Reference (8).

3.13 Subroutine SHEER

Subroutine SHEER selects an appropriate sheer line by specifying the freeboard at the forward perpendicular, amidships, and at the after perpendicular. This sheer line must satisfy a number of criteria.

First, there must be sufficient depth amidships to accommodate the engine room. The depth amidships must also be sufficient

to insure adequate structural strength. A minimum value of $L/16$ is used.

The next criterion which must be satisfied is adequate freeboard at the forward and after perpendiculars. Navy derived formulas were used. These formulas give the minimum acceptable freeboard based on a deck wetness criterion.

Once independent determinations of freeboard at the forward and after perpendiculars and at amidships are made, a check is required to insure that a reasonable sheer line can be drawn between the three. Reference (8) indicates that data was obtained from past designs and from standard merchant ship sheer curves. This data was nondimensionalized by subtracting the freeboard amidships from the other freeboard values and then dividing by the length of the ship.

The sheer line is assumed to be practical if the forward sheer fraction lies between 0.01 and 0.03 and the after sheer fraction lies between 0.001 and 0.0075. If this is not the case, one or more of the freeboard values is adjusted until the criterion is satisfied.

If a raised deck is added to the hull, a new sheer line is calculated. It is assumed that the required freeboard of the main deck at the forward perpendicular can be one deck height below that required by the deck wetness criterion. This will result in a flattened sheer line as is common for raised deck vessels.

A flow chart for this routine is shown in Figure 13. Additional details of subroutine SHEER may be found in Reference (8).

SHEER SUBROUTINE FLOW CHART

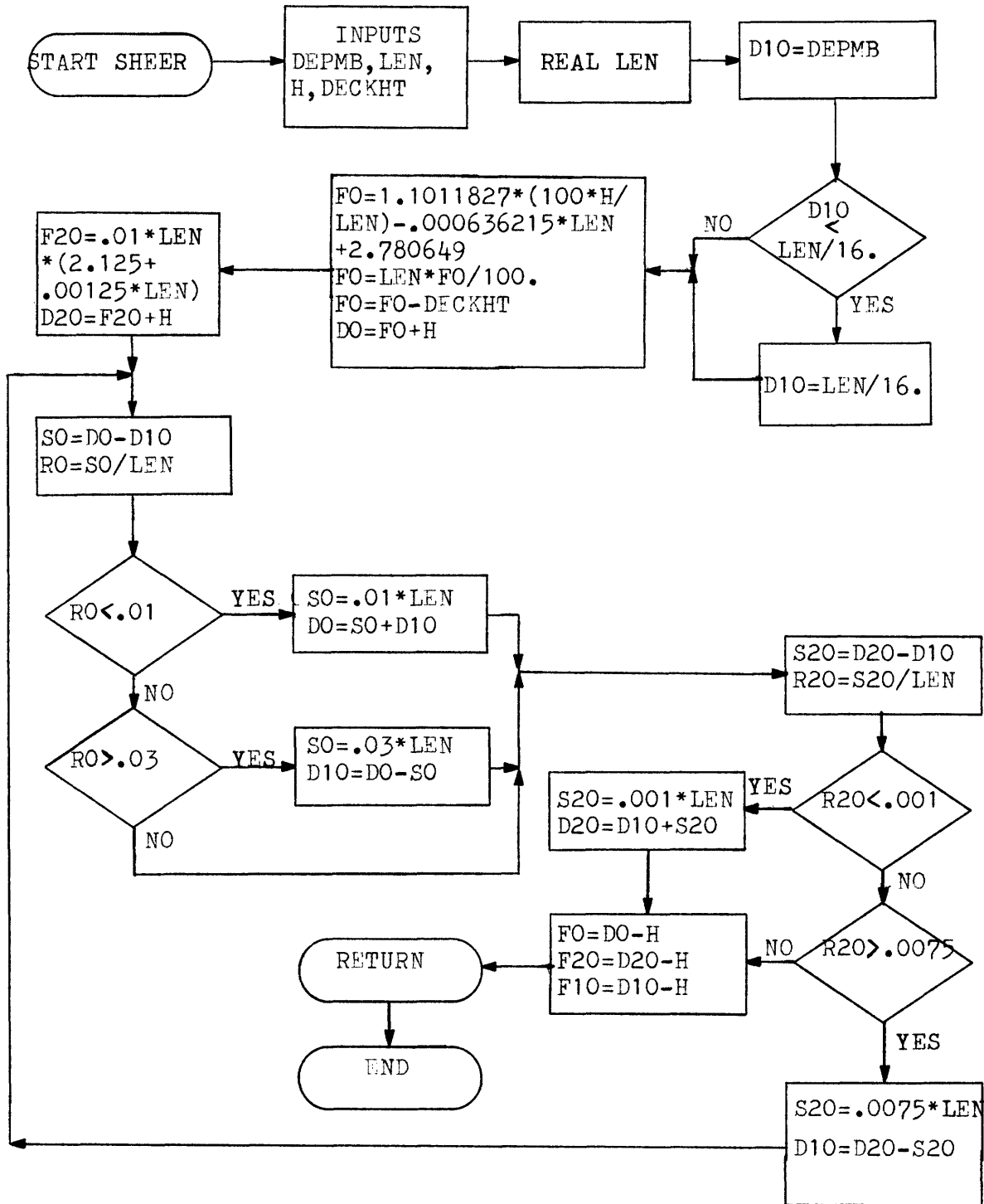

Figure 13

3.14 Subroutine WEIGHT

Subroutine WEIGHT estimates the individual BSCI weight groups for the ship so that a balance can be made between full load weight and displacement. The BSCI was used instead of the currently adopted Ship Work Breakdown Structure (SWBS) of Reference (20) due to the fact that most of the weight data available was in the BSCI form and conversion of ships from SWBS to BSCI listings was considered the simplest. A flow chart for this routine is shown in Figure 14.

Several of the weights required have already been calculated or were given as input. Calculated weights include the liquids which were found in subroutine MACHLQ and the input items calculated in subroutine SPAYLD. Most communications and control weights and armament weights are given as input. The weight groups noted refer to the Modified NAVSHIPS Hull Group Weight Classification as given in Appendix C.

Also given as input are the weights of cargo, aircraft, ammunition, aircraft fuel, and other special payload items. All other weights which are a part of the full load weight are estimated in subroutine WEIGHT. All weights input or calculated are presented at the three digit weight breakdown level.

All weight data, used to develop the weight estimating relationships which are given in Appendix D, was taken from Reference (4). This reference is a complete compilation of weight data for the ships of the weight data base. The original source of all weight data was the weight breakdown sheets prepared for each

WEIGHT SUBROUTINE FLOW CHART

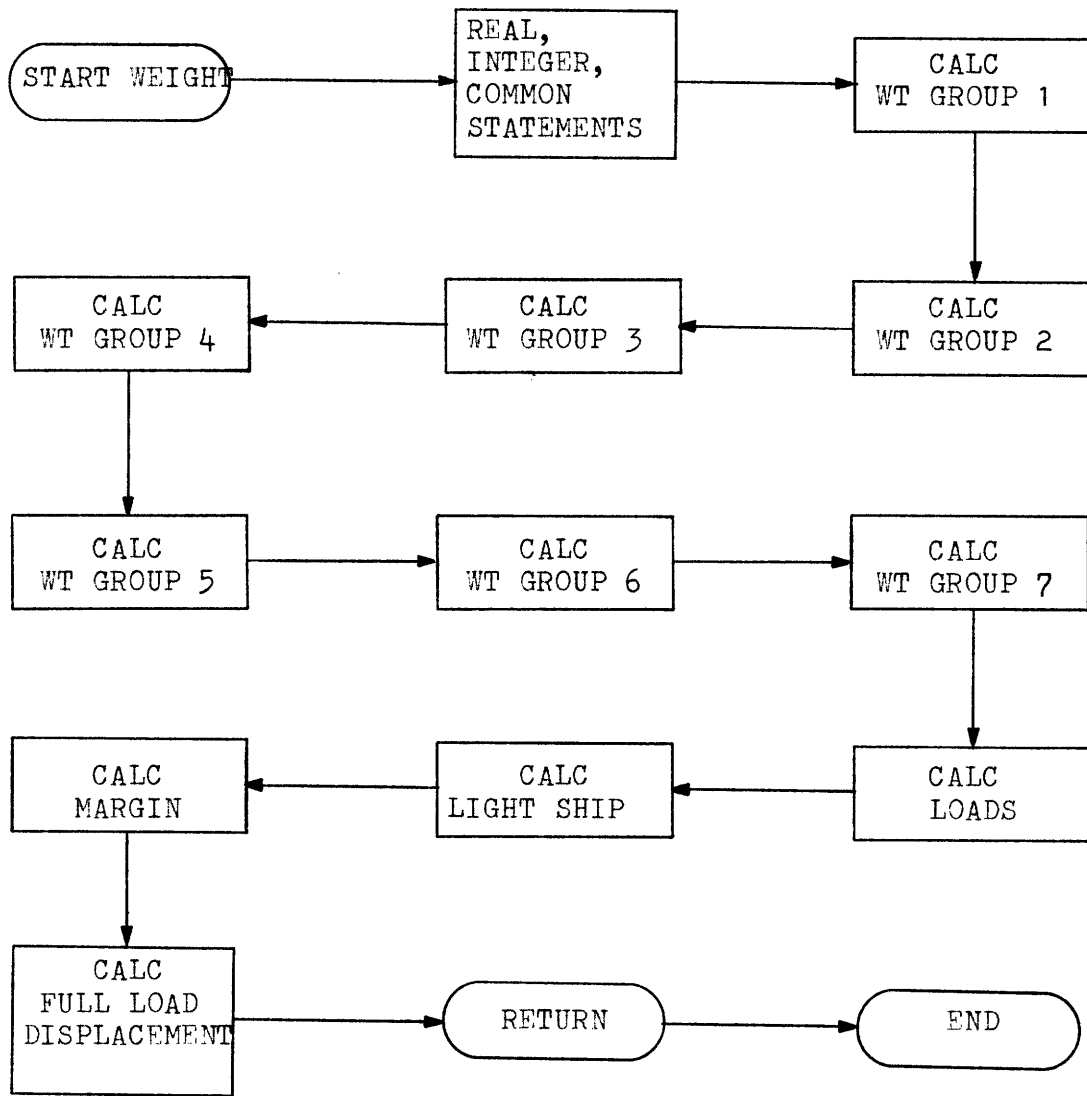

Figure 14

design. The ships used in the weight data base are:

FF-1006	DD-445	CG-9
FF-1033	DD-692	CG-16
FF-1037	DD-931	CG-26
FF-1040	DD-963	CGN-25
FF-1052	DDG-2	CGN-35
FFG-7	DL-1	CGN-36
	DL-2	CGN-9

3.15 Subroutine VRTCG

The vertical center of gravity of the ship is estimated in this routine. Since the designer has some latitude with regard to the location of the center of gravity, the value calculated by this routine should be viewed as a feasible rather than as the best value. A flow chart for the subroutine is given in Figure 15.

The effect that the vcg has on the design can be investigated by using different values of free surface correction. The free surface correction is added to the KG. Therefore, either a positive or a negative value can be used to represent a shift in the KG location.

Subroutine VRTCG estimates a center of gravity for each 3-digit weight group. The vcg for each input item is calculated from input data. The vcg for each non-input function is estimated from the equations provided in Appendix D. The ships used as a data base for estimating the vertical centers are listed below:

FF-1037	DDG-2
FF-1040	CG-26

VRTCG SUBROUTINE FLOW CHART

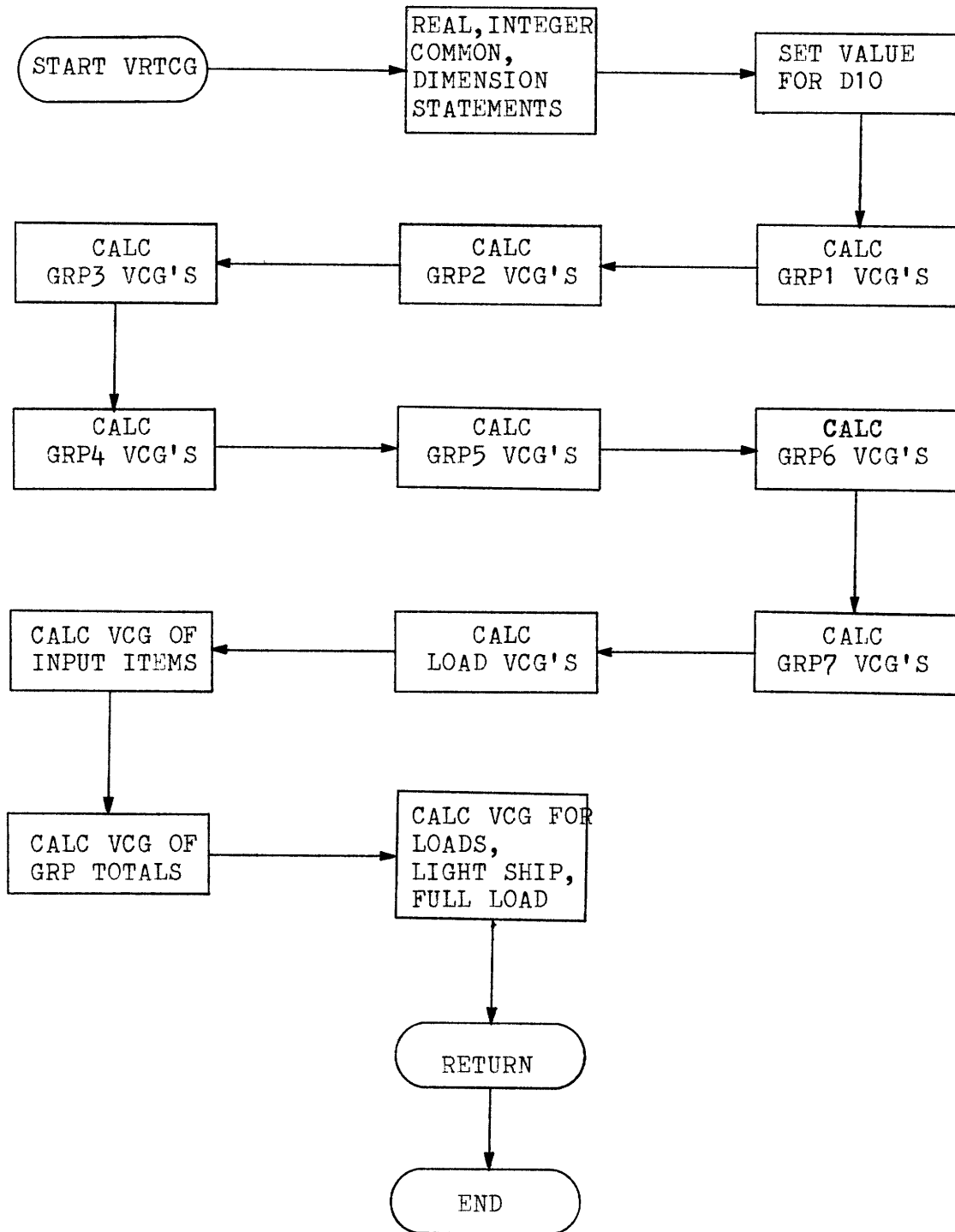

Figure 15

FF-1052

CGN-25

FFG-7

CGN-35

CGN-9

This data base spans a wide range of ship sizes and gives very good predictions for the vcg's.

3.16 Subroutine FNCGRP

The primary function of subroutine FNCGRP is to place the weights calculated for the BSCI groups into the functional groups as defined in Appendix C. Once the weights have been assigned to the appropriate functional group, a volume and weight will have been assigned to each group and a density for each function can be obtained. All of these values will be printed as part of the output. A flow chart for subroutine FNCGRP is given in Figure 16.

This subroutine functions in a straight-forward manner by taking each functional group and obtaining the associated weight and then density as defined in Appendix C. For those weight groups which are listed as applying to more than one functional group, the weights are proportioned among the appropriate groups according to the equations given in the listing of Appendix E.

3.17 Subroutine SEASPD

This routine is based on the work reported in References (18) and (19) and is the identical subroutine as used in Reference (8). In References (18) and (19) a computer program is given for computing the average sea speed. This computer program was altered by dropping the option to use a bow sonar dome and by deleting the read and write statements. The program was also rewritten in ASA

FNCGRP SUBROUTINE FLOW CHART

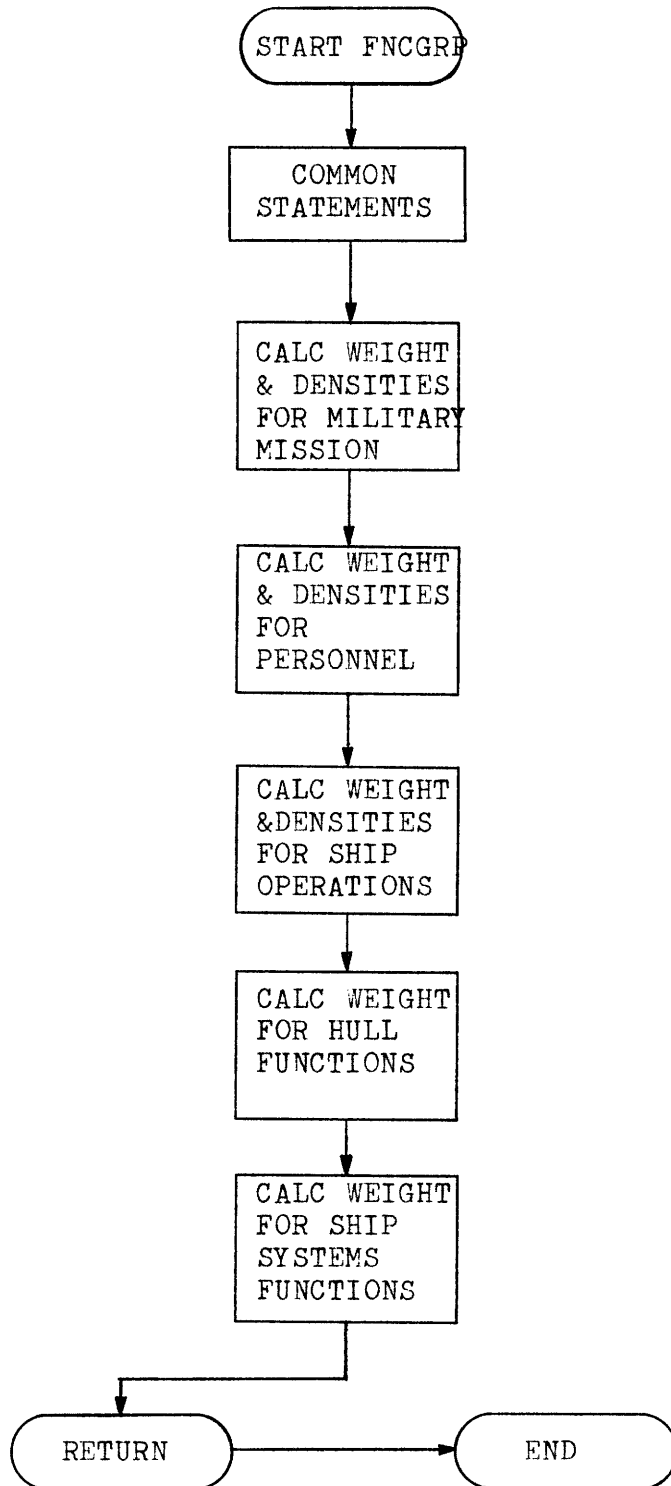

Figure 16

standard FORTRAN. Except for these changes, subroutine SEASPD is the computer program developed in the references. A flow chart for this routine is shown in Figure 17.

Briefly, the routine assumes: (1) that the ship is operating in the North Atlantic Ocean over a long period of time; (2) that it is steaming into head seas one half of the time; and (3) that the remainder of the time (when steaming at other headings) it is not forced to reduce speed due to ship motions. The part of the time the ship is steaming into head seas, its speed will be limited by the sea state. In the routine this is simplified to a single sea state limited speed. The remainder of the time the ship is assumed to be able to make its maximum sustained speed. The percentage of the time the ship is limited in speed is estimated based on average wave heights in the North Atlantic Ocean and on ship characteristics.

The average speed at sea is calculated assuming that the vessel will travel at its maximum sustained speed whenever it is not limited in speed by the sea state. When the vessel is steaming at headings other than into head seas, its speed is not limited. This is assumed to be one half of the time. When steaming into head seas its speed will be limited only part of the time. Both the limiting speed and the percentage of time that it applies are calculated in SEASPD.

This routine has been included to indicate the effect that changes in the vessels characteristics will have on its seakeeping ability. The many assumptions made in deriving the average sea speed limit the usefulness of the speed predicted. However, the

SEASPD SUBROUTINE FLOW CHART

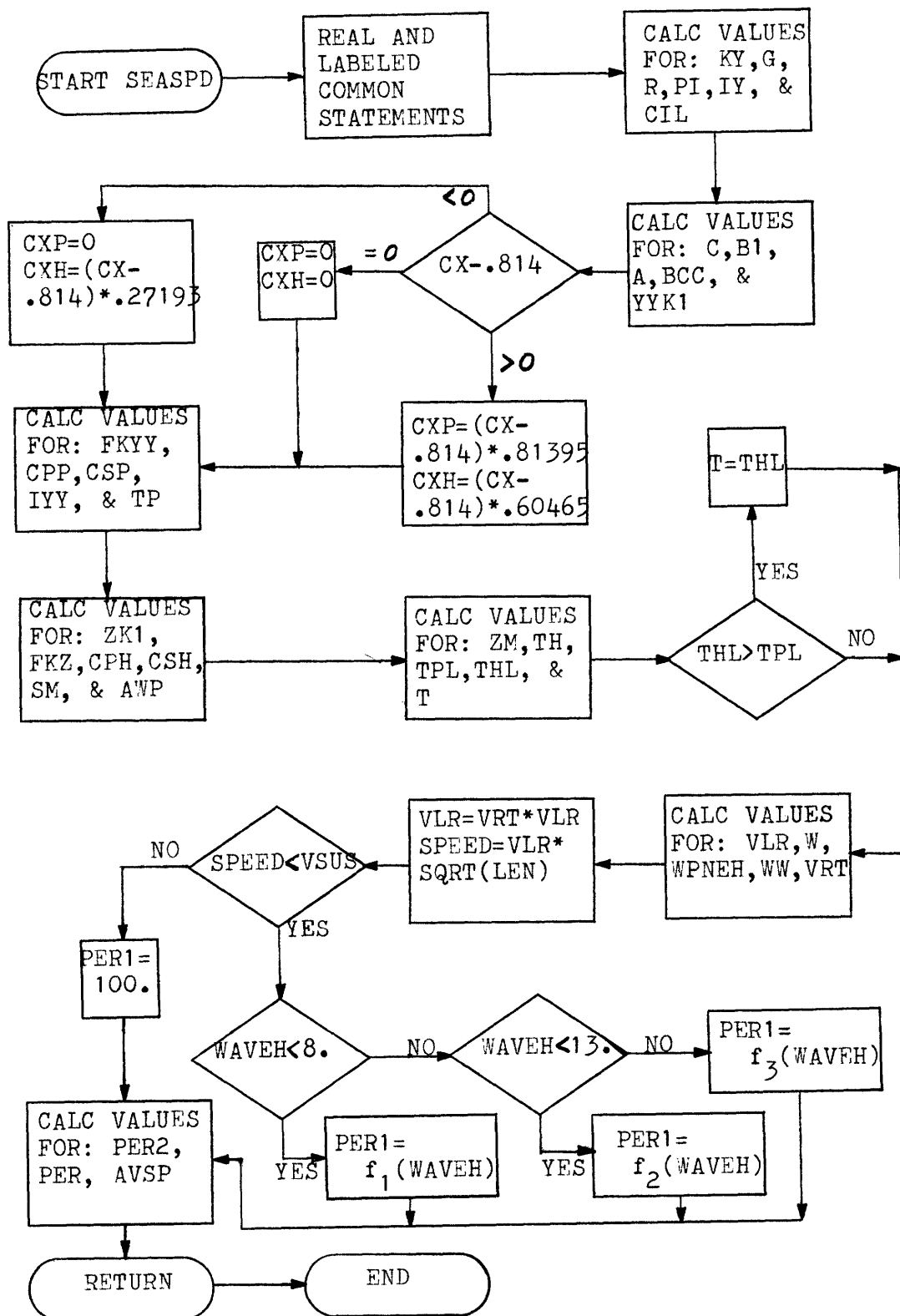

Figure 17

speed calculated can be used to compare two designs to decide which will give the better seakeeping performance.

For additional details of this routine the reader should refer to References (18) and (19).

3.18 Subroutine OUTPUT

All program output is printed by subroutine OUTPUT with the exception of error messages and some default options in the MAIN program. A simplified flow chart for this routine is shown in Figure 18. Subroutine OUTPUT is used to print the input data and the output generated to the degree specified by problem specifications 72 and 73 which are defined in Appendix A.

Subroutine OUTPUT consists primarily of print and format statements. Some calculations are made but only to convert previously calculated values to a desired output form, such as, determining several ratios which are output.

The only decision points used are to determine the amount of output to be printed. These decision points are shown in the flow chart.

OUTPUT SUBROUTINE FLOW CHART

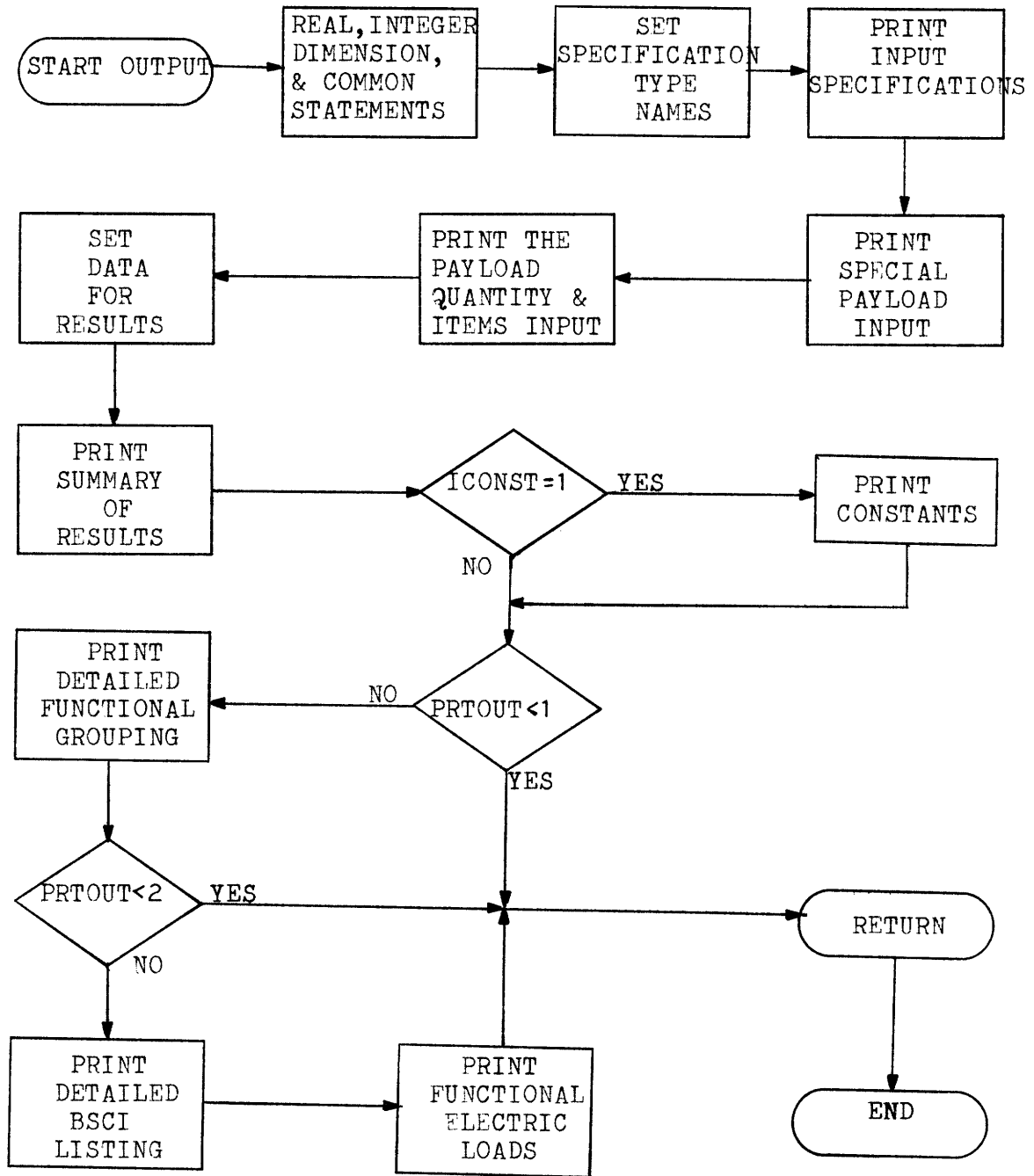

Figure 18

CHAPTER 4

RESULTS OF MODEL APPLICATION

4.1 Introduction

As a basis for evaluating the accuracies and versatility of the model, this chapter provides particular results from using the model to synthesize several surface ships over a wide range of size. Both data sample ships and non-data sample ships were tested. The test runs were made on the IBM 370, model 168, computer located in the Information Processing Center at M.I.T.

Section 4.2 discusses results obtained when using the model as a conceptual design tool. During the conceptual design phase, many combinations of input variables are generally tried before the specific features of the ship are selected. Once specific features, e.g., length, horsepower, individual weight and volume groups, and accommodations, have been selected the model may be used with these known parameters to provide a design update with increased accuracy in overall results. Use of the model to provide a design update is presented in section 4.3.

Since the model allows for the input of specific weight and volume groups and habitability standards, it may also be used as a tool for comparative naval architecture studies. An example of the model used as a comparative tool would be designing the FF-1052 to Soviet design standards. Results of this application and others are presented in section 4.4.

Section 4.5 is provided to give an overall assessment of the results and how they should be interpreted and used.

4.2 Model in Conceptual Phase

A comparison between results produced by the model and the actual ships is given in Table 3. All of the ships compared in this table except for one, the FFG-2, were in the data sample used.

Model predictions of Table 3 are the result of input specifications which assumed the ship designs to be in the early conceptual phase, therefore, the large percentage difference for some of the ships was expected. The only input specifications reflecting the actual ship were:

LBP	Accommodations
VSUS	C _p
Payload Items	C _x
Endurance	Duration
Type Propulsion Plant	Type Electric Plant

The program was allowed to make the standard calculations for all weight and volume groups and to size the propulsion and electric plants. Since the standard calculations built into the model reflect what is probably the "average" ship over the past 20 years, the results for the ships built during the mid 1960's with few special features, e.g., FFG-2, FF-1040, and CG-26, are good for this level of input.

For the ships which differ considerably from the model predictions, special features can be identified to account for the major portion of the difference. For example, if the habitability standards used by the model to predict the FFG-7 and DD-963 were increased from the model standard to current standards, the predicted results would improve.

SHIP	FULL LOAD DISPLACEMENT		INTERNAL VOLUME		BEAM		DRAFT		DEPTH		KG				
	DATA	MODEL	DIFF	%	DATA	MODEL	DATA	MODEL	DATA	MODEL					
FF 1003	1770	1647	- 6.9		242397	254181	+ 4.9	37	38.7	12	10.3	28	29.2	14.1	17.1
FFG 2	3412	3400	- 0.4		363583	406118	+11.7	44.2	40.9	14.7	15.8	30.5	30.0	*	16.0
FF 1040	3371	3494	+ 3.6		*	399728	*	44.2	41.0	14.3	16.2	30.5	30.7	*	16.0
FFG 7	3585	3013	-16.0		516452	368999	-28.6	45	39.7	14.4	14.5	30.0	27.2	18.6	16.5
FF 1052	3934	3507	-10.9		481020	402596	-16.3	46.7	40.3	14.9	15.2	29	28.6	16.6	15.6
DDG 2	4525	5577	+23.2		517946	583399	+12.6	48	49.0	15	17.6	25	33.4	17.0	18.3
DD 963	7644	6408	-16.2		1046839	688137	-34.3	55	47.8	18	19.0	42	35.4	22	18.4
CG 26	7828	7720	- 1.4		*	797922	*	54.8	50.7	18.8	20.0	38.4	37.4	19.5	19.2
CGN 9	16294	12680	-22.2		1959652	1599624	-18.4	73.2	65.0	24.3	20.1	46	43.8	*	25.8

Note: In the model predictions above only VSUS, LBP, and payload were specified. The program was allowed to make standard calculations for all unknowns.

*Data Not Available

TABLE 3
COMPARISONS OF CALCULATED AND ACTUAL
CHARACTERISTICS--CONCEPTUAL PHASE

In general, the full load displacement predicted will vary from the actual ship data in the same manner as the internal volume difference varies. As an example, the model prediction for the DDG-2 is approximately 1000 tons more than the actual ship in full load displacement. The volume predicted is also too high by about 66,000 cubic feet. Most of the error in the prediction can be found in weight groups 1, 2, 5, and 6 with over predictions of approximately 500, 100, 100, and 50 tons, respectively. This accounts for about 750 of the excess 1000 tons with the remaining 250 tons spread over the remaining weight groups. Calculations for the weight of groups 1, 5, and 6 are highly dependent upon the internal volume of the ship. When the volume is reduced to near the actual value, as can be seen in the next section, the predictions for these weight groups decrease and a much better prediction is obtained. The excess volume predicted for the ship is the result of the model assigning the freeboard to be approximately 5 feet greater over the length of the ship than the actual freeboard. This 5 foot of freeboard difference accounts almost entirely for the 66,000 cubic feet over prediction. It should be noted that the DDG-2 is probably the most volume critical ship in the data base.

Once characteristics and standards for the ship are selected as the design process continues, these specified features may be input to the model to provide a design updated prediction which would more closely predict the final ship. The results of this application are presented in the next section.

4.3 Model Used to Update Design Predictions

Since the model provides the option of specifying weights, volumes, vcg's, and electrical loads, in addition to accommodating payload changes and habitability standards, it offers the capability to update ship predictions as the design features become fixed. To illustrate the model use to update predictions, Table 4 is provided. In this table the same ships are presented as in Table 3 with the addition of the CGN 25. The inputs to the model for this run were more specific with the following features input:

LBP	Accommodations
Installed SHP	C_p
Payload Items	C_x
Endurance	Duration
Type Propulsion Plant	Type Electric Plant
Habitability Standards	Size Electric Plant
Ammo Weight	Weight Groups 200 & 201

The overall results are shown in Table 4a. It can be noted that the differences between model prediction and ship data are now much less than those of Table 3. These results were expected since the new inputs better define the actual ships.

The results of Table 4a were improved over those of Table 3 mainly because installed SHP, habitability standards, and electric plant size were input. In a few instances the percent difference for full load displacement was then changed from a minus value to a plus value or vice versa. One of the reasons for this occurring is that the SHP and installed KW were input for the results of Table 4, but were estimated by the program based on VSUS and other variables

SHIP	FULL LOAD DISPLACEMENT		INTERNAL VOLUME		BEAM		DRAFT		DEPTH		KG	
	DATA	MODEL	DATA	MODEL	DATA	MODEL	DATA	MODEL	DATA	MODEL	DATA	MODEL
FF 1033	1770	1790	242397	269488	37	39.6	12	10.8	28	29.2	14.1	17.2
FFG 2	3412	3702	363583	423274	44.2	42.2	14.7	16.7	30.5	31.7	*	16.5
FF 1040	3371	3621	*	401777	44.2	41.4	14.3	16.6	30.5	31.6	*	16.2
FFG 7	3585	3542	516452	493040	45	42.4	14.4	16.0	30	34.0	18.6	18.4
FF 1052	3934	3879	481020	435294	46.7	42.0	14.9	16.2	29	30.5	16.6	16.4
DDG 2	4525	4908	517946	521413	48	46.4	15	16.4	25	30.9	17.0	17.4
DD 963	7644	7449	1045839	959192	55	54.2	18	19.5	42	42.1	22	21.0
CG 26	7828	8123	*	866690	54.8	52.1	18.8	20.5	38.4	38.4	19.5	19.7
CGN 25	8519	8751	*	906864	57.9	56.2	19.1	21.6	42	40.3	22.2	22.0
CGN 9	16294	16230	1959652	1950001	73.2	70.0	24.3	23.9	46	43.8	*	27.2

Note: In the model predictions in this table, LBP and payload were specified the same as for Table 3, but also specified were SHP, installed electric plant, habitability standards, ammo weight, and weight of groups 200 and 201.

*Data Not Available

TABLE 4a

COMPARISONS OF CALCULATED AND ACTUAL CHARACTERISTICS--

DESIGN UPDATE

to obtain the results of Table 3. For the ships where the results of Table 3 were within a few percent of the actual full load displacement, e.g., FF-1033, FFG-2, and CG-26, the change in propulsion and electric weights alone could be enough to change the percent difference from minus to plus or the reverse.

For the ship characteristics shown in Table 4a, the results below were noted.

- a. The difference between actual and predicted full load displacement varied from +8.5 to -2.6 percent. However, of the 10 ships modeled, 7 of the estimates were within 4 percent of the actual ship displacement.
- b. The difference between actual and predicted internal volume varied from +16.4 to -9.5 percent. This result is not as bad as it might seem, since ships which have large differences in volume can still have small differences in displacement. For example, the FF-1052 volume difference is -9.5 percent, but the displacement difference is only -1.4 percent. This result occurs because the volume differences are generally the greatest in the functional areas of passageways and access and tankage (voids). These are not very dense functions and addition or loss of volume in these areas have only a minimal effect on displacement.
- c. The largest percent difference in beam was -10 percent. This was for the FF-1052 for which the displacement and volume were also estimated low. In this case the predicted beam would be closer to the actual beam if the displacement and volume were increased.

- d. The largest percent difference in draft was +16 percent. This was for the FF-1040 which was also estimated high in displacement by 7.4 percent. If the displacement was estimated lower, then the draft would also be closer.
- e. The largest percent difference in depth is +24 percent. However, of the 10 ships modeled, 8 of the estimates were within 5 percent of the actual depth. The ship which differed by 24 percent was the DDG-2 which has an unusually small freeboard.
- f. The largest percent difference in KG was +22 percent for the FF-1033. The KG for the other ships was within 5 percent of the actual value.

Detailed results for the major weight and volume groups are given in Tables 4b and 4c. The differences are reasonably small in most areas with the majority of the weight groups being 5 to 10 percent from the actual values. As was the case in the previous section, the primary cause of the difference is related to overall ship volume, i.e., when the predicted ship volume is too low the weights for groups 1, 5, and 6 will generally be low also. This in turn influences the amount of energy required for the ship and affects weight groups 2 and 3 and some variable load items.

From Table 4b it is noted that the predictions for weight Group 2, propulsion, are within 12 percent for all ships and within 8 percent for all but the FFG-2 and FF-1040. Because of this, the model predictions for weight group 2 are considered to be very satisfactory when the installed SHP is specified.

The results for weight group 3, electric plant, even with the

SHIP	WTGP1		WTGP2		WTGP3		WTGP4		WTGP5		WTGP6		WTGP7		LOADS	
	DATA	MODEL	DATA	MODEL	DATA	MODEL	DATA	MODEL	DATA	MODEL	DATA	MODEL	DATA	MODEL	DATA	MODEL
FF 1033	601	566	224	232	40	56	43	86	144	188	136	166	40	47	516	448
FFG 2	1117	1136	352	394	117	106	289	274	312	302	274	241	111	132	836	1119
FF 1040	1110	1098	352	390	105	101	150	250	313	319	220	229	98	122	931	1110
FFG 7	1247	1186	255	271	207	167	99	131	412	345	302	260	96	100	834	965
FF 1052	1291	1185	422	456	130	106	294	277	365	351	273	244	145	158	1014	1104
DDG 2	1218	1501	831	786	122	106	176	171	375	408	271	299	258	290	1248	1347
DD 963	3081	2621	767	780	263	248	358	365	708	622	459	450	147	135	1861	2228
CG 26	2356	2579	944	968	221	281	372	450	615	631	425	439	320	351	2575	2424
CGN 25	2992	3026	2325	2390	521	477	398	391	573	591	446	484	389	391	775	1000
CGN 9	6562	6488	3571	3576	754	741	866	710	1028	1078	966	939	958	933	1469	1764

TABLE 4b

DESIGN UPDATE--WEIGHT COMPARISONS

SHIP	MILITARY MISSION VOLUME		PERSONNEL VOLUME		SHIP OPS VOLUME		SUPERSTRUCTURE VOLUME		HULL VOLUME	
	DATA	MODEL	DATA	MODEL	DATA	MODEL	DATA	MODEL	DATA	MODEL
FF 1033	24066	46851	74595	82726	143735	139912	26824	53914	213310	215574
FFG 7	97799	89288	111293	111150	304520	292602	82113	110705	434339	382335
DDG 2	104796	81024	130632	149078	282517	291311	70226	106636	441719	414777
DD 963	163500	159092	194061	164977	689278	635124	211152	241298	835687	717894
CGN 9	602602	611671	447179	461245	909875	877095	458567	550095	1499428	1399907
FFG 2	83383	105252	101000	109122	179200	208901	*	91133	*	332141
FF 1052	109052	107792	116538	109017	255430	218484	*	89200	*	346094

*Data Not Available

TABLE 4c

DESIGN UPDATE--VOLUME COMPARISONS

plant installed KW specified, are on the average about 20 percent from the actual values. Most of the difference can be traced to the results for group 300, electric power generation. This estimating equation may require some modifications. Also, some of the difference is caused by the total internal volume prediction being different from the actual value, since weight groups 302 and 303 are estimated in the program as functions of the internal volume. However, most of the error in the weight group 3 prediction could be eliminated by input of weight group 300 directly into the program once the electric plant has been selected and this weight is known.

The weights for groups 4 and 7 of Table 4b and the volumes for military mission in Table 4c are determined primarily from values input from the payload shopping list. In some cases the predicted values are very close and in other cases the values predicted are off by as much as 100 percent, i.e., weight group 4 for the FF-1033. There are two reasons for the errors which occur. First, some of the data in the shopping list may need modification to reflect better the values required on existing ships. Second, the payload list input to the program for each ship may have been incorrect. In a few instances data on the exact payload for the ship was not available and an estimated payload was used, e.g., number of rounds of ammunition. In general, the results for weight group 7 were closer than those for group 4.

The model prediction for the total weight of load items is in most cases 10 to 20 percent too high. One reason for this is that the model seems to consistently predict the fuel required too high by the same 10 to 20 percent. This would not account for all of the

difference, but would account for a significant portion, i.e., up to 50 percent. The calculations for fuel and diesel oil should be reviewed and could be improved upon.

As a next iteration, more of the individual weights and volumes could be input than was done to obtain the results of Table 4 and even greater accuracy would be expected.

Reference (8) presents a comparison between the actual ship, DD-07, and the Coast Guard Cutter Model for the Navy's Patrol Frigate (FFG-7) design. These results are presented in Table 5 along with the model predictions of Table 4. The input specifications for all of the model predictions of Table 5 are to nearly the same level of detail. It should be noted that the actual ship data and the model prediction reflect an installed electric plant of 4 diesel generators while the Cutter and DD-07 predictions reflect only a 3 generator plant as originally planned. The model results compare favorably with DD-07 and Cutter output.

The results presented in Reference (3) compare actual full load displacement to CODESHIP model results for a number of ships over a wide range of sizes. Six of these same ships have also been predicted by the current model. A comparison between the results of the two models is given in Table 6. As was the case above, the level of input is approximately the same. The model generally gives better results than CODESHIP when predicting ships in this size range. However, the CODESHIP model is built on a data base which includes ships which range in size from small patrol craft to aircraft carriers. The CODESHIP model is intended to synthesize ships of all sizes and types for conceptual analysis and for comparing

TABLE 5
 COMPARISON OF MODEL RESULTS TO THE ACTUAL SHIP,
 C.G. CUTTER MODEL, AND DDO7 MODEL
 FOR THE FFG-7 DESIGN

	LBP ft	BEAM ft	DRAFT ft	DO ft	D10 ft	D20 ft	DAVG ft	DISP. tons
SHIP	408	45.0	14.4					3585
MODEL*	408	42.4	16.0	33.9	25.5	26.7	35.2	3548
DDO7	405	46.7	15.3	41.0	34.0	34.8	35.3	3766
CUTTER	405	46.0	15.3	41.1	28.9	29.3	31.0	3706

WEIGHTS

	<u>SHIP</u>	<u>MODEL</u>	<u>DDO7</u>	<u>CUTTER</u>
WTGP 1	1247.3	1185.7	1331.2	1199.6
WTGP 2	254.6	270.6	240.0	258.0
WTGP 3	207.0	166.5	156.6	211.2
WTGP 4	99.3	131.3	70.7	70.7
WTGP 5	411.6	345.4	381.3	317.5
WTGP 6	302.2	260.4	238.0	333.8
WTGP 7	96.1	99.8	85.7	85.7
WTLSHIP	<u>2618.1</u>	<u>2510.7</u>	<u>2503.5</u>	<u>2476.5</u>
LOADS	833.8	965.3	1100.5	1070.2
MARGIN	<u>133.5</u>	<u>123.0</u>	<u>162.9</u>	<u>161.0</u>
	<u>3585.4</u>	<u>3548.0</u>	<u>3766.9</u>	<u>3707.7</u>

* Model prediction has 8.5' raised deck for 387 ft.

TABLE 6
 COMPARISON OF MODEL AND CODESHIP RESULTS FOR
 FULL LOAD DISPLACEMENT

SHIP	<u>DATA</u>	<u>MODEL</u>	<u>MODEL % Diff</u>	<u>CODESHIP</u>	<u>CODESHIP % Diff</u>
FF 1040	3371	3621	+7.4	3643	+ 8.1
FFG 2	3412	3702	+8.5	3698	+ 8.4
FF 1052	3934	3879	-1.4	3991	+ 1.4
DDG 2	4525	4908	+8.5	5269	+16.4
CG 26	7828	8123	+3.6	8700	+11.1
CGN 25	8519	8751	+2.7	8262	- 3.0

cost and technical results not necessarily accurate in absolute values.

4.4 Model as a Comparative Tool

Another possible use for a versatile design model would be as a tool for comparative naval architecture studies. In Reference (11), Captain Kehoe suggests differences in design standards for warship design between the Soviet and U. S. Navies. Applying the suggested standards to the FF-1052, but keeping the payload, installed SHP, and accommodations of the originally designed ship, the new ship was synthesized to the standards listed in Table 7. The results for weight and volume (Table 7) indicate a smaller, faster, and denser ship would be realized at the expense of reduced habitability, endurance, maintenance, and access. This result is as expected and seems to be a reasonable estimation of the redesigned ship.

The reduced habitability standards can be input using the miscellaneous specifications described in Table 18 of Appendix A. To reduce the habitability standards by 40 percent of conventional U. S. practice, a value of 0.6 could be entered for the habitability related coefficients of Table 18. The reduced volumes for the bridge, offices, machinery box, ventilation, maintenance, and passage-way and access were directly input to the program by taking the appropriate percentage of the model predicted FF-1052 volumes. The reduced deck height and endurance were directly input to the program.

As a second example, the FF-1052 was modeled as if it had

TABLE 7

FF 1052 TO SOVIET DESIGN STANDARDS

FUNCTIONAL GROUP CHANGES

Military Mission (Payload)	FF-1052 as ORIGINALLY DESIGNED
Personnel	Reduced habitability space by approx. 40%
Ship Ops	Reduced bridge and office space Reduced machinery box volume by 20% Reduced ventilation space & weight Reduced maintenance space by 50% Reduced passageway & access by 30% Reduced between deck height to 8 ft. Changed endurance to 3500 miles

SHIP COMPARISONS

	WEIGHTS (tons)				VOLUMES (cu ft)	
	<u>DATA</u>	<u>FF 1052 CALC BY MODEL</u>	<u>FF 1052 TO SOVIET STANDARDS</u>		<u>FF 1052 CALC BY MODEL</u>	<u>FF 1052 TO SOVIET STANDARDS</u>
WTG1	1291	1185	1022	Military Mission	107792	96022
WTG2	422	456	454	Personnel	109017	78610
WTG3	130	106	101	Ship Ops	<u>218484</u>	<u>180415</u>
WTG4	294	277	271	Total	435293	355046
WTG5	365	351	293	Superstructure	89200	59270
WTG6	273	244	204	Hull	346094	304178
WTG7	145	158	158			
Loads	<u>1014</u>	<u>1104</u>	<u>908</u>			
Full Load	3934	3881	3411			

been designed to estimated Soviet mission requirements and design practices. The changes made to produce the Sovietized FF-1052 were taken from Reference (11) and are given in Table 8. These changes in standards were also handled by directly inputting appropriate weight and volume groups and the new payload list and problem specifications. The resulting ship characteristics are given in Table 9. The model predicts the Sovietized FF-1052 to be even lighter than the ship of the previous example. This result seems reasonable due to the greater impact on the ship of the FF-1052 payload as compared to the Sovietized payload with twice as many payload items. The SQS 26 Sonar and 5"/54 Rapid Fire Gun are much higher impact items than the individual components of the Sovietized weapon suit.

The model may also be of assistance in estimating the characteristics of ships for which little data is available. As an example of the model used in this manner, the Soviet "Kara" Class CG was estimated. Inputs for the model were those given in Reference (11) with the Soviet weapons suit being input as comparable items from the payload shopping list. The input for the Kara run is listed at the end of the computer listing in Appendix E. The estimated Kara Class characteristics are given in Table 10.

As a final comparative example, the FFG-7 was synthesized using design standards characteristic of the high performance ships, i.e., hydrofoils and surface effect ships. The inputs to the model were the same as those the FFG-7 presented in earlier results with the following changes:

- a. length was not specified (L/B and B/H specified);

TABLE 8

SOVIETIZED FF-1052

<u>Functional Group</u>	<u>Changes</u>
Military Mission (Payload)	<p>Changed Major Payload Items to:</p> <p>5"/54 Lw Gun MK 22 Tartar 2 Harpoon Canisters MK 74 GMFCS MK 87 GFCS SPS-52 Radar ASMD Suite 2 MK 32 T/T D/M Redeye ASROC Launcher 2 CIWS Helo Hangar VDS SQS 23 Sonar</p>
Personnel	Reduced habitability space by approx. 40%
Ship Ops	<p>Reduced bridge and office space Reduced machinery box volume by 35% below standard program value for same horsepower Reduced ventilation space and weight Reduced maintenance space by 50% Reduced passageway & access by 30% Reduced between deck height to 8 ft. Changed endurance to 3500 miles Increased speed to 33 knots Increased number of shafts to 2 Increased number of boilers to 4</p>

TABLE 9

SOVIETIZED FF-1052 CHARACTERISTICS

<u>Characteristic</u>	<u>Value</u>
LBP	420 feet
Beam	39.6 feet
Draft	14.6 feet
Depth @ station 0	39.9 feet
Depth @ station 10	27.3 feet
Depth @ station 20	27.8 feet
C _p	.577
C _x	.812
VCG Full Load	15.4 feet
Endurance @ 20 kts	3500 nm.
Sustained Speed	33 knots
Sustained SHP	44,648 SHP
KW Installed	2600 KW
Displacement Full Load	3299 tons
Displacement Light Ship	2409 tons
Variable Loads	890 tons
WTGP 1	1010 tons
WTGP 2	498 tons
WTGP 3	89 tons
WTGP 4	175 tons
WTGP 5	295 tons
WTGP 6	200 tons
WTGP 7	142 tons
Total Internal Volume	353,612 cu.ft.
Superstructure Volume	59,270 cu.ft.
Hull Volume	294,342 cu.ft.
Military Mission Volume	77,251 cu.ft.
Personnel Volume	78,610 cu.ft.
Ship Ops Volume	194,671 cu.ft.
Accommodations	245
Payload Volume Fraction	0.22
Personnel Volume Fraction	0.22
Ship Ops Volume Fraction	0.56
Payload Weight Fraction	0.13
Personnel Weight Fraction	0.05
Ship Ops Weight Fraction	0.47
Ship Density Full Load	20.90 lbs/cu.ft.

TABLE 10

ESTIMATED SOVIET KARA CLASS CHARACTERISTICS

<u>Characteristic</u>	<u>Value</u>
Sustained Max Speed	34 Knots
Endurance Speed	20 Knots
Endurance Range	8750 n.m.
Max Sustained SHP	95,115 SHP
LBP	538 ft.
Beam	51.8 ft.
Draft	20.8 ft.
Depth @ Station 0	54.9 ft.
Depth @ Station 10	38.8 ft.
Depth @ Station 20	39.3 ft.
VCG Full Load	19.4 ft.
Displacement Full Load	8498 tons
Displacement Light Ship	5539 tons
Variable Loads	2959 tons
WTGP 1	2758 tons
WTGP 2	741 tons
WTGP 3	319 tons
WTGP 4	259 tons
WTGP 5	585 tons
WTGP 6	444 tons
WTGP 7	433 tons
Total Internal Volume	867,135 cu.ft.
Superstructure Volume	144,461 cu.ft.
Hull Volume	722,674 cu.ft.
Ship Density Full Load	21.95 lbs/cu.ft.
Payload Volume Fraction	0.17
Personnel Volume Fraction	0.24
Ship Ops Volume Fraction	0.59
Military Mission Volume	150,194 cu.ft.
Personnel Volume	205,558 cu.ft.
Ship Ops Volume	511,383 cu.ft.
Accommodations	540
Payload Weight Fraction	0.09
Personnel Weight Fraction	0.05
Ship Ops Weight Fraction	0.48

- b. high speed diesel electric plant specified;
- c. aluminum hull material selected;
- d. centerline passageway type selected;
- e. weight group 201 reduced by 50 tons to allow for eliminating gas turbine enclosure and other items not required on high performance vehicles;
- f. weight group 203 reduced by 50% to account for planetary gears and light weight bearings and shafting;
- g. machinery box volume reduced by 10%; and,
- h. deck height for payload items and raised deck reduced to 8.0 feet.

The resulting characteristics for the high performance designed FFG-7 are listed in Table 11. The model estimates the new design as only 2634 tons with an increase in speed to 33 knots. This is with no reduction in personnel volume, but a reduction in total ship volume of approximately 20%. The resulting model prediction should be a technically feasible ship design, since the inputs to the model represent features which are currently within the state-of-the-art in shipbuilding. Many high performance indices, which would reduce the size of the ship even further, were not considered due to the uncertainties in incorporating these into a conventional displacement hull design.

4.5 Assessment of Results

The model results are considered to be good for conceptual phase estimating of ships in the size range of the data sample. The data sample ships ranged in size from the 301 ft./1770 ton FF-1033 to the 700ft./16,294 ton CGN 9.

TABLE 11

CHARACTERISTICS OF FFG 7 DESIGNED TO
HIGH PERFORMANCE SHIP STANDARDS

<u>CHARACTERISTIC</u>	<u>HIGH PERFORMANCE FFG-7</u>	<u>MODEL FFG-7</u>
Max. Sustained Speed, knots	33.0	30.5
Sustained Speed SHP	40,000	40,000
LBP, ft.	382	408
Beam, ft.	40.2	42.4
Draft, ft.	13.4	16.0
C _p	.593	.593
C _x	.747	.747
VCG Full Load, ft.	17.8	18.4
GM/B	0.08	0.08
Average Depth, ft.	31.0	35.2
Accommodations	185	185
KW Installed	4000	4000
Full Load Displacement, tons	2634	3548
Light Ship Displacement, tons	1666	2460
Variable Loads Weight, tons	886	965
WTGP 1, tons	595	1186
WTGP 2, tons	191	271
WTGP 3, tons	113	167
WTGP 4, tons	123	131
WTGP 5, tons	295	345
WTGP 6, tons	249	260
WTGP 7, tons	100	100
Total Internal Volume, cu.ft.	392,500	493,040
Hull Volume, cu.ft.	301,660	382,335
Superstructure Volume, cu.ft.	90,840	110,705
Full Load Ship Density, lbs/cu.ft.	15.04	16.12
Military Mission Volume, cu.ft.	83,901	89,288
Personnel Volume, cu.ft.	111,050	111,150
Ship Ops Volume, cu.ft.	197,550	292,602
Payload Volume Fraction	0.22	0.18
Personnel Volume Fraction	0.28	0.23
Ship Ops Volume Fraction	0.50	0.59
Payload Weight Fraction	0.13	0.10
Personnel Weight Fraction	0.05	0.04
Ship Ops Weight Fraction	0.47	0.43

The model was built to reflect what were generally the standard features of U. S. ships over the past 25 years. Since the model estimates standard features, the ships predicted by the model at the early conceptual phase level, when only the minimal problem specifications are known, will in most cases be smaller than the actual ships which result. This is because most ships will have some special features which either exceed the standard or for which no standard calculation is provided, e.g., clean ballast system. Some of the features which are generally responsible for size increase are special tankage, increased habitability, and special maintenance and access requirements. This can be seen in Table 3 where ships with few special features, i.e., FFG-2, FF-1040 and CG-26, are predicted very close, but ships like FFG-7 and DD-963 with increased access and habitability requirements are predicted too small. The general trend is that the newer ship designs will have more features which are more demanding than the standard calculations provide, and hence, the newer ships will tend to be underestimated the most.

The results are noted to become more accurate as the input becomes more specific. This was shown in Table 4 where the results became very good with specification of the major ship characteristics which are usually defined early in the design. It is at this point, when the desired standards for habitability, tankage, maintenance, access, etc., have been established, that the model predictions can be made with anticipation of only a small difference from final ship results.

The property of the model which allows increased accuracy

beyond the conceptual formulation is the input array for weights, volumes, vertical centers, etc. It is this feature to update design predictions which would allow for exactly specifying the actual ship if all weights and volumes were input.

When used as a tool for comparative naval architecture, the model gives results which appear to be quite reasonable. The value of the model used in this manner is that it can be used to compare ships for which the design data available ranges from only top level ship characteristics to detailed ship specifications, i.e., Soviet to U. S. ships. When doing comparative studies, whatever information is available for a ship can be directly input to the program. For the case of U. S. ships, the individual weight, volume, vcg, and other special input groups can be directly set into the program to the finest level of detail used in the program and available in the data. The results for this type of ship prediction should be very accurate. For ships where little data is available, the problem specifications, payload items, and any desired special features can be input based upon engineering judgment, any data available, or a best guess. In any case the results should be examined for reasonableness of the prediction.

The model can be used to synthesize ships to certain "design indices". Here design indices refer to a ratio of design impact to capacity, where design impact can be measured as the weight, space, or energy required to provide the specified capacity. To accomplish this for all features an iterative number of runs may be necessary to meet all of the desired indices. After each run the results must be analyzed to determine which inputs should be changed to meet the

desired indices. For example, the machinery box volume per shaft horsepower indice can be met once the installed SHP has been determined by multiplying the two numbers and inputing the result in the input array element for machinery box volume.

The standard relationships used for calculating weights in the program have been found to be very good over the entire range of ships in the data base. This applies to the ships whether large or small in size or old or new in age. Model results have shown that a ship which has the internal volume predicted by the model would have actual weights very close to those estimated by the model standard calculations.

Analysis of model results indicates that the weight required for specific functional items has not changed significantly over the past 25 years; however, the volume required for the same functions has been the driving factor in determining the resulting ship size. In general, it can be said that the full load displacement of a ship carrying a specific payload can vary over a considerable range depending on the volume allocated to the various functional groups. To support this statement, it was found in developing Table 4 that varying the volume for habitability items, tankage, maintenance, and passageways and access, while accepting the standard weight calculations, produced very good results. This seems to indicate that volume requirements in these areas have been those which have deviated from standard practice the most and are the areas where most of the special features of a design are found.

If it were desired to have the model predict ships using the standards of a certain class of ships, e.g., FFG-7, the model

estimating relations which are based on several ship classes could be changed. This could be accomplished with relatively little difficulty since no change to the program logic would be required. This change would probably increase the value of the input array since modeling ships of a class different from the one the model is based upon may require a more detailed input.

The detailed output of the model could provide a basis for budgeting weights and volumes for beginning the preliminary design phase. Once a concept design has been selected, the preliminary phase is generally handled by a number of design teams working in parallel in areas such as combat systems, mobility, ship support, hull structures, habitability, and ship systems. Each of these groups could be assigned the volume and weight groups associated with their areas of functional responsibility as an initial budget or design guide.

This method of providing an initial budget based on model predictions could result in a more efficient ship design than having each design group start with only gross ship characteristics and providing their own first assessment of what they feel they need. If the design groups find that the budgeted weight and volume are just not satisfactory to provide the required functional capabilities at the desired design standards, the acceptable values can be directly input into the corresponding weight and volume groups of the program to override the calculated values. The model can now be used to provide an updated prediction for the ship reflecting the fixed values input. This would also provide the designer with an indication of how changes in one functional group

may have an affect on another group, e.g., adding weight to any weight group will mean added weight and volume for fuel to attain the same endurance. In any event the designer would have an aid in assessing the impact of design changes at any phase of the design.

CHAPTER 5

CONCLUSIONS AND RECOMMENDATIONS

The synthesis model was found to give results accurate to within about 20 percent when used to predict actual ships using standard input specifications at the level of early conceptual studies. When using this level of input to predict existing ships, the differences between model predictions and actual ship characteristics can generally be explained by special features of the actual ship. Since the model predicts a "standard" value based on the sample data, results at this first and roughest level of modeling will tend to be predicted on the low side. This is true because the model will make its standard estimations considering a ship with essentially no special features.

The computer synthesis model can be used more effectively during the conceptual phase of the design than at any other stage. The model developed in this thesis allows the user to make the same kinds of ship systems level tradeoffs as previous models. Input options are selected for payload and performance features and a series of standard calculations are used to predict the results. The model provides additional versatility at this phase of design, since it enables the designer to directly input values at a more detailed functional level when it is desired to provide features which differ from the standard calculations provided. Results attained when using the model in this manner were shown to be within 5 percent of existing ship values for minimal amounts of additional specification and could be reduced even more if additional items were specified.

The model was also shown to provide a means of conducting comparative studies between ship designs. This is one area where models which can accommodate only one set of design standards cannot be applied. The model used in this manner could be of considerable value when analyzing foreign ship designs where the design standards differ from U. S. practice in most areas. The model can provide a prediction for any existing ship by using specified input values when available and providing the standard calculation if a better value is not available.

Although the synthesis model appears to give accurate results in its current form, there are several areas which are recommended for additional investigation or improvement. The areas which are recommended for future investigation are discussed in the following paragraphs.

With the current limits placed on the C_r array, many ships cannot be run which may be very desirable. Perhaps the best solution to expanding the C_r values available would be the addition of the data from another model test series, such as series 64.

Also, the effect on speed-horsepower predictions caused by sonar domes of modern warships should be included in the horsepower calculating routine. It is felt that the large sonar domes, e.g., SQS 26 bow mounted sonar, could have a noticeable effect on speed-power predictions at both endurance and maximum speeds. The current model does not consider the effects of sonar domes.

It is recommended that the payload shopping list data be modified to include the cruise, battle, and 24 hour electric load requirements for each item. This would be especially desirable

for the items which fall under weight groups 4 and 7 (electronics and armament), since these are the most variable items from one ship to the next and the hardest to predict electric loads for.

Since payload items used on naval combatants are continually changing, the payload shopping list should be reviewed periodically to insure that it is kept up-to-date. Some items on the list will require changes as systems are revised. Other items may lose their value on the list and should be deleted, while new items should be added to the list as they become available.

It would also be desirable to include a routine which would consider the topside deck areas required by payload items and the superstructure. In recent years the Naval Ship Engineering Center has developed a significant capability to relate electronic system performance to topside geometry. Information of this type could be used to help set limits on length and height requirements for the superstructure.

An additional recommendation for future development is the addition of a cost routine to the program. Results attained by the program could be used to predict acquisition cost for a lead ship of the design and costs for follow-on ships. Also, relationships could be derived to predict a life-cycle cost which may be of more interest than the acquisition cost.

The model could be modified to handle changes in hull shape which are considerably different from conventional design practice. The model relationships are based on ships of conventional hull shape. New relationships would be required for most all items due to the effects of an unconventional hull shape on features such as

powering, arrangements, structures, access, etc.

As discussed in Section 4.5, the model can be used to design to indices rather than to gross weight and space values. However, the model requires an iteration of synthesis runs which could be expensive and time consuming. It would be desirable to have a model where design indices could be input with the model iterating a balanced solution satisfying the indices.

The ship synthesis model developed in this thesis is intended to serve only as a design tool, and as such, complete reliance should never be placed in the results attained. However, it is felt that if the results are properly analyzed, the model will enhance the design-engineer's ship-design capability. Since the model is only a design tool, the relationships used in the model must be kept current. The users should conduct a periodic review of empirical relations used to insure that they are in agreement with current design policy.

Finally, as has been recommended for several other synthesis models, it is recommended that the model not be programmed as part of a ship optimization routine. Any optimization criteria selected would in general be difficult to define and may result in more desirable ship characteristics being discarded due to biases built into the criteria. It is felt that an experienced designer could better direct the selection of input combinations to be used based on analysis of the previous results attained.

REFERENCES

1. Abbott, Jack W. and Baham, Gary J. "COGAS--A New Look for Naval Propulsion" *Naval Engineers Journal*, Vol. 86, No. 5, October, 1974, pp. 41-55.
2. Comstock, John P., ed. Principles of Naval Architecture. New York: The Society of Naval Architects and Marine Engineers, 1967.
3. "Conceptual Design of Ships Model (CODESHIP) (U)." Center for Naval Analyses, Research Contribution 159, Volumes I through IV, December, 1971.
4. "Consolidated Weight Listing for Various U. S. Navy Cruiser/Destroyers," Naval Ship Engineering Center, 1975.
5. Cotton, James L. "Fourth Update of CODESHIP Payload Shopping List." Center for Naval Analyses, CNA 662-75, 2 May 1975.
6. "Electric Power Analysis for DLG-9, DDG-2, DEG-1, DE-1052, DDG-FY67, DD-963, FFG-7."
7. Gertler, Morton, A Reanalysis of the Original Test Data for the Taylor Standard Series, David W. Taylor Model Basin Report 806, Washington, D.C.: U. S. Government Printing Office, 1954.
8. Goodwin, Michael J. Ship Synthesis Model for Coast Guard Cutters. Massachusetts Institute of Technology, Department of Ocean Engineering, Thesis, June, 1975.
9. Graham, C. and Hamly, R. "Simplified Math Model for the Design of Naval Frigates." Massachusetts Institute of Technology, Department of Ocean Engineering, Course 13.411 Handout, Lectures 5 through 8, September, 1975.
10. Johnson, Robert S. "Ship Synthesis Models--With Examples." Naval Ship Engineering Center, Hyattsville, Md.
11. Kehoe, Capt. James W., Jr. "Warship Design--Ours and Theirs." *Naval Engineers Journal*, Vol. 88, No. 1, February, 1976, pp. 92-100.
12. Libby, D. A. "A Guide for Estimating the Propulsion Plant Weight for Naval Type Surface Ships." Naval Ship Engineering Center Code 6144, February 1970.
13. Mason, T. W. "Data Subroutine CNA Computer Program 13-655." Center for Naval Analyses Research Contribution No. 14, 26 August 1965.

14. Menz, M. G. "Ship Design Analysis--Machinery Box Estimating Procedures." Naval Ship Engineering Center Memo 6152: MGM:dcd, Ser 131, 29 April 1969.
15. Mills, J. "Feasibility Studies and Ship Synthesis Models." Lectures 7, 8 and 9. Unpublished lecture notes for Professional Summer at M.I.T.
16. Naval Vessel Register/Ships Data Book, Naval Sea Systems Command, Washington D.C., 1 July 1975.
17. "Proposed U.S. Navy Space Classification Manual." Naval Ship Engineering Center, December, 1969.
18. Shen, Michael and Gale, Peter. "A Procedure for Predicting the Speed of Surface Ships in Rough Head Seas." Naval Ship Engineering Center Report No. 6114-71-4, 1970.
19. Shen, Michael, Gale, Peter A., and Walker, Kenneth. "An Improved Procedure for Predicting the Speed of Surface Ships in Rough Head Seas." Naval Ship Engineering Center Report No. 6114-71-8, 1970.
20. "Ship Work Breakdown Structure." NAVSHIPS 0900-039-9010, Naval Ship Systems Command, Department of the Navy, Washington, D.C. 20360, 1 March 1973.
21. Smith, L. C. "Ship Space Classification Data." Ship Concept Design Division, Naval Ship Engineering Center, March, 1970.
22. "Summary of Compartment Volumes and Deck Areas for DD-963." Contract No. N00024-70-C-0275, ID No. DD75-010, Ingalls Shipbuilding, Pascagoula, Mississippi, 12 November 1975.
23. Ward, W. K. "A Method for Estimating the BSCI Group 203 Weight During Concept Formulation and Feasibility Studies." Naval Ship Engineering Center Code 6144, May 1968.

APPENDIX A

USERS GUIDE

APPENDIX A
USERS GUIDE

General

This Appendix is intended to serve as a guide for preparing data and specifications for the computer synthesis model listed in Appendix E. For proper use of the computer model it is mandatory that the data input follow the outline of this Appendix.

Input for the model can be divided into two main groups. The first group containing the data for the list of symbols (names) to be used in the output, the C_r arrays used in estimating propulsion power, and the payload data describing the payload characteristics. The second group contains the data for individual ship runs.

The computer cards for each job run should be set up in the following order:

Control Cards
Main Program
All Subroutines
Control Card for Data Input
Symbol Cards
 C_r Data Cards
Payload Data Cards
Blank Card
Ship No. 1 Specifications
Blank Card
Ship No. 2 Specifications
Blank Card

Ship No. 3 Specifications

Blank Card

Etc.

Ship No. n Specifications

Blank Card

Blank Card

Control Card

The symbol cards and C_r cards are read by the main program and must be in the proper order with no blank cards between them, although some blank cards are included in the symbol data. The payload data is read by subroutine DATA2 and requires the blank card after the last payload item to return control to the main program. The symbol cards, C_r array cards, and payload item cards are read into the program only once and are stored in arrays for use with all test cases run.

The data cards containing the specifications for each ship are also read in by subroutine DATA2 and must be followed by a blank card to return control to the main program to allow calculation for each ship to proceed. Two blank cards are required at the end of the data deck. The first blank card serves the same purpose as the preceding blank cards, i.e., returns control to the main program to calculate ship results. The second blank card indicates that no additional ships are to be calculated and directs program execution to stop.

Data for the symbols, C_r arrays, and payload items is listed following the program listing in Appendix E.

Ship Specification

In order to set the input specifications for each ship to be run, a specification array of 2500 elements is used. It is through use of this input array that the versatility of the program is utilized.

The specifications are numbered for use by the computer. The blocks of the array are divided as listed below:

<u>Blocks</u>	<u>Use</u>
1-99	To define performance, hull, power plant, accommodations, special features, and calculation control.
100-299	For specifying the payload items and quantity.
300-1099	To directly input the weight of any of the BSCI weight groups. This overrides any program calculation.
1100-1899	To directly input the vertical center of gravity of any of the BSCI weight groups. This overrides any program calculation.
1900-2199	To directly input the volume of any of the functional groups of Appendix C. This overrides any program calculation.
2200-2249	To directly input the electric load (cruise, battle, or 24 hour average) for any electric load group. This overrides any program calculation.

2250-2299

For specifying certain miscellaneous program parameters or coefficients.

2300-2500

For inputing any special payload items desired which are not included in the payload shopping list.

The primary specifications for any ship run are those defined as the problem specifications in Table 12. This table lists several options which are available to the user in specifying each ship.

The user should keep in mind while preparing input data for each ship that the program initially sets all elements of the specification array to zero. Therefore, care must be taken to insure a value is input for every appropriate non-zero specification. Also, for each succeeding ship after the first one, the values of the specifications remain the same unless the appropriate element is changed.

The user has the option of selecting either the sustained speed (number 1) or the SHP at sustained speed (number 12). If both are specified, the SHP is used and VSUS is ignored.

The length between perpendiculars, LBP, (number 4) may be selected or values for L/B and B/H must be input. If L/B and B/H are specified, but not LBP, the program will calculate a value for LBP and proceed. However, if LBP is specified the input values for L/B and B/H are ignored and the input LBP is used.

The number of boilers must be specified if conventional steam propulsion is selected. Also, the number of boilers and reactors must both be specified if nuclear propulsion is desired. In all

cases the number of main propulsion engines and number of shafts must be specified.

Values for propeller rpm and diameter may be specified, if desired. If not specified, a calculation is made for each of these variables to allow estimating BSCI weight group 203.

The machinery box dimensions may be input, but it is required that if any one of the dimensions (numbers 21,22 and 23) is input that all three be specified. The machinery box volume may also be input using element number 2121 as explained in the following paragraphs or a calculation will be made by the program.

Propulsive coefficients used in estimating shaft horsepower at sustained and endurance speeds may be input. If not input, values of 0.67 and 0.65 are used, respectively.

The frictional resistance correction factor (number 26) may be specified. This value is used in the horsepower calculation. A value of 0.0004 is used if none is input.

The ship service electric and emergency electric plant types must be specified. Item numbers 33 through 40 may be left as zero if it is desired to have the program size the electric plant. However, if any of items 33 through 40 are specified, then the entire electric plant must be specified, e.g., 4 steam turbine generators at 500 KW each and 2 low speed diesel generators at 300 KW each.

The free surface correction (number 71) may be entered to adjust the KG above or below the average built into the program and may be entered as a positive or negative number.

For other specifications a value should be selected as suggested by Table 12.

Payload specification is accomplished by use of specifications 100 through 299 as shown in Table 13. Up to 100 items may be specified, in any quantity for each item. The quantity is to be given as an even numbered specification, starting at 100. The associated item number is to be given as the next specification in each case.

The program has been developed to allow the user to specifically input any weight group, volume group, center of gravity, or electric load group that may be desired. This capability may be especially useful in later stages of a design as more and more characteristics of the ship become fixed. For example, if the propulsion plant had been selected, the user could directly input most of the BSCI Group II weights. The input weights would override any calculated values and improve the accuracy of the overall ship characteristic estimates. The user should then be able to continually update the prediction of the final ship, until in the end, the entire ship is specified. The specification numbers which correspond to the weights, vcg's, volumes, and electric loads are found in Tables 14, 15, 16, and 17, respectively.

During execution of the program the values of elements 300 through 2249 of Tables 14, 15, 16, and 17 are checked for a non-zero value. Non-zero values found are used; however, if the element is left zero the standard calculation is made to estimate the appropriate item. Because of this feature, if it is desired that a function have the value of zero, a small positive value must instead be input, e.g., to make volume group 311 equal zero, input item 2111 equal to 0.01. The exception to the above is that

volumes for functional groups 100, 110, 120, 130, 200, 210, 220, 230, 300, 310, 320, 330, 340, 350 and 360 may not be specified directly since they are calculated by summing other volumes.

A list of miscellaneous specifications is provided in Table 18. Not all of the elements in this list have been used, and therefore, the capability exists to readily add more items. Elements 2250 through 2273 have been used to reflect desired changes in primarily personnel related area. As shown in Table 18 these elements are used as multipliers or coefficients to change the calculated value of certain volume groups. Table 20 is provided to suggest a range of values which might be used for these elements. The DD 931 and FFG 7 were selected to generally reflect the two extremes in personnel related volumes required (mainly habitability areas) in current U. S. Navy ships. When not input, a multiplier of 1.0 is assigned.

Item 2274 allows for input of the deck height to be used in calculating volumes for payload items and also in computing volumes associated with an added raised deck. If no value is input a value of 9 feet is assumed. Item 2299 is used to input the machinery box prismatic coefficient. When not input, a value of 0.95 is assumed.

Table 19 indicates how special payload items not identified in the payload shopping list at the end of this Appendix may be input. The information required for special items is the same as that of regular payload items. The appropriate weight and volume groups must be entered along with weight, vcg, and area requirements.

Payload Shopping List

A key element in preparing the input for a ship run is the specification of the ship payload items. The list of payload items available for selection is given in Table 21. This list was developed by selecting appropriate items from those available in Reference (5).

While the definition of each payload item is given in Table 21, the characteristic data for each item is found in the payload data listing included in the program listing of Appendix E. Each line of payload data contains the payload item number followed by seven numbers separated by blanks. The data should be interpreted as shown by the following example using payload item 15:

A	B	C	D	E	F	G	H
1,15	408	112	9.8	12.0	1	210	100

where A = item number (15)

B = weight group number (408)

C = functional volume group number (112)

D = item installed weight in tons (9.8)

E = center of gravity location (feet/factor)*(12.0)

F = center of gravity reference index* (1)

G = deck area inside the superstructure (sq.ft.)(210)

H = deck area in the hull (sq.ft.)(100)

* 1 = item location relative to strength deck (feet)

2 = item location relative to keel (feet)

3 = item location as fraction of ship hull depth at station 10.

Example Ship Input

As an example, input data for a ship might look like the following:

```
column 1          column 20
1 0 20 4500 408 0 0 .59 .75 0 0 6 40000 0 0 2 1
17 2 1 0 0 0 0 0 .66 .67 .0005 0 0 0 0 5 4 0 4
35 0 0 0 1000 0 0 .30 0 0 0 2 2 0 0 0 14 15
52 156 0 0 0 45 0 0 0 0 1 2 0 .75 0 10 20
68 .10 20 .05 0 2 0 0 2
100 1 2 1 24 1 27 1 41 1 61 8 64 1 65 1 75
116 1 100 1 102 1 116
312 40.5
1825 17.2
2161 9000 0 13000
2250 1.32
```

Since the ship specifications are read in under subroutine DATA2, Chapter 3 provides the information on how to code the input data. A sample input is given in the listing at the end of Appendix E. In the example above a few selected specifications are:

Item 1	= 0	VSUS not specified
Item 4	= 408	LBP specified
Item 12	= 40000	SHP specified
Item 17	= 2	controllable pitch propeller specified
Item 62	= 2	aluminum superstructure specified
Item 100	= 1	quantity of 1 of item 101 specified
Item 101	= 2	payload item number 2 specified
Item 2161	= 9000	volume of ballast tankage specified

Item 2162 = 0 volume of peak tankage not specified so
will be calculated, but a 0 was entered to
allow item 2163 to be specified as 13000

TABLE 12

PROBLEM SPECIFICATIONS

<u>Number</u>	<u>Definition</u>
1	Sustained speed, knots
2	Endurance speed, knots
3	Endurance range, nautical miles
4	Length between perpendiculars, feet
5	Length-beam ratio (L/B)
6	Beam-draft ratio (B/H)
7	Prismatic coefficient (Cp)
8	Midship section coefficient (Cx)
9-10	Not used
11	Propulsion plant type: <ol style="list-style-type: none"> 1. 600 psi steam 2. 1200 psi steam 3. 1200 psi pressure fired steam 4. nuclear 5. gas turbine 1st generation 6. gas turbine 2nd generation 7. diesel 8. COGAS
12	Sustained speed shaft horsepower, SHP
13	Number of boilers
14	Number of nuclear reactors
15	Number of main propulsion engines
16	Number of shafts
17	Propeller type: <ol style="list-style-type: none"> 1. fixed pitch 2. controllable pitch
18	Shaft type: <ol style="list-style-type: none"> 1. Hollow 2. Solid
19	Shaft RPM (optional)
20	Propeller diameter, feet (optional)
21	Depth of machinery box, feet (optional)
22	Length of machinery box, feet (optional)
23	Beam of machinery box, feet (optional)
24	Propulsive coefficient at endurance speed (optional)
25	Propulsive coefficient at maximum sustained speed (optional)
26	Frictional resistance correction factor, ΔC_F (optional)
27-30	Not used
31	Ship service electric plant type: <ol style="list-style-type: none"> 1. steam 2. gas turbine 1st gen. 3. gas turbine 2nd gen. 4. low speed diesel 5. medium speed diesel 6. high speed diesel
32	Emergency electric plant type: <ol style="list-style-type: none"> 1. gas turbine 1st gen. 2. gas turbine 2nd gen. 3. low speed diesel 4. medium speed diesel 5. high speed diesel

TABLE 12 (continued)

<u>Number</u>	<u>Definition</u>
33	Number of low speed diesel generators (optional)
34	Number of medium speed diesel generators (optional)
35	Number of high speed diesel generators (optional)
36	Number of gas turbine generators (optional)
37	Number of steam turbine generators (optional)
38	KW per diesel generator (optional)
39	KW per gas turbine generator (optional)
40	KW per steam generator (optional)
41	Electric plant design margin (e.g., .30)
42-44	Not used
45	Type of ship heating: 1. steam 2. electric
46	Fin stabilizers desired: 1. no 2. yes
47-49	Not used
50	Ship officer personnel accommodations
51	Ship CPO personnel accommodations
52	Ship enlisted personnel accommodations
53	Flag personnel accommodations
54	Troop accommodations
55	Passenger accommodations
56	Ship accommodations duration, days
57-60	Not used
61	Basic hull material: 1. steel 2. aluminum
62	Basic superstructure material: 1. steel 2. aluminum
63	Not used
64	GM/B stability value (e.g., .10)
65	Not used
66	Tolerance for displacement iterations, tons (e.g., 2)
67	Maximum number of displacement iterations
68	Tolerance for vertical center of gravity iteration, feet (e.g., .1)
69	Maximum number of center of gravity iterations
70	Design, construction margin (e.g., 10% margin entered as 0.10)
71	Free surface correction, feet
72	Print index, number of pages: 0. input plus summary of results 1. above plus functional listing 2. all of above plus BSCI weight groups and elec- tric loads
73	Miscellaneous coefficients print index: 0. don't print constants 1. print constants
74	Not used

TABLE 12 (continued)

<u>Number</u>	<u>Definition</u>
75	Passageway type: 1. centerline 2. port & starboard
76-99	Not used

TABLE 13

PAYLOAD SPECIFICATIONS

<u>Number</u>	<u>Definition</u>
100	Quantity of payload item in 101
101	Payload item number (payload shopping list)
102	Quantity of payload item in 103
103	Payload item number (payload shopping list)
104	Quantity of payload item in 105
105	Payload item number (payload shopping list)
...	
298	Quantity of payload item in 299
299	Payload item number (payload shopping list)

TABLE 14

WEIGHT SPECIFICATIONS

<u>Number</u>	<u>Definition</u>
300	Input of BSCI* Weight Group 100, tons
301	Input of BSCI* Weight Group 101, tons
302	Input of BSCI* Weight Group 102, tons
...	
400	Input of BSCI* Weight Group 200, tons
401	Input of BSCI* Weight Group 201, tons
...	
900	Input of BSCI* Weight Group 700, tons
...	
903	Input of BSCI* Weight Group 703, tons
904	Input of BSCI* Weight Group 704, tons
...	
1000	Input of BSCI* Weight Group 800*, tons
....	
1099	Input of BSCI* Weight Group 899*, tons

NUMBER = BSCI WT GRP + 200

*Modification to 1965 BSCI weight listing found in Appendix C.

TABLE 15

VCG SPECIFICATIONS

<u>Number</u>	<u>Definition</u>
1100	Input of VCG for BSCI* Weight Group 100, feet
1101	Input of VCG for BSCI* Weight Group 101, feet
1102	Input of VCG for BSCI* Weight Group 102, feet
....	
1200	Input of VCG for BSCI* Weight Group 200, feet
1201	Input of VCG for BSCI* Weight Group 201, feet
....	
1700	Input of VCG for BSCI* Weight Group 700, feet
....	
1703	Input of VCG for BSCI* Weight Group 703, feet
1704	Input of VCG for BSCI* Weight Group 704, feet
....	
1800	Input of VCG for BSCI* Weight Group 800*, feet
....	
1899	Input of VCG for BSCI* Weight Group 899*, feet

NUMBER = BSCI WT GRP + 1000

*Modification to 1965 BSCI weight listing found in Appendix C.

TABLE 16
VOLUME SPECIFICATIONS

<u>Number</u>	<u>Definition</u>
1900	Functional volume group 100**, cubic feet
....	
1911	Functional volume group 111, cubic feet
....	
2000	Functional volume group 200, cubic feet
....	
2100	Functional volume group 300, cubic feet
....	
2199	Functional volume group 399, cubic feet

NUMBER = FUNCTIONAL VOL GRP + 1800

**Functional Classification System defined in Appendix C.

TABLE 17
ELECTRIC LOAD SPECIFICATIONS

<u>Number</u>	<u>Definition</u>
2200	Electric cruise load group 100, KW
2201	Electric cruise load group 200, KW
....	
2208	Electric cruise load group 900, KW
2209	Electric cruise load margin, KW
2210	Electric cruise load total, KW
2211	Electric battle load group 100, KW
2212	Electric battle load group 200, KW
....	
2219	Electric battle load group 900, KW
2220	Electric battle load margin, KW
2221	Electric battle load total, KW
2222	Electric 24 hour average load group 100, KW
2223	Electric 24 hour average load group 200, KW
....	
2230	Electric 24 hour average load group 900, KW
2231	Electric 24 hour average load margin, KW
2232	Electric 24 hour average load total, KW

TABLE 18

MISCELLANEOUS SPECIFICATIONS

<u>Number</u>	<u>Definition</u>
2250	Multiplier for calculated value of volume group 211
2251	Multiplier for calculated value of volume group 212
2252	Multiplier for calculated value of volume group 213
2253	Multiplier for calculated value of volume group 214
2254	Multiplier for calculated value of volume group 215
2255	Multiplier for calculated value of volume group 216
2256	Multiplier for calculated value of volume group 217
2257	Multiplier for calculated value of volume group 218
2258	Multiplier for calculated value of volume group 219
2259	Multiplier for calculated value of volume group 221
2260	Multiplier for calculated value of volume group 222
2261	Multiplier for calculated value of volume group 223
2262	Multiplier for calculated value of volume group 224
2263	Multiplier for calculated value of volume group 225
2264	Multiplier for calculated value of volume group 231
2265	Multiplier for calculated value of volume group 232
2266	Multiplier for calculated value of volume group 233
2267	Multiplier for calculated value of volume group 311
2268	Multiplier for calculated value of volume group 313
2269	Multiplier for calculated value of volume group 325
2270	Multiplier for calculated value of volume group 341
2271	Multiplier for calculated value of volume group 342
2272	Multiplier for calculated value of volume group 343
2273	Multiplier for calculated value of volume group 370
2274	Input for value to be used for deck height, feet
2275	
thru	Not used
2298	
2299	Input for value of machinery box prismatic coefficient

TABLE 19

SPECIAL PAYLOAD SPECIFICATIONS

<u>Number</u>	<u>Definition</u>
2300	BSCI weight group of first special payload item
2301	Functional volume group of first special payload item
2302	Weight of first special payload item, tons
2303	Center of gravity location (feet/factor)* first item
2304	Center of gravity reference index* first item
2305	Deck area inside superstructure for first item (sq.ft.)
2306	Deck area inside hull for first item (sq.ft.)
2307	Not used
2308	Not used
2309	Not used
....	
....	
....	
2490	BSCI weight group of twentieth special payload item
2491	Functional volume group of twentieth special payload item
2492	Weight of twentieth special payload item, tons
2493	Center of gravity location (feet/factor)* twentieth item
2494	Center of gravity reference index* twentieth item
2495	Deck area inside superstructure for twentieth item (sq.ft.)
2496	Deck area inside hull for twentieth item (sq.ft.)
2497	Not used
2498	Not used
2499	Not used
2500	Not used

- *1 = item location relative to strength deck (feet)
- 2 = item location relative to keel (feet)
- 3 = item location as fraction of ship depth at station 10

TABLE 20

EXAMPLE COEFFICIENTS FOR MISCELLANEOUS SPECIFICATIONS
(Personnel Related Items)

<u>Element Number</u>	SHIP		
	<u>DD 931*</u>	<u>Model Standard</u>	<u>FFG 7*</u>
2250	.71	1.0	1.32
2251	.77	1.0	1.17
2252	.63	1.0	.77
2253	.68	1.0	1.11
2254	.57	1.0	.94
2255	.57	1.0	.93
2256	.92	1.0	.99
2257	.74	1.0	1.42
2258	.82	1.0	1.18
2259	.55	1.0	1.33
2260	.61	1.0	1.12
2261	.34	1.0	2.23
2262	.34	1.0	1.72
2263	.24	1.0	3.30
2264	1.01	1.0	.96
2265	.24	1.0	1.72
2266	.60	1.0	2.82
2267	.66	1.0	1.03
2268	.77	1.0	2.69
2269	.75	1.0	1.65
2270	.85	1.0	1.33
2271	.98	1.0	1.73
2272	1.19	1.0	.62
2273	1.04	1.0	1.10

*DD 931 and FFG 7 were selected to indicate the recommended range for coefficients, since DD 931 was launched in 1955 and FFG 7 is scheduled for launch in 1977.

TABLE 21

PAYLOAD SHOPPING LIST

<u>ITEM</u>	<u>DEFINITION</u>	<u>ITEM</u>	<u>DEFINITION</u>
<u>Radio Communications</u>			
1	FF(Non ASW Command and Cont)	28	SPS 48A (MTI)
2	FF(ASW Command and Control)	29	SPS 58
3	DDG	30	SPN 6
4	Baseline Strike Cruiser	31	SPN 10
5	CG/CGN	32	SPN 12
6	Blank	33	SPN 35
		34	SPN 42
		35	Beacon Video Processor
		36	SPH 2 (RAVIR MOD 3)
		37	SPS 58C
		38	Blank
		39	Blank
<u>Radars</u>			
7	Target Acquisition System Mod 0		
8	Target Acquisition System Mod 3		
9	SPS 10		
10	SPS 10 W/IFF		
11	SPS 26	40	SQS 53
12	SPS 29	41	SQS 56
13	SPS 30	42	SQS 23 (TRAM)
14	SPS 37	43	SQQ 23
15	SPS 39A	44	SQS 26 (CX)
16	SPS 40	45	EDD 610E
17	SPS 40 W/IFF	46	SQA 13 (VDS)
18	SPS 40A W/IFF	47	SQS 35 (IVDS)
19	SPS 43	48	UQN 4
20	SPS 43 W/IFF	49	SQS 23
21	SPS 48 (V)	50	TACTLASS
22	SPS 48C	51	Escort Towed Array System (ETAS)
23	SPS 49	52	SQS 38 (keel)
24	SPS 49 W/IFF	53	505 Sonar
25	SPS 52B	54	Blank
26	SPS 53	55	Blank
27	SPS 55 W/IFF		
		<u>Sonars</u>	

TABLE 21 (continued)

<u>ITEM</u>	<u>DEFINITION</u>	<u>ITEM</u>	<u>DEFINITION</u>
<u>Sonar Domes</u>			
56	23 Keel Dome (Double, Rubber)	78	NTDS - 3C, 15 - 18D
57	23 Bow Dome	79	NTDS - 3C, 15D - CG
58	26.53 Bow Dome	80	NTDS - 3C, 15D - CGN
59	610E/505 Bow Dome	81	SSCDS - 1C
60	23 Keel Dome	82	Conv C and C - CG, CGN
61	610E/505 Keel Dome	83	Blank
62	23 Keel Dome (Rubber)		
63	Blank		
<u>Sonar Liquid</u>			
64	Sonar Liquid (1 ton)		
<u>Electronic Countermeasures (ECM)</u>			
65	FF/FFG Basic	84	3/50 SM, MK-34 w/Shield Mn DK
66	DD/DDG/CG/CGN Basic	85	3/50 SM, MK-34 w/Shield O1 LV
67	SLQ 17	86	3/50 SM, MK-34 w/o Shield O1 LV
68	ALR 59	87	3/50 TM, MK-33 w/ Shield Mn DK
69	WLR-8	88	3/50 TM, MK-33 w/Shield O1 LV
70	SLR-10 or BRD-4, SLR-11	89	3/50 TM, MK-33 w/o Shield Mn DK
71	DTP Suite Three	90	3/50 TM, MK-33 w/o Shield O1 LV
72	Blank	91	5/38 SM, MK-30 Mn DK
<u>Electronic Tactical Data Systems</u>			
73	Conc C and C-FF	92	5/38 SM, MK-30 O1 LV
74	Conv C and C-DD	93	5/54 SM, MK-42 Mn DK
75	ASW C and C-FF-2C, 7D	94	5/54 SM, MK-42 O1 LV
76	NTDS - 4C, 13D - DG/DGN	95	5/54 SM, LW, MK-45/O Mn DK
77	NTDS - 2C, 9D - DDG	96	5/54 SM, LW, MK-45/O O1 LV
		97	8/55 SM, MK -71 Mod O Mn DK
		98	8/55 SM, MK-71 Mod O O1 LV
		99	50 Cal MG O2 LV
		100	Vulcan/Phalanx O1 LV
		101	35 mm twin O1 LV
		102	76 mm single O1 LV
		103	76 mm single Mn DK
		104	Blank
		105	Blank
<u>Guns and Ammo Handling and Stowage</u>			

TABLE 21 (continued)

<u>ITEM</u>	<u>DEFINITION</u>	<u>ITEM</u>	<u>DEFINITION</u>
<u>Gun Fire Control Systems</u>			
106	MK-86 (CSG)	132	Tartar, MK-22
107	MK-37	133	Tartar, MK-11
108	MK-56	134	BPDMS, MK-25
109	MK-63/26	135	GMLS, MK-26 (MOD 0)
110	MK-68/6	136	GMLS, MK-26 (MOD 1)
111	GFCs for 5"/54 w/AEGIS ILL.	137	GMLS, MK-26 (MOD 2)
112	MK-86 (LFS) Mod 3	138	5" SSR, MK-105
113	MK-86 (LFS) Mod 4	139	CHAFFROC, 4 Launch
114	MK-86 with AAW and CWI MOD 5	140	Harpoon Launcher (MK-13)
115	MK-87	141	Harpoon (Box) w/4 Missiles
116	MK-92 CWI/STIR	142	IPMDS Launcher
117	MK-86 - 5 w/o SPQ 9	143	Redeye
118	Blank	144	Sea Launched Cruise Missile (SLCM) w/4 missiles
<u>Gun Ammo</u>			
119	3"/50 Rd.	145	Near Term Laser Pointer Trainer
120	5"/38 Rd.	146	Tarpon Canister Launcher w/4 missiles
121	5"/54 Rd.	147	Blank
122	8"/55 Rd.	<u>ASW Rocket and Missile Launchers</u>	
123	40 mm	148	ASROC-8, MK-16/4 w/8 ASROC, O1 Level
124	20 mm	149	ASROC-8, MK-16/4 w/8 ASROC, o2 Level
125	Blank	150	ASROC Reload, Mag & Handling Gear
126	Blank	151	DASH Launch (Hangar)
		152	Blank
<u>Rocket and Missile Launchers</u>			
127	NATO Sea Sparrow, MK-2910 (8 boxes)	<u>Missile Fire Control Systems</u>	
128	Terr-40, MK-10/3-6	153	Near Term Laser System less Pointer Trainer
129	Terr-60, MK-10/7-8 Mn DK	154	Sea Launched Cruise Missile FCS
130	Terr-60, MK-10/7-8 O1 LV	155	Weapons Direction System MK-13
131	Tartar, MK-13	156	MK-74 FCS (1 DIR) (Tartar C)
		157	MK-74 FCS (2 DIR)

TABLE 21 (continued)

<u>ITEM</u>	<u>DEFINITION</u>	<u>ITEM</u>	<u>DEFINITION</u>
158	MK-115 BPDMS FCS		
159	CHAFFROC FCS		
160	MK-91 GMFCS (1 Chan)		
161	MK-91 GMFCS (2 Chan)		
162	MK-7/1 Aegis (2 Slaved)		
163	MK-7/1 Aegis (2 Slaved, 1 Track)		
164	MK-7/1 Aegis (3 Slaved, 1 Track)		
165	Harpoon FCS		
166	Blank		
<u>Missile & Rocket Ammo</u>			
167	RIM 67A-Ter 3 DK		
168	RIM 66A-Tartar 2 DK		
169	RIM 67A-Ter 2 DK		
170	RIM 66A-Tartar MN DK		
171	RIM 7H Sparrow		
172	5" Rocket, MK-10		
173	CHAFFROC		
174	Harpoon		
175	Blank		
<u>Torpedo Tubes, Handling & Stowage</u>			
176	MK-25 TT 2 DK		
177	MK-25 TT 01 LV		
178	MK-32 Twin Mn DK		
179	MK-32 Twin 01 LV		
180	MK-32 Triple		
181	Torpedo Countermeasure Launchers		
182	Hedgehog		
183	Blank		
<u>ASW and Torpedo Fire Control Systems</u>			
184	MK-114 UBFCFS		
185	MK-114/12 UBFCFS		
186	MK-116 UBFCFS		
187	Drone Control SRW4C w/URW 15		
188	Drone Control SRW4C		
189	TORP FCS (MK-25) (Hull)		
190	TORP FCS (MK-25) (Supstr)		
191	Tarpon FCS Interface Alterations		
192	Blank		
<u>ASW Ammo</u>			
193	ASROC Reload (02 Level)		
194	ASROC Reload (01 Level)		
195	MK-37/0,3 2 DK		
196	MK-37/0,3 01 LV		
197	MK-37/1,2 2 DK		
198	MK-44 Mn DK		
199	MK-44 01 LV		
200	MK-46 MndK		
201	MK-48 Mn DK		
202	MK-48 2 DK		
203	Blank		
<u>Helos</u>			
204	Two LAMPS III (main deck)		
205	HASP-T Helo (main deck)		
206	Blank		
207	Blank		

TABLE 21 (continued)

<u>ITEM</u>	<u>DEFINITION</u>	<u>ITEM</u>	<u>DEFINITION</u>
<u>Helo Support</u>			
208	LAMPS MK III Package	230	Sewage Treatment Plant (175 man)
209	LAMPS Control	231	Blank
210	LAUV 1	<u>Replenishment at Sea & Cargo Handling</u>	
211	LAUV 2	232	FAST System - Dest/Cruiser
212	LAMPS (Platform & Refuel)	233	Blank
213	One LAMPS III Hangar	<u>Liquids</u>	
214	Helo Tie-Down	234	NSFO (100 gal.)
215	Aero Stores (1000 ft ³)	235	Diesel Oil (100 gal.)
216	Blank	236	Potable Water (100 gal.)
<u>Aviation Liquids</u>			
217	JP 5 (100 gal.)	237	Liquid O ₂ (100 gallons)
218	Av Gas (100 gal.)	238	Auto Gas (100 gal.)
219	Av Lube Oil (100 gal.)	239	Blank
220	Blank	<u>Boats</u>	
<u>Small Arms</u>			
221	Misc. - FF/FFG	240	14' Punt
222	Misc. - DD/DDG/CG	241	26' Motor Whale Board (Wherry)
223	Misc. - Cruiser	242	26' Personnel
224	Misc. - (Marine Detach.)	243	28' Personnel
225	Misc. - Small Ships	244	33' Utility
<u>Aviation Ammo</u>			
226	MK-46 Torp	245	33' Personnel
227	Blank	246	35' Motor Boat
228	Blank	247	40' Utility
229	Blank	248	40' Personnel
		249	50' Motor Launch
		250	50' Utility
		251	Blank

TABLE 21 (continued)

<u>ITEM</u>	<u>DEFINITION</u>
	<u>Future Development</u>
252	Weight Margin (1 ton)
	<u>Undefined Items</u>
253	Blank
thru	
300	

APPENDIX B

SAMPLE OUTPUT

APPENDIX B

SAMPLE OUTPUT

A sample output is provided in this appendix. The output printed consists of the ship specifications, special payload input, payload specifications, summary of results, functional grouping results, BSCI weight listing, and functional electric loads.

The first items printed in the output are the ship specifications. The 75 ship specifications are printed in three columns of 25 each. Column 1 gives the specifications of items 1 through 25 of Table 12. Items 26 through 50 of Table 12 are presented in column 2 and items 51 through 75 are found in column 3.

The special payload input is printed in the format specified in Appendix A.

The payload specifications are printed next. The item number of each payload item selected from the shopping list is printed with the quantity of the item.

The summary of results gives the overall ship characteristics for the ship run plus a listing of some selected ratios. The nomenclature used for most of the items in the summary of results are found in Appendix F. For those items not found in Appendix F, the following definitions are provided:

LEN R DK	Length of raised deck added, ft.
VCG FLD	Full load ship center of gravity, ft.
SUS SHP	SHP at maximum sustained speed
END SHP	SHP at endurance speed
AVSEASPD	Average sea speed in North Atlantic Ocean, knots
NU ACCOM	Total number of accommodations on ship

FLD DENS	Ship density at full load, lbs./cu.ft.
LSP DENS	Ship density at light ship, lbs./cu.ft.
WPAY/FLD	Payload weight fraction
WPER/FLD	Personnel weight fraction
WOPS/FLD	Ship operations weight fraction
VPAY/VOL	Payload volume fraction
VPER/VOL	Personnel volume fraction
VOPS/VOL	Ship operations volume fraction
WTG2/SHP	Ratio of weight group 2 to SHP, lbs./SHP
VMB/SHP	Ratio of machinery box volume to SHP, cu.ft./SHP
WT3/KWIN	Ratio of weight group 3 to installed KW, tons/KW
WTG1/VOL	Ratio of weight group 1 to total volume, lbs./cu.ft.
WTG5/VOL	Ratio of weight group 5 to total volume, lbs./cu.ft.
VHAB/MAN	Ratio of volume of personnel living and support to total accommodations, cu.ft./man
WHAB/MAN	Ratio of weight of personnel living and support to total accommodations, lbs./man
MEN/DISP	Ratio total accommodations to full load displacement, men/ton
KWIN/FLD	Ratio of installed KW to full load displacement, KW/ton
SHP/DISP	Ratio of SHP to full load displacement, SHP/ton
DP*V/SHP	Ratio of full load displacement times VSUS to SHP (transport efficiency), dimensionless
WPY*V/DP	Ratio of payload weight times VSUS to full load displacement, knots

The ship constants as defined in Table 18 are presented next. These are followed by the detailed results for the functional groupings of Appendix C, Table 22.

Results for the BSCI weight listing as given in Table 23 of Appendix C follow the functional grouping results. The last results printed are the functional electric loads as described in Section 3.9.

SHIP NUMBER 2

SHIP SPECIFICATIONS

VSUS	0.00	DELTA CP	5.00	CPO ACC	15.00
VEND	20.00		0.00	CREW ACC	156.00
RANGE	4500.00		0.00	FLAG ACC	0.00
LBP	408.00		0.00	TRP ACC	0.00
L/B	9.07		0.00	PASS ACC	0.00
B/H	3.14	SSEL TYP	5.00	DAYS DUR	45.00
CP	0.59	EMEL TYP	4.00		0.00
CX	0.75	NU LOWSD	0.00		0.00
	0.00	NU MEDSD	4.00		0.00
	0.00	NU HI SD	0.00		0.00
PROP PLT	6.00	NU GT GN	0.00	HULL MAT	1.00
SUS SHP	40000.00	NU ST GN	0.00	SUPSTMAT	2.00
NU BOILS	0.00	KW/DIESL	1000.00		0.00
NU REACT	0.00	KW/GAS 1	0.00	GM/B MIN	0.08
NU ENGS	2.00	KW/STM 3	0.00		0.00
NU SHAFT	1.00	ELC MARG	0.30	DISP TOL	10.00
PROPELLR	2.00		0.00	MXDIS IT	20.00
SHPT TYP	1.00		0.00	VCG TOL	0.10
PROP RPM	0.00		0.00	MXVCG IT	20.00
PROP DIA	0.00	HEAT TYP	2.00	DCWTMARG	0.05
DEPTH MB	0.00	FIN STAB	2.00	FS CORR	0.00
LENTH MB	0.00		0.00	PRNT TYP	2.00
BEAM MB	0.00		0.00	PRNTCNST	1.00
PC END	0.00		0.00		0.00
PC MAXSP	0.00	OFF ACC	14.00	PASSAGE	2.00
PROP PLT	GASTURB2	SHPT TYP	HOLLOW	HULL MAT	STEEL
SSEL TYP	MEDSPDIE	PROPELLR	CONT PIT	SUPSTMAT	ALUMINUM
EMEL TYP	MEDSPDIE	FIN STAB	YES	PASSAGE	PORTSTBD
		HEAT TYP	ELECTRIC		

SPECIAL PAYLOAD INPUT

WT GRP	VOL GRP	WT	VCG NU	VCG REF	AREA SUP	AREA HULL
NO SPECIAL PAYLOAD INPUT						

SHIP NUMBER 2

PAYLOAD SPECIFICATIONS

QNTY	ITEM	QNTY	ITEM	QNTY	ITEM	QNTY	ITEM	QNTY	ITEM
1.00	2	1.00	204						
1.00	24	1.00	208						
1.00	27	1.00	209						
1.00	41	2.00	214						
1.00	61	4.00	215						
8.00	64	1.00	221						
1.00	65	12.00	226						
1.00	75	1.00	230						
1.00	100	1.00	232						
1.00	102	1.00	190						
1.00	116	1.00	242						
800.00	119	193.00	217						
10000.00	124	10.00	219						
1.00	131	1.00	48						
40.00	168								
2.00	180								
1.00	165								
1.00	212								
2.00	213								
6.00	200								

SUMMARY OF RESULTS

LBP	408.00	DISP PLD	3547.97	PLD DENS	16.12
BEAM	42.42	DISP LSP	2459.70	LSP DENS	11.18
DRAFT	15.96	VR LOADS	965.29	WPAY/PLD	0.10
D 0	33.89	WT MARG	122.98	WPER/PLD	0.04
D 10	25.50	WTGRP 1	1185.68	WOPS/PLD	0.43
D 20	26.71	WTGRP 2	270.56	VPAY/VOL	0.18
D AVG	35.15	WTGRP 3	166.51	VPER/VOL	0.23
LEN R DK	386.62	WTGRP 4	131.29	VOPS/VOL	0.59
CP	0.59	WTGRP 5	345.38	WTG2/SHP	15.15
CK	0.75	WTGRP 6	260.44	VMB/SHP	2.40
VCG PLD	18.39	WTGRP 7	99.84	WT3/KWIN	93.25
VCG/DAVG	0.68	VOL TOT	493040.00	WTG1/VOL	5.39
L/B	9.62	VOL HULL	382334.80	WTG5/VOL	1.57
B/H	2.66	VOL SSIR	110705.10	VHAB/MAN	517.45
EXCES KG	0.00	CRUISEKW	2201.26	WHAB/MAN	802.77
RANGE	4500.00	BATTLEKW	1739.11	MEN/DISP	0.05
SUS SHP	40000.00	24 HR KW	1286.52	KWIN/PLD	1.13
END SHP	7341.77	NU LOWSD	0.00	SHP/DISP	11.27
VSUS	30.49	NU MEDSD	4.00	DP*V/SHP	18.61
VEND	20.00	NU HI SD	0.00	WPY*V/DP	2.96
AVSEASPD	27.72	NU GT GN	0.00		
NU ACCOM	185.00	NU ST GN	0.00		
KW INST	4000.00	KW/DIESL	1000.00		
KW SPER	4000.00	KW/GAS T	0.00		
KW EMERG	0.00	KW/STM G	0.00		

SHIP NUMBER 2
SHIP CONSTANTS

ELEMENT NUMBER	VALUE
2250	1.32
2251	1.17
2252	0.77
2253	1.11
2254	0.94
2255	0.93
2256	0.99
2257	1.42
2258	1.18
2259	1.33
2260	1.12
2261	2.23
2262	1.72
2263	3.30
2264	0.96
2265	1.72
2266	2.82
2267	1.03
2268	2.69
2269	1.65
2270	1.33
2271	1.73
2272	0.62
2273	1.10
2274	8.50
2275	0.00
2276	0.00
2277	0.00
2278	0.00
2279	0.00
2280	0.00
2281	0.00
2282	0.00
2283	0.00
2284	0.00
2285	0.00
2286	0.00
2287	0.00
2288	0.00
2289	0.00
2290	0.00
2291	0.00
2292	0.00
2293	0.00
2294	0.00
2295	0.00
2296	0.00
2297	0.00
2298	0.00
2299	0.00

SHIP NUMBER 2

DETAILED RESULTS--FUNCTIONAL GROUPING

GROUP	NAME	WEIGHT TONS	WT FRAC	VOLUME CU FT	VOL FRAC	DENSITY LBS/CU FT
100	MIL MISS	345.0	0.0973	89288.	0.1811	8.66
110	COMM/DET	70.0	0.0197	27391.	0.0556	5.72
111	RADIOCOM	16.1	0.0045	7446.	0.0151	4.84
112	RADAR	7.9	0.0022	1615.	0.0033	10.96
113	SONAR	9.3	0.0026	2015.	0.0041	10.34
114	ECH	4.5	0.0013	2295.	0.0047	4.39
115	EVALUATE	19.6	0.0055	11407.	0.0231	3.85
116	C/D SUPP	12.6	0.0035	2614.	0.0053	10.78
120	WEAPONS	163.7	0.0462	18581.	0.0377	19.73
121	GUNS	42.6	0.0120	6208.	0.0126	15.37
122	MISSILES	90.2	0.0254	8534.	0.0173	23.68
123	ASW	9.6	0.0027	935.	0.0019	23.09
124	MINE WAR	0.0	0.0000	0.	0.0000	0.00
125	SM ARMS	3.0	0.0008	765.	0.0016	8.78
126	CM NO EL	11.9	0.0034	0.	0.0000	0.00
127	WEAP SUP	6.3	0.0018	2139.	0.0043	6.64
128	SPECWEAP	0.0	0.0000	0.	0.0000	0.00
130	AVIATION	111.3	0.0314	43316.	0.0879	5.76
131	CONTROL	12.1	0.0034	2763.	0.0056	9.84
132	STOW/MNT	21.9	0.0062	34850.	0.0707	1.41
133	STORES	6.7	0.0019	3400.	0.0069	4.40
134	LIQUIDS	68.0	0.0192	2304.	0.0047	66.08
135	ORDNANCE	2.7	0.0008	0.	0.0000	0.00
140	AMPH OPS	0.0	0.0000	0.	0.0000	0.00
150	CARGO	0.0	0.0000	0.	0.0000	0.00
160	FLAG	0.0	0.0000	0.	0.0000	0.00
170	PASSNGER	0.0	0.0000	0.	0.0000	0.00
180	SPEC MIS	0.0	0.0000	0.	0.0000	0.00
200	PERSONEL	140.8	0.0397	111150.	0.2254	2.84
210	LIVING	38.3	0.0108	68265.	0.1385	1.26
211	OFF BER	0.0	0.0000	9217.	0.0187	0.00
212	OFF MESS	0.0	0.0000	3456.	0.0070	0.00
213	OFF BATH	0.0	0.0000	1034.	0.0021	0.00
214	CPO BER	0.0	0.0000	4790.	0.0097	0.00
215	CPO MESS	0.0	0.0000	1817.	0.0037	0.00
216	CPO BATH	0.0	0.0000	1297.	0.0026	0.00
217	CREW BER	0.0	0.0000	29722.	0.0603	0.00
218	CREWMESS	0.0	0.0000	11412.	0.0231	0.00
219	CREWBATH	0.0	0.0000	5520.	0.0112	0.00

SHIP NUMBER 2

DETAILED RESULTS--FUNCTIONAL GROUPING CONTINUED

GROUP	NAME	WEIGHT TONS	WT FRAC	VOLUME CU FT	VOL FRAC	DENSITY LBS/CU FT
220	SUPPORT	28.0	0.0079	27462.	0.0557	2.28
221	ADMIN FN	1.1	0.0003	1297.	0.0026	1.90
222	FOOD P&H	10.2	0.0029	7552.	0.0153	3.02
223	MED & DEN	1.3	0.0004	2824.	0.0057	1.05
224	PER SERV	8.2	0.0023	7450.	0.0151	2.47
225	REC & WEL	2.1	0.0006	6639.	0.0135	0.72
226	SEWAGE	5.0	0.0014	1700.	0.0034	6.59
230	STOWAGE	74.5	0.0210	15423.	0.0313	10.82
231	STORES	30.3	0.0085	5036.	0.0102	13.49
232	PER STOW	14.2	0.0040	4408.	0.0089	7.23
233	POTWATER	30.0	0.0084	5979.	0.0121	11.23
300	SHIP OPS	1509.4	0.4256	292602.	0.5935	11.56
310	CONTROL	36.3	0.0102	18529.	0.0376	4.39
311	SHIP CNT	27.9	0.0079	6056.	0.0123	10.31
312	DAM CONT	0.0	0.0000	2541.	0.0052	0.00
313	OFFICES	8.4	0.0024	9932.	0.0201	1.90
320	MACH SYS	557.3	0.1571	130318.	0.2643	9.58
321	MACH BOX	393.1	0.1108	96170.	0.1951	9.16
322	UPTAKES	12.7	0.0036	20190.	0.0409	1.41
323	SH, BR, PR	87.0	0.0245	0.	0.0000	0.00
324	MANEUVER	32.1	0.0091	4226.	0.0086	17.03
325	VENTILAT	32.4	0.0091	9732.	0.0197	7.45
330	DECK AUX	61.2	0.0172	15085.	0.0306	9.08
331	ANCH, M&T	39.8	0.0112	15000.	0.0304	5.94
332	UNREP	21.4	0.0060	85.	0.0002	563.95
340	MAINTAIN	46.1	0.0130	5938.	0.0120	17.41
341	MECHANIC	5.5	0.0016	3522.	0.0071	3.50
342	ELECTRIC	2.8	0.0008	1765.	0.0036	3.50
343	MISC	37.9	0.0107	651.	0.0013	130.26
350	STOWAGE	799.7	0.2255	39059.	0.0792	45.86
351	FUEL OIL	641.6	0.1809	26293.	0.0533	54.66
352	R FEED W	0.0	0.0000	0.	0.0000	0.00
353	LUBE OIL	14.3	0.0040	559.	0.0011	57.44
354	DIES OIL	83.7	0.0236	3327.	0.0067	56.33
355	MISC LIQ	0.0	0.0000	0.	0.0000	0.00
356	STORE&SUP	43.4	0.0122	8879.	0.0180	10.94
357	BOATS	16.7	0.0047	0.	0.0000	0.00

SHIP NUMBER 2

DETAILED RESULTS--FUNCTIONAL GROUPING CONTINUED

GROUP	NAME	WEIGHT TONS	WT FRAC	VOLUME CU FT	VOL FRAC	DENSITY LBS/CU FT
360	TANKAGE	0.0	0.0000	23449.	0.0476	0.00
361	BALLAST	0.0	0.0000	9000.	0.0183	0.00
362	PEAK	0.0	0.0000	1449.	0.0029	0.00
363	VOIDS	0.0	0.0000	13000.	0.0264	0.00
364	XFLOODNG	0.0	0.0000	0.	0.0000	0.00
365	MISC TNK	0.0	0.0000	0.	0.0000	0.00
370	PASS&ACC	8.9	0.0025	60225.	0.1222	0.33
380	HULL MAR	0.0	0.0000	0.	0.0000	0.00
390	SUP MARG	0.0	0.0000	0.	0.0000	0.00
400	HULL GRP	1207.3	0.3404			
410	BASCHULL	532.8	0.1502			
420	SEC HULL	552.9	0.1559			
430	DECKHOUS	121.6	0.0343			
440	ARMOR	0.0	0.0000			
450	FREEPLLQ	0.0	0.0000			
500	SHIP SYS	344.3	0.0971			
	TOTAL	3546.8	1.0000	493041.	1.0000	16.11

SHIP NUMBER 2

DETAILED RESULTS--BSCI WEIGHT LISTING

GROUP	NAME	WEIGHT TONS	WT FRAC FULL LD	WT FRAC LITE SH	VCG FT
100	PLATING	265.2	0.0747	0.1078	13.9
101	FRAMING	155.9	0.0439	0.0634	11.7
102	INN BOTM	0.0	0.0000	0.0000	4.8
103	PLATFLAT	75.5	0.0213	0.0307	13.8
104		0.0	0.0000	0.0000	0.0
105		0.0	0.0000	0.0000	0.0
106		0.0	0.0000	0.0000	0.0
107	ALL DECK	183.5	0.0517	0.0746	31.7
108		0.0	0.0000	0.0000	0.0
109		0.0	0.0000	0.0000	0.0
110		0.0	0.0000	0.0000	0.0
111	SUPERSTR	121.6	0.0343	0.0494	46.4
112	PROP FND	41.9	0.0118	0.0170	9.2
113	AUX FNDS	83.3	0.0235	0.0339	14.1
114	STR BKHD	131.8	0.0371	0.0536	18.6
115	TRK&ENCL	36.7	0.0103	0.0149	21.0
116	STR SPON	0.0	0.0000	0.0000	0.0
117	ARMOR	0.0	0.0000	0.0000	0.0
118	AC T STR	0.0	0.0000	0.0000	15.4
119	CAST&FOR	35.8	0.0101	0.0146	13.2
120	SEACHEST	1.8	0.0005	0.0007	5.2
121	BAL UNIT	0.0	0.0000	0.0000	0.0
122	SPEC DRS	0.0	0.0000	0.0000	24.8
123	DRS&HTCH	17.0	0.0048	0.0069	29.8
124		0.0	0.0000	0.0000	0.0
125	MASTKGPT	4.6	0.0013	0.0019	84.3
127	SONAR DM	2.5	0.0007	0.0010	-2.0
128	TOWRPLAT	0.0	0.0000	0.0000	0.0
150	WELDRIVT	28.5	0.0080	0.0116	20.5
151	FREEFLIQ	0.0	0.0000	0.0000	5.6
	GRP1 TOT	1185.7	0.3342	0.4820	20.9
200	BOIL&CON	0.0	0.0000	0.0000	15.3
201	PROPUNIT	111.5	0.0314	0.0453	14.0
202	MN CONDS	0.0	0.0000	0.0000	9.3
203	SH, BR, PR	87.0	0.0245	0.0354	5.0
204	COMB AIR	7.8	0.0022	0.0032	38.4
205	UPTAKES	12.7	0.0036	0.0052	58.9
206	PROP CNT	6.0	0.0017	0.0024	21.1
207	MN STM S	0.0	0.0000	0.0000	22.5
208	FW&CONDN	0.0	0.0000	0.0000	14.2
209	CIRC&CWS	3.6	0.0010	0.0014	8.8
210	FOSERSYS	8.9	0.0025	0.0036	10.9
211	LBOILSYS	11.0	0.0031	0.0045	10.9
250	REPAIRPT	5.0	0.0014	0.0020	16.5
251	OPER FLD	17.0	0.0048	0.0069	11.2
	GRP2 TOT	270.6	0.0763	0.1100	13.6

SHIP NUMBER 2

DETAILED RESULTS--BSCI WEIGHT LISTING CONTINUED

GROUP	NAME	WEIGHT TONS	WT FRAC FULL LD	WT FRAC LITE SH	VCG FT
300	EL PWGEN	96.2	0.0271	0.0391	16.7
301	POW SWBD	14.6	0.0041	0.0059	21.0
302	CABLE	35.0	0.0099	0.0142	25.6
303	LIGHTING	17.4	0.0049	0.0071	30.3
350	REPAIRPT	3.4	0.0009	0.0014	17.0
351	GEN FLDS	0.0	0.0000	0.0000	13.5
	GRP3 TOT	166.5	0.0469	0.0677	20.4
400	NAV EQUIP	3.7	0.0011	0.0015	51.4
401	IC SYSTS	22.1	0.0062	0.0090	27.7
402	GFC SYST	10.0	0.0028	0.0041	49.0
403	CM NO EL	11.9	0.0034	0.0048	24.3
404	ECM	4.5	0.0013	0.0018	49.5
405	MFC SYS	0.4	0.0001	0.0002	64.0
406	ASW FCS	11.1	0.0031	0.0045	52.6
407	TORP FCS	0.0	0.0000	0.0000	0.0
408	RADAR	7.9	0.0022	0.0032	49.5
409	RADIOCOM	16.1	0.0045	0.0065	28.5
410	ELEC NAV	2.0	0.0006	0.0008	55.0
411	SPACTRCK	0.0	0.0000	0.0000	0.0
412	SONAR	9.3	0.0026	0.0038	17.5
413	ELEC TDS	19.6	0.0055	0.0080	43.0
415	ELECTEST	0.0	0.0000	0.0000	0.0
450	REPAIRPT	4.6	0.0013	0.0019	28.9
451	CC OPFLD	8.0	0.0023	0.0033	-3.0
	GRP4 TOT	131.3	0.0370	0.0534	34.2
500	HEAT SYS	12.7	0.0036	0.0051	13.1
501	VENT SYS	40.5	0.0114	0.0165	33.5
502	AIR COND	22.0	0.0062	0.0090	20.6
503	REFR PL	7.5	0.0021	0.0030	16.4
504	HEAP, ETC	5.6	0.0016	0.0023	21.0
505	PLUMBING	7.4	0.0021	0.0030	27.4
506	FIREMAIN	29.9	0.0084	0.0121	24.8
507	FIRE EXT	8.0	0.0023	0.0033	27.5
508	BALSTSYS	11.4	0.0032	0.0047	10.2
509	FRESHWAT	13.3	0.0038	0.0054	22.9
510	SCUPPERS	2.3	0.0007	0.0009	32.1
511	FUELTRAN	22.2	0.0063	0.0090	13.1
512	TANKHEAT	0.0	0.0000	0.0000	5.9
513	COMP AIR	22.7	0.0064	0.0092	16.4
514	AUX STM	0.0	0.0000	0.0000	12.3
515	BUOY CNT	0.0	0.0000	0.0000	0.0
516	MISPIPE	0.0	0.0000	0.0000	10.5
517	DISTILLG	5.6	0.0016	0.0023	17.6
518	STEERING	11.2	0.0032	0.0046	15.8
519	RUDDERS	20.9	0.0059	0.0085	12.7
520	ANCH, MET	28.0	0.0079	0.0114	25.1

SHIP NUMBER 2

DETAILED RESULTS--BSCI WEIGHT LISTING CONTINUED

GROUP	NAME	WEIGHT TONS	WT FRAC FULL LD	WT FRAC LITE SH	VCG FT
521	STOR EQP	4.9	0.0014	0.0020	37.7
522	ELOGEAR	0.0	0.0000	0.0000	0.0
523	AIR ELEV	0.0	0.0000	0.0000	0.0
524	ACARGEAR	4.0	0.0011	0.0016	34.0
525	CATSEJBD	0.0	0.0000	0.0000	0.0
526	HYDROFLS	0.0	0.0000	0.0000	0.0
527	STAB FIN	24.7	0.0070	0.0100	7.9
528	UNREP	21.4	0.0060	0.0087	34.0
550	REPAIRPT	3.5	0.0010	0.0014	18.1
551	AUX FLDS	15.6	0.0044	0.0064	19.8
	GRP5 TOT	345.4	0.0973	0.1404	21.4
600	HULL FIT	11.8	0.0033	0.0048	38.3
601	BOATS	16.7	0.0047	0.0068	44.0
602	RIG&CANV	1.0	0.0003	0.0004	45.6
603	LADEGRAT	26.6	0.0075	0.0108	17.7
604	NONS B&D	19.3	0.0054	0.0079	32.7
605	PAINTING	35.9	0.0101	0.0146	22.2
606	DK COVER	14.5	0.0041	0.0059	29.7
607	HULL INS	38.0	0.0107	0.0154	29.2
608	STORERMS	32.6	0.0092	0.0133	22.8
609	UTIL EQP	8.2	0.0023	0.0033	26.1
610	WKSP EQP	9.3	0.0026	0.0038	27.5
611	GALY EQP	10.2	0.0029	0.0041	31.4
612	LIV FURN	21.6	0.0061	0.0088	29.1
613	OFF FURN	11.9	0.0033	0.0048	35.3
614	H&D FURN	1.3	0.0004	0.0005	29.5
615	RAD SHLD	0.0	0.0000	0.0000	0.0
650	REPAIRPT	1.7	0.0005	0.0007	24.1
651	O&P FLDS	0.0	0.0000	0.0000	0.0
	GRP6 TOT	260.4	0.0734	0.1059	28.1
700	GUN MNTS	17.5	0.0049	0.0071	44.0
701		0.0	0.0000	0.0000	0.0
702		0.0	0.0000	0.0000	0.0
703	SPWEPH&S	0.0	0.0000	0.0000	0.0
704	MIS LH&S	66.0	0.0186	0.0268	31.0
705		0.0	0.0000	0.0000	0.0
706		0.0	0.0000	0.0000	0.0
707		0.0	0.0000	0.0000	0.0
708	TORPTH&S	7.0	0.0020	0.0028	37.0
709		0.0	0.0000	0.0000	0.0
710	MINE H&S	0.0	0.0000	0.0000	0.0
711	SM ARMS	3.0	0.0008	0.0012	34.0
712	AIR H&ST	0.0	0.0000	0.0000	0.0
713		0.0	0.0000	0.0000	0.0
720	CARGOH&S	0.0	0.0000	0.0000	0.0
750	REPAIRPT	5.6	0.0016	0.0023	20.0
751	ARM FLDS	0.7	0.0002	0.0003	32.7
	GRP7 TOT	99.8	0.0281	0.0406	33.2

SHIP NUMBER 2

DETAILED RESULTS--BSCI WEIGHT LISTING CONTINUED

GROUP	NAME	WEIGHT TONS	WT PRAC FULL LD	VCG FT
800	SHIP OCE	20.7	0.0058	25.5
801	TRPS&EFP	0.0	0.0000	25.5
802	PASSE&EFP	0.0	0.0000	25.5
803	SHIPAMMO	41.4	0.0117	27.9
804	AV AMMO	2.7	0.0008	36.0
805	AIRCRAFT	17.9	0.0050	41.0
806	PROV&PST	30.3	0.0085	17.2
807	GEN STOR	8.1	0.0023	23.2
808	MARINEST	0.0	0.0000	0.0
809	AERO STR	6.7	0.0019	27.2
810	ORDSTRSH	0.0	0.0000	0.0
811	ORDSTRAV	0.0	0.0000	0.0
812	POTWATER	30.0	0.0084	4.2
813	R FEED W	0.0	0.0000	4.7
814	LUBOILSH	14.3	0.0040	16.2
815	LUBOILAV	3.7	0.0010	10.2
816	FUEL OIL	641.6	0.1808	8.3
817	DIES OIL	83.7	0.0236	12.5
818	GASOLINE	0.0	0.0000	0.0
819	JP-5	64.3	0.0181	11.2
820	MISC LIQ	0.0	0.0000	0.0
821	CARGO	0.0	0.0000	0.0
822	BALL WAT	0.0	0.0000	0.0
	VRLOAD TOT	965.3	0.2721	11.3
	LIGHT SHIP	2459.7	0.6933	22.1
	WT MARGIN	123.0	0.0347	22.0
	FULL LOAD DISP	3548.0	1.0000	18.4

DETAILED RESULTS--FUNCTIONAL ELECTRIC LOADS

GROUP	NAME	CRUISE KW	BATTLE KW	24 HR AVG KW
100	PA&STEER	122.3	126.6	131.9
200	AUX MACH	202.5	250.2	169.3
300	DECKMACH	2.0	1.5	0.3
400	SHOPS	6.9	1.2	5.4
500	IC&ELEX	197.9	219.1	184.1
600	ORDN SYS	25.6	102.9	12.1
700	HOTEL	119.3	92.8	139.4
800	A/C&VENT	786.8	328.8	247.7
900	PWR CONV	110.0	214.6	99.4
	ELECMARG	508.0	401.3	296.9
	TOTAL KW	2201.3	1739.1	1286.5

APPENDIX C

CLASSIFICATION SYSTEMS

APPENDIX C

CLASSIFICATION SYSTEMS

The classification systems used to identify functional and weight groups are given in this appendix. Table 22 is the functional classification system developed for the model. Table 23 gives the BSCI weight groups as modified for use in the model.

Although the Ship Work Breakdown Structure (SWBS) described in Reference (20) is the system currently used to classify weight groups for ships in the U. S. Navy, the BSCI classification system was chosen for use in this thesis. There were two reasons for choosing the BSCI system. First, most of the sample ships weight data was in the BSCI format. Secondly, at the three-digit weight breakdown level, SWBS data can be readily converted to BSCI format; however, BSCI data at the same level of detail cannot easily be converted to SWBS format. This is because the SWBS format is in the finer level of detail at the three-digit level.

TABLE 22

FUNCTIONAL CLASSIFICATION SYSTEM

ITEM NUMBER	FUNCTIONAL NAME	U.S. NAVY SHIP SPACE CLASSIFICATION SYSTEM NUMBER (Reference 17)	NAVSHIPS B.S.C.I. WEIGHT Group (1965)*
100	MILITARY MISSION (Payload)	Group 1	
110	COMMUNICATIONS, DETECTION & EVALUATION	1.1	
111	Radio, Signal, Secure Comms, Lookout	1.111, 1.112 1.113, 1.114	409
112	Radar	1.115	408
113	Sonar	1.116	412
114	Electronic Countermeasures	1.117	404
115	Evaluation	1.118	413
116	Comms, Detection, Evaluation Support	1.12	415, 450, 451
120	WEAPONS	1.2	
121	Guns	1.21	402, 700, 873
122	Missiles	1.22	405, 774, 883
123	ASW	1.23, 1.24	486, 784, 708, 893
124	Mines	1.25	710
125	Small arms, pyrotechnics	1.26	711
126	Countermeasures	1.27	403
127	Weapons Support	1.28	750, 751, 810
128	Nuclear Weapons	1.29	615, 703
130	AVIATION	1.3	
131	Operations & Control	1.31	496, 613**
132	Aircraft Stowage, Handling & Maintenance	1.32, 1.33, 1.34	523, 524, 525, 805
133	Aviation Stores	1.35	809, 811
134	Aviation Liquids	1.36	815, 819
135	Aviation Ordnance	1.37	712, 804
140	AMPHIBIOUS WARFARE	1.4	801, 808
150	CARGO TRANSPORT	1.5	720, 821

*Modification to the 1965 B.S.C.I. Weight Groups are found in Table 23.

**Weight applied to more than one functional grouping.

TABLE 22 (continued)

ITEM NUMBER	FUNCTIONAL NAME	U.S. NAVY SHIP SPACE CLASSIFICATION SYSTEM NUMBER (Reference 17)	NAVSHIPS B.S.C.I. WEIGHT Group (1965)*
160	FLAG	1.6	800**
170	PASSENGER	1.7	802
180	SPECIAL MISSIONS	1.8	529
200	PERSONNEL	Group 2	
210	LIVING	2.1	612**, 505**, 800**
211	Officer Berthing	2.111	
212	Officer Messing	2.112	
213	Officer Bath	2.113	
214	CPO Berthing	2.121	
215	CPO Messing	2.122	
216	CPO Bath	2.123	
217	Crew Berthing	2.131	
218	Crew Messing	2.132	
219	Crew Bath	2.133	
220	SUPPORT	2.2	
221	Administration	2.21	613**
222	Food Preparation & Handling	2.22	611
223	Medical & Dental	2.23	614
224	Personnel Services	2.24	609
225	Recreation & Welfare	2.25	612**
226	Sewage	2.26	594
230	STOWAGE	2.3	
231	Personnel Stores (Provisions)	2.31	806
232	Personnel Stowage	2.32	608**, 800**
233	Potable Water	2.33	812
300	SHIP OPERATIONS	Group 3	
310	CONTROL	3.1	
311	Ship Control	3.11	400, 401, 410, 411
312	Damage Control	3.13	
313	Offices	3.14	613**
320	MACHINERY SYSTEMS	3.2, 3.31, 3.33	

TABLE 22 (continued)

ITEM NUMBER	FUNCTIONAL NAME	U.S. NAVY SHIP SPACE CLASSIFICATION SYSTEM NUMBER (Reference 17)	NAVSHIPS B.S.C.I. WEIGHT Group (1965)*
321	Machinery Box	3.21, 3.22, 3.23, 3.24, 3.25, 3.27, 3.12, 3.31, 3.33	200, 201, 202, 204, 206, 207, 208, 209, 210, 211, 251, 300, 301, 351, 502, 503, 504**, 512, 513, 514, 517, 527, 551, 603**
322	Uptakes	3.26	205
323	Shafting, Bearings & Propellers	3.28	203
324	Maneuvering	3.311	518, 519
325	Ventilation	3.313	501**
330	DECK AUXILIARIES	3.32	
331	Anchor Handling, Mooring & Towing	3.321, 3.322	520, 600
332	Underway Replenishment	3.323	528
340	MAINTENANCE	3.4	
341	Mechanical	3.41	610**
342	Electrical	3.42	610**
343	Miscellaneous	3.43	610**, 602, 605
350	STOWAGE	3.5	
351	Fuel Oil	3.511	816
351	Reserve Feed Water	3.512	813
353	Lube Oil	3.513	814
354	Diesel Oil	3.511	817
355	Misc. Liquid	3.514	818, 820
356	Stores & Supplies	3.52	608**, 250, 350, 550, 650, 807
357	Boats	3.53	601
360	TANKAGE	3.6	
361	Ballast	3.61	822
362	Peak Tanks	3.62	
363	Voids	3.64	
364	Cross Flooding	3.65	
365	Misc. Tanks	3.63	
370	PASSAGEWAYS & ACCESS	3.7	603**

TABLE 22 (continued)

ITEM NUMBER	FUNCTIONAL NAME	U.S. NAVY SHIP SPACE CLASSIFICATION SYSTEM NUMBER (Reference 17)	NAVSHIPS B.S.C.I. WEIGHT Group (1965)*
380	HULL MARGIN		
390	SUPERSTRUCTURE MARGIN		
400	HULL	Group 4	
410	Basic Hull Structure		100, 101, 107**, 150**
420	Secondary Structures		116, 122, 123, 125, 127, 128, 150**, 510, 604, 113, 107**, 102, 103, 112, 114, 115, 118, 119, 120, 121
430	Deckhouse Structure		111
440	Armor		117
450	Free Flooding Liquids		151
500	SHIP SYSTEMS		302, 303, 500, 506, 507, 501**, 508, 511, 516, 521, 522, 526, 606, 607, 651, 825, 509, 505**

TABLE 23

MODIFIED BSCI WEIGHT GROUPS

<u>Sub Group</u>	<u>Description</u>
Hull Structure--Group 1	
100	Shell Plating
101	Longitudinal & Transverse Framing
102	Inner Bottom Plating
103	Platforms & Flats
107	All Decks (BSCI 104 thru 110)
111	Superstructure
112	Propulsion Foundations
113	Foundations for Aux. & Other Equip.
114	Structural Bulkheads
115	Trunks & Enclosures
116	Structural Sponsons
117	Armor
118	Aircraft Saddle Tank Structure
119	Castings & Forgings
120	Sea Chests
121	Ballast & Buoyancy Units
122	Special Doors & Closures
123	Doors & Hatches (BSCI 123 & 124)
125	Masts & Kingposts
127	Sonar Domes
128	Towers & Platforms
150	Welding, Riveting & Fastenings
151	Free Flooding Liquids
Propulsion--Group 2	
200	Boilers and Energy Converters (Includes Nuclear)
201	Propulsion Units
202	Main Condensers & Air Ejectors
203	Shafting, Bearings & Propellers
204	Combustion Air Supply
205	Uptakes & Smoke Pipes
206	Propulsion Control Equipment
207	Main Steam System
208	Feed Water & Condensate System
209	Circulating & Cooling Water System
210	Fuel Oil Service Systems
211	Lubricating Oil System
250	Propulsion Repair Parts
251	Propulsion Operating Fluids
Electric Plant--Group 3	
300	Electric Power Generation

TABLE 23 (continued)

<u>Sub Group</u>	<u>Description</u>
301	Power Distribution Switchboards
302	Power Distribution System (Cable)
303	Lighting System
350	Electric Plant Repair Parts
351	Electric Power Generator Fluids
 Communication and Control--Group 4	
400	Navigation Equipment
401	Interior Communication Systems
402	Gun Fire Control Systems
403	Countermeasure System (Non-Electronic)
404	Electronic Countermeasure Systems (ECM)
405	Missile Fire Control Systems
406	ASW Fire Control & Torpedo Fire Control System
407	Torpedo Fire Control System-- Submarines
408	Radar Systems
409	Radio Communication Systems
410	Electronic Navigation Systems
411	Space Vehicle Electronic Tracking Systems
412	Sonar Systems
413	Electronic Tactical Data Systems
415	Electronic Test, Checkout & Monitoring Equipment
450	Communication and Control Repair Parts
451	Communication and Control Operating Fluids
 Auxiliary Systems--Group 5	
500	Heating System
501	Ventilation System
502	Air Conditioning System
503	Refrigerating Spaces, Plant & Equipment
504	Gas, HEAF, All Liquid Cargo Piping, Aviation Lube Oil System, Sewage System
505	Plumbing Installations
506	Firemain, Flushing, Sprinkler, S.W. Service Systems
507	Fire Extinguishing System
508	Drainage, Ballast, Stabilizing Tank System

TABLE 23 (continued)

<u>Sub Group</u>	<u>Description</u>
509	Fresh Water System
510	Scuppers and Deck Drains
511	Fuel & Diesel Oil Filling, Venting, Stowage & Transfer System
512	Tank Heating Systems
513	Compressed Air Systems
514	Auxiliary Steam, Exhaust Steam & Steam Drains
515	Buoyancy Control System, Submarines
516	Miscellaneous Piping Systems
517	Distilling Plant
518	Steering Systems
519	Rudders
520	Mooring, Towing, Anchor & Aircraft, Handling System & Deck Machinery
521	Elevators, Moving Stairways, Stores Handling Systems
522	Operating Gear for Retracting & Elevating Units
523	Aircrafts Elevators
524	Aircraft Arresting Gear, Barriers & Barricades
525	Catapults and Jet Blast Deflectors
526	Hydrofoils
527	Diving Planes & Stabilizing Fins
528	Replenishment at Sea & Cargo Handling
550	Auxiliary Systems Repair Parts
551	Auxiliary Systems Operating Fluids

Outfit and Furnishings--Group 6

600	Hull Fittings
601	Boats, Boat Stowage & Handling
602	Rigging & Canvas
603	Ladders & Gratings
604	Nonstructural Bulkheads & Doors
605	Painting
606	Deck Covering
607	Hull Insulation
608	Storerooms, Stowages & Lockers
609	Equipment for Utility Spaces
610	Equipment for Workshops, Labs & Test Areas
611	Equipment for Galley, Pantry, Scullery & Commissary Outfit
612	Furnishings for Living Spaces
613	Furnishings for Offices, Control Centers & Machinery Spaces

TABLE 23 (continued)

<u>Sub Group</u>	<u>Description</u>
614	Furnishings for Medical, Dental Spaces
615	Radiation Shielding
650	Outfit & Furnishings, Repair Parts
651	Outfit & Furnishings, Operating Fluids
Armament--Group 7	
700	Guns, Gun Mounts, Ammo Handling & Storage (BSCI 700, 701, 702)
703	Special Weapons Handling & Stowage
704	Rocket & Missile Launching, Handling & Stowage Devices (BSCI 704, 705, 706, 707)
708	Torpedo Tubes, Torpedo Handling & Stowage
710	Mine Handling Systems & Stowage
711	Small arms & Pyrotechnic Stowage
712	Air Launched Weapons Handling & Stowage (BSCI 712, 713)
720	Cargo Munitions Handling & Stowage
750	Armament Repair Parts
751	Armament Operating Fluids
Loads--Group 8	
800	Ships Officers, Crew & Effects
801	Troops & Effects
802	Passengers & Effects
803	Ships Ammo
804	Aviation Ammo
805	Aircraft
806	Provisions and Personnel Stores
807	General Stores
808	Marines Stores
809	Aero Stores
810	Ordnance Stores Ship
811	Ordnance Stores AV
812	Potable Water
813	Reserve Feed Water
814	Lube Oil Ship
815	Lube Oil Aviation
816	Fuel Oil
817	Diesel Oil
818	Gasoline
819	JP-5
820	Miscellaneous Liquids

TABLE 23 (continued)

<u>Sub Group</u>	<u>Description</u>
821	Cargo
822	Ballast Water
825	Future Development Margin

APPENDIX D

DERIVED EQUATIONS LISTING

APPENDIX D

DERIVED EQUATIONS LISTING

This appendix provides a listing of the equations which were derived to provide the standard calculations required by the computer program. The data used were taken from References (1), (4), (6), (9), (10), (12), (14), (16), (21), (22), and (23).

The technique used to develop most of the relationships listed in this appendix was linear regression for two variables by the method of least squares. In each case several combinations of variables were tried to determine which gave the best correlation. A coefficient of determination was calculated for each try to give an indication of how closely the equation fit the data. Data points available for each calculation were examined in an effort to insure that only appropriate ship values were used in deriving a particular equation.

In a few instances equations were developed to best fit existing curves, e.g., linear approximations to the powering worm curve used in horsepower calculations. Also, in a few cases where insufficient data was available or a satisfactory variable correlation could not be attained, an average value was selected as the value to be used.

Starting Estimates

$$DPTRY = 0.00076 \text{ LBP}^{2.57}$$

LBP input item

$$DPTRY = 7.0754 \text{ WPAYIN} + 914.45$$

LBP not input item

$$KGTRY = 0.1589 \text{ LBP}^{.7771}$$

Ship Geometry

$$C_{wp} = 0.425 C_B + 0.526$$

$$C_{\alpha} = 0.0733 C_p + 0.0026$$

Speed/Power

$$VMAX = 8.696(\text{SHP/LBP})^{.2668}$$

$$\text{EHPAPP} = 1.3 \text{ EHPBH}$$

$$\text{SLRAT} \leq 0.85$$

$$\text{EHPAPP} = (1.4587 - 0.1867 \text{ SLRAT})\text{EHPBH}$$

$$0.85 < \text{SLRAT} \leq 1.6$$

$$\text{EHPAPP} = (1.310 - 0.0938 \text{ SLRAT})\text{EHPBH}$$

$$1.6 < \text{SLRAT} \leq 1.92$$

$$\text{EHPAPP} = 1.13 \text{ EHPBH}$$

$$\text{SLRAT} > 1.92$$

$$\text{EHP} = 1.1 \text{ EHPAPP}$$

$$\text{SLRAT} \leq 0.70$$

$$\text{EHP} = (1.205 - 0.150 \text{ SLRAT})\text{EHPAPP}$$

$$0.70 < \text{SLRAT} \leq 0.82$$

$$\text{EHP} = (1.3827 - 0.3667 \text{ SLRAT})\text{EHPAPP}$$

$$0.82 < \text{SLRAT} \leq 1.18$$

$$\text{EHP} = (1.1109 - 0.1364 \text{ SLRAT})\text{EHPAPP}$$

$$1.18 < \text{SLRAT} \leq 1.4$$

$$\text{EHP} = (0.9753 - 0.0395 \text{ SLRAT})\text{EHPAPP}$$

$$1.4 < \text{SLRAT} \leq 1.78$$

$$\text{EHP} = (0.8645 + 0.0227 \text{ SLRAT})\text{EHPAPP}$$

$$\text{SLRAT} > 1.78$$

Electric Loads

Cruise KW Loads

$$\text{ECR}(1) = (0.00173\text{FLDISP} \times \text{VSUS} - 64.62)\text{A}$$

$$\text{ECR}(2) = (0.0517\text{FLDISP} + 19.27)\text{E}$$

$$\text{ECR}(3) = 2.0$$

$$\text{ECR}(4) = 6.9$$

$$\text{ECR}(5) = 0.2041\text{WGP4} + 172.71$$

$$\text{ECR}(6) = 25.6$$

$$\text{ECR}(7) = 0.0169\text{FLDISP} + 59.38$$

$$\text{ECR}(8) = 0.1649\text{FLDISP} - 344.33 \quad \text{Steam heat}$$

$$\text{ECR}(8) = 0.1320\text{FLDISP} + 438.96 \quad \text{Electric heat}$$

$$\text{ECR}(9) = 110.0$$

A = 1.0; E = 1.0 Any propulsion plant except nuclear

A = 4.0; E = 2.0 Nuclear propulsion plant

Battle KW Loads

$$\text{EBT}(1) = (0.00209\text{FLDISP} \times \text{VSUS} - 99.19)A$$

$$\text{EBT}(2) = (0.0746\text{FLDISP} - 14.21)E$$

$$\text{EBT}(3) = 1.5$$

$$\text{EBT}(4) = 1.2$$

$$\text{EBT}(5) = 0.3613\text{WGP4} + 174.52$$

$$\text{EBT}(6) = 1.670\text{WTGP7} - 63.79$$

$$\text{EBT}(7) = 0.00794\text{FLDISP} + 64.70$$

$$\text{EBT}(8) = 0.0382\text{FLDISP} + 193.40$$

$$\text{EBT}(9) = 214.6$$

A = 1.0; E = 1.0 Any propulsion plant except nuclear

A = 4.0; E = 2.0 Nuclear propulsion plant

24 Hour KW Average Loads

$$\text{EAV}(1) = (0.00115\text{FLDISP} \times \text{VSUS} + 7.63)A$$

$$\text{EAV}(2) = (0.0705\text{FLDISP} - 80.54)E$$

$$\text{EAV}(3) = 0.3$$

$$\text{EAV}(4) = 5.4$$

$$\text{EAV}(5) = 0.3322\text{WGP4} + 143.17$$

$$\text{EAV}(6) = 12.1$$

$$\text{EAV}(7) = 0.00462\text{FLDISP} + 123.03$$

$$EAV(8) = 0.1021FLDISP - 114.19$$

Steam heat

$$EAV(8) = 0.1252FLDISP + 343.10$$

Electric heat

$$EAV(9) = 99.4$$

A = 1.0; E = 1.0 Any propulsion plant except nuclear

A = 4.0; E = 2.0 Nuclear propulsion plant

Machinery Box Minimum Depth

$$DEPMB = CVK + HCOR + HABCVK$$

$$CVK = 0.2B - 6.0$$

$$HCOR = -10.0C_x + 9.0$$

$$HABCVK = 0.00025SHP/NSHFT + 20.5$$

PPTYP = 1,2,3,4
NB/NSHFT = 1

$$HABCVK = 0.000125SHP/NSHFT + 20.0$$

PPTYP = 1,2,3,4
NB/NSHFT > 1

$$HABCVK = 19.0$$

PPTYP = 5,6,7,8
NSHFT = 1

$$HABCVK = 21.5$$

PPTYP = 5,6,7,8
NSHFT > 1

Weight (BSCI Groups Modified)

Hull Structure--Group 1

$$W(100) = (0.0677 FLDISP + 25.26)C$$

$$W(101) = (0.0532 FLDISP - 55.38)C$$

$$W(102) = 0.0$$

FLDISP \leq 4600

$$W(102) = (0.0120 FLDISP + 9.27)C$$

FLDISP > 4600

$$W(103) = (0.00581 FLDISP^{1.159})C$$

$$W(107) = (0.0694 FLDISP - 62.51)C$$

$$W(111) = 0.00778 VOLSST^{0.820}$$

Aluminum superstructure

$$W(111) = 0.00199 VOLSST - 16.44$$

Steel superstructure

$$W(112) = (0.00101SHP/(NB \times NSHFT) - 3.51)NB \times NSHFT \times C \quad PPTYP = 2$$

$W(112) = (0.5428 \text{ SHP}^{0.3348})C$ PPTYP = 1
 $W(112) = (0.00204\text{SHP})C$ PPTYP = 7
 $W(112) = (0.000818\text{SHP}/(\text{NR} \times \text{NSHFT}) + 40.65)\text{NR} \times \text{NSHFT} \times C$ PPTYP = 4
 $W(112) = (0.000239\text{SHP}/(\text{NE} \times \text{NSHFT}) + 16.18)\text{NE} \times \text{NSHFT} \times C$
PPTYP = 5,6,8
 $W(112) = (0.000714\text{SHP})C$ PPTYP = 3
 $W(113) = (0.000189 \text{ VOLHUL} - 11.68)C$
 $W(114) = (0.000285 \text{ VOLHUL} + 22.83)C$ NON Nuclear Propulsion
 $W(114) = (0.000658 \text{ VOLHUL} - 115.89)C$ Nuclear propulsion
 $W(115) = 0.0000527 \text{ VOLTOT} - 4.47$
 $W(116) = \text{Input Item}$
 $W(117) = \text{Input Item}$
 $W(118) = \text{Input Item}$
 $W(119) = (0.0000708 \text{ VOLTOT} + 0.94)C$
 $W(120) = 3.03 \times 10^{-8} \text{VOLMB}^{1.56}$ PPTYP = 5,6,7,8
 $W(120) = 8.42 \times 10^{-8} \text{VOLMB}^{1.53}$ PPTYP = 1,2,3,4
 $W(121) = \text{Input Item}$
 $W(122) = 0.0$ FLDISP < 7600
 $W(122) = 0.00342\text{FLDISP} - 18.51$ FLDISP \geq 7600
 $W(123) = 0.0000383\text{VOLTOT} - 1.89$
 $W(125) = 0.000278\text{FLDISP} + 3.62$
 $W(127) = \text{Input Item}$
 $W(128) = \text{Input Item}$
 $W(150) = (0.000527\text{VOLTOT}^{0.8314})C$
 $W(151) = \text{Input Item}$

 $C = 1.0$ Steel Hull
 $C = 0.55$ Aluminum Hull

Propulsion--Group 2

W(200) = 0.0 PPTYP = 5,6,7

W(200) = 0.00234SHP + 48.09 PPTYP = 2

W(200) = 0.000883SHP PPTYP = 8

W(200) = 0.00288SHP + 21.92 PPTYP = 1

W(200) = 0.00234SHP - 14.00 PPTYP = 3

W(200) = 0.000183SHP^{1.456} PPTYP = 4

W(201) = 0.00143SHP + 17.92 PPTYP = 2,3

W(201) = 0.00175SHP + 13.25 PPTYP = 1

W(201) = 0.000761SHP^{1.119} PPTYP = 4

W(201) = 0.0124SHP + 5.25 PPTYP = 7

W(201) = 0.00283SHP + 2.68 PPTYP = 5,6

W(201) = 0.00247SHP PPTYP = 8

W(202) = 0.0 PPTYP = 5,6,7

W(202) = 0.000766SHP + 2.98 PPTYP = 1

W(202) = 0.000457SHP + 2.57 PPTYP = 2,3

W(202) = 0.00923SHP^{0.7935} PPTYP = 4

W(202) = 0.000533SHP PPTYP = 8

W(203) = WSHAFT + WPROP + WBRGS

WSHAFT = F x LBP x NSHFT(0.0275(SHP/(NSHFT x RPM))^{2/3})^{0.8768}

Solid Shaft

WSHAFT = F x LBP x NSHFT(0.0134(SHP/(NSHFT x RPM))^{2/3})^{0.9497}

Hollow Shaft, Fixed Pitch Prop.

WSHAFT = F x LBP x NSHFT(1 + .5NSHFT)
x (0.0134(SHP/(NSHFT x RPM))^{2/3})^{0.9497}

Hollow Shaft, Controllable Pitch Prop.

RPM = 96.12VSUS/DPROP + 52.15

$$DPROP = 2.603H^{0.629}$$

$$DPROP = 4.281H^{0.4283}$$

$$F = 0.36$$

$$F = 0.20$$

$$WPROP = (0.00146DPROP^{3.279})NSHFT$$

$$WPROP = (0.00314DPROP^{3.128})NSHFT$$

$$WBRGS = 0.15(WSHAFT + WPROP)$$

$$W(204) = 0.0$$

$$W(204) = 0.000119SHP + 12.22$$

$$W(204) = 0.000119SHP + 10.14$$

$$W(204) = 0.000105SHP + 6.50$$

$$W(204) = 0.000196SHP$$

$$W(204) = 0.000503(SHP + \frac{KWINST}{.8 \times .746})$$

$$W(204) = 0.000267SHP$$

$$W(205) = 0.0$$

$$W(205) = 0.000317SHP$$

$$W(205) = 0.00140(SHP + \frac{KWINST}{.8 \times .746})$$

$$W(205) = 0.00209SHP$$

$$W(205) = 0.000181SHP + 3.18$$

$$W(205) = 0.000136SHP + 14.14$$

$$W(205) = 0.000136SHP + 6.54$$

$$W(206) = 0.000500SHP$$

$$W(206) = 4.0 NSHFT$$

$$W(206) = 0.00144SHP$$

$$W(206) = 0.0000525SHP + 3.90$$

$$W(207) = 0.0$$

$$W(207) = 0.0000833SHP$$

One Shaft

Two Shafts

PPTYP = 1,2,3,4

PPTYP = 5,6,7,8

Fixed Pitch Prop.

Controllable Pitch Prop.

PPTYP = 4,7

PPTYP = 2

PPTYP = 3

PPTYP = 1

PPTYP = 5,6 SSETYP = 4,5,6

PPTYP = 5,6 SSETYP = 2,3

PPTYP = 8

PPTYP = 4

PPTYP = 5,6,8 SSETYP = 4,5,6

PPTYP = 5,6,8 SSETYP = 2,3

PPTYP = 7

PPTYP = 1

PPTYP = 2

PPTYP = 3

PPTYP = 8

PPTYP = 1,2,3,4

PPTYP = 7

PPTYP = 5,6

PPTYP = 5,6,7

PPTYP = 8

$W(207) = 0.000544SHP - 1.70$	PPTYP = 2,3
$W(207) = 0.000586SHP - 5.68$	PPTYP = 1
$W(207) = 33.52SHP^{0.0392}$	PPTYP = 4
$W(208) = 0.0$	PPTYP = 5,6,7
$W(208) = 0.0001833SHP$	PPTYP = 8
$W(208) = 2.592SHP^{0.3105}$	PPTYP = 4
$W(208) = 0.000610SHP + 10.42$	PPTYP = 2,3
$W(208) = 0.000564SHP + 7.48$	PPTYP = 1
$W(209) = 0.0$	PPTYP = 5,6 SSETYP = 2,3
$W(209) = 0.000890KWINST$	PPTYP = 5,6 SSETYP = 4,5,6
$W(209) = 0.00111(SHP + \frac{KWINST}{.8 \times .746})$	PPTYP = 7
$W(209) = 1.32 \times 10^{-8}(SHP + \frac{KWINST}{.8 \times .746})^{1.8642}$	PPTYP = 4
$W(209) = 0.000192(SHP + \frac{KWINST}{.8 \times .746}) + 4.02$	PPTYP = 1,2,3
$W(209) = 0.000300SHP$	PPTYP = 8
$W(210) = 0.0$	PPTYP = 4
$W(210) = 0.00882W(816) + 3.25$	PPTYP = 1,2,3,5,6,8
$W(210) = 0.00882W(817) + 3.25$	PPTYP = 7
$W(211) = 0.000267SHP$	PPTYP = 8
$W(211) = 0.000156SHP + 4.82$	PPTYP = 1,2,3
$W(211) = 0.0443SHP^{0.560}$	PPTYP = 4
$W(211) = 3.10 \times 10^{-7}SHP^{1.641}$	PPTYP = 5,6
$W(211) = 0.00193SHP$	PPTYP = 7
$W(250) = 45.0$	PPTYP = 4
$W(250) = 5.0$	PPTYP = 1,2,3,5,6,7,8 NSHFT = 1
$W(250) = 10.0$	PPTYP = 1,2,3,5,6,7,8

NSHFT = 2

W(251) = 0.000668SHP + 12.14

PPTYP = 1,2,3

W(251) = 0.0972(W(200) + W(201) + W(202) + W(207) + W(208)

+ W(209) + W(211)) - 69.57 PPTYP = 4

W(251) = 1.152(W(209) + W(210) + W(211)) - 10.10

PPTYP = 5,6

W(251) = 0.618(W(209) + W(210) + W(211))

PPTYP = 7

W(251) = 0.000633SHP

PPTYP = 8

Electric Plant--Group 3

W(300) = NLSD(0.0424KWPRD + 0.44) + NMSD(0.0240KWPRD + 0.05)

+ NHSD(0.0137KWPRD + 0.32) + NGTG(0.00424KWPRGT + 16.4)

+ NSTG(0.0167KWPRSG - 1.63)

W(301) = 0.00300KWINST + 2.61

W(302) = 2.15 x 10⁻⁸VOLTOT^{1.623}

VOLTOT < 400,000

W(302) = 0.000170VOLTOT - 48.83

VOLTOT ≥ 400,000

W(303) = 0.0000367VOLTOT - 0.73

W(350) = 0.000348KWINST + 1.96

W(351) = Input Item

Communication and Control--Group 4

W(400) = 0.000350V(311) + 1.62

W(401) = 0.0000508VOLTOT - 2.90

W(402) = Input Item

W(403) = 0.00333FLDISP + 0.12

W(404) = Input Item

W(405) = Input Item

W(406) = W(486) + W(496)

W(486) = Input Item

W(496) = Input Item

$$W(407) = 0.0$$

$$W(408) = \text{Input Item}$$

$$W(409) = \text{Input Item}$$

$$W(410) = 2.0$$

$$W(411) = \text{Input Item}$$

$$W(412) = \text{Input Item}$$

$$W(413) = \text{Input Item}$$

$$W(415) = \text{Input Item}$$

$$W(450) = 0.0317(W(400) + W(401) + \dots + W(413) + W(415)) + 0.82$$

$$W(451) = \text{Input Item}$$

Auxiliary Systems--Group 5

$$W(500) = 7.72 \times 10^{-8} \text{VOLTOT}^{1.443} \quad \text{Electric heat}$$

$$W(500) = 0.0000110 \text{VOLTOT} + 0.76 \quad \text{Steam heat}$$

$$W(501) = 0.0000728 \text{VOLTOT} + 4.57$$

$$W(502) = 0.0000346 \text{VOLTOT} + 4.96$$

$$W(503) = 0.0205 \text{NACC} + 3.66$$

$$W(504) = 0.000728 \text{FLDISP} - 1.98 + W(594)$$

$$W(594) = \text{Input Item}$$

$$W(505) = 0.00107(V(213) + V(216) + V(219)) - 0.96$$

$$W(506) = 0.0000471 \text{VOLTOT} + 6.63$$

$$W(507) = 0.000619 \text{VOLTOT}^{0.7224}$$

$$W(508) = 0.0000243 \text{VOLHUL} + 2.15$$

$$W(509) = 0.00170V(233) + 3.18$$

$$W(510) = 0.00756 \text{LBP} - 0.75$$

$$W(511) = 0.0 \quad \text{PPTYP} = 4$$

$$W(511) = 0.0276W(816) + 4.50 \quad \text{PPTYP} = 1,2,3,5,6,8$$

$$W(511) = 0.0276W(817) + 4.50 \quad \text{PPTYP} = 7$$

W(512) = 0.00323W(816) + 1.01	PPTYP = 1,2
W(512) = 0.0	PPTYP = 3,4,5,6,7,8
W(513) = 0.0000959V(321) - 4.50	PPTYP = 1,2,4
W(513) = 0.00132SHP	PPTYP = 7
W(513) = 0.000426SHP	PPTYP = 3
W(513) = 0.000274SHP + 11.78	PPTYP = 5,6,8
W(514) = 0.000667SHP ^{1.406}	PPTYP = 1,2,3,4
W(514) = 0.0000120VOLTOT	PPTYP = 5,6,7,8 Steam heat
W(514) = 0.0	PPTYP = 5,6,7,8 Electric heat
W(515) = 0.0	
W(516) = 0.0	PPTYP = 1,2,3,5,6,7,8
W(516) = 20.0	PPTYP = 4
W(517) = 0.0000944V(321) - 0.86	PPTYP = 1,2,3
W(517) = 0.0783NACC ^{0.8847}	PPTYP = 4
W(517) = 0.0172NACC + 2.37	PPTYP = 5,6,7,8
W(518) = 0.0000681FLDISP x VSUS + 3.89	
W(519) = 0.000194FLDISP x VSUS - 0.08	
W(520) = 0.00860FLDISP - 2.49	
W(521) = 9.14 x 10 ⁻⁶ VOLTOT + 0.38	
W(522) = Input Item	
W(523) = Input Item	
W(524) = Input Item	
W(525) = Input Item	
W(526) = Input Item	
W(527) = 0.00731FLDISP - 1.20	Fin stabilizers
W(527) = 0.0	No fin stabilizers
W(528) = Input Item	

$$W(550) = 3.5$$

$$W(551) = 0.0000417VOLTOT - 4.93$$

Outfit and Furnishings--Group 6

$$W(600) = 0.00230FLDISP + 3.61$$

$$W(601) = 0.0971NACC - 1.27$$

$$W(602) = 1.0$$

$$W(603) = 27.35FLDISP^{0.0826}$$

PPTYP = 4

$$W(603) = 0.0000403VOLTOT + 6.70$$

PPTYP = 1,2,3,5,6,7,8

$$W(604) = 0.0000321VOLTOT + 3.50$$

$$W(605) = 0.0000641VOLTOT + 4.26$$

$$W(606) = 0.0000408VOLTOT - 5.61$$

$$W(607) = (0.0000717VOLHUL + 10.56) \times \frac{1}{C}$$

$$W(608) = 0.0000712VOLTOT - 2.50$$

$$W(609) = 0.00113V(224) - 0.19$$

$$W(610) = 0.00211(V(341) + V(342) + V(343)) - 3.25$$

$$W(611) = 0.0152NACC + 7.37$$

$$W(612) = 0.000271V(210) + 3.09$$

$$W(613) = 0.000921(V(221) + V(313)) + 1.51$$

Non flag ship

$$W(613) = 0.000505(V(221) + V(313) + V(160)) + 3.54$$

Flag ship

$$W(614) = 0.000265V(223) + 0.58$$

$$W(615) = 0.404W(703)$$

$$W(650) = 0.00290(W(600) + \dots W(615) + W(651)) + 0.93$$

$$W(651) = \text{Input Item}$$

$$C = 1.0$$

Steel hull

$$C = 0.55$$

Aluminum hull

Armament--Group 7

$$W(700) = \text{Input Item}$$

W(703) = Input Item

W(704) = W(774) + W(784)

W(774) = Input Item

W(784) = Input Item

W(708) = Input Item

W(710) = Input Item

W(711) = Input Item

W(712) = Input Item

W(720) = 0.0

W(750) = 0.0101(W(700) + W(703) + W(704) + W(708) + W(710)
+ W(711) + W(712)) + 4.66

W(751) = 0.0173(W(700) + W(703) + W(704) + W(708) + W(710) + W(711)
+ W(712)) - 0.88

Loads

W(800) = 0.0737NACSC + 0.105NOFF + 0.073NCPO + 0.029ONCREW
+ 0.0737NFLAG + 0.0737NFLAG

W(801) = 0.0737NTRP + 0.037ONTRP

W(802) = 0.0737NPASS + 0.029ONPASS

W(803) = W(873) + W(883) + W(893)

W(873) = Input Item

W(883) = Input Item

W(893) = Input Item

W(804) = Input Item

W(805) = Input Item

W(806) = 0.0164(NACC x DUR)^{0.8333}

W(807) = 0.000755(NACC x DUR) + 1.81

W(808) = Input Item

W(809) = Input Item

W(810) = Input Item

W(811) = Input Item

W(812) = 0.0530NACC^{1.214}

W(813) = 0.0

PPTYP = 5,6,7

W(813) = 0.2022SHP^{0.530}

PPTYP = 1,8

W(813) = 0.000583SHP^{1.057}

PPTYP = 2,3

W(813) = 0.00362SHP^{0.9466}

PPTYP = 4

W(814) = 0.0000388SHP + 3.08

PPTYP = 1

W(814) = 0.00286SHP^{0.7649}

PPTYP = 2,3

W(814) = 5.51 x 10⁻⁶SHP^{1.387}

PPTYP = 4

W(814) = 0.00398SHP

PPTYP = 7

W(814) = 4.366SHP^{0.1122}

PPTYP = 5,6,8

W(815) = Input Item

W(816) = 0.0

PPTYP = 4

W(816) = ($\frac{\text{ENDUR} \times \text{FRSTM}}{\text{VEND} \times 2240}$)(1.18)

PPTYP = 1,2,3

FRSTM = 0.5882AVEDPW + 1303.92

AVEDPW = 1.10SHPE

W(816) = WFPROP + WFELEC + WFAUXB

PPTYP = 5,6,7,8

WFPROP = 0.0

PPTYP = 7

WFPROP = ($\frac{\text{ENDUR} \times \text{FRCGAS}}{\text{VEND} \times 2240}$)(1.18)

PPTYP = 8

FRCGAS = 2589. + 0.288SHP

WFPROP = ($\frac{\text{ENDUR} \times \text{AVEDPW} \times \text{SFCAED}}{\text{VEND} \times 2240}$)(1.18)

PPTYP = 5,6

AVEDPW = 1.10SHPE

EDPWPE = $\frac{\text{AVEDPW}}{\text{NEEND}}$

NEEND = 1.0

AVEDPW \leq $\frac{\text{SHP}}{\text{NE}}$ Single Shaft

NEEND = 2.0

$\frac{\text{SHP}}{\text{NE}} <$ AVEDPW \leq $\frac{2\text{SHP}}{\text{NE}}$ Single Shaft

$$\begin{aligned}
\text{NEEND} &= 2.0 & \text{AVEDPW} &\leq \frac{2\text{SHP}}{\text{NE}} & \text{Twin shafts} \\
\text{NEEND} &= 4.0 & \frac{2\text{SHP}}{\text{NE}} &< \text{AVEDPW} \leq \frac{4\text{SHP}}{\text{NE}} & \text{Twin shafts} \\
\text{SFCAED} &= \text{SFCFP} \left(1.2298 \left(1 - \frac{\text{EDPWPE}}{\text{SHP/NE}} \right)^{1.6384} + 1.00 \right) \\
\text{SFCFP} &= -0.0000101 \frac{\text{SHP}}{\text{NE}} + 0.717 & \text{PPTYP} &= 5 \\
\text{SFCFP} &= -0.0000101 \frac{\text{SHP}}{\text{NE}} + 0.627 & \text{PPTYP} &= 6 \\
\text{WFELEC} &= 0.0 & \text{SSETYP} &= 4,5,6 \\
\text{WFELEC} &= \left(\frac{\text{ENDUR} \times \text{AVEDPW} \times \text{SFCAED}}{\text{VEND} \times 2240} \right) 1.05 & \text{SSETYP} &= 2,3 \\
\text{AVEDPW} &= \frac{\text{KW24AV}}{.8 \times .746} \\
\text{AEDPWG} &= \frac{\text{AVEDPW}}{\text{NGAVG}} \\
\text{SFCAED} &= \text{SFCFP} \left(1.2298 \left(1 - \frac{\text{AEDPWG}}{\text{KWPRGT}/(.8 \times .746)} \right)^{1.6384} + 1.00 \right) \\
\text{SFCFP} &= -0.0000101 \frac{\text{KWPRGT}}{.8 \times .746} + 0.717 & \text{SSETYP} &= 2 \\
\text{SFCFP} &= -0.0000101 \frac{\text{KWPRGT}}{.8 \times .746} + 0.627 & \text{SSETYP} &= 3 \\
\text{WFAUXB} &= \frac{\text{ENDUR} \times \text{FRAUXB}}{\text{VEND} \times 2240} 1.05 \\
\text{FRAUXB} &= 1.044 \times \text{NACC} \\
\text{W(817)} &= 0.1432\text{KWEMER} - 5.60 & \text{PPTYP} &= 1,2,3,4 \\
\text{W(817)} &= \text{WFPROP} + \text{WFELEC} \\
\text{WFPROP} &= 0.0 & \text{PPTYP} &= 1,2,3,4,5,6,8 \\
\text{WFPROP} &= \frac{\text{ENDUR} \times \text{AVEDPW} \times \text{SFCAED}}{\text{VEND} \times 2240} 1.18 & \text{PPTYP} &= 7 \\
\text{AVEDPW} &= 1.10\text{SHPE} \\
\text{EDPWPE} &= \frac{\text{AVEDPW}}{\text{NEEND}} \\
\text{NEEND} &= 1.0 & \text{AVEDPW} &\leq \frac{\text{SHP}}{\text{NE}} & \text{Single Shaft} \\
\text{NEEND} &= 2.0 & \frac{\text{SHP}}{\text{NE}} &< \text{AVEDPW} \leq \frac{2\text{SHP}}{\text{NE}} & \text{Single Shaft} \\
\text{NEEND} &= 2.0 & \text{AVEDPW} &\leq \frac{2\text{SHP}}{\text{NE}} & \text{Twin Shafts} \\
\text{NEEND} &= 4.0 & \frac{2\text{SHP}}{\text{NE}} &< \text{AVEDPW} \leq \frac{4\text{SHP}}{\text{NE}} & \text{Twin Shafts}
\end{aligned}$$

$$\text{RATFP} = \frac{\text{EDPWPE}}{\text{SHP/NE}}$$

$$\text{SFCAED} = 0.274 e^{(-5.166 \times \text{RATFP})} + 0.359$$

$$\text{WFELEC} = 0.0$$

$$\text{SSETYP} = 1,2,3$$

$$\text{WFELEC} = \frac{\text{ENDUR} \times \text{FRDIEG} \times \text{NGAVG}}{\text{VEND} \times 2240} 1.05 \quad \text{SSETYP} = 4,5,6$$

$$\text{FRDIEG} = 1.8845 \frac{\text{KW24AV}^{0.8273}}{\text{NGAVG}}$$

W(818) = Input Item

W(819) = Input Item

W(820) = Input Item

W(821) = Input Item

W(822) = Input Item

W(825) = Input Item

Vertical Center of Gravity

Hull Structure--Group 1

$$\text{VCG}(100) = 0.3661\text{D}10 + 1.45$$

$$\text{VCG}(101) = 0.1999\text{D}10 + 4.94$$

$$\text{VCG}(102) = 0.1139\text{D}10 + 0.91$$

$$\text{VCG}(103) = 1.029\text{H} - 2.59$$

$$\text{VCG}(107) = 0.8289\text{D}10 + 3.54$$

$$\text{VCG}(111) = 1.2334\text{D}10 + 4.44$$

$$\text{VCG}(112) = 0.2324\text{H} + 10.00$$

$$\text{PPTYP} = 4$$

$$\text{VCG}(112) = 0.5784\text{H}$$

$$\text{PPTYP} = 5,6,8$$

$$\text{VCG}(112) = 0.9257\text{H} - 8.68$$

$$\text{PPTYP} = 1,2,3,7$$

$$\text{VCG}(113) = 0.2607\text{H} + 9.94$$

$$\text{VCG}(114) = 0.6216\text{D}10 - 2.54$$

$$\text{VCG}(115) = 0.4623\text{D}10 + 5.27$$

VCG(116) = Input Item

VCG(117) = Input Item
 VCG(118) = 0.4529D10
 VCG(119) = 0.3055D10 + 2.80
 VCG(120) = 0.2436H + 1.29
 VCG(121) = Input Item
 VCG(122) = 0.7288D10
 VCG(123) = 0.8815D10 - 0.14
 VCG(125) = 0.5461D10 + 65.75
 VCG(127) = Input Item
 VCG(128) = Input Item
 VCG(150) = 0.5829D10 + 0.68
 VCG(151) = 0.348H

Propulsion--Group 2

VCG(200) = $0.000271 \frac{\text{SHP}}{\text{NSHFT}}$ + 4.47 PPTYP = 1,2,3,5,6,7,8
 VCG(200) = $0.000322 \frac{\text{SHP}}{\text{NSHFT}}$ + 7.58 PPTYP = 4
 VCG(201) = 0.809H + 1.09
 VCG(202) = 0.5611H + 0.36
 VCG(203) = 0.6603H - 5.54
 VCG(204) = $0.000180 \frac{\text{SHP}}{\text{NSHFT}}$ + 17.45 PPTYP = 1,2,4,7
 VCG(204) = 0.506D10 PPTYP = 3
 VCG(204) = 1.13D10 PPTYP = 5,6,8
 VCG(205) = 1.467D10 + 9.00
 VCG(206) = 0.4381D10 + 6.23
 VCG(207) = 0.5178D10 + 4.94
 VCG(208) = 0.2643D10 + 5.24
 VCG(209) = 0.2234D10 + 1.21
 VCG(210) = 0.4219H + 4.12

$$\text{VCG}(211) = 0.3492\text{D}10 - 1.04$$

$$\text{VCG}(250) = 0.1479\text{D}10 + 11.48$$

$$\text{VCG}(251) = 0.9992\text{H} - 4.74$$

Electric Plant--Group 3

$$\text{VCG}(300) = 0.5829\text{H} + 7.40$$

$$\text{VCG}(301) = 0.4431\text{D}10 + 5.89$$

$$\text{VCG}(302) = 0.4432\text{D}10 + 10.49$$

$$\text{VCG}(303) = 0.8399\text{D}10 + 1.71$$

$$\text{VCG}(350) = 0.5471\text{D}10 - 1.63$$

$$\text{VCG}(351) = 0.3542\text{D}10 + 1.48$$

Communication and Control--Group 4

$$\text{VCG}(400) = 1.1534\text{D}10 + 12.19$$

$$\text{VCG}(401) = 0.7251\text{D}10 + 3.07$$

$$\text{VCG}(402) = \text{Input Item}$$

$$\text{VCG}(403) = 0.5068\text{D}10 + 7.04$$

$$\text{VCG}(404) = \text{Input Item}$$

$$\text{VCG}(405) = \text{Input Item}$$

$$\text{VCG}(406) = \text{Input Item}$$

$$\text{VCG}(407) = \text{Input Item}$$

$$\text{VCG}(408) = \text{Input Item}$$

$$\text{VCG}(409) = \text{Input Item}$$

$$\text{VCG}(410) = 55.0$$

$$\text{VCG}(411) = \text{Input Item}$$

$$\text{VCG}(412) = \text{Input Item}$$

$$\text{VCG}(413) = \text{Input Item}$$

$$\text{VCG}(415) = \text{Input Item}$$

$$\text{VCG}(450) = 0.2659\text{D}10 + 19.89$$

VCG(451) = Input Item

Auxiliary Systems--Group 5

VCG(500) = 0.7209D10 + 3.08

Steam heat

VCG(500) = 0.3867D10

Electric heat

VCG(501) = 0.7663D10 + 7.14

VCG(502) = 0.2779D10 + 11.11

VCG(503) = 2.4468H - 22.62

VCG(504) = 0.8323D10 - 7.28

VCG(505) = 0.6806D10 + 4.26

VCG(506) = 0.8267D10 - 3.33

VCG(507) = 0.7804D10 + 0.95

VCG(508) = 0.1610D10 + 4.71

VCG(509) = 0.4265D10 + 8.39

VCG(510) = 0.2834D10 + 22.42

VCG(511) = 1.2224H - 6.44

VCG(512) = 0.3278H + 0.6557

VCG(513) = 16.4

VCG(514) = 0.8126H + 5.53

PPTYP = 1,2,3,4,7,8

VCG(514) = 0.7735H

PPTYP = 5,6

VCG(515) = Input Item

VCG(516) = 0.308D10

VCG(517) = 0.9938H + 1.73

VCG(518) = 1.8139H - 13.10

VCG(519) = 0.6428H + 2.40

VCG(520) = 0.6252D10 + 3.82

VCG(521) = 0.8655D10 + 8.24

VCG(522) = Input Item

VCG(523) = Input Item

VCG(524) = Input Item

VCG(525) = Input Item

VCG(526) = Input Item

VCG(527) = 0.4878H

VCG(528) = Input Item

VCG(550) = 0.2804D10 + 8.53

VCG(551) = 0.5007D10 + 2.77

Outfit and Furnishings--Group 6

VCG(600) = 0.7772D10 + 11.85

VCG(601) = 1.0081D10 + 10.63

VCG(602) = 1.0183D10 + 10.99

VCG(603) = 0.3082D10 + 7.18

VCG(604) = 0.8684D10 + 3.15

VCG(605) = 0.4282D10 + 7.64

VCG(606) = 0.9046D10 - 1.03

VCG(607) = 0.5420D10 + 10.80

VCG(608) = 0.4503D10 + 7.47

VCG(609) = 0.5927D10 + 5.92

VCG(610) = 0.9440D10 - 4.55

VCG(611) = 0.8384D10 + 2.86

VCG(612) = 0.8037D10 + 1.75

VCG(613) = 1.0519D10 - 0.42

VCG(614) = 0.4172D10 + 15.28

VCG(615) = VCG(703)

VCG(650) = 1.1088D10 - 13.58

VCG(651) = Input Item

Armament--Group 7

VCG(700) = Input Item

VCG(703) = Input Item

VCG(704) = Input Item

VCG(708) = Input Item

VCG(710) = Input Item

VCG(711) = Input Item

VCG(712) = Input Item

VCG(750) = $0.546D10 + 1.44$

VCG(751) = 32.7

Loads

VCG(800) = $0.7076D10 + 1.41$

VCG(801) = VCG(800)

VCG(802) = VCG(800)

VCG(803) = Input Item

VCG(804) = Input Item

VCG(805) = Input Item

VCG(806) = $0.5932D10 - 2.99$

VCG(807) = $0.2840D10 + 13.54$

VCG(808) = Input Item

VCG(809) = Input Item

VCG(810) = Input Item

VCG(811) = Input Item

VCG(812) = 4.2

VCG(813) = 4.7

VCG(814) = $1.1519H - 2.20$

VCG(815) = Input Item

VCG(816) = 0.2515H + 4.27

VCG(817) = 12.5

PPTYP = 1,2,3,4,5,6,8

VCG(817) = VCG(816)

PPTYP = 7

VCG(818) = Input Item

VCG(819) = Input Item

VCG(820) = Input Item

VCG(821) = Input Item

VCG(822) = Input Item

VCG(825) = Input Item

Volumes

Military Mission

V(111) = Input Item

V(112) = Input Item

V(113) = Input Item

V(114) = Input Item

V(115) = Input Item

V(116) = 0.332FLDISP + 1437. + Input Item

V(121) = Input Item

V(122) = Input Item

V(123) = Input Item

V(124) = Input Item

V(125) = Input Item

V(126) = Input Item

V(127) = 0.3577(V(121) + ... + V(126) + V(128))^{0.8958}

V(128) = Input Item

V(131) = Input Item

V(132) = Input Item

V(133) = Input Item

V(134) = Input Item

V(135) = Input Item

V(140) = 572.36NTRP^{0.8906}

V(150) = Input Item

V(160) = 572.36NFLAG^{0.8906}

V(170) = 572.36NPASS^{0.8906}

V(180) = Input Item

Personnel

V(211) = (777.77NOFF - 3906.56)S(2250)

V(212) = (526.83NOFF^{0.6533})S(2251)

V(213) = (128.92NOFF^{0.8878})S(2252)

V(214) = (255.15NCPO + 488.10)S(2253)

V(215) = (89.91NCPO + 584.75)S(2254)

V(216) = (53.78NCPO + 588.04)S(2255)

V(217) = (129.45NCREW + 9828.35)S(2256)

V(218) = (23.12NCREW + 4429.66)S(2257)

V(219) = (26.31NCREW + 573.84)S(2258)

V(221) = 3.33NACC^{1.088}S(2259)

V(222) = 107.22NACC^{0.7933}S(2260)

V(223) = (18.33NACC - 2124.47)S(2261)

V(224) = (16.30NACC + 1316.03)S(2262)

V(225) = (2.91NACC + 1473.42)S(2263)

V(226) = Input Item

V(231) = 0.8642(NACC x DUR)^{0.965}S(2264)

V(232) = (17.22NACC - 623.12)S(2265)

V(233) = (7.172NACC + 793.50)S(2266)

Ship Operations

V(311) = (0.00749LBP ^{2.258})S(2267)	
V(312) = 0.417FLDISP + 1062.74	
V(313) = (0.8889FLDISP + 541.68)S(2268)	
V(321) = 30,851 + 1.472SHP + 7.735(KWINST)	PPTYP = 1,2,3
V(321) = 893.21SHP ^{0.4955}	PPTYP = 7
V(321) = 0.2685(SHP + $\frac{KWINST}{.8 \times .746}$) ^{1.225}	PPTYP = 4
V(321) = 0.8346(SHP + $\frac{KWINST}{.8 \times .746}$) ^{1.084}	PPTYP = 5,6,8
V(322) = 0.4547SHP ^{0.9134}	PPTYP = 1,2,3
V(322) = 2000.0	PPTYP = 4
V(322) = 8.32SHP ^{0.6667}	PPTYP = 7
V(322) = 0.00951(SHP + $\frac{KWINST}{.8 \times .746}$)	PPTYP = 5,6,8
V(323) = 0.0	PPTYP = 5,6,7,8 1 shaft
V(323) = 15.90LBP - 3688.67	PPTYP = 1,2,3,4 1 shaft
V(323) = 0.0000210LBP ^{3.034}	Any plant--2 shafts
V(324) = 0.0183(FLDISP x VSUS) + 2248.70	
V(325) = (2.092FLDISP - 1516.62)S(2269)	
V(331) = 0.6413LBP ^{1.432}	
V(332) = Input Item	
V(341) = (0.8036FLDISP - 200.37)S(2270)	
V(342) = (0.1943FLDISP + 331.42)S(2271)	
V(343) = (0.0291FLDISP ^{1.284})S(2272)	
V(351) = 105.85W(816) ^{0.8532}	PPTYP = 1,2,3,5,6,7,8
V(351) = 0.0	PPTYP = 4
V(352) = 0.5324W(813) ^{1.9287}	
V(353) = 39.0W(814)	

$$V(354) = 27.93W(817)^{1.0798}$$

$$V(355) = 40.0W(820)$$

$$V(356) = 0.5353(NACC \times DUR) + 4422.87$$

$$V(357) = \text{Input Item}$$

$$V(361) = 40.0W(822)$$

$$V(362) = 0.450FLDISP - 145.90$$

$$V(363) = 0.0000238FLDISP^{2.314}$$

$$V(364) = \text{Input Item}$$

$$V(365) = \text{Input Item}$$

$$V(370) = (0.130(VOLTOT - V(370))^{0.9233})S(2773)$$

Centerline passage

$$V(370) = (90.90(VOLTOT - V(370))^{0.4932})S(2273)$$

Port & starboard
passage

$$V(380) = \text{Input Item}$$

$$V(390) = \text{Input Item}$$

APPENDIX E
PROGRAM LISTING

MAIN0001
 MAIN0002
 MAIN0003
 MAIN0004
 MAIN0005
 MAIN0006
 MAIN0007
 MAIN0008
 MAIN0009
 MAIN0010
 MAIN0011
 MAIN0012
 MAIN0013
 MAIN0014
 MAIN0015
 MAIN0016
 MAIN0017
 MAIN0018
 MAIN0019
 MAIN0020
 MAIN0021
 MAIN0022
 MAIN0023
 MAIN0024
 MAIN0025
 MAIN0026
 MAIN0027
 MAIN0028
 MAIN0029
 MAIN0030
 MAIN0031
 MAIN0032
 MAIN0033
 MAIN0034
 MAIN0035
 MAIN0036

```

DIMENSION INDP(3)
INTEGER PPTYP,SSETYP,EMETYP
REAL LBP,KGTRY,LB,LENMB,LRD,MXDIS,MXVCG,LBRAT
REAL*8 NS(100),NTYP(50),NSR(70),NCOMP(400),NWT(830),NELC(20)
COMMON/DATA/P(7,300),S(2500),Q(100),IT(100)
COMMON/CRVALS/CR1(1152),CR2(972),CR3(216)
DATA INDP(1),INDP(2),INDP(3)/2,7,300/
COMMON/WTMOM/W(900),VM(900),VCG(900),WPAYIN,DCMARG,DISPFL,VWT(400)
COMMON/VOLUM/V(400),VOLTOT,VOLSST,VOLHUL,VOLMB,FNDEN(400)
COMMON/ELPT/ECR(11),EBT(11),EAV(11),ELMARG,MXFCCK,KW24AV,HFTYP
COMMON/GENSZ/KWSSER,KWEMER,KWINST,SSETYP,EMETYP,NLSD,NMSD,NHSD,
INGTG,NSTG,KWPRD,KWPRGT,KWPRSG,NGFCLD,NGAVG,NSSG,NEMG,KELEC
COMMON/UND/FSCORR,CP,CX,GMBMIN,KGTRY,B,CWP,LBP,R,LBRAT,BHRAT,DPTRY
COMMON/PROPPW/VSUS,VEND,DELCF,PPTY,JHPOPT,PCMXSP,PCEND,ENDUR
COMMON/MNMACH/SHP,NB,NR,NE,NSHFT,PRPTY,SHFTYP,RPM,DPRODP,SHPE
COMMON/MBDIM/DEPMB,LENMB,BEAMMB
COMMON/PEOPLE/NACC,NOFF,NCPO,NCREW,NFLAG,NTRP,NPASS,DUR,NACSC
COMMON/MISC/FINST,HULMAT,SSMAT,PASTYP
COMMON/WTGRPS/WTGP1,WTGP2,WTGP3,WTGP4,WTGP5,WTGP6,WTGP7,VRLOAD,
IDISPLS,WTMARG,WBHS,WSS,WDHS,WARM,WFFL,WFG4,WFG5,VOLSHIP,WTSHIP
COMMON/CGS/CG1,CG2,CG3,CG4,CG5,CG6,CG7,CGLDS,CGLSP,CGFLD
COMMON/DEPTH/FO,F10,F20,DO,D10,D20,H,DECKHT,LRD,DAVG
COMMON/OUT/PRTOUT,AVSP,EXCKG,ICONST,NSHIP
COMMON/VALUES/NS,NTYP,NSR,NCOMP,NWT,NELC
      SET THE SPECIFICATION NAMES
C      DO 111 I=1,90,10
111 READ 112,NS(I),NS(I+1),NS(I+2),NS(I+3),NS(I+4),NS(I+5),NS(I+6),
      NS(I+7),NS(I+8),NS(I+9)
112 FORMAT (10A8)
C      SET THE TYPE NAMES
C      DO 113 I=1,50,10
113 READ 114,NTYP(I),NTYP(I+1),NTYP(I+2),NTYP(I+3),NTYP(I+4),NTYP(I+5)
      1,NTYP(I+6),NTYP(I+7),NTYP(I+8),NTYP(I+9)
114 FORMAT (10A8)
C      SET THE SUMMARY OF RESULT NAMES
C      DO 115 I=1,70,10
  
```

MAIN0037
 MAIN0038
 MAIN0039
 MAIN0040
 MAIN0041
 MAIN0042
 MAIN0043
 MAIN0044
 MAIN0045
 MAIN0046
 MAIN0047
 MAIN0048
 MAIN0049
 MAIN0050
 MAIN0051
 MAIN0052
 MAIN0053
 MAIN0054
 MAIN0055
 MAIN0056
 MAIN0057
 MAIN0058
 MAIN0059
 MAIN0060
 MAIN0061
 MAIN0062
 MAIN0063
 MAIN0064
 MAIN0065
 MAIN0066
 MAIN0067
 MAIN0068
 MAIN0069
 MAIN0070
 MAIN0071
 MAIN0072

```

115 READ I16,NSR(I),NSR(I+1),NSR(I+2),NSR(I+3),NSR(I+4),NSR(I+5),
    INSR(I+6),NSR(I+7),NSR(I+8),NSR(I+9)
116 FORMAT (10A8)
C      SET THE FUNCTIONAL COMPONENT NAMES
    DO 117 I=100,399,10
117 READ I18,NCOMP(I),NCOMP(I+1),NCOMP(I+2),NCOMP(I+3),NCOMP(I+4),
    INCOMP(I+5),NCOMP(I+6),NCOMP(I+7),NCOMP(I+8),NCOMP(I+9)
118 FORMAT (10A8)
C      SET THE BSCI WEIGHT GROUP NAMES
    DO 129 I=100,829,10
129 READ I30,NWT(I),NWT(I+1),NWT(I+2),NWT(I+3),NWT(I+4),NWT(I+5),
    INWT(I+6),NWT(I+7),NWT(I+8),NWT(I+9)
130 FORMAT (10A8)
C      SET THE ELECTRIC GROUP NAMES
    DO 131 I=1,20,10
131 READ I32,NELC(I),NELC(I+1),NELC(I+2),NELC(I+3),NELC(I+4),NELC(I+5),
    I,NELC(I+6),NELC(I+7),NELC(I+8),NELC(I+9)
132 FORMAT (10A8)
C      READ IN CR ARRAY VALUES FROM TAYLOR SERIES
120 READ I20,CR1
    FORMAT(16F5.0)
121 READ I21,CR2
    FORMAT(9F5.0)
122 READ I22,CR3
    FORMAT(6F5.0)
C      CALL PAYLOAD DATA ONLY ONCE
    DO 2 I=1,7
    DO 2 J=1,300
    2 P(I,J)=0.
    CALL DATA2(P,INDP,2100)
    IF(INDP(1).GE.1) STOP
C      NUMBER THE SHIP BEING CALCULATED
    NSHIP=0
    DO 4 I=1,2500
    4 S(I)=0.
C      ADDITIONAL PROBLEMS START HERE
  
```

MAIN0073
 MAIN0074
 MAIN0075
 MAIN0076
 MAIN0077
 MAIN0078
 MAIN0079
 MAIN0080
 MAIN0081
 MAIN0082
 MAIN0083
 MAIN0084
 MAIN0085
 MAIN0086
 MAIN0087
 MAIN0088
 MAIN0089
 MAIN0090
 MAIN0091
 MAIN0092
 MAIN0093
 MAIN0094
 MAIN0095
 MAIN0096
 MAIN0097
 MAIN0098
 MAIN0099
 MAIN0100
 MAIN0101
 MAIN0102
 MAIN0103
 MAIN0104
 MAIN0105
 MAIN0106
 MAIN0107
 MAIN0108

6 NSHIP=NSHIP+1
 C CALL SPECIFICATIONS AND SPECIAL INPUT ITEMS
 CALL DATA2(S,IND,2500)
 IF(IND.GE.1) STOP
 C TRANSFORM PAYLOAD SPECS TO QUANTITY AND ITEM NUMBER
 MXITM=0
 DO 9 I=1,100
 IF(MXITM=0) 7,7,8
 7 Q(I)=S(98+2*I)
 IT(I)=S(99+2*I)
 IF(Q(I).LT.0) MXITM=I
 GO TO 9
 8 Q(I)=0.
 9 CONTINUE

SYMBOLIZE THE SPECIFICATIONS

C
 VSUS=S(1)
 VEND=S(2)
 ENDUR=S(3)
 LBP=S(4)
 LBRAT=S(5)
 BHRAT=S(6)
 CP=S(7)
 CX=S(8)
 PPTYP=S(11)
 SHP=S(12)
 NB=S(13)
 NR=S(14)
 NE=S(15)
 NSHFT=S(16)
 PRPTYP=S(17)
 SHFTYP=S(18)
 RPM=S(19)
 DPROP=S(20)
 DEPMB=S(21)
 LENMB=S(22)
 BEAMMB=S(23)

PCEND=S(24)
PCMXSP=S(25)
DELCF=S(26)
SSETYP=S(31)
EMETYP=S(32)
NLSD=S(33)
NMSD=S(34)
NHSD=S(35)
NGTG=S(36)
NSTG=S(37)
KWPRD=S(38)
KWPRGT=S(39)
KWPRSG=S(40)
ELMARG=S(41)
HTTYP=S(45)
FINST=S(46)
NOFF=S(50)
NCPO=S(51)
NCREW=S(52)
NFLAG=S(53)
NTRP=S(54)
NPASS=S(55)
DUR=S(56)
HULMAT=S(61)
SSMAT=S(62)
GMBMIN=S(64)
DISTOL=S(66)
MXDIS=S(67)
VCGTOL=S(68)
MXVCG=S(69)
DCMARG=S(70)
FSCORR=S(71)
PRTOUT=S(72)
ICONST=S(73)
PASTYP=S(75)

INITIALIZE ARRAYS FOR MAIN PROGRAM

MAIN0109
MAIN0110
MAIN0111
MAIN0112
MAIN0113
MAIN0114
MAIN0115
MAIN0116
MAIN0117
MAIN0118
MAIN0119
MAIN0120
MAIN0121
MAIN0122
MAIN0123
MAIN0124
MAIN0125
MAIN0126
MAIN0127
MAIN0128
MAIN0129
MAIN0130
MAIN0131
MAIN0132
MAIN0133
MAIN0134
MAIN0135
MAIN0136
MAIN0137
MAIN0138
MAIN0139
MAIN0140
MAIN0141
MAIN0142
MAIN0143
MAIN0144

MAIN0145
 MAIN0146
 MAIN0147
 MAIN0148
 MAIN0149
 MAIN0150
 MAIN0151
 MAIN0152
 MAIN0153
 MAIN0154
 MAIN0155
 MAIN0156
 MAIN0157
 MAIN0158
 MAIN0159
 MAIN0160
 MAIN0161
 MAIN0162
 MAIN0163
 MAIN0164
 MAIN0165
 MAIN0166
 MAIN0167
 MAIN0168
 MAIN0169
 MAIN0170
 MAIN0171
 MAIN0172
 MAIN0173
 MAIN0174
 MAIN0175
 MAIN0176
 MAIN0177
 MAIN0178
 MAIN0179
 MAIN0180

```

DO 11 I=1,900
11 W(I)=VCG(I)=VM(I)=0.
DO 12 I=1,400
12 V(I)=VMT(I)=FNDEN(I)=0.
DO 13 I=1,11
13 ECR(I)=EBT(I)=EAV(I)=0.
      ACCOMMODATIONS
      NACSC=NOFF+NCPO+NGREW
      NACC=NACSC+NFLAG+NTRP+NPASS
      CALL SPAYLD
      CALCULATE PAYLOAD INPUT
      SET VALUE OF DELCF IF NOT SPECIFIED
      IF(DELCF.EQ.0.0) DELCF=0.0004
      KGEOM IS USED TO DETERMINE ROUTING FOR GEOM CALCS
      KGEOM=0
      IF(LBP.GT.0.0) KGEOM=1
      DETERMINE TYPE SPEED-SHP CALC REQUIRED
      JHPOPT=1
      IF(SHP.GT.0.0) JHPOPT=2
      DETERMINE IF ELECTRIC PLANT SIZE GIVEN
      KELEC=0
      IF(NLSD.GT.0.0.OR.NMSD.GT.0.0.OR.NHSD.GT.0.0.OR.NGTG.GT.0.0.OR.NSTG.GT.0.0)
1KELEC=1
      ESTIMATE DISPLACEMENT AND KG AND CALC GEOMETRY
      NDIS=1
      NVCG=1
      EXCKG=0.
      NLEN=0
      IF(KGEOM.EQ.1) GO TO 20
      DPTRY=7.0754*WPAYIN+914.45
45 CALL GEOM
      GO TO 37
20 IF(NDIS.EQ.1) DPTRY=0.00076*LBP**2.57
37 IF(NVCG.EQ.1) KGTRY=.1589*LBP**.7771-2.0
      CALL UWDIM
      IF(LBP.LT.0.0) GO TO 999
  
```

MAIN0181
 MAIN0182
 MAIN0183
 MAIN0184
 MAIN0185
 MAIN0186
 MAIN0187
 MAIN0188
 MAIN0189
 MAIN0190
 MAIN0191
 MAIN0192
 MAIN0193
 MAIN0194
 MAIN0195
 MAIN0196
 MAIN0197
 MAIN0198
 MAIN0199
 MAIN0200
 MAIN0201
 MAIN0202
 MAIN0203
 MAIN0204
 MAIN0205
 MAIN0206
 MAIN0207
 MAIN0208
 MAIN0209
 MAIN0210
 MAIN0211
 MAIN0212
 MAIN0213
 MAIN0214
 MAIN0215
 MAIN0216

```

C
LB=LBP/B
RH=B/H
      CALC SHP GIVEN SPEED AND PROPULSIVE COEFFICIENT
IF(PCEND.EQ.0.) PCEND=.65
IF(PCMXSP.EQ.0.) PCMXSP=.67
IF(JHPDPT.EQ.2) GO TO 21
CALL HPCALC(VSUS,SHP,PCMXSP)
IF(LBP.LT.0.) GO TO 998
GO TO 22

C
      CALC MAX SUSTAINED SPEED GIVEN MAX SUSTAINED SHP
21 VMAX=8.696*((SHP/LBP)*0.2668
23 CALL HPCALC(VMAX,SHPS,PCMXSP)
IF(LBP.LT.0.) GO TO 998
SHP1=SHPS
VMAX1=0.95*VMAX
CALL HPCALC(VMAX1,SHPS,PCMXSP)
IF(LBP.LT.0.) GO TO 998
SHP2=SHPS
DELHP=(SHP1-SHP2)/(VMAX-VMAX1)
IF(DELHP.EQ.0.) GO TO 24
VMAX1=VMAX-(SHP1-SHP)/DELHP
IF(ABS(VMAX1-VMAX).LE.VMAX1*.005) GO TO 24
VMAX=VMAX1
GO TO 23
24 VSUS=VMAX1
22 SHPM=SHP/.8
CALL HPCALC(VEND,SHPE,PCEND)
IF(LBP.LT.0.) GO TO 998
      CALC ELECTRIC LOADS AND SIZE GENERATORS
C
CALL EPLANT
C
CALL MACHLQ
      CALC WEIGHT OF ALL LIQUIDS TO BE CARRIED
C
CALL MBSIZE
      CALC MINIMUM DEPTH AND BEAM OF MACHINERY BOX
C
CALL VOLUME(ERROR)
      CALC VOLUME REQUIRED BY FUNCTIONAL GROUPING
  
```



```

IF(ERROR.GT.0.0) GO TO 888
      CALC WEIGHT REQUIRED BY BSCI GROUPINGS
CALL WEIGHT
IF(ABS(DISPFL-DPTRY).LT.DISTOL) GO TO 38
IF(NDIS.GE.2) GO TO 39
NHALF=1
FACTOR=0.60
GO TO 63
39 FACTOR=(DPTRY-DISPFL-DP1+WT1)/(DPTRY-DP1)
63 DP1=DPTRY
   WT1=DISPFL
   DPTRY=DPTRY-(DPTRY-DISPFL)/FACTOR
   IF (FACTOR.GE.0.) GO TO 10
   IF(DPTRY.LT.0.) GO TO 60
   DPTRY=(.5**NHALF)*DP1
   GO TO 65
60 DPTRY=(2.**NHALF)*DP1
65 NHALF=NHALF+1
10 IF(NDIS.GT.MXDIS) GO TO 995
   NDIS=NDIS+1
   IF(NLEN.GT.0) KGEOM=1
   IF(KGEOM.EQ.0) GO TO 45
   GO TO 37
38 CONTINUE
   NDIS=1
   CALL VRTCG
   IF(ABS(CGFLD-KGTRY).LT.VCGTOL) GO TO 41
   IF(NVCG.GT.MXVCG) GO TO 994
   IF(CGFLD.LT.KGTRY) GO TO 42
43 KGTRY=(CGFLD+KGTRY)/2.
   NVCG=NVCG+1
   IF(NLEN.GT.0) KGEOM=1
   IF(KGEOM.EQ.0) GO TO 45
   GO TO 37
42 IF(R.LT..001) GO TO 43
   EXCKG=KGTRY-CGFLD

```

```

MAIN0217
MAIN0218
MAIN0219
MAIN0220
MAIN0221
MAIN0222
MAIN0223
MAIN0224
MAIN0225
MAIN0226
MAIN0227
MAIN0228
MAIN0229
MAIN0230
MAIN0231
MAIN0232
MAIN0233
MAIN0234
MAIN0235
MAIN0236
MAIN0237
MAIN0238
MAIN0239
MAIN0240
MAIN0241
MAIN0242
MAIN0243
MAIN0244
MAIN0245
MAIN0246
MAIN0247
MAIN0248
MAIN0249
MAIN0250
MAIN0251
MAIN0252

```

C

MAIN0253
MAIN0254
MAIN0255
MAIN0256
MAIN0257
MAIN0258
MAIN0259
MAIN0260
MAIN0261
MAIN0262
MAIN0263
MAIN0264
MAIN0265
MAIN0266
MAIN0267
MAIN0268
MAIN0269
MAIN0270
MAIN0271
MAIN0272
MAIN0273
MAIN0274
MAIN0275
MAIN0276
MAIN0277
MAIN0278
MAIN0279
MAIN0280
MAIN0281
MAIN0282
MAIN0283
MAIN0284
MAIN0285
MAIN0286
MAIN0287
MAIN0288

```
41 CONTINUE
   NVCG=1
   IF(LRD.LE.LBP) GO TO 40
888 IF(NLEN.GT.0) GO TO 499
   PRINT 500,NSHIP
   GO TO 498
499 PRINT 501,NSHIP
501 FORMAT(IH0,10X,'SHIP NUMBER',I4)
498 PRINT 491,LBP,LRD
491 FORMAT(IH0,10X,'LBP=',F6.1,3X,'LRD=',F6.1)
   PRINT 103
103 FORMAT(IH0,'TOO LARGE A VOLUME REQUIRED FOR SOLUTION USING INPUT L
LENGTH, LENGTH BEING INCREASED')
   NLEN=NLEN+1
   LBP=LBP+10.0
   IF(NLEN.GT.10) GO TO 996
   GO TO 20
40 CALL FNCGRP
   CALL SEASPD(AVSP)
   CALL OUTPUT
   GO TO 6
994 PRINT 500,NSHIP
500 FORMAT(IH1,10X,'SHIP NUMBER',I4)
   PRINT 106,VCGTOL,MXVCG
106 FORMAT(IH0,'NO BALANCE BETWEEN ASSUMED AND CALC KG WITHIN',F5.2,
1,' FEET COULD RE MADE IN',F4.0,' ITERATIONS')
   GO TO 1000
995 PRINT 500,NSHIP
   PRINT 105,DISTOL,MXDIS
105 FORMAT(IH0,'NO BALANCE BETWEEN WEIGHT AND DISPLACEMENT WITHIN',
1F5.2,' TONS COULD BE MADE IN',F4.0,' ITERATIONS')
   GO TO 1000
996 PRINT 500,NSHIP
   PRINT 104
104 FORMAT(IH0,'TOO LARGE A VOLUME REQUIRED FOR SOLUTION USING INPUT L
LENGTH, TRY A LONGER SHIP')
```

MAIN0289
MAIN0290
MAIN0291
MAIN0292
MAIN0293
MAIN0294
MAIN0295
MAIN0296
MAIN0297
MAIN0298
MAIN0299
MAIN0300

GO TO 1000
998 PRINT 500,NSHIP
PRINT 101
101 FORMAT(1H0,'LIMITS OF STORED RESISTANCE DATA EXCEEDED')
GO TO 1000
999 PRINT 500,NSHIP
PRINT 100
100 FORMAT(1H0,'VCG IS ABOVE LIMITS OF STORED DATA')
1000 PRINT 102
102 FORMAT(1H0,'PROGRAM PROCEEDING TO NEXT INPUT CASE')
GO TO 6
END

```

SUBROUTINE DATA2 (X,IND,K)
DIMENSION IND(3),COL(72),ICOL(72),X(K)
EQUIVALENCE (COL,ICOL),(BLANK,IBLANK),(ANINE,NINE),(COMMA,KOMMA),
X(PERIOD,IPRIOD),(PLUS,IPLUS),(AMINUS,MINUS),(TEMP,ITEMP),
X(SHIFT,ISHIFT)
IN=2
IOUT=3
IBLANK=1077952576
KOMMA=1799372864
IPRIOD=1262501952
IPLUS=1312833600
MINUS=1614823488
READ 10, (COL(I), I=1,72)
10 FORMAT (72A1)
DO 20 I=1,72
IF(COL(I).NE.BLANK) GO TO 50
20 CONTINUE
IND(I)=1
RETURN
30 READ 10, (COL(I), I=1,72)
DO 40 I=1,72
IF (COL(I).NE.BLANK) GO TO 50
40 CONTINUE
IND(I)=0
RETURN
50 SWCH=0.
IDIM=0
ISUB=0
I=0
KNT=1
IPROD=1
I=I+1
60 IF(ICOL(I).EQ.IBLANK) GO TO 60
75 IF(ICOL(I)+0) 110,110,90
90 IND(I)=2
PRINT 100, (COL(I),I=1,72)

```

```

DAT20001
DAT20002
DAT20003
DAT20004
DAT20005
DAT20006
DAT20007
DAT20008
DAT20009
DAT20010
DAT20011
DAT20012
DAT20013
DAT20014
DAT20015
DAT20016
DAT20017
DAT20018
DAT20019
DAT20020
DAT20021
DAT20022
DAT20023
DAT20024
DAT20025
DAT20026
DAT20027
DAT20028
DAT20029
DAT20030
DAT20031
DAT20032
DAT20033
DAT20034
DAT20035
DAT20036

```

```

100 FORMAT (16X, 16H2ID DATA CARD..., 72A1)
      RETURN
110 IF(ICOL(I).EQ.-264224704) ITEMP=0
      IF(ICOL(I).EQ.-247447488) ITEMP=1
      IF(ICOL(I).EQ.-230670272) ITEMP=2
      IF(ICOL(I).EQ.-213893056) ITEMP=3
      IF(ICOL(I).EQ.-197115840) ITEMP=4
      IF(ICOL(I).EQ.-180338624) ITEMP=5
      IF(ICOL(I).EQ.-163561408) ITEMP=6
      IF(ICOL(I).EQ.-146784192) ITEMP=7
      IF(ICOL(I).EQ.-130006976) ITEMP=8
      IF(ICOL(I).EQ.-113229760) ITEMP=9
      IF(ICOL(I).LT.-264224704) GO TO 90
      IDIM=10*IDIM+ITEMP
120 I=I+1
      IF (I-72) 130,130,90
130 IF(ICOL(I).EQ.IBLANK) GO TO 190
140 IF(ICOL(I).NE.KOMMA) GO TO 75
150 KNT=KNT+1
      IF(KNT-IND(1)) 160,160,90
160 IF (KNT-2) 170,170,180
170 ISUB=IDIM
      IDIM=0
      IPROD=IPROD*IND(KNT)
      GO TO 120
180 ISUB=ISUB+(IDIM-1)*IPROD
      IPROD=IPROD*IND(KNT)
      IDIM=0
      GO TO 120
190 IF (KNT-1) 195,195,200
195 ISUB=IDIM
      GO TO 210
200 IF(KNT-IND(1)) 90,205,90
205 ISUB=ISUB+(IDIM-1)*IPROD
210 I=I+1
      IF (I-72) 230,230,220

```

```

DAT20037
DAT20038
DAT20039
DAT20040
DAT20041
DAT20042
DAT20043
DAT20044
DAT20045
DAT20046
DAT20047
DAT20048
DAT20049
DAT20050
DAT20051
DAT20052
DAT20053
DAT20054
DAT20055
DAT20056
DAT20057
DAT20058
DAT20059
DAT20060
DAT20061
DAT20062
DAT20063
DAT20064
DAT20065
DAT20066
DAT20067
DAT20068
DAT20069
DAT20070
DAT20071
DAT20072

```

```

220 IF(SWCH-0.) 90,90,30
230 IF(ICOL(I).EQ.IBLANK) GO TO 210
240 VAL=0.
    SIN=0.
    PER=0.
    EXPON=0.
    SINE=0.
    PERE=0.
250 IF(ICOL(I)+0) 370,370,260
260 IF(ICOL(I).EQ.IPRIO0) GO TO 350
270 IF(ICOL(I).EQ.IPLUS) GO TO 320
280 IF(ICOL(I).NE.MINUS) GO TO 90
290 IF(VAL-0.) 420,300,420
300 IF(SIN-0.) 90,310,90
310 SIN=-1.
    GO TO 410
320 IF (VAL-0.) 440,330,440
330 IF(SIN-0.) 90,340,90
340 SIN=1.
    GO TO 410
350 IF(PER-0.) 90,360,90
360 PER=1.
    AMAG=10.
    GO TO 410
370 IF(ICOL(I).EQ.-264224704) ITEMP=0
    IF(ICOL(I).EQ.-247447488) ITEMP=1
    IF(ICOL(I).EQ.-230670272) ITEMP=2
    IF(ICOL(I).EQ.-213893056) ITEMP=3
    IF(ICOL(I).EQ.-197115840) ITEMP=4
    IF(ICOL(I).EQ.-180338624) ITEMP=5
    IF(ICOL(I).EQ.-163561408) ITEMP=6
    IF(ICOL(I).EQ.-146784192) ITEMP=7
    IF(ICOL(I).EQ.-130006976) ITEMP=8
    IF(ICOL(I).EQ.-113229760) ITEMP=9
    IF(ICOL(I).LT.-264224704) GO TO 90
    TEMP=ITEMP

```

```

DAT20073
DAT20074
DAT20075
DAT20076
DAT20077
DAT20078
DAT20079
DAT20080
DAT20081
DAT20082
DAT20083
DAT20084
DAT20085
DAT20086
DAT20087
DAT20088
DAT20089
DAT20090
DAT20091
DAT20092
DAT20093
DAT20094
DAT20095
DAT20096
DAT20097
DAT20098
DAT20099
DAT20100
DAT20101
DAT20102
DAT20103
DAT20104
DAT20105
DAT20106
DAT20107
DAT20108

```

DAT20109
 DAT20110
 DAT20111
 DAT20112
 DAT20113
 DAT20114
 DAT20115
 DAT20116
 DAT20117
 DAT20118
 DAT20119
 DAT20120
 DAT20121
 DAT20122
 DAT20123
 DAT20124
 DAT20125
 DAT20126
 DAT20127
 DAT20128
 DAT20129
 DAT20130
 DAT20131
 DAT20132
 DAT20133
 DAT20134
 DAT20135
 DAT20136
 DAT20137
 DAT20138
 DAT20139
 DAT20140
 DAT20141
 DAT20142
 DAT20143
 DAT20144

```

380 IF(PER=0.) 390,390,400
390 VAL=10.*VAL+TEMP
    GO TO 410
400 VAL=VAL+(TEMP/AMAG)
    AMAG=10.*AMAG
410 I=I+1
    IF (I-72) 415,415,550
415 IF(ICOL(I).EQ.IBLANK) GO TO 550
    IF(ICOL(I).NE.IBLANK) GO TO 250
420 IF(SINE=0.) 90,430,90
430 SINE=-1.
    GO TO 530
440 IF(SINE=0.) 90,450,90
450 SINE=1.
    GO TO 530
460 IF(ICOL(I)+0) 500,500,470
470 IF(ICOL(I).NE.IPRID) GO TO 90
480 IF(PER=0.) 90,490,90
490 PERE=1.
    AMAG=10.
    GO TO 530
500 IF(ICOL(I).EQ.-264224704) ITEMP=0
    IF(ICOL(I).EQ.-247447488) ITEMP=1
    IF(ICOL(I).EQ.-230670272) ITEMP=2
    IF(ICOL(I).EQ.-213893056) ITEMP=3
    IF(ICOL(I).EQ.-197115840) ITEMP=4
    IF(ICOL(I).EQ.-180338624) ITEMP=5
    IF(ICOL(I).EQ.-163561408) ITEMP=6
    IF(ICOL(I).EQ.-146784192) ITEMP=7
    IF(ICOL(I).EQ.-130006976) ITEMP=8
    IF(ICOL(I).EQ.-113229760) ITEMP=9
    IF(ICOL(I).LT.-264224704) GO TO 90
    TEMP=ITEMP
    IF(PER=0.) 510,510,520
510 EXPON=10.*EXPON+TEMP
    GO TO 530
  
```

```
520 EXPON=EXPON+(TEMP/AMAG)
    AMAG=10.*AMAG
530 I=I+1
    IF (I-72) 540,540,550
540 IF(ICOL(I).NE.IBLANK) GO TO 460
550 IF(SIN-0.) 570,560,570
560 SIN=1.
570 X(ISUB)=SIN*VAL*10.**(SINE*EXPON)
    ISUB=ISUB+1
    SWCH=1.
    GO TO 210
    END
```

```
DAT20145
DAT20146
DAT20147
DAT20148
DAT20149
DAT20150
DAT20151
DAT20152
DAT20153
DAT20154
DAT20155
DAT20156
```

PAYL0001
 PAYL0002
 PAYL0003
 PAYL0004
 PAYL0005
 PAYL0006
 PAYL0007
 PAYL0008
 PAYL0009
 PAYL0010
 PAYL0011
 PAYL0012
 PAYL0013
 PAYL0014
 PAYL0015
 PAYL0016
 PAYL0017
 PAYL0018
 PAYL0019
 PAYL0020
 PAYL0021
 PAYL0022
 PAYL0023
 PAYL0024
 PAYL0025
 PAYL0026

```

SUBROUTINE SPAYLD
DIMENSION WW(900)
COMMON/DATA/P(7,300),S(2500),Q(100),IT(100)
COMMON/WTMOM/W(900),VM(900),VCG(900),WPAYIN,DCMARG,DISPFL,VWT(400)
C
      CALCULATE WEIGHT OF PAYLOAD ITEMS
      DO 129 J=1,900
129  WW(J)=0.
      DO 130 I=1,100
      IF(Q(I).LT.0.) GO TO 133
      IF(IT(I).EQ.0) GO TO 130
      IF(P(1,IT(I)).EQ.0.) GO TO 130
      WW(P(1,IT(I)))=Q(I)*P(3,IT(I))
      W(P(1,IT(I)))=W(P(1,IT(I)))+WW(P(1,IT(I)))
130  CONTINUE
C
      CALCULATE WEIGHT OF SPECIAL PAYLOAD ITEMS
133  DO 131 K=2300,2499,10
      IF(S(K).EQ.0.) GO TO 131
      WW(S(K))=S(K+2)
      W(S(K))=W(S(K))+WW(S(K))
131  CONTINUE
      WPAYIN=0.0
C
      SUM PAYLOAD WEIGHT INPUT
      DO 132 M=1,900
132  WPAYIN=WPAYIN+W(M)
      RETURN
      END

```

```

SUBROUTINE GEOM
REAL LBP,LBRAT
COMMON/UND/FSCORR,CP,CX,GMBMIN,KGTRY,B,CWP,LBP,R,LBRAT,BHRAT,DPTRY
COMMON/DEPTH/F0,F10,F20,D0,D10,D20,H,DECKHT,LRD,DAVG
DPTRY=DPTRY/1.014
CB=CP*CX
CV=CB/(BHRAT*LBRAT**2.)
LBP=(35.*DPTRY/CV)**(1./3.)
B=LBP/LBRAT
H=B/BHRAT
DPTRY=DPTRY*1.014
RETURN
END

```

```

GEOM0001
GEOM0002
GEOM0003
GEOM0004
GEOM0005
GEOM0006
GEOM0007
GEOM0008
GEOM0009
GEOM0010
GEOM0011
GEOM0012
GEOM0013

```

UWDI0001
 UWDI0002
 UWDI0003
 UWDI0004
 UWDI0005
 UWDI0006
 UWDI0007
 UWDI0008
 UWDI0009
 UWDI0010
 UWDI0011
 UWDI0012
 UWDI0013
 UWDI0014
 UWDI0015
 UWDI0016
 UWDI0017
 UWDI0018
 UWDI0019
 UWDI0020
 UWDI0021
 UWDI0022
 UWDI0023
 UWDI0024
 UWDI0025
 UWDI0026
 UWDI0027
 UWDI0028
 UWDI0029
 UWDI0030
 UWDI0031
 UWDI0032
 UWDI0033
 UWDI0034
 UWDI0035
 UWDI0036

```

SUBROUTINE UWDIM
REAL LBP
COMMON/UND/FSCORR,CP,CX,C5,C4,B1,CWP,LBP,R,LBRAT,BHRAT,DPTRY
COMMON/DEPTH/F0,F10,F20,D0,D10,D20,H,DECKHT,LRD,DAVG
DIMENSION A(5),B(5),C(5)
DPTRY=DPTRY/1.014
CB=CP*CX
CWP=0.425*CB+0.526
CALPH=.0733*CP+0.0026
C1=DPTRY*35./(LBP*CP*CX)
C2=0.833-CP*CX/(3.*CWP)
C3=LBP*CALPH/(DPTRY*35.)
C4=C4+FSCORR
R=KB+BM-KG-FSCORR-GM=C2*H+C3*B**3-C4-C5*B
H=C1/B
DR/DB=-C1*C2/B**2+3*C3*B**2-C5=0 FOR MINIMUM POINT
BMIN=SQRT((C5+SQRT(C5**2+12.*C1*C2*C3))/(6.*C3))
HMIN=C1/BMIN
BTR=BMIN/HMIN
IF(BTR.LT.2..OR.BTR.GT.4.) GO TO 1
R=C2*HMIN+C3*BMIN**3-C4-C5*BMIN
IF(R.LE.0.0) GO TO 2
C4=C4-FSCORR+R
B1=BMIN
H=HMIN
DPTRY=DPTRY*1.014
RETURN
1 HMAX=SQRT(C1/2.005)
BMIN=C1/HMAX
R=C2*HMAX+C3*BMIN**3-C4-C5*BMIN
IF(R.LE.0.0) GO TO 2
C4=C4-FSCORR+R
B1=BMIN
H=HMAX
DPTRY=DPTRY*1.014
RETURN

```

C
 C
 C

UWDI0037
 UWDI0038
 UWDI0039
 UWDI0040
 UWDI0041
 UWDI0042
 UWDI0043
 UWDI0044
 UWDI0045
 UWDI0046
 UWDI0047
 UWDI0048
 UWDI0049
 UWDI0050
 UWDI0051
 UWDI0052
 UWDI0053
 UWDI0054
 UWDI0055
 UWDI0056
 UWDI0057
 UWDI0058
 UWDI0059
 UWDI0060
 UWDI0061
 UWDI0062
 UWDI0063
 UWDI0064
 UWDI0065
 UWDI0066

```

2 HMIN=SQRT(C1/3.995)
  BMAX=C1/HMIN
  R=C2*HMIN+C3*BMAX**3-C4-C5*BMAX
  IF(R.LT.0.0) GO TO 6
  A(1)=1.0
  A(2)=-C4/C2
  A(3)=-C1*C5/C2
  A(4)=0.0
  A(5)=C3/C2*C1**3
  B(1)=1.0
  C(1)=1.0
  Z=HMIN
  H**4-C4/C2*H**3-C1/C2*C5*H**2-C1**3*C3/C2=0
3 DO 4 I=2,5
  B(I)=A(I)+Z*B(I-1)
  C(I)=B(I)+Z*C(I-1)
  ZNEW=Z-B(5)/C(4)
  IF(ABS(ZNEW-Z).LE.0.01*ZNEW) GO TO 5
  Z=ZNEW
  GO TO 3
5 H=ZNEW
  B1=C1/H
  C4=C4-FSCORR
  R=0.
  DPTRY=DPTRY*1.014
  RETURN
6 LBP=-1000.0
  DPTKY=DPTRY*1.014
  RETURN
  END
  
```

HPCLO001
 HPCLO002
 HPCLO003
 HPCLO004
 HPCLO005
 HPCLO006
 HPCLO007
 HPCLO008
 HPCLO009
 HPCLO010
 HPCLO011
 HPCLO012
 HPCLO013
 HPCLO014
 HPCLO015
 HPCLO016
 HPCLO017
 HPCLO018
 HPCLO019
 HPCLO020
 HPCLO021
 HPCLO022
 HPCLO023
 HPCLO024
 HPCLO025
 HPCLO026
 HPCLO027
 HPCLO028
 HPCLO029
 HPCLO030
 HPCLO031
 HPCLO032
 HPCLO033
 HPCLO034
 HPCLO035
 HPCLO036

```

SUBROUTINE HPCALC(VK, SHPS, PC)
  REAL LBP, KGTRY
  INTEGER PPTYP
  COMMON/PROPPW/VSPUS, VEND, DELCF, PPTYP, JHPOPT, PCHXSP, PCEND, ENDUR
  COMMON/UND/FSCORR, CP, CX, GMBMIN, KGTRY, B, CWP, LBP, R, LBRAT, BHRAT, DPTRY
  COMMON/DEPTH/F0, F10, F20, D0, D10, D20, H, DECKHT, LRD, DAVG
  DISPL=DPTRY/1.014
  VOL=DISPL*35.
  BDR=B/H
  RN=VK*LBP*132050.
  CF=.075/(ALOG10(RN)-2.)*2+DELCF
  SLRAT=VK/(SQRT(LBP))
  CV=VOL/(LBP)**3
  IF(BDR.LT.2..OR.BDR.GT.4.) GO TO 1000
  IF(CP.LT..48..OR.CP.GT..7) GO TO 1000
  IF(SLRAT.LT..5..OR.SLRAT.GT.2.) GO TO 1000
  IF(CV.LT..001..OR.CV.GT..006) GO TO 1000
  IF(CV.GT..003..AND.SLRAT.GT.1.3) GO TO 1000
  CALL CRVAL(BDR, CV, CP, SLRAT, CR)
  CT=CF+CR*.001
  S=(1.7*LBP*H+VOL/H)*(.0053*BDR*BDR-.02*BDR+3.*CV+.08*CP+.926)
  A=.00438*1.9905*S
  EHPBH=A*VK**3*CT
  IF(SLRAT.LE.0.85) EHPAPP=1.3*EHPBH
  IF(SLRAT.LE.1.6..AND.SLRAT.GT.0.85) EHPAPP=(1.4587-0.1867*SLRAT)
  1*EHPBH
  IF(SLRAT.LE.1.92..AND.SLRAT.GT.1.6) EHPAPP=(1.310-0.0938*SLRAT)
  1*EHPBH
  IF(SLRAT.GT.1.92) EHPAPP=1.13*EHPBH
  IF(SLRAT.LE.0.70) EHP=1.1*EHPAPP
  IF(SLRAT.LE.0.82..AND.SLRAT.GT.0.70) EHP=(1.205-0.150*SLRAT)*EHPAPP
  IF(SLRAT.LE.1.18..AND.SLRAT.GT.0.82) EHP=(1.3827-0.3667*SLRAT)
  1*EHPAPP
  IF(SLRAT.LE.1.4..AND.SLRAT.GT.1.18) EHP=(1.1109-0.1364*SLRAT)
  1*EHPAPP
  IF(SLRAT.LE.1.78..AND.SLRAT.GT.1.4) EHP=(0.9753-0.0395*SLRAT)
  
```

HPCL0037
HPCL0038
HPCL0039
HPCL0040
HPCL0041
HPCL0042
HPCL0043

```
1*EHPAPP  
IF (SLRAT.GT.1.78) EHP=(0.8645+0.0227*SLRAT)*EHPAPP  
SHPS=EHP/PC  
RETURN  
1000 LBP=-1000.  
RETURN  
END
```

CRVL0001
 CRVL0002
 CRVL0003
 CRVL0004
 CRVL0005
 CRVL0006
 CRVL0007
 CRVL0008
 CRVL0009
 CRVL0010
 CRVL0011
 CRVL0012
 CRVL0013
 CRVL0014
 CRVL0015
 CRVL0016
 CRVL0017
 CRVL0018
 CRVL0019
 CRVL0020
 CRVL0021
 CRVL0022
 CRVL0023
 CRVL0024
 CRVL0025
 CRVL0026
 CRVL0027
 CRVL0028
 CRVL0029
 CRVL0030
 CRVL0031
 CRVL0032
 CRVL0033
 CRVL0034
 CRVL0035
 CRVL0036

```

SUBROUTINE CRVAL(BTR,CV,CP,VL,CR)
COMMON/CRVALS/CR1(1152),CR2(972),CR3(216)
I1(J,K,L,M)=(K-1)*384+(J-1)*192+(L-1)*16+M
I2(J,K,L,M)=(K-1)*324+(J-3)*108+(L-1)*9+M
I3(J,K,L,M)=(K-1)*72+(L-1)*6+M
IF(BTR.GE.3.) K1=2
IF(BTR.LT.3.) K1=1
K2=K1+1
CP1=.68
3 IF(CP-CP1+.0001) 1,2,2
1 CP1=CP1-.02
GO TO 3
2 L1=FIX((CP1-.46)*50.1)
L2=L1+1
CV1=.005
4 IF(CV-CV1+.00001) 5,6,6
5 CV1=CV1-.001
GO TO 4
13 J1=J1-1
CV1=CV1-.001
GO TO 14
6 J1=FIX(CV1*1001.)
IF(J1.EQ.5.AND.VL.GT.1.) GO TO 13
IF(J1.EQ.2.AND.VL.GT.1.3) GO TO 13
14 J2=J1+1
VL1=1.9
7 IF(VL-VL1+.0001) 8,9,9
8 VL1=VL1-.1
GO TO 7
9 M1=FIX((VL1-.4)*10.1)
M2=M1+1
J=J1
INDEX=1
11 IF(J.GE.3) GO TO 10
I=I1(J,K1,L1,M1)
CRA=CR1(I)
  
```

CRVL0037
CRVL0038
CRVL0039
CRVL0040
CRVL0041
CRVL0042
CRVL0043
CRVL0044
CRVL0045
CRVL0046
CRVL0047
CRVL0048
CRVL0049
CRVL0050
CRVL0051
CRVL0052
CRVL0053
CRVL0054
CRVL0055
CRVL0056
CRVL0057
CRVL0058
CRVL0059
CRVL0060
CRVL0061
CRVL0062
CRVL0063
CRVL0064
CRVL0065
CRVL0066
CRVL0067
CRVL0068
CRVL0069
CRVL0070
CRVL0071
CRVL0072

I=I1(J,K1,L1,M2)
CR8=CR1(I)
I=I1(J,K1,L2,M1)
CRC=CR1(I)
I=I1(J,K1,L2,M2)
CRD=CR1(I)
I=I1(J,K2,L1,M1)
CRE=CR1(I)
I=I1(J,K2,L1,M2)
CRF=CR1(I)
I=I1(J,K2,L2,M1)
CRG=CR1(I)
I=I1(J,K2,L2,M2)
CRH=CR1(I)
GO TO 50
10 IF(J.EQ.6) GO TO 12
I=I2(J,K1,L1,M1)
CRA=CR2(I)
I=I2(J,K1,L1,M2)
CRB=CR2(I)
I=I2(J,K1,L2,M1)
CRC=CR2(I)
I=I2(J,K1,L2,M2)
CRD=CR2(I)
I=I2(J,K2,L1,M1)
CRE=CR2(I)
I=I2(J,K2,L1,M2)
CRF=CR2(I)
I=I2(J,K2,L2,M1)
CRG=CR2(I)
I=I2(J,K2,L2,M2)
CRH=CR2(I)
GO TO 50
12 I=I3(J,K1,L1,M1)
CRA=CR3(I)
I=I3(J,K1,L1,M2)

CRVL0073
CRVL0074
CRVL0075
CRVL0076
CRVL0077
CRVL0078
CRVL0079
CRVL0080
CRVL0081
CRVL0082
CRVL0083
CRVL0084
CRVL0085
CRVL0086
CRVL0087
CRVL0088
CRVL0089
CRVL0090
CRVL0091
CRVL0092
CRVL0093
CRVL0094
CRVL0095
CRVL0096
CRVL0097
CRVL0098
CRVL0099
CRVL0100
CRVL0101
CRVL0102
CRVL0103
CRVL0104
CRVL0105

```
CRB=CR3(I)
I=I3(J,K1,L2,M1)
CRC=CR3(I)
I=I3(J,K1,L2,M2)
CRD=CR3(I)
I=I3(J,K2,L1,M1)
CRE=CR3(I)
I=I3(J,K2,L1,M2)
CRF=CR3(I)
I=I3(J,K2,L2,M1)
CRG=CR3(I)
I=I3(J,K2,L2,M2)
CRH=CR3(I)
50 V=(VL-VL1)*10.
C=(CP-CPI)*50.
BTR1=FLOAT((K1-1))*75+2.25
B=(BTR-BTR1)/.75
C1=(CRB-CRA)*V+CRA
C2=(CRD-CRC)*V+CRC
C3=(CRF-CRE)*V+CRE
C4=(CRH-CRG)*V+CRG
C5=(C2-C1)*C+C1
C6=(C4-C3)*C+C3
C7=(C6-C5)*B+C5
IF(INDEX.GE.2) GO TO 51
A=C7
J=J2
INDEX=2
GO TO 11
51 D=C7
CR=(D-A)*(CV-CV1)*1000.+A
RETURN
END
```

EPLT0001
 EPLT0002
 EPLT0003
 EPLT0004
 EPLT0005
 EPLT0006
 EPLT0007
 EPLT0008
 EPLT0009
 EPLT0010
 EPLT0011
 EPLT0012
 EPLT0013
 EPLT0014
 EPLT0015
 EPLT0016
 EPLT0017
 EPLT0018
 EPLT0019
 EPLT0020
 EPLT0021
 EPLT0022
 EPLT0023
 EPLT0024
 EPLT0025
 EPLT0026
 EPLT0027
 EPLT0028
 EPLT0029
 EPLT0030
 EPLT0031
 EPLT0032
 EPLT0033
 EPLT0034
 EPLT0035
 EPLT0036

```

SUBROUTINE EPLANT
REAL LBP,LBRAT
INTEGER PPTYP,SSETYP,EMETYP
COMMON/DATA/P(7,300),S(2500),Q(100),IT(100)
COMMON/WTMOM/W(900),VM(900),VCG(900),WPAYIN,DCMARG,DISPFL,VWT(400)
COMMON/UND/FSCORR,CP,CX,GMBMIN,KGTRY,B,CWP,LBP,R,LBRAT,BHRAT,DPTRY
COMMON/DEPTH/F0,F10,F20,DO,D10,D20,H,DECKHT,LRD,DAVG
COMMON/ELPLT/ECR(11),EBT(11),EAV(11),ELMARG,MXFCWK,KW24AV,HTTYP
COMMON/GENSZ/KWSSER,KWEMER,KWINST,SSETYP,EMETYP,NLSD,NMSD,NHSD,
  INGTG,NSTG,KWPRD,KWPRGT,KWPRSG,NGFCLD,NGAVG,NSSG,NEMG,KELEC
COMMON/PROPPW/VSPUS,VEND,DELCF,PPTYP,JHPOPT,PCMXSP,PCEND,ENDUR
FLDISP=DPTRY
A=1.0
IF(PPTYP.EQ.4) A=4.0
E=1.0
IF(PPTYP.EQ.4) E=2.0
      CALC CRUISE KW LOADS
ECR(1)=(0.00173*(FLDISP*VSUS)-64.62)*A
ECR(2)=(0.0517*FLDISP+19.27)*E
ECR(3)=2.0
ECR(4)=6.9
WGP4=0.0
      CALC WTGP 4 MINUS WTGP 451
DO 2 I=400,499
2 WGP4=WGP4+W(I)
WGP4=WGP4-W(451)-W(486)-W(496)
ECR(5)=0.2041*WGP4+172.71
ECR(6)=25.6
ECR(7)=0.0169*FLDISP+59.38
ECR(8)=0.1649*FLDISP-344.33
IF(HTTYP.EQ.2.0) ECR(8)=0.1320*FLDISP+438.96
ECR(9)=110.0
ECR(10)=ELMARG*(ECR(1)+ECR(2)+ECR(3)+ECR(4)+ECR(5)+ECR(6)+ECR(7)+
1ECR(8)+ECR(9))
DO 900 K=2200,2209
IF(S(K).EQ.0.0) GO TO 900

```

C

C

```

ECR(K-2199)=S(K)
900 CONTINUE
ECR(11)=0.0
DO 4 I=1,10
4 ECR(11)=ECR(11)+ECR(I)
IF(S(2210).GT.0.0) ECR(11)=S(2210)
C      CALC BATTLE KW LOADS
EBT(1)=(0.00209*(FLDISP*VSUS)-99.19)*A
EBT(2)=(0.0746*FLDISP-14.21)*E
EBT(3)=1.5
EBT(4)=1.2
EBT(5)=0.3613*WGP4+174.52
C      CALC WTGP 7
WTGP7=0.0
DO 6 J=700,799
6 WTGP7=WTGP7+W(J)
WTGP7=WTGP7-W(774)-W(784)-W(794)
EBT(6)=1.670*WTGP7-63.79
EBT(7)=0.00794*FLDISP+64.70
EBT(8)=0.0382*FLDISP+193.40
EBT(9)=214.6
EBT(10)=ELMARG*(EBT(1)+EBT(2)+EBT(3)+EBT(4)+EBT(5)+EBT(6)+EBT(7)+
1EBT(8)+EBT(9))
DO 901 M=2211,2220
IF(S(M).EQ.0.0) GO TO 901
EBT(M-2210)=S(M)
901 CONTINUE
EBT(11)=0.0
DO 8 I=1,10
8 EBT(11)=EBT(11)+EBT(I)
IF(S(2221).GT.0.0) EBT(11)=S(2221)
C      DETERMINE MAX FUNCTIONAL LOAD
MXFCKW=MAX1(ECR(11),EBT(11))
C      CALC 24 HR KW AVERAGE LOAD
EAV(1)=(0.00115*(FLDISP*VSUS)+7.63)*A
EAV(2)=(0.0705*FLDISP-80.54)*E

```

```

EPLT0037
EPLT0038
EPLT0039
EPLT0040
EPLT0041
EPLT0042
EPLT0043
EPLT0044
EPLT0045
EPLT0046
EPLT0047
EPLT0048
EPLT0049
EPLT0050
EPLT0051
EPLT0052
EPLT0053
EPLT0054
EPLT0055
EPLT0056
EPLT0057
EPLT0058
EPLT0059
EPLT0060
EPLT0061
EPLT0062
EPLT0063
EPLT0064
EPLT0065
EPLT0066
EPLT0067
EPLT0068
EPLT0069
EPLT0070
EPLT0071
EPLT0072

```

EPLT0073
 EPLT0074
 EPLT0075
 EPLT0076
 EPLT0077
 EPLT0078
 EPLT0079
 EPLT0080
 EPLT0081
 EPLT0082
 EPLT0083
 EPLT0084
 EPLT0085
 EPLT0086
 EPLT0087
 EPLT0088
 EPLT0089
 EPLT0090
 EPLT0091
 EPLT0092
 EPLT0093
 EPLT0094
 EPLT0095
 EPLT0096
 EPLT0097
 EPLT0098
 EPLT0099
 EPLT0100
 EPLT0101
 EPLT0102
 EPLT0103
 EPLT0104
 EPLT0105
 EPLT0106
 EPLT0107
 EPLT0108

```

EAV(3)=0.3
EAV(4)=5.4
EAV(5)=0.3322*WGP4+143.17
EAV(6)=12.1
EAV(7)=0.00462*FLDISP+123.03
EAV(8)=0.1021*FLDISP-114.19
IF(HTTYP.EQ.2.0) ECR(8)=0.1252*FLDISP+343.10
EAV(9)=99.4
EAV(10)=ELMARG*(EAV(1)+EAV(2)+EAV(3)+EAV(4)+EAV(5)+EAV(6)+EAV(7)+
1EAV(8)+EAV(9))
DO 902 N=2222,2231
IF(S(N).EQ.0.0) GO TO 902
EAV(N-2221)=S(N)
902 CONTINUE
EAV(11)=0.0
DO 10 I=1,10
10 EAV(11)=EAV(11)+EAV(I)
IF(S(2232).GT.0.0) EAV(11)=S(2232)
KW24AV=EAV(11)
IF(KELEC.EQ.0) NLSD=NMSD+NHSD+NGTG=NSTG=0
NOW SIZE ELECTRIC PLANT
IF(KELEC.EQ.1) GO TO 800
GO TO 801
800 IF(NSTG.EQ.0) GO TO 802
STEAM PLANT, SO STEAM GEN PLUS DIE OR G.T. EMER
C
KWSSER=NSTG*KWPRSG
KWEMER=(NLSD+NMSD+NHSD)*KWPRD+NGTG*KWPRGT
KWINST=KWSSER+KWEMER
NGFCLD=MXFCWKW/KWPRSG+1
NGAVG=KW24AV/KWPRSG+1
NSSG=NSTG
NEMG=NLSD+NMSD+NHSD+NGTG
GO TO 850
C
802 KWSSER=(NLSD+NMSD+NHSD)*KWPRD+NGTG*KWPRGT
KWEMER=0
DIESEL, GAS TURB OR COGAS PLANT

```

EPLT0109
EPLT0110
EPLT0111
EPLT0112
EPLT0113
EPLT0114
EPLT0115
EPLT0116
EPLT0117
EPLT0118
EPLT0119
EPLT0120
EPLT0121
EPLT0122
EPLT0123
EPLT0124
EPLT0125
EPLT0126
EPLT0127
EPLT0128
EPLT0129
EPLT0130
EPLT0131
EPLT0132
EPLT0133
EPLT0134
EPLT0135
EPLT0136
EPLT0137
EPLT0138
EPLT0139
EPLT0140
EPLT0141
EPLT0142
EPLT0143
EPLT0144

```
KWINST=KWSSE+KWEMER
KWGEN=MAX0(KWPRD,KWPRGT)
NGFCLD=MXFCKW/KWGEN+1
NGAVG=KW24AV/KWGEN+1
NSSG=NLSO+NMSD+NHSO+NGTG
NEMG=0
GO TO 850
C      GENERATOR NUMBER AND SIZE NOT GIVEN SO MUST CALC
      801 IF(MXFCKW.GE.1000) GO TO 870
         KWGEN=MXFCKW/2
         KWGEN=500
         IF(MXFCKW/2.LT.300) KWGEN=300
         NGFCLD=2
         NGAVG=KW24AV/KWGEN+1
         NSSG=3
         NEMG=2
         KWEMER=400
         KWSSER=KWGEN*NSSG
         GO TO 860
      870 NGFCLD=3
         NSSG=4
         NEMG=2
         KWEMER=600
         IF(MXFCKW.GE.1500) GO TO 871
         KWGEN=500
         KWSSE=2000
         KWINST=2600
         NGAVG=KW24AV/KWGEN+1
         GO TO 860
      871 IF(MXFCKW.GE.2250) GO TO 872
         KWGEN=750
         KWSSE=3000
         KWINST=3600
         NGAVG=KW24AV/KWGEN+1
         GO TO 860
      872 KWEMER=1000
```

EPLT0145
EPLT0146
EPLT0147
EPLT0148
EPLT0149
EPLT0150
EPLT0151
EPLT0152
EPLT0153
EPLT0154
EPLT0155
EPLT0156
EPLT0157
EPLT0158
EPLT0159
EPLT0160
EPLT0161
EPLT0162
EPLT0163
EPLT0164
EPLT0165
EPLT0166
EPLT0167
EPLT0168
EPLT0169
EPLT0170
EPLT0171
EPLT0172
EPLT0173
EPLT0174
EPLT0175
EPLT0176
EPLT0177
EPLT0178
EPLT0179
EPLT0180

IF(MXFCKW.GE.3000) GO TO 873
KWGEN=1000
KWSSER=4000
KWINST=5000
NGAVG=KW24AV/KWGEN+1
GO TO 860
873 KWEMER=1500
IF(MXFCKW.GE.4500) GO TO 874
KWGEN=1500
KWSSER=6000
KWINST=7500
NGAVG=KW24AV/KWGEN+1
GO TO 860
874 IF(MXFCKW.GE.6000) GO TO 875
KWGEN=2000
KWSSER=8000
KWINST=9500
NGAVG=KW24AV/KWGEN+1
GO TO 860
875 KWEMER=2000
IF(MXFCKW.GE.7500) GO TO 876
KWGEN=2500
KWSSER=10000
KWINST=12000
NGAVG=KW24AV/KWGEN+1
GO TO 860
876 KWGEN=2500
NSSG=MXFCKW/KWGEN+2
KWSSER=NSSG*KWGEN
KWINST=KWSSER+KWEMER
NGFCLD=NSSG-1
NGAVG=KW24AV/KWGEN+1
GENERATORS SIZED ABOVE SO NOW DETERMINE TYPE
C 860 NGTG=NLSO=NMSD=NHTG=NSTG=0
KWPRD=KWPRGT=KWPRSG=0
IF(SSETYP.LE.1) GO TO 50

```

NEMG=0
KWEMER=0
KWINST=KWSSER
GO TO (50,51,51,52,53,54),SSETYP
50 NSTG=NSSG
KWPRSG=KWGEN
GO TO (60,60,61,62,63),EMETYP
61 NLSD=NEMG
KWPRD=KWEMER/NEMG
GO TO 850
62 NMSD=NEMG
KWPRD=KWEMER/NEMG
GO TO 850
63 NHSD=NEMG
KWPRD=KWEMER/NEMG
GO TO 850
60 NGTG=NEMG
KWPRGT=KWEMER/NEMG
GO TO 850
51 NGTG=NSSG
KWPRGT=KWGEN
GO TO 850
52 NLSD=NSSG
KWPRD=KWGEN
GO TO 850
53 NMSD=NSSG
KWPRD=KWGEN
GO TO 850
54 NHSD=NSSG
KWPRD=KWGEN
850 CONTINUE
RETURN
END

```

```

EPLT0181
EPLT0182
EPLT0183
EPLT0184
EPLT0185
EPLT0186
EPLT0187
EPLT0188
EPLT0189
EPLT0190
EPLT0191
EPLT0192
EPLT0193
EPLT0194
EPLT0195
EPLT0196
EPLT0197
EPLT0198
EPLT0199
EPLT0200
EPLT0201
EPLT0202
EPLT0203
EPLT0204
EPLT0205
EPLT0206
EPLT0207
EPLT0208
EPLT0209
EPLT0210
EPLT0211
EPLT0212
EPLT0213

```

MALQ0001
MALQ0002
MALQ0003
MALQ0004
MALQ0005
MALQ0006
MALQ0007
MALQ0008
MALQ0009
MALQ0010
MALQ0011
MALQ0012
MALQ0013
MALQ0014
MALQ0015
MALQ0016
MALQ0017
MALQ0018
MALQ0019
MALQ0020
MALQ0021
MALQ0022
MALQ0023
MALQ0024
MALQ0025
MALQ0026
MALQ0027
MALQ0028
MALQ0029
MALQ0030
MALQ0031
MALQ0032
MALQ0033
MALQ0034
MALQ0035
MALQ0036

```

SUBROUTINE MACHLQ
COMMON/DATA/P(7,300),S(2500),Q(100),IT(100)
INTEGER PPTYP,SSETYP,EMETYP
COMMON/WTMOM/W(900),VM(900),VCG(900),WPAYIN,DCMARG,DISPFL,VWT(400)
COMMON/ELPLT/ECR(11),EBT(11),EAV(11),ELMARG,MXCKW,KW24AV,HTTYP
COMMON/GENSZ/KWSSER,KWEMER,KWINST,SSETYP,EMETYP,NLSD,NMSD,NHSD,
1NGTG,NSTG,KWPRD,KWPRGT,KWPRSG,NGFCLD,NGAVG,NSSG,NEMG,KELEC
COMMON/PROPPW/VSUS,VEND,DELCF,PPTYP,JHPOPT,PCMXSP,PCEND,ENDUR
COMMON/MNMACH/SHP,NB,NR,NE,NSHFT,PRPTYP,SHFTYP,RPM,DPRDP,SHPE
COMMON/PEOPLE/NACC,NOFF,NCPO,NCREW,NFLAG,NTRP,NPASS,DUR,NACSC
C          POTABLE WATER
W(812)=0.053*NACC*1.214
C          RESERVE FEED WATER
GO TO (2,3,3,4,1,1,1,2),PPTYP
1 W(813)=0.0
GO TO 10
2 W(813)=0.2022*SHP**0.530
GO TO 10
3 W(813)=0.000583*SHP**1.057
GO TO 10
4 W(813)=0.00362*SHP**0.9466
10 CONTINUE
C          LUBE OIL SHIP
GO TO (5,6,6,7,9,9,8,9),PPTYP
5 W(814)=.0000388*SHP+3.08
GO TO 20
6 W(814)=0.00286*SHP**0.7649
GO TO 20
7 W(814)=5.51E-6*SHP**1.387
GO TO 20
8 W(814)=0.00398*SHP
GO TO 20
9 W(814)=4.366*SHP**0.1122
20 CONTINUE
C          FUEL OIL (NON-DIESEL)
GO TO (32,32,32,31,33,33,34,35),PPTYP

```



```

31 W(816)=0.0
GO TO 30
32 AVEDPW=1.1*SHPE
FRSTM=0.5882*AVEDPW+1303.92
W(816)=(ENDUR*FRSTM)/(VEND*2240.0)*1.18
GO TO 30
33 AVEDPW=1.1*SHPE
IF(NSHFT.EQ.2) GO TO 40
NEEND=2
IF(AVEDPW.LE.SHP/NE) NEEND=1
GO TO 41
40 NEEND=4
IF(AVEDPW.LE.2.*SHP/NE) NEEND=2
41 EDPWE=AVEDPW/NEEND
SFCFP=-.0000101*SHP/NE+0.717
IF(PPTY.EQ.6) SFCFP=-.0000101*SHP/NE+0.627
SFCaed=SFCFP*(1.2298*(1.-EDPWE/(SHP/NE)))*1.6384+1.0)
WFPROP=ENDUR*AVEDPW*SFCaed/(VEND*2240.0)*1.18
GO TO 50
34 WFPROP=0.0
GO TO 50
35 FRCGAS=2589.0+0.288*SHP
WFPROP=ENDUR*FRCGAS/(VEND*2240.0)*1.18
50 GO TO (30,61,61,62,62,62),SSETYP
61 AVEDPW=KW24AV/(.8*.746)
AEDPWG=AVEDPW/NGAVG
SFCFP=-.0000101*(KWPRGT/(.8*.746))+0.717
IF(SSETYP.EQ.3) SFCFP=-.0000101*(KWPRGT/(.8*.746))+0.627
SFCaed=SFCFP*(1.2298*(1.-AEDPWG/(KWPRGT/(.8*.746))))*1.6384+1.0)
WFELEC=ENDUR*AVEDPW*SFCaed/(VEND*2240.0)*1.05
GO TO 60
62 WFELEC=0.0
60 FRAUXB=1.044*NAACC
WFAUXB=ENDUR*FRAUXB/(VEND*2240.0)*1.05
W(816)=WFPROP+WFELEC+WFAUXB
30 CONTINUE
MALQ0037
MALQ0038
MALQ0039
MALQ0040
MALQ0041
MALQ0042
MALQ0043
MALQ0044
MALQ0045
MALQ0046
MALQ0047
MALQ0048
MALQ0049
MALQ0050
MALQ0051
MALQ0052
MALQ0053
MALQ0054
MALQ0055
MALQ0056
MALQ0057
MALQ0058
MALQ0059
MALQ0060
MALQ0061
MALQ0062
MALQ0063
MALQ0064
MALQ0065
MALQ0066
MALQ0067
MALQ0068
MALQ0069
MALQ0070
MALQ0071
MALQ0072

```

C

```

      DIESEL OIL
71  GO TO (71,71,71,71,72,72,73,72),PPTY
    W(817)=0.1432*KWEMER-5.60
72  GO TO 70
    WFPROP=0.0
73  GO TO 75
    AVEDPW=1.1*SHPE
    IF(NSHFT.EQ.2) GO TO 76
    NEEND=2
    IF(AVEDPW.LE.SHP/NE) NEEND=1
    GO TO 77
76  NEEND=4
    IF(AVEDPW.LE.2.*SHP/NE) NEEND=2
77  EDPWPE=AVEDPW/NEEND
    RATFP=EDPWPE/(SHP/NE)
    SFCAED=0.274*EXP(-5.166*RATFP)+0.359
    WFPROP=ENDUR*AVEDPW*SFCAED/(VEND*2240.0)*1.18
75  GO TO (81,81,81,82,82),SSETYP
81  WFELEC=0.0
    GO TO 85
82  FRDIEG=1.8845*(KW24AV/NGAVG)**0.8273
    WFELEC=ENDUR*FRDIEG*NGAVG/(VEND*2240.0)*1.05
85  W(817)=WFPROP+WFELEC
70  CONTINUE
    DO 100 I=1012,1022
    IF(S(I).GT.0.) W(I-200)=S(I)
100  CONTINUE
    RETURN
    END
```

MALQ0073
MALQ0074
MALQ0075
MALQ0076
MALQ0077
MALQ0078
MALQ0079
MALQ0080
MALQ0081
MALQ0082
MALQ0083
MALQ0084
MALQ0085
MALQ0086
MALQ0087
MALQ0088
MALQ0089
MALQ0090
MALQ0091
MALQ0092
MALQ0093
MALQ0094
MALQ0095
MALQ0096
MALQ0097
MALQ0098
MALQ0099
MALQ0100
MALQ0101

MBSZ0001
MBSZ0002
MBSZ0003
MBSZ0004
MBSZ0005
MBSZ0006
MBSZ0007
MBSZ0008
MBSZ0009
MBSZ0010
MBSZ0011
MBSZ0012
MBSZ0013
MBSZ0014
MBSZ0015
MBSZ0016
MBSZ0017
MBSZ0018
MBSZ0019
MBSZ0020
MBSZ0021
MBSZ0022
MBSZ0023
MBSZ0024

```

SUBROUTINE MBSIZE
REAL LBP,KGTRY,LENMB
INTEGER PPTYP
COMMON/MBDIM/DEPMB,LENMB,BEAMMB
COMMON/MNMACH/SHP,NB,NR,NE,NSHFT,PRPTY,SHFTYP,RPM,DPROP,SHPE
COMMON/PROPPW/VSUS,VEND,DELCF,PPTY,JHPOPT,PCMXSP,PCEND,ENDUR
COMMON/UND/FSCORR,CP,CX,GMBSMIN,KGTRY,B,CWP,LBP,R,LBRAT,BHRAT,DPTRY
COMMON/DEPTH/FO,F10,F20,D0,D10,D20,H,DECKHT,LRD,DAVG
IF(DEPMB.GT.0.0) GO TO 100
      DETERMINE TYPE PROP PLANT AND FIND MIN DEPTH
GO TO (1,1,1,1,2,2,2,2),PPTYP
1  CVK=.2*B-6.0
   HCOR=-10.0*CX+9.0
   HABCVK=0.00025*SHP/NSHFT+20.5
   IF(NB/NSHFT.GT.1) HABCVK=.000125*SHP/NSHFT+20.0
   DEPMB=CVK+HCOR+HABCVK
   GO TO 100
2  HCOR=-10.0*CX+9.0
   CVK=.2*B-6.0
   HABCVK=19.0
   IF(NSHFT.GT.1) HABCVK=21.5
   DEPMB=CVK+HCOR+HABCVK
100 RETURN
END

```

C

VOLM0001
VOLM0002
VOLM0003
VOLM0004
VOLM0005
VOLM0006
VOLM0007
VOLM0008
VOLM0009
VOLM0010
VOLM0011
VOLM0012
VOLM0013
VOLM0014
VOLM0015
VOLM0016
VOLM0017
VOLM0018
VOLM0019
VOLM0020
VOLM0021
VOLM0022
VOLM0023
VOLM0024
VOLM0025
VOLM0026
VOLM0027
VOLM0028
VOLM0029
VOLM0030
VOLM0031
VOLM0032
VOLM0033
VOLM0034
VOLM0035
VOLM0036

```

SUBROUTINE VOLUME(ERROR)
REAL LBP,KGTRY,LRD,LRD1,LENMB,LMB
INTEGER PPTYP,SSETYP,EMETYP
COMMON/MISC/FINST,HULMAT,SSMAT,PASTYP
COMMON/DATA/P(7,300),S(2500),Q(100),IT(100)
COMMON/WTDM/W(900),VM(900),VCG(900),WPAYIN,DCMARG,DISPFL,VWT(400)
COMMON/VOLUM/V(400),VOLTOT,VOLSST,VOLHUL,VOLMB,FNDEN(400)
COMMON/GENSZ/KWSSER,KWEMER,KWINST,SSETYP,EMETYP,NLSD,NMSD,NHSD,
INGTG,NSTG,KWPRD,KWPRGT,KWPRSG,NGFCLO,NGAVG,NSSG,NEMG,KELEC
COMMON/UND/FSCORR,CP,CX,GMBMIN,KGTRY,B,CWP,LBP,R,LBRAT,BHRAT,DPTRY
COMMON/PROPPW/VSUS,VEND,DELCF,PPTYP,JHPOPT,PCMXSP,PCEND,ENDUR
COMMON/MNMACH/SHP,NB,NR,NE,NSHFT,PRPTY,SHFTYP,RPM,DPROP,SHPE
COMMON/MBDIM/DEPMB,LENMB,BEAMMB
COMMON/PEOPLE/NACC,NOFF,NCPO,NCREW,NFLAG,NTRP,NPASS,DUR,NACSC
COMMON/DEPTH/F0,F10,F20,D0,D10,D20,H,DECKHT,LRD,DAVG
DIMENSION VVH(400),VVS(400),VVH(400),VVSS(400)
ERROR=0.0
FLDISP=DPTRY
KNDEX=0
DECKHT=0.
LRD=0.
LRD1=0.
NSHEER=0
      DEVELOP ACCEPTABLE SHEER LINE
13 CALL SHEER(DEPMB,F0,F10,F20,D0,D10,D20,LBP,H,DECKHT,NSHEER)
IF(NSHEER.EQ.1) GO TO 1000
AREA=LBP/6.*(F0+F20+4*F10)
FAVG=AREA/LBP
DAVG=FAVG+H
F7=-.018828*(DAVG/H)**2+.18098*DAVG/H+.714599
      USING FLARE FACTOR ABOVE CALC TOTAL HULL VOLUME
HVAW=LBP#B#CWP#FAVG#F7
HVBW=LBP#B#H#CP#CX
THV=HVAW+HVBW
DO 17 I=1,400
17 V(I)=0.0

```

C

C

VOLM0037
 VOLM0038
 VOLM0039
 VOLM0040
 VOLM0041
 VOLM0042
 VOLM0043
 VOLM0044
 VOLM0045
 VOLM0046
 VOLM0047
 VOLM0048
 VOLM0049
 VOLM0050
 VOLM0051
 VOLM0052
 VOLM0053
 VOLM0054
 VOLM0055
 VOLM0056
 VOLM0057
 VOLM0058
 VOLM0059
 VOLM0060
 VOLM0061
 VOLM0062
 VOLM0063
 VOLM0064
 VOLM0065
 VOLM0066
 VOLM0067
 VOLM0068
 VOLM0069
 VOLM0070
 VOLM0071
 VOLM0072

```

C      ESTIMATE MACHBX LENGTH
      IF(LENMB.GT.0.0) GO TO 34
      GO TO (21,21,21,22,23,23,24,23),PPTYP
21  V(321)=30851.+1.472*SHp+7.735*KWINST
      GO TO 30
22  V(321)=0.2685*(SHp+KWINST/(.8*.746))**1.225
      GO TO 30
23  V(321)=0.8346*(SHp+KWINST/(.8*.746))**1.084
      GO TO 30
24  V(321)=893.21*SHp**0.4955
30  IF(S(2121).GT.0.0) V(321)=S(2121)
      AM=8*H*CX+B*F10
      CPM=0.95
      IF(S(2299).GT.0.0) CPM=S(2299)
      LMB=V(321)/(AM*CPM)
      VOLMB=V(321)
      GO TO 14
34  CPM=0.95
      IF(S(2299).GT.0.0) CPM=S(2299)
      V(321)=LENMB*CPM*(BEAMMB*H*CX+B*(DEPMB-H))
      LMB=LENMB
      VOLMB=V(321)
      MIN TANKAGE VOLUME IS CALC
14  T=(-.9037115+.2139727*D10-1.38263E-2*D10**2+4.008058E-4*D10**3
      1-5.489481E-6*D10**4+2.892153E-8*D10**5)*CP/.58*CX/.814*(1.11*LMB/
      2LBP+.667)
      AHVOM=THV-V(321)
      ATVOM=T*AHVOM
      DETERMINE ALL VOLUMES REQUIRED
      CALCULATE VOLUME OF PAYLOAD INPUT
      DECKHT=9.0
      IF(S(2274).GT.0.) DECKHT=S(2274)
      DO 40 I=1,400
40  VVH(I)=VVSS(I)=VVHH(I)=VVSS(I)=0
      DO 41 I=1,100
      IF(Q(I).LT.0.) GO TO 44
  
```

VOLM0073
 VOLM0074
 VOLM0075
 VOLM0076
 VOLM0077
 VOLM0078
 VOLM0079
 VOLM0080
 VOLM0081
 VOLM0082
 VOLM0083
 VOLM0084
 VOLM0085
 VOLM0086
 VOLM0087
 VOLM0088
 VOLM0089
 VOLM0090
 VOLM0091
 VOLM0092
 VOLM0093
 VOLM0094
 VOLM0095
 VOLM0096
 VOLM0097
 VOLM0098
 VOLM0099
 VOLM0100
 VOLM0101
 VOLM0102
 VOLM0103
 VOLM0104
 VOLM0105
 VOLM0106
 VOLM0107
 VOLM0108

```

IF(IT(I).EQ.0) GO TO 41
IF(P(2,IT(I)).EQ.0.) GO TO 41
VVSS(P(2,IT(I)))=Q(I)*P(6,IT(I))*DECKHT
VVS(P(2,IT(I)))=VVS(P(2,IT(I)))+VVSS(P(2,IT(I)))
VVHH(P(2,IT(I)))=Q(I)*P(7,IT(I))*DECKHT
VVH(P(2,IT(I)))=VVH(P(2,IT(I)))+VVHH(P(2,IT(I)))
V(P(2,IT(I)))=VVS(P(2,IT(I)))+VVH(P(2,IT(I)))
41 CONTINUE
44 DO 42 K=2301,2499,10
IF(S(K).EQ.0.) GO TO 42
VVSS(S(K))=S(K+4)*DECKHT
VVS(S(K))=VVS(S(K))+VVSS(S(K))
VVHH(S(K))=S(K+5)*DECKHT
VVH(S(K))=VVH(S(K))+VVHH(S(K))
V(S(K))=VVS(S(K))+VVH(S(K))
42 CONTINUE
C
CALC VOLUME OF NON INPUT FUNCTIONS
V(116)=0.332*FLDISP+1437.+V(116)
IF(NTRP.GT.0) V(140)=572.36*NTRP**0.8906
IF(NFLAG.GT.0) V(160)=572.36*NFLAG**0.8906
IF(NPASS.GT.0) V(170)=572.36*NPASS**0.8906
DO 43 J=2250,2273
IF(S(J).EQ.0.0) S(J)=1.0
43 CONTINUE
V(211)=(777.77*NOFF-3906.56)*S(2250)
IF(NOFF.GT.0) V(212)=(526.83*NOFF**0.6533)*S(2251)
IF(NOFF.GT.0) V(213)=(128.92*NOFF**0.8878)*S(2252)
V(214)=(255.15*NCPO+488.10)*S(2253)
V(215)=(89.91*NCPO+584.75)*S(2254)
V(216)=(53.78*NCPO+588.04)*S(2255)
V(217)=(129.45*NCREW+9828.35)*S(2256)
V(218)=(23.12*NCREW+4429.66)*S(2257)
V(219)=(26.31*NCREW+573.84)*S(2258)
IF(NACC.GT.0) V(221)=(3.33*NACC**1.088)*S(2259)
IF(NACC.GT.0) V(222)=(107.22*NACC**0.7933)*S(2260)
V(223)=(18.33*NACC-2124.47)*S(2261)
  
```

C

VOLM0109
VOLM0110
VOLM0111
VOLM0112
VOLM0113
VOLM0114
VOLM0115
VOLM0116
VOLM0117
VOLM0118
VOLM0119
VOLM0120
VOLM0121
VOLM0122
VOLM0123
VOLM0124
VOLM0125
VOLM0126
VOLM0127
VOLM0128
VOLM0129
VOLM0130
VOLM0131
VOLM0132
VOLM0133
VOLM0134
VOLM0135
VOLM0136
VOLM0137
VOLM0138
VOLM0139
VOLM0140
VOLM0141
VOLM0142
VOLM0143
VOLM0144

V(224)=(16.30*NACC+1316.03)*S(2262)
V(225)=(2.91*NACC+1473.42)*S(2263)
IF(NACC*DUR.GT.0.) V(231)=(0.8642*(NACC*DUR)**0.965)*S(2264)
V(232)=(17.22*NACC-623.12)*S(2265)
V(233)=(7.172*NACC+793.50)*S(2266)
V(311)=(0.00749*LBP**2.258)*S(2267)
V(312)=0.417*FLDISP+1062.74
V(313)=(0.8889*FLDISP+541.68)*S(2268)
GO TO (51,51,51,52,54,54,53,54),PPTYP
51 V(322)=0.4547*SHP**0.9134
GO TO 50
52 V(322)=2000.0
GO TO 50
53 V(322)=8.32*SHP**0.6667
GO TO 50
54 V(322)=.00951*(SHP+KWINST/(.8*.746))**1.355
50 CONTINUE
IF(NSHFT.EQ.1) GO TO 60
V(323)=2.10E-5*LBP**3.034
GO TO 61
60 GO TO (62,62,62,62,63,63,63,63),PPTYP
62 V(323)=15.90*LBP-3688.67
GO TO 61
63 V(323)=0.0
61 CONTINUE
V(324)=0.0183*(FLDISP*VSUS)+2248.70
V(325)=(2.092*FLDISP-1516.62)*S(2269)
V(331)=0.6413*LBP**1.432
V(341)=(0.8036*FLDISP-200.37)*S(2270)
V(342)=(0.1943*FLDISP+331.42)*S(2271)
V(343)=(0.0291*FLDISP**1.284)*S(2272)
IF(W(816).GT.0.) V(351)=105.85*W(816)**0.8532
IF(PPTYP.EQ.4) V(351)=0.0
IF(W(813).GT.0.) V(352)=0.5324*W(813)**1.9287
V(353)=39.0*W(814)
IF(W(817).GT.0.) V(354)=27.93*W(817)**1.0798

VOLM0145
VOLM0146
VOLM0147
VOLM0148
VOLM0149
VOLM0150
VOLM0151
VOLM0152
VOLM0153
VOLM0154
VOLM0155
VOLM0156
VOLM0157
VOLM0158
VOLM0159
VOLM0160
VOLM0161
VOLM0162
VOLM0163
VOLM0164
VOLM0165
VOLM0166
VOLM0167
VOLM0168
VOLM0169
VOLM0170
VOLM0171
VOLM0172
VOLM0173
VOLM0174
VOLM0175
VOLM0176
VOLM0177
VOLM0178
VOLM0179
VOLM0180

```

V(355)=40.0*W(820)
V(356)=0.5353*NACC*DUR+4422.87
V(361)=40.0*W(822)
V(362)=0.450*FLDISP-145.90
V(363)=2.38E-5*FLDISP**2.314
V(370)=0.0
DO 90 I=1900,2199
IF(S(I).GT.0.0) V(I-1800)=S(I)
90 CONTINUE
IF(V(121)+V(122)+V(123)+V(124)+V(125)+V(126)+V(128).GT.0.)
1V(127)=0.3577*(V(121)+V(122)+V(123)+V(124)+V(125)+V(126)+V(128))
2*0.8958
IF(S(1927).GT.0.0) V(127)=S(1927)
TANKAGE VOLUME REQUIRED
VTKREQ=V(134)+V(233)+V(351)+V(352)+V(353)+V(354)+V(355)+V(361)
1+V(362)+V(363)+V(364)+V(365)
RTAV=0.0
IF(VTKREQ.GT.ATVOM) RTAV=VTKREQ-ATVOM
TANKVL=ATVOM+RTAV
IF(ATVOM.GT.VTKREQ) V(363)=V(363)+ATVOM-VTKREQ
AVAV=AHVOM-TANKVL
AVAV=ACT AVAILABLE HULL ARRG VOL (THV-V(321))-TANKVL
VOLTOT=0.0
DO 91 J=100,400
VOLTOT=VOLTOT+V(J)
91 CONTINUE
VOLTOT=VOLTOT-V(370)
V(370)=(0.130*VOLTOT**0.9233)*S(2273)
IF(PASTYP.EQ.2.0) V(370)=(90.90*VOLTOT**0.4932)*S(2273)
IF(S(2170).GT.0.0) V(370)=S(2170)
NOW GET TOTAL INTERNAL VOLUME REQUIRED
VOLTOT=VOLTOT+V(370)
C CALC VOLUME REQUIRED IN HULL AND IN SUPERSTRUCTURE
C HAVE ALREADY TAKEN OUT MACH BOX & TANKAGE VOLUME FROM HULL
C NOW CALC REQUIRED SUPERSTRUCTURE VOLUME
VOMPSS=0.

```

VOLM0181
 VOLM0182
 VOLM0183
 VOLM0184
 VOLM0185
 VOLM0186
 VOLM0187
 VOLM0188
 VOLM0189
 VOLM0190
 VOLM0191
 VOLM0192
 VOLM0193
 VOLM0194
 VOLM0195
 VOLM0196
 VOLM0197
 VOLM0198
 VOLM0199
 VOLM0200
 VOLM0201
 VOLM0202
 VOLM0203
 VOLM0204
 VOLM0205
 VOLM0206
 VOLM0207
 VOLM0208
 VOLM0209
 VOLM0210
 VOLM0211
 VOLM0212
 VOLM0213
 VOLM0214
 VOLM0215
 VOLM0216

```

DO 200 I=1,400
VOMPSS=VOMPSS+VVS(I)
200 CONTINUE
  RSSV=VOMPSS+V(160)+V(311)*.7+V(322)*.8+.25*V(325)+V(332)+V(357)+
  1V(390)+.2*V(370)
  DHV=.00163*LBP**3
  IF(RSSV.GT.DHV) GO TO 1000
  TAAV=DHV+AVAV
  TRAV=VOLTOT-TANKVL-V(321)
  IF(TRAV.GT.TAAV) GO TO 10
  DHSV=.0008*LBP**3
  DHAMIN=AMAX1(DHSV,RSSV)
  TAAV=DHAMIN+AVAV
  IF(TRAV.GT.TAAV) GO TO 11
  IF(DHSV.GT.RSSV) V(390)=V(390)+TAAV-AMAX1(TRAV,RSSV+AVAV)
  IF(RSSV.GT.DHSV) V(380)=V(380)+TAAV-TRAV
  DHSV=DHAMIN
12 DHV=DHSV
  ENCVOL=DHV+THV
  VOL SST=DHV
  VOLHUL=THV
  VOLTOT=ENCVOL
  RETURN
11 DHSV=TRAV-AVAV
  GO TO 12
C
10 RHAV=TRAV-DHV
  RDAV=RHAV-AVAV
  X1=(RDAV/DECKHT)/(B*LBP)
  IF(X1.GT..7) GO TO 1
  IF(X1.GT..2) GO TO 2
  LRD=-3.22*X1*X1+2.031*X1-.0184
  GO TO 3
1 LRD=.463*X1*X1+.446*X1+.22
  GO TO 3
2 LRD=X1+.059

```

VOLM0217
VOLM0218
VOLM0219
VOLM0220
VOLM0221
VOLM0222
VOLM0223
VOLM0224
VOLM0225
VOLM0226
VOLM0227
VOLM0228
VOLM0229
VOLM0230
VOLM0231
VOLM0232
VOLM0233
VOLM0234
VOLM0235
VOLM0236
VOLM0237
VOLM0238
VOLM0239
VOLM0240
VOLM0241
VOLM0242
VOLM0243
VOLM0244
VOLM0245
VOLM0246

```

3 LRD=LRD*LBP
  IF(ABS(LRD-LRD1).LT..05*LBP) GO TO 15
  IF(KNDEX.GT.20) GO TO 1000
  KNDEX=KNDEX+1
  LRD1=LRD
  GO TO 13

C      CHECK TO SEE IF RAISED DECK LENGTH IS BETWEEN LIMITS

15 C1=.4*LBP
   C2=.6*LBP
   AVAV=RHAV
   IF(LRD.LT.C1.OR.LRD.GT.C2) GO TO 4
   AVAV=AVAV+(C2-LRD)*B*DECKHT
   RDAV=RDAV+(C2-LRD)*B*DECKHT
   IF(DHV-RSSV.GT.(C2-LRD)*B*DECKHT) GO TO 5
   DHV=RSSV
   V(380)=V(380)+(C2-LRD)*B*DECKHT-(DHV-RSSV)
   GO TO 6

5 DHV=DHV-(C2-LRD)*B*DECKHT
6 CONTINUE
  LRD=C2

C      DETERMINE CORRECTED VALUES OF VOLUME.

4 THV=THV+RDAV
  VOLHUL=THV
  ENCVOL=DHV+THV
  VOLTOT=ENCVOL
  VOLSST=DHV
  RETURN
1000 ERROR=1.0
      RETURN
      END

```

```

SUBROUTINE SHEER(DMB,F0,F10,F20,D0,D10,D20,LEN,H,DECKHT,NSHEER)
REAL LEN
KOUNT=0
D10=DMB
IF(D10.LT.LEN/16.) D10=LEN/16.
F0=1.011827*(100.*H/LEN)-.000636215*LEN+2.780649
F0=LEN*F0/100.
F0=F0-DECKHT
D0=F0+H
F20=.01*LEN*(2.125+.00125*LEN)
D20=F20+H
7 S0=D0-D10
R0=S0/LEN
IF(R0.LT..01) GO TO 1
IF(R0.GT..03) GO TO 2
6 S20=D20-D10
R20=S20/LEN
IF(KOUNT.GT.20) GO TO 8
KOUNT=KOUNT+1
IF(R20.LT..001) GO TO 3
IF(R20.GT..0075) GO TO 4
GO TO 5
1 S0=.01*LEN
D0=S0+D10
GO TO 6
2 S0=.03*LEN
D10=D0-S0
GO TO 6
3 S20=.001*LEN
D20=D10+S20
GO TO 5
4 S20=.0075*LEN
D10=D20-S20
GO TO 7
5 F0=D0-H
F20=D20-H

```

```

SHER0001
SHER0002
SHER0003
SHER0004
SHER0005
SHER0006
SHER0007
SHER0008
SHER0009
SHER0010
SHER0011
SHER0012
SHER0013
SHER0014
SHER0015
SHER0016
SHER0017
SHER0018
SHER0019
SHER0020
SHER0021
SHER0022
SHER0023
SHER0024
SHER0025
SHER0026
SHER0027
SHER0028
SHER0029
SHER0030
SHER0031
SHER0032
SHER0033
SHER0034
SHER0035
SHER0036

```

F10=D10-H
RETURN
8 NSHEER=1
RETURN
END

SHER0037
SHER0038
SHER0039
SHER0040
SHER0041

WGHT0001
 WGHT0002
 WGHT0003
 WGHT0004
 WGHT0005
 WGHT0006
 WGHT0007
 WGHT0008
 WGHT0009
 WGHT0010
 WGHT0011
 WGHT0012
 WGHT0013
 WGHT0014
 WGHT0015
 WGHT0016
 WGHT0017
 WGHT0018
 WGHT0019
 WGHT0020
 WGHT0021
 WGHT0022
 WGHT0023
 WGHT0024
 WGHT0025
 WGHT0026
 WGHT0027
 WGHT0028
 WGHT0029
 WGHT0030
 WGHT0031
 WGHT0032
 WGHT0033
 WGHT0034
 WGHT0035
 WGHT0036

SUBROUTINE WEIGHT
 REAL LBP,KGTRY
 INTEGER PPTYP,SSETYP,EMETYP
 COMMON/DATA/P(7,300),S(2500),Q(100),IT(100)
 COMMON/WTMON/W(900),VM(900),VCG(900),WPAYIN,DCMARG,DISPFL,VWT(400)
 COMMON/VOLUM/V(400),VOLTOT,VOLSST,VOLHUL,VOLMB,FNDEN(400)
 COMMON/ELPLT/ECR(11),EBT(11),EAV(11),ELMARG,MXFCWK,KW24AV,HTTY
 COMMON/GENSZ/KWSSER,KWEMER,KWINST,SSETYP,EMETYP,NLSD,NMSD,NHSD,
 1NGTS,NSTG,KWPRD,KWPRGT,KWPRSG,NGFCLD,NGAVG,NSSG,NEMG,KELEC
 COMMON/UND/FSCORR,CP,CX,GMBMIN,KGTRY,B,CWP,LBP,R,LBRAT,BHRAT,DPTRY
 COMMON/DEPTH/F0,F10,F20,D0,D10,D20,H,DECKHT,LRD,DAVG
 COMMON/PROPPW/VUS,VEND,DELCP,PPTY,JPPOPT,PCMXSP,PCEND,ENDUR
 COMMON/MNMACH/SHP,NB,NR,NE,NSHFT,PRPTY,SHFTYP,RPN,DPROP,SHPE
 COMMON/PEOPLE/NAAC,NOFF,NCPO,NCREW,NFLAG,NTRP,NPASS,DUR,NACSC
 COMMON/MISC/FINST,HULMAT,SSMAT,PASTYP
 COMMON/WTGRPS/WTGP1,WTGP2,WTGP3,WTGP4,WTGP5,WTGP6,WTGP7,VRLOAD,
 1DISPLS,WTMARG,WBHS,WSS,WDHS,WARM,WFFL,WFG4,WFG5,VOLSHIP,WTSHIP
 CALC HULL STRUCTURE WEIGHTS --GROUP 1
 SET HULL MATERIAL
 C=1.0
 IF (HULMAT.EQ.2.0) C=0.55
 FLDISP=DPTRY
 W(100)=(0.0677*FLDISP+25.26)*C
 W(101)=(0.0532*FLDISP-55.38)*C+.3*W(794)
 W(102)=0.0
 IF (FLDISP.GT.4600.) W(102)=(.0120*FLDISP+9.27)*C
 W(103)=(.00581*FLDISP**1.159)*C
 W(107)=(.0694*FLDISP-62.51)*C
 W(111)=(.00199*VOLSST-16.44+.2*W(794)
 IF (SSMAT.EQ.2.0) W(111)=(.00778*VOLSST**.820+.2*W(794)
 GO TO (2,1,6,4,5,3,5),PPTY
 1 W(112)=(.00101*SHP/(NB*NSHFT)-3.51)*NB*NSHFT*C
 GO TO 10
 2 W(112)=(0.5428*SHP**0.3348)*C
 GO TO 10
 3 W(112)=(.00204*SHP)*C

WGH T0037
 WGH T0038
 WGH T0039
 WGH T0040
 WGH T0041
 WGH T0042
 WGH T0043
 WGH T0044
 WGH T0045
 WGH T0046
 WGH T0047
 WGH T0048
 WGH T0049
 WGH T0050
 WGH T0051
 WGH T0052
 WGH T0053
 WGH T0054
 WGH T0055
 WGH T0056
 WGH T0057
 WGH T0058
 WGH T0059
 WGH T0060
 WGH T0061
 WGH T0062
 WGH T0063
 WGH T0064
 WGH T0065
 WGH T0066
 WGH T0067
 WGH T0068
 WGH T0069
 WGH T0070
 WGH T0071
 WGH T0072

```

GO TO 10
4 W(112) = (.000818*SHP/(NR*NSHFT)+40.65) *NR*NSHFT*C
GO TO 10
5 W(112) = (.000239*SHP/(NE*NSHFT)+16.18) *NE*NSHFT*C
GO TO 10
6 W(112) = .000714*SHP*C
10 CONTINUE
W(113) = (.000189*VOLHUL-11.68) *C+.3*W(794)
W(114) = (.000285*VOLHUL+22.83) *C
IF(PPTYP.EQ.4) W(114) = (.000658*VOLHUL-115.89) *C
W(115) = 5.27E-5*VOLTOT-4.47+.2*W(794)
W(119) = (7.08E-5*VOLTOT+0.94) *C
W(120) = 8.42E-8*VOLMB**1.53
IF(PPTYP.GE.5) W(120) = 3.03E-8*VOLMB**1.56
W(122) = 0.0
IF(FLDISP.GE.7600.) W(122) = .00342*FLDISP-18.51
W(123) = 3.83E-5*VOLTOT-1.89
W(125) = .000278*FLDISP+3.62
W(150) = (.000527*VOLTOT**8.314) *C
WTGP1 = 0.0
DO 20 I=300,351
IF(S(I).GT.0.) W(I-200) = S(I)
20 CONTINUE
DO 21 J=100,151
WTGP1 = WTGP1+W(J)
21 CONTINUE
C
CALC PROPULSION HEIGHTS --GROUPE 2
GO TO (31,32,33,34,35,36,37),PPTYP
31 W(200) = .00288*SHP+21.92
W(201) = .00175*SHP+13.25
W(202) = .000766*SHP+2.98
W(204) = 1.05E-4*SHP+6.50
W(205) = .000181*SHP+3.18
W(206) = 4.0*NSHFT
W(207) = .000586*SHP-5.68
W(208) = .000564*SHP+7.48
  
```

WGH T0073
 WGH T0074
 WGH T0075
 WGH T0076
 WGH T0077
 WGH T0078
 WGH T0079
 WGH T0080
 WGH T0081
 WGH T0082
 WGH T0083
 WGH T0084
 WGH T0085
 WGH T0086
 WGH T0087
 WGH T0088
 WGH T0089
 WGH T0090
 WGH T0091
 WGH T0092
 WGH T0093
 WGH T0094
 WGH T0095
 WGH T0096
 WGH T0097
 WGH T0098
 WGH T0099
 WGH T0100
 WGH T0101
 WGH T0102
 WGH T0103
 WGH T0104
 WGH T0105
 WGH T0106
 WGH T0107
 WGH T0108

W(209) = .000192*(SHP+KWINST/ (.8*.746)) +4.02
 W(210) = .00882*W(816) +3.25
 W(211) = .000156*SHP+4.82
 W(250) =5.0
 IF(NSHFT.GT.1) W(250)=10.0
 W(251) =.000668*SHP+12.14
 GO TO 40
 32 W(200) =.00234*SHP+48.09
 W(201) =.00143*SHP+17.92
 W(202) =.000457*SHP+2.57
 W(204) =.000119*SHP+12.22
 W(205) =.000136*SHP+14.14
 W(206) =4.0*NSHFT
 W(207) =.000544*SHP-1.70
 W(208) =.000610*SHP+10.42
 W(209) =.000192*(SHP+KWINST/ (.8*.746)) +4.02
 W(210) =.00882*W(816) +3.25
 W(211) =.000156*SHP+4.82
 W(250) =5.0
 IF(NSHFT.GT.1) W(250)=10.0
 W(251) =.000668*SHP+12.14
 GO TO 40
 33 W(200) =.00234*SHP-14.0
 W(201) =.00143*SHP+17.92
 W(202) =.000457*SHP+2.57
 W(204) =.000119*SHP+10.14
 W(205) =.000136*SHP+6.54
 W(206) =4.0*NSHFT
 W(207) =.000544*SHP-1.70
 W(208) =.000610*SHP+10.42
 W(209) =.000192*(SHP+KWINST/ (.8*.746)) +4.02
 W(210) =.00882*W(816) +3.25
 W(211) =.000156*SHP+4.82
 W(250) =5.0
 IF(NSHFT.GT.1) W(250)=10.0
 W(251) =.000668*SHP+12.14

WGH T0109
 WGH T0110
 WGH T0111
 WGH T0112
 WGH T0113
 WGH T0114
 WGH T0115
 WGH T0116
 WGH T0117
 WGH T0118
 WGH T0119
 WGH T0120
 WGH T0121
 WGH T0122
 WGH T0123
 WGH T0124
 WGH T0125
 WGH T0126
 WGH T0127
 WGH T0128
 WGH T0129
 WGH T0130
 WGH T0131
 WGH T0132
 WGH T0133
 WGH T0134
 WGH T0135
 WGH T0136
 WGH T0137
 WGH T0138
 WGH T0139
 WGH T0140
 WGH T0141
 WGH T0142
 WGH T0143
 WGH T0144

```

GO TO 40
34 W(200) = .000183*SHP**1.456
   W(201) = .000761*SHP**1.119
   W(202) = .00923*SHP**1.7935
   W(204) = 0.0
   W(205) = 0.0
   W(206) = 4.0*NSHPT
   W(207) = 33.52*SHP**1.0392
   W(208) = 2.592*SHP**1.3105
   W(209) = 1.32E-8*(SHP+KWINST/ (.8*.746))**1.8642
   W(210) = 0.0
   W(211) = .0443*SHP**1.560
   W(250) = 45.0
   W(251) = .0972*(W(200)+W(201)+W(202)+W(207)+W(208)+W(209)+W(211))
1-69.57
GO TO 40
35 W(200) = 0.0
   W(201) = .00283*SHP+2.68
   W(202) = 0.0
   W(204) = .000196*SHP
   IF (SSETYP.LT.4.AND.SSETYP.GT.1) W(204) = .000503*(SHP+KWINST/ (.8*
1.746))
   W(205) = .00140*(SHP+KWINST/ (.8*.746))
   IF (SSETYP.GT.3) W(205) = .000317*SHP
   W(206) = 5.25E-5*SHP+3.90
   W(207) = 0.0
   W(208) = 0.0
   W(209) = 0.0
   IF (SSETYP.GT.3) W(209) = .000890*KWINST
   W(210) = .00882*W(816)+3.25
   W(211) = 3.10E-7*SHP**1.641
   W(250) = 5.0
   IF (NSHPT.GT.1) W(250) = 10.0
   W(251) = 1.152*(W(209)+W(210)+W(211)) - 10.10
GO TO 40
36 W(200) = 0.0

```

W(201) = .0124*SHP+5.25
 W(202) = 0.0
 W(204) = 0.0
 W(205) = .00209*SHP
 W(206) = .00144*SHP
 W(207) = 0.0
 W(208) = 0.0
 W(209) = .00111*(SHP+KWINST/ (.8*.746))
 W(210) = .00882*W(817) + 3.25
 W(211) = .00193*SHP
 W(250) = 5.0
 IF(NSHFT.GT.1) W(250) = 10.0
 W(251) = .618*(W(209) + W(210) + W(211))
 GO TO 40
 37 W(200) = .00883*SHP
 W(201) = .00247*SHP
 W(202) = .00533*SHP
 W(204) = .00267*SHP
 W(205) = .00140*(SHP+KWINST/ (.8*.746))
 IF(SSETYP.GT.3) W(205) = .000317*SHP
 W(206) = .0005*SHP
 W(207) = 8.33E-5*SHP
 W(208) = 1.833E-4*SHP
 W(209) = .0003*SHP
 W(210) = .00882*W(816) + 3.25
 W(211) = .00267*SHP
 W(250) = 5.0
 IF(NSHFT.GT.1) W(250) = 10.0
 W(251) = .000633*SHP
 40 CONTINUE

CALC WEIGHT OF SHAFTING, BEARINGS & PROPELLERS

F=0.20
 IF(PPTYP.LE.4) F=0.36
 IF(DPROP.GT.0.) GO TO 38
 DPROP=2.603*H**0.629
 IF(NSHFT.GT.1) DPROP=4.281*H**0.4283

C

WGH T0181
 WGH T0182
 WGH T0183
 WGH T0184
 WGH T0185
 WGH T0186
 WGH T0187
 WGH T0188
 WGH T0189
 WGH T0190
 WGH T0191
 WGH T0192
 WGH T0193
 WGH T0194
 WGH T0195
 WGH T0196
 WGH T0197
 WGH T0198
 WGH T0199
 WGH T0200
 WGH T0201
 WGH T0202
 WGH T0203
 WGH T0204
 WGH T0205
 WGH T0206
 WGH T0207
 WGH T0208
 WGH T0209
 WGH T0210
 WGH T0211
 WGH T0212
 WGH T0213
 WGH T0214
 WGH T0215
 WGH T0216

```

38 IF (RPM.GT.0.) GO TO 39
   RPM=96.12*VSUS/DPROP+52.15
39 IF (SHFTYP.EQ.2.) GO TO 41
   IF (PRPTYP.EQ.1.) GO TO 42
   WSHAFT=F*LBP*NSHFT*(1.+5*NSHFT)*(0.134*(SHP/(NSHFT*RPM))**(2./3.
1) )**.9497
   GO TO 45
42 WSHAFT=F*LBP*NSHFT*(.0134*(SHP/(NSHFT*RPM))**(2./3.))**.9497
   GO TO 45
41 WSHAFT=F*LBP*NSHFT*(.0275*(SHP/(NSHFT*RPM))**(2./3.))**.8768
45 CONTINUE
   WPROP=(.00146*DPROP**3.279)*NSHFT
   IF (PRPTYP.EQ.2.) WPROP=(.00314*DPROP**3.128)*NSHFT
   WBRGS=.15*(WSHAFT+WPROP)
   W(203)=WSHAFT+WPROP+WBRGS
   WTGP2=0.0
   DO 50 I=400,451
   IF (S(I).GT.0.) W(I-200)=S(I)
50 CONTINUE
   DO 51 J=200,251
   WTGP2=WTGP2+W(J)
51 CONTINUE
   CALC ELECTRIC PLANT WEIGHTS --GROUP 3
   W(300)=NLSD*(.0424*KWPRD+.44)+NMSD*(.0240*KWPRD+.05)+NHSD*(.0137*
1KWPRD+.32)+NGTG*(.00424*KWPRGT+16.4)+NSTG*(.0167*KWPRSG-1.63)
   W(301)=.0030*KWINST+2.61
   W(302)=2.15E-8*VOLTOT**1.623
   IF (VOLTOT.GE.400000.) W(302)=.000170*VOLTOT-48.83
   W(303)=3.67E-5*VOLTOT-0.73
   W(350)=.000348*KWINST+1.96
   WTGP3=0.0
   DO 52 I=500,551
   IF (S(I).GT.0.) W(I-200)=S(I)
52 CONTINUE
   DO 53 J=300,351
   WTGP3=WTGP3+W(J)
  
```

WGHT0217
 WGHT0218
 WGHT0219
 WGHT0220
 WGHT0221
 WGHT0222
 WGHT0223
 WGHT0224
 WGHT0225
 WGHT0226
 WGHT0227
 WGHT0228
 WGHT0229
 WGHT0230
 WGHT0231
 WGHT0232
 WGHT0233
 WGHT0234
 WGHT0235
 WGHT0236
 WGHT0237
 WGHT0238
 WGHT0239
 WGHT0240
 WGHT0241
 WGHT0242
 WGHT0243
 WGHT0244
 WGHT0245
 WGHT0246
 WGHT0247
 WGHT0248
 WGHT0249
 WGHT0250
 WGHT0251
 WGHT0252

```

53 CONTINUE
      C
      CALC COMMUNICATION AND CONTROL WEIGHTS --GROUP 4
      W(400) = .000350*V(311)+1.62
      W(401) = 5.08E-5*VOLTOT-2.90
      W(403) = .00333*FLDISP+.12
      W(406) = W(486)+W(496)
      W(407) = 0.0
      W(410) = 2.0
      WGP4 = 0.0
      WTGP4 = 0.0
      DO 54 I=600,699
      IF(S(I).GT.0.) W(I-200)=S(I)
54 CONTINUE
      DO 55 J=400,415
      WGP4=WGP4+W(J)
55 CONTINUE
      W(450) = .0317*WGP4+.82
      IF(S(650).GT.0.) W(450)=S(650)
      DO 56 K=400,451
      WTGP4=WTGP4+W(K)
56 CONTINUE
      C
      CALC AUXILIARY SYSTEMS WEIGHTS --GROUP 5
      W(500) = .00011*VOLTOT+.76
      IF(HTYP.EQ.2.) W(500) = 7.72E-8*VOLTOT**1.443
      W(501) = 7.28E-5*VOLTOT+4.57
      W(502) = 3.46E-5*VOLTOT+4.96
      W(503) = .0205*NAACC+3.66
      W(504) = .000728*FLDISP-1.98+W(594)
      W(505) = .00107*(V(213)+V(216)+V(219))- .96
      W(506) = 4.71E-5*VOLTOT+6.63
      W(507) = .000619*VOLTOT** .7224
      W(508) = 2.43E-5*VOLHUL+2.15
      W(509) = .00170*V(233)+3.18
      W(510) = .00756*LBP-.75
      GO TO (58,58,58,57,58,58,59,58),PPTYP
57 W(511) = 0.0
  
```

WGHT0253
WGHT0254
WGHT0255
WGHT0256
WGHT0257
WGHT0258
WGHT0259
WGHT0260
WGHT0261
WGHT0262
WGHT0263
WGHT0264
WGHT0265
WGHT0266
WGHT0267
WGHT0268
WGHT0269
WGHT0270
WGHT0271
WGHT0272
WGHT0273
WGHT0274
WGHT0275
WGHT0276
WGHT0277
WGHT0278
WGHT0279
WGHT0280
WGHT0281
WGHT0282
WGHT0283
WGHT0284
WGHT0285
WGHT0286
WGHT0287
WGHT0288

```
GO TO 60
58 W(511) = .0276*W(816) +4.50
GO TO 60
59 W(511) = .0276*W(817) +4.50
60 CONTINUE
GO TO (61,61,62,62,62,62,62,62),PPTYP
61 W(512) = .00323*W(816) +1.01
GO TO 63
62 W(512) =0.0
63 CONTINUE
GO TO (64,64,66,64,67,67,65,67),PPTYP
64 W(513) =9.59E-5*V(321) -4.50
GO TO 68
65 W(513) =.00132*SHP
GO TO 68
66 W(513) =.000426*SHP
GO TO 68
67 W(513) =.000274*SHP+11.78
68 CONTINUE
W(514) =.000012*VOLTOT
IF(HTYP.EQ.2.) W(514) =0.0
IF(PPTYP.LE.4) W(514) =.000667*SHP**1.046
W(515) =0.0
W(516) =0.0
IF(PPTYP.EQ.4) W(516) =20.0
GO TO (71,71,71,71,72,73,73,73,73),PPTYP
71 W(517) =9.44E-5*V(321) -.86
GO TO 70
72 W(517) =.0783*NACC**.8847
GO TO 70
73 W(517) =.0172*NACC+2.37
70 CONTINUE
W(518) =6.81E-5*FLDISP*VSUS+3.89
W(519) =.000194*FLDISP*VSUS-.08
W(520) =.00860*FLDISP-2.49
W(521) =9.14E-6*VOLTOT+.38
```

W(527)=0.0
 IF(FINST.EQ.2.) W(527)=.00731*FLDISP-1.20
 W(550)=3.5
 W(551)=4.17E-5*VOLTOT-4.93
 WTGP5=0.0
 DO 74 I=700,799
 IF(S(I).GT.0.) W(I-200)=S(I)
 74 CONTINUE
 DO 75 J=500,551
 WTGP5=WTGP5+W(J)
 75 CONTINUE
 C
 CALC OUTFIT AND FURNISHINGS WEIGHTS --GROUP 6
 W(600)=.00230*FLDISP+3.61
 W(601)=.0971*NACC-1.27
 W(602)=1.0
 W(603)=.0000403*VOLTOT+6.70
 IF(PPTYP.EQ.4) W(603)=27.35*FLDISP** .0826
 W(604)=.0000321*VOLTOT+3.50
 W(605)=.0000641*VOLTOT+4.26
 W(606)=.0000408*VOLTOT-5.61
 W(607)=(.0000717*VOLHUL+10.56)/C
 W(608)=.0000712*VOLTOT-2.50
 W(609)=.00113*V(224)-.19
 W(610)=.00211*(V(341)+V(342)+V(343))-3.25
 W(611)=.0152*NACC+7.37
 W(612)=.000271*(V(211)+V(212)+V(213)+V(214)+V(215)+V(216)+V(217))+
 1V(218)+V(219))+3.09
 W(613)=.000921*(V(221)+V(313))+1.51
 IF(NFLAG.GT.0) W(613)=.000505*(V(221)+V(313)+V(160))+3.54
 W(614)=.000265*V(223)+.58
 W(615)=.404*W(703)
 WGP6=0.0
 WTGP6=0.0
 DO 76 I=800,899
 IF(S(I).GT.0.) W(I-200)=S(I)
 76 CONTINUE

W(527)=0.0
 IF(FINST.EQ.2.) W(527)=.00731*FLDISP-1.20
 W(550)=3.5
 W(551)=4.17E-5*VOLTOT-4.93
 WTGP5=0.0
 DO 74 I=700,799
 IF(S(I).GT.0.) W(I-200)=S(I)
 74 CONTINUE
 DO 75 J=500,551
 WTGP5=WTGP5+W(J)
 75 CONTINUE
 C
 CALC OUTFIT AND FURNISHINGS WEIGHTS --GROUP 6
 W(600)=.00230*FLDISP+3.61
 W(601)=.0971*NACC-1.27
 W(602)=1.0
 W(603)=.0000403*VOLTOT+6.70
 IF(PPTYP.EQ.4) W(603)=27.35*FLDISP** .0826
 W(604)=.0000321*VOLTOT+3.50
 W(605)=.0000641*VOLTOT+4.26
 W(606)=.0000408*VOLTOT-5.61
 W(607)=(.0000717*VOLHUL+10.56)/C
 W(608)=.0000712*VOLTOT-2.50
 W(609)=.00113*V(224)-.19
 W(610)=.00211*(V(341)+V(342)+V(343))-3.25
 W(611)=.0152*NACC+7.37
 W(612)=.000271*(V(211)+V(212)+V(213)+V(214)+V(215)+V(216)+V(217))+
 1V(218)+V(219))+3.09
 W(613)=.000921*(V(221)+V(313))+1.51
 IF(NFLAG.GT.0) W(613)=.000505*(V(221)+V(313)+V(160))+3.54
 W(614)=.000265*V(223)+.58
 W(615)=.404*W(703)
 WGP6=0.0
 WTGP6=0.0
 DO 76 I=800,899
 IF(S(I).GT.0.) W(I-200)=S(I)
 76 CONTINUE

WGHT0325
 WGHT0326
 WGHT0327
 WGHT0328
 WGHT0329
 WGHT0330
 WGHT0331
 WGHT0332
 WGHT0333
 WGHT0334
 WGHT0335
 WGHT0336
 WGHT0337
 WGHT0338
 WGHT0339
 WGHT0340
 WGHT0341
 WGHT0342
 WGHT0343
 WGHT0344
 WGHT0345
 WGHT0346
 WGHT0347
 WGHT0348
 WGHT0349
 WGHT0350
 WGHT0351
 WGHT0352
 WGHT0353
 WGHT0354
 WGHT0355
 WGHT0356
 WGHT0357
 WGHT0358
 WGHT0359
 WGHT0360

```

DO 77 J=600,615
  WGP6=WGP6+W(J)
77 CONTINUE
  WGP6=WGP6+W(651)
  W(650)=.00290*WGP6+.93
  IF(S(850).GT.0.) W(650)=S(850)
DO 78 K=600,651
  WTGP6=WTGP6+W(K)
78 CONTINUE
      CALC ARMAMENT WEIGHTS --GROUP 7
  W(704)=W(774)+W(784)
  W(720)=0.0
  WGP7=0.0
  WTGP7=0.0
DO 79 I=900,999
  IF(S(I).GT.0.) W(I-200)=S(I)
79 CONTINUE
DO 80 J=700,712
  WGP7=WGP7+W(J)
80 CONTINUE
  W(750)=.0101*WGP7+.66
  IF(S(950).GT.0.) W(750)=S(950)
  W(751)=.0173*WGP7-.88
  IF(S(951).GT.0.) W(751)=S(951)
DO 81 K=700,751
  WTGP7=WTGP7+W(K)
81 CONTINUE
      CALC LOADS WEIGHTS --GROUP 8
  W(800)=.0737*NACSC+.105*NOFF+.0737*NCPO+.0290*NCREW+.0737*NFLAG
  1+.0737*NFLAG
  W(801)=.0737*NTRP+.0370*NTRP
  W(802)=.0737*NPASS+.0290*NPASS
  W(803)=W(873)+W(883)+W(893)
  W(806)=.0164*(NACC*DUR)**.8333
  W(807)=.000755*NACC*DUR+1.81
      REST OF LOADS CALC IN MACHLQ
  
```

WGHT0361
WGHT0362
WGHT0363
WGHT0364
WGHT0365
WGHT0366
WGHT0367
WGHT0368
WGHT0369
WGHT0370
WGHT0371
WGHT0372
WGHT0373
WGHT0374
WGHT0375
WGHT0376

```
VRLOAD=0.0
DO 90 I=1000,1099
IF(S(I).GT.0.) W(I-200)=S(I)
90 CONTINUE
DO 91 J=800,822
VRLOAD=VRLOAD+W(J)
91 CONTINUE
C      CALC LIGHT SHIP WEIGHT
DISPLS=WTGP1+WTGP2+WTGP3+WTGP4+WTGP5+WTGP6+WTGP7
C      CALC WEIGHT MARGIN
WTMARG=DISPLS*DCMARG
IF(W(825).GT.0.) WTMARG=W(825)
C      CALC FULL LOAD DISPLACEMENT
DISPFL=DISPLS+VRLOAD+WTMARG
RETURN
END
```

VTCG0001
VTCG0002
VTCG0003
VTCG0004
VTCG0005
VTCG0006
VTCG0007
VTCG0008
VTCG0009
VTCG0010
VTCG0011
VTCG0012
VTCG0013
VTCG0014
VTCG0015
VTCG0016
VTCG0017
VTCG0018
VTCG0019
VTCG0020
VTCG0021
VTCG0022
VTCG0023
VTCG0024
VTCG0025
VTCG0026
VTCG0027
VTCG0028
VTCG0029
VTCG0030
VTCG0031
VTCG0032
VTCG0033
VTCG0034
VTCG0035
VTCG0036

```

SUBROUTINE VRTCG
REAL LBP,LRD
INTEGER PPTYP
DIMENSION WVG(900)
COMMON/DATA/P(7,300),S(2500),Q(100),IT(100)
COMMON/UND/FSCORK,CP,CX,GMBMIN,KGTRY,B,CWP,LBP,R,LBRAT,BHRAT,DPTRY
COMMON/DEPTH/FO,F10,F20,DO,DMN,D20,H,DECKHT,LRD,DAVG
COMMON/MNMACCH/SHP,NB,NR,NE,NSHFT,PRPTYP,SHFTYP,RPM,DPROP,SHPE
COMMON/CGS/CG1,CG2,CG3,CG4,CG5,CG6,CG7,CGLDS,CGLSP,CGFLD
COMMON/ELPLT/ECR(11),EBT(11),EAV(11),ELMARG,MXFCMK,KW24AV,HTTYP
COMMON/WTGRPS/WTGP1,WTGP2,WTGP3,WTGP4,WTGP5,WTGP6,WTGP7,VRLDAD,
1DISPLS,WTMARG,WBHS,WSS,WDHS,WARM,WFFL,WFG4,WFG5,VOLSHP,WTSHIP
COMMON/WTMOM/W(900),VM(900),VCG(900),WPAYIN,DCMARG,DISPFL,VWT(400)
COMMON/PROPPW/VSPUS,VEND,DELCPF,PPTYP,JHPOPT,PCMXSP,PCEND,ENDUR
HLBP=LBP/2.
D10=DMN
IF(LRD.GE.HLRP) D10=DMN+DECKHT
HULL STRUCTURE VCGS
VCG(100)=.3661*D10+1.45
VCG(101)=.1999*D10+4.94
VCG(102)=.1139*D10+.91
VCG(103)=1.029*H-2.59
VCG(107)=.8289*D10+3.54
VCG(111)=1.2334*D10+4.44
GO TO (3,3,3,1,2,2,3,2),PPTYP
1 VCG(112)=.2324*H+10.00
GO TO 5
2 VCG(112)=.5784*H
GO TO 5
3 VCG(112)=.9257*H-8.68
5 CONTINUE
VCG(113)=.2607*H+9.94
VCG(114)=.6216*D10-2.54
VCG(115)=.4623*D10+5.27
VCG(118)=.4529*D10
VCG(119)=.3055*D10+2.80

```

VTCG0037
 VTCG0038
 VTCG0039
 VTCG0040
 VTCG0041
 VTCG0042
 VTCG0043
 VTCG0044
 VTCG0045
 VTCG0046
 VTCG0047
 VTCG0048
 VTCG0049
 VTCG0050
 VTCG0051
 VTCG0052
 VTCG0053
 VTCG0054
 VTCG0055
 VTCG0056
 VTCG0057
 VTCG0058
 VTCG0059
 VTCG0060
 VTCG0061
 VTCG0062
 VTCG0063
 VTCG0064
 VTCG0065
 VTCG0066
 VTCG0067
 VTCG0068
 VTCG0069
 VTCG0070
 VTCG0071
 VTCG0072

VCG(120)=.2436*H+1.29
 VCG(122)=.7288*D10
 VCG(123)=.8815*D10-.14
 VCG(125)=.5461*D10+65.75
 VCG(150)=.5829*D10+.68
 VCG(151)=.348*H
 PROPULSION VCGS
 VCG(200)=.000271*SHP/NSHFT+4.47
 IF(PPTYP.EQ.4) VCG(200)=.000322*SHP/NSHFT+7.58
 VCG(201)=.809*H+1.09
 VCG(202)=.5611*H+.36
 VCG(203)=.6603*H-5.54
 GO TO (6,6,7,6,8,6,8),PPTYP
 6 VCG(204)=.000180*SHP/NSHFT+17.45
 GO TO 10
 7 VCG(204)=.506*D10
 GO TO 10
 8 VCG(204)=1.13*D10
 10 CONTINUE
 VCG(205)=1.467*D10+9.00
 VCG(206)=.4381*D10+6.23
 VCG(207)=.5178*D10+4.94
 VCG(208)=.2643*D10+5.24
 VCG(209)=.2234*D10+1.21
 VCG(210)=.4219*H+4.12
 VCG(211)=.3492*D10-1.04
 VCG(250)=.1479*D10+11.48
 VCG(251)=.9992*H-4.74
 ELECTRIC PLANT VCGS
 VCG(300)=.5829*H+7.40
 VCG(301)=.4431*D10+5.89
 VCG(302)=.4432*D10+10.49
 VCG(303)=.8399*D10+1.71
 VCG(350)=.5471*D10-1.63
 VCG(351)=.3542*D10+1.48
 COMMUNICATION AND CONTROL VCGS

C

C

C

VTCG0073
VTCG0074
VTCG0075
VTCG0076
VTCG0077
VTCG0078
VTCG0079
VTCG0080
VTCG0081
VTCG0082
VTCG0083
VTCG0084
VTCG0085
VTCG0086
VTCG0087
VTCG0088
VTCG0089
VTCG0090
VTCG0091
VTCG0092
VTCG0093
VTCG0094
VTCG0095
VTCG0096
VTCG0097
VTCG0098
VTCG0099
VTCG0100
VTCG0101
VTCG0102
VTCG0103
VTCG0104
VTCG0105
VTCG0106
VTCG0107
VTCG0108

VCG(400)=1.1534*D10+12.19
VCG(401)=.7251*D10+3.07
VCG(403)=.5068*D10+7.04
VCG(410)=55.0
VCG(450)=.2659*D10+19.89
 AUXILIARY SYSTEMS VCGS
VCG(500)=.7209*D10+3.08
IF(HTYP.EQ.2.) VCG(500)=.3867*D10
VCG(501)=.7663*D10+7.44
VCG(502)=.2779*D10+11.11
VCG(503)=2.4468*H-22.62
VCG(504)=.8323*D10-7.28
VCG(505)=.6806*D10+4.26
VCG(506)=.8267*D10-3.33
VCG(507)=.7804*D10+.95
VCG(508)=.1610*D10+4.71
VCG(509)=.4265*D10+8.39
VCG(510)=.2834*D10+22.42
VCG(511)=1.2224*H-6.44
VCG(512)=.3278*H+.6557
VCG(513)=16.4
VCG(514)=.8126*H+5.53
IF(PPTY.GE.5.AND.PPTY.LE.6) VCG(514)=.7735*H
VCG(516)=.308*D10
VCG(517)=.9938*H+1.73
VCG(518)=1.8139*H-13.10
VCG(519)=.6428*H+2.40
VCG(520)=.6252*D10+3.82
VCG(521)=.8655*D10+8.24
VCG(527)=.4878*H
VCG(550)=.2804*D10+8.53
VCG(551)=.5007*D10+2.77
 OUTFIT AND FURNISHINGS VCGS
VCG(600)=.7772*D10+11.86
VCG(601)=1.0081*D10+10.63
VCG(602)=1.0183*D10+10.99

C

C

VTCG0109
VTCG0110
VTCG0111
VTCG0112
VTCG0113
VTCG0114
VTCG0115
VTCG0116
VTCG0117
VTCG0118
VTCG0119
VTCG0120
VTCG0121
VTCG0122
VTCG0123
VTCG0124
VTCG0125
VTCG0126
VTCG0127
VTCG0128
VTCG0129
VTCG0130
VTCG0131
VTCG0132
VTCG0133
VTCG0134
VTCG0135
VTCG0136
VTCG0137
VTCG0138
VTCG0139
VTCG0140
VTCG0141
VTCG0142
VTCG0143
VTCG0144

VCG(603)=.3082*D10+7.18
VCG(604)=.8684*D10+3.15
VCG(605)=.4282*D10+7.64
VCG(606)=.9046*D10-1.03
VCG(607)=.5420*D10+10.80
VCG(608)=.4503*D10+7.47
VCG(609)=.5927*D10+5.92
VCG(610)=.9440*D10-4.55
VCG(611)=.8384*D10+2.86
VCG(612)=.8037*D10+1.75
VCG(613)=1.0519*D10-.42
VCG(614)=.4172*D10+15.28
VCG(615)=VCG(703)
VCG(650)=1.1088*D10-13.58

C
ARMAMENT VCGS
VCG(750)=.546*D10+1.44
VCG(751)=32.7

C
LOADS VCGS
VCG(800)=.7076*D10+1.41
VCG(801)=VCG(800)
VCG(802)=VCG(800)
VCG(806)=.5932*D10-2.99
VCG(807)=.2840*D10+13.54
VCG(812)=4.2
VCG(813)=4.7
VCG(814)=1.1519*H-2.20
VCG(816)=.2515*H+4.27
VCG(817)=12.5

C
IF(PPTYP.EQ.7) VCG(817)=VCG(816)
CALC VCGS OF PAYLOAD ITEMS
DO 11 J=1,900
11 WVG(J)=0.0
DO 15 I=1,100
IF(IT(I).EQ.0) GO TO 15
IF(P(1,IT(I)).EQ.0.) GO TO 15
IF(P(5,IT(I))-2.) 12,13,14

VTCG0145
VTCG0146
VTCG0147
VTCG0148
VTCG0149
VTCG0150
VTCG0151
VTCG0152
VTCG0153
VTCG0154
VTCG0155
VTCG0156
VTCG0157
VTCG0158
VTCG0159
VTCG0160
VTCG0161
VTCG0162
VTCG0163
VTCG0164
VTCG0165
VTCG0166
VTCG0167
VTCG0168
VTCG0169
VTCG0170
VTCG0171
VTCG0172
VTCG0173
VTCG0174
VTCG0175
VTCG0176
VTCG0177
VTCG0178
VTCG0179
VTCG0180

```

12 VCG(P(1,IT(I)))=(VCG(P(1,IT(I)))*WVG(P(1,IT(I)))+Q(I)*P(3,IT(I))
  1*(D10+P(4,IT(I)))/(WVG(P(1,IT(I)))+Q(I)*P(3,IT(I)))
  WVG(P(1,IT(I)))=WVG(P(1,IT(I)))+Q(I)*P(3,IT(I))
  GO TO 15
13 VCG(P(1,IT(I)))=(VCG(P(1,IT(I)))*WVG(P(1,IT(I)))+Q(I)*P(3,IT(I))
  1*P(4,IT(I)))/(WVG(P(1,IT(I)))+Q(I)*P(3,IT(I)))
  WVG(P(1,IT(I)))=WVG(P(1,IT(I)))+Q(I)*P(3,IT(I))
  GO TO 15
14 VCG(P(1,IT(I)))=(VCG(P(1,IT(I)))*WVG(P(1,IT(I)))+Q(I)*P(3,IT(I))
  1*(D10*P(4,IT(I)))/(WVG(P(1,IT(I)))+Q(I)*P(3,IT(I)))
  WVG(P(1,IT(I)))=WVG(P(1,IT(I)))+Q(I)*P(3,IT(I))
15 CONTINUE
      CALC VCGS OF SPECIAL PAYLOAD ITEMS
      DO 16 K=2300,2499,10
      IF(S(K).EQ.0.) GO TO 16
      IF(S(K+4)-2.) 17,18,19
17 VCG(S(K))=(VCG(S(K))*WVG(S(K))+S(K+2)*(D10+S(K+3)))/(WVG(S(K))+
  1S(K+2))
      WVG(S(K))=WVG(S(K))+S(K+2)
      GO TO 16
18 VCG(S(K))=(VCG(S(K))*WVG(S(K))+S(K+2)*S(K+3))/(WVG(S(K))+S(K+2))
      WVG(S(K))=WVG(S(K))+S(K+2)
      GO TO 16
19 VCG(S(K))=(VCG(S(K))*WVG(S(K))+S(K+2)*(D10*S(K+3)))/(WVG(S(K))+
  1S(K+2))
      WVG(S(K))=WVG(S(K))+S(K+2)
16 CONTINUE
      CHECK FOR VCG DIRECT INPUT
      DO 20 I=1100,1899
      IF(S(I).GT.0.) VCG(I-1000)=S(I)
20 CONTINUE
      RECALC VCG OF APPROPRIATE PAYLOAD ITEMS
      IF(W(406).GT.0.) VCG(406)=(VCG(486)*W(486)+VCG(496)*W(496))/W(406)
      IF(W(704).GT.0.) VCG(704)=(VCG(774)*W(774)+VCG(784)*W(784))/W(704)
      IF(W(803).GT.0.) VCG(803)=(VCG(873)*W(873)+VCG(883)*W(883))+
  1VCG(893)*W(893))/W(803)

```

C

C

C

VTCG0181
VTCG0182
VTCG0183
VTCG0184
VTCG0185
VTCG0186
VTCG0187
VTCG0188
VTCG0189
VTCG0190
VTCG0191
VTCG0192
VTCG0193
VTCG0194
VTCG0195
VTCG0196
VTCG0197
VTCG0198
VTCG0199
VTCG0200
VTCG0201
VTCG0202
VTCG0203
VTCG0204
VTCG0205
VTCG0206
VTCG0207
VTCG0208
VTCG0209
VTCG0210
VTCG0211
VTCG0212
VTCG0213
VTCG0214
VTCG0215
VTCG0216

```
IF(S(1406).GT.0.) VCG(406)=S(1406)
IF(S(1704).GT.0.) VCG(704)=S(1704)
IF(S(1803).GT.0.) VCG(803)=S(1803)
      NDW CALC MOMENTS
DO 21 I=1,900
VM(I)=W(I)*VCG(I)
21 CONTINUE
      CALC VCG OF ALL WEIGHT GROUPS
VMGP1=VMGP2+VMGP3=VMGP4=VMGP5=VMGP6=VMGP7=VMLOAD=VMMG=VMLS=VMFL=0.
DO 22 J=100,151
VMGP1=VMGP1+VM(J)
22 CONTINUE
CG1=VMGP1/WTGP1
DO 23 J=200,251
VMGP2=VMGP2+VM(J)
23 CONTINUE
CG2=VMGP2/WTGP2
DO 24 J=300,351
VMGP3=VMGP3+VM(J)
24 CONTINUE
CG3=VMGP3/WTGP3
DO 25 J=400,451
VMGP4=VMGP4+VM(J)
25 CONTINUE
CG4=VMGP4/WTGP4
DO 26 J=500,551
VMGP5=VMGP5+VM(J)
26 CONTINUE
CG5=VMGP5/WTGP5
DO 27 J=600,651
VMGP6=VMGP6+VM(J)
27 CONTINUE
CG6=VMGP6/WTGP6
DO 28 J=700,751
VMGP7=VMGP7+VM(J)
28 CONTINUE
```

VTCG0217
VTCG0218
VTCG0219
VTCG0220
VTCG0221
VTCG0222
VTCG0223
VTCG0224
VTCG0225
VTCG0226
VTCG0227
VTCG0228

CG7=VMGP7/WTGP7
DO 29 J=800,822
VMLOAD=VMLOAD+VM(J)
29 CONTINUE
CGLDS=VMLOAD/VRLOAD
VMMG=VCG(825)*W(825)
VMLS=VMGP1+VMGP2+VMGP3+VMGP4+VMGP5+VMGP6+VMGP7
CGLSP=VMLS/DISPLS
VMFL=VMLS+VMLOAD+VMMG
CGFLD=VMFL/DISPFL
RETURN
END

FGRP0001
 FGRP0002
 FGRP0003
 FGRP0004
 FGRP0005
 FGRP0006
 FGRP0007
 FGRP0008
 FGRP0009
 FGRP0010
 FGRP0011
 FGRP0012
 FGRP0013
 FGRP0014
 FGRP0015
 FGRP0016
 FGRP0017
 FGRP0018
 FGRP0019
 FGRP0020
 FGRP0021
 FGRP0022
 FGRP0023
 FGRP0024
 FGRP0025
 FGRP0026
 FGRP0027
 FGRP0028
 FGRP0029
 FGRP0030
 FGRP0031
 FGRP0032
 FGRP0033
 FGRP0034
 FGRP0035
 FGRP0036

```

SUBROUTINE FNCGRP
COMMON/WTMOM/W(900), VM(900), VCG(900), WPAYIN, DCMARG, DISPFL, VWT(400)
COMMON/VOLUM/V(400), VOLTOT, VOL SST, VOLHUL, VOLMB, FNDEN(400)
COMMON/ELPLT/ECR(11), EBT(11), EAV(11), ELMARG, MXFCKW, KW24AV, HTTYP
COMMON/PEOPLE/NACC, NOFF, NCPO, NCREW, NFLAG, NTRP, NPASS, DUR, NACSC
COMMON/WTGRPS/WTGP1, WTGP2, WTGP3, WTGP4, WTGP5, WTGP6, WTGP7, VRLOAD,
1DISPLS, WTMARG, WBHS, WSS, WDHS, WARM, WFFL, WFG4, WFG5, VOLSHIP, WTSHIP
C      CALC WEIGHT AND DENSITY ASSOCIATED WITH EACH VOLUME GROUPING
VWT(111)=W(409)
VWT(112)=W(408)
VWT(113)=W(412)
VWT(114)=W(404)
VWT(115)=W(413)
VWT(116)=W(415)+W(450)+W(451)
DO 1 I=111, 116
V(110)=V(110)+V(I)
VWT(110)=VWT(110)+VWT(I)
IF(V(I).GT.0.) FNDEN(I)=2240.*VWT(I)/V(I)
1 CONTINUE
VWT(121)=W(402)+W(700)+W(873)
VWT(122)=W(405)+W(774)+W(883)
VWT(123)=W(486)+W(784)+W(708)+W(893)
VWT(124)=W(710)
VWT(125)=W(711)
VWT(126)=W(403)
VWT(127)=W(750)+W(751)+W(810)
VWT(128)=W(703)+W(615)
DO 2 I=121, 128
V(120)=V(120)+V(I)
VWT(120)=VWT(120)+VWT(I)
IF(V(I).GT.0.) FNDEN(I)=2240.*VWT(I)/V(I)
2 CONTINUE
WCONT=V(131)/(V(131)+V(221)+V(313))*W(613)
VWT(131)=W(496)+WCONT
VWT(132)=W(523)+W(524)+W(525)+W(805)
VWT(133)=W(809)+W(811)

```

FGRP0037
 FGRP0038
 FGRP0039
 FGRP0040
 FGRP0041
 FGRP0042
 FGRP0043
 FGRP0044
 FGRP0045
 FGRP0046
 FGRP0047
 FGRP0048
 FGRP0049
 FGRP0050
 FGRP0051
 FGRP0052
 FGRP0053
 FGRP0054
 FGRP0055
 FGRP0056
 FGRP0057
 FGRP0058
 FGRP0059
 FGRP0060
 FGRP0061
 FGRP0062
 FGRP0063
 FGRP0064
 FGRP0065
 FGRP0066
 FGRP0067
 FGRP0068
 FGRP0069
 FGRP0070
 FGRP0071
 FGRP0072

```

VWT(134)=W(815)+W(819)
VWT(135)=W(712)+W(804)
DO 3 I=131,135
V(130)=V(130)+V(I)
VWT(130)=VWT(130)+VWT(I)
IF(V(I).GT.0.) FNDEN(I)=2240.*VWT(I)/V(I)
3 CONTINUE
VWT(140)=W(801)+W(808)
VWT(150)=W(720)+W(821)
VWT(160)=.0737*NFLAG#2.
VWT(170)=W(802)
VWT(180)=W(529)
DO 4 I=110,180,10
V(100)=V(100)+V(I)
VWT(100)=VWT(100)+VWT(I)
IF(V(I).GT.0.) FNDEN(I)=2240.*VWT(I)/V(I)
4 CONTINUE
IF(V(100).GT.0.) FNDEN(100)=2240.*VWT(100)/V(100)
WFURN=(V(211)+V(212)+V(214)+V(215)+V(217)+V(218))/(V(211)+V(212)+
1V(214)+V(215)+V(217)+V(218)+V(225))*W(612)
VWT(210)=WFURN+.2*W(505)+W(800)-VWT(160)-.04*NDFF-.03*NCPO-.015*
1NCREW
DO 5 I=211,219
V(210)=V(210)+V(I)
5 CONTINUE
IF(V(210).GT.0.) FNDEN(210)=2240.*VWT(210)/V(210)
VWT(221)=V(221)/(V(131)+V(221)+V(313))*W(613)
VWT(222)=W(611)
VWT(223)=W(614)
VWT(224)=W(609)
VWT(225)=W(612)-WFURN
VWT(226)=W(594)
DO 6 I=221,226
V(220)=V(220)+V(I)
VWT(220)=VWT(220)+VWT(I)
IF(V(I).GT.0.) FNDEN(I)=2240.*VWT(I)/V(I)
  
```

FGRP0073
 FGRP0074
 FGRP0075
 FGRP0076
 FGRP0077
 FGRP0078
 FGRP0079
 FGRP0080
 FGRP0081
 FGRP0082
 FGRP0083
 FGRP0084
 FGRP0085
 FGRP0086
 FGRP0087
 FGRP0088
 FGRP0089
 FGRP0090
 FGRP0091
 FGRP0092
 FGRP0093
 FGRP0094
 FGRP0095
 FGRP0096
 FGRP0097
 FGRP0098
 FGRP0099
 FGRP0100
 FGRP0101
 FGRP0102
 FGRP0103
 FGRP0104
 FGRP0105
 FGRP0106
 FGRP0107
 FGRP0108

```

6 CONTINUE
  IF(V(220).GT.0.) FNDEN(220)=2240.*VWT(220)/V(220)
  VWT(231)=W(806)
  VWT(232)=(1./3.)*W(608)+.04*NOFF+.03*NCPO+.015*NCREW
  VWT(233)=W(812)
  DO 7 I=231,233
    V(230)=V(230)+V(I)
  VWT(230)=VWT(230)+VWT(I)
  IF(V(I).GT.0.) FNDEN(I)=2240.*VWT(I)/V(I)
7 CONTINUE
  IF(V(230).GT.0.) FNDEN(230)=2240.*VWT(230)/V(230)
  DO 8 I=210,230,10
    V(200)=V(200)+V(I)
  VWT(200)=VWT(200)+VWT(I)
8 CONTINUE
  IF(V(200).GT.0.) FNDEN(200)=2240.*VWT(200)/V(200)
  VWT(311)=W(400)+W(401)+W(410)+W(411)
  VWT(313)=V(313)/(V(131)+V(221)+V(313))*W(613)
  DO 9 I=311,313
    V(310)=V(310)+V(I)
  VWT(310)=VWT(310)+VWT(I)
  IF(V(I).GT.0.) FNDEN(I)=2240.*VWT(I)/V(I)
9 CONTINUE
  VWT(321)=W(200)+W(201)+W(202)+W(204)+W(206)+W(207)+W(208)+W(209)
  1+W(210)+W(211)+W(251)+W(300)+W(301)+W(351)+W(502)+W(503)+W(504)
  2-W(594)+W(512)+W(513)+W(514)+W(517)+W(527)+W(551)+(2./3.)*W(603)
  VWT(322)=W(205)
  VWT(323)=W(203)
  VWT(324)=W(518)+W(519)
  VWT(325)=W(501)*.8
  DO 10 I=321,325
    V(320)=V(320)+V(I)
  VWT(320)=VWT(320)+VWT(I)
  IF(V(I).GT.0.) FNDEN(I)=2240.*VWT(I)/V(I)
10 CONTINUE
  VWT(331)=W(520)+W(600)

```

FGRP0109
 FGRP0110
 FGRP0111
 FGRP0112
 FGRP0113
 FGRP0114
 FGRP0115
 FGRP0116
 FGRP0117
 FGRP0118
 FGRP0119
 FGRP0120
 FGRP0121
 FGRP0122
 FGRP0123
 FGRP0124
 FGRP0125
 FGRP0126
 FGRP0127
 FGRP0128
 FGRP0129
 FGRP0130
 FGRP0131
 FGRP0132
 FGRP0133
 FGRP0134
 FGRP0135
 FGRP0136
 FGRP0137
 FGRP0138
 FGRP0139
 FGRP0140
 FGRP0141
 FGRP0142
 FGRP0143
 FGRP0144

```

VWT(332)=W(528)
V(330)=V(331)+V(332)
VWT(330)=VWT(331)+VWT(332)
DO 11 I=331,332
  IF(V(I).GT.0.) FNDEN(I)=2240.*VWT(I)/V(I)
11 CONTINUE
VWT(341)=V(341)/(V(341)+V(342)+V(343))*W(610)
VWT(342)=V(342)/(V(341)+V(342)+V(343))*W(610)
VWT(343)=V(343)/(V(341)+V(342)+V(343))*W(610)+W(605)
DO 12 I=341,343
  V(340)=V(340)+V(I)
VWT(340)=VWT(340)+VWT(I)
IF(V(I).GT.0.) FNDEN(I)=2240.*VWT(I)/V(I)
12 CONTINUE
VWT(351)=W(816)
VWT(352)=W(813)
VWT(353)=W(814)
VWT(354)=W(817)
VWT(355)=W(818)+W(820)
VWT(356)=(2./3.)*W(608)+W(250)+W(350)+W(550)+W(650)+W(807)
VWT(357)=W(601)
DO 13 I=351,357
  V(350)=V(350)+V(I)
VWT(350)=VWT(350)+VWT(I)
IF(V(I).GT.0.) FNDEN(I)=2240.*VWT(I)/V(I)
13 CONTINUE
VWT(361)=W(822)
DO 14 I=361,365
  V(360)=V(360)+V(I)
VWT(360)=VWT(360)+VWT(I)
IF(V(I).GT.0.) FNDEN(I)=2240.*VWT(I)/V(I)
14 CONTINUE
VWT(370)=(1./3.)*W(603)
DO 15 I=310,390,10
  V(300)=V(300)+V(I)
VWT(300)=VWT(300)+VWT(I)

```

FGRP0145
FGRP0146
FGRP0147
FGRP0148
FGRP0149
FGRP0150
FGRP0151
FGRP0152
FGRP0153
FGRP0154
FGRP0155
FGRP0156
FGRP0157
FGRP0158
FGRP0159
FGRP0160
FGRP0161
FGRP0162

```
15 IF(V(I).GT.0.) FNDEN(I)=2240.*VWT(I)/V(I)
CONTINUE
IF(V(300).GT.0.) FNDEN(300)=2240.*VWT(300)/V(300)
WBHS=W(100)+W(101)+W(107)*.5+.7*W(150)
WSS=W(102)+W(103)+W(112)+W(114)+W(115)+W(118)+W(119)+W(120)+W(121)
1+W(122)+W(123)+W(125)+W(127)+W(128)+.3*W(150)+W(510)+W(604)+W(113)
2+W(116)+W(107)*.5
WDHS=W(111)
WARM=W(117)
WFFL=W(151)
WFG4=WBHS+WSS+WDHS+WARM+WFFL
WFG5=W(302)+W(303)+W(500)+W(506)+W(507)+.2*W(501)+W(508)+W(511)+
1W(516)+W(521)+W(522)+W(526)+W(606)+W(607)+W(651)+WTMARG+W(509)
2+.8*W(505)
VOLSHP=V(100)+V(200)+V(300)
WTSHIP=VWT(100)+VWT(200)+VWT(300)+WFG4+WFG5
RETURN
END
```

```

SURROUTINE SEASPD(AVSP)
INTEGER PPTYP
REAL LEN,KGTRY,KY,IY,JY,KYY,LBP,LBRAT,LRD
COMMON/PROPPW/VSPUS,VEND,DELCF,PPTYP,JHPOPT,PCMXSP,PCEND,ENDUR
COMMON/UND/FSCORR,CP,CX,GMBMIN,KGTRY,B,CWP,LBP,R,LBRAT,BHRAT,DPTRY
COMMON/DEPTH/FO,F10,F20,DO,D10,D20,H,DECKHT,LRD,DAVG
KY=.24
G=32.155
R=1.9905
LEN=LBP
PI=3.14159
IY=(KY*LEN)**2*2240.*DPTRY/G
CIL=.14210526*CWP-.063568
JY=CIL*B*LEN**3
C=H
B1=B/2.
A=LEN/2.
BCC=B1/C+1.19-(1.64-.86666697E-1*A/B1+.625E-2*(A/B1)**2-.20833346E
1-3*(A/B1)**3)
YK1=.66302837E-1+.5773045*BCC+.31592344*BCC**2-.15287906*BCC**3
1+.028399747*BCC**4
IF(CX-.814)1,2,3
3 CXP=(CX-.814)*.81395
CXH=(CX-.814)*.60465
GO TO 4
2 CXP=0.
CXH=0.
GO TO 4
1 CXP=0.
CXH=(CX-.814)*.27193
4 FKYY=.6051
CPP=(CP-.58)*2.76666
CSP=FKYY+CPP+CXP
IYY=YK1*CSP/120.*PI*R*LEN*B*H*(LEN*LEN+4.*H*H)
TP=2.*PI*((IY+IYY)/(G*R*JY))**.5
ZK1=1.9+(B1/C-2.)/1.05

```

```

SEAS0001
SEAS0002
SEAS0003
SEAS0004
SEAS0005
SEAS0006
SEAS0007
SEAS0008
SEAS0009
SEAS0010
SEAS0011
SEAS0012
SEAS0013
SEAS0014
SEAS0015
SEAS0016
SEAS0017
SEAS0018
SEAS0019
SEAS0020
SEAS0021
SEAS0022
SEAS0023
SEAS0024
SEAS0025
SEAS0026
SEAS0027
SEAS0028
SEAS0029
SEAS0030
SEAS0031
SEAS0032
SEAS0033
SEAS0034
SEAS0035
SEAS0036

```

SEAS0037
 SEAS0038
 SEAS0039
 SEAS0040
 SEAS0041
 SEAS0042
 SEAS0043
 SEAS0044
 SEAS0045
 SEAS0046
 SEAS0047
 SEAS0048
 SEAS0049
 SEAS0050
 SEAS0051
 SEAS0052
 SEAS0053
 SEAS0054
 SEAS0055
 SEAS0056
 SEAS0057
 SEAS0058
 SEAS0059
 SEAS0060
 SEAS0061
 SEAS0062
 SEAS0063
 SEAS0064
 SEAS0065
 SEAS0066
 SEAS0067
 SEAS0068
 SEAS0069
 SEAS0070
 SEAS0071
 SEAS0072

```

FKZ=.599
CPH=(CP-.58)*1.41666
CSH=FKZ+CPH+CXH
SM=2240.*DPTRY/G
AWP=CWP*LEN*B
ZM=CSH*ZK1*PI*R*LEN*B*H/6.
TH=6.28318*SQR((SM+ZM)/(G*R*AWP))
TPL=TP/(SQR(T(LEN)))
THL=TH/(SQR(T(LEN)))
T=TPL
IF(THL.GT.TPL) T=THL
VLR=(.9025/T-SQR(.95*G/(2.*PI)))/1.6878
WAVEH=.0256465*LEN
W=DPTRY/(100.*(01*LEN)**3)
WW=(11.*W*W-8.25281*W+3.86439)/6000.
VRT=16.*H/LEN+.60293*W-.15617+WW*LEN
VLR=VRT*VLR
SPEED=VLR*SQR(T(LEN))
IF(SPEED.LT.VSUS) GO TO 6
PER1=100.
GO TO 5
6 IF(WAVEH.LT.8.) GO TO 7
IF(WAVEH.LT.13.) GO TO 8
PER1=-40.49996+14.949994*WAVEH-.54333305*WAVEH**2+.66666623E-2*
1WAVEH**3
GO TO 5
8 PER1=-126.00002+21.933338*WAVEH-.25625043*WAVEH**2-.017708321*
1WAVEH**3
GO TO 5
7 PER1=-.89785317E-7+.14285863*WAVEH-.13333482*WAVEH**2+.037500399*
1WAVEH**3+.29761609E-2*WAVEH**4
5 PER2=(100.-PER1)/?.
PER=100.-PER2
AVSP=(PER*VSUS+PER2*SPEED)/100.
RETURN
END

```

OUTP0001
OUTP0002
OUTP0003
OUTP0004
OUTP0005
OUTP0006
OUTP0007
OUTP0008
OUTP0009
OUTP0010
OUTP0011
OUTP0012
OUTP0013
OUTP0014
OUTP0015
OUTP0016
OUTP0017
OUTP0018
OUTP0019
OUTP0020
OUTP0021
OUTP0022
OUTP0023
OUTP0024
OUTP0025
OUTP0026
OUTP0027
OUTP0028
OUTP0029
OUTP0030
OUTP0031
OUTP0032
OUTP0033
OUTP0034
OUTP0035
OUTP0036

SUBROUTINE OUTPUT
REAL LBP,KGTRY,LRD,LBRAT
REAL*8 NS(100),NTYP(50),NSR(70),NCOMP(400),NWT(830),NELC(20)
INTEGER PPTYP,SSETYP,EMETYP
DIMENSION SR(70)
COMMON/VALUES/NS,NTYP,NSR,NCOMP,NWT,NELC
COMMON/OUT/PRTOUT,AVSP,EXCKG,ICONST,NSHIP
COMMON/PROPPW/VSP,VEND,DELCF,PPTYP,JHPOPT,PCMXSP,PCEND,ENDUR
COMMON/GENSZ/KWSSER,KWEMER,KWINST,SSETYP,EMETYP,NLSD,NMSD,NHSD,
INGTG,NSTG,KWPRD,KWPRGT,KWPRSG,NGFCLD,NGAVG,NSSG,NEMG,KELEC
COMMON/MNMACH/SHP,NB,NR,NE,NSHFT,PRPTYP,SHFTYP,RPM,DPROP,SHPE
COMMON/MISC/FINST,HULMAT,SSMAT,PASTYP
COMMON/ELPLT/ECR(11),EBT(11),EAV(11),ELMARG,MXFCWK,KW24AV,HTTYP
COMMON/DATA/P(7,300),S(2500),Q(100),IT(100)
COMMON/UND/FSCORR,CP,CX,GMBMIN,KGTRY,B,CWP,LBP,R,LBRAT,BHRAT,DPTRY
COMMON/DEPTH/FO,F10,F20,D0,D10,D20,H,DECKHT,LRD,DAVG
COMMON/CGS/CG1,CG2,CG3,CG4,CG5,CG6,CG7,CGLDS,CGLSP,CGFLD
COMMON/PEOPLE/NACC,NOFF,NCPO,NCREW,NFLAG,NTRP,NPASS,DUR,NACSC
COMMON/WTMOM/W(900),VM(900),VCG(900),WPAYIN,DCMARG,DISPFL,VWT(400)
COMMON/WTGRPS/WTGP1,WTGP2,WTGP3,WTGP4,WTGP5,WTGP6,WTGP7,VRLOAD,
1DISPLS,WTMARG,WBHS,WSS,WDHS,WARM,WFFL,WFG4,WFG5,VOLSHIP,WTSHIP
COMMON/VOLUM/V(400),VOLTOT,VOLSSST,VOLHUL,VOLMB,FNDEN(400)

PRINT THE SPECIFICATIONS

IF(PPTYP.EQ.1) NTYP(1)=NTYP(16)
IF(PPTYP.EQ.2) NTYP(1)=NTYP(17)
IF(PPTYP.EQ.3) NTYP(1)=NTYP(18)
IF(PPTYP.EQ.4) NTYP(1)=NTYP(19)
IF(PPTYP.EQ.5) NTYP(1)=NTYP(20)
IF(PPTYP.EQ.6) NTYP(1)=NTYP(21)
IF(PPTYP.EQ.7) NTYP(1)=NTYP(22)
IF(PPTYP.EQ.8) NTYP(1)=NTYP(23)
IF(SSETYP.EQ.1) NTYP(2)=NTYP(24)
IF(SSETYP.EQ.2) NTYP(2)=NTYP(25)
IF(SSETYP.EQ.3) NTYP(2)=NTYP(26)
IF(SSETYP.EQ.4) NTYP(2)=NTYP(27)
IF(SSETYP.EQ.5) NTYP(2)=NTYP(28)

OUTP0037
 OUTP0038
 OUTP0039
 OUTP0040
 OUTP0041
 OUTP0042
 OUTP0043
 OUTP0044
 OUTP0045
 OUTP0046
 OUTP0047
 OUTP0048
 OUTP0049
 OUTP0050
 OUTP0051
 OUTP0052
 OUTP0053
 OUTP0054
 OUTP0055
 OUTP0056
 OUTP0057
 OUTP0058
 OUTP0059
 OUTP0060
 OUTP0061
 OUTP0062
 OUTP0063
 OUTP0064
 OUTP0065
 OUTP0066
 OUTP0067
 OUTP0068
 OUTP0069
 OUTP0070
 OUTP0071
 OUTP0072

```

IF(SSETYP.EQ.6) NTYP(2)=NTYP(29)
IF(EMETYP.EQ.1) NTYP(3)=NTYP(25)
IF(EMETYP.EQ.2) NTYP(3)=NTYP(26)
IF(EMETYP.EQ.3) NTYP(3)=NTYP(27)
IF(EMETYP.EQ.4) NTYP(3)=NTYP(28)
IF(EMETYP.EQ.5) NTYP(3)=NTYP(29)
IF(SHFTYP.EQ.1.) NTYP(6)=NTYP(30)
IF(SHFTYP.EQ.2.) NTYP(6)=NTYP(31)
IF(PRPTY.EQ.1.) NTYP(7)=NTYP(32)
IF(PRPTY.EQ.2.) NTYP(7)=NTYP(33)
IF(FINST.EQ.1.) NTYP(8)=NTYP(34)
IF(FINST.EQ.2.) NTYP(8)=NTYP(35)
IF(HTTYP.EQ.1.) NTYP(9)=NTYP(36)
IF(HTTYP.EQ.2.) NTYP(9)=NTYP(37)
IF(HULMAT.EQ.1.) NTYP(11)=NTYP(38)
IF(HULMAT.EQ.2.) NTYP(11)=NTYP(39)
IF(SSMAT.EQ.1.) NTYP(12)=NTYP(38)
IF(SSMAT.EQ.2.) NTYP(12)=NTYP(39)
IF(PASTYP.EQ.1.) NTYP(13)=NTYP(40)
IF(PASTYP.EQ.2.) NTYP(13)=NTYP(41)
PRINT 7,NSHIP
7 FORMAT(1H1,10X,'SHIP NUMBER',I4)
PRINT 11
11 FORMAT(1H0,32X,'SHIP SPECIFICATIONS'/)
S(26)=S(26)*10000.0
DO 12 J=1,25
12 PRINT 13,NS(J),S(J),NS(J+25),S(J+50),NS(J+50),S(J+50)
13 FORMAT(1H ,10X,3(A8,F10.2,3X))
S(26)=S(26)/10000.0
PRINT 9
9 FORMAT(1H )
DO 14 J=1,5
14 PRINT 15,NS(J+75),NTYP(J),NS(J+80),NTYP(J+5),NS(J+85),NTYP(J+10)
15 FORMAT(1H ,10X,3(A8,3X,A8,2X))
PRINT THE SPECIAL PAYLOAD INPUT
SPEC=0.
  
```

OUTP0073
OUTP0074
OUTP0075
OUTP0076
OUTP0077
OUTP0078
OUTP0079
OUTP0080
OUTP0081
OUTP0082
OUTP0083
OUTP0084
OUTP0085
OUTP0086
OUTP0087
OUTP0088
OUTP0089
OUTP0090
OUTP0091
OUTP0092
OUTP0093
OUTP0094
OUTP0095
OUTP0096
OUTP0097
OUTP0098
OUTP0099
OUTP0100
OUTP0101
OUTP0102
OUTP0103
OUTP0104
OUTP0105
OUTP0106
OUTP0107
OUTP0108

```
PRINT 16
16 FORMAT(IH0,32X,'SPECIAL PAYLOAD INPUT',//IH ,10X,'WT GRP',4X,
1 VOL GRP',4X,'WT',4X,'VCG NU',4X,'VCG REF',4X,'AREA SUP',4X,
2 AREA HULL',//)
DO 17 J=2300,2499,10
IF(S(J).EQ.0..AND.S(J+1).EQ.0.) GO TO 17
PRINT 20,S(J),S(J+1),S(J+2),S(J+3),S(J+4),S(J+5),S(J+6)
20 FORMAT(IH ,10X,F5.0,6X,F5.0,2X,F7.1,3X,F5.1,5X,F3.0,7X,F7.1,6X,
1F7.1)
SPEC=1.0
17 CONTINUE
IF(SPEC.EQ.1.) GO TO 21
PRINT 22
22 FORMAT(IH ,10X,'NO SPECIAL PAYLOAD INPUT')
21 CONTINUE
PRINT 7,NSHIP
PRINT 400
PRINT THE PAYLOAD SPECIFICATIONS
400 FORMAT(IH0,30X,'PAYLOAD SPECIFICATIONS',//13X,5('QNTY',1X,'ITEM',
14X)')
DO 455 K=1,20
405 IF(Q(K).LE.0) GO TO 415
PRINT 410,Q(K),IT(K)
410 FORMAT(IH+,9X,F8.2,1X,I3)
415 IF(Q(K+20).LE.0) GO TO 425
PRINT 420,Q(K+20),IT(K+20)
420 FORMAT(IH+,22X,F8.2,1X,I3)
425 IF(Q(K+40).LE.0) GO TO 435
PRINT 430,Q(K+40),IT(K+40)
430 FORMAT(IH+,35X,F8.2,1X,I3)
435 IF(Q(K+60).LE.0) GO TO 445
PRINT 440,Q(K+60),IT(K+60)
440 FORMAT(IH+,48X,F8.2,1X,I3)
445 IF(Q(K+80).LE.0) GO TO 455
PRINT 450,Q(K+80),IT(K+80)
450 FORMAT(IH+,61X,F8.2,1X,I3)
```

C

OUTP0109
OUTP0110
OUTP0111
OUTP0112
OUTP0113
OUTP0114
OUTP0115
OUTP0116
OUTP0117
OUTP0118
OUTP0119
OUTP0120
OUTP0121
OUTP0122
OUTP0123
OUTP0124
OUTP0125
OUTP0126
OUTP0127
OUTP0128
OUTP0129
OUTP0130
OUTP0131
OUTP0132
OUTP0133
OUTP0134
OUTP0135
OUTP0136
OUTP0137
OUTP0138
OUTP0139
OUTP0140
OUTP0141
OUTP0142
OUTP0143
OUTP0144

C 455 PRINT 9
SET DATA FOR RESULTS
SR(1)=LBP
SR(2)=B
SR(3)=H
SR(4)=D0
SR(5)=D10
SR(6)=D20
SR(7)=DAVG+LRD/LBP*DECKHT
SR(8)=LRD
SR(9)=CP
SR(10)=CX
SR(11)=CGFLD
SR(12)=CGFLD/DAVG
SR(13)=LBP/B
SR(14)=B/H
SR(15)=EXCKG
SR(16)=ENDUR
SR(17)=SHP
SR(18)=SHPE
SR(19)=VSUS
SR(20)=VEND
SR(21)=AVSP
SR(22)=NACC
SR(23)=KWINST
SR(24)=KWSSER
SR(25)=KWEMER
SR(26)=DISPFL
SR(27)=DISPLS
SR(28)=VRLOAD
SR(29)=WTMARG
SR(30)=WTGPI
SR(31)=WTGP2
SR(32)=WTGP3
SR(33)=WTGP4
SR(34)=WTGP5

SR(35)=WTGP6
 SR(36)=WTGP7
 SR(37)=VOLTOT
 SR(38)=VOLHUL
 SR(39)=VOLSST
 SR(40)=ECR(11)
 SR(41)=EBT(11)
 SR(42)=EAV(11)
 SR(43)=NLSD
 SR(44)=NMSD
 SR(45)=NHSD
 SR(46)=NGTG
 SR(47)=NSTG
 SR(48)=KWPRD
 SR(49)=KWPRGT
 SR(50)=KWPRSG
 SR(51)=DISPFL*2240./VOLTOT
 SR(52)=DISPLS*2240./VOLTOT
 SR(53)=VWT(100)/WTSHIP
 SR(54)=VWT(200)/WTSHIP
 SR(55)=VWT(300)/WTSHIP
 SR(56)=V(100)/VOLSHP
 SR(57)=V(200)/VOLSHP
 SR(58)=V(300)/VOLSHP
 SR(59)=WTGP2*2240./SHP
 SR(60)=V(321)/SHP
 SR(61)=WTGP3*2240./KWINST
 SR(62)=WTGP1*2240./VOLTOT
 SR(63)=WTGP5*2240./VOLTOT
 SR(64)=(V(200)-V(230))/NACC
 SR(65)=(VWT(200)-VWT(230))*2240./NACC
 SR(66)=NACC/DISPFL
 SR(67)=KWINST/DISPFL
 SR(68)=SHP/DISPFL
 SR(69)=6.88*DISPFL*VSUS/SHP
 SR(70)=VWT(100)*VSUS/DISPFL

OUTP0145
 OUTP0146
 OUTP0147
 OUTP0148
 OUTP0149
 OUTP0150
 OUTP0151
 OUTP0152
 OUTP0153
 OUTP0154
 OUTP0155
 OUTP0156
 OUTP0157
 OUTP0158
 OUTP0159
 OUTP0160
 OUTP0161
 OUTP0162
 OUTP0163
 OUTP0164
 OUTP0165
 OUTP0166
 OUTP0167
 OUTP0168
 OUTP0169
 OUTP0170
 OUTP0171
 OUTP0172
 OUTP0173
 OUTP0174
 OUTP0175
 OUTP0176
 OUTP0177
 OUTP0178
 OUTP0179
 OUTP0180

```

C          PRINT SUMMARY OF RESULTS
          PRINT 31
          31 FORMAT(IH0,32X,'SUMMARY OF RESULTS'//)
             DO 32 J=1,20
          32 PRINT 33,NSR(J),SK(J),NSR(J+25),SR(J+50),NSR(J+50),SR(J+50)
          33 FORMAT(IH ,10X,3(A8,F10.2,3X))
             DO 34 J=21,25
          34 PRINT 35,NSR(J),SR(J),NSR(J+25),SR(J+25)
          35 FORMAT(IH ,10X,2(A8,F10.2,3X))
             PRINT THE CONSTANTS
             IF(ICONST.NE.1) GO TO 41
             PRINT 7,NSHIP
             PRINT 42
          42 FORMAT(IH0,15X,'SHIP CONSTANTS'//1H ,10X,'ELEMENT NUMBER',5X,
1,VALUE'//)
             DO 43 J=2250,2299
          43 PRINT 44,J,S(J)
          44 FORMAT(IH ,15X,I5,9X,F5.2)
          41 CONTINUE
             PRINT DETAILED FUNCTIONAL GROUPING
             IF(PRTOUT.LT.1.) GO TO 200
             PRINT 7,NSHIP
             PRINT 40
          40 FORMAT(IH0,25X,'DETAILED RESULTS--FUNCTIONAL GROUPING' )
             PRINT 45
          45 FORMAT(IH0,10X,'GROUP',4X,'NAME',4X,'WEIGHT',4X,'WT FRAC',4X,
1,VOLUME',4X,'VOL FRAC',5X,'DENSITY'/1H ,28X,'TONS',17X,'CU FT',
216X,'LBS/CU FT')
             PRINT 46,NCOMP(100),VWT(100),VWT(100)/WTSHIP,V(100),V(100)/VOLSHIP,
1FNDEN(100)
          46 FORMAT(IH0,10X,'100',4X,A8,F8.1,4X,F6.4,3X,F8.0,4X,F6.4,6X,F7.2/)
             DO 47 I=110,116
          47 PRINT 48,I,NCOMP(I),VWT(I),VWT(I)/WTSHIP,V(I),V(I)/VOLSHIP,FNDEN(I)
          48 FCRMAT(IH ,10X,I3,4X,A8,F8.1,4X,F6.4,3X,F8.0,4X,F6.4,6X,F7.2)
             PRINT 9
             DO 49 I=120,128

```

```

OUTPUT181
OUTPUT182
OUTPUT183
OUTPUT184
OUTPUT185
OUTPUT186
OUTPUT187
OUTPUT188
OUTPUT189
OUTPUT190
OUTPUT191
OUTPUT192
OUTPUT193
OUTPUT194
OUTPUT195
OUTPUT196
OUTPUT197
OUTPUT198
OUTPUT199
OUTPUT200
OUTPUT201
OUTPUT202
OUTPUT203
OUTPUT204
OUTPUT205
OUTPUT206
OUTPUT207
OUTPUT208
OUTPUT209
OUTPUT210
OUTPUT211
OUTPUT212
OUTPUT213
OUTPUT214
OUTPUT215
OUTPUT216

```

```

49 PRINT 48, I, NCOMP(I), VWT(I), VWT(I)/WTSHIP, V(I), V(I)/VOLSHIP, FNDEN(I)
   PRINT 9
   DO 50 I=130,135
50 PRINT 48, I, NCOMP(I), VWT(I), VWT(I)/WTSHIP, V(I), V(I)/VOLSHIP, FNDEN(I)
   PRINT 9
   DO 51 I=140,180,10
51 PRINT 48, I, NCOMP(I), VWT(I), VWT(I)/WTSHIP, V(I), V(I)/VOLSHIP, FNDEN(I)
   PRINT 9
   PRINT 52, NCOMP(200), VWT(200), VWT(200)/WTSHIP, V(200), V(200)/VOLSHIP,
   IFNDEN(200)
52 FORMAT(1H0,10X,'200',4X,A8,F8.1,4X,F6.4,3X,F8.0,4X,F6.4,6X,F7.2/)
   DO 53 I=210,219
53 PRINT 48, I, NCOMP(I), VWT(I), VWT(I)/WTSHIP, V(I), V(I)/VOLSHIP, FNDEN(I)
   PRINT 7, NSHIP
   PRINT 54
54 FORMAT(1H0,25X,'DETAILED RESULTS--FUNCTIONAL GROUPING CONTINUED')
   PRINT 45
   PRINT 9
   DO 55 I=220,226
55 PRINT 48, I, NCOMP(I), VWT(I), VWT(I)/WTSHIP, V(I), V(I)/VOLSHIP, FNDEN(I)
   PRINT 9
   DO 56 I=230,233
56 PRINT 48, I, NCOMP(I), VWT(I), VWT(I)/WTSHIP, V(I), V(I)/VOLSHIP, FNDEN(I)
   PRINT 9
   PRINT 57, NCOMP(300), VWT(300), VWT(300)/WTSHIP, V(300), V(300)/VOLSHIP,
   IFNDEN(300)
57 FORMAT(1H0,10X,'300',4X,A8,F8.1,4X,F6.4,3X,F8.0,4X,F6.4,6X,F7.2/)
   DO 58 I=310,313
58 PRINT 48, I, NCOMP(I), VWT(I), VWT(I)/WTSHIP, V(I), V(I)/VOLSHIP, FNDEN(I)
   PRINT 9
   DO 59 I=320,325
59 PRINT 48, I, NCOMP(I), VWT(I), VWT(I)/WTSHIP, V(I), V(I)/VOLSHIP, FNDEN(I)
   PRINT 9
   DO 60 I=330,332
60 PRINT 48, I, NCOMP(I), VWT(I), VWT(I)/WTSHIP, V(I), V(I)/VOLSHIP, FNDEN(I)
   PRINT 9

```

```

OUTP0217
OUTP0218
OUTP0219
OUTP0220
OUTP0221
OUTP0222
OUTP0223
OUTP0224
OUTP0225
OUTP0226
OUTP0227
OUTP0228
OUTP0229
OUTP0230
OUTP0231
OUTP0232
OUTP0233
OUTP0234
OUTP0235
OUTP0236
OUTP0237
OUTP0238
OUTP0239
OUTP0240
OUTP0241
OUTP0242
OUTP0243
OUTP0244
OUTP0245
OUTP0246
OUTP0247
OUTP0248
OUTP0249
OUTP0250
OUTP0251
OUTP0252

```

```

DO 61 I=340,343
61 PRINT 48,I,NCOMP(I),VWT(I),VWT(I)/WTSHIP,V(I),V(I)/VOLSHP,FNDEN(I)
   PRINT 9
DO 62 I=350,357
62 PRINT 48,I,NCOMP(I),VWT(I),VWT(I)/WTSHIP,V(I),V(I)/VOLSHP,FNDEN(I)
   PRINT 7,NSHIP
   PRINT 54
   PRINT 45
   PRINT 9
DO 63 I=360,365
63 PRINT 48,I,NCOMP(I),VWT(I),VWT(I)/WTSHIP,V(I),V(I)/VOLSHP,FNDEN(I)
   PRINT 9
DO 64 I=370,390,10
64 PRINT 48,I,NCOMP(I),VWT(I),VWT(I)/WTSHIP,V(I),V(I)/VOLSHP,FNDEN(I)
   PRINT 65,WFG4,WFG4/WTSHIP,WBHS,WRHS/WTSHIP,WSS,WSS/WTSHIP,WDHS,
1WDHS/WTSHIP,WARM,WARM/WTSHIP,WFFL,WFFL/WTSHIP,WFG5,WFG5/WTSHIP
65 FORMAT(1H0,10X,'400',4X,'HULL GRP',F8.1,4X,F6.4/1H0,10X,'410',4X,
1'BASCHULL',F8.1,4X,F6.4/1H 10X,'420',4X,'SEC HULL',F8.1,4X,F6.4/
21H 10X,'430',4X,'DECKHOUS',F8.1,4X,F6.4/1H 10X,'440',4X,'ARMOR',
33X,F8.1,4X,F6.4/1H 10X,'450',4X,'FREEFLQ',F8.1,4X,F6.4/1H0,10X,
4'500',4X,'SHIP SYS',F8.1,4X,F6.4/)
   PRINT 66,WTSHIP,WTSHIP/WTSHIP,VOLSHP,VOLSHP/VOLSHP,
12240.*WTSHIP/VOLSHP
66 FORMAT(1H0,17X,'TOTAL',3X,F8.1,4X,F6.4,3X,F8.0,4X,F6.4,6X,F7.2)
   PRINT DETAILED BSCI WT LISTING
   IF(PRTOUT.LT.2.) GO TO 200
   PRINT 7,NSHIP
   PRINT 67
67 FORMAT(1H0,17X,'DETAILED RESULTS--BSCI WEIGHT LISTING')
   PRINT 68
68 FORMAT(1H0,10X,'GROUP',4X,'NAME',4X,'WEIGHT',4X,
1'WT FRAC',4X,'WT FRAC',4X,'VCG'/1H 28X,'TONS',5X,'FULL LD',4X,
2'LITE SH',5X,'FT'/)
   DO 69 I=100,125
69 PRINT 70,I,NWT(I),W(I),W(I)/DISPFL,W(I)/DISPLS,VCG(I)
70 FORMAT(1H 10X,I3,4X,A8,F8.1,4X,F6.4,5X,F6.4,4X,F5.1)

```

C

```

DO 71 I=127,128
71 PRINT 70,I,NWT(I),W(I),W(I)/DISPFL,W(I)/DISPLS,VCG(I)
DO 72 I=150,151
72 PRINT 70,I,NWT(I),W(I),W(I)/DISPFL,W(I)/DISPLS,VCG(I)
PRINT 73,WTGP1,WTGP1/DISPFL,WTGP1/DISPLS,CG1
73 FORMAT(1H,17X,'GRP1 TOT',F8.1,4X,F6.4,5X,F6.4,4X,F5.1/)
DO 74 I=200,211
74 PRINT 70,I,NWT(I),W(I),W(I)/DISPFL,W(I)/DISPLS,VCG(I)
DO 75 I=250,251
75 PRINT 70,I,NWT(I),W(I),W(I)/DISPFL,W(I)/DISPLS,VCG(I)
PRINT 76,WTGP2,WTGP2/DISPFL,WTGP2/DISPLS,CG2
76 FORMAT(1H,17X,'GRP2 TOT',F8.1,4X,F6.4,5X,F6.4,4X,F5.1/)
PRINT 7,NSHIP
PRINT 77
77 FORMAT(1H0,17X,'DETAILED RESULTS--8SCI WEIGHT LISTING CONTINUED')
PRINT 68
DO 78 I=300,303
78 PRINT 70,I,NWT(I),W(I),W(I)/DISPFL,W(I)/DISPLS,VCG(I)
DO 79 I=350,351
79 PRINT 70,I,NWT(I),W(I),W(I)/DISPFL,W(I)/DISPLS,VCG(I)
PRINT 80,WTGP3,WTGP3/DISPFL,WTGP3/DISPLS,CG3
80 FORMAT(1H,17X,'GRP3 TOT',F8.1,4X,F6.4,5X,F6.4,4X,F5.1/)
DO 81 I=400,413
81 PRINT 70,I,NWT(I),W(I),W(I)/DISPFL,W(I)/DISPLS,VCG(I)
I=415
PRINT 70,I,NWT(I),W(I),W(I)/DISPFL,W(I)/DISPLS,VCG(I)
DO 82 I=450,451
82 PRINT 70,I,NWT(I),W(I),W(I)/DISPFL,W(I)/DISPLS,VCG(I)
PRINT 83,WTGP4,WTGP4/DISPFL,WTGP4/DISPLS,CG4
83 FORMAT(1H,17X,'GRP4 TOT',F8.1,4X,F6.4,5X,F6.4,4X,F5.1/)
DO 84 I=500,520
84 PRINT 70,I,NWT(I),W(I),W(I)/DISPFL,W(I)/DISPLS,VCG(I)
PRINT 7,NSHIP
PRINT 77
PRINT 68
DO 85 I=521,528

```

```

OUTP0289
OUTP0290
OUTP0291
OUTP0292
OUTP0293
OUTP0294
OUTP0295
OUTP0296
OUTP0297
OUTP0298
OUTP0299
OUTP0300
OUTP0301
OUTP0302
OUTP0303
OUTP0304
OUTP0305
OUTP0306
OUTP0307
OUTP0308
OUTP0309
OUTP0310
OUTP0311
OUTP0312
OUTP0313
OUTP0314
OUTP0315
OUTP0316
OUTP0317
OUTP0318
OUTP0319
OUTP0320
OUTP0321
OUTP0322
OUTP0323
OUTP0324

```

```

85 PRINT 70,I,NWT(I),W(I),W(I)/DISPFL,W(I)/DISPFL,W(I)/DISPFL,VCG(I)
DO 86 I=550,551
86 PRINT 70,I,NWT(I),W(I),W(I)/DISPFL,W(I)/DISPFL,W(I)/DISPFL,VCG(I)
PRINT 87,WTGP5,WTGP5/DISPFL,WTGP5/DISPFL,CG5
87 FORMAT(1H,17X,'GRP5 TOT',F8.1,4X,F6.4,5X,F6.4,4X,F5.1/)
DO 88 I=600,615
88 PRINT 70,I,NWT(I),W(I),W(I)/DISPFL,W(I)/DISPFL,W(I)/DISPFL,VCG(I)
DO 89 I=650,651
89 PRINT 70,I,NWT(I),W(I),W(I)/DISPFL,W(I)/DISPFL,W(I)/DISPFL,VCG(I)
PRINT 90,WTGP6,WTGP6/DISPFL,WTGP6/DISPFL,CG6
90 FORMAT(1H,17X,'GRP6 TOT',F8.1,4X,F6.4,5X,F6.4,4X,F5.1/)
DO 91 I=700,713
91 PRINT 70,I,NWT(I),W(I),W(I)/DISPFL,W(I)/DISPFL,W(I)/DISPFL,VCG(I)
I=720
PRINT 70,I,NWT(I),W(I),W(I)/DISPFL,W(I)/DISPFL,W(I)/DISPFL,VCG(I)
DO 92 I=750,751
92 PRINT 70,I,NWT(I),W(I),W(I)/DISPFL,W(I)/DISPFL,W(I)/DISPFL,VCG(I)
PRINT 93,WTGP7,WTGP7/DISPFL,WTGP7/DISPFL,CG7
93 FORMAT(1H,17X,'GRP7 TOT',F8.1,4X,F6.4,5X,F6.4,4X,F5.1/)
PRINT 7,NSHIP
PRINT 77
PRINT 94
94 FORMAT(1H0,10X,'GROUP',4X,'NAME',4X,'WEIGHT',4X,'WT FRAC',4X,
1,VCG'/1H,28X,'TONS',5X,'FULL LD',5X,'FT'/)
DO 95 I=800,822
95 PRINT 96,I,NWT(I),W(I),W(I)/DISPFL,VCG(I)
96 FORMAT(1H,10X,I3,4X,A8,F8.1,4X,F6.4,4X,F5.1)
PRINT 97,VRLOAD,VRLOAD/DISPFL,CGLDS,DISPFL,DISPFL/DISPFL,CGLSP,
1WTMARG,WTMARG/DISPFL,VCG(825),DISPFL,DISPFL/DISPFL,CGFLD
97 FORMAT(1H0,15X,'VRLOAD TOT',F8.1,4X,F6.4,4X,F5.1/1H,15X,
1,LIGHT SHIP',F8.1,4X,F6.4,4X,F5.1/1H,16X,'WT MARGIN',F8.1,4X,
2F6.4,4X,F5.1/1H0,11X,'FULL LOAD DISP',F8.1,4X,F6.4,4X,F5.1)
PRINT FUNCTIONAL ELECTRIC LOADS
PRINT 98
98 FORMAT(1H-,25X,'DETAILED RESULTS--FUNCTIONAL ELECTRIC LOADS')
PRINT 99

```

C

```

99 FORMAT(1H0,10X,'GROUP',4X,'NAME',4X,'CRUISE KW',4X,'BATTLE KW',
14X,'24 HR AVG KW',7)
DO 100 I=100,900,100
100 PRINT 101,I,NELC(I/100),ECR(I/100),EBT(I/100),EAV(I/100)
101 FORMAT(1H,10X,I3,4X,A8,2X,F7.1,6X,F7.1,8X,F7.1)
PRINT 102,NELC(10),ECR(10),EBT(10),EAV(10),NELC(11),ECR(11),
1EBT(11),EAV(11)
102 FORMAT(1H,17X,A8,2X,F7.1,6X,F7.1,8X,F7.1/1H0,17X,A8,2X,F7.1,6X,
1F7.1,8X,F7.1)
200 RETURN
END
OUTPUT361
OUTPUT362
OUTPUT363
OUTPUT364
OUTPUT365
OUTPUT366
OUTPUT367
OUTPUT368
OUTPUT369
OUTPUT370
OUTPUT371

```

VSUS	VEND	RANGE	LBP	L/B	B/H	CP	CX	NAME0001									
PROP	PLTSUS	SHP	NU	BOILSNU	REACTNU	ENGS	NU	SHAFTPROPELLRSHFT	TYPPROP	RPMPROP	DIA	NAME0002					
DEPTH	MBLENTH	M3BEAM	M3	PC	END	PC	MAXSPDELTA	CF	NAME0003			NAME0004					
SSEL	TYPPEMEL	TYPNU	LOWSDNU	MEDSDNU	HI	SDNU	GT	GGNU	ST	GNKW/DIESLKW/GAS	TKW/STM	G	NAME0005				
ELC	MARG									HEAT	TYPFIN	STAB	NAME0006				
CPO	ACC	CREW	ACCFLAG	ACCTRP	ACC	PASS	ACCDAYS	DUR		DISP	TOLMXDIS	ITVCG	TOL	MXVCG	ITDCWTMARG	NAME0007	
HULL	MATSUPSTMAT					GM/B	MIN			PASSAGE	PROP	PLTSEL	TYPPEMEL	TYP		NAME0008	
FS	CORR	PRNT	TYPPRNTCNST							HULL	MATSUPSTMAT	PASSAGE				NAME0009	
SHFT	TYPPROPELLRFIN	STABHEAT	TYP													NAME0010	
GASTURB2DIESEL	COGAS	STEAM						600	STM	I200	STMPFI200STNUCLEAR	GASTURB1				NAME0011	
SOLID	FIXEDPITCONT	PITNO	YES	STEAM	ELECTRIC	STEEL	ALUMINUM	CNTRL	LINE							NAME0012	
PORTSTBD																NAME0013	
LBP	BEAM	DRAFT	D	0	D	10	D	20	D	AVG	LEN	R	DKCP	CX		NAME0014	
VCG	FLD	VCG/DAVGL/B	B/H	EXCES	KGRANGE	SUS	SHP	END	SHP	VSUS	VEND					NAME0015	
AVSEASP	DNNU	ACCOMKW	INST	KW	SPSERKW	EMERGDISP	FLDDISP	LSPVR	LOADSMT	MARG	WTGRP	1				NAME0016	
WTGRP	2	WTGRP	3	WTGRP	4	WTGRP	5	WTGRP	6	WTGRP	7	VOL	TOT	VOL	HULLVOL	SSTRUCRUISEKW	NAME0017
BATTLE	KW24	HR	KWNU	LOWSDNU	MEDSDNU	HI	SDNU	GT	GGNU	ST	GNKW/DIESLKW/GAS	TKW/STM	G			NAME0018	
FLD	DENSLSP	DENSWPAY/FLDWPER/FLDWOPS/FLDVHAB/MANWHAB/MANMEN/DISPKWIN/FLDSHP/DISDPD*V/SHPWPY*V/DP															NAME0019
MIL	MISS																NAME0020
COMM/DETRADIOCOMRADAR	SONAR	ECM	EVALUATEC/D	SUPP													NAME0021
WEAPONS	GUNS	MISSILESASW	MINE	WARSM	ARMS	CM	NO	ELWEAP	SUPSPECWEAP								NAME0022
AVIATIONCONTROL	STOW/MNT	STORES	LIQUIDS	ORDNANCE													NAME0023
AMPH	OPS																NAME0024
CARGO																	NAME0025
FLAG																	NAME0026
PASSNGER																	NAME0027
SPEC	MIS																NAME0028
PERSONEL																	NAME0029
LIVING	OFF	BER	OFF	MESSOFF	BATHCPO	BER	CPO	MESSCPO	BATHCREW	BERCREWMESS	SCREWBATH						NAME0030
SUPPORT	ADMIN	FNFOOD	P&H	MED	&DENPER	SERVREC	&WELSEWAGE										NAME0031
STOWAGE	STORES	PER	STOWPOT	WATER													NAME0032
																	NAME0033
																	NAME0034
																	NAME0035
																	NAME0036

NAME0037
 NAME0038
 NAME0039
 NAME0040
 NAME0041
 NAME0042
 NAME0043
 NAME0044
 NAME0045
 NAME0046
 NAME0047
 NAME0048
 NAME0049
 NAME0050
 NAME0051
 NAME0052
 NAME0053
 NAME0054
 NAME0055
 NAME0056
 NAME0057
 NAME0058
 NAME0059
 NAME0060
 NAME0061
 NAME0062
 NAME0063
 NAME0064
 NAME0065
 NAME0066
 NAME0067
 NAME0068
 NAME0069
 NAME0070
 NAME0071
 NAME0072

SHIP OPS
 CONTROL SHIP CNTDAM CONTOFFICES
 MACH SYSMACH BOXUPTAKES SH,BR,PRMANEUVERVENTILAT
 DECK AUXANCH,M&TUNREP
 MAINTAINMECHANICELECTRICMISC
 STOWAGE FUEL OILR FEED WLUBE OILDIES OILMISC LIQSTOR&SUPBOATS
 TANKAGE BALLAST PEAK VOIDS XFLOODNGMISC TNK
 PASS&ACC
 HULL MAR
 SUP MARG
 PLATING FRAMING INN BOTMPLATFLAT ALL DECK
 SUPERSTRPROP FNDAUX FNDSSSTR BKHDTRK&ENCLSTR SPONARMOR AC T STRCAST&FOR
 SEACHESTBAL UNITSPEC DRSDRS&HTCH MASTKGPT SONAR DMTOWRPLAT

 WELDRIVTFREEFLIQ

 BOIL&CONPROPUNITMN CONDSSH,BR,PRCOMB AIRUPTAKES PROP CNTMN STM SFW&CONDNCIRC&CWS
 FOSERSYSLBOILSYS

 REPAIRPTOPER FLD

 EL PWGENPOW SWBDCABLE LIGHTING

NAME0073
 NAME0074
 NAME0075
 NAME0076
 NAME0077
 NAME0078
 NAME0079
 NAME0080
 NAME0081
 NAME0082
 NAME0083
 NAME0084
 NAME0085
 NAME0086
 NAME0087
 NAME0088
 NAME0089
 NAME0090
 NAME0091
 NAME0092
 NAME0093
 NAME0094
 NAME0095
 NAME0096
 NAME0097
 NAME0098
 NAME0099
 NAME0100
 NAME0101
 NAME0102
 NAME0103
 NAME0104
 NAME0105
 NAME0106
 NAME0107
 NAME0108

REPAIRPTGEN FLDS

NAV EQUIP SYSYSGFC SYSTEM NO ELEGM MFC SYS ASW FCS TORP FCSRADAR RADIOCOM
 ELEC NAVSPACTRCKSONAR ELEC TDS ELECTEST

REPAIRPTCC OPFLD

HEAT SYSVENT SYSAIR CONDREFER PLHEAF,ETCPLUMBINGFIREMAINFIRE EXTBALSTYSFRESHWAT
 SCUPPERSFUELTRANTANKHEATCOMP AIRAUX STM BUOY CNTMISCIPIEDISTILLGSTEERINGRUDDERS
 ANCH,M&TSTOR EQPELOPGEARAIR ELEVACARGEARCATS&JBDHYDROFLSSTAB FINUNREP

REPAIRPTAUX FLDS

HULL FITBOATS RIG&CANVLAD&GRATNONS B&DPAINTINGDK COVERHULL INSSTORERMSUTIL EQP
 WKSP EQPGALY EQPLIV FURNOFF FURNM&D FURNRAD SHLD

REPAIRPTO&F FLDS

NAME0109
NAME0110
NAME0111
NAME0112
NAME0113
NAME0114
NAME0115
NAME0116
NAME0117
NAME0118
NAME0119
NAME0120
NAME0121
NAME0122
NAME0123
NAME0124
NAME0125
NAME0126

TORPTH&S

SPWEPH&SMIS LH&S

GUN MNTS
MINE H&SSM ARMS AIR H&ST
CARGOH&S

REPAIRPTARM FLDS

SHIP OCETRPS&EFFPASS&EFFSHIPAMMOAV AMMO AIRCRAFTPROV&PSTGEN STORMARINESTAERO STR
ORDSTRSHORDSTRAVPOTWATERR FEED WLUBOILSHLUBOILAVFUEL OILDIES OILGASOLINEJP-5
MISC LIQCARGO BALL WAT D&C MARG
PA&STEERAUX MACHDECKMACHSHOPS IC&ELEX ORDN SYSHOTEL A/C&VENTPWR CONVELECMARG
TOTAL KW

.21	.21	.21	.21	.21	.29	.60	1.15	1.77	2.19	2.38	2.40	2.38	2.30	2.20	2.10	CRVS0001	
.20	.20	.20	.20	.20	.25	.49	.97	1.55	1.94	2.13	2.20	2.18	2.11	2.03	1.92	CRVS0002	
.20	.20	.21	.21	.22	.26	.46	.88	1.38	1.73	1.91	2.00	2.00	1.98	1.91	1.86	CRVS0003	
.22	.22	.22	.22	.22	.26	.37	.75	1.20	1.57	1.8	1.88	1.89	1.85	1.79	1.70	CRVS0004	
.22	.22	.22	.22	.22	.30	.40	.71	1.12	1.47	1.68	1.75	1.77	1.73	1.68	1.60	CRVS0005	
.22	.22	.22	.22	.22	.38	.41	.65	1.06	1.43	1.63	1.71	1.72	1.70	1.66	1.59	CRVS0006	
.23	.23	.23	.23	.25	.45	.48	.65	1.03	1.37	1.57	1.66	1.69	1.68	1.62	1.56	CRVS0007	
.23	.23	.23	.23	.24	.54	.59	.73	1.07	1.37	1.54	1.64	1.67	1.66	1.60	1.53	CRVS0008	
.23	.23	.23	.23	.27	.70	.74	.80	1.10	1.38	1.54	1.63	1.68	1.67	1.60	1.52	CRVS0009	
.24	.24	.24	.24	.30	.82	.88	.88	1.15	1.40	1.56	1.63	1.66	1.63	1.60	1.52	CRVS0010	
.23	.23	.23	.23	.33	.94	1.05	.98	1.19	1.41	1.55	1.63	1.67	1.65	1.60	1.55	CRVS0011	
.24	.24	.24	.24	.40	1.11	1.21	1.13	1.28	1.43	1.57	1.63	1.65	1.65	1.60	1.56	CRVS0012	
.25	.25	.26	.26	.35	.41	.47	1.03	2.23	3.73	4.84	5.40	5.53	5.51	5.39	5.07	4.53	CRVS0013
.25	.27	.28	.28	.31	.38	.43	.89	1.90	3.29	4.43	5.05	5.25	5.26	5.12	4.83	4.37	CRVS0014
.26	.26	.27	.27	.30	.37	.42	.82	1.74	3.00	4.16	4.80	5.02	5.05	4.90	4.60	4.22	CRVS0015
.28	.28	.28	.28	.30	.40	.47	.73	1.54	2.71	3.84	4.55	4.80	4.80	4.68	4.40	4.10	CRVS0016
.28	.28	.28	.28	.30	.45	.60	.78	1.45	2.55	3.65	4.33	4.58	4.60	4.48	4.24	3.92	CRVS0017
.28	.28	.28	.28	.32	.51	.77	.88	1.40	2.45	3.48	4.12	4.38	4.39	4.30	4.10	3.85	CRVS0018
.28	.28	.28	.28	.37	.59	.75	1.03	1.41	2.34	3.33	3.90	4.17	4.20	4.13	3.95	3.80	CRVS0019
.28	.28	.28	.28	.40	.68	.84	1.20	1.54	2.38	3.28	3.81	4.04	4.10	4.02	3.86	3.62	CRVS0020
.30	.30	.30	.30	.43	.77	1.48	1.49	1.70	2.41	3.19	3.73	3.97	3.99	3.95	3.81	3.60	CRVS0021
.28	.29	.32	.51	.89	1.72	1.83	1.89	2.46	3.23	3.69	3.90	3.95	3.90	3.79	3.64	CRVS0022	
.28	.28	.32	.60	.98	1.97	2.10	2.07	2.52	3.24	3.68	3.87	3.92	3.89	3.78	3.61	CRVS0023	
.30	.30	.37	.70	1.11	2.22	2.44	2.28	2.64	3.30	3.68	3.87	3.93	3.90	3.77	3.60	CRVS0024	
.25	.25	.25	.27	.28	.34	.66	1.20	1.73	2.18	2.40	2.45	2.44	2.39	2.30	2.17	CRVS0025	
.25	.25	.25	.32	.38	.42	.69	1.10	1.60	2.06	2.28	2.35	2.32	2.25	2.17	2.11	CRVS0026	
.26	.26	.27	.39	.46	.48	.66	1.02	1.46	1.94	2.13	2.17	2.17	2.13	2.08	2.00	CRVS0027	
.27	.27	.27	.40	.51	.51	.69	.97	1.38	1.83	2.03	2.10	2.09	2.04	1.96	1.93	CRVS0028	
.28	.28	.28	.42	.57	.62	.67	.88	1.32	1.71	1.90	1.96	1.97	1.95	1.90	1.86	CRVS0029	
.30	.30	.30	.43	.58	.68	.71	.89	1.29	1.63	1.81	1.90	1.92	1.90	1.86	1.80	CRVS0030	
.30	.30	.31	.45	.59	.70	.76	.90	1.23	1.58	1.77	1.83	1.87	1.85	1.80	1.73	CRVS0031	
.30	.31	.32	.42	.60	.77	.81	.90	1.20	1.54	1.72	1.79	1.80	1.80	1.74	1.70	CRVS0032	
.33	.33	.33	.40	.62	.85	.90	.95	1.19	1.50	1.70	1.75	1.76	1.74	1.70	1.65	CRVS0033	
.35	.35	.36	.40	.63	.90	1.00	1.02	1.25	1.53	1.67	1.75	1.77	1.76	1.70	1.63	CRVS0034	
.34	.34	.35	.40	.64	1.05	1.17	1.12	1.25	1.53	1.69	1.74	1.76	1.75	1.70	1.62	CRVS0035	
.35	.35	.36	.40	.65	1.20	1.37	1.22	1.25	1.53	1.68	1.74	1.76	1.75	1.70	1.61	CRVS0036	

.29	.30	.32	.50	.57	.60	1.13	2.19	3.60	4.90	5.56	5.80	5.76	5.57	5.25	5.05	CRVS0037
.30	.30	.31	.51	.62	.60	1.04	1.93	3.29	4.57	5.31	5.50	5.50	5.40	5.20	4.80	CRVS0038
.33	.33	.33	.52	.66	.66	.97	1.75	3.06	4.27	5.00	5.30	5.30	5.25	5.10	4.90	CRVS0039
.32	.32	.33	.52	.68	.71	.96	1.61	2.80	4.04	4.72	5.00	5.00	5.00	4.80	4.70	CRVS0040
.34	.34	.34	.54	.73	.82	1.00	1.60	2.68	3.80	4.42	4.71	4.80	4.77	4.64	4.40	CRVS0041
.34	.34	.37	.55	.78	.98	1.15	1.65	2.57	3.62	4.26	4.40	4.50	4.50	4.40	4.20	CRVS0042
.37	.38	.40	.57	.83	1.17	1.34	1.70	2.55	3.52	4.17	4.45	4.50	4.55	4.50	4.30	CRVS0043
.38	.38	.40	.58	.88	1.35	1.60	1.85	2.55	3.46	4.08	4.34	4.42	4.42	4.35	4.20	CRVS0044
.38	.38	.41	.59	.94	1.60	1.85	2.02	2.54	3.40	4.05	4.41	4.55	4.50	4.30	4.00	CRVS0045
.40	.40	.48	.63	1.02	1.82	2.07	2.21	2.70	3.44	4.03	4.27	4.35	4.25	4.10	3.80	CRVS0046
.40	.40	.48	.70	1.11	2.07	2.40	2.45	2.80	3.48	4.04	4.28	4.35	4.30	4.10	3.80	CRVS0047
.41	.41	.54	.80	1.24	2.30	2.70	2.71	2.98	3.60	4.05	4.26	4.32	4.30	4.10	3.80	CRVS0048
.30	.30	.30	.41	.48	.47	.64	1.20	1.87	2.35	2.68	2.80	2.80	2.76	2.70	2.60	CRVS0049
.33	.33	.33	.42	.48	.47	.65	1.09	1.63	2.13	2.45	2.59	2.60	2.58	2.50	2.40	CRVS0050
.35	.35	.35	.43	.46	.44	.59	.93	1.48	2.01	2.26	2.37	2.39	2.37	2.31	2.24	CRVS0051
.37	.37	.37	.41	.47	.45	.58	.87	1.34	1.82	2.06	2.17	2.20	2.20	2.13	2.06	CRVS0052
.40	.40	.40	.43	.48	.49	.59	.82	1.24	1.65	1.90	2.00	2.06	2.05	2.00	1.91	CRVS0053
.40	.40	.40	.42	.48	.54	.63	.83	1.23	1.60	1.80	1.93	1.97	1.97	1.91	1.78	CRVS0054
.42	.42	.42	.45	.52	.61	.73	.81	1.18	1.53	1.74	1.87	1.93	1.90	1.85	1.73	CRVS0055
.42	.42	.42	.44	.54	.69	.81	.90	1.16	1.53	1.77	1.89	1.90	1.89	1.80	1.70	CRVS0056
.45	.45	.45	.50	.58	.80	.93	1.00	1.18	1.52	1.73	1.83	1.88	1.85	1.78	1.69	CRVS0057
.47	.47	.47	.56	.67	.90	1.05	1.09	1.23	1.53	1.74	1.85	1.88	1.84	1.77	1.67	CRVS0058
.48	.48	.48	.62	.70	1.00	1.20	1.20	1.30	1.52	1.71	1.85	1.87	1.82	1.74	1.69	CRVS0059
.49	.49	.49	.68	.73	1.10	1.34	1.33	1.37	1.52	1.71	1.84	1.87	1.80	1.72	1.70	CRVS0060
.35	.35	.40	.53	.67	.65	1.13	2.30	3.72	5.00	5.95	6.40	6.50	6.40	6.10	5.50	CRVS0061
.38	.38	.42	.54	.65	.63	1.00	1.95	3.40	4.67	5.50	5.80	5.90	5.80	5.50	5.10	CRVS0062
.41	.41	.43	.53	.60	.63	.89	1.78	3.10	4.33	5.10	5.35	5.40	5.30	5.10	4.90	CRVS0063
.43	.43	.45	.53	.64	.70	.91	1.70	2.90	4.07	4.79	5.00	5.10	5.10	4.90	4.70	CRVS0064
.45	.45	.45	.53	.68	.81	.97	1.62	2.73	3.87	4.60	4.95	5.10	5.00	4.90	4.60	CRVS0065
.45	.45	.47	.53	.72	.91	1.15	1.59	2.62	3.75	4.48	4.90	5.00	5.00	4.90	4.50	CRVS0066
.48	.49	.50	.56	.78	1.10	1.35	1.78	2.64	3.70	4.40	4.74	4.80	4.75	4.60	4.25	CRVS0067
.48	.48	.50	.56	.84	1.30	1.60	1.92	2.63	3.65	4.34	4.65	4.70	4.58	4.40	4.10	CRVS0068
.52	.52	.53	.63	.93	1.53	1.85	2.13	2.77	3.63	4.29	4.61	4.70	4.55	4.35	4.00	CRVS0069
.53	.54	.56	.70	1.01	1.78	2.10	2.32	2.85	3.61	4.24	4.55	4.60	4.50	4.25	3.90	CRVS0070
.55	.55	.58	.79	1.16	2.05	2.40	2.57	3.00	3.67	4.23	4.53	4.55	4.40	4.10	3.80	CRVS0071
.58	.58	.66	.90	1.30	2.30	2.73	2.83	3.20	3.70	4.22	4.50	4.45	4.25	4.00	3.70	CRVS0072

.31	.31	.33	.50	.57	.64	1.50	3.40	5.65	CRVS0073
.31	.31	.34	.43	.52	.60	1.20	1.80	5.10	CRVS0074
.30	.30	.32	.38	.48	.60	1.12	2.60	4.60	CRVS0075
.33	.33	.34	.39	.52	.78	1.07	2.23	4.17	CRVS0076
.33	.33	.35	.40	.58	.86	1.13	2.10	3.90	CRVS0077
.34	.34	.34	.42	.67	1.14	1.30	2.05	3.83	CRVS0078
.34	.34	.35	.46	.79	1.45	1.55	2.10	3.67	CRVS0079
.34	.34	.37	.50	.89	1.76	1.84	2.26	3.65	CRVS0080
.34	.34	.38	.57	1.00	2.09	2.23	2.50	3.68	CRVS0081
.33	.33	.40	.65	1.15	2.43	2.69	2.82	3.80	CRVS0082
.34	.34	.41	.74	1.29	2.75	3.18	3.18	3.90	CRVS0083
.35	.36	.47	.85	1.45	3.12	3.76	3.63	4.10	CRVS0084
.35	.35	.40	.60	.72	.85	2.00	4.70	7.70	CRVS0085
.35	.36	.39	.50	.60	.74	1.54	3.65	7.00	CRVS0086
.35	.35	.38	.46	.57	.73	1.37	3.30	6.30	CRVS0087
.38	.38	.40	.47	.61	.83	1.37	2.85	5.70	CRVS0088
.38	.38	.40	.48	.70	1.10	1.49	2.72	4.32	CRVS0089
.38	.38	.40	.51	.83	1.45	1.70	2.65	5.20	CRVS0090
.38	.38	.42	.55	.97	1.80	2.00	2.70	4.00	CRVS0091
.39	.39	.43	.62	1.10	2.18	2.43	2.97	5.10	CRVS0092
.40	.40	.46	.69	1.20	2.62	2.95	3.30	5.00	CRVS0093
.40	.40	.48	.77	1.40	3.07	3.56	3.73	5.15	CRVS0094
.40	.40	.50	.86	1.55	3.50	4.23	4.23	5.30	CRVS0095
.40	.42	.57	.98	1.71	4.00	5.03	4.89	5.60	CRVS0096
.40	.41	.48	.70	.88	1.10	2.60	6.00	9.70	CRVS0097
.42	.42	.46	.60	.72	.90	1.90	4.45	9.00	CRVS0098
.42	.42	.43	.52	.67	.83	1.60	4.15	8.10	CRVS0099
.42	.42	.45	.52	.70	.94	1.57	3.80	7.20	CRVS0100
.43	.43	.46	.55	.71	1.26	1.73	3.40	6.80	CRVS0101
.44	.44	.48	.58	.95	1.70	2.00	3.45	6.50	CRVS0102
.45	.45	.50	.63	1.10	2.11	2.45	3.33	6.35	CRVS0103
.45	.45	.50	.70	1.26	2.63	3.05	3.64	6.15	CRVS0104
.47	.47	.53	.78	1.40	3.10	3.70	4.10	5.30	CRVS0105
.46	.48	.57	.86	1.58	3.70	4.46	4.64	6.40	CRVS0106
.45	.46	.58	.95	1.75	4.20	5.33	5.28	6.80	CRVS0107
.47	.49	.68	1.08	1.93	4.90	6.30	6.00	7.05	CRVS0108

.36	.36	.37	.66	.78	.86	1.60	3.40	6.10	CRVS0109
.35	.35	.38	.62	.76	.82	1.40	2.90	5.10	CRVS0110
.38	.38	.39	.60	.77	.81	1.25	2.55	4.75	CRVS0111
.38	.38	.40	.60	.78	.84	1.23	2.45	4.45	CRVS0112
.40	.40	.42	.60	.82	1.00	1.30	2.34	4.20	CRVS0113
.40	.40	.43	.62	.89	1.25	1.50	2.36	3.97	CRVS0114
.42	.42	.44	.64	.99	1.52	1.80	2.50	3.83	CRVS0115
.44	.44	.47	.68	1.08	1.83	2.20	2.70	3.90	CRVS0116
.43	.43	.49	.72	1.20	2.17	2.63	3.01	3.98	CRVS0117
.45	.46	.55	.79	1.35	2.50	3.05	3.34	4.20	CRVS0118
.46	.46	.58	.94	1.50	2.85	3.54	3.75	4.45	CRVS0119
.48	.49	.67	1.07	1.65	3.24	4.04	4.18	4.80	CRVS0120
.41	.41	.45	.76	.95	1.07	2.07	4.75	9.20	CRVS0121
.42	.42	.45	.72	.86	.98	1.80	3.95	7.00	CRVS0122
.44	.44	.47	.68	.83	.96	1.58	3.50	6.50	CRVS0123
.43	.43	.47	.65	.82	.97	1.52	3.13	6.20	CRVS0124
.44	.45	.48	.64	.89	1.15	1.58	3.00	5.54	CRVS0125
.47	.47	.50	.66	.95	1.48	1.83	2.94	5.20	CRVS0126
.47	.47	.52	.70	1.05	1.83	2.36	3.12	5.03	CRVS0127
.50	.50	.54	.73	1.18	2.20	2.77	3.44	5.32	CRVS0128
.50	.51	.58	.80	1.37	2.67	3.30	3.80	5.40	CRVS0129
.53	.53	.62	.89	1.50	3.10	3.90	4.27	5.70	CRVS0130
.53	.53	.68	1.04	1.73	3.55	4.62	4.90	6.17	CRVS0131
.55	.56	.78	1.22	1.90	4.00	5.30	5.60	6.60	CRVS0132
.47	.47	.53	.87	1.10	1.29	2.73	6.10	12.00	CRVS0133
.48	.48	.52	.81	.97	1.17	2.25	4.90	9.00	CRVS0134
.50	.50	.54	.75	.90	1.08	1.90	4.50	8.20	CRVS0135
.52	.52	.54	.72	.87	1.07	1.80	3.80	7.50	CRVS0136
.52	.52	.56	.70	.93	1.25	1.87	3.60	6.70	CRVS0137
.53	.53	.57	.73	1.01	1.69	2.21	3.45	6.25	CRVS0138
.55	.55	.58	.76	1.13	2.13	2.74	3.65	6.10	CRVS0139
.53	.53	.62	.80	1.28	2.58	3.32	4.04	6.75	CRVS0140
.56	.57	.66	.87	1.46	3.09	3.94	4.55	6.80	CRVS0141
.58	.58	.73	.96	1.63	3.60	4.74	5.17	7.20	CRVS0142
.58	.58	.77	1.10	1.84	4.17	5.74	5.95	7.90	CRVS0143
.60	.62	.88	1.31	2.07	4.70	6.45	7.05	8.40	CRVS0144

.42	.42	.49	.70	.88	.95	1.68	3.43	6.00	CRVS0145
.46	.46	.50	.67	.81	.88	1.42	2.91	5.40	CRVS0146
.46	.46	.51	.66	.77	.85	1.30	2.65	4.95	CRVS0147
.50	.50	.54	.67	.77	.96	1.28	2.44	4.45	CRVS0148
.50	.50	.53	.64	.81	1.08	1.38	2.33	4.10	CRVS0149
.52	.52	.54	.63	.88	1.24	1.60	2.45	4.05	CRVS0150
.53	.55	.57	.65	.97	1.47	1.87	2.53	4.10	CRVS0151
.53	.53	.58	.66	1.08	1.75	2.25	2.90	4.15	CRVS0152
.58	.58	.62	.73	1.24	2.10	2.65	3.17	4.30	CRVS0153
.60	.60	.67	.84	1.31	2.48	3.10	3.53	4.50	CRVS0154
.62	.62	.68	.95	1.48	2.86	3.60	3.96	4.73	CRVS0155
.63	.63	.77	1.10	1.64	3.27	4.13	4.38	5.07	CRVS0156
.48	.50	.56	.84	1.09	1.28	2.20	4.63	8.20	CRVS0157
.52	.52	.60	.82	.99	1.16	1.90	4.10	7.10	CRVS0158
.55	.55	.59	.78	.92	1.10	1.72	3.61	6.50	CRVS0159
.55	.55	.61	.80	.92	1.18	1.68	3.30	5.95	CRVS0160
.57	.57	.62	.73	.96	1.33	1.77	3.10	5.50	CRVS0161
.58	.58	.62	.73	1.01	1.51	2.05	3.13	5.30	CRVS0162
.62	.60	.65	.76	1.11	1.76	2.40	3.30	5.20	CRVS0163
.62	.62	.68	.78	1.25	2.10	2.80	3.60	5.30	CRVS0164
.65	.65	.73	.85	1.40	2.50	3.30	3.98	5.55	CRVS0165
.67	.67	.76	.96	1.58	2.95	3.83	4.44	5.80	CRVS0166
.67	.67	.80	1.09	1.75	3.45	4.43	5.00	6.15	CRVS0167
.72	.71	.85	1.23	1.94	3.90	5.15	5.63	6.54	CRVS0168
.55	.56	.65	1.00	1.32	1.60	2.86	5.90	10.40	CRVS0169
.58	.58	.65	.94	1.16	1.35	2.48	5.15	8.80	CRVS0170
.61	.60	.67	.90	1.07	1.30	2.20	4.50	7.90	CRVS0171
.62	.62	.70	.87	1.05	1.36	2.10	4.05	7.40	CRVS0172
.64	.64	.70	.83	1.10	1.53	2.18	3.80	6.90	CRVS0173
.64	.64	.73	.81	1.15	1.79	2.43	3.80	6.50	CRVS0174
.68	.70	.75	.87	1.25	2.13	2.85	3.90	6.30	CRVS0175
.68	.68	.77	.87	1.37	2.55	3.35	4.27	6.20	CRVS0176
.70	.72	.82	.98	1.57	3.05	3.98	4.80	6.50	CRVS0177
.73	.73	.84	1.09	1.77	3.60	4.65	5.30	6.80	CRVS0178
.74	.75	.90	1.20	2.00	4.10	5.35	5.90	7.20	CRVS0179
.77	.77	.95	1.34	2.20	4.30	5.85	6.40	8.6	CRVS0180

CRVS0181
CRVS0182
CRVS0183
CRVS0184
CRVS0185
CRVS0186
CRVS0187
CRVS0188
CRVS0189
CRVS0190
CRVS0191
CRVS0192
CRVS0193
CRVS0194
CRVS0195
CRVS0196
CRVS0197
CRVS0198
CRVS0199
CRVS0200
CRVS0201
CRVS0202
CRVS0203
CRVS0204
CRVS0205
CRVS0206
CRVS0207
CRVS0208
CRVS0209
CRVS0210
CRVS0211
CRVS0212
CRVS0213
CRVS0214
CRVS0215
CRVS0216

.44 .45 .53 .82 1.08 1.31
.46 .47 .51 .67 .86 1.04
.47 .47 .48 .59 .77 .94
.48 .48 .50 .60 .80 1.03
.50 .49 .51 .63 .90 1.37
.50 .50 .53 .65 1.07 1.87
.50 .50 .55 .70 1.23 2.43
.50 .50 .57 .76 1.40 3.06
.52 .52 .60 .83 1.55 3.60
.52 .53 .65 .93 1.74 4.15
.52 .53 .68 1.03 1.93 4.90
.52 .56 .76 1.18 2.10 4.80
.52 .52 .61 1.05 1.32 1.57
.53 .54 .63 .94 1.10 1.32
.55 .56 .62 .86 1.02 1.20
.57 .57 .63 .82 .93 1.20
.58 .58 .64 .80 1.00 1.43
.58 .60 .65 .83 1.08 1.87
.60 .60 .68 .84 1.22 2.40
.62 .62 .70 .87 1.37 2.91
.62 .62 .75 .94 1.55 3.50
.64 .66 .80 1.03 1.75 4.10
.67 .67 .85 1.17 1.93 4.75
.67 .71 .96 1.38 2.23 4.90
.62 .64 .75 1.15 1.56 1.93
.65 .67 .75 1.10 1.35 1.59
.68 .69 .75 1.01 1.22 1.46
.70 .70 .78 .98 1.16 1.51
.72 .72 .79 .94 1.19 1.70
.72 .72 .81 .94 1.28 2.00
.74 .76 .83 .96 1.40 2.42
.77 .77 .87 1.00 1.56 3.00
.78 .78 .91 1.10 1.75 3.50
.80 .80 .97 1.22 1.94 4.30
.80 .82 1.00 1.32 2.14 4.90
.82 .83 1.05 1.47 2.40 5.10

FFG70001
 FFG70002
 FFG70003
 FFG70004
 FFG70005
 FFG70006
 FFG70007
 FFG70008
 FFG70009
 FFG70010
 FFG70011
 FFG70012
 FFG70013
 FFG70014
 FFG70015

1	0	20	4500	408	9.07	3.14	.593	.747	0	0	6	40000	0	0	2	1	2	1				
26	.0005	0	0	0	5	4	0	0	0	0	1000	0	0	.30								
45	2	2	0	0	14	15	156	0	0	0	45											
61	1	2	0	.08	0	10	20	.10	20	.05	0	2	1	0	2							
100	1	2	1	24	1	27	1	41	1	61	8	64	1	65	1	100	1	102	1	116	800	119
124	10000	124	1	131	40	168	2	180	1	165	1	212	2	213	6	200	1	204	1	208		
144	1	209	2	214	4	215	1	221	12	226	1	230	1	232	1	190	1	242	193	217		
164	10	219	1	48																		
400	0	111.5																				
1003	41.4																					
1825	22																					
2131	15000																					
2161	9000	0	13000																			
2250	1.32	1.17	.77	1.11	.94	.93	.99	1.42	1.18	1.33	1.12	2.23	1.72	3.30								
2264	.96	1.72	2.82	1.03	2.69	1.65	1.33	1.73	.62	1.10	8.5											

KARA0001
KARA0002
KARA0003
KARA0004
KARA0005
KARA0006
KARA0007
KARA0008
KARA0009
KARA0010
KARA0011
KARA0012
KARA0013
KARA0014
KARA0015
KARA0016
KARA0017
KARA0018

1 34 20 8750 538 0 0 .61 .83 0 0 6 0 0 4 2 2 1
26 .0005 0 0 0 5 4
45 1 2 0 0 0 55 55 430 0 0 0 90
61 1 2 0 .10 0 10 20 .10 20 0 0 2 1 0 1
64 .08
701 45.0 25.0
717 12.0
2121 163500
31 4 3
2152 1000
1013 10
2250 1.0 .9 .9 1.0 .8 .8 1.0 .5 .6 .5 .7 1.0 .4 .2 .7 .7 .7 .8 .4 .6 .5
2271 .5 .5 .7 8.0
2274 8.5
100 1 3 1 9 1 25 1 48 1 49 1 57 31 64 1 66 1 71 1 82 4 100 4 102 2 115
126 3200 119 12000 124 2 136 2 134 2 139 2 144 4 143 2 154 2 156 1 158
146 2 32 1 159 80 168 40 173 80 172 8 174 2 180 1 184 12 200 .5 204
166 1 208 1 209 1 212 1 213 1 214 162 217 1 222 12 226 1 242 1 244 1 31

APPENDIX F

NOMENCLATURE LIST

APPENDIX F
NOMENCLATURE LIST

AEDPWG	Average endurance power per electric generator, horsepower
AHVOL	Available hull volume, cu. ft.
AM	Cross sectional area amidships, sq. ft.
AREA	Projected lateral area above water, sq. ft.
ATVOM	Available tankage volume, cu. ft.
AVAV	Available arrangement volume in hull, cu. ft.
AVEDPW	Average endurance power, horsepower
AVSP	Average sea speed in North Atlantic Ocean, knots
B	Beam at midship waterline, ft.
BEAMMB	Maximum beam of machinery box, ft.
BHRAT	Beam to draft ratio
BM	Metacentric radius, ft.
B/H	Beam to draft ratio
CALPH	Transverse moment of inertia coefficient
C _B	Block coefficient
CG1	Vertical center of gravity of weight group 1, ft.
CG2	Vertical center of gravity of weight group 2, ft.
CG3	Vertical center of gravity of weight group 3, ft.
CG4	Vertical center of gravity of weight group 4, ft.
CG5	Vertical center of gravity of weight group 5, ft.
CG6	Vertical center of gravity of weight group 6, ft.
CG7	Vertical center of gravity of weight group 7, ft.
CGFLD	Vertical center of gravity of ship at full load, ft.
CGLDS	Vertical center of gravity of ship loads, ft.
CGLSP	Vertical center of gravity of light ship, ft.

COGAS Combined gas turbine and steam plant
 C_p Prismatic coefficient
 CPM Machinery box prismatic coefficient
 C_r Residual resistance coefficient
 CR1() } C_r arrays for
 CR2() } Taylor's Standard Series
 CR3() } Resistance estimate
 C_v Volumetric coefficient
 CVK Correction to minimum machinery box depth to account for
 structures, ft.
 C_{wp} Waterplane coefficient
 C_x Midship section coefficient
 C_α Same as CALPH
 DO Depth at forward perpendicular, ft.
 D10 Depth at amidships, ft.
 D20 Depth at after perpendicular, ft.
 DAVG Average hull depth, ft.
 DCMARG Design, construction weight margin (e.g., 10% as 0.10)
 DECKHT Height of deck for payload items and raised deck, ft.
 DELCF Frictional resistance correction
 DEPMB Minimum machinery box depth
 DHAMIN Minimum deckhouse volume, cu. ft.
 DHSV Smallest deckhouse volume, cu. ft.
 DHV Deckhouse volume, cu. ft.
 DISPFL Full load displacement, tons
 DISPLS Light ship displacement, tons
 DISTOL Tolerance for displacement iteration

DPROP Diameter of propeller, ft.
 DPTRY Displacement estimate, tons
 DSEDPW Design endurance power, horsepower
 DUR Duration of voyage for stores, days
 DURPAS Duration of stores for passengers, days
 DURTRP Duration of stores for troops, days
 EAV() Array for storing 24 hour average electric loads, KW
 EBT() Array for storing battle electric loads, KW
 ECR() Array for storing cruise electric loads, KW
 EDPWPE Power required per engine at endurance speed, horsepower
 EHP Effective horsepower
 EHPAPP Effective horsepower with appendages
 EHPBH Effective horsepower bare hull
 ELMARG Electric load margin (e.g., 30% as 0.30)
 EMETYP Emergency electric plant type
 ENCVOL Total internal volume of ship, cu. ft.
 ENDUR Ship endurance range, nautical miles
 EXCKG Excess center of gravity height beyond that required by
 stability criteria, ft.
 FO Freeboard at forward perpendicular, ft.
 F7 Flare factor
 F10 Freeboard at amidships, ft.
 F20 Freeboard at after perpendicular, ft.
 FAVG Average freeboard, ft.
 FINST Fin stabilizers
 FLDISP Full Load displacement, tons

FNDEN() Array for storing the calculated density for each function,
 lbs./cu. ft.

FRAUXB Fuel rate for auxiliary boilers, lbs. / hr.

FRCGAS Fuel rate for COGAS propulsion plants, lbs./hr.

FRDIEG Fuel rate for diesel electric generators, lbs./hr.

FRSTM All purpose fuel rate for steam plants, lbs./hr.

FSCORR Stability free surface correction, ft.

GM Metacentric height, ft.

GMBMIN Minimum GM/B stability value

GM/B Ratio of metacentric height to beam

H Full load draft, ft.

HABCVK Minimum height of machinery box above CVK, ft.

HCOR Correction to minimum machinery box depth to account for
 hull shape, ft.

HTTYP Type of heating

HULMAT Type of hull material

HVAW Hull volume above waterline, cu. ft.

HVBW Hull volume below waterline, cu. ft.

ICONST Variable used to control printing status for miscellaneous
 coefficients

IT() Array used to store payload item numbers

JHPOPT Variable used to set type of speed-power calculations
 required

KB Height of the center of buoyancy, ft.

KELEC Variable used to set type of electric plant calculations
 required

KG Height of the center of gravity, ft.

KGEOM Variable used to set type of geometry calculations required
 KGTRY KG estimate, ft.
 KW24AV 24 hour average electric load, KW
 KWEMER Total emergency electric capacity installed, KW
 KWINST Total installed ship service and emergency electric capacity, KW
 KWPEMG KW per emergency generator
 KWPRD KW per diesel generator installed
 KWPRGT KW per gas turbine generator installed
 KWPRSG KW per steam turbine generator installed
 KWSSSG KW per ship service generator
 KWSSER Total ship service electric capacity installed, KW
 L Length between perpendiculars, ft.
 LB Length to beam ratio
 LBP Length between perpendiculars, ft.
 LBRAT Length to beam ratio
 LEN Length between perpendiculars, ft.
 LENMB Machinery box length, ft.
 LMB Same as LENMB
 LRD Raised deck length, ft.
 L/B Length to beam ratio
 MXDIS Maximum number of weight iterations
 MXFCKW Maximum functional electric load, KW
 MXITM Maximum payload item considered
 MXVCG Maximum number of vertical center of gravity iterations
 NACC Total number of accommodations
 NACSC Number of accommodations for ships company

NB Number of boilers installed
 NCOMP() Array for storing functional component names
 NCPO Number of CPO's in ships company
 NCREW Number of enlisted crew in ships company
 NE Number of engines installed
 NEEND Number of gas turbine engines required at endurance speed
 NELC() Array for storing electric group names
 NEMG Number of emergency electrical generators
 NFLAG Number of flag personnel on ship
 NGAVG Number of electric generators for 24 hour electric load
 NGFCLD Number of ship service generators for maximum functional
 load
 NGTG Number of gas turbine generators installed
 NHSD Number of high speed diesel generators installed
 NLS Number of low speed diesel generators installed
 NMSD Number of medium speed diesel generators installed
 NOFF Number of officers in ships company
 NPASS Number of passengers on ship
 NR Number of nuclear reactors installed
 NS() Array for storing specification names
 NSHFT Number of shafts installed
 NSHIP Number of ship being calculated
 NSR() Array for storing summary of results names
 NSSG Number of ship service generators
 NSTG Number of steam turbine generators installed
 NTRP Number of troops on ship
 NTYP() Array for storing the type names

NWT() Array for storing the weight group names
 P() Array for storing payload data
 PASTYP Type of passageway
 PCEND Propulsive coefficient at endurance speed
 PCMXSP Propulsive coefficient at maximum sustained speed
 PPTYP Propulsion plant type
 PRPTYP Propeller type
 PRTOUT Variable used to control the amount of results printed
 Q() Array for storing the quantity of each payload item used
 RATFP Ratio of endurance power per engine to full power per engine
 RDAV Raised deck arrangements volume, cu. ft.
 RHAV Required hull arrangements volume, cu. ft.
 RPM Propeller revolutions per minute
 RSSV Required superstructure volume, cu. ft.
 RTAV Required tankage arrangements volume, cu. ft.
 S() Array for storing ship specifications
 SFCAED Average endurance specific fuel consumption, $\frac{\text{lbm}}{\text{SHP}\cdot\text{HR}}$
 SFCFP Full power specific fuel consumption, $\frac{\text{lbm}}{\text{SHP}\cdot\text{HR}}$
 SHFTYP Shaft type
 SHP Shaft horsepower required at maximum sustained speed
 SHPE Shaft horsepower required at endurance speed
 SLRAT Speed to length ratio, knots/ft^{1/2}
 SSETYP Ship service electric plant type
 SSMAT Superstructure material type
 T Tankage coefficient
 TAAV Total available arrangements volume, cu. ft.

TANKVL Tankage volume, cu. ft.
THV Total hull volume, cu. ft.
TRAV Total required arrangements volume, cu. ft.
V() Array for storing volume of functional groups, cu. ft.
VCG Vertical center of gravity, ft.
VCG() Array for storing vertical centers of gravity
VCGTOL Tolerance for VCG iteration
VEND Ship endurance speed, knots
VM() Array for storing moment of weight groups, ft.--tons
VOLHUL Internal volume of hull, cu. ft.
VOLMB Internal volume of machinery box, cu. ft.
VOLSHP Total internal volume of ship, cu. ft.
VOLSST Internal volume of superstructure, cu. ft.
VOLTOT Total internal volume of ship, cu. ft.
VOMPSS Superstructure volume required for payload items, cu. ft.
VRLOAD Total weight of load items, tons
VSUS Maximum continuous sustained speed, knots
VTKREQ Tankage volume required, cu. ft.
VWT() Array for storing weight of functional groups, tons
 V/\sqrt{L} Ship speed to length ratio, knots/ft^{1/2}
W() Array for storing weight group results, tons
WARM Weight of armor, tons
WBHS Weight of basic hull structures, tons
WBRGS Weight of bearings, tons
WDHS Weight of deckhouse structure, tons
WFAUXB Weight of fuel oil for auxiliary boilers, tons
WFELEC Weight of fuel oil for electric generators, tons

WFFL	Weight of free flooding liquids, tons
WFG4	Weight of functional group 4 (hull structures), tons
WFG5	Weight of functional group 5 (ship systems), tons
WFPROP	Weight of fuel for propulsion use only, tons
WGP4	Weight group 4 minus groups 450 and 451, tons
WGP7	Weight group 7 minus groups 750 and 751, tons
WPAYIN	Total weight of payload items input, tons
WPROP	Weight of propellers, tons
WSHAFT	Weight of shafting, tons
WSS	Weight of secondary structures, tons
WTGP1	Weight of BSCI weight group 1, tons
WTGP2	Weight of BSCI weight group 2, tons
WTGP3	Weight of BSCI weight group 3, tons
WTGP4	Weight of BSCI weight group 4, tons
WTGP5	Weight of BSCI weight group 5, tons
WTGP6	Weight of BSCI weight group 6, tons
WTGP7	Weight of BSCI weight group 7, tons
WTMARG	Weight of margin for design/construction, tons
WTSHIP	Full load displacement of ship, tons