

Norwegian Wood:
A Case Study of Stave Churches

by
Nicholas Todd Harris
B.A., Haverford College, 1977

Submitted in Partial Fulfillment
of the Requirements for the
Degree of
Master of Architecture
at the
Massachusetts Institute of Technology
February 1982

© Nicholas Todd Harris, 1982

The author hereby grants to M.I.T. permission to reproduce
and to distribute publicly copies of this thesis document
in whole or in part.

Signature of Author Department of Architecture
January 1982

Certified by Lawrence Anderson, Dean Emeritus
Department of Architecture

Accepted by Edward Robbins, Chairman
Departmental Committee for Graduate Students
Department of Architecture

MASSACHUSETTS INSTITUTE
OF TECHNOLOGY
JAN 27 1982

NORWEGIAN WOOD:
A Case Study of Stave Churches

by

Nicholas Todd Harris

Submitted to the Department of Architecture
on January 14, 1982
in partial fulfillment of the requirements
for the degree of Master of Architecture

Abstract

This thesis addresses the question: How did the medieval Norwegians meet the challenges entailed in designing a small wooden building (e.g., resisting snow and wind loads, detailing wood connections), and create an architectural masterpiece?

Thesis Supervisor: Lawrence Anderson
Title: Dean Emeritus of the
Department of Architecture

ACKNOWLEDGEMENTS

I am grateful to the Thomas J. Watson Foundation for a fellowship that enabled me to travel to Scandinavia and study first hand all of the remaining stave churches.

I am also grateful to the National Endowment for the Arts for a grant that assisted me in my research.

I warmly thank Lars Roede, former Director of the Norwegian Society for the Preservation of Historical Monuments, for generously providing me with a great deal of valuable documentation from the National Archives of Norway, including a set of measured drawings of a number of the stave churches.

I extend my appreciation to Hakon Christie for including me on the excavation and restoration of the Uvdal Stave Church.

I am grateful to Roar Hauglid, the Norwegian author of many renowned articles and books on stave churches, for his personal tour of stave architecture.

I am deeply indebted to Waclaw Zalewski, Professor of Architecture at MIT, whose insightful comments shed a great deal of light on the structural principles of stave construction.

Finally, I am especially grateful to Lawrence Anderson, Dean Emeritus of the MIT Department of Architecture, for his carefully considered criticisms which helped mold this work, and for his shared devotion to things made of wood.

Table of Contents

	<u>Page</u>
Abstract	3
Acknowledgements	5
Part I Introduction	11
Norwegian Stave Churches (Map)	12
On the Origin of Stave Churches	17
The Stone <u>vs.</u> Wood Debate	24
The Evolution of the Stave Church	31
The Holtdalen Stave Church	32
The Urnes Stave Church	34
The Gol Stave Church	36
The Stave Technique of Building	40
Part II Preparing the Wood for the Construction of the Torpo Stave Church	44
The Stone Foundation and the Primary Sill	46
Joints of the Primary Sill	48
The Secondary Sill and the Corner Posts	50
The Floor Planks	52
The Floor	54
The Column Wall	56
Bracing the Column	58
Wooden Braces	60
The Raising of the Column Wall	68
The Three-dimensional Chassis	69

Table of Contents

	<u>Page</u>
Part II	
(cont'd)	
The Stave Truss	71
The Stave Wall and the Aisle Roof . . .	72
The Stave Wall and the Drainage Hole	75
The Exterior	76
Part III	
Photographs	87
Door from the Garmo Stave Church . . .	89
Doorway from the Torpo Stave Church . .	91
North Entrance to the Urnes Stave Church	93
Detail of the North Door of the Urnes Stave Church	95
Detail of Animal Ornamentation of a Viking Ship	97
Carved Capital from the Urnes Stave Church	99
Carved Capital from the Urnes Stave Church	101
Painting on Wood at the Torpo Stave Church	103
The Martyrdom of St. Margaret from the Torpo Stave Church	105
Carved Head from the Hegge Stave Church	107
Head of Christ from the Urnes Stave Church	109
Columns and Braces of the Torpo Stave Church	111
Arcaded Bench and Column Base from the Torpo Stave Church	113

Table of Contents

	<u>Page</u>
Part III	
(cont'd)	
Stone Foundation, Sills, Corner Post, and Staves of the Torpo Stave Church . .	115
Nave and Chancel of the Holtdalen Stave Church	117
Medieval Norwegian Granary Built in the Stave Style	119
Apse of the Heddal Stave Church	121
South Side of the Heddal Stave Church	123
The Gol Stave Church	125
North Side of the Borgund Stave Church	127
Part IV	
Concluding Notes	129
Footnotes	132
Bibliography	133

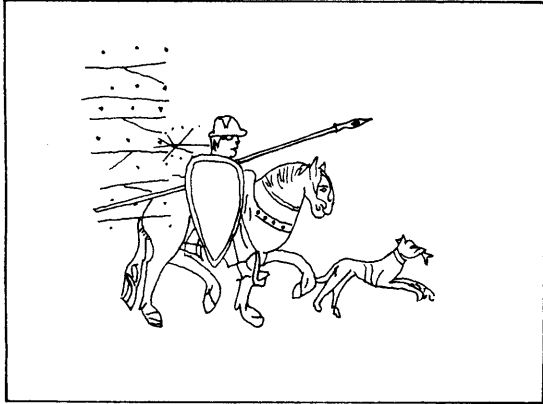

The runic letters in the left part of the picture suggest that the drawing, which is carved into a wall in the Gol Stave Church, was made in the Middle Ages.

After sacking and plundering their neighbors from across the seas, the Vikings returned home to Norway. They brought back not only the spoils of their victories, but also what was for them a new religion. Many Vikings con-

tinued to believe in their Nordic gods like Frey and Thor, but some converted to the new faith, Christianity. Perhaps because they were uncertain, or perhaps because they wanted to play it safe, some Vikings worshipped both the new and the old gods. The Vikings, who came from a long tradition of woodworking and shipbuilding, began building churches. The monuments they raised, as well as those built by their descendants, number among the finest examples of wooden architecture in Europe.

Knowing that a handful of these wooden churches had survived the ravages of time, I set out to see them first hand. I discovered that most of them are tucked away in the remote fiords and valleys in the lower half of Norway. A few are so isolated that they can be reached only by boat. Their isolation is no doubt one of the significant factors that has helped keep these structures in good condition for nearly one thousand years. In the course of my travels through Norway I was fortunate enough to see all of her stave churches, and I was impressed that though all thirty-one bore a family resemblance, each one maintained a distinctive character of its own. For example,

Norwegian Stave Churches

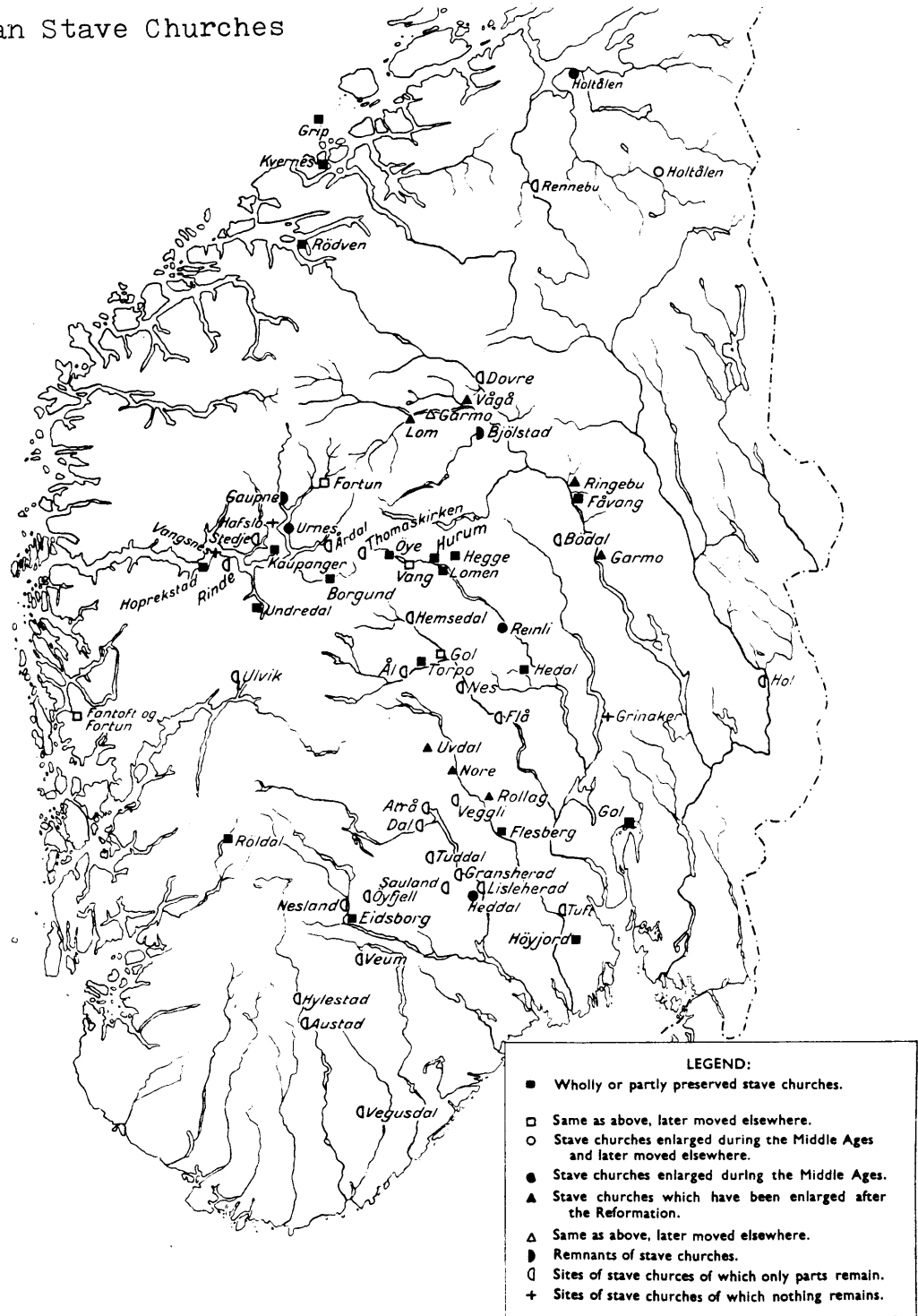

Probably the finest stave churches were those sponsored by prosperous trading towns like Bergen, but unfortunately none of the stave churches built in an urban setting has survived. As a rule the survival of a stave church has been dependent on its being built in a remote valley, fiord or island, and away from the devastating fires that periodical-ly swept through the Norwegian wooden towns and villages.

the stave church at Kaupanger exhibited the highest degree of craftsmanship; the Torpo Church had the most impressive interior; Borgund had the best preserved exterior; and Urnes had the finest carvings and ornamentation.

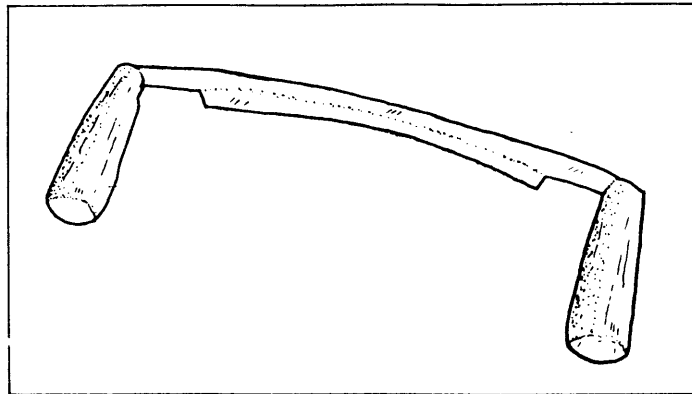

The drawknife was used to shape the rough tree trunks into round or elliptical columns. This tool was also used to shape the curved staves in the exterior walls.

At Urnes, I met an archeologist who is considered to be one of the foremost experts on stave churches. He was engaged in an archeological investigation of the church, a project he had been working on for over ten years. In my conversation with him in this remote church, I asked him numerous questions concerning the origin and development of stave architecture, and about the people who built and worshipped in these buildings. To most of my questions, he answered with the same reply, "I dare not say." It was not until some time later, after I had invested a good deal of time trying to answer my own questions, that I realized that modern man may never lift the veil of mystery that surrounds this handful of medieval timber buildings. I mention this story so that my reader is aware that what is not known about stave churches far exceeds what is known, and what we do know usually has some degree of uncertainty. Most of what is written both here and in the published literature is based in least in part on conjecture, and therefore should be taken with a healthy degree of skepticism. For example, it is common to hear exact dates assigned to the erection of particular churches. However, upon closer examination,

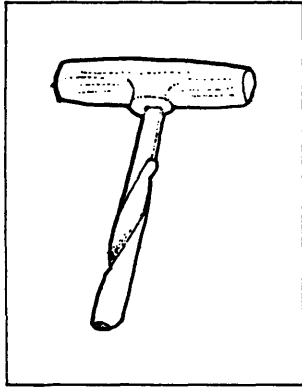

When dowelled joints were called for (as in the case of the clamping beams), this tool, called an auger, was used for drilling the holes.

one finds that these dates are based on the style of the church or its ornamentations, and that, judging from the large variance in opinion among the recognized experts, these dates can be off by as much as one hundred years. Likewise, this work, which emphasizes the construction and structural performance of the stave church, also has its degree of uncertainty. For example, because it is typical for wooden members to penetrate inside adjoining members, and because many of these joints have never been dismantled, the exact detailing of many connections is not known.

Nevertheless, I have illustrated many of these kinds of joints with the acknowledgement that these illustrations are no more than my opinion of how the connections were made. Since the drawings are based on my observation of the joints from the exterior, and my judgment of the interior, I do not pretend that the illustrations are accurate in all respects. With the current historical and architectural knowledge of the stave church somewhat limited, the reader is advised to adopt a healthy skepticism concerning all claims of fact about these wooden monuments; and with these words of caution, I present the results of my own investigation.

The question my thesis asks is: How did the medieval Norwegians meet the challenges entailed in designing a small wooden building (e.g., resisting wind and snow loads, detailing wood connections, etc.) and create an architectural masterpiece? To answer this question, I have illustrated, step by step, the construction of a stave church. The drawings, photographs and text show the following

stages of construction: (a) preparing the timber, (b) laying the rock foundation and building the sills, (c) laying the floor boards, (d) assembling and raising the post and braces of the column walls, (e) building the trussed-rafters of the roof, (f) assembling the stave walls, (g) the treatment of the exterior, (h) enriching the church with carvings, ornamentation and paintings. The building of the stave church includes an analysis of the structural system, and an explanation of how natural forces, such as wind, rain, and snow have each affected the final form of the church. Also included in this analysis is an examination of the tools and techniques employed by the carpenters in their art of building in wood. Particular attention is given to the different kinds of wood connections, which were especially designed to meet structural, sculptural or weatherproofing needs.

A problem arose in selecting the most appropriate church to illustrate the various stages of construction. Given that my aim was to emphasize design, carpentry, and structural engineering, the stave church from Torpo came to mind as the logical candidate, because in these categories it rates very highly. However, in other categories it was a major drawback -- its chancel and apse were demolished in the last century, and its exterior has been significantly altered since the Middle Ages. In order to keep the virtues of Torpo, and at the same time compensate for her shortcomings, I decided to use a second church, Borgund, to show the chancel, apse, and the treatment of

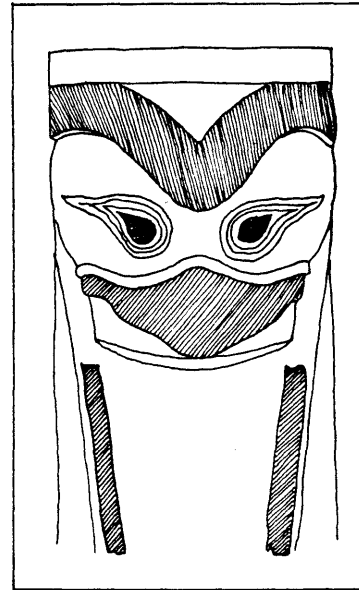

This face is also from the Hurum Church. The black color painted on the face was made from a tar pitch.

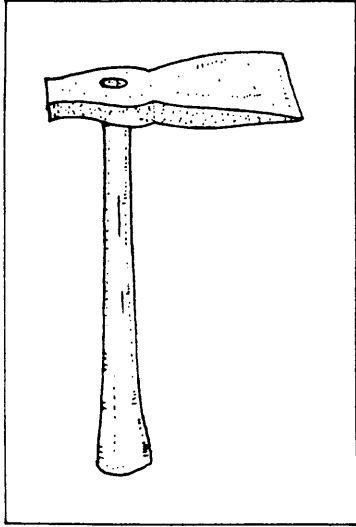

The axe, which was the Norwegian carpenter's most useful tool, came in a wide variety of shapes, sizes and forms. This particular version was designed for cutting grooves.

the exterior. In short, the "building" of a stave church begins with Torpo (where the interior is highlighted) and shifts to Borgund (where the exterior is emphasized). Together these two churches will be used to cover the basic principles of stave construction. The final portion of the thesis covers the topics of ornament and decoration. Through photographs and text, the last section shows how the Norwegian designers enriched their buildings with carvings, paintings and architectural detailing.

In order to place this exploration of stave architecture within its proper context, the introduction includes a short history, which gives the reader a thumbnail sketch of the rise and fall of this building tradition. A somewhat longer commentary is offered concerning the debate that has arisen in the literature about the alleged impact and influence of the stave church on Gothic and Romanesque architecture.

Also included in the introduction is a set of plans and sections of three other stave churches, Holtdalen, Urnes and Gol. These churches were selected because each of them represents a crucial stage in the development of stave architecture. Holtdalen is an example of the oldest and simplest form of the stave church. Urnes represents an intermediate and experimental stage of the development. Gol is an example of a late stage in which the complex design is fully articulated. The order in which the three churches are presented is organized from

early to late, and from simple to complex; it is not, in my opinion, a ranking based on quality or merit.

On the Origins of Stave Churches

Many of the conjectures concerning the origin of stave churches are in their own way as imaginative and provoking as the churches themselves.. No one is certain about the true origin of the churches, but because the question of where they came from is such a tantalizing one, the lack of hard evidence has not inhibited the attempt to connect the art of stave church building with a dark and remote past. Theories have ranged as far afield as the Orient, and as far back in time as the Vikings. The oriental appearance of many of the churches has led some to believe that the stave churches are connected in some mysterious fashion to the tradition of Japanese and Chinese pagodas: others have seen the churches as essentially upside-down Viking ships.

Calling such theories fanciful and unfounded, most modern scholars generally frown on these notions. As a reaction against fanciful theorizing, there is an attitude that prevails in scholarly circles that might be characterized most accurately as a mistrust of elaborate explanations about the origins of the stave church. Some scholars go so far as to hold the view that, because their medieval birth is hidden under an impenetrable veil of secrecy, we should admit that we will never understand the origin of stave churches with any degree of certainty.

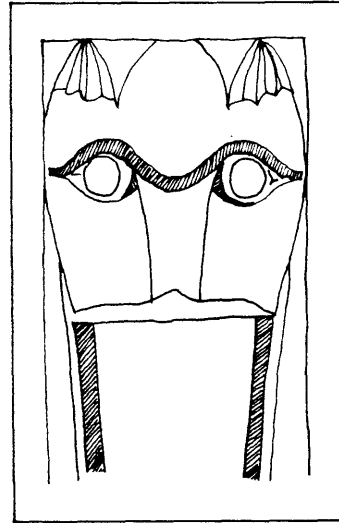

Probably carved in the beginning of the thirteenth century, this head is atop a column at the Hurum Stave Church.

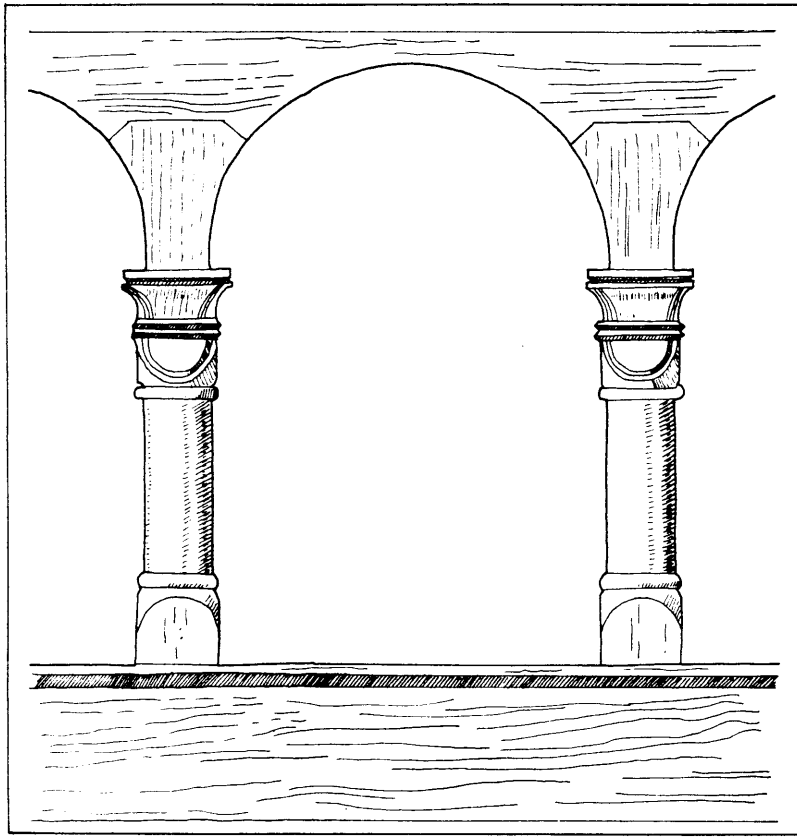

This drawing is of the arcade that surrounds the Gol Stave Church near Oslo. The scale is one-eighth actual size. The cube capitals and bases of the wooden columns bear a strong resemblance to Norman stone architecture built in England and France during the Middle Ages.

Despite the large amount of uncertainty concerning these old buildings, there is general agreement on a number of points. For instance, the Black Plague, which in 1349 killed between one-half and two-thirds of the Norwegian population, is also blamed for the termination of new stave buildings. At the end of the plague, there was slightly more than one-third of the population left alive. This meant that the churches had very few resources to draw upon, and with the economy virtually collapsed, it was only with great difficulty that it was possible to maintain the existing churches, much less consider the

underwriting of construction of new stave churches. Even if the church had had a sufficient financial base to build new stave constructions, there were far more existing churches than the surviving population could use.

Two or three hundred years later the Norwegian population regained the ranks it had lost in the Black Plague, but by this time it was too late for stave architecture. The sophisticated art of stave church building, a tradition handed down from father to son, was lost to antiquity. By the time the need was established for new churches, the styles and techniques had drastically changed.

Finding a date for the beginning of stave churches is a much harder task, and it should be recognized that assigning a specific date will be somewhat arbitrary. The year 1000 is generally accepted as the time when Christianity was introduced into Norway. It probably took another twenty-five to fifty years before the new Christian beliefs were accepted with enough conviction to warrant the construction of a church.

Though the stave tradition ended only a few centuries after it had begun, it was an active and vibrant age of building. In three-hundred years nearly one-thousand stave churches were built, which means that on the average approximately three stave churches were being built every year. The fact that so many constructions were underway meant that the Norwegian designers and builders had the privilege and opportunity to test and draw from a wide range of architectural ideas. Stave art evolved when ideas that resulted in unstable structures or visually unpleasing designs were discarded in favor of those that were sound and satisfying.

Some scholars believe that the stave church is an outgrowth of a long tradition of pagan temples, and that there was a smooth transition, architecturally speaking, between the last of the pagan temples and the first of the Christian stave churches. There is a certain plausibility

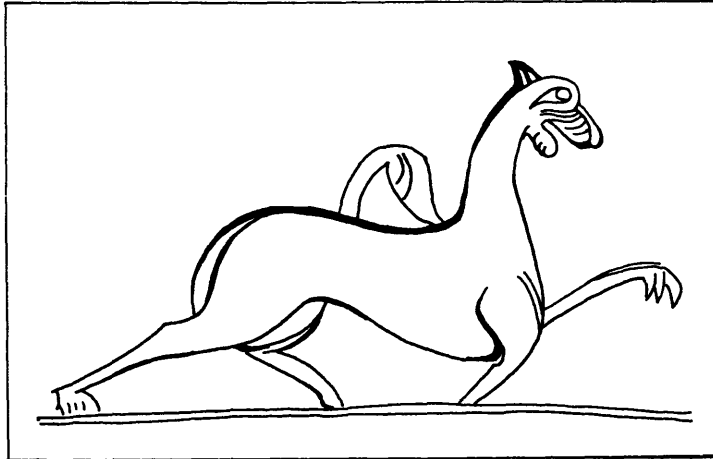

It is curious that the lion played such an important role in the imagination of the medieval Norwegian mind since few, if any, Scandinavians actually saw a lion. This lion is painted onto the inside wall of the west gable of the Al Stave Church.

in this conjecture, since the craftsmen who built the last of the pagan temples were the same workmen who were called upon to build the first churches, and quite naturally would have employed the same tools and similar construction techniques. One can support such a view by showing that there are undeniably pagan constructions in these Catholic churches. For example, at the tops of the free-standing columns in many of the churches are carved heads of Nordic Gods, and it seems reasonable to believe that these heads were a carry-over from earlier pagan constructions.

In the year 921 an Arab trader called Ahmad Ibn Fadhlán recorded a detailed account of the pagan religious practices of the Vikings, who happened to be travelling south on the Volga when he encountered them. In his account Fadhlán writes: "When the merchants came to this anchorage they all left the boats, carrying ashore with them bread, meat, onions, milk and nabid (an alcoholic drink). They go to a high wooden pillar with a human face, round which were smaller figures, and behind

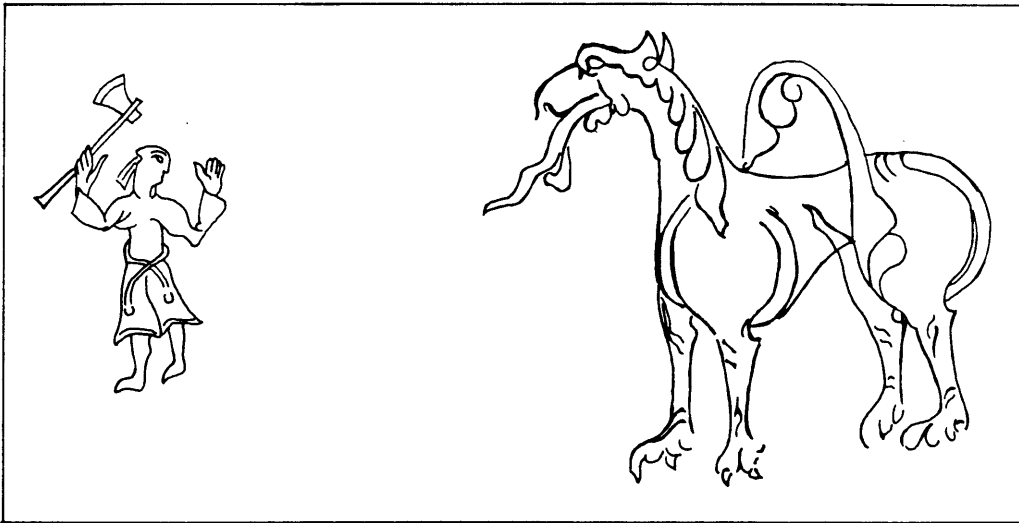

This scene of combat between a man swinging an axe and a fire breathing lion (?) is drawn on a wall at the stave church at Hedalen.

them tall posts in the ground. Each merchant approaches the tall figure, prostrates himself before it and says, "Oh Lord I have come a long way and I have with me this many slave-girls and that many sable furs (he mentions whatever merchandise he has with him). Now I come to you with this offering -- and he places what he has with him before the high wooden figure -- Please send me a merchant who has lots of dinars and dirhems (Arabic coinage) who will buy from me on my terms and without too much bartering"!¹ Ibn Fadhlān goes on to describe how the Vikings reward their Lord by hanging animal heads on the posts. Based on this account it seems reasonable to assume that the carved heads on the tall wooden columns of the stave church originated in Viking rituals. Ibn Fadhlān also describes the construction of Viking dwellings, which, roughly speaking, appear to have been about the same size as a medium-sized stave church. "When they have come from their land and anchored on, or tied up at the shore of, the Volga, which is a great river, they build big houses of wood on the shore, each holding ten to twenty persons more or less."²

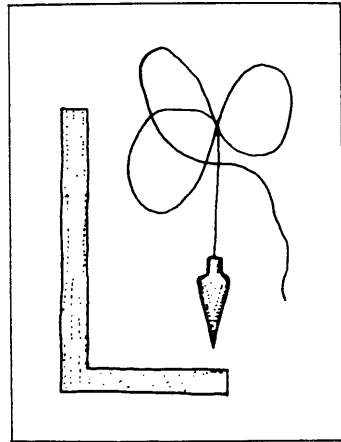

The framing square and the plumb bob were employed by the Norwegian master builders to achieve plumb, square, and level buildings.

Exactly what Viking architecture looked like is not well known. There have been attempts in Denmark to build a Viking long house, but the project has been strongly criticized because the placement of the main structural supports is not in agreement with archeological evidence of Viking dwellings. During the excavation of one of the Viking ships, a funeral "house" was unearthed. This primitively built structure at least shows that the Vikings utilized the stave technique, but to what extent they developed it is not known. Still, it does seem fair to claim that the continuity between the Viking funer-

al "house" and the stave church extends beyond the method of connecting timbers, because in both cases the structures had strong religious significance. The stave technique may have had sacred connotations in early Nordic cultures. However, the attempt to connect stave churches with the pagan past must reconcile the uncomfortable fact that there is no conclusive archeological evidence of any pagan temples in Scandinavia. It is hard to falsify the claim that indoor worship originated with the introduction of Christianity, and that previously worship was held out-of-doors.

If there were pagan temples there may be several reasons why none have survived. Possibly the church led an active campaign to burn them down. Another reason might be that the temples, like the early stave churches, were built on posts sunk directly into the ground, and that the structural supports collapsed eventually from the effects of moisture in the soil.

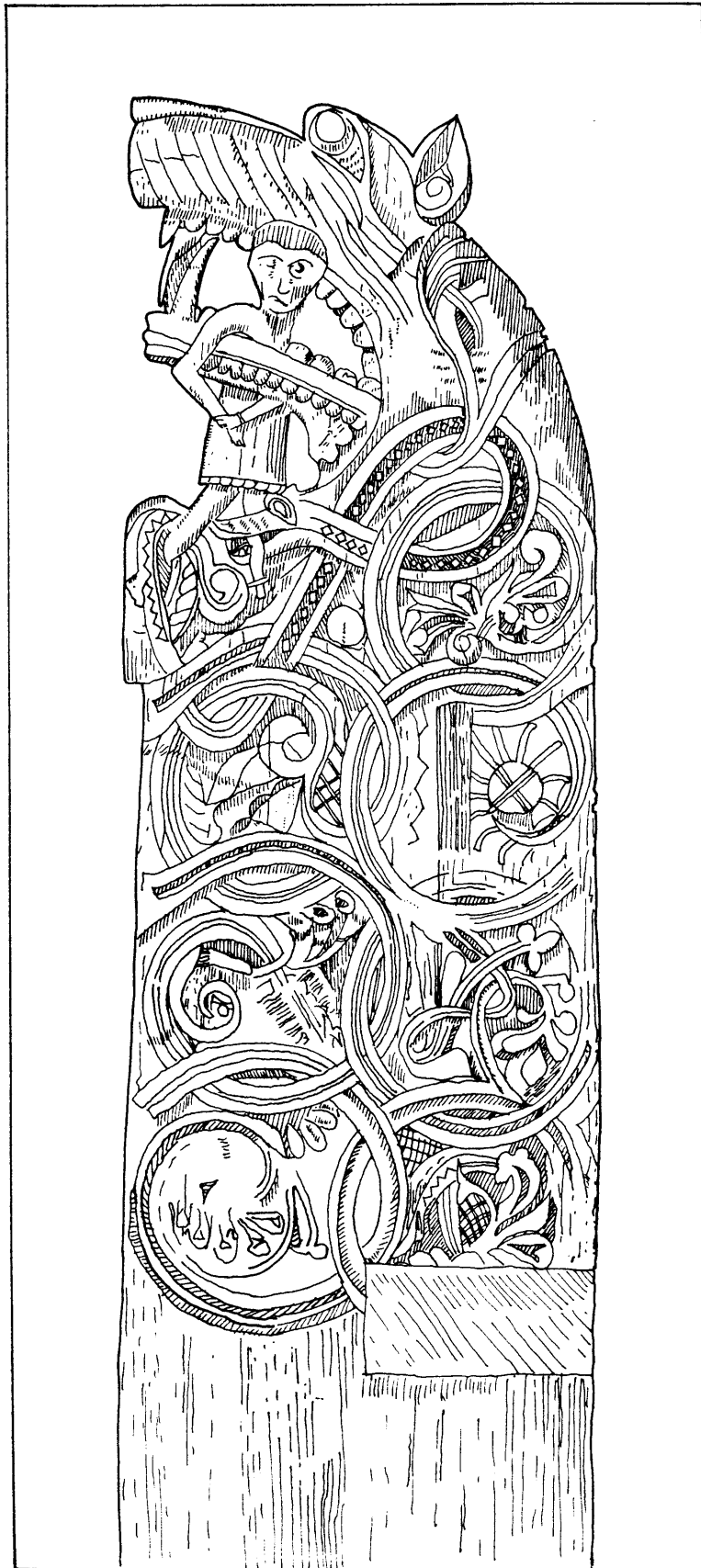

Possibly a representation of the sinner's fate, this carved pew from the Torpo Stave Church shows a man with his head caught in the jaws of a lion, while he is being bitten in the leg by a snake.

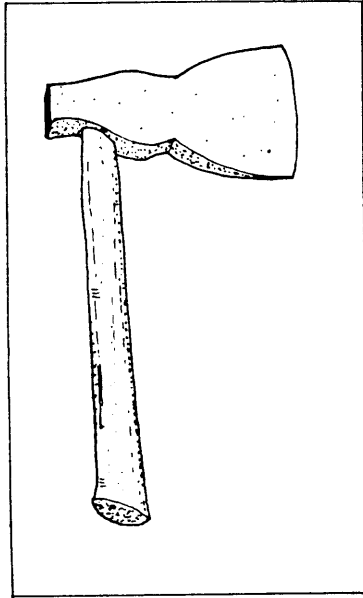

Because the medieaval carpenters did not know of the saw, the task of cutting boards was accomplished by the skilful use of the axe.

cube capitals on the columns, and an ambulatory with an arcade.

In the 1920's these similarities led the outspoken architectural historian, Joseph Strzygowski, to postulate that the stave church was an outgrowth of an indigenous building type, and that this timber building type spread from its origins in Northern Europe to Southern Europe. In southern climates it was translated into the local building material, stone. Exemplified by the stave church, the timber prototype building eventually became the model for the Gothic cathedral.

Strzygowski's theory that wooden architecture influenced stone architecture did not receive much attention until the 1960's, when it was challenged by the Norwegian

The Stone vs. Wood Debate

The acknowledged similarity between one kind of stave church (those with an elevated central nave) and many of the Romanesque and Gothic churches in various parts of Europe, has given rise to a heated debate among architectural historians about the influence of wood and stone building traditions on each other. The stave churches, with their rectangular field of columns that define a central nave and adjacent aisles, bear a strong similarity to Norman and Frankish Romanesque stone churches built in England, France, and even Scandinavia. There are other similarities as well: semi-circular arches between the free-standing columns,

The Stone vs. Wood Debate

historian, Roar Hauglid. Hauglid argued that Strzygowski's theory was built on an incorrect dating of the timber churches. Hauglid showed that the dates Strzygowski had assigned to the stave churches were much too early, and thus that they were much younger than Strzygowski had imagined. By comparing the new dates with those of the Romanesque stone churches, whose dates were accurately established, Hauglid presented a persuasive case that it was not the wood that had influenced the stone, but rather the reverse. The stave church, Hauglid believed, was a stone basilica modeled in wood.

Though other scholars objected to Hauglid's dating of the stave churches, the major objection that was raised was that the basilica and the stave church are not as similar as first thought. Their differences lie in that, unlike the basilica in which the aisles flank the nave on two sides, the aisles of the stave church surround the nave on all four sides. Likewise, on the outside, the aisle roofs enclose the entire perimeter of the building instead of simply the two long walls as they do in the basilicas. Hauglid admitted that this difference exists, but defended his theory saying that the difference in design was primarily the result of a structural problem that arose in changing building materials. The free-standing wooden posts needed more bracing than their stone counterparts in the basilicas. By continuing the aisle walls and roofs around the nave, the Norwegian builders were able to brace the free-standing columns more effectively. Hauglid

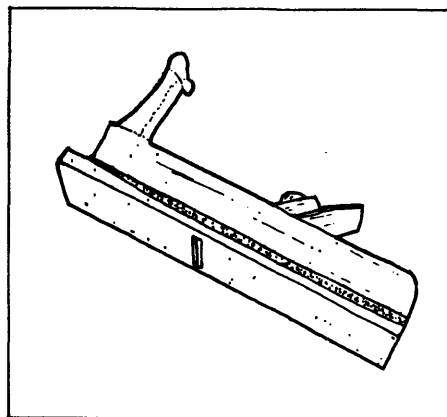

Planes used to build the stave churches closely resemble their modern counterparts.



This warrior and horse was carved into a column capital at the Urnes Stave Church in about the year 1160.

argued that the stone basilica did not need this extra bracing on the end. Hauglid's view gained wide acceptance over Strzygowski's because his datings were more accurate, and because his argument about the technical differences between stone basilicas and the stave church seemed plausible. Thus in Hauglid's view the stave church was dethroned, and rather than inspiring great stone cathedrals, the "basilica" stave church was an imitator of them.

The debate would have ended there, if it were not for an article published in 1976 by Walter Horn, a professor of architecture at the University of California. In "On The Origins Of The Mediaeval Bay System" Horn argued that the "ingenious but undisciplined" Strzygowski was correct when he wrote that the stone churches of Europe had their origins in northern wood construction. In his article Horn provided the documentation that Strzygowski's theory had lacked. Citing recent excavations in Holland and Germany (excavations that were undertaken after Strzygowski put forth his theory), Horn argued that timber architecture did indeed have a profound influence on stone

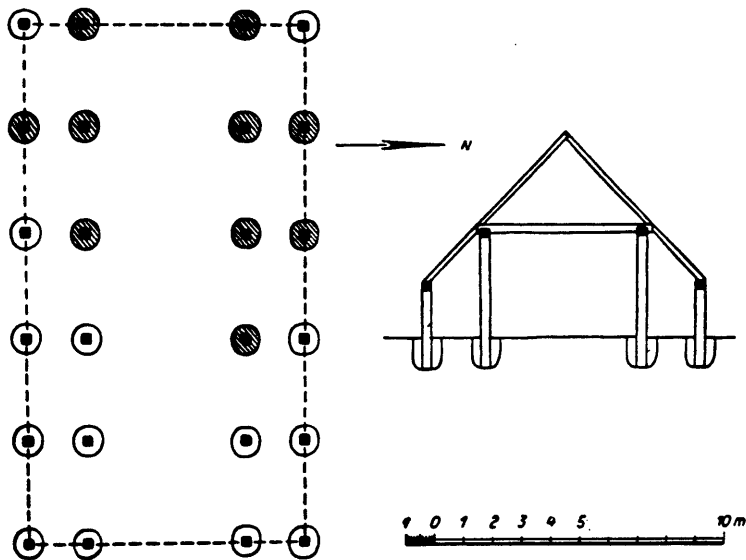

A Carolingian timber church unearthed at Breberen (near Aachen) Germany can be attributed to the eighth or ninth century by pottery shards and other accessories.

architecture. What was unearthed at the excavation in Breberen, Germany, was a Carolingian timber church. Judging from the post holes that remain, it is clear that the church had a central nave and side aisles. Pottery shards and other accessories discovered at the site led archeologists to believe that the church was from the eighth or ninth century. With this new evidence Hauglid's argument began to weaken, since the bay and aisle plan common to both the stave and Romanesque churches was observed in a timber church that predates both traditions.

At another site, this one in Ezinge, Holland, evidence was excavated that suggested that the bay and aisle system went back even further in history. At Ezinge a cattle barn from the third century B.C. was discovered. The excavation of the long barn revealed that it was constructed from a series of paired columns that divided a central "nave" from compartmental bays on the side. The system of wood

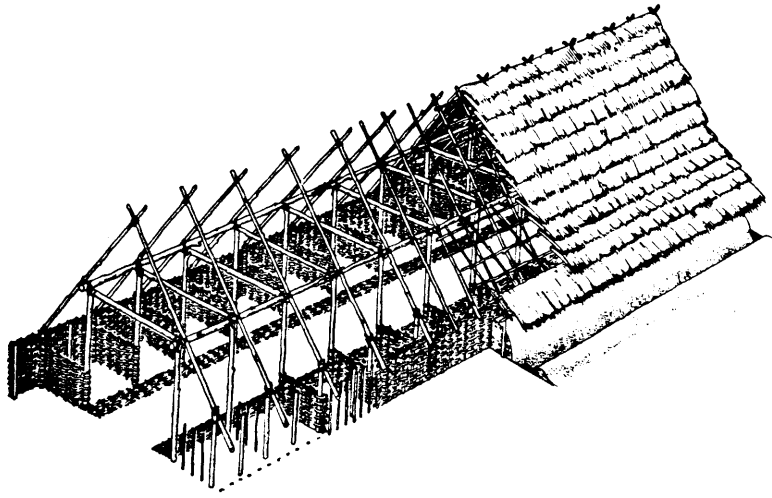

This cattle barn from Ezinge, Holland was built in the 3rd century B.C. and is a forerunner of the stave church.

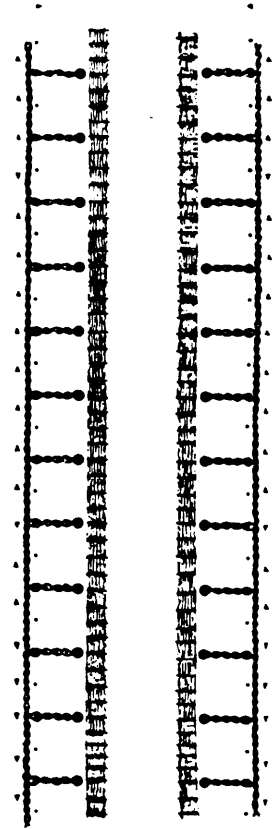

construction exhibited in both of these excavations resembles, in my opinion, that of the "basilica" type stave churches.

The bay and aisle design is a natural consequence of the limited spanning capabilities of timber in post and beam construction. Therefore, it is not surprising to find that the timber built bay and aisle has a continuous history dating as far back as the Iron Age. In the course of its evolution, the timber built bay and aisle has been utilized in houses, barns, and churches, and has been employed by both primitive and advanced societies. On the other hand, the stone version of the bay and aisle is a more recent phenomenon, and, because of its technically difficult vaulting requirements, has only been built by relatively sophisticated societies. There is no archeological evidence to support the claim that a primitive society ever built a bay-divided building in stone.

This drawing of a woman's face is from the Lom Stave Church. Carved on wood, historians estimate that it was made in about the year 1200.



The West Roman Type of Early Christian Basilica was an aggregate of three or more monolithic spaces and was not bay-divided. Walter Horn has made a persuasive case that this type of basilica spread north and came under the influence of bay and aisle timber construction which was already well established. The resultant bay and aisle stone basilica became the prototype for Romanesque and Gothic churches. The Romanesque and the Gothic emerged from the superimposition and interpenetration of two formerly separate and distinct building traditions, that of the West Roman Type of Early Christian Basilica with its monolithic internal spaces, and that of the bay-divided skeletal structures from the timber rich regions of Northern Europe.

Thus, the exchange between stone and wood building traditions was more complex than what was envisioned by either Strzygowski or Hauglid. The relationship between wood and stone is more accurately characterized as a dialogue with each contributing something to the other, than

A careful search of the walls of the Gol Stave Church is needed to find this piece of medieval graffiti. This piece is important because it is one of the few instances where the Norwegian artisans depict themselves in the act of creating a work. The straight lines of runic letters make them particularly well suited for being carved in wood by pointed instruments.

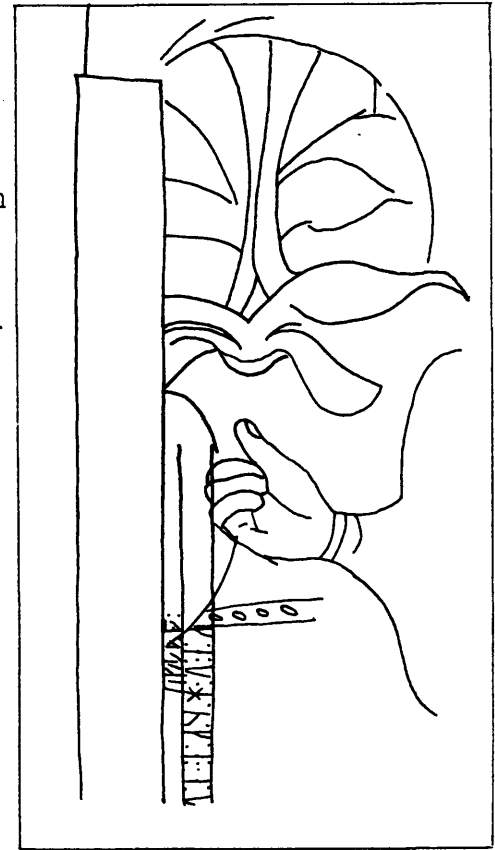

as one material simply copying the other. There is a sense in which the stave church was heavily influenced by the Romanesque style as witnessed by, among other things, the detailing of the cube capitals on the columns. There is another, perhaps more significant, sense in which the stave church and the Romanesque and Gothic cathedrals share a common ancestry in early timber construction of the north. The architects of all these churches, either directly or indirectly, were drawing on a tradition of bay division and skeletal construction that Northern Europeans had practiced for over a millenium, and that had been the guiding principle behind the construction of the houses in which they lived, the halls from which they governed their land, the barns which sheltered their livestock and harvests, the markets where they bartered their goods and produce, and perhaps even the churches and temples in which they worshipped.

The Evolution of the Stave Church

The stave church underwent considerable architectural development between the year 1000 (when Christianity was introduced into Norway) and 1349 (when the Black Plague devastated the Norwegian population). Between those two dates, it is possible to trace the stave church from its beginnings as a simple two room church (e.g., Holtdalen), through more ambitious designs (e.g., Urnes), to late and complex designs (e.g., Gol). In order to examine this course of evolution in greater detail, I have presented in the following pages plans and sections of each of the above mentioned churches. Holtdalen is presented first, followed by Urnes and Gol. This organization reflects a progression from simple to complex, and early to late.

The Holtdalen Stave Church

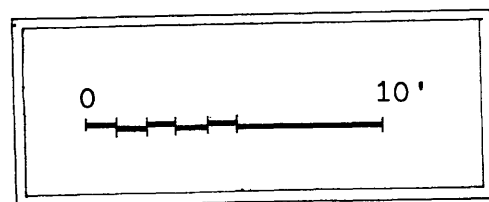
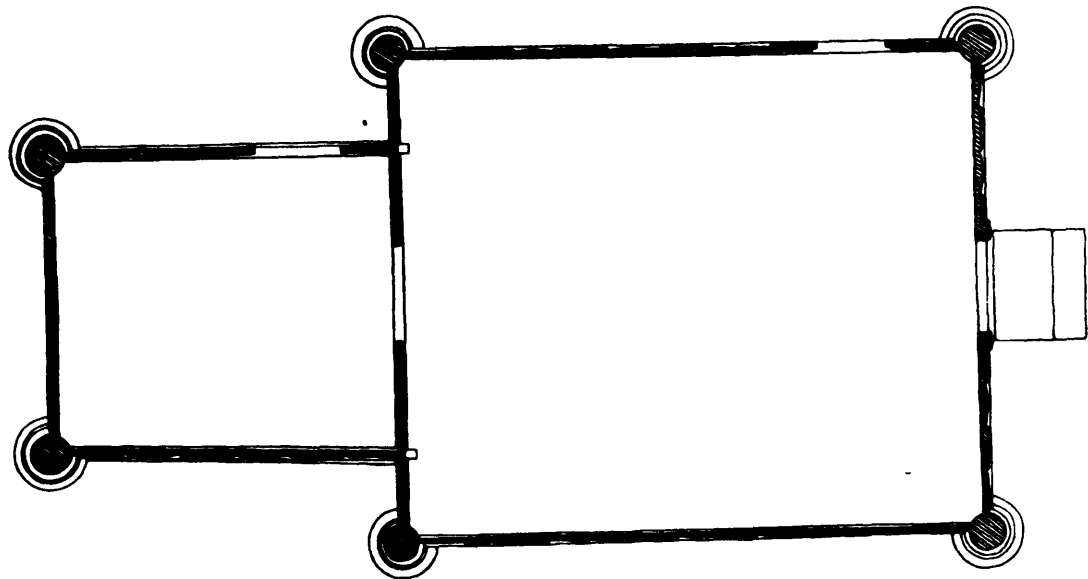

The stave church at Holtdalen is one of the oldest and simplest of all the stave churches. No one knows its exact age, but many experts believe it was built in about the year 1100. The larger room, the nave, measures fifteen feet by nineteen feet. The smaller room, the chancel, is nine feet by eleven feet. The main entrance is on the west wall (on the right hand side of the page). There are two other entrances, both on the south side of the building (on the top of the page). A distinguishing feature of this building is the round wooden globe at the base of each of the corner columns.

The Holtdalen Stave Church
(Longitudinal Section Looking
South)

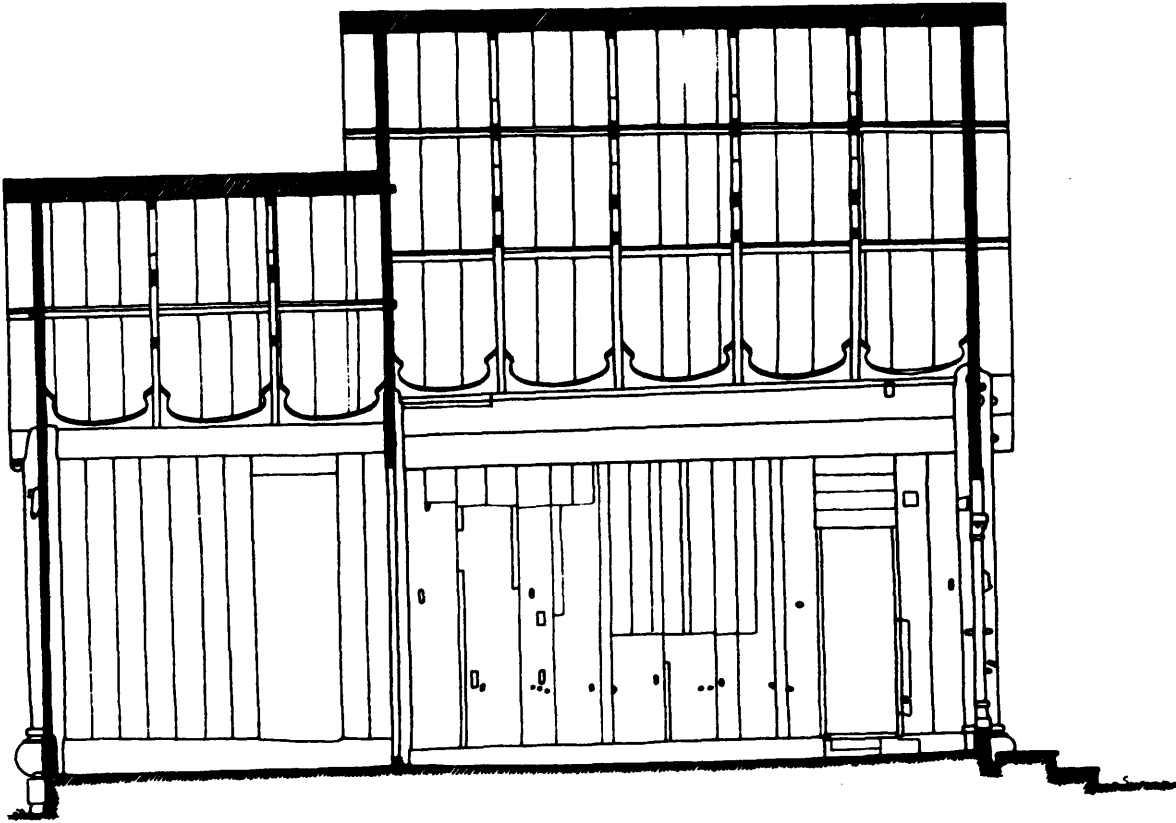

In the Middle Ages almost every Norwegian community built a stave church, and probably most towns erected a church similar to this one from Holtdalen. Because of its simplicity of design, the Holtdalen Stave Church is believed to represent the oldest type of stave church, and for this reason it is very helpful in tracing the evolution of stave architecture from its simplest to its most complex forms. If in fact Holtdalen is one of the oldest of the stave churches, we can assume that the curved wooden brackets used to stabilize the trussed-rafters are the oldest of the wooden braces employed by the stave architects. This view is reinforced by the fact that the Vikings used a similar brace hundreds of years before this church to strengthen their ocean-going vessels. We can also assume from the absence of both free-standing columns and an elevated central space, that these were later developments in the evolution of stave architecture.

The Urnes Stave Church
(Plan)

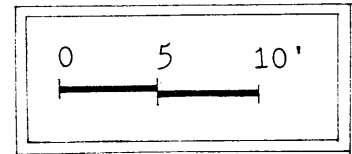
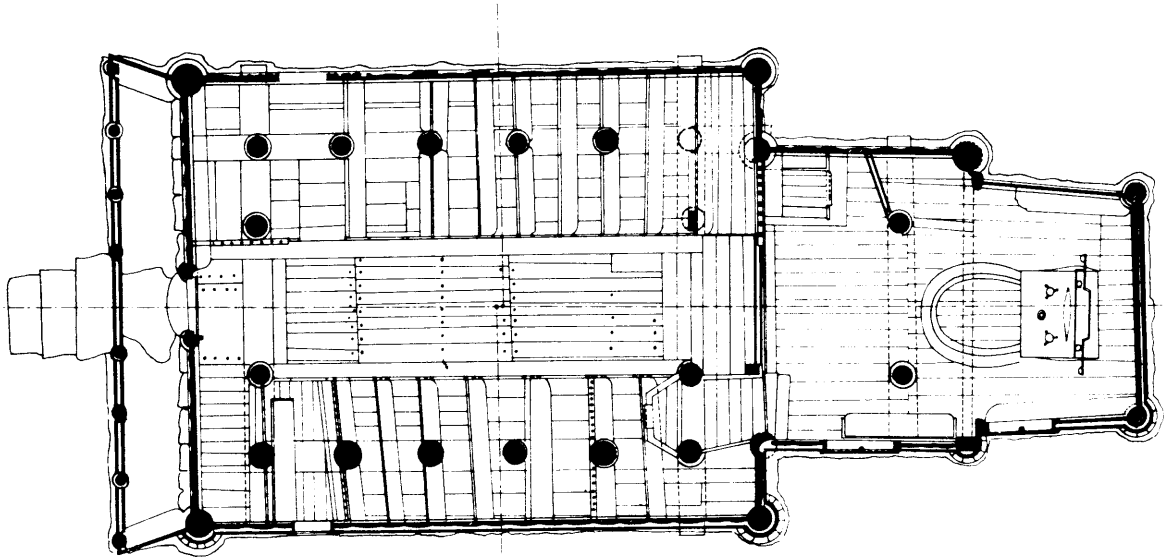

As a point of departure from the simple chancel and nave of the Holtdalen Church, the Urnes Church represents a later stage in the development of stave architecture. Probably the single most important change is the introduction of the rectangular field of columns in the nave, which both support the clerestory and an elevated ceiling, and which separate the nave from the aisles that enclose the nave on four sides. Corresponding to the free-standing columns is a new sill system designed for their support. The west entrance (on the left hand side of the page) has an arcaded porch or ambulatory, and according to some accounts men were supposed to leave their weapons in the ambulatory before entering the nave. Overall, the building is taller, longer and wider than the earlier Holtdalen type.

The Urnes Stave Church
(Longitudinal Section
Looking North)

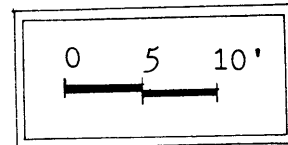
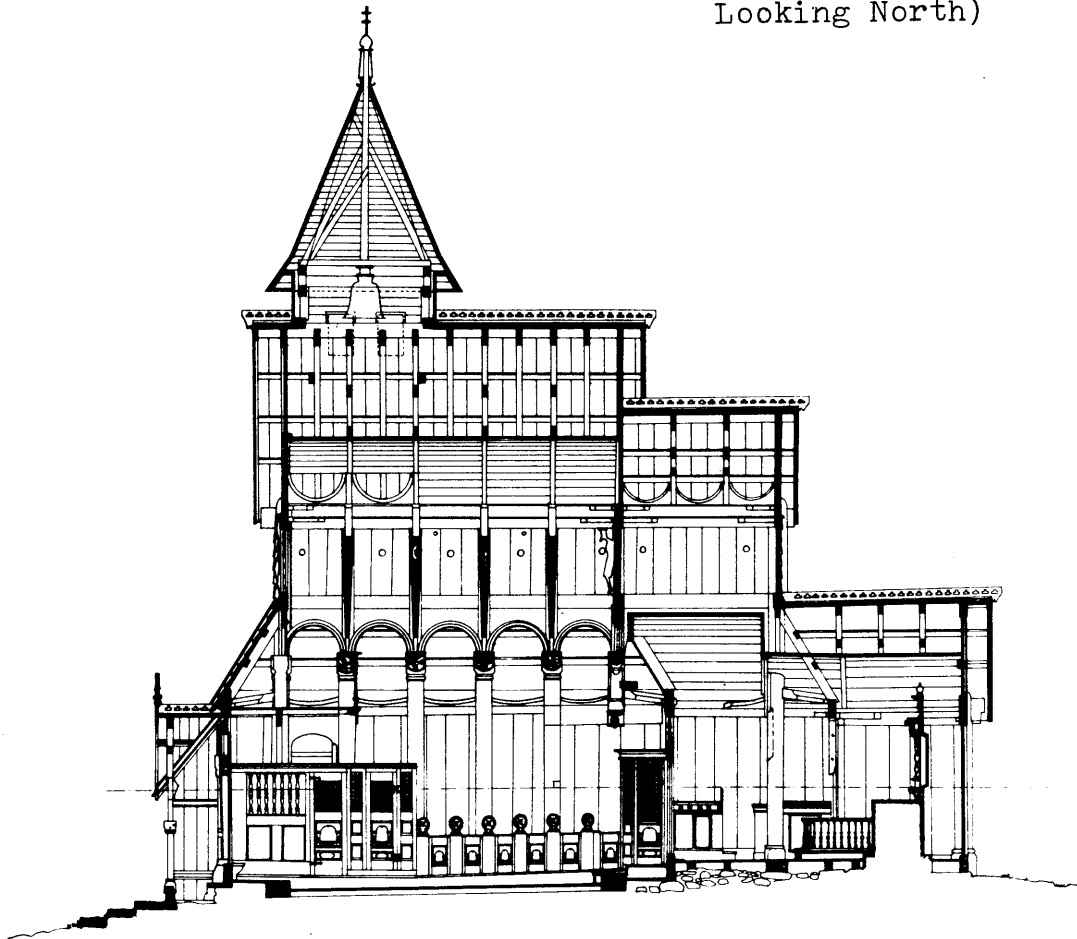

The Urnes Stave Church is believed to have been built in about the year 1160. It stands on the same site where one and possibly two other earlier stave churches stood. Excavations underneath the present church revealed that members of the present sill were used in an earlier church. Also, underneath the church, remnants of posts sunk directly into the ground were discovered (evidence of a more primitive method of stave construction). The elaborately carved doorway on the north side of the church (see pages 93 and 95) is believed to have come from the main entrance on the west side of an earlier church. The tent roof that houses the bell was added to the church shortly after the Middle Ages. The pews were also built after the Middle Ages.

The Gol Stave Church
(Plan)

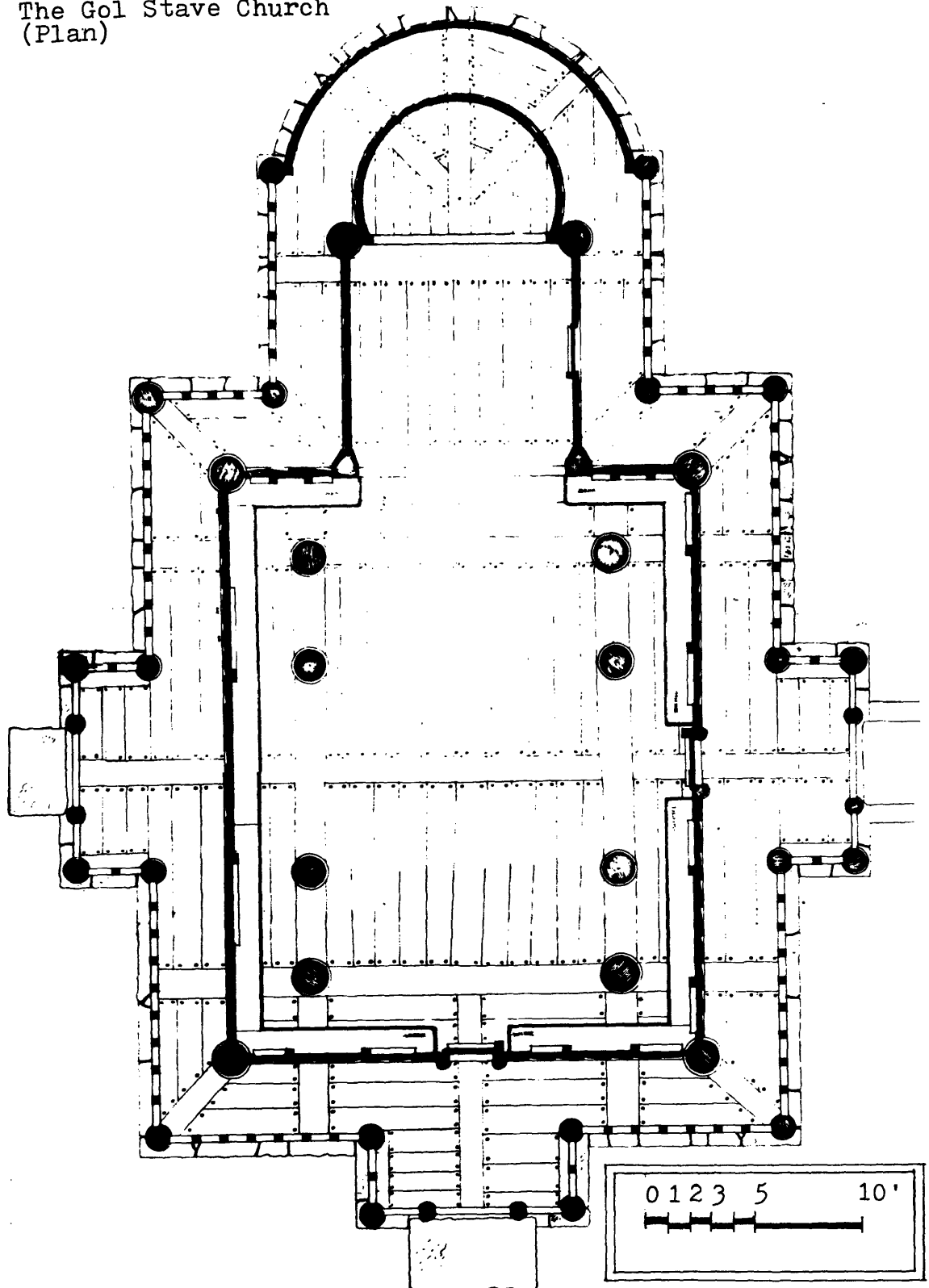

With its free-standing columns, a complete ambulatory and a semi-circular apse, the Gol Church represents one of the final stages of stave development.

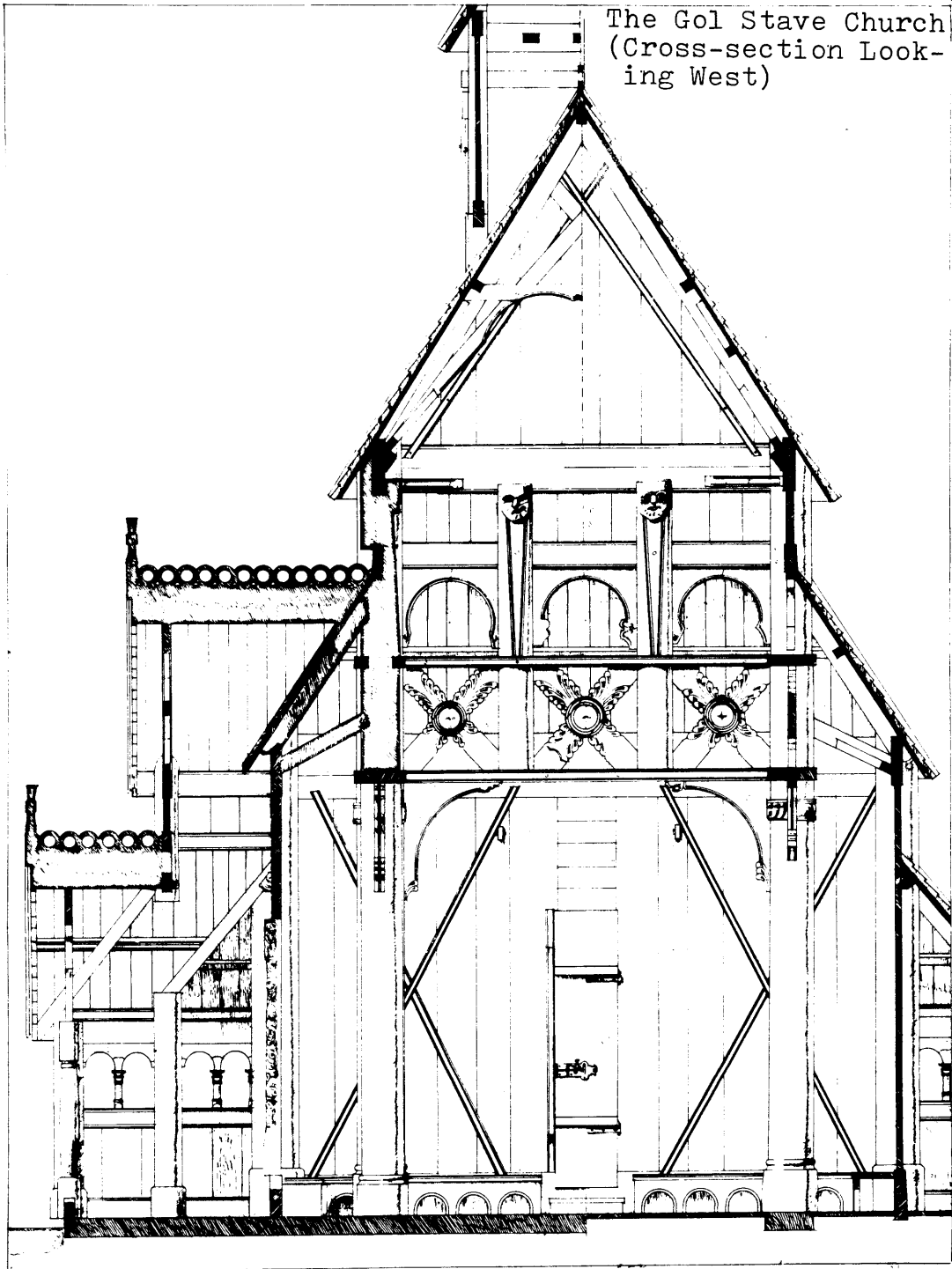

The stave designers had come a long way from Holtdalen by the time they designed the Gol Stave Church, and they exhibited a marked talent for engineering in wood. By developing a very elaborate bracing system that transferred loads to the corner columns, the designers were able to terminate the middle columns before they reached the floor, thereby freeing-up extra space for the nave.

The Gol Stave Church (Longitudinal Section Looking North of the Western Portion of the Church)

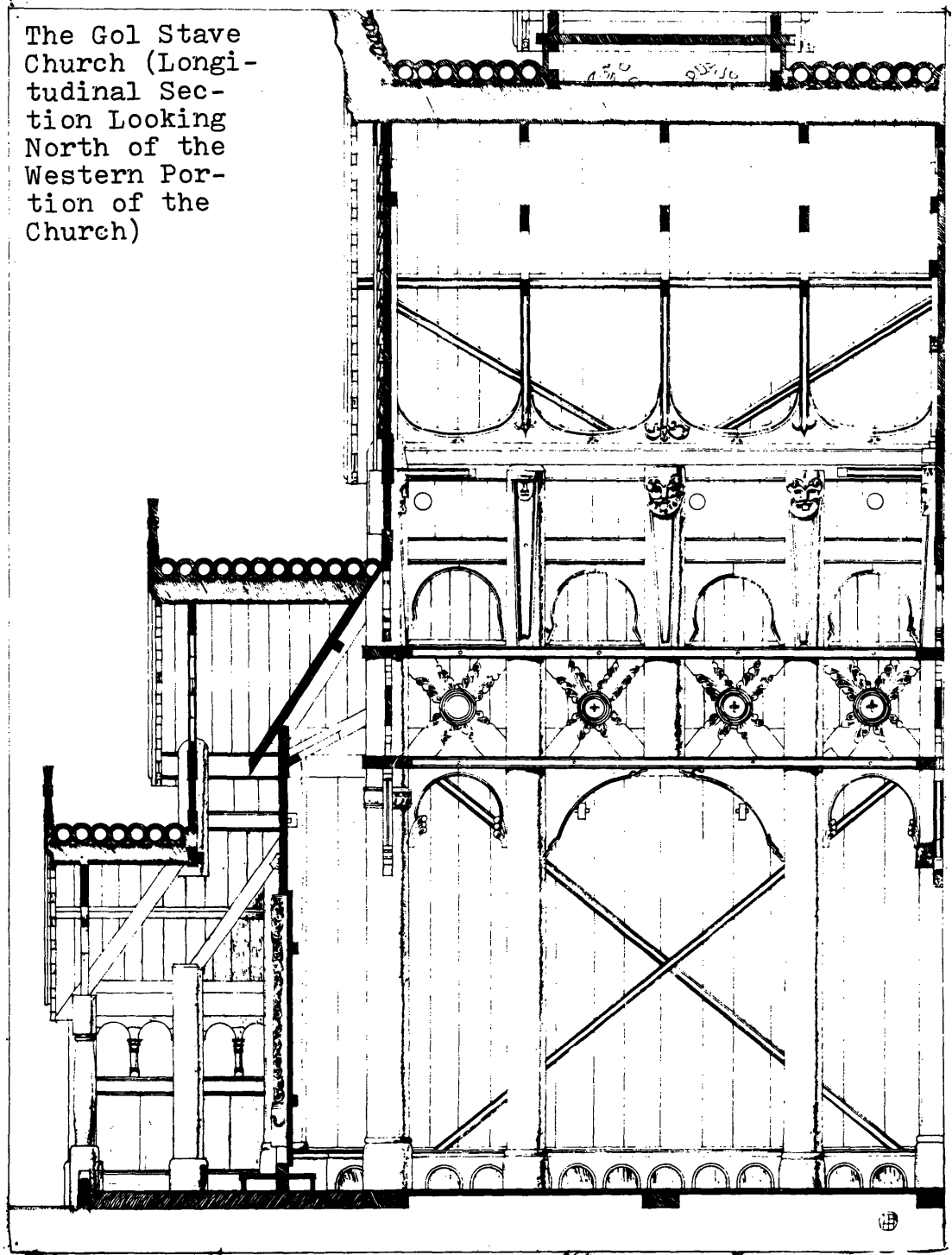

The tops of the free-standing columns were used for carving masks. Many believe that these heads represent important figures from pagan Nordic religions worshipped by the Norwegians before the introduction of Christianity in about the year 1000.

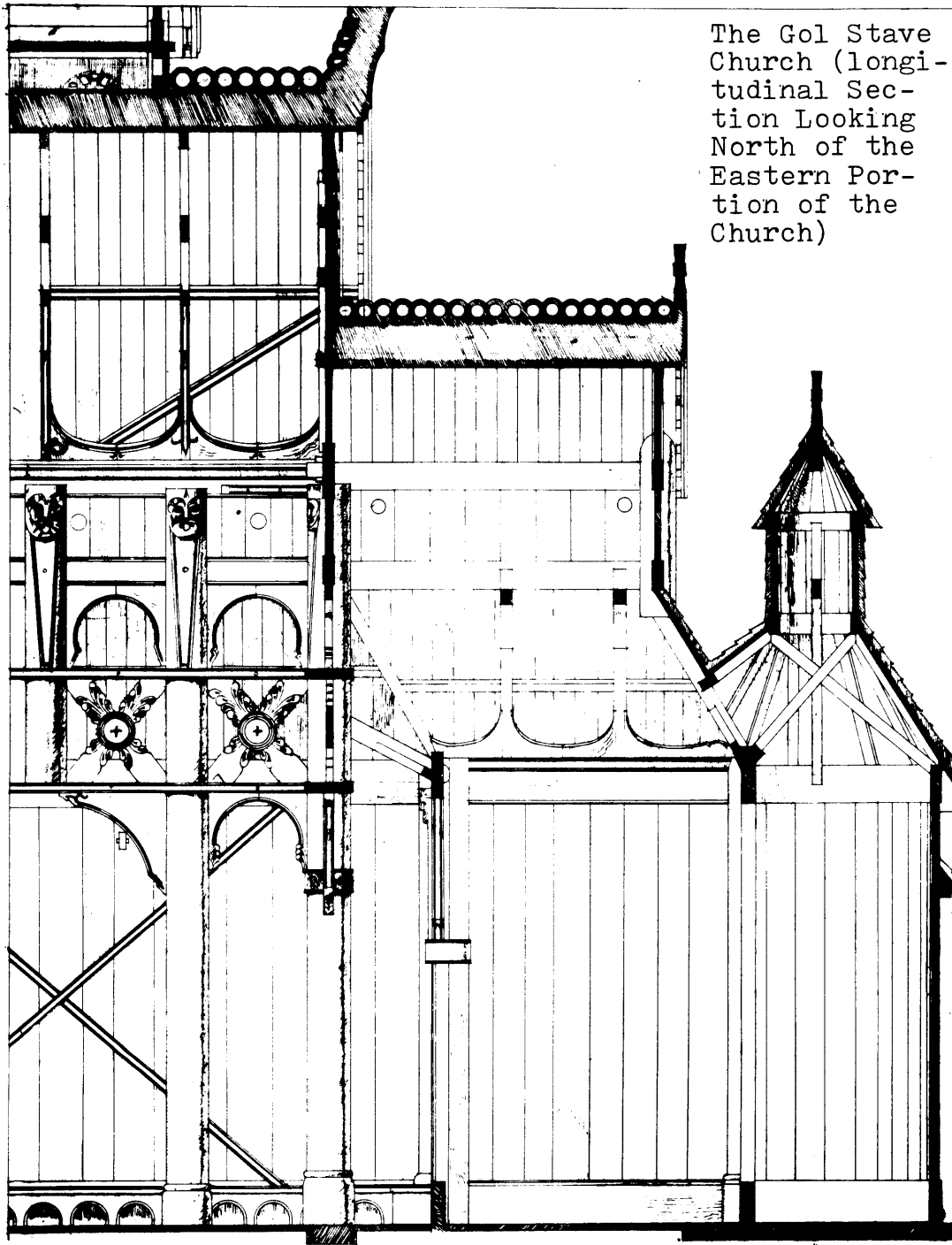

The Gol Stave Church (longitudinal Section Looking North of the Eastern Portion of the Church)

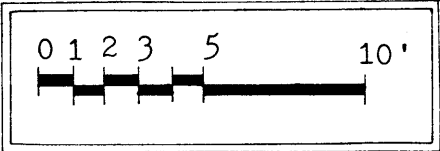

The word "stave" is used to refer to the planks that make up the exterior walls, the corner posts for those walls, or the free-standing columns of the nave and chancel.

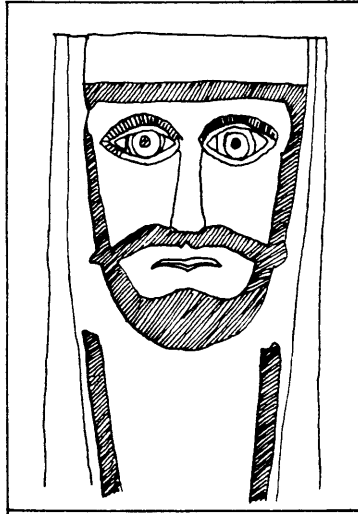

Depicting, perhaps, a Nordic god, this head is carved at the top of one of the free-standing columns of the Hurum Stave Church.

The Stave Technique of Building

In English the word "stave" is used to refer to the narrow strips of wood that form part of the sides of a barrel or tub. This sense of the word "stave" is very similar to the Norwegian usage. The Norwegian word "stave" can refer to three different parts of a stave church. It can mean the vertical planks that make up the walls, or the heavier corner posts of those walls. Alternatively, it can refer to any free-standing column in the interior of the church.

Hundreds of years before the stave churches were built the Vikings were using the stave technique for joining timbers. On display at the Viking Museum in Oslo is a funeral "house" built in the stave technique. This is the oldest of all known stave constructions, and its poor craftsmanship is due in part to the fact that the structure was built on the same day as the Viking queen's cremation. Another similarity between stave church construction and Viking shipbuilding is that the staves in the walls of the churches are connected to each other with a ship-lap joint similar to the one the Vikings used to connect the planks on the hulls of their ships.

Though Norway has almost all of the remaining stave churches, there are a few in other countries. Sweden has two stave churches: Hedared and Gotland. England has one in Greensted, which is believed by some to be the oldest of all wooden buildings in Europe. There is a Norwegian stave church that was moved to a German town, which has

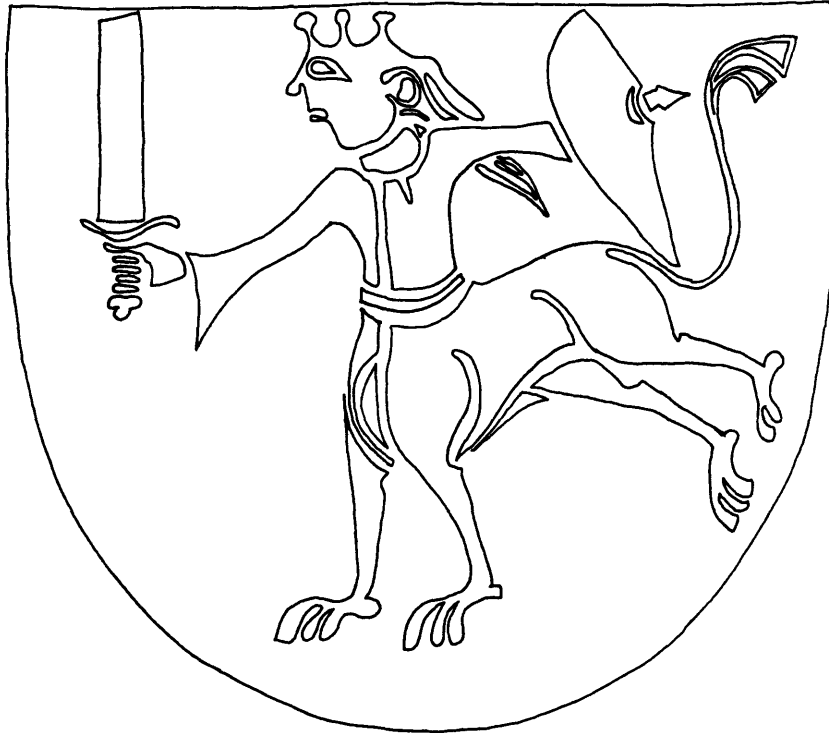

Centaur carved on a capital at the Urnes Stave Church

since become part of Poland. The archeological finds of the remains of stave constructions show that stave churches were built on the same site where stone churches now stand. The excavation of the stave church in Lund, Sweden (formally part of Denmark) is an example of a stave church that was replaced by a stone one. Stave constructions have also been excavated as far west as Iceland, and as far south as Switzerland. The numerous archeological sites which include stave finds is strong evidence that stave construction was at one time widely practiced throughout Europe.

Stave construction is an improvement over the more primitive building technique known as palisade construction. This method is similar to stave construction because walls are made with vertical timbers. The difference between the two is that in palisade construction the vertical timbers are sunk directly into the ground, whereas in all but the earliest stave constructions, the bottoms

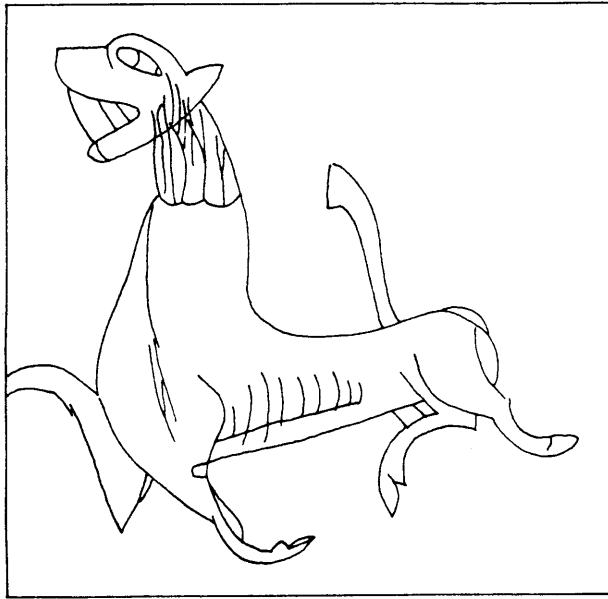

This lion (?), carved with the tip of a knife in a stave at the Lom Church, is one of the hundreds of graffiti-like drawings that decorate the stave churches.

of the stave are received into a grooved sill. Another early version of wall building, which is also an ancestor of stave construction, is the wattle method in which timbers are placed vertically in the ground. Enough room is left between the standing timbers to weave branches horizontally. Typically, mud is applied over the branches to finish the wall.

The stave technique is also related to another more advanced wall building technique known as half-timbered construction. In both methods a rectangular frame is made of heavy timbers. The principal difference between the two is that in stave construction the frame is filled in with wood, whereas in half-timbered buildings another material (usually masonry) is used. What often determined the choice between the two methods was the availability of large dimension lumber. Corner-timber construction, which is commonly seen in log cabins, is almost the exact opposite of stave construction. In log cabins the timbers

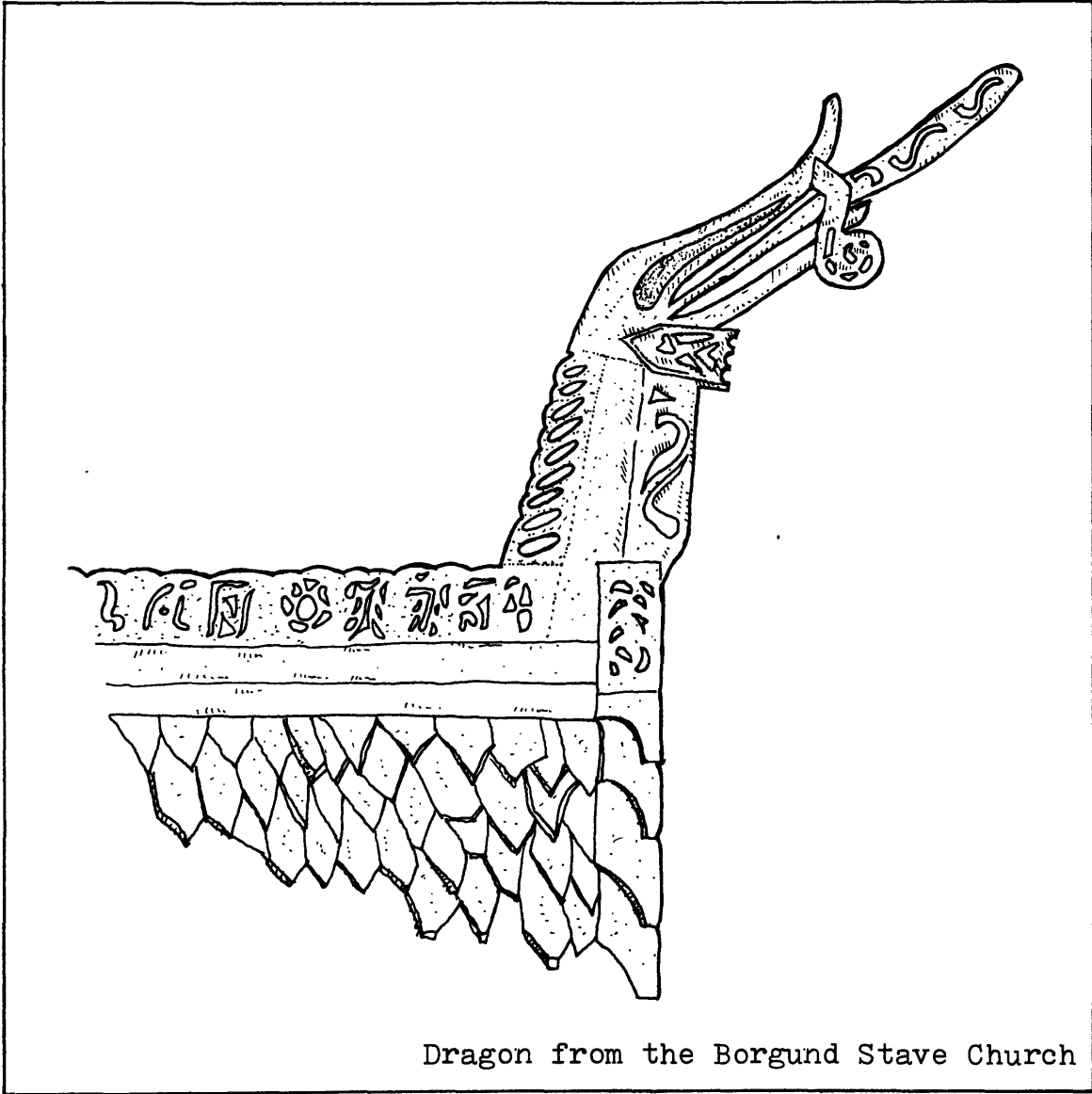

Dragon from the Borgund Stave Church

run horizontally and there is no hierarchy between a framework and a system of infill. The stave technique is believed to have originated in northern Europe, while the corner timber technique is thought to have come to Europe from Russia.

The present day method of wood frame construction is similar to stave construction. The medieval stave wall with its corner posts, sills and vertical staves resembles the stud wall with its top and bottom plates and its vertical scantlings.

Preparing the Wood

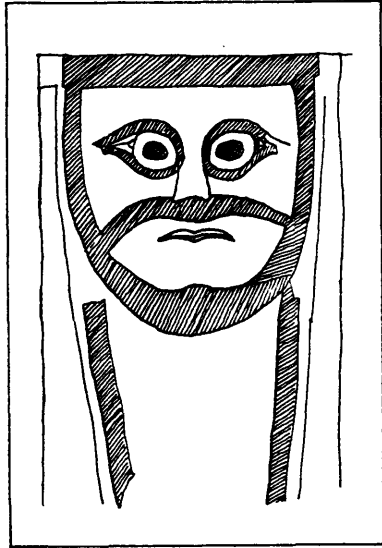

This mask is carved into the top of one of the free-standing posts in the nave of the Hurum Stave Church.

The story of the construction of the Torpo Stave Church began years before the actual carpentry. The first step was to prepare the timber. To obtain the highest quality wood the carpenters went into the forests and selected the tallest and sturdiest pine trees. The Norwegian pine tree is different from the pines commonly found in North America. The pine they used is both harder and redder.

Except for some oak, which can be found in the Urnes Church, all of the stave churches were made exclusively of the Norwegian hard pine. Once the most suitable trees were selected, the carpenters began to harvest them by climbing up the trunks and cutting off the tops. On the way back down the branches were chopped off. For as long as ten years, depending on the size of the tree and weather conditions, the tree trunks were left standing in the ground. This method of farming the trees allowed the sap to drain slowly down into the roots. The carpenters must have developed this technique based on the experience of rapid and uneven drying which inevitably cracks and splits the timber. The slow cure method they developed was so effective that they were able to obtain large wooden members that were nearly free of surface defects. It was only shortly before construction that the trees were felled. An added advantage of this drying technique was that the dry tree trunks were much lighter to transport to the building site.

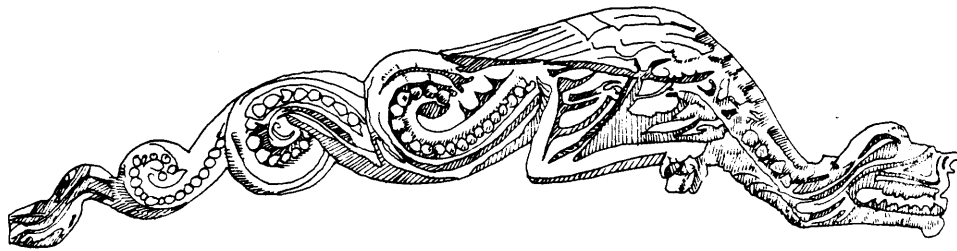

Carved dragon from the Kaupanger Stave Church

After cutting down a tree, the carpenters dug up the stump and roots. The part of the stump that curves into the roots was saved to make the curved knee braces. The tight grain of the stump wood was well suited for bracing stock. The remainder of the root system was collected because it contained high concentrations of the sap that had drained down from the trunk of the tree. The roots were placed in a large pile and through a process of slow burning, they were converted into charcoal. As the roots were converted into charcoal, the sap turned into a black tar, which was extracted and stored for later use.

Once the construction of the stave church was complete, the black tar compound was applied to all the exposed wood surfaces. The thick black compound softened under the intense heat of the Nordic summer sun. The liquid tar penetrated into the pores of the pine, impregnating the wood with the same sap that years before had helped the tree grow. The black sap created a thin film which effectively protected the wood from the elements. Eventually the heat of the sun would break down the compound, and a new coat would have to be applied.

THE STONE FOUNDATION AND THE PRIMARY SILL

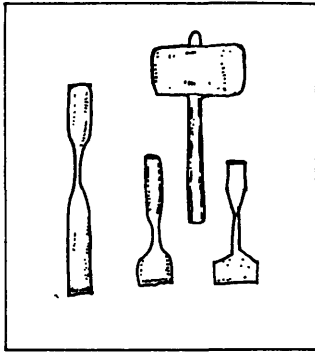

Hammers and chisels were used for cutting the foundation stones. Judging from their work, the Norwegian craftsman felt more comfortable using these tools as a carpenter than as a mason

The construction of the Torpo stave church began with the foundation, the only major portion of the building that is not made from wood. The short foundation walls are made from roughly cut or uncut stones gathered from nearby fields. No mortar was used to hold the stones together, and no metal ties have been found anchoring the sills to the foundation.

Aligned along an east/west axis, the foundation resembles a tic-tac-toe grid inside a larger rectangle. This shape corresponds directly to the wooden structure it supports. The foundation not only provides a continuous support for the sills (which eases the transfer of the building's weight into the earth), but it also raises the wooden members above the ground, thereby avoiding the harmful effects of the soil's humidity.

The first wooden members that are set in place are the four primary sills. As these four members are being assembled together in the shape of a tic-tac-toe grid, the two floor joists are fitted into mortises cut into the inner sides of the two longer primary sills. All of these members are oriented with their broad side horizontal. The primary sills are very sizable pieces of lumber; made from heartwood pine, they measure sixteen inches by twenty inches by approximately thirty feet.

THE STONE FOUNDATION AND THE PRIMARY SILL

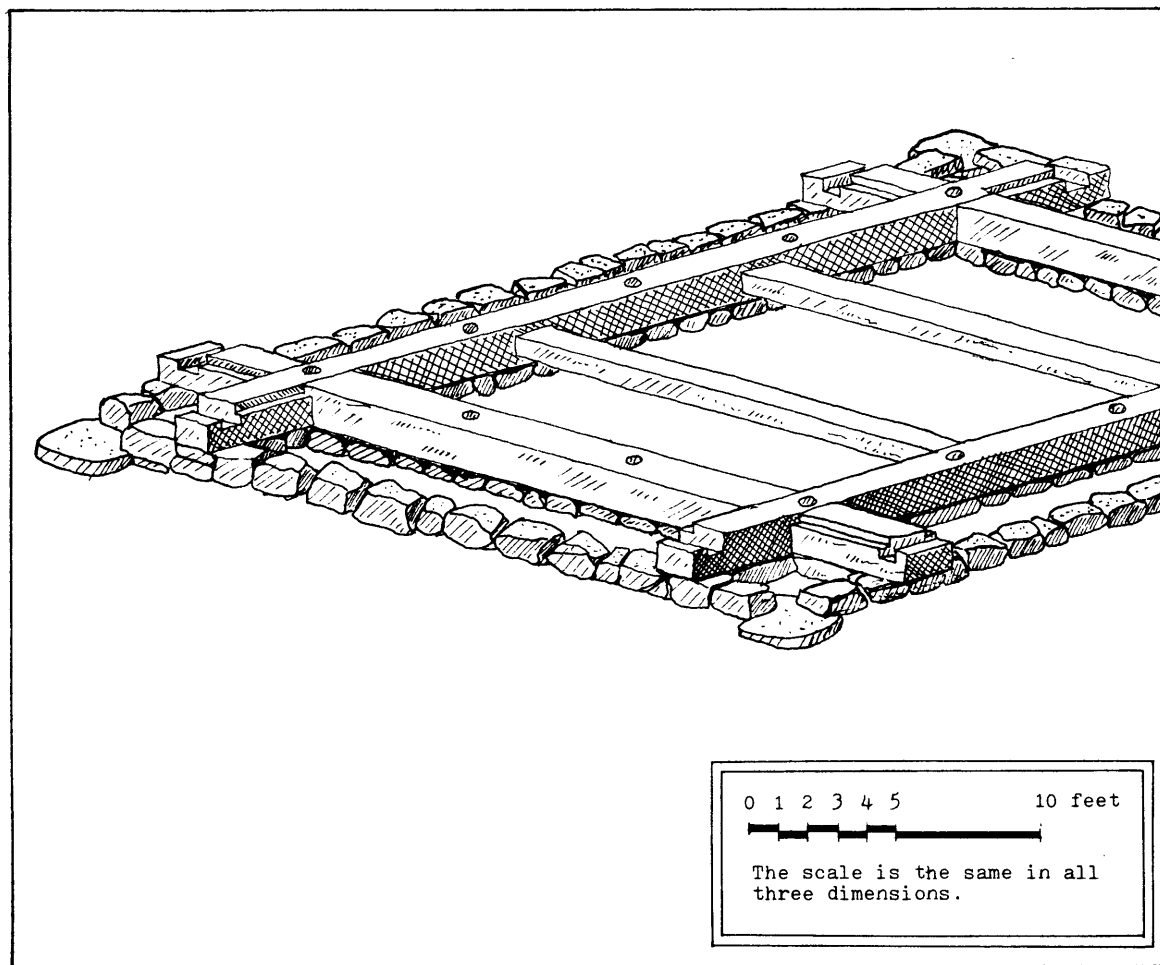

Connected in the form of a tic-tac-toe grid, the four primary sills are raised above the ground and protected against the detrimental effects of the soil's humidity.

We know from archeological excavations that the earliest stave churches did not use a sill or foundation. Instead, wooden members were set in post holes. The disadvantage of sinking the wood directly in the ground was that moisture in the soil slowly disintegrated the posts. As a consequence buildings which employed this method of construction collapsed after about one-hundred years. The sill and the stone foundation represent a major improvement over the earlier designs, and this design change is one of the reasons that a handful of the stave churches have survived to this day.

JOINTS OF THE PRIMARY SILL

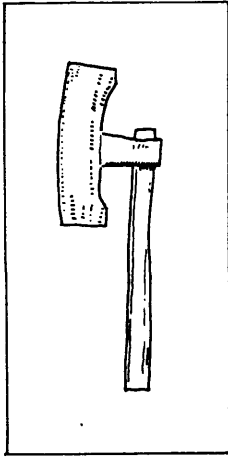

The axe was the Norwegian carpenters most useful tool. It was employed not only for felling trees, but also for the accurate cutting of wooden joinery.

The primary sills serve four functions: First, they receive the weight of the roof via the columns and pass it along to the foundation. Second, they support the secondary sills which carry the outside walls. Third, the sills support the floor; and fourth, they serve as part of the finished floor. Each of these functions has an influence on the form of the sill.

The sills exhibit a number of specialized wood joints. The Norwegian carpenters devised a variety of ingenious ways to attach wooden members to the sills, ways that provide a secure connection and a means for the smaller members to transfer their loads to the sill. The specific wood joints of the sill are as follows: Rectangular mortises are cut into the side of the longer sills. Into these mortises the ends of the floor joists are wedged. Ledges cut into the upper corners of the sills support the ends of the floor planks. The round holes are designed to receive the columns that stand on top of the sills. The sills are fastened to each other at the intersections with a half-lap joint. This joint allows the sills to extend past each other while they simultaneously maintain the horizontal plane of the floor. The intricate detailing at the end of sills interlocks with the secondary sills and prevents them from slipping out of place. The finesse of these connections is missed by most observers because the joints can hardly be seen once the pieces are connected together.

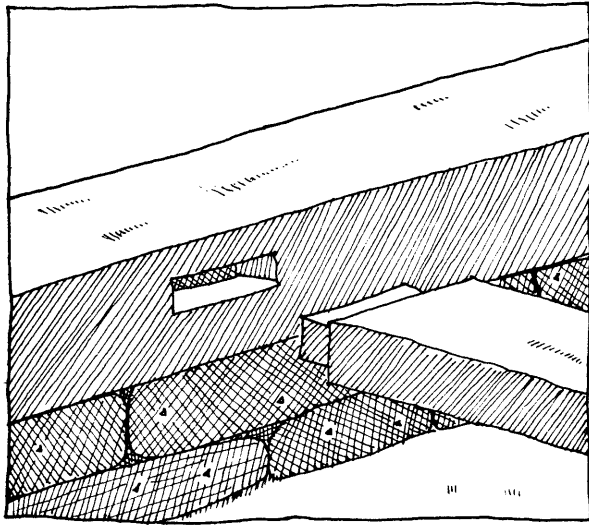

JOINTS OF THE PRIMARY SILL

A tenon carved on the tip of the floor joist fits into a mortise cut into the inner side of the primary sill. Because the floor joist was of such large dimensions, it was capable of spanning between the sills on its "face" (narrow side vertical) without causing a floor deflection problem.

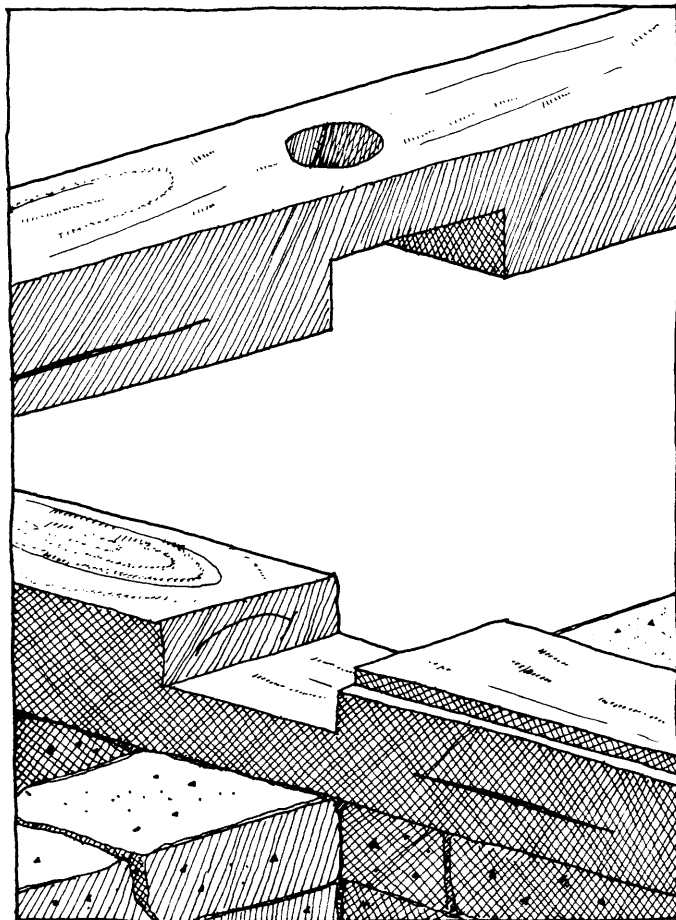

The primary sills are attached together with a half-lap joint that prevents either member from slipping out of position. The round hole cut into the top of the sill is designed to hold one of the free standing columns, which is inserted later.

THE SECONDARY SILLS AND THE CORNER POSTS

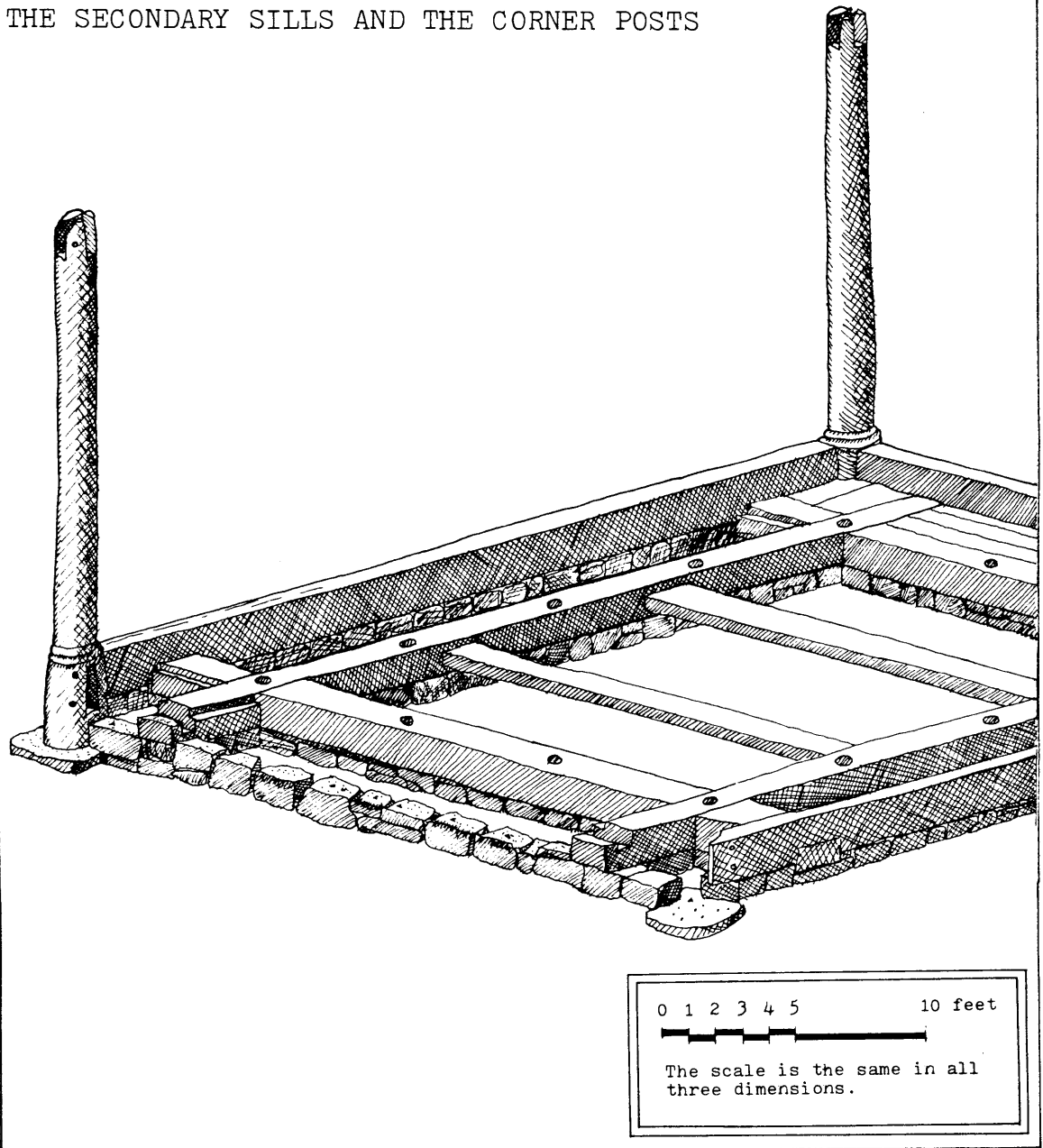

The large (one foot by two feet) horizontal members, which line the lower edge of the building, are the secondary sills. Their main function is to support the stave walls that will come later. The secondary sill rests on its own stone foundation and is connected to both the primary sill and the corner posts. The interlocking connection of the primary and secondary sill prevents either member from slipping out of position.

THE SECONDARY SILLS AND THE CORNER POSTS

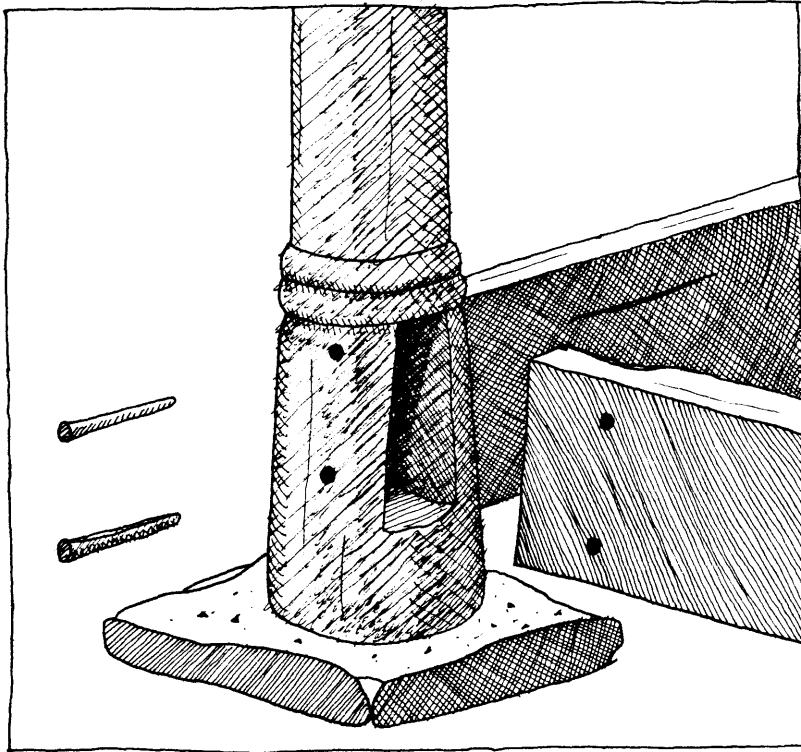

The ends of the secondary sill are attached to the base of the wooden columns. Two wooden pegs lock the members together.

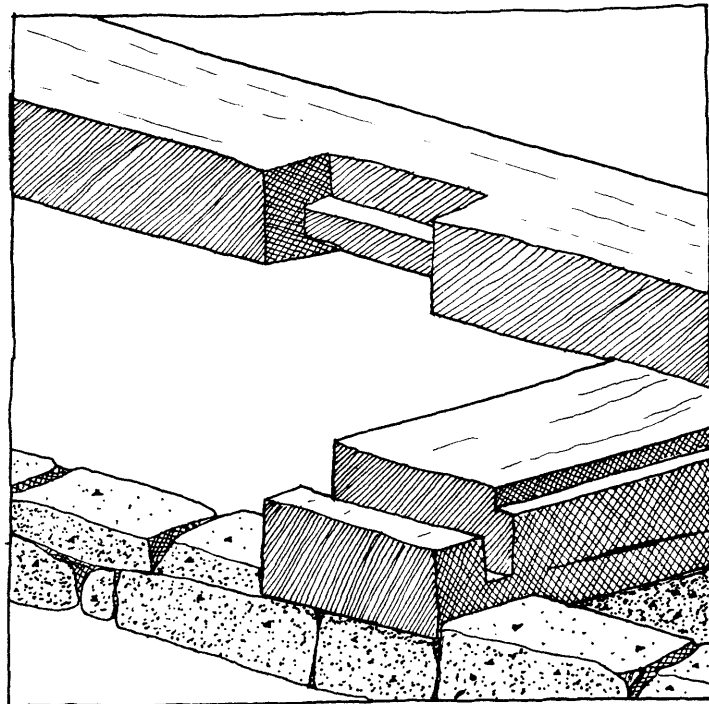

The secondary sill connects to the primary sill. The secondary sill has been raised and rotated to reveal the detail of the wood joint.

THE FLOOR PLANKS

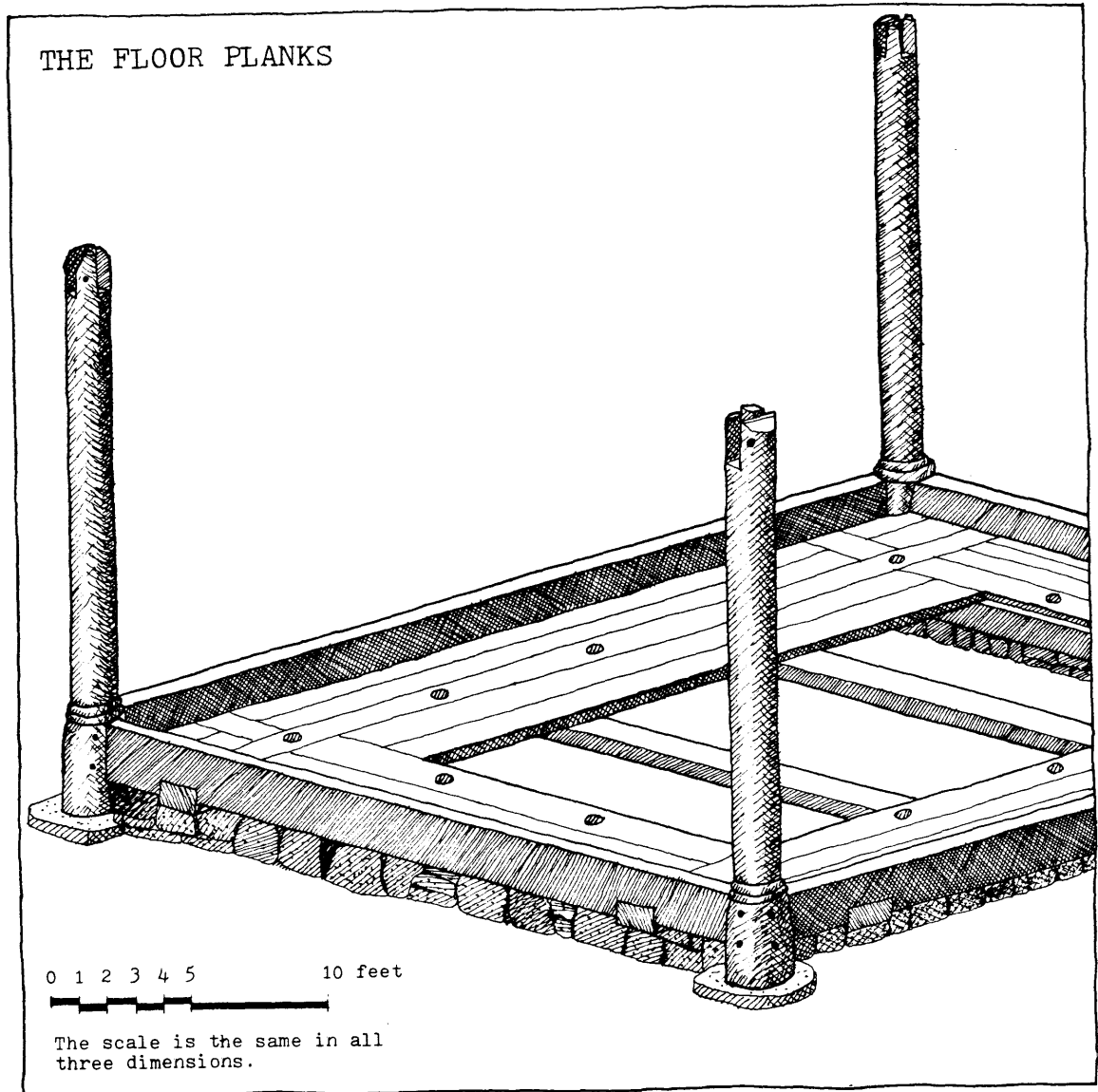

Once the sills and the four corner posts were in place, the carpenters began building the floor. Planks twenty-four inches wide were cut to the exact length needed to span between primary sills, and they were then placed in position on top of the floor joists. Ledges in the primary sill received the ends of the planks, and this joint created a flush fit across the top of the plank and the primary sill. This joint both enabled the sills to serve as part of the finished floor, and allowed the planks to transfer part of their load directly into the sills.

THE FLOOR PLANKS

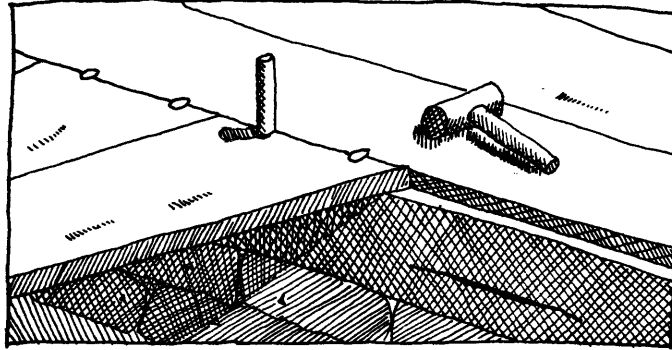

In the Gol Stave Church the plank to sill connection was executed in a slightly different fashion. By using thicker planks, thinner dowels, and by angling their entry, the carpenters were able to achieve a more secure connection, which at the same time avoided splitting the planks.

Wooden dowels hold the floor planks to the primary sill. The carpenters chose to drive the dowels through the very tips of the planks. By catching only the end of the planks, the risk of splitting the wood was held to a minimum.

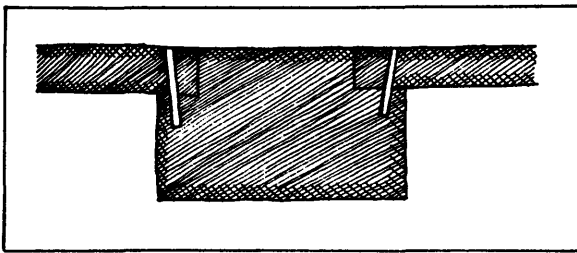

A pair of wooden dowels is used to tie the planks to the floor joists.

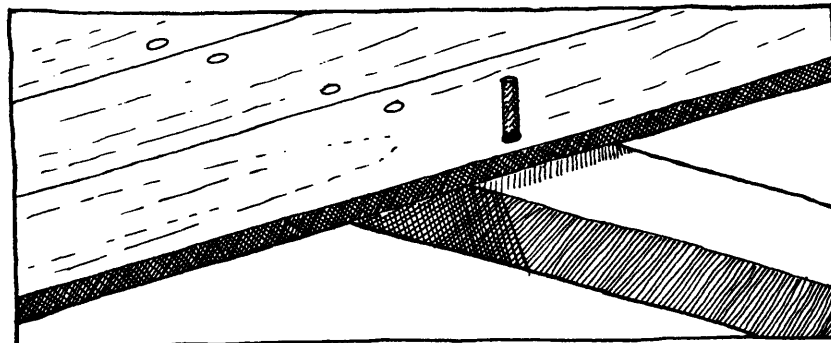

THE FLOOR

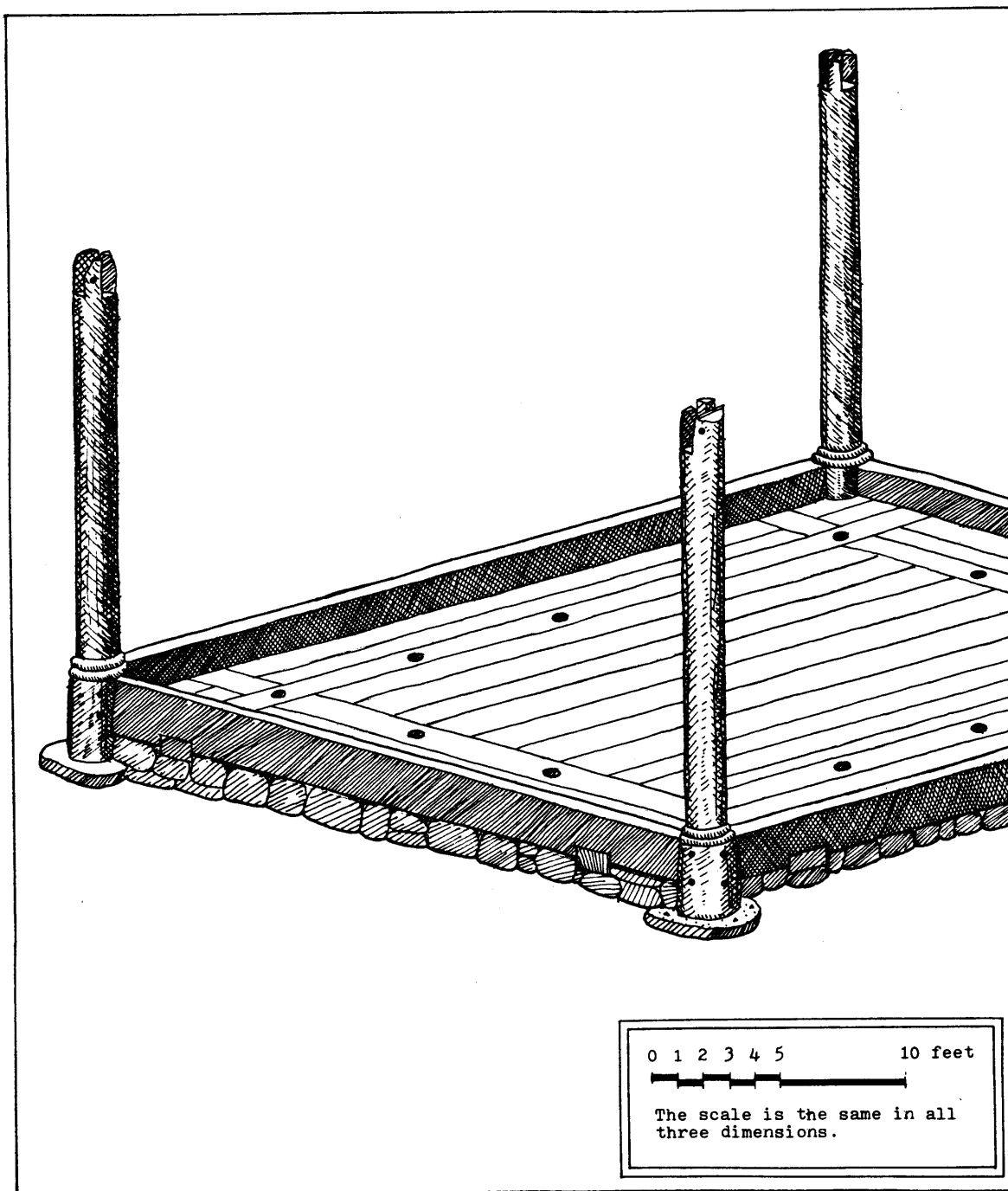

The floor of the Torpo Stave Church measures twenty-five feet by thirty feet, and stands two feet above the level of the ground. The round holes in the floor mark the spots where free-standing columns will be inserted.

THE FLOOR

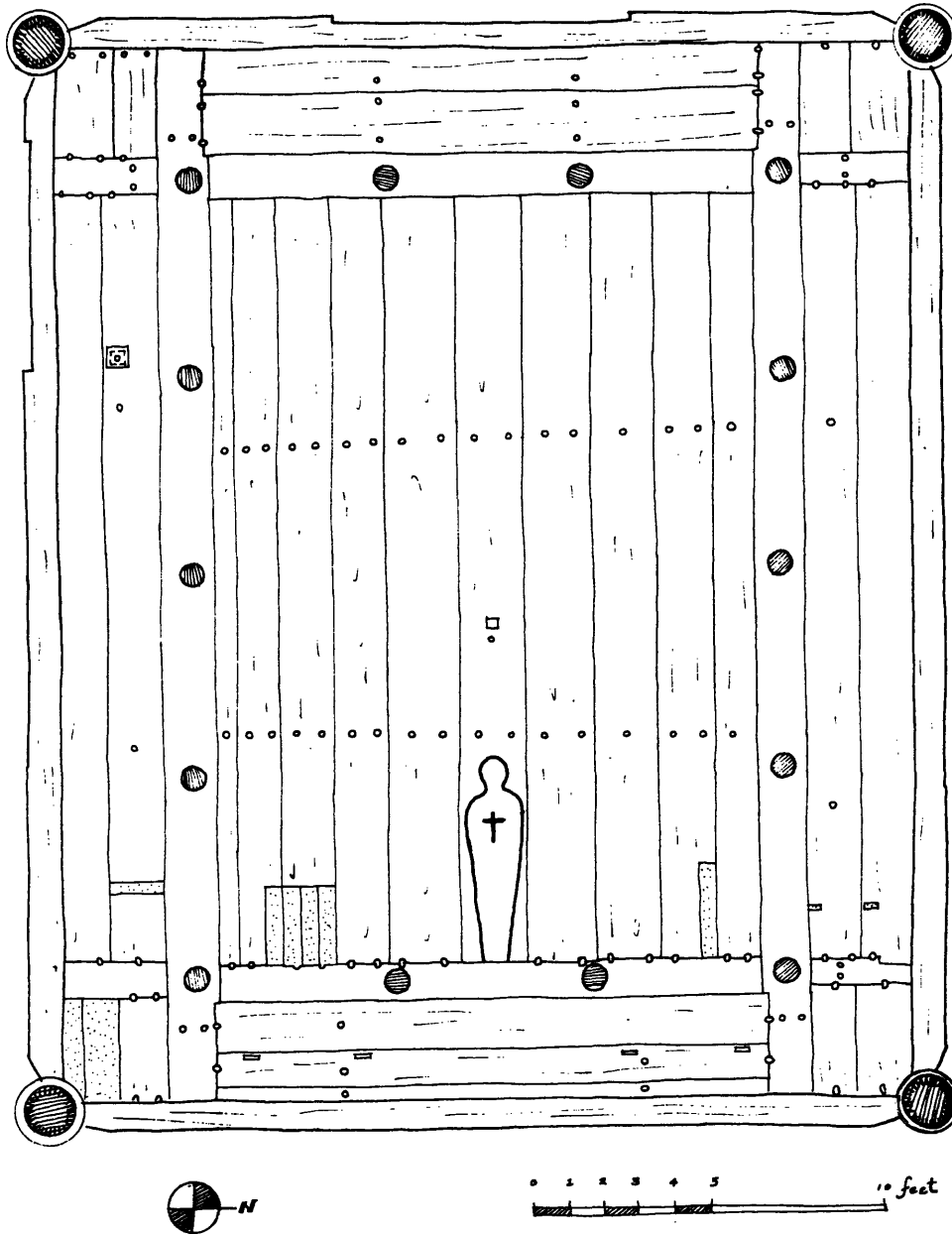

One advantage of pegging the floor planks was that it allowed for the possibility of removing them at a later date. Sometimes the ground below the floor was used for burying the dead. The figure outlined in the central floor plank of the nave marks the burial site of an important religious dignitary. The dotted portions of the floor indicate members that have been used to repair or replace the original flooring.

THE COLUMN WALL

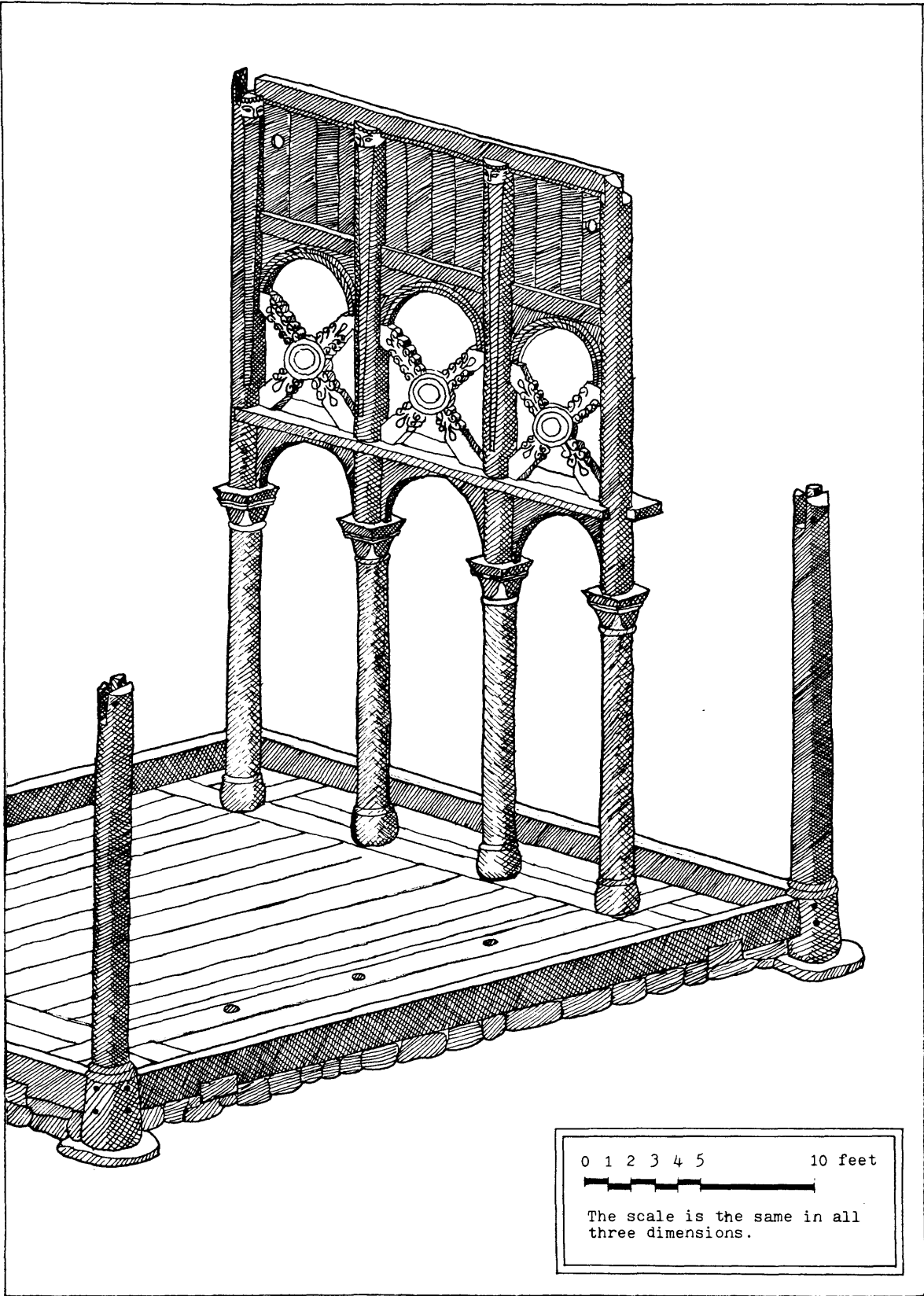

At the top of the columns are carved heads which support the horizontal top sill. It is a commonly held view that these heads portray the Nordic gods worshipped by the Vikings. Though it is not known which god is represented in this example, it is perhaps Thor, god of thunder, or Frey, king of the gods. Even though they are no longer worshipped, Thor and Frey have managed to live on in our language in the words Thursday and Friday.

THE COLUMN WALL

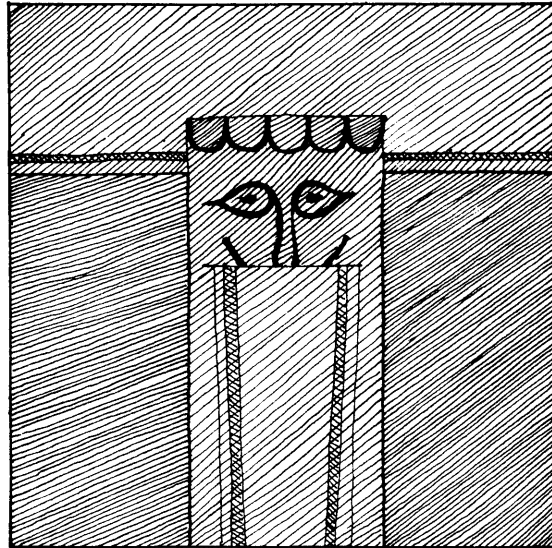

The column wall is an assembly of two kinds of arches, clamp and cross braces, and a clerestory. Because of its structural integrity, it was possible for the carpenters to assemble the column wall on the ground, and then, with the aid of about a dozen men and a number of special hoisting poles, to lift the column wall in one piece to its standing position. As the column wall was being raised into position, it was necessary to guide the "nose" underneath the base of each column into its corresponding hole in the sill.

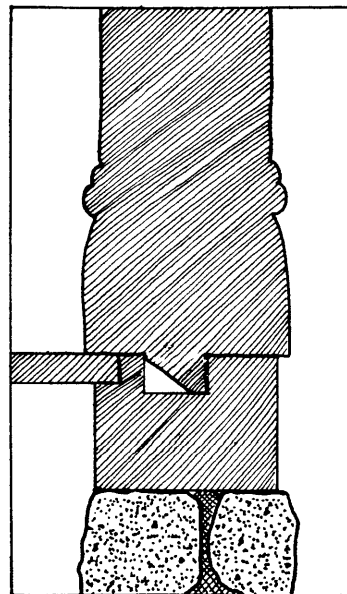

The "nose" at the base of each column is designed to help guide the column into a corresponding round mortise in the top of primary sill. Once in place this joint prevents the column wall from sliding out of position.

BRACING THE COLUMNS

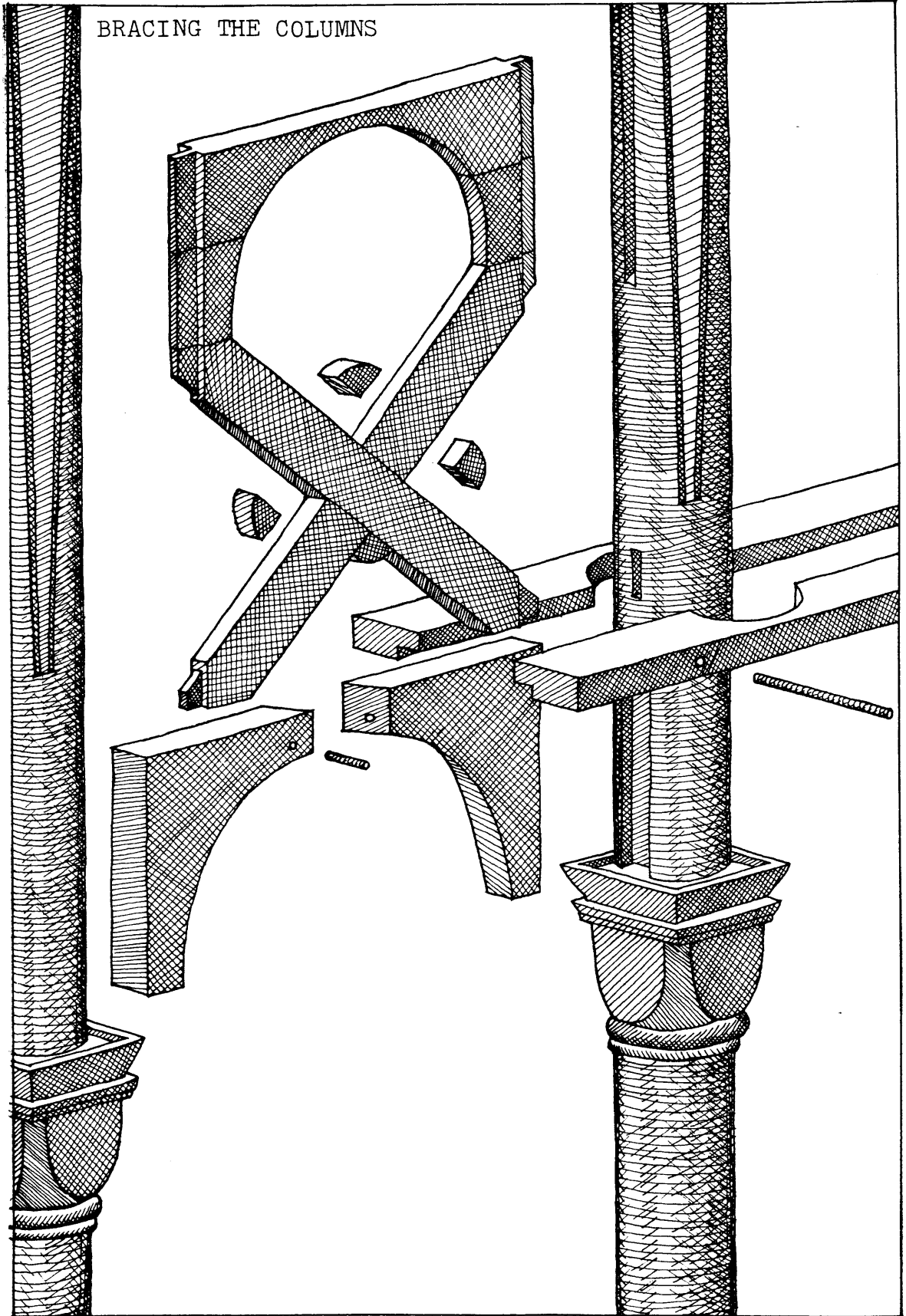

BRACING THE COLUMNS

In the next several pages a close examination will be made of the wooden braces that make up the column wall. The wooden braces are part of a carefully conceived design that has been executed with great craftsmanship. Since all of the braces connect to the column, we begin our inquiry with a look at the column both as a structural and as a decorative element.

What appears to be a column capital is thought by many observers to be an architectural device that allows two short columns to be joined together. However, this is not the case. Cut from very tall pine trees, the thirty-two foot tall columns are made in one continuous piece. The cube capital serves mainly a decorative role, and it is generally believed by most scholars of the subject that the design of the cube capital was heavily influenced by European Romanesque stone architecture. The cube capital's only structural contribution is that it provides a ledge for the knee braces to stand on. The square bands that decorate the top edge of the cube are not part of the column, but are made from mitered moulding that is applied to the cube. Between the two converging lines in the upper story, the normally round column has been shaved flat. As the lines diverge towards the top, the planed surface cuts deeper into the column. This "V" shape decoration terminates at the "chin" of the carved masks.

The drawing on page 58 depicts the wooden braces that make up the column wall. The upper arch, which I call the "plank" arch lies directly above the St. Andrew cross. Underneath the cross is the clamping brace, which has been "cut" to show its cross-section. Below this is the arch commonly termed the "knee brace arch." With the exception of the clamping beam, the braces connect to the column by means of a tongue and groove.

WOODEN BRACES

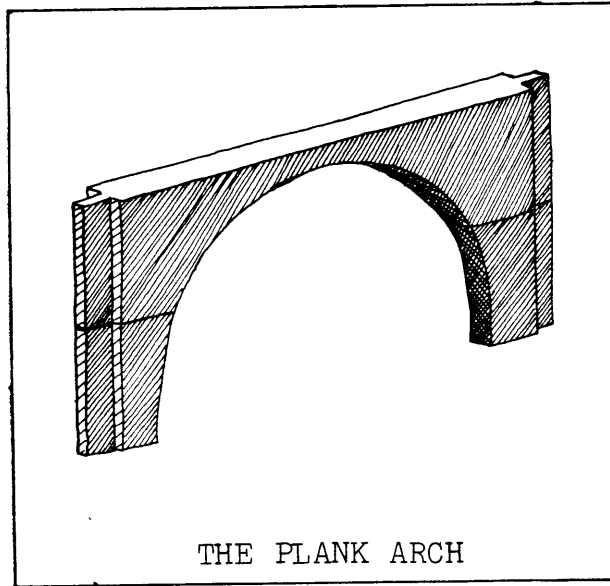

The three and one-half foot wide arch is cut out of horizontal boards. The upper plank is almost five feet long, sixteen inches wide, and three and one-half inches thick. The ends of the planks form a tenon that fits into a slot cut into the side of the column. Pegs penetrate through the curved surface and on into the column.

Because the arch is made from horizontal planks, it has often been assumed that its purpose was purely decorative. However, like a stone arch, the plank arch is capable of carrying weight, and the designers were aware of this, because they employed the plank arch to help bear the weight of the clerestory wall that rests on it. The arch collects the weight from the clerestory and passes it along to the Saint Andrew cross immediately below it. The other structural functions of the plank brace include locking the Saint Andrew cross in a fixed position by preventing it from rising upward in their common mortise. To some extent the upper board of the plank arch resists by going into compression any tendency of the adjacent columns to converge at the top.

In its finished form the plank arch is decorated with three wide black bands. The widest one is on the bottom surface. The other two are thinner and are painted on the surface that faces the nave.

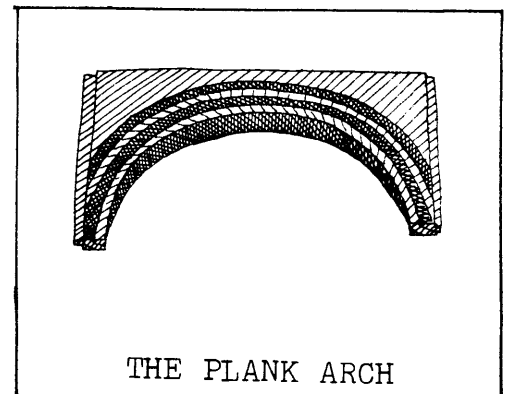

The St. Andrew cross may owe its architectural origins to similarly shaped bracing in half-timbered construction, which is believed to have been highly developed in Europe at that time.

WOODEN BRACES

The cross bracing between the columns has both a structural and a decorative significance. The braces are named after St. Andrew, who was reputedly crucified on a

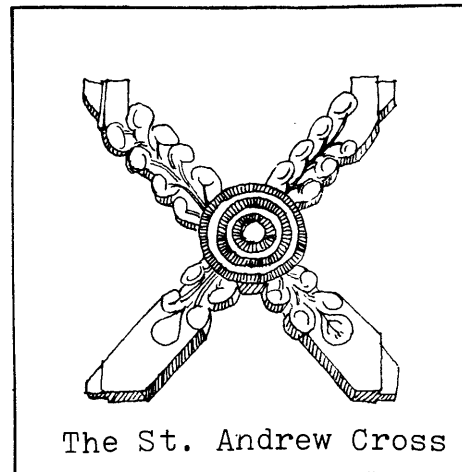

similarly shaped cross. The answer to the question of who named these diagonal braces "St. Andrew Crosses" is uncertain. It may have been the medieval Norwegian builders, the European missionaries, or even someone from a later period. The problem is that no written records have survived which give us any clue of what the cross braces meant to those who worshipped in the churches during the Middle Ages. Still it seems reasonable to claim that they had some special significance for them because these braces are one of the few places in the church where attention is given to detailed carving. The repeated circular forms of the carved braces may represent a plant motif. What connection, if any, this motif has with St. Andrew is unclear.

Whatever the symbolic meaning of the St. Andrew crosses, their structural meaning is clear. Lodged tightly between the columns, the crosses are a very efficient structural form, and because they enclose the nave on all four sides, they help brace the building against lateral forces coming from any direction. The mortise and tenon connection of the brace to the column prevents the brace from slipping laterally out of position. However, since the tenon is not prevented from withdrawing out of its mortise, the brace is capable of working only in compression. Thus, during a wind, only one of the two planks that make up the brace is resisting the force of the wind.

WOODEN BRACES

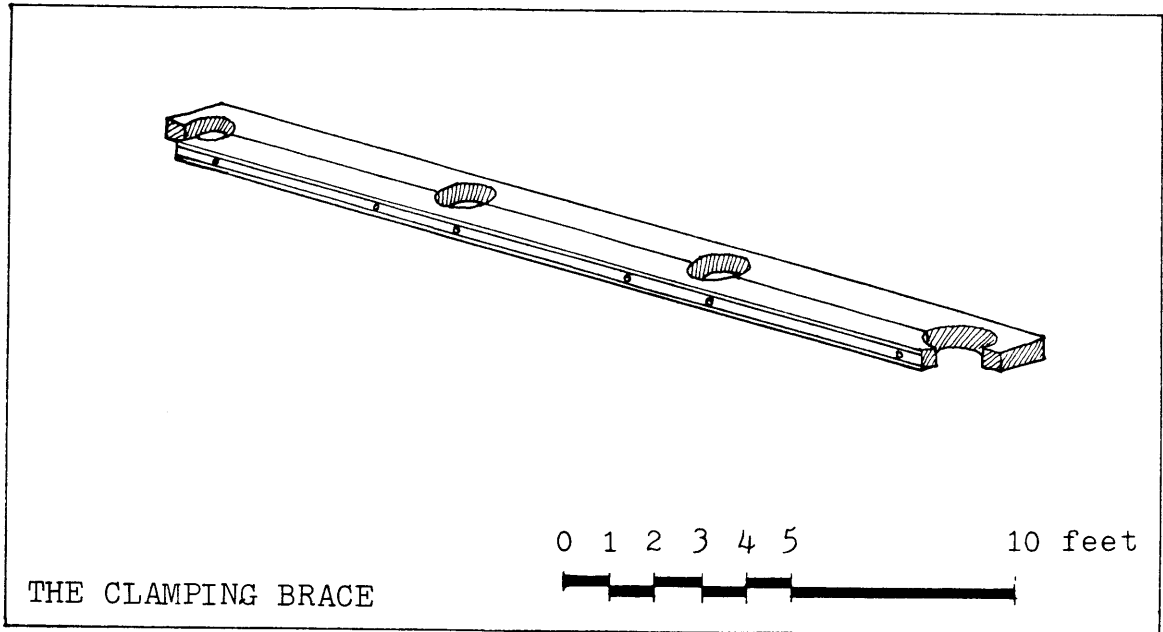

At the critical moment during construction when the row of columns is being raised like a wall into its final standing position, the clamping beam is called into action. The clamping beam helps hold the columns together, allowing them to be raised in a single motion. (This is desirable because it enables the wall to be assembled on the ground rather than in the air.) The role of the clamping beam does not end once the column wall is in position. Not only does the clamping beam continue to keep the columns in line, and prevent the braces from slipping out of position, but it also works in conjunction with the other bracing to resist wind loads.

The clamping beam is made from two planks that have semi-circular holes cut out of their sides. These holes allow the planks' inside edges to fit tightly both around the columns and against each other. Dowels inserted laterally through the planks keep the planks locked into position.

The clamping beam lies just above the curved knee braces and just below the diagonal Saint Andrew crosses. In this position it provides a footing for the Saint Andrew crosses. By providing support for the bottoms of the Saint Andrew crosses, the clamping beams help to transfer part of the load of the crosses into the columns.

The bottom side of the clamping brace contains a rabbet into which the curved knee braces of the arch fit snugly. The rabbet not only prevents the knee braces from slipping out of alignment, but it also counteracts wind loads. As a column bends under the force of a wind, one of the paired knee braces in the arch will tend to tilt up. This upward motion is resisted for the most part by the clamping beam. Because the clamping beam is being asked to bend along its weakest dimension, the designers made the clamp beam amply thick (about four inches) to insure that it would not break under heavy wind loading.

The two planks that make up the clamping beam are held together with dowels that penetrate through both beams. Recesses are cut into the planks so that they can fit around the columns. The rabbet in the bottom of the clamping beam holds the curved knee brace. The wide black lines on the edge of the beam are decorative.

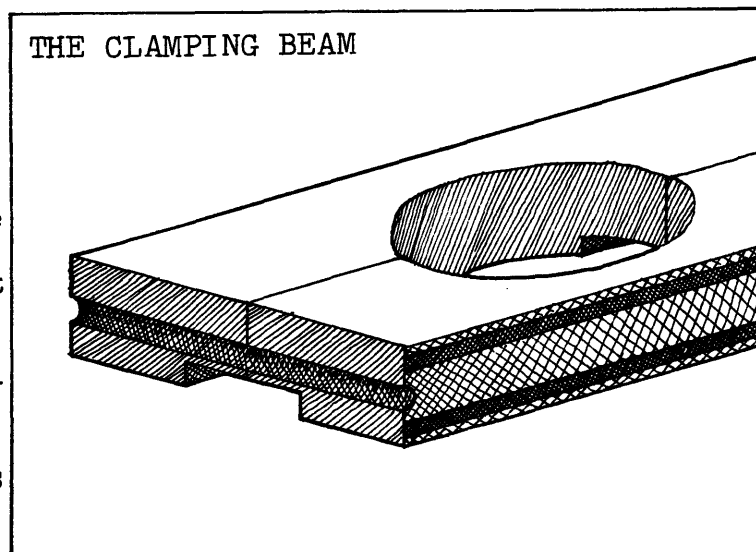

WOODEN BRACES

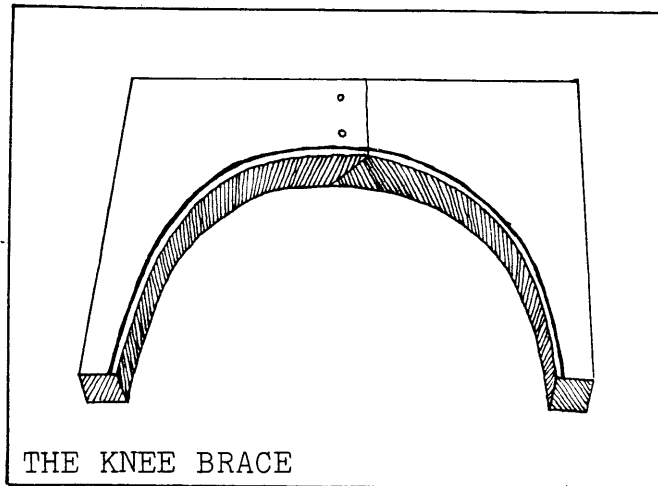

Two knee braces are combined to form an arch. The overlap of the two allows a dowel to penetrate both members. The knee braces are carved from naturally curved pieces that come from the roots of a tree.

The designers of the stave church realized that they needed to stabilize their tall column structure against the wind. In reaching a solution to this problem, the designers took a cue from nature by using almost the same brace nature herself employs to keep trees from falling over. During a storm, the tree trunk transfers the wind loads from the branches into the roots and ultimately into the soil. It is in the base of the tree (where the vertical trunk curves into the horizontal roots) that the greatest stresses build up. To withstand this large flow of forces, the grain of the wood in the base becomes very tight and strong. Realizing that the stump of the tree had both beneficial structural properties and pleasing natural curves, the designers carved braces out of the stumps. Though commonly referred to as a "knee brace", it has also been called a "quadrant bracket" and a "root fork."

THE KNEE BRACE

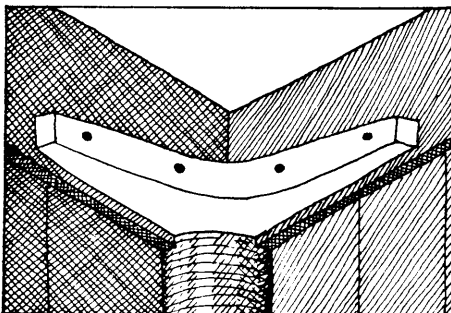

The knee brace not only makes the corner stronger but it creates a pleasing visual transition as well. The knee brace, whose back sides measure from two to three feet, is attached to the corner with dowels. The knee brace is the most frequently employed brace in stave construction. In Torpo alone the knee brace is used eighty-four times.

WOODEN BRACES

Eric Lundberg, the noted Swedish architectural historian, postulates that in "primitive" stave churches, the knee braces were attached to each other to form a three dimensional brace. Located above the aisle, a series of these three dimensional braces connected the top of the aisle wall to the free-standing column. The dashes indicate the location of the dowels; the cross-hatching indicates where the columns are severed (for the illustration).

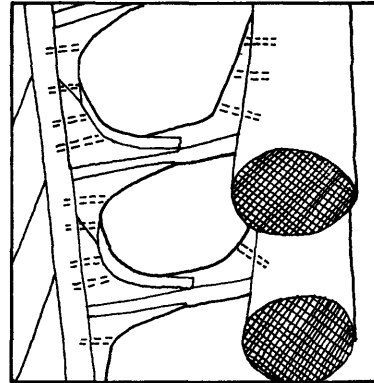

THE KNEE BRACE

The precedent of using naturally curved wood in carpentry was set by the Vikings. It was their practice to avoid steam bending the planks that form the curved hulls of their boats by "finding" the curved planks in the trees. In order to strengthen vital joints in their ships, the Viking boatbuilders made knee braces similar to the ones used by the church builders. However, the Viking knee braces were smaller and were not always carved from stump wood.

Perhaps it is because the knee brace comes from such a long tradition of woodworking that the designers felt very comfortable installing it in many parts of the church. Used in almost every orientation, the versatile knee brace stabilizes the trusses in the roof, the struts above the aisle, the columns in the nave, and the corners of the clerestory. Usually the knee brace is used alone or in pairs, but in each corner above the aisles, three knee braces are connected together. Forming almost a complete circle, they work to stabilize two walls and a free-standing column.

The knee braces are fastened by four dowels that penetrate through the face of the curved side and enter the adjacent member. When extra strength is needed, as is the case with the columns, the knee brace is recessed into a mortise before it is pegged.

WOODEN BRACES

Even though the St. Andrew cross is an efficient structural form for handling lateral loads, the knee brace is in fact more effective. This is because for a given lateral load, the knee brace causes a smaller bending moment in the column than the St. Andrew cross. The reason for this is simply that the knee brace is closer to the base of the column than the St. Andrew cross. Though these two braces perform the major roles in resisting lateral forces, the upper arch, the clamping brace, and the clerestory wall assist them to a lesser extent.

The difference in construction between the two arches reveals that the designers understood a good deal about structural behavior. While the upper arch, which is made from horizontal planks, has little ability to resist lateral loads, it is effective in passing the weight of the clerestory into the columns. In an almost opposite way, the lower arch, which is made of knee braces, handles gravity loads poorly. The arch would have handled gravity loads much better had the knee braces been connected by a butt joint rather than the diagonal splice they have. However such a joint would have been difficult to dowel, and it is the dowels that help the knee braces resist lateral loads. Under lateral forces, the columns tend to tilt, and because the knee braces are attached to them, they tilt too. When this happens one of the knee braces in the arch will head upward, while the other goes downward, and thus they would tend to slide past each other if it were not for the dowels that bind them together. Perhaps the Medieval designers lacked the formulas, but they did not lack a clear understanding of the forces that affected their building.

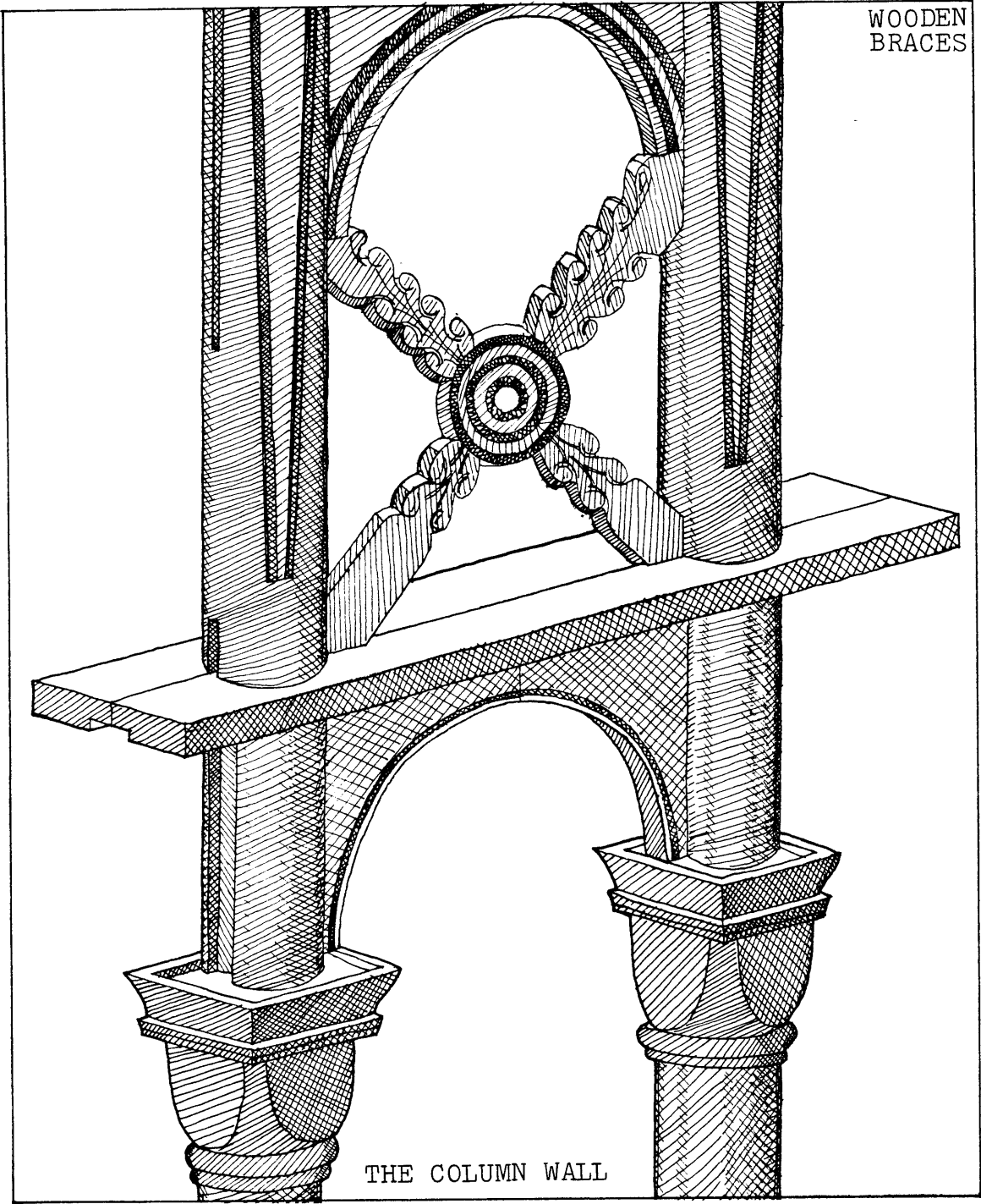

The braces are engineered to hold each other in place and to assist each other in the bearing of loads. Both of these functions are made possible by the tight joinery and the direct bearing of the braces against each other. But perhaps the most significant achievement of the column wall was its sculptural approach to structural engineering.

THE RAISING OF THE COLUMN WALLS

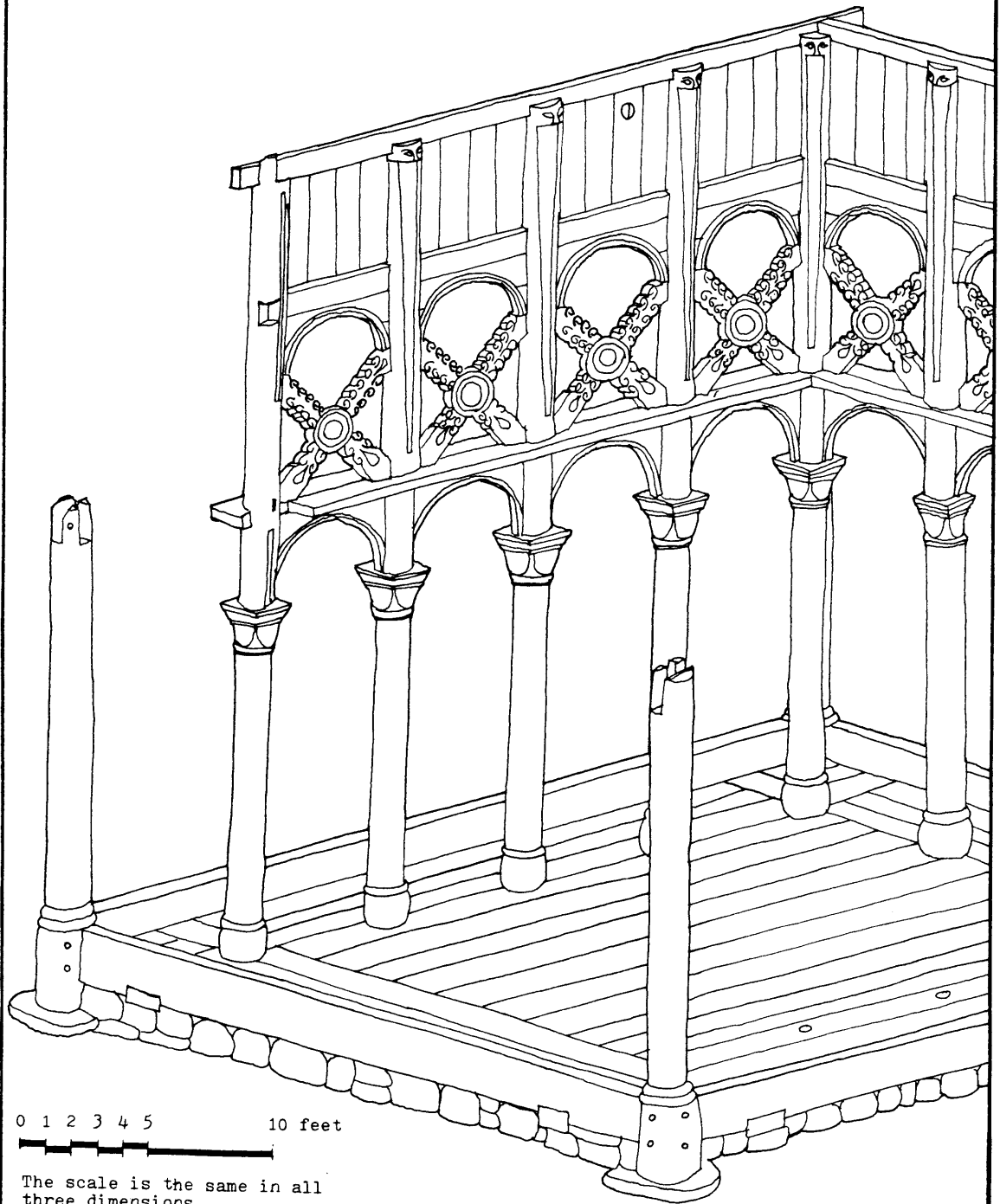

A second column wall is assembled on the ground, raised into position, and attached to the first column wall. The attaching of the column walls is performed in the air and entails connecting the wooden braces of the second column wall into the corner post of the first column wall.

THE THREE-DIMENSIONAL CHASSIS

The procedure of assembling the column walls on the ground and lifting them up and into position is continued until all four walls are fastened together. These four walls are the building's main structural support and form a kind of three-dimensional chassis. Other structural elements such as the aisle roof and the trusses are attached to the chassis. Structurally the chassis is analogous to a card table in that both are braced at the top and not the bottom. Such a bracing system works satisfactorily in resisting lateral forces as long as three conditions are met: (a) the columns must be large enough in diameter to resist the wind loads in bending, (b) the base of the columns must be prevented from sliding by at least a pin connection, (c) the building must be heavy enough to prevent it from overturning in a wind. The fact that the building is still standing after so many centuries is proof that the designers met the specific conditions imposed by elevated bracing.

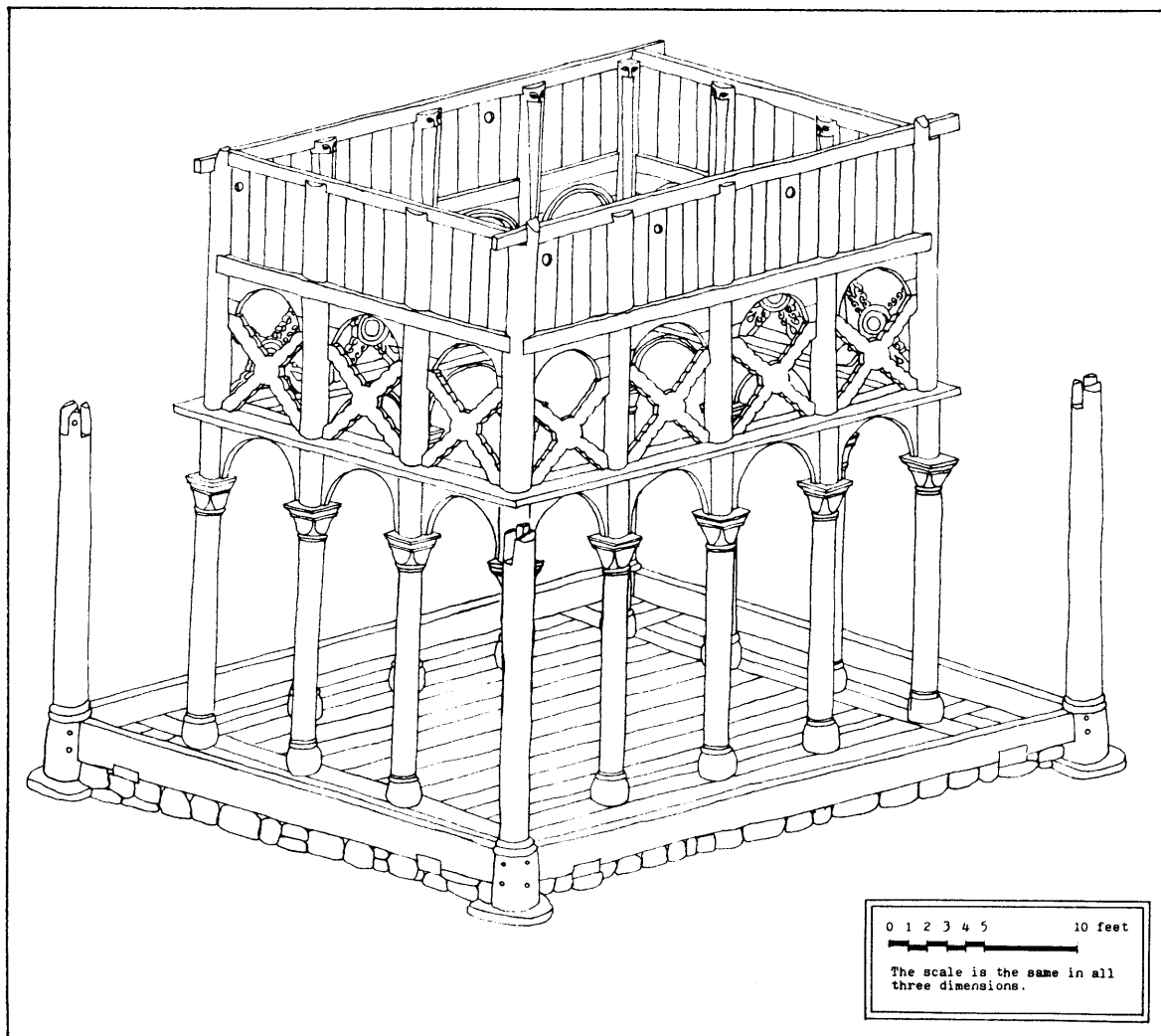

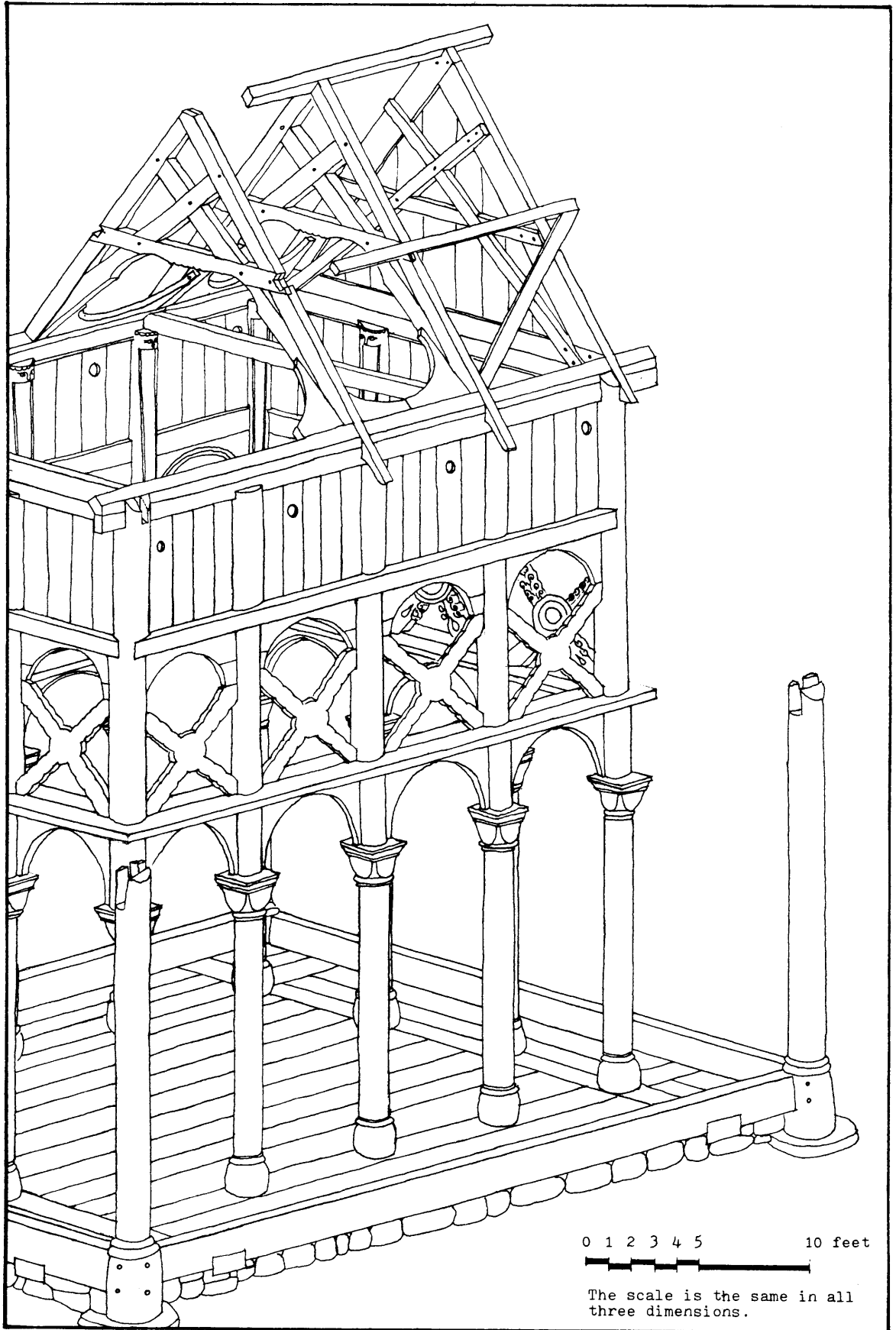

The trussed rafters of the Norwegian stave church are a forerunner of the modern scissor truss. The lateral beam of the truss contributes greatly to the strength and stiffness of the truss.

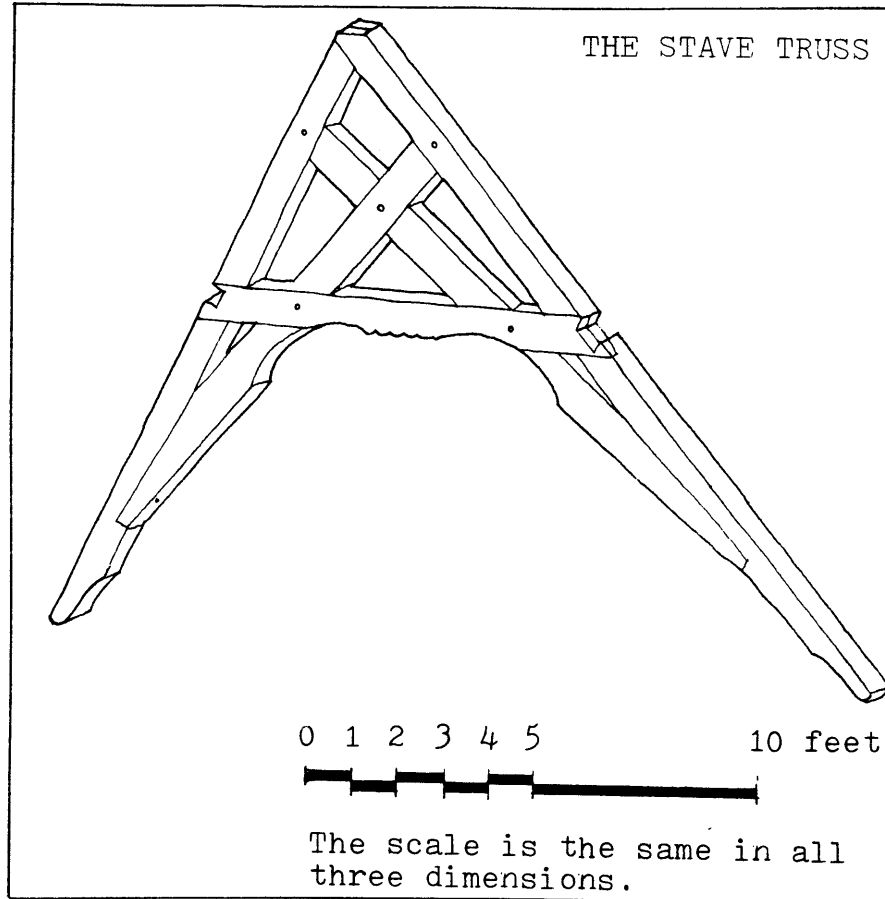

Perhaps partly because it allowed an open view of the ceiling, and partly because it gave an impression of a vault, the scissor truss gained wide acceptance in stave architecture. Employed in almost all of the remaining stave churches, the trussed rafter undergoes only slight variations from church to church, and even these changes are mostly stylistic. From a practical standpoint the steep pitch of the truss has been helpful in preventing large build-ups of snow which the comparatively weak scissor truss may not be capable withstanding. Roar Hauglid, the noted Norwegian historian of stave churches, believes that the truss was imported from abroad, probably France or England.

As with the column wall, the trusses were built on the ground and then lifted into position. The trusses support a ridge beam at the peak and a recessed purlin on each side. All connections are reinforced with wooden nails. The knee brace is used to make a rigid connection between the wall plate and the truss.

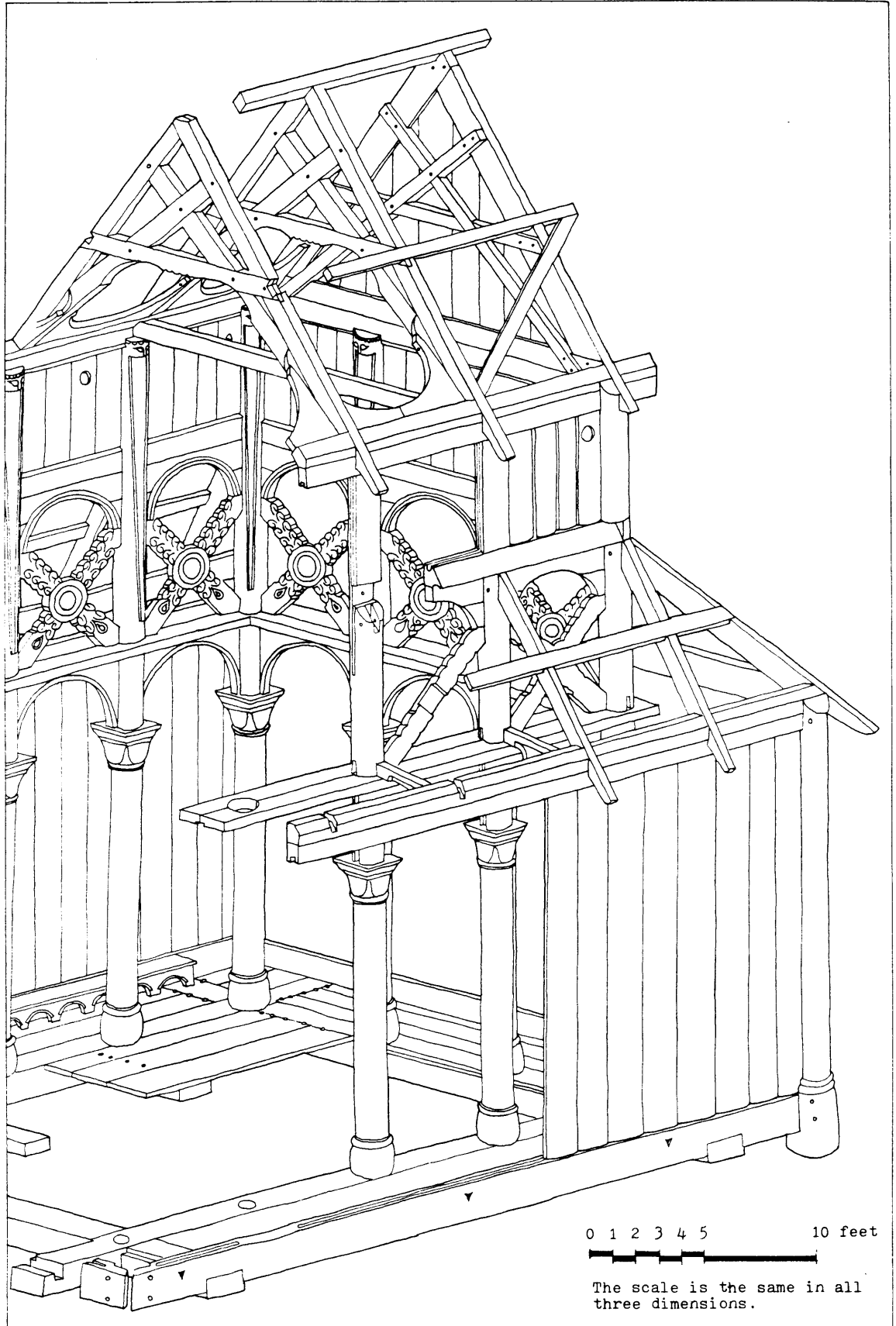

THE STAVE WALL AND THE AISLE ROOF

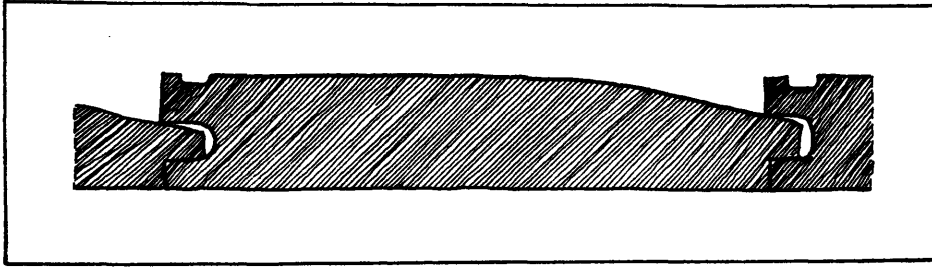

The cross-section on the top is one-fifth actual actual size. The ship lap joint used to connect the staves is carried out with such precision that it is hard to believe no machine tools were used.

One of the last stages of construction is the building of the wall which encloses the lower portion of the church. The wall is made up of staves which connect to each other by means of a tongue and groove. A similar connection is used to fasten the staves into the corner posts. Tenons at both ends of the staves fit into grooves in the sill (below) and the wall plate (above). The stave wall is held erect by diagonal struts which span over the aisle and attach into the free-standing posts. These diagonal struts are reinforced by knee braces and carry the weight of the aisle roof. The aisle roof wraps around all four sides of the structure and provides the free-standing columns with additional (perhaps redundant) lateral support. One of the important principles exhibited in this kind of stave construction is the separation of the primary structural elements from the weather membrane. This separation increases the life span of the building by protecting the main supports from the effects of the harsh climate.

The drawing on the left shows the construction of the exterior stave walls and the aisle roofs. On the inside an arcaded bench lines three of the four aisle walls. This continuous bench, which is interrupted only by the two doorways and the east wall, is the church's only seating. It is supposed that during services in the Middle Ages only the infirm and the aged were allowed to sit down.

THE STAVE WALL

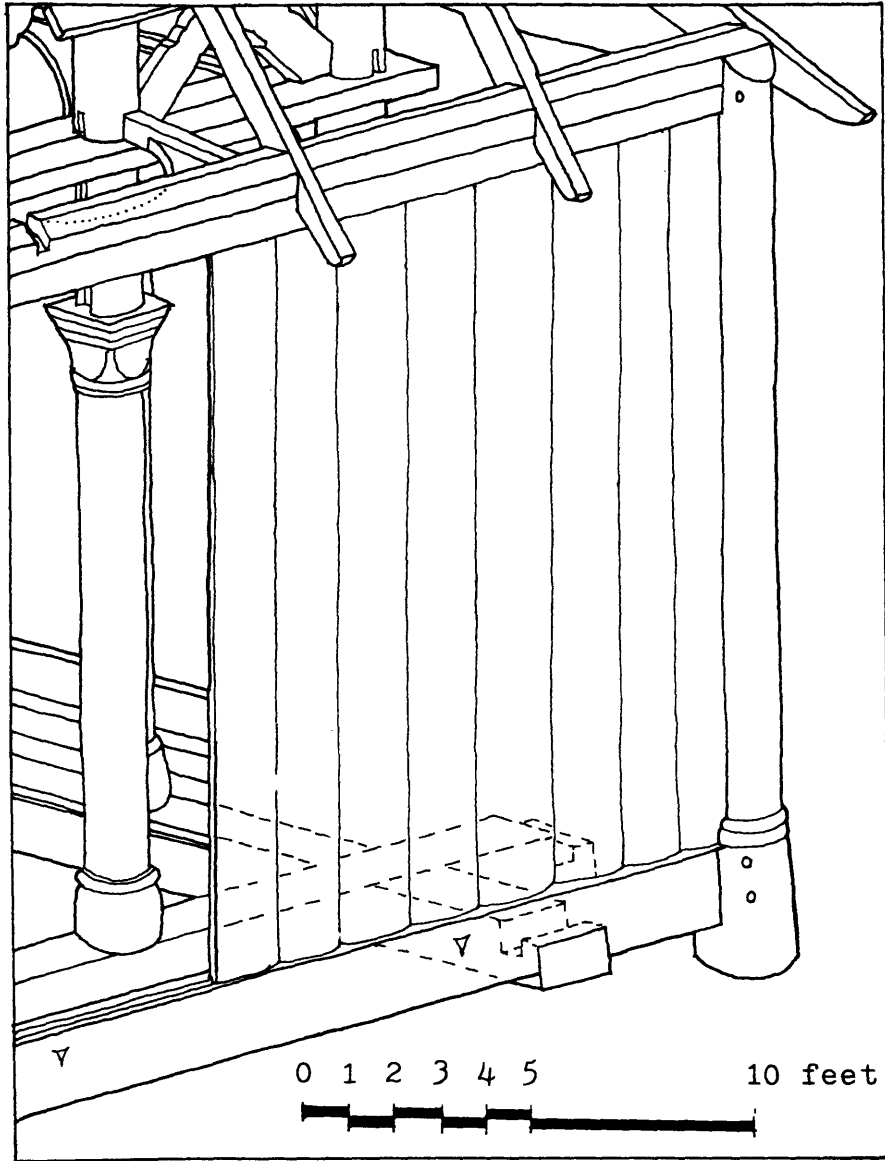

The technique employed in the building of the exterior wall accounts for the name "stave" construction. The stave wall can be understood as a wooden framework filled in by vertical planks, called staves. In this illustration of the Torpo Stave Church, the framework is composed of a sill, two corner posts (only one is shown) and a top plate. The staves have tenons carved on both ends and these fit into grooves cut into the top of the sill and the bottom of the wall plate. The staves connect to each other and to the corner posts with a tongue and groove joint. The expertise with which the joinery is executed enables the wall to act structurally, carrying a limited amount of the wind load into the foundation. The tight joinery also keeps out the cold winter weather.

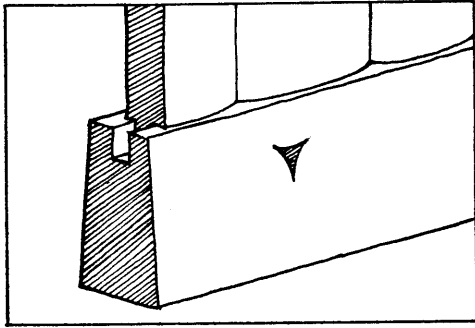

THE STAVE WALL AND THE DRAINAGE HOLE

Rain water, which can collect in the mortise, is led back outside through a "V" shaped hole cut in the side of the sill.

A small but significant example of how the Norwegian designers sought to perfect and preserve their work can be seen in their solution to a problem that arose at the base of the outside walls. The groove in the top of the sill caused a problem in wet weather because it collected the rain water that ran down the walls. With the groove acting like a water trough, both the sills and the bottom ends of the wall planks remained wet for long periods of time, leaving them susceptible to rot. If left unattended the rotting would collapse the walls, and this in turn would leave the interior unprotected.

Rather than abandon the vertical method of construction that seemed to be causing the problem, they opted to modify the existing design. They carved a series of small holes in the sill from the outside slightly below the bottom of the groove. The "V" shaped holes penetrated into the groove and served as miniature drains which prevented the rain water from collecting in the sill. The holes also allow air to circulate in the joint thereby evaporating any excess moisture that might have built up during a rain. As witnessed by the absence of rot in these joints today, a potentially serious problem was resolved in a simple yet effective way.

THE EXTERIOR

So far we have examined the nave and aisles of the Torpo Stave Church in order to understand the basic principles of stave engineering and joinery. However, Torpo is not a good representative of the fully articulated stave church because its chancel and apse were demolished late in the last century. In order to see how the Norwegian designers treated the exterior of their buildings, we will look at the Borgund Stave Church, one of the oldest wooden buildings intact in the world. The exterior remains almost unaltered since the Middle Ages. Included in the following pages are a series of drawings of the exterior of Borgund, and these are intended to be read in conjunction with the text.

It is important to recognize that the present exterior is not the original one. The shingles, which from a distance look like serpents' scales, did not cover the building when it was built in about 1150. Originally the sloping roofs were covered by wide planks laid horizontally; and the walls were sheathed with planks standing vertically. A black tar coating was applied over the planks to prevent wind and rain from finding their way inside the building. Either to give a new look to the building, or to achieve a more perfect seal against the elements, or both, the tarred planks were at a later date covered with hand-carved shingles. Historians believe this change occurred about one-hundred years after the church was built (about the year 1250). As with the planks, the shingles have been coated with the traditional tar compound, a process that has contributed greatly to the longevity of the building.

The drawing on the right is an elevation of the west side of the Borgund Church. Tarred planks, not shingles, were the building's original covering.

0 1' 2' 3' 4' 5' 10' 15'

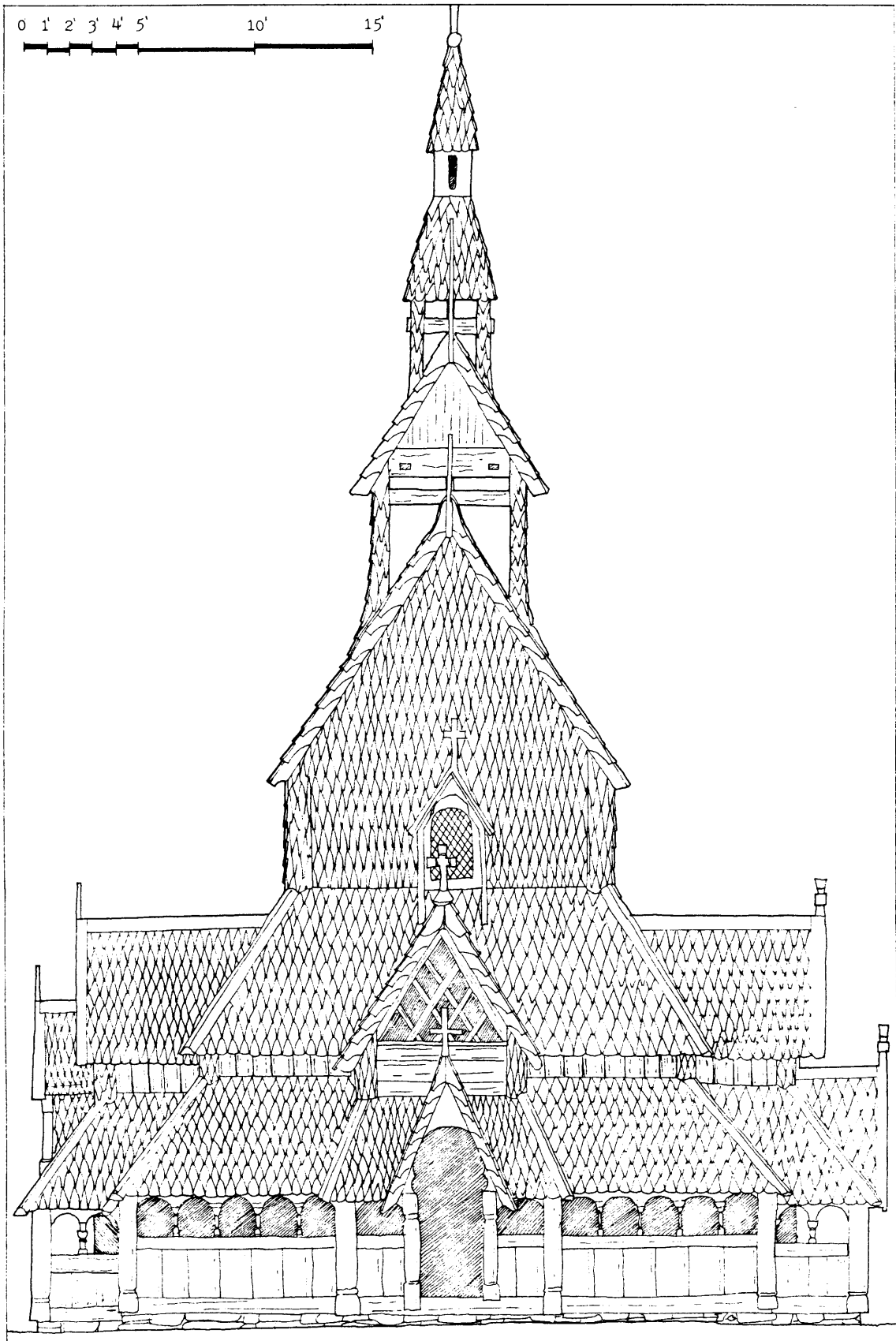

THE EXTERIOR

During the warm summer months when the sun beats down on the coated shingles, the black tar heats up and softens. Over a period of years some of the tar coating enters the pores of the wood making the surface of the wood virtually waterproof. As the tar wears off, it leaves the wood with a range of pleasing brown and red hues. This color change is most apparent on the south side of the building where the sunlight is the strongest. Conversely, the north side of the building tends to remain the cold black color of the tar compound. The striking difference in color from side to side is a reliable clue for fixing the orientation of the building.

In order to maintain the moisture barrier a new coating of tar is applied to the exterior about every four years. This process, which is still carried out to this day, has been kept up since the Middle Ages. Incidentally, the Vikings used a similar tar compound to waterproof their wooden ships. One important difference was that the Vikings added horse hair to their tar mixture.

One of the significant architectural achievements of the stave church is its ability to be at once intimate and monumental. Part of the sense of intimacy the building gives is due to its size; the Borgund Church is only fifty-two feet long. Achieving a monumental effect in a small building is a difficult architectural problem, and in the case of the stave church it was accomplished in part by cascading the roofs. The quick ascent of the stepped roofs

The elevation on the opposite page is of the western portion of the south facade of the Borgund Church. Notice how the pagan dragons occupy a higher position than the Christian crosses. Perhaps this is an indicator of the relative importance of the two religions. In other stave churches, for example, Heddal, the relative positions are reversed. Incidentally, Heddal was built after Borgund, at a time when Christian missionaries were having a stronger influence on the Norwegian population.

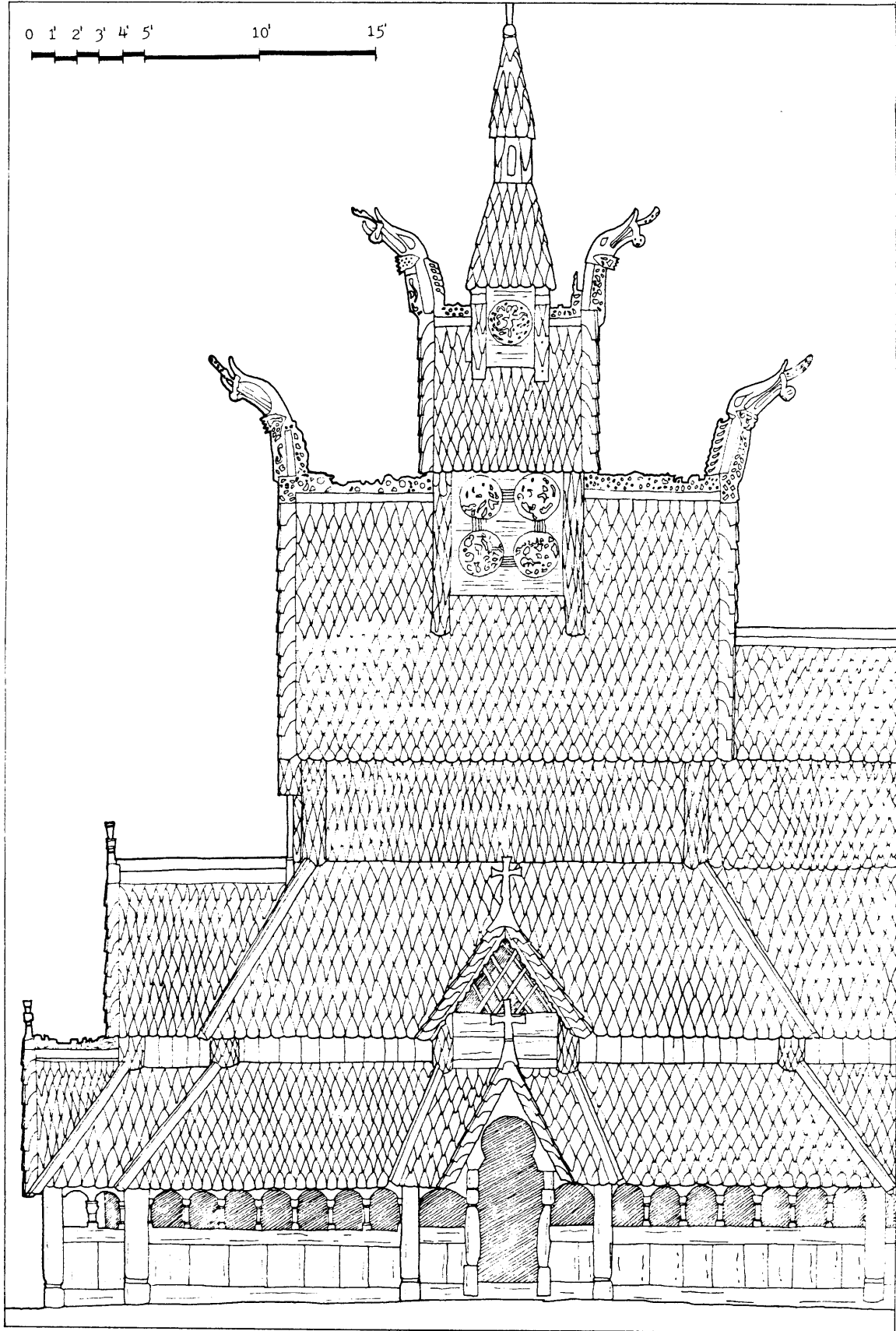

THE EXTERIOR

draws the eye upwards, and this effect is not unlike that of the spectacular vertical landscapes in Norway.

Though at first glance the stave church may appear to be an unintelligible collage of roofs, there is a hierarchy to the arrangement. In keeping with traditional church architecture the largest roof covers the nave. This perception can be confirmed by observing the bulge in the clerestory corners directly below the nave roof. These bulges are a result of the free-standing corner columns being used to frame the clerestory walls. The columns have been shingled to protect them against the weather. The fact that some of the primary structure makes it through to the outside is an exception to the general rule of separating the main structural members from the weather membrane.

The small round holes in the nave's clerestory are called apertures rather than windows because no glazing was used. These apertures are the only fenestration in the church and are the only source of natural daylight in the building. Candlelight was used to supplement the low level of natural light, and the candlelight in the dark nave must have given the room a very theatrical feeling.

There is a group of architectural historians that have viewed the stave church as an inverted Viking ship. Proponents of this view argue that the round apertures are analogous to the oar lock holes of the ships. Opponents of this view argue that the resemblance is purely coincidental.

The roof that is below and to the right of the nave's roof covers the chancel. This room houses the altar and the baptismal font. The roof directly below the nave's roof encloses the aisles. Like the pagan basilica of Rome, the aisle roof wraps around all four sides of the nave. Of all the roofs, the aisle roof plays the most important

The elevation on the right is of the back half of the Borgund Stave Church as seen from the south side.

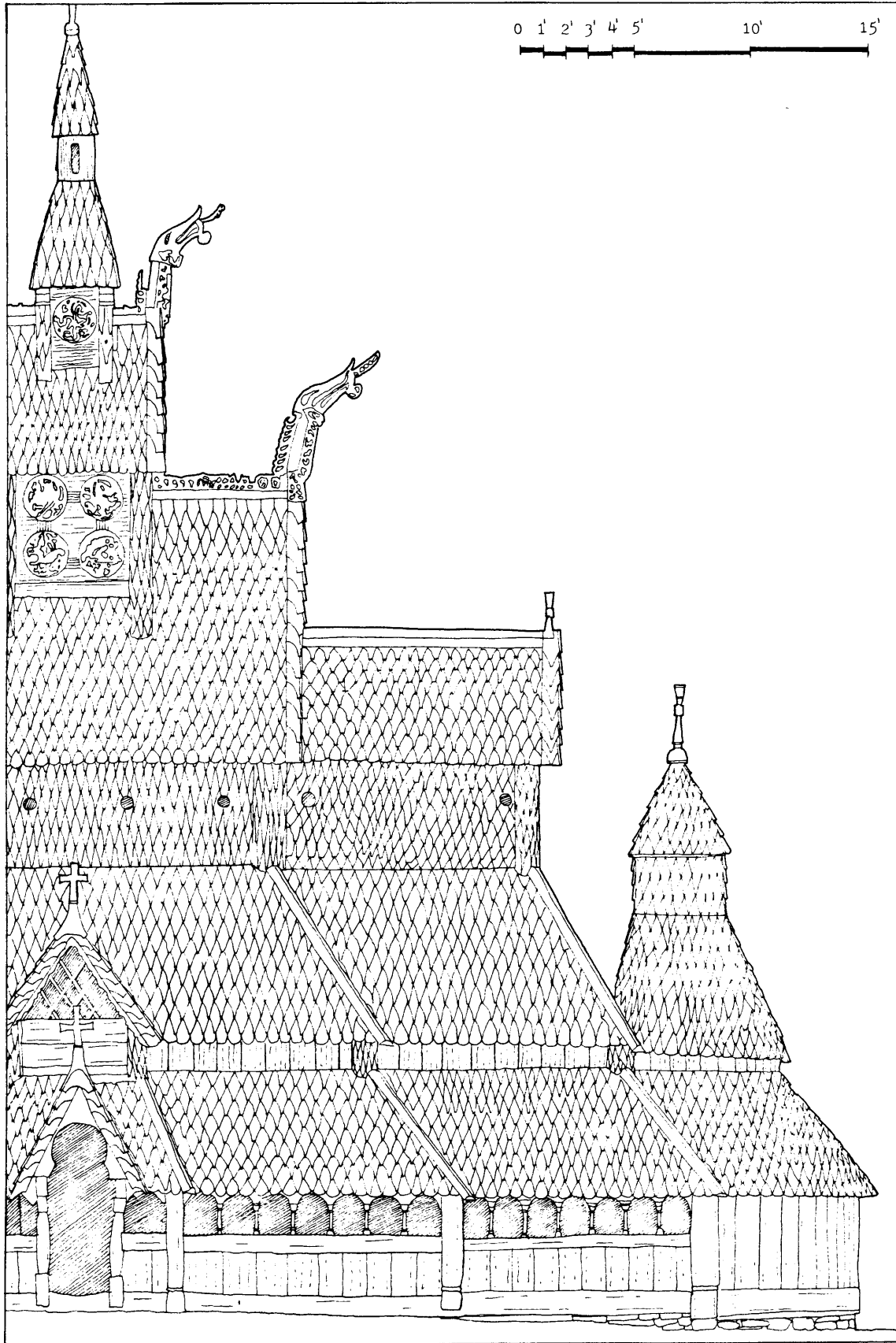

THE EXTERIOR

structural role. Because the aisle roofs wrap around all four sides of the nave, they are in a position to brace the elevated free-standing columns both laterally and longitudinally.

The lowest roof covers the ambulatory, a passageway that encircles most of the building. A window-sized arcade keeps the ambulatory open to the exterior. The ambulatory was as close to the service as some Norwegians were allowed to go. During the Middle Ages a high percentage of the Norwegian population suffered from leprosy, and because it was believed that lepers were inhabited by the devil, they were not allowed to attend with the rest of the congregation. The lepers, however, were allowed into the ambulatory, and from there they were permitted to view the service from small holes cut in the stave wall. Runic inscriptions carved on the church indicate that the ambulatory on the west side (called the porch) almost certainly was used as a marketplace. One of the runic inscriptions describes the exchange of farm animals. Since the church brought together citizens from the surrounding countryside, it is not unreasonable to assume that they used the occasion for both religious and economic benefit.

At the east end of the building is the semi-circular apse crowned by its conical turret. The apse is almost certainly a translation from "stone" architecture into wood architecture. There are two reasons for this conclusion. The first is that the semi-circular apse is a very difficult and awkward construction for stave technology because of the semi-circular sill. In standard stave construction the sill is a large straight member cut from a wide tree

The drawing on the right shows the east facade of the Borgund Stave Church.

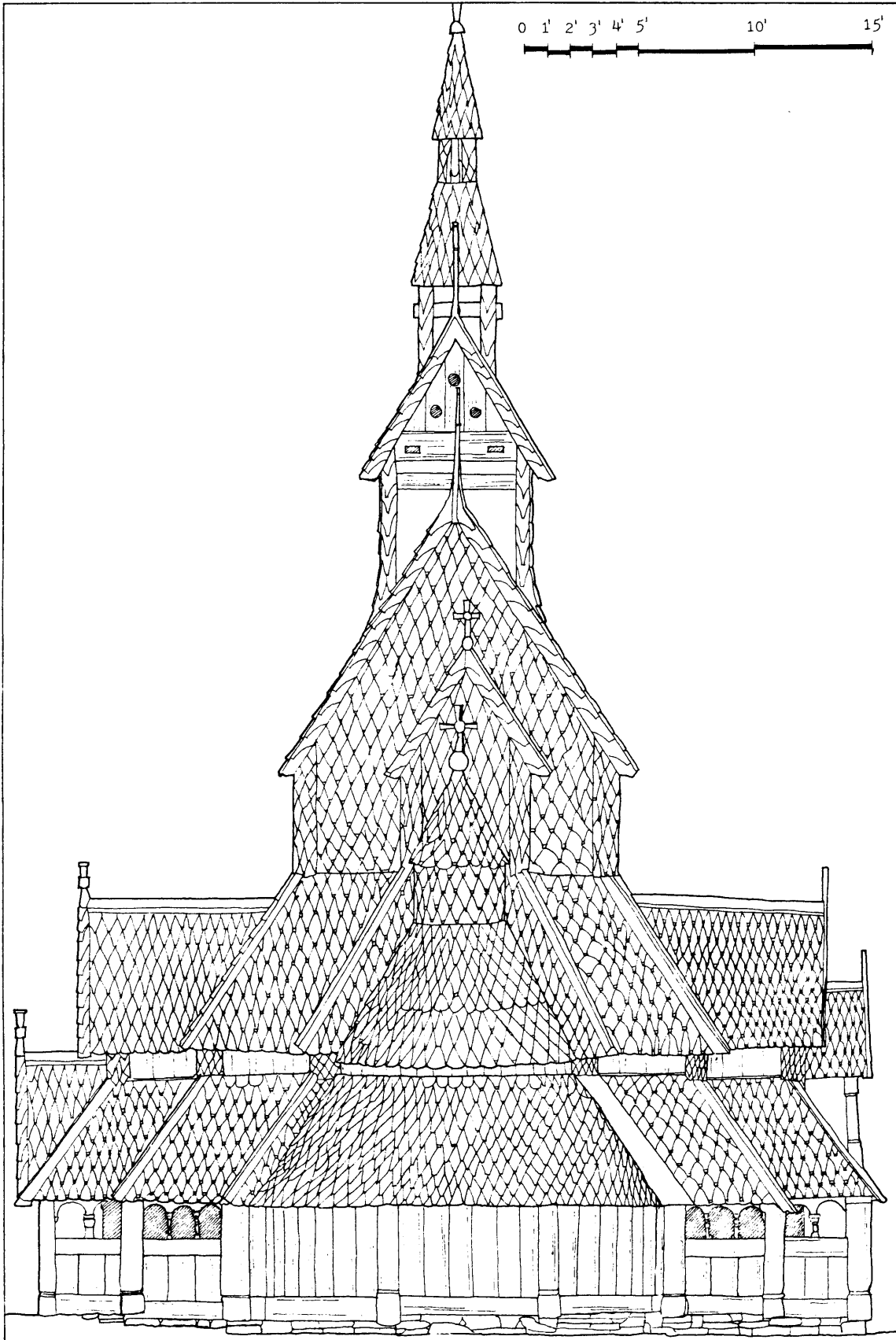

THE EXTERIOR

trunk. In the case of the apse sill, it is impossible to find a large tree trunk that is naturally curved into a semi-circle. Thus, in order to form a circular sill, it was necessary for the carpenters to splice together a number of partially curved members. The semi-circular apse is much easier to construct from unit masonry, and for these two reasons stave church historians agree that the apse probably originated in stone architecture and was subsequently incorporated into the stave church. Despite its origin in stone, the apse is a popular feature and gives the church some of its fairytale appearance.

Other than supporting the wooden spire, the two upper roofs serve only a decorative function. The roof below the the spire sits like a saddle on the nave roof. Suspended behind its elaborately carved clerestory are two bells. The carving, which is divided into four circles, depicts a dragon, whose head faces west. At both ends of the gable of this story are two more dragons, and below them are two more perched on the ends of the nave roof. Even though they differ stylistically from the dragons employed on the prows of the Viking ships, the stave dragons retain the same commanding presence.

Access to the Borgund Church is through either of the double gabled entrances. The main entrance is on the west side. According to some accounts, men entered the church through the west doorway, and women entered by the side door. The upper gable of both entrances houses a lattice screen. Recessed in from the edge of the building, the door hangs on the wall between the ambulatory and the aisle. The complex carving of the wood encasing the west door depicts serpent-like dragons engaged in mortal combat. The masterly composition is the work of a highly developed mind of pagan origin, and unfortunately the symbolic meaning of the piece eludes the modern mind.

THE EXTERIOR

The stepped roofs of the stave church have reminded many observers of pagodas from the Far East. This perception is reinforced by the dragons that surmount the roofs, because East Asian architects also built dragons on the peaks of their roofs. No concrete evidence exists which definitively links stave to East Asian architecture. The stave dragon is undoubtedly inherited from the Vikings. However, there may have been an architectural influence from East Asia on stave design via the Vikings. It is known that the Vikings travelled to Baghdad and Constantinople, and there traded for goods that originated in the Far East. In one Viking find, excavators unearthed a bucket, and on the side is a picture of a man sitting in a lotus position. In another Viking excavation, silk was found. These pieces of evidence strongly support the view that, either directly or indirectly, the Vikings were in contact with the culture of the Far East. Based on this it is possible to speculate that there was an influence on Viking culture from the Far East that was in turn handed down to the designers of the stave churches. Such an influence may be responsible for the pagoda character of the stepped roofs or for the dragon ornamentation on the roofs. On the other hand it is important to point out a crucial difference between the two kinds of structures. Unlike the stave church, pagodas were designed solely for external viewing, and it is clear that their designers never intended that they provide either shelter or useable space.

Photographs

This section of the thesis explores how the Norwegian designers enriched their buildings with carvings, paintings, and architectural detailing.



Door from the Garmo Stave Church



Doorway from the Torpo Stave Church



North Entrance to the Urnes Stave Church



Detail of the north door of the Urnes
Stave Church



Detail of animal ornamentation on a Viking ship





Carved capital from the Urnes Stave Church



Carved capital from the Urnes Stave Church



Painting on wood at the Torpo Stave Church



The martyrdom of St. Margaret, from the Torpo Stave Church



Carved head from the Hegge Stave Church



Head of Christ from the Urnes Stave Church



Columns and braces of the Torpo Church



Arcaded bench and column base from the Torpo Church



Stone foundation, sills, corner post, and staves of the
Torpo Stave Church

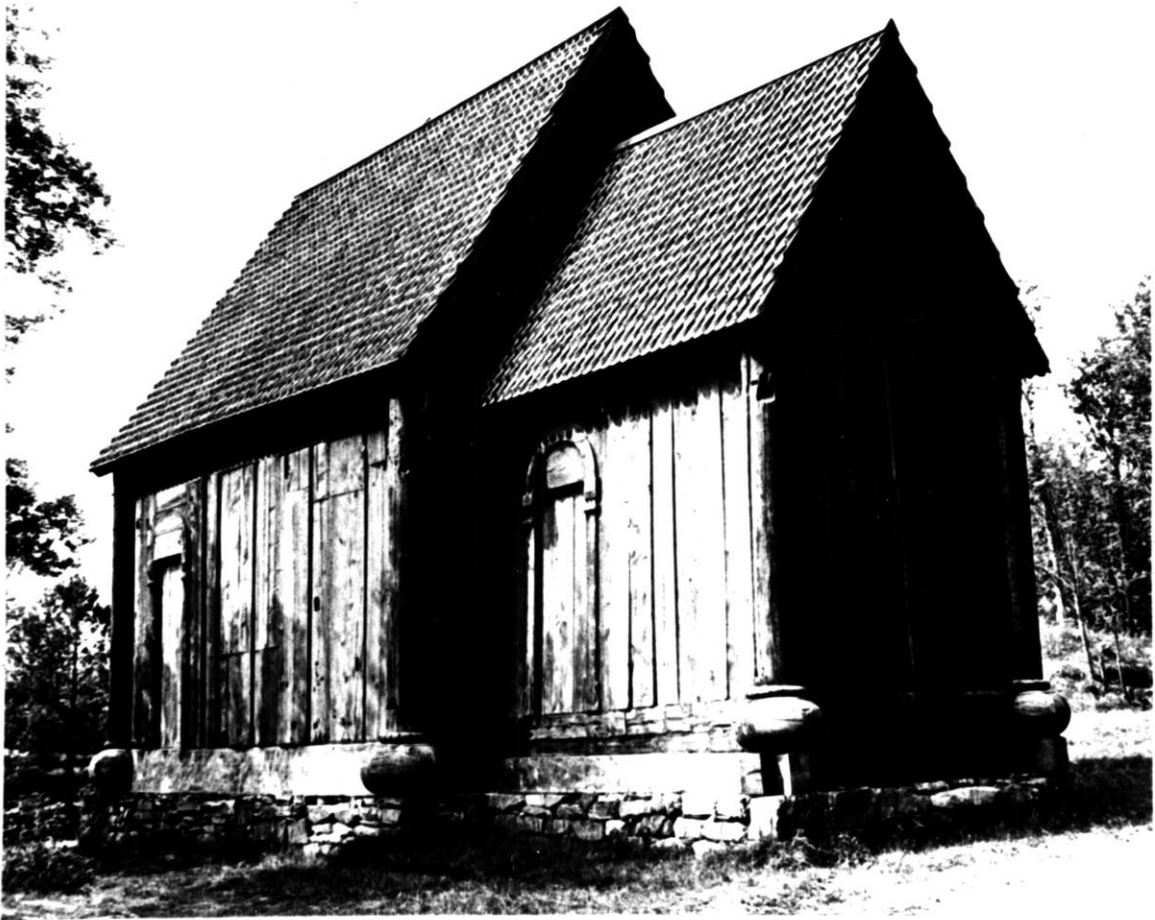

Nave and chancel of the Holtdalen Stave Church



Medieval Norwegian granary built in the stave style



Apse of the Heddal Stave Church



South side of the Heddal Stave Church



The Gol Stave Church



North side of the Borgund Stave Church

Concluding Notes

This work is an attempt to understand stave churches on their own terms, to show how in creating these wooden structures, the medieval designers took into consideration the properties of wood, the forces of nature, and the cultural and religious needs of their society. Having survived for almost a millenium, the stave church will be remembered in the history of architecture for helping to overcome the commonly held misconception that wood cannot be a long-lasting building material. They also testify to what architecture can achieve when designers work hand in hand with craftsmen and artists. One of the qualities that makes the stave churches so rich is that they exhibit a full range of architectural solutions -- from the detailing of wood connections to the creation of cultural symbols, and it is this last aspect of architecture in which the Norwegian designers excelled. Like the Viking ships, which condense into a single object what the Viking culture stood for, the stave church embraces the values of medieval Norway, and expresses the culture of the Dark Ages. The stave church can be read like a novel that brings to life an age that has long since past. In the stave church we can see expressed in wood, the intuitive understanding of the engineer, the technical proficiency of the carpenter, the design talents of the architect, and the artistic mastery of the painters and sculptors.

If my reader remains unconvinced that the stave church is a masterpiece of wooden architecture, I ask only that he or she let the stave churches speak for themselves, and that my skeptical reader travel to Norway to see the stave churches first hand.

In this work I have sought to emphasize the descriptive and to avoid the prescriptive. In keeping with this policy, I have decided not to use the conclusion as a platform on which to present a set of rules or guidelines for use in future architectural projects. This is not to say that there is not a great deal we can learn from the stave churches, or that they have little to contribute to our knowledge of wooden architecture, but rather that such prescriptive statements would be of dubious benefit and would probably only get in the way. My aim was to explain the background of the stave churches, and to show how they were designed and built, and to leave my reader free to pick and choose from the repertoire of architectural ideas. I hope that this work enriches the reader's understanding of wooden architecture; if my reader finds an idea or form that is applicable to his architectural practice, so much the better.

Footnotes

1. Kirkby, Hasloch Michael, The Vikings (Oxford and New York, 1977), pg. 111.

2. Kirkby, Hasloch Michael, *op. cit.*, pg. 115.

BIBLIOGRAPHY

- Alnaes, E., Eliassen, G., Lund, R., Pedersen, A., Platou, O., Norwegian Architecture Throughout The Ages, Oslo, 1950.
- Anker, Peter, Scandinavian Art, Volume I, London, 1969.
- Bjerknes, Kistian and Hans-Emil Liden, The Stave Churches At Kaupanger: The Present Church And Its Predecessors, Oslo, 1975.
- Blindheim, Martin, Norwegian Romanesque Decorative Sculpture 1090-1210, London, 1965.
- Blindheim, Martin, Stavkirkebyggernes Ristninger, Oslo, 1977.
- Boethius, G., Hallar, Tempel Och Stavkyrkor, Stockholm, 1931.
- Borgund Stavkirke, Foreningen til Norske Fortidsminnesmerkens Bevaring, Oslo.
- Braun, Hugh, An Introduction to English Mediaeval Architecture, London, 1951.
- Bugge, A., Norwegian Stave Churches, Translated by Ragnar Christapherson, Oslo, 1953.
- Crossley, Fred, Timber Buildings in England, London, 1951.
- Dietrichson, L., Die Holzbaukunst Norwegens, Dresden, 1893.
- Fett, H., Norges Kirker i Middeladleren, Kirstiania (Oslo), 1909.
- Hauglid, Roar, Native Art of Norway, Oslo, 1965.

BIBLIOGRAPHY

- Hauglid, Roar, Norse Stavkirker, Oslo, 1965.
- Hauglid, Roar, Norse Stavkirker, Oslo, Volume 1: 1973, Volume 2: 1976.
- Hauglid, Roar, "The Trussed-Rafter Construction of the Stave Churches of Norway," Acta Arch., Vol XLIII Kbh., 1972.
- Hopperstad Stavekirke, Foreningen til Norse Fortidsminnesmerkers Bevaring, Oslo.
- Horn, Walter and Born, E., The Barns of the Abbey of Beaulieu at its Granges of Great Coxwell & Beaulieu-St. Leonards, Berkeley, 1964.
- Horn, Walter, "Mediaeval Bay System," Mediaeval Architecture, Volume IV, New York, 1976.
- Kaupanger Stavkirke, Foreningen Til Norske Fortidsminnesmerkers Bevaring, Oslo.
- Kirkby, Michael Hasloch, The Vikings, New York, 1977.
- Krautheimer, Richard, Early Christian and Byzantine Architecture, Baltimore, 1969.
- Laver, H., "Greensted Church," Essex Arch., London, 1908.
- Liden, Hans-Emil, "From Pagan Sanctuary to Christian Church: The Excavation of Maere Church," Norwegian Arch. Review, Volume 2, Oslo, 1969.
- Lindholm, Dan, Stave Churches in Norway, London, 1969.
- Lundberg, Erik, Tra Gav Form, Stockholm, 1970.

BIBLIOGRAPHY

Moe, Ole Henrick, "Urnes and the British Isles: A study of Western Impulses in Nordic Styles of the 11th Century," Norwegian Arch. Review, Volume 2, Oslo, 1969.

Strzykowski, J., Early Church Art in Northern Europe, London, 1928, New York and London, 1929.

Strzykowski, J., "The Northern Stream of Art from Ireland to China and the Southern Movement," Yearbook of Oriental Art, Volume I, London, 1925.

Torpo Stavekirke, Foreningen til Norske Fortidsminnesmerkers Bevaring, Oslo.

Walsh, A., Scandinavian Relations with Ireland, London, 1922.

Wernick, Robert, The Vikings, Alexandria, Virginia, 1979.

