

Design of a Voice Coil Actuated Office Chair

by

Jeremy H. Scholz

SUBMITTED TO THE DEPARTMENT OF MECHANICAL ENGINEERING IN
PARTIAL FULFILLMENT OF THE REQUIREMENTS FOR THE DEGREE OF

BACHELOR OF SCIENCE IN MECHANICAL ENGINEERING
AT THE
MASSACHUSETTS INSTITUTE OF TECHNOLOGY

JUNE 2004

© 2004 Massachusetts Institute of Technology
All rights reserved

Signature of Author.....
Department of Mechanical Engineering
May 7, 2004

Certified by.....
Cynthia Breazeal
Assistant Professor of Media Arts and Sciences
Thesis Supervisor

Approved by.....
Woodie Flowers
Pappalardo Professor of Mechanical Engineering
Mechanical Engineering Faculty Reader

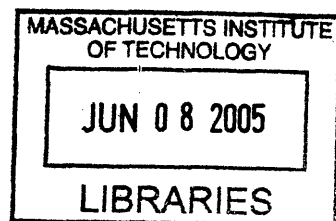

ARCHIVES

Design of a Voice Coil Actuated Office Chair

by

Jeremy H. Scholz

Submitted to the Department of Mechanical Engineering
on May 13, 2005 in Partial Fulfillment of the
Requirements for the Degree of Bachelor of Science in
Mechanical Engineering

ABSTRACT

In recent times, the use of robots in industry has revolutionized production methods, and enabled an increase in the quality of goods manufactured while decreasing the long term cost of labor. The commercial market, however, is largely lacking in robotic technology which could potentially revolutionize many everyday tasks undertaken by humans. This thesis describes a design integrating robotic technology with a common office chair. The requirements of such a chair are discussed, as well as the resulting design decisions. The advantages and drawbacks of the Voice Coil Actuators used in the design are also discussed. A prototype control system, enabling ergonomically beneficial motion is described and analyzed. Additionally, qualitative feedback from human testers is given, and suggestions for future work are made.

Thesis Supervisor: Cynthia Breazeal
Title: Assistant Professor of Media Arts and Sciences

Acknowledgements

First, I would like to thank Steelcase Inc. for the generous donation of advanced office chairs for this project, as well as for their support and advice.

Additionally, I would like to thank John McBean for his advice regarding Voice Coil Actuators, as well as for support in developing a control system.

I would like to thank Cynthia for coming up with this great idea and for providing creative input. Without your occasional prodding motivation to finish the project, I very well may not have.

Finally, I would like to thank Fred Cote for his invaluable advice regarding my often unusual machining projects. It has been a pleasure working in the Edgerton shop over the past four years; you will be missed after this year.

Table of Contents:

1.0 Introduction	5
1.1 Robotic Applications	5
1.2 Potential for Robotics in Ergonomics	5
1.3 Design Challenge	6
1.4 Group motivation	6
2.0 Background	7
2.1: Seating and back pain	7
2.2 Ergonomics and Robotic Applications	8
3.0 Chair Design:	9
3.1 Chair Choice	9
3.2 Actuator Choice	11
5.0 Results and Discussion:	24
5.1 Results.....	24
5.2 Discussion	24
6.0 Future Work and Conclusion:	25
6.1 Future Work	25
6.2 Conclusion	26
References:	27

1.0 Introduction

1.1 Robotic Applications

Recent advances in basic motion control technologies including actuators, sensors, and control systems have allowed robotic systems to become increasingly successful. Modern industrial robots perform many tasks far more efficiently and safely than unaided human workers. However, much of the true potential of robotic systems has yet to be realized. Currently, most robotic systems are developed explicitly for industrial applications, leaving the commercial market largely void of robotic technology. However, it has become clear in recent years that proper incorporation of robotic technologies into common goods can lead very successful products. This thesis investigates the application of robotic technology to ergonomic motion capabilities of a common office chair.

1.2 Potential for Robotics in Ergonomics

Recent studies have shown that low frequency movement of the spine in various axis can help reduce back pain and raise workplace productivity. Steelcase Inc. has developed an advanced office chair capable of passively enabling a seated user to change positions more easily than possible in traditional task chairs. The chair was designed to enable smooth transitions from one seated posture to another; however, even this advanced chair still relies on the user to seat properly in the chair and move on their own. Without proper ergonomic training, users can misuse the adjustments of the chair and avoid seating in the chair with proper posture, thus hindering the chair's ability to keep the user pain free.

With the addition of robotic actuators and sensors to two the chair's major ergonomic motions, the chair can be made to actively work towards the health of the user. These actuators perform two major functions: adjust the chair for each specific user, and actively change the position of the user. With the addition of automation to the

passive ergonomics of the chair, it is believed that short and long term health benefits can be realized, as well as increased productivity resulting from decreased discomfort.

1.3 Design Challenge

The design of such a robotic chair requires careful attention to the needs of its users. Unlike industrial robots, which can move as quickly and roughly as their frames will permit, a personal robot must at the very least avoid annoying its user with choppy or noisy motion. In short, a successful personal robot must avoid all stereotypical machine characteristics. In the case of the design presented in this thesis, the design aims to avoid notifying the user of any motion at all. By keeping all motion smooth, silent, and slow, the robotics of the chair aim to increase the health of the user without actually betraying to them that motion is occurring. This will allow the user to continue with their tasks without being distracted by either pain or automated motion.

1.4 Group motivation

This thesis is being sponsored by the Robotic Life group at MIT's Medialab. The group works on creating technology for human interaction with robots. The lab is currently developing a few human interaction robots including child sized furry being named Leo capable of imitating human facial expressions as well as understanding everyday language and completing simple tasks, and a stuffed animal capable of imitating a real pet. A robotic office chair fits in with the group's goals perfectly, being an extremely intimate and very interactive object. With this prototype, it is hoped that we will better connect robots to people, as well as help people live more comfortably.

2.0 Background

2.1: Seating and back pain

Prolonged seating in a constant position has long been accepted as a risk factor for lower back pain due to increased pressure on portions of the lumbar spine. During any prolonged static activity such as sitting, an excess of intradiscal pressure can cause the onset of lower back pain¹. Due to increased pressure for extended periods, a measurable shrinkage of the spinal discs occurs, placing strains on the surrounding tissues. Although the overall shrinkage rate is generally greater in standing than sitting, the prolonged periods during which people tend to sit in the modern world likely makes it a greater source of shrinkage and back pain than any other activity. In sitting, a number of common poor seating practices can lead to an even greater amount of spinal pressure for greater durations than necessary.

The first of these causes is a loss of lumbar lordosis, or the inward tilt of the lumbar area of the spine. Brought about by a variety of causes a loss of lordosis is an easily preventable condition which most chairs fail to address, by providing inadequate lumbar support. Acceptable lordosis, visible in someone with “good posture”, can cause a decrease in the spinal pressure which can be problematic in extended seating. Slouching motivated by deskwork causes a reverse in the spinal curvature called kyphosis, resulting in the greatest increased strain of any seating posture.

The second addressable source of pressure while sitting is the fact that the activity is generally static. Given a periodically moving body, increased stress in the spine is at least shifted throughout the seating period, causing a decrease in spinal compression. In fact, some studies have shown that motivated spinal motion while seating can actually reverse the normal shrinkage seen in prolonged seating.² Although more difficult to

¹ L.L. van Deursen, D.L. van Deursen, C.J. Snijders and H.J. Wilke, Relationship between everyday activities and spinal shrinkage, *Clinical Biomechanics*, Volume 20, Issue 5, June 2005, Pages 547-550. (<http://www.sciencedirect.com/science/article/B6T59-4FKYF01-3/2/80f00b467a378a2b946896f57b975048>)

² D. L. van Deursen, M. Lengsfeld, C. J. Snijders, J. J. M. Evers and R. H. M. Goossens, Mechanical effects of continuous passive motion on the

address in a chair design than lordic pressure, it is still possible to at least allow, or better to motivate periodic motion during seating.

2.2 Ergonomics and Robotic Applications

Most chairs fail to properly discourage postures which lead to excessive pressure, and fail to allow for movement by allowing only one comfortable seating position. This combined with the increase in deskwork done by most Americans in the past half century means that sitting has become a significant source of discomfort among the working public. Fortunately, some chairs have now been designed with ergonomic principals in mind seeking to eliminate bad posture, support the lower back, and/or allow motion.

Chairs with lumbar support, and adjustable or fluidly movable components have become much more common. One such chair, the Leap™ by Steelcase, was proven to decrease discomfort among desk workers.³ Furthermore, those with the chair and training were also proven to be more productive than their counterparts with standard chairs by as much as 18%. This increase in productivity is extremely important for the field of ergonomics, as it economically validates further research into seated ergonomics. Productivity gains that high are difficult to achieve by any means, let alone a simple piece of office furniture.

However, there are still a number of issues to be tackled in the field of ergonomics. A person must be trained to use the chair properly, both in the adjustments as well in the proper postures to get the most of the chair's features. Any bad habits will also likely remain unless the chair user makes a conscious effort to eradicate them. In addition, even if the Leap™ chair is easy to switch positions in, it relies on the user to do so consciously. It is with the issues that an intelligent, active chair may have an advantage. A robotic chair could adjust itself for the user, and motivate the user to change positions, either consciously or unconsciously, whether by jiggling a user out of a slouch

lumbar spine in seating, *Journal of Biomechanics*, Volume 33, Issue 6, June 2000, Pages 695-699.
(<http://www.sciencedirect.com/science/article/B6T82-408JKS4-7/2/88bafc5b3b436b39bda46f9a54eaca1e>)

³ <http://www.steelcase.com/Files/4b7a79f0f6d1411b8e3b24eccf57cc07.pdf>

or gently changing the angle of their hips over the course of a few minutes. Potentially, the proper chair could turn the static activity of sitting into a much more active and healthy action, in addition to providing occasional entertainment if the user so desired.

3.0 Chair Design:

3.1 Chair Choice

The chair utilized as a test base for this project was the Leap™ chair by Steelcase. The chair was generously donated by Steelcase Inc. for use in this project. The Leap™ chair was originally designed to enable adjustment to a variety of human body sizes, as well as enable easy transitions between various sitting postures. From an ergonomic standpoint, it is probably the most advanced chair available today. The capability for smooth movement inherent in its design made it an ideal chair for transformation to an active ergonomic robot. Two motions of the chair were to be fully automated: the seat position and the lumbar support. As these two movements determine the amount of lumbar lordosis, it is believed that placing them in constant motion can help relieve the excess stress created in the back during sitting. Figure 1 shows an image of the Leap™ chair.



Figure 1: The Leap™ Chair by Steelcase, viewed from back.

In the design of this chair, care must be made to ensure that the object feels as organic as possible. The potential of the chair to increase productivity and happiness will be drastically limited if the chair user is reminded of heavy machinery each time an automatic adjustment is made. Thus silent and smooth actuation of all motions must be accomplished. Further, all joints must be made as smooth and silent as possible. Any actuators which act directly on the body must also be back-drivable, as firmly driven actuator acting on the body could be both uncomfortable and dangerous. Since this is a very intimate robot design, the design must emphasize the comfort of the user.

3.2 Actuator Choice

The actuators chosen for use in the chair are voice coil actuators, or VCA's. A Voice Coil Actuator generally consists of one or more sets of coiled wire placed in a permanent magnetic field. Either the field or the coil is held stationary, and referred to as the stator, while the moving part is called the rotor. Both moving magnet and moving coil designs are possible. Any current applied to the coil results in a force of

$$F = n\pi diB\sin\theta, \quad \text{Eq. 1}$$

where n is the number of coils, d is the average diameter of the coil, B is the strength of the magnetic field, and θ is the angle between the magnetic field and the coil. This means that the actuators have a theoretically flat output force curve over position and speed, making them easy to control via feedback control systems. Voice coils are typically used as the drive mechanism for audio speakers, as well as the drivers for the read heads in CD drives, but are occasionally used to drive larger loads, such as in the Bose® ELectroForce® materials testing station.

Voice coil actuators are ideal for the implementation of tactile human interaction robots due to their back-drivability, high power density, and silent operation. From the standpoint of feel, the motion produced by VCA's is quite similar to what is produced by vertebrate muscle. Further, their back-drivability makes them much safer than most other linear motion sources. Instead of maintaining a position, as gearmotor and hydraulic actuators do, VCA's maintain only a force, which can be easily limited within the control system to levels safe for human interaction.

Voice Coil Actuators do have a few problematic characteristics when compared to other types of actuators. Although efficient at high speeds, the efficiency of an actuator drops to near zero at low speeds. The efficiency of a voice coil is defined as a ratio of the output kinetic energy to the input electrical energy, or

$$\varepsilon = \frac{F \cdot V}{v \cdot i} \quad \text{Eq. 2}$$

where F is the output force, V speed of the rotor, v is the input voltage, and i is the input current. Hence as V drops to zero, so does the efficiency of the actuator. There is also the problem of unnecessary wasted resistance in the coils which do not see much magnetic field. As most VCA's are not commutated, meaning that all coils are active simultaneously, there is a vast difference between the magnetic flux seen at different points along the length of the coil. For this reason, actuators of high strain become much less efficient than low strain actuators. Improvements to voice coils which would raise the efficiency could include commutation of the coils, and increasing the strength of the flux seen by the coils by decreasing the reluctance of the flux path, however these improvements are beyond the scope of this thesis.

3.3 Actuator Design

The design for actuators used in this thesis was first conceived by John McBean, and detailed in his M.S. thesis⁴. The actuators have been optimized for ease of production as prototypes. The actuators consist of a stationary coil restrained by an outer shell of electromagnetic tubing and an inner shell of thin walled aluminum, within the inner shell lays the moving magnet assembly. The magnets are axially magnetized NeFeB magnets, and are retained by a thin walled aluminum shell. The moving magnet design is used to avoid the complexity of getting power to a moving interior coil. On either end of the rotor assembly is a hardened steel shaft pressed into holders adjacent the magnets on either end. Each shaft is supported by a ceramic coated linear bushing retained in either end cap of the assembly. The two coils are independently wound of 18 gauge magnet wire. The ratio of lengths of the two coils and the rotor are set so that each end of the rotor will stay

⁴ John M. McBean, *Design and Control of a Voice Coil Actuated Robot Arm for Human-Robot Interaction*, © 2004 Massachusetts Institute of Technology

within its respective coil throughout the throw of the actuator. The figure below depicts solid models of the two actuators.

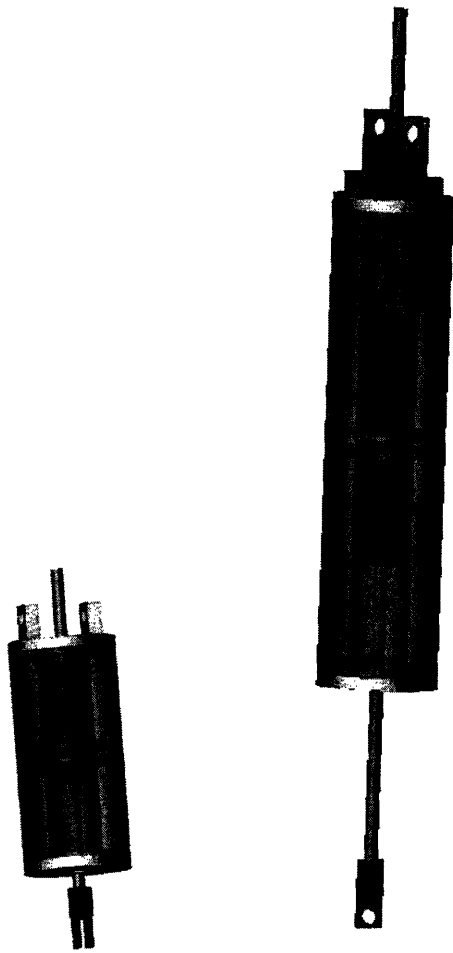

Figure 2: The Lumbar (small) and Seat (large) actuators

Each actuator reaches a static force of roughly 20lbs at 100W. This was deemed sufficient for the movement of a seated user though various positions. The stroke lengths of the two actuators are 2in. for the smaller actuator, and 4in. for the larger actuator. The longer throw actuator was developed for the seat movement, which has a maximum throw of 3.5 in. The smaller actuator was borrowed from a robotic arm for use in the

lumbar support which has a maximum stroke of roughly 1.5in. Although these actuators are inefficient at the slow speeds which are desired for the chair, their muscle-like characteristics make up for this shortcoming. Additionally, it is believed that any chair would be located nearby a power source, thus making steps toward lower power consumption unnecessary.

3.4 Chair Joint Design:

Conveniently, the lumbar support region of the Leap™ chair is already designed to move in a fluid manner, and thus could be integrated with the voice coil actuators easily. An actuator was mounted on the back so as to pull upward on the curving mechanism of the chair, forcing the mechanism to bulge outward thus increasing lordosis. The figure below shows an image of the mechanism in both states.



Figure 3: Lumbar support in outward (left) and inward (right) positions. Actuator displacement can be seen by the movement of the aluminum mount below the actuator body.

Unlike the lumbar support joint, the seat movement joint was only designed with occasional motion in mind, and thus required modification before it could be properly actuated. Seat movement in the original design was accomplished via the use of a linear bushing. Though the bushing was capable of handling the load of any reasonable chair user while still providing a low friction surface it left too much static friction in the joint to allow for smooth motion when driven by a voice coil. In place of this bushing a linear ball bearing assembly was used. Although a temporary bearing assembly of rotary ball bearings and aluminum tube is currently in place, a true recirculation ball bearing system is planned for the near future. As a result of this change the seat level was raised approximated 1". Although not ideal, as it changed the relative position of the seat and lumbar support, this alteration avoided any major modifications to the chair's structure, and allowed very smooth motion in the seat. A solid model of the seat joint before and after the modification can be found in the figures 4 and 5 below.

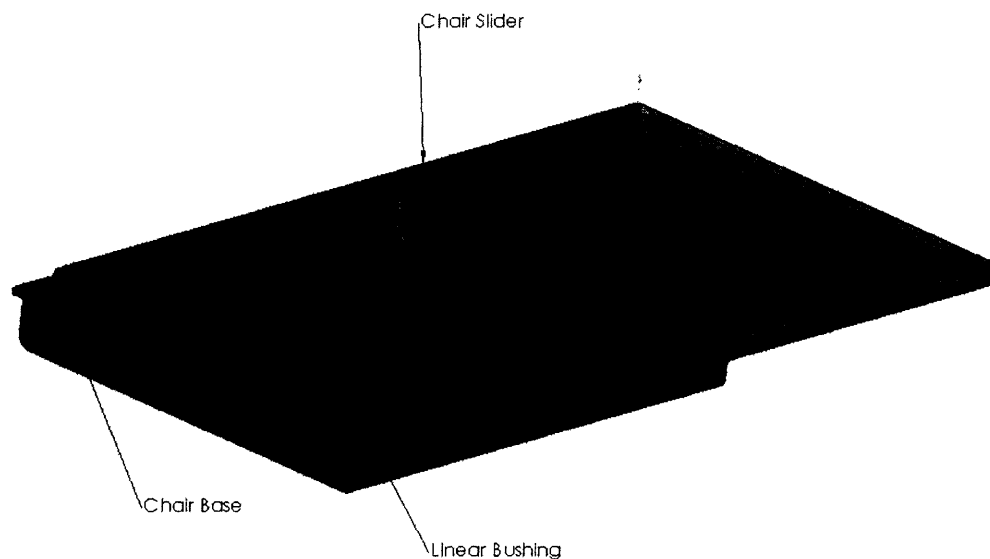

Figure 4: Chair bushing joint before modification. The Chair Slider is attached to the seat, while the Chair base is attached to the main frame of the chair .Torsional, Lateral, and Vertical support were all provided by a plastic linear bushing surface.

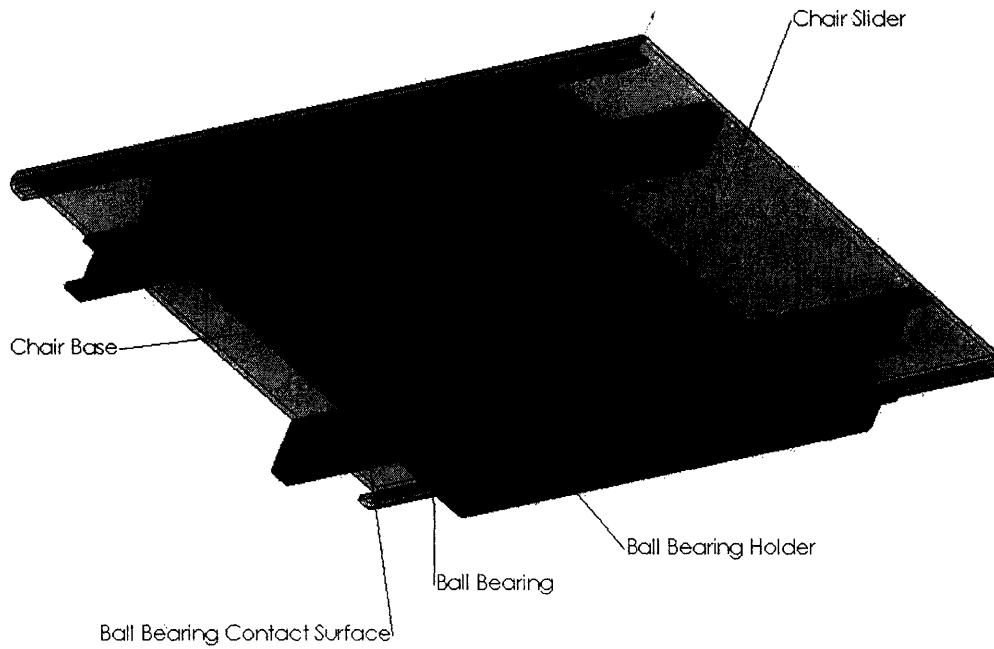

Figure 5: Chair Sliding mechanism with ball bearing supports. Two pieces of Aluminum C channel ride on 11/16" OD ball bearings. Lateral and torsional stiffness come from contact between bearings and C channel wall.

Figures 6 and 7 show pictures of the chair and actuators from various angles.



Figure 6: Chair from Back, showing lumbar and seat actuators.

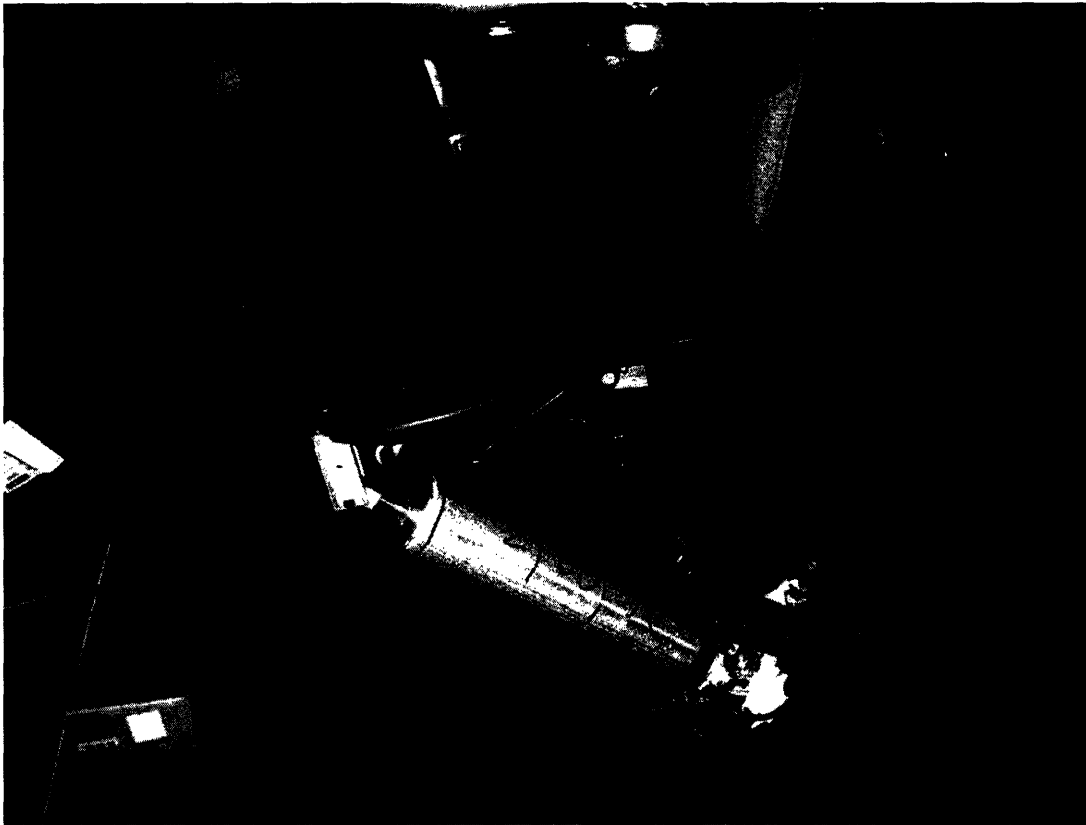

Figure 7: Chair From side angle, showing seat actuator.

4.0 Control System

4.1 Control System Hardware

The chair is controlled by an IMB workstation utilizing a dSPACE I/O board. Control systems for the two joints were written in Matlab's Simulink™ which interfaced with dSPACE control software and hardware. The dSPACE I/O board consists of 8 A to D inputs, and 8 D to A outputs, along with digital to digital inputs and outputs which were not used. Position information was read by one Compact Linear-Position Transducer from McMaster-Carr on each axis. The position transducers have a repeatability of .003" and a full range accuracy of .05" over a 10" extension length, making them more than accurate enough for sensing position in this application. The sensors are a wire pull type, making them easily mountable, and very inexpensive

compared to rod extension transducers. Maxon 4-Q-DC servo amplifiers driven by a set signal from the dSPACE board were used to power the two VCA's. Two 30Volt 2Amp amplifiers were used to power the lumbar support actuator, one for each of the two coils, while one 50Volt 10Amp amplifier was used to power the chair base actuator, with the two coils wired in series. Figure 8 shows an image of the dSPACE control box and servo amplifiers.



Figure 9: dSPACE control board and servo amplifiers.

Figure 10 shows an image of the wire pull position sensor mounted on the chair back.



Figure 10: Close up view of wire pull type position transducer.

4.2 Control System Software

Two different control algorithms were written for the two actuators, taking into account the different requirements of motion control for each axis. While the seat position should be position controlled, as it is less desirable for the seat to move about significantly due to the user shifting positions, the lumbar support should be force controlled and allowed to flex so long as the proper force is applied. Figure 11 below

shows an image of the control algorithm written in Simulink for the seat and lumbar actuators.

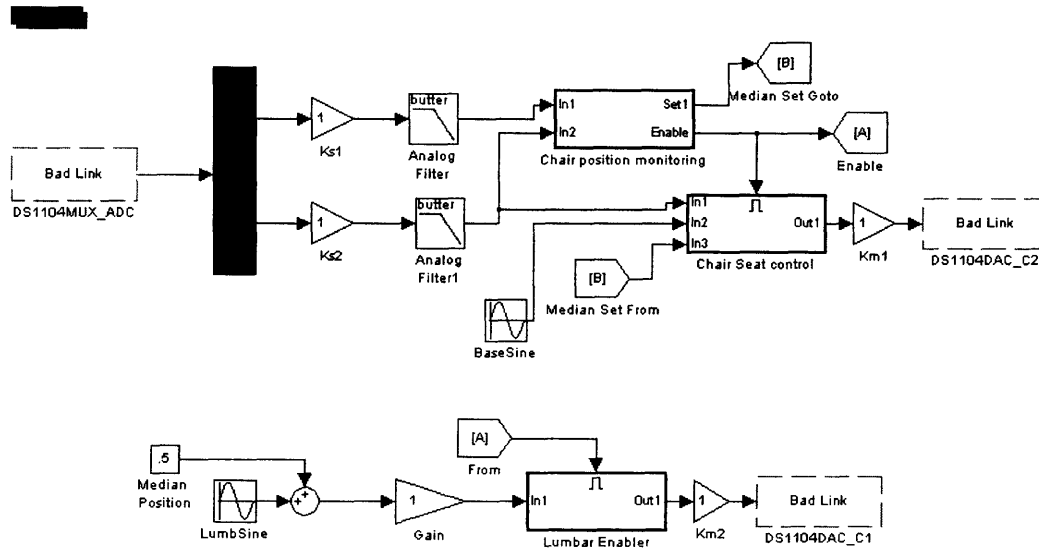

Figure 11: Block diagram of control system implemented in Matlab Simulink.

4.2.1 Lumbar Support Control System

The main control system for the lumbar support is relatively simple; the output voltage is directly proportional to the desired force. The motor amplifier was set to its maximum of 20V peak, resulting in a peak force of roughly 8 lbs. A secondary untested module for the control system is the position monitoring block, pictured in figure 12 below. The position monitoring block checks the position of the lumbar support, and determines whether or not the chair user is applying pressure to the support, and thus maintaining proper contact with it to maintain lumbar lordosis. If the support remains uncompressed for a time T , the control box passes a signal to the chair seat motion control block to move the center position of the chair backwards 0.5in, pushing the user back into contact with the lumbar support. Future versions of the chair with force sensing capability could use that instead as a contact indicator.

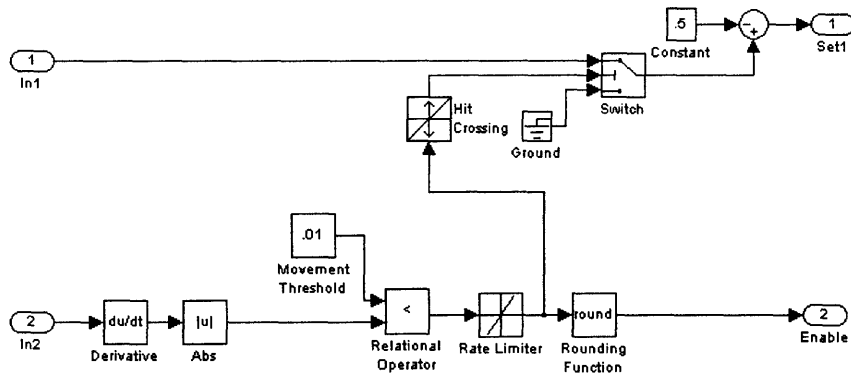

Figure 12: Position monitoring block

Several force profiles were tested for feel in the chair. First, the desired force profile was set in testing to 1 rad/s, roughly the rate of human breathing when at rest. This profile results in a noticeable but soothing motion in the back of the chair. Additionally, a profile of tested was a 0.01 rad/s oscillation which results in a very slow change in the force applied to the lumbar support. The change is not consciously noticeable, but did result in a gradual change in angle of the lumbar. Further testing with a spinal monitoring system would be needed to quantify the change.

The seat control system is a simple PID control system. Since motion occurs at a very low rate on this axis, less than 1 rad/s maximum, non-linearities in the system should not affect the quality of control. The control system was successfully used on an unloaded chair to position the seat. The motion appeared to be smooth and stable with a position dominated control plan, however further testing is required to determine its effectiveness with varying loads of different users. Although suitable for an unloaded chair, the PID control system may require variable gains for different weight users. Figure 13 below shows an image of the Simulink block diagram of the seat control system.

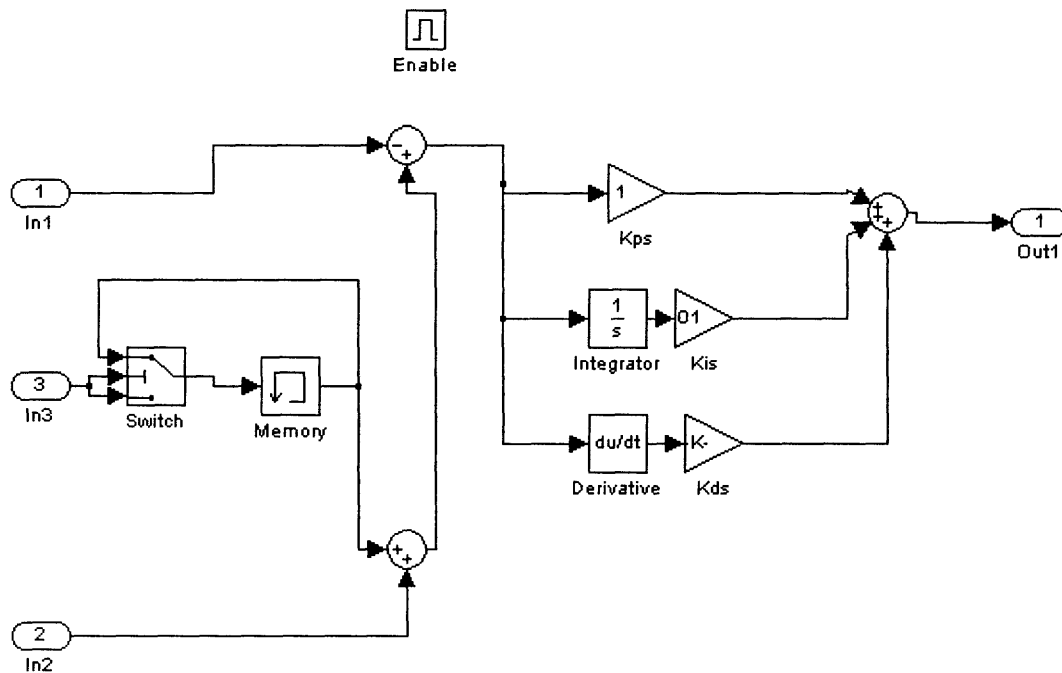

Figure 13: Seat PID control system. Switch-Memory block holds set position until new set position is input.

The control path is started by the seat position transducer sensing a change in position of the seat. The control system begins by taking the initial position of the chair and setting that value minus half an inch as the median value of the oscillation function. After observing occupants of a passive version of the chair, it appears that many users fail to fully apply pressure to the lumbar support, thus moving the seat backwards half an inch results in a more proper application of force to the seat back. The control path then oscillates at a set rate unless its median position is altered by the lumbar position monitoring block. If a user gets out of the chair, the control system will turn itself off after the lumbar position monitoring block has not detected a change in the lumbar position after a readjustment of the seat position.

5.0 Results and Discussion:

5.1 Results

In summary, a Leap™ chair was modified to include two active ergonomic components, the seat position, and the lumbar support force. The two components were controlled by one voice coil actuator each, and monitored by one position transducer each. One actuator was designed specifically for the seat motion of the chair, while the second actuator was harvested from an existing robotic arm. The chair body itself was modified in two ways. First, aluminum brackets were added to the chair to serve as actuator and sensor mounting points. Second, the seat position bushing was removed and replaced with a ball bearing track system. A basic control system for the seat motion was written in Matlab Simulink, and implemented through a dSPACE I/O board. The control system for the lumbar support was tested on users, while the control system for the seat position was tested on the unloaded seat.

5.2 Discussion

In human testing of the lumbar support motion, the support proved at the very least to be very comfortable. The addition of motion to the support added to its passively ergonomic design. Although it is unclear without further testing whether or not significant injury prevention would result from this added motion, past work on the subject of ergonomics and sitting suggest that constant motion is a great benefit those required to sit for long periods of time⁵. With respect to the seat motion, unfortunately the ball bearing slide was broken by inappropriate use before testing of the system could be done with human subjects. Despite this, testing with the lumbar support alone showed promising results for VCA actuators in this human interface application. Unlike a

⁵ D. L. van Deursen, M. Lengsfeld, C. J. Snijders, J. J. M. Evers and R. H. M. Goossens, Mechanical effects of continuous passive motion on the lumbar spine in seating, *Journal of Biomechanics*, Volume 33, Issue 6, June 2000, Pages 695-699.
(<http://www.sciencedirect.com/science/article/B6T82-408JKS4-7/2/88bafc5b3b436b39bda46f9a54eacale>)

mechanism actuated by gear-motor system, the force motion resulting from this arrangement was physically smooth, silent, and completely safe. Not only does a user feel comfortable with sitting in the chair, but should also forget that robotic components operate some of its motions.

Although VCA's were quite successful in implementing smooth motion in the chair, this project did reveal several deficiencies of current voice coil technology. The large strain required for the seat actuator resulted in a very low efficiency due to the large number of extraneous coils. The inefficiency of VCAs at low speed also brings into question their ability to hold the position of the seat for long periods of time without risk of overheating. Potential solutions to this problem include research into higher efficiency VCAs, as well as replacing the seat actuator with another type of linear actuator, such as a ball screw actuator. Although a ball screw will not be back-drivable, testing seems to show that a non-back-drivable seat would be acceptable. Unlike an acme lead screw, a ball screw actuator could be silent and smooth, which are the two main desirable characteristics of the voice coil when applied to this motion.

6.0 Future Work and Conclusion:

6.1 Future Work

A number of improvements and modifications should be made to this proof of concept in order for it to become a fully functioning prototype. To combat the issue of low efficiency at high strain, a commutated voice coil could be constructed. A commutated voice coil would consist of multiple sets of separately controlled coils, which could be independently turned on and off, thus only flowing current through coils with a significant magnetic flux. If properly developed, a commutated system could drastically reduce the electrical energy wasted in the very large coil, eliminating the relationship between strain and efficiency, and eliminating the maximum strain of 0.5.

Several modifications should also be made to the chair to improve its function and durability. The single base actuator should be replaced by two slightly smaller actuators, and relocated to mounting points closer to parallel with the seat base, perhaps in between

the armrest structure and the seat base structure on either side of the seat. This would reduce the torsional load on the bearing structure of the seat joint, and result in a higher effective actuator force. The seat joint itself is currently under reconstruction. This joint should be tested for loads in different positions on the seat to ensure that a human occupant in various positions will not damage the joint.

Finally, a sensing system should be added to the seat itself to provide force feedback, and information on user seating position. With a map of the user's load distribution on the seat, the chair's moving units could be positioned to better suit the user's position. In addition, the chair's moving parts could be used to jiggle the user out of bad seating habits. This sensing system's outputs could be integrated with the existing dSPACE control module. Additional controls could also be added to the chair, including automation for the Leap™ chair's seat shape change, as well as the back tension adjustment.

6.2 Conclusion

The implementation of voice coil actuators in the Leap™ chair proved that voice coils can provide smooth organic motion in human interface objects, as well as improve the ergonomic feel of a high end office chair. Further, this project provided more evidence that voice coil actuators are feasible for producing moderate forces in objects with an external power source. All actuators used in this project were very simple to construct, and were far less expensive than comparable rotary driven electromechanical actuators. With some further development, the chair could prove a valuable prototype for future active office furniture development.

References:

- D. L. van Deursen, M. Lengsfeld, C. J. Snijders, J. J. M. Evers and R. H. M. Goossens, Mechanical effects of continuous passive motion on the lumbar spine in seating, *Journal of Biomechanics*, Volume 33, Issue 6, June 2000, Pages 695-699.
(<http://www.sciencedirect.com/science/article/B6T82-408JKS4-7/2/88bafc5b3b436b39bda46f9a54eacale>)
- L.L. van Deursen, D.L. van Deursen, C.J. Snijders and H.J. Wilke, Relationship between everyday activities and spinal shrinkage, *Clinical Biomechanics*, Volume 20, Issue 5, June 2005, Pages 547-550.
(<http://www.sciencedirect.com/science/article/B6T59-4FKYF01-3/2/80f00b467a378a2b946896f57b975048>)
- M. Lengsfeld, A. Frank, D. L. van Deursen and P. Griss, Lumbar spine curvature during office chair sitting, *Medical Engineering & Physics*, Volume 22, Issue 9, November 2000, Pages 665-669.
(<http://www.sciencedirect.com/science/article/B6T9K-42JYTTF-8/2/82ed102eacbfd372ff96a922f998f1c>)
- R. S. Bridger, D. Orkin and M. Henneberg, A quantitative investigation of lumbar and pelvic postures in standing and sitting: Interrelationships with body position and hip muscle length, *International Journal of Industrial Ergonomics*, Volume 9, Issue 3, May 1992, Pages 235-244.
(<http://www.sciencedirect.com/science/article/B6V31-482B0KJ-2P/2/468add98bd8235c8d57ffcd828e60ed1>)
- John M. McBean, *Design and Control of a Voice Coil Actuated Robot Arm for Human-Robot Interaction*, © 2004 Massachusetts Institute of Technology