

Sonification of the Invisible: Large Scale Sound Installments on Building Facades

by

Carrie Bodle

B. F. A. Art and Technology
The Ohio State University, 2002

SUBMITTED TO THE DEPARTMENT OF ARCHITECTURE IN PARTIAL FULFILLMENT OF THE
REQUIREMENTS FOR THE DEGREE OF

MASTER OF SCIENCE IN VISUAL STUDIES
AT THE
MASSACHUSETTS INSTITUTE OF TECHNOLOGY

JUNE 2005

©2005 Carrie Bodle. All rights reserved.

The author hereby grants MIT permission to reproduce and to distribute publicly paper
and electronic copies of this thesis document in whole or in part.

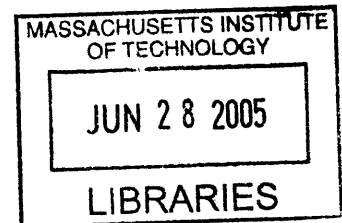

Signature of the Author: _____
Carrie Bodle, Department of Architecture
May 06, 2005

Certified by: _____
Krzysztof Wodiczko
Professor of Visual Arts
Thesis Supervisor

Accepted by: _____
Adèle Naudé Santos
Chair, Committee on Graduate Students
Acting Head, Department of Architecture
Dean, School of Architecture and Planning

ROTCH



Room 14-0551
77 Massachusetts Avenue
Cambridge, MA 02139
Ph: 617.253.2800
Email: docs@mit.edu
<http://libraries.mit.edu/docs>

DISCLAIMER OF QUALITY

Due to the condition of the original material, there are unavoidable flaws in this reproduction. We have made every effort possible to provide you with the best copy available. If you are dissatisfied with this product and find it unusable, please contact Document Services as soon as possible.

Thank you.

This thesis contains pagination errors. Pages 50 - 52 do not exist.

**Sonification of the Invisible:
Large Scale Sound Installments on Building Facades**

by

Carrie Bodle

Submitted to the Department of Architecture on May 6th, 2005 in Partial Fulfillment of the Requirements for the Degree of Master of Science in Visual Studies

ABSTRACT

The intention of this project is to utilize sound as representation of MIT research—extending out to the public what may be invisible, or less known to the broader community interested in MIT's spectrum of work. I am utilizing Building 54, also known as the Green Building, on the MIT campus to address the public and MIT community through a vehicle of transmission utilizing sound as representation of research here at MIT.

Collaborating with scientists from MIT's Haystack Observatory, I am proposing the sonic display of research data from an architectural scale, a speaker setup on the south façade of the Green Building. This project will be a multi-speaker sound installment with a total of 35 Public Address speakers temporarily attached to the vertical concrete columns on the buildings' façade. The speakers will be broadcasting audio representations of sound waves embedded in Earth's charged upper atmosphere, or ionosphere. These sounds make tangible the state of the ionospheric portion of the terrestrial upper atmosphere, a region under active radar study by the Atmospheric Sciences Group at MIT's Haystack Observatory. The speaker arrangement on the Green Building's façade visually reminds the listener of an upwards-sloping graph. This is representative of the spectral frequency distribution of the sounds, which vary both by time and in altitude.

This large-scale sound installment will make tangible the converging perspectives of contemporary arts and upper atmospheric science, representative for the advanced research focus of this institution, and exemplary for MIT's interests in creating an environment in which the arts merge with technology to create inspirations for artists and scientist likewise. The scale of this project is considerable, but so is the size of the Haystack Observatory installation, the distance to the ionosphere, and the iconic silhouette of the Green Building overseeing the MIT campus when viewed from the Boston bank of the Charles River.

Thesis Supervisor: Krzysztof Wodiczko
Title: Professor of Visual Arts

My Deepest Regards to

**Axel Roesler
Phil Erickson
David Barber
Jim Harrington**

CONTENTS

Chapter 1

- 13** Sonifiction of the Invisible: Proposal for the realization of a large scale sound installment on the south facade of the Green Building
- 14** Sound detail
- 19** Hanging detail
- 25** Exhibition detail

Chapter 2

- 29** Sonic Arts History
- 34** Allowing Architecture to Speak
- 41** The Green Building
- 45** Sound as Propaganda

Chapter 3

- 49** Project in Progress
- 58** Bibliography
- 60** Photo credits





Speakers are distributed accross the facade of Building 54. Pipe clamp bracket systems are used to temporarily attach the speakers to the vertical columns of the building.





Chapter 1

Sonification of the Invisible:

Proposal for the realization of a large scale sound installment on the south facade of the Green Building

The intention of this project is to utilize sound as representation of MIT research—extending out to the public what may be invisible, or less known to the broader community interested in MIT’s spectrum of work. I am utilizing Building 54, also known as the Green Building, on the MIT campus to address the public and MIT community in an abstract representation of research going on here at MIT. Collaborating with scientists from MIT’s Haystack Observatory, I am proposing the sonic display of research data from an architectural scale, a speaker setup on the south façade of the Green Building. This project will be a multi-speaker sound installment with a total of 35 Public Address speakers temporarily attached to the vertical concrete columns on the buildings’ façade.

The speakers will be broadcasting audio representations of sound waves embedded in Earth’s charged upper atmosphere, or ionosphere. The broadcast sounds are in fact frequency scaled versions of ion-acoustic pressure waves within the hot ionospheric gas, which changes state in a complex interaction with the Sun’s varying output. Physical parameters appropriate to seven different altitude levels in the ionosphere will be used to construct appropriate ion-acoustic sounds, and these will be broadcast from seven layers of speakers on the facade of the Green building. These sounds make tangible the state of the ionospheric portion of the terrestrial upper atmosphere, a region under active radar study by the Atmospheric Sciences Group at MIT’s Haystack Observatory.

Sponsored by the National Science Foundation, MIT Haystack

is currently the only observatory located in the Continental United States which uses this powerful ground-based sensing technique to map changes in the makeup of the ionosphere. Such changes, especially during disturbed periods, can affect the precision of GPS technology and other man-made long distance and satellite transmissions. Knowing and predicting the constitution of the ionosphere has become an integral interest for commercial interests as well as the national Space Weather effort funded by the National Science Foundation, and puts a spotlight on nearly five decades of study by the Haystack research group at MIT.

The speaker arrangement on the Green Building's façade visually reminds the listener of an upwards-sloping graph. This is representative of the spectral frequency distribution of the sounds, which vary both by time and in altitude.

This large-scale sound installment will make tangible the joint perspectives of contemporary arts and upper atmospheric science, representative for the advanced research focus of this institution, and exemplary for MIT's interests in creating an environment in which the arts merge with technology to create inspirations for artists and scientist likewise. The scale of this project is considerable, but so is the size of the Haystack observatory installation, the distance to the ionosphere, and the iconic silhouette of the Green building overseeing the MIT campus when viewed from the Boston bank of the Charles River.

This project has been developed in collaboration with Dr. Philip Erickson at the MIT Haystack Observatory. Dr. Erickson has provided the transposition of ionospheric data that forms the basis for the 35 channel sound content of the piece. The following part describes the transposition this data into audible patterns.

Sound detail

The sound of the project will consist of 35 audio channels across the façade of Building 54 (see detail). The speakers will represent the temporal change of conditions in the plasma which composes the ionosphere, a layer of the upper atmosphere that starts at an altitude of approximately 100 kilometers (60 miles) above ground. For the purposes of this project, the thickness of the ionosphere is subdivided into 7 layers.

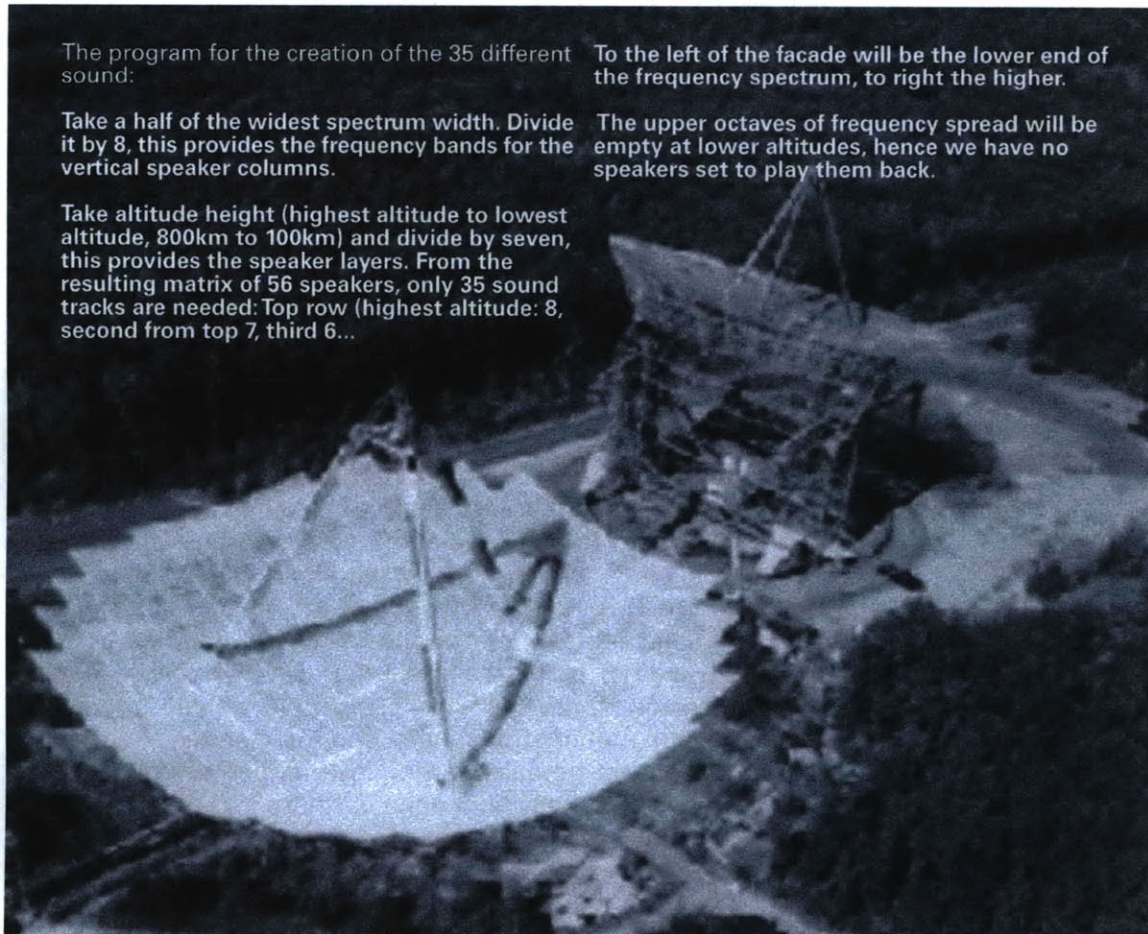

The program for the creation of the 35 different sound:

To the left of the facade will be the lower end of the frequency spectrum, to right the higher.

Take a half of the widest spectrum width. Divide it by 8, this provides the frequency bands for the vertical speaker columns.

The upper octaves of frequency spread will be empty at lower altitudes, hence we have no speakers set to play them back.

Take altitude height (highest altitude to lowest altitude, 800km to 100km) and divide by seven, this provides the speaker layers. From the resulting matrix of 56 speakers, only 35 sound tracks are needed: Top row (highest altitude: 8, second from top 7, third 6...

The Millstone Hill Observatory, the radar installation from which surveys of the ionosphere are conducted as part of the MIT Haystack Observatory.

Each of the 7 horizontal speaker rows will sonically reflect the current composition and temperature of electrons and ions at a specific altitude, analogous to the elevation of the rows from the ground on the Green building. The vertical extent of the Green building façade becomes a representation of the ionosphere layer.

The sound that will be broadcast from the speakers is based on a translation of ion pressure waves within the ionospheric gas, transposed into audible frequency range. These pressure waves have a characteristic frequency spread which depends on the composition and temperature of the ionospheric gas itself.

The sound will vary from left to right to represent different discrete frequency bands from within the frequency spectrum of the sound translation. The bands will increase in frequency

range from the left to the right. The distribution of speakers on the façade reflects the frequency distribution of the sound generated from the ionosphere pressure waves and the subdivision into different altitudes: Higher altitudes contain a characteristically wider ion-acoustic spectrum since masses are lighter and temperatures hotter there, while lower altitudes are narrower spectra typical of heavier ions and lower temperatures.

The conditions within the ionosphere undergo temporal change that will affect the sonic representations at all altitudes. The temporal variations of electron and ionic density in the ionosphere layer have complex physical responses which at lower altitudes have nearly tidal patterns, as the charged and neutral portions of the atmosphere interact with each other. Major influences on the make-up of the ionosphere are large variations both in solar radiation and in particle emission of the sun's outer atmosphere, resulting from magnetic variations within the gaseous body of the sun. Solar winds, the term for this solar atmosphere outflow which buffets the planets, create waves of highly energetic particles which can greatly affect the ionosphere. A visible example of this interaction between sun, upper atmosphere, and the magnetic field of the earth are aurora borealis, large glowing displays that can be seen in the sky usually above the northern and southern poles of earth and even sometimes over North America (for more information of ionospheric conditions and the interaction between sun and earth, see www.spaceweather.com). Relevant to this project, in an expanded sense of meaning, the sound structures emitted by the speakers on the façade will make audible the interactions between the sun and the earth in terms of ionospheric particle and radiation influence caused by solar radiation and solar winds - in a broader sense the audible channels broadcast by the speaker field sonify the effects of solar winds on earth. The sounds are specifically representative of ion-acoustic spectra in the ionospheric gas, scaled in frequency, with physical parameters appropriate to the altitude in question.

The data behind the calculation of the audible sound, done by collaborating scientist Dr. Philip Erickson at the Millstone Hill Observatory which is a part of MIT's Haystack Observatory, Westford, MA, stems from a large database of ionospheric studies conducted at Haystack Observatory over the past five decades using the powerful ground-based technique of incoherent scatter radar. An empirical model constructed from this

data by Dr. Shunrong Zhang, also at MIT Haystack, allows for the calculation of a typical average ionospheric state (relative amounts and temperatures of electrons and ions in a given volume of ionospheric gas at different altitudes) for exactly the time frame the sounds are on display. In a statistical sense, what is audible is a representation of the physics taking place at this moment, approximately 100 to 600 kilometers above the Green building on the MIT campus.

MIT Haystack Observatory is one of four installations funded by the Upper Atmospheric Facilities division of the National Science Foundation to conduct ionospheric studies using powerful radars, and the Atmospheric Sciences Group at MIT Haystack is the only observatory in the Continental United States dedicated to this research technique. Ionospheric research is becoming increasingly important to our technology-dependent society, as changes in the makeup of the ionosphere affect the precision of GPS technology and under severe conditions can disrupt radio transmissions or any type of broadcast relayed by satellite. Knowing and predicting the composition of the ionosphere (an effort known as Space Weather forecasting) has become an integral interest for the military and commercial sector, and plays a key role in the reliability of fundamental communication requirements.

Ionospheric studies have been conducted since the beginning of the space era by dedicated groups and have recently been the focus of intense public outreach and growing public interest in both the natural and human consequences of Space Weather events. By connecting ionospheric research with this large scale sound installation, we hope to build bridges between state of the art research and contemporary art at MIT that are audible and visible to the art interested community that MIT attracts.

We have determined that the audible levels in the area of the Building 54 will not exceed a tolerable decibel amount that takes into consideration the occupants of the Green building and its neighboring facilities. We are currently in the process of acquiring wind distribution data of the building environment which will help us determine the boundary conditions for the sound distributions.

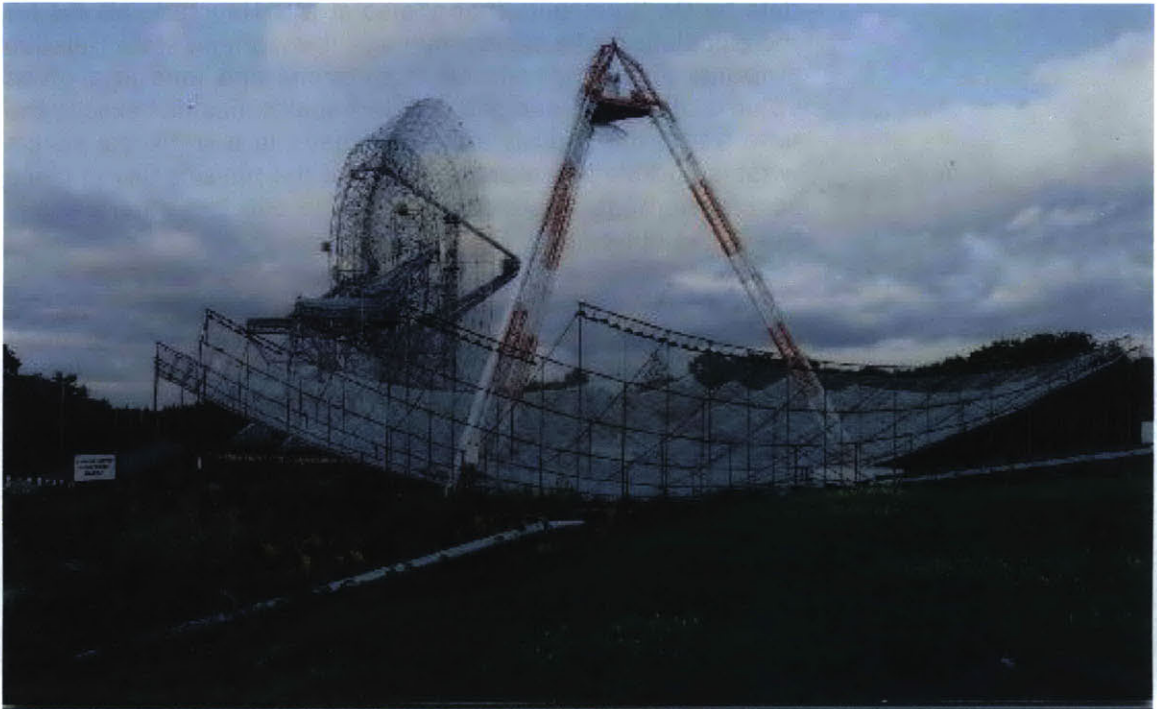

(above) The incoherent scatter radar antennas at the Millstone Hill Observatory

(below) The 9 incoherent scatter radar installations worldwide

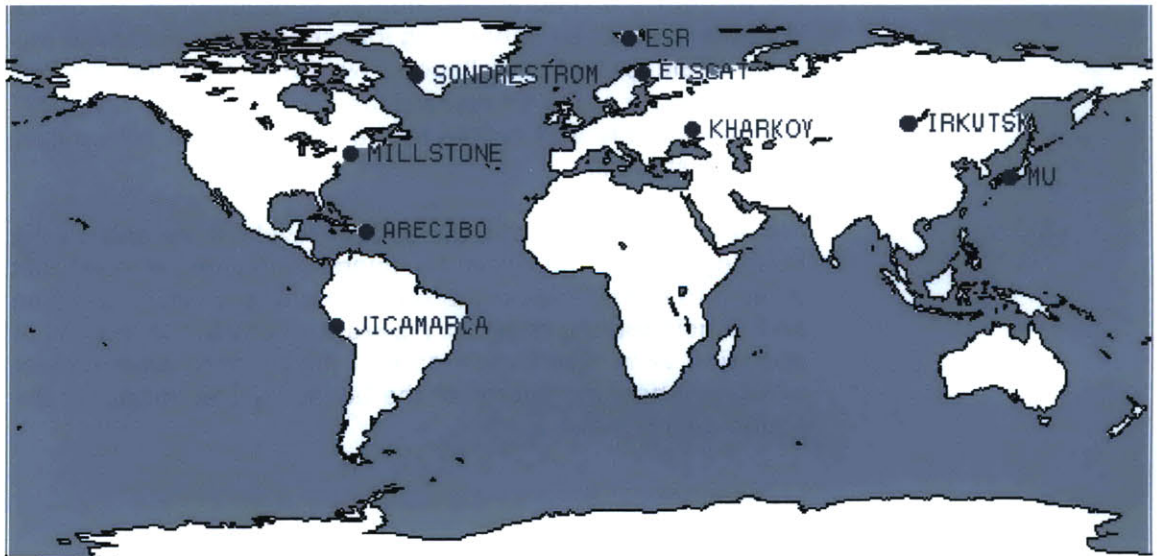

Hanging detail

Installation of speakers will begin on Monday May 2, 2005. Installation will take two weeks, being completed by Friday, May 13, 2005. Completion of the speaker installation will coincide with my Master's Thesis Review and the Visual Arts Program Open House, Friday May 13-Sunday May 15, 2005. I would ask that the project be audible during my Thesis Oral Review (Friday May 13th from 3-4pm) and the Open House hours of 6-9pm on Friday May 13, 2005 and then return to regular agreed upon 'on times' on Saturday May 14, 2005.

Speaker Cabling will go to the roof of Building 54. 8 Safety steel cables will run along each vertical column to ensure speaker support in the unlikely case that local, 4-point attachment fails. Safety cable will be attached after speakers have been locally attached to building (see clamping system section). The Safety cable will be attached at existing fixation points on the roof. All contact areas of temporary speaker set up and building will be lined with cushioning pads to ensure that the building facade will not be damaged by speaker brackets or safety cables.

An exclusion zone will need to be sectioned off during the dates of the speaker hanging. This will entail an orange plastic snow fence suitable for the fall area around the northeastern facade of Building 54. Hard hats and safety glasses will be worn at all times in and around the work area.

The hired hanger for the speakers will be trained in OSHA standards for fall protection with specific knowledge in window washing and/or building maintenance. Full body harness will be worn by the hanger and helper on the roof. The securement will meet the requirements put forth by the MIT Health and Safety Department.

speaker / bracket assembly

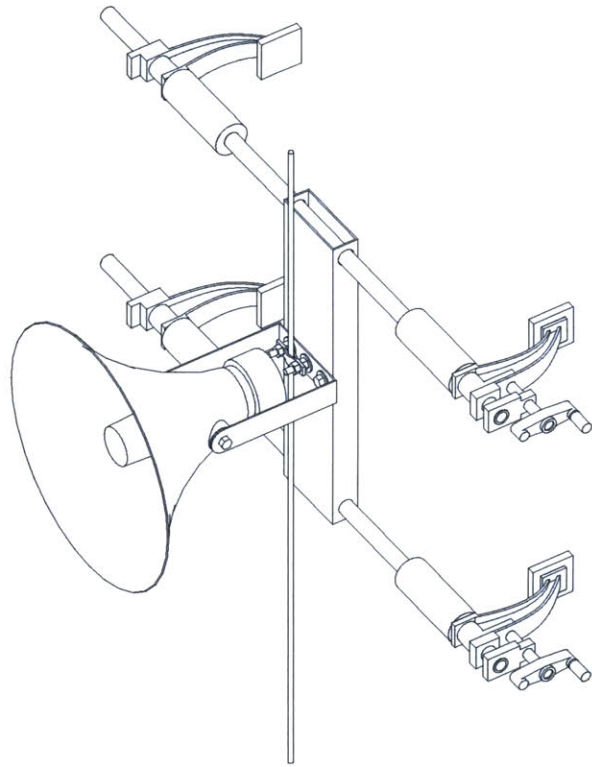

Public address speaker, attached to the vertical column of the Green Building using a double pipe clamp bracket.

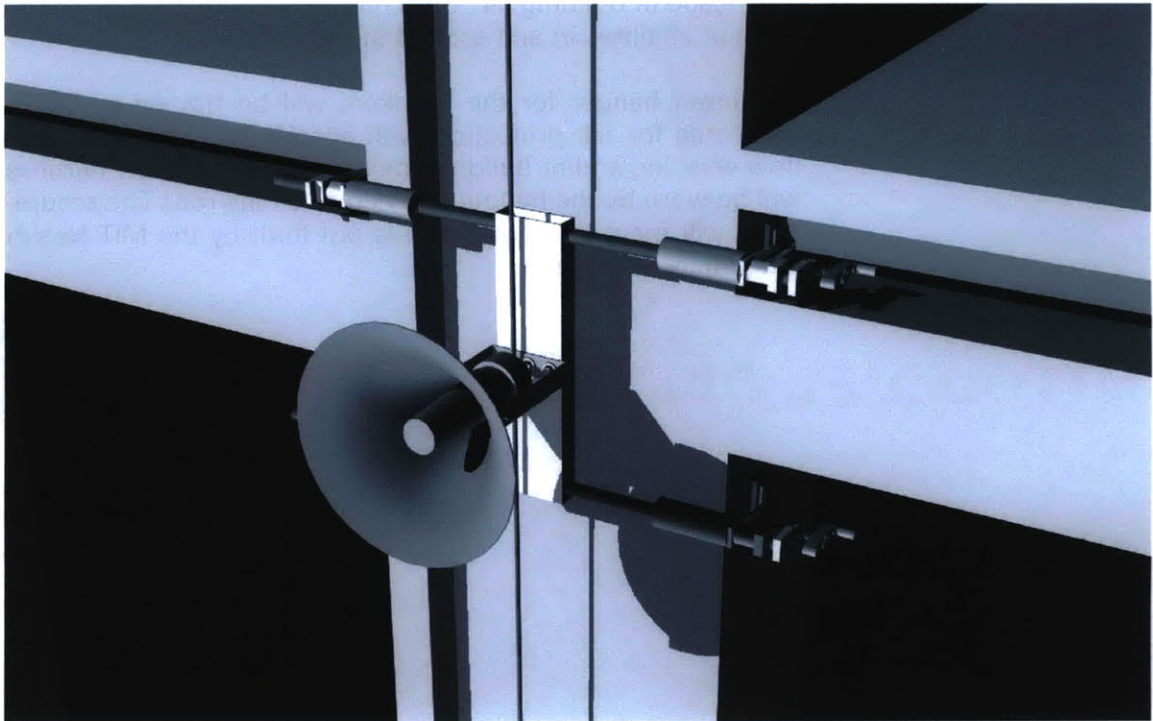

*Early design sketches for the
speaker clamp*

Sketches by Axel Roesler

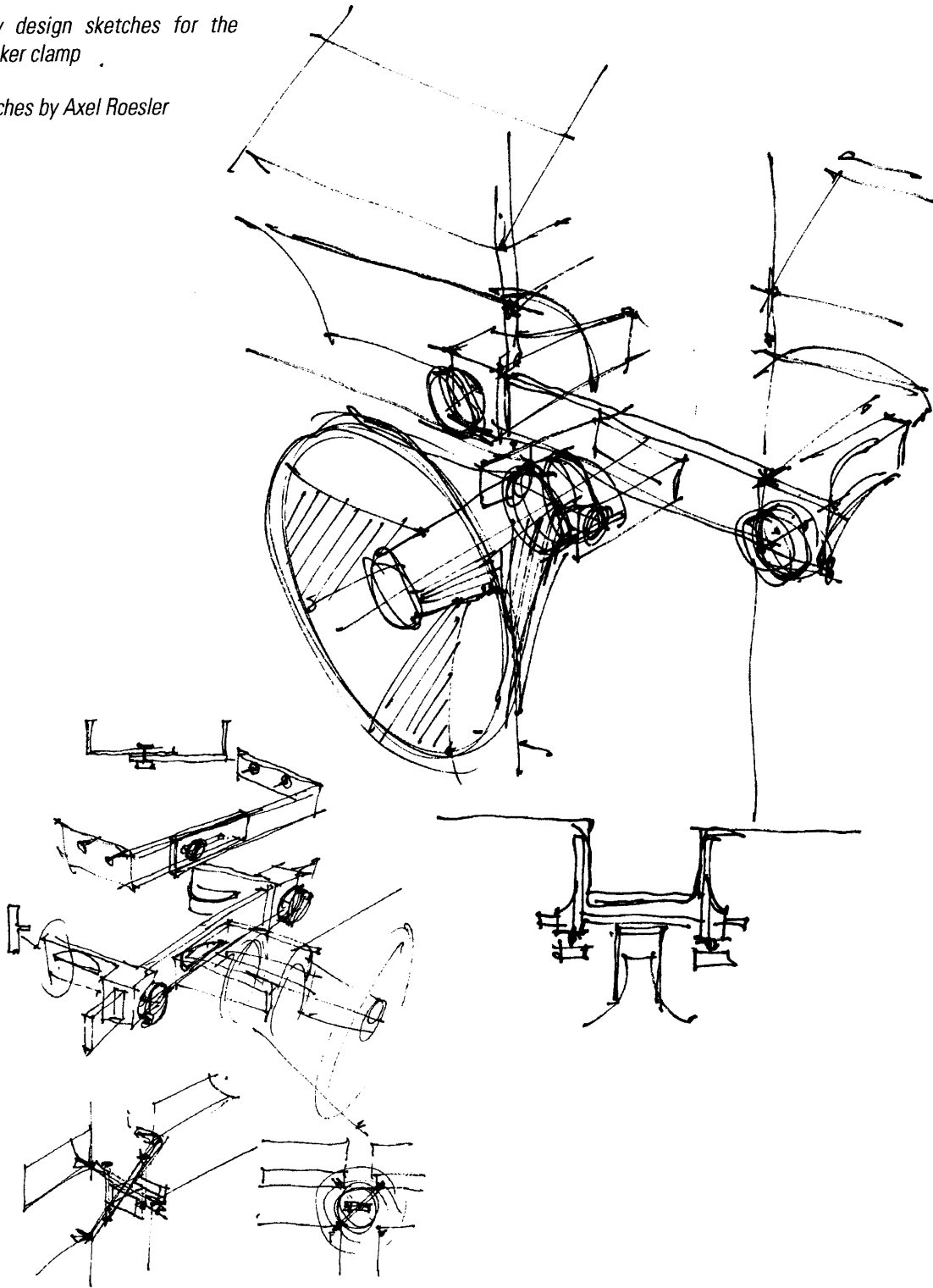

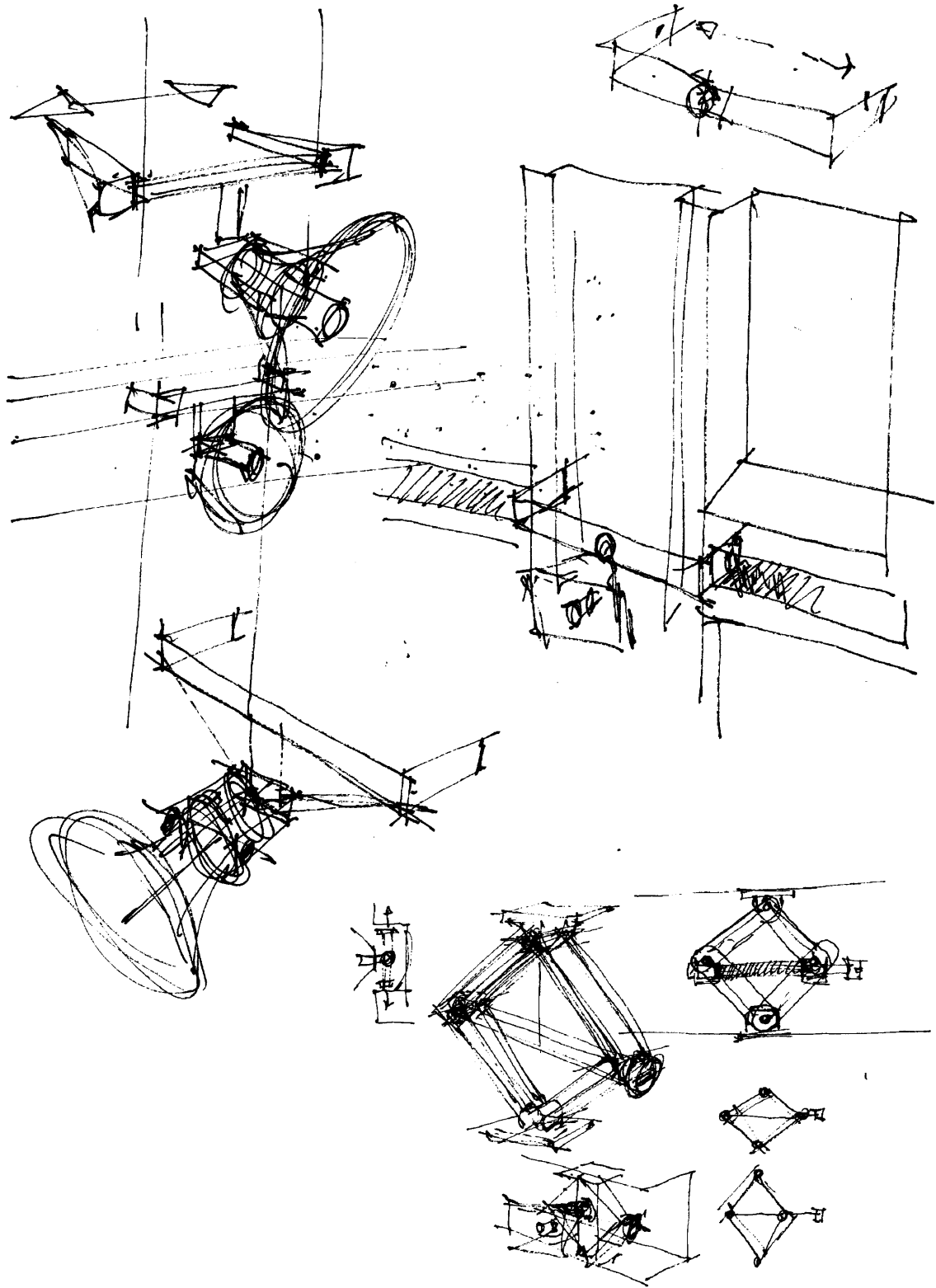

Speaker arrangement on the south facade of Building 54

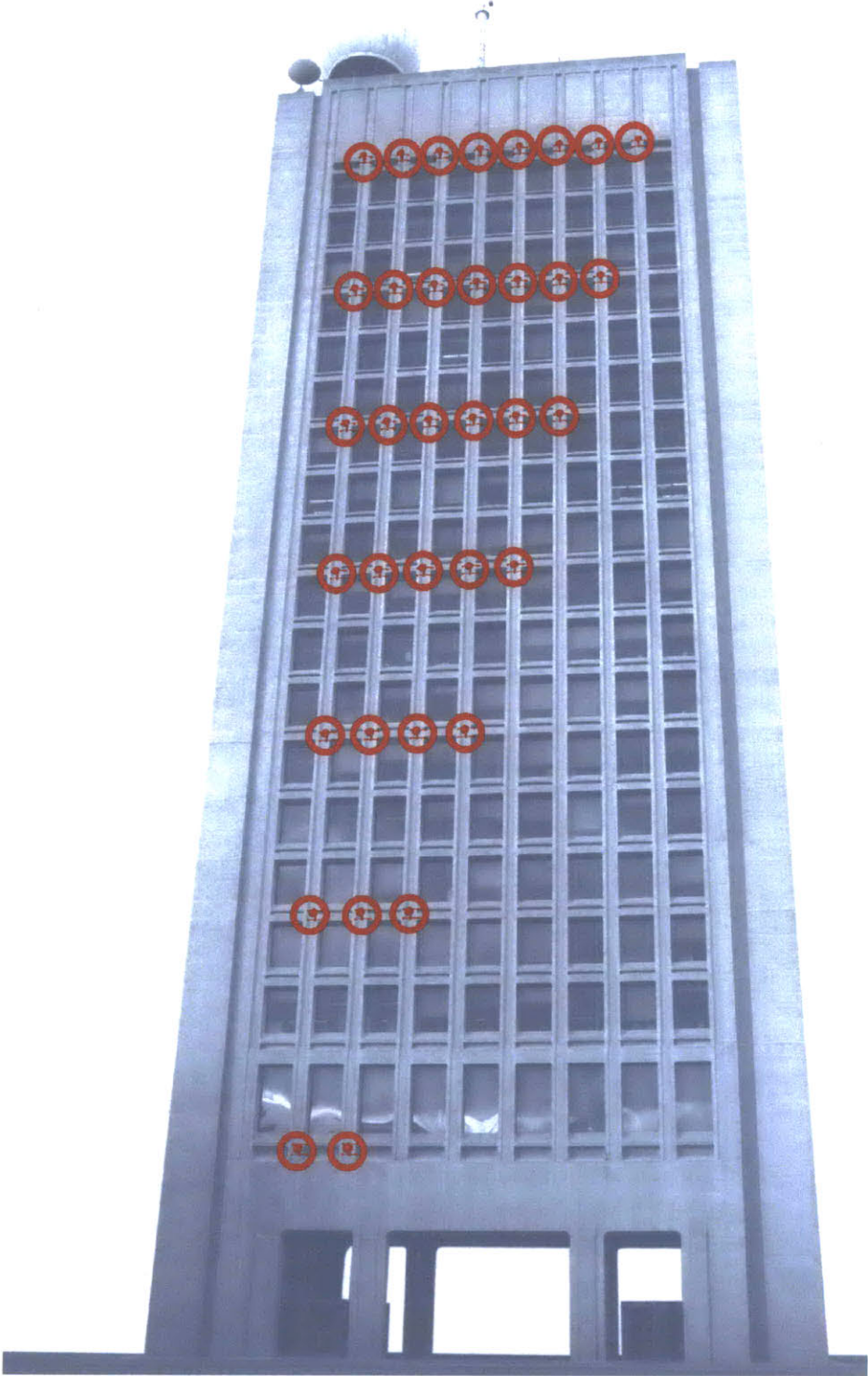

*View up with
35 speakers attached*



Exhibition details

I am proposing that the project is set up to be heard at particular times of the day agreed upon by the Institute. My suggestion at this point is 1 hour each day of the week from 2pm to 3pm, with an option to extend this period once the piece is installed and all parties in close proximity have a chance to verify the unobtrusive character of the piece.

There will be an information site at the base of the building with information regarding the sounds being heard, the story of the project, pamphlets of MIT Haystack Observatory, and exhibition details. These printed documents will reside in a pamphlet holder with a flashing led sign regarding next hearing time as well as information about the sounds. The information area will be located on the inside one of the large windows next to the revolving doors, visible and readable from the outside, with the pamphlet holder temporarily attached on the outside, using suction cups.

In all planning and detailing stages of the project installation, it is my first objective to not alter or damage any part of the building by permanent fixtures or modifications.

The project will be installed in completion by Friday, May 13, 2005 and I propose that the project be up for 1 month, ending on Friday, June 17, 2005.

Speaker clamp dimensions

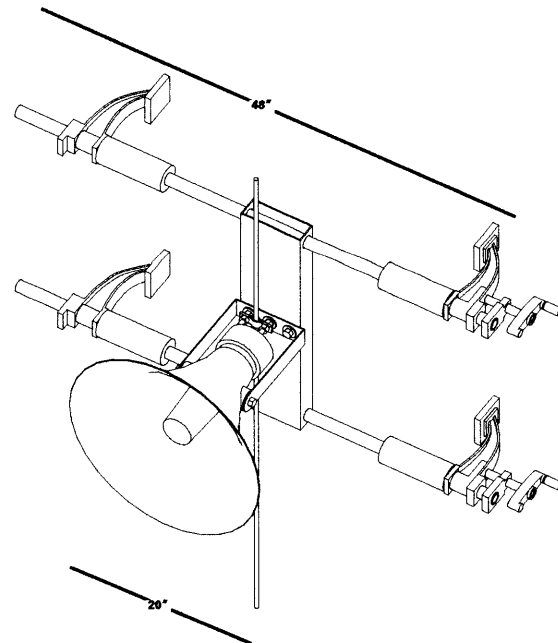

Speaker Clamp Details



.375" steel safety cable attached to the bracket (detail)

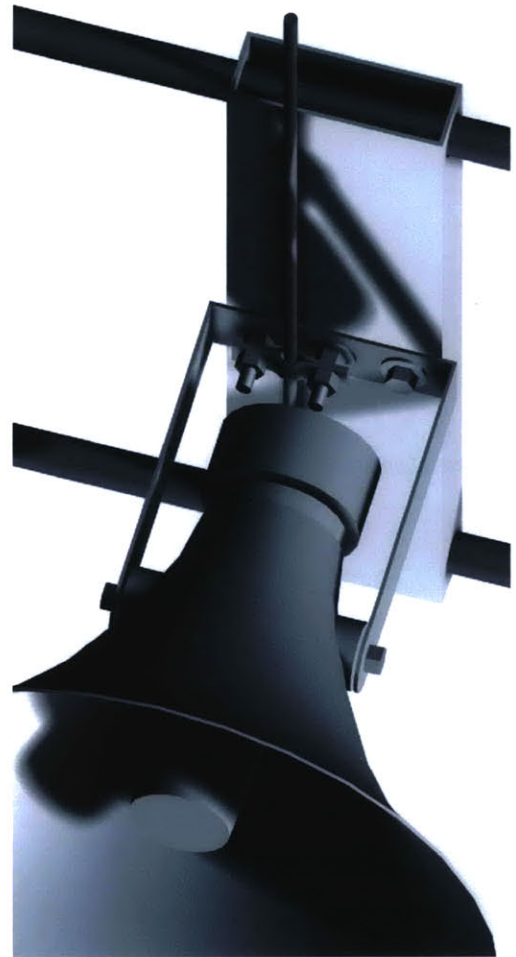
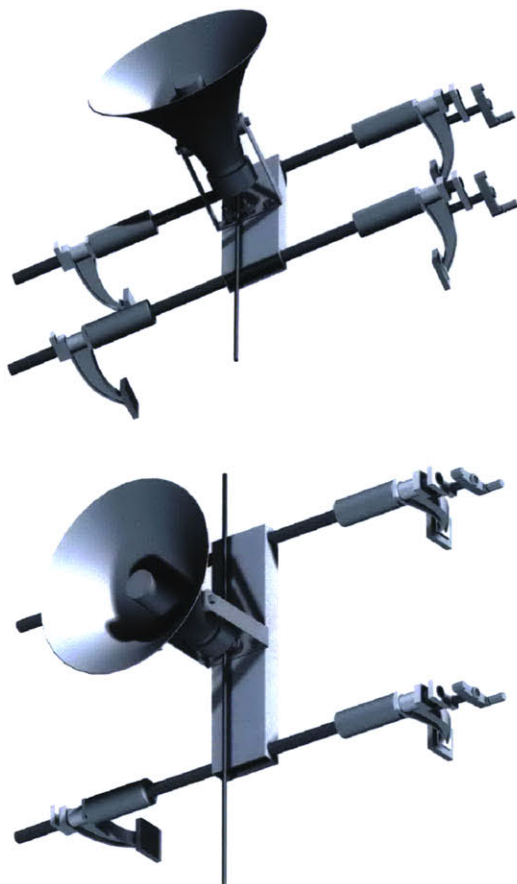

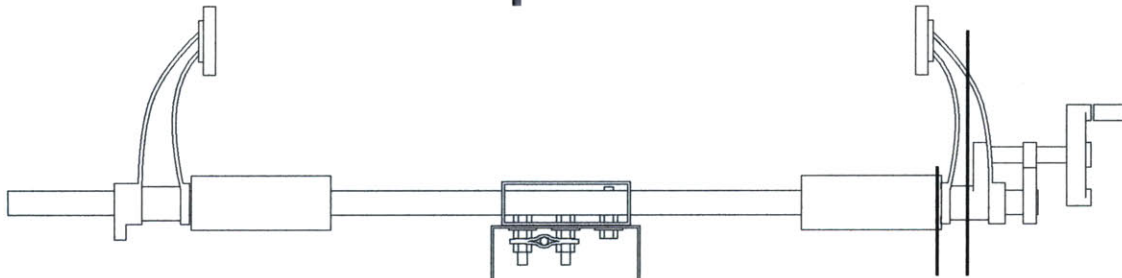

Speaker clamp details

cushion pads to protect building facade from marks

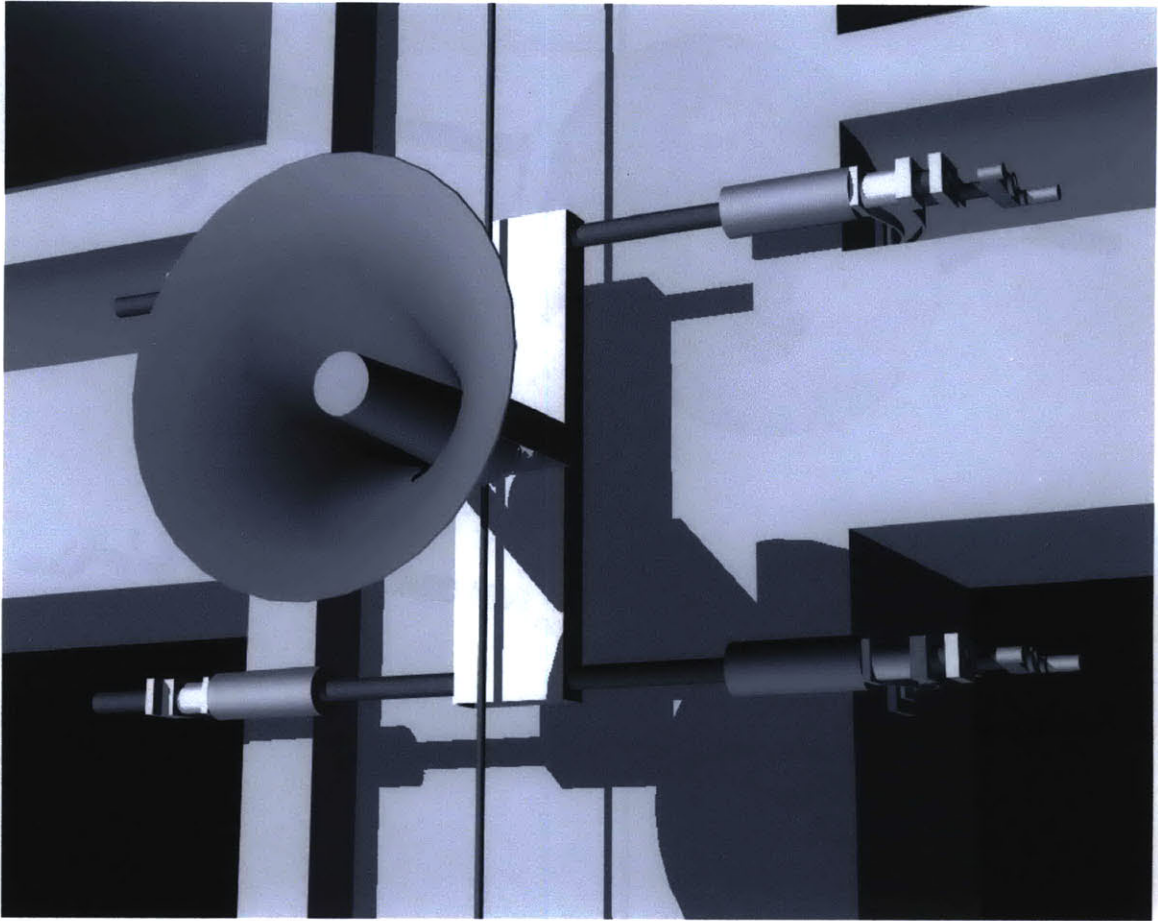

(above) Speaker clamp attached to the Green Building (Detail)



(right) Prototype of the speaker clamp during testing

Chapter 2

Sound art history

The history of sound as a medium in art originates like photography and film with the invention of new technology – the means necessary to record and play back sound information. Before this technology was invented – Edison received his patent for the phonograph in 1878 – the artistic concern in sound had been exemplified in music, and it would take 30 more years for the traditional mindset that was propagated in contemporary music at the time to nourish a new approach to the construction of sound relationships in the 12-tone music of Anton Webern, Arnold Schönberg, and Alban Berg. At the heart of 12-tone composition lay the idea of a program that would take notes into figures that despite disharmonic qualities would create adequate structure for music. As 12-tone composition had originated in the academic circle as a knowledgeable response to the apparent form limitations of classical music at the time, it was quickly considered an academic style. Challenging music from within the music discipline still remained to be difficult – too much in the music circles was under the control of the academies, orchestras and musicians, so a radical change in the treatment of sound as music had to come from elsewhere. The turn into the 20th century had brought many changes in mindset, and a period known as ‘The Eve Towards World War II’ laid the grounds for a revolution in the arts prior to the soon following political revolutions in the world. In painting, Cubism had developed and Kandinsky, Klee, and others went into Abstraction. Marcel Duchamp and a circle of artists in Paris were in the process of forming what would eventually become the Dada movement, Kasimir Malevich was exploring Suprematism, and El Lissitzky and Vladimir Tatlin were preparing the grounds for Russian Constructivism.



Thomas Edison with his phonograph, patented in 1878.

In the Netherlands, Theo Van Doesburg and Gerrit Rietveld formed the De Stijl movement, and Germany soon would see the opening of the first Bauhaus in Weimar and the formation of the German Dada circle around Kurt Schwitters, Hugo Ball, and Max Ernst.

In Italy, the Futurists would propagate the themes of progress in the form of noise, destruction, speed and ecstasy. The group was one of the first to make use of sound as art medium, not as music, but as something else that stood in its own right. As art form, sound had not to carry the heritage of music, nor did it have to struggle to be different enough. Luigi Russolo's manifesto 'The Art of Noise' (1913) proclaims the end of Western music and proposes its replacement with sound derived from grinding, crackling, and exploding instruments. From the Futurists perspective, life was constant warfare, in contrast the Dada movement put its focus on the opposite. In the harsh emotional and intellectual aftermath that hit Europe with the realization of dreams burning down, Dada saw its mission in the production of anti-art that would eventually destroy culture and in this way 'end all wars'.

Hugo Ball's Dada recording from 1916 spells in the voice of a baby, exemplary for Dada's use of naïve art forms in children's play and cave paintings. In Kurt Schwitters many views expressed in his concepts for total art, an audience for sounds had to be incorporated, actively involved in the creation of these sounds. Meanwhile, the music community devised a Renaissance of the harmonic structure, Neoclassicism, which in the consequence split up the academic music world into Experimental music and Neoclassical composition. Experiments lead into new terrain in music or away from music.

The magnetic tape recorder was invented by AEG in 1935. With the practice of recording sounds on tape, a new experimental music genre, classified into electronic music, Musique Concrete emerges. Pierre Schaeffer, a Paris radio broadcaster, created some of the first Musique Concrete pieces.

This form is the opposite to traditional music, where the piece is composed and then put into tones – Musique Concrete starts with a collection of sounds that are edited into musical structure. Magnetic tape was also visible time in Musique Concrete – through the tape one could see music existing in space, whereas the pure sounds existed in time. By shifting and distorting the geometry of the tape, music was arranged spatially, embedding the time-space component into music by varying speed and with it pitch in the sounds.

This ability to manipulate music material presented a sort of illusory control over space and time by musical arrangement that had addressed recorded sound, not orchestration of instruments.

The AEG Magnetophone, the first tape recorder (1935)



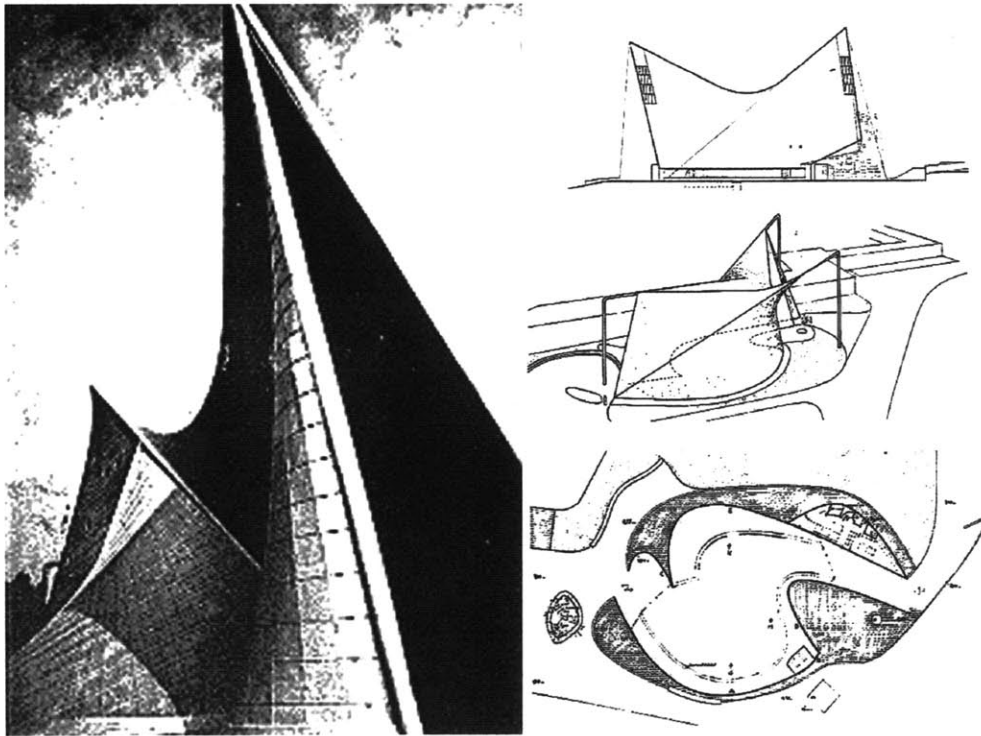

The Philips Pavillion by Yannis Xenakis and Le Corbusier at the Brussels World Fair, 1958

A milestone in the synthesis of music and space presents the Philips Pavilion at the World Fair in Brussels, 1958. It merges the architecture of Yannis Xenakis – generally attributed to Le Corbusier under whom Xenakis worked at the time – with a 400 speaker, spatial sound arrangement inside the tent like pavilion, mounted in “sound routes” running around the never before seen spatial configuration of the interior, and reciting Edgar Varese’s ‘Poem Electronique’, accompanied by multiple screen slide and film projections. This presentation of Musique Concrete in an architectural context is considered one of the first applications of music being literally projected into space.

In parallel to the French Musique Concrete circle, John Cage formulated his experimental music in the United States. Known as ‘chance music’ or ‘aleatoric music’, his compositions investigated and ironized the process of composing itself, leaving aspects and passages in the music up for chance, for random interventions, unintended but with consequences that would make Cage’s music the first example of musical composition that was set free from the authority of the composer. Cage’s 4’33” of silence marks the harshest departure from music, as by the absence of music, everything becomes music.

Cage was a member of the Fluxus group which blended different art genres, primarily visual, music, and literature. Most notorious for their performance work, the group explored experimental realms that had laid the foundations for a decentralized art form where the audience becomes collaborator and participant, and where the artist replaces control with chance.

American composer and sound artist Alvin Lucier, born 1931, went into yet new directions, as he put sound phenomena at the center of his explorations. His pieces investigate effects such as interference between sine waves, resonance, echo as the interplay between physical spaces and sound propagation through these, resulting in alteration of the sounds themselves. In 'I am sitting in a room' (1969) he recites a poem and records himself before re-recording the recording in the same room until the sound quality degrades into incomprehensible mumbling. He reacts with this deformation of sound to his own limitations in speaking, as the acoustic phenomenon becomes stuttering.

Bill Fontana, born 1947, uses the term sound sculptures for his work. He utilizes loudspeakers as sound sources which are distributed in space. The spatial arrangement includes programs such as relocating sound from point of origin and found sounds put in different context. Doing the latter, Fontana intends to "refocuses our experience of the acoustical environment and undermine our reliance on visual cognition."⁽¹⁾ Fontana works with sound installations in architectural contexts, but these become stages rather than reflections of the sound content staged. Sound in his work becomes a layer that is drawn upon something that had previously existed, as the difference between sound content and site becomes apparent.

(1) Bill Fontana: Acoustical Visions of Venice
By Matthew Drutt, online at URL
<http://www.resoundings.org/Pages/Acoustical%20Visions%20Essay%20.html>

Allowing Architecture to Speak

I strongly believe that all buildings have a voice. This voice speaks of a history, a present, and a future. It is an interior voice that speaks of inhabitants, social relations, and political motivations. I am drawn to these voices that are sometimes subtle and sensitive as they inhabit a space. This certain notion of spaces is already there, it wants to be listened to, and I feel as an artist that I have the means to amplify what the buildings have to say – to respond to the presence of time, past time in their stature.

The process to this work begins as an ambiguous, innate notion. A site is found, and then a piece evolves from site. I am working with buildings, architectural structure, as site, as this built environment echoes a need that has been present since the beginning of its conception. Any building has been devised for a reason, performs a function of either sheltering the activities that go on inside, hiding them, or presenting/representing them. The use of buildings turns these functions into spaces in which stories exist and memory is formed – concerning the events that took place, and the change that occurred over time and has transformed this site of activity – has either converted or has abandoned it. Buildings exist in different cycles – their lifetime extends over the lifetime of people, and appears short in respect to the cycles in nature. The buildings I have worked with so far are old, between hundred and seventy years – the age of an old person. Something like wisdom, or a long life full of experience may be attributed to them, as during their existence not only their inhabitants, but also the world in which these people have lived or live has changes. Another characteristic of the buildings that interest me is that these are not

private spaces, residences and homes or the like, but public or semi-public buildings – manufacturing places or places of study, inhabited by generations of people who spend a short segment of their life here. These are not homes, but temporary transitional places. In regard to a manufacturing place, for example, the space becomes a hemisphere that is inhabited by a craftsman for the longer portion of the day, before returning home, into privacy, and after returning, into the public of shared and only in a territorial sense owned space.

Finding the site for my artistic process is not searching something for which I have a preconceived idea of what to do in this space, which medium to use, or where to set up equipment of this sort or that, in order to showcase something that I have already created– it is rather the contrary – a not having of such a concept in mind to be able to see, and to be able to listen. Only then sets in the process of conceiving an appropriate intervention, an action that chances the site in a way that unveils it, that makes visible and audible of what is behind the walls, is kept in the air, and in the ground. My art piece becomes an inhabitant of a found site as it is reflection between this site and a spectator which is invited to intimately discover the emptiness of a space, its duration, and existence in time of something which was meant to be passage, not destination, and which takes now the shape of a sanctuary for moment that extends in time. I make my audience spend time with my pieces, as reason, and as motivation to listen, see, smell, and feel a site – in a site of such short duration that we normally just use as a passage to transfer from one spectacular or functional location to another. The sites I am inhabiting with my work are put aside; they are waiting for something to be contained into them that unveils what is surrounding. These spaces are unspectacular, they requires time to set in, they wish to be reason – they await to be rested within.

Oscillations (2004)

This process of unprepared discovery led me to the realization of 'Oscillations', as it grew out of not having a plan to work exclusively with sound at first. I was on the lookout for a spatial context into which I could reflect on a history that was presented by the space itself, as the space inhabited with the art piece would have to be the result of an intent, a function or reason for which it was crafted. The site was the U-shaped loading dock area of Building N52, now the host of studios for the Architecture Department, the Center for Advanced Visual

Studies, and the Visual Arts Program. This building was erected for the General Radio Company, producing electronic oscillation circuits. The building was still present in the architectural language of its original use, re-used, and strangely adopted with all its 1920s utilitarian appearance. I realized a sound piece between the facing, 4 story tall, flanking walls of the U-shape between which sounds created from oscillator resembling pure sine waves were bouncing back and forth.

As contents in an outside sound installment, these sounds were mixed with ambient sounds of the busy surrounding: Air conditioning units would set in with their temporal operations, loading trucks in the distance would sound their rear direction signals, traffic passing by would illustrate the hectic activities that were set on the streets.

The involuntary and unavoidable blending between intended sounds and unintended ambient sounds are an important consequence for working with sound in an outdoor public installation context. The relationship between sound installment in an architectural setting, and the context surrounding the architectural site are an important aspect in my work. My use of architectural structure as spatial context for the public use of sound is characterized by the concept of direction: present in architecture, the direction of lines that form grids as units conduct the placement of speakers as sound sources, spatial change in the sounds correspond to the spatial distribution of speakers in return. In 'Oscillations', the sounds were emulating a spatial bouncing back and forth between the two facades lining the loading dock. Visually, such bouncing between the opposing walls was almost apparent if one had thought about it. But as this was a no-space, a space left aside, inhabiting the space with sounds that supported the notion of a pulsating connection between the two sides created an event, contained a medium in between. The passage became a center, and people were encouraged to spend time within an area which previously had little to offer – in terms of where to look at and what to listen to.

In conceiving the piece, the first step was wanting to fill the space with sounds. Sounds appeared as the favorable medium in the spatial context of the loading dock, as it provided an already strong visual setting. The view just had to be directed upwards by something and using sounds as localized events immediately felt appropriate in directing gaze into the space. The U-shape of the dock instantly encouraged the installment

of a dialogue form between the two sides that channeled the corridor towards the loading ramp, across which one would enter – and exit – Building N52. This dialogue pattern encouraged the oscillation between back and forth movements: 'Oscillations' literally refers to the pendulum movement swinging back and forth, a waver. The Latin word: *oscillum*, a diminutive of *os*, "mouth", meaning "small mouth" makes reference to both, the opening and closure of the loading dock, and the 44 speakers spread over the bordering facades, as they all became mouths through which the building would speak of its past.

The spatial allocations of sounds that I had selected across the façade were representations of both, architectural structure of the building, and structural figure of the sounds, as the speakers were hung, assembled in vertical chains, from the roof. In attaching myself to something that is already there, I see myself as a responder. Sounds are coming from the building, and create localized events, as they introduce temporal change into the static setting.

Sonification of the Invisible – A large scale sound installment on the façade of the Green Building

In the case of the Green Building I knew that this was an ideal site for sonification. I use the term sonification as it is an aural equivalent to visualization, making something visible. By making the context of the Green Building audible, I allow the building to speak. Through an array of speakers mounted across its façade, the Green Building speaks to the public of research that is going on at MIT. As the Green Building houses the Earth and Planetary Sciences Department, I was looking for sound material that relates to these areas. I was inspired by sonifications in Asteroseismology, where British and Hungarian researchers had transposed light intensity changes of stars into audible signatures. In inquiring about this type of sound generation from stellar data, I made a contact with MIT's Haystack Observatory that resulted soon into a fantastic collaboration with Dr. Philip Erickson, a scientist in the area of ionospheric research, which concerns the upper layer of the earth's atmosphere.

Looking at the architectural structure of the Green Building, its accentuated grid on the south façade, I identified an interesting speaker arrangement pattern that would correspond to the

scale of the building and would reflect the geometry present behind the sounds we were creating. These sounds have a strong geometric origin, as they illustrate sonified pattern conditions of ion distributions at different altitudes in the ionosphere. Through seven layers, speaker rows are arranged upwards on the building's south façade, mapping atmospheric altitude to building altitude.

The sound samples that we obtained from the ionospheric data, collected in the course of five decades at the Haystack Observatory, show different spectral widths at different altitudes, resulting in a narrow spectrum at low altitudes and wide spectrum higher up. The width of the spectrum directs the number of speakers in each row, as the widest spectrum is subdivided into 8 bands. The lowest altitude's spectrum inhabits only two bands, while the top row of speakers utilizes all eight bands. The resulting speaker distribution pattern draws a diagonal area of 35 speakers on the façade.

In 'Sonification', sound movement is choreographed in up- and downwards direction. All speaker rows are continuously occupied as ion activity passes during a 24-hour period from higher altitudes to lower ones in a cycle. This relationship between sound structure and spatial structure of the speaker arrangement, merging visually and sonically with the found structure of the architecture illustrates my process of composing sounds specifically for the site, as the structures I embed come directly from the site. These compositions have a spatial focus. It is not my intent to create music but to work with geometry in creating spatial references.

There is a social motivation behind 'Sonification'. In allowing the Green Building to speak, I aim to make transparent of what is inside, elevated some 25 feet from the ground. Different than the older buildings on MIT's campus, the Green building's layout is scattered by the 20 independent floors, connected by narrow elevators. As with many other buildings at MIT, walking by does not provide any clue of what is going on inside. Other than the iconic radar dome on the roof, little hints towards the Earth and Planetary Sciences occupants. Little on its outside or events surrounding it relates to laboratories for planetary and earth sciences inside. The Green Building is an iconic structure. It is tall, and it has some threatening aspects. In temporarily populating its façade with an arrangement of speakers, I want to cross the barrier between ground and the untouchable façade, elevated up high, and facing the harsh winds.

This work transports interiors across exteriors. It opens up the Green Building, and it transports the remote research facility of the Haystack Observatory on campus, into the public space that the Green Building encompasses. With this sound installment, I aim to create an outcome for what is inside, in the research that is conducted here, in the building it is reflected from, and by the Observatory that collects what comes back. The sounds that are audible in front of the Green building have originated in altitudes between 100 and 700 kilometers above Massachusetts. They are made tangible in the scale of the building, directed to the human scale of the spectator. Being derived from structure, the architecture of the Green Building does not speak of content. 'Sonification' is an attempt to evoke this architecture and in working with all the groups that are concerned with the Green Building. During the evolving process of the piece, I have worked with many groups responsible for Green Building, and related to research and the building: Facilities and Safety, Haystack Observatory researchers, MIT Legal and Insurance, building inhabitants, MIT Radio Society, and NE Cleaning, the window cleaning contractor for the building.

I am not choosing architecture for its' political and social connotations. The Building is not a monument, but due to its size, it has a strong voice that has something to say. As the buildings I have previously worked with, the Green Building invites to listen closely.

*(nextpage) The Green Building,
I.M. Pei & Associates,
Cambridge, MA, 1964*



The Green Building

Building 54 was completed in 1964. It was MIT's first high-rise academic building and stood at the beginnings of re-shaping the Charles River bank's skyline - formerly dominated by domes, turrets and cupolas. The Green Building was said to eventually form a new center on MIT's campus, just as the great Dome by MIT master plan architect Welles Bosworth did in 1916.

The building is named in honor of Cecil and Ida Green, whose munificent gift of \$6 million made possible the building. Cecil Green, an MIT alumni in electrical engineering, class of 1923, was at the time of the building's dedication Honorary Chairman of the Board of Geophysical Services Incorporated of Dallas, Texas, which he had joined as a Party Chief in 1930. Mr. Green's expertise was in detecting oil reserves around the globe. As explorationist, his work has taken him and his wife several times around the globe, and he has contributed significantly to the art and science of finding oil through the combined use of geology and geophysics.

The Green Building was commissioned to house the Department of Earth and Planetary Sciences (EAPS) which owns the building to this day and offers courses in Geology, Geochemistry, Geophysics, Oceanography, and Meteorology.

The rationale for the tower design was that only by commis-

sioning a high-rise would it be possible to maintain an open space given the building square footage requirements. This open space is today marked by the dot and Alexander Calder's sail, which was implemented 1968, 4 years after the completion of the Green Building. I.M. Pei, an MIT graduate, and his partner Aldo Cossutta were respectful of the architectural tradition established by Bosworth in the original MIT layout from 1916. Building 54 would become the tallest building on campus and visible from miles away.

Bosworth's architectural language that is incorporated in the design for Building 54 is the basis of the 9-ft module, rigorous symmetry, and the areas of dark, recessed glass between the columns. These details have been replicated in concrete, which is colored and structured to resemble the appearance of the Limestone in Bosworth's original buildings.

Pietro Bellushi, Dean of Architecture during the time of the Green Building's design, construction, and opening is quoted in 'New Landmark for M.I.T.' (copy from the MIT Southampton Archives, unidentified author, presumably from 'Materials and Methods', March 1965, pp.157-163) with this statement about the design:

"It is handsome and serene, has good scale, and - most important - it looks like MIT."

The semantic coding of the Green building reflects in a sense the idea of an objective order, taken as truth - in the form of what I interpret as the neutral grid of science - although the building's look had raised eyebrows in the more scientific-oriented community among researchers and alumni of MIT, as it did not follow the traditional path of campus architecture. Aesthetic complaints had led the MIT administration to reject the Department of Meteorology proposal for the 35ft diameter radar dome in the beginning, with plans to lower other equipment of the roof, which I.M. Pei considered as 'temporary' from the beginning on. Today, the radar dome is in place, although it is no longer in use. The former launching booth for weather balloons is in use by the MIT Radio Society.

The 21 floor section of the building rests on two-story tall side pilots. This elevation emphasizes the play of gravity and massiveness, as the functional component of the building is elevated from the ground, making way for a notorious wind corridor to pass through this portal (70ft wide x 21.5ft tall), instead of streaming up the building's façade. After the completion of the

building, several problems occurred that had their origin in wind tunnel effects that swept in from the Charles River through the open plaza in front of the building's south façade.

Documented in a difficult to find article that I had tracked down in the Southampton MIT archives (Brisker, Sydney H.: With Wind Tunnels, Design is a Breeze; in: Materials and Methods, March 1967, pp. 166-171), the doors that had given entrance to the building were blocked by heavy winds and door hardware was frequently damaged by the wind effects. The current day revolving doors were a replacement these first generation doors that were blocked in the wind, making entry impossible. Michael O'Hare, a Harvard student who was completing degrees in both Architecture and Engineering conducted wind tunnel studies of a 1/130 scale model of the Green Building in 1967. He came to the conclusion that the opening in the building's ground line was responsible for the tunnel effects which cause the severe wind conditions around the entrances of the building. Wind load that would otherwise build up in the upper regions of the façade is directed downwards as it finds passage through the building.

For a while, MIT facilities had set up a temporary plywood wall that blocked one end of the arcade at the foot of the building. Then came Calder's Sail, and the sculpture is ever since breaking the notorious wind stream around the building. The building has since attracted a series of interactions. For one, its façade ranks among the prime attractions among the MIT hacking circle, the unofficial body of students responsible for placing temporary objects on Building 7's domes, with the never realized proposal to realize a game of Tetris on the Green Building's south faced, to be played from across the Charles River. Talk about a series of suicides committed in the early 1970s illuminate the dark motivation that arrest the tall building, and explain why its windows cannot be opened. Illegally entering the Green building's roof is fined a \$500.

In terms of its internal organization, the Green Building departs from Welles Bosworth's original plan for providing long corridors and non-load bearing inner walls to make space flexible for extension and adaptation. While the old buildings, in particular the infinite corridor create passage ways for social interactions, the many laboratory and offices floors on top of the lecture hall and class rooms in Building 54 separate its community. Elevators provide only narrow passage ways inbetween.

Interdepartmental contact among researchers in the Green Building has to be artificially nurtured by daily afternoon tea gatherings. (see: 'New Landmark for M.I.T.', copy from the MIT Southampton Archives, unidentified author, presumably from 'Materials and Methods', March 1965, pp.157-163).

The Green building had introduced a new building type to MIT's campus. Still almost unrivaled visually on the Cambridge side of the Charles river, it is a significant building, in particular due to the 35ft radar dome on its roof. It did fulfill expectations in becoming a landmark for MIT, its iconic building next to the domes.

*Façade details,
Green Building*

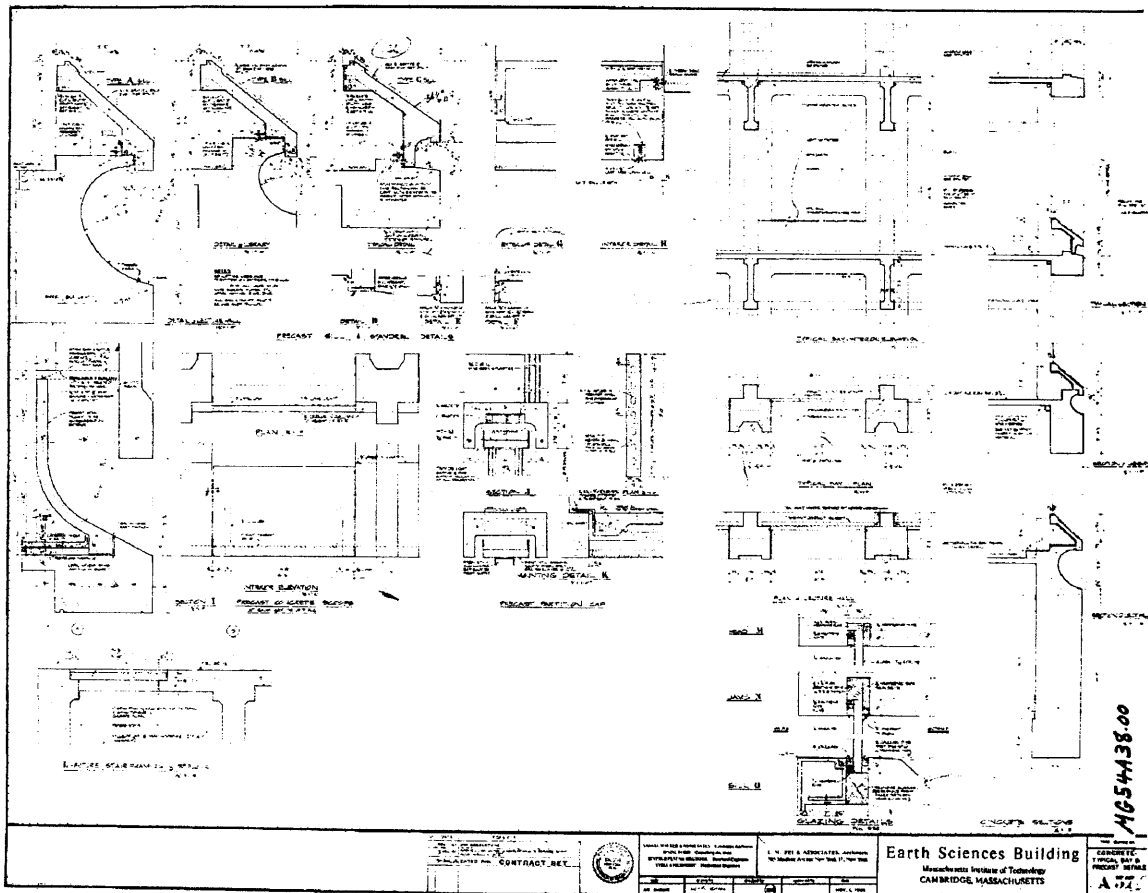

Sound as propaganda – The symbolic layer of the public address speaker – While searching for appropriate speaker designs for the proposed Green Building sound installation, electro-dynamic driven pressure horn speakers, also known as public address speakers, attracted my interest. The SPECO 20" public address speakers I have chosen are suited for outdoor use and have the desired power consumption and frequency response characteristics for the project and the sound content to be displayed. The sound of a horn speaker is very characteristic and differs from a conventional paper membrane speaker in its voluminous, spatial body, as sound is directed into all directions surrounding the speaker, while being primarily directed forward, out of the horn of the funnel. Horn speakers do not require a cabinet to produce this full-bodied sound. They are, however, limited in their frequency response. Conventional horn speakers (such as the megaphone of smaller units up to 10" diameter) have a typical, more or less linear response of 600-5000 Hz. The 20" horn that I am using has an extended range of 300-7000 Hz due to its large diameter and its intricate aluminum funnel. I had experimented with 8" electromagnetic membrane drivers in another architectural sound installation, 'Oscillations' (2004) and arrived soon at the low-end frequency limitations that these types of speakers pose without a cabinet. In oscillations, the low-end cut-off was at approximately 600 Hz. The use of large horn speakers would allow me to display lower frequencies, which work well, and are necessary to correspond in body with large open spaces.

Speco 19' horn for public address speaker, driver not attached.



The characteristic appearance of the public address speaker introduces a visual semantic context that, much like an unspoken history, goes hand in hand with the iconic appearance of the horn. Horn speakers are familiar to many of us as announcement speakers, mounted in train stations, stadiums, utilized as architectural speaker par excellence, and in the form of the megaphone as the icon of political rallies and demonstrations. The history of the public address speaker goes back to the origin of electronically transmitted sound and its political use and meaning in the darker days of politics and society.

I like to emphasize that it is not this particular history that had encouraged me to utilize the public address speaker, but it is a history that came with the found object, and one that needs to be considered, as for a second layer in my sound installation, I rely on the visual qualities of this characteristic type of speaker, mounted on the concrete grid of the Green Building as an iconic landmark – the tallest building in Cambridge.

With the invention of electric amplification and the establishment of radio broadcast came the availability of radio receivers to the public. Radio, the other side of sound, was quickly adapted by political interests who saw their advantage presented by means to reach, affect and manipulate public

opinion through the publication of the spoken word.

Public sound display had played an integral role in propaganda, utilized by the dictatorships that emerged in the twentieth century: Nazi Germany, Stalinist Russia, Communist China, and the cold war follow ups of these, Communist propaganda in the Eastern Block and South America, North Korea, and the Cultural Revolution in China. Common to all these propaganda schemes is that they display society under dictatorship as derived from technological progress, using the latest technology at the time, and displays of technological advance, architecture and defense in a self imaging campaign of grandeur, not avoiding to expand grand scales into superlatives.

An early example for audible cues that had obtained a political scale is the air raid warning siren that, during war times, had converted the audible signature of fire emergency into the haunting sound precedent of anonymous air bombing, and with it the fear of destruction out of 'nowhere' - the new phase of technological warfare introduced by WWI and fully utilized in WWII. Marinetti and his Futurist followers had elevated the noise of industrial production and the sounds of destruction in warfare as the sonic signature of progress, an ambivalence between technology and advanced society that blurred the borders between violent destruction and swift transportation.

Some of us are familiar with public address speaker announcements in the course of tornado evacuation tests, which are conducted Wednesday noon in the Midwest. Public address speakers and megaphones were and are utilized to inform the masses about emergency measures or about the prospect of forced intervention, such in the case of police presence in political protest events, in rallies, or as means to evacuate public places.

The use of public address speakers was instrumental in the electronically amplified speeches of Hitler, Mussolini, and Stalin on rallies in front of hundreds of thousands of people. Amplification, the new means to enlarge sound, was a technological necessity to make these speeches audible to the large audiences and to transmit radio signals to a far distant public. Wireless radio transmission and the electric amplification of sound became the vessel for political propaganda.

The persuasive politician became instantiated in the electric radio speaker to be present at many places simultaneously.

Opinions became disconnected from faces, and the omnipresent truth in form of speech phrasing viewpoints may have shifted into what was objectively perceived as truth.

Larger crowds made possible through electric sound amplification led to enlarged imagery of the icons of dictatorship – large scale portraits of political leaders and the insignia of party membership, often elevated over the masses on the gatherings, or attached to building façades as propaganda billboards in the city, where the visuals competed with daily business, while representing the superstitious scale of party and ideology above all things, often accompanied by sound announcements, delivering propaganda speeches or songs. Prominently in communist China or the socialist USSR, this everyday presence of party ideology created political visual and audible icons, placing required artifacts such as the public address speaker into the light of a politic instrument by itself.

Instrumental to events of this scale was, as said earlier, the availability of sound amplification and the public address speaker, as the earliest speaker capable of delivering a high decibel range within the constraints of amplification technology at the time.

Before the invention of the amplifier, marked by Lee de Forest's patent on the triode vacuum tube in 1906, the only means to amplification were the utilization of spatial forms to mechanically amplify sound pressure waves carried through air by inducing resonance in structures like horns, instrument bodies or concert halls – the same principle is utilized in the public address speakers that I utilize in my sound installment.

The amplification of music to high sound levels remained a technological challenge up until the late sixties, when with the arrival of the transistor (invented 1947 at Bell labs by John Bardeen, Walter Brattain, and William Shockley) an alternative to older valve based amplifier designs was available. The new amplifier designs were capable to deliver higher current to electro-dynamic membrane drivers, which were capable to produce lower frequencies required for the high fidelity music frequency spectrum. The Woodstock Festival of 1969 illustrates some of the new capabilities of sound reproduction in front of a huge crowd, along with the audible limitations in fidelity at the time.

Chapter 3

In progress

In preparing for the realization of the sound piece for the Green Building the project was shown in progress for the Visual Arts Program Open House May 13-15 2005. This was a preliminary presentation of the work which signified important aspects of the project: 35 speaker formation on the ground as would be on the building and sounds distributed and played as they would be for the final realization. The speaker placement on the ground spanning a large courtyard area allowed for an interesting response to the speakers 'speaking' to the sky: speaking to their source, the ionosphere.



Room 14-0551
77 Massachusetts Avenue
Cambridge, MA 02139
Ph: 617.253.2800
Email: docs@mit.edu
<http://libraries.mit.edu/docs>

DISCLAIMER OF QUALITY

Due to the condition of the original material, there are unavoidable flaws in this reproduction. We have made every effort possible to provide you with the best copy available. If you are dissatisfied with this product and find it unusable, please contact Document Services as soon as possible.

Thank you.

Pagination error by the author. Pages 50 - 52 do not exist.

*'Sonification: In Progress', ground
speaker arrangement, May 13,
2005, Visual Arts Program Open
House*





Carrie Bodle Thesis Review May 13, 2005:



pictured left to right: Dr. Philip Erickson, Carrie Bodle, Krzysztof Wodiczko



pictured left to right: Dr. Philip Erickson, Carrie Bodle, Allan McCollum, Axel Roesle



pictured left to right: Dr. Philip Erickson, Carrie Bodle





*'Sonification: In Progress', ground
speaker arrangement, May 13,
2005, Visual Arts Program Open
House*

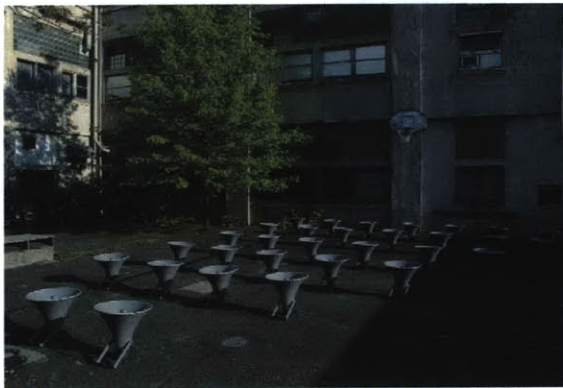



Bibliography

Barthes, Roland. The Grain of the Voice. In *On Record: Rock, Pop, and the Written Word*. Edited by Simon Frith and Andrew Goodwin. London and New York: Routledge, 1990, 293-300

Cage, John. *The Future of Music: Credo*. In *Silence: Lectures and Writings by John Cage*. Hanover, NH: University Press of New England/Wesleyan University Press, 1961

Handel, Stephen. *Listening: An Introduction to the Perception of Auditory Events*. Cambridge, MA and London: The MIT Press, 1993

Kahn, Douglas. *Noise, Water, Meat: A History of Sound in the Arts*. Cambridge, MA and London: The MIT Press, 1999

'New Landmark for M.I.T.' (copy from the MIT Archives, unidentified author, presumably from *Materials and Methods*, March 1965, pp.157-163)

Russolo, Luigi. *The Art of Noises (extracts) 1913*. In *Futurist Manifestos*. Edited with an introduction by Umbro Appolonio. London: Thames and Hudson, 1973

Schaeffer, Pierre. *Acousticmatics*. In *Traité des objets musicaux*. Translated for this volume by Daniel W. Smith. Paris: Éditions du Seuil, 1966

Schafer, R. Murry. *The Music of the Environment*, Vienna: Universal Edition, 1973

Site of Sound: Architecture and the Ear. Edited by Brandon Labelle and Steve Roden. Los Angeles: Errant Bodies Press, 1999

Varese, Edgard. *The Liberation of Sound*. In *Contemporary Composers on Contemporary Music (expanded edition)*. Edited by Elliot Schwartz and Barney Childs. New York: Da Capo Press, 1998, 195-208

Consulted websites:

Resoundngs.org, Homepage of Bill Fontana
<http://www.resoundings.org/>

Photo credits

p.18 Reprinted from
<http://www.haystack.mit.edu>

p. 30 Reprinted from
http://www.americaslibrary.gov/cgi-bin/page.cgi/aa/scientists/edison/phonograph_1
(Photo courtesy of U. S. Department of Interior, National Park Service, Edison National Historic Site.)

p. 31 Reprinted from
<http://history.acusd.edu/gen/recording/tape.html>

p. 32 Reprinted from
<http://www.cultureguide.gr/images/events/files/PhilipsPavillion.jpg>

p. 54 Photos courtesy of Joe Gibbons

Other photos by Carrie Bodle