

Platforms and Real Options in Large-Scale Engineering Systems

by

Konstantinos Kalligeros

Dipl. Civil Engineering, National Technical University Athens, 2000

M.S., Massachusetts Institute of Technology, 2002

Submitted to the Engineering Systems Division

in partial fulfillment of the requirements for the degree of

Doctor of Philosophy

at the

MASSACHUSETTS INSTITUTE OF TECHNOLOGY

June 2006

© Konstantinos Kalligeros, MMVI. All rights reserved.

The author hereby grants to MIT permission to reproduce and distribute publicly paper and electronic copies of this thesis document in whole or in part, and to grant others the right to do so.

BARKER

Author

~~Engineering Systems Division~~

June 2006

Certified by

~~Richard de Neufville
Professor, Engineering Systems Division
Thesis Supervisor~~

Certified by

Olivier de Weck
Assistant Professor, Aeronautics & Astronautics and Engineering Systems

Certified by

David Geltner
Director, Center for Real Estate,
Professor of Real Estate Finance, Department of Urban Studies & Planning

Certified by

~~Patrick Jaillet
Department Head & Edmund K. Turner Professor,
Department of Civil and Environmental Engineering~~

Accepted by

~~Richard de Neufville
Chairman, Engineering Systems Division Education Committee~~

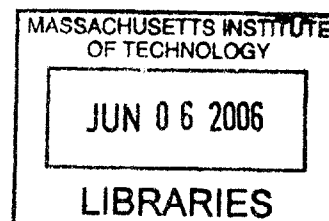

Platforms and Real Options in Large-Scale Engineering Systems

by

Konstantinos Kalligeros

Submitted to the Engineering Systems Division
on June 2006, in partial fulfillment of the
requirements for the degree of
Doctor of Philosophy

Abstract

This thesis introduces a framework and two methodologies that enable engineering management teams to assess the value of real options in programs of large-scale, partially standardized systems implemented a few times over the medium term. This enables value creation through the balanced and complementary use of two seemingly competing design paradigms, i.e., standardization and design for flexibility.

The flexibility of a platform program is modeled as the developer's ability to choose the optimal extent of standardization between multiple projects at the time later projects are designed, depending on how uncertainty unfolds. Along the lines of previous work, this thesis uses a two-step methodology for valuing this flexibility: screening of efficient standardization strategies for future developments in a program of projects; and valuing the flexibility to develop one of these alternatives.

The criterion for screening alternative future standardization strategies is the maximization of measurable standardization effects that do not depend on future uncertainties. A novel methodology and algorithm, called "Invariant Design Rules" (IDR), is developed for the exploration of alternative standardization opportunities, i.e., collections of components that can be standardized among systems with different functional requirements.

A novel valuation process is introduced to value the developer's real options to choose among these strategies later. The methodology is designed to overcome some presumed contributors to the limited appeal of real options theory in engineering. Firstly, a graphical language is introduced to communicate and map engineering decisions to real option structures and equations. These equations are then solved using a generalized, simulation-based methodology that uses real-world probability dynamics and invokes equilibrium, rather than no-arbitrage arguments for options pricing.

The intellectual and practical value of this thesis lies in operationalizing the identification and valuation of real options that can be created through standardization in programs of large-scale systems. This work extends the platform design literature with IDR, a semi-quantitative tool for identifying standardization opportunities and platforms among variants with different functional requirements. The real options literature is extended with a methodology for mapping design and development decisions to structures of real options, and a simulation-based valuation algorithm designed to be close to current engineering practice and correct from an economics perspective in certain cases. The application of these methodologies is illustrated in the preliminary design of a program of multi-billion dollar floating production, storage and offloading (FPSO) vessels.

Thesis Supervisor: Richard de Neufville

Title: Professor, Engineering Systems Division

Olivier de Weck

Title: Assistant Professor, Aeronautics & Astronautics and Engineering Systems

David Geltner

Title: Director, Center for Real Estate,

Professor of Real Estate Finance, Department of Urban Studies & Planning

Patrick Jaillet

Title: Department Head & Edmund K. Turner Professor,

Department of Civil and Environmental Engineering

to the “children:”

Johnny,

Kassandra,

Anna,

Irene,

Anastasia,

Ina and of course,

Konstantinos!

Acknowledgments

My deepest gratitude goes to my parents, *Chryssanthos and Eirini*, and my brother, *Johnny*, for the drive, love, unconditional support, and “good vibes” this effort required!

I ought to thank my advisor, *Richard de Neufville*, for steering me through and pushing me further than I thought I could go; *Olivier de Weck*, for his creative ideas, his care and for being the catalyst that got the final stages of this thesis going; *David Geltner*, for his contagious open-mindedness, sharpness and enthusiasm; *Patrick Jaillet* for his observations and suggestions that solidified some concepts in this thesis and broadened its audience.

I am deeply grateful to everyone who happened, or brought themselves to be at the right place at the right time over these years: *Yiannis Anagnostakis*, *Yiannis Bertsatos Alexandros*, *Lydia*, *Lenka* and *Susan*. You have been the balancing factor during some very unbalanced years. My very special thanks to *Iason* and *Andrea*, who saw me through. Beth and Timea, you made a dull office, interesting and fun—thank you! I am also deeply thankful to my family in the US, who have taken care of me since my first day here: *George*, *Margaret*, *Leo* and *Alexis Carayannopoulos*, and *George*, *Jasmin*, *Maria* and *Eleni Lampadariou*.

Finally, many thanks to the sponsors of this work, who have provided insights, thoughts, their experience and relevant data, particularly *Adrian Luckins* from BP and *John Dahlgren* and *Michele Steinbach* from MITRE.

Contents

1	Introduction	19
1.1	Motivation	19
1.2	Platforms in consumer products and engineering systems	19
1.3	Design for flexibility	21
1.4	Platforms and flexibility	23
1.5	Bridging the gap: thesis	24
1.5.1	Approach	24
1.5.2	Contributions	25
1.6	Thesis outline	26
2	Literature Review	27
2.1	Introduction	27
2.2	Product platforms and families	28
2.3	Platform and standardization benefits	30
2.3.1	Learning curve effects	30
2.3.2	Maintenance, Repair and operations benefits	32
2.4	Platform selection and evaluation	34
2.4.1	Optimized search for platform strategies	36
2.4.2	Heuristic identification of platform strategies	36
2.4.3	Product platform evaluation and design	37
2.5	Strategic view of platforms	39
2.6	Flexibility and real options	42
2.6.1	Flexibility and real options in engineering projects	45
2.6.2	Option valuation	47
2.7	Summary and research contribution	53
3	Invariant Design Rules for platform identification	55
3.1	Introduction	55
3.2	Related work	56
3.2.1	The design structure matrix (DSM)	57
3.3	Platform identification at the design variable level	60

3.3.1	sDSM system representation	60
3.3.2	Change propagation	61
3.3.3	Platform identification	62
3.3.4	Algorithm for platform identification	64
3.4	Platform identification at higher system levels	66
3.4.1	Activity SDSM representation	66
3.4.2	Exogenous parameters and change propagation	69
3.5	Exploration of platform strategies	70
3.5.1	Change absorbers and platform strategies	71
3.6	Multi-level platforms	74
3.7	Summary	76
4	Flexibility valuation in large-scale engineering programs	79
4.1	Introduction	79
4.2	Design and development decisions	81
4.2.1	Assets and states	82
4.2.2	Decisions on timing	84
4.2.3	Decisions on target state	86
4.2.4	Complex design and development structures	87
4.3	Valuation	88
4.3.1	Calculation of conditional expectations	91
4.3.2	Valuation of a reference design	92
4.3.3	Valuation of two perfectly correlated states	93
4.3.4	Valuation of timing options	95
4.3.5	Valuation of choice options	96
4.4	Methodology performance and discussion	96
4.4.1	Design decisions modeling	97
4.4.2	Algorithm Performance	97
4.4.3	Valuation of uncorrelated states	98
4.5	Summary	103
5	FPSO program design study	105
5.1	Introduction	105
5.1.1	FPSO process technology description	107
5.1.2	FPSO program design case: problem statement and approach	108
5.2	Standardization effects	114
5.2.1	Reduction in operating expenses	115
5.2.2	Reduction in FEED cost and time	118
5.2.3	Reduction in construction cost	121
5.2.4	Reduction in construction time	122

5.3	Screening of platform strategies	126
5.3.1	The low-hanging fruit	126
5.3.2	Compromise strategies	126
5.4	Valuation of standardization program	129
5.4.1	Valuation results	132
5.5	Summary	134
6	Conclusions and future work	137
6.1	Summary	137
6.2	Future research	138
6.2.1	Flexibility-based optimization and value created	139
6.2.2	IDR-based platform optimization	139
6.2.3	Application: trading-off commitment and flexibility	140

List of Figures

1-1	2-stage methodology for flexibility and platform design	24
2-1	Platform utilization among major automotive manufacturers	29
2-2	85% learning curve	32
2-3	Estimated inventory level savings due to standardization and demand pooling	35
2-4	Two-step process for designing platform variants	38
2-5	Design for variety: spatial and temporal evolution of product families . . .	39
2-6	Flexibility in engineering, manufacturing and operations	46
2-7	Two steps of a recombining binomial lattice of s	48
2-8	Bin definition and transition probabilities in SSAP algorithm	52
3-1	DSM configurations that characterize physical links or information flows . .	58
3-2	Original and clustered DSM	58
3-3	Normalized SDSM, extended to include exogenous functional requirements .	61
3-4	Invariant Design Rules on an S-DSM	64
3-5	Clustering of a 45-variable DSM into 6 systems	67
3-6	DSM representation of design activities at a system level	68
3-7	System-level DSM, extended to include functional requirements	70
3-8	Invariant design rules for system-level DSM, given changes in FR1	71
3-9	Effect of removing the sensitivity of B to FR1 and F	72
3-10	Effect of removing the sensitivity of A to B	72
3-11	Effect of removing the sensitivity of systems F and B to FR1	73
3-12	Removing SDSM entries: simulation results	74
3-13	Decomposition of system A at the variable level	75
3-14	Decomposition of system A at the subsystem level	76
3-15	Re-partitioned SDSM, with platform that includes subsystem-level line items	76
4-1	An American timing option to obtain state w from state u : transition can occur at any time within a time horizon.	85
4-2	A European option to obtain state w from state u : transition can occur only at a specific time.	85
4-3	An American option with time-to-build t_{tb}	86

4-4	Choice between development options to 4- and 5-level garage	87
4-5	A complex structure of development decisions	88
4-6	Characterization of the proposed option valuation methodology (shaded boxes) and comparison with other valuation approaches.	90
4-7	Two-dimensional bin definition and some representative values at time t	91
4-8	Inferred price of risk from reference design valuation	93
4-9	Risk and discount rate for design w	94
4-10	American call option: Valuation errors	99
4-11	American call option: Valuation errors	100
4-12	American call option: Valuation errors	101
4-13	American call option: Valuation errors	102
5-1	Greater Plutonio FPSO offshore Angola (operated by BP)	106
5-2	Main topsides facilities functions and equipment (simplified)	108
5-3	Comparison between assumed functional requirements of FPSOs α and β	111
5-4	FPSOs α and β program development decisions	113
5-5	Effects of system standardization between FPSOs α and β	115
5-6	Assumed percent breakdown of development costs by system, FPSO α	116
5-7	FEED cost and time as a function of standardization by weight	119
5-8	Assumed learning curves in FPSO construction costs	122
5-9	FPSO α construction schedule. All links are start-to-start with lag.	125
5-10	Original SDSM for FPSO α	127
5-11	Partitioned SDSM for FPSO α , showing standardized systems according to strategy 0 (no entries removed).	127
5-12	Pareto-optimal strategies	129
5-13	FPSOs α and β program development decisions	130

List of Tables

31

3.1	DSM types, applications and analysis techniques	59
3.2	Algorithm for the partitioning of standardized DSM items	65
5.1	Main FPSO process systems and utilities	109
5.2	Assumed functional requirements for FPSO α and β	110
5.3	Assumed FPSO annual spare part costs for each system (\$1,000)	117
5.4	Assumed FPSO FEED costs for each system (\$1,000)	120
5.5	Assumed FPSO α construction costs for each system (\$1,000)	123
5.6	Assumed FPSO β construction costs for each system (\$1,000)	124
5.7	Measurable standardization effects: $g(\%)$ functions for $\beta_1 \dots \beta_{16}$	130
5.8	Standardization strategies	131
5.9	Estimated costs for 5 selected standardization programs (based on current prices of oil, gas and steel).	132
5.10	Value of states $\alpha\beta_i$	133
5.11	Value of construction options for states $\alpha\beta_i$	133
5.12	Option to design and develop states $\alpha\beta_i$	134

Nomenclature

$a_t(m)$	Total number of paths falling in bin m at time t
$b_t(m, n)$	Total number of paths falling in bin m at time t and bin n at $t + \delta t$
c	The opportunity FEED cost of standardization, i.e., the cost difference between a fully customized and a fully standardized design, over the difference in FEED time.
c'	The opportunity construction design cost of standardization, i.e., the cost difference between a fully customized and a fully standardized design, over the difference in detailed design time.
$C_{\alpha\beta}$	Time-to-build FPSO β , given that FPSO α is already built
C_{β_0}	Time-to-build a completely customized FPSO β_0
C_{uw}	“Construction” cost for obtaining state w from state u
CAP_{α}^{gas}	Oil production capacity of FPSO α (mbod)
CAP_{α}^{oil}	Gas production capacity of FPSO α (mmscfd)
$CEQ[\cdot]$	The certainty-equivalent of a quantity, i.e., the expected quantity reduced by a dollar risk premium and then discounted at the risk free rate.
$CF(\mathbf{x}^{\alpha}, \mathbf{s}_t)$	$\equiv CF_{\alpha}(\mathbf{s}_t)$ The cash flows that would be generated by FPSO α individually (in the absence of FPSO β) per time period, given state of uncertain factors \mathbf{s}_t
$CF_{\alpha}^{fix}(\mathbf{s})$	Fixed production costs for FPSO α
$CF_{\alpha}^{var}(\mathbf{s})$	Variable production costs for FPSO α
$CF_{\alpha\beta}(\mathbf{s}_t)$	The cash flow generated by the simultaneous operation of FPSOs α and β per time period, given state of uncertain factors \mathbf{s}_t
$D_{\alpha\beta}$	Ch.5: cost to design FPSO β , given that FPSO α is already designed and constructed
D_{β_0}	Ch.5: cost to design an entirely customized FPSO β_0
D_{uw}	“Design” cost for obtaining timing option to state w from state u
F_{uw}	Value of timing option to obtain state w in exchange of state u
FR	Vector of functional requirements
$g_1(\mathbf{x}^{\alpha}, \mathbf{x}^{\beta})$	% reduction in fixed production costs for simultaneous operation of FPSOs α and β

$g_2(\mathbf{x}^\alpha, \mathbf{x}^\beta)$	% reduction in front-end-engineering design (FEED) cost of FPSO β , given that FPSO α is already designed
$g_3(\mathbf{x}^\alpha, \mathbf{x}^\beta)$	% reduction in front-end-engineering design (FEED) time of FPSO β , given that FPSO α is already designed
$g_4(\mathbf{x}^\alpha, \mathbf{x}^\beta)$	% reduction in construction and fabrication cost of FPSO β , given that FPSO α is already constructed
$g_5(\mathbf{x}^\alpha, \mathbf{x}^\beta)$	% reduction in construction and fabrication schedule time of FPSO β , given that FPSO α is already constructed
h	Index for alternative underlying assets (choices) in a choice option. E.g., corresponds to alternative FPSO designs $\beta_1 \dots \beta_h$ in Ch. 5.
H_{uw}	The holding value of an option to obtain w by giving up u
I_{uw}	Value of immediate exercise of an option to obtain w by giving up u
j	Ch. 3: index Ch. 4: indicator for time period
J	Ch. 3: Jacobian matrix Ch. 4: Total number of time instances in a simulation (including $t = 0$)
k	Ch. 3: step in IDR algorithm Ch. 4: indicator for a simulation event (path)
K	Total number of simulation events (paths)
M	Total number of bins per time period in a simulation
m, n	Indices for bins, m typically corresponding to time t and n to time $t + \delta t$
mbd	Thousand Barrels per Day, common unit in oil production
mbod	Thousand Barrels of Oil per Day, common unit in oil production
mmscf	Million Standard Cubic Feet, common unit of gas volume in oil production
mmscfd	Million Standard Cubic Feet per Day, common unit of gas productivity in oil production
N	Total number of sources of uncertainty in a simulation
$p, 1 - p$	Real-world probabilities
$P_t(m, n)$	m, n element of transition probability matrix at time t , real-world dynamics
$q, 1 - q$	Risk-neutral probabilities
r_f	Continuously-compounded risk-free rate
r_u	Continuously-compounded rate, risk adjusted to appropriately discount expected values of state or option u
RP_α	Risk premium demanded by investors holding asset α
\mathbf{s}_t	Value of vector of uncertain factors at time t
$\bar{\mathbf{s}}_t^m$	representative value of vector of uncertainties at time t in bin m

s_d	Ch. 2: in a binomial lattice, the “down” value of the underlying asset one period in the future
s_t^{gas}	Spot price of oil (\$/bbl) at time t
s_t^{oil}	Spot price of gas (\$/mscf) at time t
s_t^{steel}	Spot price of steel (\$/ton) at time t
s_u	Ch. 2: in a binomial lattice, the “up” value of the underlying asset one period in the future
t	Time
T	Time, generally used to denote terminal time, time of option expiration, or the time horizon
$T_{\beta\alpha}^{DD}$	Detailed (construction) design time required for an FPSO β partially standardized based on FPSO α
$T_{\beta_0}^{DD}$	Detailed (construction) design time required for a fully customized FPSO β_0
TtB_i	Time-to-build asset i , the time lag between the decision to exercise an option and obtaining the asset
TtD_i	Time-to-design asset i , the time lag between the decision to exercise a choice option and obtaining the asset or the corresponding construction option
$TtD_{\alpha\beta}$	Time-to-design FPSO β , given that FPSO α is already designed
TtD_{β_0}	Time-to-design a completely customized FPSO β_0
\mathbf{x}	Vector of design variables (or system line items) in SDSM
\mathbf{x}^*	Vector of design variables (or system line items) of variant $*$
\mathbf{x}^α	Vector of design variables (or system line items) of variant α
\mathbf{x}_c^α	Subset of the design vector of variant α that is unique to that variant
\mathbf{x}_p	Subset of the design vector that is equal for two variants and constitutes the platform between them
$V_{3b}(\alpha_1)$	Ch. 5: it is the value, calculated using approach 3b, of an FPSO α that has been optimized using approach 1 (see page 109).
V_u	Total value of state u , including the value of any associated options
V_u^{cf}	Intrinsic value of state u , i.e., the discounted expected value of future cash flows
α	Ch. 3: the name of one system variant; Ch. 5: the name of the first FPSO in a development program
$\alpha\beta_1 \dots \alpha\beta_{68}$	Names of the states of simultaneous operation of FPSOs α and β_1 to β_{68} respectively.
β_0	The name of a fully customized FPSO β
$\beta_1 \dots \beta_{68}$	Ch. 3: names of system variants;

	Ch. 4: the name of the second FPSO in a development program
$\Delta C(\mathbf{x}^\alpha, \mathbf{x}^\beta)$	The construction and fabrication cost difference between customizing all systems in FPSO β , minus the (reduced) cost of re-using the designs from FPSO α .
$\Delta D(\mathbf{x}^\alpha, \mathbf{x}^\beta)$	The FEED cost difference between customizing all systems in FPSO β , minus the (reduced) cost of re-using the designs from FPSO α .
δt	Time increment used for computations
κ	Number of line items (design variables or systems) in SDSM
λ	Price of risk
ξ	Number of external functional requirements in SDSM
Π_k	Running subset of SDSM line items in iteration k of the IDR algorithm

Chapter 1

Introduction

1.1 Motivation

The work in this thesis is motivated by a gap between two seemingly competing but related concepts in the academic literature and practice. The first is *platform design*, especially for large-scale engineering systems. The second is *design for flexibility*, an emerging trend in practice and a hot topic of academic research over the past years. Based on intuition alone, design for flexibility and platform design seem competing paradigms: a platform is, after all, a set of standardized components, processes, technology etc. among a family of products, that is usually expensive to design and develop, and constrains the development of new products and the marginal improvement of existing ones. The counter-argument is that platforms enable the development of (possibly very different) variants at low cost; in this sense, a platform is a *springboard* for entering markets for new products or expanding existing product families: it is almost *synonymous* with having flexibility to introduce more new products, faster! Apparently, there is no intuitive and conclusive answer as to whether design for flexibility and platform design are competing paradigms.

In fact, the hypothesis for this work is that platform design creates and destroys future flexibility at the same time and in different ways. The two paradigms can be competing in some ways and complementary in others. Therefore, there is a need for a structured process for concurrent platform design and flexibility design. This need is driven by the high potential value of both platforms and flexibility. For many systems the stakes are not trivial, as shown by direct data as well as industry trends.

1.2 Platforms in consumer products and engineering systems

A quick look into the firms that lead their industry sector reveals that they have moved from producing a single product in large quantities, to differentiating the performance characteristics of their product range. Such trends were seen in consumer products, such as walkmans and electric appliances, as well high-technology complex systems such as com-

mercial aircraft. The shift in the design paradigm from one-at-a-time designs to “mass customization” (i.e., very different products variants that share a common platform) has enabled organizations to tap into economies of scale, knowledge sharing, easier development of a larger number of variants, maintenance benefits and spare part reduction (enjoyed by both manufacturers and users of product variants).

Examples are abundant. In the 1980s, Sony based hundreds of variants of the the Walkman on just three platforms for the mechanical and electronic parts of the product (Sanderson 1995). Also maintaining “hidden” components similar, Black and Decker built a line of products with various power requirements based on a single scalable electric drive (Meyer & Lehnerd 1997). At the same time, Airbus was able to differentiate significantly in the performance characteristics of a series of aircraft (particularly A318, A319, A320 and A321), while retaining the same “look and feel” in the cockpit, thereby reducing crew training time and creating value for its clients. This way, Airbus extended the concept of platforms beyond the common design of physical components. Platforms can also imply common intangible characteristics that add value to a family of products.

Even oil companies have been unlikely followers of the platform design paradigm. For example, some recent programs of oil development projects have been developed according to a *complete standardization* strategy. Exxon/Mobil’s Kizomba A and Kizomba B platforms offshore Angola are built almost entirely on the same identical design. BP’s development in the Caspian Sea offshore Baku, Azerbaijan, consisted of 6 almost identical semi-submersible rigs. The three trains at BP’s Atlantic Liquefied Natural Gas (LNG) plant were designed identically and constructed sequentially.

In consumer products, the platform design paradigm is ubiquitous because of clear and well-documented benefits. Given a high volume (or expected volume) of production of a product family, developers expected to share the learning curve for the design and manufacturing of platform components among all variants. The cost of redesigning platform components for every variant is also avoided, thereby leveraging capital expenses of producing variants and the initial platform. Significant benefits are also experienced in the form of strategic supplier agreements and alliances, resulting in fast and reliable supply chains. Overall, platform design has enabled product families with very similar functional characteristics to suit customers’ needs exactly, thereby expanding and re-inventing markets, and giving developers competitive advantage.

Platform benefits are also documented in the development of large-scale systems, e.g., oil exploration and production infrastructure (McGill & de Neufville 2005). Standardization of components and processes in such projects has resulted in double-digit percentage reductions in capital costs, cycle time, operability and maintainability. Besides leveraging direct and indirect engineering costs, repeated upstream developments have shown learning curves and savings in fabrication costs. Repeated supplier agreements and larger material orders have contributed to lower contract costs and less risky contract deliveries. The re-use of identical systems and components across projects and the common design philosophy overall, has

resulted in lower spares inventories, personnel training expenses and operational process design. Finally, the approach has resulted in better utilization of scarce engineering and management personnel capable of projects of such scale. Being committed to utilizing local human resources, oil companies re-using designs and implementing platforms have also experienced a steep learning curve in local capability. Seemingly, platform benefits are directly transferrable to large-scale systems.

The next intellectual challenge for platform strategists and academics lies in the design, development and utilization of platforms in time, in a dynamic setting of changing customer preferences, cost line items, product value and evolving technology. A platform strategy, i.e., the selection and extent of platform components, must not only satisfy static or deterministically changing criteria of optimality; it must enable the evolution and adaptation of the entire organization to changing conditions as the future unfolds. Fricke & Schultz (2005) report the main challenges with implementing platform strategies and architectures:

- The incorporation of elements in system architectures that enable them to be changed easily and rapidly.
- The intelligent incorporation of the ability to be insensitive or adaptable towards changing environments.

1.3 Design for flexibility

What Fricke & Schultz (2005) call the next challenge in platform design is that it incorporates flexibility. It can be argued that flexibility is not just an opportunity for added value or a welcome side-effect of a good design; in a competitive environment, it is a design requirement. In the words of Kulatilaka (1994),

A myopic policy does not necessarily fail; it fails insofar as uncertainty represents opportunity in a competitive environment.

For example, de Weck, et al. (2003) point out that much of the financial failure of both communication satellite networks built in the mid-nineties, Iridium and Globalstar, could have been avoided if the systems were designed to be deployed in stages, thereby retaining the programmatic flexibility to change the scale of the project, its configuration and data transmitting capacity before its completion¹. In real estate, volatile markets have also given rise to flexible development. Archambeault (2002) reports the rapid decline in value

¹Iridium and Globalstar were two similar, competing systems of satellite mobile telephony. During the time between their conception, licencing, design and deployment, a total of about 8 years, GSM networks, a competing terrestrial technology, had come to dominate many of the core markets these systems were targeting. Despite the enormous technical success of these systems, both companies filed for bankruptcy protection with losses between \$3-5bn each. At this time, the two satellite networks operate significantly under capacity with clients such as the US government, exploiting their technical niche of global coverage that terrestrial cellular networks cannot provide.

for telecommunications hotels after the dot-com market crash at the turn of the century². With the dot-com market crash, the vacancy rate of these buildings increased steeply and their owners started to look into their reconfiguration capability. Those buildings that were designed to cheaply convert to laboratory or office space did so at low costs; others had to be drastically re-designed. Similar cases in real estate can be found in Greden & Glicksman (2004).

Despite the strong case for considering flexibility in design, most engineering managers still focus on “point designs.” Cullimore (2001) summarizes the current “point-design” engineering paradigm, and contrasts it with an approach that accounts for uncertainty and flexibility:

Point designs represent not what an engineer needs to accomplish, but rather what is convenient to solve numerically assuming inputs are known precisely. Specifically, point design evaluation is merely a subprocess of what an engineer must do to produce a useful and efficient design. Sizing, selecting, and locating components and coping with uncertainties and variations are the real tasks. Point design simulations alone cannot produce effective designs, they can only verify deterministic instances of them.

Wang & de Neufville (2005), Wang (2005) and de Neufville (2003) built on the concept and theory of *real options* to distinguish between managerial flexibility that is emergent or coincidental in the development and operation of a system, and flexibility that has to be anticipated, designed and engineered into systems. They call the former, “real options ‘on’ projects” and the latter, “real options ‘in’ projects.” Several academic papers have explored case studies of options “in” projects: de Weck et al. (2003) suggested alternative programmatic and technical design for the Iridium and Globalstar systems so that flexibility was created through staged deployment; Kalligeros & de Weck (2004) explored the optimal modularization of an office building that would be required to contract and change use in the future; Wang (2005) used mixed-integer stochastic programming to value path-dependent options in river basin development; Markish & Willcox (2003) explore the coupling between technical design and programmatic decisions as they provide flexibility in the deployment of a new family of aircraft; Zhao & Tseng (2003) investigate the flexible design of a simple building, a parking garage with enhanced foundations and columns, that can be expanded to cover local parking demand.

However, flexibility design and real options “in” systems are still very far from becoming current practice. Despite the appeal that these case studies have to their respective engineering audiences, neither the concept nor the methodology has so far had a significant

²Telecommunications hotels are buildings specially configured to host electronic equipment (servers, storage etc.), servicing the computational needs of internet companies. The design requirements for such buildings are very different from residential or office construction: ceilings can be low, HVAC requirements are stringent, natural light is avoided, and there is very little need for parking.

impact in the way systems are designed and developed. We can begin to postulate about the reasons this is so:

- The examples in the academic literature can often be perceived to be contrived, unrealistic and over-simplified in order to facilitate analysis. This way they lose potential for real impact and fuel practitioners' resistance.
- The organizational and incentive structure between the entities that conceive, design, sanction, finance and execute projects is often such that the involved teams are not inclined to pursue the creation of flexible systems. This is often because the costs of engineering flexibility must be justified internally by teams different than the ones that are attributed the added value. As a result, the research efforts of academics have no audience in the industry, to own and promote new results.
- Even if the incentive and will to design flexibility in engineering systems exists, there is no technical guidance as to how. In other words, there is a lack of an unambiguous language for modeling design and development decisions as real options.
- Currently, real option valuation technology relies too heavily on its financial option valuation counterpart. As a result, both concept and practice appear restrictive, counter-intuitive and difficult to understand by engineering practitioners in the cultural context of real organizations.

1.4 Platforms and flexibility

On one hand, platform design and standardization appears to be a great source of value. On the other, flexible design was demonstrated to be almost a necessity in an uncertain competitive environment. To what extent are these paradigms competing and how might they be complementary, especially for the development of large-scale systems?

They can be complementary because standardization can increase strategic flexibility by enabling the developer to design and construct faster and more reliable systems, use existing expertise to enter new ventures and markets cheaply, or even exit projects retaining high salvage value (because systems and components can be used in other projects). As such, platforms are equivalent to "springboards," bringing the organization closer to new ventures. Platforms are also the source of operational flexibility, because they enable the inter-changeability of components and modules. This is ubiquitous, e.g., in personal computers and electronics with standardized interfaces.

However, platform design can be detrimental to strategic flexibility, especially in the long run. Extensive standardization can be blamed for (risky) locking-in with suppliers and technology, limiting innovation and creativity within the organization. An equally real risk concerns the extensive design of inflexible platforms that cannot accommodate changing future requirements.

It is evident that optimal standardization decisions must include flexibility considerations, and conversely, that flexible designs can be implemented through component and process standardization when multiple instances or variants of a system are involved. The evaluation of programs of large-scale systems with considerations for platforms and flexibility is a new paradigm in system design.

1.5 Bridging the gap: thesis

This thesis introduces a framework and two methodologies that enable engineering management teams to assess the value of flexibility in programs of large-scale, partially standardized systems implemented a few times over the medium term.

1.5.1 Approach

The proposed framework is presented in the context of a development program with two phases, i.e., two assets designed and constructed sequentially. These can be partially based on the same platform, i.e., share the design of some of their components and systems. It is assumed that the decision to standardize certain components between the two systems is taken at the time the *second* asset is designed, and that different standardization strategies (i.e., selection of common components) will be followed depending on information about the state of the world at that time. The value of the program at the first stage includes the value of flexibility to optimally design and develop the second development, based on the “design standard” or platform established with the first.

This work provides a two-step methodology for valuing the first-stage design, as shown in Figure 1-1. The first step involves screening alternative standardization strategies for the second development. The second step involves valuing the flexibility to choose among these standardization strategies for the second-phase development. This flexibility is associated with the first-phase system and is an intrinsic part of its value.

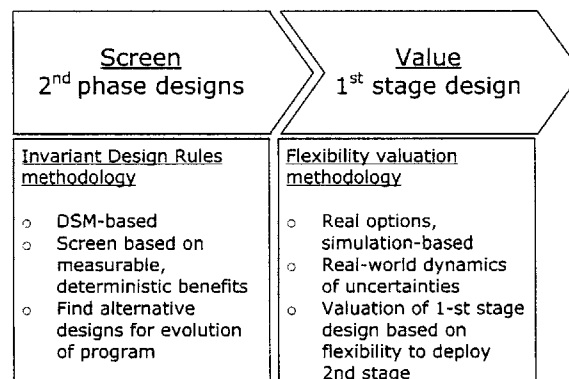

Figure 1-1: 2-stage methodology for flexibility and platform design

Screening of standardization opportunities is based on a novel methodology and algorithm for locating collections of components that can be standardized among system variants, given their different functional requirements. The criterion for screening alternative future standardization strategies is the maximization of measurable standardization effects that do not depend on future uncertainties. Examples of such criteria may be *reduction in structural weight* or *construction time reduction* for later projects. Using multi-disciplinary engineering judgment and simulation, the methodology locates standardization strategies that optimize these criteria, e.g., finds standardization strategies that are Pareto-optimal in reducing construction time and structural weight.

The program's flexibility is the ability to choose from these standardization strategies later, depending on how uncertainty unfolds. Because the screened designs are Pareto-optimal in maximizing effects that do not depend on uncertainty, the choice of one of these designs will be optimal in the future. For example, assume two potential designs for the second asset, one minimizing structural weight and the other minimizing construction cycle time. If these designs are Pareto-optimal, then one cannot obtain a weight reduction without increasing cycle time. In the future, the weight-minimizing design might be chosen if the price of construction material is high and the price of the output products is low; the faster-to-build design will be chosen if the reverse conditions prevail. Whilst it is not known a-priori which design will be chosen (because the future prices of construction material and outputs are unknown), it is sure that it will be one of the Pareto-optimal designs.

The flexibility to choose the design and development timing of the second asset in the future is inherent to the value of the entire program. Moreover, if the designer of the first asset is able to influence the flexibility available to the designer of the second asset, then there is an opportunity for value creation. This is the value of flexibility engineers can design into engineering systems through standardization.

1.5.2 Contributions

The intellectual and practical value of this thesis lies in operationalizing the concepts described above; i.e., providing a structured and systematic process that enables the exploration of platform design opportunities and flexibility for programs of large-scale systems. Platform design in large-scale projects is inherently a multi-disciplinary effort, subject to multiple uncertainties and qualitative and quantitative external inputs. To the best of the author's knowledge, no such design management methodology exists to date, that is (a) suitable for large-scale, complex projects; (b) modular, with modules that are based on tried and tested methods or practices; (c) open to inter-disciplinary and qualitative expert opinion; (d) effectively a basis for communication between the traditionally distinct disciplines of engineering and finance. Each of the two steps in the proposed methodology is a novel contribution.

Invariant Design Rules This is a novel methodology and algorithm for the exploration of standardization opportunities at multiple levels of system aggregation, among variants within a program of developments. The Invariant Design Rules are sets of components whose design specifications are made insensitive to changes in the projects' functional requirements, so that they can be standardized and provide "rules" for the design of customized components. The IDR methodology uses Sensitivity Design Structure Matrices (SDSM) to represent change propagation through the system and a novel algorithm for separating customized systems and invariant design rules.

Engineering flexibility valuation The program's flexibility is the ability to choose from these standardization strategies later, depending on how uncertainty unfolds. For the entire methodology to have impact, the valuation of this flexibility must be performed in an engineering context. With this rationale, a novel real option valuation process is developed, that overcomes some presumed contributors to real options analysis' limited appeal in engineering. The proposed methodology deviates very little from current "sensitivity analysis," practices in design evaluation. Firstly, a graphical language is introduced to communicate and map engineering decisions to real option structures and equations. These equations are then solved using a generalized, simulation-based methodology that uses real-world probability dynamics and invokes equilibrium, rather than no-arbitrage arguments for options pricing.

The real options valuation algorithm can appeal to the engineering community because it is designed to overcome the barriers met by most real option approaches to design so far. At the same time, the algorithm is correct from a diversified investor's perspective under certain conditions.

1.6 Thesis outline

Chapter 2 provides a brief literature review of the basic modules of this thesis: platform design and development, standardization benefits in engineering and manufacturing, flexibility design and real options. Chapter 3 develops the Invariant Design Rules methodology and algorithm in detail. Chapter 4 explains the real option valuation methodology, and presents preliminary results compared to published benchmarks. Chapter 5 brings together these methodologies, in a case study on standardization between multi-billion dollar Floating Production, Storage and Offloading (FPSO) units for oil production. A final chapter summarizes the thesis and proposes directions for future research.

Chapter 2

Literature Review

2.1 Introduction

This chapter provides the intellectual support for the thesis as documented in the academic and practical literature. As the problem statement is multi-disciplinary, so is the body of knowledge that supports this work. Section 2.2 begins with an account of platforms. In the product design literature, a primary problem is to design a set of components that is common between variants in such a way as to maximize the value of the entire product family. Recent contributions in this field show that uncertainty in the specifications of future variants should be a driver for the design of the initial platforms. Specifically, some recent literature is based on the hypothesis that real option value should be the objective for platform design decisions; by including real option value in the objective function it is possible to account for the organization's flexibility to release new products on the basis of existing platforms. Similar ideas are also found in the management strategy literature to describe organizations and their evolution through time. In this sense, a platform represents all the core capabilities of an organization, not just physical infrastructure, that enables the organization to evolve, so the word "platform" is often used to mean "springboard." Just as physical product platforms enable the release of new products, core capabilities enable the evolution of organizations.

The flexibility to evolve, be it a product family or an entire organization, has been conceptualized as a portfolio of real options. These real options can be valued using *contingent claims analysis*, a methodology for modeling and quantifying flexibility, that is based on a deeply mathematical theory in finance and economics. Section 2.6 summarizes the basics of options theory, some applications in valuing managerial flexibility and how it can be applied to flexibility in real systems.

The chapter concludes with a research gap analysis. As described in Chapter 1, this research provides two engineering management tools that extend the respective literature strands. A proposed technical methodology for screening dominant standardization opportunities among system variants extends the platform design literature. The real options

literature, particularly in the context of engineering design, is extended with a methodology for mapping design and development decisions to structures of real options, and a simulation-based valuation algorithm designed to be close to current engineering practice and correct from an economics perspective.

2.2 Product platforms and families

“A platform is the common components, interfaces and processes within a product family” (Meyer & Lehnerd 1997). The development of platform-based product families involves the standardization of certain components and their interfaces with the non-standardized components. More generally, a platform strategy involves all the engineering and management decisions on how, when and what product variants and platforms to develop.

At the extreme, a platform strategy involves the standardization of most of a product’s components: it is the paradigm set by Henry Ford. At the other extreme, the customization of a product can rely on the customization of all of its components, which is the case with integral, as opposed to modular, products. An intermediate solution is enabled with the partial customization of components within a family of products; the part that is not customized is the platform for that product family. Firms, particularly in the automotive industry, are leading the field in developing extremely customized products based on very small numbers of product families. Consumer products and electronics are also often based on few platforms, whilst offering a great variety of functional characteristics to the end user; e.g., see Simpson (2004), Meyer & Lehnerd (1997) for case studies on Black and Decker’s electric motor platform for power tools. In achieving “mass customization,” as this trend is often called, firms have to balance the tradeoffs between developing too many and too few variants on a single platform. Figure 2-1 shows the average number of vehicle variants based on a single platform for 5 major automobile manufacturers (current and projected). Even though there is a clear trend to base more variants on a single platform, there also seems to be an “optimum equilibrium” which changes over time. For example, Toyota seem to plan to base 5 variants off of a single platform on average by 2006, from 4 in 2004; Honda is shown to go from 2 to 3 in the same time frame. This reflects a balance between the benefits and costs of developing product families, which depend both on static factors, evolving technology and a changing dynamic marketplace.

On the upside, platform design leads to common manufacturing processes, technology, knowledge transfer across the organization and its supply chain and reduction in manufacturing assets and tooling. From an organizational viewpoint, a product platform enables the firm to have a cross-functional team within product development; this in turn makes product and process integration much easier and less risky. In a more dynamic context, platform design enables the manufacturing organization to delay the so-called “point of differentiation:” this is the first instance in time that (a) the design and (b) the fabrication of two products in the same family begins to differ. Delayed differentiation (or postponement,

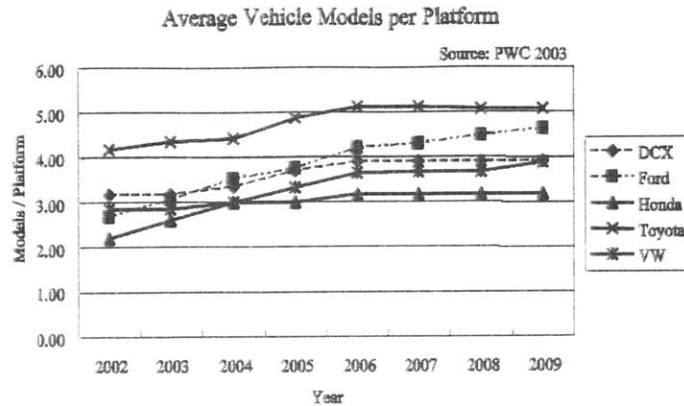

Figure 2-1: Platform utilization among major automotive manufacturers (Suh 2005)

as it is referred to in the supply chain literature) enables just-in-time production and faster reactions to fluctuating demand. According to Ward, et al. (1995), delayed differentiation in design is a key driver of Toyota’s excellence in development time and quality. In short, platforms in manufacturing lead to lower design and production costs, higher productivity in new product development, reduction in lead times, and increased manufacturing flexibility.

On the other hand, basing a range of products on a platform can have disadvantages. In the short term, the initial cost of developing a platform is often much higher than the cost of designing and producing a single product (Ulrich & Eppinger 1999). This cost increase is accompanied by an increase in technical risks: since many product variants are based on the same platform, the likelihood and impact of technical errors in the design of the platform is larger. Furthermore, sharing too many components may reduce the perceived differentiation between products in a family. This was reported to be the case with the automobile brands belonging to Volkswagen, which were perceived by the public to be too similar to justify their price differences. Furthermore, in the long term platform design may increase an organization’s risk exposure: the platform development cost has to be recouped from savings that depend largely on the number of variants produced and the production volume for each one. The increased risk in platform development arises because of the uncertainty regarding future demand for the variants. Finally, by developing platforms, organizations inadvertently lock in to the platform’s technology, architecture and supply chain; after all, this is exactly the source of production cost reductions. Locking in for the long-term however, reduces the organization’s ability to evolve.

Because of these benefits and costs associated with a platform strategy, there is extensive literature on the optimization of a platform and a family of products. Jose & Tollenaere (2005) write: “*the selection of a platform requires a comprehensive balance of the number of special modules versus the number of common modules.*”

To address this question, the platform design literature has encountered two main challenges: firstly, the organization of a complex system into modules and the identification of a common module (platform) in the product family. The second area of research has been to quantify the benefits arising from a platform strategy. For fairly simple systems, platform identification and family design optimization have been integrated in a single optimization framework. For an extensive review of the current literature on product platform design see Simpson (2004), Simpson, et al. (2006) and Jose & Tollenaere (2005). Section 2.3 provides a brief account of the benefits of platform design in design and manufacturing as documented in the literature over many years. Section 2.4 summarizes recent progress in modeling these benefits in platform evaluation and selection methods.

2.3 Platform and standardization benefits

Some of the platform benefits experienced in the automotive industry were described briefly above. A comprehensive account of the benefits organizations should consider before moving to a platform design strategy, including quantifiable as well as “soft” criteria, is given in Simpson, et al. (2005). Regarding the portfolio of platformed products as a whole, platform benefits include increased customer satisfaction, product variety, organizational alignment, upgrade flexibility, reliability and service benefits, change flexibility, ease of assembly and others.

In this section the focus is on the platform benefits experienced by design and manufacturing organizations of larger-scale systems that are produced in smaller quantities than consumer products, e.g., airplanes, ships or infrastructure. Important standardization benefits for these classes of products, that are usually overlooked in consumer products, are learning curve effects and spare part inventory management efficiencies.

2.3.1 Learning curve effects

Learning curves, generally experience curves, were first systematically observed and quantified at the Wright-Patterson Air Force Base in the United States in 1936 (Wright 1936). It was determined that manufacturing labor time decreased by 10-15% for every doubling of aircraft production. The scope of the effect was extended in the late 1960’s and early 1970’s by Bruce Henderson at the Boston Consulting Group (Henderson 1972). “Experience curves,” as the extended concept is called, includes more improvements than cycle time, e.g., production cost, materials, administrative expenses, distribution cost savings etc.

Interestingly, the quantification of these effects reveals that the percent improvement is constant as the number of repetitions (i.e., production volume) increases. A commonly used model for learning curves is based on power laws, i.e.,

$$y_x = y_1 x^z$$

where y_x represents production time (or cost) needed to produce the x 'th unit of a series; $z = \ln b / \ln 2$; and b is the constant learning curve factor. Typical learning curve factors are shown in Table 2.1.

Table 2.1: Typical learning curve factors (NASA 2005)

Industry	b
Aerospace	85%
Shipbuilding	80-85%
Complex machine tools for new models	75-85%
Repetitive electronics manufacturing	90-95%
Repetitive machining or punch-press operations	90-95%
Repetitive electrical operations	75-85%
Repetitive welding operations	90%
Raw materials	93-96 %
Purchased Parts	85-88 %

The major contributors and justification for experience curves are found in the physical construction and manufacturing processes. Repetition causes fewer mistakes, encourages more confidence and less hesitation among workers. Production processes become standardized and more efficient, making better use of equipment and allocation of resources. In a well-managed supply chain, these benefits are experienced by suppliers and reflected as the cost and time savings in the value of the final product; see Goldberg & Tow (2003), Ghemawat (1985), and Day & Montgomery (1983).

The same causes of experience curves are seen in industries of large scale systems implemented few times over the medium term. In the oil industry, repeat engineering and construction has been observed to have three major effects: firstly, capital expense (CAPEX) reduction, mainly due to repeat engineering and contracts with preferred suppliers. Secondly, value is created due to reduced operating expenses (OPEX) for the second and subsequent projects. This is mainly due to reduced risk in start-up efficiency, improved uptime, and commonality of spares and operator training. Finally, project engineers and managers use proven designs and commissioned interfaces without “re-inventing the wheel.” Standardization implies reduced front-end engineering design (FEED) effort requirements, fewer mistakes, increased productivity, learning etc., which in turn imply reduced cycle time. This can be extremely valuable by accelerating the receipt of cash flows from operations, thus increasing their value. Given a growing concern in the oil industry about the availability of trained petroleum engineers in the market, man-hour and cycle-time minimization becomes an even greater source of value.

Standardization has so far yielded hundreds of millions of dollars in value created for oil producing companies. For example, ExxonMobil’s Kizomba A and B developments offshore Angola are a recent example of a multi-project program delivered by the company’s “design

one, build many” approach, saving some 12% in capital expenses (circa \$400M) and 6 months in cycle time.

In manufacturing systems of consumer goods, the focus is in the long-run process improvement. As turn-over rates can be very fast, high production numbers are quickly reached, and the value of standardization cost savings depends mainly on the long-run average production cost (Figure 2-2). For large-scale systems, the main learning effect of concern occurs on the left of the experience curve (e.g., see Figure 5-8, p. 122).

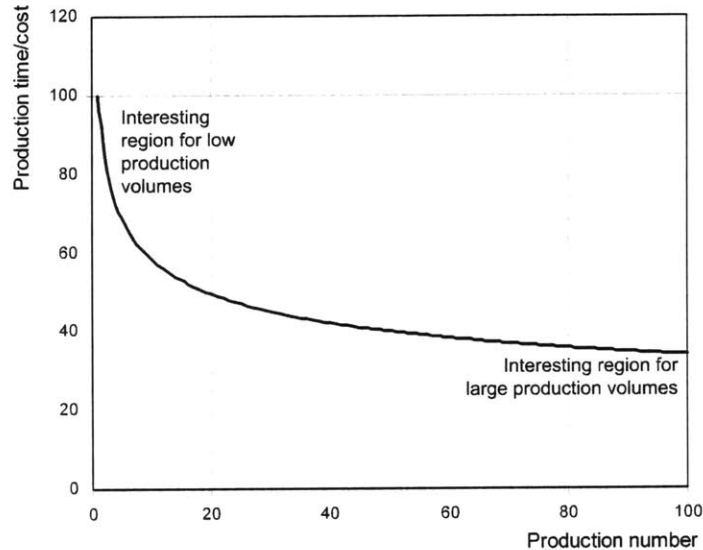

Figure 2-2: 85% learning curve

2.3.2 Maintenance, Repair and operations benefits

Standardization among large-scale capital projects can bring significant operating cost benefits, compared to distinct developments. The nature of these depends on the system under consideration. For example, the standardization of the heating system and cold water systems across more than 80% of the MIT campus enables their supply from a central co-generation plant, saving millions of dollars over their lifetime (MIT Facilities Office 2006). Standardization improves operations over the long run because of reduced training requirements; e.g., Southwest Airlines, utilizing a single type of aircraft (Boeing 737), experiences much smaller pilot and crew training costs, as well as increased operational flexibility in contingency crew assignments. For oil production facilities, standardization yields significant operational savings because of spare part inventories and maintenance.

The literature on inventory control of production resources or finished goods is very extensive; however, the literature on spare part inventories is fairly limited. Additionally,

the usability and application of the former models to spare part inventory problems is limited, because consumption of spare parts is usually very low and very erratic, and lead times are long and stochastic (Fortuin & Martin 1999). A review of these models is given in Kennedy, et al. (2000), while a number of case studies illustrate the problem and how it is practically resolved (Botter & Fortuin 2000). Trimp, et al. (2004) focus on a practical methodology for spare part inventory management in oil production facilities, and they base their study on E-SPIR, an electronic decision tool developed by Shell Global Solutions.

Costs of spare part inventory contribute significantly to overall operating expenses for oil production facilities. Even though equipment failure is a rare event, occurring usually only every few years, its impact has severe consequences. The lead time from failure to repair is often large, so that the opportunity cost of lost production is extremely high. Additionally, the holding costs for spare parts (including storage, handling, cost of capital etc.) are significant. Because of this, the trade-off between holding costs and the impact of a potential failure is real, and the optimal management of spare part inventories can have a significant impact on profitability. This is indicated by the recent trend in many oil producers towards reduced inventories, despite the fact that traditionally very large spare part inventories were maintained. In this context, standardization can be a significant source of value by reducing the inventory size for standardized components.

Spare parts contribute to operating costs through their acquisition and holding costs. Holding costs include all expenses, direct or indirect, to keep a spare part in stock. They typically involve storage space, insurance, damage, deterioration and maintenance. In practice, holding costs per inventory item can be estimated as percentages of its acquisition cost, and they typically range from 10% to 15% annually. The total inventory costs for a spare part will be the holding cost per item, times the minimum stock. The minimum stock is the minimum quantity of a spare part optimally held in inventory; when inventory levels fall below that, additional items are ordered until the inventory level reaches its optimal level. To determine the minimum stock that should be optimally held, the holding cost for that part must be compared to the expected cost of the part being unavailable when needed. This depends on several factors: (a) the lead time before the part is replaced; (b) the opportunity cost of downtime; (c) and the demand for that part during downtime. Assuming that (c) is known, e.g., if the spare part is vital to production, the other two factors determine the minimum economic stock to be held.

In summary, the most important factors that determine re-stocking and inventory decisions for spare parts are (Fortuin & Martin 1999):

- demand intensity;
- purchasing lead time;
- delivery time;
- planning horizon;

- essentiality, vitality, criticality of a part;
- price of a service part;
- costs of stock keeping;
- (re)ordering costs.

Fortuin & Martin (1999) also suggest qualitative strategies to effectively improve the average cost of inventory costs for spare parts. These strategies are based on affecting the factors above, directly or indirectly. The most relevant to this work concerns standardization of tooling and processes, combined with pooling of demand for spare parts among co-located clients. Assuming that component failures in physically uncoupled machines that perform the same action are independent events, then standardization can increase aggregate demand for spare parts, reduce inventory requirements and improve demand planning. In turn, this can have a great impact on operating expenses and value.

To obtain a sense of magnitude for the reduction in inventory size when demand for spare components is pooled, assume that each of N facilities achieves a particular function using a customized machine design. Each machine requires an inventory of X spare components for anticipated and scheduled maintenance operations. Assuming that failures of the component follow a Poisson distribution, and that availability is required for around 95% of planned and unanticipated maintenance events, then the total inventory requirement for this part among the N facilities can be estimated as

$$\text{Customized components inventory for } N \text{ facilities} = N(X + \sqrt{X})$$

This is because the standard deviation of a Poisson distribution is equal to the square root of its mean, and that one standard deviation of a Poisson process will cover around 95% of the random variation (de Neufville 1976).

If the facilities use the same machine design so that the spare component is standardized among the N facilities, then it will be possible to pool demand and reduce the inventory level. The inventory required among N users of the same part can be estimated as

$$\text{Standardized components inventory for } N \text{ facilities} = NX + \sqrt{NX}$$

Based on the above, the percent reduction in average inventory levels over a period of time can be estimated as shown in Figure 2-3, for $N = 2, 3$ and 4 facilities sharing the same part. These estimates are similar to the ones expected in resource and demand pooling in other contexts, e.g., see Steuart (1974) and de Neufville & Belin (2002) for a similar analysis in airport gate sharing.

2.4 Platform selection and evaluation

For some systems, the choice of the platform systems or processes between variants is simple: it may be intuitive or emerge naturally from existing variants. Potential platforms are

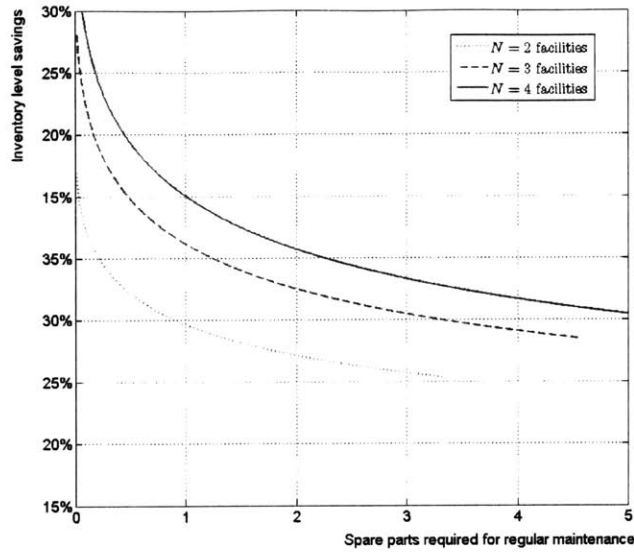

Figure 2-3: Estimated inventory level savings due to standardization and demand pooling

those systems that act as “buses” in some way (Yu & Goldberg 2003), or those that provide interfaces between other, customized systems. Indeed, most product platforms are selected intuitively, both in practice and in the academic literature. However, the deliberate identification of platforms is more difficult in network-like systems or systems in which platforms are comprised of subsystems and components from various levels of system aggregation. Platform identification is equally cumbersome in very large and complex systems, because the full design space for selecting different platform variables is combinatorial: for a system of n variables or components, the number of all possible combinations of variables that may belong to the platform is:

$$\binom{n}{n} + \binom{n}{n-1} + \dots + \binom{n}{2} + \binom{n}{1} = 2^n$$

where $\binom{n}{x}$ means “choose x out of n items (to be common among variants).”

Existing methodologies for platform selection deal with this combinatorial problem in two ways. One approach has been to limit the size of the combinatorial space with the use of semi-qualitative tools, and then allow design managers to select a viable partitioning. Another approach has been to search for optimal partitions of the system variables in customized and standardized modules using optimization heuristics.

2.4.1 Optimized search for platform strategies

This approach involves modeling net profit (or cost) as a function of the design characteristics of variants, then maximizing profit (or minimizing cost) by changing the design variables that comprise the platform. For example, Fujita, et al. (1999) formulate the platform selection problem as a 0-1 integer program coupled with the platform and variant optimization problem. Also, Simpson & D’Souza (2003) solve the problem of platform identification and optimization in a single stage using a multi-objective genetic algorithm, where part of the genome in the algorithm “decides” which variables are part of the platform and activates appropriate constraints.

This approach requires an engineering system model as well as a model of the benefits of each platform strategy. Then, integrating the platform identification problem with the product family optimization problem is computationally intensive but fairly straight-forward. Therefore, the applicability of these algorithms is limited by computational capabilities and the reliability of the system model. For large-scale systems, models that are accurate enough are difficult to construct. Furthermore, mapping the design variables to the benefits from a platform strategy requires multi-disciplinary input and is not straight-forward (even though there is research in that direction; see e.g., Simpson, et al. (2005)). For example, soft marketing factors, flexibility in variant development, supply chain agreements, long-term client agreements, in-house expertise or plain human aspects of design and development are difficult to include in these models. For these reasons, platform identification in complex systems is seen mostly as a heuristic design management activity in current practice.

2.4.2 Heuristic identification of platform strategies

An alternative approach aims at the “manual” identification of platform components in a product family by organizing the variables and components into modules and then investigating promising selections of modules for a platform. The principle is that the design of platform modules must be “robust” to the changes in specifications between product variants, whilst the customized modules must be “flexible” (Fricke & Schultz 2005). The starting point in this search is therefore the desired changes in functional attributes between variants. Then, it is necessary to know how these changes propagate through the specifications of system modules. In their pioneering work, Eckert, et al. (2004) classify system elements as change propagators, magnifiers or absorbers, depending on how much change in the design of the entire system is brought on by changes in their own specifications. This has been an important first step in the characterization of system modules with respect to change. Similarly, Martin & Ishii (2002) develop a tabular methodology for computing indices of the degree of coupling between components in a system. These effectively determine how amenable to evolution each system component is. Suh (2005) develops this further by observing that change multipliers may not be necessarily expensive to change

between variants; accordingly, he introduces indices for the increase in cost and complexity in a system design, required to respond to a change in specifications.

Both Martin & Ishii (2002) and Suh (2005) build on the Design Structure Matrix (DSM) methodology for representing relationships and interactions between system components. As a system representation tool, the DSM was invented by Donald Stewart (Stewart 1981), even though some of the methods for organizing a DSM, particularly partitioning and tearing, were already known from the 1960's in the chemical engineering literature; see, e.g., Sargent & Westerberg (1964) or Kehat & Shacham (1973). In the 1990s, DSM's were developed further and used to assist design management; they provided a succinct way of modeling and re-structuring the flow of information in a design organization; see, e.g., Eppinger, et al. (1994), Kusiak (1990), Gebala & Eppinger (1991), Kusiak & Larson (1994), Eppinger & Gulati (1996). In the last decade, the DSM methodology has been used extensively in system decomposition and integration studies. For an excellent review see Browning (2001). Recent research using DSMs has extended the scope of the method by including parameters external to the system and examining how these parameters affect components within the system. Sullivan, et al. (2001) have developed such an extension for the purpose of identifying invariable modules in software architecture given changes in the design requirements of other modules. Besides, Yassine & Falkenburg (1999) introduced the concept of a sensitivity DSM, and linked the DSM methodology with Suh's Axiomatic Design principles (Suh 1990). This research extends the literature of platform identification and design using DSMs, with the introduction of an innovation in the definition, construction and partitioning.

2.4.3 Product platform evaluation and design

A parallel strand of literature has attempted to evaluate an entire platform strategy, i.e., the entire deployment plan for the platform and the variants, in terms of the costs and benefits of developing a platform. These are then combined in an economic criterion, e.g., for commercial systems and products, the net present value (NPV) of the platform strategy. Traditionally, the NPV is calculated considering the expected value of uncertain future design requirements, technology, and market conditions for subsequent variants. However, because (1) the value of a platform strategy does not depend linearly on these uncertainties, and (2) the deployment of variants in the future is not mandatory, but in the discretion of the developing organization, these uncertainties must be taken into account explicitly for the design of the initial platform. The design and deployment plan for product variants under uncertain conditions has been the subject of extensive research. Gonzalez-Zugasti, et al. (2001) develop a two-step methodology for designing product platforms and variants: first, the family is optimized for a set of deterministic technical objectives; then the value of the product family to the firm is calculated, considering the uncertainty in profits from its development. The framework is captured in Figure 2-4.

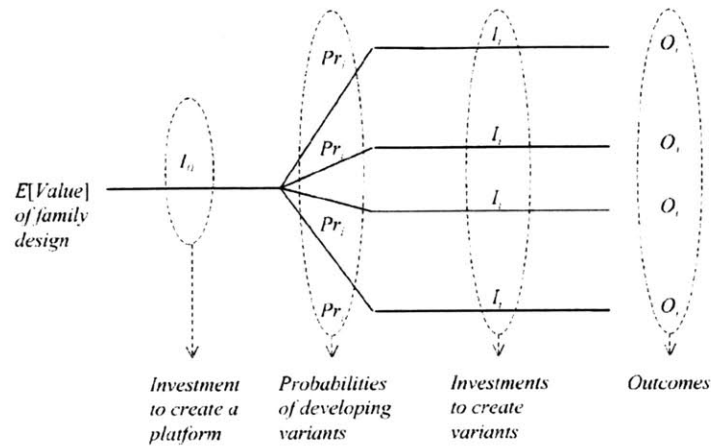

Figure 2-4: Two-step process for designing platform variants (Gonzalez-Zugasti et al. 2001)

The pioneering work by Baldwin & Clark (2000) is closely related to this framework, and focuses on how uncertainty regarding the net value of individual modules in a system should affect the design of the system architecture, i.e., the separation of the system into modules and “design rules.” The design rules are collections of modules that dictate the design of the other modules in the system; in this sense, they are synonymous to platform modules or variables. The customized modules must conform to the specifications laid out in the design rules. The representation of the system and its partitioning in modules and design rules can be facilitated by design structure matrices. The net value of a module is modeled as a function of its contribution to the value of the entire system minus the cost of fitting it into the system, and is considered uncertain with a known distribution. The selection of design rules and modules in the system is done so as to maximize net value, which includes the value of flexibility to interchange existing modules with ones of higher value. An application of this model can be found in Sharman, et al. (2002). Martin & Ishii (2002) develop a framework for platform design, when it is required to support future evolutions of the current family of variants. Again, there is uncertainty regarding future requirements for the variants as well as the available technology for modules in the system (i.e., the value of these modules). According to their framework the product platform has to account for the spatial variety in the product family at any time as well as generational variety for each product in the family through time (see Figure 2-5).

The frameworks by Martin & Ishii (2002) and Gonzalez-Zugasti et al. (2001) account for uncertainty, both spatial and with respect to time, in the design requirements of future variants. However, they do not explicitly account for the organization’s *flexibility* to develop subsequent variants using an existing platform, or the flexibility to lever more standardization benefits on an existing platform by continuing the production of existing variants. In this sense, platforms are enablers for future strategic design and development decisions.

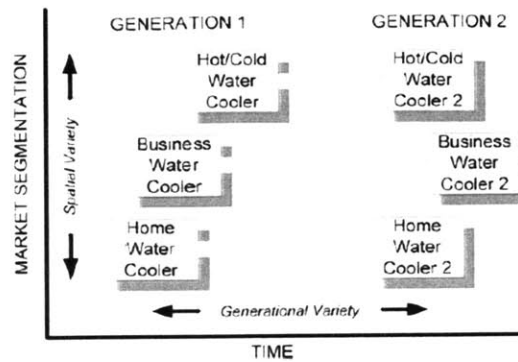

Figure 2-5: Design for variety: spatial and temporal evolution of product families (Martin & Ishii 2002)

Regarding platforms as enablers for future actions is not a new idea in engineering. Related work can be found in Geppert & Roessler (2001), who conceptually examine the release of new product variants through a real options and flexibility viewpoint. Mavris & Fernandez (2003) adds operational detail to Geppert & Roessler’s (2001) concepts in a case example, by integrating real options analysis into an engine development decision support system. Sivaloganathan & Sahin (1999) mention design reuse as a vehicle for an organization to move between market segments, by merging existing designs with innovation to move forward and develop a common core design. However, the value of platforms as enablers becomes more apparent in the strategic management literature. Section 2.5 summarizes relevant contributions.

2.5 Strategic view of platforms

The strategic management literature extends the “engineering” definitions of platforms. Muffato (1999) writes that a platform strategy should consider a number of issues that are commonly disregarded in engineering; particularly,

- the technical relationships between platforms and models and between platforms themselves
- the organization’s relationship with the supplier and customer base, and
- the organization’s relationship with subsidiaries in other countries and with other companies.

In short, the effect of a platform strategy has a broad effect on the developing organization. Robertson & Ulrich (1998) write that platforms are collections of assets that can be

characterized as components (i.e., hardware, software and tooling used repeatedly for the production of a known collection of products), processes (i.e., the manufacturing or supply chain technology, logistics etc.), knowledge (e.g., design know-how) and people. The platform is those elements that characterize the core competencies of the organization and are commonly utilized in its operations. McGrath (2001) extends this definition and broadly refers to a product platform as a “*definition of planning, decision-making, and strategic thinking.*” He adds: “*it is the set of architectural rules and technology elements that enable multiple product offerings and defines the basic value proposition, competitive differentiation, capabilities, cost structure and life-cycle of these offerings.*” Kristjansson & Hildre (2004) offer a framework for evaluating platforms in product-oriented organizations, as well as an inclusive and very broad definition: “a platform consists of all assets that enable competitive advantage.” The interpretation of these “assets” has varied: Fichman (2004) writes that common (platform) information technology infrastructure enables business related opportunities; Hofer & Halman (2004) argues that the physical layout of components, furniture and other physical elements in certain occasions is a platform. These definitions show that platforms can be perceived as an organization’s core capability.

These capabilities give organizations the opportunity to expand their operations vertically, within the extent of their competencies, but also horizontally, beyond the existing “platform.” In fact, these core competencies are options in the hand of organizations to invest in new ventures. Moreover, the options available to the organization, i.e., the investment opportunities and their value, are directly linked to its core organizational competencies; see Kogut & Kulatilaka (2001). As a collection of options, the value of a platform (i.e., the value of an organization’s core competencies) depends on uncertainty, opportunity, time dependence and discretion; see Kulatilaka (1994). “Opportunity” refers to the range of different paths the current core competencies of an organization allow it; “time dependence” refers to the conditions that make opportunities more or less attractive over time, such as competition or the actions of the firm itself; “discretion” relates to the extent to which new ventures represent a right but not an obligation. Organizations that strive to maximize their value in effect attempt to maximize the value of their associated options.

Helfat & Raubitschek (2000) extend these concepts to include product sequencing: the organizational capabilities platform evolves together with the firm’s products. Undertaking different ventures results in the enhancement of different aspects of the organization’s capabilities, and eventually leads to different expansion paths in the organization’s size, products and market specialization. They mention Canon, an electronics manufacturer, as a striking example of expansion paths in time, market and scale, enabled by the evolution of the core competencies comprising the firm’s platform. Canon started by specializing in mechanical cameras in the 1930’s. In the 1960s it utilized its expertise in mechanical assemblies and precision optics to compete with Xerox in the photocopier market. At the same time, Canon produced its first handheld calculator. In 1976, Canon was able to combine its patents and expertise in microelectronics (acquired from the calculator business unit) with

its experience in mechanics and optics to introduce AE-1, the first fully-automatic 35mm single-lens-reflex (SLR) camera with a built-in microprocessor, and an innovation in terms of both performance and cost. It is not known if Canon reused actual processor designs in the AE-1, but it definitely based this innovation on the knowledge platforms it had created with calculators and mechanical cameras.

Such expansion paths result from the strategic exercise of options: at the time Canon was producing mechanical cameras and calculators with a knowledge platform in each field, it exercised its option to integrate the two technologies. However, it is unlikely that Canon deliberately developed calculators in order to acquire the knowledge to later design electronic cameras; this was an unplanned option. Such options exist in almost all projects, e.g., the option to abandon a project whose value declines is almost always available and does not require any proactive thinking or planning (unless very large termination costs are involved).

This research is concerned with options available to the firm because they have been planned and designed. In the context of Canon's example, the goal of this thesis is to enable firms to proactively develop both "calculators" and "mechanical cameras" as part of the same program of projects, which eventually might include a fully-automatic camera such as the AE-1. This level of planning might be impossible in cases like Canon's: the range of future possibilities is so rich, and the path dependencies tracing the various product and market expansion paths are so intense, that the problem is intractable both computationally and conceptually; see Adner & Levinthal (2004). The intractability of the problem in many situations is the main reason why the application of options in the organizational learning and platform evolution has remained at the conceptual level only, e.g., Luehrman (1998b), and its penetration as an analytical tool is limited, e.g., Luehrman (1998a).

However, for large-scale engineering systems the possible expansion paths are often much more tractable. In many situations the core competencies of an organization, i.e., the platform of capabilities, can be linked directly to the physical entities it develops. Learning can also be easier to assess and document. Additionally, the number of market segments, competitors or other driving uncertainties may also be more limited. Finally, competitive advantage may not depend on unpredictable technological innovation (as in Canon's case), but on design, production and supply chain excellence as in Toyota's case (Vasilash 2000). In such cases, the expansion paths of the organizational core capabilities can be mapped onto the physical platforms that are common in product families. Moreover, these expansion paths are governed by physical and engineering laws, so they are limited. Therefore, the problem of designing and planning the options associated with platforms is tractable in some engineering organizations.

This research adds operational value to these concepts, by providing a method of designing tangible, physical platforms that enable the organizational platforms and options for the future. This results in better engineering designs, in that they enable their developers or operators real options for the future.

2.6 Flexibility and real options

The investment opportunities available to a firm can be described as real options because they represented a right without the obligation to enter new ventures. This thesis uses real options to assess the flexibility benefits organizations create by developing programs of projects, to value alternative designs and to guide design decisions. This analysis involves a departure from the current trend in academia, of applying options theory directly to real projects and problems, as this approach has not managed to penetrate operational practice. The starting point of this departure is the current practice of real options applications and thinking. This section reviews, organizes and frames the literature on real options as a valuation methodology and as a way of thinking.

In a narrow sense, the real options literature builds on an analogy between projects and investment opportunities, and plain vanilla financial options (Amram & Kulatilaka 1999). The latter are contracts enabling the holder of the option to buy (or sell) a security at a specified exercise price in the future, within a pre-determined time window. The holder's right (without the obligation) and the underwriter's obligation to fulfill the holder's right, gives an option contract its value at the time it is written. Calculating this value was an unsolved problem in economics since the early 20th century. The solution came in closed form with the Black-Scholes formula (Merton 1973), which enabled the calculation of the value of a European call option on a non-dividend paying stock. Hundreds of publications since have used the same or similar mathematical construction as Black and Scholes did, to value options contracts with a variety of characteristics. These exercises shared two common goals: (a) to find the value of such a contract, and (b) to find the "optimal exercise rule," i.e., the conditions under which it would be optimal to exercise the option.

Steward Myers first extended the concept of an option to situations where no formal contract is written; instead, the "holder" of the "option" has the right (without the obligation) to instigate a specific action within a timeframe in the future; see Myers & Brealey (2000) and Dixit & Pindyk (1994). This was a conceptual breakthrough: the options methodology was used to value non-financial assets whose value just depended on an observable financial entity and the asset owner's actions. The solution of many "riddles" in classical microeconomics was found through the options lens: e.g., vacant urban land that could support immediate profitable construction was explained as an option: the land owner had the option to develop the land in the future, which they optimally did not exercise immediately.

Most initial applications of options theory to real investment problems have a strong positive character: the theory was used to provide rational explanation to market phenomena; it was a tool for economic analysis. Capozza & Li (1994) and Williams (1997) developed models to explain vacant urban land, mentioned above; also Grenadier (1996) used options theory to explain over-building in real estate markets. These models built on Samuelson's (1965) model for the price of perpetual warrants, and were based on the similar nature of a warrant and a plot of land: the land gives the owner the perpetual right, but

not the obligation, to develop it in the same way a warrant is a perpetual right to obtain a company's stock. Holland, et al. (2000) as well as Quigg (1993) provide empirical evidence that options models indeed predict investors' behavior in observable real estate markets. A similar model was built by McDonald & Siegel (1986) in the capital budgeting literature to explain delays in investing. There are volumes of literature applying options theory to real estate development, capital budgeting and natural resource development. In these contexts, the theory served as a tool for explaining situations that had the same conceptual characteristics as financial options.

In parallel, the focus of real options research started to shift. It was realized that the evolution of an organization through discretionary actions, i.e., an organization's strategy, was the compounded result of exercised real options. The concept and methodology seemed to apply to any strategic decision, and as a result, there was an effort to put the methodology into the practitioner's toolbox as a normative investment valuation tool; see e.g., Dixit & Pindyk (1994), Luehrman (1998b) and Luehrman (1998a). Introducing the concept of real options in management found little resistance overall (Boer 2002); to the contrary, it provided some formalism to successful management thinking and practice.

Initially, the options valuation methodologies were very slow to penetrate management practice. In the literature, the concept of real options was tied to a set of assumptions that managers often found too formalistic and did not really believe. Besides, the mathematically elegant option models developed in the microeconomics literature were generally incomprehensible to non-academics. One of the first books to attempt to bridge this gap and introduce the rigorous options analysis to project valuation and practice was by Copeland & Antikarov (2001). In this "practitioner's guide," the authors showed how the rigorous theory could be easily used to value some simple real options, what assumptions the methodology entailed and what could limit its applicability. This work, as well as others, build on academic research and work on various types of real options; the ones most often encountered in the management of engineering systems relate to deferral of decisions, abandonment, growth, switching operational modes or all of the above. A brief account for each kind is presented below. This classification of options is only one of many found in the literature, and is certainly not conclusive. Trigeorgis (1996) gives a similar list; Vollert (2003) presents a comprehensive list of real options applications and categorizes them based on several attributes.

Option to defer investment. The holder of the option has the right, but not the obligation to delay investing a fixed amount to obtain a project whose value is uncertain because of uncertain input or output costs (McDonald & Siegel 1986). Delaying obtains more information about the operational environment of the project. The model can be used to value offshore oil leases (Paddock, et al. 1988) that give the owner the right to develop within the lease period, or land, that gives the owner the perpetual option to build; see Capozza & Li (1994) and Williams (1997).

Option to defer investment choice. Deferring investment also defers the choice of which project to develop; e.g., see Decamps, et al. (2003). To continue the real estate examples, Geltner, et al. (1996) extend the land development models mentioned above with the effect of multiple zoning: the developer may choose which of two uses (e.g., office or residential) to build. Interestingly, the choice between alternative uses is never (optimally) made as long as the value of the alternative uses is the same. This is because the choice is irreversible. Childs, et al. (1996) extend Geltner et al.'s (1996) results and find that the developer will choose between uses if a redevelopment option exists.

The two options of choosing the development project, and actually investing in it are very relevant for engineering systems: they represent the design and construction decisions respectively, that most large-scale developments go through. Since both stages require significant time and cost, they are distinguished explicitly as “development gates.” The first gates involve design and lock-in to a particular engineering solution; the latter gates involve construction and start-up. In smaller scale-systems such as consumer products, the development of a product family does not necessarily follow the same “gate” process: platforms can be designed and developed first, then variants can be designed based on those platforms (Li & Azram 2002). In the real options literature however, the two decisions are not modeled separately.

Option to abandon projects that become unfavorable during their construction or operation. Abandoning or postponing development of a project that yields benefits upon completion may be optimal if uncertainties evolve unfavorably during development; see Majd & Pindyck (1987) and Carr (1988). Similarly, shutting down permanently an operation that loses money may be optimal if the probability of recovery is low enough.

These are also the options associated with multiple-stage projects or pilot programs that test market conditions before full-scale release of a product: the option to abandon a full scale deployment is the same as the option to expand the half-scale pilot project. A relevant model (Myers & Majd 1990) shows how a project can be abandoned and its resources can be utilized differently.

Options to grow the scale of a project makes sense when the expansion path of growth is a sequence of inter-related projects, where earlier stages enable the options to subsequent ones (Kester 1993).

Options to switch inputs or outputs enable the holder to observe the uncertainties as they evolve and make adjustments to the resources required by a project or the outputs produced (Margrabe 1978). A well-known example is given in Kulatilaka (1993), where the value of a steam boiler that can switch from burning oil to gas and vice-versa is found as a function of the uncertainty in the prices of oil and gas. Such a boiler represents the value

of the option to switch production inputs. Switching production outputs is an interesting application in cases where the product mix suffers from internal competition.

Options to alter operating scale are relevant for projects that can change the scale of production to match demand (for unique products) or market price (for commodities). Such options can be used for choosing among technologies with different characteristics of variable and fixed production costs; see Triantis & Hodder (1990), Tannous (1996), and Brennan & Schwartz (1985). These options include the flexibility to temporarily shut-down entirely, perhaps incurring a running “moth-balling” cost in order to retain the option to resume production later. In other words, these are reversible options, just like options to switch inputs or outputs: reducing operating scale temporarily does not preclude resuming to full production in the future.

Combinations of the above (compound options) Most projects represent a combination of options: Staged projects involve options to abandon or grow to subsequent development phases; each phase may involve options on production scale and speed of development as well as operational options to mothball development; once operational, projects may entail operational flexibility regarding product mix or choice of inputs. Many examples in the literature value combinations of these irreversible and operational real options. Cortazar, et al. (2001) and Brennan & Schwartz (1985) examine multiple options in natural resource investments (oil production and copper mines). Grenadier (1995b) values the perpetual option to choose tenant mix in real estate projects (which is a form of input choice option) together with the option to choose the initial tenant type. In a more general model, Chen, et al. (1998) describe the evaluation of complex manufacturing processes as multiple operational options.

Combinations (or portfolios) of real options such as the above make up what is described as *managerial flexibility*. The development or operation of a project will allow its managers a host of decisions, reversible or not. The entire set of these decisions, i.e. the collection of real options associated with a project, is the flexibility inherent to the project. This can be viewed another way: real options (as the right but not the obligation to act) provide a framework for modeling all the managerial flexibility inherent to a project, provide a metric for the value of flexibility, and a theory for finding that value.

2.6.1 Flexibility and real options in engineering projects

Many of the options that comprise a project’s managerial flexibility are available anyway: no proactive actions are needed to “buy” these options and enable this flexibility. For example, the flexibility to abandon a project during its development exists most of the time; no special action beforehand is needed to obtain it. These options are important and may have great contribution to a project’s value.

In addition to these, there are options available to the firm because they have been planned beforehand in the design and management of a project; these real options are the focus of this research. Because they require deliberate planning and design, these options can be called “in” systems; see de Neufville (2002) and Wang & de Neufville (2005). Such options are most often related to the choices the firm can make for future projects, but can also relate to operational flexibility, the ratio of fixed to variable costs, changes in production scale, or the combinations of options during the development and operation of the project. Figure 2-6 shows the flexibility that system designers and developers can build into engineered systems in the form of real options.

		IN DESIGN	IN MANUFACTURING / PRODUCTION	IN LIFECYCLE / USE
MANAGERIAL FLEXIBILITY	Robustness	No system reconfiguration Uncertainty does not affect design decisions. On a parameter based DSM, uncertain parameters are decoupled from design decisions.	Uncertainty does not cause product to violate specifications. See Taguchi's robust design.	Feasible (or even optimal) operation regardless of level of uncertain parameters. Synonymous with resilience. <i>Examples:</i> chemical process design (Biegler, Grossman and Westenberg 1997).
	Operational flexibility	Costless reversible system reconfiguration Independent task structure matrices (TSM) or block-independent TSMs: design decisions can be made without constraining other design decisions. <i>Example:</i> modular computer design.	Process and volume flexibility (Sethi & Sethi 90), usually at machine or subsystem-level. <i>Examples:</i> slide-in adjustable wheelbase automotive chassis (Suh et al. 04); dual-fuel steam boiler (Kulatilaka 93)	Flexibility in use, without switching costs amounts to ownership of all states of the flexible system. <i>Example:</i> sofa convertible to bed; oil/gas extraction system with adjustable depth of recovery.
	Operational flexibility	Costly reversible system reconfiguration Sequential, block-hierarchical or coupled TSM: upstream design decisions constrain downstream ones (and vice-versa)	Product flexibility (Sethi & Sethi 90, Bengtsson 01), input/output flexibility. Difference with process and volume flexibility is only in the non-zero switching cost. <i>Examples:</i> extensible automotive chassis (Suh et al. 04); Modular space system (de Weck et al. 05)	Block-independent component-based design structure matrix (DSM). Modular systems. <i>Examples:</i> Flexible office spaces (Greden 05); OBO carriers- vessels built for the carriage of diversified bulk cargos (i.e. Oil/Bulk/Ore).
	Strategic flexibility	Irreversible system reconfiguration Legacy systems: the design and implementation of a decision “locks-in” subsequent decisions irreversibly. <i>Example:</i> the QWERTY keyboard design.	All other irreversible (in terms of switching costs) manufacturing decisions. <i>Examples:</i> expansion flexibility; the flexibility to choose the placement of a deep-water oil platform; BWB aircraft family (Markish & Willcox 02)	Irreversible switches in system use, either because of hierarchical/coupled DSM or because of large switching costs to go back. <i>Example:</i> Expansion/contraction of buildings (Zhao & Tseng 03, Kalligeros & de Weck 04).

Figure 2-6: Flexibility in engineering, manufacturing and operations

Despite the fact that this flexibility is conceptually known to developers and designers, engineering systems are traditionally designed to fixed specifications. This practice persists even when uncertainty regarding the system’s development or operating environment is acknowledged, implying that flexibility can be valuable. On the other hand, the *concept* of deliberately designing systems so that they enable engineering flexibility (e.g., to change specifications in the future) is slowly gaining momentum, both in academia and practice. For example, there have been academic efforts recently for the optimization of engineering systems based on the option value they create. Applications include phased deployment of communication satellite constellations under demand uncertainty (de Weck et al. 2003); decisions on component commonality between two aircraft of the same family (Markish &

Willcox 2003); building design under rent and space utilization uncertainty; see Zhao & Tseng (2003), Kalligeros & de Weck (2004), Greden & Glicksman (2004), and de Neufville, et al. (2006). Even if the concepts are appealing to forward-looking engineers, the analytical tools in these case studies, however, have been very slow in reaching practitioners.

2.6.2 Option valuation

In introductory descriptions of options theory, the (historically precedent) continuous-time approach is usually presented after more intuitive binomial trees. The reason is that these methods require some knowledge of stochastic calculus, are counter-intuitive and difficult to follow ¹ The presentation starts with the classic binomial scheme by Cox, et al. (1979) (CRR), which is ubiquitous in finance textbooks; e.g., Myers & Brealey (2000). Extensions of the CRR scheme can be found in Hull (2000). An alternative binomial model is then presented Arnold & Crack (2003), which is based on a discretization of the original continuous-time model of Black and Scholes. In ways that become apparent in Chapter 4, this scheme is more appropriate for valuation of managerial flexibility. A brief summary of a certain class of simulation methods is also presented, namely state aggregation algorithms, as they provide the basis for the valuation methodology introduced in this work.

Binomial Trees

Consider a plain vanilla “call” option written on a stock s . The contract gives the holder the right, but not the obligation to purchase one unit of the stock for an exercise price of X , at the latest at time T . If the purchase has not been made by that time, the option expires and the right is forfeited. The goal of the method is to find the value of such a contract as a function of the stock price s and the remaining time to expiration, $V(s, T - t)$. We are also interested in the conditions under which the holder should exercise the option and purchase the stock.

Cox et al. (1979) formed a binomial model for the evolution of the price of the stock starting from s_0 at time $t = 0$. A single time step δt into the future, assume that the value of s can be either s_u or s_d , with probabilities p and $1 - p$ respectively. The expected value of s at time $t + \delta t$ is $E[s] = ps_u + (1 - p)s_d$. If the stock is assumed to follow a Geometric Brownian Motion (GBM) with standard deviation of returns (volatility) over δt equal to σ and expected gross return over δt equal to $e^{r_s \delta t}$, then s_u , s_d and p can be found by matching the return and volatility of the binomial model with σ and $e^{r_s \delta t}$ and solving:

$$\begin{aligned} E[s] &= ps_u + (1 - p)s_d = se^{r_s \delta t} \\ E[s^2] - E[s]^2 &= ps_u^2 + (1 - p)s_d^2 - (ps_u + (1 - p)s_d)^2 = \sigma^2 \end{aligned}$$

¹Continuous-time option pricing is discussed at length in Dixit & Pindyk (1994), Dixit (1995) and Bjork (2003), to name only a few. Vollert (2003) solves options problems in a stochastic control framework. Numerical solutions to the continuous-time equations can be obtained with finite difference methods, see e.g., Tavella & Randall (2000).

These are two equations in three unknowns (s_u , s_d and p). To solve, an additional convention must be introduced. Cox et al. (1979) use $s_u = 1/s_d$; an alternative convention could be $p = 1/2$. With these three equations, the parameters of the binomial model s_u , s_d and p can be linked to the observed return and volatility of the stock.

At time $t + 2\delta t$, the value of s can be s_{uu} , s_{ud} , s_{du} or s_{dd} , depending on the path it has followed. It is also easy to calculate the (unconditional) probabilities of each event occurring. For example, if s is known at time t and the probabilities p are constant in time, the probability of s_{ud} at $t + 2\delta t$ is $2p(1 - p)$. This way, one can construct a “discretization” of the evolution of s in time, so that at time $t + j\delta t$, there are 2^j possible values of s , each with its own a-priori probability. However, if $s_u = 1/s_d$ as introduced previously, the lattice re-combines and the number of possible values of s at $t + j\delta t$ are reduced to just $j + 1$ (Figure 2-7).

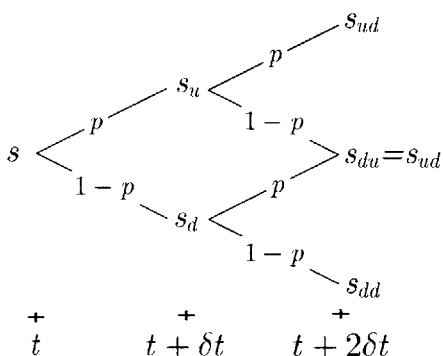

Figure 2-7: Two steps of a recombining binomial lattice of s

Replicating portfolio valuation Consider the value of the stock at time $T - \delta t$, i.e., one time step before the option’s expiration, and denote s the value of the stock at that time. The value of the option at time T will either be $\max(s_u - X, 0)$ or $\max(s_d - X, 0)$ with probabilities p and $1 - p$ respectively. Also, consider a portfolio of a shares of stock and the dollar amount b in riskless bonds. This portfolio has value $as + b$ at $T - \delta t$, and at time T it may have value $as_u + e^{rf\delta t}b$ or $as_d + e^{rf\delta t}b$, with probabilities p and $1 - p$ respectively. These future values of the portfolio can be made equal to the payoff of the option in this binomial world with appropriate selection of a and b . These values of a and b can be found by solving the system

$$\begin{aligned} V_u &= \max(s_u - X, 0) = as_u + e^{rf\delta t}b \\ V_d &= \max(s_d - X, 0) = as_d + e^{rf\delta t}b \end{aligned}$$

and are

$$\begin{aligned} a &= V_u - V_d s_u - s_d \\ b &= s_u V_d - s_d V_u (s_u - s_d) e^{rf\delta t} \end{aligned}$$

Since the value of a portfolio with a and b as calculated above is exactly equal at time T to the value of the call option, it follows that their values should be equal at time $T - \delta t$ as well. If this was not the case, then arbitrageurs would have the opportunity to make riskless profits by selling the portfolio and buying the call option, or vice-versa. Therefore, the value of the call option at time $T - \delta t$ is

$$V = as + e^{r_f \delta t} b = s \frac{V_u - V_d}{s_u - s_d} + \frac{s_u V_d - s_d V_u}{(s_u - s_d)} \quad (2.1)$$

Defining $u = s_u/s$ and $d = s_d/s$, Equation 2.1 becomes

$$V = e^{-r_f \delta t} \left[\left(\frac{e^{r_f \delta t} - d}{u - d} \right) V_u + \left(\frac{u - e^{r_f \delta t}}{u - d} \right) V_d \right] \quad (2.2)$$

Also, defining $q = (e^{r_f \delta t} - d)/(u - d)$ and $1 - q = (u - e^{r_f \delta t})/(u - d)$, equation 2.2 can be simplified as

$$V = e^{-r_f \delta t} [qV_u + (1 - q)V_d] \quad (2.3)$$

The last equation can be interpreted as an equivalent way for valuing the option. Notice that $d < e^{r_f \delta t} < u$ implies $0 < q < 1$. The fact that $d < e^{r_f \delta t} < u$ is certain in markets in equilibrium; otherwise, there it would be possible to obtain arbitrage profits just by trading on the stock and riskless bonds. If $0 < q < 1$, q can be interpreted as a probability, and equation 2.3 for the price of the option can be interpreted as an expectation of the future price of the option, assuming that the probabilities for the “up” and “down” movements are q and $1 - q$ respectively (instead of p and $1 - p$). These are in fact the probabilities of “up” and “down” movements of the stock price if investors required the risk-free rate for holding the stock, i.e., if investors were *risk-neutral*. Hence, this interpretation is the so-called “risk-neutral” valuation. It involves pretending that investors are risk-neutral so that the stock price evolves in a lattice where the probabilities of “up” and “down” movements are q and $1 - q$ respectively, and then calculating the value of holding the option at each node using formula 2.3. The probabilities of “up” and “down” movements would indeed be q and $1 - q$ if the investors trading the stock and the option were risk-neutral, i.e., did not require a risk premium for the risk in holding the stock; hence the name of the valuation method.

The extension of risk-neutral valuation to multi-period lattices, as well as situations where the underlying stock pays dividends is omitted; presentations can be found in Cox et al. (1979), Hull (2000), McDonald & Siegel (1984) and Copeland & Antikarov (2001).

Generalized Multi-Period Option Pricing

The risk-neutral valuation has been very useful in revealing the underlying economics in Black and Scholes’ model, in a simple presentation that has been used repeatedly in MBA-level finance textbooks. For real option applications, however, this methodology has been less than convincing, both for practical and conceptual reasons. One practical problem is

that, by assuming a risk-neutral evolution of the stock price, the method cannot return the true decision rules for the option, or the true probabilities that a real option would be exercised at some time: these results correspond to a “risk-neutral” world, even if the price of the real option is right in the real (risk-averse) world. Additional practical problems arise when the stock’s valuation does not rely solely on mean and variance of returns (as it was assumed above), but on other moments of the returns distribution. On a conceptual level, it has been difficult to convince practitioners and organizations that despite the risk in their operations, they should apply a methodology that seemingly discounts options at the risk-free rate.

Arnold & Crack (2003) present a methodology for “generalized option pricing.” The methodology is based an extension of the CRR scheme in that it uses the same binomial grid for the evolution of the underlying stock price and the option, with the parameters s_u , s_d and p determined in exactly the same way. Their pricing formula is given below.

$$V = e^{-r_f \delta t} \left[pV_u + (1 - p)V_d \right] - \frac{V_u - V_d}{u - d} \left[e^{r_s \delta t} - e^{r_f \delta t} \right] \quad (2.4)$$

In words, the Arnold and Crack formula reduces the expectation of the future value $pV_u + (1 - p)V_d$ of the option by an amount proportional to the risk in the option’s future value, $\frac{V_u - V_d}{u - d} [e^{r_s \delta t} - e^{r_f \delta t}]$. The reduction is such that the quantity in brackets is “certainty equivalent,” in other words, an investor would be indifferent between getting this amount for certain in the next period, or getting the risky option payoff. Because it is certainty equivalent, this amount is discounted at the risk-free rate. This does not imply that the methodology does risk-neutral valuation: the probabilities used to calculating the expectation of the future value of the option are p and $1 - p$, not their “risk-neutral” counterparts, q and $1 - q$.

Arnold and Crack provide three proofs for their formula, which are not presented here. A heuristic proof is given in the presentation of the valuation methodology used in this thesis, which is based on this formula and simulation. More about simulation methods for valuing options is given below.

Option pricing by simulation

Monte Carlo methods were developed for option pricing to deal with two main problems in lattice methods (Boyle 1977). Firstly, the use of lattices becomes computationally intensive as the number of underlying assets increases. Secondly, lattices are not well suited to deal with path-dependent options, e.g., options whose value depends on the highest or the average value of a stock in a certain time window, or other exotic instruments. Simulation-based methods have neither of these problems.

Option pricing by simulation uses the risk-neutral valuation result directly: the process involves the generation of thousands of sample paths for the evolution of the underlying asset as if it were earning the risk-free rate of return. Simulating sample paths of the

uncertain parameters this way is the equivalent of using probabilities q and $1 - q$ in a lattice. This simulation method is ideal for valuing path-dependent European options, i.e., options whose value at T depends on the entire evolution of the stock price up to that time. Finding the value of a European option, i.e., one that can only be exercised at its expiration, is straight-forward: for each simulated path, it involves determining the value of the option at the expiration time, then averaging out this value over all paths, and finally discounting this expectation at the risk-free rate. For details on this approach, see Hull (2000).

Pricing American options with simulation is somewhat more difficult. The reason is that the decision to exercise early (i.e., before expiration) is based on comparing the value of immediate exercise to the expected value of the option looking forward. Therefore, calculation must be recursive, proceeding backwards just as in the lattice approach; however, the simulation of paths proceeds forward, which means that simulation approaches do not provide immediate information about the conditional expected value of the underlying asset in the future. There are multiple categories of methods that attempt to overcome this difficulty; for representative methods see, e.g., Longstaff & Schwartz (2001), Andersen (2000), and Ibanez & Zapatero (2004). The method used in this thesis for the valuation of options is based on stratified state aggregation and the algorithms developed by Tilley (1993), Barraquand & Martineau (1995), and Rayman & Zwecher (1997).

Tilley (1993) was the first to introduce a simulation approach to valuing options on a single underlying asset with early exercise opportunities, such as American and Bermudan.² With Tilley’s (1993) algorithm, K paths for a single underlying asset s are simulated using risk-neutral dynamics; then they are grouped together in M bins with K/M paths in each bin for each time step. The paths in each bin are chosen to be adjacent in the value of the underlying asset, so effectively the grouping introduced a partitioning of the underlying asset space. The intrinsic value (immediate exercise) of the option for all the paths was then calculated for all paths in a bin m and compared to the holding (or “waiting”) value $H(m, t)$ for the respective bin at time t . The holding value was calculated as

$$H(m, t) = e^{-r_f \delta t} \frac{M}{K} \sum_{\substack{\text{all paths} \\ \text{in bin } m \\ \text{at time } t}} F(s_{t+\delta t})$$

The solution thus progressed backwards recursively. At expiration the option value was taken equal to its intrinsic value. One time step before, the option value along each path was calculated as the maximum of the intrinsic value of immediate exercise and the value of waiting, estimated above. Repeating this calculation for each bin returned the value of the option at that time for all paths. The process was repeated for all time steps and the value of the option along each path was calculated recursively.

²American options permit exercise at any time in a specified period; Bermudan permit exercise only at pre-determined points in time. An extreme Bermudan option is a European option, which allows exercise only at a single, pre-specified point.

The greatest shortcoming of Tilley’s (1993) algorithm is that it is not easily extended to multiple dimensions (e.g., options on the maximum of several underlying assets). Specifically, the partitioning of multi-dimensional underlying asset spaces was unclear in the original paper. Additional problems included a high estimator bias, because the same paths are used to estimate the optimal decisions and option value (Boyle, et al. 1997), even if a “sharp-boundary” variant is used, also proposed in Tilley (1993). Finally, the memory requirements with Tilley’s (1993) algorithm were initially too large given the computing power of the time, as all paths had to be stored for the calculation of expectation.

Barraquand & Martineau (1995) proposed an alternative method, by grouping paths along the option payoff space, not the underlying asset value space. The approach is known as Stratified State Aggregation along the Payoff (SSAP). In SSAP only a single-dimensional space needs to be partitioned, irrespective of the number of underlying variables. The payoff space is partitioned into M bins per time step in an initial simulation run of a few paths, typically around 100 to 1000. The definition of bins along the payoff does not change from then on. By simulating paths for the underlying assets one at a time, it is possible to calculate the transition probabilities from each bin at time t to each bin at time $t + \delta t$. This algorithm also proceeds with backward recursion: using the transition probabilities between bins, it is easy to calculate the expected continuation value of the option for each bin.

Figure 2-8 shows the transitions from a bin m at time t to the 5 bins at time $t + \delta t$ and their respective transition probabilities, $P_t(m, 1) \dots P_t(m, 5)$.

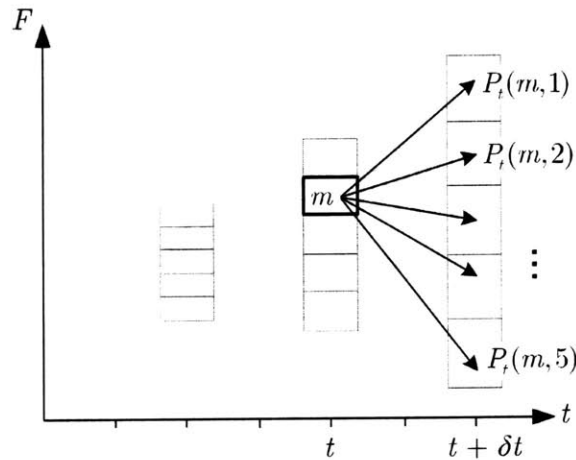

Figure 2-8: Bin definition and transition probabilities in SSAP algorithm

By aggregating along the payoff space, Barraquand & Martineau (1995) truly enabled the calculation of options on the maximum of multiple underlying assets. Moreover, the memory requirements for their algorithm are much smaller than with Tilley’s method, be-

cause only the transition probabilities need to be stored, not the entire paths. On the other hand, the error in the SSAP estimate cannot be bounded either from above or below. Finally, by aggregating on a single statistic, Barraquand & Martineau (1995) “lump together” very different events. For example, to value an option on the maximum of two underlying assets (s_1, s_2) with strike price X , SSAP would lump together two very different paths such as $(s_1, s_2) = (110, 110)$ and $(s_1, s_2) = (110, 50)$, because their payoff is identical: $(110 - X)$; however, as shown by Geltner et al. (1996) and Tan & Vetzal (1995), early exercise for the first pair is never optimal, whereas for the second it might be. Generally, the SSAP algorithm is unable of capturing disjoint exercise regions, and as a result under-estimates the value of the option in these cases (Broadie & Detemple 1997).

Rayman & Zwecher (1997) attempt to correct this problem by including two or more statistics in the definition of bins; e.g., in the two-asset example, they define bins based on the values of both assets. In the two-asset example their method effectively uses SSAP mechanics of bins and transition probabilities and the asset-based space state aggregation introduced by Tilley. In more underlying assets, there is a clear distinction between the number of statistics used for state aggregation and the number of assets. For example, for an option on the maximum of 5 underlying assets, an adequate second statistic is the second largest value of each path at each time. In this case, bins are defined along 2 dimensions even though the underlying asset space is 5-dimensional. The modification Rayman & Zwecher (1997) introduced to the SSAP algorithm is the basis for the algorithm developed for option valuation in this thesis.

2.7 Summary and research contribution

As described in Chapter 1, this research provides two engineering management tools: a technical methodology for screening dominant evolutions of a system, and an economic valuation tool for estimating the value of initial design decisions that enable such evolutions. With these two distinct but complementary tools, this research attempts to advance and integrate the two strands of literature on which it is based. The platform design literature is extended with a semi-quantitative tool for identifying standardization opportunities and platforms among variants with different functional requirements. The real options literature is extended with a methodology for mapping design and development decisions to structures of real options, and a simulation-based valuation algorithm designed to be close to current engineering practice and correct from an economics perspective. The important contribution of this work, however, lies in the joint use of these two complementary tools, as a way to obtain the value of an initial design that includes the flexibility it creates as a platform for the evolution of an entire system. Used jointly, these tools can greatly improve the economics of engineering program design, whilst deviating little from an engineering sensitivity analysis in terms of mechanics.

Chapter 3

Invariant Design Rules for platform identification

3.1 Introduction

This chapter develops the methodology for locating collections of components that can be standardized among system variants, given their different functional requirements, and exploring alternative collections of such components. In many systems, this problem is simple and is solved intuitively: the identification of the platform components emerges naturally from the historical evolution of multiple variants. Potential platforms are those systems that act as “buses” in some way (Yu & Goldberg 2003), or those that provide interfaces between other, customized systems. The identification of platforms is more difficult in network-like systems or systems in which platforms are comprised of subsystems and components from various levels of system aggregation. Platform identification is equally cumbersome in very large and complex systems, as the size of the combinatorial space of platform strategies is 2^n , where n is the number of distinct components or modules in the system (Siddique & Rosen 2001). The methodologies in this chapter are used to reduce significantly the size of this space by considering the physical and engineering constraints posed by the design specifications of the modules and the functional requirements of the system. In the context of designing flexibility in programs of multiple large-scale developments, the methodology introduced in this chapter is used for screening alternative standardization strategies that may be optimally implemented in the future.

The methodology introduced in this chapter starts with a formal representation of a system as a sensitivity-Design Structure Matrix (SDSM) at the parameter (variable) level. External functional requirements for the system are introduced to the SDSM next, and it is examined how changes in the functional requirements propagate through the design variables. Identification of platform (i.e., standardized) components among two or more systems is performed by starting from a design, i.e., a specific solution to the engineering problem, and prescribing local “insensitivities” between the design variables or module specifications.

The Invariant Design Rules (IDR) are sets of components whose design specifications are made insensitive to changes in the projects' functional requirements, so that they can be standardized and provide "rules" for the design of customized components. The customized subsystems can then be designed to accommodate differences in the functional requirements of the entire system, while the "invariant design rules" can be standardized. This concept is made operational with an algorithm for the identification of alternative collections of invariant design rules. Additionally, this chapter shows how representing a system as an SDSM at more than one level of system aggregation can improve the exploration of alternative standardization strategies. These methodologies enable an efficient search of the combinatorial space of different standardization strategies, and a dramatic reduction of the space of efficient platform strategies.

3.2 Related work

Existing methods achieve the exploration of the design space for platform strategies in two ways. One approach has been to characterize components using indices of how coupled they are to other components or how "exposed" they are to external changes (Suh 2005). A related approach has been to integrate the search for optimal platform partitioning with a platform/variant optimization problem.

The second approach involves modeling net profit (or cost) as a function of the design characteristics of variants, then maximizing profit (or minimizing cost) by changing the design variables that comprise the platform. For example, Fujita et al. (1999) formulate the platform selection problem as a 0-1 integer program coupled with the platform and variant optimization problem. Also, Simpson & D'Souza (2003) solve the problem of platform identification and optimization in a single stage using a multi-objective genetic algorithm, where part of the genome in the algorithm "decides" which variables are part of the platform and activates appropriate constraints. This approach requires an engineering system model as well as a model of the benefits of each platform strategy. Then, integrating the platform identification problem with the product family optimization problem is computationally intensive but fairly straight-forward. The applicability of these algorithms is limited by computational capabilities and the reliability of the system model, which is often unsatisfactory for large-scale systems. Furthermore, mapping the design variables to the benefits from a platform strategy requires multi-disciplinary input and is generally not straight-forward; see e.g., de Weck (2005).

Because of these two limitations of the "optimization" approach to platform identification, heuristic approaches have been developed. These rely on multi-disciplinary engineering expertise to circumvent the frequent lack of an engineering model and the potential benefits of alternative platform strategies. The methodology offered in this chapter falls into this category. Recent advances in this area can be found in Martin & Ishii (2002), who develop a tabular methodology for computing indices of the degree of coupling between components

in a system. These effectively determine how amenable to evolution each system component is. Suh (2005) develops this further by introducing indices for the increase in cost and complexity in a system design, required to respond to a change in specifications.

The methodologies introduced in this chapter rely on the idea of limiting change propagation through the design of elements in the system. The principle is that the design of platform modules must be “robust” to the changes in specifications between product variants, whilst the customized modules must be “flexible” (Fricke & Schultz 2005). The change propagates through the design of systems because of the complexity and coupling in the system components. Eckert et al. (2004) classify components as change propagators, multipliers or absorbers, depending on how much change in the design of the entire system is brought on by changes in their own specifications. In this paper, the concepts in Eckert et al. (2004) are used in the form of a design structure matrix.

3.2.1 The design structure matrix (DSM)

As a system representation tool, the DSM was invented by Steward (1981), even though some of the methods for organizing a DSM, particularly partitioning and tearing, were already known from the 1960’s in the chemical engineering literature; see, e.g., Sargent & Westerberg (1964) or Kehat & Shacham (1973). In the 1990s, DSM’s were developed further and used to assist design management; they provided a succinct way of modeling and re-structuring the flow of information in a design organization; see, e.g., Eppinger et al. (1994), Kusiak (1990), Gebala & Eppinger (1991), Kusiak & Larson (1994), Eppinger & Gulati (1996). In the last decade, the DSM methodology has been used extensively in system decomposition and integration studies. For an excellent review see Browning (2001).

DSM’s provide a structured methodology for representing systems and processes. The term DSM summarizes a variety of different uses of essentially the same structure, i.e., a square matrix where each row (and the respective column) corresponds to a single “element.” Interactions between elements are represented as “1” (or another mark, often “x”) in the off-diagonal entries of the matrix body. The off-diagonal entries of a DSM correspond to structures of information flow or physical links between systems: independent systems (or parallel tasks) are uncoupled in the DSM, i.e., involve no diagonal entries. Sequential tasks and one-way information flows are denoted with an asymmetric off-diagonal entry; fully coupled systems and bilateral information flows are represented with symmetrical off-diagonal entries (Figure 3-1).

Depending on what the elements represent, DSMs are referred to as “component- based,” “parameter- based,” “activity- based” or “team- based.” Interactions between components represent material or energy flows or even spatial relationships in a static system (Pimmler & Eppinger 1994). Interactions between parameters (variables) are used to denote their coupling in a system model: a symmetric interaction between two parameters means that they are coupled in a system of equations and need to be determined jointly; an asymmetric

Three configuration that characterise a system																														
Relationship	Parallel	Sequential	Coupled																											
Graph Representation																														
DSM Representation	<table border="1"> <tr><td></td><td>A</td><td>B</td></tr> <tr><td>A</td><td>X</td><td></td></tr> <tr><td>B</td><td></td><td>X</td></tr> </table>		A	B	A	X		B		X	<table border="1"> <tr><td></td><td>A</td><td>B</td></tr> <tr><td>A</td><td>X</td><td></td></tr> <tr><td>B</td><td>X</td><td>X</td></tr> </table>		A	B	A	X		B	X	X	<table border="1"> <tr><td></td><td>A</td><td>B</td></tr> <tr><td>A</td><td>X</td><td>X</td></tr> <tr><td>B</td><td>X</td><td>X</td></tr> </table>		A	B	A	X	X	B	X	X
	A	B																												
A	X																													
B		X																												
	A	B																												
A	X																													
B	X	X																												
	A	B																												
A	X	X																												
B	X	X																												

Figure 3-1: DSM configurations that characterize physical links or information flows

interaction means that one variable determines the other. Component- and parameter interactions do not carry any precedence information. On the other hand, interactions in activity-based DSMs represent precedence between tasks, therefore the order of the line items in the DSM corresponds to the order in which activities are performed. By the convention used in this thesis, chronological precedence of activity j over activity i is denoted by an “x” or “1” in position i, j .

Manipulation of an activity-based DSM involves sequencing, i.e., the process of re-arranging the elements of the matrix so that precedence relationships are placed below the diagonal and feedbacks are eliminated. Manipulation of a component-based DSM, i.e. the re-arrangement of its rows and columns, is geared to achieve clustering. A clustered DSM is arranged so that most interactions occur close to the diagonal. Figure 3-2 shows the original and clustered component-DSM for a climate control system (Browning 2001). Clustering allows the easy detection of components that constitute “modules” according to the criterion used for constructing the DSM (spatial relationship, information flow etc.). Table 3.1 shows common applications and analysis techniques for each of these types of DSMs.

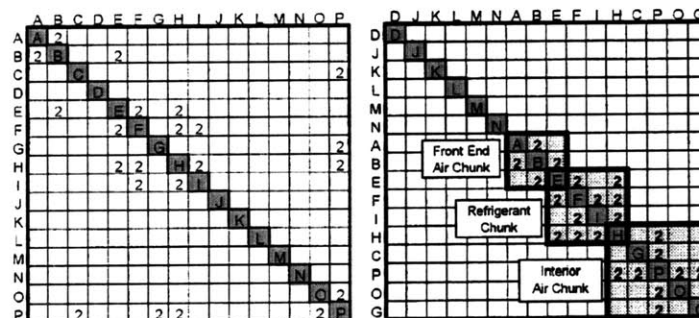

Figure 3-2: Original and clustered DSM (Browning 2001)

Eppinger & Salminen (2001) and Eppinger & Gulati (1996) discover mappings between component, activity and team-based DSMs, which implies that the four types of design

Table 3.1: DSM types, applications and analysis techniques

DSM Data Types	Representation	Application	Analysis
Component-based	Multi-component relationships	System architecting, engineering and design	Clustering
Team-based	Multi-team interface characteristics	Organizational design interface management, team integration	Clustering
Activity-based	Activity input/output relationships	Project scheduling, activity sequencing, cycle time reduction	Sequencing & Partitioning
Parameter-based	decision points and necessary precedents	Low level activity sequencing and process construction	Sequencing & Partitioning

structure matrices are linked and related. System components can be mapped to distinct line items in a work breakdown structure and are therefore treated as separate design activities. In turn, these design activities are often assigned to separate teams, so they are mapped to a team-based DSM. The relationship between a component-based and a parameter-based DSM is usually at the level of aggregation in describing a system. Consider for example a DSM representing the design of a system where each component is fully characterized by a single parameter. In this (idealized) case, the component-DSM and parameter-DSM for such a representation would coincide.

Recent research has extended the definition and scope of design structure matrices to include sensitivity between system elements. Eppinger et al. (1994) introduce numerical DSM's where the off-diagonal elements indicate the strength of dependence of one task on information produced by another task. This value could be extracted from an engineering task- or parameter-sensitivity analysis. They use these values to sequence and partition the DSM, as they are a metric of the portion of information produced during the first work iteration which will need to be changed during the second iteration. Yassine & Falkenburg (1999) described the concept of a sensitivity DSM as the change in output specifications of one task as a result of changes in those of another task, and linked the DSM methodology with Suh's Axiomatic Design principles (Suh 1990) for the purpose of managing tolerances and "slack" between specifications of design tasks. Guenov & Barker (2005) also develop a design decomposition and integration model in which Axiomatic Design matrices (AD) map functional requirements to design parameters while design structure matrices (DSM) provide structured representation of the system development context. They trace the logical and physical connectivity between architectural elements of the system to its functionality. Sullivan et al. (2001) also developed an extension of the DSM by including external (environmental) parameters, for the purpose of identifying invariable modules in software architecture given changes in the design requirements of other modules. The work by Sul-

livan et al. (2001) and Yassine & Falkenburg (1999) are the basis for the IDR methodology developed in this chapter.

3.3 Platform identification at the design variable level

All variants in a product family will have some commonality in the arrangement of components, their interactions, and their mapping between function and form (Martin & Ishii 2002). Variants in a product family thus share a platform architecture, i.e., a common “scheme by which the function of a product is allocated to physical components” (Ulrich & Eppinger 1999). This common architecture will most often be reflected in an identical system model between variants of a product line, i.e., an identical set of equations and variables that describe the system’s response. Given a common set of variables that describe the family architecture for each variant, it is possible to represent the architecture of all variants within a product line in a Design Structure Matrix (DSM).

3.3.1 sDSM system representation

Consider a system with κ design variables, so that its response and performance can be predicted using an engineering model and $\mathbf{x} = \{x_1, x_2, \dots, x_\kappa\}$. The corresponding variable-based DSM is the square matrix with κ rows and columns, whose entries i, j and j, i are equal to “1” (symbolically, $DSM(i, j) = DSM(j, i) = 1$) if the two variables i and j are coupled. In this sense, a variable-based DSM is an N^2 matrix, and represents the architecture of a system. Also consider a particular design variant for this system, i.e., a particular set of design variables, denoted as $\mathbf{x}^* = \{x_1^*, x_2^*, \dots, x_\kappa^*\}$. Since a DSM representation of the system corresponds to how its design variables are coupled, all variants will be mapped to the same parameter-based DSM that represents the system’s architecture.

A sensitivity-DSM (SDSM) can also be defined as a square matrix with κ rows and columns. The entry i, j of an SDSM represents the normalized sensitivity of parameter i to unit changes in parameter j in the neighborhood of the particular solution: $SDSM(i, j) = (\partial x_i^* / \partial x_j^*)(x_j^* / x_i^*)$, where the right-hand-side denotes total derivative, i.e., including constraint satisfaction. In other words, entry i, j represents the percent change in variable i caused by a percent change in variable j . Unlike the DSM representation of the system which is identical for all designs, the sDSM refers to a particular design, because it represents only the sensitivity between design variables. For this reason, a sensitivity DSM is always more sparsely populated than the corresponding variable-based DSM: a variable may depend on another variable, but its sensitivity to changes in the latter may be zero.

System or product variants exist to cover different commercial, marketing or societal needs and objectives that are completely exogenous to the system. E.g., exogenous factors for automotive design are the condition of the roads in the region a vehicle is marketed and the typical weather. Marketing studies can translate exogenous factors to functional

requirements, e.g., through processes such as QFD (ReVelle, et al. 1998). Functional requirements are performance or response targets the system has to meet, and as such they depend on both exogenous factors as well as the design variables of the system. Using the previous automotive example, a functional requirement affected both by the road quality as well as design variables is a measure of softness of a car's suspension system (e.g., settling response time and peak acceleration after driving over a bump). Let the functional requirements be denoted by a vector $\mathbf{FR} = \{FR_1, FR_2, \dots, FR_\xi\}$, where ξ is the total number of functional requirements for a system.

The SDSM can be extended to include the vector of these functional requirements (Figure 3-3). The south-western quadrant of the extended SDSM is populated by the sensitivities of design variables to exogenous parameters; the main body of the SDSM (south-east quadrant) contains the sensitivity of design variables to other design variables for the particular solution.

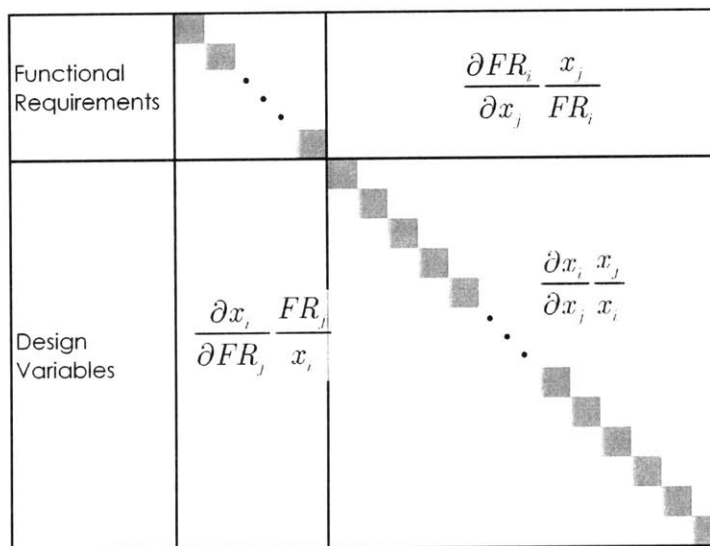

Figure 3-3: Normalized SDSM, extended to include exogenous functional requirements

3.3.2 Change propagation

Consider a particular solution $\mathbf{x}^* = \{x_1^*, x_2^*, \dots, x_\kappa^*\}$ to the system model, and a small change $\Delta\mathbf{FR}$ in some of the functional requirements \mathbf{FR}^* satisfied by this solution. To discover how change propagates through the system model, we ask the question:

What are the design variables that will need to change to facilitate this perturbation in \mathbf{FR}^ ?*

Assuming the system model behaves linearly for the changes in design variables necessary to achieve a perturbation $\Delta\mathbf{FR}$, each design variable x_i will need to change by Δx_i :

$$\Delta x_i = \sum_{j=1}^{\xi} \frac{\partial x_i^*}{\partial FR_j^*} \Delta FR_j^* + \sum_{j=1}^{\kappa} \frac{\partial x_i^*}{\partial x_j^*} \Delta x_j^* \quad (3.1)$$

This simply says that the required change in x_i is the cumulative change caused by all the functional requirements and other design variables to which x_i is sensitive in the neighborhood of x_i^* . If every term in the sums in equation 3.1 is zero, then Δx_i will also be zero. Writing this separately for each summation we obtain conditions 3.2 and 3.3.

$$\frac{\partial x_i}{\partial FR_j} \Delta FR_j = 0 \text{ for all } j = 1 \dots \xi \quad (3.2)$$

$$\frac{\partial x_i}{\partial x_j} \Delta x_j = 0 \text{ for all } j = 1 \dots \kappa \quad (3.3)$$

Conditions 3.2 and 3.3 indicate whether the change introduced in the functional requirements propagates to design variable x_i . A change can propagate to variable x_i because x_i directly depends on an affected functional requirement, or because x_i is sensitive to changes in some other variable that in turn is sensitive to changes. If both conditions 3.2 and 3.3 are satisfied for x_i , then the change does not propagate to variable x_i and therefore it can be common between the designs that satisfy functional requirements \mathbf{FR}^* and $\mathbf{FR}^* + \Delta \mathbf{FR}$. In other words, x_i can be a platform variable for these designs. Theoretically, conditions 3.2 and 3.3 are sufficient but not necessary: the sum of the terms in equation 3.1 can be zero without necessarily all the terms being zero.

3.3.3 Platform identification

A platform consists of all the design variables that are common between two designs, e.g., α and β , each of which is intended to satisfy different functional requirements. In other words, the problem is to find the partitioning of the design vector $\mathbf{x} = \{\mathbf{x}_p, \mathbf{x}_c\}$ that contains the greatest number of platform variables \mathbf{x}_p (and the least number of customized variables \mathbf{x}_c), given the functional requirements \mathbf{FR}^α and \mathbf{FR}^β . Given \mathbf{x}_p , the design variables of each variant can be written as in equation 3.5.

$$\mathbf{x}^\alpha = \{\mathbf{x}_p, \mathbf{x}_c^\alpha\} \quad (3.4)$$

$$\mathbf{x}^\beta = \{\mathbf{x}_p, \mathbf{x}_c^\beta\} \quad (3.5)$$

Consider a variant \mathbf{x}^* , and assume it shares the same platform components as α and β , so that $\mathbf{x}^* = \{\mathbf{x}_p, \mathbf{x}_c^*\}$. \mathbf{x}^* is essentially an unknown starting design point, from which variants are examined based on their differences in functional requirements according to the previous section.

Substituting $\Delta \mathbf{FR}$ between variants $*$ and α with $(FR_j^\alpha - FR_j^*)$, a design variable x_i may be a platform variable between \mathbf{x}^* and \mathbf{x}^α if

$$\left. \frac{\partial x_i}{\partial FR_j} \right|_{\mathbf{x}^*} (FR_j^\alpha - FR_j^*) = 0 \text{ for all } j = 1 \dots \xi \quad (3.6)$$

where $\cdot|_*$ denotes that the quantity is evaluated in the neighborhood signified by $*$.

If condition 3.2 applies as well between variants \mathbf{x}^* and \mathbf{x}^β ,

$$\left. \frac{\partial x_i}{\partial FR_j} \right|_* (FR_j^\beta - FR_j^*) = 0 \text{ for all } j = 1 \dots \xi \quad (3.7)$$

then variant \mathbf{x}^* can be operated under either functional requirements \mathbf{FR}^α or \mathbf{FR}^β , and design variable x_i^* will not be directly impacted by this change. This is shown by subtracting condition 3.7 from 3.6:

$$\left. \frac{\partial x_i}{\partial FR_j} \right|_* (FR_j^\beta - FR_j^\alpha) = 0 \text{ for all } j = 1 \dots \xi \quad (3.8)$$

Similarly, condition 3.3, written for design variable x_i , between variants \mathbf{x}^* and \mathbf{x}^β becomes

$$\left. \frac{\partial x_i}{\partial x_j} \right|_* (x_j^\beta - x_j^*) = 0 \text{ for all } j = 1 \dots \kappa \quad (3.9)$$

Written for design variable x_i , between variants \mathbf{x}^* and \mathbf{x}^α , condition (3) becomes

$$\left. \frac{\partial x_i}{\partial x_j} \right|_* (x_j^\alpha - x_j^*) = 0 \text{ for all } j = 1 \dots \kappa \quad (3.10)$$

Subtracting 3.10 from 3.9 yields the condition for insensitivity of variable x_i^* to changes in any other variable in the range $\mathbf{x}^\beta - \mathbf{x}^\alpha$:

$$\left. \frac{\partial x_i}{\partial x_j} \right|_* (x_j^\beta - x_j^\alpha) = 0 \text{ for all } j = 1 \dots \kappa \quad (3.11)$$

Together, equations 3.8 and 3.11 are the sufficient conditions for design variable x_i^* to be part of the shared platform between variants \mathbf{x}^* , \mathbf{x}^α and \mathbf{x}^β . For each j , condition 3.8 will be true if (a) $FR_j^\beta - FR_j^\alpha = 0$, i.e., functional requirement j does not change despite changes in exogenous factors, or (b) if the partial derivative $[\partial x_i / \partial FR_j]_*$ is zero. Therefore, platform components can only be sensitive to changes in functional requirements that are invariant to changes in exogenous factors. Likewise, condition (10) will be true for variable i if $x_j^\beta - x_j^\alpha = 0$ or $\partial x_i / \partial x_j|_* = 0$. Therefore, platform components can only be sensitive to unit changes in the design specifications of other platform components. Conditions 3.12 and 3.13 define the set of platform variables. Condition 3.12 says that all platform variables must be insensitive to changes in functional requirements between the variants considered. Condition 3.13 says that platform variables must be insensitive to customized variables for the variants considered.

$$\left. \frac{\partial x_p}{\partial FR_c} \right|_* = 0 \text{ for all } c, p \quad (3.12)$$

$$\left. \frac{\partial x_p}{\partial x_c} \right|_* = 0 \text{ for all } c, p \quad (3.13)$$

A sensitivity DSM of the variant \mathbf{x}^* can be partitioned to isolate the platform variables, as Figure 3-4 shows. The functional requirements that change between the variants are listed first, followed by the platform variables. Last are the customized design variables. Conditions 3.12 and 3.13 imply that the blocks East and West of the diagonal block of platform variables must be equal to zero ¹ by definition.

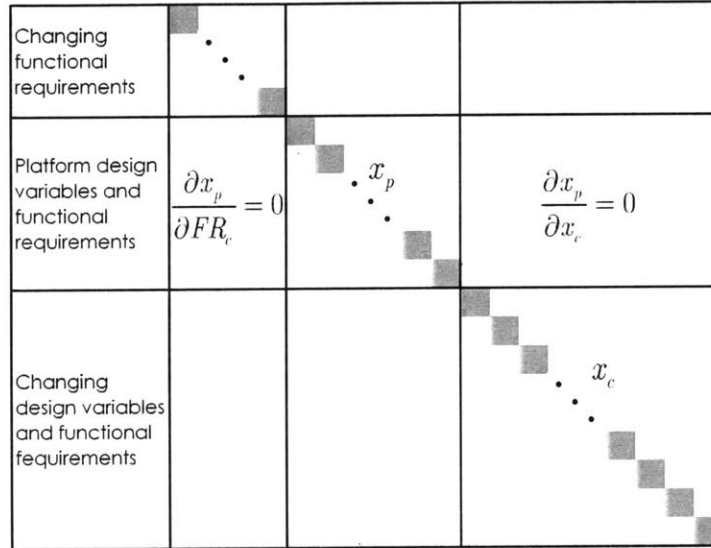

Figure 3-4: Invariant Design Rules on an S-DSM

The re-arrangement of the SDSM in Figure 3-4 shows why the platform variables provide the *Invariant Design Rules* for the variants in the product family. Design rules is the name coined by Baldwin & Clark (2000) to refer to the system components or variables that are established first in the design process and dictate the design of other components of variables. Therefore, design rules are unaffected by other variables, while at the same time they constrain the design of other variables. Platform components are thus *Design Rules* as the block on their East is zero and the block right below them, denoting sensitivity of the customized variables to platform variables, is generally non-zero. They are also *Invariant*, as the block on their West is zero and they are not affected by differences in functional requirements.

3.3.4 Algorithm for platform identification

This section presents an algorithm for the identification of the largest set of platform variables. The algorithm operates on the SDSM of Figure 3-4 and partitions it in such a way so that the blocks East and West of the block of platform variables are equal to zero within tolerance limits (Figure 3-4).

¹or almost zero, depending on the acceptable tolerance.

Conditions 3.8 and 3.11 or Equations 3.12 and 3.13 cannot be used directly for determining the platform variables between variants. If conditions 3.8 and 3.11 are satisfied, a design variable i is necessarily part of a platform between variants \mathbf{x}^α and \mathbf{x}^β . However, conditions 3.8 and 3.11 are only useful for checking whether a design variable belongs to the platform subset, not locating the platform subset. Also, Equations 3.12 and 3.13 hold for all platform and customized variables, but are not directly useful for determining what the partitioning of the design vector should be, given the sensitivity DSM at a solution \mathbf{x}^* and the functional requirements of the variants, \mathbf{FR}^α or \mathbf{FR}^β .

Table 3.2 describes the algorithm steps. The algorithm involves a running list Π_k (subscript k for iteration k) of variables, initially consisting of all elements of the SDSM that are directly insensitive to the changing functional requirements. By the end of the first loop (Step 2), Π_k contains the maximum possible number of platform variables. In this Π_k , it is very likely that some variables are sensitive to changes in customized variables (not in Π_k). On a second loop, each potential platform variable is examined and removed from Π_k if it is sensitive to a customized variable. The algorithm terminates when the IDR list remains unchanged, or if Π_k is empty.

Table 3.2: Algorithm for the partitioning of standardized DSM items

Step	Description	Variable stack
1	Establish running list of variables that are potential design rules	Π_k
2	Examine S-DSM element i . If i is not affected by changes in the changing functional requirements, then add element i to Π_k	
3	Repeat Step 2 for next element until all elements have been examined.	
4	Store running Π_k	Π_k contains maximum set of potential design rules
5	Check each element i against each element j . If $SDSM_{i,j} = 1$ and $x_i \in \Pi_k$ and $x_j \notin \Pi_k$ then remove element i from Π_k and go to Step 6. Otherwise, examine for next element $j = j + 1$	$\Pi_k = \Pi_k - \{x_i\}$
6	Repeat step 4 for next element i until all elements have been examined.	
7	If $\Pi_k = \Pi_{k-1}$ or $\Pi_k = \emptyset$ then the algorithm has converged; terminate. Otherwise, go to Step 4	

The algorithm in Table 3.2 is guaranteed to find the largest set of platform variables. To show this, it is enough to show that Π_k at iteration k always contains the largest set of platform variables \mathbf{x}_p . When the first loop is finished, at step 2, the running list Π_k indeed contains the largest \mathbf{x}_p . To show this, consider the complementary set to Π_k , $\bar{\Pi}_k$. $\bar{\Pi}_k$ contains all variables that do not satisfy condition 3.12. Since the variables in \mathbf{x}_p must satisfy both conditions 3.12 and 3.13, it follows that $\bar{\Pi}_k$ is the smallest possible set of platform variables; therefore, Π_k contains the largest possible set of platform variables. So,

$$\mathbf{x}_p \subset \Pi_k.$$

The second loop (steps 4-6) starts with $\bar{\Pi}_k$, and in every iteration k an element is removed so that $\Pi_k \subseteq \Pi_{k-1}$. Because in each iteration the element removed does not satisfy condition 3.13 it also follows that

$$\mathbf{x}_p \subseteq \Pi_k \subseteq \Pi_{k-1} \tag{3.14}$$

From Equation 3.14 it follows that the first feasible Π_k will be the largest set of platform variables.

3.4 Platform identification at higher system levels

The SDSM model can be extended to allow the IDR methodology to be applied at higher levels of system aggregation, not just at the design variable level. The problem with working with DSM's at the variable level is that they become very large as the scale and complexity of the system increases, and their tractability decreases. The concepts are illustrated with a simple example.

3.4.1 Activity SDSM representation

A variable-based DSM can be clustered so that subsystems and components are defined. Figure 4 shows an example of clustering a 45-variable DSM into 6 systems. The clustering of a DSM is not unique: drawing boundaries around sets of design variables and considering these sets as subsystems involves a trade-off. The larger the system definition, the fewer interactions are left outside the boundaries; the smaller the system definition, the more interactions exist between their variables and outside their boundaries. Similarly, variables can belong to two or more systems simultaneously so that these overlap, e.g., systems A and B in Figure 3-5. Alternatively, the common variables can be regarded as a separate "link" subsystem, interacting with both systems. See Sharman et al. (2002) and Yu & Goldberg (2003) for a discussion on clustering DSM's of subsystems and components. For this section, it is assumed that some clustering of the design variables into subsystems and components is known and acceptable.

Complex systems are seldom modeled, optimized and designed as a whole. There are usually disciplines responsible for the optimization, design and even commissioning of each

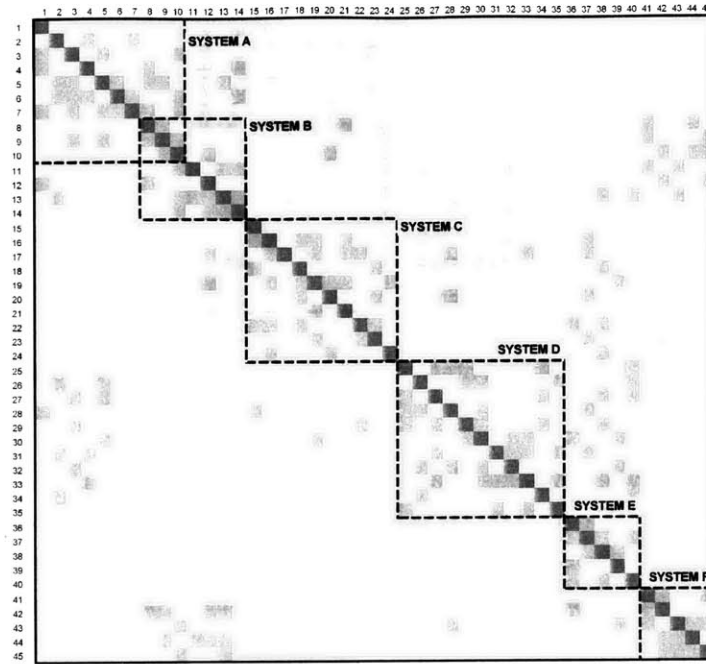

Figure 3-5: Clustering of a 45-variable DSM into 6 systems

subsystem. In other words, the design of each subsystem can be viewed as a design task which receives input specifications and produces output specifications concerning a specific set of physical components.

For example in Figure 3-5, design task C is the determination of variables 15 to 24, and requires knowledge of variables 12, 28, 33 and 36 to 39. These are the input specifications. The output specifications are the variables that are used for as inputs for other design tasks, i.e., 15 and 19 to 22. Optimization of the entire system involves the integration and agreement of the specifications to which each subsystem is designed to. Such formulations of the design optimization problem can be found in the multi-disciplinary optimization literature. At this point, it is assumed that the clustering of design variables corresponds to the design and development teams within the organization, so that each cluster represents a design task. Generally, the information flows between design activities (i.e., clusters), summarized in a subsystem-level DSM. Figure 3-6 shows the most important information flows between clusters in the DSM of Figure 3-5, assuming each cluster corresponds to an aggregate design activity.

Just as in the previous section, in order to formulate the sensitivity-DSM at the subsystem level, a specific solution to the system (i.e., a specific design) must be considered. Again, denote this as $\mathbf{x}^* = \{x_1^*, x_2^*, \dots, x_\kappa^*\}$, where $\kappa = 45$ in this example. An entry in the SDSM at the system level denotes the *necessary* change in the output specifications produced by a design task, given a change in its input specifications. For example in Figure

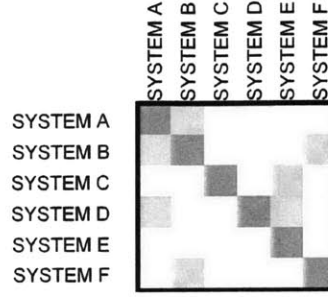

Figure 3-6: DSM representation of design activities at a system level

3-6, the full entry between systems C and E denotes that a change in some of the output specifications of system E (variables 36 to 39) incurs a necessary change in the output specifications of system C, given the specific design $\mathbf{x}^* = \{x_1^*, x_2^*, \dots, x_\kappa^*\}$. On the other hand, system C is shown to be insensitive to changes in systems B and D (i.e., variables 12, 28 and 33).

A more formal way to represent these sensitivities around a specific solution is by using the Jacobian matrix of derivatives between the output specifications of two design activities. For example, the Jacobian $J_{B,C}$ between the output specifications of design tasks B and C is written below. Notice that there is no reason to include in the Jacobian those variables that are “invisible” between systems.

$$J_{C,B} = \begin{bmatrix} \frac{\partial x_{15}}{\partial x_8} & \frac{\partial x_{15}}{\partial x_9} & \dots & \frac{\partial x_{15}}{\partial x_{14}} \\ \frac{\partial x_{19}}{\partial x_8} & \frac{\partial x_{19}}{\partial x_9} & \dots & \frac{\partial x_{19}}{\partial x_{14}} \\ \frac{\partial x_{20}}{\partial x_8} & \frac{\partial x_{20}}{\partial x_9} & \dots & \frac{\partial x_{20}}{\partial x_{14}} \\ \frac{\partial x_{21}}{\partial x_8} & \frac{\partial x_{21}}{\partial x_9} & \dots & \frac{\partial x_{21}}{\partial x_{14}} \\ \frac{\partial x_{22}}{\partial x_8} & \frac{\partial x_{22}}{\partial x_9} & \dots & \frac{\partial x_{22}}{\partial x_{14}} \end{bmatrix}$$

The only non-zero entries in this Jacobian will be the column $\left\{ \frac{\partial x_{15}}{\partial x_{12}}, \frac{\partial x_{19}}{\partial x_{12}}, \frac{\partial x_{20}}{\partial x_{12}}, \frac{\partial x_{21}}{\partial x_{12}}, \frac{\partial x_{22}}{\partial x_{12}} \right\}^T$, because only through variable 12 does activity B affect activity C. Assuming linearity in the response of each design task, the absolute change in the external specifications of task C because of changes in those of B is written as follows.

$$\Delta x_C = J_{C,B} \Delta x_B \Rightarrow \begin{bmatrix} \Delta x_{15} \\ \Delta x_{19} \\ \Delta x_{20} \\ \Delta x_{21} \\ \Delta x_{22} \end{bmatrix} = \begin{bmatrix} \frac{\partial x_{15}}{\partial x_8} & \frac{\partial x_{15}}{\partial x_9} & \dots & \frac{\partial x_{15}}{\partial x_{14}} \\ \frac{\partial x_{19}}{\partial x_8} & \frac{\partial x_{19}}{\partial x_9} & \dots & \frac{\partial x_{19}}{\partial x_{14}} \\ \frac{\partial x_{20}}{\partial x_8} & \frac{\partial x_{20}}{\partial x_9} & \dots & \frac{\partial x_{20}}{\partial x_{14}} \\ \frac{\partial x_{21}}{\partial x_8} & \frac{\partial x_{21}}{\partial x_9} & \dots & \frac{\partial x_{21}}{\partial x_{14}} \\ \frac{\partial x_{22}}{\partial x_8} & \frac{\partial x_{22}}{\partial x_9} & \dots & \frac{\partial x_{22}}{\partial x_{14}} \end{bmatrix} \begin{bmatrix} \Delta x_8 \\ \Delta x_9 \\ \vdots \\ \Delta x_{14} \end{bmatrix}$$

The Jacobian is just a mathematical representation of the sensitivity of the output specifications of a design task to changes in the output specifications of another task in the neighborhood of a particular solution. To use the IDR methodology at a qualitative

level for complex systems, it is necessary to have an aggregate metric for this sensitivity. This metric can be some norm of the Jacobian, e.g., this metric can be the element-wise Euclidean norm.² Then the S-DSM representation of the system for that specific solution can be a square matrix whose entries i, j are that norm of the Jacobian calculated at the specific solution \mathbf{x}^* .

$$SDSM_{C,B} = \|J_{C,B}^*\|$$

Nevertheless, even though it is useful to be able to express rigorously the entries of the SDSM at the component and subsystem level, this level of detail is not useful in practice. When using an activity-based SDSM, the design team should be prepared to abstract and estimate qualitatively the effect of changes in output specifications on other activities. Formulating the SDSM requires that the interaction in row i and column j be interpreted as "the change necessary to design activity i because of a unit change in activity j . In other words, if the design variables of component i are not (significantly) constraining those of component j in the neighborhood of the specific solution \mathbf{x}^* , then the entry i, j should be zero. Using this convention, the S-DSM can be a relatively small matrix representing and summarizing a design process of possibly thousands of design variables.

With this convention, all the concepts developed in the first part of this Chapter are transferable to component-based DSM's; the difference is limited to the way sensitivities are quantified. In the variable-based SDSM, sensitivity is objectively defined to be the relative change in one variable as a consequence of a change in another. In the component-based SDSM, sensitivity is subjectively defined as the change necessary in one component as a consequence of change in another. In other words, since components are described by many variables, designers should simply use judgment as to whether the design of a component influences the design of another.

3.4.2 Exogenous parameters and change propagation

As before, the SDSM of the design tasks can include functional requirements and characteristics. For example, for an automobile the functional characteristics or requirements can be passenger volume, cargo volume, towing capacity, fuel economy or acceleration. These functional requirements usually represent the value of the product system to the user or the buyer. Functional requirements are seldom mapped one-to-one to design variables. A system where such one-to-one mapping is possible is called an "uncoupled" design (Suh 1990). In most occasions, functional requirements will affect (and be determined as a function of) multiple design variables. In Figure 3-7 the functional requirements and aggregate design variables appear on the same DSM.

²This is denoted $\|\cdot\|$. For any matrix \mathbf{A} with elements A_{ij} , its Euclidean norm is $\|\mathbf{A}\| = \sum_{i,j} \sqrt{A_{ij}^2}$

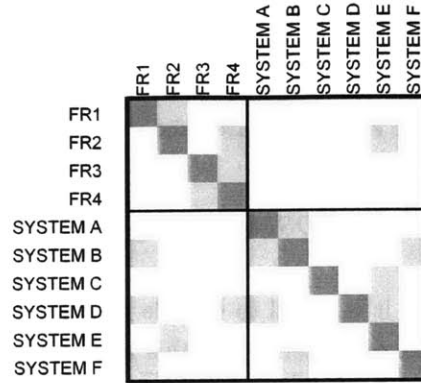

Figure 3-7: System-level DSM, extended to include functional requirements

The conditions that ensure that a design activity p can be common between variant systems are similar to equations 3.12 and 3.13

$$\begin{aligned} \|J_{p,c}^*\| &= 0 \quad \forall p, c \\ \|J_{p,j}^*\| \Delta FR_j &= 0 \quad \forall j \end{aligned}$$

where the index c denotes a customized activity. In words, platform design activities must be insensitive to changes in functional requirements between the variants considered. Also, platform variables must be insensitive to customized variables for the variants considered. For example, assume that FR1 is different between two or more variants. Applying the IDR algorithm to the SDSM in Figure 3-7 yields the following partitioning into changes, invariant design rules (platform systems) and customized systems (Figure 3-8). The Invariant Design Rules in this case, i.e., the platform components, are only C and E; system A is not, even though it is not directly affected by the changing functional requirement 1. This is because it is sensitive to design changes in system B, which *has* to change because it is directly sensitive to changes in FR1.

3.5 Exploration of platform strategies

The SDSM representation and the IDR methodology can be used to facilitate the exploration of different platform designs and strategies. The application of the IDR algorithm can be used at the variable or at the system/component level to indicate the system elements that do not need to change between two systems of similar architecture that are required to satisfy different functional requirements. Two extensions are presented in this section: (a) the effect of removing entries from the SDSM, and (b) the exploration of platform strategies at multiple levels of system aggregation simultaneously.

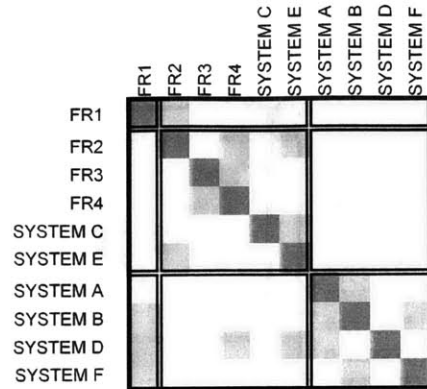

Figure 3-8: Invariant design rules for system-level DSM, given changes in FR1

3.5.1 Change absorbers and platform strategies

This section describes a process for the exploration of platform strategies, through the modification of the sensitivity entries in the SDSM. The reason that a change in a single functional requirement in the design of a system causes change in the design and specifications of a number of components or variables is the coupling between the system's elements, which is reflected in the entries of an SDSM. Therefore, exploration of alternative standardization strategies could be performed by removing sensitivities between components from the SDSM.

What is the effect of removing an entry from a component SDSM? Consider system B in Figure 3-7: its design requires information from both FR1, which happens to change between variants, and system F, which is a customized system. This means that the design of system B will also have to change between variants. System B could be designed to be insensitive to changes in FR1, even though this would not enable its standardization between variants. However, if it were possible to design system B so that its output specifications are indifferent to changes in both F and FR1, then it would be possible to standardize not only B, but also system A, as the design of A is only sensitive to changes in B. Prescribing that system B is insensitive to changes in system F and FR1 is achieved by removing the entry in row B and columns F and FR1. Running the IDR algorithm again shows the effect (Figure 3-9).

Alternatively, the coupling between systems A and B could be removed, so that the design of A is prescribed to be invariant to changes in the specifications of B. The effect is shown in Figure 3-10: system A can be standardized, while system B remains customized.

Finally, consider removing the sensitivity in the output specifications of systems B and F from the changing functional requirement, FR1. As Figure 3-11 shows, this would achieve the standardization of A, B and F, without requiring that system B is insensitive to changes in the design of system F.

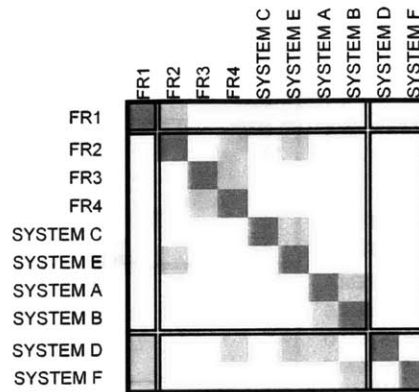

Figure 3-9: Effect of removing the sensitivity of B to FR1 and F

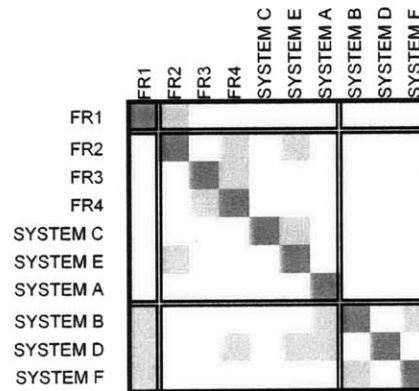

Figure 3-10: Effect of removing the sensitivity of A to B

This example shows that the removal of the sensitivity of system A to system B made it possible to standardize A; the removal of the sensitivity of B to both F and FR1 enabled the standardization of both A and B, but the removal of sensitivity of B to FR1 alone achieved nothing; finally, the removal of sensitivity of B and F from FR1 achieved the standardization of A, B and F as a cluster. This shows that there are many different ways to achieve standardization of specific components. To conclude which one is the best strategy, it is useful to examine exactly what it means to remove an entry from an SDSM.

Removing an entry i, j from an SDSM prescribes that there should be no need for information flow from design activity j to design activity i , when the outputs of j are slightly changed. This means that the design of i is required to be unconstrained by the outputs of activity j ; i.e., that the design of j has some slack. Such a slack can mean that system i needs to be over-designed, which in turn implies an economic penalty. For example, consider the design of an electric motor and the battery in a power tool as two coupled systems. If

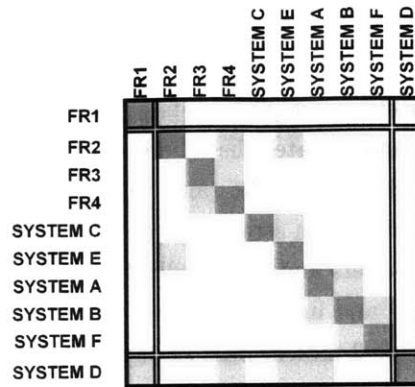

Figure 3-11: Effect of removing the sensitivity of systems F and B to FR1

the power requirement of the motor and the battery's capacity are determined together, so that each one is a constraint for the other, then the corresponding SDSM should have symmetrical entries in the corresponding rows and columns. Removing the entry in the row of the battery and the column of the motor implies that the battery is designed first, and its design drives the design of the motor. Therefore, the power requirement for the motor will be at most what the battery can provide; the battery will be generally oversized for the specific motor. Consequently, small variations in the power requirement of the motor do not affect the design of the battery. Effectively, such a design can accommodate different motors as long as they do not constrain the design of the battery. Over-sizing is only one way to technically remove SDSM sensitivities by intervening with the physical design. Another way is by *training modules*, e.g., using batteries in series. Yet another way, e.g., for physical dimensions or information, is by provisioning for interface components between coupled systems, so that the interface and at least one of the coupled systems are standardized, while the other is customized (Baldwin & Clark 2000). All these approaches to removing SDSM couplings imply that the design of a component is not constrained by the design of other components. In turn, this implies constraining the system away from its optimal design point, towards the interior of the feasible space and thus to suboptimal solutions. Therefore, the platform designer should remove as few sensitivities as possible.

On the other hand, removing entries enables the standardization of system components and the creation of platform strategies. In Figure 3-10, a single entry was removed, and this resulted in the standardization of one system; in Figure 3-9, two entries were removed which resulted in 2 systems standardized. Generally, not all platform strategies carry the same benefits, even if they involve the same number of standardized systems. The removal of entries should weigh the sub-optimality created by rendering two activities independent, against the benefits from designing more standardized components.

Figure 3-12 shows a plot of 100 standardization strategies, i.e., alternative combinations

of removed SDSM entries, applied to the system-level SDSM of Figure 3-8 ; the horizontal axis stands for the number of entries removed in each trial, against the total number of standardized elements (including functional requirements). Due to overlap, the points shown on the plot are only 19. The plot demonstrates that there are different combinations of SDSM entries that can be removed and result in the same number of standardized components. Each of these alternative standardization strategies contains useful information, as it leads the engineering team to create buffers and standardization opportunities by intervening at different places in a fully coupled and integral design.

Figure 3-12 shows just a simple 2-dimensional example of the search for platform strategies, where the number of SDSM entries removed must be minimized, and the number of standardized systems must be maximized. In this case, the points along the North-East Pareto frontier correspond to Pareto-optimal standardization strategies. The concept can be extended to the general case where platform benefits do not depend directly on the number of standardized components, but are a function of the standardized components between two or more systems. These benefits may be the reduction in implementation cost, design time and construction cycle for the second development as well as the operational efficiency in terms of maintenance and spare part inventory costs.

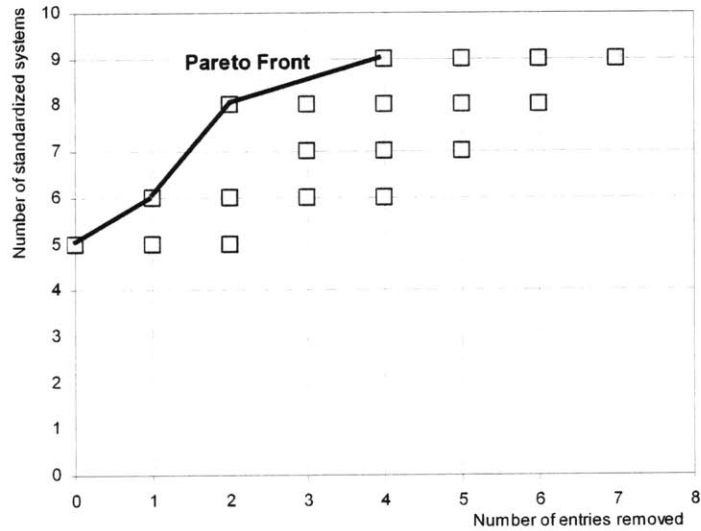

Figure 3-12: Removing SDSM entries: simulation results

3.6 Multi-level platforms

Fully standardizing or fully customizing an entire system may not always be the optimal standardization strategy. This section shows how the IDR methodology can be used it-

eratively in hierarchical systems to allow platform strategies at various levels of system aggregation. Consider system A in Figure 3-8, which is necessarily customized due to its close coupling with system B. If the design team has reasons to standardize system A, then it might be worth exploring at least its partial standardization.

Observe that the coupling of systems A and B makes it possible to decompose system A further into subsystems/components A1, A2 and A3, as shown in Figure 3-13 at the variable level. This decomposition may be evident in the physical architecture of system A, or it may require a change in the system’s architecture. The particular decomposition reveals the (1) the close coupling of component A3 with system B (which is not examined at a lower aggregation level), (2) the feedback of information from the design of system B to the design of system A2, and (3), the feed-forward of information from A1 to B. At the subsystem level SDSM, this effect is shown in Figure 3-14.

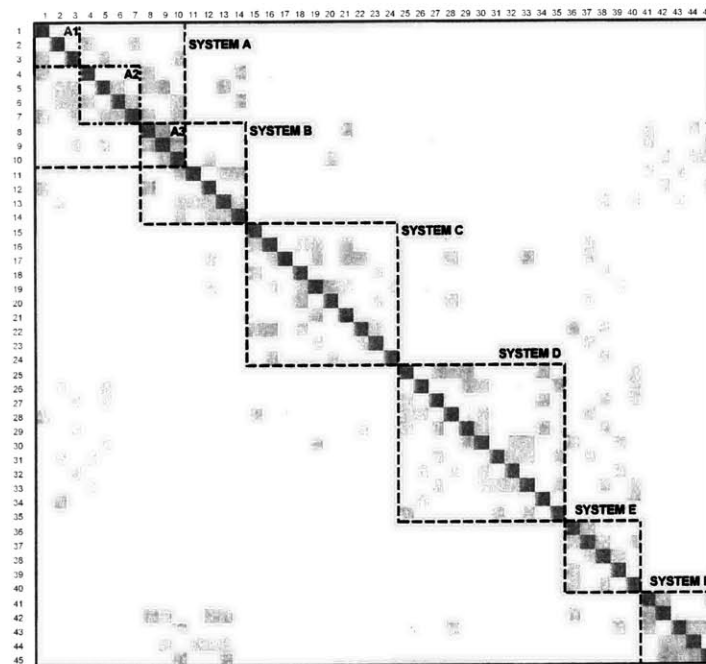

Figure 3-13: Decomposition of system A at the variable level

Applying the IDR algorithm to the SDSM in Figure 3-14 shows that “exploding” system A to subsystems enables its partial standardization (Figure 3-15). Indeed, subsystem A3 is now part of the platform, whereas A1 and A2 are customized between variants.

At this time, there is no systematic way to explore which subsystems should be exploded into their components. There are two approaches: as described above, a customized system whose potential benefit from standardization is large may be exploded to its components in case some can become part of the platform. The potential can be explored with the simulation methodology explained in the previous section. Similarly, a standardized system

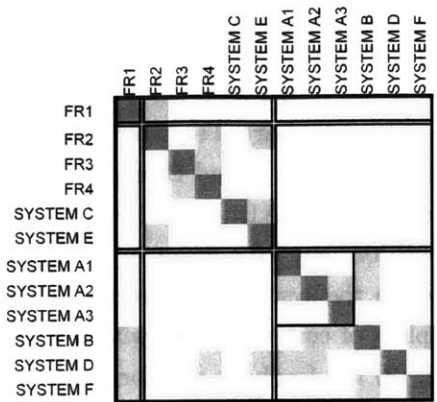

Figure 3-14: Decomposition of system A at the subsystem level

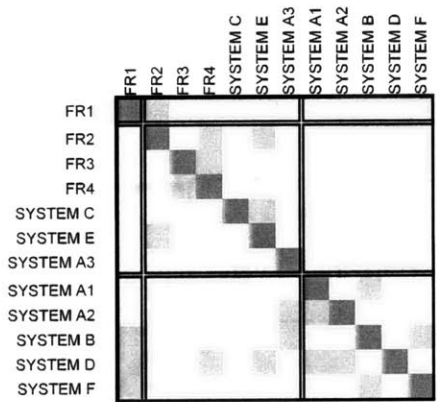

Figure 3-15: Re-partitioned SDSM, with platform that includes subsystem-level line items

may be investigated for components that can be customized, if this should greatly improve the performance of the system. However, these approaches require a fully quantified system and benefits model.

3.7 Summary

This chapter presented a novel methodology for the identification of the variables and components that do not need to change (i.e., platform variables and components), given a particular design and different functional requirements for variants in a product family. Next, this section introduced two methodologies for the exploration of alternative standardization opportunities and platform designs. One is based on simulation and requires an approximation model for the potential benefits and penalties of standardization strategies; the other is based on engineering judgment and enables the exploration of standardization

opportunities on various levels of system aggregation.

Chapter 4

Flexibility valuation in large-scale engineering programs

4.1 Introduction

A program's flexibility is captured in the developer's ability to defer design and development decisions until uncertainty unfolds and more information becomes available. Flexibility is also related with the developer's range of future choices. In a program of platform-based projects, the developer's flexibility was modeled as the choice of alternative standardization choices for the second and subsequent developments in the program. Chapter 3 introduced a methodology for screening alternative standardization strategies. Chapter 2 cited examples from the literature that demonstrate that this flexibility has value and should guide development decisions for the early stages of the program. This chapter shows how this value can be estimated.

The concept used for the valuation of flexibility is real options. The methodology originates from the financial economics literature in the 1970's, and there have been recent, mostly academic attempts to "import" it to the engineering valuation practice. These attempts have focused on case studies that demonstrate the concept and use of real options in the valuation and optimization of engineering systems. Applications include phased deployment of communication satellite constellations under demand uncertainty (de Weck et al. 2003); decisions on component commonality between two aircraft of the same family (Markish & Willcox 2003); building design under rent and space utilization uncertainty; e.g., see Zhao & Tseng (2003), Kalligeros & de Weck (2004), Greden & Glicksman (2004) and de Neufville et al. (2006). Despite these efforts however, the concepts and analytical tools have had very little traction with practitioners.

It is postulated that the slow penetration of the real options methodology can be attributed to two main reasons. Firstly, most of the engineering literature on flexibility and real options does not seem to agree on basic definitions and a single modeling approach. Often, flexibility is conceptualized as a collection of real options, (i.e., a right, but not an

obligation to change, expand, shrink or otherwise evolve a system) and this has had significant conceptual appeal to engineers. Indeed, the contribution of some of these case studies is in conceptualizing the real options associated with the engineering problem, without attempting to provide a rigorous option analysis. On the other hand, none of these applications provides a general, intuitive and consistent framework (or “language”) for modeling and communicating flexibility in engineering design.

The second reason for the slow penetration of real options in engineering practice is understood to be the attempt to transfer a “pure” and positive economic theory to the “production floor” of engineering design. When a rigorous options valuation is attempted in engineering applications, it usually runs into theoretical errors, practical difficulties in application, and logical arguments that convince neither engineering nor finance-oriented audiences. Adopting the theory requires a deep understanding of the assumptions behind it, which in turn, requires a level of economic literacy found in very few engineers. Even when the assumptions and techniques are understood, they often do not apply convincingly to the engineering problem at hand. And even when the assumptions are reasonable and the analysis is correct, the practical application requires conceptual leaps of faith (e.g., using the risk-free rate for discounting) and changes in well-established valuation practices within an organization. Experience has shown that improving the financial sophistication of engineering organizations has been slow and difficult.

In the context of this work, a useable methodology for flexibility valuation in an engineering management context is crucial. If the engineer is unable to estimate the flexibility value created by standardization (or any other technical innovation, for that matter), then they have no visible and quantifiable guidance to design for it. With this rationale, a novel real option valuation process is developed, that overcomes these impediments to the theory’s limited appeal in engineering. The proposed methodology deviates very little from current “sensitivity analysis,” practices in design evaluation. Firstly, a graphical language is introduced to communicate and map engineering decisions to real option structures and equations. These equations are then solved using a generalized, simulation-based methodology that uses real-world probability dynamics and invokes equilibrium, rather than no-arbitrage arguments for options pricing.

For the solution of these equations and the valuation of alternative design decisions, a novel simulation-based methodology is presented in Section 4.3. The algorithm is based on simulation and the stratified state aggregation techniques developed in the 1990’s by Tilley (1993), Barraquand & Martineau (1995), Rayman & Zwecher (1997), Broadie & Detemple (1997), Broadie & Glasserman (1997) and others. It involves a step process of simulating the exogenous uncertainties (in their real probability measure), valuing one “reference” design alternative per the organization’s practices, and finally, valuing the other design alternatives and options relative to the reference design, based on the organization’s inferred risk aversion and the system’s exposure to underlying risk. Certainty-equivalence arguments are used; risk-neutral dynamics are avoided. The implication of this approach is

that in some cases the proposed valuation methodology sacrifices economic rigor and some accuracy, specifically, the methodology is incorrect (from an economic viewpoint) in the valuation of partially correlated design alternatives or options on the maximum of several underlying assets. This sacrifice can be acceptable in the context of design and development if the valuation leads to an optimal design decision without necessarily a correct valuation. After all, the engineer's motivation to use the real options method is not to do valuation from the viewpoint of a diversified investor; it is to optimize and select among alternative designs.¹

Parking garage example As an example of the problems dealt with in this chapter, consider the design of a parking garage; see de Neufville et al. (2006). For simplicity, focus on the number of levels as the main design decision for the parking garage. Current engineering practice often involves building a garage with the optimal number of levels based on an expectation of the demand for parking. An alternative approach is to build a garage with fewer levels, but with reinforced columns that can support additional levels in the future. The value of the smaller building includes the value of flexibility (a) to choose how many levels to add to the existing garage in the future, and (b) to choose the timing of this expansion. Because the optimal expansion of the garage is contingent on unknown future events (e.g., the parking demand realized), any prior commitment to expand in the future is suboptimal. However, if the garage is designed based on a discounted-cash-flow value calculation, such commitment is automatically assumed. The design of the smaller garage, i.e., the decision on how many levels to build immediately and how many to be able to support in the future, should be based on the value of flexibility to expand the garage in the future. The methods presented in this chapter can be used to frame and solve problems such as the *valuation* of a garage design solution, considering the expansion flexibility that it enables. The *optimization* of the design is not discussed in this chapter. Because of its technical simplicity, this garage example will be used repeatedly in the text to clarify the concepts.

4.2 Design and development decisions

The managerial flexibility enabled by a particular design solution can be regarded for modeling purposes as strategic or operational (see Figure 2-6, p. 46). Strategic flexibility is usually taken to imply irreversible decisions, while operational flexibility often implies reversible actions with a non-trivial switching cost. This section demonstrates how common

¹Testing this "sacrifice" rigorously is outside the scope of this thesis. However, the design study in Chapter 5 compares the results from a risk-neutral valuation to the ones obtained with this methodology, and concludes that for the purposes of selecting design alternatives, the two approaches give the same results.

design and development decisions can be represented graphically as the exercise of strategic options and irreversible decisions. It is assumed that a single agent, the developer, has decision power over all current and future design or development decisions. It is also assumed that at that level, the developer's goal is to maximize present value or minimize the present value of cost of operations.

The general idea is to model alternative designs or phases of an engineering program as income-generating "states," and the transitions between states as the exercise of options. These transitions occur in two main stages: design and construction. Construction is modeled as the exercise of a call option on the difference in value between the target and departure states, with an exercise price equal to the construction cost. This is called a *timing option*, because it involves only the decision of when to begin construction and transition to another state. Design involves choosing between alternative target states, and it is modeled as the exercise of an option on the maximum of several underlying assets (a *choice option*): Each of the underlying assets to a choice option is a timing option leading to a target state. The total value of a state will be the sum of the value of its expected cash flows, plus the value of all the choice and timing options it enables. The next sections elaborate on these definitions of states, design and construction options.

4.2.1 Assets and states

A *state* represents the ownership and operation of a collection of assets, corresponding to a phase of program development. States describe a steady-state, business-as-usual situation, where minor, temporary and reversible interventions to a system's operation are used to maximize its performance; see Vollert (2003, p.23). The defining characteristic of the states in a model is that the transitions between them are irreversible, so their definition is a modeling decision. For example, the ownership and operation of 3, 4 and 5 oil production facilities in a certain region can be defined as three different states. It is assumed that these states are managed optimally, generating revenues that give them their intrinsic value. Graphically, states can be represented with a simple rectangle and a short description of the assets in operation.

A state can be modeled as a function that returns the free cash flow generated, given the design characteristics of the assets in that state and all the relevant information known to the organization at each time. For example, the monthly cash flows generated by a parking garage is a function of its capacity, the average monthly demand for parking there (in car-hours), the parking fees charged and the operating costs of the building. For more complex systems, the cash flows will depend on design variables and external information in much more complicated ways. However, assuming that cash flows per time period can be deterministic functions of the known design variables and uncertain factors, it is possible to write cash flows as $CF_u(\mathbf{s}_t)$, where u refers to a state and \mathbf{s}_t is a vector containing all relevant information at time t for determining the cash flow.

The value $V_u^{cf}(\mathbf{s}_0)$ as of t_0 of these expected cash flows can be written as the sum of the discounted future expectation of the revenues. Equation 4.1 represents the traditional discounted-cash-flow analysis (DCF) from time t_0 to an ad-hoc terminal time T , whereby the future cash flows from $t = t_0 \dots T$ are calculated based on the expected values of the uncertain parameters $E[\mathbf{s}_t]$ and then discounted back to the present time t_0 at a discount rate r , which depends on the risks in these expected cash flows.

$$V_u^{cf}(\mathbf{s}_0) = \sum_{t=t_0}^T e^{-rt} CF_u(E[\mathbf{s}_t]) \quad (4.1)$$

A more correct approach is to calculate the expected future cash flows in different scenarios of the uncertain parameters, and discount these expectations to the present time. Since the risk in the cash flows now depends explicitly on the design characteristics of state u , the discount rate is written as r_u to reflect this. The calculation, shown below, is known as the “expected present value (EPV).”

$$E \left[V_u^{cf}(\mathbf{s}_0) \right] = \sum_{t=t_0}^T e^{-r_u t} E[CF_u(\mathbf{s}_t)] \quad (4.2)$$

The two calculations will give different results if the function $CF_u(\mathbf{s}_t)$ is nonlinear in \mathbf{s}_t because of Jensen’s inequality (also known as the “flaw of averages”). This often happens when the state u incorporates (reversible) flexibility, in which case the function $CF_u(\mathbf{s}_t)$ is non-linear (Dixit & Pindyk 1994). For example, suppose that the vector \mathbf{s}_t is the cost of gas and oil used in a factory for heat generation (Kulatilaka 1993). If a factory has no flexibility to switch to the cheapest fuel at any time, then the value of the cash flows generated will be linear in \mathbf{s}_t . If a factory has such flexibility (e.g., because it owns a dual-fuel burner or two single-fuel burners with combined capacity larger than the peak demand), then the cash flows will be non-linear in \mathbf{s}_t . This is because e.g., when gas is adequately cheaper than oil, it will be optimal to produce energy using gas; the cost of energy will be a concave function of the cost of gas and therefore, free cash flows will be convex with the cost of gas. This non-linearity would cause the values calculated with the two methods not to agree. All but the simplest systems have such operational flexibilities, which means that Equation 4.2 should be used for their valuation. In practice, the value of assets is often calculated by considering the conventional DCF analysis (Equation 4.1) because it is a little simpler computationally, even though it is flawed in principle.

The factor $e^{-r_u t}$ represents an appropriate factor for discounting future cash flows generated from the operation of state u . In theory, this rate should match the risk in the cash flows in the nominator. In practice, these risks are considered ad-hoc to match the risk in the value of the entire holding firm, and the discount rate is chosen to be the firm’s weighted average cost of capital (WACC).

Finally, in practice, the value of these expected cash flows is considered to be the total value of the assets in a state. In reality, the value of these assets includes the value of

the real options to select and transition to other states by the design and development of additional assets. The next sections present the graphical convention and model for these decisions.

4.2.2 Decisions on timing

The ownership and operation of assets in a state may enable the transition to other states, through the expansion or exchange or re-configuration of existing assets or the acquisition of new ones. The option to transition from state u with value of expected cash flows V_u^{cf} to state w with value of expected cash flows V_w^{cf} at a transition cost C_{uw} is a call option on $V_w^{cf} - V_u^{cf}$ with a strike price C_{uw} . If we assume that the decision-maker makes the optimal choice between the transition and waiting for any value of the uncertain parameters \mathbf{s}_t , the value of this option at time t is the maximum of its immediate exercise or its expected value in the future.

$$F_{uw}(\mathbf{s}_t) = \max \left[[V_w(\mathbf{s}_t) - V_u(\mathbf{s}_t)] - C_{uw}, e^{-r_{uw}\delta t} E[F_{uw}(\mathbf{s}_{t+\delta t})] \right] \quad (4.3)$$

where δt is the time increment used for calculations and r_{uw} is an appropriate discount rate for the option's future expected value (continuously compounded). Timing options can be represented graphically as shown in Figure 4-1. If the option is not available over a period of time, but only instantaneously on a specific date, then it can be shown with a diamond instead of an arrow (Figure 4-2).

The total value of state u will include the intrinsic value of the income generated by the assets in that state, plus the value of the option value to transition to state w , so that

$$V_u = V_u^{cf} + F_{uw}$$

Parking garage example The owner of a 4-level parking garage whose columns can support up to 5 levels has the real option to expand the garage by building another level. Barring any specific constraints, this decision can be made at any time. The total value of the 4-level garage is the value of its future cash flows plus the value of the option to exchange the expected value of 4-levels and construction cost, to obtain the value of a 5-level garage. When developers decide to expand the building, the value of the transition option will be equal to the value of a 5-level garage less the construction cost of an additional level.

With this formulation, the exercise of a timing option implies an irreversible transition between states. To see this, suppose that at time t^* it is optimal to exercise the timing option and obtain state w . Then the total value of state u at t^* will be the value of state w net of construction costs:

$$\begin{aligned} V_u(\mathbf{s}_{t^*}) &= V_u^{cf}(\mathbf{s}_{t^*}) + F_{uw}(\mathbf{s}_{t^*}) \\ &= V_u^{cf}(\mathbf{s}_{t^*}) + V_w(\mathbf{s}_{t^*}) - V_u^{cf}(\mathbf{s}_{t^*}) - C_{uw} \\ &= V_w(\mathbf{s}_{t^*}) - C_{uw} \end{aligned}$$

If the option expires at T , its value then is

$$F_{uw}(\mathbf{s}_T) = \max [[V_w(\mathbf{s}_T) - V_u(\mathbf{s}_T)] - C_{uw}, 0]$$

Option expiration can happen in cases of concession periods for the development of land or natural resources (Brennan & Schwartz 1985). Often, option expiration is considered naturally, when the assets in states u or w die. However, in many cases, both states and these options are perpetual and the time horizon is used only to enable spreadsheet calculations.

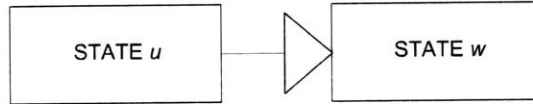

Figure 4-1: An American timing option to obtain state w from state u : transition can occur at any time within a time horizon.

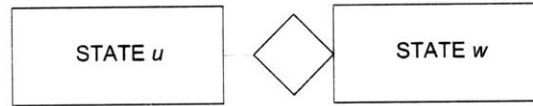

Figure 4-2: A European option to obtain state w from state u : transition can occur only at a specific time.

Time-to-build

Suppose the transition between states u and w is not instantaneous, but requires time-to-build t_{tb} , after which the entire construction cost C_{uw} is paid in full (Majd & Pindyck 1987). Equation 4.3 above can be modified so that the value of immediate exercise of the option, $I(\mathbf{s}_t)$, reflects this:

$$F_{uw}(\mathbf{s}_t) = \max [I(\mathbf{s}_t), e^{-r_{uw}t_{tb}} E[F_{uw}(\mathbf{s}_{t+t_{tb}})]] \quad (4.5)$$

where

$$I(\mathbf{s}_t) = e^{-r_w t_{tb}} E[V_w(\mathbf{s}_{t+t_{tb}})] - e^{-r_u t_{tb}} E[V_u(\mathbf{s}_{t+t_{tb}})] - e^{-r_f t_{tb}} C_{uw}$$

This assumes that the developer commits at time t to receive the value of state w at time $t + t_{tb}$, $V_w(\mathbf{s}_{t+t_{tb}})$, in exchange for the value of the cash flows in state u and the present value of the construction cost. Since the expected values of the states are uncertain, they are discounted at an appropriate rate. If the construction cost is considered certain and since the developer has committed to paying it, it can be discounted at the risk-free rate r_f .

The effect of a high t_{tb} is to reduce the value of the option, because of the difference in incomes foregone during the time to build. Such a time to build can be represented graphically as shown in Figure 4-3.

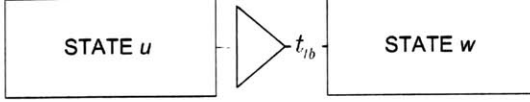

Figure 4-3: An American option with time-to-build t_{tb}

4.2.3 Decisions on target state

To model design decisions, the proposed approach uses *choice options*, i.e., options on the maximum of several underlying assets. The payoff of an option to obtain the maximum of $V_1(\mathbf{s}_t) \dots V_h(\mathbf{s}_t)$ at a respective cost $D_1(t) \dots D_h(t)$ is $\max_{i=1 \dots h} (V_i(\mathbf{s}_t) - D_i(t))$. Therefore, if the option does not need to be exercised immediately, its value at time t is the maximum of the payoff and the value of waiting. The value of waiting is the expected value of the option in the future, discounted at an appropriate rate r_{OR} :

$$OR(\mathbf{s}_t) = \max \left[\max_{i=1 \dots h} (V_i(\mathbf{s}_t) - D_i(t)), e^{-r_{OR}\delta t} E[OR(\mathbf{s}_{t+\delta t})] \right] \quad (4.6)$$

Choice options can be used to model design decisions, because design involves choosing between alternative engineering solutions, and locking-in with these solutions (e.g., by obtaining permits, securing contracts or other licences). In this work, the following conventions are used:

- The exercise of a choice option is irreversible.
- Whether alive or exercised, choice options do not affect the income generated by existing assets (therefore the intrinsic value of the current state).

The first convention may seem restrictive, but in practice it often is not. Design choices can often be considered irreversible, because the cost and time required are so large that repetition of the process is prohibitive. Nevertheless, if a design decision needs to be considered reversible, this is possible by stacking sequential choice options (see Section 4.2.4). Finally, Equation 4.6 can be easily extended to consider time lags in design as well.

Parking garage example The owner of a 3-level garage is modeled to have a choice option between expanding to either 4 or 5 levels. The owner may postpone the decision, which cannot be taken back once made. Deciding between 1 or 2 additional levels incurs design costs, but does not imply that these additional levels will be built; the developer obtains the timing option to build 1 or 2

additional levels, whichever was decided at the choice option. In other words, the exercise of a choice option does not imply a change in state. Graphically, this situation can be represented with the OR node as shown in Figure 4-4. The figure also shows how the owner of a 4-level garage does not have the choice option that the 3-level garage entails. Based on the above, the value of the 3-level garage $V_3(\mathbf{s}_t)$ is the sum of the value of future cash flows $V_3^{cf}(\mathbf{s}_t)$, plus the value of the choice option between expanding by one or two additional levels. Exercising the choice option obtains the timing options to construct the chosen design, $F_{34}(\mathbf{s}_t)$ and $F_{35}(\mathbf{s}_t)$.

$$\begin{aligned} V_3(\mathbf{s}_t) &= V_3^{cf}(\mathbf{s}_t) + OR(\mathbf{s}_t) \\ &= V_3^{cf}(\mathbf{s}_t) + \max [(F_{34}(\mathbf{s}_t) - D_{34}), (F_{35}(\mathbf{s}_t) - D_{35}), e^{-r_{OR}\delta t} E[OR(\mathbf{s}_{t+\delta t})]] \end{aligned} \quad (4.7)$$

Suppose that at time t^* , it was optimal to design one more additional level; the total value of the 3-level garage would become

$$\begin{aligned} V_3 &= V_3^{cf}(\mathbf{s}_{t^*}) + OR(\mathbf{s}_{t^*}) \\ &= V_3^{cf}(\mathbf{s}_{t^*}) + (F_{34}(\mathbf{s}_{t^*}) - D_{34}) \end{aligned} \quad (4.8)$$

i.e., the intrinsic value of its future cash flows plus the (net) value of the option to build one more level. If t^* was also the optimal time to exercise the timing option, then the total value of a 3-level garage would become

$$\begin{aligned} V_3 &= V_3^{cf}(\mathbf{s}_{t^*}) + (F_{34}(\mathbf{s}_{t^*}) - D_{34}) \\ &= V_3^{cf}(\mathbf{s}_{t^*}) + V_4(\mathbf{s}_{t^*}) - V_3^{cf}(\mathbf{s}_{t^*}) - C_{34} - D_{34} \\ &= V_4(\mathbf{s}_{t^*}) - C_{34} - D_{34} \end{aligned}$$

i.e., the value of a 4-level garage net of design and construction costs.

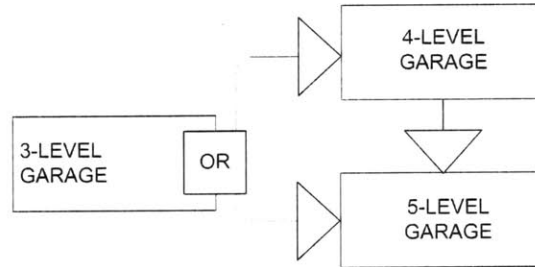

Figure 4-4: Choice between development options to 4- and 5-level garage

4.2.4 Complex design and development structures

With the convention introduced, choice and timing option can be combined to model a limitless variety of design and development decisions. The parking garage example is extended to illustrate how.

Parking garage example The structure of design and development decisions in Figure 4-5 encompasses much of the flexibility available in a typical project, in the context of the familiar parking garage. According to the model in Figure 4-4, the owner of a 3-level garage had the choice between designing a 4- or a 5-level garage. Suppose now there are more design choices, e.g., as to the material of the additional levels. The owner of 3 levels has the initial design decision of how many levels to add; if the choice is “2 more” then there is choice as to their material: they can both be concrete or both be steel. Each choice associated with a different construction time lag (TtB_{cc} and TtB_{ss}). If the optimal initial choice is “1 additional level,” then the second choice option (OR2) gives the developer a chance to change the decision to “2 additional levels.” If the developer decides in node OR2 to expand to a 4-level garage, they have the choice of material once again. A 4th floor out of concrete allows the subsequent choice (OR3) of the material of the 5th level (when it is built). A 4th floor of steel requires that the 5th level is also out of steel, but subjects the developer to, say, a possible change in legislation that will restrict the construction of more than one steel levels atop a concrete structure. This last uncertainty is shown using a circular “chance” node which assigns probabilities to its branches, much like in a decision tree. In Figure 4-5, the chance node serves to reduce the the value of the option to build a second steel floor is reduced by the probability the the legislation passes.

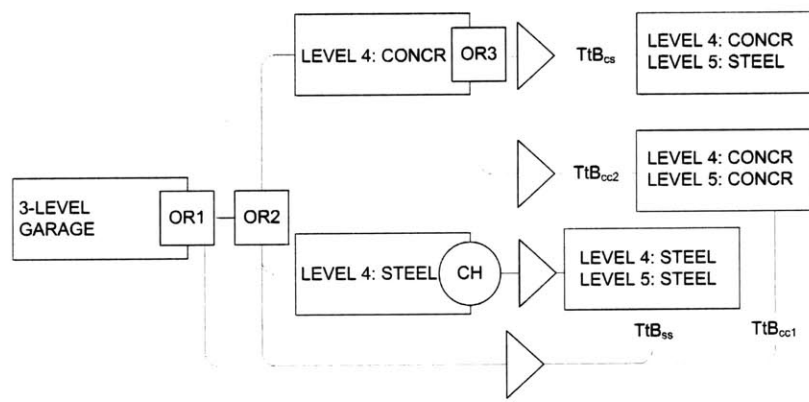

Figure 4-5: A complex structure of development decisions

4.3 Valuation

In the outset, it was postulated that the premise of existing valuation theory, i.e., the ability to hedge on the underlying asset and the lack of arbitrage, is part of the reason that the real options method has not gained traction with designers and developers. No-arbitrage

arguments enable the precise calculation of real options as pure derivative assets, when the underlying asset is actively traded, liquid and its value is observable. In all other cases, invoking no-arbitrage and using risk-neutral probabilities can be far-fetched, besides making the entire methodology unconvincing. This is the motivation for (yet) another solution methodology. The valuation methodology proposed in this chapter is designed to appeal to engineers by being conceptually close to current valuation and “sensitivity analysis” testing of design and development programs. To achieve this, we suggest compromising some of the theoretical rigor of “pure” real options analysis.

In the proposed methodology, a single *reference* state is valued using the developing organization’s standard practices. The reference state corresponds to the base case design, i.e., the solution the developer would consider before any discussion about flexibility. This valuation implicitly provides the organization’s risk tolerance towards the uncertainties s_i governing the system’s value. This risk tolerance is used for the valuation of alternative system designs (states) and options to reconfigure the system in the future (transitions between states). The valuation of options and states is achieved using an original simulation method which builds on the stratified state aggregation method along the payoff (SSAP) (Barraquand & Martineau 1995) and the Generalized Multi-Period Option Pricing model (Arnold & Crack 2003).

Figure 4-6 shows graphically the characterization of the proposed valuation scheme along four dimensions: state-space modeling, value dynamics modeling, decision rules and valuation. Monte-Carlo simulation is used to *model the state space*, as it is far more appealing to the engineering community than both lattices and continuous-time formulations. For the same reason, the proposed method involves *simulating the external uncertainties* to the engineering system and deduce the value of the system for a representative value of groups of simulation events; alternative approaches involve identifying a portfolio of securities that is believed to perfectly track the value of the system, or explicitly assuming the value of the system follows a Geometric Brownian Motion; e.g., see Copeland & Antikarov (2001). Both these alternatives may be reasonable and easily acceptable in financial asset valuation, but are often not convincing to the engineering community or imply absurd assumptions for many technical systems. The proposed method involves *recursive calculation of the decision rules* using stratified state aggregation (Barraquand & Martineau 1995). Alternative simulation approaches include the arbitrary specification of decision rules or their parametrization; e.g., see Longstaff & Schwartz (2001) or Andersen (2000). Finally, *valuation* is performed by discounting future values across alternative designs and options so that the price of risk is retained constant. This is achieved using the Generalized Multi-Period Option Pricing model (Arnold & Crack 2003), which avoids the need to simulate risk-neutral paths.

The methodology introduced in this chapter uses the state aggregation technique proposed by Rayman & Zwecher (1997), and applies it explicitly on the space of uncertain factors s . In other words, for N uncertain factors and M number of bins for each factor,

Modeling approach	Value dynamics	Decision rules	Valuation
Financial option modeling: sophistication, elegance, accuracy			
Continuous-time (Dixit & Pindyck 1994)	External tracking portfolio (Dixit & Pindyck 1994)	Exogenously defined decision rules / direct optimization (de Neufville 2002)	<u>Constant price of risk</u> <ul style="list-style-type: none"> Market defines price of risk for traded uncertainties Risk defined by the decision-maker for private uncertainties
Binomial lattice Finite differences (Cox, Ross and Rubinstein 1976)	<u>Value estimation from simulation of exogenous uncertain factors</u> (Copeland & Antikarov 2001)	Recursive, dynamic programming (Copeland & Antikarov 2001)	<u>Constant price of risk</u> <ul style="list-style-type: none"> Decision-maker defines price of risk Risk = standard deviation of return of underlying asset
<u>Simulation</u> (Barraquand & Martineau 1995, Raymar & Zwecher 1997)	<u>Simulation of evolution of value of one representative asset</u> (Copeland & Antikarov 2001)	Exercise boundary parameterization (Andersen 2000, Longstaff & Schwartz 2001)	Constant discounting (de Neufville 2002)
Real option modeling: ease of application, intuition, versatility			

Figure 4-6: Characterization of the proposed option valuation methodology (shaded boxes) and comparison with other valuation approaches.

the methodology proposes a grid of M^N , N -dimensional bins. These bins are defined for each time step with a small first-stage simulation of the uncertainty space. Rayman & Zwecher (1997) suggest 25 sample paths for each bin in this first stage simulation are adequate, and find that increasing the number of paths has a negligible effect on the results. For each time t , the bins are defined as hyper-cubes; e.g., for 2 uncertainties, Figure 4-7 shows a bin definition where the bin sizes increase exponentially.

The next step is to simulate a full set of K paths using their real-world (not risk-neutral) distributions for the uncertain factors, as described in Section 2.6.2. Rayman & Zwecher (1997) recommend $K = 500$ per bin. Next, for each time $t = t_0 + \delta t \dots T$ and for each bin $m = 1 \dots M$ it is possible to calculate

1. the average value for each uncertain factor in each bin \bar{s}_t^m , as

$$\bar{s}_t^m = \frac{1}{a_t(m)} \sum_{\substack{\text{all paths} \\ \text{in bin } m \\ \text{at time } t}} s_t^m$$

where s_t^m denotes a path in bin m at time t , and $a_t(m)$ is the total number of paths in bin m at time t . As the number of paths in bin m at time t increases, the average value \bar{s}_t^m will converge to a representative value for that bin. The rest of the analysis uses only these values \bar{s}_t^m to represent a bin (and not e.g., its bounds or paths in it, see Figure 4-7). For $t = t_0$, the bin specification is trivial: the factors are known with certainty and there is only one bin containing all paths, so $\bar{s}_t^m = s_0^m = s_0$.

2. the transition probabilities between all the bins at time t with all the bins at time $t + \delta t$. Denoting $b_t(m, n)$ the number of paths than fall in bin m at time t and bin n at time $t + \delta t$, the transition probability from bin m to n can be estimated as the (m, n) -element of a matrix P_t :

$$P_t(m, n) = b_t(m, n)/a_t(m)$$

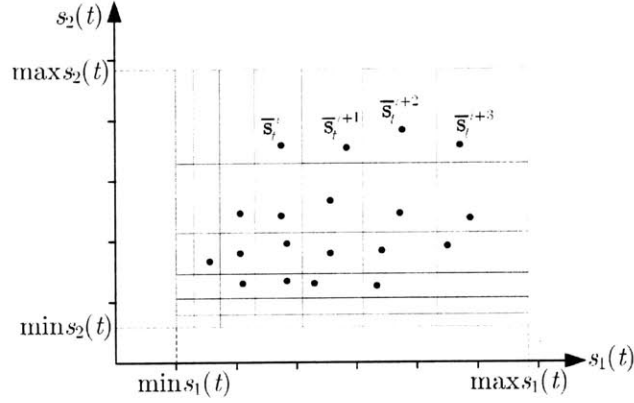

Figure 4-7: Two-dimensional bin definition and some representative values at time t

For calculating $a_t(m)$, $b_t(m, n)$ and \bar{s}_t^m , the paths do not need to be kept in memory. Since they are additive statistics, $a_t(m)$, $b_t(m, n)$ and \bar{s}_t^m can be updated as each simulated path is considered. After all paths have been accounted for, the final values of $a_t(m)$, $b_t(m, n)$ and \bar{s}_t^m are used to represent bins and to calculate the transition probabilities $P_t(m, n)$.

4.3.1 Calculation of conditional expectations

With these background calculations it is possible to estimate the conditional expectations on the space of uncertainties. For example, denoting $E[\mathbf{s}_{t+\delta t}; \mathbf{s}_t^m]$ the expected value of the uncertain factors $\mathbf{s}_{t+\delta t}$ conditional on the event that the value of the uncertain factors at t falls in bin m ,

$$E[\mathbf{s}_{t+\delta t}; \mathbf{s}_t^m] = \sum_n P_t(m, n) \bar{\mathbf{s}}_{t+\delta t}^n \quad (4.9)$$

Equation 4.9 can be used to estimate conditional expectations of future values or cash flows, such as the ones found in Equations 4.2, 4.3 and 4.6. For example, with this state aggregation scheme, the expected cash flows as of $t = t_0$ in Equation 4.2 can be estimated as

$$E[CF_u(\mathbf{s}_{t+\delta t}); \mathbf{s}_t^m] = \sum_n P_t(m, n) CF_u(\bar{\mathbf{s}}_{t+\delta t}^n)$$

From now on, $E_m[\mathbf{s}_{t+\delta t}]$ is taken to mean $E[\mathbf{s}_{t+\delta t}; \mathbf{s}_t^m]$ for brevity.

The calculation of the conditional expectation for more than one time steps into the future can be constructed directly from the definition of the transitional probabilities and Bayes' rule. Consider the conditional probability between \bar{s}_t^m and $\bar{s}_{t+2\delta t}^n$. The probabilities of reaching bin n from each bin at the previous time step (time $t + \delta t$) are contained in the n 'th column of $P_{t+\delta t}$. The probability of reaching the bins at $t + \delta t$ from bin m at time t corresponds to the m 'th row of P_t . Therefore, the probability of reaching $\bar{s}_{t+2\delta t}^n$ from \bar{s}_t^m is the (m, n) entry in $P_{t+\delta t}P_t$. Generally, the transition probability between \bar{s}_t^m and $\bar{s}_{t+j\delta t}^n$ where j is an integer is the (m, n) -element of the matrix $P_tP_{t+\delta t}\dots P_{t+(j-1)\delta t}$.

4.3.2 Valuation of a reference design

In contrast with the existing simulation algorithms described above, the proposed method involves simulation of the real-world dynamics of the underlying uncertainties \bar{s}_t , valuation of a reference design based on its expected future cash flows (Equation 4.2) excluding any flexibility, and estimation of the developer's implied price of risk for the uncertainty to which the reference design is exposed to. Consider a reference design, its corresponding state and an ad-hoc acceptable discount rate r_{ref} for this design. The value of this state V_{ref} as of time t_0 without any choice or timing options associated with it is given in Equation 4.2. Re-writing this for the representative values in bins, instead of the simulated paths, gives Equation 4.10.

$$V_{ref}(\mathbf{s}_0) = \sum_{t=t_0}^T e^{-r_{ref}t} E[CF_{ref}(\bar{s}_t)] \quad (4.10)$$

where the expectation is taken over all bins n at each time t . Alternatively, this value can be calculated recursively starting from $t = T$ and going backwards (equation 4.11). The recursive calculation is preferred over the previous one, because it yields the value of the reference design $V_{ref}(\bar{s}_t^m)$ for all $t = t_0 + \delta t \dots T$ and for all bins $m = 1 \dots M$.

$$V_{ref}(\bar{s}_t^m) = e^{-r_{ref}\delta t} E_m[V_{ref}(\bar{s}_{t+\delta t})] \quad (4.11)$$

Because of the uncertainty in future values, the discount rate for the reference case will also be equal to the risk-free rate at which the developer can lend money (e.g., by buying government bonds), plus a risk premium, which is assumed for simplicity to depend only on the reference design, so that

$$RP_{ref} = e^{r_{ref}\delta t} - e^{r_f\delta t}$$

The fact that the organization requires a risk premium for the uncertainty in the underlying factors means that there is an implicit "price of risk" for these uncertainties within the organization. If risk is measured in standard deviation of expected future returns, then the price of risk λ can be defined as the "required risk premium per unit of standard deviation of expected returns." For the valuation of the reference design, it can be calculated as

shown in Figure 4-8 and equation 4.12.

$$\lambda = \frac{e^{r_{ref}\delta t} - e^{r_f\delta t}}{\sigma_{ref}} \quad (4.12)$$

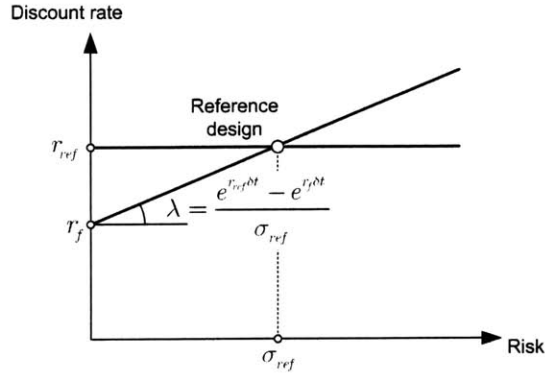

Figure 4-8: Inferred price of risk from reference design valuation

Although the price of risk is almost never explicitly discussed for the valuation of a design, most organizations are comfortable establishing a discount rate r_{ref} to compensate for the risks in the future expected values of $V_{ref}(\mathbf{s}_0)$. r_{ref} will often be the weighted-average cost of capital (WACC) of the firm, implying the assumption that the project corresponding to state u is representative of the entire firm in terms of risk exposure to the uncertainties \mathbf{s} . Although in theory this should make no difference in the valuation, we recommend the use of the first state in the development of a program as the reference state (e.g., state u in Figure 4-5). The reason is that the first state will probably represent a design the developer is more comfortable valuing, perhaps because of better technical knowledge.

4.3.3 Valuation of two perfectly correlated states

To value another state w , whose value is perfectly correlated with the reference design, the developer has two obvious choices for the discount rate: (a) they may use the reference discount rate r_{ref} , or (b) use the same price of risk. In practice, the firm-wide WACC is almost always used to value all designs. However, unless the reference state and state w have no differences in risk exposure to \mathbf{s}_t , using the WACC for both implies an inconsistency, i.e., that the developer is indifferent to the uncertainty in future values (see Figure 4-9). Suppose the standard deviation of changes in future values of design w are smaller than for the reference design. Using the reference discount rate for future values of w implies that the developer places no value in the difference in risk, $\sigma_{ref} - \sigma_w$, which is inconsistent with the fact that a risk premium RP_{ref} is demanded for the risk σ_{ref} , given that the reference design and w are perfectly correlated. In other words, if design w is traded in the market at a fixed price, set by other developers with the same risk tolerance (therefore the same λ),

then the developer will wrongfully not want to invest in w . Conversely, if w was riskier than the reference state, the developer using r_{ref} to value both will think w is a good design, when in fact it will not be. In conclusion, design w cannot be consistently valued using the reference discount rate r_{ref} .

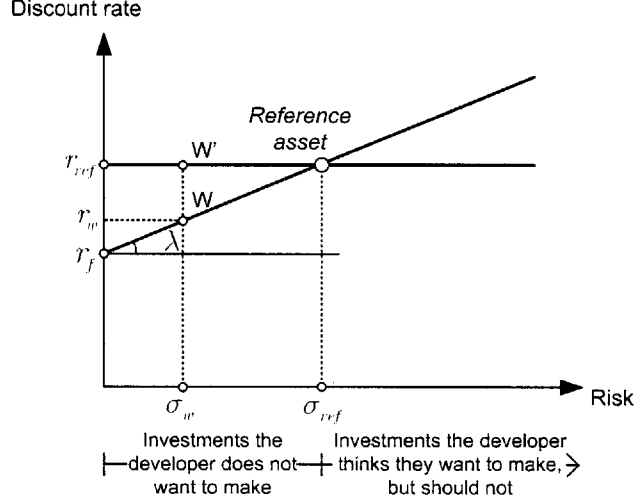

Figure 4-9: Risk and discount rate for design w

Therefore, w has to be valued at a discount rate $r_w \neq r_{ref}$, so that the price of risk in valuing both states is constant (for a discussion on this argument, see Section 4.4). The proposed methodology holds the price of risk λ constant, and uses certainty-equivalent valuation for all designs other than the reference one. The value of design w can be written as a certainty-equivalent as follows.

$$\begin{aligned}
 V_w(\mathbf{s}_t) &= e^{-r_w \delta t} E[V_w(\bar{\mathbf{s}}_{t+\delta t})] \\
 \Rightarrow (e^{r_w \delta t} + e^{r_f \delta t} - e^{r_f \delta t}) V_w(\mathbf{s}_t) &= E[V_w(\bar{\mathbf{s}}_{t+\delta t})] \\
 \Rightarrow (e^{r_w \delta t} - e^{r_f \delta t}) V_w(\mathbf{s}_t) + e^{r_f \delta t} V_w(\mathbf{s}_t) &= E[V_w(\bar{\mathbf{s}}_{t+\delta t})]
 \end{aligned}$$

which means

$$\begin{aligned}
 V_w(\mathbf{s}_t) &= e^{-r_f \delta t} [E[V_w(\bar{\mathbf{s}}_{t+\delta t})] - (e^{r_w \delta t} - e^{r_f \delta t}) V_w(\mathbf{s}_t)] \\
 &= e^{-r_f \delta t} \text{CEQ} [V_w(\bar{\mathbf{s}}_{t+\delta t})]
 \end{aligned} \tag{4.13}$$

Equation 4.13 shows that the same present value can be obtained either by discounting the real expected value at a rate that reflects the risk inherent in the expectation, or by reducing the future expected value by a certain amount that depends on its risk, and then discounting it at the risk-free rate. The value $\text{CEQ} [V_w(\bar{\mathbf{s}}_{t+\delta t})]$ is referred to as the certainty equivalent value and is equal to the expected future value $E[V_w(\bar{\mathbf{s}}_{t+\delta t})]$ minus a certain amount that corresponds to the risk in the expected value of design w . This amount is the required risk premium (which is unknown) times the actual value of w at time t , which

is also unknown. However, their product $(e^{r_w \delta t} - e^{r_f \delta t})V_w(\mathbf{s}_t)$ can be estimated as shown below. Holding the price of risk constant between the valuation of the reference design and w means

$$\lambda = \frac{e^{r_{ref} \delta t} - e^{r_f \delta t}}{\sigma_{ref}} = \frac{e^{r_w \delta t} - e^{r_f \delta t}}{\sigma_w}$$

It follows that

$$\begin{aligned} & \frac{e^{r_{ref} \delta t} - e^{r_f \delta t}}{\sigma_{ref}} = \frac{e^{r_w \delta t} - e^{r_f \delta t}}{\sigma_w} \\ \Rightarrow & \frac{e^{r_{ref} \delta t} - e^{r_f \delta t}}{\text{Std}\left[\frac{V_{ref}(\bar{\mathbf{s}}_{t+\delta t})}{V_{ref}(\bar{\mathbf{s}}_t)}\right]} = \frac{e^{r_w \delta t} - e^{r_f \delta t}}{\text{Std}\left[\frac{V_w(\bar{\mathbf{s}}_{t+\delta t})}{V_w(\bar{\mathbf{s}}_t)}\right]} \\ \Rightarrow & \frac{(e^{r_{ref} \delta t} - e^{r_f \delta t})V_{ref}(\bar{\mathbf{s}}_t)}{\text{Std}[V_{ref}(\bar{\mathbf{s}}_{t+\delta t})]} = \frac{(e^{r_w \delta t} - e^{r_f \delta t})V_w(\bar{\mathbf{s}}_t)}{\text{Std}[V_w(\bar{\mathbf{s}}_{t+\delta t})]} \end{aligned}$$

or,

$$(e^{r_w \delta t} - e^{r_f \delta t})V_w(\bar{\mathbf{s}}_t) = \frac{\text{Std}[V_w(\bar{\mathbf{s}}_{t+\delta t})]}{\text{Std}[V_{ref}(\bar{\mathbf{s}}_{t+\delta t})]} V_{ref}(\bar{\mathbf{s}}_t)(e^{r_{ref} \delta t} - e^{r_f \delta t}) \quad (4.14)$$

Substituting Equation 4.14 into 4.13 yields the value of w given the risk tolerance obtained from valuing the reference design:

$$V_w(\bar{\mathbf{s}}_t) = e^{-r_f \delta t} \left[E[V_w(\bar{\mathbf{s}}_{t+\delta t})] - (e^{r_{ref} \delta t} - e^{r_f \delta t})V_{ref}(\bar{\mathbf{s}}_t^m) \frac{\text{Std}[V_w(\bar{\mathbf{s}}_{t+\delta t})]}{\text{Std}[V_{ref}(\bar{\mathbf{s}}_{t+\delta t})]} \right] \quad (4.15)$$

Equation 4.15 can be used directly with the state aggregation scheme described in the previous section for the recursive valuation of design w . For each bin m at time t , the expected value of w in the next time step over all the bins n in time step $t + \delta t$ is shown in Equation 4.16. The standard deviation of $V_w(\bar{\mathbf{s}}_{t+\delta t})$ given $V_w(\bar{\mathbf{s}}_t^m)$ is denoted $\text{Std}_m[V_w(\bar{\mathbf{s}}_{t+\delta t})]$ and is calculated easily in Equation 4.17.

$$E[V_w(\bar{\mathbf{s}}_{t+\delta t})] = \sum_n P_t(m, n) V_w(\bar{\mathbf{s}}_{t+\delta t}^n) \quad (4.16)$$

$$\begin{aligned} \text{Std}_m[V_w(\bar{\mathbf{s}}_{t+\delta t})] &= \sqrt{E[V_w(\bar{\mathbf{s}}_{t+\delta t})^2] - E[V_w(\bar{\mathbf{s}}_{t+\delta t})]^2} \\ &= \sqrt{\sum_n P_t(m, n) V_w(\bar{\mathbf{s}}_{t+\delta t}^n)^2 - \left(\sum_n P_t(m, n) V_w(\bar{\mathbf{s}}_{t+\delta t}^n) \right)^2} \end{aligned} \quad (4.17)$$

4.3.4 Valuation of timing options

The value of a timing option to obtain state w in exchange for the value of u and the development cost is perfectly correlated with the difference $V_w(\bar{\mathbf{s}}_t) - V_u(\bar{\mathbf{s}}_t)$, if u and w are perfectly correlated. Therefore, if the two states u and w are perfectly correlated between them then the analysis in the previous section applies and the value of holding the option alive can be estimated recursively using Equations 4.15, 4.16 and 4.17. Ideally, the reference design should be the option's underlying asset, i.e., $V_w(\bar{\mathbf{s}}_t) - V_u(\bar{\mathbf{s}}_t)$; however, the appropriate discount rate for valuing this difference will not be known normally. On the other hand, if the two states are perfectly correlated, either one can be used as a reference case. Moreover, if they are both perfectly correlated with another reference state V_{ref} , then that value can

be used as a reference. So generally, the value of holding the option in bin m at time t is estimated as

$$H(\bar{\mathbf{s}}_t^m) = e^{-r_f \delta t} \left[E_m[F_{uw}(\bar{\mathbf{s}}_{t+\delta t})] - (e^{r_{ref} \delta t} - e^{r_f \delta t}) V_{ref}(\bar{\mathbf{s}}_t^m) \frac{\text{Std}[F_{uw}(\bar{\mathbf{s}}_{t+\delta t})]}{\text{Std}[V_{ref}(\bar{\mathbf{s}}_{t+\delta t})]} \right] \quad (4.18)$$

The value of the timing option for each bin m at time t will be $F_{uw}(\bar{\mathbf{s}}_t^m) = \max[H(\bar{\mathbf{s}}_t^m), I(\bar{\mathbf{s}}_t^m)]$, where $I(\bar{\mathbf{s}}_t^m)$ is the value of immediate exercise, $I(\bar{\mathbf{s}}_t^m) = [V_w(\bar{\mathbf{s}}_t^m) - V_u(\bar{\mathbf{s}}_t^m)] - C_{uw}$, assuming that the time to build is zero. Extension to longer construction times is straight-forward, given Equation 4.5 and the calculation of multi-period conditional probabilities in Section 4.3.1. The optimal exercise region of the timing option is defined by regions in the $(s_1, s_2, \dots, s_N, t)$ space in which it is optimal to exercise the option. It can be approximated by the discrete set of points $\bar{\mathbf{s}}_t^m$, $m = 1 \dots M$, $t = 0 \dots T$ for which $I(\bar{\mathbf{s}}_t^m) > H(\bar{\mathbf{s}}_t^m)$.

4.3.5 Valuation of choice options

Choice options are generally options on the maximum of several underlying assets. In the context of the decision model developed here, these alternative assets are the timing options to exchange state u for one of a set of h alternative states. These timing options are denoted F_{u1}, \dots, F_{uh} , with respective strike prices (construction cost) C_{u1}, \dots, C_{uh} . The choice option to obtain each of these timing options will generally have a strike price D_{u1}, \dots, D_{uh} , representing the cost to design each of the h assets. Assuming negligible design time lag, the general expression for the choice option is the maximum of immediate exercise, $I(\bar{\mathbf{s}}_t^m)$ and holding the choice option alive, $H(\bar{\mathbf{s}}_t^m)$. The value of immediate exercise is

$$I = \max[(F_1(\mathbf{s}_t) - D_{u1}), \dots, (F_{uh}(\mathbf{s}_t) - D_{uh})]$$

and the value of holding the option alive is given by Equation 4.18 above. As before, the value of holding the choice option is estimated in every bin m at time t by calculating its expected value at $t + \delta t$ over all bins at that time, subtracting the dollar risk premium, and discounting at the risk-free rate (equations 4.15, 4.16 and 4.17). If all underlying options F_{u1}, \dots, F_{uh} are perfectly correlated, then any one of them can be used as a reference valuation. Moreover, if they are in turn correlated with V_{ref} , then V_{ref} can be used directly.

4.4 Methodology performance and discussion

The previous sections addressed the modest penetration of the real options method in engineering design and development decisions. It was postulated that two impediments have been a common communication language for real options and a valuation methodology that is approachable by engineering and technology practitioners. Section 4.2 presents a graphical language for describing design decisions and mapping them to real option structures. Section 4.3 presents a novel algorithm for the valuation of alternative designs and options.

This section reviews and discusses the potential success these contributions might have in enabling real options thinking and analysis in engineering design. The discussion starts with the framework's versatility in modeling diverse design and development problems. Next, the novel numerical algorithm developed for the valuation of these options is tested against published results. Finally, the limitations are discussed for the proposed engineering option valuation methodology from an economics perspective.

4.4.1 Design decisions modeling

The purpose of the design and development decisions modeling approach introduced in Section 4.2 is to enable the structured thinking and communication of strategic flexibility that can be designed into a system. The graphical methodology introduced conveys a lot of information on design/development decisions and flexibility, and can be rigorously transferred in a quantitative model using Equations 4.2, 4.3 and 4.6. At the same time, it is versatile in modeling diverse engineering design situations.

On the other hand, this graphical representation of design and development flexibility has drawbacks. Firstly, it is impractical when too many discrete choices are present, leading to distinct states and designs downstream. Secondly, even though the representation tool and the equations behind it do not require homogeneous time formulations, they do require that no strong path dependency between states exists. Specifically, states must represent steady-state operation of a system; operation and cash flows may depend on time explicitly, but may not depend on the timing of decisions, transitions or actions in other states. A possible extension to the representation (and formulation of the state equations) could include additional endogenous state variables with deterministic transitions between time steps, but this is not considered in this thesis.

4.4.2 Algorithm Performance

Equation 4.15 for the valuation of perfectly correlated assets, such as a call option and its underlying stock, predicts that the value of the option should be the same regardless of the growth rate of the reference (underlying) asset. Moreover, according to the model, this value should be equal to the value obtained with risk-neutral valuation, i.e., if it is assumed that the underlying asset grows at the risk-free rate. The performance of the proposed option valuation algorithm is examined based on how well it approximates this value in the case of plain vanilla options on a single underlying asset.

To value plain vanilla options, equation 4.18 is re-written considering $V_{ref} \equiv V_w \equiv s_t$ and $V_u \equiv 0$. Thus the value of an American call option will be $F_c(\bar{s}_t^m) = \max[I_c(\bar{s}_t^m), H(\bar{s}_t^m)]$ and the value of a put option will be $F_p(\bar{s}_t^m) = \max[I_p(\bar{s}_t^m), H(\bar{s}_t^m)]$, where I_c, I_p are the intrinsic values of the options with strike price C in bin m ,

$$I_c(\bar{s}_t^m) = \bar{s}_t^m - C$$

$$I_p(\bar{s}_t^m) = C - \bar{s}_t^m$$

The holding value of both the call and the put is written as

$$H(\bar{s}_t^m) = e^{-r_f \delta t} \left[\frac{E[F(\bar{s}_{t+\delta t})]}{m} - \bar{s}_t^m (e^{r_s \delta t} - e^{r_f \delta t}) \frac{\text{Std}[F(\bar{s}_{t+\delta t})]}{m} \frac{\text{Std}[\bar{s}_{t+\delta t}]}{m} \right] \quad (4.19)$$

Figures 4-10, 4-12, 4-11 and 4-13 show the value of American calls for various strike prices, time to expiration and annual volatility of the underlying asset.² The error bars in all figures show a range of two standard deviations of the calculated value over 30 runs. In each run, $K = 100,000$ paths and $M = 200$ bins were used. The benchmark option value is obtained using binomial trees with the same number of steps as the simulation method, and Richardson extrapolation to $dt = 0$. The results obtained show that the valuation error in the proposed methodology is small and comparable to the error obtained using SSAP. Moreover, the standard deviation of the errors remains fairly constant as the growth rate of the underlying asset increases.

4.4.3 Valuation of uncorrelated states

The proposed valuation methodology and algorithm combines the versatility and power of simulation with recent theoretical results that enable the valuation of options using real world probability distributions. The potential value of such a method was discussed above: it involves communicating the concepts of real options analysis more efficiently and to a wider audience; it allows the use of simulation just like it is being used in current engineering practice; and it has the potential of improving the current practice of valuing engineering designs because it introduces the concept of accounting for risk. On the other hand, the valuation methodology is inaccurate and incorrect from an economics perspective when alternative designs and states are not perfectly correlated. The goal of this section is to examine how this methodology compares from a theoretical perspective with variations of classical real options analysis, as reviewed in Borison (2003).

The goal of this analysis was to value alternative designs (states) and options consistently according to their relative risk. To do so, the analysis postulated that the expected returns to all assets and options (therefore their discount rate) should lie on a straight line in $r \times \sigma$ space. From a Capital Asset Pricing Model (CAPM) perspective, this is a justified assumption if all states are perfectly correlated, because then the ratio of standard deviation of returns for different assets is equal to the ratio of their “betas” with the reference state. Trivially, this is also satisfied if there is only a single uncertain factor. If the states are perfectly correlated, the timing options are valued consistently, as their payoff (i.e., the difference between the values of two states) will be perfectly correlated with the reference state. Choice options are also valued consistently, as their payoff (i.e., the value of the

²These option characteristics are the same used in the tests Barraquand & Martineau (1995) performed on SSAP for comparison purposes.

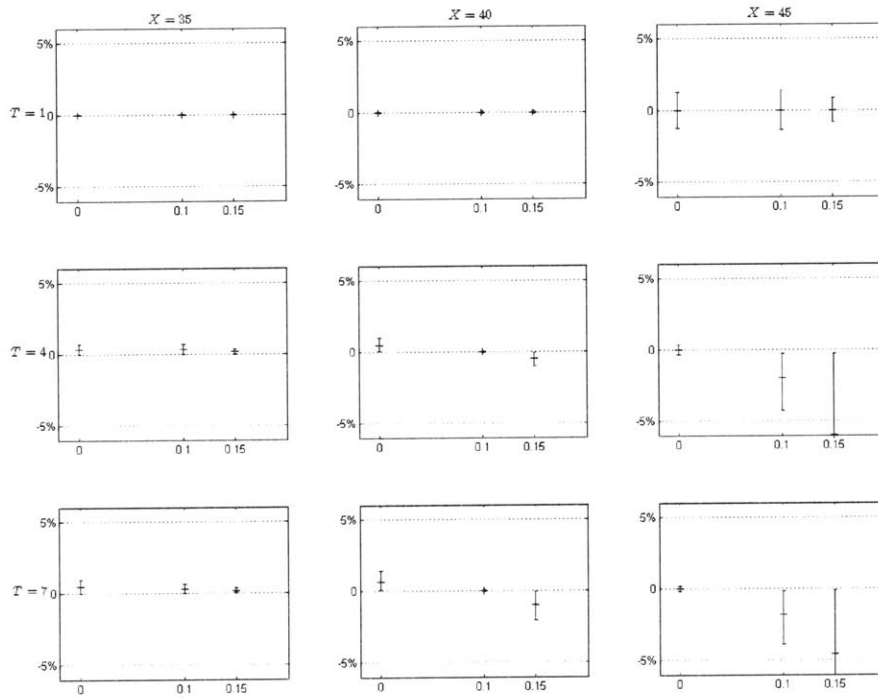

Figure 4-10: American call option: Valuation error compared to continuous-time solution, versus underlying asset risk premium ($\sigma = 0.20$, $X = 35, 40, 45$, $T = 4, 7, 12$ months, $S_0 = 40$, $r_f = 0.05$, $\delta t = T/10$)

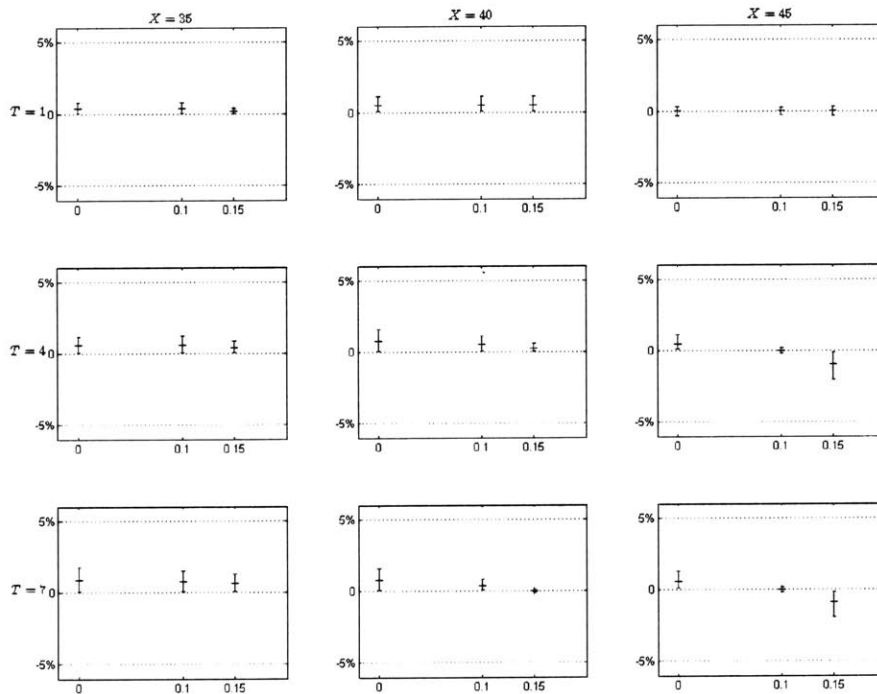

Figure 4-11: American call option: Valuation error compared to continuous-time solution, versus underlying asset risk premium ($\sigma = 0.40$, $X = 35, 40, 45$, $T = 4, 7, 12$ months, $S_0 = 40$, $r_f = 0.05$, $\delta t = T/10$)

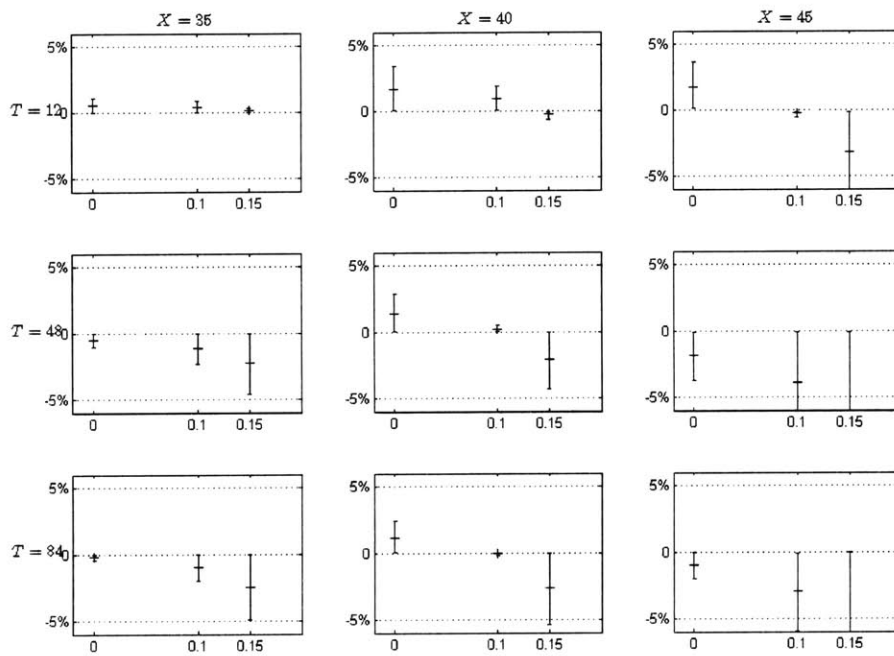

Figure 4-12: American call option: Valuation error compared to continuous-time solution, versus underlying asset risk premium ($\sigma = 0.20$, $X = 35, 40, 45$, $T = 12, 48, 72$ months, $S_0 = 40$, $r_f = 0.05$, $\delta t = T/10$)

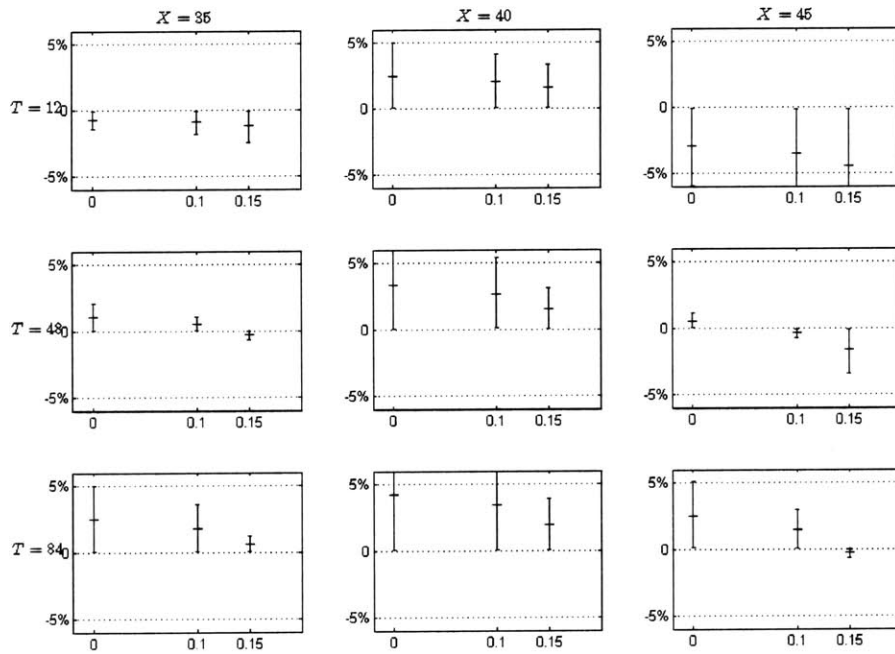

Figure 4-13: American call option: Valuation error compared to continuous-time solution, versus underlying asset risk premium ($\sigma = 0.40$, $X = 35, 40, 45$, $T = 12, 48, 72$ months, $S_0 = 40$, $r_f = 0.05$, $\delta t = T/10$)

largest timing option) will be perfectly correlated with the reference state. In short, if all assets are perfectly correlated then the methodology provides a consistent valuation for all assets and options. The assumption is not absurd: the evolution of many systems involves stages whose values depend on the same underlying uncertainties in exactly the same way. For example, the 3, 4 and 5-level parking garage designs are perfectly correlated in value among them, and also with the uncertain demand. The relative values of these three designs and the options between them can be consistently valued using this methodology.

Moreover, if the reference design is valued correctly from the viewpoint of a diversified investor, i.e., V_{ref} is the market value of the reference design, then the valuation of all other states will also be their market valuation (or the value they would trade at in the market, if they were actually built). In this case, the methodology is both internally consistent and correct from a market valuation perspective.

If the states are not perfectly correlated the result of the valuation will be internally inconsistent and incorrect from a market-value perspective. On one hand, states will be valued only on the basis on the standard deviation of returns, as if they were perfectly correlated with the reference design. From a CAPM perspective, the valuation will ignore all diversification effects between two imperfectly correlated designs, and their impact on those designs' market value (if it exists).

If the assets are uncorrelated, the valuation of options using the proposed methodology will also be inconsistent. If assets u and v are not perfectly correlated, then the payoff of the timing option to transition from u to v will not be perfectly correlated with either state. Therefore, the value of the option should not be either. However, with the proposed methodology the holding value of the option is discounted as if it was perfectly correlated with u , v or V_{ref} . A similar argument explains why the valuation of choice options will also be inconsistent. In short, if the values of states are not perfectly correlated between them, the entire valuation with the proposed methodology will be incorrect from a market-value perspective, and generally, internally inconsistent. However, if the assumption that a market exists for the alternative states is dropped, then it is reasonable to assume that they can be valued solely on the basis of standard deviation of expected returns.

4.5 Summary

The goal for this chapter was to provide a methodology for the calculation of flexibility in programs of standardized developments. The preferred methodology for this was real options, despite the poor penetration it has shown so far with practitioners and engineers. This chapter proposes a novel graphical convention for mapping design and development decisions onto options, and a new valuation methodology for these options. It is hoped that these two contributions have the potential of bringing real options closer to engineering practice, as well as enable consideration of standardization and flexibility in program design.

Chapter 5

FPSO program design study

5.1 Introduction

The purpose of this chapter is to illustrate the application of the two proposed methodologies in a design study for a program of regional FPSO (Floating Production, Storage and Offloading system) developments. The proposed two-step methodology is used for the valuation of a design for a first FPSO, (call it α) as a stage in the development of a program of two units (call the second, β).

An FPSO is a multi-functioning production system that has become an increasingly attractive engineering solution for the development of oilfields remote from export pipeline infrastructure. FPSOs is essentially anchored tankers that receive produced fluids from multiple underwater wells, separate them into oil, gas and water, that is respectively stored, pumped to shore or discarded.

Initially, FPSOs were used for production in smaller or marginal oil fields; today, more than 100 FPSOs of a wide range of production capacities are operating. These vessels' capacities range from relatively low (e.g., Agip's Firenze, with 19 mbd¹ in Italy), up to more than 200mbd (e.g., BP's Greater Plutonio offshore Angola, Figure 5-1). Many features make FPSOs more appealing than other production facilities regardless of production capacity: they are well suited for deep-water developments, which are increasingly exploited as oil resources become scarce, and they are mobile, so they can be retrofitted and reused in multiple fields of shorter production lifecycles (typically around 7-10 years).

Some recent programs of FPSOs and other oil production facilities have been developed according to a new design paradigm, one of complete standardization. For example, Exxon/Mobil's Kizomba A and Kizomba B developments offshore Angola are built almost entirely on the same identical design. BP's development in the Caspian Sea offshore Baku, Azerbaijan, consisted of 6 almost identical fixed platforms. The first three trains at the Atlantic Liquefied Natural Gas (LNG) facilities in Trinidad were designed identically and constructed sequentially. The almost identical design for these facilities was enabled by the

¹mbd stands for thousand barrels (of oil) per day.



Figure 5-1: Greater Plutonio FPSO offshore Angola (operated by BP)

alignment of a number of conditions, related both to market as well as technical requirements. Specifically for the FPSO programs, the justification for many smaller developments instead of fewer larger FPSOs came from diseconomies of scale in FPSO building costs and the changing nature of available fields for exploitation. Consequently, the technical specifications, architectural concept, economic conditions and development time frame were very similar for these smaller projects, allowing significant standardization of systems and components across facilities. Besides the technical environment, the market conditions in which oil producers design, develop and operate facilities have also changed. Specifically, supply of human and physical resources, technical expertise and contractor availability for project delivery, has tightened significantly. These changes are perceived as sources of risk which can be partially mitigated through standardization and design re-use.

However, standardization is no panacea; it introduces a trade-off. Indeed, on one hand, the technical nature of future developments and market conditions advocate fully standardized FPSOs; on the other, some preliminary studies (McGill 2005) have shown that use of a fully standardized design in inappropriate conditions may incur significant cost penalties. The need became apparent for “smart partial standardization,” i.e., for methodology for selecting components and systems that should be standardized.

This chapter illustrates the process presented in this thesis, for smart standardization of FPSO topsides systems between two sequential developments in a program. It is assumed that the decision to standardize certain components between the two systems is taken at the time the *second* asset is designed, and that different standardization strategies (i.e., selection of common components) will be followed optimally based on information available at that time. The value of the first-stage system includes the value of flexibility to optimally design and develop the second development, based on the “design standard” or platform established with the first.

The rest of this section briefly describes the technology and operations of typical FPSO topsides; frames the standardization problem given uncertainty for the future; and describes the approach followed. Section 5.2 describes a model of immediate, observable effects of standardization that is used for the selection of alternative standardization strategies. Section 5.3 applies the IDR methodology for the selection of standardization strategies, and Section 5.4 applies the real options simulation methodology for the valuation of the first-stage design, FPSO α , based on the flexibility it enables to follow one of these strategies. It is shown that the valuation based on the proposed methodology indicates the correct design alternative, despite the fact that it is wrong from a diversified investor's viewpoint.

5.1.1 FPSO process technology description

The incoming fluids from the sub-sea wells are essentially a mix of oil, gas and water. Topsides facilities' main function is to separate the incoming fluids into their components, so that they can be safely exported, stored or discarded. Oil is stored in the hull of an FPSO, and it is periodically offloaded to shuttle tankers. To meet storage and export requirements, oil must be adequately cooled down and stripped off most of the gas that could cause pressure in storage tanks. Gas is re-injected into the reservoir, or exported to shore when technically possible. It cannot be stored in the body of the vessel unless liquefied, a very expensive solution. A small part of the produced gas is also re-used as fuel for the turbine generators of the energy-hungry vessel. Finally, water is deoxygenated before it is pumped back into the reservoir.

A fairly typical process flow diagram (simplified) of these functions is shown in Figure 5-2. Incoming fluids first meet the slug catcher, whose main function is as a buffer that stabilizes the flow of liquids through the rest of the system, and a first-stage gas/oil separator. The oil stream out of the slug catcher is heated prior to entering the high-pressure separation system, where water and solution gas are removed. This is followed by a low pressure separation system, which performs secondary separation necessary to achieve the oil export specifications. The solution gas streams are compressed prior to dehydration and re-injection (or export) to enhance oil recovery. A portion of the produced gas is also used as fuel for the power demands of an FPSO. Finally, gas is used as "lift gas" towards the later field life, in a system that enables better and cheaper recovery from the low-pressure, depleted reservoir. This system recycles gas and mixes it with the incoming fluids at the point of the sub-sea well. In effect, the mix has a lower specific gravity than the original reservoir fluids, and lift to the FPSO is easier.

This design study will focus on the major systems as listed in Table 5.1. Of these systems, the ones represented in Figure 5-2, that also affect the economics and overall design of an FPSO the most are (1) crude oil separation, (2) gas processing, dehydration, compression and possibly export, (3) produced water treatment and handling, (4) seawater treatment and re-injection, and (5) crude oil handling (metering and export). Besides this

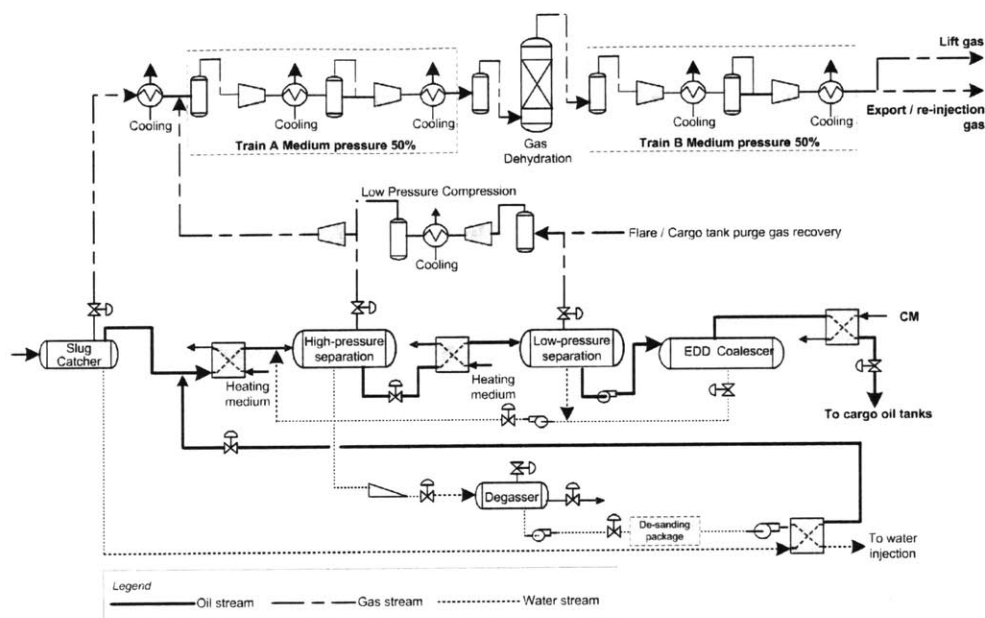

Figure 5-2: Main topsides facilities functions and equipment (simplified)

equipment, FPSO topsides involve numerous support and utility systems that are vital for the operation of oil processing and life safety on board.

The design of FPSO topsides, and particularly of the systems mentioned above, is governed (and co-determines) by a set of exogenous functional requirements and parameters (Table 5.2). Broadly speaking, these are related to the chemical characteristics of the incoming fluids, the technical specifications for the produced oil and gas, and the required processing capacity of the plant. The purpose of a single FPSO design is to maximize value by conforming to these functional requirements, while minimizing initial costs and operating expenses.

5.1.2 FPSO program design case: problem statement and approach

The problem entails the sequential design and construction of two FPSOs. The first, α , is assumed to be in the preliminary design phase (Front-End Engineering Design, FEED), while the design of the second, β , has not yet started. The two FPSOs will be producing oil from adjacent fields at comparable rates. However, their gas processing requirements are expected to be very different. In part, this difference is owed to differences in fluid quality between the two reservoirs. Besides that, FPSO α is planned to start production before onshore gas receiving facilities are available, therefore, initial gas re-injection to the reservoir will have to be utilized. After the onshore gas plant comes online, FPSO α will require only minor conversions before it can export gas. FPSO β is expected to come online after the onshore gas plant is operable and produced gas can be exported. Since gas export

Table 5.1: Main FPSO process systems and utilities

System name	Code
Crude Handling (export)	21
Architectural General - Living Quarters	1
Communication System	86
Instrument Systems	87
Jet Fuel System	61
Gas Compression incl. Cooling and Scrubbing	23
Separation and Stabilization	20
Material Handling	73
Integrated control and safety systems	70
Oily Water Treatment Systems	44
Fire Water and Foam Systems	71
Fuel Gas System	45
High Pressure Sea Water System	51
Fresh Water Systems	53
Diesel System	62
Chemical Injection Systems	42
Inert Purge System	64
Flare, Vent and Blowdown Systems	43
Seawater Systems (Low to Medium Pressure)	50
Heating Systems	41
Battery System and Uninterruptible Power Supply	85
Open Drain System	56
Compressed Air Systems	63
Main Power Generation and Distribution 13.3kV	80
Halon/CO2 Systems	72

requires much lower compression ratios than re-injection, and because of the two reservoirs have different compositions, the functional requirements for the second development are assumed to be somewhat different than for α regarding gas handling capacity (Figure 5-3 and Table 5.2).

From Figure 4, standardization appears to be a viable strategy between FPSOs α and β ; all key specifications and functional requirements except three are identical at the conceptual level of definition. The developer's alternative standardization strategies are broadly the following:

1. Design and build both FPSOs as independent assets, with no consideration for standardized systems and components among them.
2. Develop a single FPSO design that satisfies the most onerous requirements of both FPSOs α and β . This corresponds to the "full-standardization" approach, which probably exploits standardization benefits the most, but also implies that one of the two units is greatly over-designed.

Table 5.2: Assumed functional requirements for FPSO α and β

Functional requirement	FPSO α	FPSO β_0	Units
Inlet Oil Rate	275	275	mbd
Gas Lift Rate	120	45	mmscfd
Inlet Gas Rate	200	75	mmscfd
Gas Injection Rate	180	68	mmscfd
Number Of Risers	4	4	-
Export Oil Rate	100	100	mbod
Crude Quality	24	24	°API
Gas Injection Pressure	350	350	bara
Inlet Fluids Pressure	35	35	bara
Inlet Fluids Temperature	50	50	°C
Produced Water Rate	220	220	mbd
Water Injection Rate	259	259	mbd
Water Injection Pressure	225	225	bara

3. Design FPSO β so that it shares some of its components' designs with FPSO α . This strategy can be planned as a fixed commitment from the time α is designed, or in a flexible manner.
 - (a) A fixed-commitment strategy involves that choosing an appropriate set of components and systems on FPSO α and committing to their re-use on FPSO β .
 - (b) A flexible strategy involves choosing an appropriate set of components and systems on FPSO α , but without committing to their re-use on FPSO β . The developer retains the flexibility to utilize as much of the existing FPSO α design as the economic and technical conditions deem appropriate at the time FPSO β is designed. This decision will also allow consideration of design, procurement, construction and initial operation lessons learned.

Strategy 1 involves no standardization; it is the development paradigm followed in the oil production industry until recently. It practically ensures that both FPSOs will be optimized around the resources and economic conditions at the time of their development, because each FPSO is optimized with no regard for future developments. Strategy 2 represents a significant design paradigm shift, recently manifested in the oil industry with the development of series of identical facilities. It taps into benefits of standardization, such as design re-use, learning curve effects, preferred contractor agreements etc.; on the other hand, it may imply severe standardization cost penalties compared to individually optimized FPSOs designed per strategy 1. Strategy 3 represents the current trend towards *smart standardization*, where the economic benefits from re-using existing, standardized designs in FPSO β are traded-off against the benefits from fully customizing it.

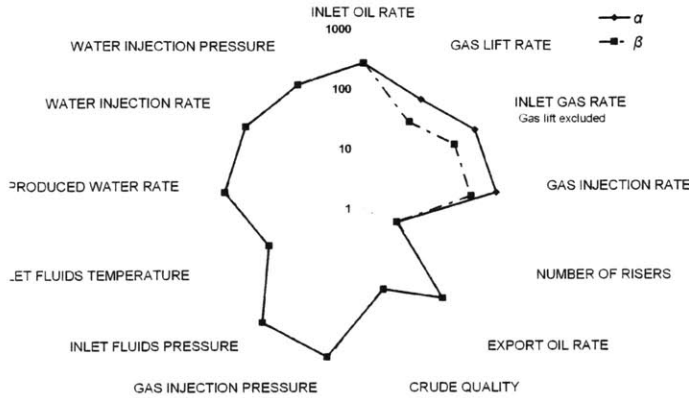

Figure 5-3: Comparison between assumed functional requirements of FPSOs α and β

Approaches 3a and 3b are different ways of *valuing* smart standardization strategies, and specifically FPSO α . Approach 3a represents a “discounted-cash-flow” line of thinking, with commitment at an early date to decisions that can be postponed until later. Although actually doing so can be beneficial,² it is a mistake to value the program *as if* it were fully inflexible, if in reality it is not. Approach 3b is the proposed valuation paradigm, whereby future decisions are modeled to be contingent on future events, and current decisions are made based (partly) on the flexibility they create for the future.

What is the difference between strategies 1 and 3b? Both approaches suggest that design decisions for FPSO β are made at the time FPSO β is designed, not before. The difference is subtle, and concerns the optimality criterion on which the design of FPSO α is based. Strategy 1 suggests the optimization of FPSO α as if it were the only development, and does not account the possible standardization opportunities enabled for the design of β . Approach 3b does, capturing the real opportunities created by standardization. In other words, the value difference between an individually optimized FPSO α according to strategy 1 and an FPSO α optimized according to strategy 3b is the *total value of standardization*, including the value of flexibility:

$$\left[\begin{array}{l} \text{Total value created} \\ \text{by standardization} \end{array} \right] = \left[\begin{array}{l} \text{Value of design } \alpha \text{ that was} \\ \text{optimized with approach} \\ \text{3b, as calculated with} \\ \text{approach 1} \end{array} \right] - \left[\begin{array}{l} \text{Value of design } \alpha \\ \text{that was optimized} \\ \text{and calculated with} \\ \text{approach 1} \end{array} \right]$$

What is then the value of flexibility? The answer is, the difference between the valuation

² Committing *a-priori* to design decisions that can be normally postponed can be a good strategy, e.g., because some of the value of standardization can be transferred to the developer only if its suppliers receive prior commitment to future orders. This effect is not considered in this work, although the proposed methodology is perfectly capable of modeling it; see 6.

of an FPSO α according to approach 3b, minus its value according to approach 3a. This difference is obviously due just to the fact that approach 3a ignores the future flexibility created for the development of FPSO β and assumes that all decisions for both units are taken *a-priori*. If there is any reason not to commit to these decisions beforehand, e.g., if there is any uncertainty, then delaying the decisions for FPSO β has value. This additional value is captured in valuation approach 3b, but not in approach 3a.

Another way of saying the above is that the design of FPSO α creates a platform on which the developer can base the design of β , if it is optimal to do so in the future. The design decisions for FPSO α only make it more or less likely that the established platform will be optimally adhered to when FPSO β is developed, and the extent to which this might happen. Therefore, the expected value of FPSO α , which is the objective of its design, should also include the flexibility it creates for the organization to choose how to design and develop FPSO β . This includes:

- The flexibility to utilize the existing design of FPSO α for FPSO β at varying degrees, i.e., re-use the design of different combinations of systems, components, and supply chain agreements.
- The flexibility to choose the timing of development of FPSO β , and the right to wait before finalizing the design or starting the development of FPSO β .

These decisions on alternative designs and development timing can be modeled using the graphical modeling convention introduced in Chapter 4, as shown in Figure 5-4. Initially, the developer operates FPSO α . This state has intrinsic value due to the operating cash flows it generates. It also has value because it gives the developer the option to design any of the alternative FPSOs $\beta_1 \dots \beta_n$, each of which corresponds to a different selection of standardized components. The developer may postpone this design decision indefinitely, i.e., never exercise the choice option at the *OR* node. Alternatively, the developer may decide among $\beta_1 \dots \beta_n$, incurring design costs. In this model, it is assumed that once made, a design decision cannot be reversed.³ After a certain time lag that corresponds to Front-End-Engineering-Design (FEED), denoted as $TtD_1 \dots TtD_n$ for each alternative FPSO β , the developer obtains the right to begin construction of the chosen design. After the “construction go-ahead,” which can also be delayed, the developer obtains the chosen FPSO β_i and operates both α and β_i simultaneously.

One challenge with valuing the flexibility inherent in FPSO α is the number of alternative standardization strategies $\beta_1 \dots \beta_n$. The IDR methodology (chapter 3) is used to screen standardization strategies for FPSO β and reduce n .

The screening of alternative standardization strategies is based on the effects on the development of FPSO β that can be measured with relative certainty from the time FPSO

³Given the long design time for such vessels, which is in the order of years, this is not a very restrictive assumption: there is good incentive to finalize design before commencing it.

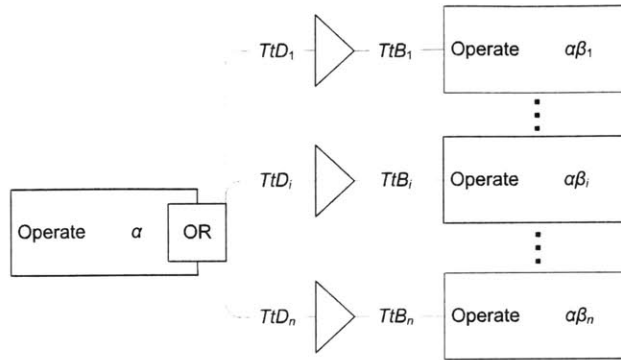

Figure 5-4: FPSOs α and β program development decisions

α is designed. Some of these effects involve estimates of operating cost reduction for as long as both FPSOs operate simultaneously; reduction of design and construction cost for FPSO β ; reduction of the design and construction time lag, which expedites cash flows generated from the second FPSO, increasing their value. A detailed model of the effects of alternative standardization strategies in the design and construction of FPSO β is presented in Section 5.2.

Screening alternative standardization strategies so as to maximize the reduction in spare part inventories, FEED cost and time, and construction cost and time, will produce potentially optimal designs for FPSO β . This is because:

- the value of a standardized second FPSO increases monotonically as the standardization effects increase, all else being equal. For example, a shorter design time is always more valuable than a longer one. Therefore, all the standardization effects are to be maximized.
- there is a trade-off between these standardization effects: due to technical constraints, it is impossible to increase all standardization effects simultaneously.

Therefore, the problem is to select the designs $\beta_1 \dots \beta_n$ that lie on the Pareto front of standardized designs that maximize the effects described previously. This is done using the IDR methodology presented in Chapter 3, and presented in Section 5.3.

The final part of the methodology (Section 5.4) uses the flexibility valuation algorithm to assess the value of FPSO α that enables the design of alternatives $\beta_1 \dots \beta_n$. In a world without uncertainty, it would be possible to determine from the start which of the designs $\beta_1 \dots \beta_n$ would be optimal as the second development, and consequently the value of α . This logic was captured in strategy 3a (see p.110). In the presence of uncertainties, any of the previously identified designs $\beta_1 \dots \beta_n$ may be optimal to develop in different states of the world. The uncertainties s_i for this design study are assumed to be the price of oil

(s_t^{oil}), gas (s_t^{gas}) and steel (s_t^{stl}):

$$\mathbf{s}_t = \{s_t^{oil}, s_t^{gas}, s_t^{stl}\}$$

For example, in a state of the world of high oil or gas prices and low steel prices, a standardization solution that uses heavier equipment and more steel, but expedites the development program significantly might be pursued; if the reverse conditions prevail, a solution which is slower to develop but very economic in steel may be optimal. For illustration purposes, it is assumed that the uncertainties are the price of oil, the price of gas and the price of steel (which in part determines the construction cost).

5.2 Standardization effects

The effects oil producing companies have so far experienced from standardization have yielded hundreds of millions of dollars in value created. The Kizomba A and Kizomba B developments offshore Angola are a recent example of a multi-project program delivered by a “design one, build many” approach, saving some 10-15% in capital expenses (circa \$400M) and 6 months in cycle time. Generally, duplication of facility designs has been found to create value for the second and subsequent developments in three major ways (Figure 5-5): first, capital expense (CAPEX) reduction, mainly due to repeat engineering, contracts with preferred suppliers, discounts for material and services and integration efficiency. Secondly, value is created due to reduced operating expenses (OPEX) for the second and subsequent projects. This is mainly due to reduced risk in start-up efficiency, improved uptime, and commonality of spares and training. Finally, project engineers and managers use proven designs and commissioned interfaces without “re-inventing the wheel.” Standardization implies reduced FEED effort requirements, fewer mistakes, increased productivity, learning etc., which in turn imply reduced cycle time. This can be extremely valuable by accelerating the receipt of cash flows from operations, thus increasing their value. Given a growing concern in the oil industry about the availability of skilled human resources cycle-time minimization becomes an even greater source of value.

Preliminary data for these effects can be found in focused studies commissioned to engineering contractors, e.g., Hyundai Heavy Industries Co. Ltd (2005) and Daewoo Shipbuilding & Marine Engineering Co. Ltd. (2005), or findings from oil producers’ (limited) experience with standardization; e.g., McGill & de Neufville (2005). Not surprisingly, the former studies indicate much lower expected standardization benefits than the latter ones: a contractor publishing significant learning curve effects effectively implies that significant and costly mistakes are made in the development of the first projects in a program. Moreover, contractors have clear disincentive to claim significant reductions in design and construction costs, because in an inefficient market they can claim the value created instead of passing it to the owners. As a result, even though data on standardization effects exists, it should be used with scrutiny. For illustration purposes, existing data on design and construction

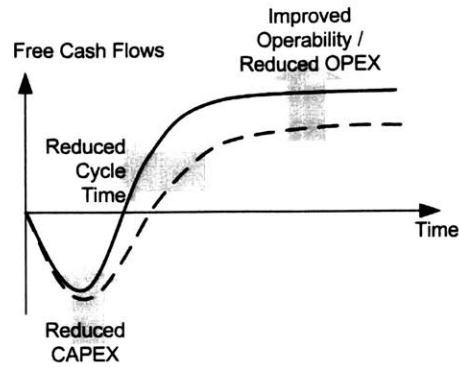

Figure 5-5: Effects of system standardization between FPSOs α and β

effects from duplicating entire FPSOs is used in this design study, with the recognition that an accurate account of these benefits is a matter of further research.

The data on the effects of standardization in oil production projects so far applies to fully standardized projects that are based on duplicate designs (strategy 2 in page 109). In order to assess partial standardization strategies (according to strategy 3 in Section 5.1.2), a model is needed that helps the assessment of standardization effects given the systems and components whose design is re-used. These effects do not only depend directly on standardization extent (e.g., by number of systems or by weight), because each of the main FPSO systems has different requirements in design man-hours, equipment or bulk material costs and labor costs (Figure 5-6); they depend on which elements from the design of FPSO α are re-used. The purpose of this section is to provide such a model. The next paragraphs quantify partial standardization effects in the form of normalized functions. For example, the function for reduction of capital expenses for construction of the entire FPSO β would take the form

$$\text{CAPEX reduction for } \beta = \frac{\text{CAPEX for } \beta \text{ given partial standardization with } \alpha}{\text{CAPEX } \beta \text{ without any standardization}}$$

where the nominator represents a design where the customized components are optimized for FPSO β and the standardized ones are identical to FPSO α . The denominator represents a design where all components are customized for FPSO β . This design, i.e., a fully customized design for the second FPSO, is denoted from now on as FPSO β_0 .

5.2.1 Reduction in operating expenses

Evidence indicates that the simultaneous operation of two (or more) FPSOs that share standardized systems and components is cheaper than what it would be if the systems shared no commonality. This is due to reduced maintenance expenses, reduced spare part inventories, smaller need for training specialized personnel etc. The reduction in operating expenses due

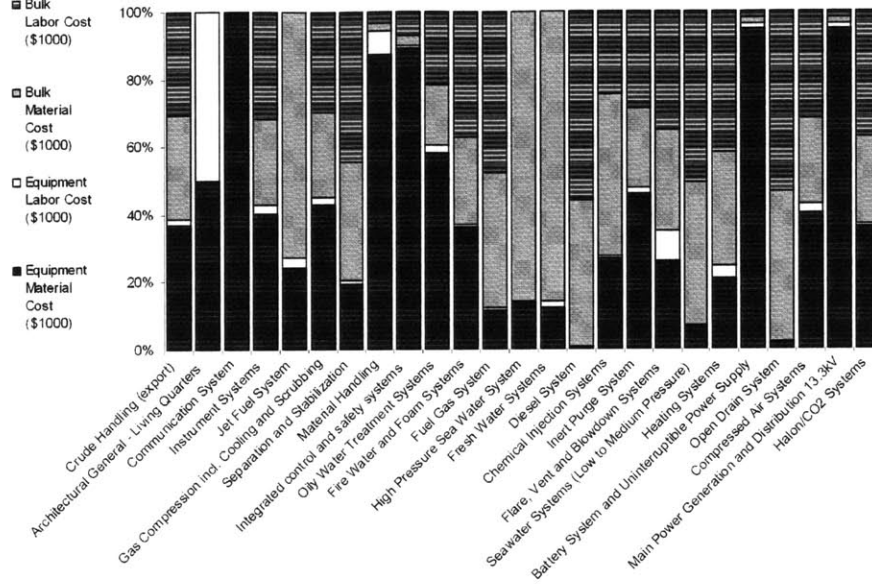

Figure 5-6: Assumed percent breakdown of development costs by system, FPSO α

to standardization implies an increase in operating free cash flows (i.e., operating revenue - costs). The free cash flow generated from FPSO α individually can be written as

$$CF(\mathbf{x}^\alpha, \mathbf{s}_t) = CAP_\alpha^{oil} s_t^{oil} + CAP_\alpha^{gas} s_t^{gas} - CF^{var}(\mathbf{x}^\alpha, \mathbf{s}_t) - CF^{fix}(\mathbf{x}^\alpha, \mathbf{s}_t)$$

where CAP_α^{oil} , CAP_α^{gas} are the oil and gas production capacity of each FPSO respectively, s_t^{oil} , s_t^{gas} are the spot prices for oil and gas respectively, and $CF_\alpha^{var} \equiv CF^{var}(\mathbf{x}^\alpha, \mathbf{s}_t)$ are the variable operating costs, which correspond mainly to energy required for production. These can be approximated as a fraction of $P_\alpha^{gas} s_t^{gas}$ because power is generated from production gas in FPSOs such as the ones examined.

Finally, $CF_\alpha^{fix} \equiv CF^{fix}(\mathbf{x}^\alpha, \mathbf{s}_t)$ denotes fixed costs, which correspond to labor, maintenance and spare parts, and are the main source of benefit from standardization as far as operating costs are concerned. Annual fixed costs are calculated as approximately 2% of Equipment and Bulk Material Costs for each system. The fixed operating expenses for the simultaneous operation of the same system on both FPSOs are assumed to be only half of their nominal value, because of shared maintenance and inventory costs (see Section 2.3).⁴ With these assumptions, it is possible to calculate the function $g_1(\mathbf{x}^\alpha, \mathbf{x}^\beta)$, i.e., the percent

⁴This number is just assumed for illustrative purposes; in a real design study it would have to be estimated using a maintenance model. For more information and models for spare part inventory and maintenance costs in petroleum production see the references for Section 2.3.

reduction in maintenance and spare part inventory costs for partially standardized FPSOs:

$$g_1(\mathbf{x}^\alpha, \mathbf{x}^\beta) = \left(1 - \frac{CF_{\alpha\beta}^{fix}}{CF_\alpha^{fix} + CF_\beta^{fix}} \right) 100\% \quad (5.1)$$

For example, consider the designs α and β_0 , each optimized individually around the specifications given in Table 5.2 and Figure 5-3. Table 5.3 shows the annual maintenance costs for each piece of equipment on each design. Consider now a design for FPSO β , in which only the gas compression system (system 23) is common with FPSO α . Then the annual maintenance cost for this system for both FPSOs will be only \$219,810. If both FPSOs use the system designed for FPSO β_0 then the annual maintenance cost would be only \$120,400 (but the gas processing capacity of FPSO α would be severely compromised); if the two FPSOs used different systems then the annual maintenance costs would rise to \$120,400 + 219,810 = \$340,210. These differences in fixed maintenance costs can be used for the calculation of $g_1(\mathbf{x}^\alpha, \mathbf{x}^\beta)$ for each standardization solution.

Table 5.3: Assumed FPSO annual spare part costs for each system (\$1,000)

System name	FPSO α	FPSO β_0
	2% of equipm. bulk	2% of equipm. bulk
Crude Handling (export)	50.73	50.73
Architectural General - Living Quarters	5.78	5.78
Communication System	5.00	5.00
Instrument Systems	11.01	10.68
Jet Fuel System	7.45	6.85
Gas Compression incl. Cooling and Scrubbing	219.81	120.30
Separation and Stabilization	869.61	787.94
Material Handling	27.23	26.51
Integrated control and safety systems	38.81	38.81
Oily Water Treatment Systems	562.74	562.75
Fire Water and Foam Systems	151.60	133.08
Fuel Gas System	9.03	8.31
High Pressure Sea Water System	95.74	17.80
Fresh Water Systems	10.45	10.45
Diesel System	7.11	6.76
Chemical Injection Systems	11.24	10.78
Inert Purge System	9.96	9.73
Flare, Vent and Blowdown Systems	21.86	16.49
Seawater Systems (Low to Medium Pressure)	109.01	23.90
Heating Systems	195.14	184.67
Battery System and Uninterruptible Power Supply	5.54	5.45
Open Drain System	67.68	59.16
Compressed Air Systems	11.01	10.68
Main Power Generation and Distribution 13.3kV	1,661.38	1,651.24
Halon/CO2 Systems	46.29	48.47

The function $g_1(\mathbf{x}^\alpha, \mathbf{x}^\beta)$ does not correspond directly to value created from standardization, it is only a factor of decrease in fixed operating expenses. The actual free cash flows generated by each FPSO are a function of the prices of oil and gas, the variable costs etc. However, it is certain that larger values of $g_1(\mathbf{x}^\alpha, \mathbf{x}^\beta)$ correspond to larger value for the entire program, all else being equal. Therefore, the organization seeks to maximize $g_1(\mathbf{x}^\alpha, \mathbf{x}^\beta)$ through the design of α and β .

5.2.2 Reduction in FEED cost and time

Front-end engineering design (FEED) is perhaps the phase of the development process most affected by a platform strategy and standardization of systems. The reasons are self-evident: FEED, involving tasks such as chemical process modeling, equipment sizing, production schedule planning, hull design and integration planning, is mostly insensitive to the small changes required in (nominally) almost identical systems. So a largely standardized system saves the effort of preliminary design for every variant. Like in the previous section, the impact of partial FPSO standardization on preliminary (FEED) engineering cost is modeled using a factor g_2 as follows:

$$D_{\alpha\beta} = D_{\beta_0}[1 - g_2(\mathbf{x}^\alpha, \mathbf{x}^\beta)] \quad (5.2)$$

where $D_{\alpha\beta}(\mathbf{s}_t)$ is the FEED cost of designing an FPSO β partially standardized with FPSO α , and D_{β_0} is the FEED cost of designing a fully customized FPSO β_0 anew.

The impact on design time can be modeled similarly:

$$TtD_{\alpha\beta}(\mathbf{s}_t) = TtD_{\beta_0}(\mathbf{s}_t)[1 - g_3(\mathbf{x}^\alpha, \mathbf{x}^\beta)] \quad (5.3)$$

where $TtD_{\alpha\beta}(\mathbf{s}_t)$ is the time required for the front-end design of FPSO β , given that FPSO α is already designed, and TtD_{β_0} is the cost and time required for the design of the individually-designed, optimized FPSO β_0 .

Reduction in FEED cost It is customary in the design of oil exploration and production facilities to calculate direct design time and cost for a system in proportion to its weight (equipment and bulk). On this basis, the design cost for each system on FPSOs α and β_0 is calculated according to Berwanger (2004) as shown in Table 5.4. The FEED costs for implementing entirely the same design on a second FPSO (100% standardization) are estimated to be around 25% of the initial FEED costs. This remaining cost is attributed to design integration, checking etc. If the second development is partially standardized, the reduction is calculated by reducing the FEED costs by 75% for each standardized system. So g_2 can be written as follows:

$$g_2(\mathbf{x}^\alpha, \mathbf{x}^\beta) = 1 - \frac{D_{\alpha\beta}}{D_{\beta_0}} = \left(1 - \frac{D_{\beta_0} - \Delta D(\mathbf{x}^\alpha, \mathbf{x}^\beta)}{D_{\beta_0}}\right) 100\%$$

where $\Delta D(\mathbf{x}^\alpha, \mathbf{x}^\beta)$ is the design cost of the standardized components if they are optimized for FPSO β_0 , minus 25% of the design cost of the respective components, if they are optimized for FPSO α .

For example, if FPSO α 's gas compression design (system 23 in Table 5.1, p.109) is used without any alterations on FPSO β , then the FEED cost for that system is calculated as $(0.25)(1,335) = \$334,000$. The design cost difference between the partially standardized FPSO β and the individually optimized FPSO β_0 is $\Delta D(\mathbf{x}^\alpha, \mathbf{x}^\beta) = 451 - 334 = 117$ (from Table 5.4). Therefore, between two designs on that share only the design of system 23 (if this were possible⁵) the function $g_2(\mathbf{x}^\alpha, \mathbf{x}^\beta)$ that expresses standardization benefits in terms of FEED cost is calculated as

$$g_2(\mathbf{x}^\alpha, \mathbf{x}^\beta) = 1 - \frac{D_{\alpha\beta}}{D_{\beta_0}} = 1 - \frac{D_{\beta_0} - \Delta D(\mathbf{x}^\alpha, \mathbf{x}^\beta)}{D_{\beta_0}} = 1 - \frac{18,011 - 117}{18,011} \approx 0.7\%$$

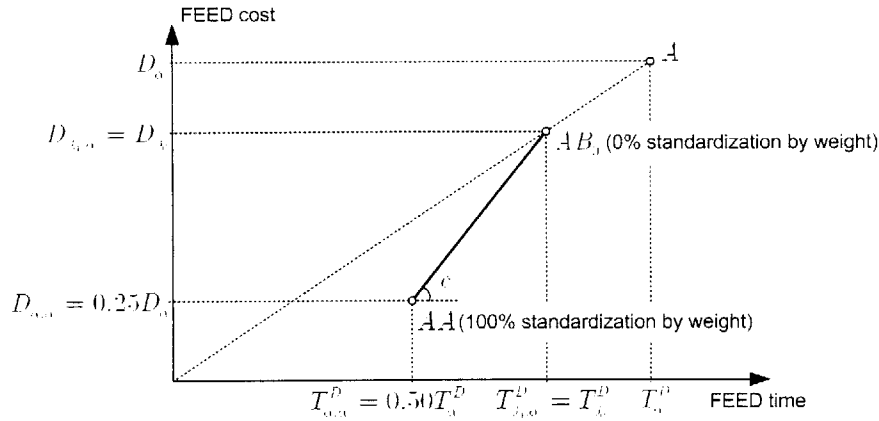

Figure 5-7: FEED cost and time as a function of standardization by weight

Reduction in FEED time The reduction in FEED design time is modeled to be proportional to the reduction in FEED cost. Figure 5-7 shows how the relationship between the two is found. Duplicating the design of FPSO α (i.e., fully standardizing FPSO β , point AA in Figure 5-7) costs $0.25D_\alpha = (0.25)(\$20m) = \$5m$ in FEED costs and requires $0.50TtD_\alpha = (0.50)(365) = 183$ days in FEED time. The factors 0.25 and 0.50 represent essentially cost and time experience curves in design. According to preliminary engineering data from Hyundai Heavy Industries Co. Ltd (2005) and Daewoo Shipbuilding & Marine Engineering Co. Ltd. (2005), the FEED design of a completely new, custom-optimized FPSO β_0 costs $D_{\beta_0} = \$18.011m$ and requires $TtD_{\beta_0} = 328$ days (point AB0 in Figure 5-7).

⁵Standardizing only this system will rarely be possible because of the couplings between systems on the FPSO. So the calculation of $g_2(\mathbf{x}^\alpha, \mathbf{x}^\beta)$ shown here is essentially the marginal contribution of standardizing system 23 when no other system is standardized.

This implies that the opportunity FEED cost per day for standardization is constant, and equal to

$$c = \frac{D_{\beta_0} - 0.25D_{\alpha}}{TtD_{\beta_0} - 0.50TtD_{\alpha}} = \frac{18.011 - 5.000}{328 - 183} \approx \$90,000/\text{day}$$

Table 5.4: Assumed FPSO FEED costs for each system (\$1,000)

System name	FPSO α	FPSO β_0
Crude Handling (export)	136.4	136.4
Architectural General - Living Quarters	1190.0	1190.0
Communication System	3.6	3.6
Instrument Systems	40.5	40.5
Jet Fuel System	95.2	95.2
Gas Compression incl. Cooling and Scrubbing	1335.9	451.7
Separation and Stabilization	6173.7	5579.9
Material Handling	288.5	287.0
Integrated control and safety systems	42.8	42.8
Oily Water Treatment Systems	1669.6	1669.6
Fire Water and Foam Systems	178.0	175.4
Fuel Gas System	91.2	90.7
High Pressure Sea Water System	0.0	0.0
Fresh Water Systems	0.0	0.0
Diesel System	1.4	1.4
Chemical Injection Systems	14.3	14.3
Inert Purge System	24.3	24.3
Flare, Vent and Blowdown Systems	591.0	446.5
Seawater Systems (Low to Medium Pressure)	0.0	0.0
Heating Systems	2365.0	2172.2
Battery System and Uninterruptible Power Supply	26.8	26.4
Open Drain System	27.4	27.4
Compressed Air Systems	40.5	40.5
Main Power Generation and Distribution 13.3kV	5644.8	5604.2
Halon/CO2 Systems	19.3	19.0

Based on Figure 5-7, the required FEED time for a partially standardized FPSO β can then be calculated as

$$TtD_{\alpha\beta} = TtD_{\beta_0} - c^{-1}\Delta D(\mathbf{x}^{\alpha}, \mathbf{x}^{\beta})$$

To see this, notice that if the difference in design cost $\Delta D(\mathbf{x}^{\alpha}, \mathbf{x}^{\beta})$ is zero, then $TtD_{\beta} = TtD_{\beta_0}$: FPSO β is identical to β_0 ; if $\Delta D = TtD_{\beta_0} - 0.50TtD_{\alpha}$ then FPSO β is identical to FPSO α , exploiting fully the reduction in FEED time due to standardization. The function

$g_3(\mathbf{x}^\alpha, \mathbf{x}^\beta)$ can be written as

$$\begin{aligned}
& TtD_{\alpha\beta} = TtD_{\beta_0}[1 - g_3(\mathbf{x}^\alpha, \mathbf{x}^\beta)] \\
\Rightarrow & g_3(\mathbf{x}^\alpha, \mathbf{x}^\beta) = 1 - TtD_{\alpha\beta}/TtD_{\beta_0} \\
\Rightarrow & g_3(\mathbf{x}^\alpha, \mathbf{x}^\beta) = 1 - \frac{TtD_{\beta_0} - c^{-1}\Delta D(\mathbf{x}^\alpha, \mathbf{x}^\beta)}{TtD_{\beta_0}} \quad (5.4) \\
\Rightarrow & g_3(\mathbf{x}^\alpha, \mathbf{x}^\beta) = \left(\frac{\Delta D(\mathbf{x}^\alpha, \mathbf{x}^\beta)}{cTtD_{\beta_0}} \right) 100\%
\end{aligned}$$

5.2.3 Reduction in construction cost

Construction costs include labor cost of equipment and bulk as well as an overhead (e.g., project management, detailed engineering, construction supervision, procurement services, inspection etc.). Hyundai Heavy Industries Co. Ltd (2005) and Daewoo Shipbuilding & Marine Engineering Co. Ltd. (2005) provide estimations for these learning curve effects for a series of identical FPSO topsides manufactured in a row as shown in Figure 5-8. The total construction cost reduction for duplicating an existing FPSO (by the same contractor within a reasonable amount of time from the first development) is potentially 2% for material and bulk, and 10% on average for labor (engineering, fabrication etc.). As discussed above, this data is expected to predict smaller effects than the industry averages (e.g., as reported by NASA in Table 2.1, p. 31).

Construction cost is assumed not to be deterministically known, but also significantly affected by uncertain factors, such as the price of steel. This dependency is captured here by writing $C_{\alpha\beta}(\mathbf{s}_t)$ to denote the construction cost of a partially standardized FPSO β given the existence of FPSO α already, and $C_{\beta_0}(\mathbf{s}_t)$ the construction cost of an individually optimized FPSO β_0 . Then the construction cost reduction for the second FPSO due to partial standardization with the first is denoted g_4 (percent), and written as

$$C_{\alpha\beta}(\mathbf{s}_t) = C_{\beta_0}(\mathbf{s}_t)[1 - g_4(\mathbf{x}^\alpha, \mathbf{x}^\beta)] \quad (5.5)$$

For the purpose of this design study, the impact of steel price on the construction cost was taken to be linear, affecting the “Equipment Material” and “Bulk Material” cost items only.

To estimate the function $g_4(\mathbf{x}^\alpha, \mathbf{x}^\beta)$ cost savings or increases can be apportioned to individual standardized systems assuming these learning curve effects apply to each system separately. For example, the construction cost of system 23, *Gas Compression, Cooling and Scrubbing*, can be estimated for FPSO α as $(2,788.8 + 1,607.3) + (155.1 + 1,953.4) = 6,504$ (Table 5.5). If the same design is used in FPSO β , the cost for system 23 in β can be \$298,000 cheaper, calculated as $6,504 - (2,788.8 + 1,607.3)(0.98) + (155.1 + 1,953.4)(0.90) = 298$. If this system had been customized for FPSO β (as assumed in the design β_0) then its total cost would be $(1,744.1 + 73.3) + (663.2 + 806.0) = 3,285$ (from Table 5.6). Denoting the difference $\Delta C(\mathbf{x}^\alpha, \mathbf{x}^\beta) = 3,285 - 6,206 = -2,921$ shows that re-using the design of system 23 from FPSO α on FPSO β incurs a “standardization penalty,” because of over-sizing the equipment above its required capacity. This penalty is larger than the learning curve effects

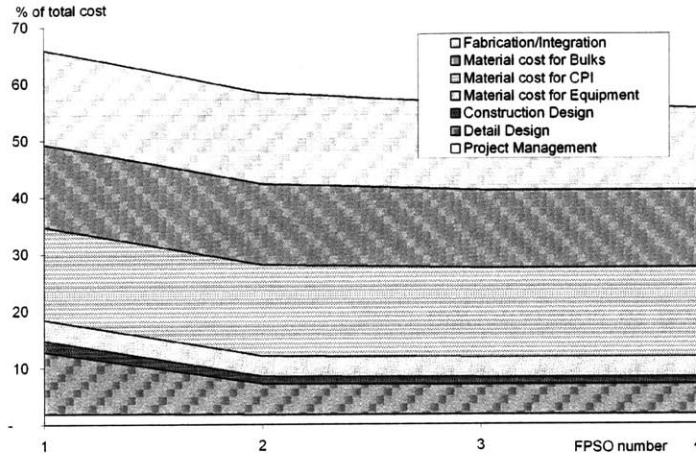

Figure 5-8: Assumed learning curves in FPSO construction costs

that make the second instance of system 23 cheaper than the first by \$298,000. If only this system were standardized between FPSOs α and β , the corresponding g_4 function would read

$$\begin{aligned}
 g_4(\mathbf{x}^\alpha, \mathbf{x}^\beta) &= 1 - \frac{C_{\alpha\beta}(s_t)}{C_{\beta_0}(s_t)} \\
 &= 1 - \frac{C_{\beta_0}(s_t) - \Delta C(\mathbf{x}^\alpha, \mathbf{x}^\beta)}{C_{\beta_0}(s_t)} \\
 &= 1 - \frac{103,039 - 3,285 + 6,206}{103,039} = -2.8\%
 \end{aligned}$$

i.e., around a 3% cost increase.

5.2.4 Reduction in construction time

A typical schedule of construction activities for an FPSO includes 3 major phases: pre-fabrication design (i.e., detailed and construction design), system fabrication and system installation and integration. For the last phase, installation and integration, the schedule reduction is assumed in this analysis to be negligible.⁶ For the other two phases, the reduction in construction schedule for a fully standardized second FPSO is extracted from existing assumed data and allocated to individual systems.

Reduction in detailed and construction design time is nominally around 50% for a fully-standardized second development, and is apportioned to individual systems depending on their contribution to the total construction cost. Considering that detailed/construction design costs account for approximately 14.5% of the total construction costs; total construction cost is \$103.039m for FPSO β_0 and \$114.344m for FPSO α ; and FPSO β_0 requires

⁶One justification for this is that integration benefits are realized only if there are no customized components.

Table 5.5: Assumed FPSO α construction costs for each system (\$1,000)

System name	Equipment	Equipment	Bulk	Bulk
	Material cost (\$1,000)	Labor cost (\$1,000)	Material cost (\$1,000)	Labor cost (\$1,000)
Crude Handling (export)	554.98	24.14	459.55	458.81
Architectural General - Living Quarters	50.00	50.00	0.00	0.00
Communication System	100.00	0.00	0.00	0.00
Instrument Systems	134.76	7.65	85.43	105.32
Jet Fuel System	40.00	5.00	120.00	0.00
Gas Compression incl. Cooling and Scrubbing	2788.83	155.06	1607.33	1953.36
Separation and Stabilization	6164.66	351.08	11227.56	14127.68
Material Handling	530.91	42.98	13.60	19.37
Integrated control and safety systems	752.00	7.20	24.25	60.12
Oily Water Treatment Systems	8606.91	315.67	2647.99	3200.94
Fire Water and Foam Systems	1774.36	36.28	1257.54	1821.77
Fuel Gas System	40.64	2.46	140.05	167.14
High Pressure Sea Water System	300.67	12.74	1879.58	0.00
Fresh Water Systems	200.00	25.00	1378.00	0.00
Diesel System	2.22	0.29	139.90	181.66
Chemical Injection Systems	81.14	2.72	143.73	74.46
Inert Purge System	131.15	4.59	68.09	81.49
Flare, Vent and Blowdown Systems	205.44	70.67	231.79	276.64
Seawater Systems (Low to Medium Pressure)	300.67	12.74	1879.58	2245.71
Heating Systems	1506.95	259.55	2395.76	3004.25
Battery System and Uninterruptible Power Supply	108.67	1.97	2.05	2.03
Open Drain System	57.06	5.18	1296.49	1547.01
Compressed Air Systems	134.76	7.65	85.43	105.32
Main Power Generation and Distribution 13.3kV	32612.09	590.44	615.49	610.11
Halon/CO2 Systems	541.80	11.08	383.99	556.28

Table 5.6: Assumed FPSO β construction costs for each system (\$1,000)

System name	Equipment	Equipment	Bulk	Bulk
	Material cost (\$1,000)	Labor cost (\$1,000)	Material cost (\$1,000)	Labor cost (\$1,000)
Crude Handling (export)	554.98	24.14	459.55	458.81
Architectural General - Living Quarters	50.00	50.00	0.00	0.00
Communication System	100.00	0.00	0.00	0.00
Instrument Systems	135.23	7.65	78.35	96.40
Jet Fuel System	40.00	5.00	120.00	0.00
Gas Compression incl. Cooling and Scrubbing	1744.12	73.28	663.20	805.98
Separation and Stabilization	5612.30	318.44	10146.47	12765.70
Material Handling	516.94	41.90	13.34	18.99
Integrated control and safety systems	752.00	7.20	24.25	60.12
Oily Water Treatment Systems	8606.93	315.68	2648.01	3200.97
Fire Water and Foam Systems	1465.39	33.10	1196.12	1735.75
Fuel Gas System	35.30	1.81	130.88	156.17
High Pressure Sea Water System	300.67	12.74	1879.58	0.00
Fresh Water Systems	200.00	25.00	1378.00	0.00
Diesel System	2.22	0.29	133.02	173.45
Chemical Injection Systems	81.14	2.72	134.45	70.11
Inert Purge System	131.15	4.59	63.53	76.04
Flare, Vent and Blowdown Systems	160.02	56.11	169.68	202.50
Seawater Systems (Low to Medium Pressure)	0.00	0.00	478.02	570.97
Heating Systems	1464.09	240.76	2229.33	2795.09
Battery System and Uninterruptible Power Supply	107.06	1.94	2.02	2.00
Open Drain System	57.06	5.18	1126.19	1343.87
Compressed Air Systems	135.23	7.65	78.35	96.40
Main Power Generation and Distribution 13.3kV	32412.99	586.83	611.74	606.38
Halon/CO2 Systems	533.70	12.06	435.63	632.16

around 243 days in detailed design versus 260 for FPSO α , the opportunity cost of standardization for construction is estimated as in Section 5.2.2 as

$$c' = \frac{0.145 [103.039 - (0.50)(114.344)]}{243 - 130} \approx \$58,000/\text{day}$$

The required detailed design time for a partially standardized FPSO β , $T_{\beta,\alpha}^{DD}$, is then

$$T_{\alpha\beta}^{DD} = T_{\beta_0}^{DD} - (c')^{-1} \Delta C(\mathbf{x}^\alpha, \mathbf{x}^\beta)$$

Where $T_{\beta_0}^{DD}$ is the detailed design time required for an individually optimized FPSO β_0 . For example, the detail design time saved by re-using only system 23 in FPSO β can be estimated as $(0.145)(2,921)/58 \approx 7$ days.

Reduction in fabrication time is estimated individually for each system to be around 2% for the second FPSO. The impact of such a reduction is then calculated based on the fabrication and installation schedule. Essentially, if the fabrication of a system on the critical path is expedited, then the overall fabrication schedule is shortened; if not, the fabrication schedule is unaffected. Consider again system 23: For the first FPSO, system 23 requires 250 days fabrication time. A 2% reduction in fabrication time corresponds to 5 days, which does not affect the FPSO delivery schedule at all (Figure 5-9). The total reduction in construction time for system 23, including detailed design and fabrication, will be $7 + 5 = 55$ days, of which only 7 will be actually materialized (if only system 23 is standardized). On the other hand, combined with other fabrication time reductions, the remaining 5 days may be important. To capture these effects, the construction schedule is solved for each standardization strategy.









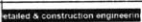

ID	Task Name	Duration	
1	Detailed & construction engineering	130d	 130d
2	Power generation (systems 80, 85 & 72)	270d	 270d
3	Sulphate reduction (system 44)	290d	 290d
4	Chemical injection (systems 42 & 61)	180d	 180d
5	Water injection (systems 50 & 51)	200d	 200d
6	HP separation (system 20)	230d	 230d
7	LP separation & metering (system 73)	250d	 250d
8	HP compression (system 23)	250d	 250d
9	Gas dehydration / fuel gas (system 45)	200d	 200d
10	HP flare (systems 43 & 64)	210d	 210d
11	Laydown / misc (systems 41, 56, 62, 63, 70, 71, 83, 70, 71, 86 & 87)	160d	 160d
12	Installation & integration	160d	 160d

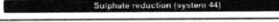
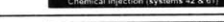
Figure 5-9: FPSO α construction schedule. All links are start-to-start with lag.

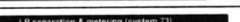
5.3 Screening of platform strategies

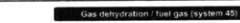
The next step after quantifying the measurable effects of partially standardizing FPSO β , is to screen standardization strategies between FPSOs α and β that maximize the associated benefits. This is done as described in chapter 3, by first building an SDSM representative of a “base” design \mathbf{x}^* and then explore how removing “sensitivities,” i.e., SDSM entries, increases the set of systems that can potentially be standardized among designs \mathbf{x} and \mathbf{x}^α and among designs \mathbf{x}^* and \mathbf{x}^β . As shown in chapter 3, it will then be possible to standardize these systems among FPSOs α and β as well.

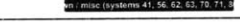
For this design study, the SDSM was built considering the design of FPSO α , (Figure 5-10)⁷ i.e.,

$$\mathbf{x}^* \equiv \mathbf{x}^\alpha$$

Identifying FPSO α as the base design is not necessary but implies that for this analysis FPSO α is optimized according to strategy 1 (see p.109), and the standardization strategies explored correspond to any standardization opportunities that can be salvaged for FPSO β . Taking $\mathbf{x}^* \neq \mathbf{x}^\alpha$ would imply that both FPSOs α and β can be optimized simultaneously so as to maximize the value of the entire program (strategy 3a).

5.3.1 The low-hanging fruit

Some sets of systems will be generally decoupled from other systems even before any sensitivities are removed from the SDSM. These are the systems that can be standardized between FPSOs α and β anyway, i.e., the “low-hanging fruit.” If they are not standardized in reality, this may be for non-technical reasons that make their customization optimal in a larger business context.

These standardization opportunities can be easily identified with a direct application of the IDR algorithm to FPSO α 's SDSM. The result is shown in Figure 5-11. The selection of standardized systems is intuitive with the imposed changes in functional requirements. It involves systems that are completely irrelevant to the production facilities (such as living quarters), or systems that are uncoupled with the changes in functional requirements (such as systems related to oil processing).

5.3.2 Compromise strategies

In general, standardization requires compromise, because systems and components are normally designed to exactly match the specification requirements imposed by other components they are coupled with. Removing SDSM entries requires that these couplings are broken, i.e., that “slack” is added to the design of systems and components.⁸ In principle,

⁷This cannot be inferred from any data appearing here. It is a matter of convention and agreement among the members of the multi-disciplinary team that models the SDSM.

⁸In this design study, all compromise is required only of the designers of FPSO β , since the original SDSM corresponds exactly to FPSO α . Given the differences in functional requirements prescribed in the outset

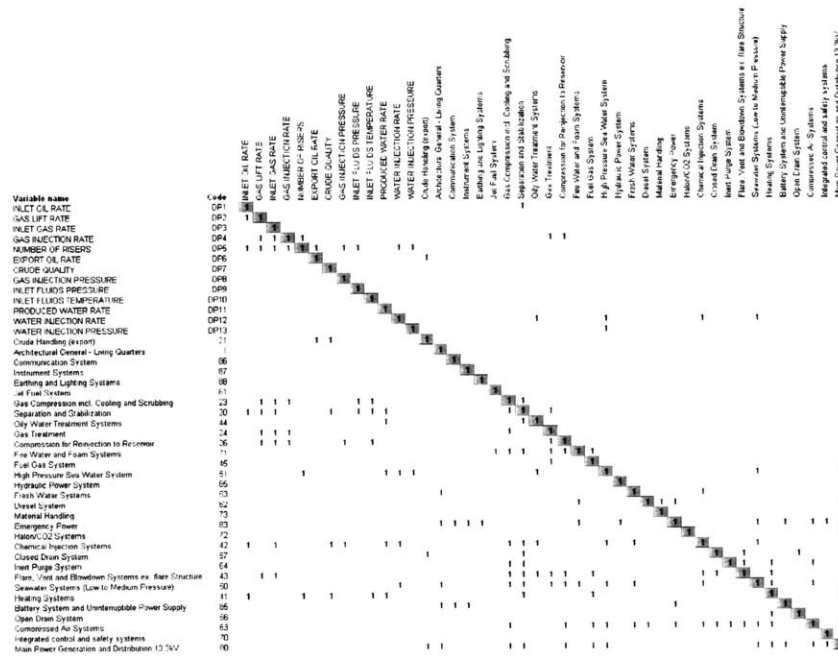

Figure 5-10: Original SDSM for FPSO α

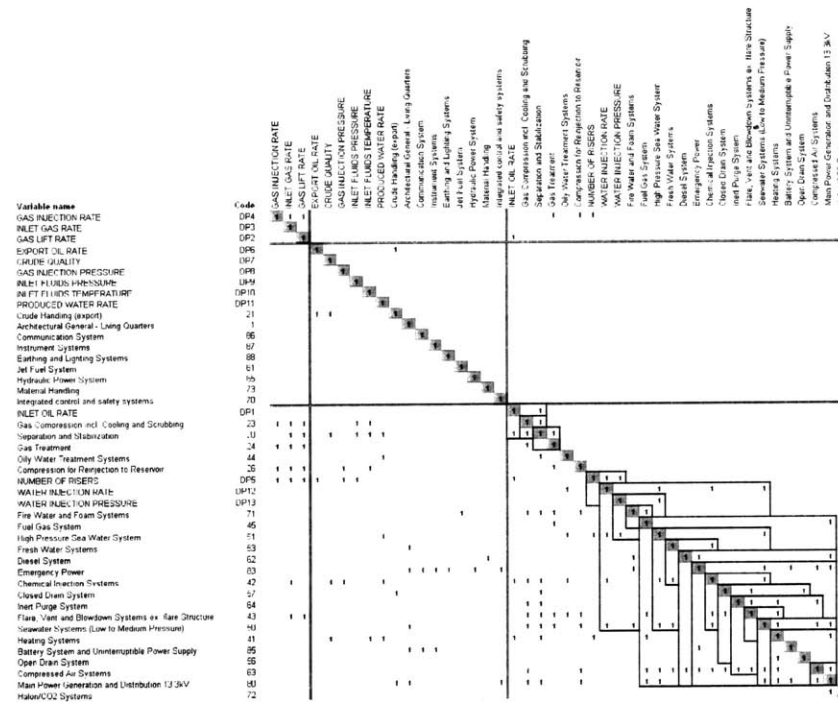

Figure 5-11: Partitioned SDSM for FPSO α , showing standardized systems according to strategy 0 (no entries removed).

the local “slack” imposed on the design of individual systems should be minimized; therefore, standardization strategies should be explored that minimize the number of SDSM entries removed. Equivalently, the maximum number of standardized components for a given number of entries removed should be sought. This is achieved using the IDR algorithm for alternative combinations of SDSM entries removed.

At the same time, standardization strategies should aim at maximizing value. Given that the value of all the alternative strategies that may be chosen when FPSO β is developed depend on the uncertainties at that time, so are unknown beforehand, standardization strategies should be screened for the closest proxies for value that do not depend on uncertain parameters (see Section 5.3). These are the strategies that maximize the functions $g_1 \dots g_5$. Therefore, screening alternative standardization strategies for FPSO β amounts to finding the Pareto front of standardization strategies that maximize functions $g_1 \dots g_5$.

Finding these points is formally a multi-objective optimization problem on a 5-dimensional Pareto front.⁹ These Pareto fronts are shown pair-wise in the matrix of plots in Figure 5-12. Each plot shows 2000 simulated standardization strategies. Each point on the plots, i.e., each strategy, was obtained by randomly removing entries from the “customized systems” quadrant of the SDSM in Figure 5-11 (i.e., the south-east quadrant), running the IDR algorithm on the resulting matrix, and calculating functions $g_1 \dots g_5$ for the set of standardized systems. The plots show 165 non-dominated solutions, shown as black squares instead of grey circles, i.e., strategies for which any improvement to one of the objectives implies a deterioration of another objective.¹⁰ Notice that most of these strategies are very similar, so they can be grouped in a smaller number of representative standardization alternatives. For illustration, 16 strategies (out of 165) were selected, and the values of the functions $g_1 \dots g_5$ corresponding to each are shown in Table 5.7.

The plots in Figure 5-12 are rich in qualitative and quantitative information on alternative standardization opportunities. The plots of g_2 against g_3 and g_4 against g_5 show a clear linear relationship between the two metrics. This is not surprising in this case, since their relationship was modeled to be linear (equations 5.2 and 5.4, and Sections 5.2.3 and 5.2.4). This implies no trade-off between these effects. Moreover, the percent-wise standardization effect on construction time (corresponding to detailed design and fabrication) is negligible according to the range of g_5 : all alternatives provide a reduction of about 5%. Whilst this can be a significant and valuable reduction in construction time, it does not vary much between alternative strategies. This indication could be used to drop this screening criterion altogether, narrowing down the dominant standardization strategies. Finally, the plots in

(see Figure 5-3), this is not unreasonable: it broadly implies that the gas handling system will be optimized for FPSO α to accommodate the higher capacity requirements, and then it may be utilized on FPSO β as well, if the standardization benefits at the time justify it.

⁹In this work, the design space was searched using Monte-Carlo simulation, and not optimization.

¹⁰On a two-dimensional Pareto plot, the Pareto-optimal points usually lie on an “edge” of the set all the points in the plot; here, they do not. This is because the Pareto-front is 5-dimensional, so a point that seems “in the middle” of others in one plot, is on the edge of the region of points on another plot.

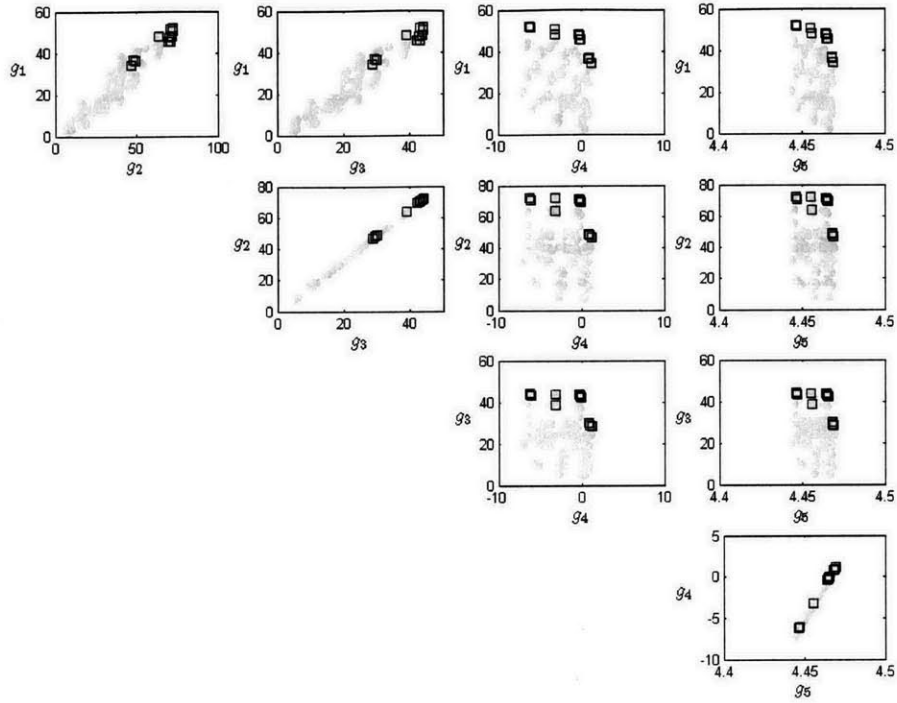

Figure 5-12: 2000 standardization strategies (produced with Monte-Carlo simulation). Black square markers show the Pareto-optimal strategies. Y-axes and x-axes on off-diagonal plots are % benefit for the g functions.

Figure 5-12 indicate a trade-off between capital cost reduction for FPSO β , i.e., g_2 and the other standardization effects: re-using the design of a system from FPSO α means that it will be oversized for FPSO β .

5.4 Valuation of standardization program

The application of the IDR methodology achieved screening the design space for standardization of FPSO β from 2^{38} to 16 representative Pareto-optimal strategies that maximize measurable effects on design and construction cost and time, and operational expenses. The program's flexibility is that each of these 16 alternatives might be optimally developed in a certain future state of the world. To make the presentation more tractable, the 16 strategies are screened further down to 5, picked manually using the data in Table 5.7 to be representative of the Pareto fronts in Figure 5-12. These are strategies 1, 2, 9, 13 and 14, and are shown in Table 5.8.

The flexibility valuation methodology introduced in Chapter 4 is used on these 5 alternatives to estimate the value of the program starting with FPSO α (Figure 5-13). Based on the model in chapter 4, the expected value of each state of owning and operating FPSOs

Table 5.7: Measurable standardization effects: $g(\%)$ functions for $\beta_1 \dots \beta_{16}$

Strategy	g_1	g_2	g_3	g_4	g_5	Strategy	g_1	g_2	g_3	g_4	g_5
β_1	47.43	70.08	42.7	-0.22	4.46	β_9	34.18	46.84	28.54	1.18	4.47
β_2	52.04	72.43	44.13	-6.23	4.45	β_{10}	48.17	63.72	38.82	-3.17	4.46
β_3	51.76	70.79	43.13	-6.08	4.45	β_{11}	50.51	72.38	44.1	-3.2	4.46
β_4	45.55	70.83	43.16	-0.16	4.47	β_{12}	51.89	72.38	44.1	-6.23	4.45
β_5	36.39	49.21	29.98	0.83	4.47	β_{13}	36.52	47.89	29.18	0.98	4.47
β_6	47.85	71.79	43.74	-0.37	4.46	β_{14}	47.85	71.79	43.74	-0.37	4.46
β_7	51.89	72.38	44.1	-6.23	4.45	β_{15}	51.76	70.79	43.13	-6.08	4.45
β_8	45.51	69.36	42.26	-0.01	4.47	β_{16}	52.04	72.43	44.13	-6.23	4.45

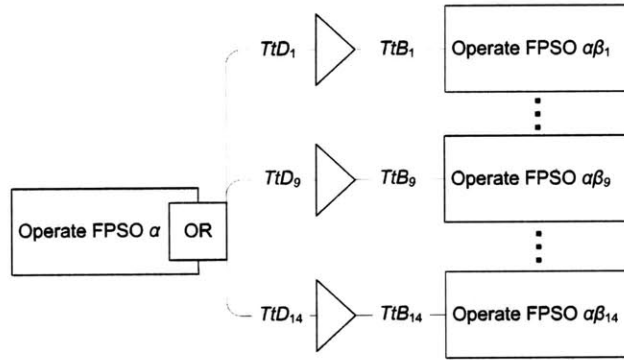

Figure 5-13: FPSOs α and β program development decisions

$\beta_1, \beta_2, \beta_9, \beta_{13}, \beta_{14}$ is given by equation 4.2, re-written below.

$$E[V_\alpha(\mathbf{s}_0)] = \sum_{t=t_0}^T e^{-r_\alpha t} E[CF(\mathbf{x}^\alpha, \mathbf{s}_t)] \quad (5.6)$$

$$E[V_{\alpha\beta_i}(\mathbf{s}_0)] = \sum_{t=t_0}^T e^{-r_i t} E[CF_i(\mathbf{s}_t)] \quad \text{for } i = 1, 2, 9, 13, 14 \quad (5.7)$$

where r_i is an appropriate discount rate for each combination of assets $\alpha\beta_i$; $CF_i(\mathbf{s}_t)$ is the per-period cash flow generated by operation of asset α and β_i simultaneously; r_α is the appropriate discount rate for FPSO α ; and $CF(\mathbf{x}^\alpha, \mathbf{s}_t)$ is the cash flow generated by operation of FPSO α alone.

The timing options to construct each of $\beta_1, \beta_2, \beta_9, \beta_{13}, \beta_{14}$ are written according to equation 4.3 as

$$F_{\alpha\beta_i}(\mathbf{s}_t) = \max \left[I_{\alpha\beta_i}(\mathbf{s}_t), e^{-r_{\alpha i} \delta t} E[F_{\alpha\beta_i}(\mathbf{s}_{t+\delta t})] \right] \quad \text{for } i = 1, 2, 9, 13, 14 \quad (5.8)$$

where $F_{\alpha\beta_i}(\mathbf{s}_t)$ denotes the value of the option to construct β_i ; $I_{\alpha\beta_i}(\mathbf{s}_t)$ is the intrinsic value of this option, i.e., the value of immediate exercise; $r_{\alpha i}$ is an appropriate discount rate for

Table 5.8: Standardization strategies: standardized systems between FPSOs α and β (5 selected strategies)

System name	β_1	β_2	β_9	β_{13}	β_{14}
Crude Handling (export)	•	•	•	•	•
Architectural General - Living Quarters	•	•	•	•	•
Communication System	•	•	•	•	•
Instrument Systems	•	•	•	•	•
Jet Fuel System	•	•	•	•	•
Gas Compression incl. Cooling and Scrubbing		•			
Separation and Stabilization	•	•			•
Material Handling	•	•	•	•	•
Integrated control and safety systems	•	•	•	•	•
Oily Water Treatment Systems	•	•	•	•	•
Fire Water and Foam Systems	•	•		•	•
Fuel Gas System	•	•	•	•	•
High Pressure Sea Water System	•	•		•	•
Fresh Water Systems	•	•	•	•	•
Diesel System	•	•	•	•	•
Chemical Injection Systems		•		•	•
Inert Purge System	•	•		•	•
Flare, Vent and Blowdown Systems		•			•
Seawater Systems (Low to Medium Pressure)		•			
Heating Systems	•	•	•	•	•
Battery System and Uninterruptible Power Supply	•	•	•	•	•
Open Drain System	•	•	•	•	•
Compressed Air Systems	•	•		•	•
Main Power Generation and Distribution 13.3kV	•	•	•	•	•
Halon/CO2 Systems	•	•	•	•	•

risk in the future value of the option to transition from a state of operating FPSO α to operating α and β_i simultaneously.

Given the construction time lag, the value of immediate exercise of this option is given according to equation 4.5, re-written below for the construction of β_i

$$\begin{aligned}
 I_{\alpha\beta_i}(\mathbf{s}_t) = & e^{-r_i T t B_i} E[V_{\alpha\beta_i}(\mathbf{s}_{t+t_b})] \\
 & - e^{-r_\alpha T t B_i} E[V_\alpha(\mathbf{s}_{t+TtB})] \\
 & - e^{-r_c T t B_i} E[C_{\alpha\beta_i}]
 \end{aligned} \tag{5.9}$$

where r_c denotes an appropriate discount rate for the construction cost risk.

Finally, the value of the choice option among the 5 different designs is written according to equation 4.6

$$\begin{aligned}
 OR(\mathbf{s}_t) = \max \{ & \max_i (e^{-r_{F_i} T t D_i} E[F_{\alpha\beta_i}(\mathbf{s}_{t+TtD_i})] - e^{-r_f T t D_i} D_i), \\
 & e^{-r_{OR} \delta t} E[OR(\mathbf{s}_{t+\delta t})]
 \end{aligned} \tag{5.10}$$

Table 5.9: Estimated costs for 5 selected standardization programs (based on current prices of oil, gas and steel).

State	Annual spares cost \$1,000	FEED cost \$1,000	FEED time, days	Constr. cost \$1,000	Constr. time, days
$\alpha\beta_0$	3,771	18,139	330	103,039	554
$\alpha\beta_1$	1,982	5,427	189	103,263	529
$\alpha\beta_2$	1,808	5,000	184	109,456	529
$\alpha\beta_9$	2,482	9,643	236	101,820	529
$\alpha\beta_{13}$	2,394	9,452	234	102,032	529
$\alpha\beta_{14}$	1,966	5,117	186	103,417	529

where r_{Fi} , $i = 1, 2, 9, 13, 14$ denotes an appropriate discount rate for the future value of the construction option, $F_{\alpha\beta_i}$, obtained by design.

Even though notation becomes unwieldy, the essence of equations 5.6 to 5.10 is simple. They represent a system to be solved recursively for various future values of the uncertainties. This system is constructed by simply combining the equations that represent the “option building blocks” introduced in 4.2, so that they correspond to the development decisions shown in Figure 5-13. They are solved using the valuation methodology presented in Section 4.3.

The uncertainties s_t for this design study are assumed to be the price of oil (s_t^{oil}), gas (s_t^{gas}) and steel (s_t^{stl}), with “current” values taken to be representative of the market late 2005,

$$\{s_0^{oil}, s_0^{gas}, s_0^{stl}\} = \{56, 9, 143\} (\$/bbl, \$/mscf, \$/ton)$$

and expected growth rates equal to $\{0.12, 0.10, 0.06\}$ respectively. The covariance matrix of the three factors was estimated based on annual data over the past 20 years:

$$COVAR = \begin{bmatrix} 0.0289 & 0.0429 & 0.0026 \\ 0.0429 & 0.1467 & 0.0190 \\ 0.0026 & 0.0190 & 0.0463 \end{bmatrix}$$

5.4.1 Valuation results

Equations 5.6, 5.7, 5.8, 5.9 and 5.10 are solved in reverse order twice:¹¹ once, using the valuation algorithm introduced in Chapter 4 with the risk-adjusted expected growth rates for the underlying uncertainties; and a second time using the risk-neutral dynamics for the same factors, i.e., assuming that they grow at the risk-free rate. The two sets of results should be different, since the values of the two phases of development (FPSO α and FPSO α

¹¹Both solutions used the same 50,000 paths and 10,000 paths per bin on average along each dimension. The planning horizon was taken to be 10 years and the time increment 1 year. The risk-free rate was assumed $r_f = 5\%$.

and β together) are not perfectly correlated because only FPSO β produces gas. Assuming that the assumptions underlying risk-neutral valuation hold for these uncertain factors, the second valuation should be considered formally correct. However, if both valuation methodologies indicate that the same standardization alternative for FPSO β should be pursued and if they rank the design solutions the same way, then the risk-neutral valuation and the proposed methodology are equivalent for design purposes.

First, the value of the future cash flows of state α is calculated, given an assumed accepted discount rate $r_\alpha = 20\%$. Then the value of each of the states $\beta_1, \beta_2, \beta_9, \beta_{13}, \beta_{14}$ is found for each representative vector of the uncertainties at each time, by varying the risk compensation depending on the risk in future values. These values are shown in Table 5.10 as $V_{\alpha\beta}$, and their differences are due to the differences in fixed operating expenses for each FPSO β . The timing options to develop each of the FPSOs $\beta_1, \beta_2, \beta_9, \beta_{13}, \beta_{14}$ based on FPSO α are calculated using equation 5.8, and are shown in Table 5.10 as $F_{\alpha\beta}$. These values include the differences between $\beta_1, \beta_2, \beta_9, \beta_{13}, \beta_{14}$ in construction cost and time. Notice in Table 5.10 that both the risk-adjusted and the risk-neutral valuation rank the alternative strategies the same way.

Table 5.10: Value of states $\alpha\beta_i$

Assets	$V_{\alpha\beta}$	
	risk-neutral	risk-adjusted
α	8,638,000	10,067,000
$\alpha\beta_1$	24,998,000	27,361,000
$\alpha\beta_2$	25,018,000	27,380,000
$\alpha\beta_9$	24,943,000	27,305,000
$\alpha\beta_{13}$	24,953,000	27,315,000
$\alpha\beta_{14}$	25,000,000	27,362,000

The timing options are valued accordingly, and the risk-neutral and risk-adjusted results are compared in Table 5.11. Again, notice that both valuation methodologies rank alternative standardization strategies the same way.

Table 5.11: Value of construction options for states $\alpha\beta_i$

Assets	$F_{\alpha\beta}$	
	risk-neutral	risk-adjusted
$\alpha\beta_1$	11,156,000	10,485,000
$\alpha\beta_2$	11,168,000	10,494,000
$\alpha\beta_9$	11,121,000	10,460,000
$\alpha\beta_{13}$	11,127,000	10,464,000
$\alpha\beta_{14}$	11,157,000	10,486,000

The value of the choice option associated with state α is calculated using equation 5.10, and found equal to $OR = 9,311,000$ using risk-neutral valuation and $OR = 8,849,000$ using real-world dynamics. This value corresponds to the value of strategy 3b (p. 110), whereby the standardization decision is made at the point FPSO β is developed. This value is inherent to the value of the entire program, i.e., FPSO α as of the time of the valuation. The net present value of the program, and thus the criterion for the design of FPSO α , is the value of the choice option, plus the value of its intrinsic cash flows (Table 5.10), less the construction costs for FPSO α .

To isolate the value of flexibility to choose standardization strategies, an additional analysis is performed. The value of the compound option is calculated, to first design and then construct each of $\beta_1, \beta_2, \beta_9, \beta_{13}, \beta_{14}$, without the flexibility to choose amongst them. The results are shown in Table 5.12. The value of each of these options corresponds to “committing” strategies 3a. Observe that the value of the choice option found above, $OR = 9,311,000$ (or $OR = 8,849,000$), is equal to the value of the option to develop standardization alternative β_{16} . This implies that the option to defer the choice of standardization alternative, i.e., the difference between strategies 3a and 3b, is zero, and that selection, design and development of FPSO β is immediately exercised.

Table 5.12: Option to design and develop states $\alpha\beta_i$

Assets	$OR_{\alpha\beta}$	
	risk-neutral	risk-adjusted
β_1	7,853,000	7,458,000
β_2	7,725,000	7,334,000
β_9	9,311,000	8,849,000
β_{13}	9,244,000	8,784,000
β_{14}	7,755,000	7,364,000

5.5 Summary

This chapter presented an application of the methodologies proposed in this thesis to the design of programs of two sequential Floating Production, Storage and Offloading (FPSO) units. The purpose of this study was to demonstrate the calculation of value added to the entire program, by the opportunity to base the design of select systems in the second asset on the existing designs of the first. In principle, this value has a flexibility component, stemming from the fact that the choice of alternative standardization design can be delayed until the second asset is designed.

The two-step methodology was used for the screening and valuation of the flexibility and real options embedded in the program. The screening of alternative second-phase designs was based on the estimated reduction in design and construction cycle time, the estimated

effect on design and construction costs, and the reduction on fixed operating expenses for the program; i.e., screening was based on measurable effects at the time of the first development. This screening resulted in 165 Pareto-optimal standardization alternatives, obtained using Monte-Carlo simulation. Valuation was performed on only 5 of these 165 alternative designs for illustrative purposes. It was found that for the particular data, which was partly real and partly modified, the flexibility to delay the design decision for the second FPSO was not valuable, because the second development was optimally designed and developed immediately. On the other hand, it was shown that for this design study, the valuation based on the proposed methodology indicates the correct design alternative, despite the fact that it is wrong from a diversified investor's viewpoint.

Chapter 6

Conclusions and future work

6.1 Summary

This thesis introduces a framework and methodologies that enable engineering management teams to assess the value of flexibility in programs of standardized systems, thus bridging a gap in the literature and practice between platform design and design for flexibility, particularly for large-scale, capital intensive systems implemented only a few times over the medium term. The main hypothesis for this work is that platform design creates and destroys future flexibility at the same time and in different ways, so the two paradigms can be competing in some ways and complementary in others. Therefore, the need was identified for a structured process that enables the practical simultaneous consideration for platform and flexibility design. The need for such a process is driven by the high potential value of both platforms and flexibility.

The approach taken in this thesis follows a two-step rationale: first, one must frame the flexibility one perceives to have available to them for the future, i.e., express their “real options” for expanding, contracting, improving or otherwise modifying an existing system. The second step is to value the existing design, considering how much flexibility it allows for these modifications. In the context of standardization in large-scale systems, the evolution of a program of projects is perceived as the design and development of a new asset which is partially standardized with existing systems in place.

The two-step rationale is not novel *per-se*. The contribution of this work lies in improving this two-step process in a structured and systematic way that enables the exploration of platform design opportunities and flexibility for programs of large-scale systems. Platform design in large-scale projects is inherently a multi-disciplinary effort, subject to multiple uncertainties and qualitative and quantitative external inputs. To the best of the author’s knowledge, no such design management methodology exists to date, that is (a) suitable for large-scale, complex projects; (b) modular, with modules that are based on proven concepts and practices; (c) open to inter-disciplinary and qualitative expert opinion; (d) is effectively a basis for communication between the traditionally distinct disciplines of engineering and

finance.

To this end, this thesis made three contributions:

- A novel, inter-disciplinary methodology and algorithm for screening potential standardization alternatives at various levels of system aggregation. Because it identifies the standardized system components that should determine the design of the customized ones, that are insensitive to changes in functional requirements between variants, the methodology is called Invariant Design Rules (IDR).
- A graphical representation of common decisions in engineering design and development, and a one-to-one correspondence of these decisions to real option formulations. For the solution of the model, a simulation-based real options valuation algorithm for these decisions is developed. The algorithm involves simulation of the real-world probability dynamics of multiple uncertainties and invokes equilibrium, rather than no-arbitrage arguments for options pricing. The practical contribution of this methodology is potentially very significant: the methodology and algorithm offer solutions to the major impediments to widespread use of real options theory in engineering design applications, i.e., lack of an unambiguous modeling language, and the no-arbitrage principles.
- Finally, this thesis demonstrated a use of the developed methodologies in an FPSO design study. The contribution lies in a subtlety: whereas existing screening methodologies rely on criteria that depend on future uncertainty, the methodology presented in chapter CH5 does not. Instead, it screens potential future standardized developments based on criteria that are measurable as of the time of the screening. As a result, each of the alternative second-phase standardization strategies (denoted as FPSOs $\beta_{13}, \beta_{24} \dots \beta_{67}$ in chapter 5) will surely be the optimal strategy in some future state of the world. The flexibility created by the first FPSO design is the ability to choose from these standardization strategies later, depending on how uncertainty unfolds.

6.2 Future research

This work can be extended in many directions, some of more academic interest and others of more practical value. On a practical level, the valuation methodology can be used as an objective function for the optimization of the entire program. As another application, the two-step methodology can be used to trade-off a-priori commitment with future flexibility in a program of projects (see footnote 2, p. 111). Possible extensions to the IDR methodology relate to its being used to guide the automatic selection of standardization alternatives. These future research directions are examined next.

6.2.1 Flexibility-based optimization and value created

Recall Section 5.1.2, p.108, and the analysis on alternative program development standardization strategies. A distinction was drawn among a strategy of no standardization (strategy 1, ensuring that both FPSOs are optimized around the conditions at the time of their development), and a strategy of smart standardization (strategy 3), where the economic benefits from re-using existing designs are traded-off against the benefits from full customization. The latter strategy could be planned either as a prior commitment as to which ones the standardized components may be (approach 3a), or with flexibility, where the standardization decision is made when the second asset is developed (approach 3b).

The difference between approaches 1 and 3b is subtle. Strategy 1 implies the optimization of the first asset without consideration for possible expansion with the second. According to approach 3b, the first asset is designed in anticipation of the second. Their difference is the total value that can be created by standardization. An interesting question concerns the value of *flexibility* that can be created by standardization. Specifically,

Assuming that the set of alternative standardization choices available to the designers of β can be significantly affected by the design of α , how much value from flexibility can the developer create by using approach 3b (instead of 1) to optimize FPSO α ?

The value of flexibility of a design optimized according to approach 3b is $V_{3b}(\alpha_{3b}) - V_{3a}(\alpha_{3b})$; the value of flexibility of a design optimized using approach 1 is $V_{3b}(\alpha_1) - V_{3a}(\alpha_1)$. The value of flexibility created by optimizing α with a valuation method that accounts for flexibility (e.g., approach 3b) is the difference between these two quantities:

$$\text{Value of flexibility created} = [V_{3b}(\alpha_{3b}) - V_{3a}(\alpha_{3b})] - [V_{3b}(\alpha_1) - V_{3a}(\alpha_1)]$$

If this difference is larger than the *apparent* the penalty in FPSO α because it is not optimized individually, i.e., the difference

$$\text{Apparent standardization penalty for FPSO } \alpha = V_1(\alpha_1) - V_1(\alpha_{3b})$$

then the developer using approach 1 to develop and value FPSO designs is forfeiting value of flexibility. In other words, not only does approach 1 not give the correct value of FPSO α , it also leads to suboptimal design decisions.

A proposed extension of this research, and a way to potentially change the prevalent design paradigm so that it considers flexibility, is to apply this simple arithmetic to existing case studies. This can serve to demonstrate in a systematic way, how much value is forfeited in current practice because flexibility is not considered.

6.2.2 IDR-based platform optimization

Section 2.4 explained that the selection of platform components in a system of n distinct modules is a combinatorial problem of size 2^n , and the recent focus of interesting research.

Specifically, Simpson & D’Souza (2002) and Simpson & D’Souza (2003) propose the optimization of platform architectures and variants in a single stage using genetic algorithms. The genome in the genetic algorithm codifies the design variables for each variant in the product family, and includes a “control vector” of ones and zeros, equal to the length of the design vector for each variant. The control vector indicates whether each design variable is shared among variants, and invokes corresponding constraints in the system model.

This approach has two problems. Firstly, it runs the risk of indicating that platform components are variables “belonging” to very different physical components of the system. Secondly, it makes no use of technical or constraint information from the technical model of the variants; in effect, the algorithm searches the entire combinatorial space of potential platforms.

As an extension to the platform optimization literature, the IDR algorithm can be coupled with the genetic algorithm proposed by Simpson & D’Souza (2003) to narrow down the search of alternative platform strategies. If derivative information is also available from the system model, the SDSM can also be calculated automatically, minimizing the need for engineering input.

6.2.3 Application: trading-off commitment and flexibility

In many practical contexts, including FPSO program design to a certain extent, the design study presented in Chapter 5 is contrived, mainly by assuming that benefits can be realized for the second development, even if there has been no prior commitment to standardization. In reality, committing *a-priori* to design decisions that can be normally postponed can be a good strategy, e.g., because some of the value of standardization can be transferred to the developer only if its suppliers receive prior guarantee of future orders. Therefore, there is a trade-off between commitment to a standardized strategy (which yields standardization benefits) and flexibility to choose standardization strategies in the future.

This trade-off is often captured in option-like contract clauses between the developer and suppliers. Effectively, these clauses swap a fixed “large-quantity” discount for advance orders, against the expected losses to the supplier if the developer does not follow up with the standardization strategy. This trade-off is of great practical interest to large-scale development organizations, because it allows them to consider not only technical and economic performance, but also supply chain and organizational issues that drive program development decisions. The framework presented in this thesis can be extended in this direction, to achieve: (a) the simple valuation of these option clauses; (b) more importantly, their optimization simultaneously with the technical design.

Bibliography

- R. Adner & D. Levinthal (2004). 'What is not a real option: considering boundaries for the application of real options in business strategy'. *Academy of Management Review* **29**(1):74–85.
- S. Ahmed & N. V. Sahinidis (2003). 'An Approximation scheme for stochastic integer programs arising in capacity expansion'. *Operations Research* **51**(3):461–471.
- M. Amram & N. Kulatilaka (1999). *Real options: managing strategic investment in an uncertain world*. Harvard Business School Press, Cambridge, MA.
- L. Andersen (2000). 'A simple approach to the pricing of Bermudan swaptions in the multifactor LIBOR market model'. *Journal of Computational Finance* **3**:5–32.
- W. Archambeault (2002). 'For lease or sale: Telecom hotels'. Boston Business Journal. <http://boston.bizjournals.com/boston/stories/2002/09/02/story2.htm>.
- T. Arnold & T. Crack (2003). 'Option pricing in the real world: a generalized binomial model with applications to real options'. In *7th Annual Real Options Conference*, Washington, DC.
- C. Baldwin & K. Clark (2000). *Design Rules I: The Power of Modularity*. MIT Press, Cambridge, MA.
- J. Barraquand & D. Martineau (1995). 'Numerical Valuation of High Dimensional Multi-Variate American Securities'. *Journal of Financial and Quantitative Analysis* **30**(3):383–405.
- J. Bengtsson (2001). 'Manufacturing flexibility and Real Options: A Review'. *International Journal of Production Economics* **7**:213–224.
- Berwanger (2004). *Oil and Gas Manager, User Manual*. Berwanger Inc., Houston, TX.
- T. Bjork (2003). *Arbitrage Theory in Continuous Time*. Oxford University Press, Oxford, UK.
- P. Boer (2002). *The Real Options Solution*. John Wiley and Sons, New York, NY.

- A. Borison (2003). 'Real Options Analysis: Where are the Emperor's Clothes?'. In *7th Annual International Conference on Real Options*, Washington, DC.
- R. Botter & L. Fortuin (2000). 'Stocking strategy for service parts, a case study'. *International Journal of Operations & Production Management* **20**(6):656–674.
- P. Boyle (1977). 'Options: a Monte-Carlo Approach'. *Journal of Financial Economics* **4**:323–338.
- P. Boyle, et al. (1997). 'Monte Carlo methods for security pricing'. *Journal of Economic Dynamics and Control* **21**:1267–1321.
- M. Brennan & E. Schwartz (1985). 'Evaluating Natural Resource Investments'. *Journal of Business* **58**(2):135–157.
- M. Broadie & J. Detemple (1997). 'The valuation of American options on Multiple Assets'. *Mathematical Finance* **7**(3):241–286.
- M. Broadie & P. Glasserman (1997). 'Pricing American-style securities using simulation'. *Journal of Economic Dynamics and Control* **21**(8):1323–1352.
- T. Browning (2001). 'Applying the Design Structure Matrix to System Decomposition and Integration Problems: A Review and New Directions'. *IEEE Engineering Management* **48**(3):292–306.
- D. Capozza & Y. Li (1994). 'The Intensity and Timing of Investment: The Case of Land'. *American Economic Review* **84**(4):889–904.
- P. Carr (1988). 'The Valuation of Sequential Exchange Opportunities'. *Journal of Finance* **XLIII**(5):1235–1256.
- A. Chen, et al. (1998). 'Evaluating complex manufacturing processes as multiple switching options'. *Quarterly Review of Economics and Finance* **38**:651–674.
- P. D. Childs, et al. (1996). 'Mixed Uses and the Redevelopment Option'. *Real Estate Economics* **24**:317–339.
- T. Copeland & V. Antikarov (2001). *Real Options, a Practitioner's Guide*. TEXERE LLC, New York, NY 10055.
- G. Cortazar, et al. (2001). 'Optimal exploration investments under price and geo-technical uncertainty: a real options model'. *R & D Management* **31**(2):180–189.
- J. Cox, et al. (1979). 'Option Pricing: A Simplified Approach'. *Journal of Financial Economics* **7**:229–263.

- B. Cullimore (2001). 'Beyond point design evaluation'. ASME Fluids Engineering Division, Summer Meeting, <http://www.crtech.com/docs/papers/NewOsummary.pdf>.
- Daewoo Shipbuilding & Marine Engineering Co. Ltd. (2005). 'FPSO standardization program benefits'. Tech. rep., DSME. Internal BP report, confidential.
- Z. Dai & M. Scott (2005). 'Product platform design with consideration of uncertainty'. *SAE 5005* **2005-01-0350**.
- G. Day & D. Montgomery (1983). 'Diagnosing the Experience Curve'. *Journal of Marketing* **47**(2):44–58.
- R. de Neufville (1976). *Airport Systems Planning: a critical look at the methods and experience*. MIT Press, Cambridge, MA.
- R. de Neufville (2002). 'Architecting/Designing Engineering Systems Using Real Options'. MIT, ESD Symposium, <http://esd.mit.edu/symposium/papers>.
- R. de Neufville (2003). 'Real Options: Dealing with Uncertainty in Systems Planning and Design'. *Integrated Assessment Journal* **4**(1):26–34.
- R. de Neufville & S. Belin (2002). 'Airport Passenger Buildings: efficiency through shared use of facilities'. *Journal of Transportation Engineering* **128**(3):201–210.
- R. de Neufville, et al. (2006). 'Valuing Options by Spreadsheet: Parking Garage Case Example'. *ASCE Journal of Infrastructure Systems* **12**(2).
- O. de Weck (2005). *Product Platform and product family design*, chap. 12. Determining Product Platform Extent, pp. 241–302. Springer, New York, NY.
- O. de Weck, et al. (2003). 'Enhancing the Economics of Communications Satellites via Orbital reconfigurations and staged Deployment'. *American Institute of Aeronautics and Astronautics* .
- J. Decamps, et al. (2003). 'Irreversible investment in alternative projects'. In *8th Annual Real Options Conference*, Montreal, CA.
- M. Dias (2004). 'Monte Carlo Simulation of Stochastic Processes'. http://www.puc-rio.br/marco.ind/sim_stoc_proc.html.
- A. Dixit (1995). 'Irreversible investment with uncertainty and scale economies'. *Journal of Economic Dynamics and Control* **19**:327–350.
- A. Dixit & R. Pindyk (1994). *Investment under Uncertainty*. Princeton University Press, Princeton, NJ.

- C. Eckert, et al. (2004). 'Change and Customisation in Complex Engineering Domains'. *Research in Engineering Design* **15**:1–21.
- S. Eppinger & R. Gulati (1996). 'The Coupling of Product Architecture and Organizational Structure Decisions'. MIT Sloan School of Management Working Paper No. 3906.
- S. Eppinger & V. Salminen (2001). 'Patterns of product development interactions'. *International conference on system design, ICED 01 Glasgow*.
- S. Eppinger, et al. (1994). 'A model-based method for organizing tasks In product development'. *Research in Engineering Design-Theory, Application and Concurrent Engineering* **6**:1–13.
- R. Fichman (2004). 'Real options and IT platform adoption: implications for theory and practice'. *Information systems Research* **15**(2):132–154.
- L. Fortuin & H. Martin (1999). 'Control of Service parts'. *International Journal of Operations & Production Management* **19**(9):950–971.
- E. Fricke & A. Schultz (2005). 'Design for Changeability (DfC): Principles to enable changes in systems throughout their entire lifecycle'. *Systems Engineering* **8**(4):342–359.
- K. Fujita, et al. (1999). 'Product Variety Deployment and its optimization under modular architecture and module commonalization'. In *ASME Design Engineering Technical Conferences*, Las Vegas, Nevada.
- D. Gebala & S. Eppinger (1991). 'Methods for analyzing design procedures'. In *ASME 3rd International Conference on Design Theory and Methodology*, pp. 227–233, Miami, FL.
- D. Geltner & N. Miller (2001). *Commercial Real Estate Analysis and Investments*. No. 0-324-13676-5. South-Western Publishing, 5101 Madison Road, Cincinnati, Ohio 4522.
- D. Geltner, et al. (1996). 'Insights on the effect of land use choice: the perpetual option and the best of two underlying assets'. *Journal of Urban Economics* **39**:20–50.
- B. Geppert & F. Roessler (2001). 'Combining Product Line Engineering with Options Thinking'. In *In Proceedings of PLEES01*, Erfurt, DE. Product Line Engineering - The Early Steps.
- P. Ghemawat (1985). 'Building Strategy on the Experience Curve'. *Harvard Business Review* **63**(2):143–151.
- M. Goldberg & A. Tow (2003). *Statistical Methods for Learning Curves and Cost Analysis*. Topics in Operations Research Series. INFORMS.
- J. Gonzalez-Zugasti, et al. (2001). 'Assessing Value in Platformed Product Family Design'. *Research in Engineering Design* **13**:30–41.

- L. Greden & L. Glicksman (2004). 'Architectural Flexibility: A Case Study of the Option to Convert to Office Space'. *8th Annual Real Options Conference* .
- S. Grenadier (1995a). 'Valuing Lease Contracts—a Real Options Approach'. *Journal of Financial Economics* **38**(3):357–378.
- S. Grenadier (1996). 'The strategic exercise of options: Development cascades and overbuilding in real estate markets'. *Journal of Finance* **51**(5):1653–1679.
- S. Grenadier & A. Weiss (1997). 'Investment in technological innovations: an option pricing approach'. *Journal of Financial Economics* **44**:397–416.
- S. R. Grenadier (1995b). 'Flexibility and tenant mix in real estate projects'. *Journal of Urban Economics* **38**:357–378.
- M. Guenov & S. Barker (2005). 'Application of axiomatic design and design structure matrix to the decomposition of engineering systems'. *Systems Engineering* **8**(1):29–40.
- C. Helfat & R. Raubitschek (2000). 'Product sequencing: co-evolution of knowledge, capabilities and products'. *Strategic Management Journal* **21**:961–979.
- B. Henderson (1972). 'Perspectives on Experience'. Boston, MA.
- J. P. Hofer & J. Halman (2004). 'Complex products and systems: Potential from using layout platforms'. *Artificial Intelligence for Engineering Design, Analysis and Manufacturing* **18**:55–69.
- A. Holland, et al. (2000). 'The role of uncertainty in investment: an examination of competing investment models using real estate data'. *Real Estate Economics* **28**(1):33–64.
- K. Hölttä-Otto & K. Otto (2005). *Product Platform and product family design*, chap. 4. Platform concept evaluation, pp. 49–72. Springer, New York, NY.
- E. Hreinsson & K. Jonasson (2003). 'Monte-Carlo based risk analysis in hydroelectric power system expansion planning in the presence of uncertainty in project cost and capacity'. In *38th International UPEC*, Thessaloniki, GR. University of Thessaloniki.
- A. Huchzermeier & C. Loch (1999). 'Evaluating R& D projects as learning options: why more variability is not always better'. *Working paper* .
- J. Hull (2000). *Options, Futures and other Derivatives*. Prentice Hall, New York, NY.
- Hyundai Heavy Industries Co. Ltd (2005). 'FPSO standardization program benefits'. Tech. rep., HHI. Internal BP report, confidential.
- A. Ibanez & F. Zapatero (2004). 'Monte-Carlo valuation of American options through computation of the optimal exercise frontier'. *Journal of Financial and Quantitative Analysis* **39**(2):239–273.

- D. D. Inc (2003). *DVP 2.0 User Manual*. <http://www.ddecisions.org/DDHome.ht>.
- J. Jiao, et al. (2005). 'Flexibility valuation of product family architecture: a real options approach'. *International journal of advanced manufacturing technology* **In print**.
- A. Jose & M. Tollenaere (2005). 'Modular and Platform Methods for Product Family Design: Literature Analysis'. *Journal of Intelligent manufacturing* **16**:371–390.
- K. Kalligeros (2003). 'Framework for the Optimal Design of Facilities for contracting Operations'. In *6th SMESME International Conference, Athens, GR*.
- K. Kalligeros (2004). 'Using real options for engineering systems design: framework, applicability and limitations'. In *Engineering Systems Symposium*. Massachusetts Institute of Technology.
- K. Kalligeros & O. de Weck (2004). 'Flexible Design of Commercial Systems Under Market Uncertainty: Framework and Application'. *10th AIAA/ISSMO Multidisciplinary Analysis and Optimization Conference* **AIAA-2004-4646**.
- E. Kehat & M. Shacham (1973). 'Chemical process simulation programs-2: Partitioning and tearing of system flowsheets'. *Process Technology International* **18**:115–118.
- W. Kennedy, et al. (2000). 'An overview of recent literature on spare parts inventories'. *International Journal of production economics* **76**:201–215.
- Kester (1993). *Turning Growth Options into Real Assets*. Prentice Hall, Engelwood Cliffs, NJ.
- B. Kogut & N. Kulatilaka (2001). 'Capabilities as real options'. *Organization Science* **12**(6):744–758.
- A. Kristjansson & H. Hildre (2004). 'A framework for evaluating platforms in product-developing organizations'. In *7th workshop on product structuring-product platform development*, Goeteborg. Chalmers University of Technology.
- N. Kulatilaka (1993). 'The Value of Flexibility: The Case of the a Dual-Fuel Industrial Steam Boiler'. *Financial Management* **13**(3):271–280.
- N. Kulatilaka (1994). 'Options thinking and platform investments: investing in opportunity'. *California Management Review* .
- A. Kusiak (1990). *Intelligent Manufacturing Systems*. Prentice Hall Press, 200 Old Tappan Road, Old Tappan, NJ 07675, USA.
- A. Kusiak & J. Larson, T.N. and Wang (1994). 'Reengineering of design and manufacturing processes'. *Source Computers and Industrial Engineering archive* **26**(3):521–536.

- H. Li & S. Azram (2002). ‘An Approach for Product Line Design Selection Under Uncertainty and Competition’. *Journal of Mechanical Design* **124**:385–392.
- F. Longstaff & E. S. Schwartz (2001). ‘Valuing American Options by Simulation: A Simple Least-Squares Approach’. *The Review of Financial Studies* **14**(1):113–147.
- T. Luehrman (1998a). ‘Investment Opportunities as Real Options: Getting Started on the Numbers’. *Harvard Business Review* **76**(4):51–63.
- T. Luehrman (1998b). ‘Strategy as a Portfolio of Real Options’. *Harvard Business Review* **76**(5):89–99.
- S. Majd & R. Pindyck (1987). ‘Time to Build, Option Value, and Investment Decisions’. NBER Working Papers 1654, National Bureau of Economic Research, Inc. available at <http://ideas.repec.org/p/nbr/nberwo/1654.html>.
- A. Manne (1961). ‘Capacity Expansion and Probabilistic Growth’. *Econometrica* **29**(4):632–649.
- W. Margrabe (1978). ‘The Value of the Option to exchange one Asset for Another’. *Journal of Finance* **33**(1):177–186.
- J. Markish & K. Willcox (2003). ‘A value-based Approach for Commercial Aircraft Conceptual Design’. *AIAA Journal* **41**(10):2004–2012.
- M. Martin & K. Ishii (2002). ‘Design for Variety: Developing Standardized and Modularized Product Platform Architectures’. *Research in Engineering Design* **13**:213–235.
- D. Mavris & I. Fernandez (2003). ‘Integration of Real options analysis into an engine development decision support system’. In *AIAA’s 3rd Annual Aviation Technology, Integration, and Operations (ATIO) Technology*, Denver, CO. AIAA 2003-6734.
- R. McDonald & D. Siegel (1984). ‘Option pricing when the underlying asset earns a below-equilibrium rate of return: a note’. *Journal of Finance* **39**(1):261–265.
- R. McDonald & D. Siegel (1986). ‘The Value of Waiting to Invest’. *Quarterly Journal of Economics* **101**:177–186.
- C. McGill (2005). ‘Standardization Initiative for Angola’. Tech. rep., BP. Internal BP report, confidential.
- C. McGill & R. de Neufville (2005). ‘Interview notes’. BP confidential.
- M. McGrath (2001). *Product Strategy for high-technology companies: Accelerating your business to web speed*. McGraw-Hill, New York, NY.

- R. Merton (1973). 'The theory of rational option pricing'. *Bell Journal of Economics and Management Science* **4**(1):141–183.
- M. Meyer & A. Lehnerd (1997). *The power of product platforms, building value and cost leadership*. The Free Press, New York, NY.
- MIT Facilities Office (2006). 'Cogeneration Plant web page'. <http://web.mit.edu/facilities/about/utilities/cup.html>.
- V. Muffato (1999). 'Introducing a platform strategy in product development'. *International Journal of Production Economics* **60**(1):145–153.
- S. Myers & S. Majd (1990). 'Abandonment Value and Project Life'. *Advances in Futures and Options Research* **4**:1–21.
- S. C. Myers & R. A. Brealey (2000). *Principles of Corporate Finance*. Irwin Mc Graw-Hill, Boston, MA.
- NASA (2005). 'Cost Estimating Web Site'. <http://www1.jsc.nasa.gov/bu2/index.htm>.
- E. Omberg (1987). 'A note on the convergence of binomial-pricing and compound-option models'. *Journal of Finance* **42**(2):463–469.
- J. Paddock, et al. (1988). 'Option Valuation of Claims on Real Assets: The Case of Offshore Petroleum Leases'. *The Quarterly Journal of Economics* **103**(3):479–508.
- P. Papalambros & D. Wilde (2003). *Principles of Optimal Design, Second Edition*. Cambridge university Press, Cambridge CB2 2RU, U.
- D. Paxton (2001). 'Introduction to real R & D options'. *R & D Management* **31**(2):109–113.
- T. Pimmler & S. Eppinger (1994). 'Integration analysis of product decompositions'. Working paper, Sloan School of Management, MIT.
- L. Quigg (1993). 'Empirical testing of real option pricing models'. *Journal of Finance* **48**(2):621–640.
- S. Rayman & M. Zwecher (1997). 'Monte Carlo estimation of American call options on the maximum of several stocks'. *Journal of Derivatives* **5**(1).
- J. ReVelle, et al. (1998). *The QFD Handbook*. J. Willey & Sons, New York, NY.
- K. Roberts & M. Weitzman (1981). 'Funding criteria for research, development and exploration projects'. *Econometrica* **49**(5):1261–1288.
- D. Robertson & K. Ulrich (1998). 'Planning for Product Platforms'. *Sloan Management Review* .

- P. Samuelson (1965). 'Rational Theory of Warrant Pricing'. *Industrial Management Review* **6**:13–32.
- Sanderson (1995). 'Managing Product Families: The Case of the Sony Walkman'. *Research Policy* .
- R. Sargent & A. Westerberg (1964). 'Speed-up chemical engineering design'. *Transactions of Institute of Chemical Engineers* **2**:190–197.
- A. Sethi & S. Sethi (1990). 'Flexibility in Manufacturing: a Survey'. *The International Journal of Flexible Manufacturing Systems* **2**(4):289 – 328.
- D. Sharman, et al. (2002). 'Architecture optimization using real options and design structure matrices'. In *Proceedings of DETC 02 ASME 2002 International Design Engineering Technical Conferences*, 28th Design automation conference, Montreal, CA.
- Z. Siddique & D. Rosen (2001). 'On Combinatorial Design Spaces for the Configuration Design of Product Families'. *Artificial Intelligence for Engineering Design, Analysis and Manufacturing* **15**(2):91–108.
- T. Simpson (2004). 'Product Platform design and customization: status and promise'. *Artificial Intelligence for Engineering Design, analysis and Manufacturing* **18**:3–20.
- T. Simpson & B. D'Souza (2002). 'Assessing Variable levels of platform commonality within a product family using a multi-objective genetic algorithm'. *9th AIAA/ISSMO Symposium on Multidisciplinary analysis and optimization* .
- T. Simpson & B. D'Souza (2003). 'A genetic algorithm based method for product family design optimization'. *Engineering Optimization* **35**(1):1–18.
- T. Simpson, et al. (2006). *Product Platform and Product Family Design: Methods and Applications*. Springer, New York, NY.
- S. Sivaloganathan & T. Sahin (1999). 'Design Reuse: An Overview'. *Journal of Mechanical Engineering* **213**(B00899):641–654.
- J. Smith & K. McCardle (1998). 'Valuing oil properties: integrating option pricing and decision analysis approaches'. *Operations Research* **46**(2):198–217.
- J. Smith & K. McCardle (1999). 'Options in the real world: lessons learned in evaluating oil and gas investments'. *Operations Research* **47**(1):1–15.
- J. E. Smith & R. F. Nau (1995). 'Valuing Risky Projects: Option Pricing Theory and Decision Analysis'. *Management Science* **41**(5).
- G. Steuart (1974). 'Gate position requirements at metropolitan airports'. *Transportation Science* **8**(2):169–189.

- D. Steward (1981). 'The design structure system: A method for managing the design of complex systems.'. *IEEE Trans on Engrg. Management* **28**:71–74.
- E. Suh (2005). *Flexible product platforms*. Ph.D. thesis, MIT, Department of Aeronautics and Astronautics, Cambridge, MA.
- N. Suh (1990). *The Principles of Design*. Oxford University Press, New York, NY.
- K. Sullivan, et al. (2001). 'The structure and value of modularity in software design'. In *Proceedings of the 8th European software engineering conference*, pp. 99–108, Vienna, Austria.
- K. Tan & K. Vetzal (1995). 'Early Exercise Regions for Exotic Options'. *Journal of Derivatives* **3**:42–56.
- G. Tannous (1996). 'Capital Budgeting for Volume Flexible Equipment'. *Decision Sciences* **27**(2):157–184.
- D. Tavella & K. Randall (2000). *Pricing Financial Instruments*. John Wiley and Sons, New York, NY.
- J. Tilley (1993). 'Valuing American options in a path simulation model'. *Transactions of the Society of Actuaries* **45**:83–104.
- A. Triantis & J. Hodder (1990). 'Valuing Flexibility as a Complex Option'. *Journal of Finance* **49**(2).
- L. Trigeorgis (1991). 'A Log-Transformed binomial numerical analysis method for valuing complex multi-option investments'. *Journal of Financial and Quantitative Analysis* **26**(3):309–326.
- L. Trigeorgis (1993). 'The Nature of Option Interactions and the Valuation of Investments with Multiple Real Options'. *Journal of Financial and Quantitative Analysis* **28**(1).
- L. Trigeorgis (1996). *Managerial Flexibility and Strategy in Resource Allocation*. MIT Press, Cambridge, MA.
- M. Trimp, et al. (2004). 'Optimize initial spare part inventories: an analysis and improvement of an electronic decision tool'. Tech. Rep. EI2004-52, Department of Econometrics and Management Science, Erasmus Un., POB 1738, Rotterdam, The Netherlands.
- K. Ulrich & S. Eppinger (1999). *Product Design and Development*. McGraw-Hill/Irwin, New York, NY, 2 edn.
- G. Vasilash (2000). 'How Toyota does it—every day!'. *Automotive Manufacturing and Production* pp. 48–49.

- A. Vollert (2003). *A Stochastic Control Framework for Real Options in Strategic Valuation*. Birkhauser, Boston, MA.
- T. Wang (2005). *Real Options "in" Projects and Systems Design - Identification of Options and Solution for Path Dependency*. Phd thesis, Massachusetts Institute of Technology, Cambridge, MA.
- T. Wang & R. de Neufville (2005). 'Real options "in" projects'. In *9th Real Options Annual International Conference*, Paris, FR.
- A. Ward, et al. (1995). 'The Second Toyota Paradox: How Delaying Decisions Can Make Better Cars Faster'. *Long Range Planning* **28**(4):129–129.
- J. Williams (1997). 'Redevelopment of Real Assets'. *Real Estate Economics* **25**(3):387–407.
- T. Wright (1936). 'Factors affecting the costs of airplanes'. *Journal of the Aeronautical Sciences* **3**:122–128.
- A. Yassine & D. Falkenburg (1999). 'A framework for design process specifications management'. *Journal of Engineering Design* **10**(3):223–234.
- Y. A. Yu, T.L. & D. Goldberg (2003). 'A genetic algorithm for developing modular product architectures'. *Proceedings of DETC 03 ASME 2003 International Design Engineering Technical Conferences and Computers and Information in Engineering Conference* .
- T. Zhao & C. Tseng (2003). 'Valuing flexibility in infrastructure expansion'. *Journal of infrastructure systems* **9**(3):89–97.