

Implementation of New Technology in a Regulated Environment

by

Robert A. Garber

Bachelor of Science in Chemical Engineering, Purdue University (1996)

Submitted to the Department of Chemical Engineering and the Sloan School of Management in Partial Fulfillment of the Requirements for the Degrees of

**Master of Science in Chemical Engineering and
Master of Business Administration**

In Conjunction with the Leaders for Manufacturing Program at the
Massachusetts Institute of Technology
June 2004

©2004 Massachusetts Institute of Technology. All rights reserved.

Signature of Author _____

Department of Chemical Engineering
Sloan School of Management
May 2004

Certified by _____

Charles L. Cooney, Thesis Supervisor
Professor of Chemical and Biochemical Engineering

Certified by _____

Roy Welsch, Thesis Supervisor
Professor of Statistics and Management Science

Accepted by _____

Margaret Andrews, Executive Director of Masters Program
Sloan School of Management

Accepted by _____

Daniel Blankschtein, Chairman, Graduate Committee
Department of Chemical Engineering

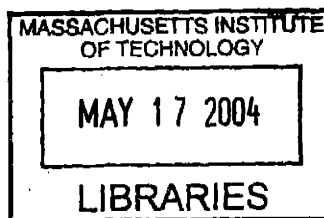

ARCHIVES

Implementation of New Technology in a Regulated Environment

By
Robert A. Garber

Submitted to the Department of Chemical Engineering and the Sloan School of Management on May 7, 2004 in partial fulfillment of the Requirements for the Degrees of Master of Science in Chemical Engineering and Master of Business Administration

Abstract

This thesis investigates potential improvements to the manufacturing process through the implementation of process analytical technologies (PAT) in the heavily regulated pharmaceutical industry. The thesis focuses on the identification, prioritization, evaluation, and implementation of Process Analytical Technologies (PAT's) to solve manufacturing issues. While full implementation of a solution is not a part of this thesis, development of an implementation plan is. In parallel to executing these four stages of the project, processes and tools for the assessment of future PAT ideas are developed. The ideas developed in this thesis were tested in an industrial setting, and several case studies are included from this work. Key results are that a rigorous business evaluation of a potential project from a financial and intangible viewpoint is necessary, that PAT can improve the efficiency of a manufacturing process both at the unit operation and entire system levels, and that the organizational structure of a pharmaceutical company and the regulatory authority will have to change in order to support the integration of PAT into the manufacturing plant. Ramifications of the new technology on the organization are presented along with recommendations for organizational change to better utilize PAT.

Thesis Supervisor: Roy Welsch
Title: Professor of Statistics and Management Science

Thesis Supervisor: Charles L. Cooney
Title: Professor of Chemical and Biochemical Engineering

Acknowledgements

I would like to thank Genzyme for sponsoring this work. In addition, I would like to thank the Leaders for Manufacturing program for its support. In particular, I would like to acknowledge:

Roy Welsch
Charles Cooney
Jeff Goldberg
Paula Soteropoulos
Mark Bamforth

The Genzyme PAT team: Peter McDonnell, Ian Davison, David O'Grady, Helene Donta, Abizer Harianawala, Ron Swearingen, Tim Belt, and Cheryl Ardizzoni

I dedicate this thesis to my wife Jennifer Garber, my mother Carol, and my brothers Phillip and Michael.

Table of Contents

Abstract.....	2
Acknowledgements.....	3
Table of Contents.....	4
Chapter 1: Introduction.....	5
1.1 Genzyme Corporation and Renagel®.....	5
1.2 Process Analytical Technology.....	6
1.3 Rationale for Process Analytical Technology.....	7
1.4 Summary of Findings.....	11
1.5 Organization of Thesis.....	11
Chapter 2: Project Description and Literature Review.....	13
2.1 Industry Problem Statement.....	13
2.2 Project Description.....	14
2.3 Challenges of Process Analytical Technology Implementation.....	16
2.4 Strategies of Process Analytical Technology Implementation.....	19
2.5 Literature Review of Industry – A Case Study.....	22
2.6 Process Analytical Technologies Available.....	23
2.7 Process Analytical Technologies – Two Widely Used Types.....	27
Chapter 3: Manufacturing Issues and PAT Solutions.....	31
3.1 Method Used.....	31
3.2 Manufacturing and Business Issues.....	34
3.3 Process Analytical Technology Options and Applications.....	36
3.4 Failure Mode and Effects Analysis of the Issue-Option Pairs.....	38
3.5 Summary.....	44
Chapter 4: Evaluation of the High Priority Projects.....	45
4.1 Purpose of the Evaluation.....	45
4.2 Technological Feasibility Evaluation.....	46
4.3 Intangible Costs and Benefits Evaluation.....	48
4.4 Financial Evaluation.....	52
4.5 Evaluation Summary.....	59
Chapter 5 – Design of PAT Solutions.....	60
Chapter 6: Implementation.....	69
6.1 Planning Process.....	69
6.2 Team Membership.....	71
Chapter 7: Organizational Ramifications of PAT.....	74
7.1 PAT and Current Organizational Structure Conflicts.....	74
7.2 Recommendations for Change in Organizations Undertaking PAT.....	77
Chapter 8: Conclusion and Next Steps.....	80
8.1 Conclusion.....	80
8.2 Next Steps: Business Process for Sustaining Momentum.....	80
Bibliography.....	84
Appendix.....	86

Chapter 1: Introduction

The Process Analytical Technology (PAT) initiative of the FDA aims to monitor raw or in-process materials in order to provide a pharmaceutical manufacturer a better understanding of their overall production process through control of process unit operations. The FDA's Center of Drug Evaluation and Research defines the PAT initiative as, "a system for designing, analyzing, and controlling manufacturing through timely measurements (i.e., during processing) of critical quality and performance attributes of raw and in-process materials and processes with the goal of ensuring final product quality." The FDA goes on to say, "It is important to note that the term *analytical* in PAT is viewed broadly to include chemical, physical, microbiological, mathematical, and risk analysis conducted in an integrated manner." By improving the understanding of the manufacturing process, it is possible that increased production efficiency levels can be achieved. Many process analytical technology options and methods are being pursued by the pharmaceutical industry, but implementation is the major challenge for most firms. Implementation has been a major challenge up until the present because of the heavy regulation in the pharmaceutical industry. Understanding the regulatory landscape will help a company make the best financial and intangible cost and benefit decisions on PAT implementations.

This chapter provides the context for Process Analytical Technology at the industry, corporate, and product levels. Therefore, Genzyme Corporation and its product Renagel® are introduced along with the Food and Drug Administration's (FDA) initiative and its industry regulations.

1.1 Genzyme Corporation and Renagel®

Genzyme Corporation is a multi-national company that discovers, develops, and markets biological and pharmaceutical products (Genzyme 2002). As per its 2002 annual report,

Genzyme General achieved revenues over \$1 billion for the first time in its history. Its largest revenue stream comes from its biological product Cerezyme®. Cerezyme® is a treatment for patients with Type I Gaucher disease.

Renagel® is a calcium-free, metal-free, non-absorbed phosphate binder for hemodialysis (process of removing metabolic waste products or toxic substances from the bloodstream by dialysis) patients and contains a polymer backbone. It is sold in three forms mostly in the United States and European markets (a few other international markets are served as well): a 403 mg capsule, a 400 mg tablet, and an 800 mg tablet.

Renagel® (under the name RenaGel LLC) began as a joint venture with Gel-Tex based in Waltham, MA. Gel-Tex was acquired in 2000 by Genzyme General. Along with Renagel®, many other non-absorbed polymer technology solid dosage products were acquired in the deal, such as WelChol. As per its 2002 annual report, 13% of Genzyme total product revenue came from Renagel®.

This thesis focused on all aspects of Renagel® manufacturing. The portion of the value chain relevant to this study includes the acceptance of raw material from the vendor through the production of the active pharmaceutical ingredient (API), formulation, compression, coating, and imprinting of the final tablets.

1.2 Process Analytical Technology

Process Analytical Technology is an initiative by the pharmaceutical industry, in partnership with the FDA, to encourage the use of analytical chemistry techniques and data analysis methods within the manufacturing process. The tools involved are for control and analysis of the raw or in-process materials. The premise is that an understanding of product attributes should also occur during production, not just at the quality control release phase. In the pharmaceutical industry, it is standard practice to perform most of the monitoring of product quality after production. The regulatory

hurdles have created an environment where the financial hurdles have been too great to follow the lead of lean manufacturers.

The use of Process Analytical Technologies can give a company a better understanding of their overall process and the physical and chemical nature of their product. Typically, PAT options include analytical chemistry used on-line, in-line, or at-line. On-line analysis is the direct measurement of a process stream, while in-line typically measures a slip stream. At-line measurement is the removal of a sample from a process stream for testing directly next to the manufacturing plant. Some of these tools are applied with statistical process control methods for monitoring quality. The level of implementation can fit along the spectrum of process information gathering through to parametric release. Parametric release means that an in-process test could replace or be used to provide a level of prediction for a post-production one. The level of implementation is a strategic decision for a company based on many different facets. These facets will be discussed in this document.

The PAT initiative has been focused on monitoring the raw or in-process materials. Tremendous value can be gained through a better understanding of the reaction chemistry, chemical content, or physical attributes of the product. Two examples of PAT are the monitoring of chemical overtones through Near InfraRed Spectroscopy, and the measurement of particle size through laser diffraction. PAT has not typically been defined as monitoring temperature, pressure, flow, or other input parameters that a company can control with conventional process feedback and/or feedforward systems. PAT applications monitor characteristics of materials, quality endpoints, and cleaning endpoints. However, PAT material measurement could lead to feedback loops for optimizing the operation of the input parameters in order to produce a higher yield or a higher quality product. Therefore, control of input parameters comes from process endpoints rather than time based ones. An example of this is drying to a certain water weight value rather than for a specific time.

1.3 Rationale for Process Analytical Technology

The purpose of the PAT initiative aims to improve the performance of the manufacturing process and to increase efficiency levels. This means that a carefully chosen, well-executed PAT project could, for example, increase yield, reduce cycle time, reduce manpower needs, or in some cases, improve operator safety and involvement. The phrase many companies inside and outside the biopharmaceutical industry use to describe this type of initiative is “Right First Time” manufacturing. There is no doubt that the pharmaceutical industry produces high quality products, but the manufacturing processes to produce them are not optimal or always well understood. The PAT initiative is an attempt to improve this efficiency and implement a culture of continuous learning.

The significance of the partnership of the Food and Drug Administration (FDA) and the pharmaceutical industry on PAT must be put into context. The regulations in the industry are a major factor in creating the situation that is present today. The current regulatory environment ensures that patient safety and product quality cannot be compromised. However, the regulatory environment also has created disincentives for companies to implement new technology. The disincentives can be length of time for approval, exposure of a previously unknown “issue” or process cliff, and auditing low risk products and processes based on frequency rather than risk level that these products or processes contain. These disincentives have led to a larger financial hurdle than otherwise would be found in other industries. The partnership was needed in order to create incentive for the industry to implement new process analytical technologies that can help improve the efficiency of manufacturing, and therefore indirectly product quality.

The PAT partnership of the FDA and pharmaceutical industry leaders was formed in the summer of 2001. It began with several of the industry’s manufacturers urging the FDA to consider forming a subcommittee of pharmaceutical manufacturers, FDA officials, private consultants, and academic experts to study and provide guidance on the idea. The purpose of this subcommittee was to provide a way for companies to implement PAT based on a “good science” basis. Up until this point, and due to the risks in compliance, many companies were either following a policy of not implementing PAT or not filing

the use of PAT. The initiative was created in order to bring about a “win-win” situation for both the FDA and the pharmaceutical manufacturers (Hussain 2002).

A significant driver for the PAT initiative was the benchmark against other industries. Table 1.1 is a summary of the pharmaceutical industry’s manufacturing performance as compared to IBM’s synthesized data from all industries (Bruttin and Dean 2003). As the data shows, there is plenty of room for improvement in the industry’s manufacturing performance. Lean manufacturing principles such as revealing and solving problems at their source, removal of non-value added activities, and just in time inventory all are potential improvements from the PAT initiative. It is also conceivable that in-process material attributes could be correlated to end of process quality testing. This may result in the long-term ability to perform some parametric release, or at least safety stock reduction, like in the automotive or semiconductor industries.

Table 1.1 – Unmet Performance Expectations

Category	Performance Indicator	Typical for Pharma	Best (All Industries)
Facilities	Asset Utilization	5-10%	85-90%
Material	Process First Pass Yield	80-90%	99%+
Time	Value-added Ratio	5%	50%
People	Labor Productivity (direct to indirect)	2:3	0.5:1

Asset Utilization = % of available manufacturing hours used to make product

Process First Pass Yield = % of product that passes quality control testing on the first attempt

Value-added ratio = % of total work done in manufacturing that is value-added to the product (an example of non-value added work is movement of work in process from one step to another)

Labor productivity = the ratio of direct labor to indirect labor

Finally, one last rationale for the ability to better understand one’s own pharmaceutical manufacturing process through PAT is the FDA’s discussion to move to risk-based auditing. In many forums, representatives of the FDA have stated that they are facing resource issues with their auditing teams, and rather than spend more money, would aim to be more efficient. A risk based auditing system would mean that companies’ factories that are deemed high risk are more likely to face higher scrutiny levels than factories

deemed low risk. This risk determination will be partly determined by how much control and understanding a company has of its manufacturing process. PAT tools designed to measure raw or in-process materials are set up to provide this deep understanding necessary to lower the potential risk. Therefore, it is conceivable that the FDA may audit a factory less often and with greater focus on key process points.

In fact, on September 3, 2003, the FDA and CDER issued a press release and multiple guidances with an overall theme titled, "A Risk-Based Approach to Pharmaceutical Current Good Manufacturing Practices (cGMP) for the 21st Century." One of the guidances released in draft status was called, "Guidance for Industry: PAT – A Framework for Innovative Pharmaceutical Manufacturing and Quality Assurance." This draft guidance described the future of pharmaceutical manufacturing under PAT, and presented ideas on how this may look. While they are not mandating the implementation of PAT's, they are trying to create a regulatory environment that fosters the innovation. This draft guidance fits into the overall, long-term strategy of the FDA to audit factories based on the risk they pose in terms of product indication, product type, product quality, and understanding of the process. Hence, PAT increases knowledge of the process, creating a lower risk environment.

The organizational structure of companies and regulators will come into the forefront as well. Most companies have structured themselves based on the current regulatory environment. This organization means that pharmaceutical manufacturing plants file strict procedures on how they produce, and must comply with the filed process. Continuous improvement of an approved process is not normally done. Manufacturing processes utilizing previously unused equipment technology are not normally developed. Getting started with the implementation of process analytical technology is a perceived risk to the current culture of the pharmaceutical manufacturing plants and the regulatory authorities. As a sign of the perceived risks of embarking on PAT, one interviewed executive stated, "the first time the FDA holds up a New Drug Approval because of a PAT will be the last time anyone tries an implementation" (anonymous industry executive 2003). In addition to the need for change within companies, the culture of the

FDA, EMEA (European Agency for the Evaluation of Medicinal Products) and other agencies will need to change to prove itself as serious to companies before they embark on massive PAT implementations. Therefore, organizations in the industry and in the regulatory bodies will have to change to accommodate PAT.

1.4 Summary of Findings

- PAT is intended to solve a wide range of pharmaceutical manufacturing problems, if the strategy for implementation in the plant is well designed. The improvements come in the form of improved yield and more predictable unit processes leading to more consistent output.
- Companies should perform a proper prioritization process, such as Failure Mode and Effects Analysis, and business evaluation when deciding which projects to undertake. These steps are necessary when embarking on a PAT program to ensure the plans fit into the needs of the company.
- There are many organizational ramifications of PAT both within firms and within regulatory agencies. The cultural changes are large and need to be recognized during implementation planning for a PAT installation.

1.5 Organization of Thesis

The layout of the thesis is as follows:

Chapter 2 introduces the problem statement, the description of the project, and reviews relevant literature on implementations of PAT, technologies associated with PAT, and describes in detail two widely use technologies.

Chapter 3 discusses the business process used during the project, the use of Failure Mode and Effects Analysis to identify and prioritize manufacturing issues and potential

solutions to those issues, and some example problems and solutions a pharmaceutical manufacturing plant might face.

Chapter 4 presents a business evaluation process and tool to ensure that even the highest priority projects have a positive tangible or intangible value to a firm.

Chapter 5 is a study of a pharmaceutical manufacturing process flow design with PAT solutions.

Chapter 6 gives a high level glimpse into implementing a PAT into the regulated environment of pharmaceutical manufacturing. The chapter includes information on the planning process and proposed members of the implementation team.

Chapter 7 gives the organizational ramifications of Process Analytical Technology and provides some recommendations that firms should consider when embarking on a PAT implementation.

The final chapter, Chapter 8, presents conclusions and next steps of the process. The next steps section includes a business process for sustaining momentum after a company has analyzed its initial PAT project.

Chapter 2: Project Description and Literature Review

This chapter introduces the problem statement, the description of the project, reviews relevant literature on implementations of PAT, technologies associated with PAT, and describes in detail a few widely used technologies. In addition, current challenges to implementation are discussed along with strategies for maneuvering through them.

2.1 Industry Problem Statement

The pharmaceutical industry has historically had lower asset utilization, first pass yields, value added ratio, and labor productivity than other industries because the regulated environment has led to a situation where the financial risks of change have stopped many efficiency improvements in the manufacturing areas. Therefore, in general the industry suffers from:

- Lacking a full understanding of the manufacturing process (i.e. how does Active Pharmaceutical Ingredient (API) manufacture impact finishing)
- Long production and quality assurance cycle time, which postpones the identification of issues and puts subsequent batches at risk of rejection
- Support costs that are increasing at a faster rate than production volumes, and therefore not leveraging the economies of scale
- Needing to optimize production to reduce costs due to many pressures on the P&L such as higher research and development costs and price pressure
- Manufacturing inefficiencies that are transferred from one generation of products to the next generation

A better understanding of a firm's manufacturing process, through the use of Process Analytical Technology (PAT), could help alleviate risks and improve the efficiency of production. Process Analytical Technology is a joint initiative between the Food and Drug Administration and the pharmaceutical industry to use tools in the production

process to better understand raw or in-process material attributes. It is typically defined as monitoring output variables. Its use should enable firms to see an improved financial situation, such as, more capital for research and development or to deal with the pressures of lower prices.

Finally, the PAT initiative comes out of the FDA's Center for Drug Evaluation and Research (CDER) and in its early stages is most applicable to pharmaceuticals.

2.2 Project Description

The goal of the thesis is to investigate potential improvement to the manufacturing process through the implementation of new process analytical technologies with a particular focus on the heavily regulated pharmaceutical industry. The case study for the tools and processes to be developed is Genzyme's Renagel® manufacturing. The project will focus on the identification, prioritization, evaluation, and implementation of PATs to solve critical manufacturing issues. While full implementation of a PAT solution will not be a part of this thesis, development of an implementation plan will be. In parallel to executing these four stages of the project for the current state in Renagel® manufacturing, the project will focus on developing a process and tools for the assessment of future PAT ideas. Process and tool development are the central findings of this thesis.

The scope of this thesis was to develop the processes to study the issues and potential PAT solutions at internal Genzyme Renagel® manufacturing and R&D sites in the United States and European Union. To accomplish this goal, a PAT team was formed that included members from the sites and areas listed and was cross discipline in nature. Representatives from the Manufacturing Technical Support, Technology Development, Program Management, Analytical Chemistry, Regulatory, Quality, and Production areas were included. The author was to lead this cross-site, cross-functional team through the execution of identifying, prioritizing, evaluating, and planning the implementation of PAT while developing the business process at the same time. This method was an

excellent approach because while the project was being executed, the business process could be mapped and documented.

There were several key deliverables expected from the PAT project team. These are listed and described below.

- Develop a process to identify key manufacturing issues and potential PAT solutions: There needs to be a specific impact of the issue on the business. The identification process will be a brainstorming exercise and fairly comprehensive.
- Prioritize the issue – solution pairs: In order to keep team resources focused on the right projects, a priority ranking process must be developed and utilized.
- Evaluate the highest ranked issue – solution pairs: This evaluation needs to encompass financial costs and benefits, but also has to include intangible ones. In addition, an assurance of technical feasibility has to be involved. An evaluation tool and process that can be applied to other new technologies must be developed and utilized.
- Plan the implementation of the highest ranked and positive total value issue – solution pairs: In order to provide the manufacturing sites traction on the new projects, full implementation plans are to be completed. A new process for providing these plans will be developed in order to be utilized for future new process analytical technology implementations.
- Map the overall business process for the above four steps for future PAT implementations. Focus on sustaining the process the team can use to stay connected with each other and on equipment technology developments.

It was also important to benchmark the pharmaceutical industry on Process Analytical Technology and the state of the regulatory environment. Benchmarking was necessary because of the relative ease that other industries have been able to implement new technologies such as PAT versus the rigidity of the pharmaceutical industry's regulated environment. The chemical manufacturing industry has used these techniques for 20 or more years. The present time was the right time for completing this benchmarking study

as the pharmaceutical industry was open to collaboration. In fact, many conferences and papers have appeared recently as firms share information on their accomplishments. The environment seemed collaborative as everyone strived to improve their efficiency.

The following three sections are descriptions of the challenges to implementation, a case study, and a short description of some PAT's available.

2.3 Challenges of Process Analytical Technology Implementation

Implementation of a fundamental change in a regulated environment is challenging. This fact is especially true when patients' safety is of the highest concern. Many hurdles can stop a project. The chosen level of use, the lifecycle stage of the product, and the amount of intrusion in the process by the measurement can help define the complexity of a PAT project. Many different parts of the company's organization can be affected depending upon these three scope items.

To illustrate how the organization could be affected, a geometric x, y, z plot can be drawn as shown in Figure 1. On the x-axis, the product status in the life cycle can be plotted in phase 2, phase 3 or approved for sale. Phase 1 clinical trials are small, early stage tests that help determine safety of the product in healthy volunteers. Phase 2 clinical trials are the first set of trials in sick patients and are usually called safety and efficacy studies. They are also sized small; about 150 patients could be a typical number. Dosage and initial effectiveness are studied in this phase. Phase 3 clinical trials are the most important and final battery of tests before filing the New Drug Application. It can consist of anywhere from 100 to 5000 patients, depending on the indication. Implementation of a PAT in a phase 2 product is relatively easy as the manufacturing process is not filed in great detail with regulatory bodies. Approved products are clearly in the opposite situation, where changes must be documented with the FDA, the EMEA, or other countries' agencies. Potential products in phase 1 clinical trials are ignored for this analysis because it is assumed that manufacturing at this scale is less routine.

On the y-axis, the amount of intrusion to the process can be plotted as low, medium, or high. A low amount of intrusion would mean that the measurement technique is not making contact with product and not interfering with process streams and flows. On the z-axis, the intended level of use can be plotted as information only, control, or parametric release. Parametric release means that an in-process test could replace or be used to provide a glimpse into a post-production one. Therefore, an in-process test would be a strong predictor for a high quality end product. Control implies that a feedforward or feedback process control based on a measurement would be implemented. As a project moves away from the origin, the level of complexity increases. To illustrate this complexity, two hypothetical examples are discussed.

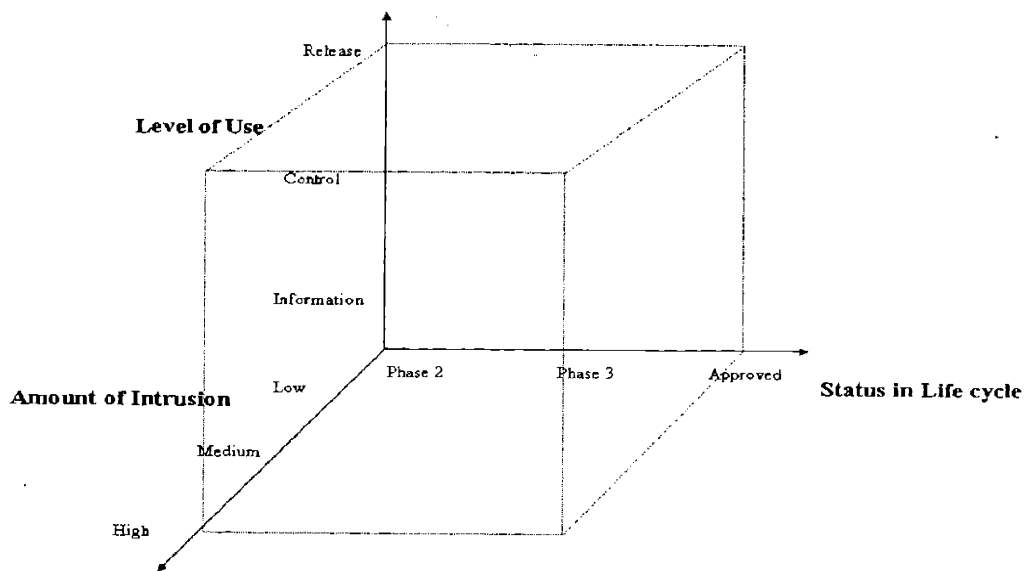

Figure 2.1 – Complexity Level Plot

Let's assume a company has a product that is approved for marketing and sales. In addition, there is a problem during manufacturing that a post-production assay is difficult to run and has many "false negatives", which leads to quite a bit of scrap material. The process development team determines that a PAT solution could be used, but involves a medium amount of intrusion into the process. The PAT solution could be used in lieu of the assay, so parametric release of that particular assay is the ultimate intention.

Based on this theoretical example, it is clear that this change is a very complex one. The regulatory department would likely have to file a post-approval change to all regulatory bodies that have approved the product. Multiple filings could mean an approval process of 0 to 18 months depending on the country and type of change. The quality department would require proof that the replacement of an assay with an in-process measurement is possible. This proof means a rigorous side-by-side experiment to ensure it truly is a replacement. In addition, there would have to be experimentation and validation that the intrusion to the process has not changed the product based on the installation of the new equipment. Both departments would require validation of the system. Potentially, there may need to be compliance with the FDA's 21 CFR Part 11 rules for electronic data handling, which would depend on whether or not the equipment stores the info or the operator writes it down. If there is electronic data handling required, then the information technology department would need to ensure that they meet the requirement. In addition, the data must be handled so that it meets the requirement of the operations team to allow for control of input parameters. Finally, the operations team must understand what the PAT equipment does, how to analyze the data generated, maintenance and calibration that must be done, and proper operation. All of this must be done with an understanding and strict control of inventory so that only approved procedures are used for released products. Clearly, the complexity of this type of change is high.

A second theoretical example could be that a company has a potential product in phase 2 clinical trials, and wants to better understand moisture content during a drying process. This understanding may be necessary in order to scale up a process properly at minimum cost or to set safety stock levels properly. An information only level of use is intended, and the technique chosen to measure moisture is non-intrusive to the process. The level of complexity decreases tremendously as compared to the first example. The regulatory and quality hurdles are small, the data handling system may not need to be validated since the information will not be used for control, and the operations team can be trained on the equipment as part of a normal production ramp as the product moves to scale up. In addition, approval for use would come as part of the New Drug Application.

Figure 2.2 shows a plot of these two theoretical projects and their relative distance from the origin.

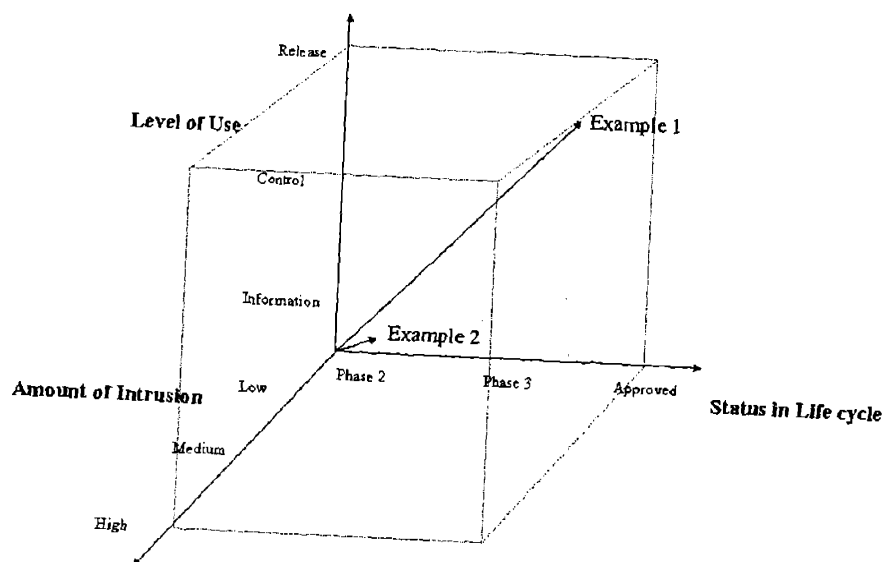

Figure 2.2 – Complexity Plot with Examples Shown

These two examples illustrate two potential levels of implementation and thus two different levels of complexity. As potential PAT projects are identified, the three factors of level of use, product status in the life cycle, and amount of intrusion into the process must be carefully understood. Understanding these factors can ensure that a good plan is built for implementation. These strategies are discussed in the next section.

2.4 Strategies of Process Analytical Technology Implementation

Due to the complexity of making a fundamental change in a heavily regulated industry, it is important to outline a strategy for development and implementation of a new process analytical technology. One such strategy, as proposed by the author, is to:

- 1) Perform background research including benchmarking, one on one meetings with key team members, and reading through the literature
- 2) Form a team that includes experts from the manufacturing, quality, regulatory, information technology, business, and process development areas
- 3) Identify manufacturing issues that may be able to utilize the PAT
- 4) Identify potential process analytical technology solutions to those problems in order to develop the combination into potential projects
- 5) As a team, determine a process in which the brainstormed list of ideas can be prioritized
- 6) Prioritize the brainstormed list to ensure the team works on the most important projects
- 7) Review the prioritized list to ensure it makes sense subjectively as well as objectively within the broader context of the project's goals
- 8) Perform feasibility studies on the high priority projects (may be necessary to iterate with #6)
- 9) Draft a rough scope plan
- 10) Inform and engage the regulatory authorities on the change (if necessary)
- 11) Gather data on the tangible and intangible costs and benefits
- 12) Perform an intangible evaluation of the chosen projects
- 13) Perform a financial evaluation of the chosen projects
- 14) Iterate as necessary between items 12 and 13
- 15) Assuming there is positive value to the company in doing the project, begin working to secure budget and finalizing the scope and schedule plans
- 16) Begin the implementation
- 17) Team to meet regularly and check the prioritized list and document changes to the list

This process is mapped out in detail in the Appendix Figure A. Chapter 3 discusses how the team should make the decisions described in this process. Chapter 4 discusses how best to evaluate the top projects.

A similar process was proposed by Dziki and Novak from Abbott Laboratories (Dziki and Novak 2003). Their process was a ten step one and did not include any prioritization or business evaluation steps. Their process was as follows:

- 1) Formation of an Internal “PAT Team”
- 2) PAT Team Mission Statement
- 3) Select an Application – simple and at-line or off-line
- 4) Select the Appropriate Analytical Technology for the Application
- 5) Perform a Lab Scale Feasibility or Proof of Concept Study
- 6) Separate FDA’s Vision of PAT into more Manageable Concepts of PaT (development of model) and PcT (integrate the model into controlling the process)
- 7) Contact and Consult Instrumentation Vendors
- 8) Select and Install the Recommended Instrumentation and Sensor
- 9) Maintain the PAT Calibration Model by the “PAT Champion” or Designee
- 10) Train and Instruct

Smaller firms, such as Genzyme, are more likely to need to follow the first process because of its focus on a fast, positive impact to the business. Larger firms can spread the costs of PAT experimentation across a wider array of products. For this reason, Genzyme followed the first process. Understanding the differences in the two strategies is necessary to explain the diverging paths followed.

A major difference in the two processes is that Dziki and Novak propose that an application for a PAT should start simple and be at-line or off-line, while the first process makes no such stipulation. While it is important to begin testing feasibility of a PAT off-line, if the issue has no relevant business impact, then the technology will not be used. It is best to ensure that the application or manufacturing issue is one that will have a positive impact on the business. This is probably much more important than collecting data in an off-line, simple mode.

Another important difference in the two processes is the need for a business justification in the first one. In my opinion, this is important for a smaller firm. Quickly, the firm will expect that the financial outlays will begin to payback positively. The premise is that a team may develop a lengthy list of PAT applications, but they must be evaluated against financial and intangible costs and benefits criteria. Once evaluated, the team should be able to justify moving forward with a project or stopping the project. I believe that a smaller pharmaceutical firm would be more interested in spending money on research and development on future products rather than improving the efficiency of its manufacturing capability. In addition, a smaller firm risks a higher percentage of their revenue if they shut down a product stream because of a bad implementation. By showing positive value even on initial projects, the PAT projects can be justified. The specifics behind this evaluation will be discussed in Chapter 4.

2.5 Literature Review of Industry – A Case Study

This section will focus on a successful case study of Process Analytical Technology implementation by Pfizer Inc (O'Neill 2003). Pfizer uses Near InfraRed spectroscopy to monitor the drying process for an active pharmaceutical ingredient (API). Pfizer's current process is to dry the API from ~20-30% to 4.8% water wet. Product can only be released once two consecutive samples are <4.8%. The first sample is not taken until 24 hours have elapsed. A second sample must be taken at least 2 hours later.

Pfizer implemented an in-situ NIR measurement in each stage of a three stage drying process. The system provides real time information, and is fully qualified and validated. An NIR region was chosen in order to capture the O-H combination of water. NIR is a non-destructive, non-intrusive technique. Baseline differences were eliminated, over one hundred samples were used as a calibration, and a five latent factor partial least squares statistical model was applied in order to monitor the O-H combination band.

Pfizer used an ABB Bomem FT-NIR analyzer, with three multiplexed probes. Fiber optic cables were used for signal delivery. The equipment cost plus fiber optics was

approximately €120,000 (~\$140,000), while the total cost of the project was approximately €260,000 (~\$310,000). Unfortunately, there has not been any return on investment report published.

Through the trending of the drying process some potential process improvements were found. The product is normally within dryness specification at 17 hours, leading to a potential cycle time reduction of ~10 hours. The product is normally dry after two stages, leading to the potential elimination of one dryer. Finally, operators will come in contact less with the product because manual sampling would not be necessary. The bottom line is that there exists the potential for cycle time reduction, a higher level of operator safety, and capital avoidance.

Pfizer reports that there were many key factors to achieving a successful implementation of this PAT project. These factors were:

- Early in the project, the team clearly defined the goal and structured a plan
- Spent time in the laboratory and on pilot plants choosing the right analytical technology
- Ensured that the project team included all major disciplines
- Management visibly supported the project
- Constant communication with and seeking of advice from the operators was vital to getting agreement from the end user
- Vendor was contractually committed to a successful implementation and validation

2.6 Process Analytical Technologies Available

The number of equipment and software vendors selling Process Analytical Technologies has increased greatly as the Food and Drug Administration has signaled more acceptance of the use of PAT's for improvement of manufacturing efficiency and continuous improvement of production processes. In addition to analytical chemistry techniques,

many other methods work in tandem to produce the desired outcome of a more efficient manufacturing process. These methods are multivariate statistical analysis, process endpoint monitoring, and knowledge management tools.

Multivariate statistical analysis tools, many times referred to as “chemometrics” in the chemical and pharmaceutical industry, are necessary because of the complex, many factored systems that pharmaceutical production contain. Because they do not allow for a full understanding of process capability and do not adequately reflect the interactions that occur in these complex processes, univariate process control charts can lead to higher rejection rates.

Process endpoint monitoring is a shift from the currently used pharmaceutical manufacturing method of time-based endpoint monitoring. Rather than setting a specific time for a drying process to be complete, a percentage water weight could be tracked using a PAT instead. Process endpoint monitoring measures the material attribute and gives the operations team a better understanding of the process capability. This method also should lead to a more consistent product quality and increased process efficiency.

Knowledge management tools are the application of continuous improvement processes to proactively drive up yield, output, and quality and learn from past mistakes. They can also mean data collection through information technology tools. These methods should be used in conjunction with the equipment technologies. The equipment technologies are driving the capability to do these methods to new limits. Some of the equipment technologies are described in Table 2.1.

Table 2.1 – Available Equipment Technologies

Technology	Operation Principle	Pros	Cons	Potential Implementation
Near InfraRed	Measures unique overtones / combination bands to produce spectra. Spectrophotometers have a filter, grating, or interferometer that measures the wavelength range of 780-2500 nm. Intensity of the reflected or transmitted light is collected and measured. (Spectroscopy Now 2003)	Data easy to quantify. Many companies are using and selling this technology	Particle Size information is relative, not absolute	Monitor changes in API chemical make-up, moisture content, particle size, raw material characterization, amount of excipients
Near InfraRed Chemical Imaging	Uses NIR technology to collect a hypercube of data - measures intensity over a range of wavelengths over the surface or the area of a material (tablet surface) (Spectral Dimensions 2003)	Spatial distribution info can be valuable	Only at-line use available	Uniform distribution of excipients / water & Differentiation of tablets that are visually similar
Ultrasonic Spectroscopy	Uses acoustical waves to create intermolecular attraction/repulsion. Attenuation and velocity of the emitted and collected waves are measured. (Ultrasonic Scientific 2003)	Can be used on many gas, liquid, or solid - even opaque materials. Not just surface info generated.	Only at-line use available	Gel concentration, cross-link density, state of hydration, rates of hydration, completion of cross-linking, non-destructive material testing for cracks
Focused Beam Reflectance Measurement	Measures number, size, and shape of particles. Laser is focused just outside the probe window and rotated around circumference. Duration of time light is backscattered is measured and multiplied by speed of the laser movement. (Barrett 2003)	Gives shape info of particles (does not assume spherical)	Cannot be used for materials that do not backscatter	Particle size and shape on output of crystallizers or filtration
Laser Light	Measures grain size and	On-line	No shape	Particle Size on

Scattering	number of particles. A laser beam is directed through a carrier fluid, and the angle of scatter and the intensity is measured. The angle is inversely proportional to the particle size, and the intensity corresponds to the number. (Malvern Instruments 2003)	technology available	info is provided	output of dryer
Raman Spectroscopy	Spectra are produced by using monochromatic radiation to cause inelastic scattering. Energy is exchanged between a photon and molecule such that the scattered photon ends up with a higher or lower energy than the initial one. (Spectroscopy Now 2003)	On-line technology available	Difficult to quantify. Laser safety. Surface Info Only.	Measure extent of reaction in CSTR's, look for polymorphisms
Raman Imaging	Uses Raman technology to collect a hypercube of data - measures intensity over a range of wavelengths over the surface or the area of a material (tablet surface) (Spectroscopy Now 2003)	Spatial distribution info can be valuable	Only at-line use available	Understand polymorphs & Uniform distribution of excipients / water
Optical Probes	A high-speed camera with pattern recognition. (Cognex 2003)	Has been widely used in other industries	Difficult to quantify	View discrete objects (from particles to tablets to packaging) real time and match them against a "trained" pattern
Thermogravimetric Analysis (TGA)	Changes in weight are measured as the material is heated in air / controlled atmosphere. Thermogravimetric curves (thermograms) provide information regarding polymerization reactions, the efficiencies of stabilizers and activators, the thermal	Easy to quantify	Slow turnaround time / At-line only	Can be used for % Moisture, Decomposition, Oxidative Induction Time, % Ash, % Composition

	stability of final materials, and direct analysis. (PETA Solutions 2003)			
Mid-InfraRed	Measures the wavelength range of 5000 - 900 cm ⁻¹ . Intensity of the reflected or transmitted light is collected and measured. (REMSPEC 2003)	Effective for low concentrations on metal surfaces. On-line available.	Surface info only, broad bands make quantifying difficult	Monitor and control reactions. Cleaning validation.
Nuclear Magnetic Resonance	NMR Spectroscopy can collect the following information: the number of NMR signals, the position of each signal relative to a reference signal, the relative area under each signal, the spin coupling or spin spin splitting pattern of each signal. (Spectroscopy Now 2003)	Able to measure amount of nuclei in a specific molecular environment	Sample presentation is difficult	Measure solids content and extent of reaction

2.7 Process Analytical Technologies – Two Widely Used Types

Two process analytical technologies are worth exploring deeper, and therefore are discussed here. They are near-infrared spectroscopy and Raman spectroscopy. Reasons for a deeper discussion on these two technologies are that a high amount of literature has been published lately, many conferences have been organized on their implementation, and the amount of equipment vendors has grown rapidly.

Near-InfraRed Spectroscopy

Near-infrared (NIR) spectroscopy is a technique that is getting a lot of attention for PAT applications. NIR Spectroscopy measures the unique overtones and combination bands that each chemical substance generates in the NIR band of 780-2500 nm. NIR Spectrophotometers are normally made up of a filter, grating, or interferometer system. There must also be collection and measurement of the intensity of the reflected or

transmitted light from the sample. The spectral data that is collected and measured will then be manipulated mathematically to trend the information. The mathematical treatment is normally a principal component analysis (PCA) or principal component regression (PCR) / partial least squares (PLS).

The definitions of PCA, PCR, and PLS are (Broad 2002), “PCA. A mathematical manipulation of a data matrix where it is possible to describe the variation in the data with a smaller number of orthogonal components....PCR and PLS are inverse calibration methods where it is possible to calibrate for the desired component without selecting variables and accounting for sources of variation within the data. The methods are factor based and use different methods to select the factors.”

NIR spectroscopy’s detection and analysis are fast. There is very little, if any, sample preparation prior to measurement. There is a high dynamic concentration range. Most importantly for the application to PAT, the data is easily quantifiable through chemometric models. This last point makes the method useful for measuring chemical and physical properties of the desired substance and developing statistical process control methods to monitor performance.

The potential to predict how well a process will perform is called “conformity”. Assuming an accurate training data set, if a measured material’s spectral signature falls within predetermined limits, then the process owners can be confident that the material will conform to its desired end-state. This fact may even lead to parametric release of pharmaceuticals due to its in-process measured characteristics. Through the use of Near-InfraRed spectroscopy, a firm may gain a fundamental insight into a product attribute and be able to design in quality, or worst case monitor and control the quality. This improvement could lead to the elimination of some cumbersome end of line testing.

NIR has been used to monitor particle size changes, moisture content, completeness of blending, and reactions (Winsky and Hammond 2001). Many firms have entered the market for selling NIR spectrometers such as Bruker, ThermoNicolet, Analytical Spectra

Devices, and Foss. Many more firms are entering this market, making it more competitive. The most successful firms will be the ones who can quickly diagnose a useful implementation into a plant, have a high level of support for first time users in manufacturing, and produce robust, repeatable, and reliable spectra. A typical cost for an in-situ system including multiplexing (ability to branch off probes and utilize one analyzer) capability is approximately \$150,000.

Raman Spectroscopy

Raman spectroscopy is an analytical technique whereby spectra are produced by using monochromatic radiation to cause inelastic scattering on the molecules in question (Laserna 2001). Energy is exchanged between a photon and molecule such that the scattered photon ends up with a higher or lower energy than the initial one. The difference in energy gives information on the energy levels of that molecule.

The method works with a laser as its light source, to lessen stray light scattering effects and is delivered to the sample by fiber optics. Computers are used to perform analyses such as Fast Fourier Transforms. Due to the physical nature of Raman, it is normally used in a reflectance mode and provides information on the surface of the sample. For example, tablet information gained would be surface only.

Unfortunately, the random nature of the energy differences make the method difficult to quantify, thereby making it difficult to use for process control. Concentrations of desired molecules can be inconsistent. However, applications for monitoring the reactions of thermosets have been studied (Cooper 1999). With robust, reliable, and repeatable sampling techniques, SPC methods can be used to monitor a process with Raman Spectroscopy.

Safety concerns about using a laser in a plant have been mostly eliminated with the use of interlock systems that will shut off the laser if exposed to the surrounding environment. The technique itself is non-destructive and can be installed in a manufacturing plant

through a sapphire window. In fact, the FDA calls this type of implementation a “non-invasive” installation, and the regulatory implications are quite low.

There have been many proposed uses for Raman spectroscopy such as understanding and identifying polymorphs and monitoring the uniform distribution of formulation excipients and water in a blend. Other applications have included the monitoring of the extent of a reaction. A typical cost for an in-situ system including multiplexing capability is approximately \$200,000.

Chapter 3: Manufacturing Issues and PAT Solutions

This chapter focuses on the processes used to determine which manufacturing issues are present, what potential PAT solutions are available, and a tool for prioritizing these potential projects. This tool is called a Failure Mode and Effects Analysis and is used in this application to determine business risk. The entire process is discussed here, and then examples are given at each stage of that process. Specific examples are used throughout to illustrate the entire procedure.

3.1 Method Used

The business process for screening, prioritization, evaluation, and implementation of PAT projects at Genzyme is the synthesis of many team based and individually executed steps. The first step is to set up a team that is cross functional in nature and has a clear leader. The cross functional representation should provide detailed information on the current manufacturing process issues, on the potential PAT applications available in the industry, on the regulatory environment, on the quality release criteria, and on the economic cost drivers for a project.

In Genzyme's case, this cross functional team was set up, with the author as the team leader, and started by brainstorming a list of manufacturing issues across the Active Pharmaceutical Ingredient (API) and Finishing parts of the value chain for its product Renagel®. Once these issues and impacts to the business were documented, the team moved to investigating the potential PAT options available. The next logical step was to match the available technologies to the manufacturing issues. No evaluation or prioritization took place up to this point. It was important to document every potential project and let an agreed upon prioritization process "pick" the right projects in order to not let personal bias eliminate a potential high priority project. The process also allowed for as objective as possible discussion to take place on the proposed projects.

Next, the team had to develop a prioritization process and did so altogether. This process was followed so that full buy-in would be achieved when the developed outcome became clear. In addition to process development, the prioritization was executed as a team. Prioritization was not done with surveys, off-line ranking, etc. It was done during team meetings and was scrutinized by the group. The process was executed this way to ensure that the results were believable and “calibrated” the same. The team therefore could support the results as a cohesive unit.

The team decided upon a prioritization process called the Failure Mode and Effects Analysis (FMEA). This analysis method allows projects to be prioritized based on a Risk Priority Number (RPN). The RPN is typically calculated by multiplying the scores of three measures; however our team added a fourth category. These categories are:

- Severity of the problem - tangible/intangible costs to the business
- Frequency of the problem appearing
- Ability to detect the problem with the chosen PAT solution
- Ease of implementation – added category

Many examples of FMEA have been documented. One example examined the semiconductor equipment industry and a guide for continuous improvement in new product development (Villacourt 1992). This example fit with the one attempted by Genzyme and both were used as a baseline process model. However, the Genzyme team believed it to be important to capture the regulation and implementation complexity as well. In a heavily regulated industry such as pharmaceuticals, it can be important to build momentum for a long-term, strategic initiative like PAT. Therefore, adding a category for Ease of Implementation encompasses issues such as:

- Probability of approval by regulatory authorities
- Probability of approval by senior management
- Cost of capital not restrictive for the timeframe discussed
- Complexity in sampling the process point in question

- Support level of the entire organization (political factors)

These are only some of the items included in ease of implementation, but they represent items that do not fall into the severity, frequency, or detection categories. However, they are important in terms of a very complicated continuous improvement project.

The four FMEA categories were ranked on a 1 to 3 scale. The chart below details the criteria for scoring in each category. Any item scoring a “3” would have a higher priority than an item with a score of “1”. Table 3.1 details the scoring criteria.

Table 3.1 – FMEA Scoring Matrix

	1	2	3	Comments
Severity	Low Cost Issue	Moderate Cost Issue	High Cost Issue	
Frequency	< 10%	10-50%	>50%	Both batch to batch and/or within a batch
Ease of Detection	Hard to detect	Moderately easy to detect	Easy to detect	Each PAT option gets its own score
Ease of Implementation	Large, difficult hurdles	Moderate amount of hurdles	Easy and/or few hurdles	Each PAT option gets its own score

By developing the scoring matrix, the team attempted to take as much subjectivity out of the process as possible. While it is impossible to completely remove subjective opinions, it was attempted so that future PAT projects could be evaluated with the same baseline. It was determined that the ease of implementation category needed guidelines on how to score it. The team developed a guideline that assisted in scoring ease of implementation. These guidelines were not a rigid rule but were used in a consultative manner. Table 3.2 details the ease of implementation scoring guide.

Table 3.2 – Ease of Implementation Scoring Guide - Examples Matrix

	Regulatory	PAT Capital Cost	Sampling	Duration of experiments needed to bring into use
Hard	Major - Prior Approval	>\$300K	Need outside help to design	>6 months
Moderate	Moderate - Supplement - Changes Being Effected	\$100K-\$200K	Design in-house, and has minimal special requirements	2 - 6 months
Easy	Minor (Annual Report)	<\$100K	No special requirements	<2 months

The risk priority number (RPN) was calculated by:

$$\text{RPN} = \text{Severity} \times \text{Frequency} \times \text{Detection} \times \text{Ease of Implementation}$$

A perfect high score was 81 and perfect low score was 1. Again, the team completed the scoring through a series of group meetings to ensure full buy-in for the highest rated projects. However, the highest scoring projects were scrutinized to ensure that they made sense. The team did not blindly accept the top project as the absolute highest priority. The subjective discussion was needed because the team wanted to ensure that reason played a factor. It was also done to gain trust in the new process.

The top projects for each site progressed on to the next phases of the overall process for business evaluation and technological feasibility study, as discussed in Chapter 4. Some examples of projects discussed are explained in Section 3.2.

3.2 Manufacturing and Business Issues

The manufacturing issues identified were the portion of the process encompassing active pharmaceutical ingredient (API) manufacturing through imprinting of the identifier on the coated tablet. Issues were included that had any potential for a PAT solution. A PAT

could be a point solution or a process solution. These solutions are different in that a point solution would be implemented only as a unit operation installation, and a process solution could affect a different downstream operation than the process step of the installation. The scope included issues that were relevant to the understanding of raw or in-process materials. If there was any doubt as to relevance of PAT to the issue, the item was kept on the list. In addition, the impact of the issue was documented at this stage. For some issues the impacts were quantifiable, but for others they were not. The brainstormed list encompassed 22 items. A few examples from this list are included here.

The first example is in the production of the API. Typically a process includes a drying step that is set with a time based endpoint. The purpose of the step is to get the product below a certain water weight by drying for a given amount of time. If a process based endpoint were determined and used, rather than a time based one, then cycle time in this unit operation could be reduced. Another benefit would be a consistent end product from the output of the dryer.

The second example is in the blending of the API with a lubricant and glidant during the finishing stages of the tablet manufacturing. A lubricant is used to prevent the tablets from sticking to the compression punches downstream. A glidant is used to improve the flow properties of the powder as it flows into the dies in the compression stage. Improper blending of these materials can lead to problems in the compression stage at many firms. Many tableted products have quality controls on the appearance or formation of the tablets which can be greatly affected by the performance of the compression process. Therefore, the premise is that an analytical technology that provides real time monitoring of the blending stage could ensure that a material quality endpoint was reached rather than a time-based one. The monitoring would lead to the prevention of appearance or formation defects.

The third example is the validation of a cleaning process in the formulation stage of the manufacturing process. After many batches, it is necessary for most plants to put the production line through a cleaning process in order to prevent the growth of bacteria or

build up of material. A swab test or validation of vessel cleanliness is normally necessary to ensure the detergent and old product does not end up in subsequent products or batches. Typically, the length of time between cleans is trial and error. The swab test can be relatively quick to execute, but labor intensive and highly variable (N. Mehta 2002). The microbial testing can take as long as two weeks. The testing requires time and off-line equipment. In addition, production may be running at risk or not operating at all while this testing is completed. Therefore, a process analytical technology where the cleaning process can be verified and validated immediately in-situ can have the impact of more usable capacity, lower cost, more consistent results, and lower risk of potential cross contamination for the patient.

These three examples were only a few of the ones that firms have brainstormed, and they illustrate the kind of problems a company faces and how PAT could help solve them.

3.3 Process Analytical Technology Options and Applications

Process Analytical Technologies are progressing at a rapid rate and were researched in this thesis. Their application for the projects' needs had to be brainstormed as well. In conjunction with this research, the application of the PAT to specific manufacturing or business issues was also analyzed. Some examples of the technologies available and their applicability to the manufacturing issues discussed in section 3.2 are presented here.

The first example listed was studying the drying process and replacing the time based endpoint with a process based endpoint. The replacement could lead to a more consistent product and shorter cycle time for the unit operation. This example is one of a point solution in which the PAT installation shows efficiency improvement on the unit operation. This efficiency improvement translates to cost and quality of the overall process, but its influence is seen at the point of installation. The team identified two PAT options to monitor the chemical attributes to accomplish this task: Raman spectroscopy and ultrasonic spectroscopy. These analytical techniques could be used and correlated to a quality control test currently being completed.

The second issue described the blending process of an API, a lubricant, and a glidant. In this process the team determined that two parameters, if measured, would provide a greater understanding of the process and potentially lead to downstream optimization. This issue is an example of a process PAT solution where the improvement to efficiency is seen in a downstream process step. These two parameters influence the subsequent steps and not necessarily at the point of installation. These two parameters are the amount and the distribution of the lubricant and the glidant in the blend. In addition, the blend uniformity is a parameter that is typically performed as per the filing procedures with the FDA. Potentially, a technique used to determine amount of excipients and their distribution could not only be used for the validation run criteria, but also for continuous monitoring to predict downstream compression performance. Three PAT options available were near infrared spectroscopy, near infrared chemical imaging, and Raman imaging.

The final issue described was the validation that the cleaning process for the vessels used in formulation was complete. Swab tests normally look for product and detergents left on the process vessel walls. Replacement of the highly variable swab test could prove useful. Two process analytical technologies that could potentially detect the small amount of product and detergent necessary to ensure that vessels are clean are ion mobility and mid infrared spectroscopy.

As a side note, the cleaning process ensures that microbes are not present and find their way into subsequent batches. Currently, most firms are using microbial detection methods that can take anywhere from two to fourteen days (Mehta and Jeong 2003). Unfortunately, a PAT solution is not on the market yet, but a test called ATP Bioluminescence has been proven to identify microbes in approximately 10 hours (Mehta and Jeong 2003). Much work has gone into this area of research.

The three example PAT situations described above were repeated for the many manufacturing issues that the team listed and brainstormed. A list of approximately 40 manufacturing issue – technology pairs was developed.

3.4 Failure Mode and Effects Analysis of the Issue-Option Pairs

The team used the FMEA process to prioritize its issue – technology pairs. The three examples described in sections 3.2 and 3.3 are continued in this section to illustrate the team process used to score the severity to the business (S), frequency of the issue occurring (F), how easy is the detection of the issue by the specific PAT (D), and the ease of implementation of the PAT (I).

Table 3.3 – Summary of Scoring

Issue	S	F	PAT	D	Hurdles?	I	RPN
Drying	1	1	Raman	2	Sampling	2	4
Drying	1	1	Ultrasonic	1	Sampling	1	1
Blending	2	1	NIR	1	Sampling	3	6
Blending	2	1	Chemical Imaging	1	Sampling	3	6
Blending	2	1	Raman Imaging	1	Sampling	2	4
Cleaning Validation	2	1	Ion Mobility	2	Sampling	1	4
Cleaning Validation	2	1	Mid-IR	2	Regulatory	2	8

The team scored each PAT technique and its implementation for a particular project individually. However, the values that the team scored initially may be modified as feasibility studies occur which makes the overall process somewhat iterative. Therefore, the detection (D) score may drop after testing. In addition, sampling was highlighted as a hurdle for many projects. However, through some in-process studies, it may be determined that sampling techniques are easier than expected. Therefore, the ease of implementation score would increase.

The team’s initial review and scoring was necessary in order to prioritize where the team’s efforts should be spent. Due to limited resources, the team had to focus on a short list of projects. However, the highest Risk Priority Number projects were not taken blindly. The team also compared the results of the scoring with their experience. This process focused the team on a short list of two to three projects. These projects would progress to the rigorous business evaluation. The rest of the projects were held until their priority was raised to the top of the list.

Overall, the distribution of project scores was well spread. There was no clumping of scores at one specific number. If the scoring was skewed in one direction or another, it would have been necessary for the team to re-evaluate its results. However, the scores follow what one would expect for a mature product, yet not fully understood manufacturing process: a higher concentration of projects in the middle of the RPN range, but not overwhelming so. I would expect this type of distribution because much

has probably been learned about how to manufacture a mature product, but root cause analysis for yield loss, as an example, may not be fully understood. Figure 3.1 shows how many projects scored each particular Risk Priority Number versus the potential scoring scenarios. This chart shows the data collected after the team's initial review.

Figure 3.1 – Number of Projects at Each Potential RPN Score

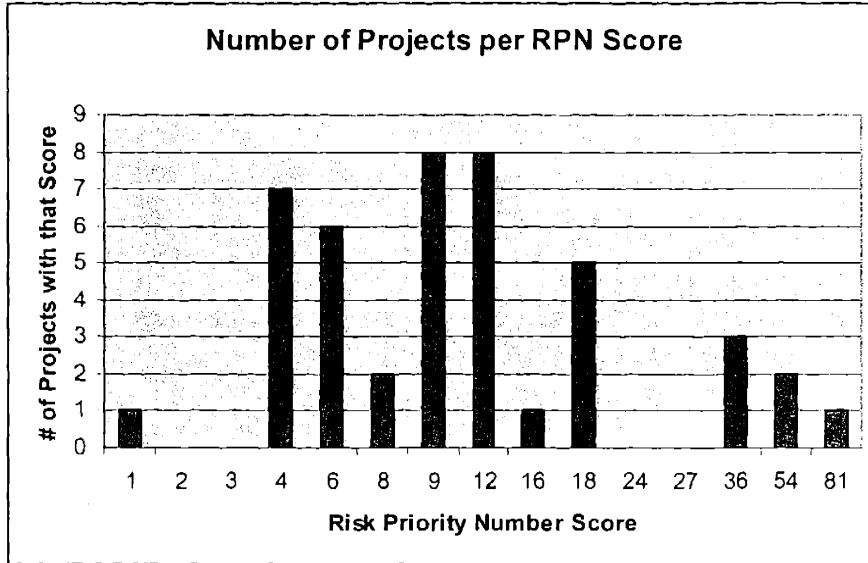

In addition, the data for how the team scored projects for each individual category is shown in Figures 3.2, 3.3, 3.4, and 3.5.

Figure 3.2 – Number of Projects at Each Potential Severity Score

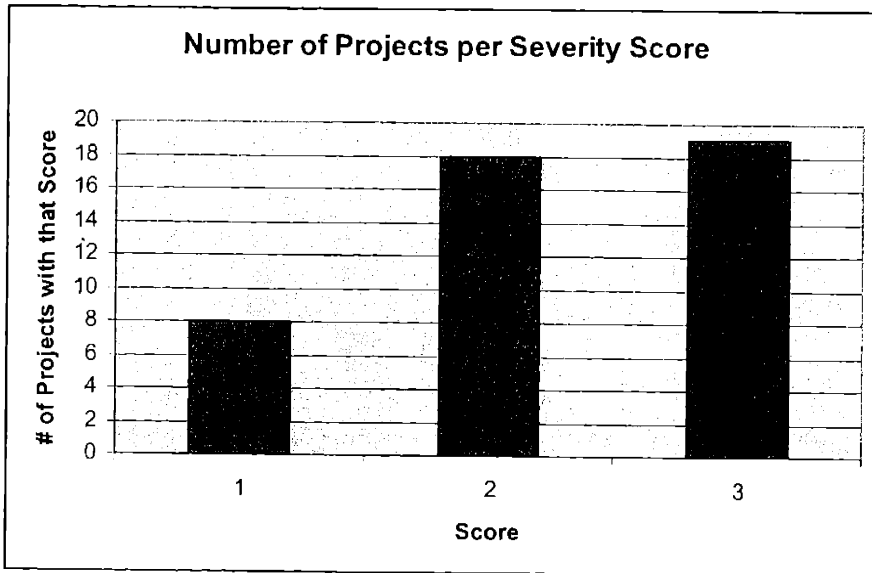

Figure 3.3 – Number of Projects at Each Potential Frequency Score

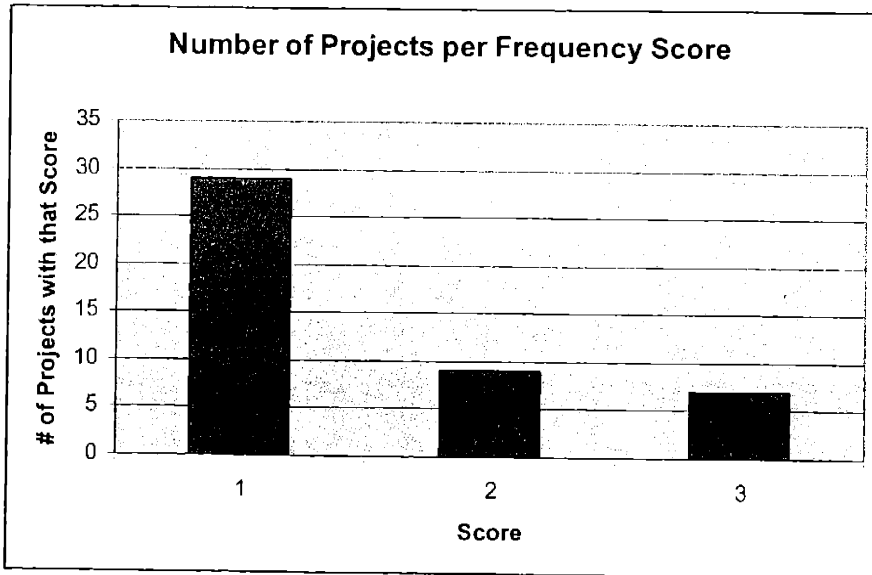

Figure 3.4 – Number of Projects at Each Potential Ease of Detection Score

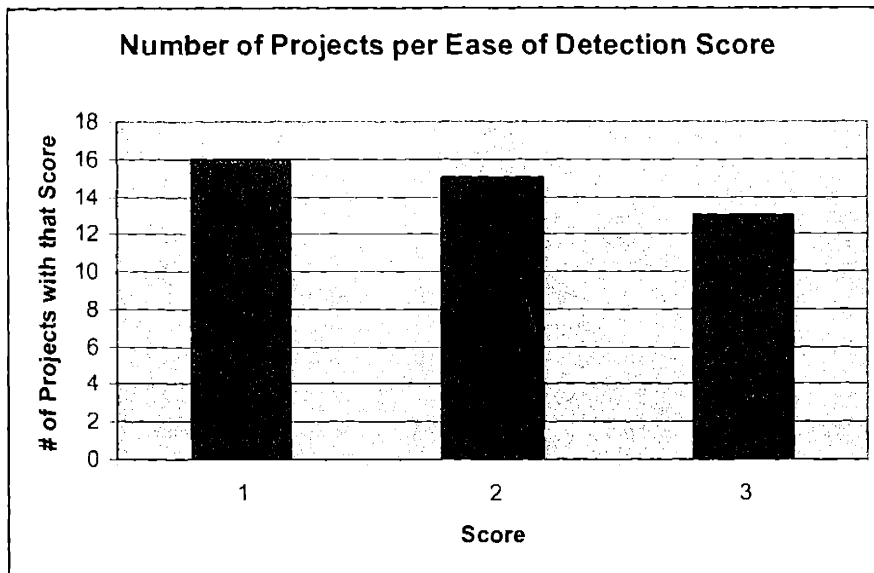
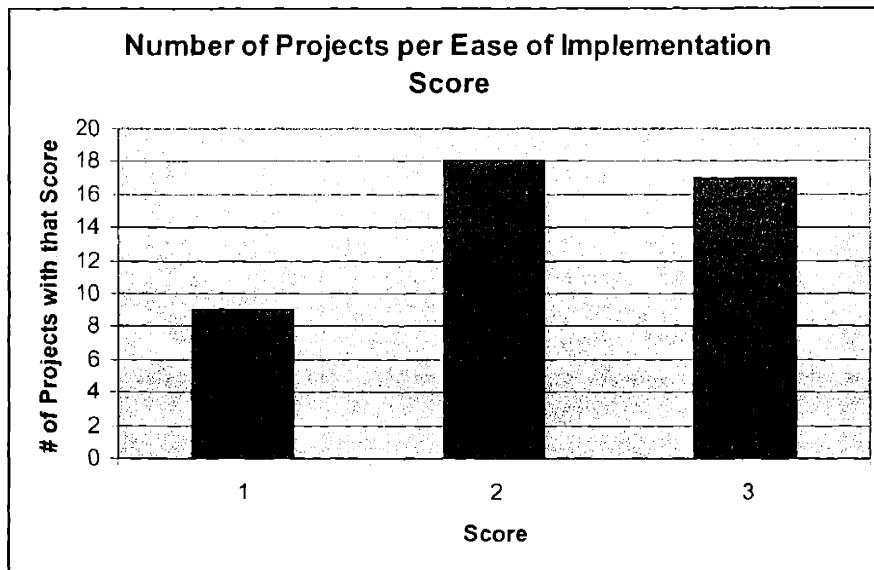

Figure 3.5 – Number of Projects at Each Potential Ease of Implementation Score



In studying the individual category scores, a few highlights are noticed. The first is that, in my opinion, the projects on the list developed have a high probability of affecting the business severely, but they are not expected to occur very often. This opinion is not

surprising because the process to manufacture Renagel® is a batch process. Something unmonitored could cause an entire batch of material to be scrapped. The impact to cost of goods sold if one batch is scrapped is significant. However, after completion of the “bad batch” and starting of the next batch, the process may have shifted back to normal. Meanwhile, quality control testing may not be done for some time.

The second highlight is that the ease of detecting the difference necessary to make an impact is evenly spread across the scores of 1, 2, and 3. This means that some of the technologies may be mature enough to provide a good solution to the issue, or that the manufacturing issue is understood well enough that a PAT solution is clear. On the opposite end of the spectrum, other issues may be tough to quantify, or perhaps the Process Analytical Technologies are not fully developed for this application. Regardless of the score that a project received in this category, some feasibility study is required.

The final interesting highlight of the data is how highly skewed the Ease of Implementation scores were. For the most part, the projects were judged to be of at least average ease of implementation. Through some study of the data, there looks to be little resistance overall to the concept of PAT by the overall organization, and the fact that senior management has supported the project from the onset means that the toughest part of implementation may be understanding the regulatory environment and ensuring adequate sampling techniques. In addition, editorials written in trade journals such as the American Pharmaceutical Review, describe an implicit two step process of implementation. First, “for information only” monitoring is easier to implement than the second step of monitoring for control purposes. Many of the team’s project ideas fit into this mode of thinking, which leads to scores that reflect a higher ease of implementation. Therefore, in my opinion, the highly skewed ease of implementation scores are more a function of specific situation and less a general trend across the entire pharmaceutical industry.

3.5 Summary

This section described the method of identification and prioritization of the manufacturing issue – technology option lists. The process used was a Failure Mode and Effects Analysis (FMEA). Upon completion of this process, a small number of high priority projects were elevated. This short list next must be evaluated for technological feasibility and economic merits. This evaluation is necessary to ensure these projects are useful to the business and not just engineering pet projects.

The high impact lessons from the identification and prioritization process were that

- A pre-approved prioritization process kept the team objectively focused on true project impact.
- The ease of implementation category was an important characteristic of measuring the regulatory environment and must be included in a PAT project analysis.
- The overall analysis of the distribution of FMEA scores ensured that the team's outcome was fairly portrayed.

Chapter 4: Evaluation of the High Priority Projects

With a fundamental change to production operations, such as Process Analytical Technology, there can be a tendency to assume that all proposed projects can have positive ramifications for an organization. Many times, a firm may not complete a rigorous business evaluation because the project may “feel like the right thing to do” or “the whole industry is doing it, we should too.” This chapter challenges these assertions and proposes a process for evaluating a fundamental shift, like PAT, in the regulated pharmaceutical environment.

4.1 Purpose of the Evaluation

The evaluation of the high priority projects was necessary for a number of reasons. The main reason was that the Failure Mode and Effects Analysis was an excellent method for prioritizing a large list of projects, but it provides no business justification for the movement forward with an actual implementation. A business evaluation is necessary because the financial merits, the intangible costs and benefits, and the overall strategic direction of a project should be studied prior to implementation. By looking at the projects this way, the possibility of an unprofitable project being undertaken is less likely. In addition, a team that has evaluated a project will be more likely to understand the exact goal and therefore be able to achieve it.

However, evaluating new technologies in a regulated manufacturing environment does have its challenges. The pharmaceutical industry has been loath to undertake manufacturing efficiency projects for fear of the regulatory hurdles. The fundamental shift of Process Analytical Technology cannot be evaluated on the merits of net present value or return on investment alone. It is important to study the intangible costs and benefits, as well as the financial ramifications.

Intangible costs and benefits for Process Analytical Technology are varied. As an example, one of these intangible benefits is that the initiative is new, and the technologies involved are being improved upon rapidly. This means that some cost now could lead to higher future payoffs than predicted. Another one of these intangible benefits is training the organization now on PAT can lead to easier acceptance and implementations in the future. This could become vitally important in a rapid continuous improvement process deployment situation.

Probably the largest intangible benefit is the guidance around the FDA's new cGMP risk based auditing future plans. The FDA expects auditing resources to be constrained in the future. This constraint is due to current policies that do not line up with how much risk a patient is under because of the product type or process background. As the Wall Street Journal published on September 3, 2003 (Abboud and Hensley 2003), "The FDA's initiative focuses oversight on the plants and process that are most at risk for errors that could hurt patients." This means that the better a firm understands their process, the less risk there will be perceived to be by the FDA. By investing in PAT, a company has a way to lower its risk level.

The evaluation also must ensure that technological feasibility has been checked. While this is not a large part of the tool developed here, the basic questions that must be verified are explored as well. By asking these questions, a bad situation of sub-optimal use can be avoided by ensuring the intended need is justified and able to be detected. In addition, technical feasibility studies can help a team better define its scope.

4.2 Technological Feasibility Evaluation

The evaluation tool contains a section on technical feasibility. This portion of the model is available to ensure that the team has checked some high level goals on how successful the equipment is in detecting the needed values. It is not designed to be all encompassing, but is present solely for reminding the team that many different facets must be checked prior to proceeding with the complete evaluation. Many times, this

section may help the team specify the scope better, or help bring together the group's needs for a completely well understood project.

The list of technological feasibility questions are listed below.

- How does the process analytical technology work?
- How repeatable and reliable is the new analytical technology expected to be?
- Can a statistical model be developed and is it apparent in the feasibility study?
- Are the data collection conditions robust (i.e. - does it work in high or low temps, high or low pressure)?
- What is a rough implementation plan for developing a robust and repeatable sampling technique?
- Is the training reasonable for the operators of the new equipment technology?
- What will need to be the statistical analysis method?
(Univariate/Multivariate/SPC)
- Is the equipment or method 21 CFR Part 11 compliant or does it not need to be?
- Is the software interface for the analytical technology easy to use and reliable?
- How useful is the hardware and software documentation on the equipment technology?
- How good was the vendor's support during the feasibility study?
- How often is the equipment technology's software revised? If they are necessary, how committed has the vendor been to providing timely and easy updates to the software?
- How secure is the software and hardware on the new analytical technology?

As listed, this section may deal with the Information Technology interfaces needed, the statistical modeling tools needed, or how easy the process analytical technology is to operate. It is not necessarily strictly defining sampling plans or level of use. It is expected that these are part of the full implementation because of the rigor needing in developing these robust, predictive models.

4.3 Intangible Costs and Benefits Evaluation

The most difficult portion of the evaluation is to quantify the intangible costs and benefits. Intangibles are sometimes referred to as the soft benefits or costs. It is very important to analyze these benefits and costs for new technologies as they can make a fundamental change to a production line. Therefore, it is difficult to measure the exact financial benefits or costs that may come about from the analytical technology. As a fundamental change, other industries can be benchmarked, as discussed in Chapter 2, but this benchmark can only be extrapolated so far. Therefore, in the pharmaceutical industry, like in any industry, senior managers are going to want to ensure that a team has given all economic costs and benefits due analysis. This reason is why the intangible evaluation is most useful. It provides a framework for justifying the time and money required to bring a new PAT into the manufacturing process.

In order to attempt a useful measurement of the intangibles, a simple process was followed. This process was:

- Brainstorm a list of open ended questions that describe the intangibles
- Group the questions into a small set of categories (described below)
- Agree on “control limits” as a team for what constitutes a positive, a negative, or a neutral impact to the business unit
- Score the questions based on their impact to the overall business
- Roll up and average the scores by category and overall value (weighting is not necessary because of the qualitative nature of the data)
- Perform a “sanity check” to ensure that the overall scores make sense
- Compare the score to the agreed upon control limits and decide whether the intangible evaluation supports or rejects the project

This process provides a list of questions for the evaluators to think over. In addition, the small set of categories focuses managers when discussing intangible concerns with the project team. The scoring system provides a method for quantitative analysis, and an

agreed upon control limit gives the team the ability to say that overall a project has a positive, neutral, or negative impact on the business. Over time, many projects worth of data could help the team set more objective limits.

The five high level categories that our team developed are Current Technology Usefulness, Future Use / Future Capabilities, Political, Environmental Health and Safety (EHS), and Regulatory. The first two categories evaluate the process analytical technology's immediate impact on the process or business and its ease of expansion to future needs. The "Political" category ensures that some thought has been given to the organizational ramifications, the goals of the company in terms of technological infrastructure, and vendor resources and support. The EHS category is designed to evaluate the safety and environmental impact of the analytical technology. This evaluation does not include patient safety because it is assumed that any technology that is needed to improve patient safety will be completed. The final category takes into account the regulatory environment. This category is necessary in order to understand the ease of implementation, the audit team's expected reaction, and documentation necessary. These five categories are designed to give the team, the stakeholders, and the sponsors of any project the ability to ensure that the intangible costs and benefits are well understood.

Within each of these categories, there are many questions that should be asked to ensure proper scoring of the project. These questions can be used in general when evaluating new technologies in regulated industries. Some items may need to be edited slightly per project, but the basic premise can be understood. Listed below is a list of important intangible cost and benefit questions organized by their high level category.

Current Technology Usefulness

- What is the expected overall effect of this project on process variability?
- What is the expected duration to train the team on how to operate the process analytical technology?
- How easily does the data export to other electronic formats?

- How long has the analytical technology existed?
- How familiar is the team with the process analytical technology?
- How long has the vendor been in business? Are they a stable firm?
- What is the vendor's past experience with similar installations?

The usefulness of the current technology can be qualitatively answered by the above questions. The premise of this category is to understand what is the benefit expected and how able is the equipment technology to make an impact immediately. The vendor is also graded in order to give the evaluation team a strong idea of how much they can count on the vendor to perform well.

Future Use / Future Capabilities

- What is the potential for reuse of the process analytical technology if the plant is retrofitted to the next generation product?
- What is the expected equipment technology obsolescence date?
- Is it a rapidly changing process analytical technology?
- What is the impact to United States Pharmacopeia (USP) standards? Can specifications be tightened?
- How flexible does the process analytical technology make the production process?
- How has the vendor demonstrated commitment to their own research and development?

Future capabilities gives a deeper understanding to the team on how flexible the equipment technology may be, and how its use may fit in to the next generation products. It also gives the team a chance to think about the vendor's long term commitment. The category is intended to give the team a long term view of the analytical technology and its longevity.

Political

- What is the likely support level from the affected stakeholders (manufacturing managers, engineers, senior management, etc.) for the new process analytical technology?
- What is the overall business strategy for on-line or at-line analysis?
- Is it expected that learning how to implement this process analytical technology now could lead to higher payoffs on future products?
- Does the vendor have enough resources to support development, testing, training, and installation?
- Does the vendor have a reputation of being good at support or believing that the customer is #1?

Any project must have strong political support. This framework is intended to ask questions about how well received the process analytical technology is expected to be and how much support the team can expect from equipment suppliers, peers, and senior managers. Through analysis of the political landscape the team can better develop plans on how to work its way through approval processes and will know how to enlist backers.

Environmental Health and Safety (EHS)

- How much material exposure can be eliminated by the new technique?
- Have there been any safety incidents regarding sampling that the process analytical technology could eliminate?
- How safe is the new analytical technology to operate?
- Does the issue have an impact on the environment? If so, what?

The EHS category is easily explained as improvements to safety or environment on the manufacturing floor. It asks questions regarding effects to the operations team and maybe even proposes an elimination of a hazardous sampling method. This category is a very important one in that safety improvements to the operation of the process deserve strong and extra consideration.

Regulatory

- What is the level of regulatory complexity to make the change?
- What is the expected regulatory audit team's reaction to this project both internally and externally?
- How much regulatory documentation is needed to make the change?
- Does this move in the direction of developing the manufacturing into a low risk activity?

This final category delves into the compliance area and is designed to give the team an overall look at how difficult or easy the regulatory environment will be. It asks questions that help the team gauge audit team's reactions and the complexity of making the change. Many times this area is difficult to quantify, so it fits in well with qualitative intangible discussions.

Intangible evaluation results, when combined with financial ones give more of a complete justification on whether a program should proceed. The financial evaluation is the next area that is studied in the evaluation model.

4.4 Financial Evaluation

The evaluation tool includes a section to understand the financial ramifications of a chosen project. The purpose of this justification is not to provide an extraordinary amount of detail around the costs and benefits. It is designed more for the operation team or technology development team to analyze various scenarios and the sensitivity of the results on those scenarios. If an evaluator wanted to document all of the details, the flexibility is certainly there, but the main purpose is for rapid calculation and evaluation.

The tool developed has nine basic inputs in order to calculate net present value. These inputs are:

- Beginning year of the project

- Weighted Average Cost of Capital (WACC)
- Time horizon of the project
- Cost of capital of the project
- Cost to implement
- Cost of operating the process analytical technology on a yearly basis
- Potential benefits of operating the process analytical technology on a yearly basis
- Depreciation period
- Tax rate

There is capability to add a second year's worth of cost of capital and to push out benefits in case a project takes two years to fully implement. There also is the flexibility to add in sensitivity percentages on five categories: time horizon of the project, cost of capital of the project, cost to implement, cost of operating the process analytical technology on a yearly basis, and potential benefits of operating the technology on a yearly basis. This gives the user the ability to think in terms of best and worst case situations as well.

In order to provide the user of the model an opportunity to understand and think through all of the potential items that may fall into the cost and benefit categories, a detailed list of each of these is provided in the tool. Therefore, the senior manager of the organization can be reasonably assured that detailed ideas were inputted into the model's output.

These questions for the cost of capital category are:

- Cost to purchase the process analytical technology
- Cost of construction to install the technology
- Cost of external labor needed to start the technology up

The items characterized as cost of capital are distinctly different than the cost of implementation category. If a cost is a capital one, then depreciation can be taken into account. Upon consultation with a finance representative, the model is set-up conservatively and only accounts for obvious capital costs. All other one time costs at start-up of the process analytical technology are placed under the cost of implementation

category. In reality, many of these items may end up as cost of capital, but during evaluation a more cautious approach is preferred. This conservative approach makes a positive return on investment more difficult to achieve in the initial evaluation. The cost of implementation items to consider are listed below.

- Cost of Implementation Labor
- Cost of Implementation Office Space / Lab Space
- Cost of special equipment during implementation
- Cost of Regulatory, Quality, and IT labor needed during implementation
- Cost to train team on the new process analytical technology
- Cost of IT set-up for the equipment technology to communicate with the rest of the network
- Cost of IT if it must be regulatory compliant
- Cost of regulatory filing for the new process analytical technology
- Cost of inventory that needs to be managed to take into account the change (while awaiting approval in some countries after approval in others)
- Cost to run validation tests
- Cost to run any side-by-side tests deemed necessary
- Cost to build the statistical/chemometric model for easy trending use in production
- Cost to shutdown the line during implementation

The cost of implementation category includes many items around the regulatory complexities, management of the plant during implementation of the technology, training, and labor. Many of these items are normal for implementations in any industry. For example, semiconductor manufacturers will normally have to run side by side testing prior to implementing a change to a process. Therefore, the above list of implementation costs can be applied across many different industries and are not solely for evaluating Process Analytical Technology projects.

The final costs are for operating the equipment during its lifetime. These are the incremental expected costs to operate the PAT over and above current plant operating expenses, and are on a per year basis. These items are:

- Cost of operation for the new process analytical technology
- Cost of vendor maintenance for the equipment
- Cost of consumables associated with the equipment to be kept in inventory
- Cost incurred due to added production labor (technology dependent)

The distinction between these items and the ones listed as implementation and capital costs is that these items recur every year. They may be additional costs taken on in order to properly maintain the equipment or to operate the new equipment. Energy costs or facilities cost are also included.

The final category is potential benefits. These are the financial benefits a team would like to gain by undertaking a PAT project, or any other new technology implementation. This category of benefits can be very difficult to quantify because many of the items listed are coming from expectations around how much product will need to be made, future financial goals, regulatory environment receptivity, and operational execution. The items listed below are examples of these potential benefits.

- Cost saved due to reduced inventory carrying cost (improved process control = less inventory)
- Cost of batch failures multiplied by the probability of the occurrences
- Cost saved due to reduced production downtime (may be increased capacity leads to capital avoidance, may be increased capacity leads to more sales sooner)
- Cost of health insurance benefit that can be expected due to less operator exposure
- Cost saved preparing for less audits, if the FDA moves to a risk based auditing direction
- Cost saved due to elimination of QC test (labor + test cost)

- Cost saved due to yield improvement from the new process analytical technology
- Cost saved of reduced production labor (technology dependent)
- Cost saved due to cycle time reduction

The financial evaluation model as described is designed to be for non-financial managers and teams who must present a justification to undertake or to disposition a new process analytical technology project. However, the data analyzed in this portion of the model can come from many different departments within a manufacturing organization.

Therefore, just as it was recommended for the intangible evaluation, the process used to analyze the financial ramifications should be a team one. As a team, the line items can be taken into account or ignored. The team can decide the sensitivities to be studied. By utilizing a team process, “bookends” of the financial ramifications can be determined. Senior management will then receive one coherent message on the project’s expected benefits and costs. Senior management can then track the projects success or failure within the bounds of the team’s developed extremes.

The model is set up using widely accepted financial capital project rules. The cost of capital and cost of implementation are taken at the beginning of the year in question. The operating cost and benefits begin at the end of the first year in question, effectively the beginning of the second year. The depreciation for each year is used only to properly calculate the effect of taxes on each year’s free cash flow. It is not included as a cost per year as it is included as the capital cost at the beginning of the project. The weighted average cost of capital is the rate in which a firm believes it could invest the cash in the free market.

As an example of the financial evaluation, assume the following fictional inputs into the model are as shown in Table 4.1:

Table 4.1 – Example Inputs into the Financial Evaluation

Project Name:	Example Evaluation	Sensitivity (+/-)
Begin Year	2004	

Weighted Average Cost of Capital (WACC)	10%	
Time Horizon (years)	10	2
Cost of capital to purchase the technology and install it	\$ (125,000)	10%
Cost of implementation	\$ (75,000)	10%
Cost of operating the technology	\$ (15,000)	10%
Potential benefits of the technology	\$ 150,000	10%
Tax Rate	35%	
Depreciation Period (years)	5	
2nd Year - cost of capital to purchase the technology and install it	\$ (125,000)	10%
Should benefits be skipped for the first year? (Y or N)	N	

The costs and benefits shown here are typical of a PAT project. For example, the cost of capital to purchase a near-infrared spectrometer can be anywhere for \$75K-\$125K, and the cost to install it can be \$25K-\$50K. Therefore, \$125,000 is not unreasonable. The implementation cost is the next highest figure and can be quite large due to the amount labor needed to complete the statistical analysis and prepare the regulatory filing.

Finally, the potential benefits are very difficult to estimate and most teams are advised to estimate low on this figure. However, the benefits to a business unit can be large if the right project is undertaken.

As can be seen for the cost and benefits input sensitivities, a blanket 10% was assumed. The beginning year of the project is set as 2004, and the project will be evaluated over a 10 year period, with sensitivity of the time horizon analyzed between 8 and 12 years. A second year cost of capital is expected, but the benefits can begin in the first full year. The need for sensitivity analysis in the evaluation is important due to a high amount of estimation that goes into the input figures. The numbers entered should be justifiable to the team and to the team's stakeholders. The output of such a scenario would look like the data shown in Table 4.2.

Table 4.2 - Example Output of the Financial Evaluation

<u>Example Evaluation</u>	<u>Sensitivity Factor</u>	<u>Value</u>
---------------------------	---------------------------	--------------

NPV baseline		\$ 291,888
NPV + time horizon	2	\$ 350,604
NPV - time horizon	2	\$ 220,842
NPV + cost of capital	10%	\$ 274,658
NPV - cost of capital	10%	\$ 309,118
NPV + cost of implementation	10%	\$ 284,388
NPV - cost of implementation	10%	\$ 299,388
NPV + cost of operating	10%	\$ 285,897
NPV - cost of operating	10%	\$ 297,879
NPV + potential benefits	10%	\$ 351,798
NPV - potential benefits	10%	\$ 231,979
NPV Best Case Scenario	-	\$ 448,410
NPV Worst Case Scenario	-	\$ 138,895
Payback Period	-	2.4 years

The baseline net present value for the “Example Evaluation” project is \$291,888. Because this is a positive value and assuming the intangible evaluation and feasibility study passed, the decision should be to undertake the project. The payback period is not unreasonable at approximately two and a half years. Even with the best and worst case scenarios calculated (\$139K to \$448K), the project still has a positive net present value. This outcome is a good signal that the project is a good one to approve. The model also provides an indication of the parameters that affect the NPV the most. In this case, the time horizon and potential benefits have the highest delta values of ~\$130K and ~\$120K respectively. Therefore, the implementation team should pay extra attention to these factors when executing the project in order to not find themselves over budget.

When studying the model output, senior management should not fixate on one output value but the range of outputs and the quality of the inputs. The fact that the input values are estimates should not be lost in the analysis or the presentation. It is even possible that some projects may be rejected or accepted because of poor estimation. However, with a strong team effort, these possibilities can be minimized. Due to all of these reasons, a team-based process stands out as the proper one for completing the financial evaluation.

4.5 Evaluation Summary

Once a risk assessment has been completed, and the top priority projects have been determined for implementing a new process analytical technology, it is imperative that an evaluation be completed. It is necessary because the relative ranking of projects does not take into account a full business justification for implementation. It is important when evaluating a fundamental change such as Process Analytical Technology, to take into account intangible as well as the financial ramifications. Many times the financial reasons for implementing a new process analytical technology do not describe the entire picture. By utilizing an intangible evaluation model, fundamental ideas of how to operate the process can be checked and improved upon. Ultimately, the decision whether to proceed on a fundamental change may not come down to positive net present value. It may come down to the long term ramifications of attempting a project in the present. The PAT initiative is not just one period or one project. It is a long-term commitment to changing the way a company manufactures its products. All of this provides strong justification for a firm to evaluate the intangible benefits as well as the financial ones when discussing a fundamental change such as the one PAT imparts.

Chapter 5 – Design of PAT Solutions

This chapter focuses on production plant designs with PAT, and how PAT can improve the quality and efficiency of specific unit operations and the entire manufacturing process. It should be noted here that there are many regulatory hurdles between the current state of pharmaceutical manufacturing and the presented potential state. However, it is useful to have a vision of an ultimate end state, and so those hurdles are ignored for the purposes of this particular discussion.

Specifically, a PAT measurement of a material attribute can give a more predictable yield and consistent product from a unit operation. The material attributes can be chemical or physical. Figure 5.1 is a process flow diagram of the manufacturing of a tablet pharmaceutical. This figure describes what I describe as the current state of tablet pharmaceutical manufacturing. It should be noted that coating and imprinting are not always required and are product specific. However, for purposes of this example, I left these steps in the process.

Figure 5.1 – Process Flow Diagram of the Manufacturing of a Tablet Pharmaceutical

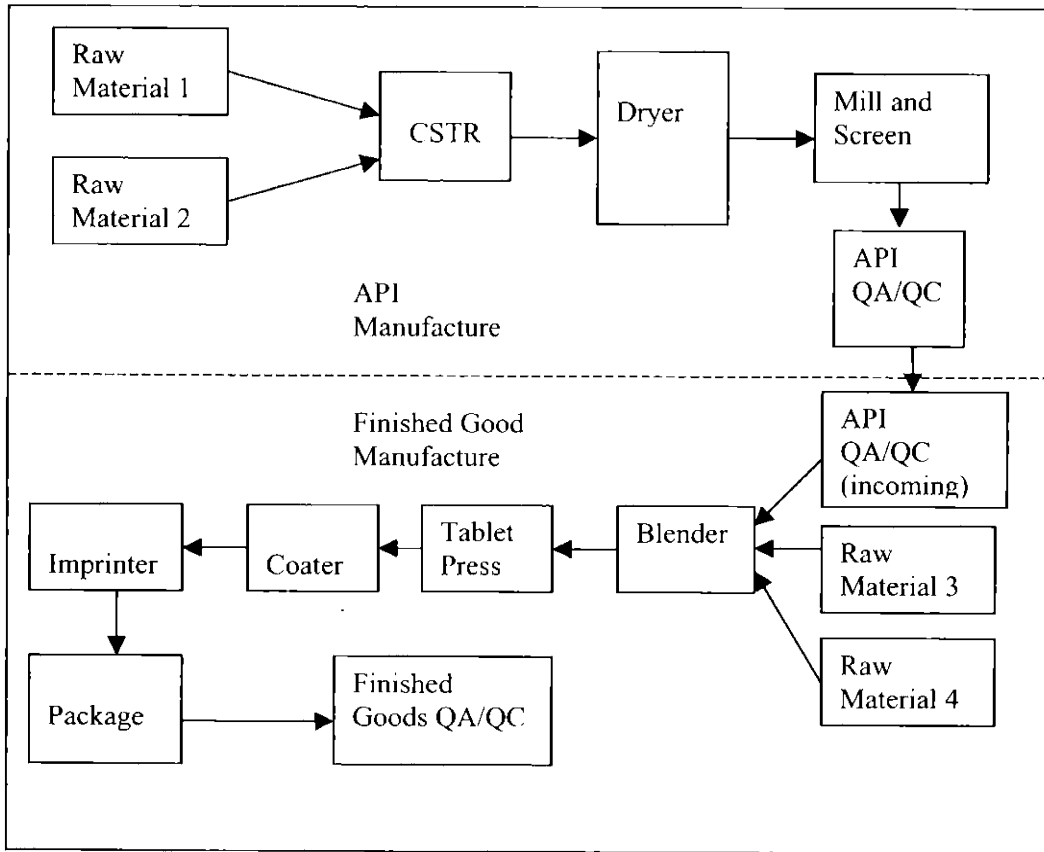

This process flow is fairly typical within the pharmaceutical industry's tablet manufacturing plants. The top half of the diagram is the active pharmaceutical ingredient (API) portion of the manufacturing process, and the bottom half describes the finished goods (FG) portion. As can be seen, each portion has its own quality assurance and quality control steps to ensure that the API factory does not send low quality product to the FG factory, and so the FG factory does not ship low quality product to patients. The specific unit operations may have some quality testing as well, but in general, the production teams rely on the quality department post production for comprehensive testing. In addition, raw material will undergo quality testing at the supplying vendor or at the pharmaceutical manufacturer or both, but at the very least undergoes identification testing at the pharmaceutical manufacturer.

PAT can enable the testing of material attributes so that process endpoints can be determined. These process endpoints can be replacements for time-based ones, which if used, can decrease manufacturing time and / or produce a more consistent end product. Figure 5.2 shows the process flow diagram of the manufacturing of a tablet pharmaceutical in a plant with multiple PAT solutions installed. Again, this is my rendition, is not all encompassing, and for the purposes of this discussion, ignores regulatory hurdles to implementation.

Figure 5.2 – Proposed Process Flow Diagram with Six PAT Installation Points

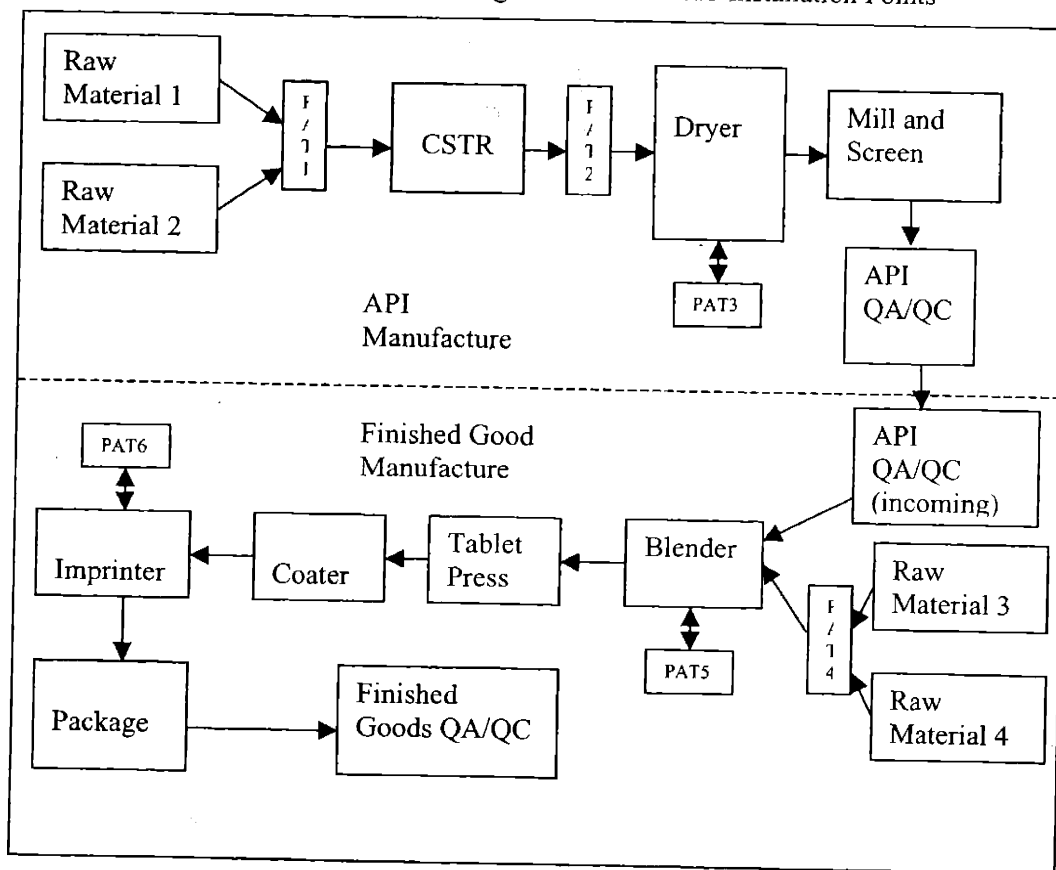

Six different PAT solutions are shown, three in the API manufacture and three in the finished goods manufacture. This next section will describe each of these points and its effect on the unit operation it is installed upon and its effect on the downstream process at large.

PAT “1” is installed where the raw materials enter the process of API production. The quality of incoming materials is of utmost importance, and it is required that vendors complete most testing to ensure it meets United States Pharmacopeia (USP) or National Formulary (NF) standards. However, a PAT measurement can consist of other tests that may not be monitored by a vendor. An example test could be the incoming concentration of a key component to the reaction process. Due to reaction stoichiometry, this concentration would be useful to understand so that only the necessary amounts of other reactants are added. The elimination of waste in reactant usage or in the unreacted key component could be a tremendous cost savings. In addition, monitoring the reactant concentrations inputted provide the possibility of developing a yield metric for the entire production process. Input concentrations can be compared against output active ingredient concentration. The amount of active as a function of input reactant concentration can therefore be tracked and maximized as a continuous improvement project. Example candidate technologies for this type of measurement are near-infrared spectroscopy, Raman spectroscopy, and mid-infrared spectroscopy.

PAT “2” measures the output from the reactor and into the drying step. Product concentration, impurity formation, or isomer extent are measurements that could be monitored. Reactor yield can therefore be tracked as a metric, and potentially controlled for through a feedback system of temperature or pressure control. This installation is a long term goal considering the current state of the regulatory environment; however, many chemical plants do this type of control already. This feedback system would be much easier to obtain regulatory approval on during the initial filing. A consistent yield from the reactor is a step towards consistent output from the overall system, which helps with forecasting a plant’s ability to meet demand and removes uncertainty from the production process. Uncertainty removal is normally worth some investment. Along the lines of product concentration, the monitoring of the water content in the output of the CSTR (which is the dryer feed) can provide information on the efficiency of the drying operation, which again provides a method for monitoring consistent yield within the unit operation and overall output of the API production system. A specific case study for how

a PAT feasibility study should be undertaken is provided here. Table 5.1 provides the samples to be checked for water content. The actual values were removed for confidentiality reasons. Figure 5.3 is the output of a generic spectroscopic method with the various samples. This technique is only workable with insoluble materials.

Table 5.1 – Water Content Output from a CSTR

Sample Number	Physical Form
1	Clear Liquid
2	Cloudy Liquid
3	Liquid & Gel
4	Liquid Gel
5	Gel
6	Damp, particulate Gel
7	Damp, particulate Gel
8	Solid, particulate Gel
9	Solid, particulate Gel

Figure 5.3 – Detailed Spectra of the Water Content Samples – Intensity vs. Peak Location

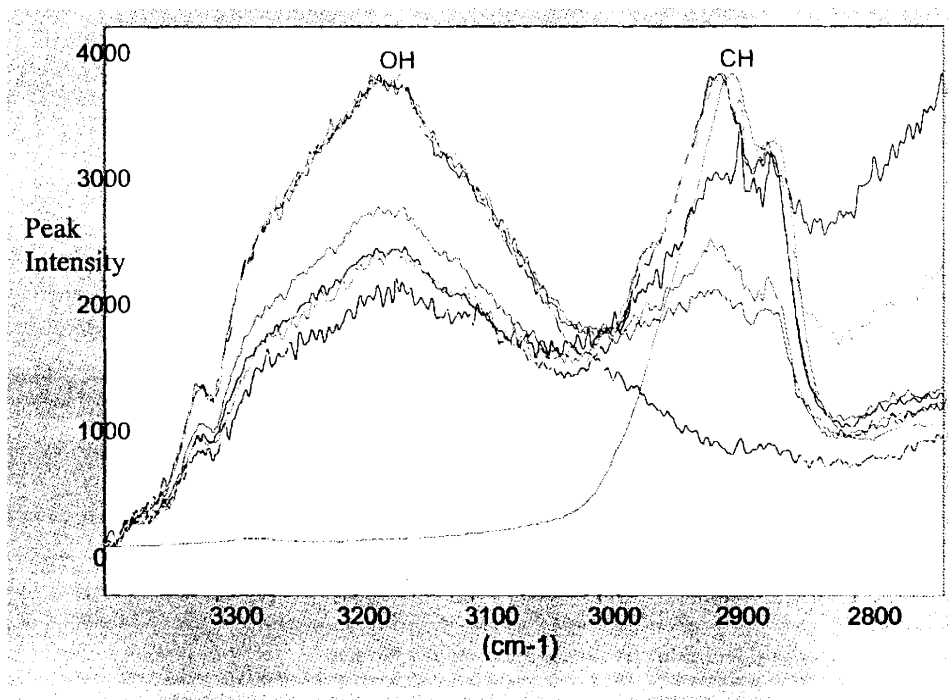

As can be seen in Figure 5.3, as the samples vary in concentration from 100% water to a high concentration of solid, the OH peak diminishes and the CH peak increases. The relative change in peaks can be used to monitor the percent water content. The ratio of the peaks was compared to the reported water content and a model was produced to understand how much error there was in the spectroscopic measurement. These results are provided here in Figure 5.4.

Figure 5.4 – Peak Ratio vs. Reported Water Content

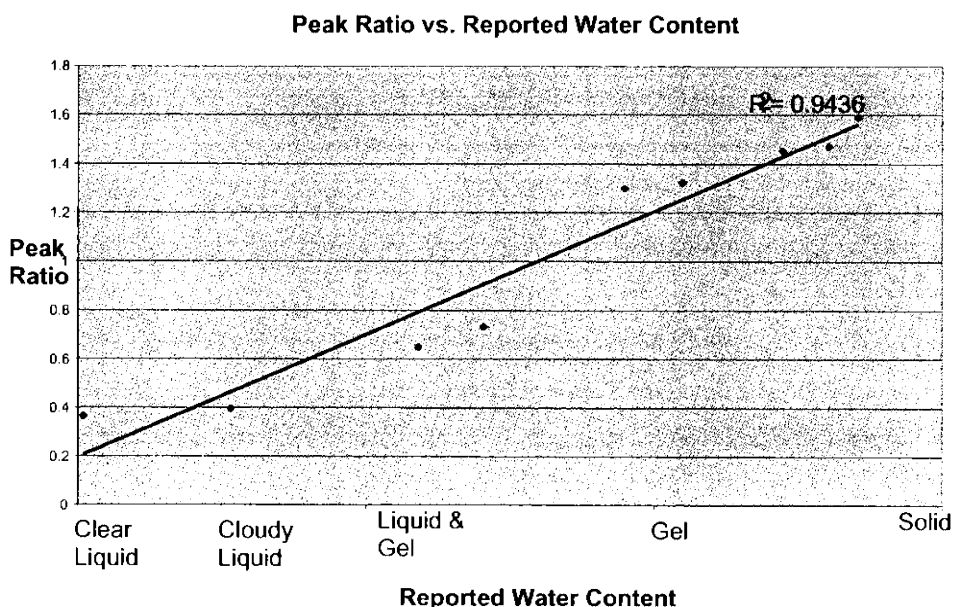

Therefore, a plant could monitor the peak ratio to determine the water content of the output of the CSTR. It is relatively simple to set up a data processing method to only monitor and calculate the two peaks. This measurement scheme monitors a material attribute and provides valuable information on the process health and provides the first part of the method for monitoring yield of the drying operation.

Referring back to Figure 5.2, PAT “3” is shown as installed on the dryer. The purpose behind this is to provide a process based endpoint for percent water weight. Currently, many pharmaceutical manufacturers develop a drying process that is time based.

Normally this is to provide a coherent procedure for regulatory filing, but it does not ensure a consistent water weight out of a dryer. Some batches may end up more or less dry, depending on the incoming water weight (see PAT 2). Of course, all batches will meet the specification as filed, but a consistent water concentration may not be present. A case study for how a PAT can be implemented on the drying unit operation was described in detail in section 2.5. Benefits described were potential cycle time reduction, a more consistent output product, higher operator safety due to less contact with the product, and potential capital equipment avoidance. An additional benefit that follows the process flow diagram for this chapter is in the QA/QC step. It is probable that water weight may be monitored at the end of API production during quality assurance. If an on-line measurement is being taken within the process, high or low failures could be caught and corrected prior to arrival in the QA/QC labs. The PAT water weight measurement therefore could have the added benefit of speeding up the cycle time in the quality assurance step.

PAT “4” is very similar to the one described as PAT “1”. It is also designed to monitor the quality of the incoming raw materials, but for the finished goods portion of the supply chain. Prior to the blending stage, many material attributes can be measured and therefore monitored (Winskill and Hammond 2001). Particle size and distribution, percent water weight, and “extra” chemical groups (O-H, C-H, etc.) on the incoming raw materials have been known to cause downstream problems. Many vendors are supplying multiple manufacturers with similar excipients, and many companies are using incoming raw materials for multiple products. Further characterization of the incoming excipients could be vital to ensuring that a blend process occurs consistently and to its process based endpoint. Some potential effects of a poorly blended material are a tablet press process that may have sticking of tablets in the punches, inconsistent concentrations of active ingredient from tablet to tablet, and inconsistent distribution of active ingredient in a final tablet. All of these effects can lead to yield loss, inconsistent product quality, and increased production costs.

PAT “5” is shown on the blender and is designed to catch and prevent many of the effects of a poorly mixed blend that were just described. A PAT, such as near-infrared spectroscopy, installed on a blending process can enable the replacement of a time-based endpoint with a process based one. Near-infrared spectroscopy has been used to monitor how well mixed a blend is by monitoring a specific peak and tracking its change throughout the blending process (Winskill and Hammond 2001). Through proper calibration, once the peak of interest reaches a specific value, the blend could be characterized as “well blended” and would be ready to move to the next step of the production process.

In addition, another PAT that has been developed by a company called Spectral Dimensions, Inc. is the development of Chemical Imaging at the near infrared wavelengths (Spectral Dimensions 2003). Its installation would typically be at-line by the tablet press (not shown), and is a post unit process type method. This technique enables the quick scan of a large area rather than what is effectively a point. Typically the technique has been utilized in monitoring tablets, which gives the opportunity to monitor how well or poorly distributed an excipient is within a blend. If a batch of tablets were measured and had inconsistent concentrations from tablet to tablet or distribution within a tablet, it is likely something went wrong in the blending step. Blending is an area where PAT has shown high impact and high reward.

The final PAT shown on the process flow diagram, PAT “6”, is an example of how optical probes or machine vision can make an impact on one of the final steps in the process. Machine vision is a technique that monitors discrete parts very well, a description of which a tablet fits fairly well. Algorithms are used to score the discrete parts against a template (Cognex 2003). A passing score means the discrete part can move to the next production step. The imprinted identifier on a tablet could therefore be monitored to ensure that it is not rotated, smudged, or faded. When a low score occurs, an alarm could alert an operator or might even be fed back to the imprinter to stop the operation. Machine vision therefore could prevent scrap material on the highly valued, nearly finished product. Another benefit would be to enable a more automated process.

As shown in this potential plant design, PAT can enable many significant benefits to a pharmaceutical manufacturer. PAT's use to monitor process endpoints could ultimately lead to many benefits, where three of the most important are:

- A more predictable yield and output at both unit operations and entire processes
- The elimination of waste material, both in-process and post-process
- A more consistent product quality because physical and chemical attributes will be controlled

These benefits are possible and within the grasp of any firm willing to invest in the improved efficiency of the factory and in shaping the regulatory environment.

Chapter 6: Implementation

After a rigorous business evaluation of a particular PAT project, assuming approval has been secured, implementation is the final step. While this thesis was not mainly focused on the execution of a new PAT project, this section is a glimpse into how a project's implementation planning process might operate. A well-rounded team of knowledgeable members is a big key to success. A lot of communication of the project's scope and schedule is best with a fundamental change such as PAT. In addition, some important planning tasks are highlighted.

6.1 Planning Process

An important facet of the evaluation process is to begin to specify the scope of a particular project. It is necessary, as a first step, to work as a team to hone the scope of the project by clearly stating the:

- Stakeholders, Customers, and Team Members
- Rationale for completing the project
- High level scope and schedule
- Objectives and deliverables
- Assumptions made when developing the scope
- Risks to success

By defining these items, a team will understand better what it will take to complete the project on-time, on-budget, and with high quality. It is much like any project a team would complete. Where PAT projects can differ greatly are in the regulatory and validation areas. It is recommended that the scope begin to be defined prior to evaluation, and be revised post-evaluation. This recommendation is because the intangible evaluation may trigger additional ideas that need to be added or can be left out of the scope.

After the scope has been solidified and approved by senior management, the team can begin working with a purchasing department. As the cost of the equipment is normally quite high, some price comparison across the supplier market should be done. A purchasing agent is normally the proper company representative for the team. There will need to be a contractual relationship set up with the chosen vendor to ensure that warranty issues, future maintenance, and confidentiality issues have been closed. It is likely that during the technological feasibility step there may have been some discussion of these items, especially the confidentiality portion. However, the purchasing department can own any of the remaining tasks.

Once the equipment has been delivered there will likely be an installation and qualification process that must be undertaken. The installation qualification (IQ), operational qualification (OQ), and, if there is process impact, process qualification (PQ) of new pharmaceutical manufacturing equipment must be completed as per regulatory rules. This leads to the next two steps which may be iterative: sampling system development and statistical model building. The sampling system is the method in which a process stream will be sampled and then presented to the analyzing equipment. Sampling may be taken through a port, through a window, or with a probe inserted into the process stream. Many PAT projects have the distinct challenge of developing a robust, reliable, and repeatable sampling plan. The presentation of the process stream to the analyzer can be very challenging, and usually is the most engineering intensive portion of a project. Once a team is confident that they have a workable plan, a statistical model can be built. Where this process can become iterative is in the analysis of the results and then a rework to the sampling system. With every change to a sampling system, a new collection of data and the re-analysis with statistical models will be required. The whole process can be time consuming due to the high number of samples required to fully characterize the variability in the manufacturing process and product.

Statistical models for complex chemical systems, such as pharmaceutical ones, may require multivariate analysis rather than simple univariate control. These models normally are also more difficult to develop. There are firms that specialize in software

packages for developing these models and making them user friendly for the entire operations team. Once a model and sampling plan have been developed and tested to be reliable, repeatable, and robust, it is time for the team to move into validation of the equipment, of the model, and of the design of the sampling system.

6.2 Team Membership

PAT exploratory organizations can be set up many ways, but during the execution phase, it is important to have a team with the right areas represented. A list of these team members may look something like the following.

- Manufacturing operations
- Process research and development
- Database or data historian manager
- Statistician
- Quality
- Regulatory
- Equipment supplier
- Team leader
- Coach

The manufacturing operations representation is necessary because of their ultimate ownership of the plant's output. This individual will need to plan for the training needed for the operations team, when best to "cut in" the new technology, and plan the production schedule for any capacity changes. The process research and development representative would most likely be the technical content expert on the analytical equipment, its application, and the manufacturing process. The R&D representative also may have had a role in developing the original process. This representative will most likely lead the effort because of their experience in making technical changes to the pharmaceutical manufacturing process.

The database manager and the statistician are the keepers and analyzers of the data that will be generated during a PAT implementation. It will be important that the data is stored and controlled. It will have to be easily accessible and will need to interface smoothly with current data systems. The database manager would own ensuring that the interface was possible. The statistician will develop the model that would be used for monitoring or controlling the material attribute in question. They would be using either univariate or multivariate analysis options as described in the previous section.

An example of how the database manager and the statistician would treat and analyze the data generated during a PAT implementation is not well documented. However, I provide an example to illustrate how it could look. A pharmaceutical manufacturer may need to monitor a dryer to ensure that a product has been dried to a certain water weight. Initially, the implementation team will need to collect data to provide a training set. The database manager will be called upon to ensure that the data is kept in a central location and easily accessible by all on the implementation team. In addition, the database manager will work closely with the statistician to ensure that the storage software interfaces easily with a statistical analysis package. At this point the statistician will build a statistical model that utilizes the data collected. He or she will develop a fit for the data that when a certain value on an analyzer is met, a specific material attribute is present. So, in the case of the dryer, two peaks may be monitored and as they change, an exact value of water weight in the product can be determined within statistical variation. Finally, once the model and analytical technology are being utilized on a day to day basis, the statistician's job becomes one of routine and on a regular basis, the model's significance should be checked to ensure the process has not drifted from its initial point.

The quality and regulatory representatives have roles that are vital for ensuring compliance of any project. The level of complexity of meeting the regulatory requirements will vary as discussed in Chapter 2. It will be necessary to have quality assurance completely understand the data being collected, ensure it is stored in a safe manner, and provide input on how the new information should be handled and used. The regulatory representative may be preparing new filings with multiple countries'

regulatory bodies. Based on this person's advice, the level of implementation may be changed or altered.

The equipment supplier's role is specifically called out because it will be absolutely necessary that the vendor is engaged in the team's effort. During installation and qualification steps there may be problems that are very complicated. These problems may not be clear initially if the equipment, sampling method, or data analysis method is the root cause. By staying engaged, the equipment supplier will be able to participate fully in troubleshooting exercises that are inevitable. In addition to its troubleshooting, lessons learned from the implementation can be fed back to the manufacturer of the equipment, and can only have a desired positive benefit for the firm as the measurement tool is improved upon. The supplier's representative also will ensure that upgrades are timely and implemented at the most opportune times.

The last two roles may be combined with other team roles, or may be separate, but a team leader and a coach are needed. The team leader will track and report progress against a schedule. They will also drive day to day implementation items. The coach will be reminding the team of business priorities, provide advice to the team leader that is a bit more strategic in nature, and will ensure funding concerns are kept at a minimum. This person is also more than likely a senior staff member who has been an advocate of Process Analytical Technology or the new technology being implemented. They may need to informally promote the team's progress and successes to help sustain their peer's support of resources and funding.

This list is provided as a guideline for the implementation team and may not be comprehensive. However, it details the important functions that must be taken into account to achieve success. An excellent implementation team will be well-rounded and ensure that all major areas are covered.

Chapter 7: Organizational Ramifications of PAT

In a fundamental technology change such as PAT, it is normal for an organization to have to change as well. This change can create conflict, but re-organization may be completed to enhance the effects of the new way of performing daily jobs. This chapter focuses on the conflicts that may be exposed by PAT in the current organizational structure, and proposes some recommendations on how to change the organization or how it operates to take full advantage of a PAT implementation.

7.1 PAT and Current Organizational Structure Conflicts

Political

Process Analytical Technology is normally data intensive. Due to the sheer volume of information generated, PAT data probably will be collected electronically. The data will normally need to be analyzed under univariate or multivariate statistical analysis. In addition, accessibility of the data by all involved is a necessity for timely resolution of problems. This situation may lead to a conflict in an organization that does not normally collect, study, or share all meaningful data. Because of the regulatory environment, the reason may be a fear of uncovering something that you are then obligated to fix. In addition to all of the data collection questions, an organization that is spread out across many sites can mean an exacerbation of the conflict.

It can be quite normal for informal networks to be the easiest mode for completing a person's job. This mode is a large reason joint technical meetings may need to be face to face rather than through teleconferencing options. Collaboration through informal channels is not unique to the pharmaceutical industry, but is exacerbated by experts who may prefer to work alone, are spread out across different countries, and overloaded with work.

Cultural

A cultural factor affecting an organization is that for real-time control of a process, data must be collected and analyzed continuously. An organization not accustomed to monitoring a process real-time can pose conflicts between manufacturing, engineering, and development organizations. In the pharmaceutical industry, since most firms use paper batch records, the feedback time on most quality data is longer than in other industries. These paper batch records may have data that is hand-entered into a database. This system leads to a situation where process control cannot occur because subsequent batches have run by the time quality control data is visible to the entire team. The delay in the system creates inefficiencies. There has been a recent shift in the FDA's position on electronic batch records, but full implementation is still many years away. Therefore, most final quality control checks occur at the end of the production process with little predictability about manufacturing performance.

A cultural facet of the organization that can lead to varied attitudes across a team can be that different parts of the supply chain can have different priorities and goals. Not in all cases, but many times, the upstream portion looks much more like a traditional chemical plant. This setup means that the equipment is normally sealed from the operating environment, a clean room work area is not required, and the operations team is trained, as in chemical plant operations. On the downstream side, the team members are gowning up to enter a clean room. The regulatory authorities normally have more scrutiny in these plants. This scrutiny can lead to a cultural difference in how much of the process can be changed or perception about quality ownership. In addition, it may not be normal for employees to change jobs and work in different parts of the supply chain. If an employee understands different parts of the supply chain and the restrictions imposed there, then he or she is more likely to support a PAT project in his or her area that improves processing efficiency elsewhere.

A final cultural trait is that the FDA and company's quality departments have historically been strongly risk averse in the production process. The aversion is clearly to protect the

consumer, since lives can be at stake. A cultural descriptor where caution is king is normal across the industry. This caution can also lead to higher hurdle rates for any continuous improvement projects in the manufacturing plant.

Strategic Design

Another potential conflict in an organization may be an organization's belief that only the quality department owns the quality of the product. Many industries have battled this perception and changed it. In the pharmaceutical industry, this problem is accentuated by the regulatory environment in which the quality assurance department is held accountable for product quality and safety. A manufacturing organization which believes that only one group owns quality will be less likely to monitor and highlight problems during the production process. In my opinion, they may only ensure that batches are produced, not high quality ones.

The design of an organization can lead to the situation as described here. Typically, in pharmaceutical firms, the manufacturing group will own the output of a factory. There will be few in process quality measurements. Theoretically, batch record requirements, if met, should lead to a high quality product, but if this theory were always true, then first pass yields for the industry would be higher. Manufacturing teams will focus on completing batch record requirements, but these do not normally go far enough to describe if there could be a failure in the chemical or physical attributes of the product. Typically, incentives for the manufacturing team are normally tied to the production goal of output. Yield may be ignored until the quality control and assurance steps are undertaken, which are post-production.

Once product exits the manufacturing process, the next step is the quality control lab tests. As has happened in many industries in the past, this group owns the quality and has little interaction with the manufacturing group. Many times, this group runs tests on the product and is judged on how fast they can complete these tests, and not on how many of them fail. These incentives can mean highly variable lab throughput times, because a

chemist will work on the “easy” batches in the queue first, while the failures wait in inventory until the group has time to work on them. There may not be joint incentives between the quality department and manufacturing to produce high quality batches quickly.

The typical pharmaceutical organization has been set up functionally, with few incentives to ensure that cross-functional cooperation occurs. Symptoms of an organization like this may be high inventory levels, high levels of scrap material, and high test rework rates. If there were an indicator of attribute quality built into the production, the operations team were trained on the technique, and incentives were properly aligned these symptoms can be minimized.

Another organizational interface conflict may be the manufacturing of the active pharmaceutical ingredient (API) and the manufacturing of the finished goods. In many cases, the API is manufactured in one plant or in one site and the finished goods are made elsewhere. At other times, multiple factories may make the API or may complete the finished goods. This setup can lead to plant to plant variability. In addition, if site incentives are not aligned with corporate incentives, organizational friction can occur. Without a product attribute measurement, it can be difficult for downstream customers to know what kind of input variables can affect the process. All of these issues mean that site incentives must be aligned with corporate ones. Openness of data across plants can be another key for success.

7.2 Recommendations for Change in Organizations Undertaking PAT

This section highlights some recommendations for a firm to better cope with the changes of PAT implementations, and ensure that the full benefits can be reaped. These organizational changes are:

- Change culture of the organizations to one that continuously improves and investigates process margins

- Structure incentives to corporate or cross-site targets where appropriate
- Perform people exchanges across portions of the manufacturing process
- Utilize an easy to use database of process data and implement standard control charts for important data sets
- Develop a continuous development process and institute a database for tracking the lessons learned

The first item listed is in line with the FDA's intention of moving to a risk based auditing culture and was described at length in the draft guidance published September 3, 2003. This auditing has typically been the case in drug development, but many times the manufacturing process has been left behind. Continuous improvement and striving to reduce process marginality will help lower the risk of yield fallout and even product safety.

The second item listed discusses proper alignment of incentives. This alignment is particularly important so that a quality and manufacturing organization share one incentive of high quality output. Production that is scrapped should hurt both groups. Alignment should help drive a desire to continuously improve and ensure that failures in the lab are fed back to the entire organization to prevent re-occurrence. In addition, corporate goals of a completed product through finished goods can help drive the upstream and downstream process steps to work much closer.

Along the same lines of driving closer working relationships, it should be encouraged to complete people exchanges throughout the value chain in order to learn where the biggest challenges are throughout the production line. It does not have to be long term but some empathy can go a long way in fostering cross functional relationships.

The purpose of the fourth item is to give the entire team more visibility to the data generated during the manufacturing process and to train eyes to watch the important process parameters. Many times by providing easy access to the entire team, ideas for continuous improvement may be provoked, which fits in with the fifth item listed. The

fifth item is to impart a continuous improvement process and tracking database. The whole process now comes full circle because the visible data can lead to new improvement ideas which can be implemented and documented. It need not be site specific in this case because a business process may be improved upon, which may be translated across the value chain.

Chapter 8: Conclusion and Next Steps

8.1 Conclusion

- PAT is intended to solve a wide range of pharmaceutical manufacturing problems, if the strategy for implementation in the plant is well designed. Potential installation designs can be focused on a unit operation or process improvement. The benefits can come in the form of improved yield and more predictable unit processes leading to more consistent output.
- Companies should perform a proper prioritization process, such as Failure Mode and Effects Analysis, and business evaluation when deciding which projects to undertake. These steps are necessary when embarking on a PAT program to ensure the plans fit into the needs of the company.
- There are many organizational ramifications of PAT both within firms and within regulatory agencies. The cultural changes are large and need to be recognized during implementation planning for a PAT installation.

8.2 Next Steps: Business Process for Sustaining Momentum

Since the inception of the PAT team at Genzyme, a lot of momentum has been generated. A difficult question however is how can the team sustain the momentum and continue to manage its manufacturing issues and potential PAT solutions going forward, when only meeting infrequently. Also, new Process Analytical Technologies are coming to market regularly, and the team must stay current on the new developments. Finally, as projects become a high priority, and can show positive overall value, implementation plans should be initiated. Therefore, a business process was developed to manage the initiative long-term. This business process can easily be extended to other pharmaceutical companies that find themselves with the dilemma of maintaining and managing their PAT programs.

A proposed business process for managing an existing PAT program is shown in the Appendix, Figure B. Starting in the upper left hand corner is the step called “Check buy-in to continue PAT program with Senior Management.” The intention behind this step is

that the PAT program will need strong and visible support from senior management. Without that support it will be impossible to take the time necessary to continue improving manufacturing processes through PAT. However, it is important that the goals for the team stay fresh and relevant. Therefore, the second step in the process is iterative with the first. This step is to “Determine and check team’s outputs / goals”. It should be stated that at the time of writing, the team’s goals were clear. The first goal is to create project scope definition statements, business evaluations, and feasibility studies of the highest priority projects. The second major goal is to determine what the high priority projects should be during the next fiscal year. However, these goals should be checked at least quarterly with the senior management sponsors to ensure they are in alignment with the current business needs.

The third process step shown in the figure is that a team leader, site representatives, and department representatives need to be chosen and / or verified. It is expected that these people will stay with the role long-term to ensure that continuity is preserved. If a team like this one has high turnover, then no progress will be achieved because of the infrequent meeting schedule. Therefore, a consistent team membership is vital. In addition, the team leader’s scope will need a clear definition. It must be determined if this individual would be the prime contact to senior management or would solely be performing a tracking and scheduling function.

In between meetings, it will be necessary to perform literature reviews and share the information with other team members. This item is listed as the fourth process step to ensure that new developments in the industry and in the regulatory environment are tracked and studied. A team dynamic established during the intensive phase of the project should ensure that the openness of new information continues to occur.

The fifth step is that the team leader should propose and check with the team an agenda for the regularly scheduled quarterly meeting approximately 2 weeks ahead of time. The lead time allows the team to properly prepare for the meeting, and get all of the important topics out for the team’s study. In addition, it can act as a reminder for everyone to finish

open action items from the previous meeting. All of these tasks are the lead up to the team's quarterly meeting, listed as the seventh step. During the meeting, there will be a standing agenda item, which is listed as step 8 "FMEA Reviewed During Meeting". Using the FMEA described in Chapter 3 as the guide, the team can continue from where it left off in the previous meeting. Here lies the biggest reason why the team representatives from each site must stay consistent. It is estimated that half of the valuable time in a meeting would be spent on explaining each item to new team members. A consistent membership is therefore vital for concise, productive meetings.

The next step in the review process includes the decision step listed as "Has there been progress on an item?" and can lead to one of two scenarios. The first scenario is that the team made no progress on an item. This scenario may mean that there are not enough resources to have worked on an issue or potentially there was not a high enough priority from the previous meeting to warrant any further work. The second scenario is that there were updates to the FMEA matrix. If so, it is important to move to the next decision step stating "Are there resources and a need for a project?". If so, then the site selected would take an action item to begin writing individual scope statements and perform the business evaluation as described in this thesis. If not, then the project will need to be held for the next quarter's meeting.

If a project is approved, then the PAT project moves to a site-driven or function-driven one, where the cross-functional, cross-site team should only be getting short updates on the progress of the project for "lessons learned" reasons. The team then moves its attention to understanding what the next highest priority project should be.

The process as described should keep the proper amount of focus and information sharing across multiple sites and multiple departments. By meeting quarterly, the site teams can continue to research new developments, and check in with the overall PAT business priorities regularly. In addition, the team can add new manufacturing issues and discuss PAT solutions to them. Once a list of potential projects is identified, the overall process to managing an existing program is suitable because scoring will not change rapidly

enough to warrant frequent updates. It is also not expected that representatives on the team are only working on PAT, so quarterly meetings should ensure a team keeps the proper focus.

The quarterly review team representatives should include at least one site member from manufacturing of the product line in question. This person will need to have a deep understanding of the manufacturing process and the science involved. A couple of other departments must be engaged as well. Two of them are the quality and regulatory departments in order to stay abreast of the PAT happenings. A third department will be the analytical chemistry team because of their deep knowledge of many of the equipment types being studied in PAT. Theoretically the analytical chemists are always studying new developments in the field and may find an application that was not previously thought about. This group should round out the important members of the quarterly PAT team.

All in all, the Process Analytical Technology initiative has high potential for changing many aspects of pharmaceutical manufacturing. Impacts to unit processes, overall process efficiency, and organizational structure and process are expected for pharmaceutical manufacturing companies who choose to embrace the initiative.

Bibliography

- Abboud, L., S. Hensley. "New Prescription for Drug Makers: Update the Plants" *The Wall Street Journal*, September 3, 2003.
- Arrivo, S. "The Role of PAT in Pharmaceutical Research and Development" *American Pharmaceutical Review*, Vol. 6, No. 2, Summer 2003, pp.46-54.
- Barrett, P. "PAT Implementation of FBRM, PVM, and Raman for Pharmaceutical Particulate Processes" Presentation at the IVT PAT Conference, June 4, 2003. <<http://www.lasentec.com/fbrm.html>>
- Broad, N., et al. "Guidelines for the Development and Validation of Near-infrared Spectroscopic Methods in the Pharmaceutical Industry" *Handbook of Vibrational Spectroscopy*, eds. Chalmers, J.M. and Griffiths, P. R., Pharmaceutical Analytical Sciences Group, NIR Sub-Group, UK,: John Wiley and Sons, Ltd., 2002.
- Bruttin, F., D. Dean. "Improving the Economics of Compliance with PAT" Presentation at the IVT PAT Conference, June 5, 2003.
- Bruttin, F., D. Dean. "Risk and the Economics of Regulatory Compliance" *PDA Journal of Pharmaceutical Science and Technology*, Vol. 54, No. 3, May/June 2000, pp. 253 – 263.
- CDER: Office of Pharmaceutical Science. 2003 <<http://www.fda.gov/cder/OPS/PAT.htm#other>>.
- Cognex Corporation. 2003 <<http://www.cognex.co.uk/>>.
- Cooper, J. "Chemometric Analysis of Raman Spectroscopic Data for Process Control Applications" *Chemometrics and Intelligent Laboratory Systems*, Vol. 46, 1999, pp. 231 – 247.
- Dziki, W., K. J. Novak. "Strategies for Successful Implementation of PAT in Pharmaceutical Manufacturing" *American Pharmaceutical Review*, Vol. 6, No. 3, Fall 2003, 54 – 60.
- Genzyme General 2002 Annual Report
- Hussain, A. "The Subcommittee on Process Analytical Technology (PAT): Closing Remarks" Presentation, February 26, 2002.
- Laserna, J. "An Introduction to Raman Spectroscopy: Introduction and Basic Principles" August 6, 2001.

- Malvern Instruments. 2003
<<http://www.malvern.co.uk/malvern/siteres.nsf/viwdocref/englabhomepage>>.
- Mehta, H.B., H. Jeong. "Strategies for Rapid Microbial Detection in the Pharma/Biotech Industry" *American Pharmaceutical Review*, Vol. 6, No. 2, Summer 2003.
- Mehta, N., J. Goenaga-Polo, S. P. Hernandez-Rivera, D. Hernandez, M. A. Thomson, P. J. Melling. "Development of an In Situ Spectroscopic Method for Cleaning Validation Using Mid-IR Fiber Optics" May 2002. Taken from
<www.brukeroptics.com>
- O'Neill, S. "Implementing Process Analytical Technology – Pfizer Global Manufacturing Case Study" Presentation at the IVT PAT Conference, June 4, 2003.
- PETA Solutions. 2003 <<http://www.thermal-instruments.com/>>.
- REMSPEC Corporation. Bruker Optics. 2003
<<http://www.brukeroptics.com/partners/REMSPEC/>>.
- Spectral Dimensions Inc.. 2003
<<http://www.spectraldimensions.com/>>.
- Spectroscopy Now. John Wiley & Sons, Ltd. 2003
<<http://www.spectroscopynow.com>>.
- Ultrasonic Scientific Ltd.. 2003
<<http://www.ultrasonic-scientific.com/tech.htm>>.
- Villacourt, M. "Failure Mode and Effects Analysis (FMEA): A Guide for Continuous Improvement for the Semiconductor Equipment Industry", September 30, 1992.
<http://www.fmeainfocentre.com/download_area.htm>
- Winskill, N. and S. Hammond. "An Industry Perspective on the Potential for Emerging Process Analytical Technologies." Presentation from CDER website, November 16, 2001.
- Woodcock, J. "FDA Regulation of Drug Quality: New Challenges." Presentation made April 4, 2002. <<http://www.fda.gov/cder/ops/scienceboard40902/index.htm>>

Appendix

Figure A - Business Process – Initial Screening, Identification, Evaluation, and Implementation of PAT Projects

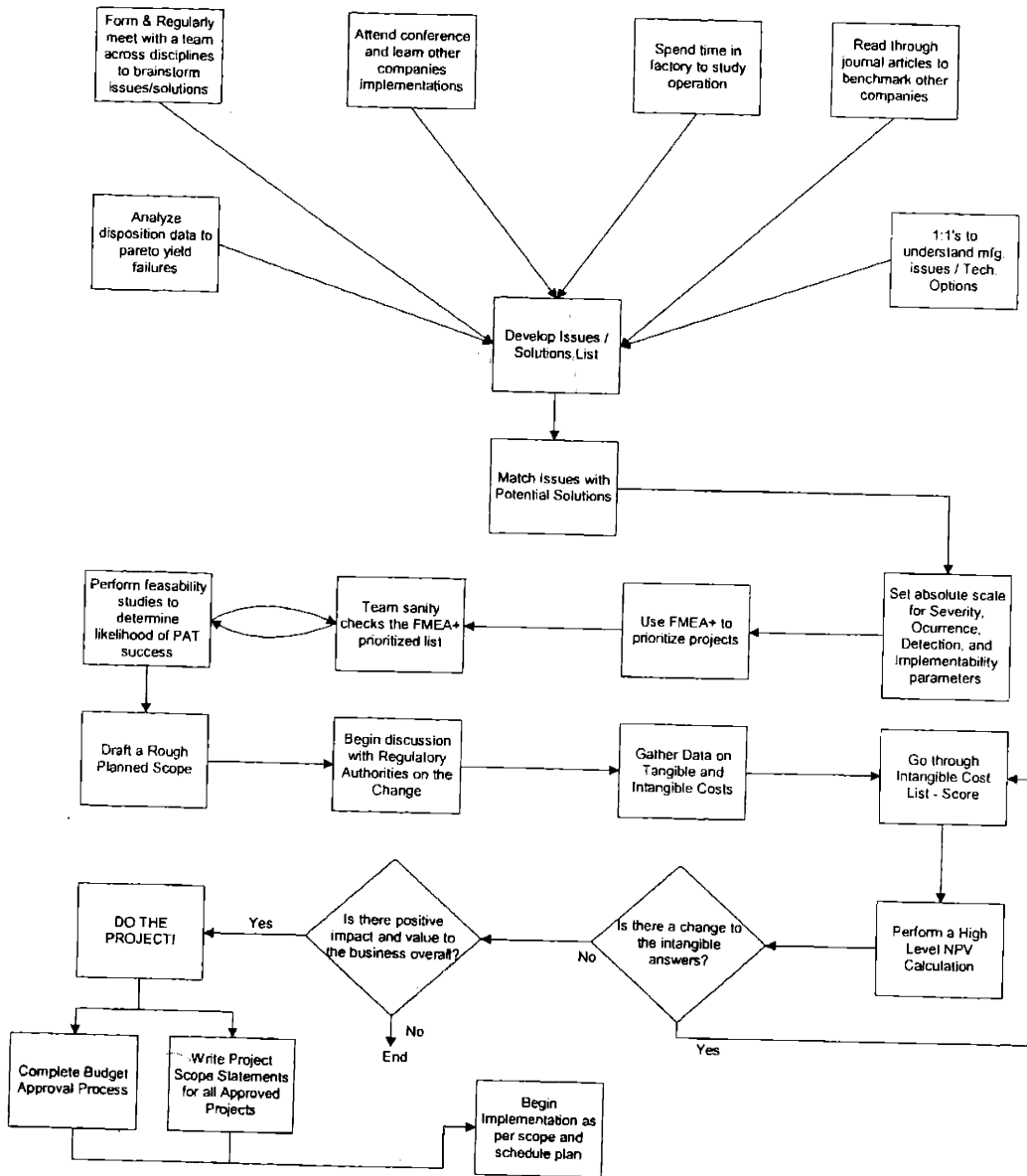
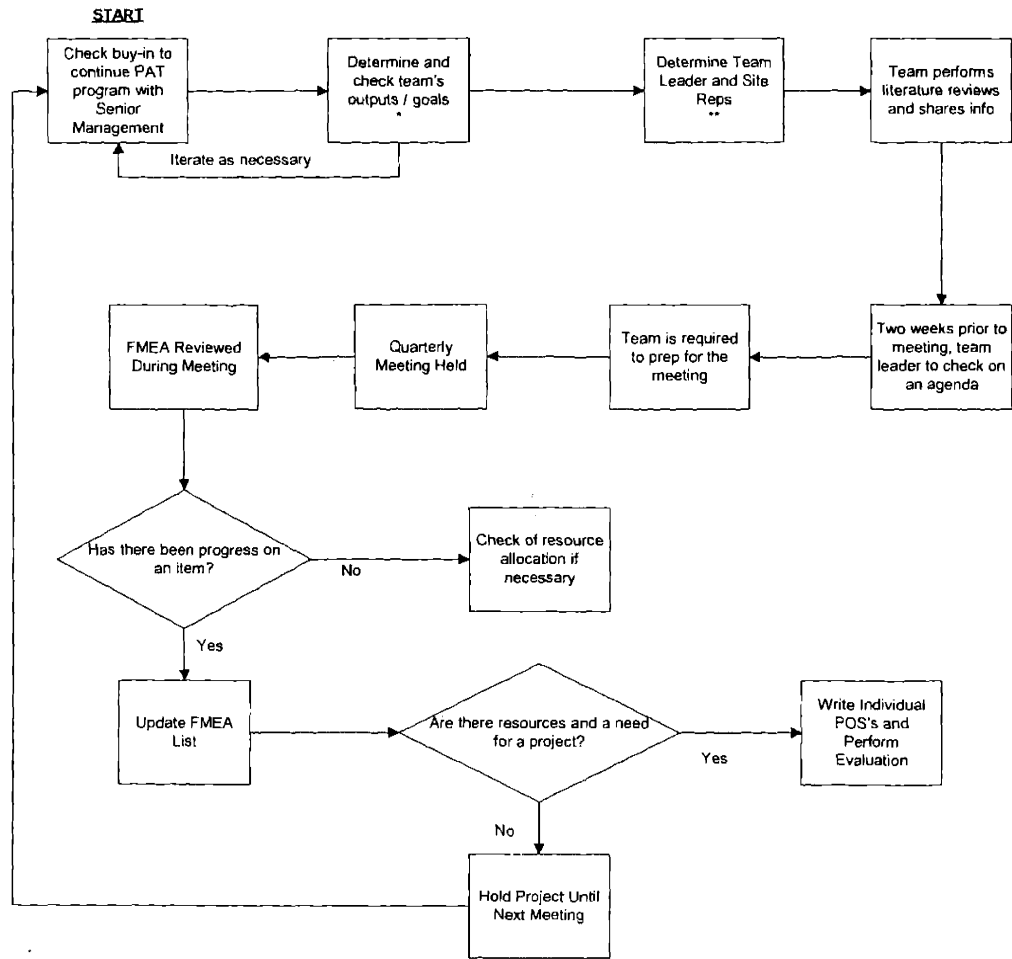

Figure B - Business Process for Managing an Existing PAT Program



* - Currently, goals are a) POS's, evaluations, and feasibility studies b) Projects determined for next fiscal year

** - Determine if team leader is the face to senior management or just performing a tracking function only
 - Each site, quality, and regulatory must have one permanent member for continuity's sake