

Concurrently Designing a Physical Production System and an  
Information System in a Manufacturing Setting

By

James Alexander Scott Katzen  
B.S. Mechanical Engineering, Massachusetts Institute of Technology 1996

Submitted to the Sloan School of Management and the  
Department of Mechanical Engineering in partial fulfillment of the  
requirements for the degrees of

Master of Business Administration  
And  
Master of Science in Mechanical Engineering

In conjunction with the Leaders For Manufacturing (LFM) Program at the  
Massachusetts Institute of Technology  
June 2003

© Massachusetts Institute of Technology, 2003.  
All rights reserved.

Signature of Author \_\_\_\_\_  
James Alexander Scott Katzen  
Sloan School of Management  
Department of Mechanical Engineering  
May 9, 2003

Certified by \_\_\_\_\_  
Jeremie Gallien  
Assistant Professor of Operations Research, Sloan School of Management  
Thesis Supervisor

Certified by \_\_\_\_\_  
David Hardt  
Professor of Mechanical Engineering, Department of Mechanical Engineering  
Thesis Supervisor

Accepted by \_\_\_\_\_  
Margaret Andrews  
Executive Director of Masters Program  
Sloan School of Management

Accepted by \_\_\_\_\_  
Ain Sonin  
Chairman of Graduate Committee  
Department of Mechanical Engineering



Concurrently Designing a Physical Production System and an  
Information System in a Manufacturing Setting

By

James Alexander Scott Katzen  
B.S. Mechanical Engineering, Massachusetts Institute of Technology 1996

Submitted to the Sloan School of Management and the  
Department of Mechanical Engineering on May 9, 2003 in partial fulfillment of the  
requirements for the degrees of

Master of Business Administration  
And  
Master of Science in Mechanical Engineering

In conjunction with the Leaders For Manufacturing (LFM) Program at the  
Massachusetts Institute of Technology  
June 2003

**Abstract**

The advancement of information technology in manufacturing requires process architects to refine their procedures used to design new manufacturing systems. No longer can these designers implement a physical production system first, and then later incorporate a capable information system to control that production system. Rather, the physical production system and the information system must be designed concurrently to ensure the resulting system yields a seamless flow of information as well as physical material.

This thesis reviews the traditional methodology used to design a physical production process. The major tools and steps of that methodology will be reviewed, and case examples will be provided showing how the traditional method is typically applied.

Two major shortcomings of the design process (the neglecting of the flow of information and its overly sequential nature) will be identified. To address these shortcomings, specific concepts, models, and methods have been developed. These new tools form the structure of an improved design methodology for manufacturing processes.

This thesis provides case examples where the new concepts, models, and methods were applied. These cases provide concrete illustrations of situations where these ideas have been successfully implemented.

The overall concepts presented are: 1) the flow of information is as important as the flow of product; 2) the flow of information is often more complicated than the flow of physical material, and frequently it is the sharing of information within a process that governs the process' performance; 3) the flow of information can be modeled as the flow of physical parts, so many of the same principles that apply to the design of physical production systems can be applied to the design of information systems; and 4) the design of an information system must occur in a concurrent fashion with the development of the physical components of any manufacturing process.

Thesis Supervisors:

Jeremie Gallien, Assistant Professor of Operations Research, Sloan School of Management  
David Hardt, Professor of Mechanical Engineering, Department of Mechanical Engineering



## **Acknowledgements**

First and foremost, I would like to thank the Eastman Kodak Company for sponsoring this work, and for its continued support of the Leaders For Manufacturing Program. Specifically, thank you to Vincent Andrews, who as a tireless project champion, made my integration into the project team a tremendous success. In addition, I would like to thank Bix DeBaise and Ron Fish, who taught me an incredible amount about digital photography and manufacturing of electronics. In addition, their backing and support of my ideas were vital to the success of my internship. Also, the following individuals all played a major role in my internship: Paul Antos, Charlie Braun, Bill Carleton, Lori Cohen, Paul Conaway, Julie Cooke, Duane Courtney, Jim Cutaia, Dan Derleth, Eric Dilella, Gerry Edd, Doug Elliot, John Gilly, Dusty Gutoswki, Tim Keefe, Malini Krishnanmurti, Richard Kurchyne, Mike Marcus, Marty Maurinus, Rae Mawn, Jim Merriman, Mark Newhouse, Dave Osterhodt, Bruce Patnuade Patricia Reibstein, Eshetu Setgen, Mike Vaughn, Danny Vindigni, Dave Wakefield, and George Wambach. Also, I was extremely fortunate to work with a truly wonderful group of highly skilled operators: Farooq Abdullah, Bernie Bakewicz, Barry Bareham, Brian Barringer, Steve Beaman, Eugene Clement, Steve Coffey, George Giordano, Eun Lee, Kilcha Lim, Ron Martin, Larry Masseth, Desi Miller, Juanita Nelson, Blanche Nix, Vicky Oliynek, Jacquelyn Phan, Kerry Posick, Barb Randolph, Brian Roller, Ed Rounds, Barb Stephens, Jill Taylor, Chris Terenzi, Mary Toepper, Marty Turner, MaryLou Williams, Bock Yim. I tremendously enjoyed my time working at the Eastman Kodak Company and on the DCS Pro 14n project. I am proud to have been associated with this group of people and with such an awesome product. I wish you all well in the future.

Kind thanks also goes to my two thesis advisors: Jeremie Gallien from the Sloan School of Management and Dave Hardt of the School of Mechanical Engineering.

In addition, I would like to thank the Leaders For Manufacturing program for its support. I would specifically like to thank my LFM brethren (Eric Green, Ankur Goel, Christine Lindsey, and Eric White) who acted as a sounding board for several of my ideas.

Finally, I would like to thank my friends and family for their moral support and their editing help with this thesis.

I dedicate this thesis to Ariel Botta. Your continued support and love means everything to me.



## Biographical Note

James Alexander Scott Katzen was born on September 13, 1974, in Queensland Australia. His parents, Jay Kenneth Katzen and Patricia Morse Katzen were lifelong adventurers, working for the United States' Department of State performing heroic roles in isolated areas of the world. Katzen has two older brothers. Timothy is a Duke University graduate and Medical College of Virginia physician and is a cosmetic plastic surgeon practicing in Southern California. David is a University of Kentucky graduate and is a computer networking consultant in Northern Virginia.



After growing up mostly in Virginia, Katzen attended and graduated from the Massachusetts Institute of Technology (M.I.T.) in 1996 with a Bachelor of Science Degree in Mechanical Engineering. It was during these years in Boston that Katzen developed his love for the Boston Red Sox.

Upon graduation, Katzen relocated to Ypsilanti, Michigan, where he worked for 5 years for Ford Motor Company. For one year, he worked as a Quality Engineer in the Ypsilanti Plant of the Electrical and Fuel Handling Division, stationed in the Manufacturing Quality Office. He then spent the next year and a half working as a Manufacturing Engineer and served on the launch team for an automotive components manufacturing complex on a Greenfield site in Madras, India. Katzen then spent another two and a half years working as a Design Engineer with Ford Racing, working on multiple racing series including Formula One, CART, NHRA, ALMS, and NASCAR Winston Cup.

Katzen then returned to M.I.T. in June 2001 to enroll in the Leaders For Manufacturing Program, where he specialized in Mechanical Engineering. He served his internship at the Eastman Kodak Company in Rochester, New York, working to launch the revolutionary DCS Pro 14n digital camera.

Upon successful completion of requirements, Katzen will be awarded a Master of Science Degree in Mechanical Engineering from the School of Mechanical Engineering and a Master of Business Administration from the Sloan School of Management in June 2003.

After graduation, Katzen will begin work as a Leadership Development Associate for United Technologies Corporation's Pratt & Whitney Division in Hartford, Connecticut.

The author's professional interests include manufacturing process design, product design, manufacturing information systems, and quality and reliability engineering. Katzen's personal interests include photography, domestic and international travel, baseball, motorsports, and urban revitalization. In his free time, Katzen enjoys hiking, camping, exploring Boston, and restoring antique cars.

Katzen may be contacted via email at [jk Katzen@alum.mit.edu](mailto:jk Katzen@alum.mit.edu)





## Table of Contents

Abstract	3
Acknowledgements	5
Biographical Note	7
<b>Part I: Introduction</b>	
1: The Challenge To Be Solved	13
2: Key Findings of Project	17
3: Organization of Thesis	17
4: Literature Review	18
<b>Part II: Traditional Methods Used for Manufacturing Process Design</b>	
5: The Systematic Layout Planning (SLP) Design Process	24
6: Adding More to the SLP Process	31
7: The Traditional Manufacturing Process Design Methodology	39
8: The Foundational Elements of the Traditional Process Design Methodology	41
<b>Part III: Case Illustrations Where The Traditional Design Methodology Was Used</b>	
9: A Physical Flow Chart For The Production of An Automotive Ignition Coil	55
10: A Physical Flow Relationship Chart for a Formula One Racecar	59
11: A Physical Flow Block Layout Diagram For Krispy Kreme® Doughnuts	61
12: Designing a Manufacturing System for an Automotive Starter Motor Solenoid Subassembly	65
<b>Part IV: Developing An Improved Process Design Methodology</b>	
13: Shortcomings of the Traditional Process Design Methodology	81
14: Addressing the First Major Shortcoming: Ignoring the Flow of Information	82
15: Addressing the Second Major Shortcoming: The Overly Sequential Methodology	108
<b>Part V: An Improved Process Design Methodology</b>	
16: Description	119
17: Benefits of the Improved Process Design Methodology	122
<b>Part VI: Case Illustrations Where The Improved Design Methodology Was Used</b>	
18: An Informational Flow Chart For The Production of An Automotive Ignition Coil	125
19: A Informational Flow Relationship Chart for a Formula One Racecar	128
20: A Informational Block Layout Diagram for a Starter Motor Solenoid Subassembly	131
21: Designing a Manufacturing System for the DCS Pro 14n Digital Camera	132
<b>Part VII: Conclusion</b>	
22: Closing Comments	169
Bibliography	171
Appendix A: Eastman Kodak Company Overview	177
Appendix B: Digital Camera Market Overview	183
Appendix C: DCS Pro 14n Digital Camera Overview	187
Appendix D: How Information Has Transformed the Workflow of Professional Photography	191



## **Part I**

---

### **Introduction**



## 1: The Challenge To Be Solved

An estimated \$500 billion is spent annually in the construction and modification of existing manufacturing facilities and over 8 percent of the US GNP has been spent on constructing new facilities each year since 1955.<sup>1</sup> This incredible level of expenditure shows that the selection, location, and design of manufacturing systems are major strategic decisions for any firm.

By using efficient facilities planning techniques, these costs could be decreased by 10 to 30 percent.<sup>2</sup> Indeed, much of the success of Japanese manufacturing companies can be attributed to their efficient design of production equipment and facilities. The challenge for firms then becomes: How to achieve efficient manufacturing facility design, maximizing production output, while minimizing resources required? To address this, firms have traditionally employed a standard design procedure that analyzes multiple aspects of a production system and then develops an efficient design that optimizes numerous performance parameters, such as overall cost, production output, and flexibility.

The development of facility layout principles has occurred since the design of steel factories and textile mills at beginning of the Industrial Revolution. The practice of factory design was formalized by designing assembly lines around the division of labor principles by Henry Ford and his contemporaries. Frederick Taylor's work led to the creation of a dedicated scientific field: Industrial Engineering. Numerous other studies and practices were developed and used since then. In 1961, Muther published the Systematic Layout Planning (SLP) process, a design methodology that has become the foundation of American manufacturing system design.<sup>3</sup>

Since then, business literature has presented numerous techniques to design factory floor layouts. Many of the methods developed recently are based on the fundamentals of Lean Production, brought to the forefront of management focus after The MIT International Vehicle Program examined the Toyota Production System (TPS) and identified some of the elements that account for Toyota's competitive advantages in manufacturing.<sup>4</sup>

Many factory design principles have now been incorporated into advanced computer software applications that assist in layout design. Modern computer applications can optimize a process layout based on minimizing quantitative or qualitative factors, such as total distance traveled by a part or the ease of material replenishment.

---

<sup>1</sup> Production And Operations Analysis (4<sup>th</sup> Edition), Steven Nahmias, McGraw-Hill/Irwin, New York, New York, USA, 2001, Page 557.

<sup>2</sup> Ibid.

<sup>3</sup> Systematic Planning Of Industrial Activities (SPIF) – Volume I, Richard Muther and Lee Hales, Management & Industrial Research Publications, Kansas City, Missouri, USA, 1979.

<sup>4</sup> The Machine That Changed the World: The Story of Lean Production, James P. Womack, Daniel Jones, Daniel Roos, HarperCollins Publishers, New York, New York, USA, 1991.

Early software applications promised that simply by defining a few process parameters, optimal process layouts could automatically be generated. Process engineers could therefore focus on other aspects of a process, rather than concerning themselves with optimizing the layout of the process. The layout of a factory would quickly become an automated task, which would thus fit nicely with the cultural movement towards automated production facilities. “During the 1980s, the predicted scenario was for a future populated with unmanned factories, which were to be highly automated and integrated both internally and externally.”<sup>5</sup> Indeed, manufacturing was viewed as an afterthought; a task that could easily be accomplished, once the proper system had been implemented. “The lights-out factory of the future [captured] the imagination of almost everyone.”<sup>6</sup>

However, process engineers quickly realized that manufacturing could not be trivialized. The design of a process layout couldn't simply be reduced to a system of linear equations. Simply, there are many aspects of facility design that cannot be represented in mathematical terms. For example, only a human can evaluate whether a process design will result in better communication and teamwork between operators. Only a skilled designer will be able to tell whether or not all of the important stakeholders are truly supportive of the proposed design. And no computer program will be able to demonstrate the process design's strengths as it negotiates for project approval from senior management.

Therefore, even if a process architect does utilize one of the modern software utilities to design a process, the designer must still possess a thorough understanding of underlying design principles and methodologies that are involved in manufacturing process design.

In recent years, the dedication towards improving manufacturing has been reenergized. What was once considered an afterthought has now become a vital factor that determines the ultimate success of an organization. In fact, dramatic efficiency improvements in manufacturing processes must be achieved for a firm to compete in today's global marketplace.

But many firms have a long way to go. For an average manufacturing firm, 95% of time that a physical part is on the factory floor is spent sitting idle, while 3.5% of the time is spent waiting for a

---

<sup>5</sup> “Information Technologies For High-Performing Processes”, Cipriano Forza, Kathrin Tuerk, Osam Sato, High Performance Manufacturing: Global Perspectives, Roger G. Schroeder & Barbara B. Flynn (Editors), John Wiley & Sons, Inc., New York, 2001, Page 116.

<sup>6</sup> “Simplification Before Automation”, Hal Mather, Integration and Management of Technology For Manufacturing, E.H. Robson, H.M. Ryan, and D. Wilcock (Editors), Peter Peregrinus, Ltd., London, England, United Kingdom, 1991, Page 5.

machine to be setup or torn down. That means a part is actually having value-added work performed only 1.5% of the total time!<sup>7</sup>

Much effort is therefore placed on improving individual manufacturing processes. However, even if the entire setup/teardown time is removed and the processing time for each operation is slashed, the bulk of the time that a part spends on the factory floor will remain untouched. Thus, the traditional focus on local process optimization will not lead to overall system optimization.<sup>8</sup> Process architects need to recognize that “rather than each function attempting to optimize individually its operation, optimization of the overall enterprise must be the primary objective.”<sup>9</sup> Therefore, in addition to focusing on improving the processes themselves, designers must place even greater emphasis on integrating the entire manufacturing system and transforming it into a seamless flow of parts and information.

“Recognizing that all participants in the enterprise...contribute to the success of the operation, the search for improved ways to create competitive products must affect them all. We can improve the competitiveness of U.S. manufacturing only when we have come to understand the factors that affect productivity of each of the segments of the manufacturing enterprise as well as the interaction among them. This search for new understanding implies a special need to improve the tools that are used to analyze and design systems of the complexity of a manufacturing enterprise.”<sup>10</sup>

Yet many firms still do not understand or feel the urgent need to transform their practices. Still others are aware of, but fail to implement the best practices of process design. In reality, many designs have never been adapted from the first day the equipment was placed on the production floor. Other designs have morphed over time from an efficient layout to a complex network of distinct operations. Even other processes still utilize process designs originally developed for a now obsolete product family.

There are many diverse reasons for this lack of optimal process design. One major reason is due to the lack of opportunities that exist for total process redesign since there is often a very small time period where a process can be designed or modified. Once a process has been put in place, the pressures of production dominate and prevent any improvements in the process design from being implemented.

---

<sup>7</sup> Integrated Process Design and Development, Dan L. Shunk, Business One Irwin, Homewood, Illinois, USA 1992, Page 39.

<sup>8</sup> “CIM Development: A Strategic Management Issue”, K.B. Chuah, Integration and Management of Technology For Manufacturing, E.H. Robson, H.M. Ryan, and D. Wilcock (Editors), Peter Peregrinus, Ltd., London, England, United Kingdom, 1991, Page 151.

<sup>9</sup> “Designing An Information System For Integrated Manufacturing Systems”, Ulrich Flatau, Design And Analysis of Integrated Manufacturing Systems, Ulrich Flatau (Editor), National Academy Press, Washington, DC, 1988, Page 61.

<sup>10</sup> Design and Analysis of Integrated Manufacturing Systems, W. Dale Compton (Editor), National Academy Press, Washington, DC, USA, 1988, Preface.

Unfortunately, the only opportunities to adjust a process design usually happen when a piece of machinery is being replaced, or a major equipment failure occurs. Even then, the brief window that exists only allows minor process improvements to be made.

“The nature of a growing business is such that with all the time pressures new equipment tends to get put in a spare corner rather than finding where the most logical place for it would be. And there it remains until years later when people get sick of the mess and inefficiency. The trouble is when it comes time to make the big move nobody is sure where the best spot is for all the machinery and equipment.”<sup>11</sup>

For that reason, process designers must take full advantage of the precious moments they receive to redesign a manufacturing process. The importance of the process’ physical design cannot be overstated.

“Without precise process designs...employees have little chance of consistently operating in ways that customers find convenient. They will have even less chance of successfully performing and coordinating the broader range of activities needed to deliver higher levels of value-added. As work gets more demanding and more complex, process becomes absolutely essential.”<sup>12</sup>

Therefore, when those windows for change open, it is critical that a process designer follow a systematic and structured procedure to developing a process design.

This thesis will present a review of the traditional process design methodology used to design a manufacturing production system. This methodology will be a synthesis of the SLP process developed by Muther and improvements that have been made to that process since its introduction.

Two major shortcomings of the traditional design process will be identified. The first limitation involves the neglecting of the importance of the flow of information when a physical production system is designed. The second is the overly sequential nature of the design process, which increases overall planning time and cost.

To address these shortcomings, specific concepts, models, and methods have been developed. These new techniques will focus upon the design of manufacturing information systems and the concurrent design of the physical and the informational design systems. When combined with the traditional design method, these new tools form the structure of an improved design methodology for

---

<sup>11</sup> “How To Design The Best Layout For Your Factory”, Queensland Manufacturing Institute Ltd. Newsletter, September 2001, <http://www.qmi.asn.au>.

<sup>12</sup> The Agenda: What Every Business Must Do To Dominate The Decade, Michael Hammer, Crown Business, New York, New York, USA, 2001, Page 57.



manufacturing processes. The end result will be a design methodology that will support the concurrent design of physical flow and informational flow manufacturing systems.

## **2: Key Findings of Project**

The advancement of information technology in manufacturing requires process architects to refine their design procedures used to develop a new manufacturing system. No longer can these designers implement a physical production system first, and then later incorporate a capable information system to control that production system. Rather, they must design the physical production system and the information system in a concurrent fashion to ensure the resulting system yields a seamless flow of information as well as physical parts. Only by considering the sources, the needs, and the uses of information for each and every process element will the design team avoid creating the “Islands of Automation” that plague many over-complicated manufacturing systems.

This thesis presents concepts, models, and methods used to examine and design the flow of information through a production system. These methods are based upon existing practices that have traditionally been used to design manufacturing processes. The thesis presents that information flow can be represented as a flow of physical parts. Because of this, many of the same principles that apply to the design of physical flow production systems can be applied to the design of informational flow production systems.

This thesis provides case illustrations where the presented concepts, models, and methods were applied. These cases provide comprehensible and concrete illustrations of situations where these ideas have been successfully implemented.

The overall concepts presented are: 1) the flow of information is as important as the flow of product; 2) the flow of information is often more complicated than the flow of physical material, and frequently it is the sharing of information within a process that governs the process’ performance; 3) the flow of information can be modeled as the flow of physical parts, so many of the same principles that apply to the design of physical production systems can be applied to the design of information systems; and 4) the design of an information system must occur in a concurrent fashion with the development of the physical components of any manufacturing process.

## **3: Organization of Thesis**

This thesis will begin by examining traditional methods used in manufacturing process design. Some traditional flow models and techniques used to determine material flow, machine placement, and operation sequencing will be presented and critiqued. In addition, some applications of these methods will be given that demonstrate how these methods were effectively implemented.

Next, the shortcomings of traditional methods will be critiqued. The thesis will show that the nature of manufacturing has dramatically changed, mainly due to the advancements made in information technology. This improved technology has opened the door to a world where information (and its effective utilization) can be harnessed to become a sustainable competitive advantage.

A discussion of the pitfalls of not considering the information system's design at the outset of a manufacturing process design exercise will follow. The thesis will show how overall costs, system complexity, user frustration, and process rigidity were all unnecessarily increased by not considering the information system design when first designing the process.

Next, this thesis will demonstrate the need for concurrent design of manufacturing process and information systems. After reviewing the background of the rapid evolution of information technology and manufacturing process command and control software, this thesis will show how the "Power of Information" can revolutionize modern day manufacturing processes in terms of quality, cost, throughput, and resource optimization.

In the section following, it will be shown that the generation, manipulation, transportation, dissemination, and consumption of information can be modeled and treated in an almost identical manner as the flow of physical material. Once this has been demonstrated, traditional techniques used to model the physical production system will be adapted to the information system. This model's application in multiple settings will then be presented, showing the flexibility of the modeling technique.

Next, this thesis will present a framework for the concurrent design of a physical manufacturing system and an information manufacturing system. This framework will be based upon foundational design principles of both information system design and physical production design, yet will include techniques that bridge the pitfalls earlier identified that result from isolated design activities.

Once these frameworks, models, and techniques have been identified, a case illustration will be presented where the improved method was applied. This case, detailing the development of the manufacturing system for a new digital camera, provides comprehensible and concrete illustrations of a situation where these ideas have been successfully implemented.

Thus, the models, techniques, and frameworks presented in this thesis will result in a concrete package that can be used to concurrently design a physical manufacturing system and an information manufacturing system.

#### **4: Literature Review**

The thesis has drawn upon a number of research materials from recognized subject matter experts. While an effort was made to include significant detail in this project, the interested reader should refer to the following sources to develop a greater understanding.

The literature used in this project can be categorized into five major areas: facility layout design, lean production, process reengineering, information systems, and concurrent engineering. In addition, several other reference sources on general manufacturing engineering were reviewed.

#### Facility Layout Design

Facility Layout and process design can be traced back to the Industrial Revolution, where the designs of early processes were optimized. The practice of layout design was formalized by Muther (42), refined by Francis and White (22), and soon became part of standard Industrial Engineering materials, such as Maynard's handbook (40) and other foundational materials used to train process engineers (43).

#### Lean Production

Numerous texts and journal articles about the Toyota Production System and Lean Production have been published. Specifically, this thesis reviewed materials recognized as the fundamental sources of Lean Production thinking. These include Ohno's work on the Toyota Production System (47), Womack's texts on Lean Manufacturing (58, 59), Dertouzos', Lester's, and Solow's text (11), as well as Goldratt's material (24).

#### Process Reengineering

Much of the material pertaining to process simplification, streamlining and redesign was drawn from Hammer's work on process reengineering. Recognized as one of the originators of the modern process reengineering movement, Hammer's materials (28), (29), and (30) provide background on the need for process reengineering, present a procedure for reengineering, and describes numerous cases which show the profound benefits that process reengineering can bring.

#### Information Systems

Tremendous volumes of material on the design and use of information systems in a manufacturing setting have been published. The depth of material in this field demonstrates how quickly this area is expanding and advancing. Rather than selecting materials tied to one direct technology, this thesis focused on references that describe the overall issues at hand, and general architectures that are used to develop an efficient system. Such materials include texts by Satori (52) and Chorafas (5).

In addition, proceedings from numerous technical symposiums were reviewed, which gave the overall state of the industry. These proceedings included those by Brown, Mas, and Hlodversson (2), Compton (8), Flatau (20), Goossenaerts, Kimura, and Hans Wortmann (25), Goossenaerts (26), Lastra, Encarnação, and Requicha (36), Robson, Ryan, and Wilcock (50), and Rix and Schlechtendahl (51).

While much of the technology described in the above materials is now obsolete, the underlying principles and considerations contained within (especially pertaining to system architecture design) are still very much applicable.

### Concurrent Engineering

Concurrent Engineering originated with the material published by Nevins and Whitney (44) and enhanced by Hartley (32). Since then, Concurrent Engineering has evolved into other forms such as Integrated Product and Process Development, as described by Shunk (57). In addition, Fine (19) expands Concurrent Engineering to examine how its can be used in the design of supply chains as well as products and processes. Because of the benefits that Concurrent Engineering provides, its use has been incorporated into standard product design processes, such as that used by Eppinger (18) and Compton (8).

## **Part II**

---

### **Traditional Methods Used for Manufacturing Process Design**



In any given manufacturing firm, at any given time, there is likely a production process being designed. In fact, due to the rapidly shortening of most products' lifecycles, it could be stated that all processes are always in a state of design. Process teams are continually acting to implement improvements to the production system, launch the next product, or introduce of the next iteration of advanced process technology. The list of reasons to change a process' design is long, and includes such diverse motives as:<sup>13</sup>

- A change in the design of a product
- The addition or deletion of a product from a company's product line
- A significant increase or decrease in the demand for a product
- A change in the manufacturing methods used to produce a product
- The replacement of one or more pieces of process equipment
- The adoption of new safety standards
- A change in the organizational alignment of a company
- A decision to build or expand a production facility
- A need to alleviate crowded working conditions
- The desire to improve the housekeeping or appearance of a production area
- A change in the storage space required for a product
- A change to the flow of material through a process
- The need to overcome gradual changes in the existing process that have appeared over time (bottlenecks, delays, idle time, backtracking, failure to meet schedules, high ratio of handling time to production time, etc.)

Often the exact purpose, scale, scope, and timeframe involved with a particular design effort are different from all other projects ever undertaken by a firm. Indeed, in the vast majority of cases, the process design projects are completely unique. Therefore, each project brings new challenges.<sup>14</sup>

Due to the lack of similarity between process design projects, some may assume that it is impossible to develop an overall design method applicable to each and every situation. And, even if a formal design approach did exist, it would likely be so generic and abstract that it would be of little tangible use to a process design team.

However, a design method has indeed been developed and has been successfully applied to thousands of process design projects.<sup>15</sup> This design approach allows any process architect to follow a structured, clear, and straightforward path through the steps required to develop an efficient process design that meets all requirements. This method assists the process design team, allowing it to take advantage of a logical progression of design steps that will ultimately lead towards the team's goal.

---

<sup>13</sup> Facility Layout and Location: An Analytical Approach, Richard L. Francis and John A. White, Prentice-Hall, Inc., Englewood Cliffs, New Jersey, USA, 1974, Page 32.

<sup>14</sup> Systematic Planning Of Industrial Activities (SPIF) – Volume I, Richard Muther and Lee Hales, Management & Industrial Research Publications, Kansas City, Missouri, USA, 1979, Page 7-5.

<sup>15</sup> Ibid.

In this section, this design technique will be reviewed in detail. In addition, several key process steps that are not included in the original methodology will be discussed. These additional steps have developed over time, and when combined with the original approach, they create a thorough process design methodology that meets the needs of process architects.

## **5: The Systematic Layout Planning (SLP) Design Process**

The Systematic Layout Planning (SLP)<sup>16</sup> Design Process, originally developed by Richard Muther in 1965, is commonly used as the foundation of all manufacturing process design methods. This multi-step process repeatedly demonstrates its applicability to a wide number of process design projects, whether they are the design of a fully automated production facility, or the design of a flexible manufacturing job shop facility. This “organized, universally applicable approach”<sup>17</sup> is equally applied to process design projects in newly constructed facilities, or process redesign efforts in well-established facilities, and can be applied in the same way to minor as to major process design efforts.

The key objectives for the Systematic Layout Planning process include designing and determining the basic flow patterns of parts and material through the process, the identification of the size of each process element and the relationships each element shares with others in the process. In addition, SLP seeks to specify both the conceptual and the detailed design aspects of the configuration, orientation, and placement of each piece of process machinery, equipment, and support infrastructure.

To accomplish these objectives, the SLP process consists of 13 major elements, arranged in a largely sequential manner. A graphical representation of the design methodology is shown in Figure 1. Each step in the SLP process will be briefly described to show how the process is applied to a project.

### **Step 1: Gathering Key Inputs (P, Q, R, S, and T)**

The first fundamental process step consists of the gathering of key process inputs, conveniently grouped into 5 alphabetical designations (P, Q, R, S, and T).

Gathering the “P” inputs involves identifying those Products that will be manufactured using the process under design. The list of products identified includes current and future versions of those products, as well as all forms that are similar and might use the same manufacturing processes. These product families “will have variations from product to product such as different model configurations but

---

<sup>16</sup> Facility Layout and Location: An Analytical Approach, Richard L. Francis and John A. White, Prentice-Hall, Inc., Englewood Cliffs, New Jersey, USA, 1974, Page 35.

<sup>17</sup> Systematic Planning Of Industrial Activities (SPIF) – Volume I, Richard Muther and Lee Hales, Management & Industrial Research Publications, Kansas City, Missouri, USA, 1979, Page 7-1.



they generally have the same base model.”<sup>18</sup> In addition, the team identifies other product inputs (raw materials, components, and subassemblies) that are required in producing the identified products.

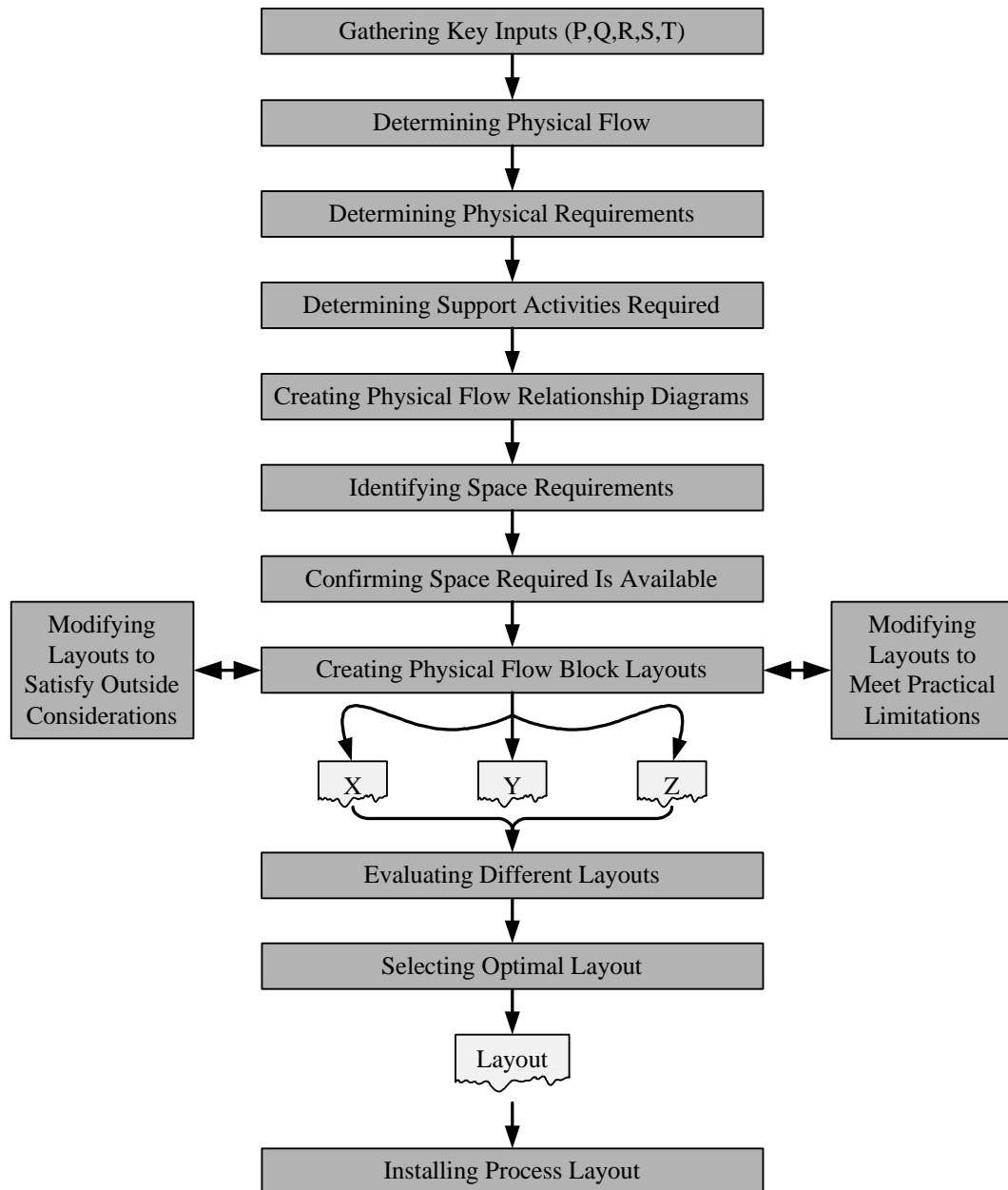

**Figure 1: The Systematic Layout Planning (SLP) Process<sup>19</sup>**

<sup>18</sup> “How To Design The Best Layout For Your Factory”, Queensland Manufacturing Institute Ltd. Newsletter, September 2001, <http://www.qmi.asn.au>.

<sup>19</sup> Systematic Planning Of Industrial Activities (SPIF) – Volume I, Richard Muther and Lee Hales, Management & Industrial Research Publications, Kansas City, Missouri, USA, 1979, Page 7-3.

Gathering the “Q” inputs consists of predicting the Quantity of parts that will be produced with the process, including the breakdown of each product variation that could be produced. The design team bases quantity levels by considering current demand level as well as demand forecasts. The design team also identifies the magnitude of uncertainty that is associated with each volume production.

Gathering the “R” inputs involves specifying how the materials will be Routed through the process, in terms of which process operations are required to make the product. Designers discover what the sequence of operations must be, and which equipment must be involved in production.

Next, identifying the “S” inputs consists of specifying the Staffing services required to assist in the production of the product, including equipment operators and supervisors.

Finally, gathering the “T” inputs consists of identifying Time considerations, such as required cycle times, shipment and delivery frequencies, as well as external seasonality issues that may affect production.

For all key inputs, the design team clearly states the desired levels of performance. If available, the team also determines the current levels of performance for those key aspects so objective metrics can be set that will allow specific monitoring of the improvements made to the process.

By completely gathering the key inputs, as well as establishing metrics for important performance characteristics, the process design team gathers most of the information that will be required in the subsequent steps of the SLP process.

## **Step 2: Determining Physical Flow**

The team continues by reviewing the physical flow of materials through the process. This step involves documenting the amount of each product type that must flow over a process route. In step 1, the team discovered many details about the product, including which components and raw materials are used to create the product, as well as what processes are required to manufacture each component of the final product. Using this knowledge, the design team can decompose the final product and can determine the necessary sequence of operations needed in the manufacturing system.

Once the sequence of operations is determined, and the required process steps are known, the design team constructs the **Physical Flow Chart**, the first of three key foundational elements used in manufacturing system design. While the Physical Flow Chart will be described in detail later in this thesis, the Chart can be briefly described as a high-level “graphical representation of the sequence of all operations, transportations, inspections, delays, and storages occurring during a process or procedure. It

includes information considered desirable for analysis, such as time required and distance moved.”<sup>20</sup> In addition, the Chart shows “the points at which materials are introduced into the process, and of the sequence of inspections and all operations except those involved in material handling.”<sup>21</sup> Constructing the Physical Flow Chart allows the design team to comprehend all of the steps and the sequence of those steps required to transform raw materials into end products.

Often, there are different sequences of operations that can be developed that will allow for the production of the end product. In addition, there are different process technologies and types of process equipment that can be used to create the desired product attributes. The design team evaluates each of these sequences and technologies and selects only those sequences that are feasible. These different sequences will then be rigorously evaluated and compared at later stages in the process.

Once the physical elements required to manufacture the desired product are identified, the team now investigates the physical requirements that will be required to meet production demands.

### **Step 3: Determining Physical Requirements**

In this step, designers take the required volume demands, as well as the production capacities of the pieces of specified equipment and determine the number of each process element that will be needed to meet the required volumes.<sup>22</sup> The team then uses the number of required pieces of production equipment to estimate the number of operators and support staff that will be required.

In completing this step in the design process, the team obtains a detailed listing of the numbers of each type of process equipment needed, as well as the number of equipment operators needed.

### **Step 4: Determining Support Activities Required**

The team then proceeds to the fourth step of the SLP process, which involves the identification of external supporting activities (such as maintenance, material handling, logistics, labor relations, housekeeping, and quality control) that will interact and assist the process. The design team must identify these external activities at this point, since it is vital that all parties that have a stake in the ultimate configuration of the manufacturing process are considered early and throughout its design.

### **Step 5: Creating Physical Flow Relationship Charts**

---

<sup>20</sup> Industrial Engineering Handbook, 2<sup>nd</sup> Edition. H.B. Maynard, McGraw Hill Book Company, Inc., New York, 1963, Page 2-25.

<sup>21</sup> Ibid, Page 2-21.

<sup>22</sup> In addition, the team should identify the uncertainty in each forecast. This will permit the team to ensure that the process is capable of meeting larger-than-expected production levels, should they occur, while at the same time ensure that the guaranteed excess capacity is not unreasonably high. While it may be simpler for the team to base the design of the new process on current production levels, the design team should ensure that they still consider the future production levels for the current product, as well as the production volume for product versions that may be may down the road.

The design team proceeds with the next step of the SLP process, which involves the creation of the **Physical Flow Relationship Chart**, the second of three key foundational elements in manufacturing system design.

The Physical Flow Relationship Chart (described in more detail later in this thesis) allows the design team to recognize the underlying relationships between different process elements and is “a graphical means of representing the desirability of locating pairs of operations near each other.”<sup>23</sup> By understanding and categorizing these relationships, the design team can identify the optimally sequenced process flow, locate process elements close together that need to be linked, and separate those process elements that need to be kept apart.

### **Step 6: Identifying Physical Space Requirements**

This step involves the analysis of space requirements needed by the process being designed. Drawing on the list of necessary pieces of equipment and operators needed to staff that equipment, the design team calculates the amount of overall floor space that will be required by the process equipment, the operators, and the space that will be needed for other areas such as material storage, maintenance access, and areas for work team meetings, and break areas.

In determining these space requirements, the team considers the possibility of future expansion and change. The layout must be flexible enough to accommodate changes in product, process, and schedule design.<sup>24</sup> By ensuring that the layout is flexible, the need to make major changes in the future decreases. Therefore, the design team often intentionally overestimates the required physical area, in order to ensure there is adequate room for future expansion.

### **Step 7: Confirming Space Required Is Available**

Once the space requirements have been calculated, the design team compares this amount to the space that has been allocated in the production facility. For a given process, if more space is required than is available, the design team searches for a new location in which to place the process. If no new locations can be found (and the space required by that process cannot be reduced), the design team must abandon the current design concept and investigate whether another process design will fit,

### **Step 8: Creating Physical Flow Block Layout Diagrams**

In this step, designers develop **Physical Flow Block Layout Diagrams**, the third key foundational element in manufacturing system design. In these Diagrams (that will be described in more

---

<sup>23</sup> Production And Operations Analysis (4<sup>th</sup> Edition), Steven Nahmias, McGraw-Hill/Irwin, New York, New York, USA, 2001, Page 560.

<sup>24</sup> Facility Layout and Location: An Analytical Approach, Richard L. Francis and John A. White, Prentice-Hall, Inc., Englewood Cliffs, New Jersey, USA, 1974, Page 71.

detail later in this thesis), the process equipment is laid out conceptually in the allocated floor space. Multiple configurations and orientations of each process are generated for further analysis. Each Diagram allows the design team to graphically visualize different process design concepts, review material and part flows, and identify how and external areas will be affected by a specific design.

### **Step 9: Modifying Layouts To Satisfy Outside Considerations**

The team now modifies the proposed designs to account for a variety of considerations. For example, one issue could be the need to access a certain location on a specific piece of equipment for maintenance purposes. Another consideration could be the need to separate different process elements due to the limited supply of utilities in a given area. Or, the presence of building constraints (such as support columns) that were not previously identified could require the modification of a process layout. This step is highly iterative, as the concepts are continually updated to reflect changes required by new considerations.

### **Step 10: Modifying Layouts To Meet Practical Limitations**

This step, also highly iterative, modifies the process layouts to account for any practical limitations. The design team considers the many impacts that each proposed plan will have on the overall system. These impacts can range from the high cost of moving a specific piece of equipment, to the need for larger aisles to account for the changing of tooling, to the requirement for fewer operators per square foot in order to satisfy safety regulations. In addition, this step should consider the impacts to other areas of the firm, such as the need to shut off electricity during process installation.

Steps 8, 9, and 10 are all iterative, and during these cycles, each process layout is repeatedly modified to ensure all factors have been accounted for.

### **Step 11: Evaluating Different Layouts**

The design team now has one or more process layouts that have been significantly modified from their initial design concepts. In this process step, the design team briefly revisits the conclusions made at each prior step. The team ensures that any modifications made to the process design during the later stages of the process have not violated any earlier design constraints. The team also recalculates the space requirements of the process to ensure that the design can still be placed in the allocated area.

### **Step 12: Selecting the Optimal Layout**

In this step, the different layouts are compared and judged against specified criteria to identify which design best meets the requirements. To accomplish this, the design team first develops criteria on

which to judge the attractiveness of each design. Then, using concept scoring<sup>25</sup>, the design team assigns weights to various evaluation criteria, according to those factors that are the most important. Such factors can include (but are not limited to) those shown in Table 1.

<ul style="list-style-type: none"> <li>• Ease of future expansion</li> <li>• Effectiveness of material-handling</li> <li>• Utilization of process equipment</li> <li>• Ease of supervision and control</li> <li>• Investment or capital required</li> </ul>	<ul style="list-style-type: none"> <li>• Flexibility of layout</li> <li>• Utilization of overall floor space</li> <li>• Fit with company organization structure</li> <li>• Meeting of future capacity requirements</li> <li>• Savings, payout, return, profitability</li> </ul>
---	---

**Table 1: Potential Factors For Use In Concept Scoring**

Each design is scored on a numerical scale on how well it meets the criteria, relative to the other concepts. These ratings are then multiplied by the weights and summed to achieve an overall utility for the design. The design team either selects the concept with the highest rating, or investigates whether two or more designs that each scored well can be combined to achieve one that is even superior.<sup>26</sup>

### **Step 13: Installing Process Layout**

Having selected a process design that meets all requirements and does not violate any design constraints, the team then moves to implement the design. The design team has at this point completed its mission and can be confident that the installed process will yield substantial improvements over the previous process.

### **Summary of the SLP Process**

At the conclusion of the Systematic Layout Planning process, the design team will have accomplished a number of objectives. First, the stated goals of the SLP process (1. the design and determination of the basic flow pattern of parts and material through the process; 2. the identification of the size of each process element and the relationships each element shares with others in the process; and 3. the configuration, orientation, and placement of each piece of process machinery, equipment, and support infrastructure) will all have been achieved. In addition, by considering the needs of multiple stakeholders in the design process, from the initial stage of gathering key process inputs through the final evaluation of a layout design, the selected design will garner the support of all necessary parties, and all constituents will have cooperated to obtain the solution. Finally, by creating the Physical Flow Chart, the Physical Flow Relationship Chart, and the Physical Flow Block Layout Diagram, the path taken to develop the design will have become carefully documented and can assist in further process improvement efforts.

---

<sup>25</sup> Industrial Engineering Handbook, 2<sup>nd</sup> Edition. H.B. Maynard, McGraw Hill Book Company, Inc., New York, 1963, Pages 8.36-8.65

<sup>26</sup> Facility Layout and Location: An Analytical Approach, Richard L. Francis and John A. White, Prentice-Hall, Inc., Englewood Cliffs, New Jersey, USA, 1974, Pages 12-14.

In summary, the SLP Process provides a process design team with a robust design methodology that is extremely flexible to multiple situations. The SLP process provides “a framework, a pattern, and a set of conventions which can be used on any layout-planning project without imposing constraints or restrictions on the handling of data or on the individual requirements of each discrete layout project.”<sup>27</sup> Its plain logic and straightforward manner, combined with its simplicity and highly segmented sequence, continue to make the Systematic Layout Planning process the primary design methodology used by manufacturing process architects.

## **6: Adding More to the SLP Process**

While the SLP process is extremely flexible and can be adapted to numerous situations and process design projects, its formal definition does not include several significant activities that are actually performed in several design exercises. By formally expanding the SLP process to include these vital process steps, a comprehensive design methodology can be developed that better describes all of the crucial steps that are traditionally involved in most manufacturing process design projects.

### **Additional Step 1: Formulating the Problem**

In many complicated manufacturing systems, it is often difficult to locate the true cause of the observable symptoms. This is especially valid for production systems, because the overall performance of the system is dependent upon hundreds of factors, usually including the complex interactions of several of those factors.

Because of this complexity, many process design projects, especially process redesigns, do not yield dramatic performance gains. A reason for this is the failure of the designers to properly formulate the key problem facing the team.<sup>28</sup> Teams become biased by only considering the current elements, flow, and products involved with the existing process design. As a result, thinking remains bound to the existing process, therefore the team only discovers and implements incremental improvements.<sup>29</sup>

To overcome this, the initial framing and clarifying of the issue at hand must be the first major step of any systematic problem solving method. The problem solving team must examine each observable symptom and, through a series of investigative and diagnostic processes, determine the underlying root cause of those symptoms. The team must focus on the “outcome of work, rather than on work as an end in itself...[and must] see itself and its work from the perspective of the customer, rather

---

<sup>27</sup> Systematic Planning Of Industrial Activities (SPIF) – Volume I, Richard Muther and Lee Hales, Management & Industrial Research Publications, Kansas City, Missouri, USA, 1979, Page 7-5.

<sup>28</sup> Facility Layout and Location: An Analytical Approach, Richard L. Francis and John A. White, Prentice-Hall, Inc., Englewood Cliffs, New Jersey, USA, 1974, Pages 10-11.

<sup>29</sup> *Ibid*, Page 20.

than from its own.”<sup>30</sup> The true cause is then formulated as a problem statement challenge, and the team then forms and develops a series of solution concepts that address and attack this problem.

Once this problem has been properly formulated, the team has a much higher probability of solving the true issue. However, if the problem formulation step is not performed, the team often spends significant time and effort treating the apparent symptoms, rather than correcting the actual cause and preventing recurrence.

As more information is gathered at each step in the design process, the team should revise the current problem formulation, thereby ensuring that the solutions being developed are addressing the true issue, not just treating deficiencies in the current design. In this manner, the team should eventually locate the underlying problem in the system, even though the path taken to find that cause was not direct.

While the repeated examination of the underlying problem may appear to lengthen the design process, these iterations make certain that the solution ultimately developed and implemented by the team will result in process design improvements that will benefit the entire production system, rather than overcome minor symptoms.

### **Additional Step 2: Broadening the Scope of the Problem**

In designing a process, more substantial performance gains can be achieved if the team consciously broadens the scope of the problem statement facing the team. This requires the team to take a “black box” design approach to specify the issue at hand. Using this approach, the team ignores the current design of the process, and only considers the problem as the need to turn a given set of inputs into a required set of outputs. The exact process elements remain unknown and unspecified during this problem formulation stage. The team carefully details the characteristics of the problem, while ensuring that any possible approaches to solve the issue are framed as broadly as possible.<sup>31</sup> Any existing biases and assumptions regarding the product, or process, are actively challenged, so the team may discover the key requirements of the problem. The design team delays any charts, diagrams, or layouts until later stages, and instead focuses on the formulation and the analysis of the problem. This frees the design team from the “tired ideas, irrelevant methods, and obsolete systems”<sup>32</sup> that have been used in the past and enables the team (during the later layout design stages) to explore as many possibilities as time constraints and organizational boundaries permit.

---

<sup>30</sup> The Agenda: What Every Business Must Do To Dominate The Decade, Michael Hammer, Crown Business, New York, New York, USA, 2001, Page 62.

<sup>31</sup> Facility Layout and Location: An Analytical Approach, Richard L. Francis and John A. White, Prentice-Hall, Inc., Englewood Cliffs, New Jersey, USA, 1974, Pages 11-12.

<sup>32</sup> The Agenda: What Every Business Must Do To Dominate The Decade, Michael Hammer, Crown Business, New York, New York, USA, 2001, Page 52.



For example, rather than specifying the design problem as the “need to locate lathe XYZ somewhere between end mill ABC and welding station DEF”, the team should identify the underlying issue as the “need to satisfy a given customer’s order for a specific project.” The reason for this is that the design of the product to be produced may have changed so much from the current version that a lathe, an end mill and a welding station may not be the best process elements to use to make the product. Expanding the scope permits the team to select a concept from an expanded possible solution space, increasing the chances of finding a solution that achieves the desired improvement levels.

The broadening of the problem scope has become a vital part of the manufacturing system design process. As process designs become more advanced and complex, there must be increased dedication towards maintaining a clearly articulated problem statement yet ensure the team is free to consider fresh approaches to the problem.

### **Additional Step 3: Brainstorming Concepts**

Once the problem has been formulated in a broader manner, the number of possible design concepts increases dramatically.<sup>33</sup> Designers are now freed from only considering incremental improvements to the current process, and can explore creative solutions to the underlying problem.

Therefore, by actively brainstorming to identify concepts that can solve the broad formulated problem, the design team is much more likely to discover a dramatic concept, that elegantly solves the required problem in a novel, yet simple manner.

### **Additional Step 4: Screening Design Concepts**

Following the brainstorming exercise, the design team typically needs to perform an initial screening of process concepts. During the brainstorming step, the design team identified a large number of concepts, likely including many concepts that take an unconventional approach to the problem. As a result, it is likely that the several of the concepts will not be feasible at the current time.

Using a pre-specified evaluation method, the team reduces the number of concepts to a small number of promising concepts. However, in screening these concepts, the design team resists the temptation to select only those concepts that resemble the current process. To achieve dramatic results, the team is seeking concepts that will simplify the overall process, even if they are completely different from the existing process.

### **Additional Step 5: Improving and Simplifying the Process Design**

Once the flow of materials and the support activities for the process have been identified, the design team reviews each of these areas to identify further areas for process improvement and

---

<sup>33</sup> Ibid, Pages 12-14.

simplification. The team looks for opportunities to eliminate unnecessary steps, streamline necessary operations, and to reorder the sequence of workflow to reduce processing time or effort. It is vital to conduct this review at this stage, rather than after the layout has been optimized, because “you don’t want to invest in an optimized layout of a sub-optimal process. That is akin to automating a process that is altogether unnecessary.”<sup>34</sup> By improving the design concepts at this early stage, designers ensure that any inefficient practices that plague the existing concepts do not continue forward and become solidified during later stages of the process.

Although the improvement and simplification tasks are first performed at this stage, they are actually performed at each subsequent stage of the design process. This is to address the added complexity that arises as different relationships are discovered and as the process layout is determined. Through repeatedly simplifying and improving the concept, much of the unneeded complexity can be removed. It is only through these activities that the team ensures the ultimate complexity of the production system will be minimized, enabling better production performance.

In essence, the step of improving and simplifying a process design involves the core activities of process reengineering. Process reengineering is “the fundamental rethinking and radical redesign of business processes to achieve dramatic improvements in critical, contemporary measures of performance, such as cost, quality, service, and speed.”<sup>35</sup> “It ignores what is and concentrates on what should be.”<sup>36</sup> Overall, it tosses away an existing work design and reinvents processes that are better suited to the current business environment. Process reengineering experts emphasize that firms must examine all of their business processes, and ask the following vital questions:<sup>37, 38</sup>

- What does this process step do?
- What is this process step’s purpose?
- How does this process step create value for customers?
- Is this process step even necessary?
- Has the simplification exercise been conducted to such an extent that a value-added process has truly been identified?
- Is the flow through this process step streamlined?
- Is the automated system justified?
- Is this process step simplified so automation can be achieved at its simplest level?

---

<sup>34</sup> “How To Design The Best Layout For Your Factory”, Queensland Manufacturing Institute Ltd. Newsletter, September 2001, <http://www.qmi.asn.au>.

<sup>35</sup> Reengineering The Corporation: A Manifesto For Business Revolution, Michael Hammer and James Champy, HarperCollins Publishers, Inc., New York, New York, USA, 1994, Page 33.

<sup>36</sup> *Ibid*, Page 33.

<sup>37</sup> Integrated Process Design and Development, Dan L. Shunk, Business One Irwin, Homewood, Illinois, USA 1992, Page 64.

<sup>38</sup> The Agenda: What Every Business Must Do To Dominate The Decade, Michael Hammer, Crown Business, New York, New York, USA, 2001, Page 64.

- What measures are used to judge the performance of this process step?
- What are the current levels of those measures?
- What other process steps interface with this one?
- What do other process steps need from this one, and what does this process step need from others?

If the answers to these questions cannot be quickly and simply expressed, the process design team should keep pushing to simplify and streamline the process design. The team should look for opportunities to consolidate neighboring process steps, or eliminate process steps altogether, while still maintaining or improving the overall simplicity of the process. Often, process elements persist in a process long after the need for them has disappeared. Product, technological, or staffing changes all contribute to make some process elements obsolete, even though they have never been removed from the official process flow. Therefore, just by asking the simple questions, and then driving to the root foundation of underlying assumptions, the design team can frequently find valuable potential for improvement.

In many cases, after each process step has been examined using the above guidelines, dramatic savings will be achieved. Indeed, reengineering advocates express that most savings come from process simplification rather than process automation.<sup>39</sup> Actually, after simplifying operations, it is often found that so much improvement has already been made, that automation of the resulting step is not needed.<sup>40</sup>

Therefore, as process designs become more advanced, there must be increased dedication towards improving and simplifying each and every aspect of a process design. Each proposed concept must be repeatedly reviewed and adapted to make certain it is a logical design that does not introduce unnecessary complexity into the overall production system.

#### **Additional Step 6: Implementing Lean Production Principles**

One of the most major influences on modern production system design is the Toyota Production System developed by Taiichi Ohno. The Toyota Production System showed how the world could manufacture products more efficiently and with better quality, but would require fewer resources and lower overall costs. In addition, the Toyota Production System took an important look at how people are treated in a factory setting and showed how they can be effectively empowered to yield incredible performance improvements.<sup>41</sup> The Toyota Production System showed how to “do more and more with

---

<sup>39</sup> Integrated Process Design and Development, Dan L. Shunk, Business One Irwin, Homewood, Illinois, USA 1992, Page 69.

<sup>40</sup> Ibid, Page 64.

<sup>41</sup> Toyota Production System: Beyond Large Scale Production, Taiichi Ohno, Productivity Press, Portland Oregon, USA, 1988, Foreword.

less and less – less human effort, less equipment, less time, and less space – while coming closer and closer to providing customers with exactly what they want.”<sup>42</sup>

After years of lagging behind their Japanese competitors, Western manufacturers started to examine the competitive advantage that the Toyota Production System gives. This examination allowed firms to identify the central elements of the Toyota Production System, which would in turn allowed them to redesign their own processes and close the competitive gap.

Labeled as “Lean Production” by Womack (et al), the incorporation of the Toyota Production System’s manufacturing fundamentals resulted in numerous benefits.<sup>43</sup> In many successful implementations of lean manufacturing, labor productivity typically doubles all the way through the system. In addition, production throughput times and inventory levels are slashed by 90 percent. Errors reaching the customer are typically cut in half, as are job-related injuries. Also, time-to-market for new products is cut in half, allowing a wider variety of products to be offered to customers at very modest additional cost. In addition, capital investment and physical resources required are greatly reduced.<sup>44</sup> After initially designing a manufacturing process using lean production fundamentals, firms can continue to reap additional benefits through the use of continuous improvement activities. These improvements, “can typically double productivity again through incremental improvements within two to three years and halve again inventories, errors, and lead times during this period.”<sup>45</sup>

While there are numerous sources detailing the Toyota Production System and Lean Production Fundamentals, a detailed analysis of Lean Production will not be presented here. Interested readers should refer to Ohno<sup>46</sup>, Womack<sup>47</sup>, and Womack<sup>48</sup>.

Simply, the Toyota Production System focuses upon the consistent and thorough elimination of all sources of waste. Waste can be described as any human activity that absorbs resources but creates no value. The key categories of waste include:<sup>49</sup>

- Overproduction (Production of items no one wants so that inventories and remaindered goods pile up)

---

<sup>42</sup> Lean Thinking: Banish Waster and Create Wealth In Your Corporation, James P. Womack and Daniel T. Jones, Simon & Schuster Publishers, New York, New York, USA, 1996, Page 15.

<sup>43</sup> Ibid, Page 15.

<sup>44</sup> Ibid, Page 27.

<sup>45</sup> Ibid, Page 27.

<sup>46</sup> Toyota Production System: Beyond Large Scale Production, Taiichi Ohno, Productivity Press, Portland Oregon, USA, 1988.

<sup>47</sup> The Machine That Changed the World: The Story of Lean Production, James P. Womack, Daniel Jones, Daniel Roos, HarperCollins Publishers, New York, New York, USA, 1991.

<sup>48</sup> Lean Thinking: Banish Waster and Create Wealth In Your Corporation, James P. Womack and Daniel T. Jones, Simon & Schuster Publishers, New York, New York, USA, 1996.

<sup>49</sup> Ibid, Page 15.

- Inventories
- Moving
- Making Defective Parts and Products
- Over-processing (Processing steps which aren't actually needed)
- Transporting (Movement of employees and transport of goods from one place to another without any purpose)
- Waiting (Groups of people in a downstream activity standing around waiting because an upstream activity has not delivered on time)

To drive out waste, designers use a series of tools, such as Kanban (signaling tools to manage and assure just-in-time production), Heijunka (the averaging-out of production rates in terms of quantities of each specific product), Dokika (the synchronizing of production rates across all process elements to avoid any processes going too fast), Jidoka (the freeing-up of operators' hands to perform other tasks during a processing operation), Poke-Yoke (the incorporation of mechanisms into equipment design that will stop equipment at the occurrence of an abnormality), and Visual Control (the implementation of signaling devices that make the current state of a process, including any performance abnormalities, continuously visible to all parties).

In addition, other key fundamentals of the Toyota Production System and Lean Manufacturing include:<sup>50</sup>

- Facilitate standard operation
- Achieve work flow without waste
- Minimize amount of manpower required
- Implement quality control systems at every operation
- Ensure ease of equipment maintenance
- Ensure operator, part and equipment safety
- Minimize utilities' use

Since Lean Production principles penetrate so many aspects of a manufacturing system, there is not a distinct process design step where Lean Production elements are introduced into the design. Rather these fundamentals should continually influence the design process. Specifically, lean concepts should influence actions taken at the stages for: Brainstorming Concepts, Determining Physical Flow, Identifying Physical Space Requirements, and Creating Physical Flow Block Layout Diagrams.

### **Additional Step 7: Simulating The Process**

Advances in information technology have led to sophisticated software applications that analyze process concepts. The building and use of these simulations allows the team to study a design without

---

<sup>50</sup> “Concept of Layout & Systems - Production Preparation Process (3P)”, Shingijutsu Co., Ltd. (<http://www.shingijutsu.co.jp/E.HTM/vol03.htm/cont03.htm>), Gifu, Japan, April 6, 2003.

having to move physical equipment. Through this, the team obtains further insights about the performance of different process designs.

Once a simulation has been constructed and validated using existing production data, the performance of the system can be predicted as different events occur.<sup>51</sup> For example, the ultimate output of the system can be predicted as the capacity of an in-process inventory buffer is adjusted. Simulation is extremely valuable, since it provides “a system-wide view of the effect of local changes to the manufacturing system. If a change is made at a particular workstation, its impact on the performance of this station may be predictable. On the other hand, it may be difficult, if not impossible, to determine ahead of time the impact of this change on the performance of the overall system.” As manufacturing systems become more and more complex, the need for detailed process simulation will increase further, since managers will be less and less able to comprehend the intricate behavior of the production system.

By performing the simulation numerous times, with different parameters set to various parameters, the design team can obtain valuable insight into the behavior of the system in a relatively short time. A simulation model permits designers to optimize their operational policies to use in the management system so that the manufacturing system’s performance will meet all requirements.<sup>52</sup> Some of the performance metrics used to evaluate the effectiveness of different management policies are shown in Table 2.

Management Policies	Performance Metrics to Evaluate Policy Effectiveness
<ul style="list-style-type: none"> <li>• Production scheduling policies</li> <li>• Raw-material inventory policies</li> <li>• In-process inventory policies</li> <li>• Machine Control strategies</li> <li>• Preventive Maintenance policies</li> <li>• Quality-Control policies</li> </ul>	<ul style="list-style-type: none"> <li>• Throughout</li> <li>• Time in system for parts</li> <li>• Time parts spend in queues</li> <li>• Time parts spend waiting for transport</li> <li>• Time parts in transport</li> <li>• Timeliness of deliveries</li> <li>• Sizes of in-process inventories</li> <li>• Utilization of equipment and personnel</li> <li>• Proportion of time that a machine is broken, starved, blocked, or undergoing preventive maintenance</li> <li>• Proportions of parts that are reworked or scrapped.</li> </ul>

**Table 2: Policies and Performance Metrics Used In Manufacturing Simulation<sup>53</sup>**

Simulation tools can be employed at any stage in the design process; however, they are highly beneficial at two distinct periods in the process. Using these tools at an early step (Determining Physical

<sup>51</sup> Simulation Modeling & Analysis, Second Edition, Averill M. Law and W. David Kelton, McGraw-Hill, Inc. New York, New York, USA, 1991, Page 115.

<sup>52</sup> Ibid, Page 115.

<sup>53</sup> Ibid, Page 698-699.

Requirements) allows the team to discover the proper number of operators and pieces of equipment that will be needed to meet forecasted demands. Later, at the final evaluation stage, more advanced simulations can confirm the performance predictions before a firm commitment to a given design is made.

Therefore, if possible, process design teams should conduct simulations of process design concepts under consideration. These simulations can identify underlying factors too subtle to be easily observed, as well as help the team optimally configure different aspects of the production system's design. Finally, the team can identify the required control policies that will result in the best performance of the manufacturing system.

### **Additional Step 8: Confirming Performance**

One final piece should be added to the Systematic Layout Planning design methodology. In this step, the design team monitors the behavior of the installed process.<sup>54</sup> During the design process, the team made many estimates and assumptions about the ultimate performance of the production system and many decisions were in turn made based on these assumptions. Because of this, the design team uses this step to check that the actual performance of the process is closed to the expected performance levels.

If the performance levels are less than the team hoped for, it is likely that a key assumption in the process design was based on flawed logic. To correct this situation and improve the performance of the newly implemented system, the design team acts to locate and overcome this faulty thinking.

Similarly, if the performance levels are higher than the team expected, the team investigates to determine the cause for the improved behavior, and seeks to take further advantage of this unexpected benefit.

## **7: The Traditional Manufacturing Process Design Methodology**

The Systematic Layout Planning process, long used as the benchmark methodology for manufacturing system design can be combined with the other important elements of process design. What results is represented in Figure 2, and can be treated as the traditional methodology used in manufacturing system design.

---

<sup>54</sup> Industrial Engineering Handbook, 2<sup>nd</sup> Edition. H.B. Maynard, McGraw Hill Book Company, Inc., New York, 1963, Pages 8.36-8.65.

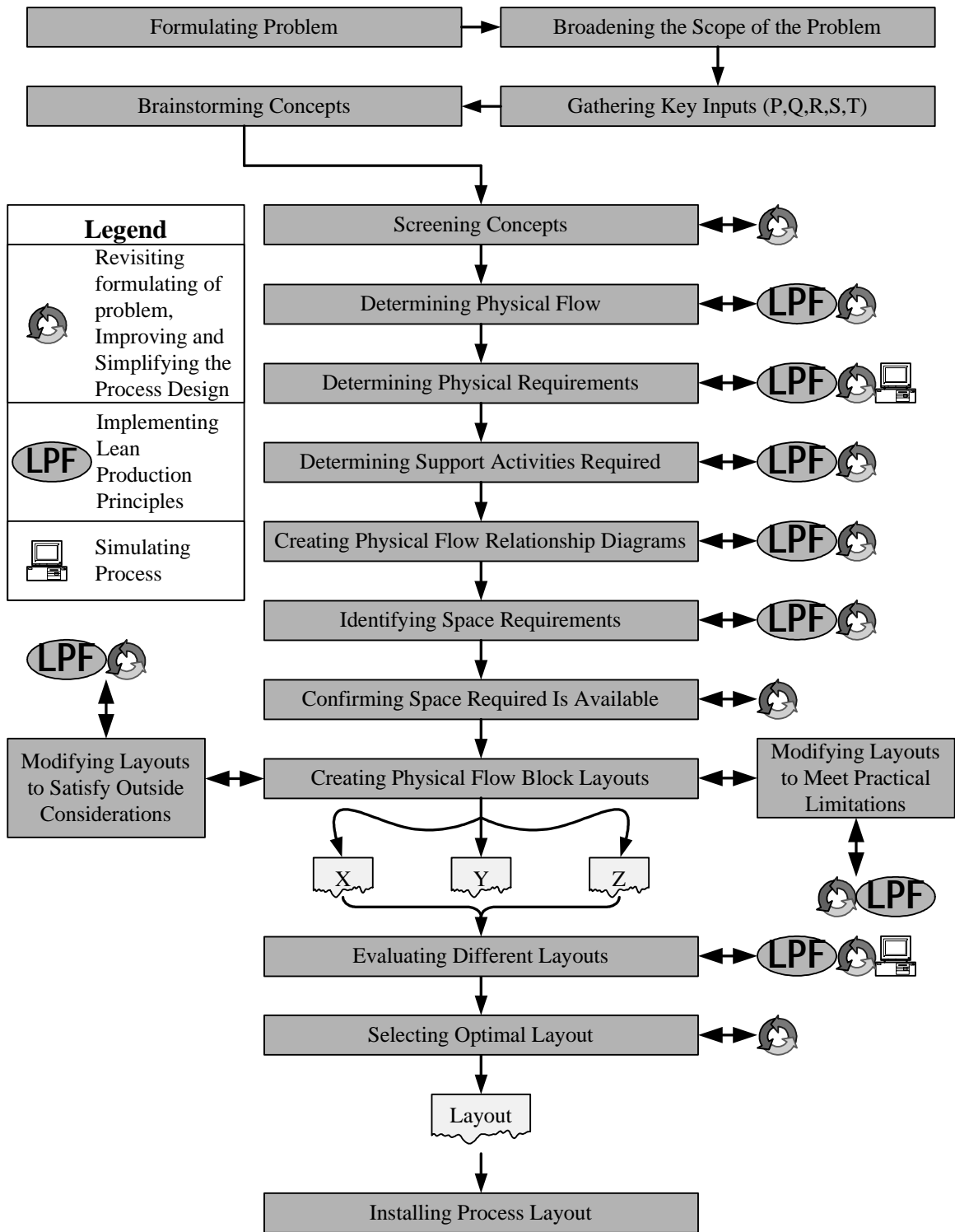

**Figure 2: The Traditional Methodology Used in the Design of Manufacturing Systems**



## 8: The Foundational Elements of the Traditional Process Design Methodology

As mentioned, there are three foundational elements of that are used in the traditional methodology, which include the Physical Flow Chart, the Physical Flow Relationship Chart, and the Physical Flow Block Layout Diagram. Each of these tools serves a vital and unique purpose in the design process. Taken together, they allow the design team to develop a comprehensive process design concept that optimally meets all process requirements while satisfying design constraints.

### A Physical Flow Chart: The First Foundational Element

The Physical Flow Chart has been a central element of manufacturing process design for decades. At its core, the Flow Chart is a high-level “graphical representation of the sequence of all operations, transportations, inspections, delays, and storages occurring during a process or procedure. It includes information considered desirable for analysis, such as time required and distance moved.”<sup>55</sup> In addition, the Physical Flow Chart shows “the points at which materials are introduced into the process, and of the sequence of inspections and all operations except those involved in material handling. It may require any other information considered desirable for analysis, such as time required and location.”<sup>56</sup> Constructing the abstract Physical Flow Chart allows the process design team to comprehend all of the steps (and the sequence of those steps) required to transform raw materials into end products. An example of a Physical Flow Chart is shown in Figure 3.

This sample Physical Flow Chart shows much more than the basic cutting, bending, drilling, welding, assembling, and painting operations involved to produce a fictional metal assembly. This is because the purpose of the Physical Flow Chart is to show all steps associated with the production of a part. Typically, steps involved in a production process are grouped into 5 classifications.<sup>57</sup> These 5 standardized actions, their associated symbols, and their descriptions include<sup>58</sup>:

- **Operation:** An operation element, shown as a circle, occurs when an object is intentionally changed in any of its physical or chemical characteristics, is assembled with or disassembled from another object, or is arranged for another operation, transportation, inspection, or storage.
- **Inspection:** An inspection element, shown as a square, occurs when an object’s characteristics are examined for identification or is verified for quality or quantity.
- **Transportation:** A transportation element, shown as a block arrow, occurs when an object is moved from one place to another.
- **Storage:** A storage process element, shown as an inverted triangle, occurs when an object is kept and protected against unauthorized removal.

---

<sup>55</sup> Ibid, Page 2-25.

<sup>56</sup> Ibid, Page 2.21.

<sup>57</sup> Ibid, Pages 2.20-2.21.

<sup>58</sup> Ibid, Page 2.21.

- **Delay:** A delay process element, shown as a rounded square, occurs when conditions do not permit or require immediate performance of the next planned action.

Using these five standard symbols, most manufacturing production processes can be fully represented. However, three additional symbols (which provide more detail of a process flow) are also commonly used. They include:

- **Deliver:** A Deliver element, shown as a pentagon, occurs when raw material is brought to the start of the process or to any other intermediate process.
- **Route:** A Route process element, shown as a diamond, occurs when material has its downstream processing plan determined by decisions made at this element. Often, the actual decision to Route a part may be part of an Operation. If it is, it should not be considered a Route process element. Rather, a Route process element involves the separate dispositioning and allocation of parts that were processed at previous Operations. The only tasks being performed at a Route process element involve the allocation of material to downstream process elements.
- **Ship:** A Ship process element, shown as a hexagon, occurs when finished product is removed from the process after all processing has been completed.

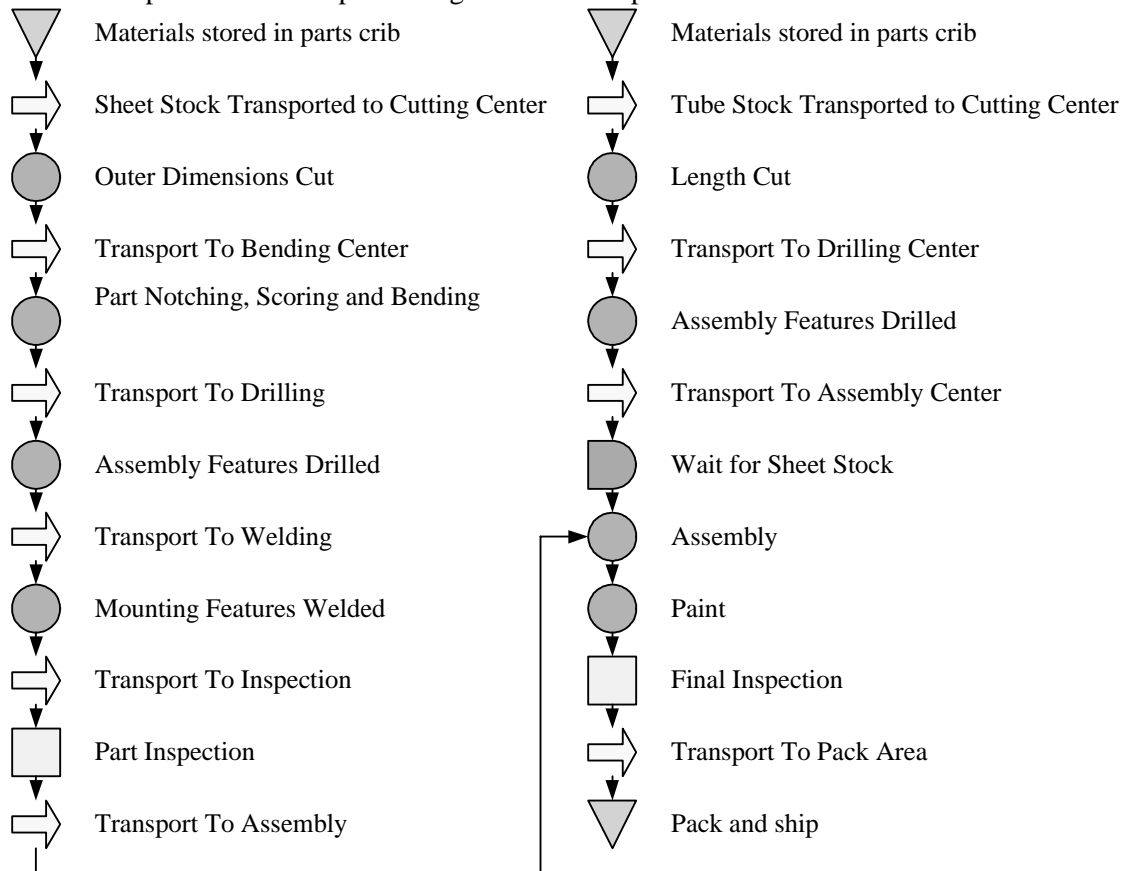

**Figure 3: A Sample Physical Flow Chart**

In addition, there are three process elements, which are sometimes present in a manufacturing system, but whose presence is not intended. These elements can have negative effects on a process'

performance. Therefore, designers should carefully study the process to determine if these elements actually exist. These elements are:

- **Accumulate:** An Accumulate element, shown as a cylinder, occurs when carefully sequenced parts are collected and mixed together so that the initial sequence is lost. For example, when parts are combined into one batch for drum polishing, the original order of those parts is lost. Although similar to a Storage process element, an Accumulate process element specifically involves the loss of part sequence.
- **Confound:** A Confound element, shown as a spiral, occurs when negative factors sufficiently influence a process element to cause the misidentification or improper processing of material. For example, a Confound element commonly occurs if a part can be passed through a process by taking any of a multiple paths, due to duplicate parallel machinery. It becomes difficult to know at the end of a process which path the part took through the process. Confound process elements usually lie downstream of Route process elements.
- **Interrupt:** An Interrupt element, shown as a star, occurs when factors external to the production system cause one or more process elements to cease their normal production. An example of an Interrupt element is the occasional need for the use of a piece of process equipment by an external process, due to demand overflow.

While these negative elements are obviously not part of the intended process design (and are often caused by factors beyond the design team's control) the awareness of the project designers to their presence provides valuable insight. The process can then be redesigned to minimize the adverse effects these elements can have.

When developing the Physical Flow Chart, it is often helpful to create an input/output diagram for each process element.<sup>59</sup> An input/output diagram can take many forms, but usually consists of a "black box" in which the tasks performed within a specific process element take place. The actual steps that occur inside the process element are ignored; only the inputs and outputs are considered. The black box is fed by multiple inputs, which could represent material, manpower, energy, equipment, information, and so on. Similarly, the black box generates multiple outputs, such as finished components, scrap, energy, information, etc. By constructing an input/output diagram for each process element, or by performing a similar decomposition analysis, the design team achieves greater clarification of the exact role of each process element as it fits into and relates to the entire production system. During this step, the design team also must consider more systematic issues, such as material handling, maintenance, and staff supervision issues. Although these elements may not be constant inputs to every process element, not accounting for these elements will surely result in a dysfunctional process.<sup>60</sup>

---

<sup>59</sup> "Perspectives on Manufacturing Engineering Software Integration", C.R. McLean, Information Infrastructure Systems For Manufacturing: Proceedings of the IFIP TC5/WG5.3/WG5.7 International Conference on the Design of Information Infrastructure Systems For Manufacturing, DIISM 1996, Jan Goossenaerts (Editor), Chapman & Hall, London, 1996, Page 23.

<sup>60</sup> Facility Layout and Location: An Analytical Approach, Richard L. Francis and John A. White, Prentice-Hall, Inc., Englewood Cliffs, New Jersey, USA, 1974, Page 72.

In reality, most processes are more complicated than can be shown on a Physical Flow Chart. Many times process elements, which are not connected sequentially, actually do pass material to each other, but do so in complex ways. Other times, process elements may share the same support resources. Other times, it is just convenient to have different process elements near each other. Although it is difficult to show these relationships on a Physical Flow Chart, they can easily be shown with a Physical Flow Relationship Chart, the second foundational element of the traditional process design methodology.

**A Physical Flow Relationship Chart: The Second Foundational Element**

The Physical Flow Relationship Chart is an extremely powerful graphical tool that is used in process design. The Physical Flow Relationship Chart, a sample of which is shown in Figure 4, allows the design team to recognize the underlying relationships between different process operations. This Chart is “a graphical means of representing the desirability of locating pairs of operations near each other.”<sup>61</sup> By understanding and categorizing these relationships, the design team can begin to develop a properly sequenced process flow, locate process elements close together that need to be linked, and separate those process elements that need to be kept apart.

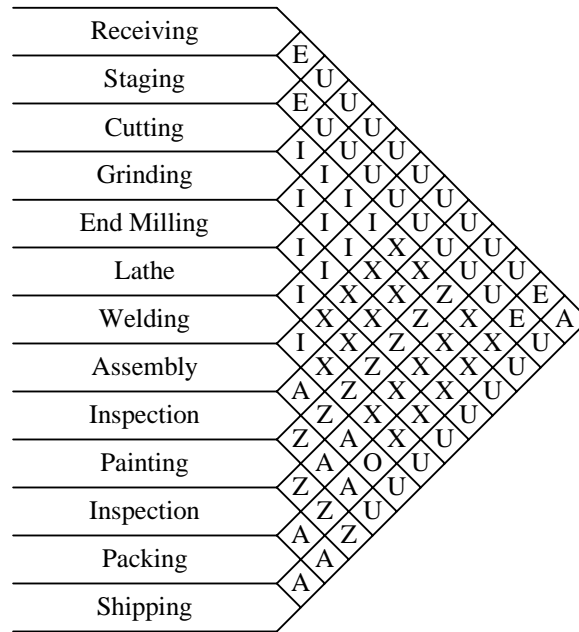

**Figure 4: A Sample Physical Flow Relationship Chart**

The left-hand side of the Physical Flow Relationship Chart lists all process elements that were included in the Physical Flow Process Chart. In addition, it should include other building constraints that may affect the process layout; such as need for a process element to be close to the centralized exhaust

---

<sup>61</sup> Production And Operations Analysis (4<sup>th</sup> Edition), Steven Nahmias, McGraw-Hill/Irwin, New York, New York, USA, 2001, Page 560.

system. The matrix on the right-hand side allows the design team to identify the relationship between the process elements. Within each square, the team assigns a score based upon the relationship between the two connected elements. These ratings are known as “Proximity Ratings.”

“A Proximity Rating is a simple weighting that reflects the desirability of physical proximity between any two work-centers. Production entities that have complicated or high volume material flow between them acquire a high Proximity Rating. Conversely, those entities that have undesirable interaction, (e.g. one process introduces contaminants into the other), have a negative Proximity Rating applied.”<sup>62</sup>

Table 3 shows a common Proximity Rating system that is used to populate Physical Flow Relationship Charts.

<b>Proximity Rating</b>	<b>Description</b>
A	<b>Absolutely necessary:</b> There is a high rate of material transfer, materials transferred are cumbersome to handle, or other reasons make the close proximity of the two process elements absolutely necessary.
E	<b>Extremely important:</b> There is a moderate rate of material transfer, materials transferred are somewhat cumbersome to handle, or other reasons make the close proximity of the two process elements extremely important.
I	<b>Important:</b> There are regular situations where it would be nice if the two process elements were close together, but proximity is not vital.
O	<b>Ordinary:</b> There are occasional situations where it would be handy if the two process elements were close together, but proximity is not vital.
U	<b>Unimportant:</b> It does not matter if the process elements are located close together or not. The entities are unrelated.
X	<b>Undesirable:</b> It would be better if the process elements could be kept separated.
Z	<b>Extremely undesirable:</b> It is dangerous if the process elements are near to each other. Or, it is likely to be highly disruptive to one or both of the process elements if they are located close together.

**Table 3: Proximity Ratings Used For Placement of Manufacturing Operations**

Remember that the Physical Flow Relationship Chart focuses on the actual physical location of process elements and discovers the relationships between process elements as physical elements move through the process. In addition, the Chart also focuses on the relationships between process elements and the support activities involved with the process. Therefore, with this Chart, the design team should consider equipment placement as well as the auxiliary process elements such as material transfer, contamination, noise, safety, and part presentation.

In the creation of a Physical Flow Relationship Chart, design teams will use many criteria to classify a process element. Often these criteria will have to be adjusted in relation to the size of the parts or the hazards involved in the process. For example, a design team will obviously place a larger

<sup>62</sup> “How To Design The Best Layout For Your Factory”, Queensland Manufacturing Institute Ltd. Newsletter, September 2001, <http://www.qmi.asn.au>.

importance on particulate contamination if they are designing a silicon wafer fabrication line than if they are designing an engine block machining line.

At times, there may not even be much variance between the ratings. If this is the case, this uniformity signifies that physical placement of process elements is not constrained. So, the elements should be placed in the optimal location to facilitate product flow. Overall, exact categorization of a specific process is not crucial, however the team should strive to utilize a set of metrics that would result in an objective analysis of each of the process steps and still provide an adequate amount of differentiation between process elements.

Note that the complexity of a Physical Flow Relationship Chart increases quite quickly and dramatically with the size of the process under consideration<sup>63</sup>. For a relatively simple process of 10 elements, 45 relationships must be evaluated. However, for a process of 20 elements, 190 must now be considered, and for a process of 50 elements, 1225 relationships exist! Because of this, the team must recognize that they should not agonize over each and every relationship. Indeed, the difference between an **Ordinary**, an **Important**, and an **Extremely Important** Rating generally will not affect the overall outcome of the design process. The team should therefore strive to identify mainly the critical relationships (**Absolutely Necessary**, **Undesirable**, and **Extremely Undesirable**), and then populate the remainder of the Chart as needed.

If the task of creating the Physical Flow Relationship Chart is too daunting, the team should first break the process under review into logical areas, such as “Machining”, “Assembly”, “Inspection”, etc. Once the overall relationships between these large areas are determined, the team should then look deeper into each area to identify those underlying relationships.

Once completed, the Physical Flow Relationship Chart may include so many relationships that it becomes hard to extract meaning from all of the information. To assist with this possibility, another process design tool can be used which is directly related to the Physical Flow Relationship Chart. This tool is the Physical Flow Relationship Diagram, an example of which is shown in Figure 5.

In the Physical Flow Relationship Diagram, each process element is represented by an equally sized square.<sup>64</sup> Lines are drawn between each element, with the line type representing the underlying relationship between two process elements. For example, in Figure 5, it is **Absolutely Necessary** to place element 10 near elements 5 and 8, **Extremely Important** to place it near element 9, and **Important** to

---

<sup>63</sup> For N process elements, there are  $N*(N-1)/2$  relationships that must be considered. Thus, for a complex process, the addition of one more process element dramatically increases the size of the Relationship Chart.

<sup>64</sup> The process elements should not be drawn in scale to their actual size. Actual spatial relationships will be examined when constructing the Physical Flow Block Layout, the third foundational element.

place it near elements 4 and 2. However, element 10 has **Unimportant** relationships with elements 1, 3, 6, and 7, and does not have any **Undesirable** or **Extremely Undesirable** relationships with any elements.

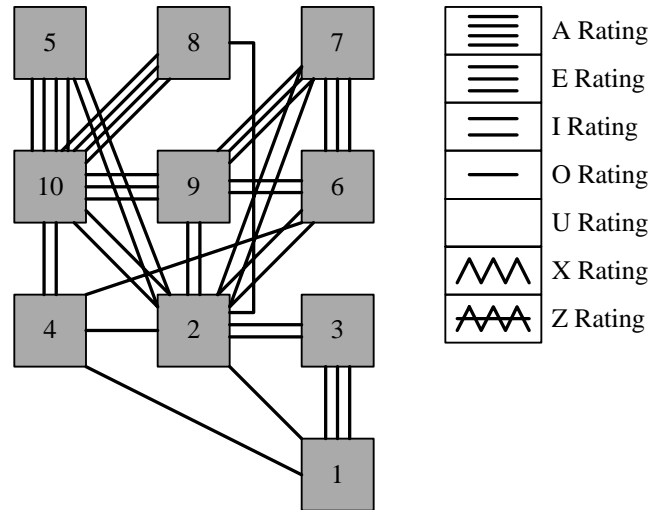

**Figure 5: A Sample Physical Flow Relationship Diagram<sup>65</sup>**

Note that it may be difficult to read the Physical Flow Relationship Diagram. However, using a drawing tool such as Microsoft<sup>®</sup> Visio<sup>®</sup> will allow the process design to move shapes around and have the relationship connections follow. Indeed, some drawing programs have macros that will optimize the layout of a Physical Flow Relationship Diagram, so that it is easier to read. Once the Physical Flow Relationship Diagram has been laid out in an optimized manner, this may provide the design team insights into how the actual pieces of equipment should be laid out in the process. However, the team must still account for the relative size of each of the process elements, so the layout of the Physical Flow Relationship Diagram may not ultimately prove to be the optimal layout for the actual process.

Once the Physical Flow Relationship Chart has been populated, the process team will discover that they are well on their way to developing the optimal design configuration. Once this stage has been reached, the team typically creates a Physical Flow Block Layout Diagram, the third foundational element of the traditional process design methodology.

### **A Physical Flow Block Layout Diagram: The Third Foundational Element**

The third major element in the development of a manufacturing process design is the Physical Flow Block Layout Diagram. This element commences the planning for the actual physical layout of process equipment. This Diagram allows the design team to graphically visualize design concepts, review material and part flows, and identify any external requirements or constraints for the process.

<sup>65</sup> Facility Layout and Location: An Analytical Approach, Richard L. Francis and John A. White, Prentice-Hall, Inc., Englewood Cliffs, New Jersey, USA, 1974, Page 58.

The team begins by assigning rough shapes to each piece of equipment, based on exterior dimensions. At this stage of the process, exact dimensions are not required, since some of the equipment may still be under development. However, the team should agree on approximate estimations for each process element, including material staging areas, operator work areas, and process inspection stations.

The team then develops the physical constraints of the factory floor space. Such constraints include overall dimensions, ingress/egress requirements, availability of required utilities, and overall safety requirements (such as sprinkler coverage, ventilation, etc.). These requirements should be captured in as much detail as possible, as a minor change in requirements will have a major impact on a process layout. Therefore, at this stage, it is usually beneficial to invite multiple external parties to join the process design team. These parties could include safety and fire inspectors, plumbing/electrical/HVAC facilities engineers, environmental engineers, and building architects.

Next, the team should consider the placement of process elements in all of the five traditional flow patterns that are shown in Figure 6. Each flow pattern has advantages and disadvantages, and each is suited for a specific application.

The **Straight Pattern** is simple and basic. Process elements are arranged in a straight line, making material transfer through the system quite clear-cut. This flow pattern is widely used in many manufacturing settings, however it does have the disadvantage that it generally requires separate receiving and shipping areas, unless finished goods are transported all the way back to the beginning of the process. Another significant disadvantage is that communication between stations along the process is difficult since messages must be passed along from station to station. At best, the messages arrive only slightly corrupted. At worst, the messages don't arrive at all and the end of the process is completely unaware of the status of upstream operations.

The **L-Shaped Pattern** is similar to the **Straight Pattern**. It is used in those locations where space constraints do not permit a completely straight line. Usually, the **L-Shaped** and the **Straight** configurations are used for automated processing lines, or where the reorientation of the material being flowed is difficult or cumbersome.

The **U-Shaped Pattern** has recently become quite popular. The system is easier to administer, since all operators can see the other stations and a greater awareness of the system's state is achieved. In addition, this design allows the same area to be used for receiving and shipping. However, this configuration sometimes make the presentation of parts to the stations more difficult, as material must be brought either into the middle of the work cell or fed through the back of a piece of equipment. While most lean manufacturing principles favor the configuration of process elements in cells by using the **U-Shaped Pattern**, the design team may find that other configurations are more effective.



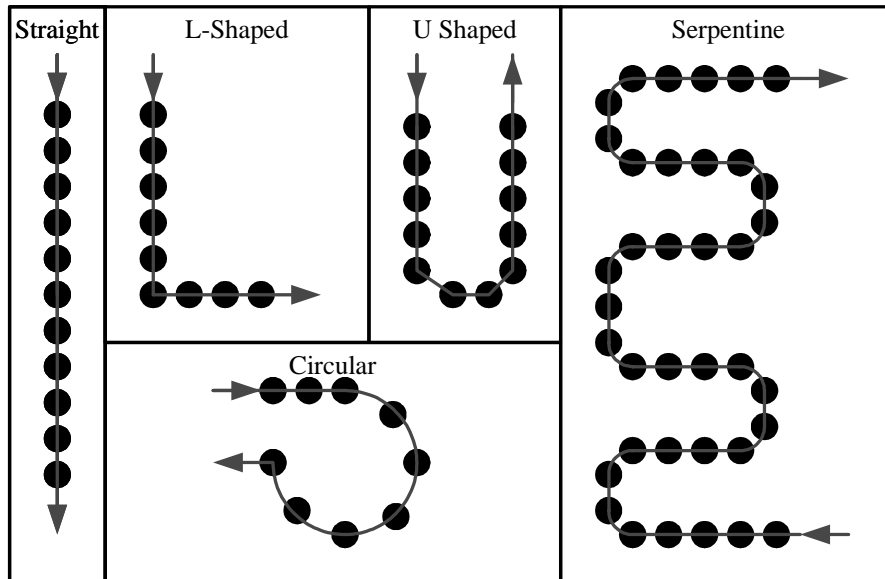

Figure 6: Traditional Flow Patterns Used In Process Layouts<sup>66</sup>

The **Circular Pattern** is often used where the termination of the process is very near the origination, or when parts need to be passed through the system more than once. A common example of this is circuit board lithography, where parts make multiple cycles through the various masking, developing, and etching stations.

Finally, the **Serpentine Pattern** is used for very long lines. It also permits the **Straight Pattern** to benefit from some of the advantages of the **U-Shaped Pattern**. However, its complexity has several disadvantages, including the fact it is often difficult for observers to understand the flow of product through the system.

In addition to these traditional five patterns, other flow patterns exist. However, these alternate flow patterns can usually be decomposed into combinations of the five traditional flow patterns.

Once flow patterns have been evaluated, the design team then develops a design that shows the relative positioning of each piece of equipment. To accomplish this, the team uses “dolls” cut from construction paper or a basic drawing program. Although these tools may seem quite juvenile, these Diagrams provide a sufficient level of detail for this stage in the design process. Physical Flow Block Layout Diagrams developed in this manner are easily modified, easily understood by multiple stakeholders, and allow multiple configurations to be compared simultaneously.

<sup>66</sup> Facility Layout and Location: An Analytical Approach, Richard L. Francis and John A. White, Prentice-Hall, Inc., Englewood Cliffs, New Jersey, USA, 1974, Page 44.

At this time, completely creative designs should be eagerly explored. Influential factors, such as the cost associated with moving a specific piece of equipment, should not be considered at this point in the process.

The development of the Physical Flow Block Layout Diagram may appear to be a daunting task, depending on the size and the complexity of the process being designed. However, the design team can attack this challenge in a systematic and structured manner. The team should start with the previously developed Physical Flow Relationship Chart and begin by placing the process elements whose proximity to another is “Absolutely necessary.” Continue until all elements that have an “A” Proximity Rating are located. The team then steps through the Relationship Chart to place the process items with “E” ratings, then with “I” ratings, and so on. If compromises to the placement of equipment must be made, the team should endeavor to reach the compromise by weighting the Proximity Ratings accordingly.

The steps involved in the development of the Physical Flow Block Layout Diagram will be highly iterative, as the design team attempts to reach a globally optimal layout that meets all the design constraints. After all, the design team is trying to best optimize multiple parameters, such as the placement of the machines, the flow of material, access to work areas, total area of the process, supply of materials, as well as several other criteria identified in the Relationship Chart.

To assist in comparing two different layout configurations, the team may wish to create a From-To Chart. This Chart, a sample of which is shown in Figure 7, is constructed by placing the distances between two process elements in the appropriate square, similar to a mileage chart constructed between multiple cities.

In addition to the process elements, the design team may wish to include other elements, such as distance to the nearest exit, fire extinguisher, break room, etc. Note that the team must also include elements involved in the material handling and maintenance of the process elements.<sup>67</sup> Once the From-To Chart has been populated, the team can enter the data into a spreadsheet program and perform an optimization by minimizing the total distance for the entire system. Such an optimization will allow the team to develop an overall utility rating and then objectively compare multiple layouts to each other. It is at this time that the team should consider other influential factors, such as the time and cost associated with moving a specific piece of equipment.

The final result of this process is the Physical Flow Block Layout Diagram. This Diagram is a rough (but in scale) layout of the process, in a space representative of the available footprint, showing the flow of material through the system. A sample of a Physical Flow Block Layout Diagram is given in

---

<sup>67</sup> Ibid, Page 72.

Figure 8.

Raw Material Storage								
Saw	16							
Lathe	40	24						
Drill	72	56	32					
Mill	88	72	48	16				
Inspection	60	44	20	36	52			
Packing	36	20	44	60	76	24		
Finished Goods Storage	20	36	60	76	92	40	16	
	Raw Material Storage	Saw	Lathe	Drill	Mill	Inspection	Packing	Finished Goods Storage

**Figure 7: From-To Chart Showing Distances Between Process Elements<sup>68</sup>**

Once the Physical Flow Block Layout Diagram has been populated, the design team will discover that they are ready to implement the process design. Before the equipment is moved into place, the team should perform a final check to ensure that all stakeholders have been included, and all aspects related to the process design have adequately been reviewed. The team should review the Physical Flow Chart and the Physical Flow Relationship Chart to ensure that the layout developed realistically meets the flow intent and does not violate any underlying relationships between process elements.

At the completion of this step, will have a carefully developed process layout that has been agreed to by all required stakeholders. In addition, the layout, and the process used to arrive at that layout, will have been carefully documented for future reference. The team should feel satisfied with their progress and supportive of the new process.

---

<sup>68</sup> Ibid, Page 54.

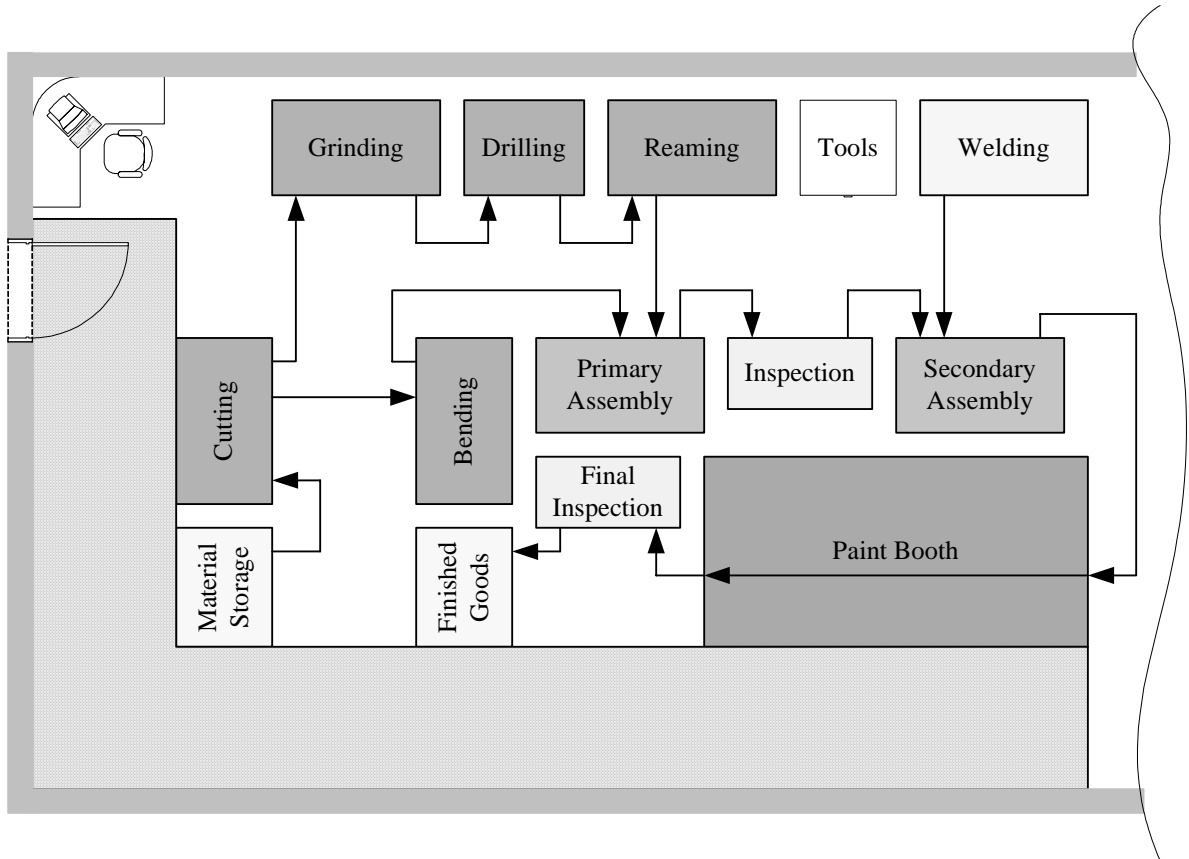

**Figure 8: A Sample Block Layout**

## **Part III**

---

### **Case Illustrations Where The Traditional Design Methodology Was Used**



A number of case illustrations can be used to illustrate how the basic building blocks of the layout design process are applied. Chapter 9 examines the production of an automotive ignition coil and can be used to demonstrate the effective use of a Physical Flow Chart. Chapter 10, which examines the placement of electronic components on a Formula One racecar, can be used to demonstrate the effective use of a Physical Flow Relationship Chart. Chapter 11, examining the production of Krispy Kreme<sup>®</sup> Doughnuts, can be used to demonstrate the effective use of a Physical Flow Block Layout Diagram. Finally, Chapter 12, which examines the design of the manufacturing system for the production of an automotive starter motor, illustrates the use of all three foundational elements together and demonstrates how the traditional design methodology was used on a recent design project.

### **9: A Physical Flow Chart For The Production of An Automotive Ignition Coil**

A major automotive components manufacturer recently assembled a process design team to evaluate and improve the process layout for the production of an automotive ignition coil. A rough representation showing the major parts of a typical automotive ignition coil produced by that manufacturer is shown in Figure 9.

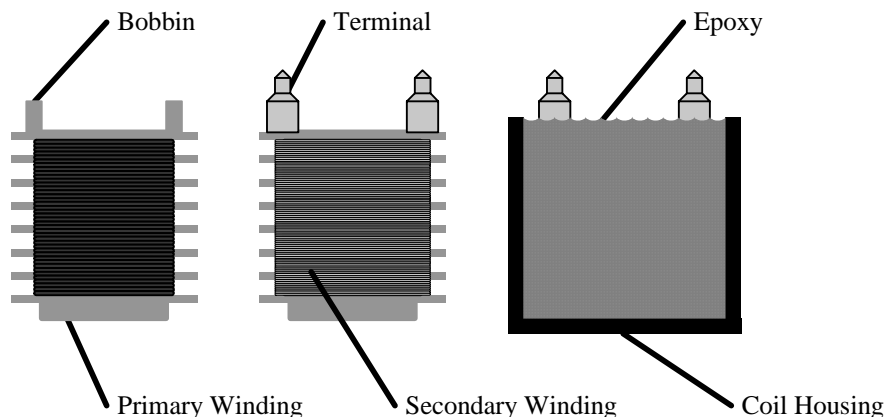

**Figure 9: A Representation of the Major Components of an Automotive Ignition Coil**

The team began the design exercise by constructing a Physical Flow Chart for the original production process. This Chart is shown in Figure 10.

The original production process had many Operations, two Inspections, and numerous Transport process elements. In addition, several negative process elements were present (Accumulate, Confound, and Interrupt).

The Stage Coils process, shown prior to the Autoclave Operations, is an example of an Accumulate process element, where the sequence of the parts became lost. Prior to this operation, parts were ordered, tracked, and kept in sequence by tracking numbers placed on the coil bobbin. However, at

this operation, the coils were taken off a conveyor belt and placed onto shelves, where they awaited the opening of the Autoclave, which was used to fully cure the epoxy that fills the housing. As the epoxy begins to cure, the epoxy became sufficiently clouded over so the tracking numbers on the coil bobbin were difficult to read. By the time the coils were placed into the Autoclave, the epoxy was opaque, completely obscuring the tracking labels. Therefore, unless the operator was quite careful when loading the coils into the Autoclave, the original order of the parts was lost, making it difficult to determine exactly when a specific part was made.

Next, the Route process, prior to each of the winding operations, actually created the downstream Confounding operation after the winding operations. This was because parts are sent to any one of four primary coil winding machines, and then collected back together where they were then sent to any one of four secondary coil winding machines. Therefore, there were sixteen different ways a completed coil can be produced, which greatly complicated the traceability of the parts.

Finally, the winding operations were subjected to several Interrupt elements. This was because each winding machine was capable of producing multiple coil profiles for different products, and allocation of winding machines across product types was continually shifted due to throughput levels.

To develop an improved process, the design team examined some specific aspects of the current process. The team began its systematic review process by examining the two Route process elements. Originally, these elements were implemented to ensure that parts could be shifted to another winding machine if the originally chosen winding machine was broken or under repair. At the time, this seemed quite logical, since the winding machines were unreliable when the process was first launched. Therefore, a sophisticated routing algorithm was put in place to shift parts to the winding machine that currently had excess capacity.

When all the machines were operational, the routing machine added complexity and time. But when a winding machine went down, the Route elements repeatedly proved their worth. Over time, however, the reliability of the winding machines had been dramatically improved, so much that they now rarely broke down. Thus, there were very few times where the complicated routing machine needed to be used.

The process team decided that the improved process would not utilize either of the two Route process elements. Instead each primary coil winding machine was paired directly with a secondary coil winding machine, creating only four possible paths through the system. Because of this decision, not



only were the two routing stations eliminated, but the two downstream Confound elements were also eliminated. As a result, the traceability of parts through the system was dramatically improved.

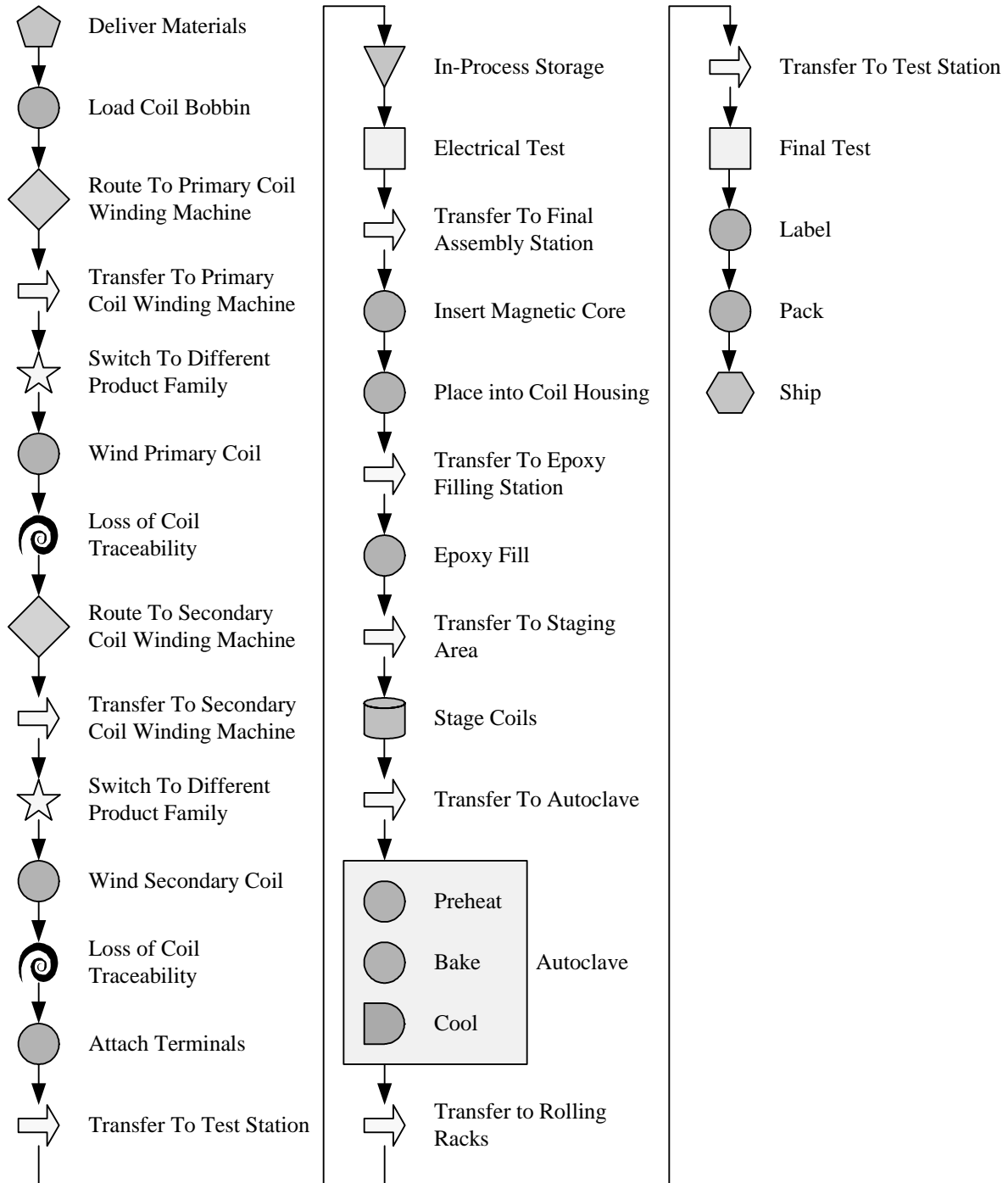

**Figure 10: A Physical Flow Chart For The Production of An Automotive Ignition Coil**

Next, the team examined the off-line Electrical Test station. The original process design had this station placed in a separate area, since two different machine vendors produced the test equipment and the assembly equipment. This decision not to integrate the systems was made in order to speed along equipment development time. By having the test station off-line, it was necessary to transport parts over to the test station, keep them ahead of the test station in an in-process buffer, and then transport the tested parts back to the assembly process. To improve the process performance, the team decided to integrate the test station with the assembly process. This change eliminated two Transport elements, as well an in-process Storage buffer.

Finally, the team closely examined the Stage Coils process element. In the current design, an operator took the filled coils, and placed them on a rack where they awaited the opening of the Autoclave. After the Autoclave completed its preheat, bake, and cool cycles, its doors were opened. The operator would then transfer the fully cured coils from the internal shelves of the Autoclave to rolling racks that would be brought to the Final Test station. The operator would then take the filled coils from the staging rack and place them on the internal shelves of the Autoclave.

After intense deliberation, the design team felt that little could be done to improve the cycles of the Autoclave. The Preheat, the Bake, and the Cool cycles were all needed in the production system. However, a subtle yet profound change was still made. It was discovered that, if minor changes were made to the rolling racks, the racks used to stage the coils could completely fit inside the Autoclave. By using common racks throughout the process, the operator could then simply swap a rack assembly of fully-cured coils with a rack assembly of to-be-cured coils. The coils would only have to be transferred twice, rather than the four times that existed in the prior process. Thus, two Transport elements were removed, and much of the time associated with the other two could be eliminated. Finally, the adverse effect of the Accumulate process element could be decreased.

The team pressed further to improve the process design for the ignition coils. For example, another improvement included changing the programs of the winding machines so that multiple winding patterns could be produced at once. This allowed multiple products to be run on the same line, thereby eliminating the two Interrupt process elements. After complete integration, these changes and others had dramatic improvements on the production performance of the assembly system.

This brief example has shown the level of valuable understanding a design team can develop through the construction of a Physical Flow Chart. Of vital importance is the recognition of the Accumulate, Confound, and Interrupt process elements. The presence of these elements should immediately signal to the process team that there is a strong potential for process improvement that would

result in more robust production. In addition, the presence of numerous transport elements shows that the further potential for improvement exists.

This example also showed how, once the process under consideration has been mapped using the Physical Flow Chart, the existing design could be examined in a systematic manner to identify areas for improvement. But even if no improvements can be found, the design team will still become much more knowledgeable about each and every process element.

## 10: A Physical Flow Relationship Chart for a Formula One Racecar

The world of professional motorsports offers a unique example of how a Physical Flow Relationship Chart can be used to determine ideal placement of process elements. Although this illustration does not involve manufacturing, the example shows us how the Physical Flow Relationship Chart can prove quite valuable and is therefore suited for use in numerous applications.

On a modern Formula One racecar, such as the one shown in Figure 11, there are as many as twenty on-board electronic computers that control the automatic control systems of the vehicle. These “black boxes” combine to form the neural backbone of the vehicle. For example, one box controls the vehicle’s power steering system, while another controls the vehicle’s communication system and still another controls the logging of critical vehicle dynamics behavior.



Figure 11: A modern Formula One racecar.<sup>69</sup>

Rather than combining all these units into one central computer, the units are split out by their core function. This not only allows for the optimal placement of weight in the vehicle, but this distributed system also creates some redundancy and robustness of the system.

In competition, there is always a high risk of damage caused by collision with another vehicle or a crash barrier. Additionally, damage may occur because the vehicle is operating at the ultimate edges of performance. Temperature, vibration, acceleration, and electrical interference levels all often exceed the design limits of the electronic components that make up the control system.

---

<sup>69</sup> Personal photograph taken by Kevin VanderLaan, Silverstone, UK. Photo used with permission of photographer.

Because of this potential for damage, the system must be made highly fault tolerant and redundant. Efforts must be taken to place components at strategic locations on the vehicle so that damage to one part of the vehicle affects as few systems as possible. In addition, some units must be placed near cooling systems of the vehicle, to keep them within operable temperature limits. Therefore, great care is taken to determine the optimal placement of the units so that the chance of catastrophic system failure is reduced.

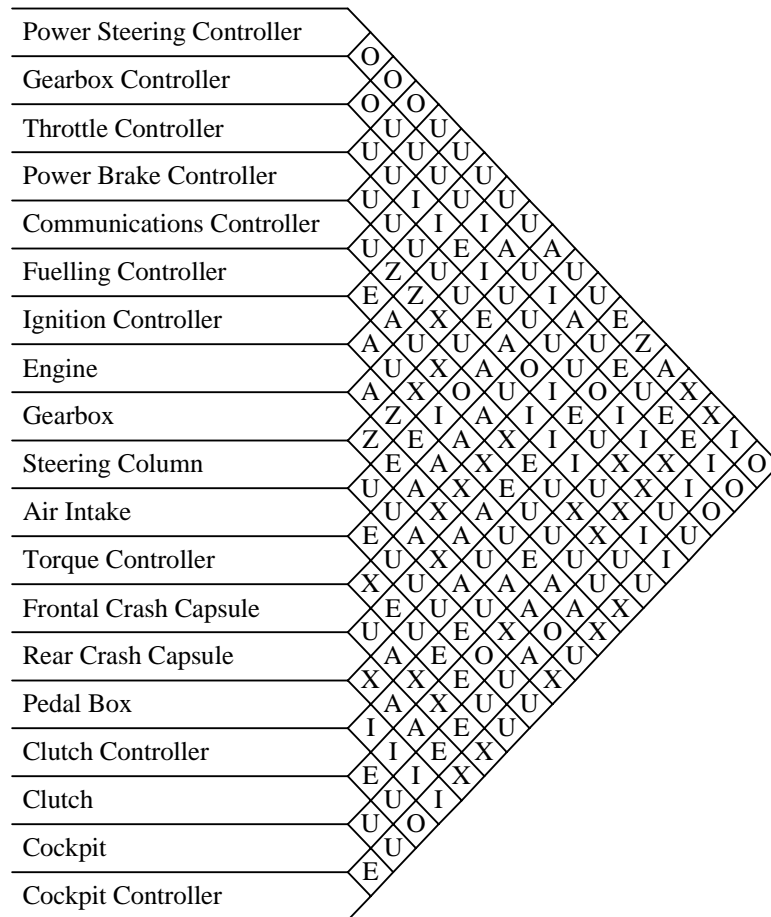

**Figure 12: A Physical Flow Relationship Chart For a Formula One Racecar's On-Board Electronics<sup>70</sup>**

Thus, the physical layout of these distinct electronic computers becomes a vital task of the vehicle designer. In fact, the design and layout of the car cannot proceed until the details of the on-board electronic system are known. Once these elements are discovered, a Physical Flow Relationship Chart can be developed to determine the ideal placement of each of these electronic components on the racecar.

<sup>70</sup> For simplicity, only the Proximity Ratings for the relationships are shown. In reality, numerical ratings for each Proximity Rating should also be given to remind the design team of the reasons that a specific Proximity Rating was chosen.

While there are almost two hundred relationships shown in Figure 12, some vital relationships can be described to show the valuable insight that can be gained by the design team through the generation of a Physical Flow Relationship Chart.

First, the Communications Controller's proximity to the Ignition Controller is extremely undesirable (Z). This is because the Ignition Controller generates high voltage spikes that are sent to the engine's spark plugs. These electrical spikes cause dramatic levels of electromagnetic interference (EMI). Since the Communication Controller is broadcasting data to the base station via radio waves, the clarity of the broadcast is negatively affected by this EMI. To maximize communication clarity, these two units must be kept as far away from each other as possible.

Next, the Power Steering Controller's Proximity Rating to the Steering Column is absolutely necessary (A). Under normal operation, the Power Steering Controller receives inputs from the Steering Column, and actuates the vehicle's rack and pinion steering. In theory, these systems only need to be connected by an electrical cable. However, a safety regulation requires that there is a mechanical linkage between the Steering Column and the Power Steering Controller, to still permit steering of the vehicle in the case of the Controller's failure. To satisfy this regulation, the Controller must therefore be directly mated to the Steering Column.

Finally, the Power Brake Controller's Proximity Rating to the vehicle's Air Intake is also absolutely necessary (A). This is due to need to cool the Controller, since the unit is subjected to tremendous temperature levels under braking conditions. By placing the Controller next to the vehicle's Air Intake, some of the airflow can be redirected to cool the Power Brake Controller.

These three relationships show the power of the Physical Flow Relationship Chart. The discovery of these relationships allow the team to identify location requirements that may not have otherwise been identified until late in the design process, where design modifications would have been extremely expensive.

In addition, the discovery of these underlying relationships helps inform the team of likely impacts to the overall system if the placement of one component must be changed. For example, when a decision was made to change the location of the communications controller, the routing of cooling vents in the vehicle had to be adjusted, due to the controller's absolute need to be near the vehicle's air intake.

This case, although not directly related to manufacturing, shows that by understanding and categorizing relationships between process elements, a properly sequenced process flow can begin to be developed, where those process elements that must be located close together are indeed linked, and those process elements that must be kept apart are indeed separated.

## **11: A Physical Flow Block Layout Diagram For Krispy Kreme® Doughnuts**

The visibility of Krispy Kreme®'s production process is a small part that contributes to the overwhelming popularity of their doughnuts. Each retail store is actually a production facility that bakes all doughnuts sold at their stores, through supermarkets, and through organizational fundraisers. In these “factory-stores”, customers can observe the entire production layout while waiting to buy doughnuts. These stores provide a unique opportunity to imagine how a Physical Flow Block Layout might have been used to determine optimal placement of process elements.

There are twelve major process steps involved in the production of a Krispy Kreme® doughnut. These steps<sup>71</sup>, and their sequence are:

1. Mix ingredients in hopper
2. Extrude batter to form rings
3. Proof batter<sup>72</sup>
4. Fry bottom side of doughnut
5. Flip doughnuts over
6. Fry top side of doughnut
7. Cool doughnut
8. Apply sugar glaze
9. Cool doughnut
10. Inspect quality
11. Box and store doughnuts
12. Distribute finished product

In determining the production system layout, the design team likely had to consider several important factors that would influence the production process. First, since the exact ingredients that go into a Krispy Kreme® are a trade secret, the mixing operation must be performed in a location that cannot be observed by the general public. Similarly, the machine that extrudes the batter is a proprietary design that is unique to Krispy Kreme®, so it too must be hidden from view. Next, the proofing operation takes up to 45 minutes per doughnut. Since doughnuts come off the end of the line at a rate of roughly 10 per minute, the proofing equipment must contain approximately 450 doughnuts in order to maintain a steady stream of product at the end of the production process. Other process steps take much less time, so this suggests that the size of the proofing process must be large relative to the other elements. Another vitally important design influence was the customers must be able to be given doughnut samples as the doughnuts are being cooled. Finally, customers waiting to purchase doughnuts must be able to easily

---

<sup>71</sup> “How Krispy Kremes Work”, Tom Harris, <http://money.howstuffworks.com/krispy-kreme.htm>, March 23, 2003.

<sup>72</sup> “How Krispy Kremes Work”, Tom Harris, <http://money.howstuffworks.com/krispy-kreme.htm>, March 23, 2003: “The purpose of the proof box is to surround the doughnuts with heat and humidity. Humidity and low heat make the yeast organisms more active without killing them. When the yeast becomes active, it eats sugar and releases carbon dioxide gas as a waste product. The carbon dioxide expands, creating air pockets all through the dough”

observe all of the process elements (with the exception of the mixing and extruding processes). Therefore, the major design influence factors are:

- Mixing operation must be hidden from view
- Extrusion machine must be hidden from view
- Proofing equipment will likely be largest piece of equipment
- Customers must be near the second doughnut cooling area
- Customers must be able to view all process steps with the exception of the mixing and extruding steps.

In addition to the process operations, the design team must have been aware of the supporting activities and areas that would interact with the process. These elements included the customer waiting area, the finished product display area, the payment collection area, the seating area, the restrooms, and the drive-through window.

Once the design team had identified all process elements and the sequence of process operations, the design team likely would have considered each of the traditional flow patterns in order to identify the best physical configuration for the process.

A straight flow pattern would have the advantage of allowing a high level of visibility for each process operation. Customers could observe the process on one side, and operators could work on the other side. However, finished doughnuts coming off the end of the line would have to be packaged and brought back to the beginning of the process, where the shipping and receiving docks were located. To accomplish this, cooked doughnuts would have to be passed through an area where uncooked doughnuts were being prepared, which likely is a violation of health regulations. Therefore, neither the straight flow pattern, nor the similar L-shaped flow pattern, were acceptable configurations. And, due to the small number of process operations, the complex configuration of a serpentine pattern would not be needed.

A U-shaped flow pattern would allow for high visibility of the process and a high level of communication between operators. However, with this design, the final cooling operations (where sample were to be given to customers) would lie quite close to the mixing and extruding operations. Since those operations must remain hidden, this configuration would not be ideal.

The design team ultimately chose a circular flow pattern. Although parts would not have to be sent through the manufacturing process more than once, the circular flow would permit high visibility, support product sampling, and still prevent the critical operations from being observed.

If the design team had created a Relationship Chart, it may have resembled that shown in Figure 13. This Chart shows that most processes only have to be absolutely near two other operations (the immediately upstream and downstream processes). The first two operations (mixing and extruding) must

be kept separated from all other operations. Finally, due to common resource sharing, it would be convenient for the mixing and the distribution of finished product operations to be close together.

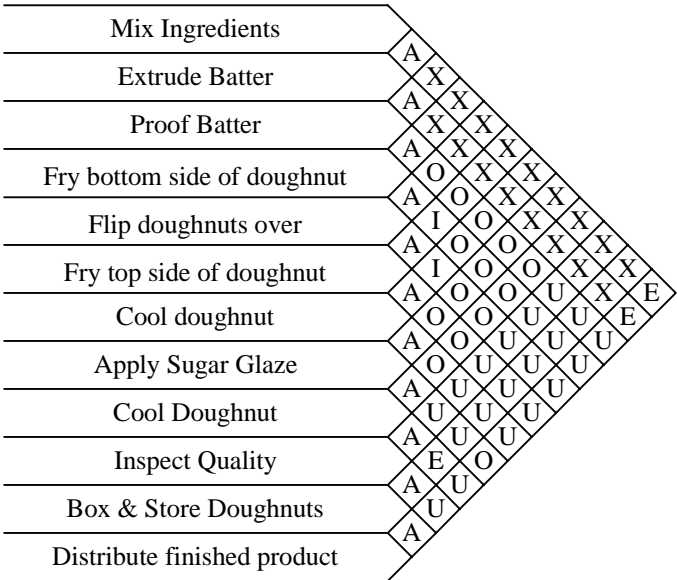

**Figure 13: Physical Flow Relationship Chart for the Krispy Kreme® Production Process**

After identifying the required sequence, discovering the underlying relationships, and selecting and appropriate flow pattern, the design team likely created a Physical Flow Block Layout Diagram, similar to the one shown in Figure 14.

Once this initial Physical Flow Block Layout Diagram was been developed, the design team likely considered more specific aspects of the production process, such as issues related to safety, maintenance, material storage, and future expansion.

Although this case illustration is based solely on conjecture, it is likely that the process design team would have followed a similar path to develop the manufacturing system. By considering all process elements, as well support elements and external constraints, an optimal process layout would have been developed.

Therefore, it is clear that the Physical Flow Block Layout Diagram is an extremely helpful tool that the design team can use to visualize different design concepts for a manufacturing system. The physical placement can be reviewed, external constraints can be discovered and accounted for, and the interactions between the production system and its surrounding environment can be examined.



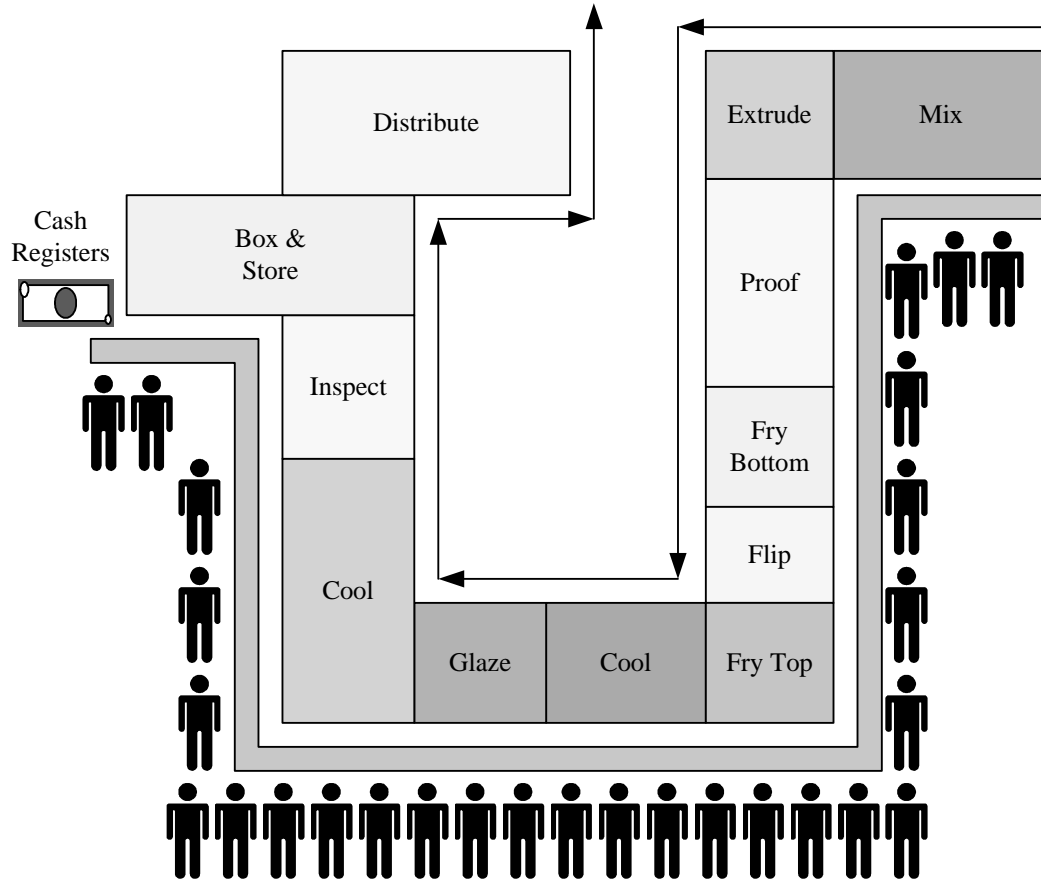

Figure 14: A Physical Flow Block Layout Diagram for the Krispy Kreme® Production Process

## 12: Designing a Manufacturing System for an Automotive Starter Motor Solenoid Subassembly

The traditional methodology used in manufacturing system design can be summarized by examining an actual design project: the designing of a floor layout for the manufacture of an automotive engine component. This complete example will illustrate the use of the three major process design elements: the Physical Flow Chart, the Physical Flow Relationship Chart and the Physical Flow Block Layout Diagram. The successes of this design project will be reviewed. In addition, the shortcomings of this design project, which occurred by neglecting several key informational elements, will also be presented.

A major automotive manufacturer recently opened a new production complex in southern India. This new complex would produce engine and body components, which would be assembled into vehicles for the Southeast Asian Region.

One of the components produced in this complex was a Starter Motor, the component that is used to start an automobile's engine. In total, the Starter Motor (represented in Figure 15) is comprised of

approximately 100 individual parts, which can be grouped into 6 major subassemblies (the motor frame, the armature, the commutator, the solenoid assembly, the output drive assembly, and the external housing).

A process design team was assembled and charged with launching a new manufacturing system to produce these starter motors. The major mission of this project was to become the lowest cost production site for starter motors by designing a system based firmly on Lean Production principles. The design project focused on many areas, including the micro-level design of individual pieces of process equipment, the macro-level design of the process layout for each assembly, as well as the system design of the final assembly process.

This case will examine one aspect of that process: the production of the solenoid assembly and will demonstrate how the layout of that process was developed using traditional manufacturing process design methods.

The solenoid assembly consists of three major subassemblies: the wire wound coil assembly, the solenoid contact and cap assembly, and the internal plunger assembly. During the production process, these subassemblies are mated and encapsulated in an outer housing. Once the subassemblies are combined together, the solenoid assembly cannot be torn down into individual components without causing irreparable damage to the subassemblies. Therefore, once the items has been assembled, it must be scrapped if found defective. Figure 16 shows a representation of the major components of the Solenoid Assembly.

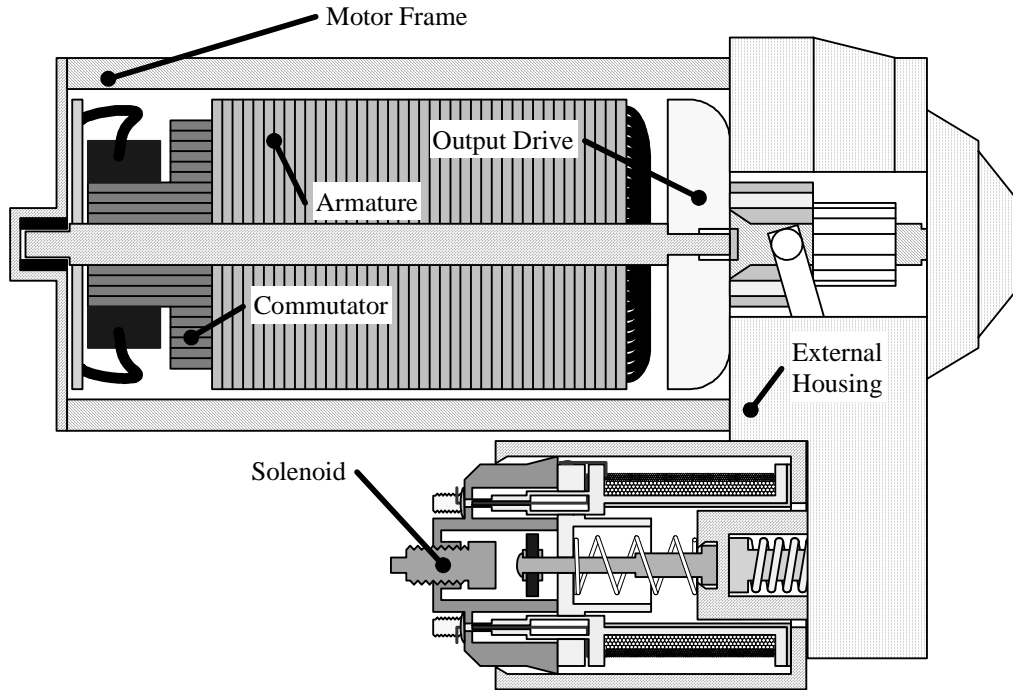

**Figure 15: Major Components of an Automotive Starter Motor**

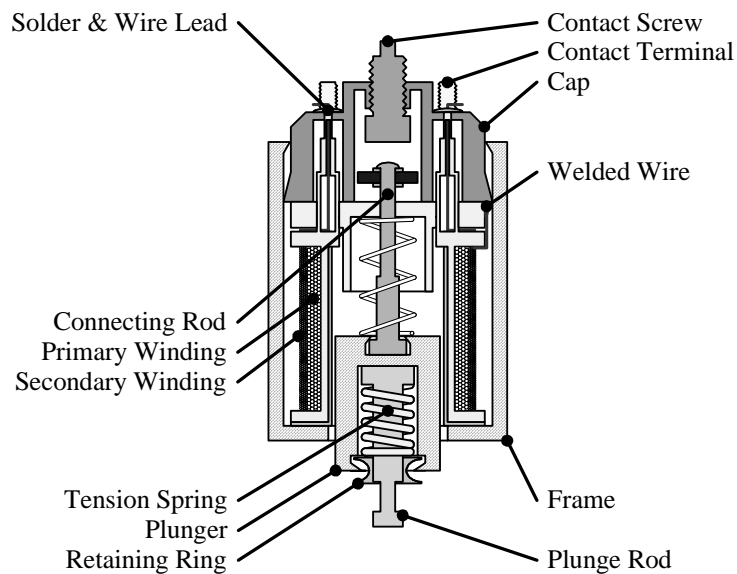
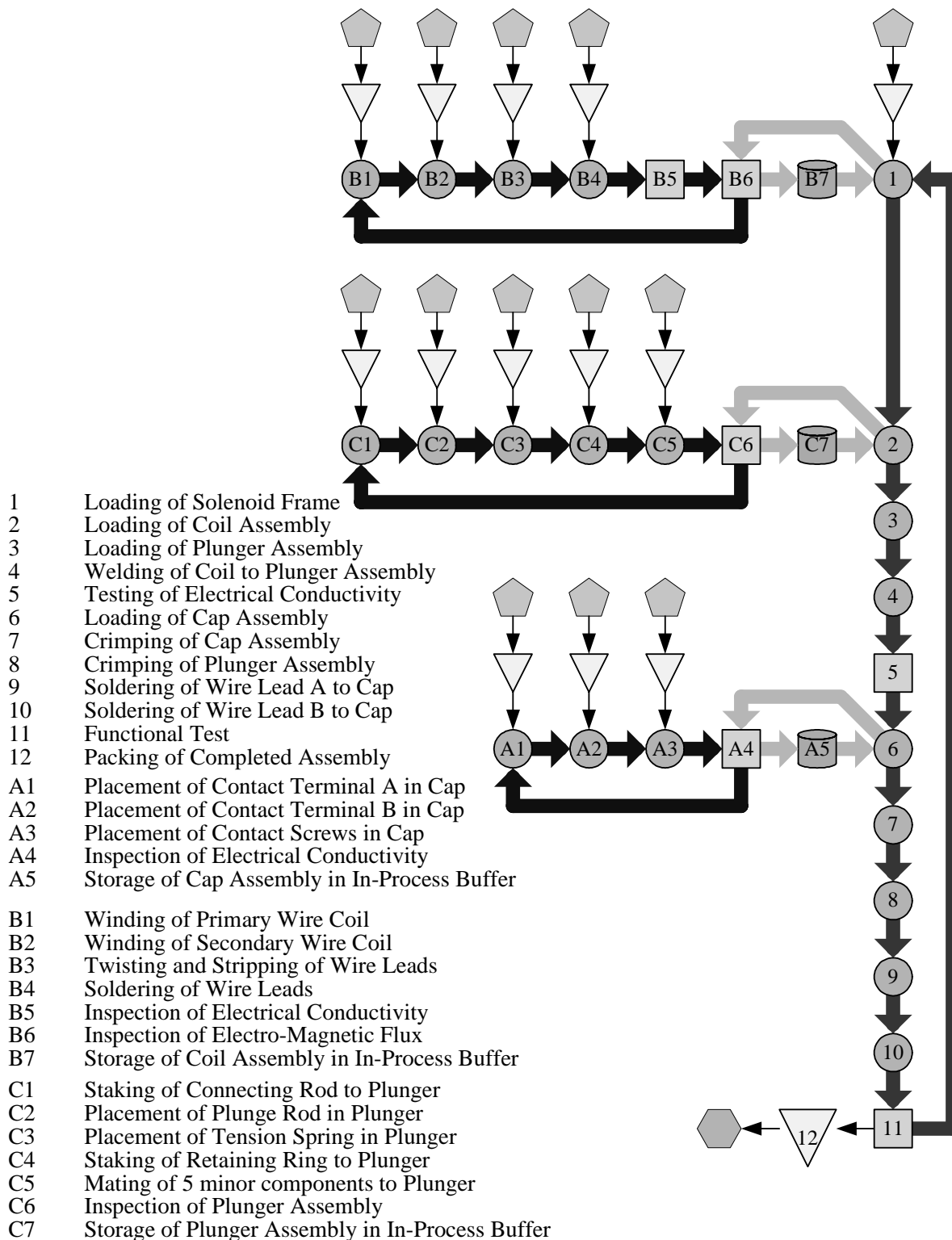

**Figure 16: Major components of the Solenoid Assembly**

The design of the solenoid assembly is quite mature and this component has been produced at various worldwide locations for many years. Each of these locations utilizes a standardized configuration of high-volume, capital-intensive, automated equipment to produce the components. In that common configuration, the major process elements include:

- Automation System A:
  1. Placement and Securing of Contact Terminal A in Cap
  2. Placement and Securing of Contact Terminal B in Cap
  3. Placement and Securing of Contact Screws in Cap
  4. Inspection of Electrical Conductivity
  5. Storage of Cap Assembly in In-Process Buffer
- Automation System B:
  1. Winding of Primary Wire Coil
  2. Winding of Secondary Wire Coil
  3. Twisting and Stripping of Wire Leads
  4. Soldering of Wire Leads
  5. Inspection of Electrical Conductivity
  6. Inspection of Electro-Magnetic Flux
  7. Storage of Coil Assembly in In-Process Buffer
- Automation System C:
  1. Staking of Connecting Rod to Plunger
  2. Placement of Plunge Rod in Plunger
  3. Placement of Tension Spring in Plunger
  4. Staking of Retaining Ring to Plunger
  5. Mating of 5 minor components to Plunger
  6. Inspection of Plunger Assembly
  7. Storage of Plunger Assembly in In-Process Buffer
- Main Assembly Automation System:
  1. Loading of Solenoid Frame
  2. Loading of Coil Assembly
  3. Loading of Plunger Assembly
  4. Welding of Coil Assembly to Plunger Assembly
  5. Testing of Electrical Conductivity
  6. Loading of Cap Assembly
  7. Crimping of Cap Assembly
  8. Crimping of Plunger Assembly
  9. Soldering of Wire Lead A to Cap
  10. Soldering of Wire Lead B to Cap
  11. Functional Test
  12. Packing of Completed Assembly

Figure 17 shows the Physical Flow Chart that was constructed for the existing production processes.



**Figure 17: Physical Flow Chart for Automated Production of Solenoid Assembly**

In each of the subassembly processes, as well as the final assembly process, there are elements of hard-automation that transfer pallets holding parts from station to station. These transfer elements operate in a circular fashion. Parts are manually or automatically loaded at the first station where the first operation is performed. The transfer system then automatically moves pallet containing the part through the process where the remaining operations are completed. Once the pallets reach the last operation, parts are unloaded, and empty pallets are returned to the first station to be reloaded. Even though the automated transfer system reduces the level of operator intervention required, the use of the pallets has a major disadvantage. The transfer system directly couples process stations, so any minor stoppages or delays causes blocking or starving of upstream and downstream operations. These minor stoppages dramatically add up throughout the day to reduce the overall production rate of the system.

To make the feeder lines of subassemblies still able to produce parts even if the final assembly process was down, automated in-process storage systems were implemented. In this system, completed subassemblies are transferred from the subassembly pallets to holding area. Then, parts are removed from the holding area and transferred to the pallets on the final assembly line. Although these transfer systems decouple the lines from each other, they introduce other problems. In-process inventory increases, leading to longer product lead times and higher exposure to quality defects. In addition, although the process was highly automated, the process still needs to be staffed by multiple operators in order to cope with process faults, as well as to ensure parts were not being damaged during transfer or storage. Finally, the maintenance required to keep the complex automation equipment functioning properly is significant.

Finally, since this is a highly automated process, each operation has its parts automatically fed via part hoppers or vibratory bowls. Although this decreases the effort to load parts, parts often jam in the hoppers, stopping further production of the process until an operator can address the issue.

Clearly, there are several disadvantages of the design of the automated process. It was due to these shortcomings (the low process performance, the high labor requirements needed to monitor the process, the escalating maintenance costs, and the high capital cost of the automated equipment and the transfer systems) that plant management felt a fresh design would be implemented in the India plant.

Following the traditional process design methodology, the design team began its project by examining the automated process to potential areas for improvement. However, since the production system being designed would utilize variable volume, non-automated equipment, the design team needed to develop fresh ideas to achieve high production performance.

Upon reviewing the Physical Flow Chart, the team immediately located several process steps that could be eliminated. In addition, several steps could be combined, which would eliminate the need to

transfer parts, and reduce overall complexity. Also, since the complexity of the new equipment would be significantly reduced maintenance costs would decrease. These improvements in the manufacturing system design would reduce overall cost of the system, satisfying the key requirement of the project.

The design team brainstormed these and other possible changes that could be made to improve the process. The team identified the following specific improvements:

- Eliminate all automatic feeding of parts to operations. The hoppers and vibratory bowls were expensive, and their historical performance was not sensational. Manual loading and unloading would be more reliable and cost less than the expensive automation equipment.
- Eliminate automatic transfer of parts between stations. This would not only dramatically reduce cost of the project, but would decouple each station from the others, reducing the effect of blocked and starved conditions.
- Eliminate storage areas of subassemblies. By increasing the production rate of the subassembly lines above that of the final assembly line, the subassembly lines could be operated in a pull-type system, producing parts only when the final assembly line required them. This elimination of the in-process inventory would allow for better traceability of produced parts, reduce the overall floor space required, and reduce the exposure to quality defects.
- Combine the testing of Electrical Conductivity operation with the Welding of Coil to Plunger Assembly operation. This would permit defective parts to be immediately caught at the source.
- Combine the Electrical Conductivity and Electro-Mechanical Flux functional tests performed on the Coil Assembly into one station. Again, this would permit defective parts to be immediately caught at the source.
- Combine the two Placement and Securing of Contact Terminals in Cap operations into one operation. This reduces the overall number of process stations without introducing too much added complexity.
- Incorporate the Inspection of Electrical Conductivity performed on the Cap Assembly into the previous operation. Once again, this would permit defective parts to be immediately caught at the source.
- Combine the three Plunger Assembly operations (Placement of Plunge Rod in Plunger, Placement of Tension Spring in Plunger, and Staking of Retaining Ring to Plunger) into one operation. Doing so would reduce the overall number of process stations without introducing too much added complexity.
- Combine the Loading of Cap Assembly, the Crimping of Cap Assembly, and the Crimping of Plunger Assembly into one semi-automated station. In this station, the operator would load the cap assembly, and then activate the tooling, which would then descend to perform the crimping operations. Once again, doing so would reduce the overall number of process stations without introducing too much added complexity.

Once these process improvements were identified, and the process elements were reduced to their core functions, a Physical Flow Chart for the improved design was prepared. Figure 18 is an abstraction of the Physical Flow Chart that was developed for the improved Solenoid Assembly Process.

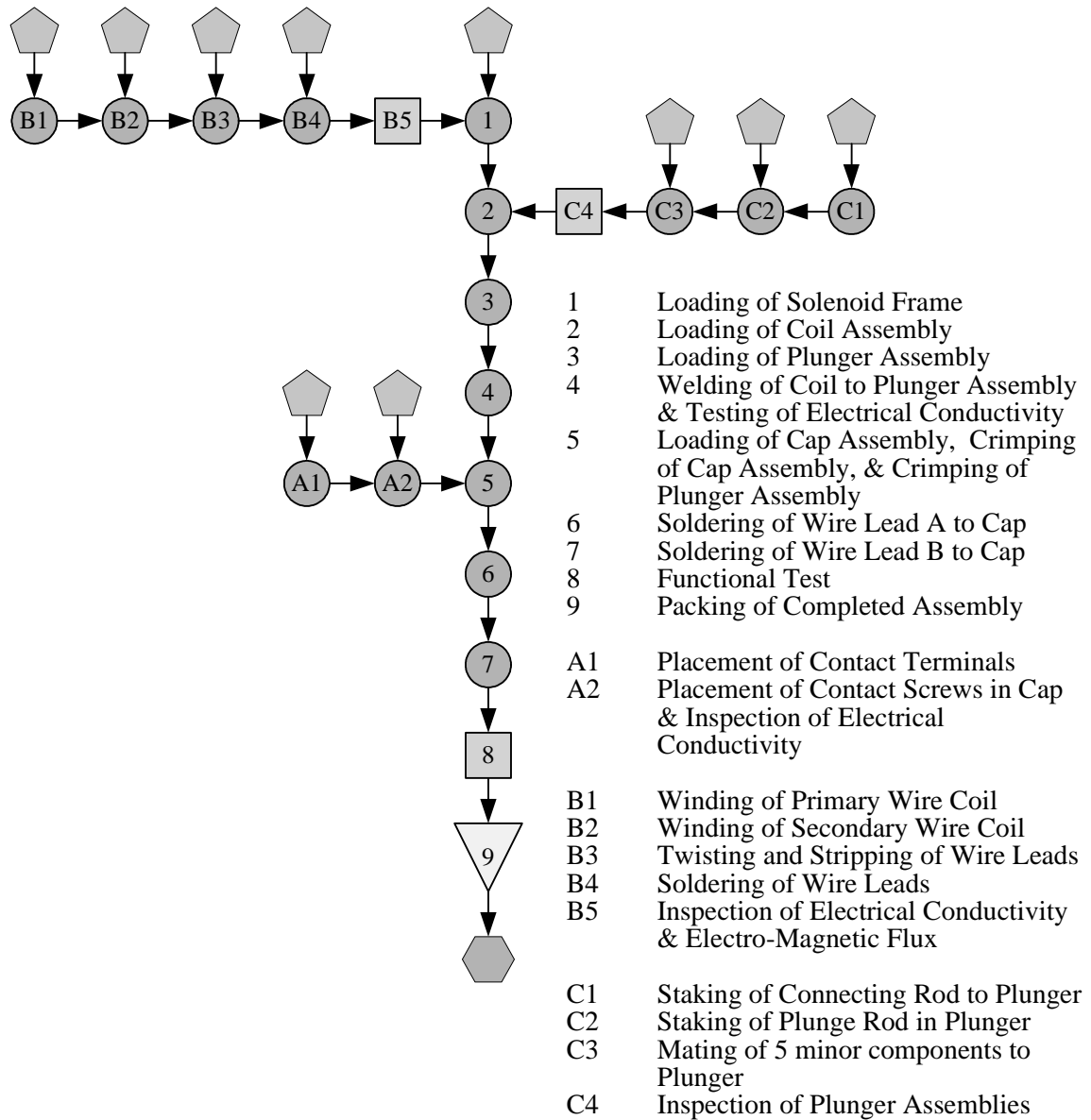

**Figure 18: A Physical Flow Chart for the Improved Production Process of a Solenoid Assembly**

It is clear that this Physical Flow Chart is much simpler than the Chart for the original process. First, the total number of main line process elements was reduced from 12 to 9. The number of subassembly feeder elements was reduced from 19 to 11. Even more drastic reductions were made in the total number of process elements, if the elimination of automatic part feeders is factored into the calculation. Next, the expensive and troublesome hard automation, as well as the automated transfer equipment, was eliminated. In addition, the in-process storage buffers were eliminated. Finally, quality inspection operations were moved further upstream and incorporated directly into process operations.



All of these simplifications have numerous benefits, such as better control and performance of the process, lower inventory levels, less propagation of quality errors, and lower maintenance costs. In addition, fewer operations means less floor space would be required, allowing for more products to be brought into the newly constructed factory.

Because the number of operations had either been eliminated or combined, the design team had to ensure that underlying relationships between process elements were left intact. To review this, the team constructed a Physical Flow Relationship Chart, shown in Figure 19.

This Physical Flow Relationship Chart shows that there are many process elements that are completely unrelated. However, there are also some pockets where the process elements are densely related, such as the operations involved in the production of the Plunger Assemblies. This confirmed the design team's assumption that it is beneficial to group the production system into individual work cells that would each feed the main assembly line. In addition, the lack of relationships between many process elements showed the team that direct coupling of process elements was not needed, and manual transfer of parts between stations would meet the requirements of the process.

This Physical Flow Relationship Chart also showed that the final Functional Test is related to each process element. Thus, it should be placed in a central location.

The Chart also showed that there are no process elements that could not or should not be located near each other. Therefore, the team had relatively few design constraints that would adversely affect the process design.



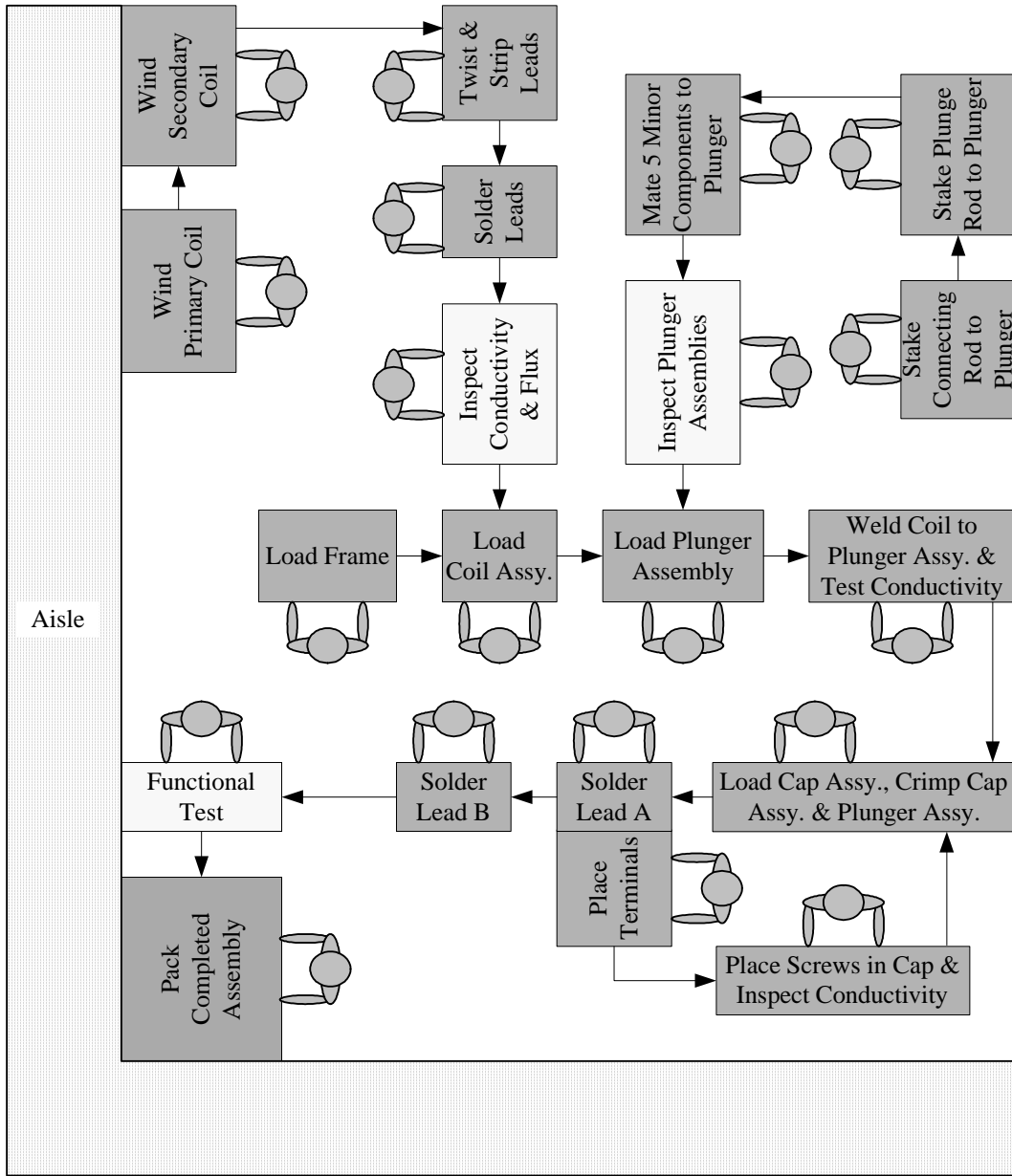

**Figure 20: A Physical Flow Block Layout Diagram for the Production of a Solenoid Assembly**

The new process design allows the production level to be adjusted quite dramatically, as volume demand changes. In Figure 20, nineteen operators are shown, which is the staffing level required for maximum production. However, since the subassembly lines operate at a rate faster than the main line, the feeder cells can be manned by fewer operators without adversely affecting production. Operators can flex between stations as needed, depending on production demands.

Since the process elements are no longer directly coupled, stations are no longer affected by minor stoppages caused by pallet congestion or material loading issues. In addition, if an operator is not present, production can still flow through the line, since cross-trained operators can move between stations and perform the needed tasks. This was not possible with the automated system, since operators were not trained to perform the operations, only to maintain a specific piece of automated equipment.

Finally, all the locations for storage of in-process inventory have been eliminated. Parts are now passed directly to the downstream process, where they are immediately processed. The elimination of this inventory reduces the process' exposure to quality defects, improves traceability and accountability of parts, and maintains level production at a predictable and stable rate.

The improved design implemented by the project team produced numerous benefits. In addition to those already described, the new process created a highly cohesive work-team by enabling improved communication and overall awareness of the process. This work-team embarked on a continuous improvement effort, and worked to further optimize the design of the process. As the operators became more accustomed to the process, three operations were either eliminated or combined with other operations. This decreased the staffing requirements, while yielding even higher production volume and quality. Overall, the actual performance of this manufacturing process was better than expected. And currently, the plant continues to successfully produce the lowest cost and highest quality starter motor for the company. Indeed, the cost advantage enjoyed by this facility has enabled it to win new business from automakers producing vehicles for Europe and South America, not just the intended Asian market.

This case has demonstrated that the traditional design process used in the design of a manufacturing system. It has shown that the use of the Physical Flow Chart, the Physical Flow Relationship Chart and the Physical Flow Block Layout Diagram can result in an optimal design of a manufacturing system. The generation of the Physical Flow Chart identified several opportunities where the process could be improved, by eliminating, combining or resequencing various operations. The Physical Flow Relationship Chart proved that process elements could be clustered together to minimize travel distance and overall process footprint. Finally, the Physical Flow Block Layout Diagram allowed the team to graphically optimize the layout and location of each process element, based on the underlying process needs and relationships identified in the design process.

As successful as the solenoid assembly process design was, the design team failed to recognize some key factors that have recently begun to hinder the plant's progress. These factors were never even

considered by the design team simply because the traditional design methodology used to develop the process did not place any emphasis on their consideration.

Overall, the design team failed to consider the flow of information through the process. This oversight led to: (1) lost chances to catch quality defects before they escaped the process, (2) unneeded time and effort spent monitoring and recording production data that was already automatically being collected, and (3) costly equipment modifications late in the launch process.

Specifically, the team did not identify how the output from the four different functional tests could be linked in order to diagnose the behavior of the production system. Rather than being combined together and compared to each other, the results of each functional test were held separately. Any aggregation and subsequent analysis of this information could have led to the discovery of systematic quality defects that were not detected by the individual functional tests. Having such a system in place could have prevented led to the earlier detection of some minor, but systematic, quality issues.

Next, the team did not make use of some of the valuable information-gathering abilities of the process. To monitor production rates, operators were asked to log the number of parts produced (as well as those scrapped) per hour and were asked to record any major machine stoppages and the apparent cause of those stoppages. However, it was later discovered that several of the process machines were automatically recording the exact same information, but the team was not aware of the data collection. Significant training resources and effort had been spent developing a system that was completely redundant.

Next, it was discovered that the team did not implement proper monitoring systems for the results of each functional test. The design team believed that simple pass/fail tests were sufficient to capture the behavior of the process. However, for some elements, it was vital to examine the trend of behavior over time. For example, rather the simply passing the conductivity test after the weld operation, the team should have implemented controls that examine the quality of the weld, to determine the appropriate time to exchange weld tips. Control algorithms had to be modified on-site (at high cost) to have variable data output from the functional tests so it could be used for statistical control purposes.

Finally, the team did not adequately require implement systems that would allow remote monitoring of the process equipment. Near the end of the launch period, company management expressed a desire to be able to compare the performance of each facility producing starter motor components to be able to evaluate different manufacturing techniques. The design team had not anticipated this request, and as a result had to implement less-than-optimal systems that would provide the desired results. The process put in place was highly manual and tedious for operators to perform. If the design team had known about this requirement during the development of the process, a more

streamlined system could have been incorporated into the original process design. In addition, the costs associated with making these changes late in the process could have been avoided.

Had the design process included the review and consideration of some of these elements, it is believed that the project would have been even more successful. If these issues had been anticipated, the added costs, timing, and efforts needed to implement these changes late in the project could have been minimized. The team could have greatly benefited from an improved design methodology that takes into account the design of informational flow systems and earlier identification of external constraints and requirements.

## **Part IV**

---

### **Developing An Improved Process Design Methodology**





### **13: Shortcomings of the Traditional Process Design Methodology**

The traditional methodology used in manufacturing system design has two significant shortcomings. These oversights have led to the creation of marginally effective and overcomplicated process designs that require more time, effort, and resources to develop than necessary.

First, the traditional process design methodology focuses only on the flow of physical parts through the system and neglects the flow of information. In many manufacturing systems, the flow of information has become extremely important to the firm and in some cases, the flow of information is more vital to the performance of the process than the flow of physical material. This suggests that any design process must place an equal emphasis on the design of the information system. Unfortunately, the traditional design methodology does not, since it largely ignores the flow of information. As a result, the ultimate performance of the manufacturing system is compromised.

The second major shortcoming is the overly sequential nature that the traditional design methodology uses to progress through activities and the methodology's failure to include all interested parties in the early stages of the design process. While the traditional design methodology does require the design team to solicit and consider interests of outside stakeholders, this attention is not paid until quite late in the design process. As a result, many significant factors that influence the process design will not be found until substantial effort has already been invested into the design and development of the manufacturing process. Then, since the process design is extremely detailed at this juncture, only minor design changes to accommodate the new considerations are possible. But, even making those minor changes requires considerable work and likely delays the overall project. Still more damaging, by waiting until the late stages to seek outside input, the design team could potentially discover a particular aspect that requires complete reevaluation of the process design. Should that occur, the design team would have to restart the entire design process, losing valuable time and wasting substantial effort.

These two deficiencies combine to reduce the effectiveness and applicability of the traditional design methodology in today's competitive marketplace. As it becomes necessary to increase the speed at which products and processes are developed, and as the information content of products and processes continues to expand, the manufacturing process design team needs a better tool to use for process design. Such an enhanced methodology would offer techniques that will reduce the overall time to design a process, reduce of the overall complexity of the process, and fully integrate the design of the physical production system with the design of the informational system.

By addressing both of these shortcomings, and by developing techniques that minimize or eliminate their negative effects, a much improved process design methodology can be developed.

## **14: Addressing the First Major Shortcoming: Ignoring the Flow of Information**

As mentioned, the first major shortcoming of the traditional process design methodology is its sole focus on the flow of physical parts and its neglect of the flow of information.

As a result of this shortcoming, the need to collect and manage information is often reviewed only after the process has been launched. Consequently, information systems are usually only introduced where needed, and often do not link all elements of the production system. Each information source receives different treatment and is dealt with using a different information management system. The result is an extremely disjointed and incompatible information network.

Reviewing the benefits that can be realized through the use of information, and studying the damaging effects that occur when information is not used in a comprehensive manner, will clearly demonstrate the importance of considering the design of an integrated information system and show why the traditional design methodology must be revised.

### **The Power of Information**

#### Information Sources and Uses in A Manufacturing Setting

Information has become “today’s key resource”<sup>74</sup> and is a fundamental determinant of a modern manufacturing firm’s success. As manufacturing systems continue to become more complex, it has become “clear what an enormous impact the use of [information] could have on the lead-time, cost, quality, and complexity of new designs.”<sup>75</sup> The use of information has penetrated all aspects of a manufacturing company and detailed information is now a vital input needed to perform many tasks, such as making high-level decisions, carrying out simulations, and optimizing factory operations.<sup>76</sup>

Information-based decision-making has transformed the modern business environment. Using objective information, decisions are made using data rather than instinct and Managers become more aware of the underlying factors responsible for the performance of a production process.<sup>77</sup> Using this

---

<sup>74</sup> Manufacturing Databases and Computer Integrated Systems, Dimitris N. Chorafas, CRC Press, Boca Raton, Florida, USA, 1993, Page 32.

<sup>75</sup> “Essential Considerations When Incorporating Computer Automation Technologies Into Design And Manufacturing Operations”, Jacobo Bulaevskysy, Applications of Computers to Engineering Design, Manufacturing, And Management, Proceedings of the IFIP TC 5 Conference on CAD/CAM Technology Transfer: Applications of Computers to Engineering Design, Manufacturing, and Management, Elsevier Science Publishers B.V., Amsterdam, The Netherlands, 1989, Pages 273-274.

<sup>76</sup> Manufacturing Information Systems, Luca G. Sartori, Addison-Wesley Publishing Company, Wokingham, England, United Kingdom, 1988, Page 9.

<sup>77</sup> “Interfacing Technology for Manufacturing Industry: From Islands of Automation to Continents of Standardisation and beyond”, Nigel Shaw, Interfaces In Industrial Systems For Production and Engineering: Proceedings of the IFIP TC5/WG5.10 Working Conference on Interfaces in Industrial Systems for Production and

enhanced understanding, better decisions can be made. “The more knowledgeable we are when we make a choice, the more responsible the choice is going to be.”<sup>78</sup> Therefore, the comprehensive use of information greatly assists in managing a firm’s activities.

However, when making decisions about a firm’s processes, the use of information is not only a convenience, it is a fundamental necessity to remain competitive. While “the company that masters the management of information...is destined for global economic leadership of historic performance,”<sup>79</sup> firms that fail to harness the power of information are destined for below average performance and will continually languish behind industry leaders. Therefore, to remain competitive, today’s firms must embrace information and have systems in place that monitor, record, and analyze information.

Many manufacturing firms have turned to advanced computer-based technology as the foundation for an information system. While a computerized system is not always required, the dramatic advancements in computer technology made over time have made computers increasingly attractive to many firms. Several types of computer based information systems exist, and may include<sup>80</sup>:

- Monitor and control systems
- Communications
- Display and user interface systems
- Database management systems and their databases
- Data collection systems, production information systems
- Peripheral devices (e.g., printers, magnetic sources, monitors, bar code readers, infrared tracking systems)
- Production accounting and reporting
- Statistical process/quality control (SPC/SQC) systems
- Time and attendance recording
- Preventive/corrective maintenance support systems

These computer based systems make it much simpler to manipulate information and provide manufacturing managers with an arsenal of tools to diagnose the underlying production process.

The use of advanced systems is usually required due to the incredible amount of information that is generated by each component of a typical manufacturing system. In these settings, some data is specific and quantitative in nature, such as a measured dimension on a physical part. Other data is more

---

Engineering, Darmstadt, Germany, March 15-17, 1993, J. Rix and E.G. Schlechtendahl (Editors), Elsevier Science Publishers, B.V., Amsterdam, The Netherlands, 1993, Page 3.

<sup>78</sup> Manufacturing Databases and Computer Integrated Systems, Dimitris N. Chorafas, CRC Press, Boca Raton, Florida, USA, 1993, Page 32.

<sup>79</sup> “Motorola Enterprise Integration Committee”, Robert Glavin, Jr., Motorola Company Report, Schaumburg, Illinois, USA, 1990.

<sup>80</sup> “Perspectives on Manufacturing Engineering Software Integration”, C.R. McLean, Information Infrastructure Systems For Manufacturing: Proceedings of the IFIP TC5/WG5.3/WG5.7 International Conference on the Design of Information Infrastructure Systems For Manufacturing, DIISM 1996, Jan Goossenaerts (Editor), Chapman & Hall, London, 1996, Page 27.

abstract and qualitative, such as the level of operator fatigue. However, each piece of information is extremely valuable, and should be captured and communicated throughout the system.

Not only is information generated in a manufacturing system, but much information is also consumed by other process elements. Multiple users, each with distinct needs and purposes, actively seek packets of information that are collected from the many sources. But regardless of the intended use, once armed with the information, users can make informed decisions based on a firm foundation of data.

Sources of Information	Users of Information
<ul style="list-style-type: none"> <li>• Operators</li> <li>• Pieces of process machinery</li> <li>• Product designs</li> <li>• Purchased components</li> <li>• Process designs</li> <li>• Production Schedules</li> <li>• Resource Allocations</li> </ul>	<ul style="list-style-type: none"> <li>• Operators</li> <li>• Pieces of process machinery</li> <li>• Process Supervisors</li> <li>• Process Schedulers</li> <li>• Engineers</li> <li>• Managers</li> <li>• Equipment Designers</li> <li>• Material Handlers</li> <li>• Operation Analysts</li> <li>• Quality Assurance Personnel</li> <li>• Financial Analysts</li> <li>• Industry Regulators</li> </ul>

**Table 4: Some of the Many Sources and Users of Information in Factory Production Systems<sup>81</sup>**

The task of actually linking each information source with every information use is usually extremely complex and takes significant effort. However, the establishment of the “web of information” enables the firm to take advantage of information in ways never before possible.

“The future realization of an information infrastructure will transform the handling of information and the productivity and [innovativeness] in companies and society as much as the connection to water, transportation, and energy infrastructures have done in the past for households, manufacturing, and distribution.”<sup>82</sup>

By harnessing the power of this information, the firm can realize multiple benefits at strategic, operational and tactical levels. When combined together, they can be exploited to give the firm a powerful advantage.

“The management of information in this [business] environment can provide a major global competitive edge to the company that can achieve the optimal integration of that information with technology, with the

<sup>81</sup> Integrated Process Design and Development, Dan L. Shunk, Business One Irwin, Homewood, Illinois, USA 1992, Page 202.

<sup>82</sup> Information Infrastructure Systems For Manufacturing: Proceedings of the IFIP TC5/WG5.3/WG5.7 International Conference on the Design of Information Infrastructure Systems For Manufacturing, DIISM 1996, Jan Goossenaerts (Editor), Chapman & Hall, London, 1996, Introduction.

experience and knowledge of the people, and with the full communication links between the enterprise and its customers and suppliers.”<sup>83</sup>

The success of several corporations in recent years (such as Dell and Cisco Systems) can be traced back to the leveraging of their information systems, both within their internal functional groups as well as between their external partners.

“Information infrastructure systems are anticipated to offer services enabling and catalyzing the strategies of manufacturing companies responding to...challenges: they support the formation of extended enterprises, the mastering of full product and process life cycles, and the digitalization of the development process. Information infrastructure systems would accommodate access to and information as required by the various authorized stakeholders involved in the life phases of products or production resources. Services should be able to select and present all relevant information for situations involving any kind of players, during any life phase of a product or artifact, at any moment and at any place.”<sup>84</sup>

While there is much debate over the level of investment and technology required to take full advantage of these benefits, there is no doubt that the migration towards an information-driven organization yields multiple rewards for the firm.

### Strategic Benefits

On a strategic level, the presence and mastery of a formal information system is becoming a business necessity in most industries, due to the continual shift towards specialization and segmentation of the value chain. While the division of components between firms can lead to greater optimization of the entire value chain, each additional link in the chain can dramatically increase the level of coordination required to ensure that all interests of all firms are properly aligned. A structured information system can minimize the coordination efforts by facilitating communication between the groups and by providing methods of monitoring the actions of parties in the value chain.

“Information Technology and the emergence of a powerful global information infrastructure enable manufacturing industries...to develop collaborative partnerships across the value chain. Successful collaboration is achieved by the sharing of information at all phases of

---

<sup>83</sup> Integrated Process Design and Development, Dan L. Shunk, Business One Irwin, Homewood, Illinois, USA 1992, Page 2.

<sup>84</sup> Information Infrastructure Systems For Manufacturing: Proceedings of the IFIP TC5/WG5.3/WG5.7 International Conference on the Design of Information Infrastructure Systems For Manufacturing, DIISM 1996, Jan Goossenaerts (Editor), Chapman & Hall, London, 1996, Introduction.

the business cycle, across the supply chain and across national and international boundaries.”<sup>85</sup>

Therefore, as value chains become even more complex and international, a formalized information system is needed to facilitate information flow between a firm and its partners.

Looking internally, an additional strategic need for a comprehensive information system arises from the continually increasing complexity of manufacturing systems. Traditional management systems have proved inadequate for the control of these advanced systems. What is needed is an overall integrated information system that reaches all areas of an enterprise.<sup>86</sup>

### Operational Benefits

On an operational level, the firm can realize numerous benefits through the use of an integrated information system. By gathering specific knowledge about a manufacturing process, a design team raises their understanding of the fundamental behavior of that process and discovers the key factors that influence the ultimate performance of the production system.

“Collecting and classifying production data is a useful task in itself and is well within the reach of even a medium-sized business. Leaving aside ambitious projects that require high levels of investment, the reorganization of procedures and the redefinition of data paths yield immediate benefits and open up future opportunities for any company.”<sup>87</sup>

Just by implementing a basic information system that collects and organizes process data increases awareness and allows identification of multiple areas where the overall efficiency of the process can be improved. By implementing an advanced information system, the firm realizes even more operational benefits.

“The pace of work in a modern factory is set by the decisions made to deal with unforeseen circumstances. Machine-tool failures, late supplies, and staggered strikes are all recurring problems in day-to-day operations, which the organization must learn to tackle and overcome with the least damage. This means that the factory must develop its own “nervous system” to identify problems timely and to free managers from the most routine tasks, allowing them to focus their attention on the key factors for efficiency. Shop-floor control techniques were invented to achieve these aims. They highlight bottlenecks in production flow and indicate the most appropriate ways to eliminate them. The result is better use of resources without longer lead times, a very real benefit for the gross

---

<sup>85</sup> IT and Manufacturing Partnerships: Delivering the Promise – Proceedings of the Conference on Integration in Manufacturing, Galway, Ireland, October 204, 1996, J. Browne, R. Haendler Mas, and O. Hlodversson (Editors), IOS Press, Amsterdam, The Netherlands, 1997, Foreword.

<sup>86</sup> Ibid, Page 6.

<sup>87</sup> Manufacturing Information Systems, Luca G. Sartori, Addison-Wesley Publishing Company, Wokingham, England, United Kingdom, 1988, Page 2.

output of the company, which grows even with the same production facilities. Investing in a manufacturing information system is like acquiring new capacity in the most suitable mix to satisfy outstanding customer orders.”<sup>88</sup>

Therefore, an advanced information system enables better use of the firm’s manufacturing resources, increasing operational performance.

#### Tactical Benefits

Finally, on a tactical level, the use of an integrated information system permits a firm to increase the productivity of its associated process.<sup>89</sup> From a time standpoint, a formalized flow of information will reduce the overall time required to perform engineering functions once a job hits the shop floor. By properly specifying what parts are needed, when they are needed, where those parts are needed and how many parts are needed, orders will not have to be revised to include additional information.

In addition to reducing engineering work, there should be a reduction in manufacturing rework, since operators will clearly know all details that are associated with an order. Still more time will be saved due to the elimination of the time needed to enter the same data into multiple systems.<sup>90</sup> Because the information system can automate many of the process’ low-level tasks, operators are now freed up to perform other, more value-added tasks, simultaneously increasing the utilization of factory equipment and improving the response time of the factory.

From a quality improvement standpoint, the systematic flow of information will ensure that process operators have all information that they require to perform their task. This will ensure that the right parts (in the correct quantity and sequence) are produced at delivered at the appropriate time. As a result, there will be a greater percentage of products produced right the first time, a reduction in the number of scrapped parts, and therefore and overall increase in the quality of end products. The savings in time and improvements in quality will directly lead to overall cost reductions.

#### The Increasing Importance of Information

Therefore, the use of a formalized information system produces numerous benefits to a firm. Some firms have successfully exploited these benefits and have created a significant competitive advantage in their industries. Other firms have used an information system to simply raise their awareness of the fundamental behavior of their manufacturing processes. However, regardless of how a firm uses their

---

<sup>88</sup> Ibid, Page 113.

<sup>89</sup> “Perspectives on Manufacturing Engineering Software Integration”, C.R. McLean, Information Infrastructure Systems For Manufacturing: Proceedings of the IFIP TC5/WG5.3/WG5.7 International Conference on the Design of Information Infrastructure Systems For Manufacturing, DIISM 1996, Jan Goossenaerts (Editor), Chapman & Hall, London, 1996, Page 22.

<sup>90</sup> Manufacturing Databases and Computer Integrated Systems, Dimitris N. Chorafas, CRC Press, Boca Raton, Florida, USA, 1993, Page 9.

information system, it is vital that a firm does implement a formal system to flow information. Not doing so will result in that firm being surpassed by its competitors.

As important as the use of information systems has become, it is expected that their importance will continue to increase, and do so at an increasing rate.

“The availability of ever more powerful and inexpensive computers has permanently changed the way we do business. This trend will certainly continue. Indeed, computer technology and the system options that it permits will soon dominate the information aspects of manufacturing.”<sup>91</sup>

“As computers worldwide get connected in a global network and industries move towards an extended enterprise mode of production and development and learn to cope with the full life cycle of goods and artifacts, it is expected that information infrastructure services will play an increasing role for the exchange of technical and business data, and for the distributed development and control of business processes.”<sup>92</sup>

This is due to the continual technological and performance improvements that are made in computer systems. These advancements have opened the doors to productivity improvements that were not even thought of even a short time ago. Now, “even the most daring projects become feasible, losses and waste can be eliminated, and existing assets are freed for new investments. The time is not far off when manufacturing will become a post-industrial reality and will reap the benefits that computer science is bringing to all other corporate functions.”<sup>93</sup>

“Progress...in information technology is providing exciting opportunities for improving the ways in which manufacturing activities are monitored, managed and integrated into the other associated functions required to support a business enterprise. For example, there are the computer’s capacity to accurately capture, record, manipulate and display data, the capability for high-speed transference of information between computer systems, and the ability, using microprocessor engineering, to consistently and precisely control machinery and materials flows. These give significant means to improve the overall efficiency of a complex organization and to maintain up-to-date knowledge of the states of its constituent parts.”<sup>94</sup>

---

<sup>91</sup> Integrated Process Design and Development, Dan L. Shunk, Business One Irwin, Homewood, Illinois, USA 1992, Preface.

<sup>92</sup> “A Framework For Connecting Work and Information Infrastructure”, J. Goossenaerts, Information Infrastructure Systems For Manufacturing: Proceedings of the IFIP TC5/WG5.3/WG5.7 International Conference on the Design of Information Infrastructure Systems For Manufacturing, DIISM 1996, Jan Goossenaerts (Editor), Chapman & Hall, London, 1996, Page 193.

<sup>93</sup> Manufacturing Information Systems, Luca G. Sartori, Addison-Wesley Publishing Company, Wokingham, England, United Kingdom, 1988, Page 1.

<sup>94</sup> Integration and Management of Technology For Manufacturing, E.H. Robson, H.M. Ryan, and D. Wilcock (Editors), Peter Peregrinus, Ltd., London, England, United Kingdom, 1991, Page 3.



Therefore, as important as information has become in the manufacturing arena, and as it is expected to continually become the focal point of advanced manufacturing processes, it is clear that a firm must move to develop and implement an information system in all of its processes.

### **The Islands Of Automation**

#### Description

Many firms worldwide have already recognized the power of information, and these firms use the power to continually improve overall productivity and performance of many production systems. The numerous benefits obtained have caused businesses to realign their processes to maximize the collection and the availability of information throughout their firm. However, even though firms have embraced information, the typical application of information systems in those firms has not been uniform.

In a typical firm, some process elements use advanced information systems for the recording and analysis of vital process and product performance data. But other process elements remain as they were originally designed, failing to make use of the informational elements that are available. Because of this, there are usually some highly advanced process elements that become are information rich, but other elements that have no links whatsoever to process information. Very little sharing of information occurs between these stations, thereby reducing the overall effectiveness of the information system.

The attempts to improve the use of information at select points in a manufacturing system are similar to improving the process performance of a non-bottleneck operation. Unless the speed of the overall system is increased, changing individual stations will only have limited effects. This is shown in Figure 21. The flow through the system (pipe) will not be increased, even if the flow rates of individual sections of that pipe are increased.

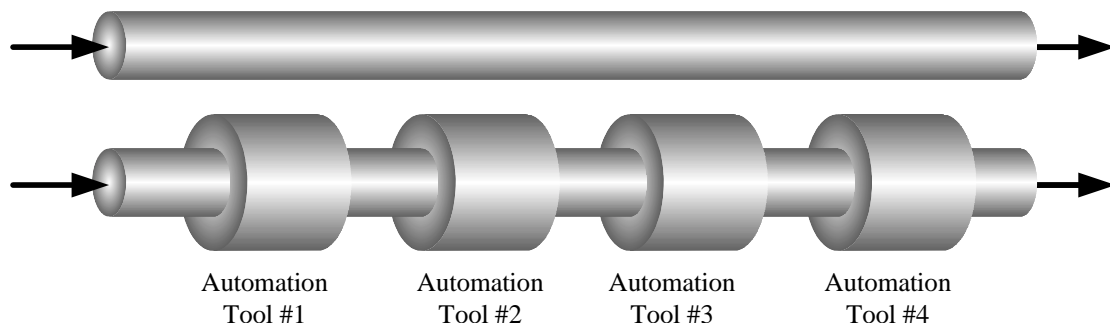

**Figure 21: Increasing Local Flow Rates Will Not Increase the Total System's Flow Rate<sup>95</sup>**

---

<sup>95</sup> "UK Manufacturing: The Challenge Of Transformation", C.C. New, Integration and Management of Technology For Manufacturing, E.H. Robson, H.M. Ryan, and D. Wilcock (Editors), Peter Peregrinus, Ltd., London, England, United Kingdom, 1991, Page 107.

This behavior is not limited to pieces of manufacturing equipment on an assembly line. In addition to the manufacturing process elements, there are also disconnects between functional organizations, such as the long-standing division between design and manufacturing.

“Design and manufacturing system applications are being implemented at an increasing rate. Yet very little success has been achieved through the integration of CAD and CAM in some of these installations because of the lack of consistency (rigor), the lack of metrics, and the inability of the factory floor to be adequately reflected in the transition from the planning to the control of the execution phases. Many of the barriers between design and manufacturing exist as they have since the beginning of the Industrial Revolution.”<sup>96</sup>

“At least three types of data sets are frequently used in an industrial enterprise. One data set is used in the CAD environment, another in process planning, and a third for manufacturing. All three of these are supposed to describe the same object independently. Unfortunately, these data sets are frequently overlapping and incomplete. Only a few companies had been able to achieve a level of integration that allows the use of a single data set.”<sup>97</sup>

Even though the information flow within these groups has been greatly improved through the introduction of specialized tools, overall flow through the entire system is not affected unless the specialized tools are seamlessly integrated between all groups

Often, it is the software applications themselves, which were originally designed to take advantage of the power of information, which have ultimately contributed even more to the problem of isolation.

“A recent NIST study of engineering tools has identified more than 400 engineering software products marketed today, most all of which are virtually incompatible with one another. That is, interoperability between these tools is for the most part, non-existent.”<sup>98</sup>

This issue of disconnection of information between different process elements is present in numerous manufacturing systems as well as other areas of most modern firms. This major problem, commonly referred to as “Islands of Automation”, can be visualized as shown in Figure 22.

---

<sup>96</sup> Integrated Process Design and Development, Dan L. Shunk, Business One Irwin, Homewood, Illinois, USA 1992, Page 185.

<sup>97</sup> “Designing An Information System For Integrated Manufacturing Systems”, Ulrich Flatau, Design And Analysis of Integrated Manufacturing Systems, Ulrich Flatau (Editor), National Academy Press, Washington, DC, 1988., Page 61.

<sup>98</sup> “Perspectives on Manufacturing Engineering Software Integration”, C.R. McLean, Information Infrastructure Systems For Manufacturing: Proceedings of the IFIP TC5/WG5.3/WG5.7 International Conference on the Design of Information Infrastructure Systems For Manufacturing, DIISM 1996, Jan Goossenaerts (Editor), Chapman & Hall, London, 1996, Page 21.

The “Islands” represent different process elements in a manufacturing system, or functions of a greater organization. While many of the “Islands” have highly developed infrastructures of their own, there is often little communication between the “Islands”. In order for different process elements to communicate, cumbersome steps are needed. But sometimes, even using complicated efforts, communication between the elements cannot be achieved at all.

In many cases, significant efforts have gone into building links between the “Islands” to allow the sharing of information. Some links have agreed upon communication standards, frequencies, and protocols and can be best represented as solid bridges. Using these links, data can easily be transferred, with minimal effort. Other links are slightly less permanent, occurring only at specified times (ferry boat) or occurring when needed (charter flight). Other links are extremely primitive, and have extreme risks (high wires) or constraints (stepping-stones that can only be crossed at low tide). Of course, many process elements aren’t linked at all.

#### The Causes of the Islands Of Automation

Much of the creation of the “Islands” can be directed attributed to the evolution of information systems themselves. New information technologies are constantly being developed, each solution bringing new benefits to the overall information system. In many manufacturing systems, there is a large age range of the pieces of equipment, as well as a range in their sophistication of technology. When a specific piece of equipment was designed, the informational systems that were modern at that time were incorporated into that machine’s control system. However, no accommodation was made for the updating of control or information systems as technology advanced.

“Many of the current problems associated with planning an IT strategy arise because of the fragmented manner in which information technology has developed. Originally, data processing techniques were seen as providing individual solutions to individual problems. Some linking of separate tasks took place, but usually the whole process remained contained within the walls of the computer room and the technology had little visibility to management. Then the (cheaper) microcomputer made computing available to all and many small (non-compatible) applications emerged. Computer networks began to expand initially to service single applications from many points and later to provide the capability for remote processing on satellite computers and personal workstations.

On the factory floor, numerically controlled machine tools increased in number and some linking into ‘cells’ took place. These developments are aptly described as ‘Islands of Automation’.

As this evolution progressed, management became concerned about the ever-increasing expenditure without an overall plan. Whilst each proposal carried its own cost/benefit analysis, they each gave only a

small incremental improvement without any major effects on the real 'competitive edge' problems being faced by the company overall.”<sup>99</sup>

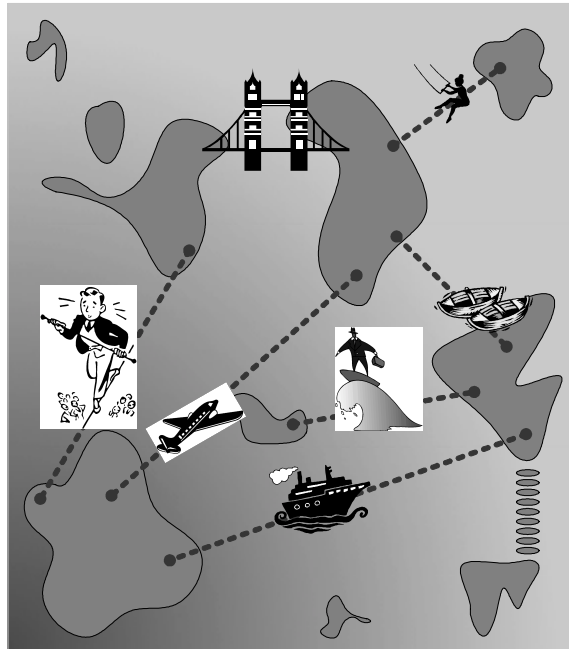

**Figure 22: The Islands Of Automation<sup>100</sup>**

Thus, since an overall information system strategy had never been developed, improvements to the information system were implemented on a piece-meal basis. Each step only brought marginal improvements in overall performance, yet greatly multiplied the overall complexity of the system.

An additional cause of the “Islands” is the complex nature of manufacturing systems themselves. Because of the intricacy, information systems must often be custom designed for each and every process.

“Manufacturing systems often operate in complex environments, rife with uncertainty. The complexity arises from novelty of tasks/events, nonlinearities, and a multitude of interactions that arise when attempting to control various activities in dynamic shop floors. This complexity and

---

<sup>99</sup> “Implementing An IT Strategy In A Manufacturing Company”, H.S. Woodgate, Integration And Management Of Technology For Manufacturing, Edited by E.H. Robson, H/M/ Ryan & D. Wilcock, Peter Peregrinus Ltd., London, UK, 1991, Page 159.

<sup>100</sup> “Interfacing Technology for Manufacturing Industry: From Islands of Automation to Continents of Standardisation and beyond”, Nigel Shaw, Interfaces In Industrial Systems For Production and Engineering: Proceedings of the IFIP TC5/WG5.10 Working Conference on Interfaces in Industrial Systems for Production and Engineering, Darmstadt, Germany, March 15-17, 1993, J. Rix and E.G. Schlechtendahl (Editors), Elsevier Science Publishers, B.V., Amsterdam, The Netherlands, 1993, Page 2.

the uncertainties limit the effectiveness of conventional control and scheduling approaches.”<sup>101</sup>

Usually, the simplest way to deal with this complexity was to develop a small application that is simple and easily understood and which address the needs of a specific process element. But every time this occurs, a new “island” is created, increasing the overall complexity of the system in the long run.

A final cause of the “Islands” must be attributed to the common use of multiple equipment vendors in the construction of a manufacturing process. When this practice is used, machine vendors will implement their own (usually proprietary and incompatible) information system.<sup>102</sup> Integration between different process elements becomes complex and requires significant effort. Traditionally, as the pressure to launch a process builds, it became easier for process designers to accommodate the individual information system, even though it may be incompatible with other system. It was assumed that the construction of the links between the different systems would be straightforward, once the process was launched and operational. This assumption was ultimately wrong.

#### The Consequences of the Islands Of Automation

The creation and presence of the “Islands Of Automation” have severe consequences. First, “Islands of Automation” are financially damaging, since the effort and resources required to build links between different systems are much greater once the individual systems have been designed and implemented. Incompatible standards, different data structures, as well as different technology platforms require process designers to develop complicated translation utilities to build a link between the systems. Had the interface for the two systems been agreed upon at the early stages of design, it would have been resulted in a simpler, and less expensive, implementation.

Next, even if a link between two different systems was specified early, that link may have to be completely redesigned if it proved incompatible with other process elements. To add just one new process element could require significant modifications to all existing links, if that new element’s system conflicts with other current systems. Thus, a tremendous amount of rework could be involved in the construction of a system-wide information system, if standardized links are not originally developed at the beginning of the process design stages.

---

<sup>101</sup> “Knowledge based reactive management of manufacturing cells”, B. Kadar, S. Markos, & L. Monostori, IT and Manufacturing Partnerships: Delivering the Promise – Proceedings of the Conference on Integration in Manufacturing, Galway, Ireland, October 204, 1996, J. Browne, R. Haendler Mas, and O. Hlodversson (Editors), IOS Press, Amsterdam, The Netherlands, 1997, Page 197.

<sup>102</sup> “Designing An Information System For Integrated Manufacturing Systems”, Ulrich Flatau, Design And Analysis of Integrated Manufacturing Systems, Ulrich Flatau (Editor), National Academy Press, Washington, DC, 1988., Page 63.

Not only is the construction of information links after a process has been launched extremely expensive to develop, but it also introduces unneeded complexity and confusion. Rather than having to simply understand the network of links between process elements, the user must now understand how each and every process element accesses those links. The user will have to now know whether a link is a “bridge” or a “high wire” rather than simply knowing that a reliable link between the systems exists.

Finally, if different process elements have to access and use the same information, but these elements are not linked, each station will have to collect and manage its own set of data. The maintenance of two sets of the same information leads to problems associated with redundant, missing, or conflicting data. Not only are extra resources required to collect this data, but also other resources will be needed to resolve the inevitable inconsistencies in the data.

#### To Overcome the Islands Of Automation

It is clear that the “Islands Of Automation” is a major issue confronting manufacturing firms. So, what steps can be taken to eliminate these “Islands” and achieve a highly linked and efficient network that allows for expansion and upgrading of informational technology? The answer lies in modifying the design methodologies used to develop the manufacturing system. Only by considering the flow of information as a vital component of the design of a manufacturing process will a firm prevent the damaging effects of the “Islands.”

“A key issue of the 1990’s is the ability for world class manufacturing enterprises to handle their information in a structured and controlled manner. Ad-hoc approaches to the design and maintenance of information systems need to be replaced by a more controlled and flexible ones. In addition an ability to readily respond to changes in information needs of the enterprise is required.”<sup>103</sup>

“Partial automation of the manufacturing process is no longer enough to ensure that a company remains competitive.... So, what is the alternative? It seems that the conclusion has to be improve, indeed, to optimize, the flow of information as well as the flow of material. Process improvement is essential and many gains are to be made through better used of information.”<sup>104</sup>

---

<sup>103</sup> “A Model Based Approach to Enterprise Wide Information Support”, P.E. Clements, I.A. Coutts & J.M. Edwards, Information Infrastructure Systems For Manufacturing: Proceedings of the IFIP TC5/WG5.3/WG5.7 International Conference on the Design of Information Infrastructure Systems For Manufacturing, DIISM 1996, Jan Goossenaerts (Editor), Chapman & Hall, London, 1996, Page 170.

<sup>104</sup> “Interfacing Technology for Manufacturing Industry: From Islands of Automation to Continents of Standardisation and beyond”, Nigel Shaw, Interfaces In Industrial Systems For Production and Engineering: Proceedings of the IFIP TC5/WG5.10 Working Conference on Interfaces in Industrial Systems for Production and Engineering, Darmstadt, Germany, March 15-17, 1993, J. Rix and E.G. Schlechtendahl (Editors), Elsevier Science Publishers, B.V., Amsterdam, The Netherlands, 1993, Page 2.

An overall systems approach is needed towards process design. Rather than concentrating on improving the performance of specific process elements, this approach must focus upon the entire system.

In addition, this overall systems approach must involve multiple parties, such as equipment vendors, product engineers, and program management. Tools must be implemented to bring all of these diverse viewpoints and interests together, in order to gather all input necessary to design optimal physical flow and informational flow systems.

“A successful engineering information management strategy must be able to integrate information in a number of different formats, from a number of sources, and allow personnel easy, and controlled access to the required information. In addition the integrity of the information must be maintained by the implementation of suitable change control, and associated security measures. Traditional computer- or paper-based systems which present and distribute text and engineering drawings sequentially can no longer be considered adequate.”<sup>105</sup>

“It should be clear that integration requires a great deal of system planning. As an ongoing process, it requires a long-term commitment from high-level management, political unity and coordination of all elements in the enterprise, and, finally, strict discipline in function, data, and process definition. System integration requires some of the same approaches required in the building of a house. For example, serious construction on a house would not be started without a plan. Although such a sequence of events would not be expected to occur in computer-integrated manufacturing systems, systems continue to be started without a clear plan having been developed for the integration. All too often a detailed plan is replaced with a hope that somehow, sometime, all the disconnected pieces will come together to make a highly effective system. What must be made clear is that there are too many different technologies, functions, and requirements in such a system to be left to chance. It will not work effectively without a plan and the commitment from all who are involved.”<sup>106</sup>

In addition to taking an overall systems approach and involving all parties in the design of the information system, the design team must make significant efforts to reduce the overall complexity of the information system. It is only through reviewing the current design concept and reducing its overall complexity that the team can ensure the ultimate complexity of the production system will be minimized, enabling better production performance and overall understanding of the production system.

---

<sup>105</sup> “Industrial Information Resource Management”, Richard Crowder & Wendy Hall, IT and Manufacturing Partnerships: Delivering the Promise – Proceedings of the Conference on Integration in Manufacturing, Galway, Ireland, October 204, 1996, J. Browne, R. Haendler Mas, and O. Hlodversson (Editors), IOS Press, Amsterdam, The Netherlands, 1997, Page 206.

<sup>106</sup> “Designing An Information System For Integrated Manufacturing Systems”, Ulrich Flatau, Design And Analysis of Integrated Manufacturing Systems, Ulrich Flatau (Editor), National Academy Press, Washington, DC, 1988, Page 66.

By focusing on information systems design, firms can move from their current position of complex information systems controlling complex physical systems to the preferred position of simple information systems controlling simple physical systems. “The complexity of CIM [Computer Integrated Manufacturing] is a direct function of the simplicity of the operation. And the complexity of CIM is indirectly proportional to its chance of success.”<sup>107</sup>

“Simplification is fundamental to the overall success of the system. Heretofore, engineers have prided themselves that on the ability to design complex systems that required sophisticated tooling, sophisticated fixturing, sophisticated controls, and sophisticated management systems to perform the operation properly. This pride of creation has yielded very, very complex systems, and the cost-effectiveness of these complex systems is being questioned. The model for the 21<sup>st</sup> century appears to be one of simplification first, followed by integration, and, ultimately, automation.”<sup>108</sup>

The team should look for opportunities to consolidate neighboring process steps, or eliminate process steps altogether, while still maintaining or improving the overall simplicity of the process. Only after this point should the team seek to integrate process steps and link them with information system automation, if integration still makes sense.<sup>109</sup>

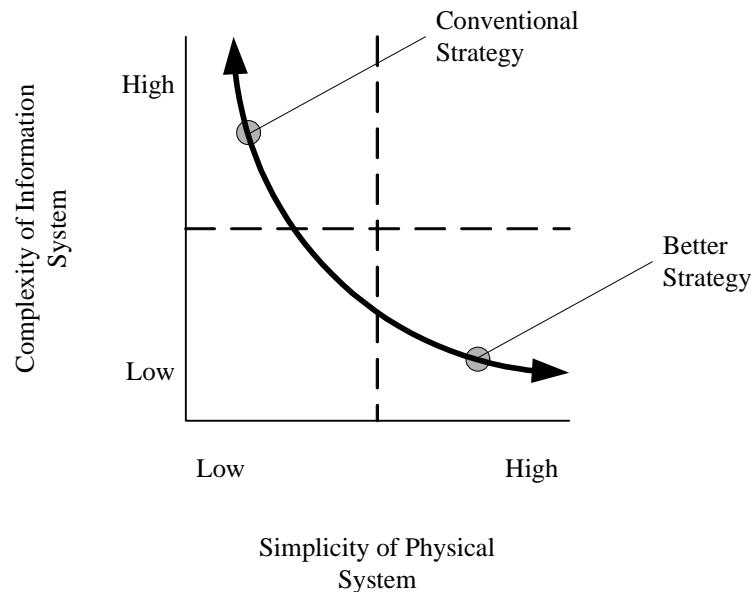

<sup>107</sup> “Simplification Before Automation”, Hal Mather, Integration and Management of Technology For Manufacturing, E.H. Robson, H.M. Ryan, and D. Wilcock (Editors), Peter Peregrinus, Ltd., London, England, United Kingdom, 1991, Page 9.

<sup>108</sup> Integrated Process Design and Development, Dan L. Shunk, Business One Irwin, Homewood, Illinois, USA 1992, Page 69.

<sup>109</sup> Integrated Process Design and Development, Dan L. Shunk, Business One Irwin, Homewood, Illinois, USA 1992, Page 37.



### **Figure 23: Simplify The Physical System Rather Than Automate Complex System<sup>110</sup>**

The design team must not only seek to simplify the design of the manufacturing system itself, but also the data that is being collected. Because of the modern computers' capability to monitor and store incredible amounts of information, there is a natural tendency to record as much data as possible. The feeling is that engineers can analyze the data to find systematic problems. However, having reams of data is almost as ineffective as having no data. By recording every piece of information possible, engineers quickly become overwhelmed in the analysis of the data. Critical process metrics become lost in a sea of information, thereby preventing engineers from clearly seeing what is happening. To avoid this, the design team must determine what pieces of information are vital to the process, and which pieces do nothing but confuse the overall situation.

In conclusion, the process design team should first seek to simplify all processes, before they seek to implement an information system to manage or automate the process.<sup>111</sup> A company must initially compete based on the strength of its processes, not of its information system.<sup>112</sup> Any competitive advantage subsequently obtained through automation can only be achieved after simplification, and complete understanding and perfection of the underlying business processes.<sup>113</sup>

This thesis will now present several design techniques that can be used to capture these requirements for the overall system. The result will be a process design methodology that is built upon traditional process design methods. Several of the principle tools in that process (Physical Flow Chart, Physical Flow Relationship Chart, and Physical Flow Block Layout Diagram) will be modified to enable the consideration of informational aspects of a manufacturing system. These new tools will then be combined with the traditional design methodology to result in a process that will enable concurrent design of a physical and an informational system in a manufacturing setting.

#### **The Modeling of Information**

---

<sup>110</sup> Integration and Management of Technology For Manufacturing, E.H. Robson, H.M. Ryan, and D. Wilcock (Editors), Peter Peregrinus, Ltd., London, England, United Kingdom, 1991, Page 10.

<sup>111</sup> "Simplification Before Automation", Hal Mather, Integration and Management of Technology For Manufacturing, E.H. Robson, H.M. Ryan, and D. Wilcock (Editors), Peter Peregrinus, Ltd., London, England, United Kingdom, 1991, Page 5.

<sup>112</sup> "Changes in the Industrial Environment and CALS", L. Zuijggeest, Information Infrastructure Systems For Manufacturing: Proceedings of the IFIP TC5/WG5.3/WG5.7 International Conference on the Design of Information Infrastructure Systems For Manufacturing, DIISM 1996, Jan Goossenaerts (Editor), Chapman & Hall, London, 1996, Page 19.

<sup>113</sup> "Simplification Before Automation", Hal Mather, Integration and Management of Technology For Manufacturing, E.H. Robson, H.M. Ryan, and D. Wilcock (Editors), Peter Peregrinus, Ltd., London, England, United Kingdom, 1991, Page 10.

It has been shown that harnessing the power of information is a necessity of a firm to remain competitive in today's complex manufacturing environment. Information allows objective decision-making, in-depth process performance analysis, and simulation of hypothetical situations. Firms that have aligned their manufacturing processes to take advantage of the information that is available have found success and leadership positions in their respective industries. Other firms that have ignored the effective use of information have had less successful experiences.

It has also been shown that many firms recognize the importance of information, but only come to that realization after manufacturing processes had been launched. Firms then try to implement adequate information systems on top of pre-existing processes, adding components to the system where necessary. However, these piecemeal systems have only led to marginal results, often only adding more complexity, costs, and confusion.

What is needed therefore is a complete reconsideration of a manufacturing process' design. During this design project, the team must consider the design of the information system as well as the design of the physical system. By doing so, the design team will develop a fully integrated system that optimizes the flow of information as well as the flow of physical material.

To develop an optimal design of an information system for a manufacturing production line, a formal design process must be used. Fortunately, many of the techniques used to model and design a physical flow system can be used to design the information system. This is due to the fact "information" can be treated as a discrete physical part, that is processed through the production line.

While this may seem unconventional, this abstraction is firmly based on reasonable logic. Later sections will demonstrate how individual process elements in a physical production system (such as a storage element) have direct complements in an informational production system. However, beyond the central process elements, there are also other many behavioral elements of an information system that are closely related to a physical system.

Consider the commonly understood notion of a process bottleneck. In simplest terms, a process bottleneck is "any resource whose capacity is equal to, or less than the demand placed on it."<sup>114</sup> Even if upstream and downstream process elements are operated at high speeds, the ultimate output of a process can never exceed that of the process bottleneck. Because of this, a core technique of process designers is to locate and eliminate process bottlenecks in order to improve the flow of parts through the system.

---

<sup>114</sup> "Lean Manufacturing Glossary", [SearchManufacturing.com](http://www.searchmanufacturing.com) (<http://www.searchmanufacturing.com/Manufacturing/Lean/glossary.htm>), Ruth Ellen Carey Communications, White Lake, Michigan, USA, April 7, 2003.

Now, consider the flow of information through a system. In any system, there is likely to be a point where the transfer of information is being held up. Downstream processes have to wait for information to flow through the bottleneck and upstream processes must wait until the information bottleneck is free to receive more information. The resulting degradation of performance can be completely attributed to the reduced flow of information. This then points to the notion that process designers should seek to locate and eliminate information flow bottlenecks as eagerly as they look for physical flow bottlenecks.

Next, consider parallel versus serial processing of physical parts. In a serial system, each individual process is linked only to one upstream station and one downstream station, creating only one path for parts to take through the production system. However, in a parallel system, each individual process is replicated, so parts may be received from and in turn sent to any of a number of stations. The result is that more parts can be processed through the parallel system, since the flow of parts is not constrained by the output of one process element.

Looking at the flow of information, the improved performance of parallel systems can also be observed. Indeed, the entire backbone of the Internet is dependent upon this concept. Should one Internet server or router become blocked or faulty, information is simply rerouted to the destination via another route. Therefore the flow of information through each node of the Internet is not dependent upon the flow rate of its upstream or downstream nodes. This notion shows process designers that a certain amount of redundancy in both physical and informational flow systems is ideal, since it acts to isolate the flow from process constraints.

Next, examine the similarities related to storage of physical parts and storage of information. In a physical system, parts are stored mainly to ensure that when those parts are needed by downstream operations, they will be available. In a similar manner, information is stored to enable processing at a later time. For example, the storage of information allows for the review a product's routing through a production system, the analysis of a product's test and calibration performance, or a listing of all components that have been installed in a product during an assembly process. Thus, the notion of an "information buffer" makes perfect sense in considering the design of an information system.

Finally, consider how blocked and starved conditions can cascade through both physical flow and informational flow processes. Minor stoppages at one station prevent upstream operations from beginning work on their next part, since the stopped station is not available to receive the part that has just been completed. In addition, the station downstream of the stopped operation has to wait for the upstream operation to complete its work and send that part downstream. These situations quickly replicate through

the other stations so that, if the stoppage is long enough, all stations are either waiting for parts or cannot begin work on the next part until their current part can be released downstream.

This behavior occurs not only in physical systems, but also in informational systems. For example, a minor delay in the processing of a purchase order through a department can cause downstream operations (i.e. invoicing, payment, etc.) to run out of work to perform. Upstream operations (i.e. system specification, product design, etc.) cannot process with the next purchase order until the current order is completely processed. Thus, not only do blocked and starved conditions exist and proliferate in physical flow systems, but they also occur in informational flow systems.

These elements demonstrate that informational and physical flow can be modeled and treated in a similar manner. Thus, the tools developed to design a production process based on physical flow can be adapted to consider informational flow. The following sections will examine how the **Physical Flow Chart**, the **Physical Flow Relationship Chart**, and the **Physical Flow Block Layout Diagram** can be adapted to consider information flow. These adapted tools will then become part of an enhanced process design methodology, which supports the concurrent design of informational flow and physical flow manufacturing systems.

### **An Informational Flow Chart: The Fourth Foundational Element**

Earlier, the Physical Flow Chart was described as a major element of used in manufacturing process design. In the early stages of a project, the process designer develops a Physical Flow Chart in order to understand the sequences of steps involved in the manufacturing of a product. The purpose of the Physical Flow Chart was to graphically represent the sequence of all operations, transportations, inspections, delays, and storages of physical material occurring during a process.

The Physical Flow Chart only needs to be slightly modified to show the sequence of all operations, transportations, delays, and storages of information and communication in a manufacturing process. Both “information” and “communication” can be treated as actual materials that are flowed through a production system in a similar manner as a physical part.

Previously, the definitions for common physical process elements were given. For each of these elements, a direct counterpart can be identified in the flow of information through an information production system:

- **Operation:** An operation process element occurs when information is intentionally changed in any of its characteristics, is assembled with or disassembled from other information, or is arranged for another operation, transportation, inspection, or storage. For example, the filling out of a data entry form is information operation.
- **Inspection:** An inspection process element occurs when information is examined and analyzed to verify any of its characteristics. For example, the querying of a SQL database is information inspection.

- **Transportation:** A transportation element occurs when information is moved from one place to another. For example, the emailing of production performance data from a supplier is information transportation.
- **Storage:** A storage process element occurs when information is kept and protected against unauthorized removal. For example, the archiving of encrypted financial data is information storage.
- **Delay:** A delay process element occurs when conditions do not permit or require immediate performance of the next planned action. For example, the batching of sales invoices prior to the generation of a quarterly sales report is information delay.
- **Deliver:** A deliver process element occurs when support information is brought to the start of a process or to any other intermediate process. For example, the supplying of certification and specification reports for a batch of incoming material is information delivery.
- **Route:** A route process element occurs when information has its downstream processing plan determined by decisions made at this process element. For example, if a functional test operation can use any of a number of computer processors to analyze test data, a route element will choose which resources on which system should be dedicated to the current part.
- **Ship:** A ship process element occurs when information is removed from the process after all processing has been completed. For example, the clearing of a gage's display after a measurement has been taken and recorded is the shipment of information.
- **Accumulate:** An accumulate process element occurs when carefully sequenced information is collected and mixed together so that the initial sequence is lost. For example, many operations record certain part characteristics, such as critical dimensions. However, sometimes these recordings do not properly specify necessary information (i.e. date, time, operator, etc.) required to adequately segment the data and maintain the proper sequence. Thus, the collection of this data loses the initial sequence of the tests.
- **Confound:** A confound process element occurs when negative factors cause the misidentification or improper processing of information. For example, if parts are tested using only pass/fail criteria, the underlying trend in the actual performance of the parts cannot be known. The use of variable data will make the information much more valuable, and will avoid such a confound element.
- **Interrupt:** An interrupt process element occurs when external factors cause one or more process elements to cease their normal production of information. For example, the interruption of a sequenced and automated test routine often requires test routines to be restarted, thereby delaying the output of the part under test.

Thus, each of the central process elements of a physical production system has a direct complement in an information production system, and each of those informational process elements have easily understood definitions and examples.

Using these basic elements, the team creates a symbolic representation of the process, showing the major informational elements of the process, what each process element does with information, and how information flows between each process element. To assist in the development of the Informational Flow Chart, input/output diagrams (that were developed when making the Physical Flow Chart) can be revisited to provide the design team with greater clarification of the exact role that information and communication play in how a specific process element relates to the entire production system.

In reality, the design team often finds that the communication paths in a process are much more complicated than the flow of physical parts. In addition, these flows are more complicated than can be shown on an Informational Flow Chart. To adequately show these flows, it is necessary to use the next tool of manufacturing system design, the Informational Flow Relationship Chart.

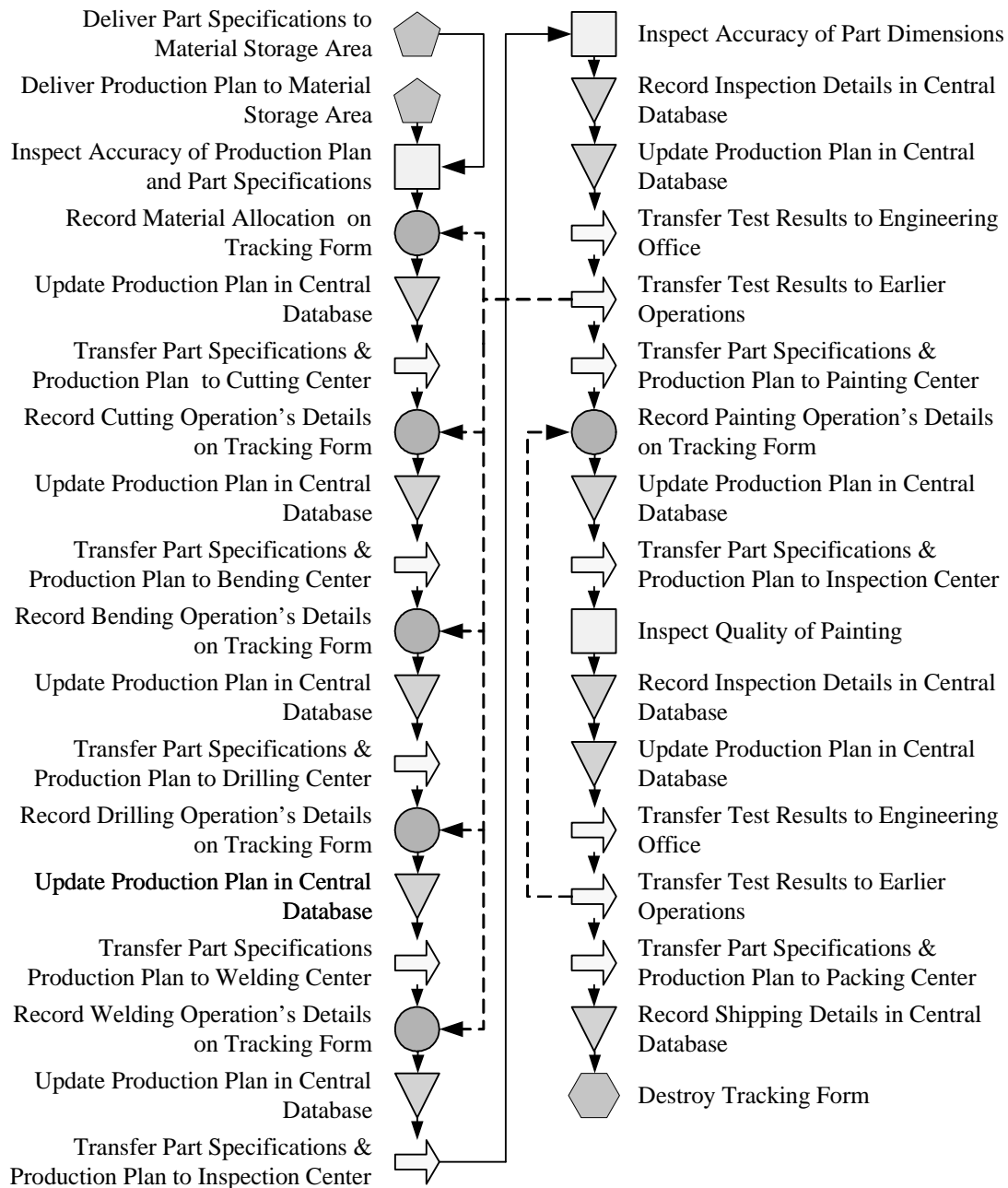

**Figure 24: Sample Informational Flow Chart**

**An Informational Flow Relationship Chart: The Fifth Foundational Element**

The Physical Flow Relationship Chart was shown to be an extremely powerful graphical tool that is used in the design of physical flow production systems. In a similar manner, an Informational Flow Relationship Chart is a valuable component for designing the informational flow system, and therefore it serves as the fifth major part in manufacturing process design.

The Informational Flow Relationship Chart allows the design team to recognize the underlying informational relationships between different process operations and functions as a graphical means of representing those informational links. By understanding and categorizing the informational flow relationships, the design team can develop an efficient information system that optimally links process elements depending on how frequently they share information. Those process elements that communicate continuously are given direct and robust connections, while less formal links are designed for those process elements that are not dependent on, or do not require, direct links to other process elements.

For each pair of process elements, the design team assigns a score based upon those elements' relationship. "Proximity Ratings" reflect the frequency or amount of information flow that occurs between two process elements. Links that have complicated or high volumes of information flow are given high Proximity Ratings while low Proximity Ratings designate low levels of communication. Table 3 shows a Proximity Rating system that can be used to populate Informational Flow Relationship Charts.

Proximity Rating	Description
A	<b>Absolutely necessary:</b> There is a high level of information flow, a high frequency of information flow, or other reasons make the continual communication between the two process elements absolutely necessary.
E	<b>Extremely important:</b> There is a moderate level of information flow, a moderate frequency of information flow, or other reasons make the continual communication between the two process elements extremely important.
I	<b>Important:</b> There are regular situations where it would be nice if process elements could directly communicate, but this is not vital. The transferring of information through an intermediate process element is undesirable, but can meet the needs of these elements.
O	<b>Ordinary:</b> There are occasional situations where it would be handy if process elements could directly communicate, but it is not vital. The transferring of information through an intermediate process element is sufficient.
U	<b>Unimportant:</b> It does not matter if the process elements can directly communicate or not. The entities do not directly share information. Any information flow that needs to occur between the two elements is passed through an intermediate process element.
X	<b>Undesirable:</b> It would be better if the process elements could not communicate directly.
Z	<b>Extremely undesirable:</b> It is dangerous if the process elements communicate directly. Or, it is likely to be highly disruptive to one

	communicate directly. Or, it is likely to be highly disruptive to one or both of the process elements if they communication occurs.
--	---

**Table 5: Proximity Ratings Used For Placement of Manufacturing Operations**

In addition to central process elements, the Chart also focuses on the relationships between process elements and any required auxiliary support systems, such as in-process part tracking, production scheduling, engineering change control, labor tracking, and supply chain management.

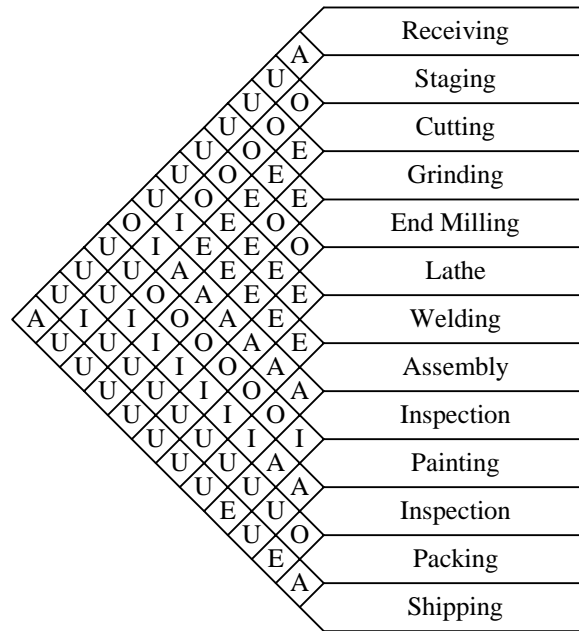

**Figure 25: A Sample Informational Flow Relationship Chart**

In creating an Informational Flow Relationship Chart, design teams will use many criteria to classify a process element. Often these criteria will have to be adjusted in relation to the type of information associated with a production system. For example, a process design team will obviously place a larger importance on lot traceability if the production system was making pharmaceutical products rather than paper clips.

Overall, exact categorization of a specific process is not crucial, however the team should utilize a set of metrics that would result in an objective analysis of each of the process elements and provide an adequate amount of differentiation between process elements.

As with the Physical Flow Relationship Chart, the complexity of an Informational Flow Relationship Chart increases quite quickly and dramatically with the size of the process under consideration. Because of this, the team only needs to identify the critical relationships, and then populate the remainder of the Chart as needed. If the task of creating the Informational Flow Relationship Chart is too daunting, the team can break the process under review into logical areas that are more



manageable. Once the overall relationships between these large areas are determined, the team can then look deeper into each area to identify those underlying relationships.

Once the Informational Flow Relationship Chart has been populated, the process team will discover that they are close to developing the optimal design configuration for the manufacturing information system. Once this stage has been reached, the team typically creates an Informational Flow Block Layout Diagram, the sixth (and last) major part of manufacturing process design.

### An Informational Flow Block Layout Diagram: The Sixth Foundational Element

The sixth and final major element in the development of a manufacturing process design is the Informational Flow Block Layout Diagram. This element commences the planning for the actual layout of the informational elements of the manufacturing system. This Diagram allows the design team to graphically visualize system designs, review information flows, and identify any external requirements or constraints for the process.

While the Physical Flow Block Layout Diagram is used to define the relative shape and size of each process element, as well as the location and orientation of those elements, the Informational Flow Block Layout Diagram allows the team to define specific elements of the information system. The Diagram shows the purpose that each process elements serves, the types of technology each of those elements will utilize, and how those elements interact with outside activities.

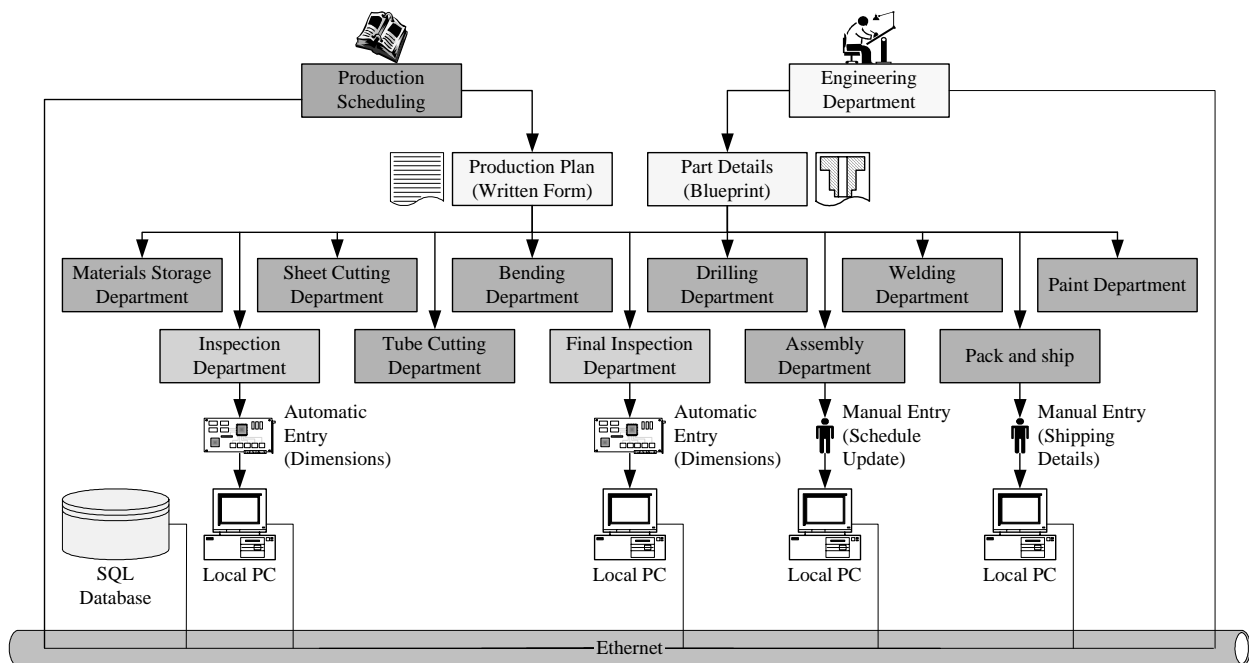

**Figure 26: A Sample Informational Flow Block Layout Diagram**

Informational Flow Block Layout Diagrams can be as detailed as the design team requires. Advanced Diagrams can show each and every type of information that is passed between process

elements, the frequency of that information, the structure and format of the information, and the exact algorithms used to process that information. Less advanced Diagrams show basic functional boxes, data flows, and uses. While the level of detail required should be set by the individual design team, the Diagram should be kept as simple as possible, to facilitate understanding and modification.

To construct the Diagram, the team reviews the Informational Flow Chart and the Informational Relationship Chart that show the information needs of each process element. Designers then select the level of information technology that will exist at each process element. The design team should consider modern computer systems, but should also remain open to using traditional paper-based processing, which in many cases is quite sufficient. In all process elements, the team should use a uniform platform so the overall complexity of the system is reduced, and the “Islands of Automation” can be avoided.

The team must also consider the informational constraints of communication system, such as storage capacity or the maximum number of simultaneous users. These requirements should be captured in as much detail as possible, as a minor change in them may have a major impact on the ultimate system layout. Therefore, at this stage, it is usually beneficial to invite multiple external parties to join the process design team, such as end users, IT network engineers, and information managers.

The team should then determine the most appropriate overall architecture for the required information system. Several possible designs are shown in Figure 6. Each design has advantages and disadvantages, and each is suited for a specific application.

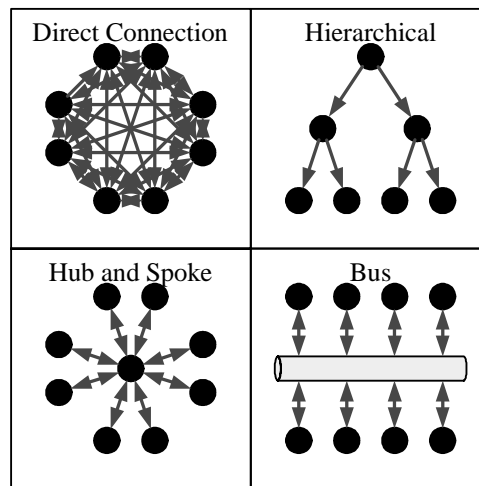

**Figure 27: Traditional Architectures Used In Information System Designs**

The **Direct Connection Pattern**, where process elements are connected directly to each other, is the design commonly used in systems that have gradually evolved over time. Any information that must be communicated between the two elements is sent via a dedicated link. This is advantageous since communication between selected components is rapid because the communication link has been

customized to send specific data between the two elements. However, this design is not effective in large systems, due to the number of links required to directly connect each and every process element.

The **Hierarchical Flow Pattern** is often present in very straightforward manufacturing processes. Under normal operation, information flows in only one direction. The source of information does not need to be aware of information that is generated at lower levels of the system. This design is beneficial since information flows are simple and the number of flows is kept to a low level. However, since the source of information has no structured way of becoming aware of information generated at lower levels of the system, vitally important information might never propagate back up through the system.

The **Hub And Spoke Flow Pattern** is often used in areas where all process elements communicate with one central process element, and all information transfer occurs through this one process element. This design is highly efficient, because information only needs to be maintained in one location. However, the one central process element may become overwhelmed with the amount of information flowing through it, and if this central point fails, the entire system will cease to function.

The **Bus Flow Pattern** uses an information pipeline concept, where all information is communicated to other process elements by the sending of information to one process element, whose entire purpose is to share information. Then, if process elements need to access information, they access the information bus. This design has all of the benefits of the hub and spoke pattern, as well as relieves the central process element from the tasks of information sharing. However, information must be actively requested by the process element, since the bus cannot send information directly to the process elements. Thus, this design does not guarantee that information will be disseminated to all areas.

In addition to these patterns, many other flow patterns exist. However, most of these patterns can be broken down into these fundamental communication structures.

Once flow patterns have been evaluated, the design team then can start to link the different sources and users of information. As with the Physical Flow Block Layout, this exercise should be performed a basic drawing program, so the designs can be easily modified, easily understood by multiple stakeholders, and allow multiple configurations to be compared simultaneously.

The development of the Informational Flow Block Layout may appear to be a daunting task, depending on the size and the complexity of the process being designed. However, the design team should start with the previously developed Informational Flow Relationship Chart and begin by placing the process elements that have an “Absolutely necessary” need for direct communication links. The design team then continues until all elements that have an “A” Proximity Rating are linked. The team then steps through the Relationship Chart to place the process items with “E” ratings, then with “I”

ratings, and so on. This should result in the linking of all information sources and sinks that exist in each process element.

The final result of this process is the Informational Flow Block Layout. This Layout is a rough representation of the information system architecture. Once the Block Layout has been developed, the design team will discover that they are ready to specify the design of the information system. Before the system design is committed to, the team should perform a final check to ensure that all stakeholders have been included, and all aspects related to the process design have adequately been reviewed. The team should review the Informational Flow Chart and the Informational Flow Relationship Chart to ensure that the information system architecture that has been developed realistically meets the flow intent and does not violate any underlying relationships between process elements.

At the completion of this step, will have a carefully developed system architecture that has been agreed to by all required stakeholders. In addition, the layout, and the process used to arrive at that design, will have been carefully documented for future reference. The team should feel satisfied with their progress and supportive of the new process.

## **15: Addressing the Second Major Shortcoming: The Overly Sequential Methodology**

As mentioned, the second major shortcoming is the overly sequential nature that the traditional design methodology uses to progress through activities and the methodology's failure to include all interested parties in the early stages of the design process. This sequential nature results has numerous drawbacks including extra time, effort, and resources needed to complete the design process.

Reviewing the disadvantages of sequential engineering and reviewing how the use of concurrent engineering techniques has transformed the product design process, will show the importance of considering the needs and requirements of all stakeholders early and throughout the design process. These findings will show how the traditional design methodology can be revised to leverage the many benefits of concurrent engineering.

### **The Disadvantages of Sequential Engineering**

For years, the launch of a new product was referred to as an "over-the-wall" process. Independent functional groups would perform a specific element of the product development process, and then pass the product along to the next functional group. "Prior to the 1980s, in most Western manufacturing companies, the work of marketing, designing developing, and delivering products proceeded according to a fixed sequence of events, all directed by a bureaucracy of managers, research

directors, and technicians.”<sup>115</sup> Little communication would occur, because each area believed they possessed all the information they needed to complete their part of the design process. “A typical company, much like a medieval castle, constructed protective walls around certain groups, functions, or departments, in effect keeping out people who did not belong.”<sup>116</sup> Figure 28 represents the traditional “walls”, while Figure 29 shows a representation of a typical sequential design process. While the sequential engineering approach allows each group to become highly efficient in their own tasks, the lack of communication across the groups leads to serious problems.

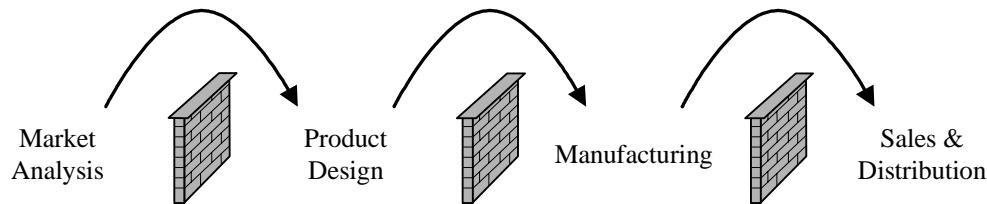

**Figure 28: Sequential Product Development<sup>117</sup>**

First, sequential engineering generally makes the product launch take longer than intended. This is because upstream functional groups fail to review their designs with downstream groups to discover issues that may require a major modification in the design. The lack of communication often meant that a design had to be sent back to earlier functional groups, thereby increasing the overall time needed to launch the product.

Next, not only did the lack of communication between groups result in increased overall development time, but any communication that did occur was often strained and confrontational.

“When discussions did occur between any of these groups, they were haphazard at best; and at worst, relations were deeply acrimonious. The inventors did not like to hear that they had designed products that could hardly be manufactured without costing a fortune. Meanwhile, those who actually built the item would point fingers at the purchasers for not securing the right materials on time. Product manufacturing often fell hopelessly behind schedule.”<sup>118</sup>

In addition to increased time and antagonistic behavior between different groups, sequential engineering leads to increased project costs. Typically, the need to make modifications is not identified

<sup>115</sup> Clockspeed: Winning Industry Control in the Age of Temporary Advantage, Charles H. Fine, Perseus Books Group, New York, New York, USA, 1998, Page 129.

<sup>116</sup> *Ibid*, Page 129.

<sup>117</sup> “A Knowledge-based approach to modeling manufacturing costs at the design phase of a product’s life-cycle”, S. Rehman & Prof. A. J. Morris, IT and Manufacturing Partnerships: Delivering the Promise – Proceedings of the Conference on Integration in Manufacturing, Galway, Ireland, October 204, 1996, J. Browne, R. Haendler Mas, and O. Hlodversson (Editors), IOS Press, Amsterdam, The Netherlands, 1997, Page 216.

<sup>118</sup> Clockspeed: Winning Industry Control in the Age of Temporary Advantage, Charles H. Fine, Perseus Books Group, New York, New York, USA, 1998, Page 130.

until quite late in the process. When these late changes are required, it becomes very expensive, since significant investment has already been made in the existing design and the production process.<sup>119</sup>

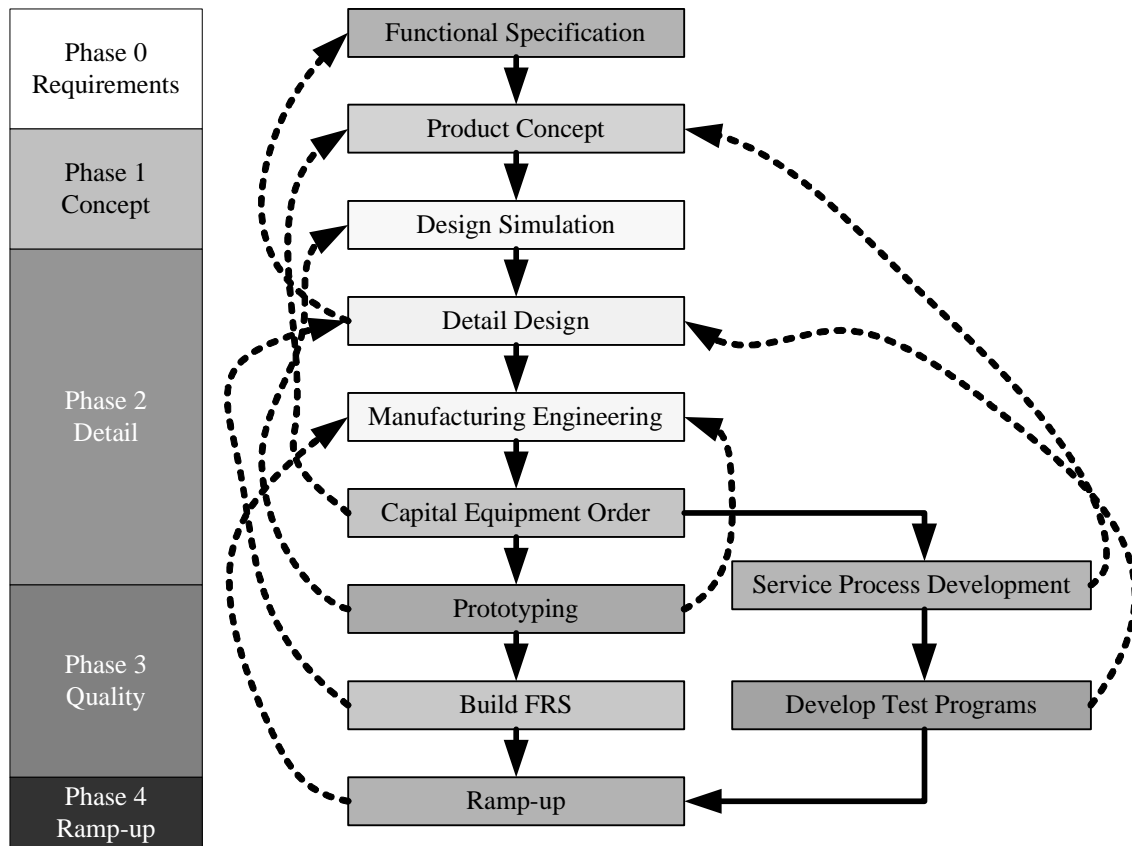

**Figure 29: Sequential Engineering Leads To Rework, Higher Cost, and Longer Time<sup>120</sup>**

Next, sequential engineering often leads to product designs that are overly complex and ignore the underlying requirements of the end customer. Each group is forced to make compromises in the product design to account for decisions made by earlier functional groups.

“By the time the [downstream functional areas] suggest that changes be made to the design, it is usually too late for them to incorporate any new ideas they may have. Either the design has been frozen already or there is insufficient time or funds to build a test cell to prove the new methods.”<sup>121</sup>

In addition, upstream groups seldom consider the impact of their decisions or the overall complexity of the product concept. “Normally the concept will be taken through to the design stage without any

<sup>119</sup> Concurrent Engineering: Shortening Lead Times, Raising Quality, and Lowering Costs, John R. Hartley, Productivity Press, Cambridge, Massachusetts, USA, 1992, Page 18.

<sup>120</sup> Ibid, Page 11.

<sup>121</sup> Ibid, Pages 204-208.

detailed assessment of how easily it can be produced – and unless a manufacturing feasibility study is detailed, it is unlikely to reveal the problems.”<sup>122</sup>

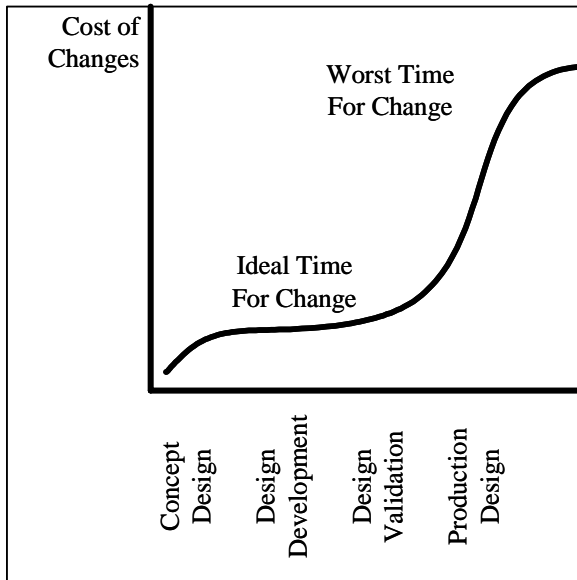

**Figure 30: The Usual Cost Pattern Incurred By Late Changes<sup>123</sup>**

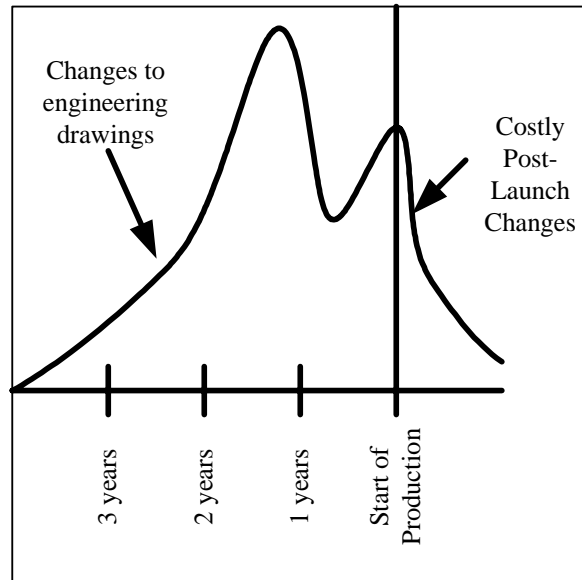

**Figure 31: Delayed Costs Incurred After Over-The-Fence Engineering<sup>124</sup>**

In conclusion, sequential engineering is far from the ideal design model. The use of sequential engineering leads to “delays and costs that ultimately translate into lost market share in today’s environment”<sup>125</sup> To overcome these negative effects, many firms have dramatically altered their product design process. “As the Clockspeed of industry after industry has begun to heat up from the driver of global competition, the necessity of concurrency has struck home.”<sup>126</sup> They have embraced concurrent engineering and, as a result, have reaped significant cost, timing, and simplicity benefits.

### **The Advantages of Concurrent Engineering**

Concurrent Engineering (CE), first developed by Nevins and Whitney, offers a vastly improved approach to product design. By using CE, “manufacturers have demonstrated that significant savings of time, as well as significant improvements in quality and in overall product cost, can be achieved by

<sup>122</sup> Ibid, Page 126.

<sup>123</sup> Ibid, Page 18.

<sup>124</sup> Ibid, Page 95.

<sup>125</sup> Concurrent Design of Products and Processes, James L. Nevins & Daniel Whitney, McGraw-Hill, New York, 1989, Page 17.

<sup>126</sup> Clockspeed: Winning Industry Control in the Age of Temporary Advantage, Charles H. Fine, Perseus Books Group, New York, New York, USA, 1998, Page 132.

lowering [walls] and eliminating the barriers between design and manufacturing.”<sup>127</sup> In addition, Concurrent Engineering techniques allow a much better understanding of customer wants, which ultimately yields a more successful product.<sup>128</sup>

Rather than passing the current version of the design concept from one functional group to another, with CE each functional group is brought together at the initial stages of product design. “Concurrent Engineering designates all techniques, tools, and work practices that all different skills to develop a product in a concurrent and interactive manner so that development cycle is reduced and reworks minimized as people work together, right from the beginning.”<sup>129</sup> “CE seeks to improve manufacturing performance not only by making changes, substantive or incremental, at the factory, but by coordinating the design of products with the actual production system in the factory.”<sup>130</sup> This methodology yields dramatic results, since it “is designed to encourage a new way of thinking about a product and how it is produced.”<sup>131</sup>

Using Concurrent Engineering, each group expresses their requirements and capabilities, and then develops a concept that addresses each of those aspects. Working simultaneously on a common design concept, as shown in Figure 32, the team’s efforts result in an earlier identification of possible design conflicts, reduced overall project timing and cost, and the avoidance of design compromises that must be made to accommodate shortcomings in the original concept.

Concurrently Engineering design teams not only use inputs from multiple stakeholders to develop better product design, but the teams also use the input to improve the process that will manufacture those designs. Doing so allows the team to optimize of the design of the entire production system.

Many of the shortcomings of the sequential engineering process are the result of upstream processes not knowing the capabilities or constraints of downstream processes.<sup>132</sup> Therefore, it can be expected that many improvements can result by improving the sharing of information between all groups.

---

<sup>127</sup> Integrated Process Design and Development, Dan L. Shunk, Business One Irwin, Homewood, Illinois, USA 1992, Page 3.

<sup>128</sup> Ibid, Pages 47-48.

<sup>129</sup> “Concurrent Engineering Within Aerospace: A Practical Approach”, Jean-Michel Azon, 1996, IT and Manufacturing Partnerships: Delivering the Promise, J. Browne, Editor, IOS Press, Amsterdam, Netherlands, 1996, Page 38.

<sup>130</sup> Clockspeed: Winning Industry Control in the Age of Temporary Advantage, Charles H. Fine, Perseus Books Group, New York, New York, USA, 1998, Page 131.

<sup>131</sup> Concurrent Engineering: Shortening Lead Times, Raising Quality, and Lowering Costs. John R. Hartley, Productivity Press, Cambridge, MA 1992, Page 221

<sup>132</sup> Integrated Process Design and Development, Dan L. Shunk, Business One Irwin, Homewood, Illinois, USA 1992, Page 185.



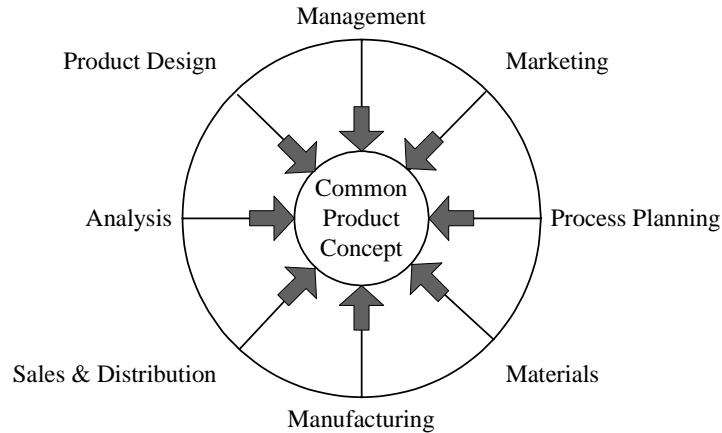

**Figure 32: Concurrent Product Development<sup>133</sup>**

“[All functional groups] should be in the team from the original concept stage, gaining data on customers’ requirements with other team members and discussing the direction in which the concept should go. After a very short time, [all team members develop] an in-depth knowledge of the volumes, the number of variations, and the general concept of the design.”<sup>134</sup>

“From the outset, when the design is no more than an artist’s sketch, manufacturing engineers in the task force have as much information on the product as anyone else in the team. They can begin planning the manufacturing facilities in the same conceptual way that the product designers are planning the object to be produced – they are working simultaneously. They can interrelate with the other members of the team, making recommendations to reduce cost and the parts count and to raise quality.”<sup>135</sup>

In addition, the early involvement of all functional groups ensures that those groups that will be most impacted by the product’s design will have sufficient warning to make necessary changes due to any innovative concepts included in the product design.

“Because the idea is accepted as a possibility from the outset, design and manufacturing both have time to undertake the rigorous testing needed for such a new concept, with the potential of turning a troublesome design into a simple and inexpensive one.”<sup>136</sup>

---

<sup>133</sup> “A Knowledge-based approach to modeling manufacturing costs at the design phase of a product’s life-cycle”, S. Rehman & Prof. A. J. Morris, IT and Manufacturing Partnerships: Delivering the Promise – Proceedings of the Conference on Integration in Manufacturing, Galway, Ireland, October 204, 1996, J. Browne, R. Haendler Mas, and O. Hlodversson (Editors), IOS Press, Amsterdam, The Netherlands, 1997, Page 216.

<sup>134</sup> Concurrent Engineering: Shortening Lead Times, Raising Quality, and Lowering Costs, John R. Hartley, Productivity Press, Cambridge, Massachusetts, USA, 1992, Page 212.

<sup>135</sup> Ibid, Page 16.

<sup>136</sup> Ibid, Page 209.

Also, CE greatly reduces the time required to complete the overall design process, due to the elimination of major design modifications.

“Only a small amount of work carried out in the process of planning, ordering, and setting up a man plant was adding value.... two-thirds of the time spent by people involved in the project does not add value. Some is spent waiting for information and some of it is spent on work made redundant by decisions taken later on. To increase the proportion of added value in these operations, [all functional groups] must be involved in the task force.”<sup>137</sup>

Finally, the use of Concurrent Engineering produces designs that have higher quality and are serve as better solutions to customers’ demands. “An important principle of Concurrent Engineering is that quality is built into the design from the start, with any features that will be adversely affected by variations in production being designed out.”<sup>138</sup> By documenting requirements from all functional groups at the start of the process, the strength of customer requirements is not diluted as the concept moves through the design process.

Therefore, Concurrent Engineering practices can eliminate many of the negative consequences of Sequential Engineering. The process reduces the overall time and cost of design projects, eliminates the need for late redesigns, and generates design concepts that have highly quality and lower complexity. In addition, the simultaneous consideration of the product design, the process design, and the design of any required support activities ensures that the overall manufacturing system will be a cohesive and mutually reinforcing, synergistic system.

### **Adapting Concurrent Engineering to Include Designing the Information System**

It was shown earlier that not considering the design of information systems when planning the physical production system resulted in substantial problems for the production process. By waiting to design the information system until after the physical process had been put into place, the design team compromised the ultimate performance of the production system. The cost to implement the information system was increased, as well as the time required to implement such a system. In addition, the resulting information system often was overly complex, and did not meet all the demands of the end customers.

These consequences are dramatically similar to the negative effects that occur when a design team utilizes a sequential rather than a concurrent engineering design process. The added costs, timing and complexity, as well as the inadequate addressing of customers needs are all direct results of sequential engineering.

---

<sup>137</sup> Ibid, Pages 211-212.

<sup>138</sup> Ibid, Page 19.

In fact, any type of sequential processes can benefit greatly from the use of concurrent engineering. This has been recognized and presented by Fine, in his Three-Dimensional Concurrent Engineering (3DCE Concurrent Engineering) framework.<sup>139</sup> This framework shows that tremendous benefits can result from the use CE not only for product design, but also for process design and supply chain design.

This suggests that the use of concurrent design methods in the planning of an information system would yield a similar level of dramatic improvement that concurrent engineering has brought to the design of a product. In addition to considering the design of a process and the design of a product at the same time, the design team can now also consider the information system that ties all elements of the system together.

By bringing in key developers, users, and generators of information into the early stages of the process design project, the needs of all major stakeholders can be identified. Physical process elements can be designed around the needs and capabilities of the information system. In addition, informational process elements can be designed around the needs and capabilities of the physical production system. The result is a seamless blend of system requirements that is identified early in the design process. Once all the needs are identified, the process design that is developed will have a better chance of optimally meeting the global needs of all parties.

To actually achieve concurrent design of the information system and the physical production system, the design team must modify their underlying design methodology. New techniques must be employed to ensure that the design of the informational flow system receives as much (if not more) attention than the physical flow system. Fine presents that the major steps in Concurrent Engineering involve:<sup>140</sup>

1. Analyze first the architectural design of both processes and production in order to identify fundamental problems. Then scrutinize the details of the actual design of products and the processes in place to produce them.
2. Break down the product and process systems into their component parts, or subsystems, and identify the interactions within and across them.
3. Align the requirements for the actual design of the product with those for the process design and organizational structure.
4. Explore alternatives for the primary product design process and manufacturing process.
5. Estimate early the costs of adopting various process options.
6. Estimate early the time requirements – in person-hours, but especially in the critical path time effects – of executing different design options.
7. Identify and alleviate any bottlenecks in the CE process.

---

<sup>139</sup> Clockspeed: Winning Industry Control in the Age of Temporary Advantage, Charles H. Fine, Perseus Books Group, New York, New York, USA, 1998, Page 132.

<sup>140</sup> Ibid, Page 132.

8. Manage the design process with multi-functional teams, working concurrently.
9. Align incentives for design such that trade-offs associated with selecting design options will be made from a global product life cycle perspective.

To ensure that the design of the informational flow system was considered during the manufacturing system design process, specific tools were introduced, such as the Informational Flow Relationship Chart.

To move from sequential engineering to concurrent engineering, no specific tools need to be used. However, the team does need to alter the order and flow of steps in the design process to ensure that outside parties are included sooner in the design process, and these stakeholders remain part of the design team throughout the entire project.

## **Part V**

---

### **An Improved Process Design Methodology**



## 16: Description

The key improvements identified can be now combined with the traditional design methodology to produce an improved manufacturing process design methodology. This design technique, represented in Figure 33, takes advantage of the wealth of knowledge and experience with the traditional design methodology as well as overcomes the two major shortcomings of that design process.

The core elements of the improved methodology remain as described in the traditional process. The first five steps (Formulating the problem, Broadening the Scope of the problem, Gathering key inputs, Brainstorming concepts, and Screening concepts) allow the design team to fully examine the underlying problem, expand their thinking to consider new approaches, and then choose new design ideas capable of addressing the key issues in novel and simple ways. The downstream stages further develop these concepts by utilizing graphical tools that identify the flows, relationships, and relative placement of major process elements. The team then evaluates the set of concepts using a specified set of criteria and selects the concept that best meets the design goals, while still meeting all practical limitations and external requirements. At many stages of the process, the design team pushes to incorporate Lean Production Fundamentals. In addition, designers continuously reformulate the underlying problem and push to simplify each process element so that overall system complexity can be minimized. Finally, computer simulation tools are used at two distinct stages first to calculate process requirements and then later to predict the performance of the process.

By keeping much of the traditional design methodology intact, the numerous benefits of its techniques can be retained. In addition, design teams that are familiar with the traditional design process will not have to radically modify their procedures in order to use the improved design methodology.

While the traditional and the improved methodologies share many of the same stages, the techniques differ in two major areas. First, the improved design methodology differs in that it requires the team to solicit input from other areas during the very early stages. The traditional methodology waits until the concept is fully developed and then modifies the design to accommodate outside requirements and practical limitations. By waiting until these late stages, the design team takes more time and resources to complete the project, and the final design is a complicated mixture of the original concept and several suboptimal compromises that satisfy constraints discovered late in the process. The improved methodology, on the other hand, receives this input at the very early stages of the process. Design concepts are developed with the external factors in mind, so that no major downstream modifications will have to be made to account for new considerations. Valuable time and money are saved, and the overall concept will meet all project requirements with a simple and straightforward approach.

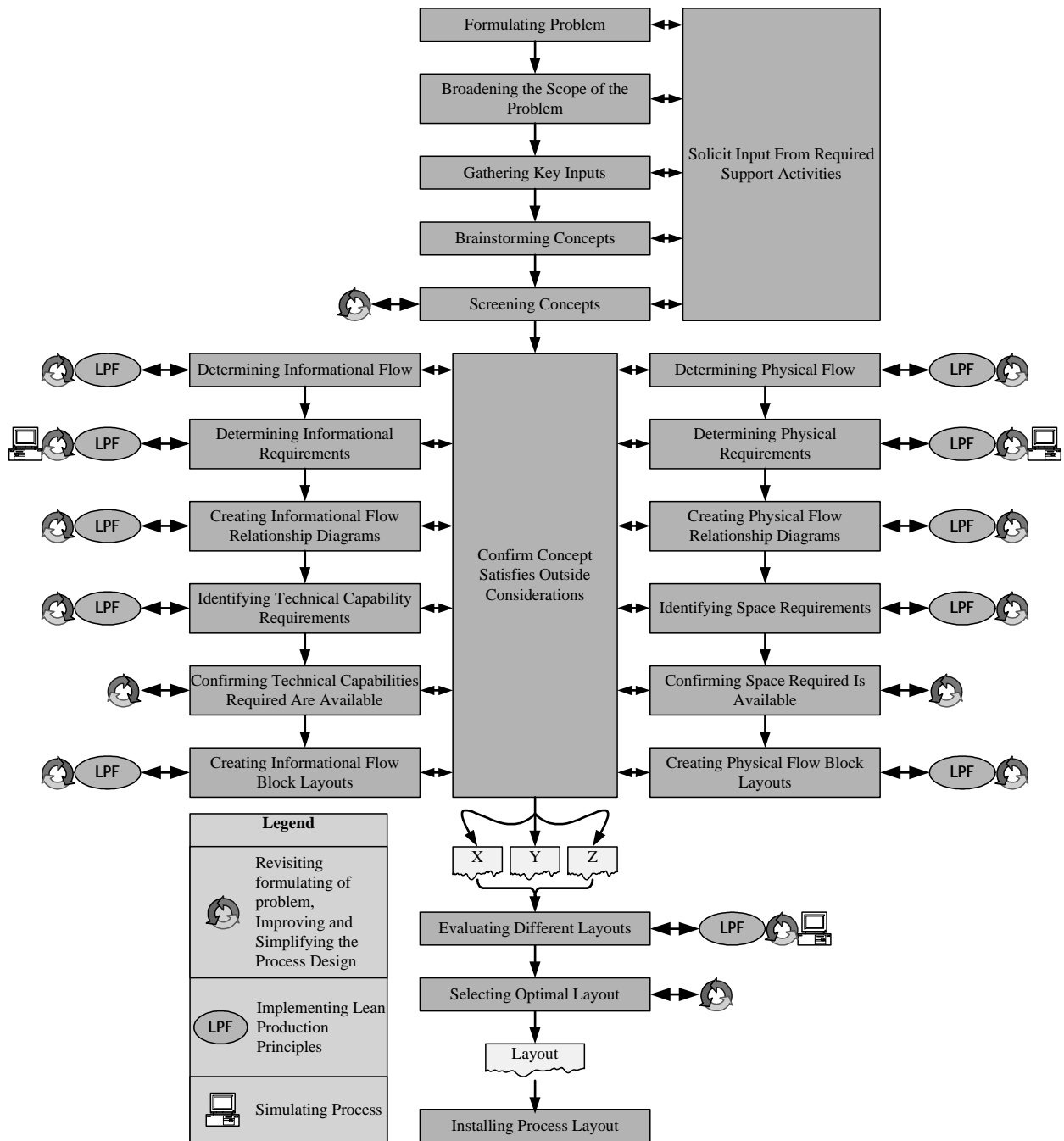

**Figure 33: Improved Design Methodology**

The second major difference is the improved design methodology now formally includes stages that consider the design of the informational flow system. This ensures that the information system, which is becoming an increasingly important component of manufacturing systems, receives the design attention it requires.



To adequately consider the informational flow system's design, six new stages have been added to the design process. The first stage, labeled as Designing Informational Flow, requires the design team to identify the major process elements of the information system as well as the type and the sequence of those process elements. Using this information, the team develops the Informational Flow Chart, the fourth Foundational Element of the improved design methodology. (The Physical Flow Chart, Physical Flow Relationship Chart, and the Physical Flow Block Layout Diagram are the first three foundational elements.)

Designers then complete the next step, Determining Informational Requirements. In this step, the team calculates the level of communication and volume of data that will occur between each pair of process elements. Based on these calculations, the team develops a feeling for the type of technology that may be required to support each links.

The design team then constructs the Informational Flow Relationship Diagram, the fifth Foundational Element of the improved design methodology. This Diagram allows the team to discover and document complex informational relationships between process elements that may not be apparent from the Informational Flow Chart. This Diagram highlights process elements that must be linked due to the volume and complexity of information that is passed between them. The Diagram also highlights process elements that must not be linked due to security or other reasons.

Next, the design team completes the stage where technical requirements are identified. During this stage, the team calculates what level of technology will be needed to meet the needs of the informational flow system. The technology may include all levels ranging from verbal communication to custom developed computer applications. Also at this stage, the team discovers what systems are used by the greater firm, and searches to see if an existing system is capable of being used in the concept being developed.

The next stage involves the confirming that the systems required by the design concept are indeed available and can be implemented.

The final new stage involves the construction of Informational Flow Block Layout Diagram, the sixth and last Foundational Element of the improved design methodology. This Diagram shows all major sources and uses of information in the system, what technical systems and methods are used to transfer, analyze, and store that information, and how the system will interact with outside systems.

Each of these stages has a complimentary stage that considers the design of the physical flow system. It is vital that the design complete these stages together, so that the informational flow system and the physical flow system are built using the same process elements, placed in the same sequence, and using the same level of technology. This also ensures that the informational system and the physical

system are compatible, the overall level of complexity is as low as possible, and both systems are being built to address the same fundamental problem.

The remainder of the design methodology proceeds as defined in the traditional methodology. The different concepts are evaluated to ensure they meet the performance requirements and address the underlying problem. After all the concepts are then compared to each other, the design that meets all constraints and produces the best performance is chosen and implemented.

## **17: Benefits of the Improved Process Design Methodology**

The improved manufacturing process design methodology offers numerous benefits to the design team. First, it continues to provide the many benefits of the traditional design methodology, which include: flexibility and adaptability of the process to a wide variety of settings, a formalized process that gives structure to the design process, and a system of design review tools that generate a comprehensive set of documentation detailing the design process. Next, the improved methodology properly accounts for the increasing roles that information flow and information technology play in today's manufacturing systems. In addition, the improved methodology offers three new formal design tools that can assist process architects in the development of their concepts. Finally, the improved methodology recognizes the important need for concurrent design of the physical flow and the informational flow systems. Together, these multiple benefits ensure that the improved process design methodology presented in this thesis will be a valuable tool for manufacturing process design teams.

## **Part VI**

---

### **Case Illustrations Where The Improved Design Methodology Was Used**



A number of case illustrations can be used to illustrate how the improved design methodology can be applied. Chapter 18 revisits the production of an automotive ignition coil and demonstrates how an Informational Flow Chart could have been effectively used to examine a manufacturing system. Chapter 19 revisits the placement of electronic components on a Formula One racecar and demonstrates effective use of an Informational Flow Relationship Chart. Chapter 20 examines the manufacturing system for the production of an automotive starter motor and demonstrates how an Informational Flow Block Layout Diagram could have been used and might have prevented some of the performance shortfalls of that system. Finally, Chapter 21 shows how all six of the key foundational elements can be used while applying the improved manufacturing process design methodology to design a manufacturing system for a digital camera.

## **18: An Informational Flow Chart For The Production of An Automotive Ignition Coil**

Chapter 9 showed how the traditional design methodology was applied to the design of a manufacturing system for an Automotive Ignition Coil. Specifically, it was demonstrated that the Physical Flow Chart is a valuable tool for identifying distinct process elements, the type of those elements, and the sequence in which those elements must be placed for proper manufacturing of an ignition coil. The development of the Physical Flow Chart allowed the design team to identify several areas where the existing process design could be altered, which would simplify the overall system and improve the resulting performance of the process.

In a similar manner, the use of an Informational Flow Chart can be valuable to a process design team, whether their project involves the redesign of an existing information system or developing a system for a completely new process.

The design team involved in the improvement of the coil production process did not develop and Informational Flow Chart during their project. However, if they had, several insights into the current process could have been made which may have resulting in even greater improvement of the redesigned process' performance.

To construct an Informational Flow Chart, the design team would have first started by listing all of the information flows through the system. The first information flow consists of the weekly production schedule that is communicated between all process elements. Each process element reviews this information flow, performs operations according to the schedule, and then updates the production plan based on actual results. The flow of the production plan is actually a closed-loop flow, since the overall production yield of the process is shared with the production planning office, the originator of the actual system. The second flow concerns the flow of assembly specifications from the product engineering

office to each of the process operations. Another flow includes functional test results, which is fed back to upstream operations so that process modifications can be made. This information is also flowed downstream and supplied externally to activities such as the product engineering and quality control offices. Other information flows exist, such as the sharing of machine status with external maintenance areas and the sharing of emissions levels with the environmental control office.

Then, the design team would have categorized each process element based on its core information function. Some elements would be designated as information operations, others as information storage steps. Next, the team would have determined the necessary sequence of these elements in order to produce the ignition coils.

Once this was completed, the design team would have graphically represented the multiple information flows through the production system, and their representation would have resembled the flows shown in Figure 34 and Figure 35.

By examining the information flows of the original process, the design team would have identified several opportunities for improvement. These improvements would have reduced the overall complexity of the system, facilitated communication between process elements, and leveraged the power of information to allow product engineers to improve the design of the automotive coil.

The creation of the Informational Flow Chart would have identified the lack of an efficient link between the in-process electrical and the final functional tests. It would have been discovered that during operation, each coil's test results are recorded on local (non-networked) computers. To systematically analyze test results, engineers have to search the results files of both computers and translate the unformatted datasets into useable information. Complicating this matter is the fact that independent test algorithms are used for each station. As a result, the data being collected is in different structures, making comparison cumbersome and time-consuming. Therefore, rather than comparing final test results to in-process test results, as the process designers originally wanted, very little correlation is actually being performed.

To address this, the design team could have implemented a simple networked database that linked the two functional tests. A unique record would be created to store each part's in-process electrical test results. Later, the same part's final functional test results would be stored in the same database record. This would give process engineers a much-improved system for tracing a product's performance through the system, and allow them to identify source of process defects between the in-process and the final functional test operations.

Another process improvement could have been made if an Informational Flow Chart were developed. The team would have discovered that the production plan is currently passed from one station

to the next, and revisions are made to that production plan depending on actual production performance. For example, if one station produced lower yields due to a quality problem, it would be necessary to alter the downstream schedule to ensure that extra time is planned to make up the lost production. In the current system, process operators make these adjustments, and the central production planning office does not receive notification that the schedule has been altered until the current production run has been completed.

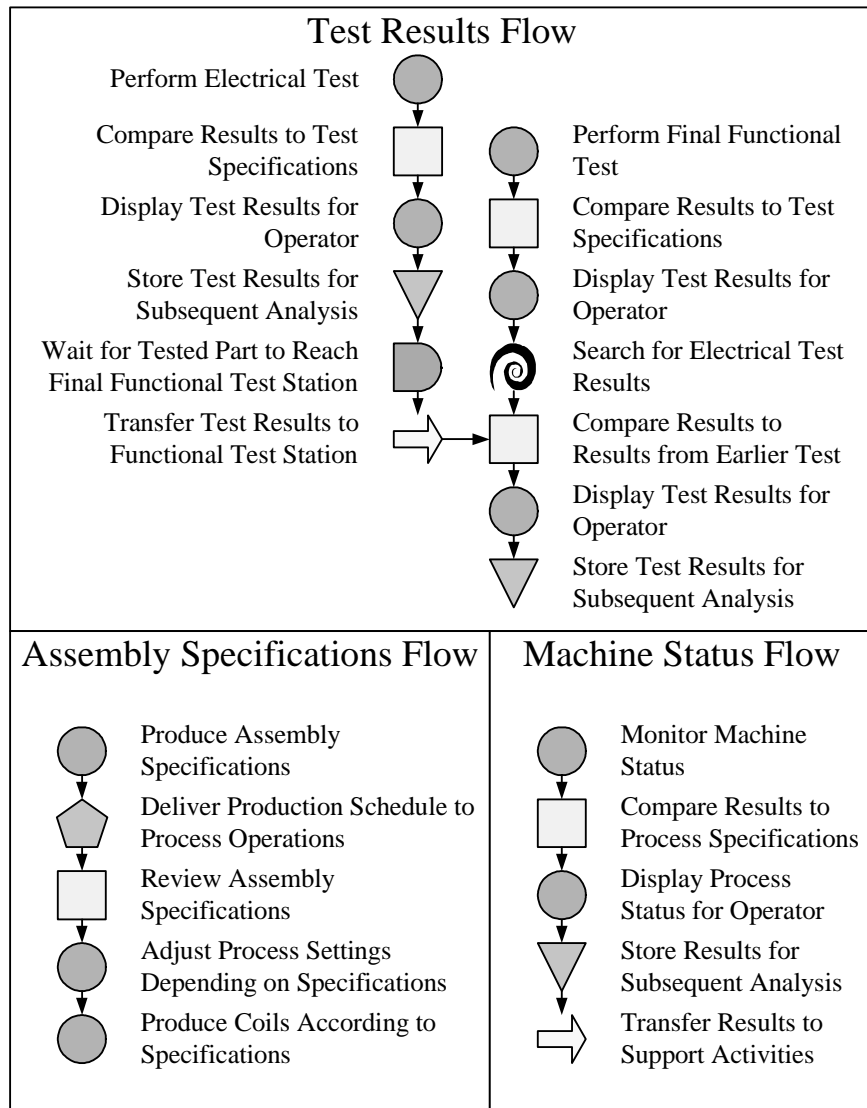

**Figure 34: Informational Flows For Coil Production Process**

To address this, the team could have determined that the central production planning office should determine and adjust the production plan as necessary. A centralized system where individual operators report the current status of a station's production performance could provide the department the

information they need to make the adjustments. These adjustments could be made on a more frequent basis, which would result in more uniform production scheduling and a more responsive process.

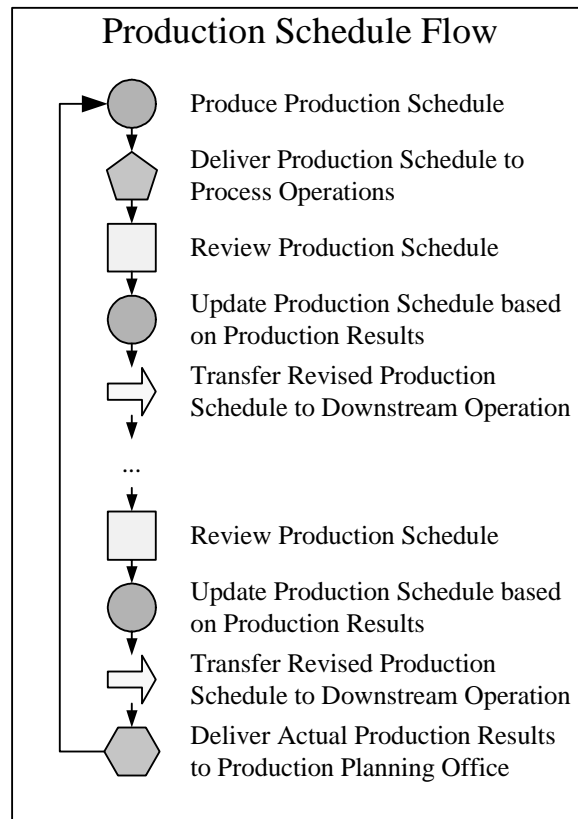

**Figure 35: Informational Flows For Coil Production Process**

Therefore, the creation of an Informational Flow Chart allows the design team to discover process elements and aspects of a production system that they may not have thought of when designing the physical flow system. It is vital that these aspects are found, since the flows of information through a manufacturing system are becoming more important as processes become more data intensive. By carefully defining and systematically categorizing these elements, and determining the proper sequence of those elements, the process design team can often identify significant opportunities for process improvement and simplification while becoming much more knowledgeable about each process element.

### **19: A Informational Flow Relationship Chart for a Formula One Racecar**

Chapter 10 examined the placement of the individual electronic components that control the dynamics of the racecar and treated their placement as an abstracted factory layout problem. The case demonstrated how the use of a Physical Flow Relationship Diagram can be used to identify and categorize the relationships between all process elements and can greatly assist the team in developing an optimal layout.



In a similar manner, the Informational Flow Relationship Diagram can be used to identify the major relationships between process elements as they interact on an informational sharing basis. Those process elements that must communicate directly are clearly identified, while those elements that must be prevented from communicating are also clearly expressed.

Figure 36 shows the Informational Flow Relationship Diagram for the Formula One Racecar that was previously examined. By reviewing several of the relationships identified, the power of this Diagram can be demonstrated.

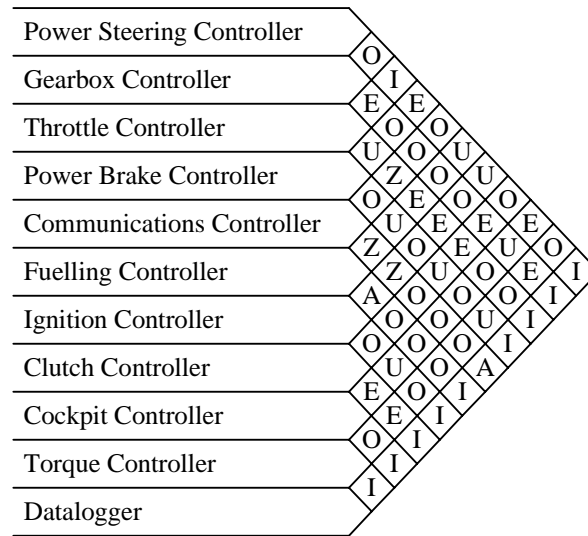

**Figure 36: Informational Flow Relationship Diagram**

First, for several components, their direct connection is absolutely necessary. Many of these elements are involved in the control of the vehicle’s engine. For example, the fuelling and ignition controller must be continuously connected, since together they control the fastest part of the entire racecar: the combustion of air and fuel inside the engine’s cylinders. A dedicated link between these elements is used in order to guarantee the correct amount of fuel is injected into the combustion chamber and the spark plug is energized at the optimal time even at engine speeds up to 21,000 revolutions per minute.

Next, the Relationship Diagram shows that communication between certain process elements is extremely important. For example, the clutch controller and the gearbox controller must communicate directly, since both controllers are intimately involved in the shifting of the vehicle’s gears. Since the shifting of gears must occur within an extremely short time span, the controllers cannot afford to transmit information using another element. Attempting to do so would increase the total time to shift gears, which decreases the overall speed of the racecar.

Next, several other components have an ordinary relationship, where the information flow between the elements can be achieved by using a central computer. For example, the power steering system and the power brake systems both manage systems that operate at low speeds compared to other high-speed systems. Therefore, they are tolerant of using the central computer to receive and send data across the system. Both systems must be linked, so that engineers can review the behavior of the overall system, but a high speed or high capacity link between the elements is not needed.

In addition, there are some elements whose communication is undesirable. These elements are the fuelling controller and the power steering controller. This may seem odd, but this is because one manufacturer produces the engine and its control systems while another produces the chassis and its control systems. The engine manufacturer is concerned that the chassis manufacturer will share sensitive engine performance data with other engine manufacturers that it works with on other teams. The chassis manufacturer is concerned that the engine manufacturer will share sensitive chassis performance data with other chassis manufacturers that it works with on other teams. Thus, there is extreme sensitivity about the level of information that is available to people outside those “who need to know.” Therefore, the amount of communication that occurs between largely unrelated systems is kept to a minimum.

Finally, there are some elements that must not communicate with other elements. This is due to series regulations that prohibit the active adjustment of engine control systems during the race. As a result, all engine control systems are prevented from communicating with the communications controller. Communication can only occur via a passive information storage computer, known as the datalogger.

These relationships illustrate the power of the Informational Flow Relationship Chart. The discovery of these relationships allow the team to identify communication requirements that may not have otherwise been identified until late in the design process, where design modifications would have been extremely expensive.

In addition, the discovery of these underlying relationships helps inform the team of likely impacts to the overall system if the placement of one component must be changed. For example, when a rule modification was made to prohibit direct communication between the gearbox controller and the communications controller, the capacity of the datalogger had to be increased to ensure this added information could be collected.

This case shows that by understanding and categorizing relationships between process elements, a properly sequenced information flow can begin to be developed, where those process elements that must be directly linked together are indeed linked, and those process elements that must not communicate are indeed separated. Furthermore, the Informational Flow Relationship Chart can be combined with the Physical Flow Chart to identify and categorize most of the complex relationships between process

elements within a manufacturing system. The result is improved understanding of the manufacturing system, which increases the likelihood that the process designed will be an optimal solution to the problem facing the design team.

## **20: A Informational Block Layout Diagram for a Starter Motor Solenoid Subassembly**

Chapter 12 examined the use of the traditional design methodology to develop a manufacturing process for the production of an automotive starter motor. The design that was eventually implemented had several advantages over the prior design, but also had several limitations, due to the design team's neglecting of the flow of information through the process.

Specifically these oversights led to: (1) lost chances to catch quality defects before they escaped the process, (2) unneeded time and effort spent monitoring and recording production data that was already automatically being collected, and (3) costly equipment modifications late in the launch process.

Had the team considered the flow of information when designing the production system, many of these oversights would have been eliminated. To develop an improved design for the information system, the team should have developed an Informational Flow Block Layout Diagram for each subassembly production process. The Block Layout Diagram, even if it were as basic the one shown in Figure 37, would have addressed the four major oversights related to the flow of information, highlighted the major needs of the informational flow system, and documented the informational technologies required to meet those requirements.

First, by creating a centralized file where test results were stored, the design team could have provided a means to link the output from the four different functional tests. This would have enabled process engineers to monitor and diagnose the behavior of the production system, thereby allowing them to discover systematic quality defects that could not be detected by the individual functional tests. Next, creating the Diagram would have allowed the team to discover that several of the process elements were advanced enough that the test results could be directly fed into the results file, thereby eliminating the need for a manual data recording process. Finally, the team would have recognized the need for a statistical monitoring tool, as well as the need for global access to the current results of the process.

Therefore, just by developing this Informational Flow Block Layout, the major elements of the process information system could have been identified, and technologies capable of meeting the information flow requirements could have selected and allocated to those process elements. The added costs, timing, and efforts needed to implement an information system could have been minimized. In addition, the overall complexity of the information system could have been reduced, since the fundamental system needs would have been identified during the original planning stages of a process.

In conclusion, the Informational Flow Block Layout is a valuable tool in the planning and design of an informational flow system and should be utilized by all manufacturing process design teams.

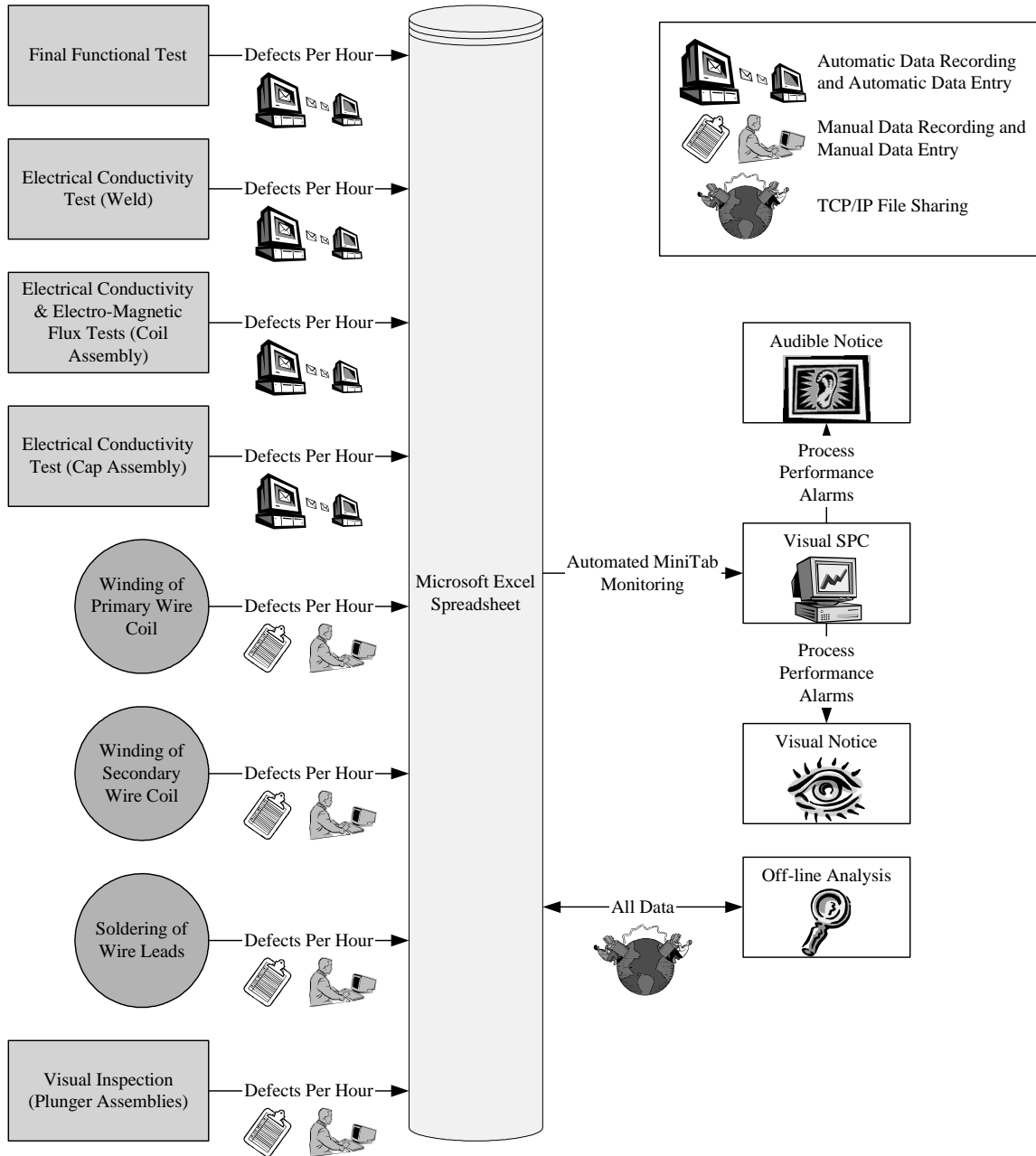

**Figure 37: The Informational Flow Block Layout For The Production of an Automotive Starter Motor Solenoid**

## 21: Designing a Manufacturing System for the DCS Pro 14n Digital Camera

This case illustration examines the development and implementation of a manufacturing system for Eastman Kodak Company's DCS Pro 14n high performance digital camera. This camera is a

revolutionary product, both for the digital camera industry as well as for Kodak. Because of its strategic importance, significant resources were dedicated to the design of a completely new production system to assemble this camera.

This case illustration demonstrates how the process design team used the improved design methodology described in this thesis to first examine the production system used to assemble the current model digital camera and then develop a vastly improved manufacturing system to produce the Pro 14n.

## Background

Since the early 1990s, the Eastman Kodak Company has produced a line of high performance digital cameras. These cameras were developed for the small, but strategically important professional photography market segment that includes photojournalists, sports, wedding, studio, catalogue, and portrait photographers.

For these customers, digital cameras greatly simplify the workflow of photography, as demonstrated in Appendix D. Photographers no longer have to pause to change rolls of film, need additional equipment to develop photographs, or use specialized facilities to archive film negatives. In addition, the photographers no longer have to spend significant sums to purchase film.

During the early development of digital photography, many professional photographers remained loyal to traditional photochemical photography. This was because the resolution<sup>141</sup> of digital images was not as high as film images. However, the current level of digital image quality now surpasses film and as a result, the vast majority of professional photographers, and a growing number of amateurs, has made the transition to digital cameras.<sup>142</sup>

Since the bulk of the company's revenue comes through the sale of photochemical film, it may seem peculiar that Eastman Kodak markets digital cameras. However, the company believes that it is vital to remain a major market player in the professional segment. Even though Kodak no longer profits from the sale of professional film, the lost revenue is more than offset by the sale of digital cameras, storage media, image-processing software, and printing paper. These products allow Eastman Kodak to maintain its leadership position in the photographic industry, even though the penetration of digital photography has greatly changed the competitive makeup of that industry.

## The Manufacturing of the DCS 760 Camera

---

<sup>141</sup> The resolution of an image affects the level of detail that can be represented, as well as the size that the image can be expanded before details in the image become noticeably fuzzy. Resolution is typically measured in Megapixels. As a benchmark, 4 Megapixels allow prints as large as 20"x30" without a noticeable loss of image sharpness.

<sup>142</sup> For additional details about the digital camera market, refer to Appendix C.

All of Eastman Kodak's professional digital cameras have been manufactured using an internal division, located in Rochester, New York. This division is closely aligned with Kodak's central research and development division, allowing the company to rapidly bring the latest digital imaging technology to market. Over the past eight years, Kodak has developed over 12 different digital camera models, constantly pushing the envelope on image quality and electronic performance.

The current model produced in this division is the DCS 760, pictured in Figure 38. The DCS 760 is built using a modified Nikon® F5<sup>143</sup> SLR camera body, whose traditional mechanisms to position the 35mm film canister and advance the film have been removed and replaced with electronics that capture, manipulate, and store the image digitally. The DCS 760 captures images at resolution levels up to 6 Megapixels and has a retail price of approximately \$8,000.



**Figure 38: DCS 760 Digital Camera<sup>144</sup>**

The price of this camera may seem quite high. However, these prices are very attractive to professional photographers due to the incredible workflow transformation that occurs by changing to a digital platform. Film savings alone can account for almost \$4000 per year, and the additional time and effort savings more than offset the remaining added cost of the camera.

The professional customers that purchase DCS 760 cameras have specific and stringent demands for product quality and performance. First, because these customers use the cameras to earn their livelihood, they demand the images recorded are defect-free. Pictures must have no pixel defects, where some pixels always appear white or light grey, where some pixels always appear black or dark grey, where the color of a specific area of the image does not match the surrounding areas, or where an extremely bright area of the image causes color and contrast distortion in neighboring areas. In addition,

---

<sup>143</sup> A Nikon F5 camera body was chosen since most professional photographers have already invested thousands of dollars in Nikon lenses, which use the Nikkor AF mounting mechanism unique to Nikon cameras. To avoid requiring customers to purchase new lenses, Kodak chose to build the DCS 760 using the Nikon camera body.

<sup>144</sup> Image provided courtesy of Eastman Kodak Company, ©Eastman Kodak Company, 2003

the camera's imager must remain free of particulate contamination, scratches, or other damage. Finally, the software used to store and manipulate the images must function perfectly and as quickly as possible.

Next, because many of Eastman Kodak's professional camera customers are corporate photography departments, each camera must produce uniform and repeatable results. These customers typically maintain a pool of cameras from which their photographers select a camera prior to an assignment. Because of this, the photographers do not always receive the same camera for every shoot. The photographers need to be confident that every camera they choose will produce results that are expected and that the camera behaves identically to every other camera in the pool.

Finally, at the time the DCS 760 camera was launched, digital image quality had just recently surpassed the quality of traditional film. However, many customers still did not understand many of the advanced features unique to digital cameras. Radical new concepts for camera shapes, sizes, and controls were developed, however, Kodak's customers demanded that the DCS 760 was built using a familiar camera platform. By making the controls and functionality of the camera identical to the controls for a traditional camera, it would become easier for photographers to make the transition to digital cameras.

These three vital areas (quality, consistency, and familiarity) have become dominant factors in the design of the manufacturing systems for the DCS 760. The manufacturing system has been developed to ensure perfect product quality and consistency, even if the overall complexity and cost of the system was increased. The end result are cameras with perfect, predictable, and guaranteed performance.

The manufacturing system for the DCS 760 can be represented symbolically in Figure 39. While the exact description of each process operation is not important, examining the overall structure shows how the manufacturing system's design was influenced by the customers' requirements.

First, it can be seen that the process flow is highly sequential. This flow was due to the high complexity of the assembly process. Since the DCS 760 was built using a modified traditional camera body, its design had not optimized for the final product. No modular subassemblies existed, and as a result, the process needed to perform one complex assembly operation after another. Because of this complexity, the assembly steps have been split into discrete units, and assigned to specific work areas on the production floor. An operator that has been highly trained to complete these specific tasks was then assigned to each of those areas. These operators have all the tools and equipment necessary to complete their tasks, and are largely self-sufficient. These operators tend to work as fast as possible, producing as many parts as they have available. While this practice results in the build up of inventories between each process steps, these inventories ensure that the final functional test stations (which are the process bottlenecks) are continually supplied with cameras.

Next, it can be seen that there are a large number of functional test operations, and many of these operations are placed near the end of the process. This is since the complex design of the camera does not allow in-process tests to be performed. In order to assure that all quality defects are caught before the product is shipped from the factory, multiple tests are performed, and some of these tests are actually redundant performance checks of features that were checked during earlier tests. However, this redundancy is tolerated in order to capture all defects before the cameras can reach the customer.

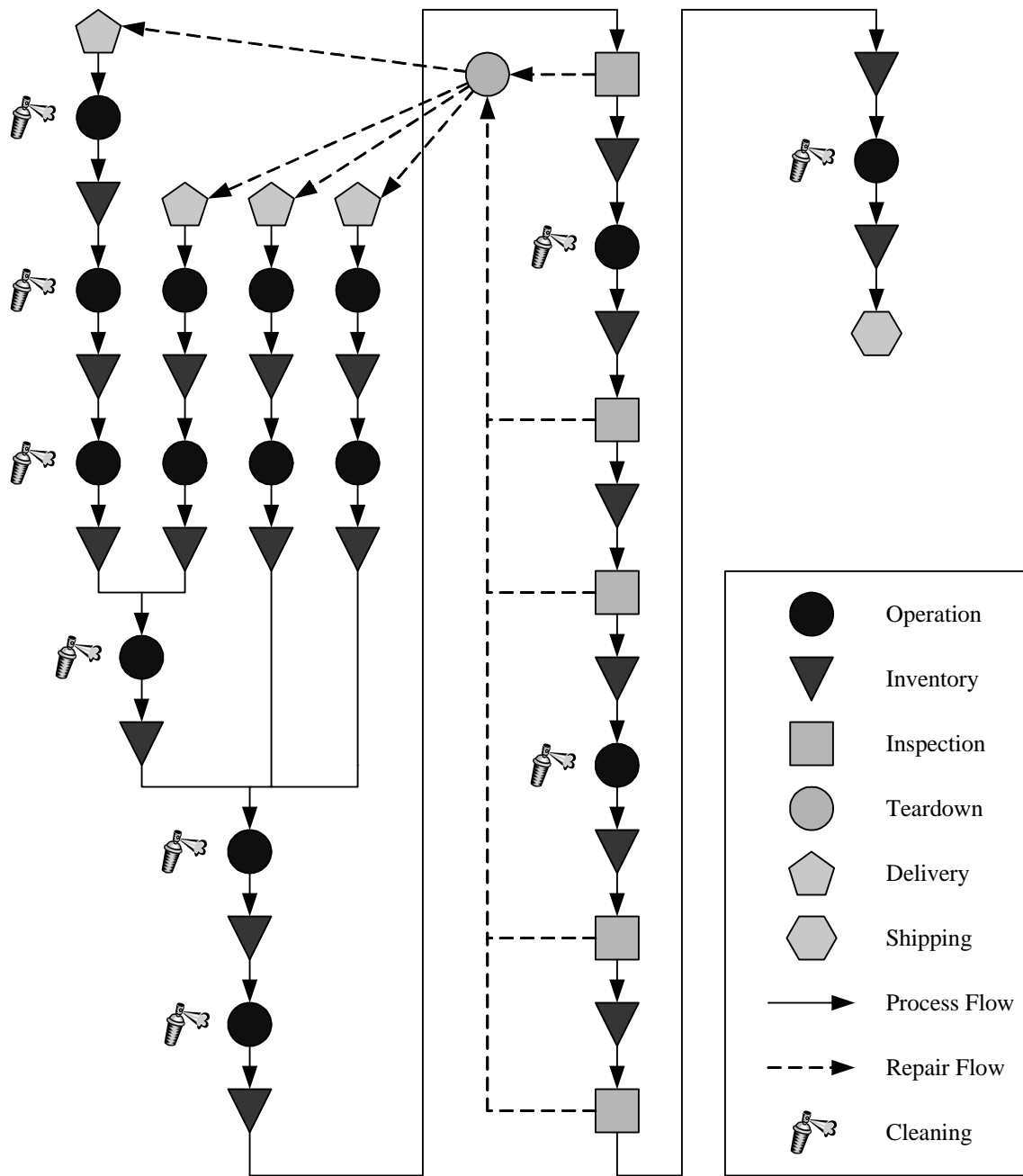

**Figure 39: Manufacturing Process Flow For DCS 760**



In addition, there is a high level of attention paid to the avoidance of particulate contamination at each process operation. The entire production system occurs inside of a cleanroom, and all operators are required to wear gowns, hairnets, safety goggles and booties, in order to reduce the level of particulates in the surrounding air. In addition, each operation occurs under a HEPA-filtered laminar flow hood, which forces particulates away from the working area. Finally, at each stage of the process, all components involved with the assembly are cleaned using alcohol wipes, canned air, and dust-free brushes, further reducing the chance that internal contamination will be introduced.

Generally, the DCS 760 camera production process has proven adequate for the needs of the department. Production output is relatively steady, cameras are produced to uniform standards, and major quality defects are captured in the process rather than released to the field. The process has become mature and operators have become highly trained experts in their specific tasks.

However, this process does have several disadvantages that hinder its performance. These deficiencies result in increased costs, decreased throughput, dramatic rework levels, and longer leadtimes.

First, due to the extreme range in product settings (10-20 different shutter speeds, 4-6 different film speeds, 3-10 different aperture settings, 1-4 different lighting conditions, etc.) there are literally thousands of combinations that require testing. In addition, for each of those camera settings, many performance metrics (hue, saturation, contrast, sharpness, focus, etc.) are used to evaluate the camera's performance. Eastman Kodak's customers typically operate the DCS 760 at the extremes of performance, therefore many of the possible configurations of the camera are tested to ensure proper functionality and performance. As a result, the testing and calibration operations can take up to four hours to complete the testing of a single camera, and are therefore the process constraint.

In addition, due to the thousands of items being checked, and the many performance metrics that must be examined for each of those settings, the probability of finding one unsatisfactory element is very high. Because Eastman Kodak is committed to ensuring no defects reach their customer, all cameras that fail any of tests are prevented from being shipped. As a result, very few cameras actually make it through all performance tests on the first attempt.

Next, because functional tests occur only at the end of the process, some defects that were actually introduced at early process steps are not found until the late stages of production. This large time delay can lead to the late discovery of product defects, and by the time a final test operation catches the defect, many faulty cameras could have been produced. This increases the chance that defective cameras can reach the final customer.

Next, when defects are found, a major effort is needed to determine the total scope of the defect. But, due to the lack of in-process tests, it is often quite difficult to determine where in the process the defect was originally introduced. And, due to the complex design of the product, it is difficult to disassemble the camera to replace the defective component, even if the responsible operation can be found. As a result, whenever a quality defect is found, the offending camera is sent back to the beginning of the process, where it is torn down and sent back through the process to be rebuilt. If process engineers suspect that the defect is widespread, all in-process cameras are disassembled and checked, thereby creating rework and wasting significant time and effort that was involved in assembling the cameras.

Next, the large levels of inventory between each process operation have the numerous disadvantages that typically accompany in-process inventory. First, the holding cost alone is significant, since each unit in inventory represents a \$10,000 camera. In addition, the in-process buffer locations take up valuable floorspace in the cleanroom. Also, the increased number of parts on the production floor severely complicates the task of product traceability.

Finally, due to the sequential nature of the process, and the assignment of specific operators to specific tasks, the ultimate output of the process is highly dependent on the output of individual stations. Because there are no parallel operations and little cross-training of operators, the absence of a specific worker or the failure of a specific piece of equipment stops the entire process and prevents any cameras from being produced.

These drawbacks obviously increase the overall cost and complexity of the production system. However, since product customers were mainly concerned with product quality and consistency, there was not much pressure on process engineers to change the process. Because production volume was low, the complexity of the DCS 760's manufacturing system was tolerated. And, because the production system ensured that only perfect quality and uniformly consistent cameras reach the end customer, the main requirements of the system were being met, reducing the need to change the process design.

### **The Manufacturing of the DCS Pro 14n Camera**

Recently, Eastman Kodak developed their newest high-performance camera, the DCS Pro 14n. This camera utilizes the latest in imaging technology, a CMOS based image sensor that captures images at resolutions up to 14 Megapixels<sup>145</sup>. This performance allows photographers to capture images that show more than twice the detail as images recorded by other cameras, while offering numerous other benefits, as described in Appendix C.

---

<sup>145</sup> Most digital cameras use a CCD based image sensor.

The DCS Pro 14n is Kodak's first professional camera that was designed exclusively as a digital camera. Through a licensing agreement with Nikon, the patented Nikkor AF lens mount has been used on the 14n. The overall package of the camera is much more compact, since the unneeded components required only for a traditional film camera have been removed. In addition, since the camera is a fresh design, many of the components of the camera were designed to be highly modular. These modular components will allow the 14n to be a platform for future models, since specific components can be swapped out with parts that utilize more updated technology.

Not only has the move to a CMOS imager resulted in a quantum leap in performance, but also the use of the new imager has led to a significant cost reductions. The DCS Pro 14n has a retail price of \$5000, allowing photographers to purchase a highly advanced camera with more than twice the performance of current models, but at almost half the price.

Because of its incredible levels of performance and extremely attractive price, the DCS Pro 14n is expected to be highly successful in the marketplace. The camera will attract a large number of professional photographers, but will also draw a large number of advanced amateur photographers. Because of this, program managers estimated that the DCS Pro 14n should sell between 10 and 20 times the production volume of the DCS 760 camera.

Because of this higher expected volume, it was determined that the existing manufacturing system would not be capable of producing the required volumes of the product. Therefore, a project was commissioned to examine the fundamental requirements of the new manufacturing process, design a production process that would accommodate those requirements, and then physically implement that process. Due to tight timing requirements, that manufacturing process would have to be developed and put into place within 3 months.

## The Use of the Improved Process Design Methodology

Department management recognized that the scope of the process design project for the DCS Pro 14n would be much larger than any previous process design project undertaken in the department. In addition, the ultimate success of the DCS Pro 14n camera largely depended on when it first reached the market and how much of the market demand can be satisfied before competitors develop a reactionary product. Because of this, the manufacturing system had to be developed in an optimal configuration that would meet all customer requirements, while use as few resources (labor, floor space, equipment, etc.) as possible.

To accomplish this, it was necessary to use the improved design methodology described in this thesis. The remainder of this case illustration presents the main progress that was made in each of that process' stages.

## **Solicit Input From Required Support Activities**

It was clear that the production system for the DCS Pro 14n would require support from many different functional areas. Some areas would be involved in the support of daily operations, others only when problems arose, while other areas would be needed to ensure the process elements satisfied company regulations pertaining to environmental, ergonomic, and safety issues.

Because of this, the chief process designer assembled a cross-functional team as soon as management commissioned the design project. The team involved representatives from Manufacturing Engineering, Quality Assurance, Material Handling, and Logistics (Shipping & Receiving). In addition to these traditional areas, which are likely involved in every process design project, the DCS Pro 14n design team included representatives from the following groups:

- Project Management
- Product Engineering
- Test Engineering
- Health, Safety, and Environmental Engineering
- Facilities Engineering (power, water, air, construction, etc.)
- Hourly Operators, Team Leaders, and Supervisors

Project management was involved because the launch of the manufacturing system would be a major factor in determining the market availability of the product. As a result, the design and implementation of the process had to meet strict scheduling milestones in order to ensure the launch would occur when planned.

Product engineering was involved due to the revolutionary nature of the DCS Pro 14n. Since the camera used an entirely new design, it was likely that multiple design changes would be required to account for manufacturing and assembly issues. In addition, the product engineers were eager to receive feedback on the performance of the product during manufacturing, so their involvement with the process design project was critical.

Test engineering was involved at a very detailed level due to the use of a new type of imaging sensor. Entirely new test routines were needed to examine the performance of the CMOS sensor and the functionality of the camera. In addition, since the test operations were historically the process constraint, test engineers were involved in designing the process so the test constraint could be eliminated, or at the least minimized.

Health, Safety, and Environmental Engineering was involved to ensure that the new process would meet all corporate requirements regarding regulated areas. Facilities Engineering was included so that any necessary changes and modifications to the building infrastructure could be identified and completed early, minimizing the impact on the project's schedule.

Hourly Operators, Team Leaders, and Supervisors would prove to be the most integral group of the design team. These individuals were the people most closely linked to the assembly of the camera, and they were the ones most impacted by the successes and failures of the production system. As a result, these individuals would have numerous ideas of how the existing production process could best be modified, and what would constitute an “ideal” production system.

Including all of the functional areas in the production system design process would be a critical factor in the overall success of the design project. Each group would bring unique ideas, concerns, and requirements to the team. By identifying these elements early in the design process, the team would avoid having to make late modifications to accommodate for a new consideration. This would save the design team time and effort, and would allow the production system to meet the aggressive schedule.

### **Formulating The Problem**

The design team began by formulating the key challenges facing the team. The team identified the following issues:

- The current design process has inventory buffers between each and every process operation, even if the downstream operation is not a process bottleneck. As a result, the production system operated in a push environment, rather than the efficient pull environment. A better production system would eliminate these in-process inventory locations and only have one buffer ahead of the process constraint.
- Contamination still is a major problem in the production area. As a result, internal components must be cleaned at each process operation, before the assembly tasks are performed. To address this, the team suggested that operators wear gloves and face shields (in addition to the hairnets, gowns, goggles and booties that they currently wear), and that better cleaning devices (wipes, solvents, etc.) are utilized in the cleaning operations.
- Part traceability on the production floor is a major issue. At any given time, it is difficult to know what cameras are being assembled or where in the assembly process those units are. Also, it is difficult to determine the status of subcomponents, and as a result, stockouts of key components sometime occur without the material handling department being aware. As a result, the team believed that a more sophisticated material handling and tracking system was needed for the new process.
- When cameras are rejected by the final functional tests, they are sent to the beginning of the line where they are disassembled into their core components and then rebuilt into new cameras. Many of these cameras then fail for the same defect when they reach the test station again. However, there is no system in place to discover these repeat failures. As a result, the functional tests continually test a camera with the same defective parts, and valuable time of the process constraint is taken up testing these chronically bad units. To address this, designers suggested that the improved material handling and tracking system could recognize these systematic failures and prevent subsequent retesting of the same failed components.
- Several of the functional test operations actually test the same features and functions of the camera. This is to ensure that product defects do not reach the final customer. However, there is little correlation that is performed between these test stations to ensure that all tests compare performance to the same standards. Occasionally, one test station will pass a camera while the other station fails the camera. When this occurs, it is difficult to determine

if the discrepancy is due to differences in the test stations, the operators performing the test, or if the product has somehow degraded in performance between the two tests. To address this, the design team believed the tests should be automated, use automatic and uniform calibration routines, and be linked to a monitoring system that continuously checks the correlation between the test stations.

The process team identified many other similar issues, most of which were actually problems that hindered the performance of the DCS 760 production system. For many of these issues, the design team already had identified concepts that would address and solve these issues.

Before acting to implement these solutions, the team took the time to reexamine the problem and look at the issue from a wider perspective.

### **Broadening The Scope of The Problem**

After developing the previous list, the design team realized that their thinking was too constrained and biased by the current design of the DCS 760 production system. The team originally thought that just by addressing the shortcomings of that system, the revised design would be adequate for the DCS Pro 14n. However, the new production system had to be radically different, in order to produce fifteen times as much production using the same amount of operators and a decreased amount of floorspace. Incremental changes would not be enough...a quantum breakthrough was needed.

The design team then broadened the scope of the problem and developed the following challenge statement:

This design team will develop and implement a breakthrough manufacturing process for the production of the DCS Pro 14n camera. This process will be capable of producing X cameras per day, using no more than X labor hours per camera, and no more than X square feet of cleanroom space.<sup>146</sup> The production system must ensure cameras produced have the highest performance of any digital camera produced by Eastman Kodak and are built to the same stringent quality standards as other Kodak products. In addition, the new manufacturing system will incorporate powerful, yet simple, information technologies that will assist in the tracking, testing, and calibration of the cameras as well as help monitor and diagnose the status of the production system's performance.

This problem statement, while much less precise than the actionable items originally selected by the design team, dramatically expanded the team's thinking. While the DCS 760 production system would still serve as a valuable source of information, its design would no longer form the foundation for

---

<sup>146</sup> The exact production capabilities and performance levels of the DCS Pro 14n production system are confidential and controlled by the Eastman Kodak Company.

the DCS Pro 14n system. The team was now free to consider new concepts that would allow the fundamental problem to be addressed and attacked.

### **Gathering Key Inputs**

Once the team had formulated the problem statement, it set about collecting the key inputs that would provide the necessary information to develop a detailed design concept.

The “P” (Product) inputs were quite straightforward. Because DCS 760 camera was being discontinued, the DCS Pro 14n would be the only SLR camera to be produced in the department. Since there was only one version of the DCS Pro 14n, no other variations existed and all equipment involved in the production of the camera could be dedicated to producing one type of the product. This would greatly simplify the design of the manufacturing system.

The “Q” (Quantity) inputs were less straightforward. Demand forecasts placed the expected order volume anywhere between ten and twenty times the peak order volume for the DCS 760 camera.<sup>147</sup> Because the DCS Pro 14n was such a revolutionary camera, no competing products existed in the marketplace. Therefore, external demand benchmarks could not be developed and demand forecast had to be based largely on customer surveys and focus groups. As a result of this uncertain demand, the design team would have to develop a production system whose output could be easily scaled to account for large variations in demand.

Determining the “R” (Routing) inputs was straightforward. Because the DCS Pro 14n was design to exclusively be a digital camera, the complexity of the camera was greatly reduced from the DCS 760. Much attention had be paid to improving the manufacturability of the camera, and as a result, many intricate components were removed or integrated into modular subassemblies. The manufacturing of the camera was transformed into a sequence of simple assembly tasks followed by a number of complex (yet automated) quality inspection stations. The design team was therefore well aware of what steps were involved in the production of the camera, but was not yet sure how those steps would be allocated between specific process operations. The exact division of tasks would be performed during later stages of the process.

The identification of the “S” (Staffing) inputs was difficult because of the imprecise volume forecasts. To account for the wide variations in the total production levels, the design team again recognized that the manufacturing process must be flexible. The process must be able of easily adding and removing production capacity as demand requirements change, and therefore process staffing requirements would need to be flexible as well.

---

<sup>147</sup> The exact order volumes of the DCS Pro 14n production system are confidential and controlled by the Eastman Kodak Company.

The collection of the “T” (Time) inputs involved calculation of required cycle times, delivery frequencies of key components, and shipment rates of end products. To identify these requirements, the design team used the most demanding production volume projection. If the process was designed to meet that volume demand, it could then be scaled back to meet other production volumes.

For all key inputs, the design team clearly stated the desired levels of performance. Some of these levels were based on desired improvement from the current production system, while other levels were based on management targets. The identification of these performance levels was vital so objective metrics could be set that would allow specific monitoring and evaluation of the process improvements.

In conclusion, the design team was able to identify the key inputs that would largely influence the design of the DCS Pro 14n’s production system. Once these inputs were known, and the problem was carefully (yet broadly) defined, the design team was able to develop different design concepts that would meet the project requirements.

### **Brainstorming Concepts**

The design team generated numerous concepts by utilizing multiple brainstorming techniques. Each team member developed individual concepts and these ideas were then synthesized and developed into further designs. In total, over fifty design concepts were developed.

Some concepts involved the design and layout of the entire production system. Other concepts focused on small aspects of the system, such as novel ways to perform functional tests or transfer parts between stations. Some concepts called for full-automation of the entire production process, while many other concepts utilized exclusively manual labor.

When taken together, the team had a tremendous assortment of fresh ideas that could be developed further into detailed designs. The breadth and depth of these ideas confirmed the value of properly formulating the design problem and then broadening the scope of that problem. The diversity and simplicity of many of the ideas developed were vastly improved over the initial list of improvements that the team identified at the start of the process.

### **Screening Concepts**

The team then screened the initial set of design concepts according to multiple criteria. As much as possible, this screening was performed using objective metrics. This avoided team member’s biases and ensured the selected concepts actually address the key requirements of the design project.

Several ideas were eliminated because they were too complex. For example, a fully automated production system could produce cameras with very high quality and avoid particulate contamination, but it would have been very difficult to add incremental volume if actual demand exceeded the projected



level. In addition, the control algorithms needed to manage and maintain a fully automated system would introduce a level of complexity never before used in this department.

Other ideas were screened because they were too costly. One concept called for a modification of the image sensor to facilitate accurate positioning of the imager in the camera. However, to incorporate this change, the design of the sensor would have to be radically altered. This change would have required a significant capital investment and, although the concept was extremely promising, it had to be abandoned due to cost reasons.

In addition, other concepts were eliminated due to the excessive time required to develop and implement them. For example, one design concept called for the transition of functional test software platform from its current program to a software application developed and used throughout the Eastman Kodak Company. The common program had several benefits, since it was supported by a central development organization and utilized streamlined and automated test procedures. However, a significant learning curve for the new program existed and would have taken the Kodak engineers several months to become comfortable with its use. Therefore, the existing test platform was carried over because there simply was not enough time to learn and implement the corporate-supported program.

Therefore, during this stage, ideas were evaluated based on simplicity, cost, how well they addressed the fundamental requirements of the project, and the time it would take to implement them. Once the set of ideas had been reduced to a manageable set of defined concepts, the team revisited the original problem formulation to ensure that concepts met all of the goals of the project and met the goals in the simplest possible way.

### **Determining Physical Flow**

At this stage, the design team began to formalize the process design concepts. One of the first steps involved the development of the Physical Flow Chart, which showed the distinct process elements involved in the production of the DCS Pro 14n. In addition, the Physical Flow Chart categorized each process element into one of the fundamental element types, determined the required sequence of process operations, and also identified the external support activities that would interact with the production process.

The Physical Flow Chart developed for the production system for the DCS Pro 14n is shown in Figure 40. Several key elements of the Physical Flow Chart show how the design concept for the DCS Pro 14n camera was radically different than the system for the DCS 760.

First, in the new process there was only one location where in-process inventory could be stored. This location was positioned slightly upstream of the process constraint (Inspect Camera Functionality).

By having only one location where inventory could be stored, overall holding costs were reduced, part traceability was simplified, risk exposure to quality issues was decreased, and overall floor space required was diminished.

Next, many functional tests now occurred earlier in the production process, while components were still at the subassembly level. This increased the probability that defects will be caught early in the process, and relieved the downstream functional tests of some of their burden.

In addition, the separate repair and teardown process was eliminated. In the DCS 760's production process, all defective cameras were brought back to the beginning of the process, for disassembly and rebuild. This practice had numerous disadvantages, such as the need for a complex part traceability system and the creation of a large time delay between the assembly and the repair operations. In the DCS Pro 14n's production process, all teardown and repairs occur at the bench where the problem is found. Each operator has the tools and knowledge to recognize, diagnose, and fix any quality issue. The result is an immediate discovery of quality defects and a much simpler treatment of defective parts.

Next, there is only one cleaning operation, which now occurs immediately prior to the final assembly of the components. This step still ensures that particulate contaminations are removed from the imager and other sensitive components, however by only having one process step where the components are cleaned, a tremendous amount of processing time is saved.

In addition, the process became much less sequential by taking advantage of the improved (and more modular) product design. Tasks involved in building subassemblies were now much simpler, thereby reducing the dependency of a specific process on a specific operator. Cross-training could be employed, allowing operators to move between operations as needed to fulfill demand fluctuations.

The exploration of many intricate issues was involved as the design team developed the Physical Flow Chart. Through the completion of this task, the team reached greater awareness of the process, each element in that process, and how that process interacted with external support activities.

### **Determining Informational Flow**

In conjunction with the development of the Physical Flow Chart, the design team also developed the Informational Flow Chart. This Chart shows the major flows of information between process elements, and categorizes those elements according to their core functions. Like the Physical Flow Chart, the Informational Flow Chart also showed how the production system interacts with other supporting activities.

The Informational Flow Chart developed for the production system for the DCS Pro 14n is shown in Figure 41. There are five major flows of information within the DCS Pro 14n system. By carefully identifying these flows and categorizing the type of each process element involved with the flow of

information, the design team was able to completely define the major components of the informational flow system.

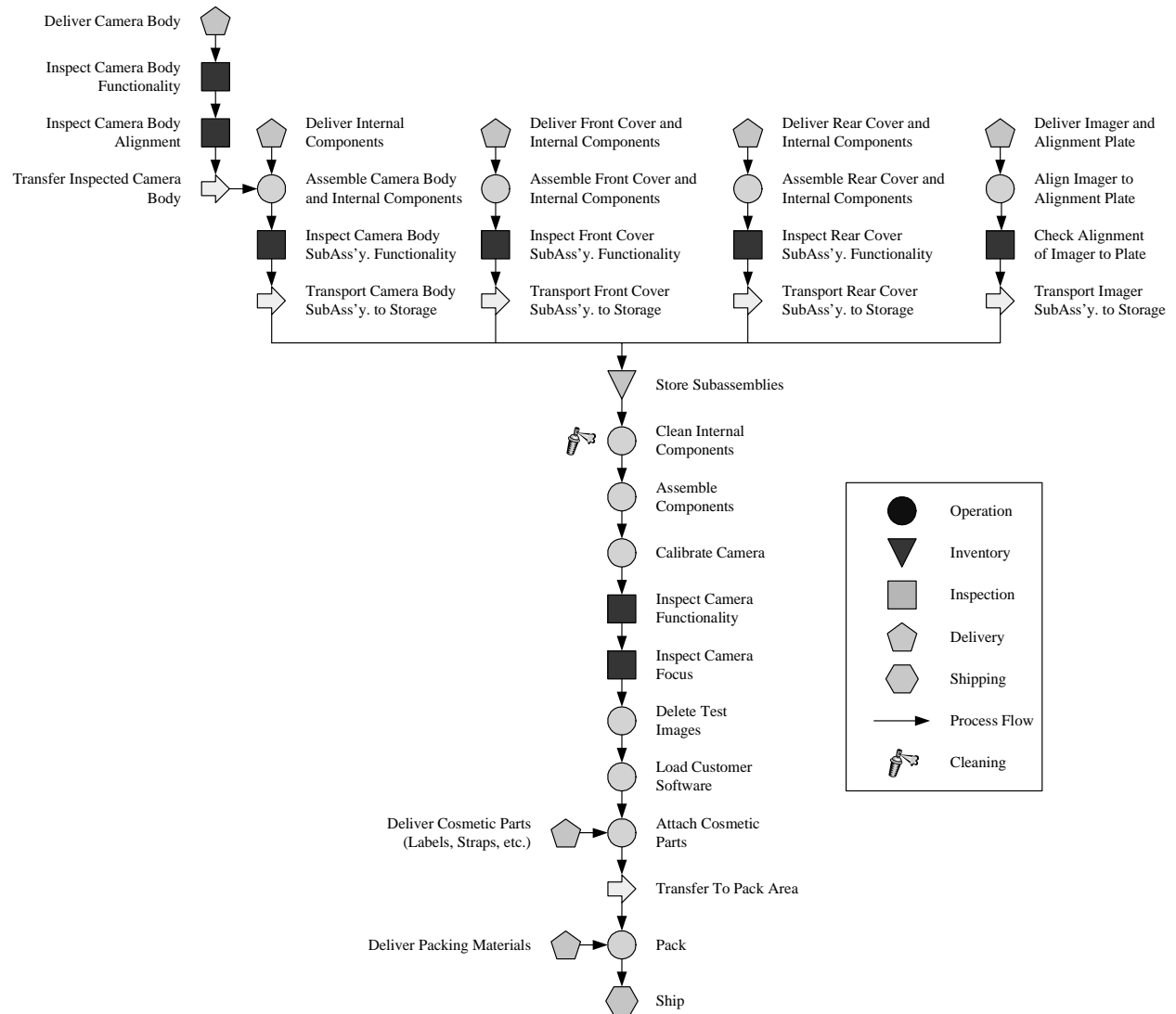

**Figure 40: Physical Flow Chart for the Production of the DCS Pro 14n**

The first flow of information consists of the sharing of information regarding the overall process status. This flow begins with the delivery of the production demand schedule to the packing operation. After inspecting the schedule for accuracy and completeness (and then completing its operation), the shipping operation issues a demand to the immediately upstream station, in this case the packing operation. This operation inspects the requirements and produces parts to satisfy the demand. The schedule requirements are then flowed back through the system to communicate the need for additional production. Communication is passed in this manner back to the subassembly operations, which monitor the current inventory levels from the central inventory location and produce parts when there is space

available in the kanban locations. This information flow therefore creates the “pull” production system, where operations only produce parts when their downstream stations require parts.

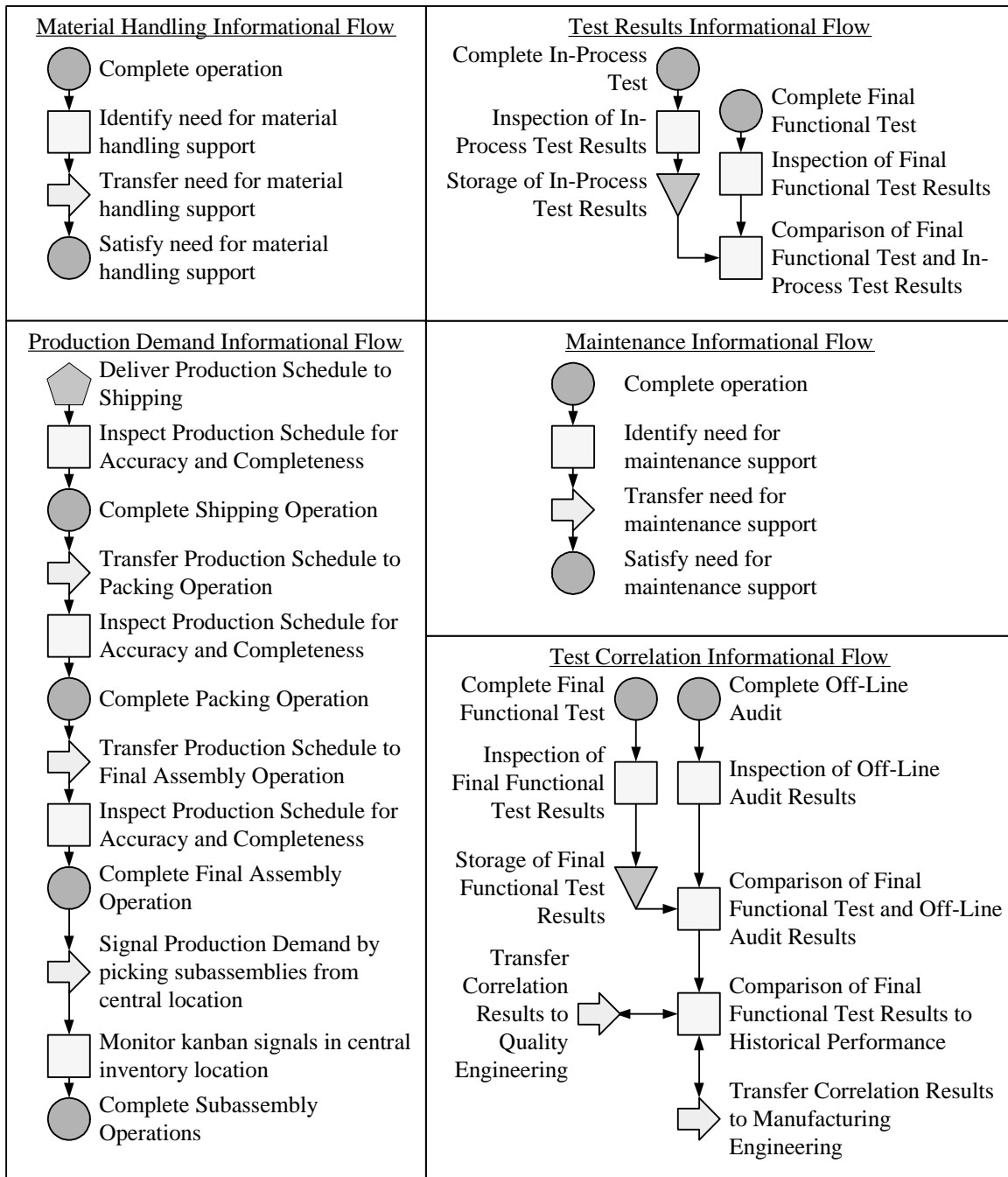

**Figure 41: Informational Flow Chart for the production of the DCS Pro 14n**

The next informational flow involves the sharing of test results between the in-process and the final functional test stations. This communication is needed to ensure that quality parts are being produced and any defective components or subassemblies are identified and contained as quickly as

possible. To accomplish this flow, the upstream in-process test gathers information and stores it in a central database. Later, when the same part is inspected at the downstream test station, the data is retrieved from the central location and compared to the downstream results. If the two tests agree, the part is released. Otherwise, action is taken to further diagnose the discrepancy in test results.

The third informational flow involves the signaling of the need for material handling at one or more process operation. In this flow, the operator notifies the material handling personnel to either bring new or take away completed parts from the operation. This flow is fairly straightforward, since the operator merely flows their request to the material handling department, who then takes action to address the issue. The fourth informational flow, which deals with the diagnosis and repair of process equipment, is quite similar, except it involves the maintenance department.

Finally, the fifth major informational flow path is between the final functional test station and the offline quality audit that is performed by separate quality assurance personnel. The audit test performs the identical tests to those performed by the final functional test and its purpose is to monitor the effectiveness of the final functional test and to ensure that the performance of the test equipment has not degraded over time. Because of the close link between these processes, there is a continual flow of information back and forth between these operations, the quality engineering department, and the manufacturing engineering department.

These information flows were all identified by the process design team early in the design process. By discovering the need for these flows, the design team was able to develop a process design that optimized the flow of information. In addition, the informational flow paths were simplified and combined with other elements, so the overall informational flow system was kept as simple as possible.

### **Determining Physical Requirements**

Once the flow of physical material had been formally identified, the design team calculated the amount of time that the completion of each process element would take. This was accomplished through the use of computer simulation and the completion of a number of time studies where operators simulated the assembly of different components. Using the overall cycle time that was calculated earlier, the design team was able to determine which operations should be grouped together in order to achieve level production throughout the process.

It was found that because of the improved design of the DCS Pro 14n, several complicated assembly steps needed to make the DCS 760 were no longer needed. Several other steps now took much less time to complete because of the many improvements in manufacturability. Entire workbenches could be removed from the process and the remaining work grouped into logical units where entire subassemblies were constructed.

It was also discovered that the routines involved in functional test operations took a much longer time for the DCS Pro 14n than they did for the DCS 760. This was mainly due to the longer time it took to download the image files from the camera, due to their increased file size. As a result, one individual test station would no longer be capable of meeting the required cycle time and therefore, several functional test stations would be required.

Thus, due to the major improvements that were made to the design of the camera, many workstations were removed or combined. But due to the increased testing time, more final test stations were needed. The end result was a net decrease of two workbenches and a slight decrease in the number of operators needed to fully staff the process.

By conducting this step of the process design, the design team was able to identify how many of each process element, and how many operators, would be needed to meet different volume demands. In addition, they recognized process operations could be combined, eliminating the need for separate workstations and inventory buffers between stations. Overall, the resulting process design became simpler and more straightforward, while still meeting all of the project requirements and constraints.

### **Determining Informational Requirements**

In a similar manner to the calculation of the physical requirements of the process, the design team determined the volume and frequency of communication associated with each transfer of information. The team determined which specific sets of data would be passed and defined the structure and format of those data flows.

For example, the new production system would utilize several in-process tests that were now performed at the subassembly level. Consequently, the results from these tests would have to be communicated to the final functional tests, so that the total test results for a specific camera could be synthesized and stored in one central location. The team had to define the structure of data for each test and determine where that information must be sent.

The new CMOS based sensor used in the DCS Pro 14n had numerous performance characteristics that differed from the DCS 760's CCD based sensor. As a result, the design team recognized that new functional test and calibration algorithms would be needed. Also, these new test protocols would generate much more data, due to the size and complexity of the imager sensor itself. Therefore, the informational flows associated with the sharing of test results would have to be expanded to accommodate the increased volume and complexity of data.

In addition, the design team discovered that communication between subassembly operators would have to increase in order to achieve synchronized production throughout the line. Operators would

have to be continually aware of current inventory levels, as well as current production demand volumes. Therefore, the production system needed an information network that could meet this requirement.

The completion of this step was vital to the ultimate success of the process design. During this stage, the design team continually examined the requirements for information and questioned whether the current concept met those requirements in the simplest manner. By doing so, several complicated uses and flows of information were simplified, and the overall system was realigned so it more closely met the needs of the users, as well as the overall needs of the design project.

### **Creating Physical Flow Relationship Chart**

The design team recognized that because the new process design is less sequential than the DCS 760 production process, the level of interaction between process elements increased and became more complicated. No longer would each process element be solely concerned on whether enough parts were available to produce its assemblies. Process elements now must ensure that their production is closely tied with the production levels of other elements, and inventory levels are kept under control.

As a result, the team constructed the Physical Flow Relationship Chart, shown in Figure 42, to identify the major relationships between process elements.<sup>148</sup>

Several key relationships become apparent from reviewing the Physical Flow Relationship Chart. The relationships were more complex than those shown in the Physical Flow Chart. Therefore, their identification gave the team significantly more insight into the dynamics and behavior of the manufacturing system.

First, there is a large amount of interrelationship between most process elements. This high level of connection shows that an optimal process design would allow these many process elements to be located quite close to each other. Their close proximity would permit easier flow of material, common use of operators, and greater awareness of overall process performance.

Next, there are a few select process elements that must be located far from the rest of the process. Most of these relationships involve the final functional test station. In the DCS 760's production system, this final functional test was placed in line with the other production operations, and as a result, all cameras had to pass through the test station before they could be packed and shipped. The original intent of this station was to function as an audit station where random samples of cameras were periodically checked. However, since it was part of the process, 100% of the cameras had to pass through it. Although this ensured no defects escaped the factory, the testing of each camera could take up to 6 hours, and therefore, the ultimate output of the process depended on the output of this quality "audit" station.

---

<sup>148</sup> For clarity, the squares for process elements that are unrelated relationships have not been filled in.

For the DCS Pro 14n camera program, the process could not afford to have an in-process operation take any longer than one hour, much less six. As a result, the design team consciously chose to keep this final test station away from the normal process flow. Even though cameras were periodically taken out of the process to be checked, normal production could still flow to the pack and ship operations.

Next, the Chart shows that there is a high level of relationship between the various delivery, transfer, and storage process elements. These relationships reflect the fact that the process will operate in a kanban-signaled, pull type manner, where subassemblies are only produced if space is available for them at the central storage operation. Process operators will now have to carefully monitor the levels of subassembly inventory, and only complete assemblies when needed. If their subassemblies are not needed, the operators will move to other process operations to produce any subassemblies that are needed. This policy is much different (and much more efficient) than the practice used on the DCS 760 program, where operators produced parts as quickly as possible regardless of current inventory levels.

Finally, the Relationship Chart shows the close relationships between subassembly operations. The high proximity ratings reflect the intent of the design team to have process operators shift from one subassembly operation to another with regular frequency. This rotation allows the operators to remain interested in the assembly process, as well as raises their understanding and awareness of issues that affect the overall product and process. In addition, by having the subassembly stations close together, the overall floor space required by the process is minimized.

Thus, the Physical Flow Relationship Chart has identified many relationships between process elements that had not been identified in the Physical Flow Chart. The use of this Chart therefore allowed the design team to increase their understanding of the needs and requirements of the production system, as well as recognize issues that would greatly influence the overall design of the manufacturing process.

### **Creating Informational Flow Relationship Chart**

In a similar manner, the design team soon recognized that the informational flows involved in the production of the DCS Pro 14n were dramatically different than those of the DCS 760 production process. The 14n's process now involved upstream in-process subassembly tests as well as final functionality tests. As a result, complex links were needed between those tests to ensure that all necessary parties had access to all pertinent information. In addition, the operation of the DCS Pro 14n production line required much tighter coordination between external support activities, such as material handling, quality assurance, and logistics. This added coordination was needed to ensure that the proper number of parts were delivered and shipped at the right time, in the right quantities. As a result, the design team needed to document the required informational relationships between all process elements, as well as between the process and the external activities.





For example, the Informational Flow Relationship Chart shows that all delivery, transfer, and material storage process elements are closely linked. The need for close relationship reflects the need for an integrated approach towards material handling tasks. Rather than having each operator individually responsible for setting his or her own production rates and inventory levels (as occurred with the DCS 760 process), each process element involved in handling material would now be tightly linked together.

Next, the Relationship Chart shows how all inspection steps, whether they are in process, final, or off-line quality audit tests, must be strongly linked in order to share information between the operations. The sharing of the test results allows diagnosis of quality issues earlier in the production process, as well as systematic analysis of product performance.

Also, the Informational Flow Relationship Chart illustrates the need for continual information flow between the final assembly operation and the upstream process steps that produce the camera's subassemblies. This ensures that all operators are aware of the process' status and are quickly notified if any quality issues are found.

Therefore, the development of the Informational Relationship Chart allowed the team to discover and document various informational flow linkages between process elements. These linkages differ in the level of communication that is needed between each process element pair, and whether that communication needs to be continual or only occasional. By creating this Chart, the team developed further understanding of the process and insight into the fundamental needs of the process.

### **Identifying Technical Capability Requirements**

The development of the Informational Flow Chart and the Informational Relationship Chart allowed the team to identify the major elements of the informational flow system that would be implemented for the DCS Pro 14n camera. Once these major elements had been identified, the design team determined the level of technology each element required, and what technology could be used to link the different systems.

First, to manage the collection, analysis, and communication of qualitative information, a centralized database application would be needed. This application would have to allow data entry by multiple users at multiple locations. In addition, the application would have to be capable of producing numerous performance and summary reports detailing various aspects of the process. Finally, the database application would have to allow various parties to search, query, sort, and group the data.

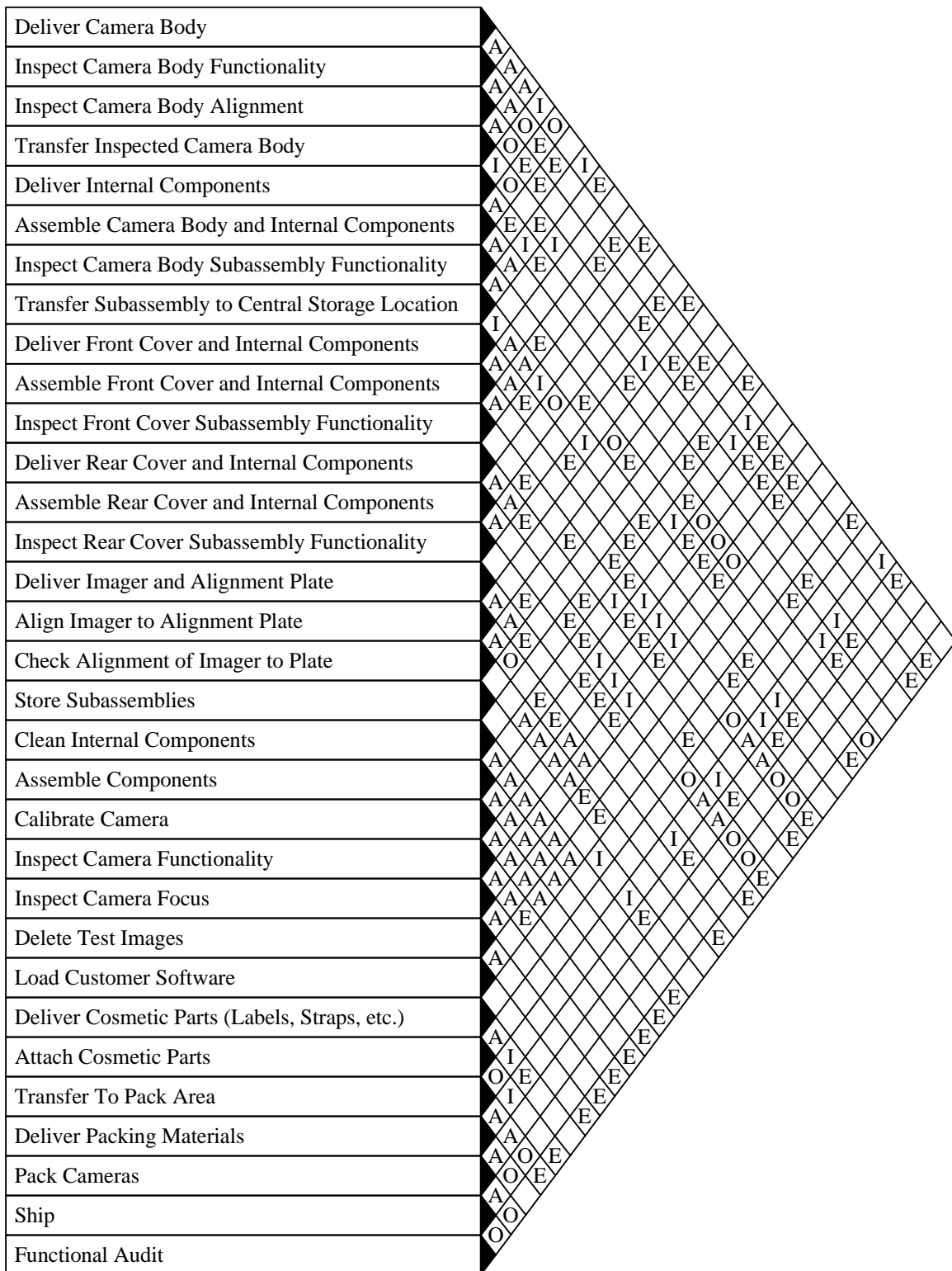

**Figure 43: Informational Flow Relationship Chart for the production of the DCS Pro 14n**

Next, to manage the collection, analysis, and communication of quantitative information, another centralized database application would be needed. This database would have to meet all of the requirements of the qualitative database, but would also have to support automatic data collection and population of the database. In addition, the database's capacity must be expandable and capable of storing numerous types of data, including picture files.

Finally, the information system must include methods and tools that would facilitate interpersonal communication and would act to raise the awareness of all operators of the process' status and performance. The team did not believe that a highly advanced information technology system was required to accomplish these needs, but the team was receptive to any novel methods that would increase communication between operators.

Therefore, by identifying the core flows of information and discovering the relationships between those elements, the team developed a sense for the level and type of technology required by the system.

### **Identifying Physical Space Requirements**

The completion of all design steps up to this point allowed the team to develop a detailed knowledge of approximately how much space the new manufacturing process would require.

Several workstations could be eliminated, because their operations were either unnecessary or could be combined with other assembly steps. In addition, all inventory locations (with the exception of the central storage location) were eliminated. This greatly reduced the floorspace required, since carts and racks were no longer needed to store cameras between each operation. Finally, because operators would now be cross-trained and at times responsible for staffing more than one workbench, the workbenches had to be placed closer together to reduce the distance the operators had to travel.

Overall, it was felt by the team that the new process would take up approximately 50% of the space used by the DCS 760 production system. With efficient equipment placement, the team could further reduce the physical space required. The fact that the new process would actually require less production space was remarkable. The new process would be producing between ten and twenty times the volume, but only utilize half the space and the same number of operators!

### **Confirming Technical Capabilities Are Available**

Based on the technological needs that were identified by the team, the designers examined the capabilities of existing informational flow systems. The team investigated whether those existing systems could be modified to meet the needs of the DCS Pro 14n' system, and if they could not be modified, what technological tools were available.

The design team discovered a comprehensive database system that had been used previously to track qualitative information related to production data. This system was thoroughly customized to meet

the needs of the department and most operators were knowledgeable and comfortable with its use. Because of this, the design team chose to update this software so it could be used on the Pro 14n's system to record and display qualitative information. Therefore, the major need to have a networked database capable of supporting multiple users while collecting qualitative data was satisfied.

The design team was less successful finding an existing system that would record quantitative information. The team discovered that numerous process elements already had advanced information collection and analysis programs, but each of those programs were custom built, complicated, and were not networked to other operations in any meaningful way. In short, these programs were concrete examples of the "Islands of Automation." In order to have a fully networked system that shared quantitative information, these elements would have to be revised. In order to share information between process elements and allow the power of the information to be effectively used, some software applications would have to be written and an overall repository database would have to be created.

Finally, the team found direct communication between operators could be achieved with effective design of the process layout. Workbenches placed strategically would allow operators to maintain "line of sight" communication with other operators, enabling face-to-face communication. No advanced technology would be required to achieve this level of interaction. In addition, the use of the one central location for subassemblies would ensure that operators continually interact when they place or pick up their parts from the racks. This repeated communication would ensure that each operator becomes well informed about the overall status of the line, its quality levels, and the critical issues of concern.

Therefore, the design team identified that the existing database for qualitative information could be simply modified to meet the needs for the DCS Pro 14n. A new database system and data collection programs would be needed for collecting, analyzing, and sharing quantitative information. But no advanced technology would be needed to improve communication between operators.

### **Confirming Space Required Is Available**

As mentioned, the team was confident that the floor space required by the DCS Pro 14n production system would be approximately half the space used by the DCS 760 process. Once this was determined, the team had to identify the optimal location in the clean room for the process.

Because production of the DCS 760 camera had already ceased, the team selected to install the new process where the DCS 760 used to be located. Minor facilities modifications would be required, but this space offered numerous benefits, including its close proximity to the shipping and receiving areas.

Once this space was allocated to the DCS Pro 14n, the team developed the Physical Flow Block Layout Diagram.

### **Creating Physical Flow Block Layout Diagram**

Once the design team had identified all process elements, the sequence of those elements, and the flow of material and information through those elements, the basic layout of the manufacturing process could be developed. Then, when the complex relationships between the process elements were identified and finally when the physical space requirements were agreed upon, it became fairly straightforward for the designers to develop a process layout. After a few iterations, the design team developed the Physical Flow Block Layout Diagram that is shown in Figure 44.

Several key aspects of the Block Layout should be discussed to show how the design team addressed many requirements of the design project.

First, there do not seem to be enough workbenches to complete each process operation. However, this is because multiple process steps have been combined into one workbench. By combining multiple process elements into each bench, the total number of workbenches was decreased, thereby reducing the total floorspace required by the process. In addition, this decreased the information lags between the functional tests and the assembly operations, because now the same operator that builds the parts tests the parts, thereby receiving immediate feedback on product performance.

Next, the flow of the process is quite simple, moving left to right through the process operations. Each subassembly process sends its completed parts to the central inventory storage location. Then, each final assembly operation takes subassemblies from the central location and completes the subsequent process steps (including camera calibration and testing). The finished cameras are then passed to the final processing station where the cosmetic parts are added, the test images are removed, and the customer software is loaded. After this final station, the finished cameras are either sent directly to the packing and shipping area, or are taken to the functional testing and audit area. The network of aisles through the process makes material handling straightforward and allows operators to freely move between operations while minimizing the overall floorspace of the process.

Next, the orientation of the workbenches was designed to create workcells where operators could move from bench to bench, as production demand fluctuated. In addition, the grouping of the benches improved face-to-face communication between operators, one of the major goals of the process.

Finally, the Block Layout Diagram allowed the design team to consider outside considerations, such as safety requirements governing ingress and egress. The process layout had to be modified to account for these considerations, even if these modifications resulted in a less than optimal process design. For example, several structural columns (initially ignored by the design team) caused slight realignment and reorientation of process equipment.

The Physical Flow Block Layout Diagram allowed the team to visualize the physical placement of the process elements without actually having to move pieces of equipment. The Diagram allowed

multiple design concepts to be reviewed and evaluated on how well each design met the project requirements. In addition, external considerations became factors in the design of the process. The resulting Physical Flow Block Layout Diagram was a fairly detailed layout drawing that the team could use to implement the process.

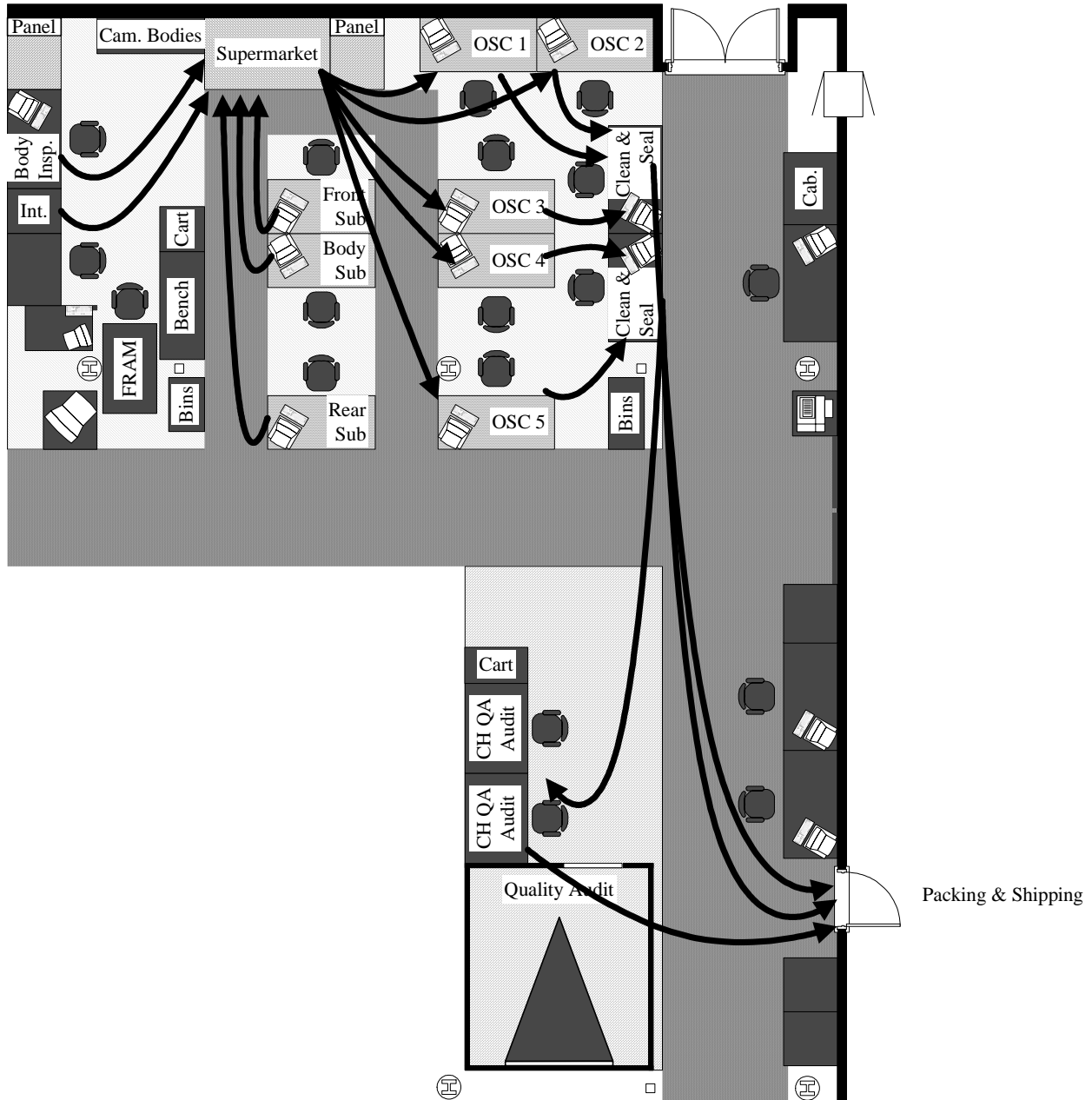

Figure 44: Physical Flow Block Layout Diagram for the production of the DCS Pro 14n

### Creating Informational Flow Block Layout Diagram

Once the design team had identified all elements of the informational flow system, and had discovered the relationships between each of those elements, the team was able to develop a system architecture drawing that showed the major linkages between the elements. The Informational Flow Block Layout Diagram developed by the team is shown in Figure 45.

The actual Diagram developed by the team was much more detailed than the one shown here. The detailed Diagram included much more information for each link and showed the structure, content and frequency for the information that was shared. However, the high level abstraction shown here can illustrate the major components of the information system.

First, two major database systems were utilized to gather and store information in the system. One database was based on a Microsoft SQL 7.0 application that was used to collect and analyze quantitative data, such as calibration settings and dimensional measurements. In addition, this database stored test images for each camera, as well as complete test and calibration records. The other database was based on the FileMaker Pro database that was used for previous camera programs. This database was used to collect more qualitative information and track the assembly of purchased components.

These two databases were linked via a custom-built software application. This powerful program allowed qualitative and quantitative information to be linked in ways never before possible. Engineers were able to track the performance of various subassemblies, thereby making it possible to identify and contain systematic quality issues.

The two databases were placed on a shared network, so the data held internally could be accessed and utilized by many different groups. For example, team supervisors used the overall production volumes to adjust the labor and staffing schedule for the remainder of the week. Quality engineers used the data to perform statistical process control and discover underlying issues related to the processing equipment. Product engineers analyzed the functional test data to ensure that the calibration routines were properly functioning. Now that the information was freely available to all these various parties, overall awareness and understanding of the process and its behavior increased tremendously.

Also, the Informational Flow Block Layout Diagram showed which links between the process elements and the databases would be managed with manual intervention and which would be managed automatically. This designation would assist the computers programmers in the development of the database interface utilities.

Finally, in addition to the two databases, the Informational Flow Block Layout Diagram also represented the new paths of verbal and interpersonal communication that occurred between operators. These communication paths ensured that operators remained continually aware of the process' status as were ready to adjust production or move to other workbenches when needed. Although this



communication did not utilize advanced technology, its inclusion on the Informational Flow Block Layout Diagram illustrated the important role it played in determining the overall success of the process.

Therefore, the Informational Flow Block Layout Diagram developed by the team allowed all parties to develop a graphical understanding of the information flows through the system, and the core informational elements that make those flows possible. The simplistic representation of the advanced technological elements facilitated discussion within the team about the use of information and greatly assisted in obtaining the full support of all design team members.

### **Evaluating Different Layouts**

The design team performed a final confirmation that the identified design concept satisfied the requirements of the design process and did not violate any physical, organizational, or informational constraints. Recall the design team's problem statement:

This design team will develop and implement a breakthrough manufacturing process for the production of the DCS Pro 14n camera. This process will be capable of producing X cameras per day, using no more than X labor hours per camera, and no more than X square feet of cleanroom space. The production system must ensure cameras produced have the highest performance of any digital camera produced by Kodak and are built to the same stringent quality standards as other Kodak products. In addition, the new manufacturing system will incorporate powerful, yet simple, information technologies that will assist in the tracking, testing, and calibration of the cameras as well as help monitor and diagnose the status of the production system's performance.

Upon reviewing this statement, the design team felt that they had successfully developed a process design that met, or exceeded, each of the needs. By clearly defining the problem statement early in the process, and by continually revisiting and reformulating that problem statement, the design team remained focused on their purpose, thereby ensuring that the final concept met all the requirements.

The team further evaluated the layout concept by revisiting each process step and examining the conclusions made by the designers. Because the designers had to act so quickly to develop the concept, they wanted to ensure conclusions were not made too hastily, and promising concepts initially dismissed did not actually solve the problem in a more elegant and less complex way. Finally, the team performed a detailed spatial analysis to ensure the design concept would indeed fit in the space selected and the information technology required by the process could actually be developed in the timeframe required.

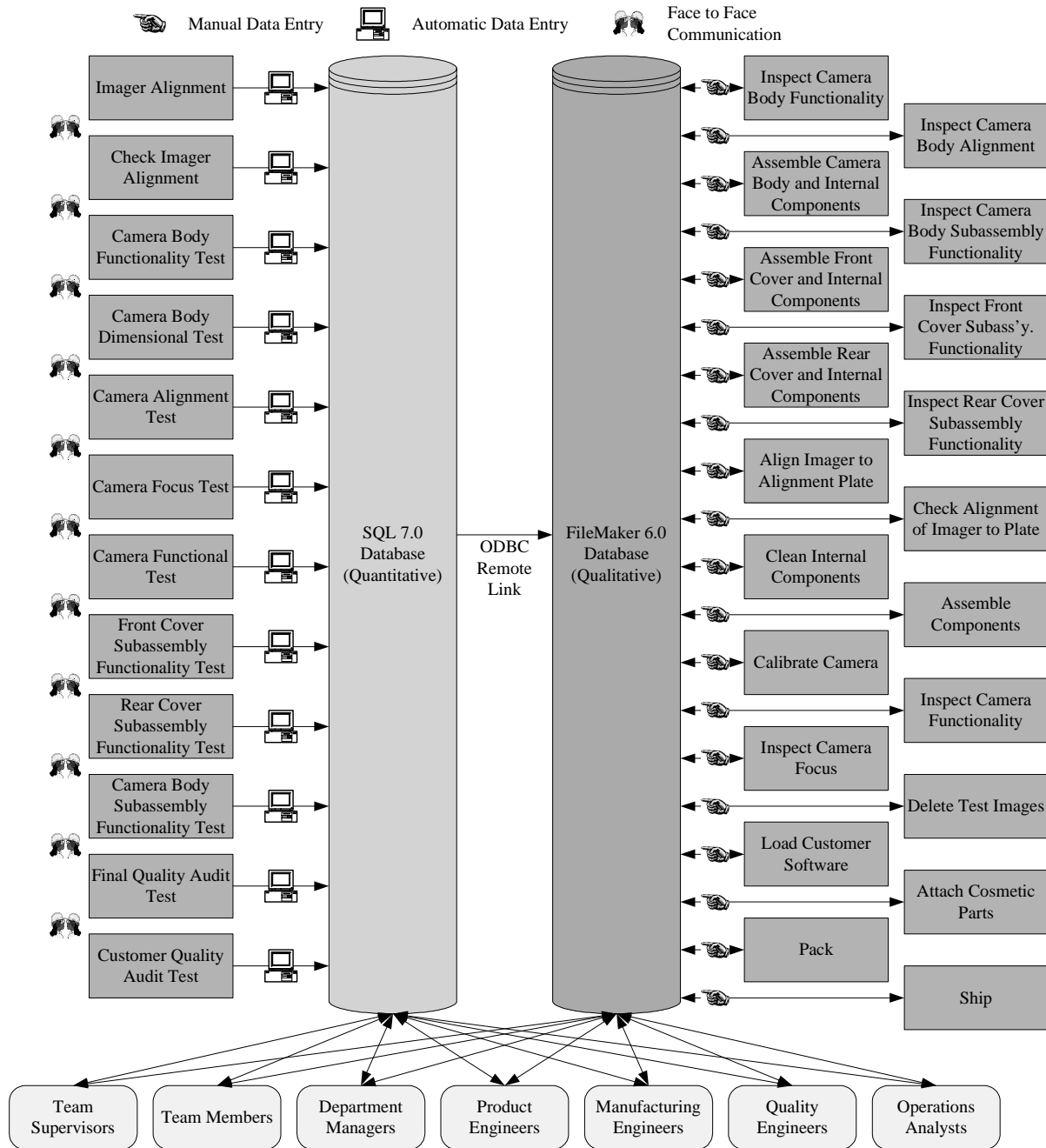

**Figure 45: Informational Flow Block Layout Diagram for the production of the DCS Pro 14n**

Because the design team had solicited input from many functional areas, and gathered this input early and throughout the design process, this process step was mostly a confirmation of the team's decisions, assumptions, and compromises. No new issues were discovered, and the team was fully confident that the process concept they had developed would satisfy the underlying needs of the project.

### Selecting Optimal Layout

Similar to the previous step, the task of selecting the optimal layout was straightforward. Because significant input was gathered early on, and due to continual reevaluation of the concept's simplicity, the design team had become fully supportive of one concept. That design was created as a result of constructing the Flow Charts, Relationship Diagrams, and the Block Layout Diagrams.

Therefore, there was not a set of concepts from which to choose. Rather, the one concept that had evolved into a detailed process was formally endorsed as the new production system for the DCS Pro 14n.

### **Installing Layout**

Over a period of a few weeks, the process design was installed. Facility modifications were made, including the addition of utility drops and network connections, and the construction of an improved area for camera performance testing. Process equipment was modified and customized for the DCS Pro 14n. Material handling equipment and storage locations were developed, and process workbenches were put into place. Finally, all equipment and material not related to the DCS Pro 14n was removed from the area. By the time the product was ready for launch, the manufacturing process was fully installed, operators were cross-trained, and the informational flow system was operational.

The design team remained intact for a few weeks after the process was installed. This enabled the team to monitor and record the actual performance of the process and compare the initial performance to the levels that the team expected. For one operation, it was found that the design team's prediction of cycle time was too optimistic. Due to the number of parts involved, it actually took longer than the required cycle time. For another operation, the team's prediction of cycle time was too pessimistic, and the simplicity of that operation's tasks allowed the step to be completed very quickly. As a result of these findings, some tasks had to be shuffled between benches in order to balance the workloads. In addition, the design team found that other minor modifications had to be made, such as the orientation of some workbenches to facilitate material flow. However, on the whole, the process was installed as designed.

Before disbanding the process design team, the team ensured that its design process was fully documented. Although the Flow Charts, Relationship Diagrams, and the Block Layout Diagrams provided an incredible amount of detail, the team also wanted to document the assumptions and compromises made, as well as the promising process design concepts screened for cost or timing reasons. This level of documentation ensured that future design teams could review the development of the DCS Pro 14n's production system and could benefit from the design team's key learnings.

### **Actual results**

The success of the DCS Pro 14n's production system can only be determined after several months of production. However, early results show that the system does meet most design requirements.

First, the physical benefits of the process are remarkable. Overall, the physical space required by the new production process was much less than the space used by the DCS 760's production process, as shown in Figure 46 and Figure 47. This dramatic reduction freed up a large amount of clean room floor space, allowing the department to develop and implement manufacturing processes for new products. In addition, the new system produces fifteen times the volume of the DCS 760 camera, but does not require a significant increase in labor resources. Therefore the "density" of the production system, as measured in terms of cameras produced per square foot and cameras produced per worker, is a tremendous improvement over any camera produced by this department.

Next, the benefits of the informational flow system have been significant. By improving communication between operations, inventory levels have decreased while overall quality has increased. Due to the improved flow of information, traceability of in-process material has been simplified. In-process and final functional tests are now linked, greatly improving the diagnosis, containment, and correction of quality issues. Also, process management and monitoring has been enhanced due to the information collection, analysis, and dissemination tools implemented in the manufacturing system.

In addition, the overall attitude of those involved in the production of the DCS Pro 14n camera has improved. Cross-training of operators has allowed the team members to perform more interesting and dynamic work, and has enabled them to interact more on an interpersonal basis. Communication has improved, and the new variety of work has raised the morale of all operators.

Finally, the success of the product itself has been greater than expected. After its debut at the Photokina show in September 2002, Eastman Kodak quickly took over 5000 orders for the camera. With the tremendously positive media exposure the DCS Pro 14n has received, it appears that even the most optimistic demand forecasts were in fact too conservative. This shows that the DCS Pro 14n camera will indeed be a revolutionary camera for Eastman Kodak as well as the entire photographic industry.

Even with these early benefits that were observed, the design team is still concerned that the performance of the manufacturing system may not be optimal. Most troubling is the feeling that the production process may not (in its current configuration) be capable of producing enough cameras to meet the higher than expected demand. The production system was originally designed to be quite flexible, capable of accommodating as much as a fifty percent increase in even the most optimistic demand forecasts. But the initial demand shock was greater than even that level, and as a result significant redesign efforts may be required to allow Eastman Kodak to capture these sales.

In conclusion, the production system for the DCS Pro 14n camera has achieved breakthrough performance improvements. A tremendous increase in capacity was achieved, however this was obtained without adding labor and while decreasing the floorspace required. A comprehensive informational flow

system was introduced, allowing for improved communication, awareness, and monitoring of the process. Finally, organizational changes were implemented, increasing the level of operator cross-training and improving the overall morale of the production team. However, even with these benefits, the production system may not be flexible enough to accommodate the higher than expected market demand.

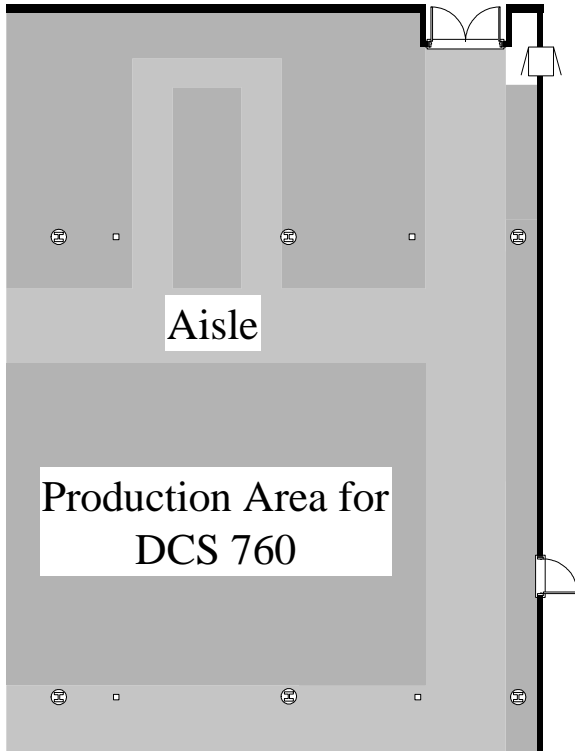

**Figure 46: Floor Space Used By DCS 760 Production System**

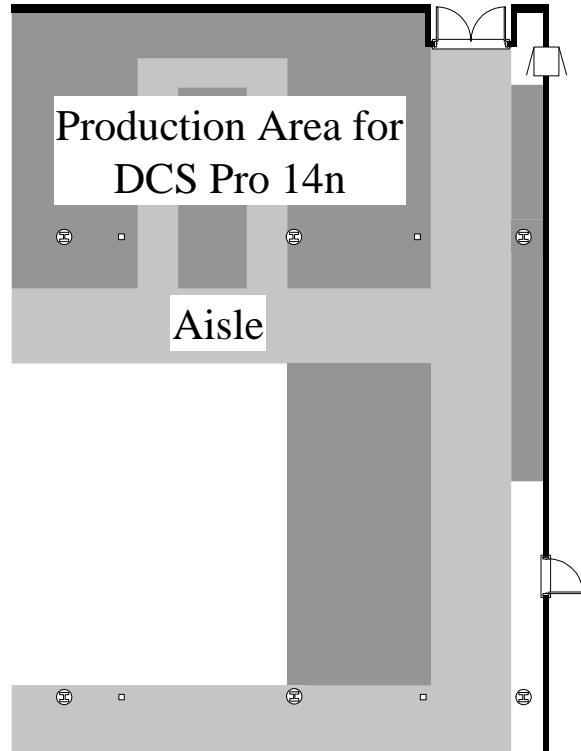

**Figure 47: Floor Space Used By DCS Pro 14n Production System**

### **Discussion**

This case illustration demonstrated how the improved design methodology was used in developing a manufacturing production system for a new product. It chronicled the process used by a cross-functional design team to create a process for the Eastman Kodak DCS Pro 14n digital camera.

The case described the major highlights of each step of the design process and showed how the use of the improved design methodology can develop a revolutionary process design that yields dramatic performance results. These numerous benefits include reduced time to develop a process design, lower costs and resources required to develop a process design, and the creation of a process design that meets or exceeds all project requirements and satisfies all constraints. In addition, by gathering input from multiple parties early in the process, continually refocusing on the underlying problem, and simplifying every element of the process, the design methodology ensures that the concept ultimately developed and implemented will be as simple as possible and will require little or no redesign after it is installed.



## **Part VII**

---

### **Conclusion**





## 22: Closing Comments

This thesis has presented an improved design methodology for use in the design and development of a manufacturing system.

This design methodology is largely based upon the traditional design methodology (the Systematic Layout Planning (SLP) process developed by Muther) combined with several other elements of traditional manufacturing process design, such as problem formulation, process simplification, and the use of lean production fundamentals.

The major shortcoming of the traditional design methodology is the lack of attention paid to the flow of information through a manufacturing system. It was shown that the traditional method focuses solely on the flow of physical material, and this single-mindedness can no longer be tolerated in today's competitive business environment.

In some manufacturing processes, the flow of information is more complicated than the flow of physical material, and often it is the sharing of information within a process that ultimately governs the process' performance. Because of this, process designers perhaps need to concentrate more on the flow of information than on the flow of material, especially as manufacturing processes become more information dependent.

The design and development of information systems typically occurs after a manufacturing process has been put into place. The result of this practice is the introduction of information management systems that are suboptimal, more complex than necessary, and extremely expensive to implement.

To overcome the lack of attention paid to information flow, the traditional design methodology must be revised so that it adequately considers the flow of information through the manufacturing system. Furthermore, not only must process designers consider information flow when developing a process, but this consideration must occur in a concurrent manner as the team develops the physical flow production system. Only by performing the design of the two systems together will process designers ensure the resulting system yields a seamless flow of information as well as physical material.

To enable the concurrent design of informational flow and physical flow production systems, three fundamental tools were introduced: the Informational Flow Chart, the Informational Flow Relationship Chart, and the Informational Flow Block Layout. By merging these elements with the traditional process design methodology, process design teams will have a more powerful, robust, and appropriate method to use in attacking their next process design challenge.



## **Bibliography**

---



1. “Concurrent Engineering Within Aerospaciale: A Practical Approach”, Jean-Michel Azon, IT and Manufacturing Partnerships: Delivering the Promise – Proceedings of the Conference on Integration in Manufacturing, Galway, Ireland, October 204, 1996, J. Browne, R. Haendler Mas, and O. Hlodversson (Editors), IOS Press, Amsterdam, The Netherlands, 1997.
2. IT and Manufacturing Partnerships: Delivering the Promise – Proceedings of the Conference on Integration in Manufacturing, Galway, Ireland, October 204, 1996, J. Browne, R. Haendler Mas, and O. Hlodversson (Editors), IOS Press, Amsterdam, The Netherlands, 1997.
3. “Essential Considerations When Incorporating Computer Automation Technologies Into Design And Manufacturing Operations”, Jacobo Bulaevskysy, Applications of Computers to Engineering Design, Manufacturing, And Management, Proceedings of the IFIP TC 5 Conference on CAD/CAM Technology Transfer: Applications of Computers to Engineering Design, Manufacturing, and Management, Elsevier Science Publishers B.V., Amsterdam, The Netherlands, 1989.
4. 4<sup>th</sup> Quarter 2002 Sales and Earnings Presentation, Daniel Carp, CEO, Eastman Kodak Company, Rochester, New York, USA, January 22, 2003.
5. Manufacturing Databases and Computer Integrated Systems, Dimitris N. Chorafas, CRC Press, Boca Raton, Florida, USA, 1993.
6. “CIM Development: A Strategic Management Issue”, K.B. Chuah, Integration and Management of Technology For Manufacturing, E.H. Robson, H.M. Ryan, and D. Wilcock (Editors), Peter Peregrinus, Ltd., London, England, United Kingdom, 1991.
7. “A Model Based Approach to Enterprise Wide Information Support”, P.E. Clements, I.A. Coutts & J.M. Edwards, Information Infrastructure Systems For Manufacturing: Proceedings of the IFIP TC5/WG5.3/WG5.7 International Conference on the Design of Information Infrastructure Systems For Manufacturing, DIISM 1996, Jan Goossenaerts (Editor), Chapman & Hall, London, 1996.
8. Design and Analysis of Integrated Manufacturing Systems, W. Dale Compton (Editor), National Academy Press, Washington, DC, USA, 1988.
9. “Industrial Information Resource Management”, Richard Crowder & Wendy Hall, IT and Manufacturing Partnerships: Delivering the Promise – Proceedings of the Conference on Integration in Manufacturing, Galway, Ireland, October 204, 1996, J. Browne, R. Haendler Mas, and O. Hlodversson (Editors), IOS Press, Amsterdam, The Netherlands, 1997.
10. “Kodak Beats Estimate – Jan. 24, 2000”, CnnMoney.Com (<http://money.cnn.com/2000/01/24/companies/kodak>), New York, New York, USA, April 7, 2003.
11. Made In America: Regaining The Productive Edge, Michael L. Dertouzos, Richard K. Lester, and Robert M. Solow, HarperCollins Publishers, New York, New York, USA, 1989.
12. Kodak Pro DCS-14n, 14 Megapixel full-frame CMOS – September 23, 2002”, Digital Photography Review (<http://www.dpreview.com/news/0209/02092304kodakdcs14n.asp>), April 7, 2003.
13. “Kodak DCS Pro14n”, Digital Review (<http://www.digitalreview.ca/cams/KodakDCS14n.shtml>).
14. “The History of The Eastman Kodak Company”, Eastman Kodak Company (<http://www.kodak.com/US/en/corp/aboutKodak/kodakHistory/kodakHistory.shtml>), Rochester, New York, USA, April 7, 2003.
15. “Kodak Infoimaging”, Eastman Kodak Company (<http://www.kodak.com/US/en/corp/infoImaging>), Rochester, New York, USA, April 6, 2003.

16. "Kodak Professional DCS Pro14n Digital Camera", Eastman Kodak Company (<http://www.kodak.com/global/en/professional/products/cameras/dcsPro14n/dcsPro14nIndex.jhtml>), Rochester, New York, USA, April 6, 2003.
17. 2002 Annual Report, Eastman Kodak Company (<http://www.kodak.com>), Rochester, New York.
18. Product Design and Development, Karl T. Ulrich and Steven D. Eppinger, McGraw-Hill, New York, New York, USA, 2000.
19. Clockspeed: Winning Industry Control in the Age of Temporary Advantage, Charles H. Fine, Perseus Books Group, New York, New York, USA, 1998.
20. "Designing An Information System For Integrated Manufacturing Systems", Ulrich Flatau, Design And Analysis of Integrated Manufacturing Systems, Ulrich Flatau (Editor), National Academy Press, Washington, DC, 1988.
21. "Information Technologies For High-Performing Processes", Cipriano Forza, Kathrin Tuerk, Osam Sato, High Performance Manufacturing: Global Perspectives, Roger G. Schroeder & Barbara B. Flynn (Editors), John Wiley & Sons, Inc., New York, 2001.
22. Facility Layout and Location: An Analytical Approach, Richard L. Francis and John A. White, Prentice-Hall, Inc., Englewood Cliffs, New Jersey, USA, 1974.
23. "Motorola Enterprise Integration Committee", Robert Glavin, Jr., Motorola Company Report, Schaumburg, Illinois, USA, 1990.
24. The Goal: A Process of Ongoing Improvement (2<sup>nd</sup> Edition), Eliyahu M. Goldratt, North River Press, Great Barrington, Massachusetts, USA, 1992.
25. Information Infrastructure Systems for Manufacturing: Proceedings of the IFIP TC5/WG5.3/WG5.7 International Conference on the Design of Information Infrastructure Systems for Manufacturing, DIISM '96, Eindhoven, The Netherlands, September 15-18, 1996, Jan Goossenaerts, Fumihiko Kimura, and Hans Wortmann (Editors), Chapman & Hall, London, England, United Kingdom, 1997.
26. "A Framework For Connecting Work and Information Infrastructure", J. Goossenaerts, Information Infrastructure Systems For Manufacturing: Proceedings of the IFIP TC5/WG5.3/WG5.7 International Conference on the Design of Information Infrastructure Systems For Manufacturing, DIISM 1996, Jan Goossenaerts (Editor), Chapman & Hall, London, 1996.
27. "The Mechanization of Design and Manufacturing," Thomas G. Gunn, Scientific American, 09/1982.
28. The Agenda: What Every Business Must Do To Dominate The Decade, Michael Hammer, Crown Business, New York, New York, USA, 2001.
29. The Reengineering Revolution: A Handbook, Michael Hammer and Steven A. Stanton, HarperCollins Publishers, Inc., New York, New York, USA, 1995.
30. Reengineering The Corporation: A Manifesto For Business Revolution, Michael Hammer and James Champy, HarperCollins Publishers, Inc., New York, New York, USA, 1994.
31. "How Krispy Kremes Work", Tom Harris, <http://money.howstuffworks.com/krispy-kreme.htm>, 2003.
32. Concurrent Engineering: Shortening Lead Times, Raising Quality, and Lowering Costs, John R. Hartley, Productivity Press, Cambridge, Massachusetts, USA, 1992.
33. "Knowledge based reactive management of manufacturing cells", B. Kadar, S. Markos, & L. Monostori, IT and Manufacturing Partnerships: Delivering the Promise – Proceedings of the

- Conference on Integration in Manufacturing, Galway, Ireland, October 204, 1996, J. Browne, R. Haendler Mas, and O. Hlodversson (Editors), IOS Press, Amsterdam, The Netherlands, 1997.
34. "The Launch of the Eastman Kodak DCS Pro 14n", Photokina 2002 Media Literature, Jay Kelbley, Kodak Professional, Eastman Kodak Company, October 2002.
  35. "Kodak's Developing Situation: The Dow's hottest stock in 2002 still faces a hazy digital future", Adam Lashinsky, FORTUNE, January 7, 2003.
  36. Applications of Computers to Engineering Design, Manufacturing and Management: Proceedings of the IFIP TC 5 Conference on CAD/CAM Technology Transfer: Applications of Computers to Engineering Design, Manufacturing and Management, Mexico City, Mexico August 22-26, 1998, Gerardo L. Lastra, José L. Encarnação, and Aristides A. G. Requicha (Editors), Elsevier Science Publishers, B.V., Amsterdam, The Netherlands, 1989.
  37. "Kodak Professional introduces the first 13.89 Megapixel SLR DCS PRO 14n – September 2002", Let's Go Digital ([http://www.letsgodigital.nl/webpages/events/PHOTOKINA-2002/news/kodak/Pro14n\\_uk.html](http://www.letsgodigital.nl/webpages/events/PHOTOKINA-2002/news/kodak/Pro14n_uk.html)), April 7, 2003.
  38. "Simplification Before Automation", Hal Mather, Integration and Management of Technology For Manufacturing, E.H. Robson, H.M. Ryan, and D. Wilcock (Editors), Peter Peregrinus, Ltd., London, England, United Kingdom, 1991.
  39. Photo Industry 2003: Review and Forecast, Yukihiro Matsumoto, Dimitrios Delis, Brian Longheier, and Gary Pageau , Photo Marketing Association International, Jackson, Michigan, USA, 2003.
  40. Industrial Engineering Handbook, 2<sup>nd</sup> Edition. H.B. Maynard, McGraw Hill Book Company, Inc., New York, New York, USA, 1963.
  41. "Perspectives on Manufacturing Engineering Software Integration", C.R. McLean, Information Infrastructure Systems For Manufacturing: Proceedings of the IFIP TC5/WG5.3/WG5.7 International Conference on the Design of Information Infrastructure Systems For Manufacturing, DIISM 1996, Jan Goossenaerts (Editor), Chapman & Hall, London, 1996.
  42. Systematic Planning Of Industrial Activities (SPIF) – Volume I, Richard Muther and Lee Hales, Management & Industrial Research Publications, Kansas City, Missouri, USA, 1979.
  43. Production And Operations Analysis (4<sup>th</sup> Edition), Steven Nahmias, McGraw-Hill/Irwin, New York, New York, USA, 2001.
  44. Concurrent Design of Products and Processes, James L. Nevins & Daniel Whitney, McGraw-Hill, New York, New York, USA, 1989.
  45. "UK Manufacturing: The Challenge Of Transformation", C.C. New, Integration and Management of Technology For Manufacturing, E.H. Robson, H.M. Ryan, and D. Wilcock (Editors), Peter Peregrinus, Ltd., London, England, United Kingdom, 1991.
  46. The Design of Everyday Things, Donald A. Norman, Bantam Doubleday Dell Publishing Group, Inc., New York, New York, USA, 1988.
  47. Toyota Production System: Beyond Large Scale Production, Taiichi Ohno, Productivity Press, Portland Oregon, USA, 1988.
  48. "How To Design The Best Layout For Your Factory", Queensland Manufacturing Institute Ltd. Newsletter, September 2001, <http://www.qmi.asn.au>.

49. "A Knowledge-based approach to modeling manufacturing costs at the design phase of a product's life-cycle", S. Rehman & Prof. A. J. Morris, IT and Manufacturing Partnerships: Delivering the Promise – Proceedings of the Conference on Integration in Manufacturing, Galway, Ireland, October 204, 1996, J. Browne, R. Haendler Mas, and O. Hlodversson (Editors), IOS Press, Amsterdam, The Netherlands, 1997.
50. Integration and Management of Technology For Manufacturing, E.H. Robson, H.M. Ryan, and D. Wilcock (Editors), Peter Peregrinus, Ltd., London, England, United Kingdom, 1991.
51. Interfaces In Industrial Systems For Production and Engineering: Proceedings of the IFIP TC5/WG5.10 Working Conference on Interfaces in Industrial Systems for Production and Engineering, Darmstadt, Germany, March 15-17, 1993, J. Rix and E.G. Schlechtendahl (Editors), Elsevier Science Publishers, B.V., Amsterdam, The Netherlands, 1993.
52. Manufacturing Information Systems, Luca G. Sartori, Addison-Wesley Publishing Company, Wokingham, England, United Kingdom, 1988.
53. "Distributed Conferencing Tools for Product Design", Klara Schroeder and Holger Kress, Interfaces In Industrial Systems For Production and Engineering: Proceedings of the IFIP TC5/WG5.10 Working Conference on Interfaces in Industrial Systems for Production and Engineering, Darmstadt, Germany, March 15-17, 1993, J. Rix and E.G. Schlechtendahl (Editors), Elsevier Science Publishers, B.V., Amsterdam, The Netherlands, 1993.
54. "Lean Manufacturing Glossary", SearchManufacturing.com (<http://www.searchmanufacturing.com/Manufacturing/Lean/glossary.htm>), Ruth Ellen Carey Communications, White Lake, Michigan, USA, April 7, 2003.
55. "Concept of Layout & Systems - Production Preparation Process (3P)", Shingijutsu Co., Ltd. (<http://www.shingijutsu.co.jp/E.HTM/vol03.htm/cont03.htm>), Gifu, Japan, April 6, 2003.
56. "Interfacing Technology for Manufacturing Industry: From Islands of Automation to Continents of Standardisation and beyond", Nigel Shaw, Interfaces In Industrial Systems For Production and Engineering: Proceedings of the IFIP TC5/WG5.10 Working Conference on Interfaces in Industrial Systems for Production and Engineering, Darmstadt, Germany, March 15-17, 1993, J. Rix and E.G. Schlechtendahl (Editors), Elsevier Science Publishers, B.V., Amsterdam, The Netherlands, 1993.
57. Integrated Process Design and Development, Dan L. Shunk, Business One Irwin, Homewood, Illinois, USA 1992.
58. Lean Thinking: Banish Waster and Create Wealth In Your Corporation, James P. Womack and Daniel T. Jones, Simon & Schuster Publishers, New York, New York, USA, 1996.
59. The Machine That Changed the World: The Story of Lean Production, James P. Womack, Daniel Jones, Daniel Roos, HarperCollins Publishers, New York, New York, USA, 1991.
60. "Implementing An IT Strategy In A Manufacturing Company", H.S. Woodgate, Integration And Management Of Technology For Manufacturing, Edited by E.H. Robson, H.M. Ryan & D. Wilcock, Peter Peregrinus Ltd., London, UK, 1991.
61. "Changes in the Industrial Environment and CALS", L. Zuijdgheest, Information Infrastructure Systems For Manufacturing: Proceedings of the IFIP TC5/WG5.3/WG5.7 International Conference on the Design of Information Infrastructure Systems For Manufacturing, DIISM 1996, Jan Goossenaerts (Editor), Chapman & Hall, London, 1996.



## Appendices

---



## **Appendix A: Eastman Kodak Company Overview**

Eastman Kodak Company, headquartered in Rochester, New York and founded in 1888, is one of America's oldest and most admired corporations. The company's founder, George Eastman leveraged his founding principles of mass production at low cost, international distribution, extensive advertising, and a focus on the customer to bring the "magic" of photography to the masses.

Operating with the slogan 'you press the button, we do the rest', George Eastman brought the first simple cameras to the market. The public eagerly adopted the new technology, and "snapshot" photography soon became a widely popular activity.

In its early years, the Eastman Kodak Company worked to develop its products and processes to enable easier and cheaper manufacturing, as well as improved film and image quality. After manufacturing the 100,000<sup>th</sup> camera in 1896, Eastman sought to make his product even more accessible, and launched the next version of his camera, which would sell for \$1.<sup>149</sup> From this point on, consumer photography became fixed in the public's hearts. Family events, news stories, treasured everyday occurrences and other precious memories could now be captured, shared and preserved for future generations.

These early cameras, known affectionately as "Brownies" greatly simplified what had been a complicated and cumbersome process. The cameras would be sold pre-loaded with film. After use, consumers would return the entire camera back to Rochester, where the Eastman Kodak Company would develop the film and return processed images to the customer. This design and operating structure made cameras easy to use and made photography accessible to nearly everyone. After selling 150,000 cameras in the first year of production, the Brownie camera would evolve through 125 different models, and would remain in production for over 70 years.

In addition to consumer cameras, the Eastman Kodak Company also began developing products for commercial applications, such as X-ray and motion picture film. Technology rapidly moved from the research centers to the marketplace. The products, processes, and materials developed by the Eastman Kodak Company have grown to form the core foundation of the world's photographic industry.

Today, Eastman Kodak is the photographic industry's leader. The Eastman Kodak Company has a strong global presence, with bases in over 150 countries and with over 70,000 people employed worldwide. Even in last year's "down economy", the Eastman Kodak Company stood out as not only an

---

<sup>149</sup> "The History of The Eastman Kodak Company", Eastman Kodak Company (<http://www.kodak.com/US/en/corp/aboutKodak/kodakHistory/kodakHistory.shtml>), Rochester, New York, USA, April 7, 2003.

industry leader, but a worldwide financial leader as well. Kodak ended 2002 as the Dow's top performer, with a total return of twenty-five percent, fourteen percent ahead of the Dow's second-best performer (Procter & Gamble). This is truly remarkable in a year when the average return was a loss of fifteen percent.<sup>150</sup> This performance, although largely attributable to aggressive and effective cost control activities, clearly demonstrates that Eastman Kodak's strategy and organization support its core mission, and that the Company is positioned well for the future.

The Eastman Kodak Company focuses on "developing, manufacturing and marketing traditional and digital imaging products, services and solutions for consumers, professionals, healthcare providers, the entertainment industry and other commercial customers." Its 2001 revenues came from three major segments, photography, health imaging, and commercial imaging.

The Photography segment manufactures and sells photographic film and paper products to consumer and professional markets, photographic chemicals, traditional and digital cameras, and photographic processing equipment. This segment also manages the more recent additions of digitization and online services, such as Ofoto<sup>®</sup>.

The Health Imaging segment focuses on the sale of imaging products for the health sector. The diverse product lines span analog film, equipment, photographic chemicals and specialty products for the mammography, oncology and dental fields. In addition, this group produces digital products such as laser imagers, media, and computed and direct radiography equipment.

The Commercial Imaging segment markets microfilm equipment and media, printers, scanners sold to commercial and government customers. In addition, sales from the Kodak Polychrome Graphics joint venture are included in this segment.

Grouped into the growing "Other" segment are all of the remaining products lines. As has been true throughout Kodak's history, new technologies are constantly being developed and the sales of some of these falls within this segment.

Being so heavily dependent on the success of its photographic segment, the future success of the Eastman Kodak Company has been questioned by investors. The Company's core product (consumer photographic film and paper) is facing several major challenges. First, it is facing aggressive pressure from competitors over market share. This battle for market dominance has decreased revenues for all corporations as prices for consumer film and paper have fallen. Next, the overall market for consumer film has peaked and is expected to continue to fall as digital cameras continue to penetrate the

---

<sup>150</sup> "Kodak's Developing Situation: The Dow's hottest stock in 2002 still faces a hazy digital future", Adam Lashinsky, FORTUNE, January 7, 2003.

marketplace. Finally, the advancement of technology in traditional photographic film and paper has dramatically slowed. New product features are less likely to stimulate additional demand, and therefore price advantages are expected to become the dominant factor in the market.

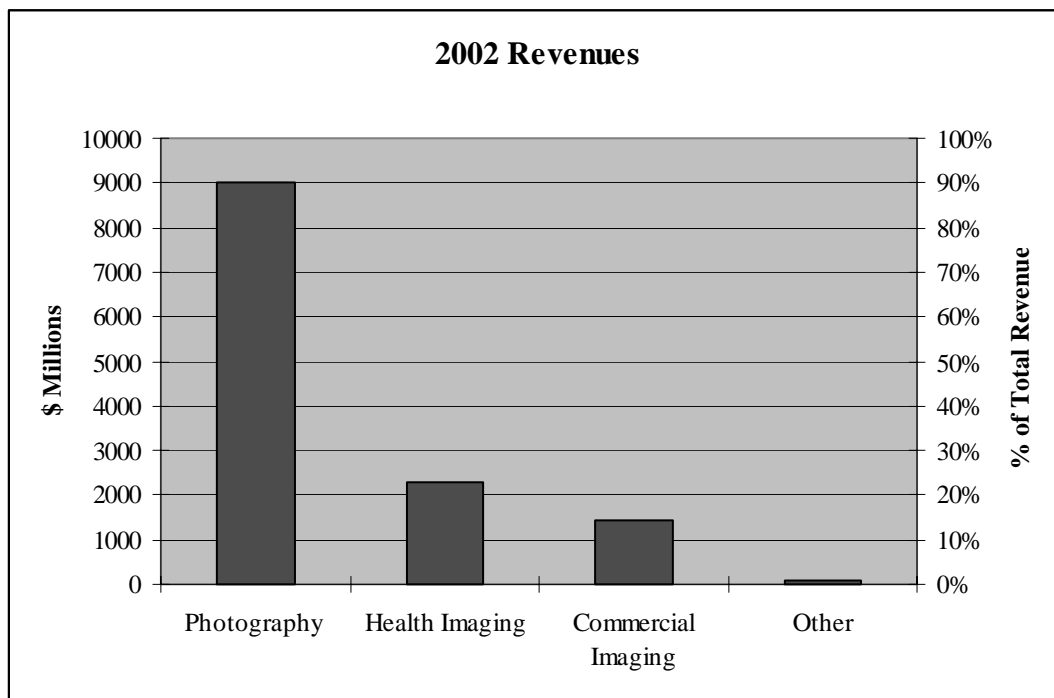

**Figure 48: 2001 Revenue by Segment<sup>151</sup>**

Aware of these challenges, Eastman Kodak is not willing to stand still, but rather is revitalizing itself and transforming to compete in the digital age. It has aggressively moved into digital photography, and currently offers a complete product line from low-end consumer models to high-performance professional models (such as the DCS Pro 14n). Eastman Kodak’s entry into digital photography may in fact be helping its other core businesses by spurring growth in the entire photography market. President and CEO Daniel Carp recently expressed that sales of digital products are helping rather than cannibalizing film sales. “We have a top position in digital cameras,” said Carp. “It’s like a treasure chest, opening up new things to do with pictures.”<sup>152</sup>

In addition to their strengthened presence in digital photography, Eastman Kodak is also attacking their challenges by leveraging what it does best (image science) and converging that with emerging information technology. This new and exciting arena, referred to as “Infoimaging”, is expected to be a

<sup>151</sup> 2002 Annual Report, Eastman Kodak Company (<http://www.kodak.com>), Rochester, New York, 2003.

<sup>152</sup> “Kodak Beats Estimate – Jan. 24, 2000”, CnnMoney.Com (<http://money.cnn.com/2000/01/24/companies/kodak>), New York, New York, USA, April 7, 2003.

\$385 billion industry.<sup>153</sup> Eastman Kodak will work to capture this market by focusing on three areas: (1) devices, (2) infrastructure, and (3) services and media. These three areas are incredibly diverse and require dedicated resources to excel in these fields. However, Eastman Kodak's leadership feels that "although no single company provides the complete range of capabilities in each Infoimaging category, Kodak has the distinction of being one of the only companies that plays in all three."<sup>154</sup> Kodak has recognized that the "Power of Information" does not only have profound effects on its manufacturing performance, but it can also make its products and services extremely attractive in the marketplace. By extracting and harnessing the information of images, Kodak offers its customers a unique and highly appealing service. Whether these images are satellite photographs of global climate patterns or CAT Scan images of internal organs, the Eastman Kodak Company leverages its products, technology, brand, market reach and a host of industry partnerships to provide products and services for all of its customers. As the digital age continues to evolve, the Eastman Kodak Company is focusing more upon digital technology and the synergistic blend of the power and convenience of electronics with the quality of traditional photochemical photography. Together, these elements combine to produce systems that bring levels of utility and fun to the taking, "making", and utilization of images.

As the Eastman Kodak Company moves forward, the company is focused on its "critical few" strategies for growth:<sup>155</sup> (1) Expand the benefits of film; (2) Driving Output in All Forms; (3) Make Digital Easier; and (4) Develop New Businesses in New Markets. These strategies will allow Kodak to continue to benefit from its profitable film product line, while transitioning customers to digital imaging.

From its early beginnings until present day, Kodak has "led the way with an abundance of new products and processes that have made photography simpler, more useful and more enjoyable". Initial core elements: simplicity and convenience, pioneering design and technology, and focus on the customer's experience remain guiding beacons for Eastman Kodak. By leveraging vast research and image science knowledge, the Eastman Kodak Company is confident that it will thrive in the new competitive arena.

---

<sup>153</sup> "Kodak Infoimaging", Eastman Kodak Company (<http://www.kodak.com/US/en/corp/infoImaging>), Rochester, New York, USA, April 6, 2003.

<sup>154</sup> Ibid.

<sup>155</sup> 4<sup>th</sup> Quarter 2002 Sales and Earnings Presentation, Daniel Carp, CEO, Eastman Kodak Company, Rochester, New York, USA, January 22, 2003.

## **Appendix B: Digital Camera Market Overview**

The nature of photography has dramatically changed over the past ten years. For decades, the industry was quite mature, using traditional photochemical materials and electro-mechanical devices to capture, record and print images. However, in these past ten years, digital photography has rapidly invaded the photographic marketplace.

Initially, digital photography's market penetration occurred in the upper customer segments. This was mainly because digital recording and processing greatly shortens the workflow for those professional photographers, as demonstrated in an earlier case. As the quality of the digital technology improved and the price of the equipment dropped, digital photography moved into all markets, including the consumer segment. Fully featured digital cameras can now be purchased for less than \$100, and some models are approaching the cost of a basic 35mm camera. The progression of product performance per dollar has decreased at a rate consistent with Moore's Law. Digital imaging has now even penetrated other consumer electronic devices, such as personal data assistant (PDAs) and cellular phones.

Many industry experts believe digital photography will continue to displace and erode the market share of photochemical materials.

“While film and traditional camera sales are projected to continue to decline, digital camera sales are expected to be strong. At the end of 2002, 21 percent of U.S. households owned a digital camera, indicating these products are beginning to reach the mainstream photo customers who take the greatest share of pictures.”<sup>156</sup>

In fact, as Figure 49 shows, in 2003 the total number of digital cameras sold is projected to eclipse the number of film cameras sold.

The benefits of digital cameras are numerous. The ease of use, the ability to check picture quality immediately after capture, the increased picture storage capacity, and the freedom from a dependence on film make digital cameras very attractive. In addition, the ability to manipulate images after capture, to easily send and archive the digital images, and to print the images at home drive many consumers to purchase digital cameras.

In addition to the change in camera purchases, the market for camera film has also been affected “Film is a mature product, and the...decline in film sales volume in 2002 is due primarily to changing consumer behavior resulting from the increased penetration of digital cameras.”<sup>157</sup> Industry experts agree

---

<sup>156</sup> *Photo Industry 2003: Review and Forecast*, Yukihiro Matsumoto, Dimitrios Delis, Brian Longheier, and Gary Pageau, Photo Marketing Association International, Jackson, Michigan, USA, February, 2003.

<sup>157</sup> *Ibid.*

that consumer film sales peaked in 2000, are expected to constantly fall in the future. For 2002, overall film sales declined by 2%. For Eastman Kodak Company, sales declined by 8%. However, Fuji Photo Film USA and private label film brands each experienced 3% growth in sales.<sup>158</sup> This underlines the earlier point that not only is Eastman Kodak Company's market for film products shrinking, but their market share of that shrinking market is also falling.

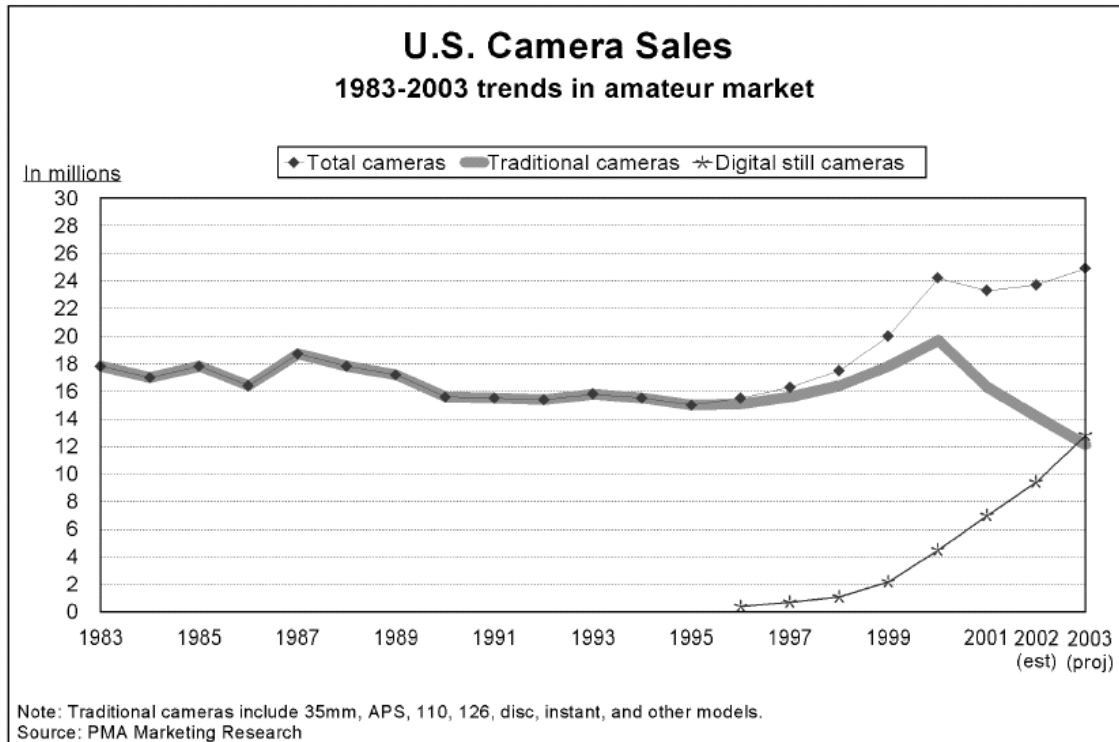

**Figure 49: U.S. Camera Sales for the Amateur Market (1983-2003)**

Because of this dramatic and rapid transformation, traditional market leaders have been forced to redefine their strategies and product offerings. Not only have traditional camera manufacturers (Nikon, Canon, etc.) moved into this segment by developing new digital cameras, but other companies (Sony, Panasonic, etc.), which possess significant power in the consumer electronics industries, have also invaded the market. The result is the largest reshuffling of industry power to occur in photography in decades. Dan Palumbo, president of Kodak Consumer Imaging, expressed that 2003 will be “the year ‘output oriented’ communication will be above ‘capture oriented’ communication. In simplest terms, we’ve been a film communicator throughout our history, through 2002. Starting in 2003, communication will be more about [digital processing], digital cameras, and [digital printing], than about film. We are

<sup>158</sup> Ibid.



still totally dedicated to film, but now our communication will be about output with a massive digital perfection bent. That will be the first time in history.”<sup>159</sup>

Faced with the changing makeup of photographic products, the Eastman Kodak Company has developed a complete line of digital products, including digital cameras, digital multi-media cards, digital scanners, and digital printers. The realignment of this industry giant shows just how much the photography has changed. As sensor technology continues to evolve, and as the digital imaging infrastructure (i.e. home printing) continues to improve, digital photography will no doubt become the dominant method to capture and share images.

---

<sup>159</sup> Ibid.



## Appendix C: DCS Pro 14n Digital Camera Overview

On September 23, 2002, the Eastman Kodak Company took the photographic industry by storm. With the unveiling of the DCS Pro 14n camera, Eastman Kodak redefined the standard for high performance digital photography. The camera makes use of a revolutionary type of digital imaging sensor, based on CMOS semiconductor technology. “Heeding photographers' calls to simplify the transition to digital photography, the DCS Pro 14n includes features for new and more advanced digital shooters.”<sup>160</sup> The DCS Pro 14n excels at “saving photographers time and improving workflow, hallmarks of Kodak Professional's efforts to make digital easier for customers.”<sup>161</sup>



**Figure 50: The Eastman Kodak DCS Pro 14n Digital Camera**<sup>162</sup>

“The digital camera learning curve has been sharply reduced with the DCS Pro 14n. Novices and advanced users will be equally at home with the camera's user-friendly functionality...As Kodak continues to lead the industry in digital capture, [Kodak designs] cameras to grow with the photographer. Whether it's a beginner or experienced digital photographer ready to move up to a pro series camera, the DCS Pro 14n will help users explore new territory and upgrade along the way.”<sup>163</sup>

“The easy-to-use DCS Pro 14n is Kodak's sixth-generation professional digital camera and is primarily designed for professional portrait, wedding, event and commercial photographers, but will likely be popular with advanced amateurs as well. Built on a Nikon lens mount, it adds speed, as well as quality, to the photographers' workflow through

---

<sup>160</sup> “Kodak Professional introduces the first 13.89 Megapixel SLR DCS PRO 14n – September 2002”, Let's Go Digital ([http://www.letsgodigital.nl/webpages/events/PHOTOKINA-2002/news/kodak/Pro14n\\_uk.html](http://www.letsgodigital.nl/webpages/events/PHOTOKINA-2002/news/kodak/Pro14n_uk.html)), April 7, 2003.

<sup>161</sup> Kodak Pro DCS-14n, 14 Megapixel full-frame CMOS – September 23, 2002”, Digital Photography Review (<http://www.dpreview.com/news/0209/02092304kodakdcs14n.asp>), April 7, 2003.

<sup>162</sup> Image provided courtesy of Eastman Kodak Company, ©Eastman Kodak Company, 2003

<sup>163</sup> Jay Kelbley, DCS Product Manager, Kodak Professional, Photokina 2002 Press Interview

FireWire connectivity at a 12 MB per second transfer rate, nearly four times faster than previous Kodak Professional cameras.”<sup>164</sup>

“This is the camera that portrait, wedding and event photographers have been waiting for...In addition to its highly competitive price point and phenomenal 13.89 million total pixels, the DCS Pro 14n is loaded with features and...its overall image path enhancements make it the most upgradeable camera on the market.”<sup>165</sup>

The DCS Pro 14n brings a number of novel technologies to the forefront of the market. The aforementioned CMOS-based sensor provides a number of benefits. First, it allows the camera to capture images at 13.89 Megapixels, more than twice that of any digital SLR camera on the market. This incredible resolution level enables users to make prints with finer detail than photochemical film at sizes greater than 20”x 30”. In addition, the imager can “incorporate light-sensing technology that allows for charge conversion right inside the pixel, therefore dramatically reducing support electronics and power consumption.”<sup>166</sup>

These technical aspects result in incredible image quality and unbelievable performance. Figure 51 through Figure 53 shows some of the incredible resolution that can be captured by the DCS Pro 14n.

An additional revolutionary feature of this product is the retail price of \$5000. Current high performance digital cameras have retail prices ranging from \$5000 to \$10,000, yet only produce images between 5 and 6 Megapixels. Therefore, when considering image resolution, the DCS Pro 14n is offering more than twice the performance, yet is priced extremely attractively. While the DCS Pro 14n is expected to draw sales away from Eastman Kodak’s current professional cameras, program managers are confident that the new sales generated through capturing “high-end amateurs”, as well as new professional customers, will more than offset the loss.

“With its aggressive price-point and high resolution...the Kodak DCS Pro 14n will receive serious attention, especially for users that already have investments in Nikon optics or for those that are looking to enter the market for the first time. If Canon does not adjust their pricing, it is

---

<sup>164</sup> Kodak Pro DCS-14n, 14 Megapixel full-frame CMOS – September 23, 2002”, Digital Photography Review (<http://www.dpreview.com/news/0209/02092304kodakdcs14n.asp>), April 7, 2003.

<sup>165</sup> “The Launch of the Eastman Kodak DCS Pro 14n”, *Photokina 2002 Media Literature*, Jay Kelbley, Kodak Professional, Eastman Kodak Company, October 2002.

<sup>166</sup> “Kodak Professional DCS Pro14n Digital Camera”, Eastman Kodak Company (<http://www.kodak.com/global/en/professional/products/cameras/dcsPro14n/dcsPro14nIndex.jhtml>), Rochester, New York, USA, April 6, 2003.

also quite possible that some existing Canon users might 'abandon ship' and gravitate towards Nikon optics and the DCS Pro 14n."<sup>167</sup>

The DCS Pro 14n will be produced internally at Eastman Kodak Company, produced in the High Performance Imaging Systems Manufacturing Division, in Rochester, New York. This group, closely aligned with the Kodak Professional engineering division has produced all prior models of Eastman Kodak's professional digital cameras.

Based on early sales recorded since the product was announced, the market has overwhelmingly embraced the DCS Pro 14n. This high number of already received orders, coupled with the positive media reception, signals that this product is expected to become highly successful for the Eastman Kodak.



**Figure 51: A Sample Portrait Shot<sup>168</sup>**



**Figure 52: Incredible Detail**

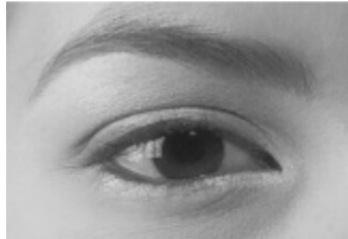

**Figure 53: More Detail!**



**Figure 54: Even More Detail!**

---

<sup>167</sup> "Kodak DCS Pro14n – September 2002", Digital Review (<http://www.digitalreview.ca/cams/KodakDCS14n.shtml>), April 7, 2003.

<sup>168</sup> Image provided courtesy of Eastman Kodak Company, ©Eastman Kodak Company, 2003.



## **Appendix D: How Focusing on Information Has Transformed the Workflow of Professional Photography**

The transformation of the workflow in professional photography, as a result of the introduction of the digital imaging technology, provides an interesting illustration of the incredible benefits that can be obtained by considering the use and flow of information.

The professional photography segment includes photojournalists, wedding, sports, catalogue, and studio portrait photographers. These customers use their cameras to earn their livelihood, so this market segment quickly embraces any improvement in photographic technology.

Prior to the introduction of the digital systems, the traditional workflow resembled that shown in Figure 55. In this workflow, the photographer captures images with a traditional camera. While the performance of many professional cameras is extremely sophisticated, there are many deficiencies in the overall workflow. Each of these deficiencies add time to the overall process, and reduces the time that photographer can spend taking pictures.

First, several times during the photo shoot, the photographer has to change rolls of film, each time potentially missing some critical action. Next, upon completion of the photo shoot, the photographer has to develop the rolls of film, using specialized darkrooms and toxic chemicals. After developing the film, the photographer has to review the images, and select the acceptable shots. Next, the photographer would then produce proofs of the shots, and review these with their client or editor. For those shots that are accepted, the photographer then scans the film negative of these shots and produces final prints of the images. The images are then sent for digital printing and archiving. Lastly, the photographer stores the film negatives using special environments, where dust, light, temperature, and humidity levels are tightly controlled.

Throughout this process, there is a chance that acceptable photographs are not produced. If this occurs, the photographer has to arrange another shooting session. However, if the subject was a sporting event or a wedding, it is difficult, or impossible, to arrange another session.

Therefore, the major disadvantages with the traditional workflow are significant. Due to the time and labor required, and the strong potential of missing action or not producing photos that the client desires, several sources of waste exist and make this process labor-intensive and very inefficient.

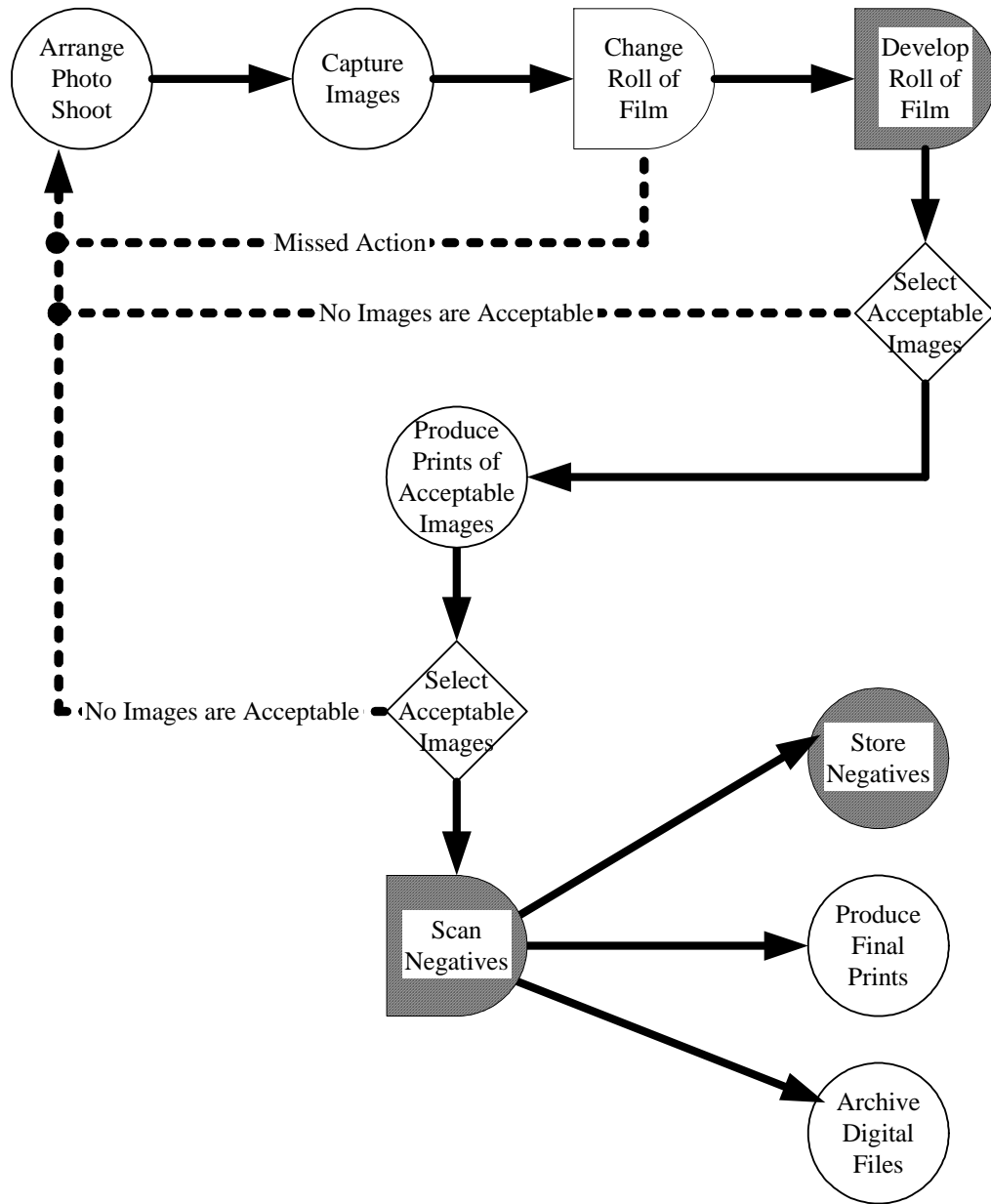

**Figure 55: The Traditional Workflow of Professional Photography**

Rather than focusing only on the performance of the camera equipment, the Eastman Kodak Company has developed products that simplify the entire workflow for the professional photographer. Using their digital systems, waste has been minimized, and the workflow has been greatly improved, as represented by Figure 50.



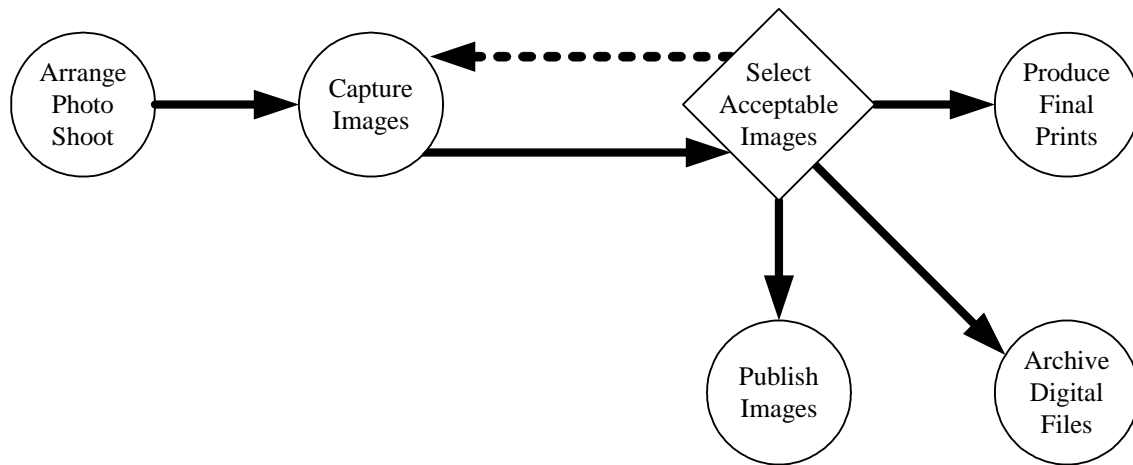

**Figure 56: The Improved Workflow of Professional Photography**

The photographer now captures the images with a digital camera. The images are automatically and quickly downloaded from the camera to a computer. Thus, the photographer no longer has to pause to change rolls of film, and can continue to shoot the action. The photographer no longer has to develop the rolls of film, because the images are being stored as digital files. Thus, the development time, and the specialized facilities are no longer needed. In addition, the images are ready for review immediately after capture. The photographer and the client can review the images within seconds, and decide whether the image is acceptable. The photographer can then produce prints of the acceptable shots, and can send the digital image to be published and archived. For the client, this improved flow brings the benefits of faster overall service, the guarantee of acceptable images, and reception of immediate gratification. For the photographer, this improved flow brings the benefits of less overall labor time spent per client, reduced investment expenses (rolls of film, film developing facilities, and archiving equipment), and a more satisfied client. Also, for both parties, there is a lower chance of missing a photo opportunity or of having to reschedule shooting sessions.

When designing the workflow for the professional photography customer, Eastman Kodak mapped out the entire workflow of their clients, and ensured that each step in the flow integrated seamlessly with the other steps. The sources, sinks, uses, and requirements for each informational element were carefully considered and added to the flow architecture. Informational constraints were eliminated. Informational operations (such as the review by the client) were moved upstream. And non-essential information (such as storage of the film negative) was completely eliminated. The result was a tightly integrated system that meets the needs of its customers, without added unneeded complexity.