

Sensing Bending in a Compliant Biomimetic Fish

by

Adam S. Kaczmarek

Submitted to the Department of Mechanical Engineering
in partial fulfillment of the requirements for the degree of

Bachelor of Science in Mechanical Engineering

at the

MASSACHUSETTS INSTITUTE OF TECHNOLOGY

June 2006

© Massachusetts Institute of Technology 2006. All rights reserved.

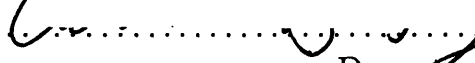
Author .. 
Department of Mechanical Engineering
May 12, 2006

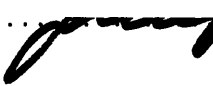
Certified by .. 
Kamal Youcef-Toumi
Professor of Mechanical Engineering
Thesis Supervisor

Accepted by .. 
John H. Lienhard V
Professor of Mechanical Engineering

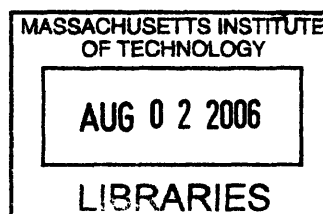

ARCHIVES

Sensing Bending in a Compliant Biomimetic Fish

by

Adam S. Kaczmarek

Submitted to the Department of Mechanical Engineering
on May 12, 2006, in partial fulfillment of the
requirements for the degree of
Bachelor of Science in Mechanical Engineering

Abstract

This thesis examines the problem of sensing motion in a compliant biomimetic device. Specifically, it will examine the motion of a tail in a biomimetic fish. To date, the fish has been an open-loop system, the motion of the tail only controlled by the input to a servo motor. By sensing the motion of the tail, a closed loop system can be implemented to control the motion. In order to determine the best sensor to use, a number of options were examined. We decided to use foil bend sensors. The silicone used in the prototype was too compliant and therefore the sensors did not bend at a magnitude great enough to provide sufficient information about the bending of the tail. Upon further development and use of the sensors in stiffer silicones, they could be used in a closed loop system.

Thesis Supervisor: Kamal Youcef-Toumi
Title: Professor of Mechanical Engineering

Contents

- 1 Introduction 7**
 - 1.1 Biomimetic Devices 7
 - 1.2 Previous Work 7
 - 1.3 Motivation 8
 - 1.4 Applications 8
 - 1.5 Problem Statement 9
 - 1.6 Thesis Outline 9

- 2 Sensing Specifications 10**
 - 2.1 Introduction 10
 - 2.2 Shape of the Biomimetic Fish 10
 - 2.3 Expected Motion of the Device 11
 - 2.4 Other Important Design Constraints 11
 - 2.5 Summary 12

- 3 Sensing Alternatives 13**
 - 3.1 Introduction 13
 - 3.2 Accelerometers 13
 - 3.3 Foil Strain Gages 14
 - 3.4 Bend Sensors 15
 - 3.5 Piezo Sensors 15
 - 3.6 Summary and Choice of Sensor 16

4	Proposed Approach	18
4.1	Introduction	18
4.2	Wiring Bend Sensor	18
4.3	Mixing and Pouring Silicone	19
4.4	Orienting Bend Sensors	19
4.5	Testing the Fish	20
4.6	Summary	21
5	Experiments	22
5.1	Introduction	22
5.2	Calibrating Sensors	22
5.3	Elongated Tadpole	24
6	Conclusion and Recommendations	31
6.1	Conclusion	31
6.2	Recommendations	32
A	Vendors and Suppliers Used	33
A.1	Sensors	33
A.2	Silicone	33
A.3	Wax	33

Chapter 1

Introduction

1.1 Biomimetic Devices

Biomimetic devices are designed to mimic the performance of biological life in nature. Devices that can accurately emulate biology are very useful in a variety of applications. There is a great deal of research going on that aims at improving such devices. Specifically, this thesis will focus on improving the performance of a fish-like biomimetic device. This autonomous fish has been in development for a number of years. Currently, the fish operates with open-loop control of a servo motor. Since there are no on-board sensors, the computer has no way of knowing the effectiveness of the motion that the servo motor imparts. Due to this, no closed-loop control system can be implemented to make the motion of the tail match actual biology more closely than a strictly open-loop system.

1.2 Previous Work

Much research has been put into determining the actual equations of motion for many biological devices in order to mimic them. Many groups have applied this research and made biomimetic devices, including multiple jointed fish[2]. However, there seems to be no standard or reliable way to sense the motion of the tail without the use of an external camera or similar device.

The fish used in this work to experiment with sensing is based off of one that was previously designed by Alvarado[3]. It consists of a single servo motor encased in silicone, which creates sinusoidal motion that propels the fish forward. The fish will be modified in order to make it neutrally buoyant, so that the fish will stay submerged in the testing tank during tests instead of rising to the top, as well as longer, so that the sinusoidal motion of the tail will be exaggerated.

1.3 Motivation

Previous work with fish-like biomimetic devices has led to limited performance. Some of this may have to do with the materials that are chosen to be used, or the design of the fish, but a large part of it is the uncertainty of the actual movement of the tail. By using sensors, it can be determined if the correct motion is being attained from the servo motor. If the tail is following an undesired pattern, these sensors can also be used in a feedback control system to yield the desired results.

Similar feedback control exists for other robotic devices, in order to make sure that components of the device are behaving as prescribed. Signal processing for these applications is already a well developed research area, but accurately detecting the motion of similar compliant silicone bodies is not, so this thesis will focus on the latter, rather than the former.

1.4 Applications

There are many types of biomimetic devices in which accurate motion sensing could increase efficiency and accuracy. Silicone or similar materials are frequently used to mimic skin and tissue of living things, due to their material properties. As devices become more life-like, ways to accurately measure motion of these artificial tissues becomes more important, seeing as most of the structure can be made of them.

Unlike stiff materials, like metals or hard plastics, sensors can not be simply glued to silicone. Developing a repeatable, accurate method for sensing the deflection in

silicone would be extremely valuable. This thesis examines a number of options available for this application and investigates and tests the most viable one. It is important for these sensors to be accurate, small (so as not to affect the motion of the device), and easy to implement, both mechanically and electrically in the circuit.

1.5 Problem Statement

In existing biomimetic fish, the motion of the tail is an open loop system. To maximize the performance of the device, a closed loop control approach should be implemented. This can only be done properly with accurate sensing of the motion of the tail. Existing methods of sensing are not easily adapted to highly flexible bodies, such as the compliant fish tail. By finding an accurate and easy to implement method, this thesis should make this possible for future researchers to do. The methods by which the motion is determined will be clearly outlined and repeatable.

1.6 Thesis Outline

Chapter 2 of the thesis will document the ideal motion of the fish that will be made, so that the range of sensing that needs to be done can be determined. Chapter 3 will investigate a number of options for sensing motion that already exist, and one option will be chosen to be implemented. The proposed approach to implementing the sensors and the experiments will be discussed in chapters 4 and 5. Finally, chapter 6 contains conclusions and recommendations.

Chapter 2

Sensing Specifications

2.1 Introduction

In order to properly choose the correct sensors, sensor distribution, and sampling method, the expected behavior of the biomimetic device needs to be described. This chapter will look at the choice of shape for the device, the projected motion of the tail, and other important design parameters.

2.2 Shape of the Biomimetic Fish

Eventually, sensing will be done in a biomimetic fish that is proportional to an existing biological fish. For this thesis, the interesting part of the fish is the movement of the tail and not the functionality of the fish itself. Therefore, we wanted to design a fish with a long tail in order to exaggerate the motion of the tail (See figure 2-1). The tail here is six inches from the actuation plate to the tip. From this platform, sensors can be scaled down to the more accurate shorter tailed fish.

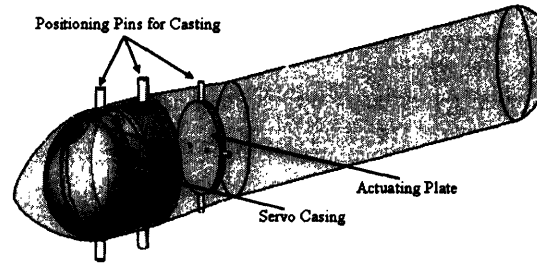

Figure 2-1: 3-D CAD model of fish with extended tail.

2.3 Expected Motion of the Device

The motion of a fish can be described by the following equation [3]:

$$h(x, t) = (c_0 + c_1x + c_2x^2) * \sin(kx + \omega t) \quad (2.1)$$



Figure 2-2: Diagram for equation 2.1.

Where the constants c_0 , c_1 , c_2 , and k are based on the material and shape of the device. Fish swim with their tails oscillating at frequencies, ω , anywhere from 0.5 Hz to 12 Hz, based on the size of the fish. For this prototype, in order to get more measurable motion, we will use a range from 0.5 Hz to 3 Hz. The sensors need to be able to sense motion that is as fast as this.

2.4 Other Important Design Constraints

Many factors need to be considered when deciding how to measure the motion of the tail. For this thesis, we will be interested in the motion of a single point along

the tail, but one could potentially be interested in characterizing the shape of the entire tail at any given time. When measuring for the single point or for the full characterization, each sensor needs to be sensing a very small Δx along the length of the tail in order to be as accurate as possible. The positioning of the sensors will be discussed in chapter 4.

Next, the physical properties of the sensor and the electronics it may require are important. The biomimetic device is made of silicone, so first, the sensor must not react and affect the curing of the silicone. Next, the physical footprint and weight of the device need to be minimal, since a large payload would likely hinder the performance.

The reason that silicone is used to make these devices, especially in the tails, is to provide the viscoelastic behavior to accurately mimic biological motions [3]. Therefore, it is desirable for the sensor to have little or no effect on the material properties of the tail. This is true if the sensors are placed in discrete locations along the tail, instead of along the whole tail, since it will drastically affect the location of modes of vibration.

2.5 Summary

From the information provided in this chapter, it should be straightforward for one to determine a sensing methodology for application to these biomimetic devices. A type of sensor needs to be chosen that will meet as many requirements as closely as possible.

Chapter 3

Sensing Alternatives

3.1 Introduction

There are a variety of different sensing methods and technologies available today. In regards to the biomimetic fish, each type of sensor has its own benefits and drawbacks, seeing as none was specifically designed for this particular application. The limitations on the sensors were discussed in chapter 2. In order to choose the right sensor for this application we needed to evaluate different alternatives.

3.2 Accelerometers

Accelerometers are small devices that can be used to measure acceleration. They come in a variety of sensitivities, ranges, and sizes. The benefit to using an accelerometer in this application is that by performing a double integration, the position of the sensor would be straightforward to find. By placing the right number of sensors along the length of the fish, the shape of the tail at any given time would be easy to ascertain.

One of the disadvantages of using accelerometers for this application is the drift that is sometimes associated with them. Since the sensor relies on the user knowing the original position of the sensor, any deviation from that original position causes a ripple effect of inaccuracies in the sensing. Knowing a point's absolute position is better than simply knowing where it is in relation to a starting point. Every time the

device would turn on, it would have to go through a calibration sequence, based on knowing that the tail was straight.

Another problem is that making circuits and carrying out the wiring for the double integrations and the amplifiers would be a very complicated task. As stated in chapter 2, ideally, the sensor chosen would be very easy to implement and not need re-calibration every time the fish was put into the water and turned on.

3.3 Foil Strain Gages

Foil strain gages rely on the property that when a wire is extended, its cross-sectional area decreases, which increases its resistance. This effect is of very small order, so in order to use it as a sensing strategy, the wire loops back and forth a number of times inside the gage itself, see Figure 3-1. An increase x in length of the gage, increases the length of the wire many times x , changing the resistance of the wire. This can be a difficult type of sensor to implement for a number of reasons: The sensitivity of strain

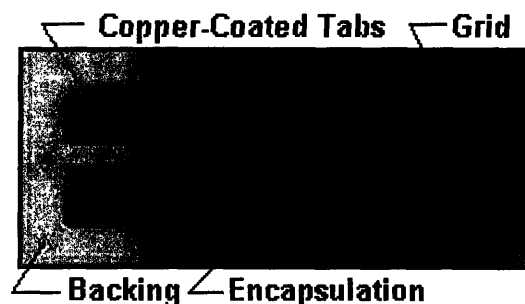

Figure 3-1: Strain Gage Diagram.

gages is very high, so a large amplifier needs to be used to make the signal visible. Such an amplifier usually has a number of batteries and has a very large weight and footprint. If the biomimetic device was much larger or was always connected externally to a computer, it would make this much less of a disadvantage. Another problem is that the sensed values drift as the temperature of the gage increases due to the current flowing through it. Chips exist that can control this, but they add

complexity to the circuitry. Lastly, strain gages are designed to be glued to materials that are much less flexible than themselves. Accurately using them in the bio-mimetic fish would require testing to re-calibrate them for use within silicone, a material that is far more compliant than the sensors themselves. It is doubtful that this would be repeatable across silicones with slightly different material properties.

3.4 Bend Sensors

Bend sensors are foil gages, which look similar to strain gages. Unlike strain gages, bend sensors have a strip of special conductive ink on them. The ink has small notches in it down the length of the sensor. As the gage bends, the gaps become larger and the resistance of the device increases from 2 kilo-ohms to about 100 kilo-ohms, based on how much the device is bent, see Figure 3-2. For the application in our biomimetic device, the resistance will likely be ranging from 2 kilo-ohms to 10 kilo-ohms, based on the radii of curvature that are expected to be seen. This change makes it very straightforward to measure bending using a voltage divider and doesn't require an amplifier or any complicated signal conditioning. One disadvantage, however, is that bend sensors are a fairly new sensing technology. The company that sells them, Flexpoint, Inc., does not offer any established gage factors, relating resistance to radius of curvature of the sensor. Also, the shortest length sensor that the company currently offers is 1" long, which can be trimmed to about 0.75". This means that the sensor is not measuring the radius of curvature at one distinct point, but along a 0.75" length.

3.5 Piezo Sensors

Piezo sensors are made of a thin film, which produce electricity when they are bent. Since these sensors only produce a voltage difference during the bending, it can be hard to capture the signal. When the sensor is not moving, even if it is bent, the voltage produced is zero. Therefore, there would need to be both intensive signal

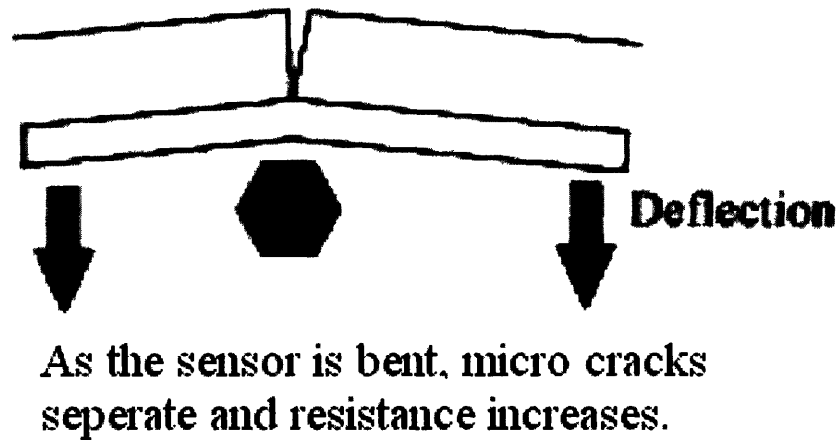

Figure 3-2: Bend sensor diagram.

conditioning and re-calibration every time the device was used. These are two things that should be avoided in such a small device of this type.

3.6 Summary and Choice of Sensor

The best sensor for use in the tail of a small biomimetic fish would be the bend sensor. Even though it can't measure the radius of curvature at a distinct point, it is likely that later bend sensors will be even shorter, becoming more and more accurate. Many of the other sensors require re-calibration every time the device is turned on, which is definitely a drawback, and most of them have a much larger weight associated with the supporting circuitry. Table 3.1 summarizes the pros and cons that were discussed of each type of sensor that was proposed.

Bend sensors give a fairly new option that is an excellent fit for this application. The electrical implementation requires no amplifier, only the gage and a resistor to create a voltage divider. Physically, they can be encased in the silicone of the tail halfway through the pour and are straightforward to align with the axis of the fish.

Sensor Type	Weight	Size	Accuracy	Calibration	Complexity	Supporting Hardware
Accelerometers	+	+	+	-	-	-
Bend Sensors	+	o	+	o	+	+
Piezo Film	+	+	+	-	-	-
Strain Gages	+	+	+	+	-	-

Table 3.1: Choice chart for sensor, + is good, o is neutral, - is bad.

Chapter 4

Proposed Approach

4.1 Introduction

This chapter details how we intend to measure bending in the biomimetic fish. A bend sensor was chosen, since it required the least amount of signal processing and re-calibration at the beginning of each run. We will cover how it was wired, calibrated, and finally implemented in the biomimetic device.

4.2 Wiring Bend Sensor

One concern with foil bend sensors is that while soldering leads onto them, the foil can reach a temperature at which it plastically deforms, changing the properties and strain constants associated with the gage. To minimize this effect, the sensor was placed under an aluminum block during the attachment of the leads. The metal block acted as a heat sink, pulling the heat away from the sensor.

A thin wire was used for the leads, to minimize the effect that the wire had in the stiffness of the tail itself. After stripping the ends, the wire was tinned with solder. The soldering iron was then placed on the pads of the bend sensor to heat them. The already tinned leads were held on the pads until they formed a bond. After attaching both leads, the resistivity was tested to make sure that there were no shorts and the behavior of the sensor was normal.

4.3 Mixing and Pouring Silicone

The silicone used consisted of a part "A" silicone and a part "B" silicone, supplied by Quantum Silicones, Inc. The mixing ratio was 1:2. One part of "A" was measured out into a clean beaker. The scale was then reset and twice as much of part "B" was added to the beaker. The two were then thoroughly mixed together. The beaker was then placed into a degassing chamber, where a vacuum was pulled on the sample of 29 mm of Mercury. The mold of the tadpole was then filled halfway, in order to allow for the placing of the sensors.

4.4 Orienting Bend Sensors

The pre-wired sensors were aligned parallel to the length of the tadpole. They were placed flat on the already cured half mold of the fish, with the wires going straight back to the head, where the tether would go up and out to the computer. Three sensors were placed an inch apart, starting an inch back from the plate that imparts the moment on the tail, see Figure ???. By sampling with time, at the minimum only one sensor would be needed to use for feedback, but to get a more full description of the motion for this thesis, we used three sensors.

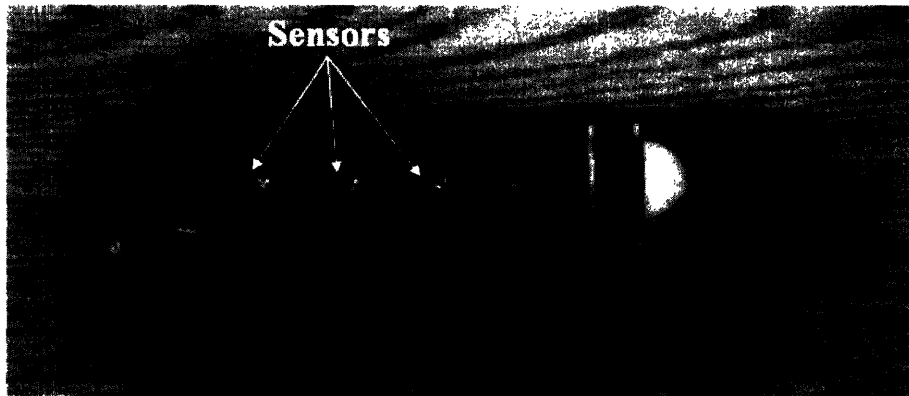

Figure 4-1: Fish in mold, complete with sensors.

After checking the alignment, a small amount of silicone was poured over the silicone to secure it to the existing cured silicone. After that cured, the second half of

the mold was poured. The silicone finished curing in 24 hours, and the strain gages were tested again to verify that they were indeed working.

4.5 Testing the Fish

In order to monitor the resistance of each of the sensors, each one was used in a voltage divider. In order to maximize the resolution of Equation 4.1, a resistor on the order of the resistance of the sensor should be used. In this application, a 10 volt source was supplied and split between each sensor and a 4.7 kilo ohm resistor. See Figure 4-2.

$$V_{measured} = \frac{R_{sensor} V_{supply}}{R_{sensor} + R} \quad (4.1)$$

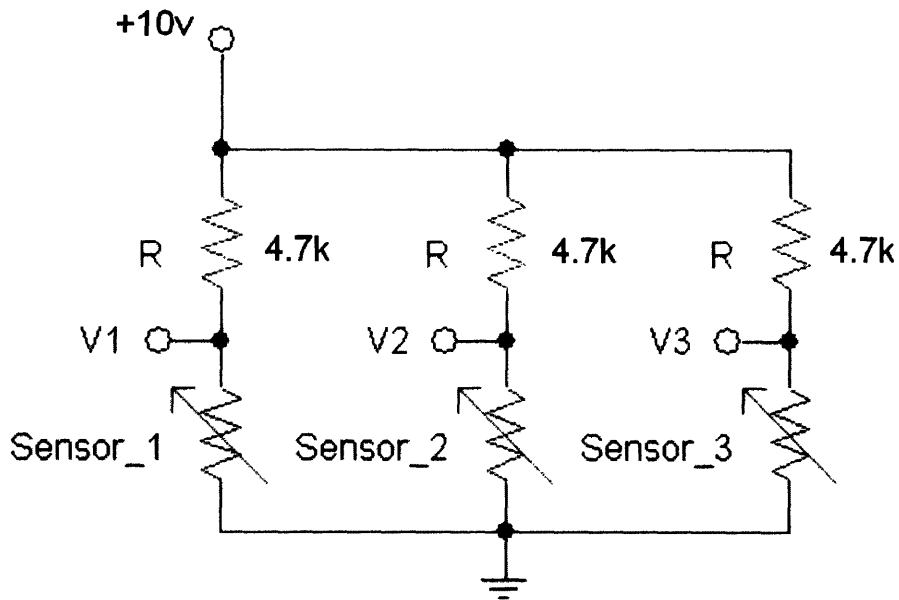

Figure 4-2: Wiring of Sensors

The fish was secured by a metal support in the water tank. By holding the fish in place, it was easy to place a camera above the tank to record the motion of the tail. A function generator was used to move the servo inside the fish at frequencies of 0.5 Hz up to 3 Hz. The camera recorded the motion at 30 frames per second. The voltages,

V1, V2, and V3, were measured on an oscilloscope along with the input signal.

4.6 Summary

Assembling the fish correctly and making sure that all the sensors function properly is a multi-step process which takes a great deal of time, due to the length of the silicone curing time. The testing of the fish a short portion of the time, only two full periods of data need to be collected in order to verify the model and that the sensors are behaving as expected.

Chapter 5

Experiments

5.1 Introduction

Since the bend sensors supplied are a new technology, they have no data sheet relating resistance level to a given radius of curvature. A calibration of the sensors is needed to make sure that the data acquired from the sensors in the fish was realistic.

The actual testing of the sensors on a biomimetic device was done on an elongated tadpole in order to exaggerate the sinusoidal motion of the tail. The data taken from the sensors was then matched to images taken from the fish tail moving.

5.2 Calibrating Sensors

The main problem with using the bend sensors is that the correlation between the resistance of the sensor and the radius of curvature is not supplied with the sensors. In order to calibrate this relationship, sensors were glued to a thin plastic sheet that could be bent to different radii of curvature. The radius of curvature was determined from the distance d and the original length ℓ in Figure 5-1, using Equation (5.1). A side view of the plate bending can be seen in Figure 5-1, and an actual picture of the set-up can be seen in Figure 5-2.

$$\sin\left(\frac{\ell}{2r}\right) = \frac{d}{2r} \quad (5.1)$$

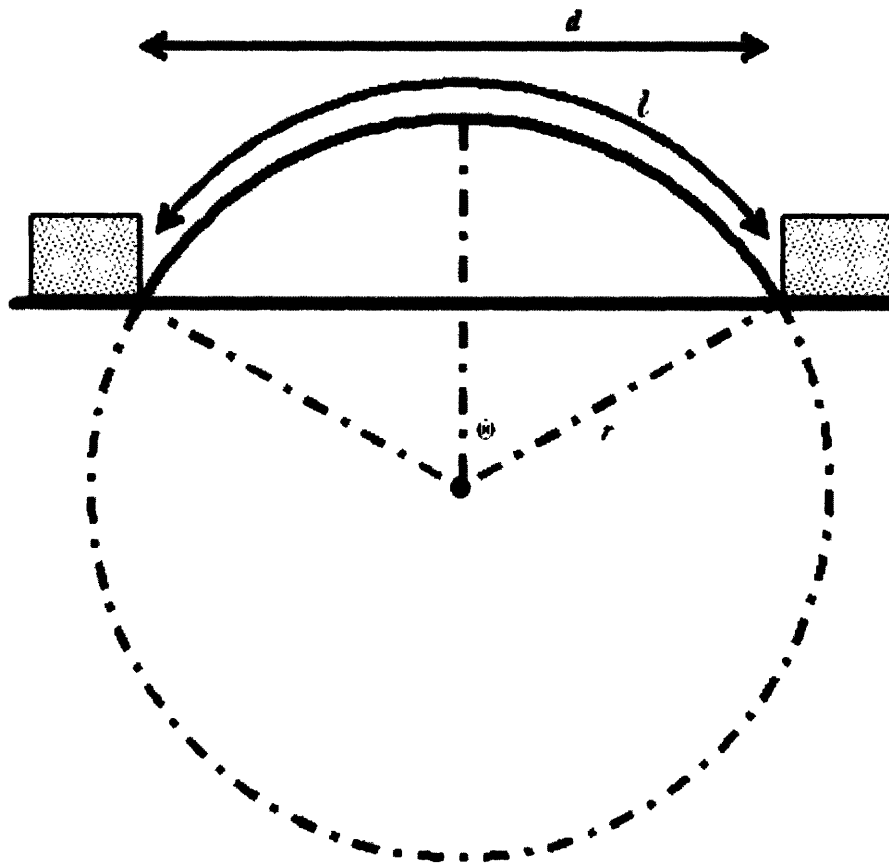

Figure 5-1: Diagram of calibration set-up.

The range of values of radii of curvature typically seen in the tadpole device are on the order of perfectly flat to 300 mm. To fully describe the gage through these values, the shape of the plastic sheet was changed from completely flat to a radius of 285 mm, iterating the distance d by 5 mm between each measurement.

The measured voltage at each radius of curvature for two sensors is shown in Table 5.1 and the accompanying Figures 5-3 and 5-4. Each sensor has a different starting base resistance. The shape of the curve is the same, but offset by the initial resistance. The best fit this data is Equation (5.2), where r is the radius of curvature in mm and R is the resistance of the sensor in Ohms.

$$\log(r) = 0.97215 \log^2(R) - 8.567 \log(R) + 21.3575 \quad (5.2)$$

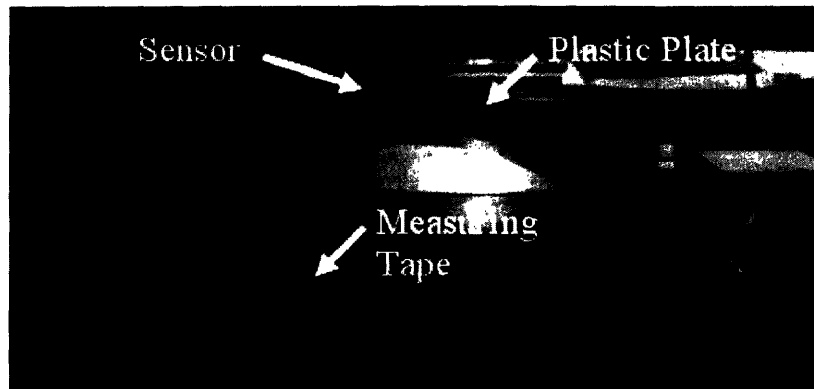

Figure 5-2: Picture of calibration set-up

5.3 Elongated Tadpole

The head of the elongated tadpole was secured to a stand so that the motion of the tail could be observed with a stationary camera (see Figure 5-5).

The behavior of the fish was recorded at 30 frames per second. We oscillated the tail from 0.5 Hz to 3 Hz, iterating every 0.5 Hz. The tail hit a natural frequency at an oscillation of about 2 Hz, so the resulting motion was very easy to observe. The sensors were hooked up to an oscilloscope and the data from them was recorded as well.

After the data was taken, the first step was to fit a waveform to the video data. For the 2 Hz sample, the wave in Equation (5.3) fit best, as you can see from Figure 5-6.

$$h(x, t) = 0.005 * \sin(2.0994 + \omega t) * \sin(0.0873 + 40x) \quad (5.3)$$

To be able to determine what the sensors should have been measuring, the radius of curvature at each sensor needed to be calculated. This was done using equation 5.4 [1]. The radius of curvature of a point on an arbitrary function f is related to both the first derivative of the function, f' , evaluated at the point, and the second derivative, f'' . A plot of the expected data can be seen in figure 5-7. The top and bottom of the graph have been cut off, since as the point on the tail becomes flat,

Radius of Curvature	Resistance of First (Ohms)	Resistance of Second (Ohms)
1500	2330	4370
970	2830	5250
791	3230	6280
684	3700	6970
611	4270	7760
557	4850	8590
515	5300	9770
481	5840	10550
453	6450	11450
429	6940	12380
409	7510	13450
391	8020	14200
375	8850	15220
361	9540	16410
348	10380	17530
337	10960	18510
326	11690	19570
317	12560	21210
308	13430	22260
300	14500	23320
292	15370	24410
285	16280	25530

Table 5.1: Data from calibration of two sensors.

the radius of curvature becomes infinite.

$$r = \frac{(1 + f'^2)^{\frac{3}{2}}}{f''} \quad (5.4)$$

The raw data from the oscilloscope for the sensor closest to the head of the fish can be seen in Figure 5-8. There is little hysteresis, showing that the resistance measurements of the sensors are repeatable. The data from the oscilloscope was converted into radii of curvature using Equation 5.2. A graph of this converted data can be seen in Figures 5-9.

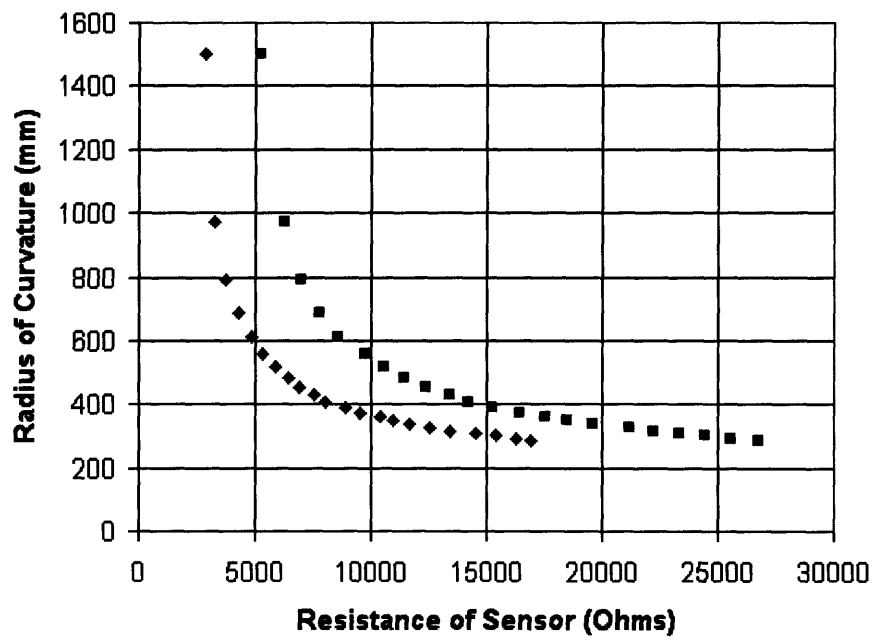

Figure 5-3: Plot of sensor resistance versus radius of curvature.

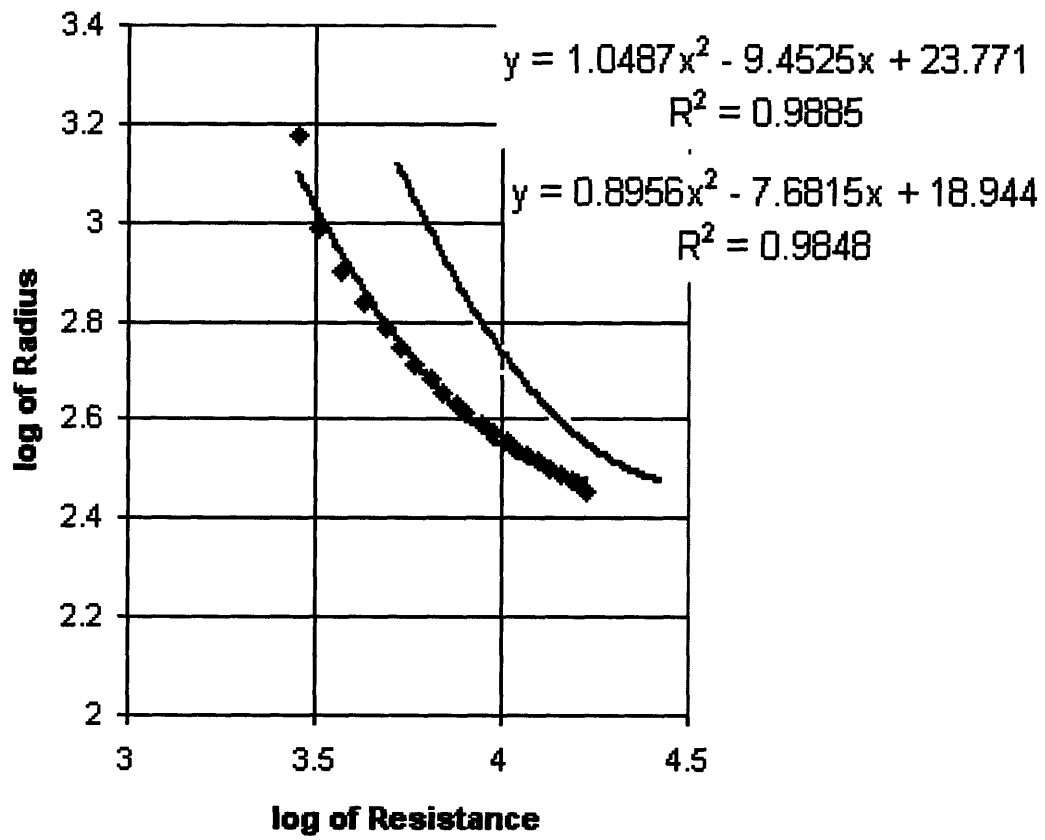

Figure 5-4: Log-log plot of sensor resistance versus radius of curvature, with best fit equations.

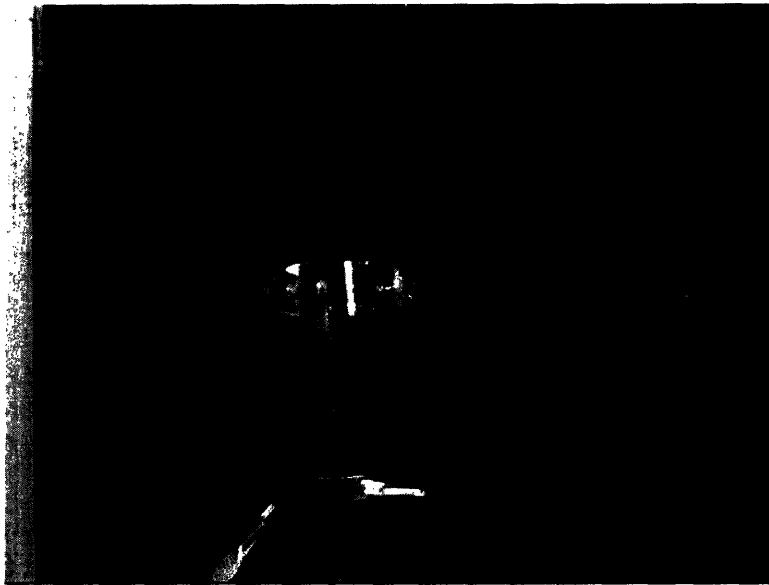

Figure 5-5: Fish is clamped in place.

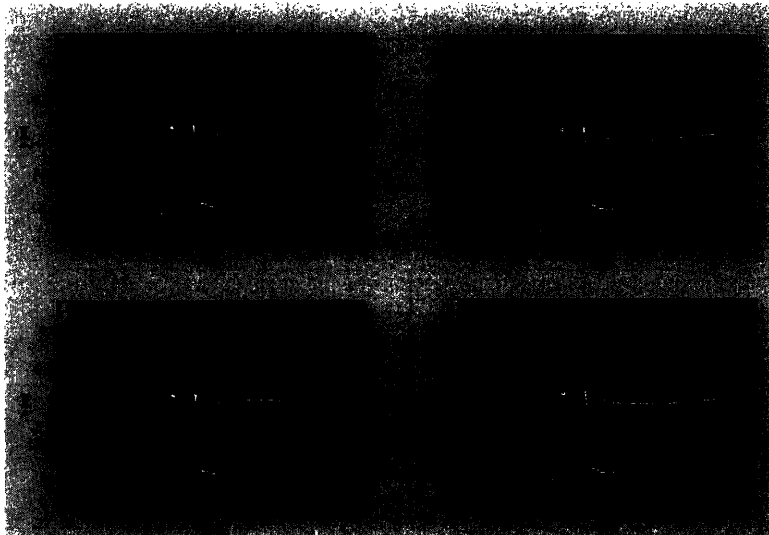

Figure 5-6: Still pictures from movie, with plots of equation 5.3 superimposed.

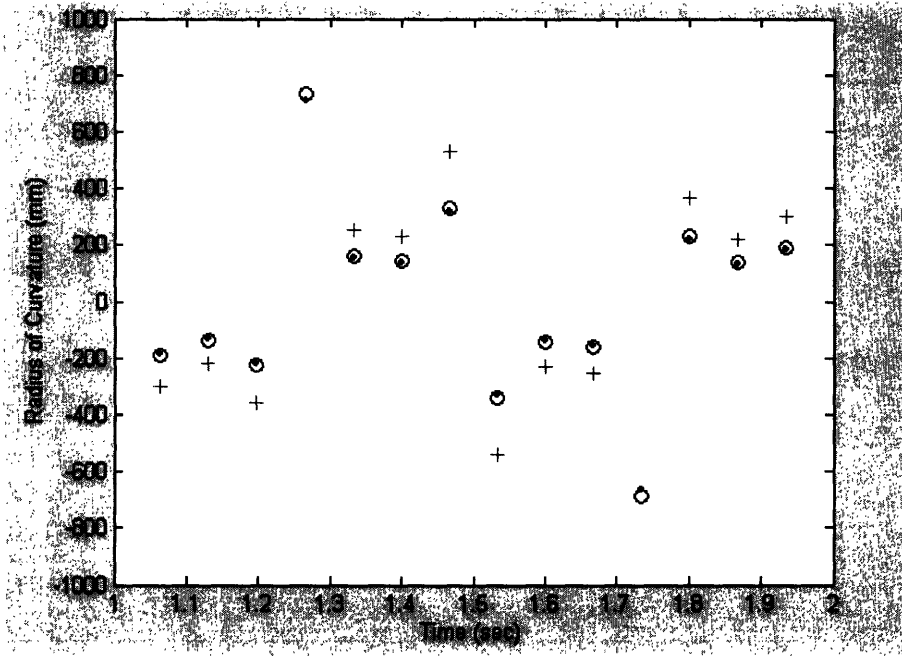

Figure 5-7: Experimental radii of curvature at 1" (+), 2" (.), and 3" (o) (location of sensors)

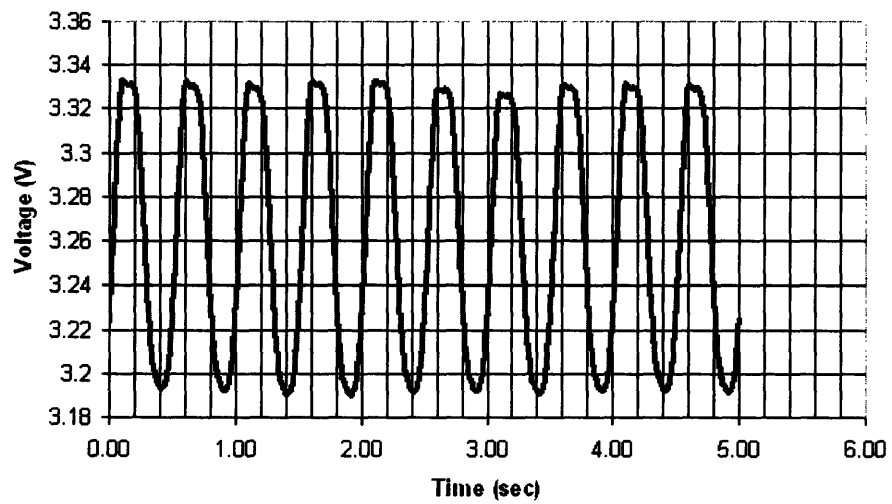

Figure 5-8: Raw data from the sensor closest to the head of the fish.

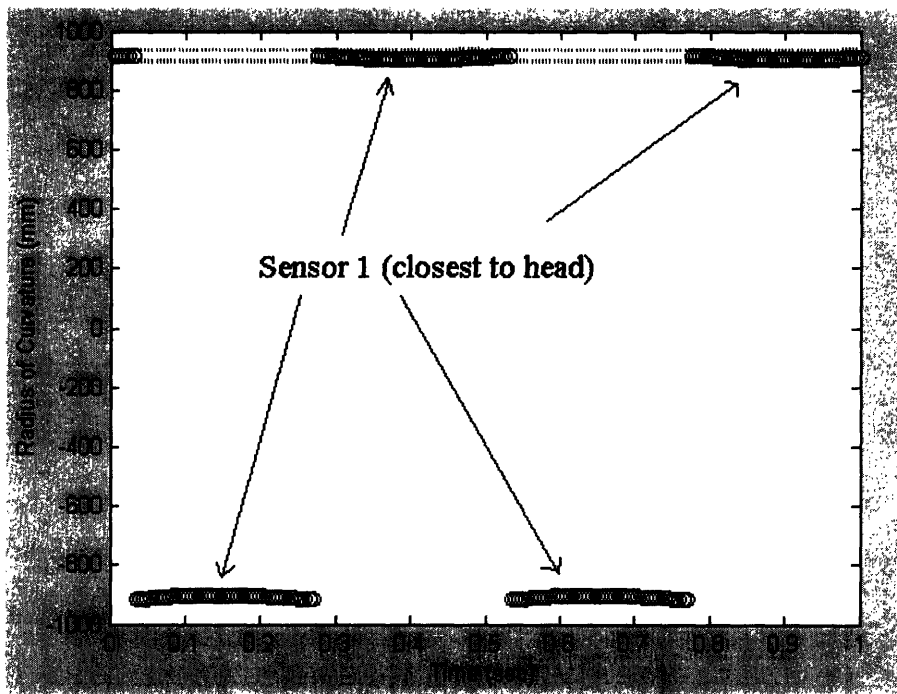

Figure 5-9: Data from sensors converted to radii of curvature.

Chapter 6

Conclusion and Recommendations

6.1 Conclusion

We selected bend sensors as the best option of sensor to place into the tail of our biomimetic device. The sensors had to first be calibrated, since they are a new type of sensor, with no supplied relation between the radius of curvature of the sensor and the resistance of the sensor. A method for encasing the sensors into the biomimetic fish was developed. Half of the silicone was poured, after curing, the sensors were aligned, and encased in a small amount of silicone. After that cured and the sensors were firmly encased, the mold was closed and the remaining silicone was poured.

A simple voltage divider circuit which was monitored by an oscilloscope was used to gather information from the bend sensors. The data from the sensors was related to the video taken from a stationary camera above the fish. While at 2 Hz, the sensor closest to the actuating plate was providing data at the correct frequencies, but at too small of an amplitude. The resistance changes of the other two sensors were too small to provide any meaningful data. Looking at the video in detail reveals that the sensors seemed to be staying stiff and not bending. This is due to the fact that the sensors are more stiff than the silicone that they are encased in. They are only bending a fraction of the magnitude that they should be.

6.2 Recommendations

The methods by which the effectiveness of the sensors was tested were difficult at times, but successful. The silicone bonded well to itself, so pouring half the mold and then the other half after the sensors had been placed worked well. The longer tail on the fish gave plenty of room to encase a good number of sensors to test. The camera adds a verification pathway, which lets the user check the actual movement of the fish.

In choosing sensors for this application for later work, bend sensors would be ideal if the fish is made of a stiff enough silicone. Otherwise, any foil sensors like strain gages, bend sensors, and possibly piezo films will not bend to match the local radius of curvature of the silicone. To use bend sensors or similar foil gages in the tail of such a biomimetic device, a stiffer silicone needs to be used so that the sensor is compatible with the tail.

There are other similar biomimetic applications where bend sensors could be implemented, besides in fish, where the calibration methods and sensors used in this thesis would be useful. These sensors could be extremely useful in monitoring analog non-rotational, non-linear motion.

Appendix A

Vendors and Suppliers Used

A.1 Sensors

Flexpoint Sensor Systems

106 West 12200 South, Draper, UT 84020

(866) 766-3539

A.2 Silicone

Quantum Silicones, Inc.

8021 Reycan Rd. Richmond, VA 23237

(800) 852-3147

Smooth-On, Inc.

2000 Saint John Street Easton, PA 18042

(800) 762-0744

A.3 Wax

Freeman Mfg. and Supply Co.

1101 Moore Rd Avon, OH 44011

(800) 321-8511

Bibliography

- [1] <http://www.mathworld.com>.
- [2] Shuo Wang Erkui Chen Junzhi Yu, Min Tan. Development of a biomimetic robotic fish and its control algorithm. *IEEE Transactions on Systems, Man, and Cybernetics, Part B: Cybernetics*, 34(4), August 2004.
- [3] P. Valdivia y Alvarado and K. Youcef-Toumi. Modeling and design methodology for an efficient underwater propulsion system. *Proceedings of IASTED International conference on Robotics and Applications*, Salzburg, Austria 2003.