

DESIGN AND EVALUATION
OF
MULTIMICROPROCESSOR SYSTEMS

by

AMAR GUPTA

B. Tech., I.I.T., Kanpur, India
(1974)

SUBMITTED IN PARTIAL FULFILLMENT
OF THE REQUIREMENTS FOR THE
DEGREE OF

MASTER OF SCIENCE IN
MANAGEMENT

at the

MASSACHUSETTS INSTITUTE OF TECHNOLOGY

June 1980

© Massachusetts Institute of Technology 1980

Signature redacted

Signature of Author _____

Sloan School of Management
May 1, 1980

Signature redacted

Certified by _____

Hoo-min D. Toong
Thesis Supervisor

Signature redacted

Accepted by _____

Michael S. Scott Morton
Chairman, Department Committee

ARCHIVES
MASSACHUSETTS INSTITUTE
OF TECHNOLOGY

JUN 13 1980

LIBRARIES

DESIGN AND EVALUATION OF
MULTIMICROPROCESSOR SYSTEMS

by

AMAR GUPTA

Submitted to the Alfred P. Sloan School of Management
on May 1, 1980 in partial fulfillment of the
requirements for the Degree of Master of Science

ABSTRACT

The next few years will witness widespread application of multi-microprocessor systems for diverse purposes. The operation of such systems is presently constrained by bus contention problems, and by increased complexity of the control program software. An interactive package is developed for analytic modeling of multimicroprocessor systems. This package adapts readily to arbitrary system configurations employing a central time-shared bus, and serves as a useful tool in the design and performance evaluation of multimicroprocessor systems.

In this thesis, the interactive package is used to evaluate four bus architectures in different job environments. The results have been cross-validated using a simulation model.

Thesis Supervisor: Hoo-min D. Toong

Title: Assistant Professor of Management

ACKNOWLEDGEMENTS

This thesis could not have been written without the encouragement, support, and insightful suggestions of my supervisor, Professor Hoo-min D. Toong; he has been a teacher, guide and friend, all in one.

I am grateful to all the members of the project team; they provided a valuable forum for all my brainstorming ideas. In particular, I would like to thank Svein O. Strommen for his relevant comments and criticisms, Tarek Abdel-Hamid for the simulation models, and Benjamin Chou for his support in the later phases.

AMAR GUPTA

May 1, 1980

TABLE OF CONTENTS

<u>Chapter</u>	<u>Heading</u>	<u>Page</u>
1	INTRODUCTION.....	5
2	IMMPS.....	12
3	APPLICATIONS AND THEORETICAL CONSTRAINTS	36
4	RESPONSE TIMINGS	52
5	VALIDATION OF IMMPS	65
6	CONCLUSION	74
	REFERENCES	76

CHAPTER ONE

INTRODUCTION1.1 BACKGROUND

As computer system complexity grows, so do total costs. Technological innovations are rapidly decreasing hardware costs, but these decreases are more than offset by investments needed to develop and/or rewrite software. Each new technology (e.g. microprocessors) results in a software "reinvention of the wheel." As this complexity increases, the labor intensive software reinvention costs escalate. For example, office computers of today have limited word processing capabilities. In order to permit graphic outputs, remote communications, audio input and output facilities and similar features that are desirable for the office computer of tomorrow, the present systems architectures will most probably have to be redesigned, and control program software developed for each new function. It is estimated that with the current 30% increase in microprocessor designs per annum, and a 100% implementation effort increase for design, the total implementation costs will exceed \$1.25 million in 1985, and more than 1,000,000 software engineers will be needed for all such applications by 1990 (34, 35).

In order to curb these escalating costs, a long term stable applications base is needed in this area. One way is to develop new architectures that support user's needs over a long growth period

with the same basic structure; the system must be modular and easy to use, and hardware changes should be transparent to the user. (This is vital since the technology is changing so rapidly). Multiprocessors, if designed properly allow this modularity, long term growth, ease of use, and possibly, as a side benefit, large computation capability.

One commonly identifies three basic motivations for the development of multiprocessors (1). These are as follows:

- a) THROUGHPUT. Multiple processors permit increased throughput by simultaneous, rather than simply concurrent, processing of parallel tasks;
- b) FLEXIBILITY. Multiple-processor systems differ from a collection of separate computer systems since the former provide some level of close-sharing of resources, e.g. shared memory, input/output devices, software libraries, not allowed by separate computer systems. Jobs, too "large" to run on a single processor, can be executed on the multiprocessor system. Flexibility also permits smooth system growth through incremental expansion by adding new processor modules;
- c) RELIABILITY. Multiprocessor systems possess the potential for detecting and correction/elimination of defective processing modules. This leads to high availability,

a key characteristic to fault tolerant systems and a fail-soft capability. Traditional fault-tolerant systems attempt to achieve both high availability and high integrity by using duplexed and triplexed functional units. (2)

The last five years have witnessed a spurt in activities relating to research and development of multimicroprocessor systems. The overwhelming factor has been the rapidly plummeting cost of semiconductor hardware (e.g. microprocessors) accompanied by an enormous increase in their computing power and capabilities. The availability of microprogrammable microprocessors has been an added boon and permits easier adaptation of microprocessors to multiprocessor systems.

1.2 PROBLEM AREAS

The following problem areas exist for uniprocessor systems:

- 1) The memory address space is too small and there is a lack of memory management and memory protection features.
- 2) Assembly language programming is difficult and extremely time-consuming for anything but the shortest program. This problem can be alleviated though, by the use of a high-level language.

- 3) The memory usage is extremely high and inefficient.
- 4) There is no capability to execute an indivisible TEST and SET instruction. This facility will be necessary for resource allocation in a multiprocessor environment.
- 5) The 8-bit word size of the microprocessor in most common usage is just too small for extended precision operations.
- 6) There is no ability to configure an operating system with privileged states or privileged instructions. An operating system would include at least a problem state and a supervisor state. (3)

Today, 16 bit word size microprocessors are available; however, several of the above problems continue to be areas of sustained research activities.

As compared to uniprocessor configurations, multiprocessor systems are characterised by increased complexity in two major areas:

a) Interconnection mechanism.

In a system with 'N' processors, if each processor is to directly communicate with every other (N-1)

processor, then $N \cdot (N-1)$ connections would be required. As the value of N increases, the number of interconnections increases as a square of N , and this makes the strategy costly to implement. The problem is identical to telephone systems wherein it was realized very early that line sharing is necessary in order to reduce costs. In the multimicroprocessor environment, such sharing has been attempted in the form of parallel buses, ring buses, cross point switches, trunk systems, and multiple buses. Haagens (5) has summarised these characteristics of these designs, and has attempted a unique split transaction Time-Shared Bus that permits a single bus to be optimized for catering to very high communication loads.

In essence, the interconnection mechanism represents the hardware facet of the problem.

b) Operating System

For optimal utilization of the processing elements, the "distributed operating system" (DOS) is now required to perform additional coordination, scheduling and dispatching functions. Further, DOS must select "the means by which computing tasks are to be divided among the processors so that for the duration of that

unit of work, each processor has logically consistent instructions and data." (6)

This must be done without replicating the program routines, and without compromising the "privacy" of the program at any stage. Finally the design must implicitly provide for graceful degradation in case any element fails. Thus each processing element should be capable of undertaking the "distributed operating system" functions. This resilience is especially critical where the system application dictates a maximum system throughout.

1.3 PRESENT WORK

The Center for Information Systems Research is involved in the design, development and implementation of a multi-microprocessor system which is hoped to be the blueprint of systems architectures for the previously outlined needs during the 1985-1995 timeframe. This system features much tighter processor coupling, higher resilience and much higher throughput than the systems under development at Carnegie-Mellon (7) and Stanford (8).

The work on this multimicroprocessor project can be divided into the following phases:

- (i) Analysis of microprocessors, and their suitability as basic elements in larger systems;
- (ii) Evaluation of existing interconnection protocols in order to identify the optimal bus architecture;
- (iii) Development of a distributed operating system;
- (iv) Final implementation.

Obviously, the above phases have considerable overlap in terms of time. Phase (i) is completed and the effort is documented in (11, 12, 13, 14, 15).

The author has been heavily involved in phase (ii). In this search for an optimum bus architecture, it was considered desirable to develop a computer-based decision support system (9, 10) to facilitate the design and evaluation process, both for interconnection mechanisms as well as for the distributed operating system. In the next chapter, this design aid is described in detail. The following chapters exemplify the use of this facility to analyze various bus architectures, and their efficacy in different job environments.

CHAPTER TWO

IMMPS2.1 INTRODUCTION

In the previous chapter, we saw that with the availability of low cost microprocessors, there is a growing trend towards multi-microprocessor systems. Presently, research is focussed on the evolution of improved inter-processor communication facilities. Whereas the constraint in single processor systems is the speed of the processor itself, the constraint in multi-processor systems is the speed of the bus used for communicating between processors. As the number of processors increases, so does the probability of simultaneous request for bus service by more than one processor. This bus contention problem has been examined among others by (5,24).

This chapter describes a tool, entitled IMMPS (acronym for Inter-active Multi-Microprocessor Performance System), developed to study single time-shared bus based multimicroprocessor systems. IMMPS, developed at the Center for Information System Research (CISR) of MIT, is an example of the use of queueing theory for the development of analytic models of computer systems. In this chapter, the model is developed, and the broad features of IMMPS outlined. Finally, the effect of a new message protocol on the system throughput are analyzed using IMMPS.

2.2 Multi-microprocessor systems

A single processor system can be represented as shown in Figure 2.1.

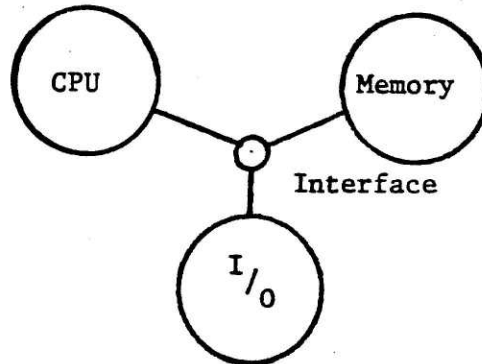

Figure 2.1 Single Processor System

When several of such mono-processor systems are connected together, any element of the system (CPU, Memory or I/O) must be capable of communicating with any other element of that system (CPU, Memory or I/O), and a typical two-processor system is shown in Figure 2.2.

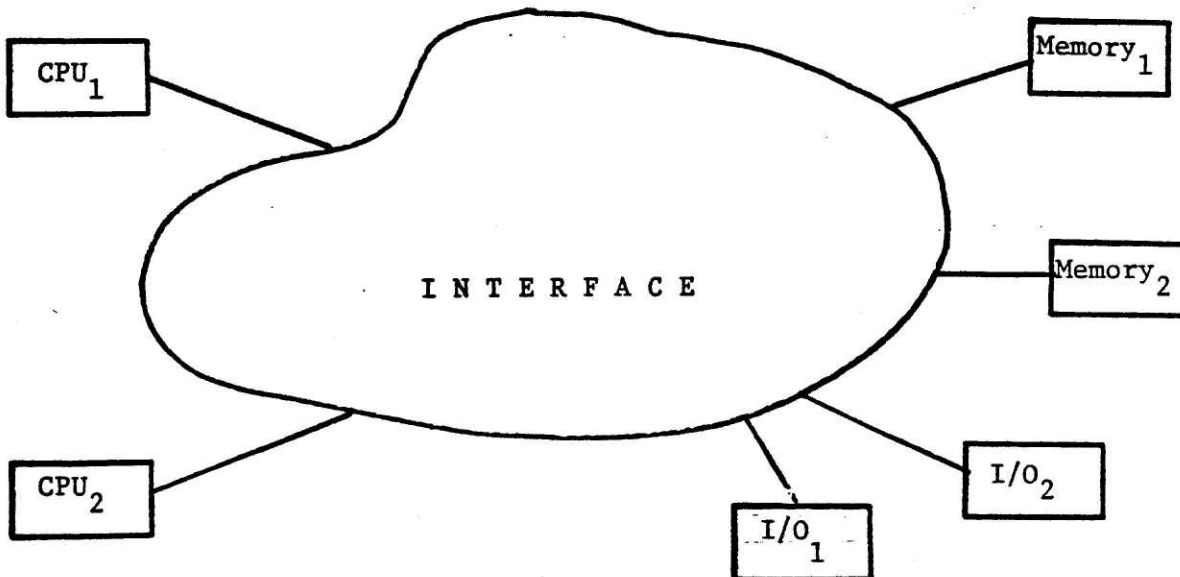

Figure 2.2 Typical Two-processor System

It is obvious that as the number of processors increases, the load on the interface increases sharply. For the mono-processor configuration shown in Fig. 2.1, the number of possible message paths is $3!/2! = 3$; for the configuration in Figure 2.2, the number of paths = $\frac{6!}{2! 4!} = 15$. Several authors have proposed multi-bus systems (Ref. 5 contains a good summary), but the cost of such multiple-bus interconnections increases as a square of the number of processors. On the other hand, if only one bus is used, the contention problem between different messages may become critical.

In order to reduce the load on the bus, it is now becoming common for individual processors to have cache memories. On the other side, the intelligence of memory and I/O units is increasing, and as such the dividing line between these elements is becoming blurred. In this thesis, devices are categorised into two major groups:

(a) Primary Processing Modules (PPM):

These are elements with higher level of intelligence; these elements control the operation of other elements. A traditional CPU is an example of a PPM: another term for such modules is "Masters";

(b) Tertiary Processing Modules (TPM):

These are elements with lower or zero level of intelligence; typical examples are memory, I/O processors. The operation of TPM is initiated and controlled by a PPM. Another term for such modules is "slaves".

In traditional single processor systems, there is one and only one PPM, and typically more than one TPM. In multi-microprocessor systems, there are several PPMs, each "controlling" the functions of a number of other TPM's, in coordination with other PPMs. The term PM or Processing Module is used to represent an element which may be either a PPM or a TPM.

The term "message" is used in the literature to represent a wide spectrum of communication levels. In this thesis, messages are considered to be of one of the following two main types:

- (a) "m-message"(short for macro-message). This type of message is initiated by any PPM, and includes all the resulting supplementary processes and communications that are directly attributable to the PPM's command. In general, an m-message will involve one or more PPMs, several TPMs and a sequence of bus usages disjoint over time.
- (b) "e-message" (short for elementary-message). Such messages require a single usage of bus, and involve only two PMs (both PPMs or both TPMs or one PPM and one TPM). An example of e-message is a simple "WRITE" from a processor to a memory. Essentially, an e-message denotes the most elementary message communication between two processing modules.

In general, each m-message will result in one or more e-messages. A simple store of type Register to Memory (direct addressing) will usually result in a single WRITE message that includes the value to be written. This is an example of an m-message resulting in a single e-message. On the other hand, a READ-MODIFY-WRITE sequence may be a single m-message, but would necessarily involve a sequence of e-messages.

2.3. PARAMETERS FOR THE MODEL

IMMPS is designed specifically for the analysis of any multi-microprocessor system with a single time-shared bus. Such networks, with 'p' primary processor modules and 't' tertiary processing modules can be depicted as shown in Figure 2.3.

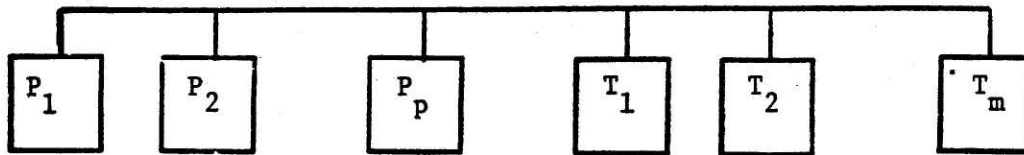

Figure 2.3 Typical single bus multimicroprocessor configuration

An equivalent representation is depicted in Figure 2.4. Here, an m-message is generated by a PPM, and transmitted as an e-message on the bus to a pre-specified PM (PPM or TPM). After appropriate processing at this PM, another e-message may be transmitted to a definite PM via the bus. In general, this process is repeated several times, and a given PM may be accessed zero, one or more times.

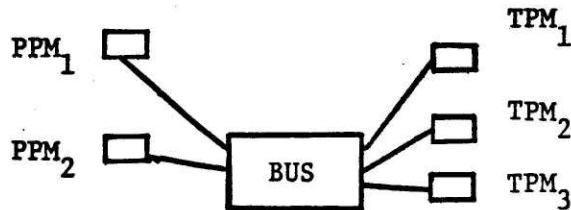

Figure 2.4 Equivalent single bus multiprocessor configuration

The m-message ends with either a reply to the initiating PPM (similar to an answer to a customer's query at an automated bank teller) or it just "dies" in the network after all the specified operations have been carried out. The total existence time of an m-message is analogous to the concept of system response time and will depend on the bus service time, PM service time (time taken for the processing), and the wait times (waiting because the facility is busy) at both PMs and the bus. The model uses the following input data:

Messages:

- number of message types (either as e-messages or m-messages or any appropriate combination provided a given physical message is not repeated)
- the frequency (arrival rate) and priority of each message type.

System configuration:

- the system configuration in terms of numbers of different PPMs and TPMs.
Details of similar PMs (e.g. memory units with same access time) have to be specified only once
- the bus time (also called service time) required to transmit a message (may be different for different messages);
- average processing time for each PM.

In case, the system has been specified in terms of m-messages, the movement path of each type of message (number of requests to each PM) must be specified. For example, a credit query request may result in two accesses to a particular PPM and four accesses to a particular TPM.

2.4. QUEUEING NETWORK MODEL

The configurations indicated in Figures 2.3 and 2.4 earlier can be represented by the central server model depicted in Figure 2.5. This is a system with a single bus and multiple processing elements.

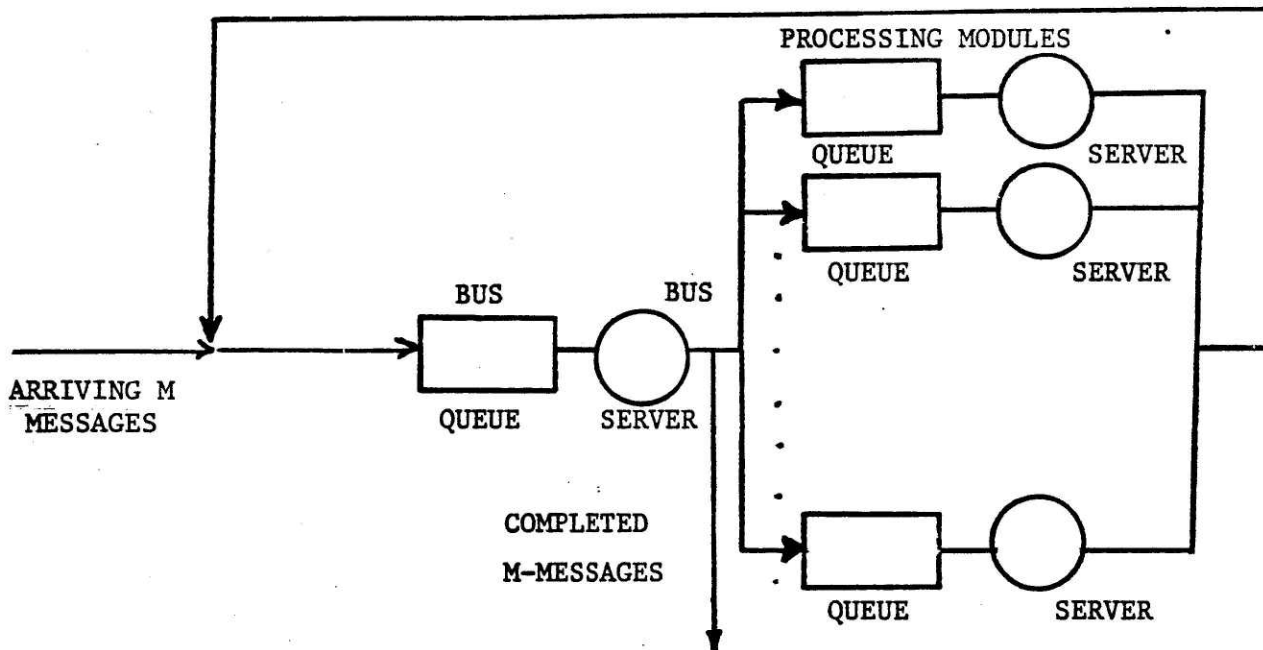

Figure 2.5 The Multi-microprocessor model

The term "server" refers to any PM or to the bus. Each of the elements is represented by a circle, and the rectangles in front of the circles (servers) represent queues of messages of that specific server. Different types of m-messages enter the system and are then regarded as entities which circulate through the network, making requests (e-messages) for processing from each server they encounter and waiting in queues at times when they make a request

to a busy server. Different messages may be assigned different priorities, or several messages may share the same priority. This affects their chances of getting the bus. A "m-message" may cause several "e-message" involving various processing modules.

The following variables and indices are used:

- Index i denotes a specific processing module ($1 \leq i \leq n$)
- Index j denotes a specific message (m or e type) ($1 \leq j \leq m$)
- Index k denotes a specific priority ($1 \leq k \leq \ell$)
- q denotes a priority level ($1 \leq q \leq \ell$)
- n number of PM in the system configuration
- m number of message types
- ℓ number of priority levels ($\ell \leq m$), ℓ is assumed to be lowest priority.
- a_i gross arrival rate of messages to element i
- a_j gross arrival rate of type j messages in system
- a_k arrival rate of messages with priority k
- s_i service time of module i
- s_j gross bus service time for message j
- s_j^k bus service time per e-message from message j of priority k
- s_k average bus service time per e-message of priority k
- NR_{ij} number of e-messages due to m-message " j " to element i
- Q_i queue length of device i
- Q_k queue length of priority k at the bus
- R_i response time of element i
- R_{Dj} total device response time for m-message j
- R_{BUSj} bus response time for m-message j

- R_j total system response time for m-message j
 R_k average bus response time for m-message k
 U_i utilization of element i
 U_k bus utilization by messages of priority k
 U_{sk} weighted bus utilization by messages of priority k

2.4.1 Formulae for bus evaluation

Assuming exponential distribution of interarrival times of messages, exponential distribution of service times required per message, and a single central server (summarized as M/M/1 model), the following formulae are valid:

$$\begin{aligned}
 a_k &= \sum a_j && \text{Y} && \text{sum up only those } a_j, a_j s_j' \\
 s_k &= (\sum a_j \cdot s_j') / (\sum a_j) && \text{Y} && \text{with given priority k} \\
 U_k &= a_k \cdot s_k && \text{Y} && \\
 U_{sk} &= \sum a_j \cdot s_j^2 && && \\
 R_k &= s_k + \frac{\sum_{q=1}^k U_{sq}}{1 - \sum_{q=1}^k a_q \cdot s_q} && && \\
 Q_k &= R_k \cdot a_k && &&
 \end{aligned}$$

2.4.2 Formulae for device/element evaluation.

For a M/M/1 model, and a first come-first serve (FCFS) discipline, regardless of message type and priority, the formulae, for the respective expected values, are as under:

$$U_i = a_i \cdot s_i$$

$$Q_i = U_i / (1 - U_i)$$

$$R_i = s_i / (1 - U_i)$$

2.4.3 Formulae for evaluation of individual messages:

The response time for a specific message is composed of two parts: the total PM response time for that message and the bus response time for that message. The formulae for these components and the total response time are shown below:

$$R_{Dj} = \sum_{i=1}^n R_i \cdot NR_{ij}$$

$$R_{BUSj} = (R_k - s_k + s_j') \left(1 + \sum_{i=1}^n NR_{ij} \right)$$

$$\text{where } s_j' = \frac{s_j}{1 + \sum_{i=1}^n NR_{ij}}$$

$$\text{Finally, } R_j = R_{Dj} + R_{BUSj}$$

2.5. SALIENT FEATURES OF IMMPS MODEL

The Interactive Multi-Microprocessor Performance System (IMMPS) is a modified and expanded version of the central server queueing model developed by (25,26). Salient features of the new model will now be discussed:

2.5.1 Queueing Network Model:

IMMPS is a queueing network model based on a Poisson distribution of message generation. The Poisson assumption is close to reality, and gives accurate results (27). It is the only continuous distribution with the "memory-less" property, and further it leads to relatively simple mathematical formulae. The arrival rate is assumed to be constant and homogenous, and these assumptions have generally given results within 10% of observed results. (28)

2.5.2 Interactive operation:

The program is written in FORTRAN and operates in an interactive mode. System commands and data parameters can be input in the interactive mode, filed for later use in the file mode, and readily modified in the edit mode. User is prompted to respond by easy to understand questions.

2.5.3 System configuration:

Presently, IMMPS is set up to accept a maximum of 100 processing modules. This limit can be easily increased, when larger configurations are analysed.

2.5.4 NACK and TIMEOUT implementation:

In the latest implementation of the model, the NACK (short for not acknowledged - results in case of parity busy, incorrect address

for receiving PM or when receiving PM is busy) and TIMEOUT (no reply signal received in pre-specified time duration) are also implemented. Values for these parameters can be inserted and varied by the user.

2.5.5 Average Response Time:

The model outputs average response times for the bus and individual processing elements, plus the average (expected value) queue lengths at various devices. The computed results are arranged by message type and also by PM type. For initial design, the use of average response time as a ballpark figure is sufficient. Later, when various system parameters are known more accurately, actual individual figures help in a better comprehension of the entire system.

2.5.6 Sensitivity analysis and graphical outputs:

After obtaining results for a specific configuration, various parameters (e.g. bus speed, NACK rate, TIMEOUT rate) can be modified and a new output obtained. An easier alternative is to use the option of sensitivity analysis and graphical output. The user can specify the independent variable, the step size (as a percentage of initial value), the number of iterations or graphical points (maximum of 99), and the range for the average response time which is the dependent variable. The latter, and the type of graph points, can either be specified by the user or pre-programmed default values are assumed.

2.5.7 Elaborate warning and error detection routines;

All user specified values are checked, to the extent possible, for correctness and compatibility with other values. User is prompted

in case of errors/potential errors, and amendments are easily done in EDIT mode.

2.5.8 Infinite queues:

An assumption is made that there is no upper limit on the queue lengths at input/output of different PMs. This is done because finite/queue capacity problems can be mathematically solved only for some cases. A companion simulation model has been used at MIT for finite queue capacity system analysis, and these results have been very close to the values predicted by IMMPS [Ch5]. However, it is true that if average queue lengths (as computed by model) are smaller than one-tenth the physical maximum queue size (engineering approximation), then the assumption of infinite queue capacity is valid for purposes of design.

To calculate the mathematical probability of the "goodness" of this assumption, consider the situation at any PM of the bus as shown in Figure 2.6.

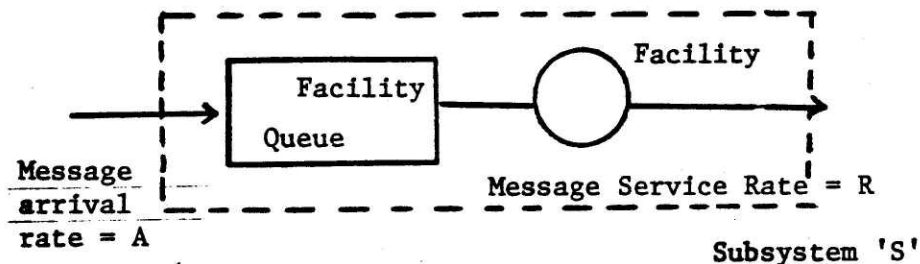

Figure 2.6 A Typical System Facility

Messages arrive at a rate of A per unit time, and are processed/serviced at a rate of R per unit time. For mathematical simplicity, assume that both arrivals and processing timings are exponentially distributed. The sub-systems is therefore of type $M/M/1$, where

the first M means that the inter-arrival times are exponentially distributed (M stands for "Markovian"), the second M that the service/processing times distribution is also exponential, and 1 means that the server has one channel. No output queue is considered, as this wait time is considered to be due to the input queue of the next facility (bus or PM).

Let

p_0 = probability of no message in sub-system S
(i.e. service facility is free, and queue is empty),

p_1 = probability of 1 message in sub-system S
(i.e. service facility is busy, but queue is empty),

p_2 = probability of 2 messages in sub-system S
(i.e. service facility is busy, and one message awaits processing); and

p_N = probability of N messages in sub-system S (i.e. service facility is busy, and (N-1) messages await in the queue

Then
$$\sum_{N=0}^{\infty} p_N = 1$$

Also, the traffic intensity, $T = \frac{A}{R}$
(by definition).

For the M/M/1 case, the following formulae are valid (28,29,30)

$$p_0 = 1 - T$$

$$p_N = (1 - T) T^N$$

$$\bar{N} = \frac{T}{1 - T}$$

$$\text{Var } (N) = \frac{T}{(1 - T)^2}$$

$$p(N \geq k) = T^k$$

Using IMMPS, suppose the average number of messages in the system, $N = 2$ (including the message being serviced) which gives the traffic intensity, $T = 2/3$.

If using the previous logic, the actual queue capacity was 10, the maximum value N can attain physically is 11. The probability of an error due to the assumption of infinite queue capacity is given by:

$$P\left(\begin{array}{c} \text{Approximation} \\ \text{Error} \end{array}\right) = p(N \geq 12) = T^k = \left(\frac{2}{3}\right)^{12} < 0.78\%$$

Hence, the error due to the infinite queue capacity assumption is really very small. If the queue length is set to 64 (not too difficult to realize) the probability of queue overflow becomes essentially zero, 2.4×10^{-12} . At the same time, it must be emphasized that the hardware implementation must prohibit receipt of any new message if the queue is filled to capacity. The predicted through-put using IMMPS would be very slightly higher than actual through-put using IMMPS with finite queues.

2.5.9 Arbitration modes:

In any real multi-microprocessor system, there will always be occasions when several PMs want to use the bus at the same time. In order to permit meaningful operation, there must be logic, either centralized or decentralized, to grant the bus to a par-

ticular PM. This process is called arbitration. Figure 2.7 depicts a case where an arbitration cycle is carried out every time the bus becomes free. The arbitration cycle

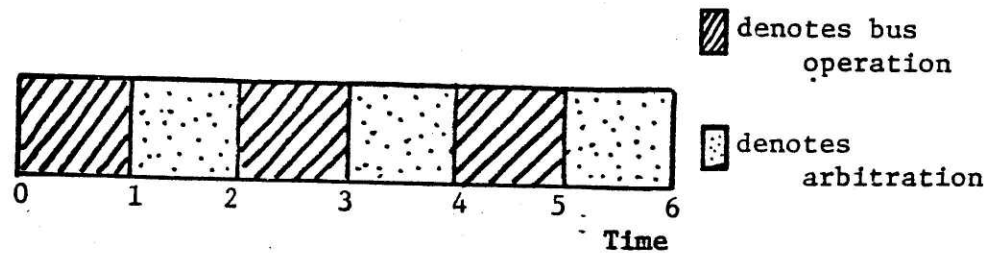

Figure 2.8 Effect of arbitration cycle

and the bus service time are each assumed to be one unit time long. In this case, the bus is actually used for 3 units of time out of 6 units of time, i.e. for 50% of cycles; the remaining time, arbitration is in progress, and the bus is forced to be idle.

One way to increase bus throughput would be to permit overlapping of bus operation and the arbitration cycle. Such a case is shown in Figure 2.8.

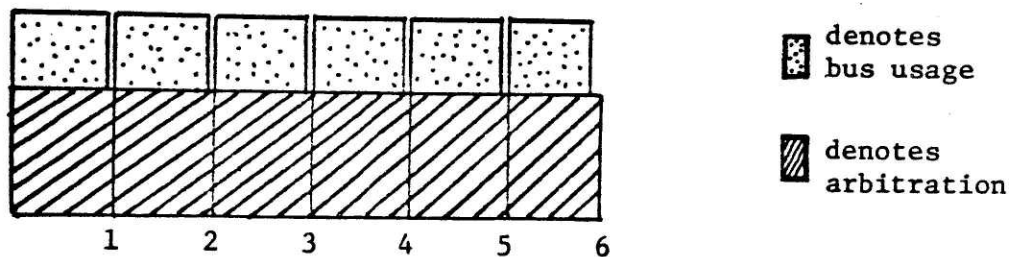

Figure 2.8 Overlapped operation

When the bus is being used, the arbitration unit decides the next PM to use the bus. As soon as the bus becomes available, the PM starts using the bus, and the arbitration cycle starts afresh to decide the next candidate for using the bus.

In case of fully overlapped operation, the bus is available for use at all times, and the throughput is not adversely affected by the arbitration overhead. In case of non-overlapped operation, the arbitration overhead is taken into account by assuming the bus service time to be the sum of the actual bus service time plus the arbitration overhead.

2.6. IMPLEMENTATION OF A SPECIFIC BUS STRUCTURE

2.6.1 NACK and TIMEOUT

Taking clues from telecommunication experience, a certain percentage of NACK and TIME-OUT must be expected in any practical multi-microprocessor system. A NACK occurs due to incorrect parity or the queue being full at the receiver's end. An incorrect destination code, non-operational telecommunication link or a faulty device would result in a TIME-OUT. System software normally re-transmits the message, for a pre-specified number of times, before informing the user. Suppose, the probability of getting an ACK, a NACK and a TIMEOUT are P_A , P_N and P_T as shown in Figure 2.9, 2.10 and 2.11 respectively.



Figure 2.9 Case 1: ACK

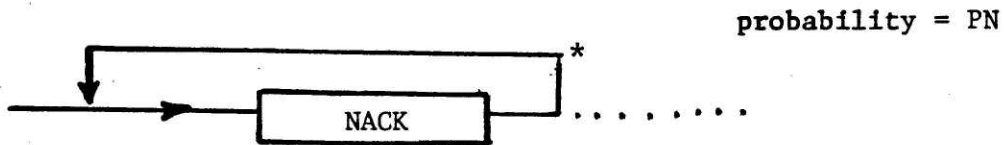

Figure 2.10 Case 2: NACK

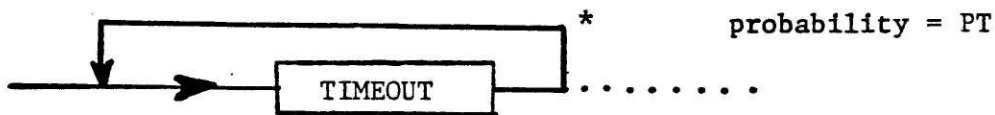

Figure 2.11 Case 3 TIMEOUT

*NOTE: (Figures 2.10 & 2.11)

In NACK and TIMEOUT, message must be re-transmitted. Input load correction is therefore necessary.

In the last two cases, the messages are re-transmitted and the total system load is therefore greater than the physical arrival rate. In fact the bus is busy for a total time T where

$$T = [p_A \cdot t_A + p_N \cdot t_N + p_T \cdot t_T] \cdot L$$

where

t_A = average bus time for an ACK message;

t_B = average bus time due to a NACK message

(the message "re-enters" system and an ACK message must finally be transmitted);

t_T = average bus time for a TIMEOUT message (the message "re-enters" system and an ACK message must finally be transmitted).

L = system load corrected for the "re-entered" messages as shown in Figure 2.12.

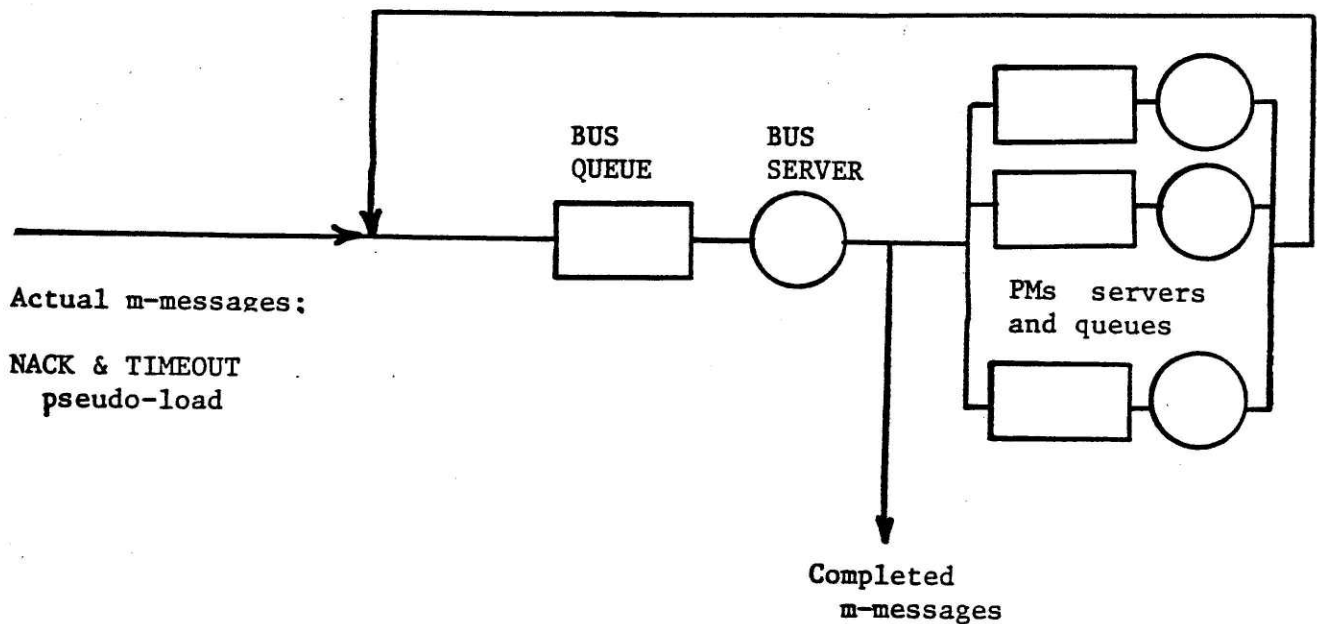

Figure 2.12 Corrected System Load

2.6.2 Workload Characterization - An Idealized Case

Consider a multimicroprocessor configuration with 10 processors (PPM) and 10 memory units (TPM) all sharing a single bus. For this case assume the memory service time (read/write) is 500 nanoseconds, and the bus service time is 100 nanoseconds. Assume that each processor makes 1.4 accesses to memory every microsecond, and all memory units are used equally on the average (i.e. a uniform distribution of processor requests to the 10 memories - Figure 2.13).

In the specific case described above, there are 1.4 messages per processor per microsecond, or a total of (1.4 messages/processor/microsecond) X (10 processors) X (10^6 microsecond/second) = 14×10^6 messages per second. Using traditional methods of memory access, each message keeps the memory busy for (1 bus service time + 1 memory service time + 1 bus service time) = (100 ns + 500 ns + 100 ns) = 700 ns. Using values of service time and message arrival rate, IMMPS analysis indicates that the bus utilization exceeds 97%, causing an average wait time exceeding 12 microseconds, and the response time for each memory access of almost 13 microseconds.

The same workload was next analyzed, with the aid of IMMPS, in a Pended Transaction environment (5). In this case, the m-message consists of the following:

- (i) An e-message from processor to memory
- bus service time of 100 ns;
- (ii) Actual memory access
- memory service time of 500 ns;
- (iii) An e-message from memory to processor
- bus service time of 100 ns.

IMMPS generated the following results:

(i) Response time for first e-message	= 119.23 ns
(ii) Memory response time	= 537.31 ns
(iii) Response time for reply e-message	= 119.23 ns
	<hr/>
Total time for transaction	775.77 ns
	<hr/>
Bus Utilization	= 27.78%

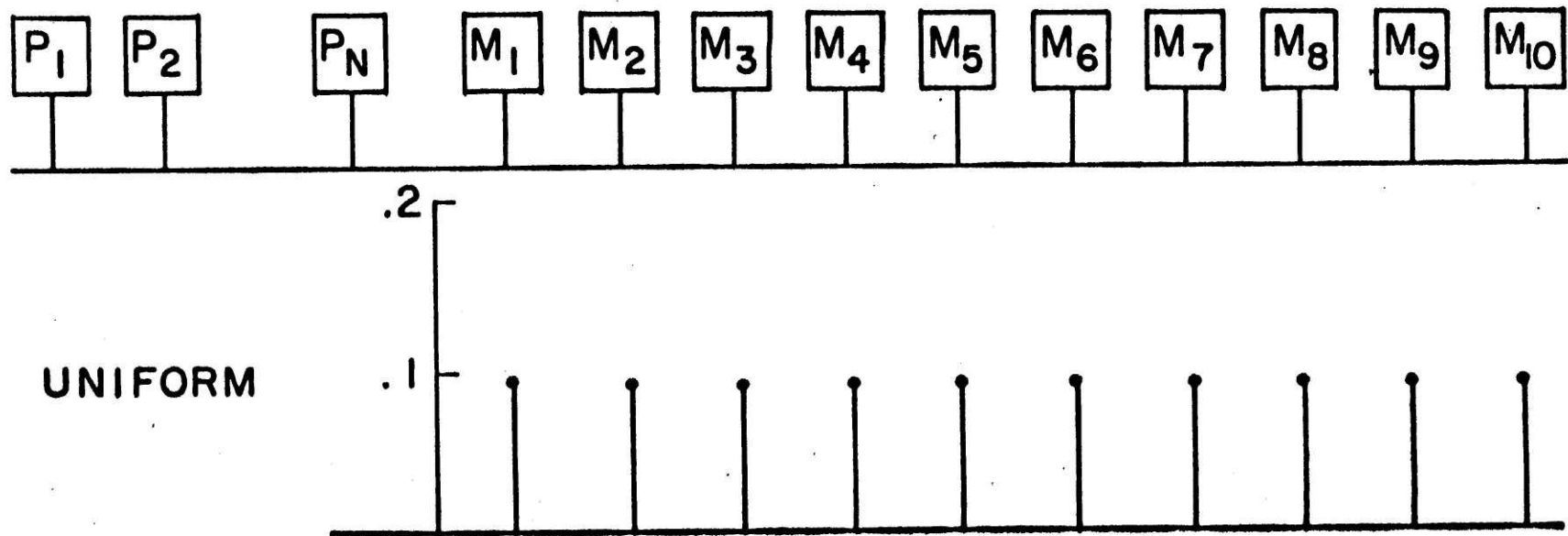

FIGURE 2.13

It is seen that for the particular datapoint assumed, the Pended Transaction protocol drastically reduces the response time (from 13 microseconds to less than 1 microsecond) and the bus utilization from 97% to 28%.

It is fairly simple to include the impact of NACK and TIMEOUT on the system behavior. Assume that there is a 1% probability of NACK and TIMEOUT each. One can then create dummy messages with a frequency of 1% of actual messages, (1% of 14×10^6 messages/second or 0.14×10^6 messages/second), and these messages have a bus service time equal to the ACK service time, or a different service time depending on how the system hardware and software behave when an abnormal condition is detected.

2.6.3 Workload Characterization - Another Case

In the previous sub-section, specific values of service times and transaction rates were assumed. These values are dictated by the system architecture and the particular job environment. Here, we consider a more realistic case.

The future will witness increased usage of speech recognition and voice answer back systems. Consider the system in which speech inputs are used as commands/queries to a data base, and the answers are "spoken" by the computer, followed by a prompt to the user for the next question. In a distributed system, the configuration may be as depicted in Figure 2.14. In this case, the maximum data input and data output rates are less than 8 KB/sec each. The total load on the bus is 16 KB/sec. If the same data base were now to be accessed by say 60 users simultaneously (e.g. airline reservations or automated bank tellers), there will be a worst case of 60 such loads of 16 KB/sec. Knowing the bus service time and disk service time, all input parameters for an IMMPS analysis are now available and could be used to evaluate the performance of different communication protocols.

At MIT, IMMPS has been used to study several multimicroprocessor applications likely to become widespread by the late eighties.

2.6.4 Homogeneity Assumption

A final IMMPS consideration must deal with the time-history dependence of m-messages. In several instances, the number of m-messages, or the input queries, is not an autonomous variable, but is dependent directly on the previous system response. For example, if a bank teller responds after a

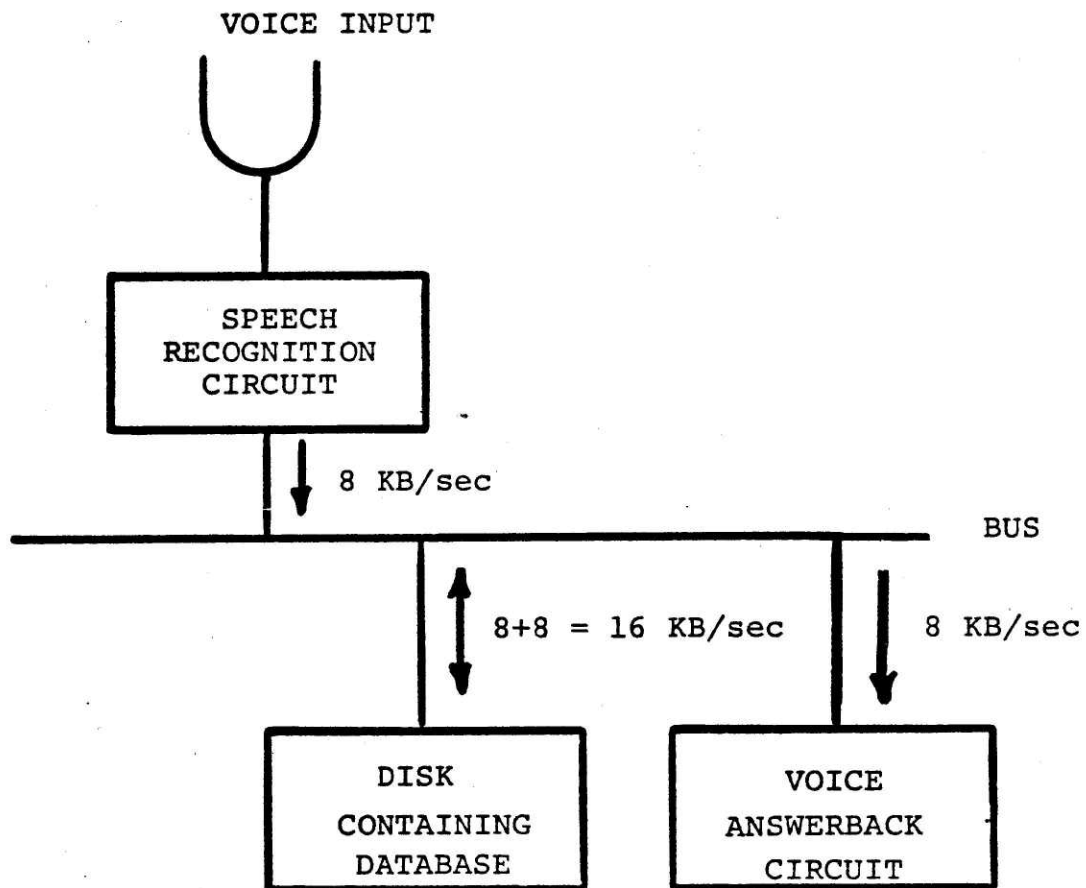

A Typical System
Figure 2.14

wait of one hour, the number of user queries will be much lower than a case where the teller responds in one second. This feedback effect cannot be explicitly accounted for within IMMPS, but can be indirectly accounted for by considering different time-periods with their own characteristic input loads.

When designing future systems to cater to particular applications, the effort is geared towards identifying system protocols that operate comfortably with the prescribed workloads, and in addition have sufficient margin to cater to incidental overloads. This implies that the response times are within reasonable limits, and the users are able to do their work on an undiminished basis. It is best to consider the maximum transfer rates of peripherals while evaluating the bus loads, as this results in maximum contention and the longest response timings. In such a case, one gets the worst case behavior of the system, irrespective of the heterogeneity of the workload involved.

CHAPTER THREE

APPLICATIONS AND THEORETICAL CONSTRAINTS3.1 INTRODUCTION

In the preceding chapter, IMMPS was described in some detail, and its relevance for multimicroprocessor system design and evaluation was outlined. While analyzing multimicroprocessor bus architectures, one is soon confronted with questions related to the job environment in which these systems are expected to operate. Computer performance evaluation has traditionally classified environments (27) as Scientific (high CPU loads, and negligible Input/Output) or Commercial (low CPU loads, high I/O). The literature generally neglects evaluation of real-time systems altogether. The future will witness new uses of the computer technology, such as in areas of speech recognition, audio response, word/graphics processing and real-time movies. For such applications, the simple categories of Scientific versus Commercial are neither pertinent nor useful. Instead, from the vast continuum of applications, one identifies discrete applications to serve as benchmarks in the design and evaluation process. In this chapter, four discrete application reference points are identified and described.

To the above "primal" problem, the "dual" aspect is equally important. One doesn't wish to reinvent the wheel, if some previous wheel can serve the purpose, possibly with some modifications. In

the case of computer communications, the Synchronous Data Link Communication (31) has been in usage for some time, and it would be pertinent to evaluate the efficacy of SDLC for the particular applications. In (5), an innovative parallel bus has been outlined, and this PENDED architecture is also evaluated in this thesis. Finally, a leading computer manufacturer has come up with another parallel bus that bears at least some resemblance to PENDED; this design is codenamed "Q" in this thesis.

In this chapter, we focus on the theoretical capacities of "Q", PENDED and SDLC bus architectures. The efficiency or suitability of any bus architecture is usually examined in terms of the actual throughput and response timings. In the ideal case, the messages will not be required to wait, and the response time will equal the service time. Also, if one can control the actual arrival time of all individual messages, the bus can be loaded continuously, or the bus utilization increased to one. In such a case, the bus throughput is implicitly dependent on the protocol overhead and the data transfer data. It is obvious that any real life situation will yield throughput lower than the maximum under the ideal conditions enunciated above. One must therefore undertake a deeper analysis only if the "maximum throughput" is at least adequate for the intended application.

3.2 Datapoints

The adequacy angle raises the implicit question of "adequate for what?" In [17], the analysis was focused around a graphic display application depicted in Figure 3.1. The total data transfer rate, excluding CE load, is

DATAPOINT 1

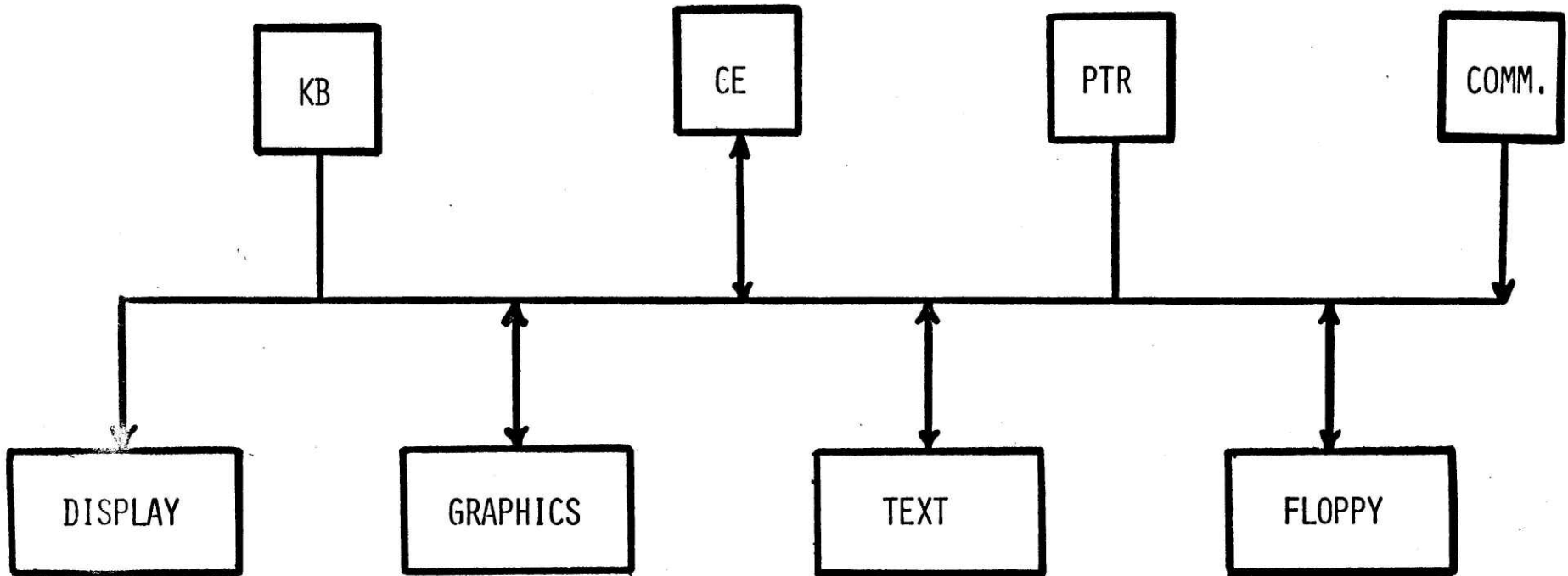

TOTAL LOAD ON BUS

$$\begin{aligned} &= \text{COMM.} + \text{FLOPPY} + \text{TEXT} + \text{GRAPHICS} \\ &= 125 + 40 + 40 + 75 \text{ KB/S} \\ &= 280 \text{ KB/SEC.} \end{aligned}$$

FIGURE 3.1A

TOTAL DATA LOADS ON BUS FOR VARIOUS DATAPOINTS

DATAPoint 1

COMM. → FLOPPY	125 KB/S
FLOPPY → TEXT	40 KB/S
TEXT → GRAPHICS	40 KB/S
GRAPHICS → DISPLAY	75 KB/S
KEYBOARD } PRINTER }	NEGLIGIBLE
	<hr/>
	280 KB/S

FIGURE 3.1 (B)

280 Kilobytes per second.

Figure 3.2 depicts a text scrolling application, and the total data transfer rate is now about 10.7 Megabytes per second. Figure 3.3 shows a configuration similar to Figure 3.1, but with additional capabilities for speech recognition and voice answer back; the data transfer rate aggregates to 1.7 Megabytes per second.

Finally, in Figure 3.4, we have the real time color movie. Assuming that a single memory contains all the data, the total bandwidth requirements are now 47.3 Megabytes per second.

The four applications described above are used as the data reference points for calibrating the response times possible through implementing the alternative bus architectures.

3.3 THEORETICAL CONSIDERATIONS

For each of the various bus architectures ("Q", PENDED and SDLC) there is a definite upper bound to the data transfer rate that can be sustained under the most ideal conditions. This upper bound is determined by circuit speeds, the width of the data transfer path, and the implicit overheads inherent in flags and arbitration. In this section, these upper-bound values are determined as a function of the message size.

3.3.1. "Q"

At the present time, the message size has no known bounds, and several possible cases are therefore considered. In case only one data byte is transferred per message, the actual message size is 3 frames with the first two frames being header frames, followed by the data frame. Including arbitration, the transfer time, or the time for which the bus is unavailable to others, is about 1.33 microseconds. Hence, the maximum data transfer rate equals:

$$\frac{1 \text{ data byte/message}}{1.33 \text{ microseconds/message}} = 0.75 \text{ Megabytes/second}$$

DATAPOINT 2: TEXT/IMAGE PROCESSING

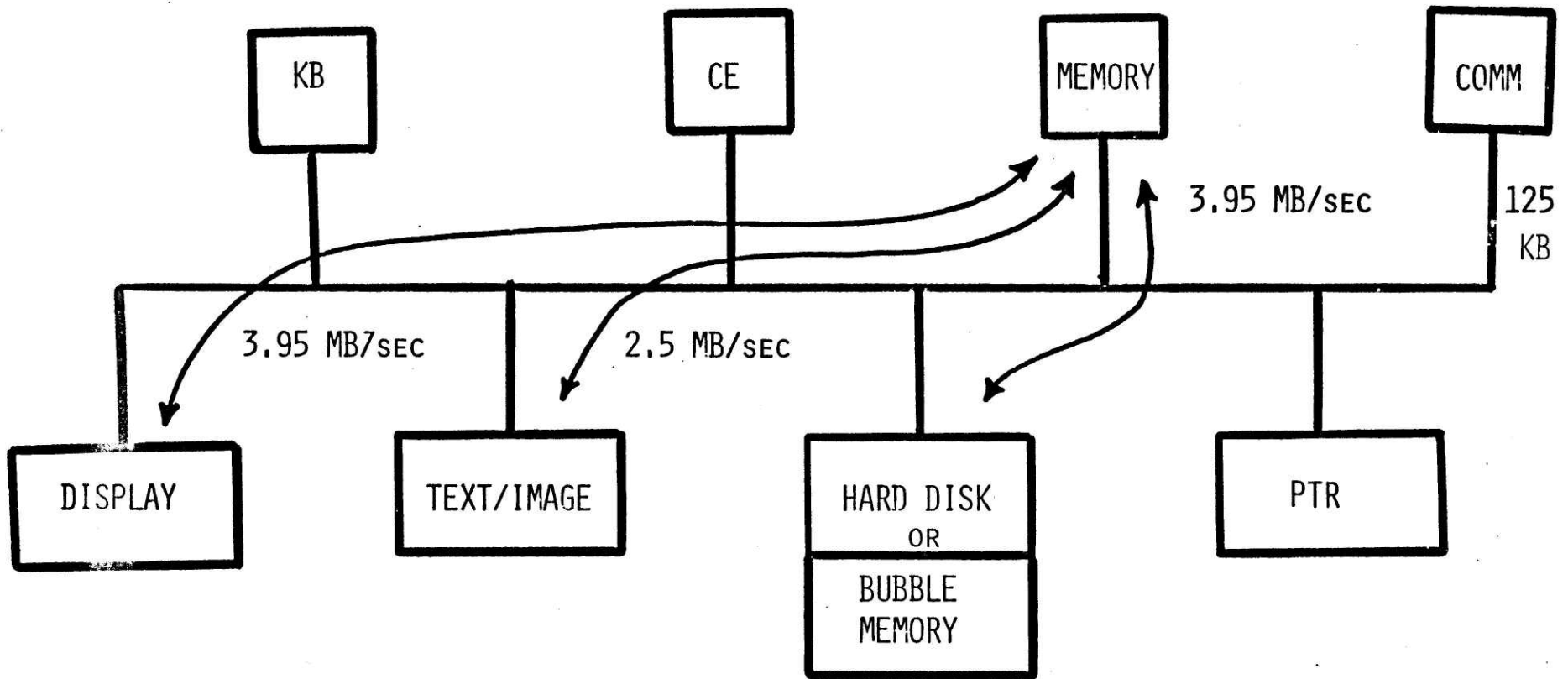

$$\text{TOTAL LOAD} \approx 3.95 + 3.95 + 2.5 \text{ MB/SEC}$$

$$= 10.4 \text{ MB/SEC}$$

FIGURE 3.2 (A)

DATAPOINT 2

TEXT/IMAGE PROCESSOR

MEMORY ↔ DISK	3.95 MB/S
MEMORY ↔ DISPLAY	3.95 MB/S
MEMORY ↔ TEXT/IMAGE	2.5 MB/S
OTHERS	NEGLIGIBLE
	<hr/>
	10.4 MB/S

FIGURE 3.2 (B)

DATAPoint 3: TEXT + SPEECH

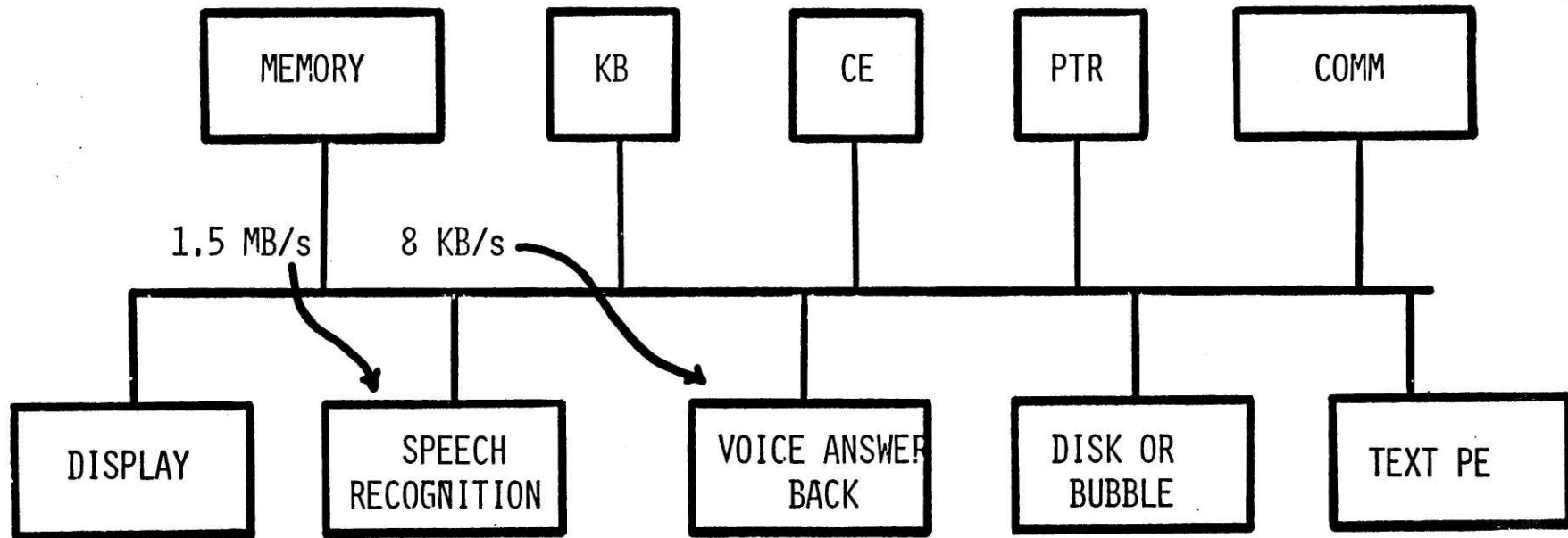

$$\begin{aligned} \text{TOTAL LOAD} &= \text{DATAPoint (1)} + 1.5 \text{ MB/s} \\ &= 1.7 - 1.8 \text{ MB/s} \end{aligned}$$

FIGURE 3.3 (A)

DATAPoint 3

TEXT EDITOR WITH SPEECH RECOGNITION & VOICE ANSWER BACK

⇒ DATAPoint 1 + ADDITIONAL DATA LOAD OF 1.5 MB/S

= 1.7 - 1.8 MB/S

≈ 6 TIMES THE LOAD OF DATAPoint 1

FIGURE 3.3 (B)

DATAPOINT 4: MOVIE !

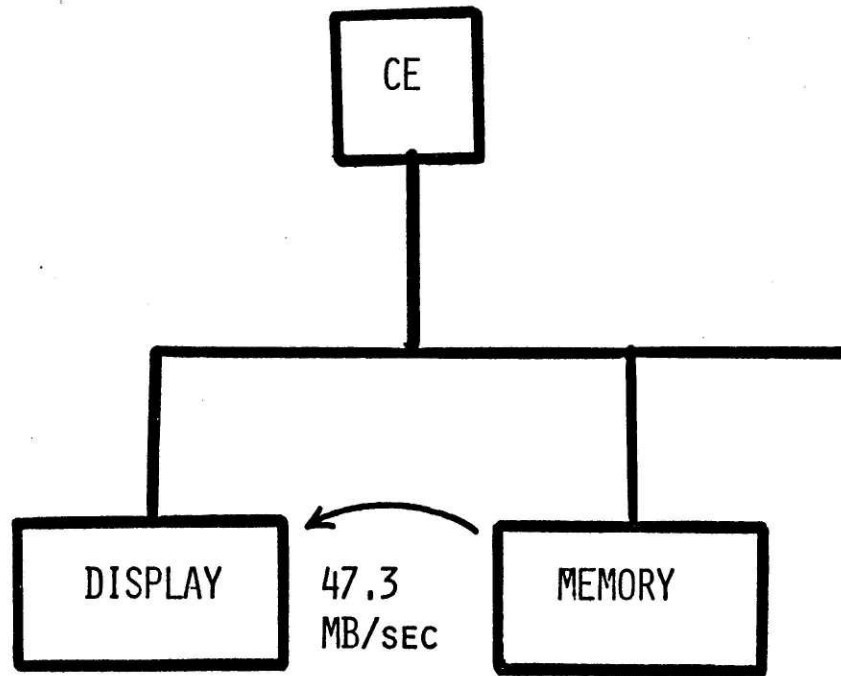

TOTAL LOAD \approx 47.3 MB/SEC

FIGURE 3.4 (A)

DATAPOINT 4

REAL TIME MOVIE COLOR

TOTAL LOAD 47.3 MB

TO SUMMARIZE:

$D_1 = 0.280$ MB/S

$D_2 = 10.4$ MB/S

$D_3 = 1.7$ MB/S

$D_4 = 47.3$ MB/S

FIGURE 3.4 (B)

If 8 bytes are transferred every time, the message size equals $\frac{8 \text{ bytes}}{2} + 2 = 6$ frames, and the transfer time is 2.33 microseconds, giving a maximum data transfer rate equaling $\frac{8 \text{ data bytes/message}}{2.33 \text{ microseconds/message}} = 3.4 \text{ Megabytes/sec.}$

The maximum data transfer rates for longer messages are similarly calculated, and the results are summarized in Figure 3.5. It is readily observed that the maximum bandwidth of the "Q" protocol ranges from 0.75 Megabytes/second. 6.0 Megabytes/second depending on the message size.

3.3.2 Pended

Here, it takes 50 nanoseconds to transfer a message frame four bytes of address information. The remaining 2 bytes of the first frames, and all four bytes of the second and all subsequent frames, carry data (in block transfer mode).

If a message consists of one data byte only, only one message frame is necessary. The transfer time being 50 nanoseconds, the maximum data transfer rate is 20 Megabytes/second.

If, however, the message is comprised of eight databytes, three message frames are necessary. The transfer time is now $3 \times 50 \text{ nanoseconds} = 150 \text{ nanoseconds}$, giving a maximum data transfer rate equaling

$$\frac{8 \text{ databytes/message}}{150 \text{ nanoseconds/message}} = 53.3 \text{ Megabytes/second}$$

With similar calculations for longer messages, one obtains the results summarized in Figure 3.6. The Pended bus architecture permits a maximum data transfer rate varying between 20 Megabytes/second and 80 Megabytes/second depending on the message size.

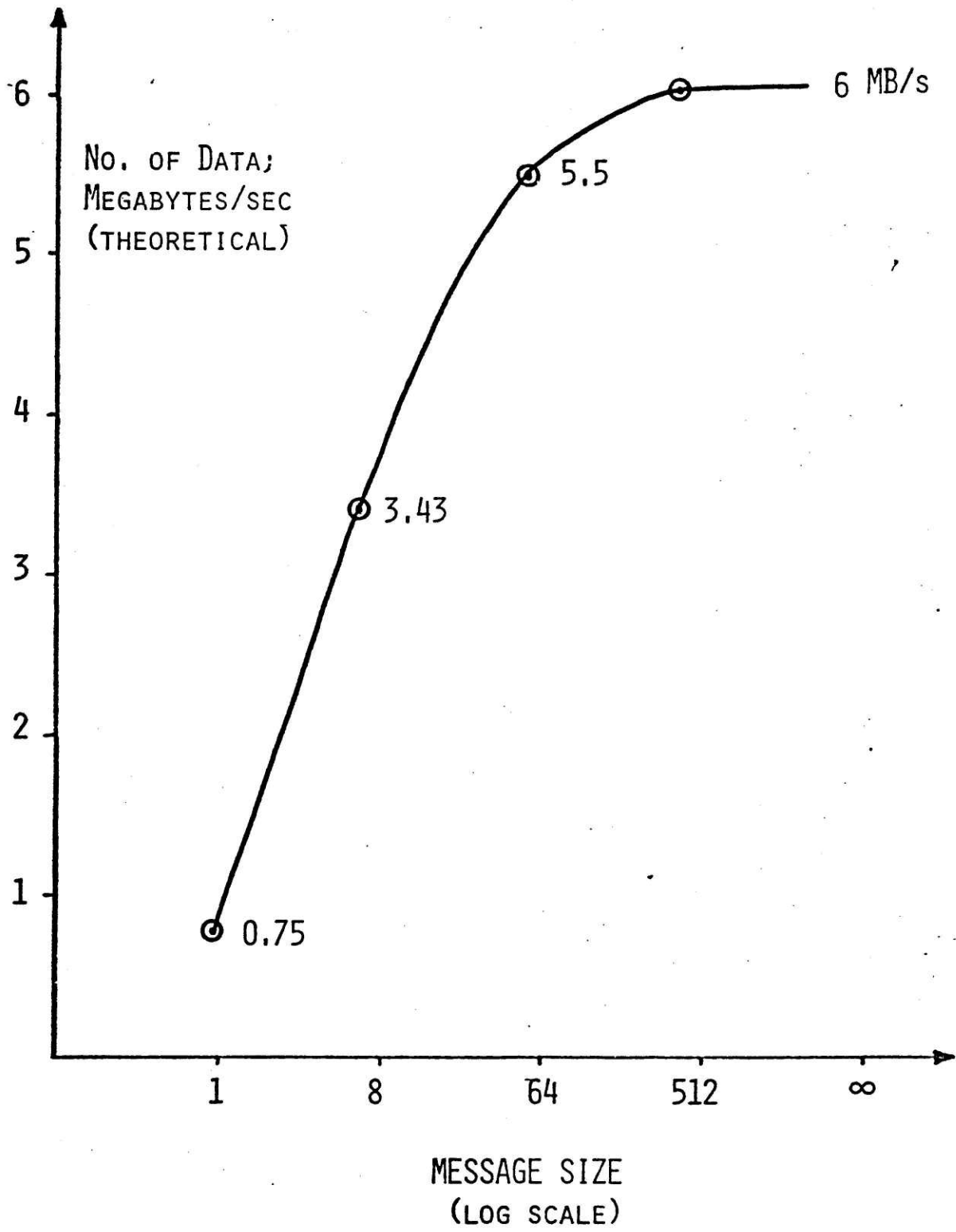

"Q"

FIGURE 3.5

No. OF DATA
BYTES/SEC.
(THEORETICAL)

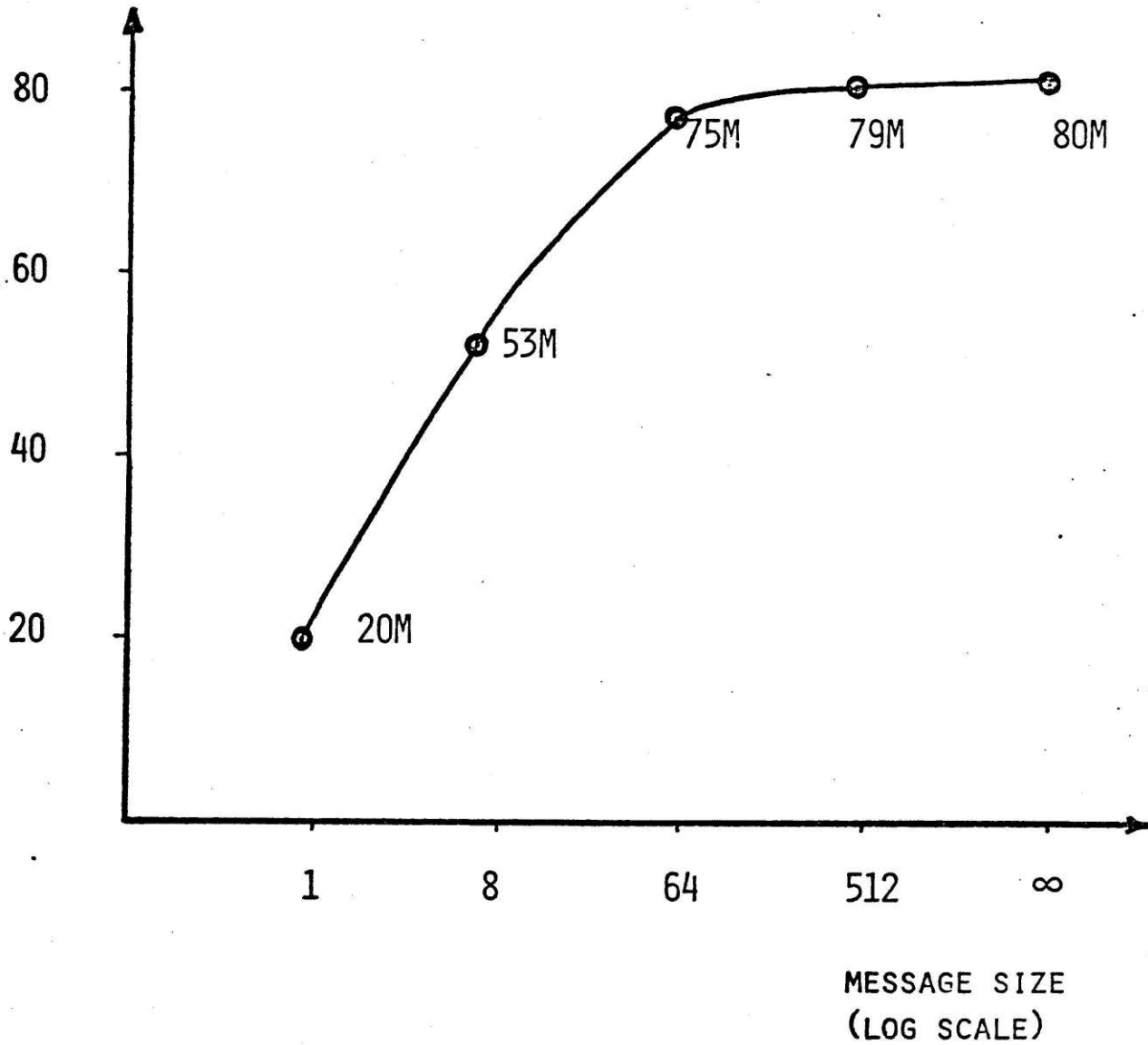

PENDED

FIGURE 3.6

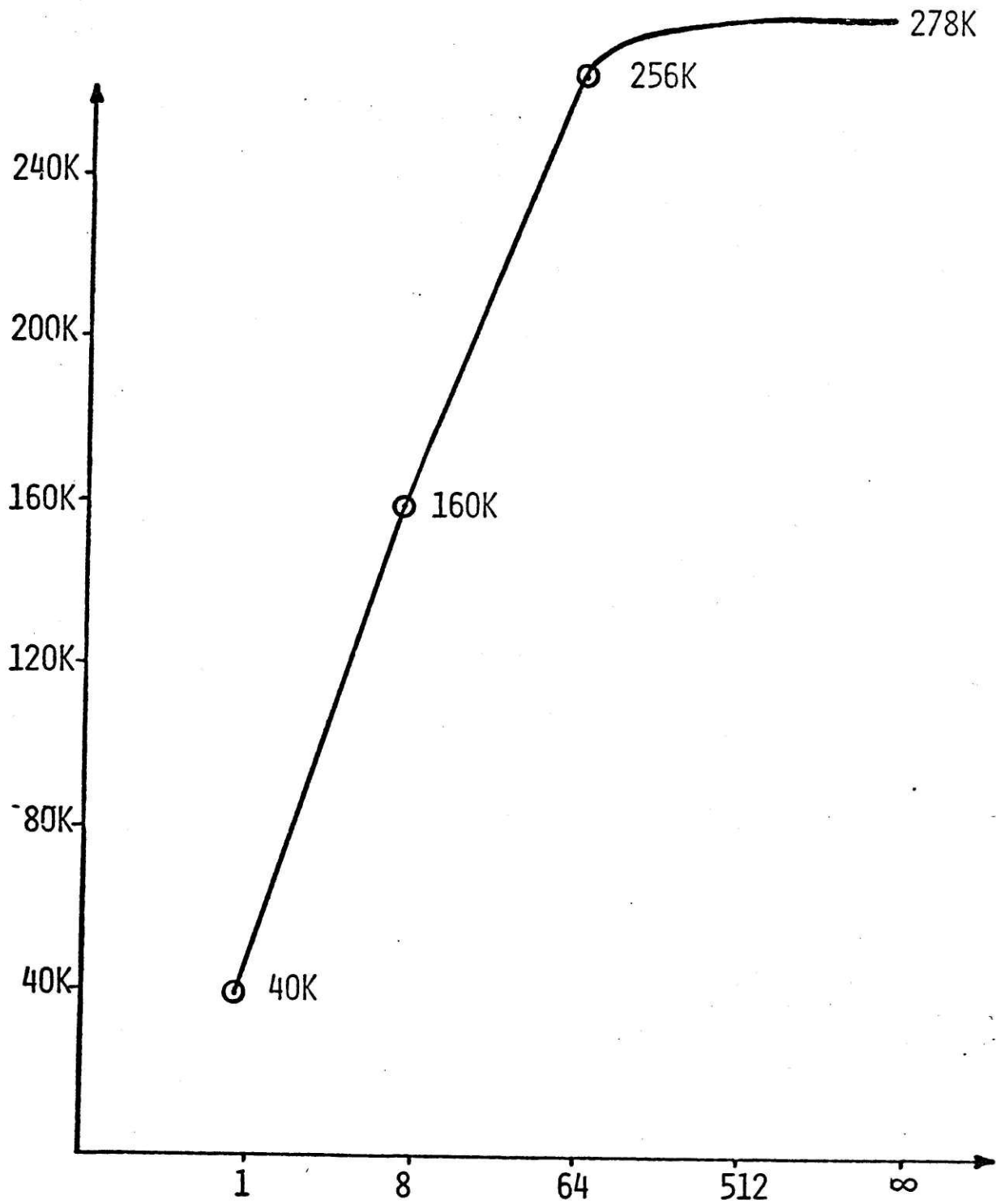

MESSAGE SIZE
(LOG SCALE)

FIGURE 3.7 SDLC

3.4 SUMMARY

In Section 3.2, the total communication loads for each of the four applications were calculated to be as follows:

Datapoint 1	=	0.28 MB/sec
Datapoint 2	=	10.7 MB/sec
Datapoint 3	=	1.7 MB/sec
Datapoint 4	=	47.3 MB/sec

In Section 3.3, the maximum capacities of the three bus architectures was shown to be as follows:

"Q"	=	6 MB/sec
PENDED	=	80 MB/sec
SDLC	=	0.278 MB/sec

Thus, in the "best" case, "Q" can accommodate datapoints 1 and 3 only, and SDLC is incapable of handling any of these applications. In the next chapter, the impact of contention is studied using IMMPS, and expected values of response times obtained.

4.1 Introduction

Response time is the sum of service time and the wait time. As message size increases, the service time increases proportionately. However, for the same data rate, there are now fewer messages, and a corresponding decrease in the probability that two messages will arrive simultaneously or almost simultaneously. This decreases the wait time. Thus, the overall response time reflects two conflicting trends, and it is advantageous to identify the minima in the curve; this point gives "best response time", and a realistic throughput rate.

In this section, IMMPS is used to calculate the response time.

4.2 "Q"

We assume an M/C/1 model, i.e., an exponential distribution of the message arrival rates, and a constant service time, with a single central server. The analysis is made for different message sizes (databytes per message = 1, 8, 64 and 512). Further, the impact of increasing the bus speed by factors of 10 and 100 respectively, is evaluated for the same message sizes. The increase in the bus speed can be due to one or both of the following reasons:

- (a) Using a faster technology for implementing the bus structure;
- (b) Using multiple (but identical) "Q" buses to interconnect all the elements.

In case (b), one must realize that such multiple buses require more buffer areas in all elements; furthermore, the housekeeping overhead for splitting the message for transmission purposes, and for the subsequent message recreating (or concatenation) exercise, will be enormous.

The results for the four datapoints are contained in Tables 4.1 and 4.2.; these are summarized in Figure 4.1. It is seen that the present "Q" speeds permit direct implementation for datapoint 1, and possibly for 3. The other datapoints dictate a modification of the "present" "Q"

RESPONSE TIME (μ s)

"Q"

	BUS 1	SPEED 10 \rightarrow	FACTOR 100
1	1.725 (∞)	0.136 (∞)	0.01332 (0.01436)
8	2.433 (∞)	0.234 (0.284)	0.024 (0.025)
64	11.979 (∞)	1.169 (1.304)	0.116 (0.117)
512	88.157 (∞)	8.62 (9.523)	0.86 (0.87)

\downarrow
BLOCK
SIZE

WITHOUT () = DATAPOINT 1
WITH () = DATAPOINT 2

TABLE 4.1

TABLE 4.2

RESPONSE TIME (μ s)

	BUS	"Q"	
		SPEED \rightarrow	FACTOR
	1	10	100
 BLOCK SIZE	1	0.152	0.014
	(∞)	(∞)	(0.025)
	8	0.238	0.023
	(∞)	(∞)	(0.025)
	64	1.184	0.1168
	(∞)	(5.089)	(0.112)
	512	8.73	0.86
	(∞)	(25.6)	(0.8)

WITHOUT () = DATAPOINT 3

WITH () = DATAPOINT 4

FIGURE 4.1

RESPONSE
TIME (μ S)
LOG SCALE

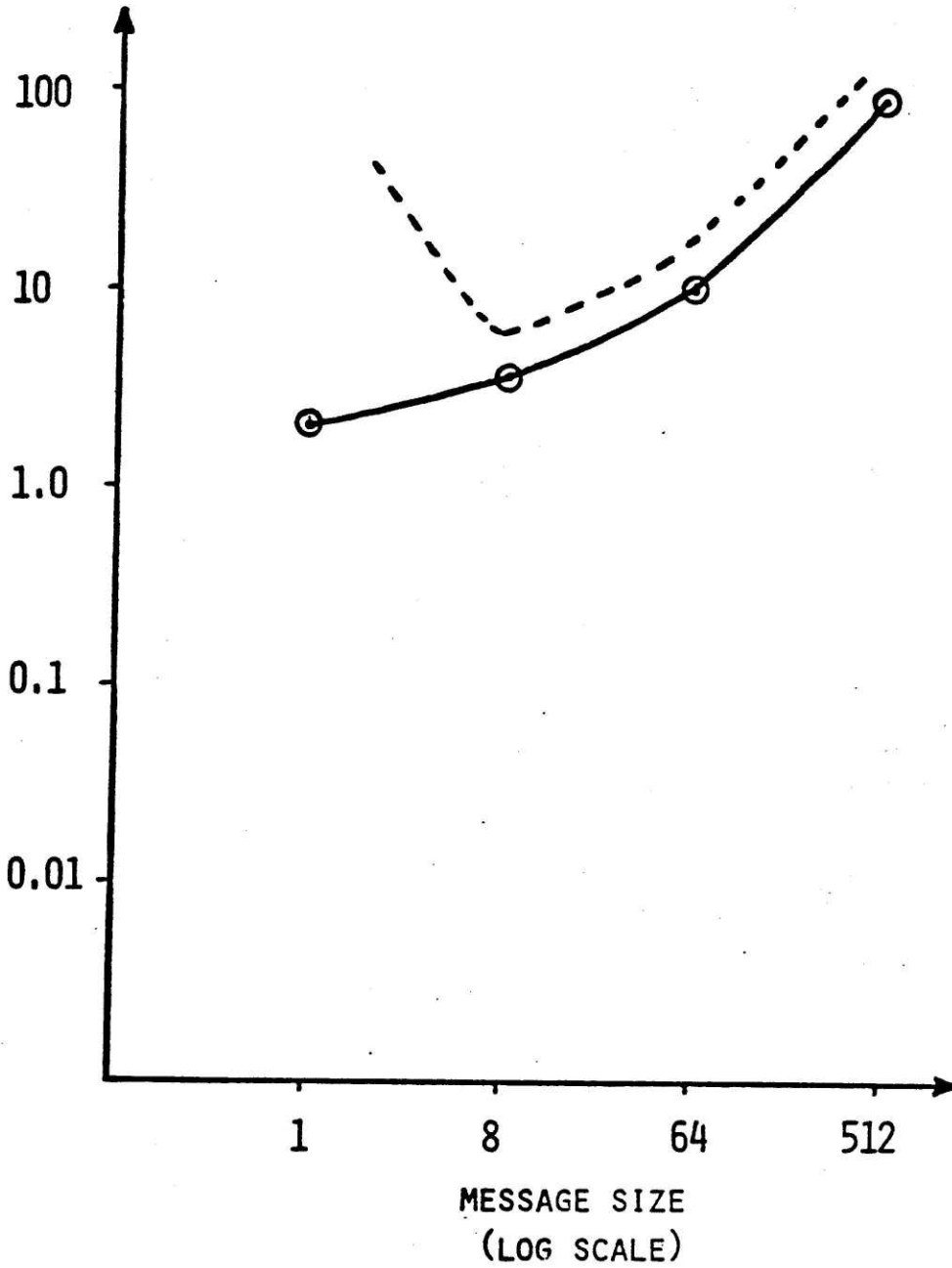

DATAPoint 1

2 & 4 (∞)

3 (DOTTED LINE)

"0"

4.3 Pended

The Pended bus architecture described in (5) is also modeled for various message sizes (1, 8, 64 and 512 data bytes per message), with bus speed factors of 1, 10 and 100, all under M/C/1 conditions. The results for the four datapoints are shown in Tables 4.3, 4.4 and 4.5; the graphical summary is contained in Figure 4.2. It is seen that the Pended protocol can cope with all the different data loads, except that a real time movie isn't feasible with a message size of 1 byte/frame.

4.4 SDLC

SDLC has several options, namely Point to Point, Loop and Multipoint configurations (31). In point to point, each processing element is arranged as shown in Figure 4.3 for datapoint 1.

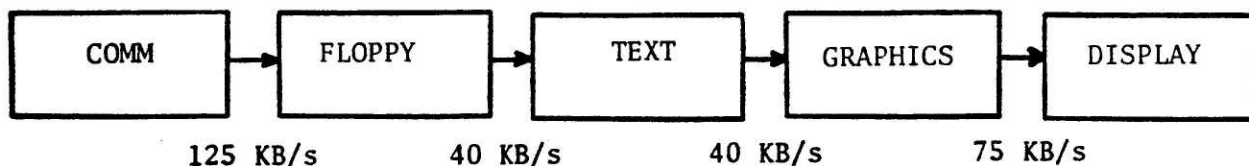

Figure 4.3: SDLC Point to Point

In a general case with 'n' processing elements, and each PE directly connected to every other PE, 'n x n' linkages will be necessary. As value of n increases, this option becomes increasingly unattractive, from the cost viewpoint.

The Loop is constrained by the limitation that in order to communicate with another secondary PE, a secondary PE must first transfer the entire message to a primary, and then another message is transmitted to the (destination) PE.

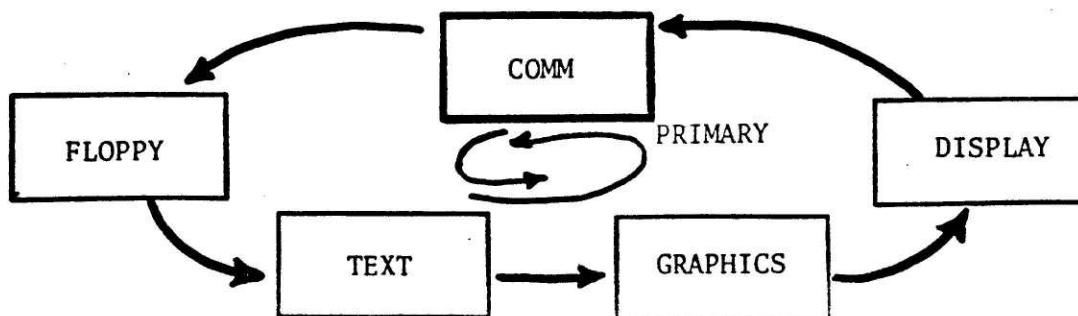

Figure 4.4: SDLC Loop

TABLE 4.3

RESPONSE TIME (μ S)

PENDED: DATAPOINT 1

	BUS	<u>SPEED</u> →	FACTOR
	1	10	100
1	0.05	0.005	0.0005
8	0.150	0.015	0.0015
64	0.852	0.085	0.0085
512	6.462	0.646	0.0645

↓
BLOCK
SIZE

RESPONSE TIME (μ s)
PENDED: DATAPOINT 2

	BUS	<u>SPEED</u> 	FACTOR
	1	10	100
1	0.075	0.006	0.0005
8	0.168	0.016	0.0015
64	0.919	0.0856	0.0085
512	6.943	0.649	0.0645

 BLOCK SIZE

TABLE 4.5

RESPONSE TIME (μ s)
 PENDED

	BUS 1	<u>SPEED</u> 10	FACTOR 100
1	0.052 (∞)	0.005 (0.057)	0.0005 (0.00051)
8	0.152 (0.761)	0.015 (0.0157)	0.0015 (0.0015)
64	0.860 (1.576)	0.085 (0.088)	0.0085 (0.0085)
512	6.521 (11.255)	0.647 (0.665)	0.0645 (0.0647)

↓
 BLOCK
 SIZE

WITHOUT () = DATAPOINT 3

WITH () = DATAPOINT 4

FIGURE 4.2

RESPONSE TIME (US)

LOG SCALE

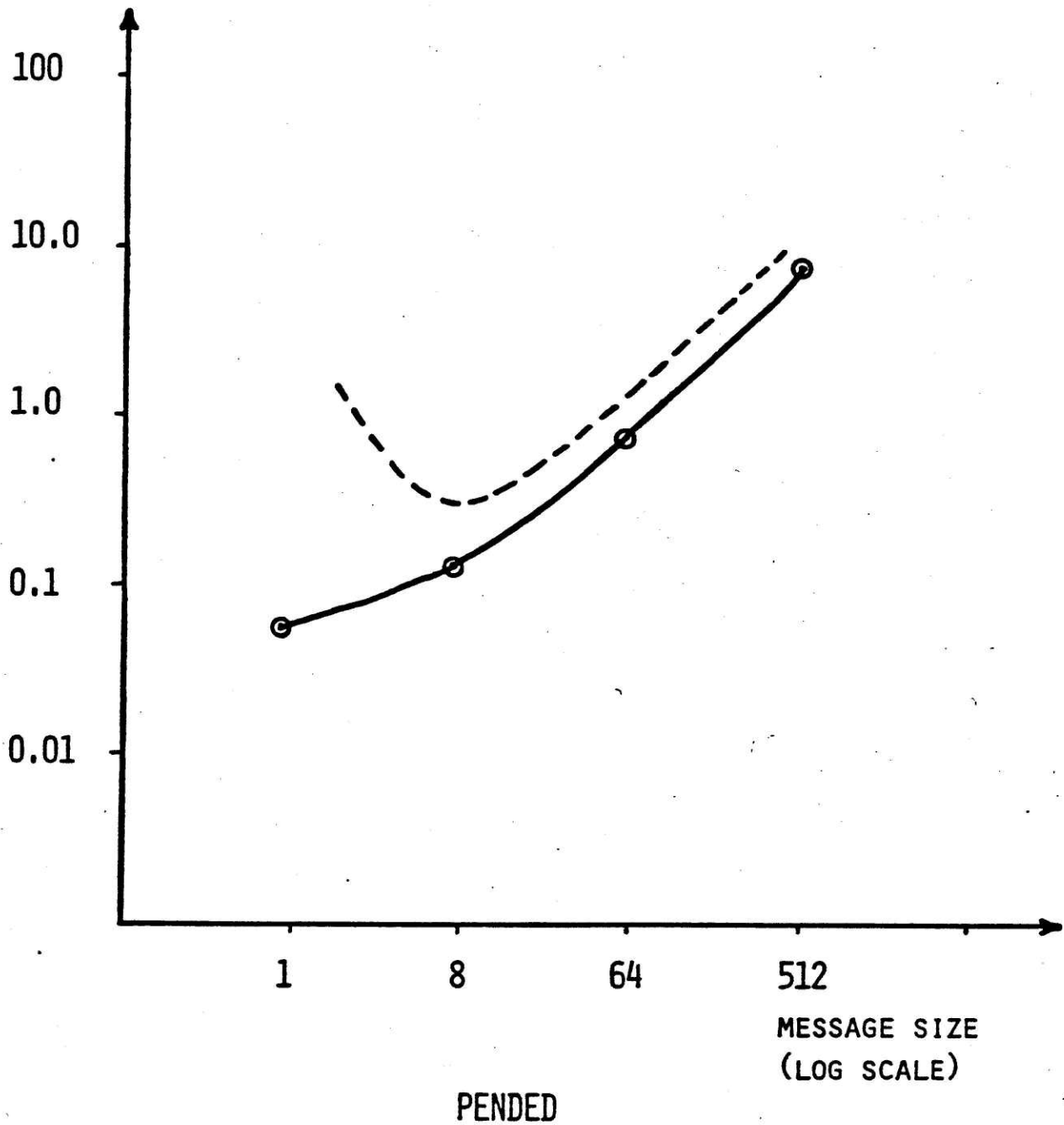
MESSAGE SIZE
(LOG SCALE)

PENDED

DATAPOINT 1

2 AND 3 ALMOST COINCIDE WITH 1

4 (AS DOTTED LINE)

TABLE 4.6

RESPONSE TIME (μ s)

SDLC

	BUS	SPEED \rightarrow	FACTOR
	1	10	100
1	∞	5.733	0.264
	(∞)	(3.147)	(0.259)
8	∞	5.654	0.514
	(146)	(5.27)	(0.511)
64	∞	27.13	12.564
	(443)	(26.07)	(2.556)
512	∞	212.499	20.112

BLOCK
SIZE

\uparrow No. OF BYTES OF INFORMATION
 \downarrow No. OF MESSAGES; RESPONSE TIME FOR EVEN THE
 LONGER MESSAGE \downarrow .

WITHOUT () = MULTIPOINT
 WITH () = POINT TO POINT

TABLE 4.7

RESPONSE TIME (μ s)

SDLC

	BUS	SPEED \rightarrow		FACTOR
		1	10	
1	∞	∞	∞	∞
	(∞)	(∞)	(∞)	(0.351)
8	∞	∞	∞	1.029
	(∞)	(∞)	(∞)	(0.540)
64	∞	∞	∞	3.471
	(∞)	(∞)	(∞)	(2.643)
512	∞	∞	∞	26.981
	(∞)	(∞)	(∞)	(20.714)

\downarrow
BLOCK
SIZE

WITHOUT () = DATAPOINT 2

WITH () = DATAPOINT 3

RESPONSE TIME FOR DATAPOINT 4 IS ∞ IN ALL CASES.

FIGURE 4.5

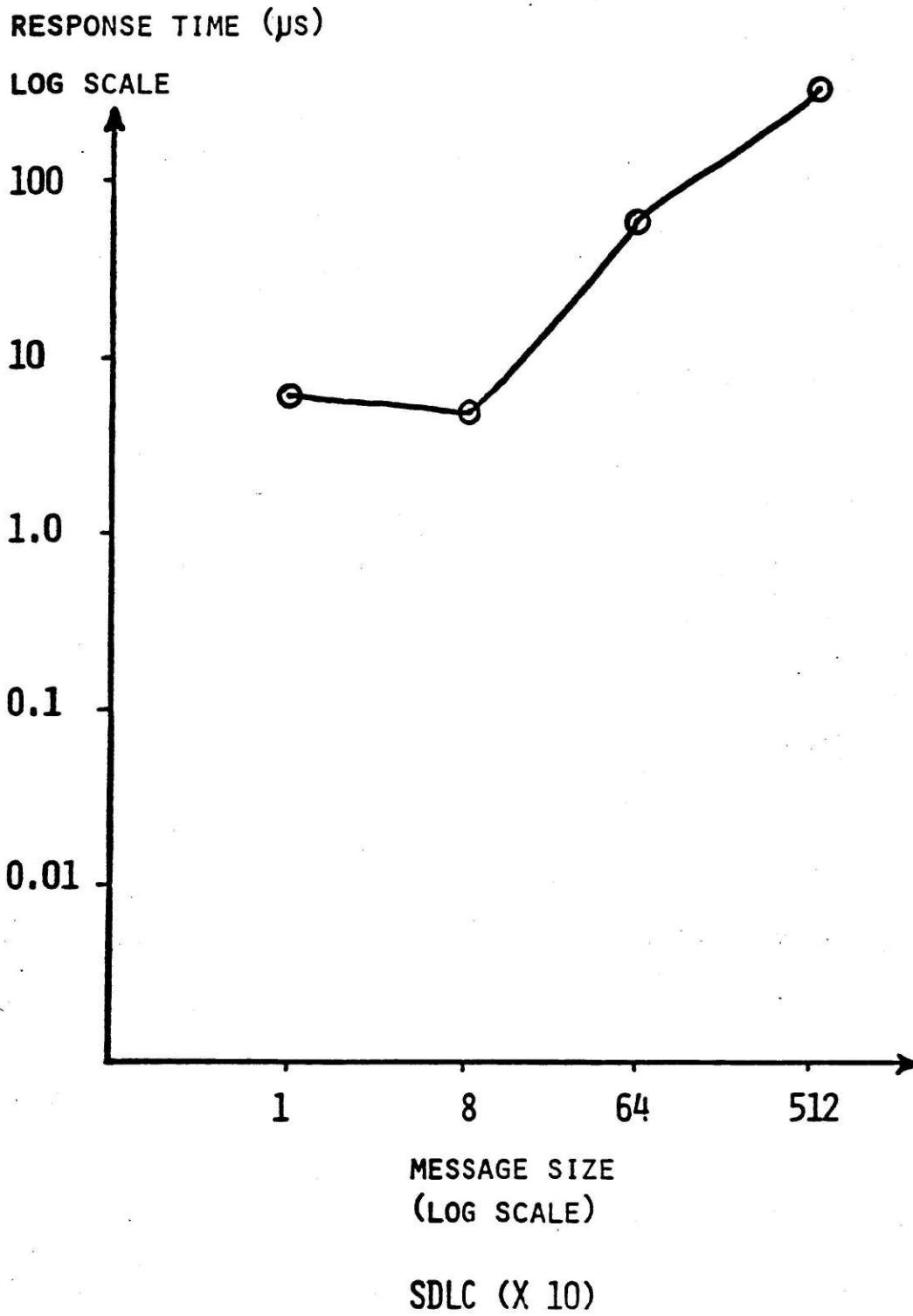

DATAPoint 1.
2,3,4 (∞)

Further, none of the links can be full duplex. Thus the 40 KB of data load between TEXT and GRAPHICS results in 40 KB of load from TEXT to COMM and another 40 KB from COMM to GRAPHICS. In all, it represents an average load of more than 40 KB for each link in the loop. The aggregate load of 280 KB/sec thus reflects almost 340 IB/sec over the link between DISPLAY and COMM. On the whole, this SDLC configuration results in large overheads, and hence large response times.

The multipoint configuration with full duplex links has been considered as it gives "best" response times. The same methodology and datapoints were used, and the results are contained in Tables .6 and .7. It is seen that SDLC, in the present form, is unable to handle the individual loads of any of the four datapoints at any message size. A bus speed factor improvement of 10 (either by increasing circuit speed, or by using 10 parallel SDLC links) makes some configurations feasible, and the results are summarized in Figure .5. Thus, if SDLC is to be used for supporting multimicroprocessor systems; it must either be speeded up, or a number of parallel SDLC links used; in the latter case, the inherent overhead must be taken into account.

4.5 CONCLUSION

The data presented in the preceding section can be summarized as shown below:

BUS STRUCTURE	Datapoint 1	Datapoint 2	Datapoint 3	Datapoint 4
"Q"	Feasible	Not Feasible	Feasible	Not Feasible
PENDED	Feasible	Feasible	Feasible	Feasible
SDLC	Not Feasible	Not Feasible	Not Feasible	Not Feasible

The above matrix illustrates that drastic modifications in SDLC speeds and/or protocols will be necessary in order to adapt it for multimicroprocessor applications. The "Q" protocol is currently suitable for a limited set of applications. The PENDED bus protocol is most suitable for the multimicroprocessor job environment.

CHAPTER FIVE
VALIDATION OF IMMPS

5.1 INTRODUCTION

In Chapter 2, the IMMPS analytic model was described; operating details are summarized in the appendix to this thesis. This model was used to derive the results in the preceding chapter. In the ideal case, one would have desired to cross-check the results using actual hardware and software. But since all the applications outlined are future projections, and the "Q" and PENDED bus architectures are still being implemented, one is compelled to look for alternative methods for model validation.

IMMPS is based on queueing theory, and the program implicitly uses closed form analytic expressions derived from the concepts of work flow and steady state considerations. Unfortunately, queueing theory provides results only for systems with static message arrival rates and service times. No doubt for these simple cases, it provides accurate results with little effort. But some inherent assumptions of queueing theory are not exactly valid, in particular, the assumption about infinite queue capacities. However, if physical queue capacities are more than 10 times the value of expected queue length, the queue capacity can be assumed to be infinitely long for all practical purposes. In Chapter 2, this approximation error was shown to be negligible; further, the error could be made as small as desired.

But to a critical observer, more direct evidence is required to completely validate the queuing model. An excellent analysis of these issues is contained in (32).

Fortunately, Abdel-Hamid (19) has developed simulation models for bus architectures. These simulation models, programmed in GPSS, have been used to verify the results obtained with IMMPS. Since the GPSS models assume finite queue capacities, it is possible to evaluate the true impact of assumptions made in IMMPS. (It would be relevant to point out, however, that a simulation run for a few milliseconds of real time costs more than 10,000 times as much as the execution of an equivalent analytic model in terms of computer time. Thus, some restraint in the domain of simulation runs became essential.)

5.2 RESULTS FROM THE TWO MODELS

For "Q" bus architecture, and datapoints 1, 2 and 3, the results are summarized in Tables 5.1, 5.2 and 5.3 respectively. The results for PENDED are contained in Tables 5.4, 5.5 and 5.6 (21).

Table 5.1 : "Q" : DATAPOINT

Serial No.	Bytes of Info. per Message	Bus Speed (ns)	Average response time by GPSS model (ns)	Average response time by IMMPS model (ns)	% difference from GPSS model
1	1	330	1770	1725	- 2.5
2	1	33	135	136	+ 0.7
3	1	3.3	13	13	0.0
4	8	330	2401	2433	+ 1.3
5	8	33	231	234	+ 1.3
6	8	3.3	24	24	0.0
7	64	330	11849	11979	+ 1.1
8	64	33	1157	1169	+ 1.0
9	64	3.3	115	116	+ 0.9

Table 5.2 : "Q" : DATAPOINT 2

Serial No.	Bytes of Info. per Message	Bus Speed (ns)	Average response time by GPSS model (ns)	Average response time by IMMPS model (ns)	% difference from GPSS model
1	1	330	∞	∞	0.0
2	1	33	∞	∞	0.0
3	1	3.3	14.0	13.3	- 1.0
4	8	330	∞	∞	0.0
5	8	33	283	284	+ 0.4
6	8	3.3	25	25	0.0
7	64	330	∞	∞	0.0
8	64	33	1296	1304	+ 0.7
9	64	3.3	116	116	0.0

Table 5.3: "Q" : DATAPOINT 3

Serial No.	Bytes of Info. per Message	Bus Speed (ns)	Average response time by GPSS model (ns)	Average response time by IMMPS model (ns)	% difference from GPSS model
1	1	330			0.0
2	1	33	149	152	+ 2.0
3	1	3.3	14	16	0.0
4	8	330	3399	3435	+ 1.0
5	8	33	237	238	+ 0.4
6	8	3.3	23	23	0.0
7	64	330	14229	14290	+ 0.5
8	64	33	1176	1184	+ 0.8
9	64	3.3	116	117	+ 1.0

Serial No.	Bytes of Info. per Message	Bus Speed (ns)	Average response time by GPSS model (ns)	Average response time by IMMPS model (ns)	% difference from GPSS model
1	1	330	50	50	0.0
2	1	33	5	5	0.0
3	1	3.3	0.5	0.5	0.0
4	8	330	150	150	0.0
5	8	33	15	15	0.0
6	8	3.3	1.5	1.5	0.0
7	64	330	851	852	+ 0.1
8	64	33	85	85	0.0
9	64	3.3	8.5	8.5	0.0

Table 5.4: PENDED: DATAPOINT 1

Table 5.5: PENED: DATAPOINT 2

Serial No.	Bytes of Info. per Message	Bus Speed (ns)	Average response time by GPSS model (ns)	Average response time by IMMPS model (ns)	% difference from GPSS model
1	1	330	72	75	+ 4.0
2	1	33	5.9	6.0	+ 1.7
3	1	3.3	0.5	0.5	0.0
4	8	330	159	168	+ 6.0
5	8	33	15.4	16.0	+ 4.0
6	8	3.3	1.5	1.5	0.0
7	64	330	899	919	+ 2.2
8	64	33	89	85.6	- 3.6
9	64	3.3	8.5	8.5	0.0

Table 5.6: PENED: DATAPOINT 3

Serial No.	Bytes of Info. per Message	Bus Speed (ns)	Average response time by GPSS model (ns)	Average response time by IMMPS model (ns)	% difference from GPSS model
1	1	330	52.3	52	- 0.6
2	1	33	5	5	0.0
3	1	3.3	0.5	0.5	0.0
4	8	330	152.3	152	- 0.2
5	8	33	15	15	0.0
6	8	3.3	1.5	1.5	0.0
7	64	330	879	860	- 2.4
8	64	33	86	85	- 1.2
9	64	3.3	8.5	8.5	0.0

In generating the above data, an M/C/1 model is assumed throughout. For simple WRITE operations, the bus service time is in fact a constant quantity dictated by hardware. On the other hand, for m-messages, it would be more appropriate to assume an M/M/1 model. As regards the arrival rates, it is difficult to prove that they are truly random. But it has been shown in (33) that when large numbers of sources are independently generating messages, then irrespective of the actual distribution of the individual message trains, the aggregate message train does in fact tend towards a Poisson distribution. In our case, the messages will emanate from the different microprocessors, and hence the bus will actually see a Poisson distribution of inputs.

5.3 ANALYSIS OF RESULTS

In all, there are 54 sets of observations summarised in Section 5.2. Of these, 27 sets have identical values for IMMPS and GPSS results. This implies that for these 27 sets, the differential was of a lower magnitude than the least count of that particular observation. This shows that the simulation runs were conducted over a "long period of real time," so that the aggregate period represented balanced statistics.

Of the other 27 observations, the break-up is as follows:

-∞	to	-5%	=	0	observations
-5	to	-1%	=	5	observations
-1	to	0	=	3	observations
0	to	+1	=	11	observations
+1	to	+5	=	8	observations
more than		+5	=	1	observations

The above distribution is slightly biased in favour of positive differentials. This implies that the analytic model gave response times slightly longer than the simulation model results.

After considerable exploration, it was discovered that the analytic model uses a 1 microsecond time for the transmission of a 3 frame GALAXY message whereas the simulation model simulates on a frame by frame basis, each frame taking 330 nanoseconds and 3 frames therefore taking 990 nanoseconds. This implies that the basic service time in IMMPS model was about $10/990 = 0.01$ or 1% higher than the corresponding service time in GALAXY model. The overall bias in the results is also of the same order of magnitude.

Finally, it must be emphasized that a data size of 54 observations is small by statistical measures, and in such a case, the sample mean and the population mean will differ by a few percentage points. On the whole, the results fall within these limits.

Minor differences between analytic and simulation models can further be explained as inherent in the modeling process itself.

Let us consider the analytic and simulation results for a very simple experiment, namely tossing a coin. If the coin is unbiased, the analytic model states that the number of heads (also equal to the number of tails) is exactly one half the number of times the coin was tossed. The probability of getting heads is irrespective of the number of tosses. A simulation run with only one toss will either yield a head ($p_H = 1.0$) or a tail ($p_H = 0.0$). If the simulations are repeated infinite numbers of times, then only $p_H = 0.5$.

A typical simulation run is depicted in Figure 5.1. One notices in this figure that as the number of simulated tosses increases, the function f_H (number of heads divided by number or tries) does tend towards 0.5. For a finite number of tosses, there is, however, a finite difference between f_H and 0.5, and this difference has an equal probability of being positive or negative. Thus, when any simulation run is compared with its analytical equivalent (that implicitly assumes an infinite number of simulations), some differentials must be expected.

Figure 5.1: Coin Tossing Experiment

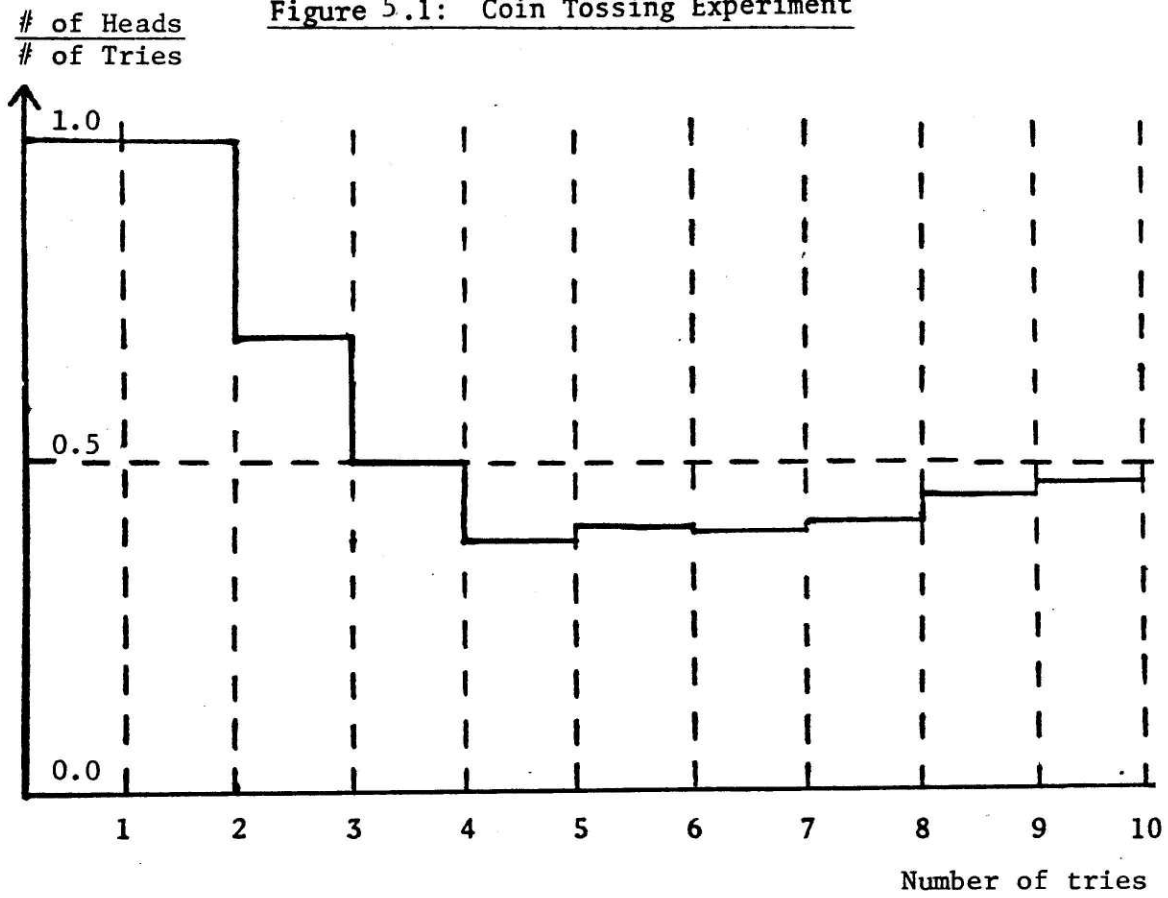

5.4 Conclusion

In this chapter, the results obtained through analytical and simulation methods have been presented, and an effort made to summarize the similarities and to explain the differences. The two methods have been used for evaluating the PENDED and GALAXY protocols over a wide spectrum of message sizes and sensitivity factors.

In order to obtain closed form solutions, the analytic model uses queueing theory implicitly making several assumptions. In the absence of these assumptions, queueing theory can be used only for very simple configurations, and these trivial cases are unlikely to be implemented using multi-microprocessors of tomorrow. On the other hand, for larger and practical configurations, one is forced to make the assumptions in order to obtain closed form solutions.

The simulation model is a step closer to the realities of the world. Here, one can map actual physical conditions; for example, the finiteness of queue capacities. This report examines the efficacy of the analytic model as compared to the simulation model in order to verify the impact of the implicit assumptions.

In this report, it has been seen that the results obtained through the two methods are identical within statistical tolerances. The enormous overhead involved in simulation runs make it suitable for rare occasions. Hence, for a first pass analysis, the analytic results are generally suitable.

CHAPTER SIX

CONCLUSION

6.1 PERSPECTIVE

In Chapter 1, it was emphasized that the overall throughput of multimicroprocessor systems is directly linked to the bandwidth of the interprocessor channels. As more complex and faster microprocessor/memory chips become technologically feasible, the criterion of optimal overall performance of multimicroprocessor configurations dictates the investigation and identification of new system architectures that support higher data transfer rates. This is achieved by faster circuits, increased number of message paths and/or by protocols that have lower overheads.

Chapter 2 described the Interactive Multimicroprocessor Performance System (IMMPS) and the facilities it provides to assist in the design and evaluation of alternative bus structures and for sensitivity analyses. The different bus architectures and some likely application areas were outlined in Chapter 3. In Chapter 4, our attention focused on the possibility of using the alternative bus structures in future multimicroprocessor systems. These results are discussed and cross-checked with outputs from simulation models in Chapter 5.

6.2 THE FUTURE!

In Chapter 1, the following phases in the development work were

indicated:

- (i) Analysis of microprocessors, and their suitability as basic elements in larger systems;
- (ii) Evaluation of existing interconnection protocols in order to identify the optimal bus architecture;
- (iii) Development of a distributed operating system;
- (iv) Final implementation.

It is seen that the PENDED protocol is most ideally suited to the communication needs of the multimicroprocessor systems of tomorrow. This analysis concludes Phase (ii) of the project, and IMMPS has been a valuable support tool throughout this phase.

The distributed operating system now deserves full attention. A preliminary analysis shows that IMMPS would be relevant for studying various possibilities in this area by treating parts of operating system as chains of m-messages. This work has already commenced, along with an attempt to minimize bus arbitration overhead. It is likely that as this work progresses, it may be desirable to enhance the capabilities of IMMPS through additional subroutines. In particular, IMMPS could be extended to analyze systems with multiple buses; this can be done easily by setting up multiple "central servers". Further, in analyzing memory management, decisions of swapping-in and swapping-out could be analyzed using an "extended IMMPS."

REFERENCES

1. Enslow, P.A., ed., Multiprocessors and Parallel Processing, Wiley, New York, 1974.
2. Hopkins, A.L., and T.B. Smith, "The architectural elements of a symmetric fault-tolerant multiprocessor", IEEE Trans. Comput., May 1975.
3. Evenchik, L.N., A High Bandwidth Synchronous Bus Multiprocessor, S.M. (EE & CS) Thesis, MIT, Sept. 1978.
4. Genson, I.A., Evaluation of Microprocessor Bus Requirements for Application to Multiprocessor Configurations,
5. Haagens, R.B., A Bus Structure for Multi-Microprocessing, S.M. Thesis, Dept. of EECS, MIT, 1978.
6. Holley, L.H., et al, "VM/370 asymmetric multiprocessing", IBM Systems Journal, Volume Eighteen, Number One, 1979.
7. Fuller, S.H., D.P. Siewiorek and R.J. Swan, "The design of a multi-micro-computer system," Third Annual Symposium on Computer Architecture, IEEE, 1976, p. 123.
8. Widdoes, L.C., "The Minerva multi-micro-processor," Third Annual Symposium on Computer Architecture, IEEE, 1976, p. 34-39.
9. Keen, P.G.W. and M. Scott Morton, Decision Support Systems, Addison Wesley, Reading, Mass., 1978.
10. Alter, S., Decision Support Systems, Addison Wesley, Reading, Mass., 1980.
11. Toong, H., Advanced Microprocessor Performance Measurement, CISR Technical Report #1, MIT., Dec. 1978.
12. Mergen, J-F., et al, Methodology for Software Measurement: Routine Level Measures, CISR Technical Report #2, MIT., Feb. 1979.
13. Smith, C., J-F. Mergen and H. Toong, Microprocessor Evaluation Methodology: Benchmark Results, CISR Technical Report #3, MIT, July 1979.
14. Mergen, J-F., C. Smith and H. Toong, Issues of Advanced Microprocessor Architecture, CISR Technical Report #4, MIT, July 1979.
15. Abdel-Hamid, T. et al, Architectural Comparisons: MC68000, Z8000, 8086, CISR Technical Report #5, MIT, April 1980.

16. Toong, H. and Amar Gupta, Interactive Multimicroprocessor Performance System, CISR Technical Report #6, MIT, April 1980
17. Gupta, Amar and H. Toong, Analysis of Galaxy Using IMMPS, CISR Technical Report #7, MIT, April 1980.
18. _____, Capacity Comparison of Various Interconnection Systems, CISR Technical Report #8 (under preparation), MIT, April 1980.
19. Abdel-Hamid, T., A GPSS Simulation Model of Galaxy, CISR Technical Report #9 (draft), MIT, March 1980.
20. Gupta, A., B. Chow and H. Toong, Evaluation of Multimicroprocessor Bus Architectures, CISR Technical Report #10 (draft), MIT, March 1980.
21. Gupta, A., T. Abdel-Hamid and H. Toong, Comparison of Analytic and Simulation Models, CISR Technical Report #11 (draft), MIT, April 1980.
22. _____, Multiprocessor Systems: An Annotated Bibliography, CISR Technical Report #12 (draft), MIT, April 1980.
23. _____, DOS-the Distributed Operating System for Multimicroprocessor Control, CISR Technical Report #13 (under preparation), MIT, April 1980.
24. Fung, F.T. and H.C. Torng, "On the Analysis of Memory Conflicts and Bus Contentions in a Multiple-Microprocessor System", IEEE Trans. on Computers, January 1979.
25. Buzen, J.P., "Computational algorithms for closed queueing networks with exponential servers", Comm. of ACM, 16, 9, September 1973.
26. Madnick, S.E., BEST/S write-up, Sloan School of Management, MIT, 1977.
27. Ferrari, D., Computer Systems Performance Evaluation, Prentice-Hall Inc., Englewood Cliffs, New Jersey, 1977.
28. Denning, P.J., and J.P. Buzen, "Operational Analysis of Queueing Network Models", ACM Computing Surveys, September 1978.
29. Kleinrock, L., Queueing Systems, Vols I and II, John Wiley & Sons, New York, 1975-76.
30. Kobayashi, H., Modeling and Analysis: An Introduction to Systems Performance Evaluation Methodology, Addison Wesley, Reading, Mass., 1978.
31. _____, IBM Synchronous Data Link Control, GA 27-3093-2, IBM, March 1979.

32. _____, COMPUTER, issue on Analytical Queueing Models, IEEE publication, April 1980.
33. Palm, C., "Intensitatsschwankungen im Fernsprechverkehr," Ericsson Technics, 44, 1-89 (1943) and Khinchin, A.J., Mathematical Models in the Theory of Queueing, Griffin, London, 1960 as quoted on p. 61. Vol. I of REF 29; also REF 28 and REF 30.
34. "The High Cost of Microprocessors", Lecture by Prof. H. Toong in the symposium on "How Microprocessors are Changing Product Design", MIT, April 16, 1980.
35. Posa, John G., and Bruce LeBoss, "Intel takes aim at the '80's," Electronics, February 28, 1980.