

Commercialization Potential of compositionally graded
Ge - Si_{1-x}Ge_x - Si substrates for solar applications

by

Johnathan Jian Ming Goh

Bachelor of Engineering (Electrical) (Honours)
National University of Singapore, 2005

SUBMITTED TO THE DEPARTMENT OF MATERIALS SCIENCE AND
ENGINEERING IN PARTIAL FULFILLMENT THE REQUIRMENTS FOR THE
DEGREE OF

MASTER OF ENGINEERING IN MATERIALS SCIENCE AND ENGINEERING
AT THE
MASSACHUSETTS INSTITUTE OF TECHNOLOGY

SEPTEMBER 2006

©2006 Johnathan Jian Ming Goh. All rights reserved.
The author hereby grants to MIT permission to reproduce
and to distribute publicly paper and electronic copies of this
thesis document in whole or in part in any medium now
known or hereafter created.

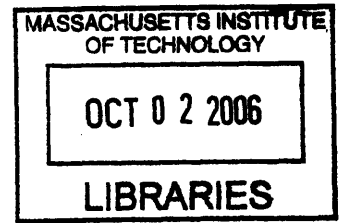

Signature of Author:

Handwritten signature of the author, Johnathan Jian Ming Goh.

Department of Materials Science and Engineering
July 27, 2006

Certified by:

Handwritten signature of Eugene A. Fitzgerald.

Eugene A. Fitzgerald
Thesis Supervisor

Merton C. Flemings-SMA Professor of Materials Science and Engineering

Accepted by:

Handwritten signature of Samuel M. Allen.

Samuel M. Allen
POSCO Professor of Physical Metallurgy
Chair, Departmental Committee for Graduate Students

ARCHIVES

**Commercialization Potential of compositionally graded
Ge – Si_{1-x}Ge_x – Si substrates for solar applications**

by

Johnathan Jian Ming Goh

**Submitted to the Department of Materials Science and
Engineering on July 27, 2006 in Partial Fulfillment of the
Requirements for the Degree of Master of Engineering in
Materials Science and Engineering**

Abstract

This project considers the potential of Ge – Si_{1-x}Ge_x – Si substrates for solar applications. The use of compositionally graded substrates to achieve heterointegration across different materials platforms such as Si, Ge and GaAs has proven successful and dual junction solar cells have been fabricated on such substrates. The potential for graded substrates in the solar market is discussed considering the current technology, market players and worldwide renewable energy policies. A cost model is also developed and analyzed in the course of writing to assess the feasibility of this commercial enterprise. The result of these analyses highlights the technical and commercial viability of graded substrates in the solar market.

Thesis Supervisor: Eugene A. Fitzgerald

Title:

Merton C. Flemings-SMA Professor of Materials Science and Engineering

Acknowledgements

I would like to take this opportunity to thank the following people for their contributions that have made this thesis possible:

Firstly, my Lord and Saviour, **Jesus Christ**, who created all things and without whom there will be nothing to research about. Thank you for your grace that is more than sufficient for me and for giving me the privilege of studying in such a wonderful institution as MIT. Truly words cannot express my heartfelt gratitude and praise.

Professor Eugene Fitzgerald, I thank you for the honor of being called your student. I am truly blessed by your leadership and example not only in the academic arena but also in the commercial world as well. I really appreciate the patience and guidance that you have afforded me through this thesis and your insights that make this work a success. Thank you for broadening my horizon and deepening my understanding.

Mom and Dad, I love you so much. Words fail when I think of how to best appreciate your efforts in raising me and providing for my education. I only hope that through my life, my words and my actions and even now through this thesis that I will make you proud.

My dearest brother **Daniel**, I love you very much too. I hope that even as God has provided me with this opportunity to be a student in MIT, and that He will use me as an encouragement to spur you on to be the best you can be.

I would like also to thank my university, **Massachusetts Institute of Technology (MIT)** and my department, **Department of Material Science and Engineering (DMSE)** for the wonderful opportunity to be called a student and for imparting to me a world of knowledge that I would otherwise have never known. I also would like to acknowledge the **Singapore – MIT Alliance (SMA)** and its faculty and staff who have graciously provided my fellowship, guidance and assistance in so many ways.

Last but not least, I would like to thank all my friends and church friends for your constant support and encouragement. The BS group, SSS, YAG, FLM, the leaders group and the girls, Jocelyn, Huiting, Ruth, Amanda, Erlina, Dorea and Sarah.

Solo Deo Gloria!

Contents

Thesis abstract	2
Acknowledgements	3
Contents page	4
Introduction	5
Technology description	6
Potential Target markets	8
The competition	9
Patent literature	10
Competing solar cell technology	14
Competing solar cell manufacturers	15
The worldwide market	17
Performance and cost analysis	19
Business strategy	22
Conclusion	24
References	25
Appendix 1 – Graded substrate processing conditions	27
Appendix 2 – Relevant compositionally graded substrate patents	29
Appendix 3 – Multijunction solar cell patents	31
Appendix 4 – Emcore patents	33
Appendix 5 – Spectrolab patents	35
Appendix 6 – Concentrator solar cell literature review	38
Appendix 7 – Sharp Corporation	41
Appendix 8 – Company classification	43
Appendix 9 – Japanese solar companies	44
Appendix 10 – China and Taiwanese solar companies	50
Appendix 11 – US solar companies	53
Appendix 12 – European solar companies	55
Appendix 13 – Emcore company review	61
Appendix 14 – Spectrolab company review	66
Appendix 15 – Japanese renewable energy policy	68
Appendix 16 – China renewable energy policy	72
Appendix 17 – US renewable energy policy press releases	74
Appendix 18 – The EPIA and European Union solar policies	77
Appendix 19 – Space solar market size estimation	82
Appendix 20 – Cost model details	83
Appendix 21 – Thesis presentation powerpoint slides	90

Introduction

Two main trends seen in the world of microelectronics today are that of heterointegration and an increasing focus on “green” technologies. The former is primarily the result of material limits to Moore’s Law which necessitates the integration of new materials into existing platforms; the latter being in line with global shifts towards environmentally friendly technologies, such as renewable sources of energy and lead-free solder just to name a few.

With Moore’s Law, the packing density of transistors on a microchip increases exponentially. A byproduct of this scaling is the proportionate increase in speed as a result of smaller device dimensions. However, scaling into the nanoscale regime results in the appearance of non-classical quantum mechanical phenomenon which sets some inherent device performance limits based on the existing materials set being used. Whilst a manufacturable solution is still being sought out for scaling to continue and Moore’s law to hold, the alternative paradigm proposed in heterointegration is the addition of new functionalities into the existing platform. Existing examples of such heterointegration taking place include the incorporation of RF processing onto Si and in the future even optical functionalities onto the same microchip.

The interest in green technologies was brought about on the other hand by the dwindling supplies of crude oil as underground reserves are increasingly used up. This supply decline coupled with the increasing demand for crude oil and the volatile middle east situation has been a strong driving force for energy diversification into other alternatives such as nuclear, hydroelectricity, wind and solar just to name a few.

These two large paradigms in technology development set the world stage upon which compositionally graded substrates is unveiled. In its infancy, heterointegration across materials systems platform involve the epitaxial growth of III-V materials on group IV materials, and riding the “green wave” has been identified as the way to go in terms of commercializing this technology. It is this straddling and at this confluence of ideas that the commercialization begins, and this poses unique challenges that arise not only from the materials front but also in navigating the complex marketplace in terms of carving a niche for profit making. It is the author’s hope that through this verbalization of ideas to take the avid reader through the process from research lab to marketplace and highlight the various challenges involved and techniques and/or strategies to overcome them.

This discussion begins by describing the compositionally graded substrate technology not only for what it is, but also critically assessing its strong points and limitations. This will set the stage then for what the intended commercialization route is. Down this path, the various markets around the globe are examined, including the key existing and established players in the field. Having thus looked the technology at hand, the market to play and the players to beat, the rest of the discussion will consider the strategy to be adopted.

The discussion closes after considering all these aspects with a return to the two key ideas introduced at the beginning – heterointegration and “green” technologies and considers the viabilities of these strategies in the long haul.

Technology description

Conventional semiconductor processing wisdom has been confined largely to the realm of silicon. Through decades of painstaking development in refining impure sand into single crystal silicon ingots and then into the microchips that are so prevalent today, countless millions have eked out a living specializing in a minute part of this process that has brought about a quality of life that will otherwise be quite unattainable. Today, hundreds of thousands of people worldwide are still laboring in this field, seeking to squeeze every last drop out of this silicon platform and to redefine existing limits of performance through the addition of elements all over the periodic table.

Germanium, the semiconductor on which the first transistor developed was based on, rapidly lost its preeminent position due to the overwhelming abundance of silicon in the earth's crust. Beyond availability, processing issues such as lack of a stable native oxide, poorer mechanical and thermal properties has largely confined this element to its proliferation in high speed analog devices, where overcoming these challenges are made necessary because of the high speeds required.

III-V compounds, the most famous of which being gallium arsenide, was slow in gaining acceptance initially because of processing issues. The lack of a stable native oxide, the volatility of the group V element, finding suitable impurity dopants, all these were issues of the past that kept these compounds away from mainstream logic devices, along with its prohibitive cost. It was only when these issues were overcome when III-V materials dominated the optical market because of its superior properties compared to silicon or germanium. Nevertheless, because silicon and germanium started off earlier, the tremendous inertia of the existing industrial machinery that has been put in place, coupled with the maturity of various platforms in their specific application areas makes it hard for any material to be dislodged and/or replaced entirely.

Heterointegration thus seeks not to displace each material from its existing application space, but rather to combine different materials together such that a single microchip will be able to possess different combinations of functionalities for novel applications. Because this is a materials problem, a materials answer must be found. Each material, be it silicon, germanium or gallium arsenide, comes with its own idiosyncrasies in lattice constant, coefficient of thermal expansion, as well as processing techniques to name a few. Therefore the challenge is to find a solution so that these materials can co-exist on a single platform and still retain its individual properties.

These different properties result in inherent problems when one material is directly grown on the other. To begin, in the case of GaAs, material incompatibilities, which include large lattice mismatch (~4.1%), large difference in thermal expansion coefficient (~110%), antiphase domains (APDs), and autodoping create difficulty for growing GaAs directly on Si. The high lattice mismatch creates misfit dislocations at the GaAs/Si interface and eventually results in threading dislocations at the GaAs surface. Furthermore, the large thermal-expansion difference results in tensile strain in the GaAs layer during substrate cooling, which may cause cracks and degradation in the optical properties of the GaAs layer.^[1]

Direct growth of GaAs on Ge is possible, given the small lattice mismatch ($\sim 0.08\%$) and almost no thermal expansion mismatch between these two materials. The main challenge is the occurrence of APDs at the GaAs/Ge interface. These are crystalline defects caused by difference in the crystal structure of GaAs (zinc blende) and Ge (diamond).^[2] Over the years, Ge (100) with 6° offcut towards (111) plane has been demonstrated by many research groups to eliminate APDs, either in metal-organic chemical-vapor deposition^{[3],[4]} (MOCVD) or molecular-beam epitaxy^[5] (MBE) growths.

The second part of this solution involves the transition from germanium to the silicon substrate. This is done in the gradual introduction of germanium in successive layers of increasing concentration. At first this strain is elastically accommodated, but past its critical thickness, thermodynamics dictate the formation of misfit dislocations to reduce this strain buildup. The grade is interrupted at the 50% Ge layer to perform a critical chemical mechanical polishing (CMP) step to remove the deepest “crosshatch” features that cause dislocation pinning and pileup formation, and thus promote efficient dislocation glide without unnecessary nucleation of new dislocations.^[6] The grading is completed at 92% with the deposition of a uniform Ge cap layer. The growth conditions are elaborated in Appendix 1.

Growth of the epitaxial Ge layer (~ 100 nm thick) was found to be critical to produce a smooth, chemically clean starting surface as verified by RHEED. Nucleation of GaAs directly on the Ge surface (without any epitaxial Ge growth) typically resulted in high defect densities due to the uncontrolled initial surface. The epitaxial Ge must then be annealed above 640°C for ~ 20 min. This anneal, coupled with the large 6° offcut, results in a double-stepped Ge surface as confirmed in-situ by RHEED which greatly suppresses APD formation.^[7]

The solution described above has several strong points. Firstly, all three important material systems can be found on the same substrate. Theoretically therefore, access to all three platforms and inter-platform functionalities are all achievable in this design. Secondly, the base substrate limiting the overall size of the wafer is that of silicon, which has always been the largest of all and currently stands at twelve inches or three hundred millimeters. Thirdly, because the base substrate is silicon, therefore germanium or gallium arsenide layers grown on this substrate will benefit from the increased mechanical strength of the silicon substrate.

The proposed design is suitable for solar cell applications with the following considerations to bear in mind. Firstly, a grading rate of 10% per micron gives a minimum increase in substrate thickness of ten microns from start to finish. This poses a problem for conventional CMOS technology because a ten micron via must be etched to expose the underlying silicon. Current developments have reduced the graded buffer thickness to about seven microns but this distance is still significant. For the fabrication of solar cells however the thickness of the graded buffer does not matter because contact formation can be still done on the backside of the silicon substrate.

Secondly the thermal expansion mismatch must be carefully controlled to minimize cracking or warping.^[8] During the final stages of the graded buffer growth, deposition is carried out at a lower temperature so that the resultant compressive stress compensates for the tensile strain that develops upon cooling down. This stress management complexity increases with the

deposition additional III-V layers above the graded buffer. Thirdly, if growth is properly done to eliminate APD formation, then the growth of gallium arsenide on germanium has been found to be as high quality as that of a pure gallium arsenide substrate. Therefore, solar cells grown on graded substrates will thus be of a comparable quality to those grown on commercially available germanium substrates.^[9]

Potential target markets

In looking at the technology presented above, the best foot forward in coming up with a marketable product would necessarily take full advantage of having the optical properties of III-V materials on a silicon platform. This would therefore narrow the search for a potential application space to either that of LEDs, solar cells and optical interconnects. For on-chip optical interconnects to be realized, lasers, waveguides and photodetector elements must be developed monolithically on the silicon platform. Such research requires time and effort, and is at a stage where lasing action has been demonstrated on graded substrates for as long as four hours.^[10] Whilst lasing lifetime is currently limited by dislocation density, further research and development and the eventual move from the laboratory into mass production has shown to reduce this to a level where perhaps reasonable lasing lifetimes can be achieved.

In order for graded substrates to enter the optical interconnect market; it must be of a large enough size to generate enough profit quickly. This is not the current situation although this may happen perhaps five years down the road. Also, there must be sufficient capital to further research to improve the quality of epitaxial layers grown on graded substrates and therefore a current market must be found and tapped on as the interim step before entering the optical interconnect market in the future.

Although the LED market utilizes the optical properties of III-V materials, the emphasis of this market is two-fold: high luminescence efficiency as well as low cost. The first is achieved in graded substrate technology but the problem of cost is exacerbated. Looking at the fabrication steps necessary for the preparation of graded substrates, the use of vacuum deposition equipment as well as chemical-mechanical polishing tools raises production costs substantially and thus a potential application in this market would be not as competitive compared to existing solutions. Other problems include the problem of introducing additional colors in LEDs because the technology is restricted to the bandgap of gallium arsenide, and LEDs do not require the increased mechanical strength afforded by the underlying silicon substrate which was noted as a potential asset of this technology. Therefore to enter this market, the main strategy is to ramp up graded substrate technology production to levels where it is cost-effective enough to compete with LEDs, and this can be achieved through entering another market and establishing graded substrate technology and production there and then utilizing those profits earned to penetrate into the LED market.

Given the global trend of moving towards environmentally friendly technology, the solar market is left as the market of choice for an initial product launch. The solar market however is also subdivided into several application subareas, namely on-grid residential photovoltaic, off-grid solar applications, space solar and the portable solar power market. Immediately, the

portable solar power market, which involves solar cells entering portable devices such as watches and calculators, is ruled out as an initial target market because like LEDs the high focus on cost places graded substrate technology at a significant disadvantage compared to existing solutions. Also ruled out is the off-grid solar applications market which involves uses such as billboard illumination and provision of electrical power in remote areas because the market size is small and there is no drive for higher efficiency in remote applications because space is not an issue.

Therefore by elimination, the two target markets that an initial product utilizing graded substrate technology should target are that of the on-grid residential photovoltaic (PV) market as well as the space solar market. In comparison to an entry into the LED or optical interconnect market which is by far more complicated, entering the solar market is easy. Furthermore, targeting a niche market or application like space solar takes full advantage of the benefits brought about by graded substrate technology. For the space solar market, the full benefits of improved mechanical strength at lower weight (and therefore lower payload cost), larger substrate area and lower production cost are capitalized on. Similarly, the residential PV market stands to gain from the potential substantial increase in conversion efficiency albeit at a higher initial cost. Also, these graded substrate solar cells have also been tested to ensure their performance maintains at maximum even through the toughest environments.^[11] Tests have even been carried out by utilizing graded substrate solar cells in space orbits and yet no form of performance degradation was observed

A proof of concept demonstration of a dual junction $\text{In}_{0.49}\text{Ga}_{0.51}\text{P}/\text{GaAs}$ solar cell has been fabricated on such graded substrates. These solar cells have an efficiency of 18.1% under the AM1.5-G spectrum, and various sizes of solar cells were fabricated, the largest being 4 cm^2 , showing the scalability of this approach. To prepare for the deposition of GaAs, a 30 nm thick layer of Ge is first deposited followed by a substrate anneal at 640°C . Next, ten periods of migration-enhanced epitaxy of GaAs at 350°C beginning with an As prelayer, and concludes with a $0.1\text{-}\mu\text{m}$ layer of GaAs grown at a rate of $0.1\text{ }\mu\text{m/h}$ and a substrate temperature of 500°C . This procedure suppresses antiphase domain (APD) formation and minimizes cross-diffusion, which allows the use of thin GaAs buffer layers of less than 200 nm.^[13] The p+/n polarity was chosen for these solar cells based on earlier results showing it to be much less susceptible to TDD-related carrier lifetime reduction and depletion region recombination issues than n+/p cells.^[14] A detailed description of the fabrication process can be found in reference 13.

The competition

Having examined the characteristics of graded substrate technology, the next step in the logical progression is to examine the possible alternative paths that one can take to arrive at the same heterointegration result. Clearly, there are several different alternative methodologies that have been explored that exist in the literature of today. Broadly speaking, these approaches fall into the broad heading of “competition” which, for purposes of discussion, is divided into three different areas, namely, competing graded substrate technology, competing solar cell technology and competing solar cell manufacturers.

Patent literature

The graded substrate technology presented previously is essentially the growth of germanium on silicon with an intermediate buffer layer in between that is lattice matched to both silicon on the bottom and germanium on top. Given the innumerable permutations of elements and compounds available in the periodic table, and in considering the famous bandgap versus lattice constant plot, it is not surprising that countless solutions may exist as to what material the intermediate buffer layer is made of. Examples of such alternatives that have been looked into are found in patent literature and various research journals. These examples can be sub-divided into several categories.

The first area covered in the patent space is where our graded substrate technology has staked its claims. Examples of such patents include:

7,041,170	Method of producing high quality relaxed silicon germanium layers
6,927,147	Coplanar integration of lattice-mismatched semiconductor with silicon via wafer bonding virtual substrates
6,921,914	Process for producing semiconductor article using graded epitaxial growth
6,876,010	Controlling threading dislocation densities in Ge on Si using graded GeSi layers and planarization
6,864,115	Low threading dislocation density relaxed mismatched epilayers without high temperature growth
6,039, 803	Utilization of miscut substrates to improve relaxed graded silicon-germanium and germanium layers on silicon

The value of these patents in the commercial arena cannot be understated. Several pieces of information affect the business viability of the graded substrate venture. Firstly, the idea of using a graded buffer to accomplish the goal of integrating one material on another is one approach to solving the heterointegration problem. Secondly, the exact process methodology required to achieve epitaxial layers of the desired quality is important information. Last but not least, techniques used to improve device performance must also be protected from unlicensed use. These patents are therefore useful to protect the intellectual property surrounding the graded substrate invention from competing companies that may profit otherwise. The summary abstracts of these patents are given in Appendix 2.

Other growth strategies for germanium on silicon are also found in patent literature. These include the use of LPCVD for growth as well as growing germanium directly on silicon. Examples of patents which fall into this category include:

5,326,716	Liquid phase epitaxial process for producing three-dimensional semiconductor structures by liquid phase epitaxy
5,397,736	Liquid epitaxial process for producing three-dimensional semiconductor structures
6,429,098	Process for obtaining a layer of single-crystal germanium or silicon on a substrate of single-crystal silicon or germanium, respectively, and multilayer products obtained

6,537,370 Process for obtaining a layer of single-crystal germanium on a substrate of single-crystal silicon, and products obtained

These patents do not inherently pose any challenge to the commercialization of graded substrate technology because of the process limitations that these growth techniques have. LPCVD being carried out at higher pressures than MOCVD or MBE results in the introduction of significant amounts of impurities in the graded substrates and thus the performance of wafers grown thus are inferior in comparison. MOCVD also has the advantage of higher throughput as compared to MBE whilst maintaining a high level of quality as compared to LPCVD. Direct growth of germanium on silicon results in the formation of 3D islands at large thicknesses values because the stress built up due to lattice mismatch is inelastically accommodated through the formation of dislocations. The resultant dislocation density is of the order of 10^7 cm^{-2} or higher, and thus unable to support minority carrier devices on silicon. Therefore, although these patents describe an alternative process by which germanium can be introduced onto a silicon platform, the quality of the deposited layer and thereby its performance is inferior to that produced through grading and thus do not pose a threat to the commercialization of graded substrate technology.

Unlike the devices fabricated using the abovementioned patents which have inferior performance, some patents found in the literature have equal performance. However, the nature of the growth technique makes it unsuitable in its current stage of development for the intended solar cell application and thus is not a current threat. Amongst those found include:

6,835,246 Nanostructures for hetero-epitaxial growth on silicon substrates
J. W. Mathews et al., J. Appl. Phys. 41, 3800 (1970) Finite area growth
Y. H. Lo, Appl. Phys. Lett. 59, 3211 (1991) Growth on compliant substrates

These abovementioned references deal with the problems created when germanium is grown on silicon in different ways. One method proposed is to grow germanium on silicon substrate that has been thinned to make it pliable. This flexibility allows for the accommodation of elastic strain built up due to lattice constant mismatch. Therefore germanium can be grown thus with a reduced defect density. Although this also a form of heterointegration, substrate compliance is undesirable if subsequent layers must be deposited as deposition uniformity is compromised. Also, for such a level of compliance to be possible throughout an entire wafer, the substrate would have to be of the order of a few nanometers thick. A wafer of such dimensions would be too fragile such that even the slightest mishandling will cause cracks to form.

Finite area growth of germanium on silicon has achieved high quality germanium on silicon directly without any intermediate layer which is a desirable result. However, the sizes of these individual areas are in the micron range and are discontinuous at the macro scale. This makes the grown device unsuitable for solar cell application because even solar modules which make use of concentrator technology to reduce substrate size have areas in the millimeter range. Also the thermal expansion coefficient mismatch at the abrupt silicon to germanium interface may compromise device performance if further processing after deposition is required.

The final subcategory of patents filed is those which are related to various strategies explored in grading, and this including several those filed by Motorola which have turned out to

be a hoax. Nevertheless, although these patents may not pose any threat in the immediate future, however, advancements in these areas may suddenly bring these relatively unknown techniques into the limelight. Thus, a close watch must be maintained to look out for any advancement in these fields. Several patents that fall within this category include:

- 6,897,471 Strain-engineered direct-gap Ge/Sn_xGe_{1-x} heterodiode and multi-quantum-well photodetectors, laser, emitters and modulators grown on Sn_ySi_zGe_{1-y-z}-buffered silicon
- 6,372,981 Semiconductor substrate, solar cell using same, and fabrication methods thereof
- 4,769,341 Method of fabricating non-silicon materials on silicon substrate using an alloy of Sb and Group IV semiconductors
- 4,928,154 Epitaxial gallium arsenide semiconductor on silicon substrate with gallium phosphide and superlattice intermediate layers

It should be noted however that silicon and germanium are immiscible in tin. Therefore, using graded layers of increasing tin composition will not work because intermediate alloy compositions cannot be formed. Therefore, whilst basic thermodynamics is not violated, some techniques that have been patented may not be physically possible.

Until now, the focus of patent literature research has been on alternative grading strategies. However, the commercialization of graded substrate technology also involves the implementation of a III-V multijunction solar cell grown on the graded substrate. To this end, there are also many patents that deal with the fabrication of such devices in its various configurations. Examples of such patents include:

- 6,951, 819 High efficiency, monolithic multijunction solar cells containing lattice-mismatched materials and methods of forming same
- 6,459,034 Multi-junction solar cell
- 6,340,788 Multijunction photovoltaic cells and panels using a silicon or silicon-germanium active substrate cell for space and terrestrial applications
- 5,853,497 High efficiency multi-junction solar cells
- 5,405,453 High efficiency multi-junction solar cell
- 4,295,002 Heterojunction V-groove multijunction solar cell

The prevalence of such multijunction solar cell patents means that in commercializing graded substrate technology, care must be taken to ensure that the multijunction solar cell fabricated on the graded substrate does not infringe on these patents to prevent unnecessary loss to license fees. The alternative to this would be to partner organizations which have these existing patents and then license their design to reduce research time and minimize the chances of intellectual property infringement. The abstract summaries of these patents can be found in Appendix 3. Such partnerships are critical to the market penetration of graded substrate technology and bring to these business partners the novelty of having larger substrate area solar cells as compared to existing cells grown on germanium substrates.

On the route to commercialization of graded substrate technology, it is also important to consider the patents that have been filed by existing companies that deal with multijunction solar

cells. Two such companies that deal with III-V multijunction solar cell for space applications are Emcore and Spectrolab. Some of their patents in the solar cell area are given below:

Emcore:

- 6,864,414 Apparatus and method for integral bypass diode in solar cells
- 6,680,432 Apparatus and method for optimizing the efficiency of a bypass diode in multijunction solar cells
- 6,653,215 Contact to n-GaN with Au termination
- 6,617,508 Solar cell having a front-mounted bypass diode
- 6,600,100 Solar cell having an integral monolithically grown bypass diode

Spectrolab:

- 5,508,206 Method of fabrication of thin semiconductor device
- 5,460,659 Concentrating photovoltaic module and fabrication method
- 5,330,585 Gallium arsenide/aluminum gallium arsenide photocell including environmentally sealed ohmic contact grid interface and method of fabricating the cell
- 5,100,808 Method of fabricating solar cell with integrated interconnect
- 5,034,068 Photovoltaic cell having structurally supporting open conductive back electrode structure, and method of fabricating the cell
- 4,698,455 Solar cell with improved electrical contacts

It is important to note that these patents deal with the specific solar cell designs of their licensing companies, such as the monolithic bypass diode, contact formation and manufacturing strategy. In the commercialization of solar cells grown on graded substrates, the solar cell design must be different from those currently protected by patents and this would therefore mean time and money required in research and development of a exclusive design. The summary abstracts of these patents can be found in Appendix 4 for Emcore and Appendix 5 for Spectrolab.

The last set of patents that are important for our consideration is are those dealing with the use of concentrators in solar applications. This is a nascent area of research that is becoming increasingly important due to the potential cost saving as well as efficiency increases that the use of concentrators may bring about. Examples of patents that fall into this category include:

- 6,469,241 High concentration spectrum splitting solar collector
- 6,252,155 Space concentrator for advanced solar cells
- 5,374,317 Multiple reflector concentrator solar electric power system

The main thrust of these patents is to protect the various concentrator solar cell designs that have been put forward by various parties. The design described in these patents are not as efficient as those which are currently in research (the use of Fresnel lens) and thus do not pose a threat to the business proposal. However, the concentrator solar market is also not without existing players with their trademarked designs such as SunBall™ and FLATCON™. Therefore, in considering these facts, to negotiate the concentrator solar market would mean either a development of an exclusive design or partnership with these existing companies to move ahead.

Competing solar cell technology

The competition concern in this section is whether there exist other materials systems that potentially are able to outdo III-V multijunction solar cells. To dispel these potential fears the diagram on the right considers the theoretical maximum efficiency of various materials systems.^[15] Clearly, it can be seen that III-V materials (in this context, gallium arsenide) has the highest theoretical maximum efficiency and thus it is safe to conclude that the performance limit will not be an issue.

In order to ensure that multijunction solar cells is the way to go, a literature search is carried out to compare multijunction solar cells with thermophotovoltaics. Firstly, for single junction pn solar cells, the semiempirical Shockley-Queisser limit suggests a maximum efficiency of 30% at a bandgap of 1.1eV and unity radiative recombination.^[16] For multijunction solar cells, the limiting efficiency is 68.2% for 1 sun illumination and 86.8% for 45900 suns intensity for an infinite number of cells.^[17] Under edge illumination, the theoretical efficiency of such multijunctions are calculated to be 64% at 1 sun intensity, increasing to 77% at 1000 suns and 81% at 10,000 suns.^[18] Thermophotovoltaics come in a close second with limiting efficiencies of 85.4% and 54% under concentrated and non-concentrated sunlight respectively. These statistics pale however in comparison to the maximum efficiency of 93% at the thermodynamic limit.^[19] From this comparison, it is clear that III-V multijunction solar cells perform best in comparison with other solar cell technologies and thus is at an advantage in entering the existing solar cell market. Also, the plot on the following page compares the efficiencies of solar cells that have been reported in existing literature by various research groups, showing that III-V multijunction solar cells indeed have the highest efficiencies to date.

An important development in the area of solar cell research in the recent years is the use of concentrating lenses to reduce cost and improve device performance. The idea behind this technology is similar to the use of a magnifying glass to focus the sun's rays onto a spot on a piece of paper. The use of a Fresnel lens performs the same function as the lens in a magnifying glass and focuses the incident radiation falling on a large area onto a small area of solar cell. This has been shown to improve solar cell efficiency beyond 30% and at the same time reduce cost as less amount of expensive solar cell is required. A review of the concentrator solar cell literature shows the improvement of efficiency under concentration of 489 suns to 38.9% using triple junction solar cells.^{[20],[21]} Also, solar cells do not fail even under a concentration of 1000 suns.^[22] Along with the development of concentrating lenses is the characterization of new materials that are lattice matched and of the correct bandgap energy for four and five junction solar cells. Development in this area of research is critical in the business proposition of graded substrate solar cells because advancements in this area can be tapped on for better device performance. This is one advantage that graded substrate solar cell technology has that conventional silicon solar cells do not enjoy. Several concentrator papers examined in the course of this work are highlighted in Appendix 6 for further reference.



Best Research-Cell Efficiencies

www.nrel.gov/ncsp/water_for_dps/ncsp_best_research_cell_eff

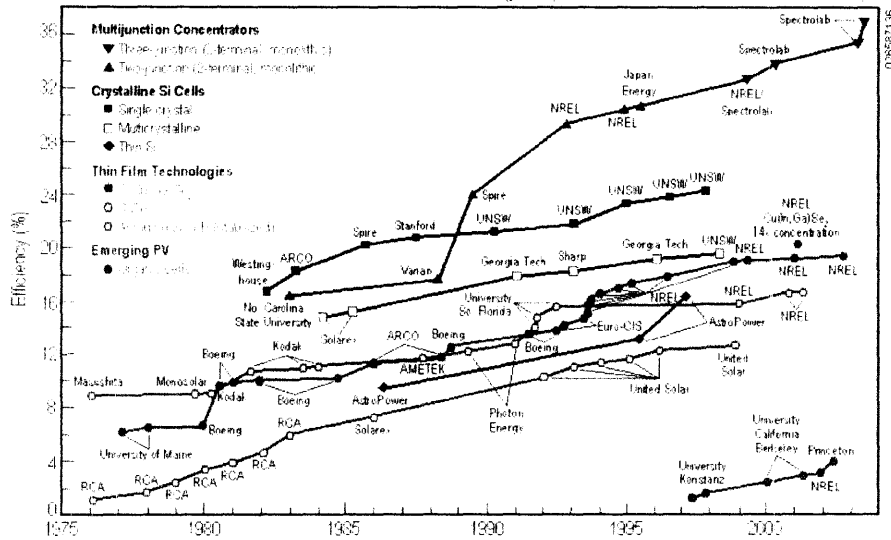

Figure 1. Best solar cell efficiencies reported in existing literature^[23]

Competing solar cell manufacturers

In the previous sections, the intellectual property space covered by graded substrate patents and other competing technologies were discussed. Also the superiority of III-V multijunction solar cells in comparison to solar cells made from other materials and designs was shown. These two points serve to show that there is huge potential in bringing graded substrate technology into the solar cell market because not only is the intellectual property space protected, but it also allows the current silicon dominated solar market to have access to high efficiency III-V materials.

This section carries on the feasibility discussion from another angle, to consider the major solar players in the world and Europe as identified by the European Union for the year 2005.^[24] This exercise serves to identify potential business partners as well as competitors in the solar market. Sharp Corporation is the current world leader with the largest market share and production volume, followed by Kyocera and BP Solar (a short description of Sharp Corporation is given in Appendix 7). In Europe, Q-Cells, a Danish company leads the pack followed by RWE-Schott Solar (also a Danish company) and Isofoton. Despite the numerous companies that deal with solar cells, these can all be categorized into different categories based on what type of solar cells they produce. This is given in appendix 8 where companies are divided according to whether they use single crystal silicon, polycrystalline silicon, and amorphous silicon or II-VI materials for fabricating the solar cell.

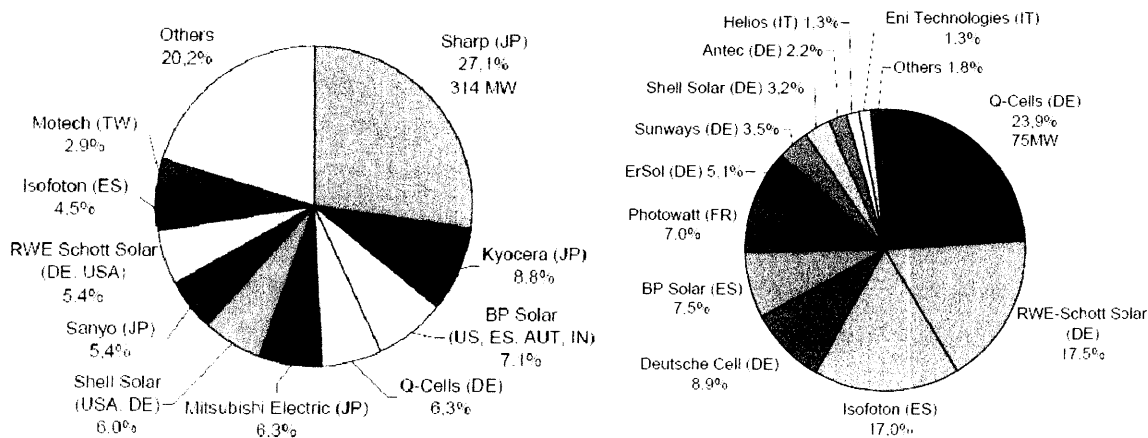

Figure 2 (left) and 3 (right). Top ten solar companies in 2004^[25] (left) and shares of European PV companies in European production^[26] (right)

Going one step further, a short writeup of various Japanese companies are given in Appendix 9. Many Japanese companies such as Kyocera, Mitsubishi Electric and Kaneka Corporation are all involved in the production of polycrystalline silicon solar cells. Therefore, because graded substrate technology requires growth on monocrystalline silicon, these companies will be less likely to be interested in this new technology and thus would be business competitors rather than partners. Mitsubishi Heavy Industries, Canon, Sanyo Electric and Daiwa House are companies that are currently involved in the production of amorphous silicon solar cells. These companies do not have the necessary processing equipment or technical knowledge base to support graded substrate technology, and a change of investment into monocrystalline silicon will be too great an investment risk. As such, these companies will most probably also be competitors rather than consider implementing graded substrate technology.

Two potential business partners in the list of Japanese companies are MSK Corporation and Tokuyama Corporation. MSK Corporation manufactures solar modules from solar cells of different manufacturers. Thus a potential business strategy could involve outsourcing solar module manufacturing to MSK Corporation rather than increasing the investment capital to have an in-house solar module assembly facility. Tokuyama Corporation is a manufacturer of electronics and solar grade silicon. The introduction of graded substrate technology could potentially improve their profits because of the efficiency improvement that it brings. A potential business strategy could either involve procurement of silicon substrates from Tokuyama Corporation and then selling the modified wafers to them in return or capitalizing on their established distribution network to market graded substrate wafers.

After considering the Japanese market players, the next group of players to be considered are those who in the China and Taiwan region. As before, a short writeup of these companies are given in Appendix 10. Amongst these players, Motech Solar, E-Ton Solartech, Suntech Power and Nanjing PV-TECH are examples of companies that are already dealing with monocrystalline silicon. The possibility of these companies being interested in graded substrate technology is higher for reasons mentioned earlier. Also, the expansion of solar energy generation into the Chinese and Taiwanese markets has been ongoing at a rapid pace and thus business partnerships with these companies will provide strategic avenues for market penetration. Other companies in

this geographical region include Sinonar Corporation, Green Energy Technology, Tianwei Yingli New Energy Resources and LDK Solar. These companies are involved in the production of polycrystalline or amorphous silicon solar cells and thus would probably not be interested in adopting graded substrate technology.

The next geographical area of interest is the United States. A short summary of the business activities of US based solar companies can be found in Appendix 11. Amongst those companies which may be potential business partners are BP Solar and Shell Solar. These companies have well established distribution networks and have strong branding. A business partnership with these companies will not only bring the graded substrate technology advantages to the solar cells that they market, but also increase market awareness of the technology as well. On the other hand, GE Energy, United Solar Ovonic and First Solar are dealing with amorphous silicon and II-VI solar cells and therefore would not be interested in graded substrate technology.

The final group of companies in consideration is those based in Europe. A short writeup of these companies can be found in Appendix 12. Among the companies that market monocrystalline solar cells in this region include Isofoton, Q-Cells AG, RWE-Schott Solar, Solar World AG, ErSol Solar Energy and Sunways AG. Several of these companies such as Isofoton, Q-Cells and RWE-Schott are amongst the top ten solar market players worldwide. Partnerships with these companies will aid the penetration of graded substrate technology into the European market. Other companies based in Europe which is involved in polysilicon solar cell manufacture include Photowatt, Photovoltech and Würth Solar which produces CIS solar cells. PV Crystalox Solar AG, Renewable Energy Corporation and Siltronic AG are companies that are silicon wafer manufacturers based in Europe. Again, partnership with these companies either for supplying silicon wafers or to market graded substrate wafers to their customers may be a means to bring this technology into the European market.

Two companies which deserve special mention are Emcore (Appendix 13) and Spectrolab (Appendix 14). These two companies deal with high efficiency multijunction III-V solar cells which are used to power space satellites. These two companies are key potential business partners because making the transition to graded substrate wafers save precious weight from solar cells, and silicon wafers are inherently not only lighter but also stronger. Because the potential of substantial weight savings through the use of graded substrates, this technology will possibly be attractive to these companies and a partnership with these companies will introduce graded substrates to the space solar market.

The worldwide market^[27]

In the previous section, the various competing business ventures that are against the commercialization of graded substrate technology were examined. These ranged from competing intellectual property to alternative solar cell materials and designs. Also the various global players in the worldwide solar market were elucidated and evaluated for their potential as business partners. This section considers the worldwide market for space solar and residential photovoltaic applications, and examines the various countries that are leading the push for solar energy implementation.

The worldwide market for residential PV currently stands at approximately 14.26 billion US dollars in 2006, and is dominated by several countries namely China, Japan, the United States and countries within the European Union.^[28] Around the world, governments are the main pushers for increased dependence on solar power. Through the introduction of various laws regarding the use of renewable energy, promoting continued research into green technologies and also providing subsidies for companies as well as the end consumers, governments play a major role in market creation.

The largest number of installed systems in 2004 came from Germany (363 MW) due to the introduction of a new feed-in law. Also, for the almost 1GW of cumulative installed capacity in the European Union from 2001 to 2004, approximately 80% of these systems were installed in Germany. The second largest market worldwide is Japan at 268.8 MW of new installations, and the Japanese market is growing at a rate of approximately 25.5%. The third largest market is the United States at 90 MW of installed systems in 2004, with the state of California contributing 60 MW. Until recent years, the US PV market was dominated by off-grid applications such as remote residential power, industrial applications, telecommunications and infrastructure, such as highway and pipeline lighting or buoys. This has since changed with the introduction of new state laws concerning utilities. The last market considered is that of China. Although the market is small but the growth is expected to be drastic as the national goal is to supply 10% of the total primary energy in 2020 by renewable energy.

To illustrate the effect that the various government policies have on market creation in different countries, a summary of the government policies governing the proliferation of solar energy in Japan is given in Appendix 15. The main driving force behind the growth of the solar market in Japan is the stimulation of continuous ongoing research and development whilst providing incentives for market growth. This has created a sustainable industry that is already mature and a thriving research culture. Because the majority of the policies regarding solar energy involve residential applications, the Japanese solar market is dominated by the demand for residential on-grid systems.

Unlike Japan which has a mature photovoltaic industry and government policies set up in place, the solar market in China is not as comprehensively legislated. However, the solar market in China is rapidly growing because of the standards and goals set by the Chinese government. This rapid growth rate coupled with the expansion plans of Chinese companies make China an important market where residential photovoltaic systems retail is concerned. A short summary of the various developments of the renewable energy policy in China is given in Appendix 16.

The market that has been established in the United States is also different from that of China and Japan. Firstly, President Bush unveiled a large increase in the solar energy research budget in an effort to reduce the dependence of America on Middle East oil. Also, two states, California and New Jersey are leading the way in solar proliferation. The space solar market in the US as mentioned earlier is dominated by two companies, Emcore and Spectrolab which supply high efficiency III-V multijunction solar cells for satellite power generation. This increase in tax rebates makes California and New Jersey important markets in the US for residential photovoltaic systems. Also the increase in research funding is an important catalyst for further

solar cell development to be carried out across the country. Excerpts from various press releases regarding solar policy matters in the US can be found in Appendix 17.

The last geographical region of interest is Europe. The main institution setting the direction for the development of solar energy and solar policies is the European Photovoltaic Industry Association (EPIA). Through the EPIA, a climate for solar energy research in Europe is created and also the implementation of various incentives to encourage home owners and businesses in the solar industry. Also, Germany has become an important market that is rapidly growing, and through the regulatory framework that is set up, other countries in the European Union are gradually following suit. The objectives of the EPIA, the potential of the European market as well as the various incentives in the EU countries are given in Appendix 18.

The second important market that is considered in this section is the space solar market. A rough estimate of the size of this market is to the order of US\$ 864 million per annum (see Appendix 19). As mentioned earlier, the space solar market is dominated in the US by Emcore and Spectrolab, and in Europe by RWE-Schott Solar. These three companies are important target audiences to market graded substrate technology to given their position in the space solar market as well as the advantages that the technology brings as well.

Performance and cost analysis

In the previous sections, the target markets as well as the main challengers in these markets were examined. Armed with this analysis, a business strategy is now put forward for commercializing the graded substrate technology. To begin, several comparisons must be quantified, i.e. when the word “better” is used, the specific “how much better” must be justified. This preliminary look into the actual figures will serve as a launching pad into the next section which discusses the business strategy in greater detail.

To begin, the first area of consideration is for the space solar market. The advantage that graded substrates have is that current III-V substrates are limited to at most six inch wafer sizes. These six inch wafers are already prohibitively expensive and have to be specially ordered. Silicon wafers on the other hand have already twelve inch wafers in commercial production. In comparing the doubling of wafer size from six to twelve inches, the additional area advantage that one gains in processing per wafer is four times. This translates to a higher final throughput as fewer wafers are required to tile the same surface. Also, since fewer wafers are required for the same area coverage, the assembly time required will also be reduced. This is not including the savings on reinforcement that would be necessary for the more fragile III-V wafers compared to silicon whose modulus is approximately 1.8 times higher. Above all these advantages, the weight savings in going from germanium to silicon is substantial and is sufficient to offset any cost barriers as will be illustrated later on.

To consider the business advantage of graded substrates in greater detail, a cost model must first be developed to ascertain the approximate cost of production as well as the capital investment required for operations to begin. The cost model developed begins by estimating the cycle time required for the various products, namely, germanium virtual substrate wafers, GaAs

virtual substrate wafers and finally complete solar cells. A repayment period of six years is set for the return of investment capital, this is expressed as 50% of the initial capital investment for three years because it is expected that investment firms will begin investing in the graded substrate venture once the outlook for the business begins to look up. Given this three year window, the production volume can then be ascertained given the cycle time of the various substrates and solar cells. The numerical details of the cost model are given in Appendix 20.

In developing the cost model for the production of the various substrates, the capital investment required can be calculated since the equipment and labor costs are known or can be estimated. From this the production cost required per virtual substrate or solar cell can be determined. Since the calculation was done assuming only a six inch diameter for the substrates and solar cell, the extrapolation to other sizes, four, eight and twelve inches are done considering the same production cost per unit area. This is potentially a good rule-of-thumb because the stabilized production costs in the long run and in the mass production scenario should reach this value.

In order to compare these production costs with commercially available substrates, the same cost per unit area analysis was done for existing germanium and GaAs substrates. Also, because twelve inch silicon wafer prices were unavailable off the internet, the cost of such wafers was also derived using the same means. Assuming the same utility for equal retail prices, this would place the utility of graded substrates at a higher value because they can be produced for a lower production cost. To compare graded substrates and their commercially available counterparts at the same utility value (the point where customers hypothetically have no preference), then the retail price of graded substrates will be equal to that of commercially available ones. The potential profit thus generated would therefore be the retail price of the commercially available substrate subtracting the production cost of a graded substrate.

However, to make graded substrates more appealing for market acceptance, they are sold at almost 50% cheaper than their commercially available (or equivalent cost-per-area) counterparts. Also a factor of 10% interest rate on the capital investment has to be added into the cost price. In spite of all these limitations, these graded substrates can be sold at 150% of their production cost, resulting in 40% of the production cost being counted as profit. These profits range from US\$ 103,000 to US\$ 1,090,000 for germanium wafers and US\$ 142,000 to US\$ 1,280,000 for GaAs wafers per annum over the three year period of consideration.

The same strategy to measure utility is changed slightly for the assessment of solar cells. In order to calculate the approximate cost per solar cell, not only must the cost of the entire solar module and its breakdown be known, but also the amount of incident solar radiation at the place of purchase because that would determine the area of solar cells required or the number of solar cells needed. Knowing the cost breakdown of the entire photovoltaic system, the contribution from the solar cells can be derived. This divided by the number of solar cells gives an approximate cost per solar cell. An additional complicating factor was the efficiency of the solar cells in the module because less high efficiency cells would be required as compared to a greater number of low efficiency ones.

At higher efficiencies, less number of solar cells is required to generate the same amount of power. This means that for the same retail price of the solar module, each solar cell can cost more to produce. Assuming the graded substrate solar cells are at the initial demonstrated efficiency of 18.6%, the number of solar cells required is large and thus the production cost is greater than the retail price and therefore a loss is incurred. However, if triple junction solar cells are fabricated on graded substrates and concentrator technology is used to boost efficiency to the 32% of FLATCON™ or the world record efficiency of 38.9%, then because graded substrate solar cells at these efficiencies are cheaper to produce than existing ones, therefore the possibility of profit exists. Indeed, the reduction of expensive substrate area through the use of concentrator technology will enable the marketing of graded substrate solar cells in the largely residential PV dominated solar cell market.

Currently, residential PV systems utilizing concentrator technology are already in the market, examples of which include FLATCON™ and SunBall™. In the development of concentrator technology, issues such as efficient sun tracking and heat dissipation problems, as well as the design of larger focusing lens are current areas of research. However, because the emphasis of current commercial concentrator systems is not to achieving the maximum attainable efficiency but rather to just improve current values to the thirty percent region; therefore, these research issues are still not resolved in existing commercialized solutions.

In modeling the potential profits resulting from the sale of concentrator solar cells, as mentioned earlier, an efficiency of 18.6% from the initial dual-junction solar cell is too low to create a substantial profit. However, extrapolating the fabrication of triple junction solar cells on such graded substrates assuming the same cost of production would place graded substrate solar cells in a favorable position in comparing with solar cells used in FLATCON™ panels. For an interest rate of 10% on the capital investment whilst giving a discount of 14% compared to the cost of existing solar cells, a profit of 20% of the production cost can still be made. The annual profit thus calculated ranges from US\$ 18,000 to US\$ 250,000.

The last and perhaps most lucrative market of all is the sale of graded substrate solar cells for the space solar market. The reason for the large profit margin in the space solar market is because of the substantial amount of cost savings when comparing the reduced weight of a silicon substrate against a germanium substrate. This weight savings translate to a cost savings because of the prohibitive payload cost for launching satellites. This cost savings can also be thought of in a certain sense as “profit” because now the amount required to send the incremental weight of one solar cell into space is less. To model the annual profit for this market segment, an interest rate of 20% was assumed on the capital investment. The retail price of these graded substrate solar cells were also pegged at 50% of the cost savings. For example if the transition from conventional solar cell to a graded substrate one saved a payload cost of US\$ 4,000, the solar cell was sold at a price of less than US\$ 2,000, thus potentially doubling the manufacturers’ profit. Also, for UHVCVD, because the cycle time is significantly slower than graded substrates grown using LPCVD, the profit was only 60% of the production cost per wafer as compared to 280% of the production cost per wafer for LPCVD solar cells.

To give an example of how the profit calculation was done, assume that the production cost of a UHVCVD graded substrate solar cell was US\$ 1,000. Since 60% of the production cost

was added to the retail price and taken as profit and an additional 20% was added due to the interest rate on the initial capital investment, the final retail price of one such solar cell would then be US\$ 1,800. This would be more than 50% less than the cost savings in making the transition from conventional solar cell to a graded substrate cell, with a payload saving of US\$ 4,000 similar to the figure quoted in the earlier example.

This calculation represents a very real and practical business opportunity for the commercialization of graded substrates and solar cells for the space solar market. The weight savings has potentially allowed these cells to be sold at a significant profit margin, and this is estimated to be anywhere from US\$ 186,000 to US\$ 1.68 million in profits can be generated for UHVCVD solar cells and US\$ 736,000 to US\$ 6.62 million for LPCVD solar cells.

This section has examined the potential profits generated from the different business routes, from the retail of graded substrates to graded substrate solar cells and in the residential PV and space solar market. With these profit considerations in mind, a practical business strategy is put forward for the commercialization of graded substrate solar cells.

Business strategy

Given the performance and cost analysis done in the previous section, a practical business strategy is developed here by first considering the amount of initial capital outlay required for graded substrate or solar cell production. It is clear that the initial capital investment required for operations to begin is very high, and entering the market as an unknown player, and competing with established companies not only in the residential PV but also in the space solar market, the chances of survival are low.

A further complication to this difficulty as mentioned previously is that the initial solar cell demonstration was for a dual junction solar cell fabricated on a graded substrate. To fully utilize III-V multijunction solar cell efficiencies on graded substrates, triple junction solar cells must be fabricated. There are two possible ways to overcome this problem. Firstly, substantial time, effort and capital have to be invested in order to develop and patent an original solar cell design. The second alternative is to license an existing design in collaboration with either Emcore or Spectrolab for a licensing fee. Fabricating a triple junction solar cell on graded substrates increases the competitive edge of graded substrate solar cells significantly, thus allowing penetration into the residential PV market with the help of concentrator technology.

Nevertheless, the difficulty of raising venture capital remains, and a proposed solution to this problem is to outsource the fabrication of graded substrates and solar cells to production houses. This allows the reduction of initial capital outlay required whilst still being able to produce a small volume of products to gauge market interest as well as to demonstrate actual device feasibility. However, outsourced production is not a long term solution because in large volumes, it would definitely be much cheaper to have a dedicated manufacturing facility.

An important step in the commercialization of graded substrate technology is the partnership with existing companies, either in the sales of graded substrates or complete solar

cells, licensing the technology for use, or making use of their established distribution networks as an avenue to market graded substrate products. In order for effective partnership, these companies should have development trends into next-generation PV technology, have an established distributor network and have strong branding and regional if not global presence. Naturally, companies which are already dealing with monocrystalline silicon or III-V multijunction solar cells will be more inclined to become business partners.

Three groups of companies are identified, namely, silicon wafer providers, monocrystalline silicon and III-V multijunction vendors, and solar module assembly houses. Silicon wafer provider companies include Siltronic, REC and PV Crystalox. Because these companies provide the base silicon substrate upon which graded buffers are grown on, partnership with these companies could potentially lower costs, whilst these virtual substrates could be included in their product lists and thus tap on their existing distribution networks. The various solar cell manufacturers such as Sunways, Ersol and BP Solar for example stand to benefit in the potential increase in efficiency of graded substrate solar cells and through the implementation of concentrator technology. Space solar vendors such as Emcore, Spectrolab and RWE Schott stand to reduce substrate costs through the use of graded substrates. Finally, collaboration with MSK Corporation all provide an avenue to outsource solar module production and implement graded substrate technology throughout the entire photovoltaic chain.

The final potential way of engaging existing companies would be to start on this technology on a preliminary trial basis. It is estimated that for a company like Sharp which produces 400 MW of solar cells per annum, a trial using 0.01% of this production figure at a licensing fee of only 1% of the retail price will generate a profit of US\$ 244,000 to US\$ 333,600 per year. Should the company be satisfied with the trial results, larger capacities can then be considered and the profit generated could be then channeled back into the business in the building of a dedicated full scale manufacturing facility rather than depending on IP sales or outsourced production. This option may appeal more to companies which already have the manufacturing facilities in place and would prefer to just gain the technical expertise in this area.

The choice of which initial market to target is also important to maximize the chances of commercialization success of graded substrates. Therefore, targeting the space solar market on the onset is important because of the significant cost savings brought about by the weight reduction in the transition from commercially available to graded substrate solar cells. An initial entry into this market will facilitate the buildup of production volume of not only graded substrate solar cells but also increase market demand for to make the production of graded substrates profitable as well. Increasing the capacity of graded substrate production will then facilitate the entry of this technology into the residential PV arena, having given time for the development of concentrator technology as well as triple-junction solar cells. The firm establishment of graded substrate technology will then serve as a launching pad into the lasers and optical interconnect market when research in these areas have reached a sufficient level of maturity.

Therefore, a summary of the business strategy presented in this section would involve the sale of graded substrates in markets where its advantages of light weight and lower production cost are fully utilized before further expansion into less mature, smaller volume markets.

Conclusion

Through the course of this thesis, the commercialization of graded substrate technology has been considered in its various facets. Beginning with a discussion in the global trends of heterointegration and renewable energy these has set the stage for unveiling graded substrate technology. An examination of graded substrate technology then ensued, looking at how these buffers are fabricated before elaborating on their potential use in the solar market.

The next important section considered the various opposing forces to this technology, from potential intellectual property conflicts to alternative material systems and existing market players. An important next step was then to consider the profits that the sale of these germanium and GaAs virtual substrates as well as solar cells could bring, and quantify the various costs and capital required to begin operations.

Assembling all these pieces together, a business strategy was proposed to circumvent all these obstacles. This strategy for market penetration can be summarized in the following four 'P' bullet points:

- Partnership with silicon wafer producers to tap on existing distribution networks
- Positioning ourselves as graded substrate retailers to solar companies
- Producers of complete PV systems through MSK Corporation
- Providers of intellectual property

The main thrust of the business strategy is to introduce graded substrate solar cells for the space solar market. This market was identified to be the most advantageous market to begin commercialization and to slowly scale up production volume of not only of graded substrate solar cells but also the capacity of the graded substrates themselves. Once stable in this market, expansion into the lower profit margin residential PV market is then economically feasible. Through this process of gradual expansion, sufficient profits can then be made to drive research and demand for markets such as optical lasers and interconnects which have a smaller demand and volume.

This thesis began looking at global technological trends. To conclude, these trends also play a part in the responsiveness of the market to the introduction of graded substrate technology. Heterointegration strategies may steer away from silicon and III-V materials, rendering our technology less desirable. Alternative energies sought could involve hydroelectricity, nuclear power and also coal amongst others and thus result in a delayed take-up of solar power. Given then the current market situation and technological trends and barring any unexpected new developments, graded substrate technology is the stopgap solution for now and therefore capitalize on this opportunity that is not to be missed!

References:

1. N. Lucas, H. Zabel, H. Morkoc, and H. Unlu, *Appl. Phys. Lett.* 52, 2117 (1988)
2. D. K. Biegelsen, R. D. Bringans, and J. E. Northup, *Mater. Sci. Eng., B* 14, 317 (1992)
3. M. K. Hudait, P. Modak, S. Hardikar, K. S. R. K. Rao, and S. B. Krupnidhi, *Mater. Sci. Eng., B* 55, 53 (1998)
4. M. Ting and E. A. Fitzgerald, *J. Appl. Phys.* 87, 2618 (2000)
5. R. M. Sieg, S. A. Ringel, S. M. Ting, E. A. Fitzgerald, and R. N. Sacks, *J. Electron. Mater.* 27, 900 (1998)
6. M. T. Currie, S. B. Samavedam, T. A. Langdo, C. W. Leitz, and E. A. Fitzgerald, "Controlling threading dislocation densities in Ge on Si using graded SiGe layers and chemical-mechanical polishing," *Appl. Phys. Lett.*, vol. 72, no. 14, pp. 1718–1720, Apr. 1998.
7. S.A. Ringel et. al., *Anti-phase Domain-free GaAs on Ge substrates grown by Molecular Beam Epitaxy for Space Solar Cell Applications*, IEEE 1997
8. David M. Wilt et. al., Thermal cycle testing of GaAs on Si and metamorphic tandem on Si solar cells. IEEE 2005
9. E.A. Fitzgerald, M.E. Groenert, A. Pitera, M.L. Lee, V. Yang, J.A. Carlin, C.W. Leitz, C.L. Andre, S.A. Ringel, "The Science and Applications of Relaxed Semiconductor Alloys on Conventional Substrates", 3rd World Conference on Photovoltaic Energy Conversion May 11-18, 2003
10. Michael E. Groenert et. al., *Monolithic integration of room-temperature cw GaAs/AlGaAs lasers on Si substrates via relaxed graded GeSi buffer layers*, *Journal of Applied Physics*, Vol. 93, Number 1, 1 January 2003
11. David M. Wilt et. al., Thermal cycle testing of GaAs on Si and metamorphic tandem on Si solar cells. IEEE 2005
12. D. Wilt, NASA, PVSC Conference, Hawaii 2006
13. Carrie L. Andre et. al., *Investigations of High-performance GaAs Solar Cells Grown on Ge-Si_{1-x}Ge_x-Si Substrates*, *IEEE Transactions on Electron Devices*, Vol. 52, No.6, June 2005
14. C. L. Andre, D. M. Wilt, A. J. Pitera, M. L. Lee, E. A. Fitzgerald, and S. A. Ringel, "Impact of dislocation densities on n+/p and p+/n junction GaAs diodes and solar cells on SiGe virtual substrates," *J. Appl. Phys.*, vol. 98, Jul. 2005. art. 014 502
15. <http://www.solarserver.de/wissen/photovoltaik-e.html>
16. William Shockley and Hans J. Queisser, "Detailed balance Limit of Efficiency of p-n junction solar cells", *Journal of Applied Physics*. Volume 32, Number 3, March 1961
17. Alexis De Vos, "Detailed Balance limit of the efficiency of tandem solar cells", *J. Phys. D: Appl. Phys.*, 13 (1980) 839-46
18. J. E. Parrott, "The limiting efficiency of an edge-illuminated multigap solar cell", *J. Phys. D: Appl. Phys.*, Vol. 12, 1979
19. Landsberg P.T. 1977 *Photochem. Photobiol.* 26 313
20. Kenji Araki et. al., *Development of a new 550x Concentrator Module with 3J Cells, Performance and Reliability*, IEEE 2005
21. H.S. Lee et. al., *Field Test and Analysis: The Behaviour of 3-J Concentrator cells under the Control of Cell Temperature*, IEEE 2005

22. H. Cotal et. al., *Outdoor Operation of GaInP/GaAs/Ge Triple Junction Concentrator Solar Cells up to 1000 Suns*, 3rd World Conference on Photovoltaic Energy Conversion, May 11-18, 2003, Osaka, Japan
23. http://en.wikipedia.org/wiki/Image:Nrel_best_research_pv_cell_efficiencies.png
24. Arnulf Jäger-Waldau, PV Status Report 2005, European Commission, DG JRC, Institute for Environment and Sustainability, Renewable Energies Unit via Enrico Fermi 1; TP 450 I – 21020 Ispra, Italia, EUR 21836 EN
25. Ibid.,
26. Paul Maycock, PV News, 2005, ISSN 0739-4829
27. Arnulf Jäger-Waldau, PV Status Report 2005, European Commission, DG JRC, Institute for Environment and Sustainability, Renewable Energies Unit via Enrico Fermi 1; TP 450 I – 21020 Ispra, Italia, EUR 21836 EN
28. Ibid., 5.8 billion Euros in 2004, 40% growth rate and 1 Euro = US\$1.2544

Price list references:

1. <http://www.caeonline.com/forsale.html>
2. http://www.mticrystal.com/products_crystal.html
3. <http://www.labx.com/>
4. <http://www.emcgrath.com/catalog.html>
5. <http://www.waferworld.com/>

Appendix 1

Compositionally graded substrate growth

Growth technique described in:

M. T. Currie, S. B. Samavedam, T. A. Langdo, C. W. Leitz, and E. A. Fitzgerald, *Controlling threading dislocation densities in Ge on Si using graded SiGe layers and chemical-mechanical polishing*, Appl. Phys. Lett., Vol. 72, No. 14, 6 April 1998

Substrate wafer: (100) Si wafers offcut 6° to the in-plane <110>

Growth conditions: UHVCVD

Final Ge composition: 100%

Grading rate (% Ge μm^{-1}): 10

Total epitaxial thickness (μm): 12

Growth temperature ($^{\circ}\text{C}$):

50-76%:	750
76-100%:	550

Growth pressure (mT):

50-76%:	250
76-100%:	30

CMP @ 50%: yes

Threading dislocation density (cm^{-2}): $2.1 \pm 0.2 \times 10^6$

Crack density (cm^{-1}): 0

Particle density (cm^{-2}): 150 ± 10

RMS roughness (nm): 24.2

a_{\perp} of top layer (\AA): 5.6597

a_{\parallel} of top layer (\AA): 5.6409

Thermal expansion coefficient of Si (α_{Si}): $4.27 \times 10^{-6} \sim 2.57 \times 10^{-6} \text{ K}^{-1}$

Thermal expansion coefficient of Ge (α_{Ge}): 8.55×10^{-6} to $5.90 \times 10^{-6} \text{ K}^{-1}$

GaAs growth on graded substrate

Growth technique described in:

Sieg et al., *Device-quality GaAs growth by MBE*, J. Vac. Sci. Technol. B 16(3), May/June 1998

Additional requirements:

- 1) Ge capping layer required to minimize rough surfaces, carbon contamination and annealed to suppress APD formation.
- 2) Important to control initial As_2 exposure
- 3) MEE growth of very thin GaAs buffer layer (~10 monolayers or 3nm thickness) to block interdiffusion.

GaAs buffer thickness

0.1 μm experimentally shown to be sufficient in:

J.A. Carlin et. Al., *Impact of GaAs buffer thickness on electronic quality of GaAs grown on graded Ge/GeSi/Si substrates*, Appl. Phys. Lett., Vol. 76, No. 14, 3 April 2000

Demonstration of high performance GaAs solar cell

Carrie L. Andre, *Investigations of High-Performance GaAs Solar Cells Grown on Ge-Si_{1-x}Ge_x-Si Substrates*, IEEE Transactions on Electron Devices, Vol. 52, No. 6, June 2005

Maximum device area demonstrated at 4.0 cm²

Steven A. Ringel, *Multi-junction III-V photovoltaics on lattice engineered Si substrates*, IEEE 2005

Demonstration of dual junction In_{0.49}Ga_{0.51}P/GaAs solar cell on graded substrate

Appendix 2

Relevant Compositionally graded substrate patents

6,927,147 August 9, 2005

Coplanar integration of lattice-mismatched semiconductor with silicon via wafer bonding virtual substrates

A method of bonding lattice-mismatched semiconductors is provided. The method includes forming a Ge-based virtual substrate and depositing on the virtual substrate a CMP layer that forms a planarized virtual substrate. Also, the method includes bonding a Si substrate to the planarized virtual substrate and performing layer exfoliation on selective layers of the planarized virtual substrate producing a damaged layer of Ge. Furthermore, the method includes removing the damaged layer of Ge.

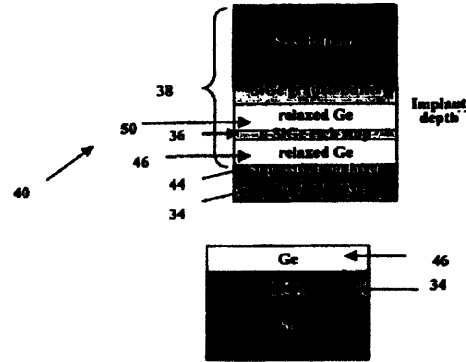

6,921,914 July 26, 2005

Process for producing semiconductor article using graded epitaxial growth

A process for producing monocrystalline semiconductor layers. In an exemplary embodiment, a graded $\text{Si}_{1-x}\text{Ge}_x$ (x increases from 0 to y) is deposited on a first silicon substrate, followed by deposition of a relaxed $\text{Si}_{1-y}\text{Ge}_y$ layer, a thin strained $\text{Si}_{1-z}\text{Ge}_z$ layer and another relaxed $\text{Si}_{1-y}\text{Ge}_y$ layer. Hydrogen ions are then introduced into the strained $\text{Si}_{1-z}\text{Ge}_z$ layer. The relaxed $\text{Si}_{1-y}\text{Ge}_y$ layer is bonded to a second oxidized substrate. An annealing treatment splits the bonded pair at the strained Si layer, such that the second relaxed $\text{Si}_{1-y}\text{Ge}_y$ layer remains on the second substrate. In another exemplary embodiment, a graded $\text{Si}_{1-x}\text{Ge}_x$ is deposited on a first silicon substrate, where the Ge concentration x is increased from 0 to 1. Then a relaxed GaAs layer is deposited on the relaxed Ge buffer. As the lattice constant of GaAs is close to that of Ge, GaAs has high quality with limited dislocation defects. Hydrogen ions are introduced into the relaxed GaAs layer at the selected depth. The relaxed GaAs layer is bonded to a second oxidized substrate. An annealing treatment splits the bonded pair at the hydrogen ion rich layer, such that the upper portion of relaxed GaAs layer remains on the second substrate.

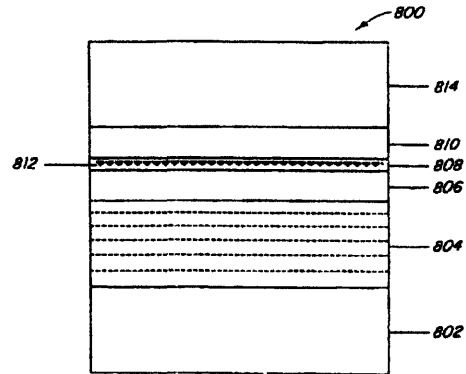

6,876,010 April 5, 2005

Controlling threading dislocation densities in Ge on Si using graded GeSi layers and planarization

A semiconductor structure including a semiconductor substrate, at least one first crystalline epitaxial layer on the substrate, the first layer having a surface which is planarized, and at least one second crystalline epitaxial layer on the at least one first layer. In another embodiment of the invention there is provided a semiconductor structure including a silicon substrate, and a GeSi graded region grown on the silicon substrate, compressive strain being incorporated in the graded region to offset the tensile strain that is incorporated during thermal processing. In yet

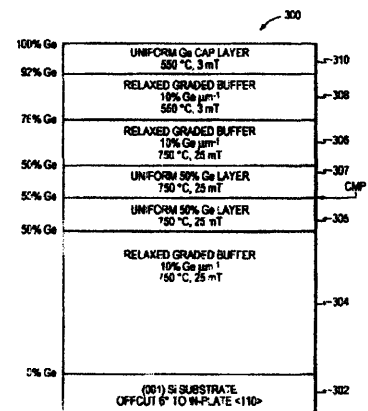

another embodiment of the invention there is provided a semiconductor structure including a semiconductor substrate, a first layer having a graded region grown on the substrate, compressive strain being incorporated in the graded region to offset the tensile strain that is incorporated during thermal processing, the first layer having a surface which is planarized, and a second layer provided on the first layer. In still another embodiment of the invention there is provided a method of fabricating a semiconductor structure including providing a semiconductor substrate, providing at least one first crystalline epitaxial layer on the substrate, and planarizing the surface of the first layer.

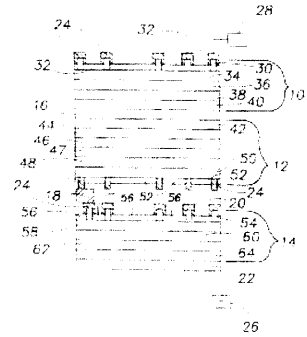

6,864,115 March 8, 2005

Low threading dislocation density relaxed mismatched epilayers without high temperature growth

A semiconductor structure and method of processing same including a substrate, a lattice-mismatched first layer deposited on the substrate and annealed at a temperature greater than 100.degree. C. above the deposition temperature, and a second layer deposited on the first layer with a greater lattice mismatch to the substrate than the first semiconductor layer. In another embodiment there is provided a semiconductor graded composition layer structure on a semiconductor substrate and a method of processing same including a semiconductor substrate, a first semiconductor layer having a series of lattice-mismatched semiconductor layers deposited on the substrate and annealed at a temperature greater than 100.degree. C. above the deposition temperature, a second semiconductor layer deposited on the first semiconductor layer with a greater lattice mismatch to the substrate than the first semiconductor layer, and annealed at a temperature greater than 100.degree. C. above the deposition temperature of the second semiconductor layer.

6,039,803 March 21, 2000

Utilization of miscut substrates to improve relaxed graded silicon-germanium and germanium layers on silicon

A method of processing semiconductor materials, including providing a monocrystalline silicon substrate having a (001) crystallographic surface orientation; off-cutting the substrate to an orientation from about 2.degree. to about 6.degree. offset towards the [110] direction; and epitaxially growing a relaxed graded layer of a crystalline GeSi on the substrate. A semiconductor structure including a monocrystalline silicon substrate having a (001) crystallographic surface orientation, the substrate being off-cut to an orientation from about 2.degree. to about 6.degree. offset towards the [110] direction; and a relaxed graded layer of a crystalline GeSi which is epitaxially grown on the substrate.

Appendix 3

Multijunction solar cell patents

6,951,819 October 4, 2005

High efficiency, monolithic multijunction solar cells containing lattice-mismatched materials and methods of forming same

In one embodiment, a method of forming a multijunction solar cell having lattice mismatched layers and lattice-matched layers comprises growing a top subcell having a first band gap over a growth semiconductor substrate. A middle subcell having a second band gap is grown over the top subcell, and a lower subcell having a third band gap is grown over the middle subcell. The lower subcell is substantially lattice-mismatched with respect to the growth semiconductor substrate. The first band gap of the top subcell is larger than the second band gap of the middle subcell. The second band gap of the middle subcell is larger than the third band gap of the lower subcell. A support substrate is formed over the lower subcell, and the growth semiconductor substrate is removed. In various embodiments, the multijunction solar cell may further comprise additional lower subcells. A parting layer may also be provided between the growth substrate and the top subcell in certain embodiments. Embodiments of this reverse process permit the top and middle subcells to have high performance by having atomic lattice spacing closely matched to that of the growth substrate. Lower subcells can be included with appropriate band gap, but with lattice spacing mismatched to the other subcells. The reduced performance caused by strain resulting from mismatch can be mitigated without reducing the performance of the upper subcells.

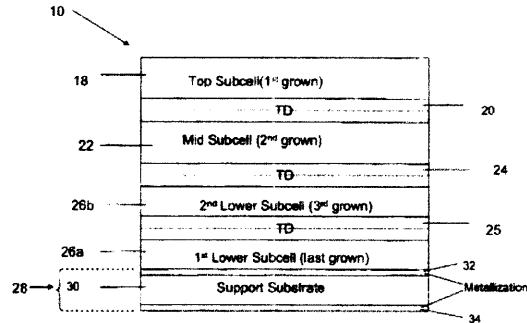

6,459,034 October 1, 2002

Multi-junction solar cell

A multi-junction solar cell comprising: a support substrate having a first electrode layer, a plurality of photoelectric conversion devices and a second electrode layer stacked thereon, and an intermediate layer having an uneven surface being sandwiched between any two of the photoelectric conversion devices stacked adjacent each other.

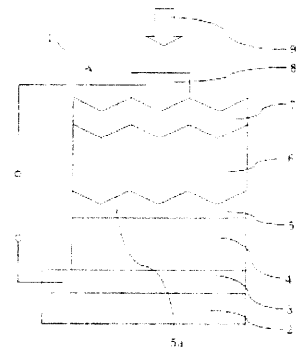

6,340,788 January 22, 2002

Multijunction photovoltaic cells and panels using a silicon or silicon-germanium cell for space and terrestrial applications

An improved photovoltaic cell has an active silicon (Si) or silicon-germanium (SiGe) substrate subcell having an active upper side and characterized by a substrate bandgap. One or more upper subcells are disposed adjacent the upper side and current matched with the substrate subcell, with the upper subcell(s) typically having bandgap(s) greater than the substrate bandgap. A transition layer may be placed intermediate the upper side and the upper subcell(s).

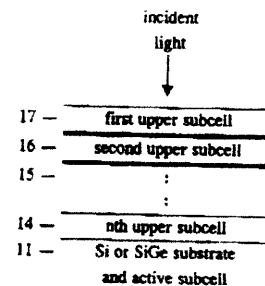

5,853,497 December 29, 1998
High efficiency multi-junction solar cells

A two-terminal voltage or current matched *solar* cell has up to four photovoltaically active junctions which efficiently convert *solar* radiation into electricity. The *solar* cell comprises GaInP, GaAs, and GaInAsP, and in the four junction case, GaInAs is used as well. The invention allows the *solar* spectrum to be converted into electricity more efficiently than previously.

5,405,453 April 11, 1995
High efficiency multi-junction solar cell

A high efficiency solar cell comprises: (a) a germanium substrate having a front surface and a back surface; (b) a back-metal contact on the back surface of the germanium substrate; (c) a first semiconductor cell comprising (1) a GaAs p-n junction formed from an n-GaAs and a p-GaAs layer, the n-GaAs layer formed on the front surface of the n-germanium substrate, and (2) a p-(Al,Ga)As window layer, the p-(Al,Ga)As window layer formed on the p-GaAs layer; (d) a tunnel diode comprising a GaAs p.sup.+ -n.sup.+ junction formed from a p.sup.+ -GaAs layer and an n.sup.+ -GaAs layer, the p.sup.+ -GaAs layer formed on the p-(Al,Ga)As window layer; and (e) a second semiconductor cell comprising (1) a (Ga,In)P p-n junction formed from an n-(Ga,In)P layer and a p-(Ga,In)P layer, the n-(Ga,In)P layer formed on the n.sup.+ -GaAs layer of the tunnel diode, (2) a p-(Al,In)P window or contact layer formed on the p-(Ga,In)P layer, (3) metal grid lines contacting either the p-(Ga,In)P layer or the p-(Al,In)P layer, and (4) at least one anti-reflection coating layer covering the (Al,In)P layer. The cascade cell of the invention permits achieving actual efficiencies of over 23%.

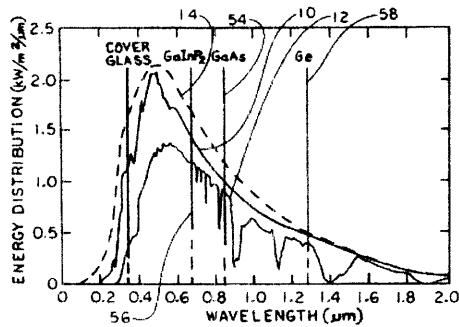

4,295,002 October 13, 1981
Heterojunction V-groove multijunction solar cell

A solar cell is disclosed with V-grooves which are series connected, but electrically isolated, indirect bandgap solar cells which are responsive to different light frequencies on both sides of a semi-insulating optically transparent substrate. The device has a very high conversion efficiency of approximately 40% and high open-circuit voltage and low series resistance. An exemplary structure in accordance with this disclosure has a series of silicon V-groove cells on one side and another series of GaAlAs V-groove cells on the other side. The cells are of generally trapezoidal cross-section. The difference between the characteristics of the Si cell and the GaAlAs cell is matched by control of the number of V-grooves.

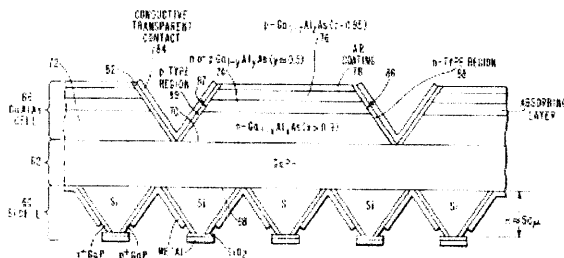

Appendix 4

Relevant Emcore patents

6,864,414 March 8, 2005

Apparatus and method for integral bypass diode in solar cells

A solar cell having a multijunction solar cell structure with a bypass diode is disclosed. The bypass diode provides a reverse bias protection for the multijunction solar cell structure. In one embodiment, the multijunction solar cell structure includes a substrate, a bottom cell, a middle cell, a top cell, a bypass diode, a lateral conduction layer, and a shunt. The lateral conduction layer is deposited over the top cell. The bypass diode is deposited over the lateral conduction layer. One side of the shunt is connected to the substrate and another side of the shunt is connected to the lateral conduction layer. In another embodiment, the bypass diode contains an i-layer to enhance the diode performance.

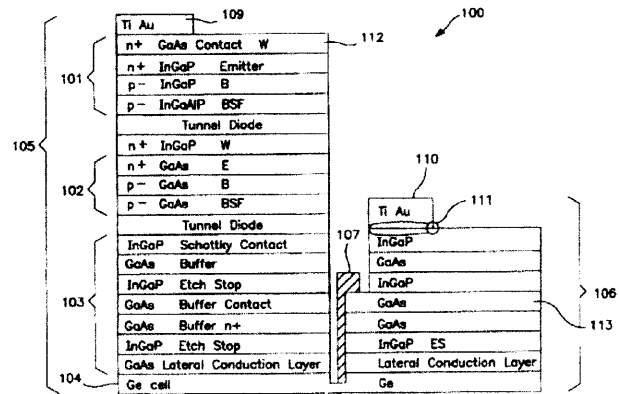

FIG. 1

6,680,432 January 20, 2004

Apparatus and method for optimizing the efficiency of a bypass diode in multijunction solar cells

Apparatus and Method for Optimizing the Efficiency of a Bypass Diode in Solar Cells. In a preferred embodiment, a layer of TiAu is placed in an etch in a solar cell with a contact at a doped layer of GaAs. Electric current is conducted through a diode and away from the main cell by passing through the contact point at the GaAs and traversing a lateral conduction layer. These means of activating, or "turning on" the diode, and passing the current through the circuit results in greater efficiencies than in prior art devices. The diode is created during the manufacture of the other layers of the cell and does not require additional manufacturing.

6,653,215 November 25, 2003

Contact to n-GaN with Au termination

A contact for n-type III-V semiconductor such as GaN and related nitride-based semiconductors is formed by depositing Al,Ti,Pt and Au in that order on the n-type semiconductor and annealing the resulting stack, desirably at about 400-600.degree. C. for about 1-10 minutes. The resulting contact provides a low-resistance, ohmic contact to the semiconductor and excellent bonding to gold leads.

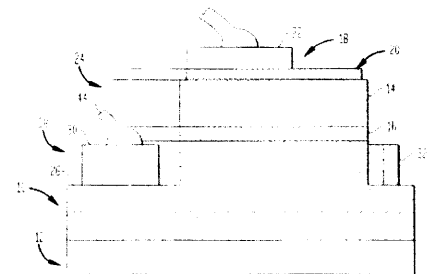

6,617,508 September 9, 2003
Solar cell having a front-mounted bypass diode

An efficient method of interconnecting a solar cell having at least two front surface contacts with a diode mounted on a front surface of the solar cell includes the act of forming at least a first recess on a front surface of the solar cell. A first solar cell contact is formed on the front surface in the first recess. A second solar cell contact is formed on the front surface. At least a first bypass diode is positioned at least partly within the recess. The bypass diode has a first diode contact and a second diode contact. The first solar cell contact is interconnected with the first diode contact. The second solar cell contact is interconnected with the second diode contact.

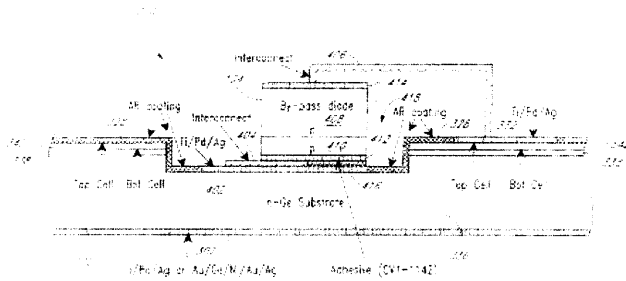

6,600,100 July 29, 2003
Solar cell having an integral monolithically grown bypass diode

The present invention is directed to systems and methods for protecting a solar cell. The solar cell includes first solar cell portion. The first solar cell portion includes at least one junction and at least one solar cell contact on a backside of the first solar cell portion. At least one bypass diode portion is epitaxially grown on the first solar cell portion. The bypass diode has at least one contact. An interconnect couples the solar cell contact to the diode contact.

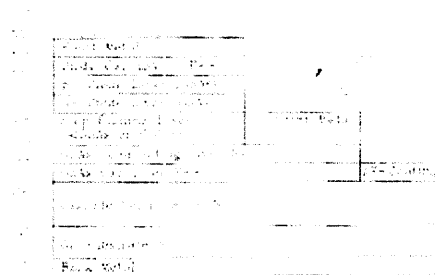

Appendix 5

Relevant Spectrolab Patents

5,508,206 April 16, 1996

Method of fabrication of thin semiconductor device

Thin semiconductor devices, such as thin solar cells, and a method of fabricating same are disclosed. A microblasting procedure is employed to thin a semiconductor wafer or substrate, such as a solar cell wafer, wherein fine abrasive particles are used to etch away wafer material through a mask. Thick areas remain at the perimeter of the semiconductor device or solar cell, in regions of the semiconductor device or solar cell behind the front interconnect attachment pads, and at corresponding rear interconnect attachment areas. In addition, there are thick areas in a pattern that comprise interconnected beams that support the thin wafer areas. Consequently, predetermined areas of the wafer are thinned to form a predetermined structural pattern in the wafer that includes an external frame and a plurality of interconnected beams. The final configuration of the semiconductor device or solar cell has approximately 20% of the area at the original wafer thickness with the remaining 80% etched away to a relatively thin thickness.

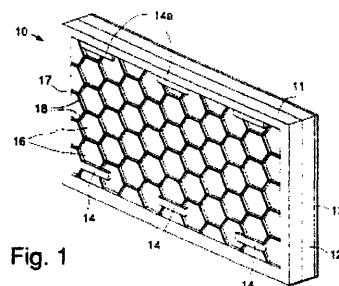

Fig. 1

5,460,659 October 24, 1995

Concentrating photovoltaic module and fabrication method

A solar cell assembly is fabricated by adapting efficient microelectronics assembly techniques to the construction of an array of small scale solar cells. Each cell is mounted on an individual carrier, which is a conventional integrated circuit (IC) package such as a dual-in-line package. Electrical connections are made between the cell and the carrier leads by automated wire bonding, followed by the emplacement of an optional secondary solar concentrator element if desired. The carriers are then automatically mounted and electrically connected to a common substrate, such as a printed circuit board, that has its own electrical interconnection network to interconnect the various cells. Finally, a primary concentrator lens assembly is placed over the array of cells. The resulting panel is thin and light weight, inexpensive to produce, allows for any desired interconnection to be made between the cells, and is capable of high conversion efficiencies.

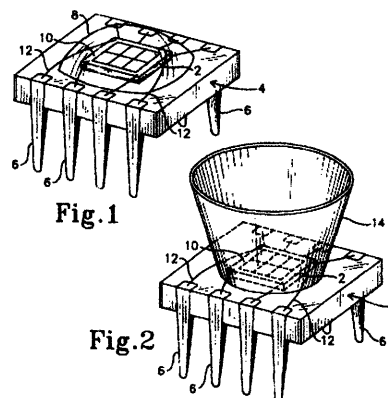

Fig. 1

Fig. 2

5,330,585 July 19, 1994

Gallium arsenide/aluminum gallium arsenide photocell including environmentally sealed ohmic contact grid interface and method of fabricating the cell

A photocell (40) includes a photovoltaic or otherwise photosensitive layer structure (44) on which a passivation or window layer (52) of an environmentally sensitive material such as aluminum gallium arsenide (AlGaAs) and an antireflection (AR) coating (54) are formed. An electrically conductive cap layer (60) delineated in a front contact grid configuration sealingly extends through the AR coating (54) to the window layer (52). An ohmic metal contact (64) is evaporated over and seals the cap layer (60) and the contiguous areas of the AR coating (54). The contact grid interface at which the cap layer (60) contacts the window layer (52) is sealed by the AR coating (54) and the contact (64). The photocell (40) is fabricated by forming, delineating and etching the cap layer (60), forming the AR coating (54) and then forming the contact (64) by evaporation of metal.

5,100,808 March 31, 1992

Method of fabricating solar cell with integrated interconnect

A pattern of current collection gridlines (24) is formed on a surface (20) of a photovoltaic wafer (12). An ohmic contact strip (28) is formed adjacent to an edge (12c) of the wafer (12) in electrical interconnection with the gridlines (24). Interconnect tabs (30) are integrally formed with the gridlines (24) and contact strip (28), extending away from the contact strip (28) external of the edge (12c) for series or parallel interconnection with other solar cells. The interconnect tabs (30) may have a stress relief configuration, including a non-planar bend or loop. The wafer (12) initially has a first portion (12a) and a second portion (12b). A barrier layer (50) of photoresist or the like is formed on the second portion (12b). The grid (24) and contact strip (28) are formed on the first portion (12a) simultaneously with forming the interconnect tabs (30) over the barrier layer (50) on the second portion (12b) using photolithography and metal deposition. The barrier layer (50) is dissolved away, and the second portion (12b) is broken away from the first portion (12a), leaving the interconnect tabs (30) extending from the contact strip (28) external of the remaining first portion (12a) of the wafer (12).

5,034,068 July 23, 1991

Photovoltaic cell having structurally supporting open conductive back electrode structure, and method of fabricating the cell

A photoresponsive layer formed of a semiconductive material such as gallium arsenide has differently doped strata which define a junction therebetween, and generates a photovoltaic effect in response to light incident on a front surface thereof. A front electrode is formed on the front surface. A structurally supporting back electrode open conductive support or grid structure is formed on a back surface of the photoresponsive layer. The support structure is sufficiently thick, approximately 12 to 125 microns, to prevent breakage of the photoresponsive layer, which may be as thin as approximately 25 to 100 microns. The support structure has a pattern selected to prevent propagation of a crack through the photoresponsive layer thereof.

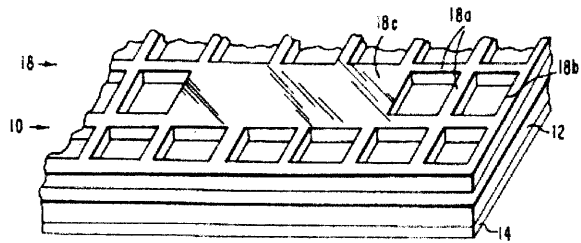

4,698,455 October 6, 1987

Solar cell with improved electrical contacts

A gallium arsenide solar cell is disclosed which employs a front aluminum gallium arsenide window layer. Metallic grid lines for charge carrier collection traverse the window layer and extend through this layer to the emitter layer. A flat conductive bar on the window layer crosses and makes electrical contact with the metallic grid lines. A flat metallic strip located on the window layer near an edge is spaced from the grid lines and conductive bar but is electrically coupled to the conductive bar by metallic bridges. Since the metallic strip is not in contact with the grid lines, external electrical connections can be affixed to the flat metallic strip using high temperature welding or soldering techniques without damage to the semiconductor body.

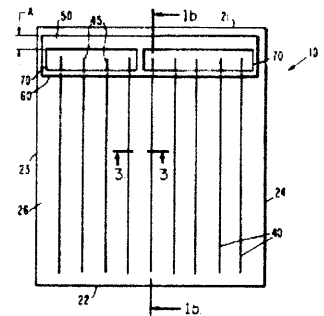

4,694,115 September 15, 1987
Solar cell having improved front surface metallization

A gallium arsenide solar cell is disclosed having an aluminum gallium arsenide window layer in which fine metallic contact lines extend through the aluminum gallium arsenide window to electrically contact the emitter layer, and a plurality of metallic grid lines disposed on the window layer cross the contact lines, thereby making electrical contact to the metallic contact lines. A flat metallic strip extending along one of the edges of the solar cell electrically couples the grid lines to one another. Consequently, two separate metals can be used, one with good ohmic contact properties for the grid lines and another with good adhesion and current conducting properties for the current collecting bars. Additionally, the metallic contacts lines can be made very narrow to reduce the contact area to the emitter thereby reducing the recombination current in the emitter.

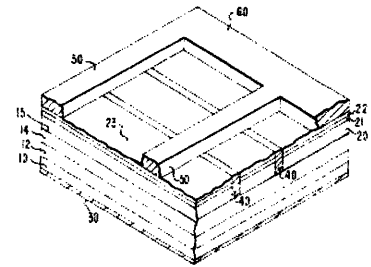

Appendix 6

Relevant Concentrator papers examined

R.R. King et. al., *Bandgap Engineering in High-Efficiency Multijunction Concentrator Cells*, International Conference on Solar Concentrators for the Generation of Electricity or Hydrogen, 1-5 May 2005, Scottsdale, Arizona. (NREL/CD-520-38172)

This paper gives the results of theoretical simulations on three and six junction solar cells and its constituent subcell materials. These simulations are done to demonstrate various solar cell architectures that are theoretically capable of reaching the 40% efficiency milestone.

Lewis M. Fraas et. al., *Towards 40% and Higher Solar Cells in a New Cassegrainian PV Module*, IEEE 2005

This paper gives an example of a solar concentrator lens structure that provides two separate cell locations to achieve near ideal efficiencies for three and four-junction cells practical. The ideal efficiency under concentration for hybrid 3J cells = 2J + 1J is 47% while the ideal efficiency for hybrid 4J cells = 2J + 2J is 52%.

G. Gabetta et. al., *SJ and TJ GaAs Concentrator Solar Cells on Si Virtual Wafers*, IEEE 2005.

A silicon substrate was used to grow Germanium using Low-Energy Plasma-Enhanced Chemical Vapor Deposition (LEPECVD), resulting in a threading dislocation density (TDD) of 10^7 cm^{-2} by etch pit counting. Single and triple junction GaAs solar cells were manufactured, their sizes ranging from 8 cm^2 down to 1 mm^2 . Reported efficiencies were within the 15% to 20% range.

Ivan Garcia et. al., *Choices for the epitaxial growth of GaInP/GaAs dual junction concentrator solar cells*, IEEE 2005

This paper analyses the different possible structures that can be grown using MOCVD for a double junction GaInP/GaAs solar cell to achieve higher than 30% efficiency. Also described in the paper is a short history of the improvements made to the dual junction solar cell over the years.

H.S. Lee et. al., *Field Test and Analysis: The Behaviour of 3-J Concentrator cells under the Control of Cell Temperature*, IEEE 2005

Kenji Araki et. al., *Development of a new 550x Concentrator Module with 3J Cells, Performance and Reliability*, IEEE 2005

This paper discusses the use of a new dome shaped Fresnel lens concentrator that is able to give 550x concentration as opposed to an older generation 400x lens. Also described is the highest reported efficiency of 38.9% at 489 suns attained using a InGaP/(In)GaAs/Ge triple junction solar cell. The total area covered with 36 solar cells at 400x concentration was 7,056 cm² and 20 solar cells at 550x concentration covering an area of 5,445 cm².

Tatsuya Takamoto et. al., *Future Development of InGaP/(In)GaAs based Multijunction Solar Cells*, IEEE 2005

This paper describes the use of thin film technology developed by Sharp Corporation as a means to lowering material cost whilst maintaining device performance. Advantages of this technology include maintaining the high efficiency of multijunction solar cells whilst having high flexibility, lightweight, back metal reflection for better light confinement, high radiation resistance and possibility of substrate reuse.

Sherif Michael and Max Green, *The Modeling, Design and Optimization of Multi-Junction Photovoltaic Devices*, IEEE 2004

This paper primarily discusses the simulation of multijunction solar cells. It gives a schematic drawing of the various materials, thicknesses and doping levels used in a four junction solar cell.

F. Dimroth et. al., *5-Junction III-V Solar Cells for Space Applications*, 3rd World Conference on Photovoltaic Energy Conversion, May 11-18, 2003, Osaka, Japan

This paper characterizes a five-junction solar cell comprising of AlGaInP, GaInP, AlGaInAs, GaInAs and Ge subcells. Highlighted therein is the difficulty of measuring the individual subcell efficiencies, and an accurate characterization combined with a theoretical simulation of the layer properties.

A.W. Bett et. al., *Flatcon™ Modules: Technology and Characterization*, 3rd World Conference on Photovoltaic Energy Conversion, May 11-18, 2003, Osaka, Japan

This paper describes the use of Fresnel Lens All-glass Tandem-cell Concentrator modules with dual junction GaInP and GaInAs solar cells. The advantage prescribed to using these concentrator modules is that the solar cell area can be reduced.

Tatsuya Takamoto et. al., *Multijunction Solar Cell Technologies – High Efficiency, Radiation Resistance, and Concentrator Applications*, 3rd World Conference on Photovoltaic Energy Conversion, May 11-18, 2003, Osaka, Japan

In this paper, several improvements to the InGaP/(In)GaAs/Ge triple junction solar cell were discussed. These include the inclusion of double-hetero wide bandgap tunnel junctions, as well as precise lattice matching with the Ge substrate through the addition of 1% Indium into the GaAs subcell amongst others.

H. Cotal et. al., *Outdoor Operation of GaInP/GaAs/Ge Triple Junction Concentrator Solar Cells up to 1000 Suns*, 3rd World Conference on Photovoltaic Energy Conversion, May 11-18, 2003, Osaka, Japan

This paper discusses the experimental results from outdoor testing of GaInP/GaAs/Ge triple junction under concentrated sunlight. An interesting observation highlighted is that the solar cells do not fail even under a concentration of 1000 suns.

R.R. King et. al., *High-Voltage, Low-Current GaInP/GaInP/GaAs/GaInNAs/Ge Solar Cells*, IEEE 2002

Discussion of the inclusion of a new material, GaInNAs into a four junction solar cell for better division of the solar spectrum to ease current matching requirements. This paper proposes a five junction solar cell composed of two GaInP cells, and one Ga(In)As, GaInNAs and Ge cell each.

Appendix 7

Sharp Corporation

Sharp Corporation identifies solar energy as an increasing essential component of our lives in the years ahead. This is substantiated in the light of declining fossil fuel supplies worldwide as compared to the inexhaustible availability of solar energy.

(Remaining Fossil Fuel Supply in Number of Years and Extractible Volume)

Fossil Fuel	Petroleum	Uranium	Natural Gas	Coal
Runs out in (Date of estimate)	39.9 years (2001)	64.2 years (1999)	61 years (2001)	227 years (2001)
Extractible volume	1,046 billion barrels	3.95 million tons	150 trillion cubic meters	984 billion tons

Solar energy is clean and inexhaustible!

The three reasons given for the utilization of solar energy now are:

- 1) limitless energy from the sun
- 2) no module noise or CO₂ emissions
- 3) no energy distribution infrastructure required

<p>Limitless Supply of Energy from the Sun</p> <p>The amount of energy released by the sun in one hour is equivalent to the power consumption of the Earth for an entire year.</p> <p style="text-align: center;">▼</p> <p>No worries about depletion.</p>	<p>No Module Noise or Carbon Dioxide Emissions</p> <ul style="list-style-type: none"> • Installing a 3 kW system in each of Japan's approximately 2.3 million detached houses would result in clean power production of about 70 billion kWh annually. • Each kW home system reduces carbon emissions by 540 kg annually (in comparison with oil-fired power generators).
---	--

Solar Power Generation

No Energy Distribution Infrastructure Needed

Solar power generation systems make effective use of roof space to convert solar energy into electricity for household use. Excess electricity produced during daylight hours can even be sold to the electric company! Fully electrified households can save even further on lighting costs with an economical hourly demand lighting contract in Japan.

For Sharp Corporation, the large majority of the solar cells manufactured are utilized in residential applications for providing energy to households in Japan.

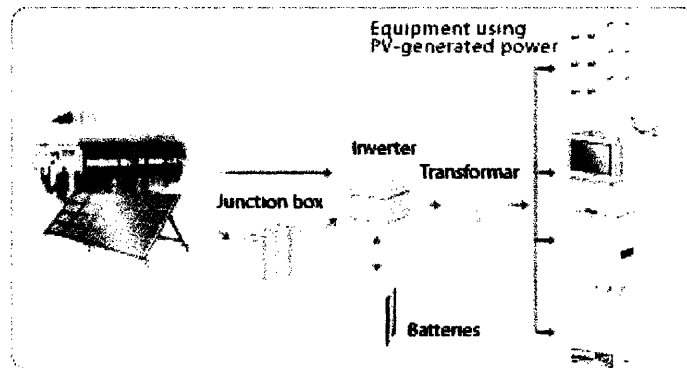

Besides on-grid solar power generation, stand-alone off-grid applications such as power generation for either entire villages, public amenities as well as individual homes are also the target market for Sharp solar cells.

Sharp Corporation has been the world’s leading manufacturer of solar cells and modules for four consecutive years, providing almost 27.1% of the world’s total solar cell and module production.

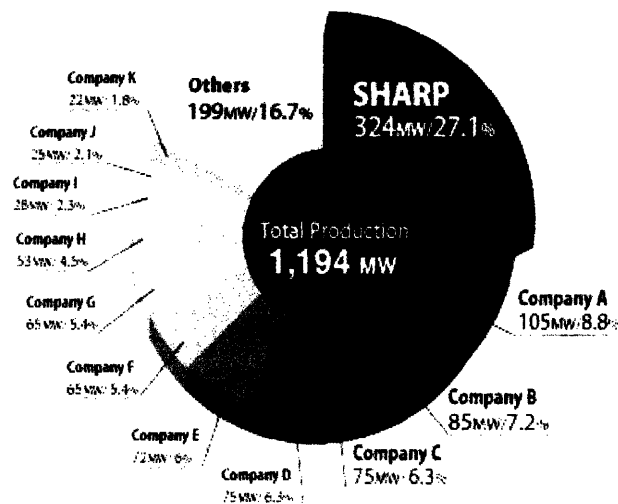

The production volume of Sharp Corporation has steadily increased over the years, from 150 MW in 2002 to 400 MW in the year 2005. Also the company has production facilities in Europe as well as in Memphis, Tennessee. Sharp Corporation is also actively involved in initiatives to save the environment, and hopes that the utilization of solar energy will help stop global warming and preserve fossil fuel supplies. Sharp is also involved in the research of thin film solar cells comprising of III-V multijunction solar cells on a metal thin film as well as mass production of polysilicon solar cells for residential use.

Reference: <http://sharp-world.com/solar/index.html>

Appendix 8

Companies involved in different solar cell technologies

Polycrystalline Si

Sharp Corp., Kyocera, BP Solar, Photowatt, Misawa Homes (BP), MSK Corp. (BP)
Tokuyama Corp., Motech Solar, Q-Cells AG, Green Energy Tech. (GT), Shell Solar
LDK Solar Hi-Tech Co. (GT), Solar World AG, Baoding Yingli New Energy Resources
Nanjing PV-Tech Co., RWE-Schott Solar, ErSol Solar Energy AG, Sunways AG
Photovoltech, Wacker Polysilicon Renewable Energy Corp., AS PV Silicon AG

Amorphous Si

SANYO Electric, Kaneka Solartech, Mitsubishi Heavy Industries, Canon
Fuji Electric Systems, Daiwa House, Sinonar Corp., United Solar Systems
RWE-Schott Solar, UNAXIS Solar

Single crystal Si

Hitachi, Isofoton, Q-Cells AG, E-TON Solartech, Photowatt, GE Energy
Suntech Power, Nanjing PV-Tech Co., Shanghai Solar Energy Sci. & Tech.
BP Solar, Shell Solar, Evergreen Solar, ErSol Solar Energy AG, Photovoltech
PV Silicon AG

II-VI solar cells

Honda
Matsushita Ecology Systems
Showa Shell Sekiyu
BP Solar Shell Solar
First Solar LLC
Würth Solar GmbH
ANTEC Solar Energy AG

Appendix 9

Kyocera Corporation

Kyocera Corporation began operations in 1959 initially as a startup venture by Dr. Kazuo Inamori and his seven colleagues. Ten years later, the company expanded into North America and eventually grew to become the second largest PV manufacturer worldwide. The company primarily deals with the manufacture of polycrystalline silicon solar cells for various residential as well as industrial applications. In 1996, solar cells which achieved 17.1% energy conversion efficiency were developed. This was a world record at that time for solar cells which had an area of 225 cm² (15 cm x 15 cm). Today, Kyocera is working to create more efficient, lower-priced solar cells with a larger surface area and reduced thickness by further developing the multicrystalline silicon solar cell technology.

Reference:
<http://www.kyocerasolar.com/about/timeline.html>

Arnulf Jäger-Waldau, PV Status Report 2005, European Commission, DG JRC, Institute for Environment and Sustainability, Renewable Energies Unit via Enrico Fermi 1; TP 450 I – 21020 Ispra, Italia, EUR 21836 EN

Sanyo Electric Company

The most captivating feature of Sanyo Electric Company is the huge Solar Ark inspired by the vision of an ark embarking on a journey towards the 21st century. Sanyo Electric Company began manufacturing amorphous silicon solar cells in 1975. Moving on, in 1997, HIT (Heterojunction with intrinsic thin layer) solar cells were marketed. These hybrid solar cells are created by combining amorphous and crystalline silicon together using an intrinsic semiconductor. In 2003, a 200 W photovoltaic module was marketed which held the record then for highest conversion efficiency at 19.5% for individual cells and 17.0% for each module. These cells were mass produced at the Nishikinohama plant. Two years later in 2005, a manufacturing facility in Hungary was built producing these HIT solar cells.

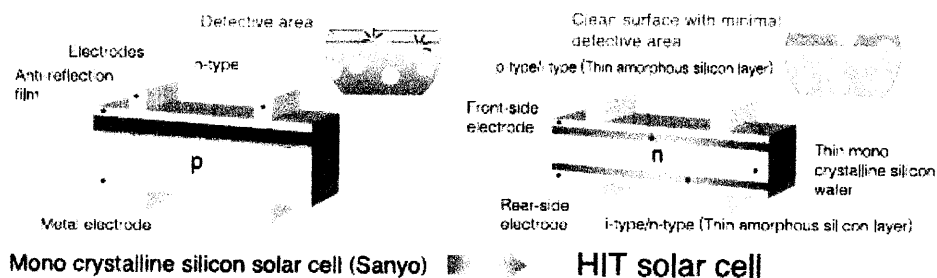

Development of HIT solar cell was supported in part by NEDO
 (NEDO: New Energy and Industrial Technology Development Organization)

Two advantages of the HIT solar cell stated were that the very high conversion efficiency of HIT photovoltaic modules makes it possible to install more capacity compared to other conventional crystalline photovoltaic modules, and that even at high temperatures; the HIT solar cell can maintain higher efficiency than a conventional crystalline silicon solar cell. The highest cell and module efficiencies quoted were 19.3% and 17.2% respectively. The latest expansion plans foresee a rapid expansion to 250 MW in 2006 and 1000 MW in 2010.

References:

http://www.sanyo.co.jp/clean/solar/hit_e/index_e.html

Arnulf Jäger-Waldau, PV Status Report 2005, European Commission, DG JRC, Institute for Environment and Sustainability, Renewable Energies Unit via Enrico Fermi 1; TP 450 I – 21020 Ispra, Italia, EUR 21836 EN

Mitsubishi Electric

Mitsubishi Electric is dedicated to promoting solar power systems as an indispensable source of clean energy for the future. Photovoltaic (PV) modules, which comprise the core of the technology, drew much attention in Kyoto, Japan in December 1997, at the Third Session of the Conference of the Parties to the U.N. Framework Convention on Climate Change (COP3), generally referred to as "The Kyoto Protocols."

This company began operations in 1974, and a short two years later expanded into the space satellite business. Since then, production has steadily grown from 25 MW in 2001 to 135 MW in 2005. A large emphasis is also placed on the inverter unit, which converts the DC PV output into AC power for household appliances. This year, in 2006, Mitsubishi Electric commences the sales of 95.5% efficient inverters which are the highest in the industry. Mitsubishi PV systems are developed and manufactured at Nakatsugawa Works, located near the center of Japan. Cells are manufactured at Iida factory and modules are manufactured at both Iida factory and Kyoto factory. Iida factory and Kyoto factory are branches to Nakatsugawa Works.

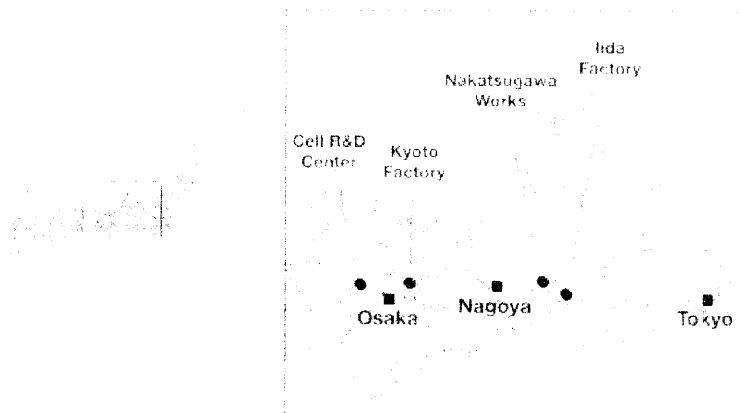

Mitsubishi Electric PV modules are made from polycrystalline silicon and have an efficiency that ranges from about 12.7 to 13.5%.

References: <http://global.mitsubishielectric.com/bu/solar/index.html>

Kaneka Corporation

Kaneka has been involved in the development of amorphous solar cells for 25 years. The aim of the company was to mass produce amorphous silicon modules for rooftop applications. The company website discusses several reasons to choose amorphous silicon over crystalline or polycrystalline silicon. Firstly, crystalline and polycrystalline silicon lose some of their power-generating capability with temperature rise. Also, a single amorphous silicon layer can be made extremely thin (0.3 μm) as compared to crystalline silicon modules which are usually 200 μm thick. This translates to less material required and thus a shorter energy payback time of 1.6 years as compared to 2.2 years for polycrystalline silicon. However, these amorphous silicon solar cells average a conversion efficiency of only about 10.5%.

An interesting product offered by Kaneka is the 10% transmittance PV module that allows some light to pass through. This has been successively introduced to shelter pedestrian walkways whilst providing electricity for public facilities. Kaneka Corporation has a current manufacturing facility producing 30 MW per year of thin film solar modules at the Toyooka factory and is expected to expand to 55 MW in 2007.

References:

<http://www.pv.kaneka.co.jp/>

Arnulf Jäger-Waldau, PV Status Report 2005, European Commission, DG JRC, Institute for Environment and Sustainability, Renewable Energies Unit via Enrico Fermi 1; TP 450 I – 21020 Ispra, Italia, EUR 21836 EN

Mitsubishi Heavy Industries

Similar to Kaneka Corporation, Mitsubishi Heavy Industries (MHI) is also involved in the manufacture and sales of amorphous silicon solar cells. Also described on the company website are the reasons for subscribing to amorphous silicon – lower temperature dependence, reduced material requirements and can be shaped to fit any installation site. MHI uses plasma CVD deposition to rapidly deposit on large glass and flexible substrates (roll to roll). The efficiency of these amorphous silicon cells are about 8%, and MHI is working on improving this figure to 12% through the use of microcrystalline / amorphous structure.

References:

http://www.mhi.co.jp/power/e_a-si/index.html

Arnulf Jäger-Waldau, PV Status Report 2005, European Commission, DG JRC, Institute for Environment and Sustainability, Renewable Energies Unit via Enrico Fermi 1; TP 450 I – 21020 Ispra, Italia, EUR 21836 EN

Canon

Canon developed a triple junction a-Si/a-SiGe/a-SiGe solar cell with an efficiency of about 13.5%. This was announced at the 3rd World Conference on Photovoltaic Energy Conversion in Osaka, May 2003. Subsequently, to market this technology, Canon collaborated with Energy Conversion Devices, Inc. to form United Solar. The spectrum splitting cell comprises of three separate PIN type amorphous silicon subcells, each with a targeted response to blue, green and red light. Through the use of roll-to-roll deposition, less material and energy is required than crystalline solar cells.

Roll-to-Roll Deposition

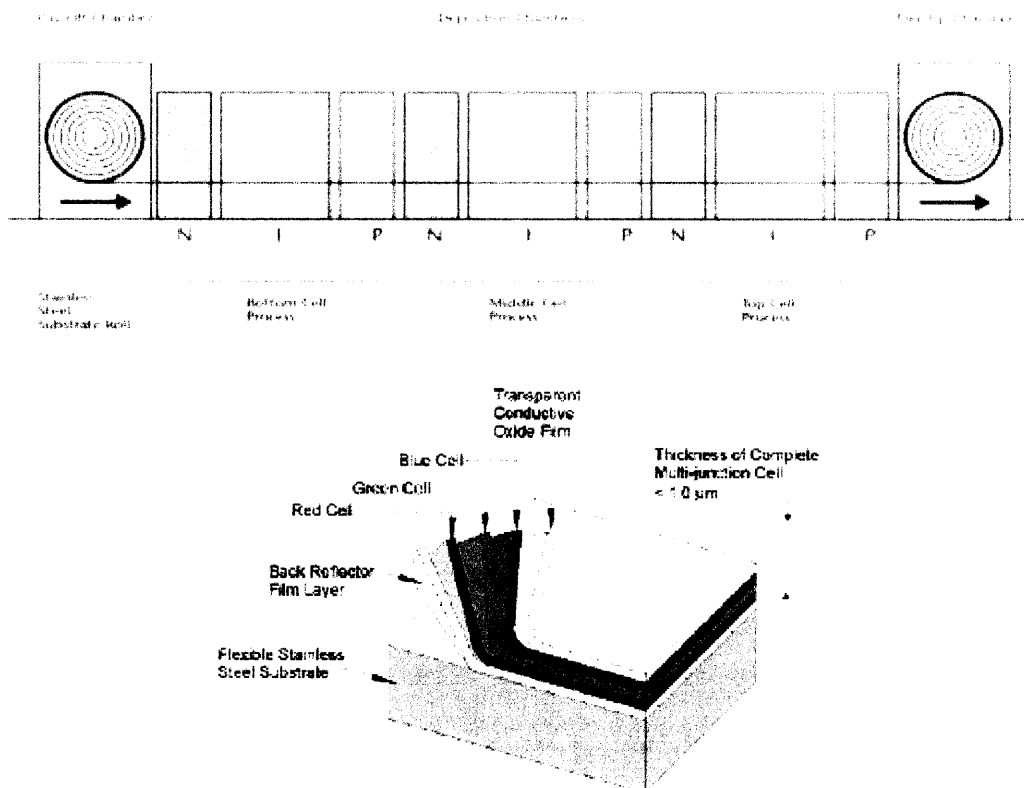

Reference: http://www.unlimited-power.co.uk/Unisolar_panels.html

MSK Corporation

MSK Corporation was established on the first of July, 1967. In 1992, MSK sealed a distribution agent contract with Solarex (now BP Solar), the world's largest manufacturer of polycrystalline solar cells. Subsequently in 2003, the production capacity increased to 100 MW in Nagano factory, the largest single module manufacturing plant in the world. A year later, an 80 MW plant was built in Omuta City, Fukuoka Prefecture. MSK manufactures monocrystalline, polycrystalline and amorphous silicon solar modules from different cell manufacturers. Since its establishment, the company has expanded to a total of 350 employees with annual sales of 22 billion yen (year ended June 2005).

References: <http://www.msk.ne.jp/en/outline.shtml>

Daiwa House

Daiwa House was established on the 5th of April, 1955, specializing in the building of pre-fabricated houses. A major turning point came in 1977 when the first “Daiwa House Solar DH-1” house was introduced which that utilized solar power to save on electricity. Since August 1998, Daiwa House has been selling “Whole-Roof Solar Energy System” attached to single family houses. The solar cells used are made from amorphous silicon.

References:

<http://www.daiwahouse.co.jp/English/>

Arnulf Jäger-Waldau, PV Status Report 2005, European Commission, DG JRC, Institute for Environment and Sustainability, Renewable Energies Unit via Enrico Fermi 1; TP 450 I – 21020 Ispra, Italia, EUR 21836 EN

Sekisui Heim

Sekisui Heim is the housing division of the Sekisui Chemical Company, which was founded in 1947 to build modular houses. In January 2003, Sekisui introduced the “zero-cost-electricity-system” where the utility charges are ideally zero due to the introduction of solar energy conversion. These houses utilize a 5.5 kW solar energy generation system and insulated walls to reduce heating or cooling costs. In 2004, Sekisui sold 7,060 houses equipped with PV systems or 52% of its new houses sales and an additional 2,150 PV systems for existing houses.

References:

Arnulf Jäger-Waldau, PV Status Report 2005, European Commission, DG JRC, Institute for Environment and Sustainability, Renewable Energies Unit via Enrico Fermi 1; TP 450 I – 21020 Ispra, Italia, EUR 21836 EN

The Japan Times, 16 April 2003

<http://www.japantimes.co.jp/cgi-bin/getarticle.pl5?nb20030416a7.htm>

Osamu Ikki, PV Activities in Japan, Volume 11. No 6, June 2005

Tokuyama Corporation

Tokuyama is a chemical company involved in the manufacturing of solar grade silicon for solar cells. The company is one of the world's leading polysilicon manufacturers and produces roughly 20% of the global supply of electronics and solar grade silicon. In October 2005, Tokuyama increased the production volume by 400 tons, from 4,800 to 5,200 tons at its Tokuyama Higashi Plant (Shunan, Yamaguchi).

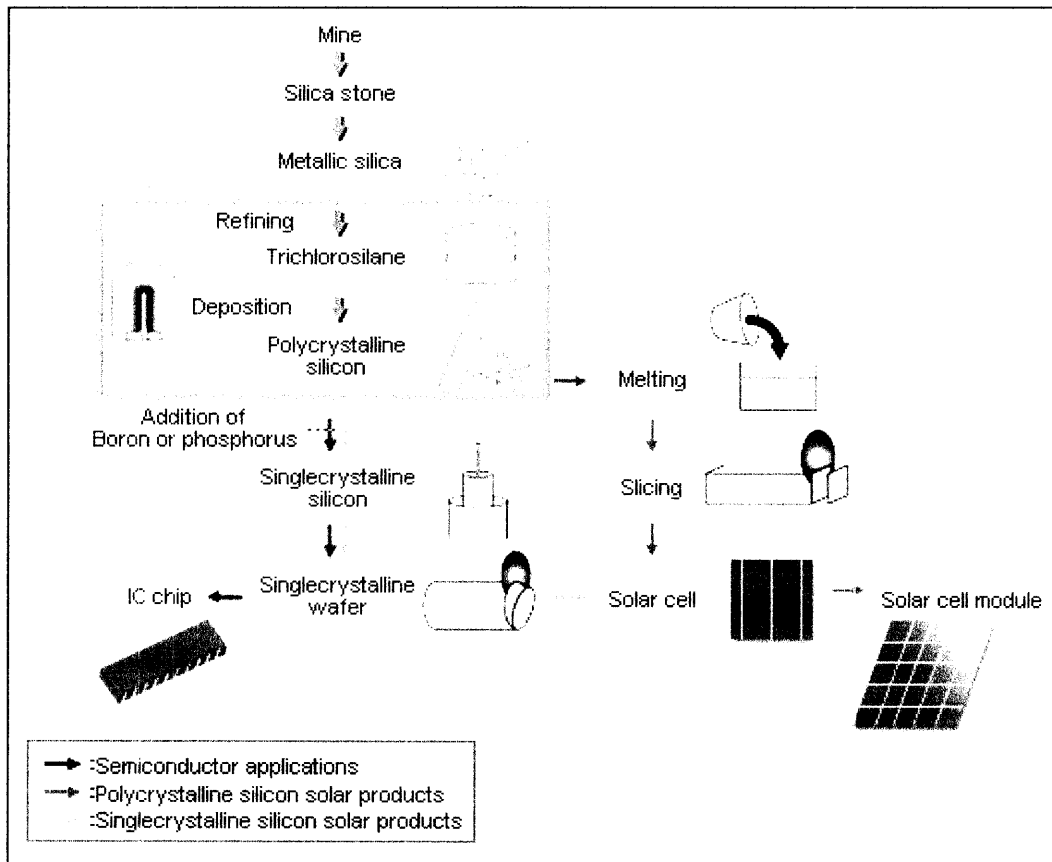

References:

Arnulf Jäger-Waldau, PV Status Report 2005, European Commission, DG JRC, Institute for Environment and Sustainability, Renewable Energies Unit via Enrico Fermi 1; TP 450 I – 21020 Ispra, Italia, EUR 21836 EN

Appendix 10

Motech Solar, Taiwan

Dr. Yuan-Huai Simon Tsuo is the CEO of Motech Solar, which is located in the prestigious South Taiwan Science Park. Motech Solar is the first manufacturer in Taiwan that specializes in the production of crystalline silicon solar cells. Presently, Motech Solar's main products are multi- and mono-crystalline silicon solar cells with the dimension of 125-mm x 125-mm and 156-mm x 156-mm. The average production solar cell efficiencies are higher than 15.5% and 16.5% for multi- and mono-crystalline silicon solar cells, respectively. Motech Solar has a production capacity of 120 MWp/year as of the end of 2005. One of Motech Solar's goals is to become the lowest-cost solar cell manufacturer in the world.

Reference: <http://www.motechind.com/english/Incorporation1/index.asp>

Sinonar Corporation, Taiwan

Sinonar Corporation is the first and foremost company in Taiwan engaged in research, development and manufacture of amorphous silicon devices. The expansion of factory building and the addition of solar cell production equipment in 1994 resulted in a total plant area of 14,200 square meters and an annual production capacity of over 3 million peak watts. Sinonar is aiming to become a full-line producer in solar cells, panels, modules and photovoltaic systems for both indoor and outdoor applications. According to Wisely Chen, sales manager of the solar cell department, the company aimed to increase its production to 5 MW in 2004. In addition, they set up a joint-venture production facility in the PRC. The planned capacity at the first stage is 10 MWp.

Reference: <http://www.sinonar.com.tw/>

E-TON Solartech Co. Ltd., Taiwan

E-TON Solar Tech focuses on developing solar cells to promote green and renewable energy in order to help reduce the problems associated with energy consumption and the green house effect. The company receives several subsidies from the government of Taiwan. The "Small Business Innovation Research (SBIR) Project" and the "Project for industrial technology improvement and personnel training" sponsored by the National Science Council are examples of such government funded programs. To further develop their technologies, E-TON Solar Tech has actively cooperated with the Industrial Technology Research Institute (ITRI), the National Cheng Kung University (NCKU), and Southern Taiwan University of Technology (STUT). The current production output is 25 MW per annum and the expected capacity will reach 60 MW after expansion is completed. E-TON Solar Tech strives to be one of the Top Mono-crystalline Solar Cell Providers and will continue to serve as a green energy pioneer in the world, and provide safe, reliable, and clean energy, which will benefit the society and the next generation.

Reference: <http://www.e-tonsolar.com/company.htm>

Green Energy Technology, Taiwan

Green Energy Technology is a newly formed subsidiary in the Tatung Group of companies in Taiwan. The current production capacity is at 25MW of solar panels per year, with room for expansion to several hundred MW. GT Solar Technologies will install a turnkey multi-crystal silicon wafer manufacturing line at Green Energy Technology Inc that features its new DSS series of multi-crystal ingot growth furnaces.

Reference: GT Solar Technologies, Press Release, 4 August 2004
<http://www.gtequipment.com/news/shownews.php?id=27>

Suntech Power Co. Ltd, PRC

Suntech Power Co. Ltd was founded by Dr. Zhengrong Shi, a student of Prof. Martin Green from the University of New South Wales, Australia. In Dec 2002, Suntech power Co. Ltd signed a cooperation agreement with the Center of Excellence for Photovoltaic Engineering at the University of New South Wales in Australia. In March 2005, PHOTON International, the leading magazine for the international PV industry, ranks Suntech as the largest manufacturer of PV cells in China and one of the top ten in the world based on production output in 2004. Three months later in June 2005, Suntech completed building its fourth and fifth manufacturing lines, which brought its annualized manufacturing capacity to 120MW. The vision of Suntech Power Co. Ltd is to become one of the world's largest solar energy providers by producing low cost per watt solar solutions through ongoing investment in R&D combined with low-cost China-based manufacturing. The products are mono- and multi-crystalline silicon solar cells.

Reference: <http://www.suntech-power.com/en/qywh.html>

Tianwei Yingli New Energy Resources Co., Ltd, PRC

Yingli Solar strives for the protection of the environment, and is committed to bringing cost-effective, quiet, attractive, safe and reliable solar electricity to its consumers. The company is active across the entire value chain of photovoltaics, from the manufacture of silicon ingots to the sale of complete modules. These modules are utilized in various on-grid and stand-alone applications such as public lighting. The silicon ingots and subsequent solar cells produced are polycrystalline, with a conversion efficiency of about 15.5%.

The company has also been involved in the largest photovoltaic project in China, the National Brightness Project, and has built several photovoltaic power stations in the Sichuan and Qinghai Provinces. Currently in its third phase of expansion, Yingli Solar is expanding the current production volume from its current 95 MW for wafers, 60 MW for solar cells and 100 MW for complete modules. At a cost of 3 billion RMB, the third phase will finish in 2008, and be capable of producing 500 MW of ingots, solar cells and complete modules each. The expected annual

revenue is 16 Billion RMB after the third phase of expansion. The company will also be building a solar research facility in collaboration with other companies.

Reference: <http://www.yinglisolar.com/en/news/news.html>

Shanghai Chauri Solar Energy Science and Technology Development Co. Ltd.

The company specializes in the production of monocrystalline and polycrystalline solar cells as well as complete systems in accordance to the international IEC1215.GB/T9535 standard.

Reference: <http://www.super-solar.com/x1.htm>

Nanjing PV-TECH Co. Ltd.

Nanjing PV-TECH started as a joint venture between the Chinese Electrical Equipment Group (CEEG) in Jiangsu as well as a group of Australian Solar experts. The company was formed with an initial registered capital of US\$10.8 million, with the total investment at the first stage being US\$ 30 million. The total design production capacity target is 600 MW with a total output value of 15 billion RMB by the year 2008. Beginning in June 2005, the first production lines began operation with a capacity of approximately 30 MW per year, increasing up to 100 MW per year by the end of 2005. The company is headed by Dr. Zhao Jianhua who has been credited with some of the highest conversion efficiencies known today for monocrystalline and polycrystalline solar cells at 24.7% and 19.8% respectively. Dr. Zhao is also an Associate Professor at the University of New South Wales in Australia, the university with which Nanjing PV-TECH has a strategic partnership with. The backing of the company is also strong, as the CEEG group controls 8 other subsidiary companies, 1 R&D center, 2 research institutes staffed by over 2000 employees. The company sells monocrystalline and polycrystalline solar cells with efficiencies of > 17% and ~16% respectively.

Reference: <http://www.njpv-tech.com/>

LDK Solar Co. Ltd.

Jiangxi LDK Solar Hi-Tech Co. Ltd. is joint venture between Hong Kong Liouxin Industrial Co. Ltd. and Suzhou Liouxin Industrial Co. Ltd. and has its manufacturing facility based in Xinyu City in Jiangxi Province. With an initial investment of \$72.5 million RMB, the expected production output is at 100 MW per year by 2006 with a retail value of 800 million RMB. This value is expected to reach a total of 15 billion RMB at a production output of 1 TW by the year 2010. LDK Solar is also currently collaborating with GT Solar (USA) to form a joint laboratory with Shanghai Jiaotong University for continued research and development. The company specializes in the production of polycrystalline silicon wafers using equipment from manufacturers throughout USA, Europe and Japan.

Reference: <http://www.ldksolar.com/english/index.html>

Appendix 11

BP Solar

BP Solar is committed to bringing cost effective and clean energy solutions to the world, and offers modular solar homes as well as separate PV systems for its customers. BP Solar has four major manufacturing facilities in Spain, Australia, USA and India. BP entered the solar industry in 1980 with the acquisition of Lucas Energy Systems and began production of polycrystalline silicon solar cells. Since then BP Solar has increased its production capacity to 200 MW in the year 2006 and works with key institutions such as the Fraunhofer Institute in Germany and Northwestern University in the US to research potential solar technologies for the future. Currently, BP Solar produces not only monocrystalline and polycrystalline solar cells, but is also involved in the entire production cycle from silicon ingot to complete module delivery.

References: <http://www.bp.com/modularhome.do?categoryId=4260>

Shell Solar

Shell Solar believes in the advancement of Copper Indium Diselenide (CIS) thin film technology as a means of achieving affordable solar power. CIS thin film technology has advantages in that it has a simpler production process, limited breakage probability as well as low cost as compared to its silicon counterparts. Shell Solar, like BP Solar is active across the whole field of photovoltaics, from wafer production to complete module sales. The distinguishing factor as mentioned above is that Shell Solar is also involved in the development of CIS thin film technology. CIS solar cells sold have a record 13.5% efficiency and have received several awards from the US Department of Energy as well as the US R&D award in 1999. Whole Solar modules have efficiencies ranging from 9.3% for the CIS solar cells to 13.3% and 12.5% for monocrystalline and polycrystalline solar cells respectively.

Reference:

<http://www.shell.com/home/Framework?siteId=shellsolar>

GE Energy

GE Energy produces polycrystalline solar cells and sells individual solar cells as well as complete modules to its customers. GE Energy has been in the business of selling solar cells for over 25 years, and was recently requested to provide 150 kW of solar modules for a new solar power installation in Korea in March 2006. The company is also dedicated to the advancement of solar technology through its *Ecoimagination* programme which invests US\$1.5 billion annually into research in cleaner technologies by 2010. Based in Atlanta, Georgia, GE Energy does not only deal with solar power but also other forms of renewable energy as well such as wind and hydroelectric power.

Reference: http://www.gepower.com/prod_serv/products/solar/en/index.htm

United Solar Ovonix

United Solar Ovonix, LLC has its headquarters in Auburn Hills, Michigan. It is the world's largest manufacturer of triple junction amorphous silicon solar panels. The company is a subsidiary of Energy Conversion Devices (ECD Ovonix) and manufactures flexible thin film solar cells. The annual production capacity of the current manufacturing plant is 25 MW and will be doubling in size by the fall of 2006. The company will be expanding its operations with the building of a new manufacturing facility in Greenville, Michigan which will add an additional 50 MW capacity by the end of 2007. United Solar hopes to expand to 300 MW by the year 2010 and has an established distributor network as well as original equipment manufacturer network in place around the world. The multijunction silicon solar cell is created with separate amorphous silicon and 2 silicon-germanium cells.

Reference:

<http://www.uni-solar.com/>

http://www.uni-solar.com/uploadedFiles/0.4.2_white_paper_4.pdf

First Solar

First Solar is one of the few companies worldwide to manufacture CdTe solar cells. This material is derived from cadmium used from zinc smelting waste, and this helps to reduce the amount of toxic cadmium entering the environment. First Solar is one of the fastest growing solar module manufacturers worldwide, producing ~20 MW per year as of 2005. The company has also launched a project to triple current annual production to 75 MW, making it the largest thin film PV manufacturer in the world. It also has the industry's first comprehensive environmental product life cycle program to encourage end-of-life recycling. The CdTe solar cells that it sells has an average module efficiency of 9%. CdTe as a material is abundantly found in mining waste, and is a direct bandgap semiconductor for efficient photovoltaic conversion.

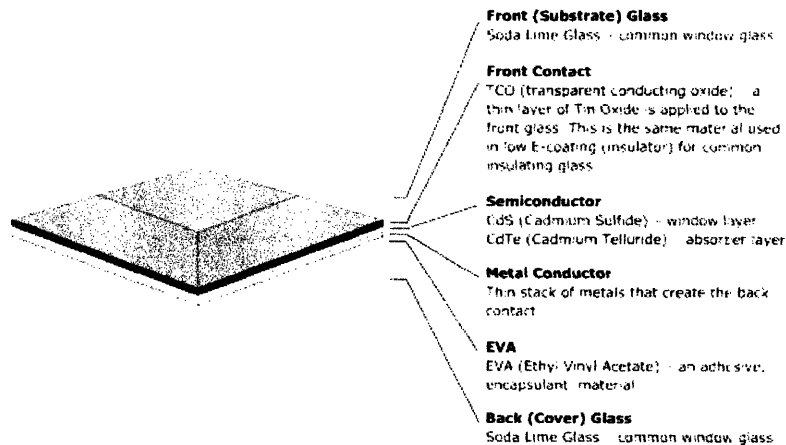

Reference: <http://www.firstsolar.com/>

Appendix 12

Isofoton

Isofoton is a Spanish company founded by Professor D. Antonio Luque of the Polytechnic University of Madrid. The company has a new facility in Malaga which was completed in 2005 that increased its manufacturing capacity from 65 MW to over 100 MW. In 2004, Isofoton was the third largest manufacturer of solar cells in Europe and the 9th largest worldwide at 53.3 MW. Isofoton sells monocrystalline silicon solar cells and modules, and is actively involved in the development of flat panel concentrator systems utilizing GaAs solar cells.

References:

http://www.energyoutfitters.com/default.htm?http://www.energyoutfitters.com/products/solar_panels/isofoton.shtm

Arnulf Jäger-Waldau, PV Status Report 2005, European Commission, DG JRC, Institute for Environment and Sustainability, Renewable Energies Unit via Enrico Fermi 1; TP 450 I – 21020 Ispra, Italia, EUR 21836 EN

RWE-Schott Solar

In 1959, AEG Telefunken began developing photovoltaic systems for space travel. In 1973, the Edge-Defined, Film-Fed Growth (EFG) process was developed for the manufacture of monocrystalline solar cells. Seven years later in 1980, the amorphous silicon solar cells were developed comprising of two amorphous silicon solar subcells. Over the years, in the year 2002, the RWE-Schott Solar joint ventures were established along with RWE Space Solar Power GmbH, and production begins at the Smart-SolarFab® facility in Alzenau. The facility grew to a production capacity of 100 MW, and a 40 MW module production facility was setup in the Czech Republic. Last year in 2005, Schott AG, Mainz took over the operations and the production capacity was further increased to 130 MW.

Schott Solar uses its proprietary EFG process to saw the silicon wafers in order to minimize material wastage. The efficiency of the polysilicon MAIN (Multi-crystalline Advanced Industrial Cells) solar cells has a maximum efficiency of 15.1%. The EFG process solar cells on the other hand have a lower maximum average efficiency of 14.5%.

Reference: <http://www.schott.com/photovoltaic/english/index.html>

Q-Cells AG

Q-Cells is the largest independent manufacturer of solar cells. Q-cells AG was founded at the end of 1999 and only began production of solar cells in 2001 with 19 employees and has grown exponentially to become the second largest solar cell manufacturer in the world and recently opened a sales office in Hong Kong. This translates to a production capacity of 165.7 MW in 2005 from the initial 0.4 MW in 2001. Also in September 2004, production line IV was initiated with a capacity of 180 MW. This should be completed by mid 2006 to boost production capacity to 350 MW.

Q-Cells has also many research partners such as the Hahn Meitner Institute (HMI), the Energy Research Centre of the Netherlands, the Fraunhofer Institute of Solar Energy Systems (ISE), Hameln Institute of Solar Research (ISFH), the University of Constance, and the Julich Research Centre. Current research topics that Q-cells is engaged in include efficiency increase, ultra-high performance solar cells, thin-film methods as well as novel methods in polysilicon production and contact formation.

Q-cells manufactures monocrystalline and polycrystalline solar cells with efficiencies of >16% and > 14.1% respectively.

Reference: http://www.q-cells.com/cmadmin_2_474_0.html

Solar World AG

Solar World AG was founded in 1998. Since then, the former trading company has developed into a fully integrated solar company dealing from raw silicon material to high quality solar power generating systems. Other companies within the group are:

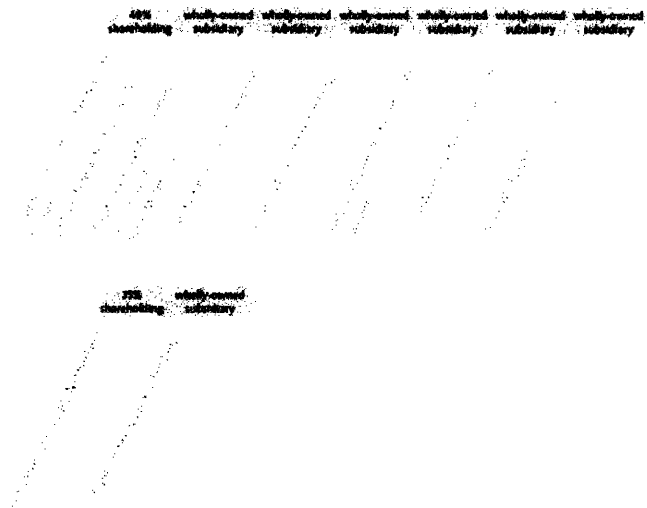

In 2003, the Solar World group was the first company to implement solar cell recycling, with its subsidiary, Deutsche Solar AG commissioning a pilot plant for the reprocessing of crystalline cells and modules. By the end of 2006, the production capacity of Solar World AG will be 220 MW, solar cells at 120 MW and solar modules at 80 MW. Solar World sells monocrystalline and polycrystalline silicon solar cells and modules.

References:

<http://www.solarworld.de/sw-eng/>

Solar World, Press Release, 3 June 2005

<http://www.solarworld.de/pressecorporatenews/index.php?seite=corporatenews-2005-06-003>

Photowatt

Photowatt International is a subsidiary of ATS Automation Tooling Systems Inc. Set up in 1979, Photowatt is involved also with the complete process of solar cell manufacturing, from the raw silicon ingot to the assembly of completed modules. Photowatt is located on the Bourgoin-Jallieu site near Lyon, France, and has a production capacity of 25 MW. By 2006, Photowatt will be increasing its production capacity to 60 MW. The company manufactures polycrystalline silicon solar cells using its proprietary POLIX® process. These solar cells have an efficiency range from 11.6% to 16.1% and sizes from four to six inches.

References:

<http://www.photowatt.com/>

Institut National de l'Énergie Solaire, Bulletin no 12, Juin 2005

ErSol Solar Energy AG

The ErSol group is an integrated supplier of silicon ingots to solar cells. Following the acquisition of ASi GmbH, ErSol produces ingots and wafers (ASi GmbH) and the fabrication of solar cells (ErSol AG) and distributes them through its subsidiary, Aimex-Solar GmbH.

The ErSol group began as ErSol Solarstrom GmbH & Co. KG in March 1997. A year later in July 1998, the production of polycrystalline silicon solar cells began. In August 2000, the E5 Blue Power solar cell with an efficiency of 14% was launched, with the manufacturing capacity increased to 5.5 MW a year later in June 2001. Since then, the production capacity as well as solar cell efficiency has steadily increased over the years to 17% for the monocrystalline E6M+ Black Power solar cell and 25 MW production in 2004. A year later, a joint venture was established with the Shanghai Electric Solar Energy Co. Ltd, and the production capacity was increased to 60 MW. In 2006, ErSol prepares to enter into the thin film module production, and acquires silicon recycler SRS (Silicon Recycling Services Inc.)

ASi Industries GmbH is a specialist manufacturer of monocrystalline silicon ingots and wafers. At its Erfurt production plant, ErSol Solar Energy currently manufactures monocrystalline and polycrystalline silicon solar cells with maximum efficiencies of 17% and 16% respectively.

Reference: <http://www.ersol.de/en/index.php>

Sunways AG

Sunways was incorporated in December 1993 and was transformed into a stock corporation or “Aktiengesellschaft” in German, in the year 1999. Sunways then acquired MHH Solartechnik GmbH, Tübingen in the year 2000. Since then, Sunways has set up several research projects such as the RGSells and PROKON research projects with the EU and the Federal Ministry for Economy and Labour respectively. Also Sunways has won numerous awards for its Transparent Sunways Solar Cells, such as the Top 3 iF Ecology Design Award (1999), the Red Dot Award for high quality design (2000), the iF Design Award 2004 and the International Design Award Baden-Württemberg (2004). Beginning 2006, Sunways has also begun producing its own complete modules.

Since September 2005, Sunways Production, a subsidiary of Sunways, has been producing monocrystalline and polycrystalline solar cells with an efficiency of up to 17%. Sunways also produces 10% transparent solar cells with an efficiency of up to 13.8%.

Reference: <http://www.sunways.de/en/>

Würth Solar GmbH & Co. KG

Würth Solar was founded in 1999 with the aim of building up Europe’s first commercial production of CIS solar modules. The initial research on CIS technology was carried out by the Institute of Physical Electronics / University of Stuttgart, as well as development of production technology at the Centre for Sun Energy and Hydrogen Research Baden-Württemberg – ZSW. Production began in the second half of the year 2000 in Marbach on the Neckar and a second factory was opened in 2003. In 2002, the production volume was 120 kW, increasing to 450 kW in 2003. Upon the completion of the second plant in the same year, the production volume was increased to 1.2 MW. A new CISfab was dedicated in October 2005, and when completed in 2007 will boast of a production capacity of 14.8 MW corresponding to 200,000 CIS modules per year.

Reference: http://www.wuerth-solar.de/we_web/frames,LA,DE,KA,226.php?parLANG=EN

Photovoltech

Photovoltech (Tienen, Belgium) was set up in December 2001 with the backing of three shareholders: Total and Electrabel (47.8%), Suez-Electrabel-Soltech (47.8%) and IMEC (4.4%).

From November 2003, the company has been producing polycrystalline silicon solar cells. These solar cells produced have maximum efficiencies of 16.3%, and a unique innovation is the MAXIS BC+ cell which has the contact metallization on the back of the cell. Current production capacity is at 13 MW per year, and is targeted to increase to 80~85 MW by the end of 2008.

Reference: http://www.photovoltech.be/html/UK/set_main.asp

PV Crystalox Solar AG

PV Crystalox Solar arose from the merger of two companies, Crystalox Ltd. in Wantage near Oxford, UK and PV Silicon AG in Erfurt, Germany. The company is one of the world's leading suppliers of monocrystalline and polycrystalline silicon ingots and wafers for use in solar cells. Silicon ingot production is carried out in its facility at Wantage whilst wafers are produced in the Erfurt facility. The annual revenue was reported to be 98.5 million Euros in 2004.

Reference: <http://www.pvsilicon.com/>

Renewable Energy Corporation AS

The Renewable Energy Corporation (REC) group comprises of three main divisions, REC Silicon which produces solar grade silicon and electronics grade polysilicon. REC Silicon is the world's largest dedicated producer of solar grade silicon and is based in the United States. REC Wafer produces polycrystalline wafers for the solar cell industry at two production facilities in Norway, as well as monocrystalline ingots for wafer production at a separate plant in Norway. REC Wafer is the world's largest producer of polycrystalline wafers. REC Solar produces solar cells at its plant in Norway and solar cell modules at its facilities in Sweden.

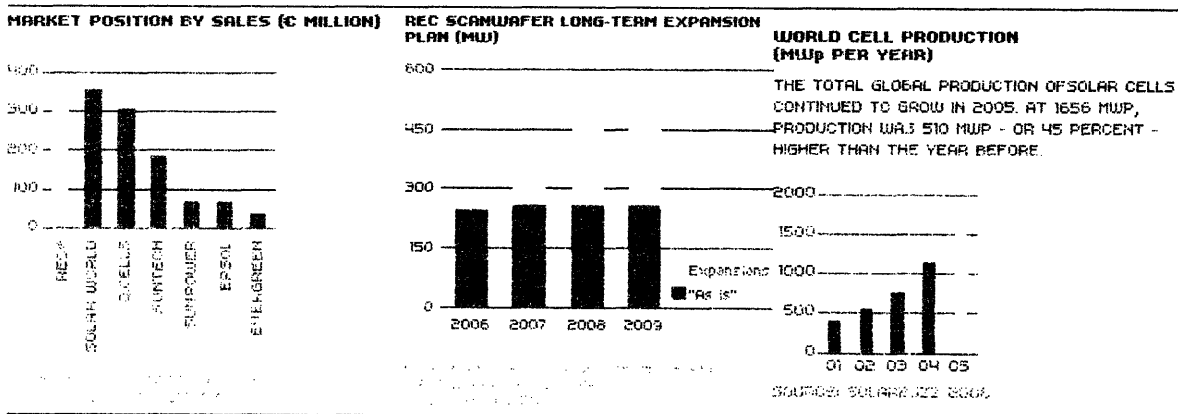

The REC group boasted a profit of 30 million Euros before tax in 2005, and aims to become the most cost-efficient solar energy company in the world, with a presence throughout the value chain.

The REC group was first established in 1994 under the name ScanWafer. Subsequently in 1997, a production facility of 2 MW was started. It was only in the year 2000 that Renewable Energy

Corporation was established and in 2004 where ScanWafer became a 100% subsidiary of REC. In 2005, SiTech AS and Advanced Silicon Materials LLC were acquired, and a year later in 2006, REC was listed on the Oslo Stock Exchange.

REC Silicon produces its polysilicon ingots using silane gas deposition and has invested in fluidized bed reactors (FBR) rather than the traditional thermal deposition furnaces. Production volume in 2005 was 20 MW in solar cells and 14 MW in solar modules. The current production capacity is 45 MW in 2006.

Reference: <http://195.26.0.70/>

Siltronic AG

Siltronic is a division of Wacker Polysilicon and is involved in the production of hyperpure silicon wafers for the electronics industry. Siltronics produces 300 mm wafers at its new plant in Freiberg using either the Czochralski crystal pulling furnace or using float zone technology and also provides Silicon-on-Insulator wafers.

Reference: http://www.siltronic.com/int/noc/?locale=en_US

UNAXIS Solar

UNAXIS Solar is a new name in the photovoltaic industry, but is a recognized world leader in thin film technology. Its equipment, Solar 1200, is capable of mass producing amorphous silicon complete with device processing and module assembly. Thin amorphous silicon films can be deposited on large glass substrates that offer large economies of scale. Other advantages cited are less material and energy required for production. Uniaxis Solar cells combine an amorphous silicon subcell with a microcrystalline subcell for higher conversion efficiency.

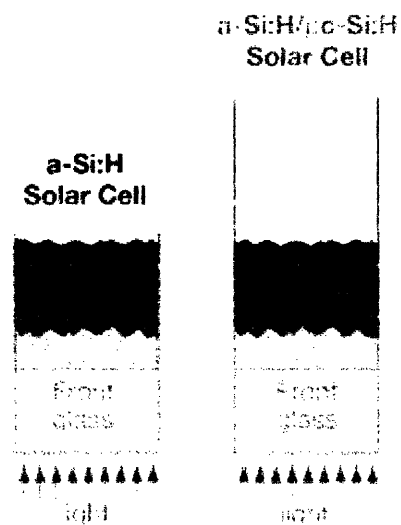

In 2004, Unaxis opened a solar R&D line in Trübbach, Switzerland for the development of advanced thin film silicon solar cell production technology.

Reference: <http://www.unaxis.com/solar/index.htm>

Note: Gesellschaft mit beschränkter Haftung (GmbH) is a type of business structure in Germany, Austria and Switzerland similar to a limited liability company (LLC) in the United States. Other abbreviations with the same meaning include GesmbH (more common in Austria), mbH when the term Gesellschaft is part of the company name and also gGmbH (gemeinnützige GmbH) for nonprofit companies e.g. hospitals or nursing homes. ([cn.wikipedia.org/wiki/GmbH](http://en.wikipedia.org/wiki/GmbH))

Appendix 13

Emcore

<http://www.emcore.com/>

Product Specifications:

- 1) InGaP/GaAs/Ge Triple junction solar cell:¹ (area of 27.5 cm²)
 - a. Triple junction BOL (beginning-of-life) efficiency 26.0%
 - b. Radiation resistance $P/P_0 = 0.91$ @ 1MeV, 5E14 e/cm²
 - c. Remaining power after 1E15 e/cm²: 0.87
 - d. Remaining power after 5E14 e/cm²: 0.91
 - e. Temperature coefficient: 0.06 absolute %/°C
 - f. EOL (end-of-life) efficiency at 5E14 e/cm²: 23.7%

InGaP/GaAs/Ge Triple junction solar cell performance:

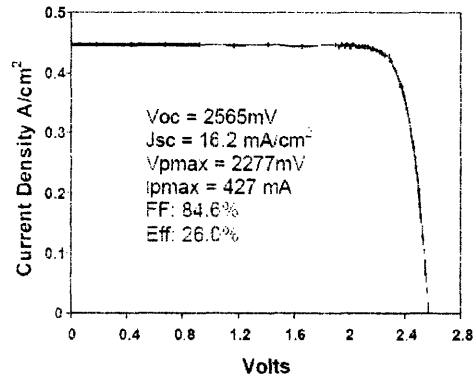

**Flight cell Beginning-of-Life efficiency
for any shipment to range from 24.5%
to 28%**

- 2) InGaP/InGaAs/Ge Triple junction solar cells for space application:²
 - a. Solar cell mass 84mg/cm², area of 26.6 cm²
 - b. Space-qualified for LEO and GEO environments
 - c. Radiation resistance $P/P_0 = 0.89$ @ 1MeV, 5E14 e/cm²
 - d. BOL efficiency 27.5%

InGaP/InGaAs/Ge Triple junction solar cells performance:

¹ <http://www.emcore.com/assets/photovoltaics/Triple.pdf>

² http://www.emcore.com/assets/photovoltaics/PhotoV_ATJ_Prod_Sheet.pdf

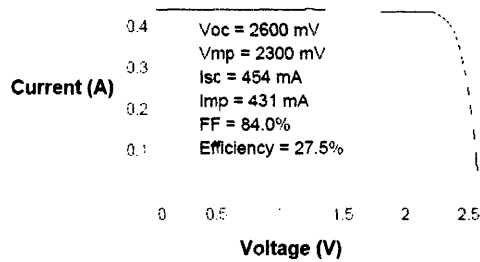

**Radiation Performance at 1MeV electron irradiation EOL/BOL ratios:
Temperature coefficients:**

Fluence (e/cm ²)	Voc	Isc	Vmp	Imp	Pmp	Efficiency	Fluence (e/cm ²)	$\Delta Voc/\Delta T$ (mV/°C)	$Jsc/\Delta T^{(1)}$ $\mu A/°C cm^2$	$Vm/\Delta T$ mV/°C	$Jmp/\Delta T^{(2)}$ $\mu A/°C cm^2$
5E13	0.97	1.00	0.97	1.00	0.97	0.97	BOL	-5.48	-12	-5.66	-11
1E14	0.96	1.00	0.96	1.00	0.96	0.96	5E13	-5.49	-10	-5.68	-7
5E14	0.92	0.98	0.92	0.98	0.89	0.89	1E14	-5.46	-11	-5.69	-7
1E15	0.90	0.96	0.90	0.94	0.85	0.85	5E14	-5.61	-12	-5.90	-10
5E15	0.86	0.90	0.85	0.87	0.74	0.74	1E15	-5.77	-12	-6.14	-13

Space qualification results:

Test	Industry Quality Standard	Typical Test Results
Metal Contact Thickness	4-10 μm	6 μm
Dark Current degradation after reverse bias	$\Delta Ispec < 2\%$	<0.4%
Electrical performance after 2,000 thermal cycles -180°C to +95°C	<2%	<0.7%
High-Temperature Anneal at 200°C for >5,000 hrs.	<2%	No measurable difference
Contact pull strength	>300 grams	>600 grams
Electrical performance degradation after 40 day humidity exposure at 60°C and 95% RH	<1.5%	No measurable difference

Multijunction solar cells with monolithic bypass diodes:³

- 1) Bypass diode present to prevent reverse bias breakdown of solar cell
- 2) Requirements for diode: must be able to protect cell, has to be reliable and process must be simple.

Space qualifications tests for monolithic bypass diode: (area = 7mm²)

3

http://www.emcore.com/assets/photovoltaics/3O_D9_03%20MJ%20Cells%20with%20Monolithic%20Bypass%20Diodes.pdf

Test Item	Requirement
Reverse Bias	$I_{RB} < 30 \mu A$ $\Delta V_{FB} < 10\%$
Forward Bias	$I_{RB} < 30 \mu A$ $\Delta V_{FB} < 10\%$
Diode Cycling	$I_{RB} < 30 \mu A$ $\Delta V_{FB} < 10\%$
Irradiation: Electrons	$I_{RB} < 30 \mu A$ $\Delta V_{FB} < 10\%$
Protons	

I_{RB} was measured at 2.5 volts reverse bias, and ΔV_{FB} refers to the change in the forward bias voltage needed to pass 500 mA through the diode before and after the particular test.

The Development of >28% efficient triple-junction space solar cells at Emcore Photovoltaics:⁴

- 1) III-V multijunction solar cells preferred for satellites because of higher radiation hardness and higher conversion efficiency
- 2) Triple junction (TJ), advanced triple junction (ATJ) and ATJ with monolithic bypass have average efficiency of 26.0%, 27.5%, and 27.5% respectively
- 3) Average mass density of 86 mg/cm²
- 4) AR coating of TiO_x/Al₂O₃ dielectric stack
- 5) For GEO mission of 15-20 years, power degradation is 11~15%

Solar Array Trades between very high efficiency multijunction and Si space solar cells:⁵

- 1) Assumption that the end-of-life (EOL) conditions for GEO and LEO will be equivalent to degradation due to 1 MeV electrons at 5E14 and 1E15 e/cm² respectively.
- 2) Parameters critical to conventional rigid solar arrays such as specific power/mass (W/Kg), specific mass/area (Kg/m²), specific power/area (W/m²), and normalized EOL \$/W
- 3) Compared to Si, multi-junction cells are more radiation resistant and have greater energy conversion efficiencies, but they are also heavier (higher density and thickness) and cost more.
- 4) The solar cell characteristics that primarily determine EOL power are particle irradiation and temperature coefficient degradation mechanisms. Other secondary effects such as ultra-violet (UV) and thermal cycling degradation mechanisms also affect EOL power in space.
- 5) The use of the Ge substrate has two advantages over III-V compound semiconductor substrates such as GaAs: lower cost and higher structural breakage strength. These advantages make the manufacturing of these solar cells cost effective.
- 6) GaAs and Ge substrates are denser than Si substrates. Si substrates are less brittle than Ge, and have the greater strength to be safely manufactured at low thickness values. The combination of lower density and higher material strength enables Si cells to have a low mass per unit area (Kg/m²) figure of merit.

⁴ http://www.emcore.com/assets/photovoltaics/Emcore_Manuscript_Fatemi_3P-B5-03_WCPEC-3.pdf

⁵ http://www.emcore.com/assets/photovoltaics/Paper_Navid_9-22-00.pdf

Solar Cell Technology	BOL Min. Ave. η (%)	EOL Temp. Coefficient (abs. %/°C)	P/Po (5E14 e/cm ²)	P/Po (1E15 e/cm ²)
3-mil High-Efficiency Si	17.0	-0.053	0.83	0.79
2J	23.5	-0.030	0.89	0.84
3J	26.0	-0.045	0.92	0.87

Solar Cell Technology	Thickness (μm)	Kg/m ²
High-Efficiency Si	75	0.23
2J	140	0.85
3J	140	0.85

Solar Cell Technology	EOL Efficiency @ 28°C (%)	EOL Efficiency on Orbit (%)
GEO Conditions (60°C) – 1-MeV, 5E14 e/cm ²		
High-Efficiency Si	14.1	12.5
2J	20.9	20.0
3J	23.9	22.6
LEO Conditions (80°C) – 1-MeV, 1E15 e/cm ²		
High-Efficiency Si	13.4	10.6
2J	19.7	18.1
3J	22.6	20.3

Solar Cell Technology	W/m ²	W/Kg	Normalized Cost (\$/W)
GEO Conditions (60°C) – 1-MeV, 5E14 e/cm ²			
3-mil High-Efficiency Si	169	676	1.00
2J	271	319	1.38
3J	306	360	1.22
LEO Conditions (80°C) – 1-MeV, 1E15 e/cm ²			
3-mil High-Efficiency Si	143	574	1.00
2J	245	288	1.29
3J	275	323	1.15

- 7) In general, smaller arrays desirably reduce the satellite weight, array stowage volume, and system requirements on spacecraft attitude control systems including the rate of chemical fuel usage. Three other important figures of merit for a solar cell are EOL area power density (W/m²), specific weight (W/Kg), and cost (\$/W).

27.5% Efficiency InGaP/InGaAs/Ge advanced triple junction (ATJ) space solar cells for high volume manufacturing:

http://www.emcore.com/assets/photovoltaics/29th_PVSC%20Stan.pdf

- 1) Inclusion of Indium into the second cell of the InGaP/GaAs/Ge triple junction cell improves performance.
- 2) To move towards the optimum conversion efficiency, one must increase the top cell bandgap and lower the middle cell bandgap. In addition there is the added constraint that the epi-materials remain lattice-matched to the underlying substrate in order to avoid dislocation formation.
- 3) The highest measured efficiency for a large-area (26.6 cm²) production solar cell was 29.2% (AM0, 135.3 mW/cm², 28°C). To the best of our knowledge, this is the highest measured efficiency for a large-area flight InGaP/InGaAs/Ge triple-junction solar cell grown on a Ge substrate.
- 4) Degradation of the advanced triple junction cell with high energy ionizing radiation is comparable to that of the first generation triple-junction. This result suggests that the addition of a small indium mole fraction to the GaAs middle cell results in no deleterious effects in the radiation hardness.

- 5) The advanced triple-junction has benefited from an improved “blue” response in the Ge subcell, the addition of indium to the middle cell, and better bulk InGaP quality in the top subcell.

Temperature dependent spectral response measurements for III-V multi-junction solar cells:

http://www.emcore.com/assets/photovoltaics/29th_PVSC%20Aiken.pdf

- 1) The InGaP, InGaAs, and germanium temperature coefficients are 0.011, 0.009, and 0.044 mA/cm²/°C, respectively.
- 2) For space to near sun missions, This wide range of environments results in operating temperatures from sub-zero to over 100°C.
- 3) The series interconnected design of these solar cells implies that subcell current matching is imperative for achieving the highest possible performance.
- 4) Because individual subcells convert only a narrow range of spectral wavelengths into photocurrent, their spectral response characteristics are therefore very sensitive to changes in temperature

Appendix 14

Spectrolab

<http://www.spectrolab.com/>

Space solar cells performance table:⁶

	Si K6700B wrapthru	Si K6700B	Si K4710	Si K4702	Single junction	Dual junction	25.1% triple junction	26.8% ITJ	28.3% UTJ
Typical Electrical Parameters (AM0 135.3mW/cm², 28°C, bare cell)									
J _{sc} mAcm ⁻²	41.9	39.0	39.3	39.2	30.5	15.05	15.6	16.9	17.05
J _{mp} mAcm ⁻²	38.4	37.0	36.6	36.8	28.6	14.15	14.9	16.0	16.3
V _{mp} V	0.5	0.5	0.454	0.490	25.7	2.085	2.275	2.27	2.35
P _{mp} mWcm ⁻²	19.2	18.5	16.6	18	1.025				
V _{oc} V	0.618	0.605	0.545	0.585	0.900	2.360	2.545	2.565	2.665
Cff	0.74	0.78	0.78	0.79	0.82	0.83	0.85	0.84	0.84
Efficiency	14.2	13.7	12.3	13.3	19.0	21.5~8	24.5~25.1	26.5~8	28.0~3
Radiation Degradation (1E15 e/cm² 1 MeV e⁻ except wrapthru 5E14)									
I _{sc} /I _{sc0}	0.85	0.91	0.91	0.81					
I _{mp} /I _{mp0}	0.85	0.90	0.91	0.81	0.83	0.92	0.90	0.96	0.96
V _{mp} /V _{mp0}	0.82	0.85	0.92	0.91	0.90	0.91	0.92	0.88	0.89
V _{oc} /V _{oc0}	0.84	0.87	0.94	0.91					
P _{mp} /P _{mp0}	0.70	0.77	0.83	0.74	0.75	0.83	0.83	0.84	0.86
Thermal Properties (ceria doped microsheet for non-Si)									
CMX solar Absorbance	0.65	0.75	0.74	0.74	0.89	0.92	0.92	0.92	0.92
Silica solar Absorbance	0.63	0.73	0.69	0.69	0.88				
CMX emittance	0.85	0.85	0.85	0.85	0.85	0.85	0.85	0.85	0.85
Silica emittance	0.81	0.81	0.81	0.81	0.81				
Temperature coefficients (1E15 e/cm² 1 MeV e⁻ for non-Si, weight: 175µm and 140µm)									
I _{sc} µA/cm ²	+20	+22	+20	+20	+20	12	11	12.4	6
V _{mp} mV/°C	-2.15	-2.15	-2.33	-2.20	-1.90	-5.0	-7.2	-6.6	-6.7
V _{oc} mV/°C	-1.96	-1.96	-2.20	-2.08	-1.80	-4.8	-6.8	-6.5	-6.3
Weight mg/cm ²	55	24	55	55	100 80	84 84	84 84	84 84	84 84

Solar Panel performance table:⁷

⁶ <http://www.spectrolab.com/prd/space/cell-main.asp>

⁷ <http://www.spectrolab.com/DataSheets/Panel/panels.pdf>

	Single Junction: GaAs/Ge	Dual Junction: GaInP ₂ /GaAs/Ge	Triple Junction (TJ): GaInP ₂ /GaAs/Ge	Improved Triple Junction (ITJ): GaInP ₂ /GaAs/Ge	Ultra Triple Junction (UTJ): GaInP ₂ /GaAs/Ge
Power (28°C, Beginning Of Life) • Panel Area > 2.5 m ² • Panel Area < 2.5 m ²	241 W/m ² 228 W/m ²	266 W/m ² 252 W/m ²	302 W/m ² 289 W/m ²	330 W/m ² 316 W/m ²	350 W/m ² 330 W/m ²
Mass (add-on to substrate) • 3 mil Ceria Doped Coverslide • 6 mil Ceria Doped Coverslide	1.61 kg/m ² 1.89 kg/m ² (5.5 mil thick equivalent solar cell for both cases above)	1.61 kg/m ² 1.89 kg/m ² (5.5 mil thick equivalent solar cell for both cases above)	1.76 kg/m ² (5.5 mil thick cell) 2.06 kg/m ² (5.5 mil thick cell) 2.36 kg/m ² (7.5 mil thick cell)	1.76 kg/m ² (5.5 mil thick cell) 2.06 kg/m ² (5.5 mil thick cell) 2.36 kg/m ² (7.5 mil thick cell)	1.76 kg/m ² (5.5 mil thick cell) 2.06 kg/m ² (5.5 mil thick cell)
Thermal Control • Front: Ceria Doped Coverslide* • Rear	$\alpha=0.89$ $\epsilon=0.86$ $\alpha=0.1-0.9$ $\epsilon=0.9$	$\alpha=0.92$ $\epsilon=0.86$ $\alpha=0.1-0.9$ $\epsilon=0.9$	$\alpha=0.92$ $\epsilon=0.86$ $\alpha=0.1-0.9$ $\epsilon=0.9$	$\alpha=0.92$ $\epsilon=0.86$ $\alpha=0.1-0.9$ $\epsilon=0.9$	$\alpha=0.92$ $\epsilon=0.86$ $\alpha=0.1-0.9$ $\epsilon=0.9$
Magnetic Dipole Moment	Standard: < 0.5 Am ² . Special: 0.0 Am ² (Magnetic Field < 3 nT Measured At End Of Array Wing)				
Reliability	Demonstrated 0.999 for 5kW Array				

Spectrolab Terrestrial Concentrator Solar Cell Technology Roadmap⁸

World-record of 34.2% Achieved in 2001, Recognized As One of the Top 100 Achievements by R&D Magazine and One of the Top 50 Achievements by Scientific American Magazine

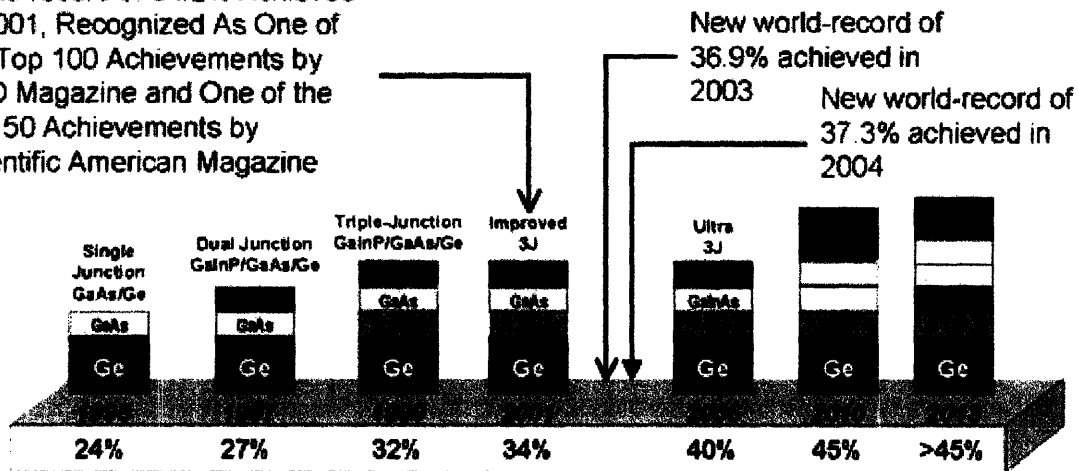

Products from Spectrolab:⁹

- 1) Solar cells, panels and arrays for space
- 2) Photodetectors
- 3) Concentrator cells and receivers, single cells for simple applications
- 4) Solar simulator, solar test kit

⁸ <http://www.spectrolab.com/prd/terres/cell-main.htm>

⁹ <http://www.spectrolab.com/prd/prd.asp>

Appendix 15

Japanese renewable energy policy

Principle of Japan energy policy – 3Es

- 1) Security of Japanese Energy Supply (Alternatives to oil)
- 2) Economic efficiency (Market mechanisms)
- 3) Harmony with Environment (Cutting CO₂ emissions on line with Kyoto targets)

The current basic energy policy is based on market principles, but seeks to ensure a stable supply and environmental friendly production and consumption of energy at the same time.¹

The scarcity of natural conventional energy resources in Japan, the current status of mid/long term supply of oil and the risks for a stable energy supply for Japan, as well as the need to address global environmental problems such as reducing emissions of greenhouse gases like CO₂, increase the need to accelerate the advancement of implementation of new energy.

The ‘Basic Guidelines’ were set by the ‘Council of Ministers for the Promotion of Comprehensive Energy Measures’ in December 1994 and were based on a Cabinet Decision in September 1994.

Basic guidelines for New Energy Introduction

The Japanese policy not only has the advantage of being much more market-oriented, but also has a major aim in the policy guidelines: “The establishment of a prospering market”. These expectations are also expressed by the long-term goals, which already in 1994 made a commitment for the next fifteen years until the year 2010. This long-term policy and commitment constitute an enormous advantage as industry can rely on such a long-term programme and plan their individual industry policy as well.

Law concerning the promotion of development and the introduction of oil alternative energy (Alternative Energy Law)

Enacted in 1980 and amended in 1992 to provide a legal framework for the development and implementation of oil alternative energies in order to secure a stable and appropriate supply of energy. In addition to the determination and public announcements of oil alternative energy targets, it employs various measures through New Energy and Industrial Technology Development Organisations.

Long-term Energy supply/demand outlook

The "Long-term Energy Supply/Demand Outlook" was determined from the viewpoint of advancing the promotion of implementation of non-fossil energy such as New Energy and nuclear power, etc. It represent efforts aimed at stabilising the supply of energy and further improving energy consumption efficiency. This forecast was revised in June 1998 based on the targeted reduction of carbon-dioxide emissions of Japan for 2010, decided at the COP3 in December 1997. Additionally, the “Long-term Energy Supply/Demand Outlook” was revised in July 2001 to represent the desired energy supply and demand figures in the future.

Law concerning special measures for promotion of New Energy Use etc. (New Energy Law)
Enacted in April 1997 to accelerate the advancement of the introduction of New Energy, the law aims to achieve its targets by 2010. This law, while clarifying the role of each area for the overall advancement of New Energy usage, provides the financial support measures for utilities that use New Energy.

The Japanese RPS market went into effect on 1 April 2003 based, on the "Special Measures Law Concerning the Use of New Energy by Electric Utilities". The goal is to increase the total usage of New Energy up to 12.2 TWh by 2010 or 1.35% of the electricity. Under this scheme the national government requires each electric power company to use a certain amount of electricity, depending on its electricity sales, generated from new energies. The power companies can select the most advantageous way for them from the following options:

- 1) self-generation of new energy
- 2) purchasing of new energy from others
- 3) subrogation of the obligation to another company

The legislation is aimed at tripling the FY 1999 ratio of new energy in the total power supply to 3.2% by FY 2010 (currently: 0.2% is RE excluding hydro and geothermal; target here 1.1%) as part of Japan's efforts to attain the greenhouse gas reduction target of the Kyoto Protocol.

METI summary of policy drivers in Japan:

- Contribution to securing a stable energy supply as an oil alternative energy.
- Clean energy with a small burden on the environment.
- Contribution to new industry and job creation.
- Advantage of creating a decentralized energy system.
- Contribution of load leveling for electric power (effect reducing energy peaks.)

Implementation of photovoltaics

The Japanese implementation programme for Photovoltaics is the longest running. It started with the "Monitoring Programme for Residential PV systems" from 94 to 96, followed by the "Programme for the Development of the Infrastructure for the Introduction of Residential PV Systems", which has been running since 1997 and will end at the end of FY2005. During this period, the average price for 1 kWp in the residential sector fell from 2 million ¥/kWp in 1994 to 670,000 ¥/kWp in 2004.

In the year 2005, the subsidy for PV roof top systems was reduced to 20,000 ¥ per kWp.

The remark of Ms. Yokiko Araki, Director of the New and Renewable Energy Division of the Agency for Natural Resources and Energy (ANRE) of the Ministry of Economy, Trade and Industry (METI) during the June 2005 Symposium on "Photovoltaic Generating Systems" that one of the mid- to long-term strategies to reduce the dependency from oil was to be the No. 1 PV power nation could be seen as an announcement for new measures to implement PV on an even larger scale than already today.

In addition to the national subsidy, handled by NEF, some local governments (more than 370 additional local subsidising bodies) add supplementary funds of a maximum of 40% of the total installation costs of the systems.

Although the amount of METI subsidy is decreasing, the number of residential PV systems in Japan is increasing every year. This can be attributed to the dissemination of PV systems.²

- 1) The number of municipalities which offer additional subsidies and soft loans for residential PV systems has increased substantially.
- 2) More and more municipalities adopt PV systems to public buildings.
- 3) PV companies developed and commercialized systems especially adopted for roofs with small areas and complicated shapes.
- 4) The market for houses which use electricity as only energy source is increasing and PV systems were adopted as a key item for these “all-electrification” houses.
- 5) Several housing manufacturers developed “zero-energy houses”. Such houses combine PV installation, energy efficient water supply and an airtight housing structure that maintains a constant temperature inside the home. In addition they trained their sales staff to understand the functionality of photovoltaic systems.
- 6) More and more solar cell and house manufacturers promote PV systems through TV commercials, thus increasing the consumers understanding for PV systems and their purchase intention.
- 7) An increasing number of customers focus their attention on economic efficiency as well as environmental impact.

Electricity production averages 950 kWh/kWp per year in Japan and even the snow-rich west coast along the Japanese Sea, the so-called Snow-Land, averages 850 kWh/kWp per year. This means that average annual electricity savings are approximately 23,400 ¥/kWp and 21,000 ¥/kWp respectively.

The METI “Vision for New Energy Business” announced in June 2004 confirms the support policy. This new strategy paper is aimed at developing an independent and sustainable new energy business and various support measures for PV are explicitly mentioned. The key elements are:

- 1) Strategic promotion of technological developments as a driving force for competitiveness.
 - Promotion of technological development to overcome high costs.
 - Development of PV systems to facilitate grid-connection and creation of the environment for its implementation.
- 2) Accelerated demand creation.
 - Develop a range of support measures besides subsidies.
 - Support to create new business models.
- 3) Enhancement of competitiveness to establish a sustainable PV industry.
 - Establishment of standards, codes and an accreditation system to contribute to the availability of human resources as well as securing performance, quality and safety.
 - Enhancement of the awareness for photovoltaic systems.
 - Promotion of international co-operation.

During the Programme evaluation in 2000, the following connections which are of strategic importance for the shaping of future research and development programmes were identified between R&D on the one side and market implementation of photovoltaics on the other.³

- To realize the scenario of mass production of solar cells and low costs for PV systems it is important to stimulate technical R&D and market implementation simultaneously.
- It is also essential to define price/cost targets for R&D processes. Such targets are always the best motivation for private companies to undertake their own R&D endeavors, as soon as markets emerge.
- Roof integrated PV systems have developed into a promising market and ensure penetration in large numbers in Japan. This trend might also be explained by the rather high electricity price in Japan of approx. 24 ¥/kWh for private customers.
- To realize the scenario of mass production and low costs for PV systems, it is even more important that big companies or consortia, which have the ability to place and receive large orders for PV systems in bulk with good sales logistics, e.g. trading companies, appear on the stage. In Japan, housing companies have played a significant role to increase orders for PV systems. Approximately 500 000 new houses are built in Japan every year and the activities of the housing companies in marketing PV systems have led to a significant increase of orders for PV manufacturers. Normally 50% of the PV systems sold in Japan each year are sold with a new house. The advantage for the customer is the lower price of the system, completely integrated into the new house and the low financing costs, as additional costs are included in the house loan.

References:

1. METI Brochure, Energy in Japan 2005 <http://www.enecho.meti.go.jp/energy2005E.pdf>
2. Osamu Ikki, PV Activities in Japan, Volume 10. No 5, May 2004
3. *The New Role of PVTEC for Developing PV Technology in Japan*, Nobuaki Mori, PVTEC Tokyo, 2001

Appendix 16

China renewable energy policy

The main thrust of China's strategy is to diversify its energy supply system and overcome the existing energy shortage.

The PRC's continental solar power potential is estimated at 1,680 billion toe (equivalent to 19,536,000TWh) per year. One percent of China's continental area, with 15% transformation efficiency, could supply 29,304 TWh of solar energy or 189% of the world wide electricity consumption in 2001.¹

During the International Conference for Renewable Energies, Bonn, in June 2004, the People's Republic of China (PRC) announced the plan that by 2010 installed capacity of renewable energies will total about 60 GW and account for about 10% of China's total installed power generation capacity.²

According to an earlier report of the China Sustainable Energy Programme, cumulative capacity of installed photovoltaic systems could be in the range of 4 to 8 GWp.³

The Standing Committee of the National People's Congress of China endorsed the Renewable Energy Law on 28 February 2005. The Renewable Energy Law will go into effect on 1 January 2006.

In June 2005 the World Bank's Board of Executive Directors approved a loan of US\$ 87 million to China to finance the Renewable Energy Scale-up Programme, supplemented by a grant of US\$ 40.22 million from the Global Environment Facility (GEF). The project's objective is to expand renewable electricity supply in China efficiently, cost effectively and on a large scale.⁴

Already in the spring of 2004, the World Bank approved a loan and Global Environment Facility (GEF) grant to China for the Renewable Energy Development Project (REDP), which includes a large photovoltaic market development component and a photovoltaic technology improvement component.

The PV Market Development (PV) Component will provide assistance to photovoltaic system companies to market, sell, and maintain an estimated 300,000 – 400,000 systems in remote rural areas of China's north western provinces. This part of the programme supports participating PV system companies in the provision of electricity services using PV or PV/wind hybrid systems in household or community facilities in Qinghai, Gansu, Inner Mongolia, Xinjiang, Sichuan and Xizang and adjacent counties (in total about 10 MWp of PV). However, to date there is no test facility in China yet that has the capacity to carry out certified tests on PV modules according to IEC61215-1993/GB9535-1998.

The latest and largest solar initiative was launched in Shanghai, were according to the China Internet Information Centre a government-funded project, to turn the city's roofs into sites for

solar-energy production, will soon be submitted for final approval. The project calls for a 100,000 solar roof programme for Shanghai, which would correspond to approx. 360 MWp and an annual production of 432 GWh.⁵

References:

1. China Development Forum 2003, 15 to 17 November 2003 Background Reports for China's National Energy Strategy 2000 to 2020
http://www.efchina.org/documents/Draft_Natl_E_Plan0311.pdf
2. International Conference for Renewable Energies, Bonn, 1 -4 June 2004, International Action Plan and List of Actions and Commitments
http://www.renewables2004.de/en/2004/outcome_actionprogramme.asp
3. Z. Zhengming, W. Qingyi, Z. Xing, J. Hamrin and S. Baruch, *Renewable Energy Development in China: The Potential and the Challenges*; Edited and produced by the Centre for Resource Solutions http://www.efchina.org/documents/China_RE_Report_EN.pdf
4. China Internet Information Centre, 17 June 2005
http://service.china.org.cn/link/wcm/Show_Text?info_id=132365&p_qry=solar
5. Ibid.,

Appendix 17

The California Assembly has passed SB 1, authorizing over \$3.35 billion in funding to deploy 3,000 MW of solar power in the state within 10 years.

California Assembly Moves Ahead on 3,000 MW Solar Initiative, June 30, 2006
<http://www.seia.org/solarnews.php?id=117>

California Gov. Arnold Schwarzenegger (R) and California Public Utilities Commissioner Michael Peevey both urged the California congressional delegation to enact H.R. 5206 and S. 2677, companion bills aimed at extending the solar tax credit for eight years. The "Securing America's Energy Independence Act" would extend solar energy and fuel cell investment tax credits for homeowners and businesses through 2015. The credits are currently set to expire next year.

SEIA estimates that a long-term credit extension would create approximately 55,000 solar industry jobs by 2015 and encourage states to invest billions of dollars in renewable energy infrastructure. Solar energy would displace 4 trillion cubic feet of natural gas under the bill, saving U.S. consumers \$32 billion over equipment lifetimes.

Early this year, the California Public Utilities Commission approved a \$3.2 billion program that would provide incentives for solar panel installation to residents and businesses. Over the next 11 years, the program aims to add 3,000 megawatts to the state's grid. It represents a victory for the governor, who had proposed the program as the Million Solar Roofs Bill a year earlier.

Gov. Schwarzenegger, CPUC President Peevey Urge Congress to Support "Securing America's Energy Independence Act", May 25, 2006
<http://www.seia.org/solarnews.php?id=111>

The New Jersey Board of Public Utilities (BPU) approved new regulations last week that will require the state's electric utilities to draw on wind power, solar power, and sustainable biomass power for 20 percent of their electricity by 2020.

The new regulations require solar photovoltaic power to provide 2 percent of the state's electricity needs by 2020, requiring the installation of 1,500 megawatts of solar electric power. New Jersey is already one of the fastest growing solar markets in the country, having grown from six solar power installations in 2001 to more than 1,200 installations today. The new goal will continue to spur market development and is considered the largest solar goal in the country on a per capita basis (exceeded only by California, which is four times the size of New Jersey in population and electricity consumption).

New Jersey Approves Regulations to Achieve 1,500 MW of Solar by 2020, April 19, 2006

<http://www.seia.org/solarnews.php?id=109>

The Department of Energy has released details of the "President's Solar America Initiative," proposing the largest funding increase for solar energy research in US budget history. First announced during President Bush's State of the Union address, the initiative aims to decrease the cost of solar to be competitive with existing sources of electricity in 10 years. The program also aims to deploy 5-10 GW of photovoltaics (PV) capacity by 2015 - enough solar electricity to power roughly 2 million homes.

The proposed FY 2007 budget for the SAI is \$148 million, a 78% budget increase, which includes \$139 million for PV and \$9 million for concentrating solar power. The Solar Energy Industries Association hailed this initiative as a key victory for the next great high-tech growth industry in the US: solar energy.

"Within 10 years, we estimate that this program will result in 10 GW of grid-connected solar electric capacity," said Mr. Rhone Resch, president of SEIA. "That would be 20 times today's levels, enough to reduce 10 million metric tons of CO₂ emissions annually. Moreover, the program will also help grow the industry with 30,000 new jobs in the US solar industry, and make solar electricity cost-competitive with conventionally generated electricity."

Department of Energy Unveils "President's Solar America Initiative" to Achieve Breakthroughs in Solar Power Technology, February 9, 2006
<http://www.seia.org/solarnews.php?id=101>

Federal solar tax incentives enacted in the Energy Policy Act of 2005 allow homeowners a tax credit of 30% for qualifying solar electric (PV) or solar water heating expenditures, up to a maximum of \$2,000 per technology. For businesses, the investment tax credit is increased from 10% to 30% of qualified solar property expenditures, with no cap on the credit amount. These incentives apply to equipment placed in service during 2006-2007.

SEIA Releases Guide to New Federal Tax Credits for Solar Energy, January 30, 2006
<http://www.seia.org/solarnews.php?id=96>

The California Public Utilities Commission (CPUC) today approved the California Solar Initiative, a program to install 3,000 megawatts of solar on California homes, businesses, farms, schools and public facilities over 11 years.

The California Solar Initiative creates 11 years of funding for consumer rebates. The CPUC will provide \$2.8 billion in customer incentives for solar projects on existing residential buildings, as well as all public buildings, industrial facilities, businesses, and agricultural facilities. The California Energy Commission, meanwhile, will provide \$400 million in incentives for new homes, specifically targeting collaborations with the builder / developer community. Incentives are to be gradually reduced over time and phased out by 2016 under the CPUC proposal.

California PUC Approves Nation's Biggest Solar Program, January 12, 2006
<http://www.seia.org/solarnews.php?id=93>

Deploying 10,000 megawatts of solar power by 2015 - enough to power five million homes across the country - would generate tens of thousands of jobs and add valuable peak power capacity to the electric grid. Establishing this kind of visionary national goal is critical because we face a national energy crisis. We must diversify our energy portfolio and develop more American energy resources - we cannot drill our way out of the energy crisis, but we can manufacture our way out, using clean technologies developed in this country. Commercial solar power can contribute immediately to the nation's peak power needs, and many states are already moving ahead to develop their solar power resources.

Pennsylvania is emerging as a premier market for solar power development and jobs. Under Governor Rendell, Pennsylvania passed a law to require 860 MW of solar power in the state by 2020. The state is now implementing that law and developing streamlined regulations for solar electric system interconnection and net metering - making it easy for consumers to connect their system to the grid and sell back power to utilities.

Speech delivered by Rhone Resch, SEIA president

Pennsylvania Governor Rendell Outlines National Target of 10,000 Megawatts of Solar Power by 2015, December 1, 2005
<http://www.seia.org/solarnews.php?id=79>

Appendix 18

The European Photovoltaic Industry Association (EPIA) and the European Union Solar policy

Objectives of EPIA:

- 1) To become the most credible reference point for the European PV Industry stakeholders. EPIA will provide accurate information, statistics and feedback to both its members and the wider audience.
- 2) To help shape the development of new PV markets both in Europe and export community.
- 3) To take the lead in positioning the photovoltaic industry within the European political environment and supporting the member state association in their local objectives.

Reference:

http://www.epia.org/03DataFigures/Presentations/Development_PV_Europe_BCSE_R.ppt

Three Action fields to achieve objectives:

- 1) Market growth strategy
 - a. Opportunities, perspectives, potentials and hurdles in the enlarged EU market
 - b. Export in non-EU countries
 - c. Socio-economic and financial issues
 - d. State-of-the-art and SWOT (strengths, weaknesses, opportunities and threats) Analysis
- 2) Products and services
 - a. Crystallizing the fruits of the European RTD (Research and Technology Development)
 - b. Engaging the construction industry in PV
 - c. Communication tools
 - d. Costs and prices trends
 - e. Certification and standards
 - i. IEC – International Electrotechnical Commission
 - ii. PV GAP – Global Approval Program for Photovoltaics
- 3) Lobbying
 - a. **European Institutions lobbying**
 - i. RES e-directive: In 2001 the European Union issued after long discussions between the different institutions the Directive on the promotion of electricity produced from renewable sources (RES-E directive). This Directive sets out to create a framework that will facilitate, on the medium term, a significant increase in renewable generated electricity within the EU. It constitutes an important milestone in shaping the regulatory framework for RES-E generation in the EU. The RES-E Directive might

even be a prelude to a possible future EU-wide harmonisation of regulatory frameworks at Member State level.

Reference: http://www.eufores.org/index.php?id=30#_Toc106430660

- ii. EU – PV technology platform: The Vision report , entitled "A Vision for PV Technology for 2030 and Beyond", identifies the major technical and non-technical barriers to the technology's uptake. The Council has also considered the merits of using a European Technology Platform as a mechanism to implement the strategy and achieve the goals defined in the vision.

Reference:

http://ec.europa.eu/research/energy/photovoltaics/introduction_en.html

- iii. European PV Industry policy and Competitiveness for the PV industry
- iv. DG-R&D (Directorate General for research and development) and DG-TREN (Directorate General for energy and transport) Programmes

b. National lobby in the EU countries

- i. Supports National associations and coordinates their political lobby
- ii. Acts with Policy institutions (network of National Energy Agencies)

c. International lobby

- i. Global Photovoltaic Solar Electricity Council (GPSC)
 - 1. CanSIA – Canadian Solar Industries Association
 - 2. SEIA – The Solar Energy Industries Association
 - 3. EPIA – European Photovoltaic Industry Association
 - 4. CREIA – China Renewable Energy Industries Association
 - 5. JPEA – The Japan Photovoltaic Energy Association
 - 6. TPIA – Taiwan PV Industry Association
 - 7. KPDO – Korean Photovoltaics Development Organization
 - 8. BCSE – Australian Business Council for Sustainable Energy
 - 9. NZPVA – New Zealand Photovoltaic Association

Reference:

http://www.epia.org/03DataFigures/Presentations/Development_PV_Europe_BCSE_R.ppt#344,27, GPSC – invited PV Industry Associations and next steps

- ii. IEA – PVPS (International Energy Agency Photovoltaic Power Systems) Program
- iii. Alliance for Rural Electrification (ARE)

Reference: http://www.epia.org/03DataFigures/Presentations/SEMICON_EUROPA_2006.pdf

Current European Market Potential until 2010 (2015)

Assumption: quick introduction of an EU-wide Feed-in tariff system

Country	Population (million)	2004 Market (MW)	Potential 2010 (MW)	(2015) (MW)
Germany	80	450	600	≤ 1,000
France	60	5.87	100	≥ 500
UK	60	1.9	50	≥ 500
Italy	60	4.3	200	≥ 1,000
Spain	40	11.8	200	≥ 1,000
Greece	10	1.3	100	≥ 500
Benelux / Austria	30	20.83	150	≥ 700
Rest of EU-15	60	1.26	-	-
New EU states	75	0.2	100	≥ 100
Total	455	410.5	Up to 1,500	≥ 5,000
Japan	130	277	1,200	ca. 4,500

Reference:

RWE SCHOTT Solar GmbH

EurObserv'ER, Photovoltaic Energy Barometer 2005

Policy documents that provide the background for the deployment of renewable energies in general and photovoltaics in particular:

- 1) White Paper for a Community Strategy and Action Plan sets a target of 3 GW³ installed PV capacity by 2010 (1997 White paper for a Community Strategy and Action Plan. Energy for the future: Renewable sources of energy. COM(97)599 final 26/11/1997. Figures relate to EU 15)
- 2) Green Paper Towards a European Strategy for the Security of Energy Supply sets the target to double renewables from 6% in 1996 to 12% in 2010 (Green paper: Towards a European strategy for the security of energy supply: COM (2000)769 final, 29/11/00)
- 3) Directive on Electricity Production from Renewable Energy Sources (RES-e) has the objective to increase the share of green electricity from 14 to 22% by 2010 (Directive 2001/77/EC, 27/09/2001 on the promotion of electricity produced from renewable energy sources in the internal electricity market (RES-e Directive))

European policy goals are targeted at the following:

- 1) Increasing the diversity of energy supply sources and security of supply for Europe
- 2) Reducing the effects on climate change
- 3) Contributing to the sustainable economic growth of the world's economy and developing countries
- 4) Developing a strong European high-tech industry in the field of renewable energies and ensuring its leading role in the world arena.

Regulatory framework for PV in EU-25 and Switzerland (2004)

Austria	Feed-in tariff paid for 20 years with cap of 15 MW, but only for systems installed in 2003 and 2004 (cap was already reached after four weeks); 0.6 €/kWh < 20 kW, 0.47 €/kWh > 20 kW
Belgium	Feed-in tariff: 0.15 €/kWh
Cyprus	Feed-in tariff: 0.12 – 0.26 €/kWh and investment subsidies up to 55% for private investors and up to 40% for companies.
Czech Republic	Feed-in tariff: 0.2 €/kWh for one year; reduced VAT and subsidies of 30% (private: < 2 kW; legal entity investors: < 20 kW); planned Renewable Portfolio Standard (RPS).
Denmark	No specific PV programme, but settlement price for green electricity.
Estonia	Feed-in tariff: 0.07 €/kWh; RPS for electricity (11% by 2005, including large hydro); green certificates
Finland	Investment subsidy up to 40%.
France	Feed-in tariff: 0.15 €/kWh for systems < 1 MW for 20 years in continental France, 0.30 €/kWh in Overseas Department and Corsica; 5.5% VAT on investments on existing buildings, 15% tax credit for individual tax payers (40% in 2005).
Germany	Feed-in tariff for 20 years with built-in annual decrease of 5% from 2005 onward. For plants (not buildings and sound barriers), the decrease will be 6.5% from 2006 onward. The second REE injection law has been approved by the German Federal Chamber, the Bundesrat: 0.46 €/kWh minimum; on buildings and sound barriers 0.57 €/kWh (< 30 kW), 0.55 €/kWh (> 30 kW) and 0.54 €/kWh (> 100 kW), for façade integration there is an additional bonus of 0.05 €/kWh.
Greece	Feed-in tariff: 0.08 €/kWh on islands and 0.07 €/kWh on the mainland. Grants for 40-50% of total cost. Holds only for commercial applications >5 kW, no grants for domestic applications.
Hungary	Feed-in tariff: 0.073 €/kWh until 2010, soft loans; tax reduction, investment and R&D subsidies for RES (private: max 1 k€; companies: max 140 k€; annual funding: 1.2 M€).
Ireland	Alternative Energy Requirement tender scheme (no targets for PV).
Italy	Investment subsidy, feed-in law was passed in February 2004 but regulations and tariffs are not defined yet (expected for 2005).
Latvia	Feed-in tariff: double the average sales price (c 0.15 €/kWh), for 8 years, then reduction to normal sales price; RPS for electricity (6% by 2010); national investment programme for RES since 2002; “soft” loans granted by the Latvian Environmental Investment Fund.
Lithuania	Feed-in tariff: 0.056€/kWh
Luxembourg	Feed-in with quota (1% of total energy consumption). For systems < 50 kW: municipalities 0.25 €/kWh and private investors: 0.45 €/kWh (after the revision of the law in January 2004); in addition investment subsidies up to 40% possible (this was also reduced for systems > 10 kW).
Malta	No specific PV programme yet, but reduced VAT 5% instead of 15%.
The Netherlands	Feed-in tariff: 0.068 €/kWh
Poland	Tax incentives: no customs duty on PV and reduced VAT (7%) for complete PV systems; soft loans (3%) for up to €650,000, max. 5 years and subsidies up to 50% of total costs. April 2004 law: tariffs for all RES-e have to be approved by the regulator; RPS for electricity (2.85% in 2004 and 7.5% in 2010)
Portugal	Feed-in tariff: 0.41 €/kWh (systems < 5 kW) and 0.224 €/kWh (> 5 kW). Investment subsidies and tax deductions.
Slovakia	No specific PV programme. Tax deduction on income earned. RE exempt from income tax for 5 years; “soft” loans (granted on case-by-case basis)

Slovenia	Feed-in tariff: 0.37 €/kWh (systems < 36 kW) and 0.065 €/kWh (> 36 kW) for 10 years; soft loans; subsidies: up to 40% of costs for off-grid PV, plus 10% for SMEs, plus 10% if PV sole electricity source
Spain	New feed-in law passed in March 2004, which went into effect immediately. 0.396 €/kWh < 100 kW (previously limited to 5 kW systems); > 100 kW 0.216 €/kWh. Duration of payment 25 years, with payment on 80% of rated power output beyond that. The decree has also lifted the 50 MW cap, being now 150 MW
Sweden	No specific PV programme. Electricity certificates for wind solar, biomass, geothermal and small hydro. Energy tax exemption.
Switzerland	Net metering with feed-in tariff of min. 0.15 CHF/kWh (0.10 €/kWh); investment subsidies in some cantons; promotion of voluntary measures (solar stock exchanges, green power marketing).
United Kingdom	Investment subsidies in the framework of a PV demonstration programme. Reduced VAT.

Reference: <http://ec.europa.eu/research/energy/pdf/vision-report-final.pdf>

(adapted from A. Jäger-Waldau, H. Ossenbrink, H. Scholz, H. Bloem and L. Werring, 19th European Photovoltaic Solar Energy Conference and Exhibition, Paris, June 2004; S.Pietruszko (PV-NAS-NET coordinator), private communication)

Appendix 19

Bibliographic Entry	Result (w/surrounding text)	Standardized Result
<i>Earth Science</i> . McGraw-Hill, 1999.	"Sputnik 1 was an experiment to show that artificial satellites could be made. Today, thousands of artificial satellites are in orbit around the Earth."	thousands
<i>World Book Millennium</i> . Chicago: World Book, 2002.	"The Soviet union launched the first artificial satellite, Sputnik, in 1957. Since then, the United States and many other countries have developed, launched and operated satellites. Today, more than 2,000 satellites are orbiting the Earth."	> 2,000
<i>World Book</i> . Chicago: World Book, 2004.	"The Soviet Union launched the first artificial satellite, Sputnik 1, in 1957. Since then, the United States and about 40 other countries have developed, launched, and operated satellites. Today, about 3,000 useful satellites and 6,000 pieces of 'space junk' are orbiting Earth."	3,000 (useful) 6,000 (space junk)
Andrew P. <u>Famous Satellites</u> . St. Mary's HS, Manhasset, NY.	"As I mentioned earlier, Sputnik 1, which was launched in 1957, became the earth's first artificial satellite. This truly marked the beginning of the space age. There are now about 5,000 artificial satellites orbiting the earth."	> 5,000
Paul Butterworth and David Palmer. <u>The Number of Artificial Satellites in Orbit</u> . Ask a High Energy Astronomer. 1998.	" There have been about 4000 launches (some with multiple payloads) and my guess is that several hundred of the satellites involved are still active"	~ 4,000

Calculation of space solar market

Number of satellites orbiting space:

Reference: <http://hypertextbook.com/facts/2004/VadimBlikshiteyn.shtml>

From Boeing website:

http://www.boeing.com/defense-space/space/bss/launch/980031_001.pdf

Total number of communication satellites in space = 86 + 164 = 250 satellites

Consider the total number of satellites orbiting space to be 3000.

Solar cells required per solar array = 80 x 60 x 4 = 19,200 solar cells

Assuming a retail price of US\$300 per solar cell and a 20 year lifetime,
Space solar market = 3,000 x 19,200 x 300 / 20 = US\$ 864 million / year.

Appendix 20

Estimated cycle time for single graded substrate wafer (Ge)

UHVCVD reactor (batch reactor, 25 wafers per run):

Wafer cleaning: 0.25 hour

Pump down time required (x2): 0.5 hour x 2 (15 min to 10^{-4} Torr, 15 min to 10^{-9} Torr)

Total thickness of graded buffer = 12 μm at 4 $\mu\text{m/h}$ x 25 wafers requiring total of 75 hours

Pump up time required (x2): 0.1 hour x 2

Time required for CMP process at 50% grading (3 wafers at a time): $9 \times 5 =$ 0.75 hour

Total time required for single graded substrate wafer:

77.25 hours for 25 wafers or 3.09 hr / wafer

LPCVD reactor:

Wafer cleaning: 0.25 hour

Pump down time required (x2): 1/60 hour x 2

Total thickness of graded buffer = 12 μm at 1 $\mu\text{m/min}$ requires a total of 0.2 hours

Pump up time required (x2): 1/60 hour x 2

Time required for CMP process at 50% grading: 1/12 hour per wafer

Total time required for single graded substrate wafer: 0.6 hour per wafer

Estimated cycle time for single solar cell

p++ GaAs contact layer (1000 Å)	$\sim 1 \times 10^{19}$
p+ $\text{In}_{0.47}(\text{Al}_{0.7}\text{Ga}_{0.3})_{0.53}\text{P}$ window (300 Å)	$\sim 2 \times 10^{18}$
p+ $\text{In}_{0.48}\text{Ga}_{0.51}\text{P}$ emitter (500 Å)	$\sim 2 \times 10^{18}$
n $\text{In}_{0.48}\text{Ga}_{0.51}\text{P}$ base (5500 Å)	$\sim 7 \times 10^{16}$
n+ $\text{In}_{0.47}(\text{Al}_{0.7}\text{Ga}_{0.3})_{0.53}\text{P}$ back surface field (300 Å)	$\sim 2 \times 10^{18}$
n++ GaAs TJ (250 Å)	$\sim 2 \times 10^{19}$
p++ GaAs TJ (250 Å)	$\sim 2 \times 10^{19}$
Ge (300Å)	uid
n+ SiGe substrate	$\sim 1 \times 10^{18}$

Pump down time (15 mins for 10^{-4} Torr): 0.25 hour

Total thickness = $30+50+550+30+25+25+40+500+2050+100+200=3600$ nm at 2 $\mu\text{m/h}$
= 1.8 hour

Pump up time required: 1/60 hour

Top GaAs contact layer at 1µm/h, 100 nm thickness requires 0.1 hour
Additional time required solar cell*: 2.07 hours (limiting step for LPCVD grown wafer)
Additional time required for only GaAs wafer*: 0.37 hours

*assume UV exposure to minimize carbon contamination and thermal anneal after oxide desorption is not required. (20 mins each)

For 3 years at 90% efficiency, 365 days a year, 24 hours a day = 23,652 hours,
At 3.09 hours per wafer gives 7,654 Ge wafers (UHVCVD)
At 0.6 hours per wafer gives 39,420 Ge wafers (LPCVD)

At 3.09 hours per wafer gives 7,654 GaAs wafers (UHVCVD limited)
At 0.6 hours per wafer gives 39,420 GaAs wafers (LPCVD limited)

At 3.09 additional hours per solar cell gives 7,654 solar cells (UHVCVD limited)
At 2.07 additional hours per solar cell gives 11,426 solar cells (MOCVD limited)

Estimated production costs required*:

*note that MBE use was for initial research publication and thus obsolete. For the purposes of the cost model the timing required for the MEE step is considered to be done using the MOCVD machine.

Ge production:

UHVCVD machine: US\$1,000,000
Cleanroom space: US\$1,440,000 (25 m² @ US\$2,000/m²/month, 3 years)
2 operators: US\$108,000 (US\$1,500/month x 3 years)
Miscellaneous: US\$100,000
CMP machine: US\$500,000

Total cost: US\$3,148,000

LPCVD machine: US\$750,000
Cleanroom space: US\$1,440,000 (25 m² @ US\$2,000/m²/month, 3 years)
2 operators: US\$108,000 (US\$1,500/month x 3 years)
Miscellaneous: US\$25,000
CMP machine: US\$500,000

Total cost: US\$2,823,000

Solar cell production additional costs:

MOCVD machine: US\$600,000
1 operator: US\$54,000 (US\$1,500/month x 3 years)
Miscellaneous: US\$60,000
Additional cost: US\$714,000

Production cost per wafer (assume 50% cost payback in 3 years, 6”):

For UHVCVD deposited Ge wafers, cost price of US\$205.65 per wafer

For LPCVD deposited Ge wafers, cost price of US\$35.81 per wafer

For UHVCVD deposited GaAs wafers, cost price of US\$252.29 per wafer

For LPCVD deposited GaAs wafers, cost price of US\$44.87 per wafer

For UHVCVD limited solar cell production, cost price of US\$252.29 per wafer

For MOCVD limited solar cell production, cost price of US\$154.78 per wafer

Production cost per wafer (assume 100% cost payback in 3 years, 6”):

For UHVCVD deposited Ge wafers, cost price of US\$411.29 per wafer

For LPCVD deposited Ge wafers, cost price of US\$71.62 per wafer

For UHVCVD deposited GaAs wafers, cost price of US\$504.58 per wafer

For LPCVD deposited GaAs wafers, cost price of US\$89.74 per wafer

For UHVCVD limited solar cell production, cost price of US\$504.58 per wafer

For MOCVD limited solar cell production, cost price of US\$309.56 per wafer

Production cost per wafer (US\$, assume equal cost to area ratio, 50% payback, including silicon wafer price):

	4 inch	6 inch	8 inch	12 inch
UHVCVD Ge	\$101.40	\$245.65	\$405.60	\$912.60
LPCVD Ge	\$25.91	\$75.81	\$103.66	\$233.24
UHVCVD GaAs	\$122.12	\$292.29	\$488.51	\$1,099.16
LPCVD GaAs	\$29.94	\$84.87	\$119.76	\$269.48
UHVCVD Solar	\$122.12	\$292.29	\$488.51	\$1,099.16
LPCVD Solar	\$78.79	\$194.78	\$315.16	\$709.12

Actual wafer prices and estimates

Actual prices quoted from: <http://www.waferworld.com/>

Silicon:

4 inch: US\$10

6 inch: US\$40

8 inch: US\$40

12 inch: US\$90 (estimate based on same cost per unit area)

Germanium:

1 inch: US\$100

2 inch: US\$200

4 inch: US\$400

6 inch: US\$900 (estimate based on same cost per unit area)

8 inch: US\$1600 (estimate based on same cost per unit area)
 12 inch: US\$3600 (estimate based on same cost per unit area)

GaAs:
 2 inch: US\$300
 4 inch: US\$100
 6 inch: US\$200
 8 inch: US\$400 (estimate based on same cost per unit area)
 12 inch: US\$900 (estimate based on same cost per unit area)

Profit per wafer (US\$, assume equal cost to area ratio, 50% payback, including silicon wafer price):

	4 inch	6 inch	8 inch	12 inch
UHVCVD Ge	\$298.60	\$654.35	\$1,194.40	\$2,687.40
LPCVD Ge	\$374.09	\$824.19	\$1,496.34	\$3,366.76
UHVCVD GaAs	-\$22.12	-\$92.29	-\$88.51	-\$199.16
LPCVD GaAs	\$70.06	\$115.13	\$280.24	\$630.52

Selling price of solar cells at various efficiencies and sizes as a function of incident solar radiation levels

Cost of PV module: US\$37,629.42 at \$7.52 per W installed by Borrego Solar in San Diego
 Reference: http://www.unep.fr/energy/act/re/fact_sheet/docs/pv.PDF

Breakdown of related costs (1 Euro = 1.2544 US\$):

- 1) Installation (0.088 / W): US\$ 439.04
- 2) Power inverter (0.414 / W): US\$ 2,069.76
- 3) Module assembly (0.301 / W): US\$ 1,505.28
- 4) Solar cell assembly (0.514 / W): US\$ 2,571.52

Reference: www.rebuildsandiego.org/docs/RebuildPV_Program_Data.xls

Total solar cell cost = US\$31,043.82 (for all solar cells in system)

The rate at which solar radiation reaches a unit of area in space in the region of the Earth's orbit (solar constant) is $1,366 \text{ Wm}^{-2}$.

Reference: <http://rredc.nrel.gov/solar/spectra/am0/ASTM2000.html>

Of the energy received, roughly 19% is absorbed by the atmosphere, while clouds on average reflect a further 35% of the total energy. The generally accepted standard is for peak power of about $1,000 \text{ W/m}^2$ at sea level.

Reference: <http://www.nrel.gov/srri/overview.html>

For North America the average power of the solar radiation lies somewhere between 125 and 375 W/m².

Reference: <http://www.nrel.gov/gis/solar.html>

Assume the solar radiation received in San Diego is 200 W/m².

At solar radiation power of 200 W/m² (North America average):

Number of wafers required: (concentrator substrate size 1 cm²)

	Efficiency				
Wafer diameter	13%	18.6%	28.3%	32% (500x)	38.9 (550x)
4 inch	37,261	26,042	17,116	31	23
6 inch	16,561	11,575	7,608	14	11
8 inch	9,316	6,511	4,279	8	6
12 inch	4,141	2,894	1,902	4	3

Selling price per wafer:

	Efficiency				
Wafer diameter	13%	18.6%	28.3%	32% (500x)	38.9 (550x)
4 inch	\$0.83	\$1.19	\$1.81	\$839.02	\$1,349.73
6 inch	\$1.87	\$2.68	\$4.08	\$1,826.11	\$2,822.17
8 inch	\$3.33	\$4.77	\$7.25	\$3,104.38	\$5,173.97
12 inch	\$7.50	\$10.73	\$16.32	\$6,208.76	\$10,347.94

Assumption:

Area of solar cell is largest circumscribed square in a wafer used.

FLATCON™ cells are at 500x concentration and area of 0.031 cm²

World record concentration assume to be 550x concentration and an area of 1 cm²

Reference:

<http://www.spectrolab.com/DataSheets/TNJCell/utj3.pdf>

http://www.ise.fraunhofer.de/english/press/pi_2005/pdf/04e_ISE-Flyer_Flatcon_Technology.pdf

H.S. Lee et. Al., *Field Test and Analysis: The behaviour of 3-J Concentrator cells under the control of cell temperature*, http://homepage.mac.com/nekins/syracuse/pdf/31sttpvsc_lee.pdf

Calculation of savings through the use of graded substrates

Total epitaxial thickness: 12 μm (0.0012 cm)

Density of Si: 2330 kg/m³ (2.33 g/cm³)

Density of Ge: 5323 kg/m³ (5.323 g/cm³)

Reference: www.webelements.com

Launch payload cost: US\$20,000 per pound (US\$44 per g)

Reference: <http://www.nasa.gov/centers/marshall/news/background/facts/lct.html>

Calculation of cost saving through the use of graded substrate (with grading)*

Radius (cm)	Area (cm ²)	Thickness (cm)	Density g/cm ³	Density g/cm ³	Weight (g) Si	Weight (g) (Ge)	Weight difference	cost / g (US\$)	Cost (US\$)
10.16	324.2928	0.06	2.33	5.323	9.07	20.71	11.6473	44	486.86
15.24	729.6588	0.06	2.33	5.323	20.40	46.61	26.2064	44	1,095.43
20.32	1297.171	0.06	2.33	5.323	36.27	82.86	46.5892	44	1,947.43
30.48	2918.635	0.06	2.33	5.323	81.61	186.43	104.826	44	4,381.72

*assume original thickness 600 μm, thin to 20% which is 120 μm total thickness. For graded substrates the thickness of the original silicon substrate is 108 μm with a 12 μm graded buffer. The germanium substrate is just thinned down to 120 μm from its initial 600 μm.

Calculation of cost for 120 μm weight of graded buffer

Radius (cm)	Area (cm ²)	Thickness (cm)	Density g/cm ³	Density g/cm ³	Average density	Weight (g)	cost / g (US\$)	Cost (US\$)
10.16	324.2928	0.06	2.33	5.323	3.8265	1.48909	44	65.52
15.24	729.6588	0.06	2.33	5.323	3.8265	3.35045	44	147.42
20.32	1297.171	0.06	2.33	5.323	3.8265	5.95635	44	262.08
30.48	2918.635	0.06	2.33	5.323	3.8265	13.4018	44	589.68

From cost model for FLATCON™ solar modules,

From cost price of FLATCON™ solar cells (US\$ 2,885.12), maximum cost for solar cells of various sizes*:

Wafer diameter	Various solar cell costs		
	FLATCON™	UHVCVD	LPCVD
4 inch	\$93.06	\$122.12	\$70.06
6 inch	\$206.08	\$292.29	\$115.13
8 inch	\$360.64	\$488.51	\$280.24
12 inch	\$721.28	\$1,099.16	\$630.52

Wafer diameter	Profit per wafer	
	UHVCVD	LPCVD
4 inch	-\$29.06	\$24.00
6 inch	-\$86.21	\$33.18
8 inch	-\$127.87	\$84.38
12 inch	-\$377.88	\$99.68

*Assuming the FLATCON™ cost was calculated for an incident solar power of 200 Wm⁻²

Cost model conclusions:

The sale of Ge and GaAs on graded substrate wafers is profitable because of the high cost of these wafers relative to Si wafers. Besides the use of UHVCVD to prepare GaAs on graded substrate wafers, UHVCVD and LPCVD can otherwise be used to prepare Ge and GaAs wafers and has been shown to be a profitable enterprise.

Without the use of concentrator technology, graded substrates are unable to enter the residential PV market because equipment cost adds to wafer cost and throughput is not high.

Even without the use of concentrator technology, solar cells grown on graded substrates are at an advantage when comparing to existing solar cells grown on Ge substrates because of the substantial weight savings that more than offsets the additional weight cost caused by the grading.

To compete with existing solar concentrator systems such as FLATCON™, wafers should be produced at larger sizes for higher profit margins.

Annual profit for solar cells retailing in space solar market

Assume 50% initial capital payback in 3 years at interest rate of 20%, retail price of 340% and 190% of production cost for LPCVD and UHVCVD respectively.

	Weight savings	LPCVD Solar cost	UHVCVD Solar cost	LPCVD Profit	UHVCVD Profit
4 inch	\$486.80	\$70.06	\$122.12	\$853,872.60	\$529,667.01
6 inch	\$1095.43	\$115.13	\$292.29	\$1,403,173.74	\$1,267,739.67
8 inch	\$1947.43	\$280.24	\$488.51	\$3,415,490.39	\$2,118,798.14
12 inch	\$4381.72	\$630.52	\$1,099.16	\$7,684,609.62	\$4,767,350.03

Profit for solar cells retailing in residential PV market*

	LPCVD Solar cost	UHVCVD Solar cost	32% FLATCON™	World record 38.9%	LPCVD Profit (32%)	LPCVD Profit (38.9%)
4 inch	\$70.06	\$122.12	\$93.07	\$125.44	\$23.00	\$55.38
6 inch	\$115.13	\$292.29	\$206.08	\$262.28	\$90.95	\$147.15
8 inch	\$280.24	\$488.51	\$360.64	\$480.85	\$80.40	\$200.61
12 inch	\$630.52	\$1,099.16	\$721.28	\$961.71	\$90.76	\$331.18

* before considering interest rate on capital investment and also percentage of production cost taken as profit. Profits in these tables refer to maximum profits for same utility.

Appendix 21

Commercialization Potential of compositionally graded $\text{Ge} - \text{Si}_{1-x}\text{Ge}_x - \text{Si}$ substrates for solar applications

Presenter: Johnathan Goh
Thesis advisor: Professor Eugene A. Fitzgerald

"The use of solar energy has not been opened up because the oil industry does not own the sun."

- Ralph Nader

Outline of presentation

- Compositionally graded substrate technology
- Applications of graded substrate technology
- Alternative / Competing technologies
- Intellectual Property
- Financing
- Business Models

- Questions and Answers

Compositionally graded substrate technology

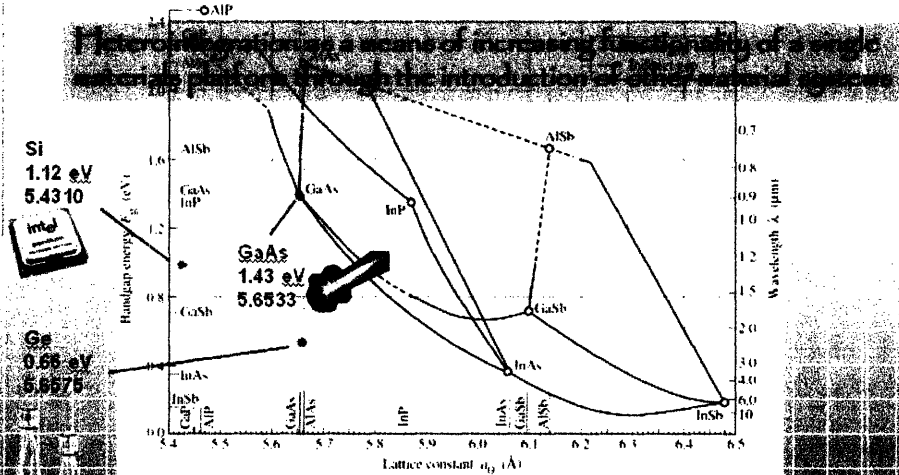

Fig. 7.6. Bandgap energy and lattice constant of various III-V semiconductors at room temperature (adapted from Tien, 1988).

Compositionally graded substrate technology

Ge (100) surface offcut by 6° towards the (111) plane to suppress APD formation at the GaAs/Ge interface

Ge cap layer (~100 nm) critical for smooth starting surface, $>640^\circ\text{C}$ anneal for ~20 mins

CMP step to remove the deepest "crosshatch" features that cause dislocation pinning and pileup formation, and thus promote efficient dislocation glide without unnecessary nucleation of new dislocations

Advantage of Si over traditional Ge or GaAs:

1. Higher thermal conductivity
2. Lower weight
3. Lower material cost
4. Leverage on manufacturing base of Si

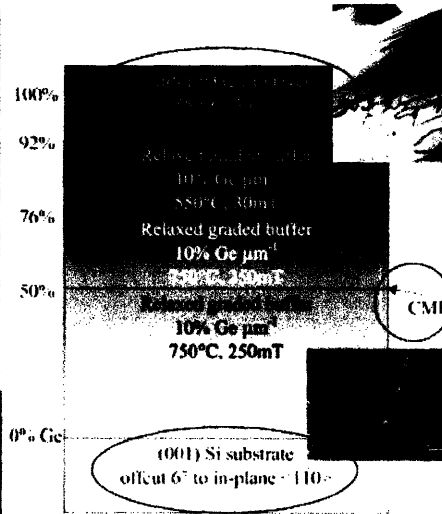

Compositionally graded substrate technology

Ohmic contacts were made to the p-type GaAs contact layer using either unannealed Cr:Au or annealed Zn:Au.

The antireflection coating (ARC) consisted of $\text{MgF}_2\text{-ZnS-MgF}_2$ and was deposited in a thermal evaporator.

The p+/n polarity was chosen based on earlier results showing it to be much less susceptible to TDD-related carrier lifetime reduction and depletion region recombination issues than n+/p cells

The SSMBE GaAs initiation procedure suppresses antiphase domain (APD) formation and minimizes cross-diffusion, which allows the use of thin GaAs buffer layers of less than 200 nm.

p++ GaAs contact layer (1000 Å)	$\sim 1 \times 10^{19}$
p+ $\text{In}_{0.47}\text{Al}_{0.7}\text{Ga}_{0.3}\text{P}$ window (300 Å)	$\sim 2 \times 10^{18}$
p+ $\text{In}_{0.49}\text{Ga}_{0.51}\text{P}$ emitter (500 Å)	$\sim 2 \times 10^{18}$
n $\text{In}_{0.49}\text{Ga}_{0.51}\text{P}$ base (5500 Å)	$\sim 7 \times 10^{16}$
n+ $\text{In}_{0.47}\text{Al}_{0.7}\text{Ga}_{0.3}\text{P}$ back surface field (300 Å)	$\sim 2 \times 10^{18}$
n++ GaAs TJ (250 Å)	$\sim 2 \times 10^{19}$
p++ GaAs TJ (250 Å)	$\sim 2 \times 10^{19}$
Ge (300Å)	uid
n+ SiGe substrate	$\sim 1 \times 10^{18}$

Applications of graded substrate technology

- * On-chip optical interconnects
 - Monolithic laser, waveguide and photodetector elements
 - Single crystal Ge epitaxy on Si / thermal budget issues
- * Integrated III-V semiconductor lasers on Si
 - Demonstration of GaAs / AlGaAs laser on Si
 - Device lifetime of 15 minutes (TDD: $2 \times 10^6 \text{ cm}^{-2}$)
 - Improvements to TDD, best reported $\sim 6\text{-}8 \times 10^5 \text{ cm}^{-2}$
- * Solar cells
 - Dual junction $\text{In}_{0.49}\text{Ga}_{0.51}\text{P} / \text{GaAs}$ solar cells on Si
 - Active area efficiency 18.6%, total area efficiency 16.8%

The Competition

- Heterointegration strategies / manufacturing process
 - Fundamentally limited
 - Unsuitable for this application
 - Less explored / immature
 - Patents held by **Encore** and **Spectrolab**
- Solar cell technology
 - Si (crystalline, polycrystalline, amorphous)
 - II-VI eg. CdTe
 - Multijunction (top / edge illuminated), thermophotovoltaics
- Established solar cell companies
 - US, Japan, China / Taiwan, European Union

Alternative heterointegration strategies / manufacturing processes

- Fundamentally limited
 - Direct growth, Liquid Phase Epitaxy (LPE) growth
 - Lattice / thermal expansion coefficient mismatch, impurities
- Unsuitable for this application
 - Finite area growth, growth on compliant substrates
 - Area too small for solar application, compliance may be an issue
- Less explored / immature
 - GaP / GaInP, Sb, Ge/Sn, Perovskites
 - Be constantly updated on new developments in these areas
- Patents held by **Encore** and **Spectrolab**
 - Monolithic bypass diode, contact formation, system packaging
 - Be careful to prevent copyright / patent infringement

Solar cell technology – maximum theoretical efficiency calculations

Maximum theoretical efficiency limits:

Single junction – 30% (semipirical Shockley-Queisser limit)

Multi-junction (top illuminated):

68.2% – 1 sun illumination

86.8% – 45,900 suns, ∞ cells

Multi-junction (edge illuminated):

64% – 1 sun illumination

77% – 1,000 suns

81% – 10,000 suns

Thermophotovoltaics

54% unconcentrated sunlight

85.4% concentrated sunlight

Thermodynamic limit of 93%

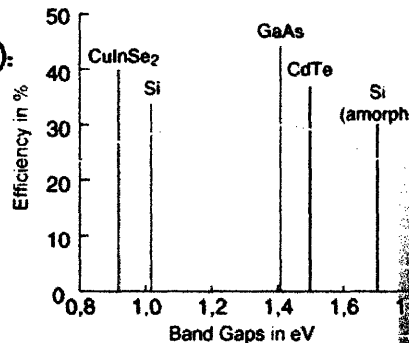

The world market

Space solar market: US\$ 864 million (est.)

Residential PV market: US\$ 14.3 billion (2006 est.)

US 500 MW cumulative in 2005

Germany: ~600 MW in 2004

France 20 MW

Austria 20 MW

China: 1 GW by 2007

Japan: 1462 MW cumulative in 2005

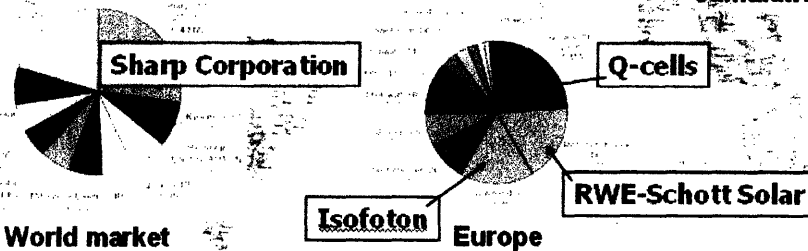

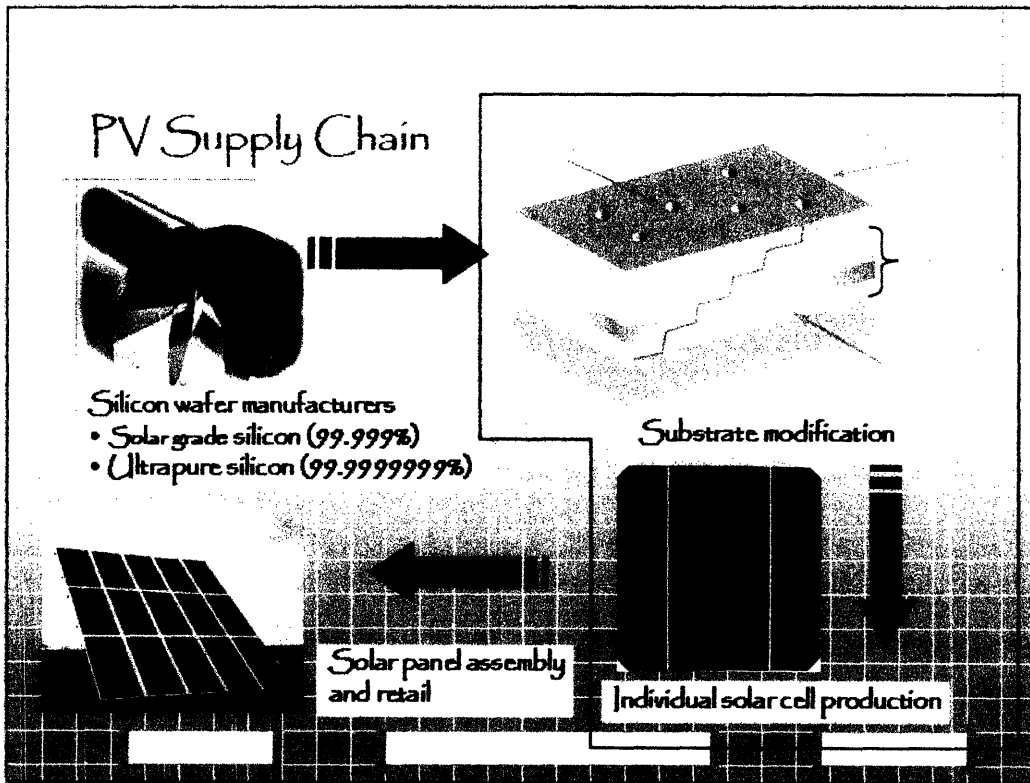
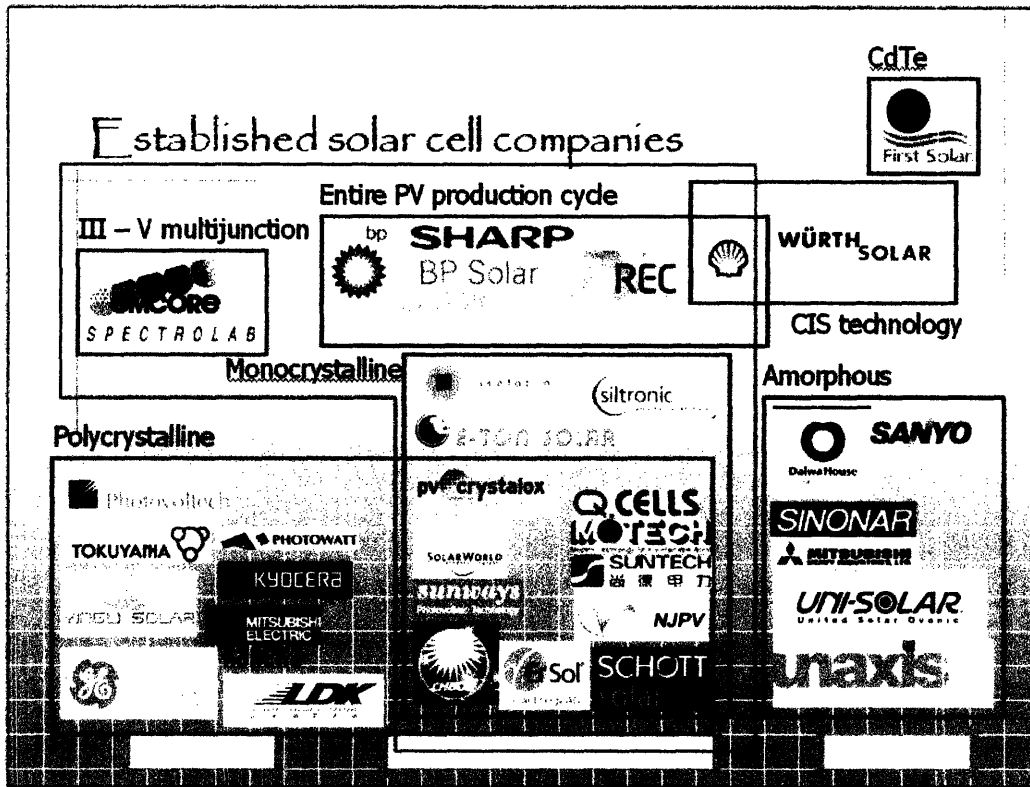

Production strategy

- Retail choice of Ge or GaAs virtual substrates or complete multijunction solar cells
- Consider a 3 year time period for 50% capital repayment
 - 10 year equipment lifetime gives 4 years of solely profits
- Estimated production volume:
 - 2,654 (UHVCVD) or 39,420 (LPCVD) Ge wafers
 - 2,654 (UHVCVD) or 39,420 (LPCVD) GaAs wafers
 - 2,654 (UHVCVD) or 11,426 (LPCVD) Solar cells
- Production costs:
 - UHVCVD at US\$3.148 M
 - LPCVD at US\$ 2.323 M
 - MOCVD solar cell production US\$714,000

Graded substrate retail profitability analysis

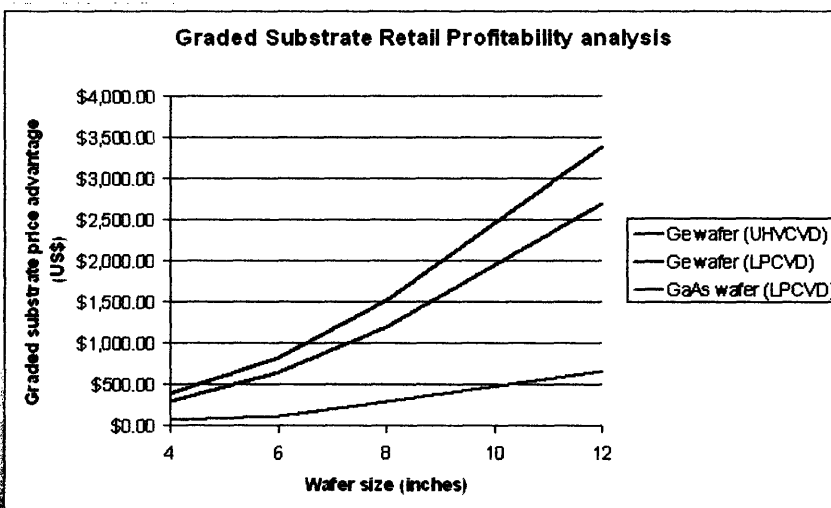

Graded substrate retail profitability analysis

- Retail at > 50% discount over commercial retail price
- Interest rate on capital investment of 10%

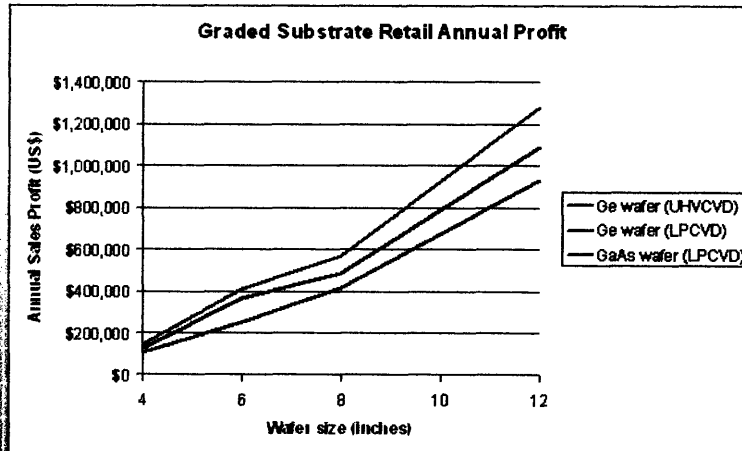

Solar cell retail profitability analysis

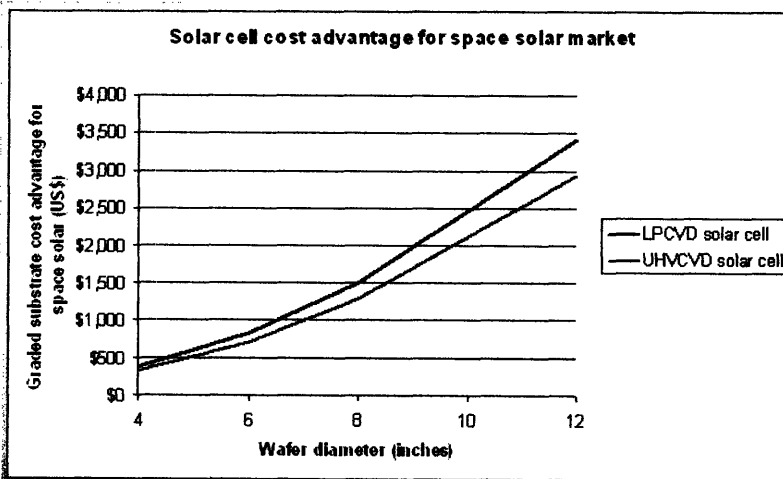

Graded substrate retail profitability analysis

- Retail at > 50% discount over commercial retail price
- Interest rate on capital investment of 20%

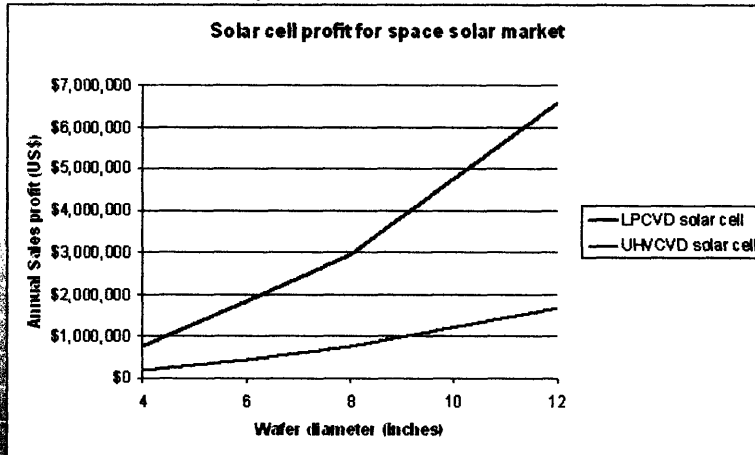

Solar cell retail profitability analysis for residential PV market

- Solar cell production cost from US\$70-1100

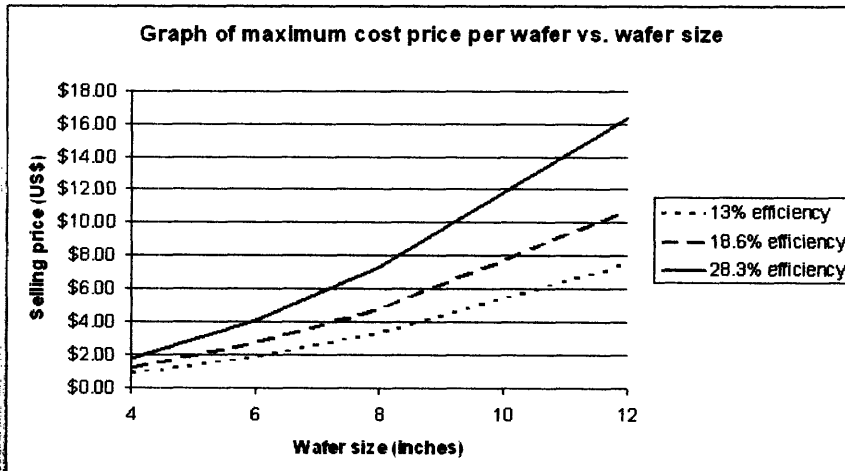

Increasing competitiveness in the residential PV market

- Limiting cost is the substrate wafer
 - Overcome this cost hurdle using concentrating lens
- Small solar cell area required (1 cm² or less)
 - Number of 1cm² in a 4 inch wafer: 51 (464 for 12")
- Benefits:
 - Cheaper plastic lens in place of expensive substrate area
 - Highest efficiency 38.9% achieved at 489 suns
- Research problems:
 - Sun tracking
 - Focussing lens design
 - Heat dissipation

Increasing competitiveness in the residential PV market

- Products utilizing concentrating lens are already out in the market: eg. SunBall™
 - 500x Fresnel concentrator lens
 - Dual axis tracking system
 - Uses Spectrolab triple junction solar cells
 - 3 kW system for US\$ 9561.23
- FLATCON™ system
 - 5 kW system for US\$ 14,926.96

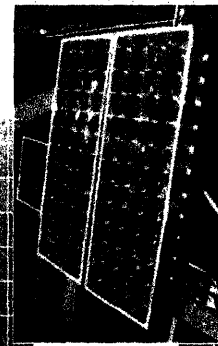

Solar cell retail profitability analysis for residential PV market

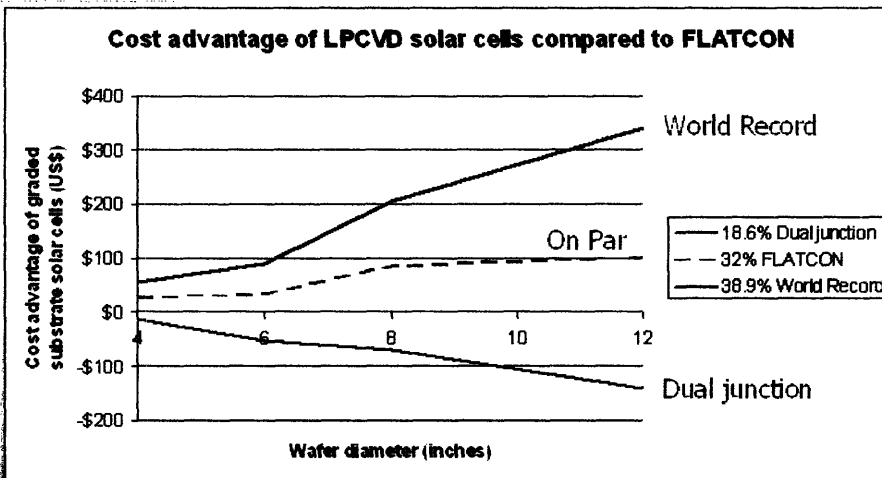

Potential solar cell retail profit analysis for residential PV market

- * Retail at > 14% discount over commercial retail price
- * Interest rate on capital investment of 10%

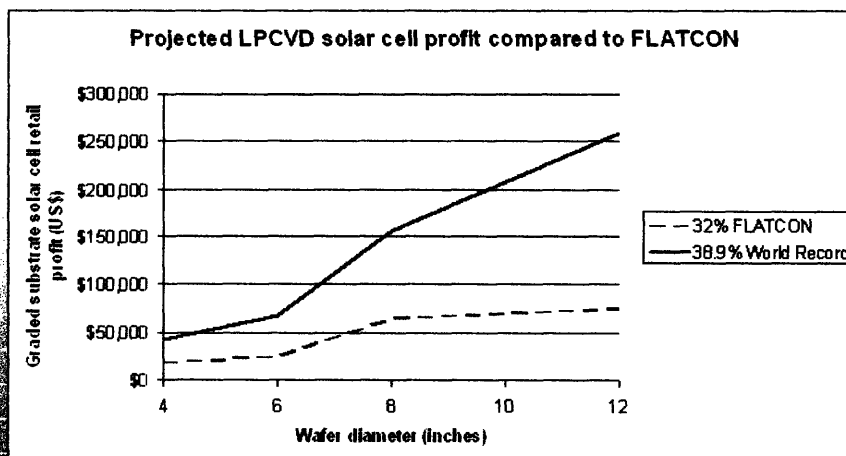

Issues in going forward

- Initial capital barrier – min. US\$2.33 M required
 - Unknown entry into saturated markets, competing with established players (for both space and terrestrial solar)
 - Low chances of survival
- Unique design for III-V triple junction solar cells required that is distinct from existing patents, equivalent or better performance
 - Substantial time / investment required for design optimization
 - Market will respond reluctantly to marginal improvement in efficiency compared to monocrystalline Si at 17%
 - Spectrolab dual junction GaInP₂/GaAs cell: 21.5% efficiency

The Business proposal

- Three target audience groups
 - Monocrystalline Si / III-V multijunction vendors
 - Solar module assembly
 - Silicon wafer providers
- Strategic partnerships based on:
 - Development trends into next-generation PV technology
 - Established distributor network
 - Strong branding and regional / global presence

Solar cell vendors

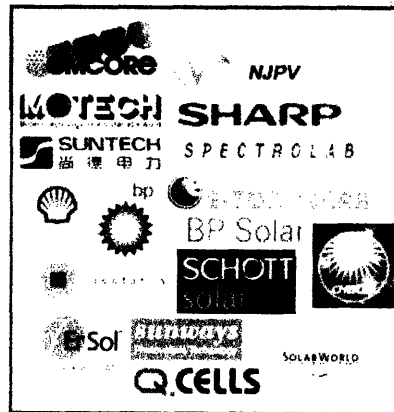

Solar module assembly

Silicon wafer providers



The Business proposal

- Sale of intellectual property (IP):
 - Technology has the potential of providing larger, more expensive wafers at a premium over smaller, cheaper ones
 - Potential substantial improvement to be brought to existing PV industry through the introduction of III-V materials
 - Successful proof of concept in dual junction graded substrate
- Consider Sharp Corporation (400 MW / year):
 - For a preliminary trial of 0.01% of production (40 kW / year)
 - At a license fee of 1% of the sales price
 - Income of approximately US\$ 244,000 ~ 333,600 / year

Conclusion

- Strongest selling point is to make available III-V's high efficiency on cheaper, stronger and larger Si substrates
- Annual projected profits range:
 - US\$ 18,000 ~ 250,000 for solar cells
 - US\$ 103,000 ~ 1,090,000 for Ga_x wafers
 - US\$ 142,000 ~ 1,280,000 for GaAs wafers
- The 'P's of market Penetration:
 - Partnership with silicon wafer producers to tap on existing distribution networks
 - Positioning ourselves as graded substrate retailers to solar companies
 - Producers of complete PV systems through MSK Corporation
 - Providers of intellectual property

The future is bright,
just concentrate!

