

INSPECTION AND INSTRUMENTATION OF BRIDGES

by

Smita Niranjana Shah

B.S. Civil Engineering
Northwestern University, 1994

Submitted to the Department of Civil and Environmental Engineering in Partial
Fulfillment of the Requirements for the Degree of

MASTER OF SCIENCE IN CIVIL AND ENVIRONMENTAL ENGINEERING
AT THE
MASSACHUSETTS INSTITUTE OF TECHNOLOGY

FEBRUARY 1996

© Smita Niranjana Shah
All Rights Reserved

The author hereby grants to MIT permission to reproduce
and to distribute publicly paper and electronic
copies of this thesis document in whole or in part.

Signature of Author: _____
Department of Civil and Environmental Engineering
January 19, 1996

Certified by: _____
Oral Buyukozturk
Professor of Civil and Environmental Engineering
Thesis Supervisor

Accepted by: _____
Joseph M. Sussman
Chairman, Departmental Committee on Graduate Studies

MASSACHUSETTS INSTITUTE
OF TECHNOLOGY

FEB 26 1996

LIBRARIES

Inspection and Instrumentation of Bridges

by

Smita Niranjana Shah

Submitted to the Department of Civil and Environmental
Engineering on January 19, 1996 in Partial Fulfillment of the
Requirements for the Degree of Master of Science in
Civil and Environmental Engineering

ABSTRACT

Condition data, material properties, and design considerations are necessary variables for predicting structural performance. Currently, condition data for highway bridges is primarily obtained by visual inspection methods. There is also some assistance from the expanding technology of nondestructive testing and evaluation. The problem is that neither of these methodologies provides continuous, accurate, and global evaluation of bridges. With the nation's present state of bridges at a 40% structurally deficient rating, it is necessary to consider a process which has these characteristics. Instrumentation is this process.

Instrumentation would provide continuous, accurate, and global evaluation of bridges, as well as facilitate understanding of structural behavior. It would provide information on structural trends which, when combined with analytical models, could predict more accurately and quickly the future behavior of the structure. It would also allow for identification of potential failure conditions before they become large problems.

The application of instrumentation is discussed and exemplified through the use of a case study of the Sunshine Skyway Bridge in Tampa, Florida. This case study demonstrates the benefits of instrumentation in verification of structural behavior. The methods of instrumentation are identified and evaluated in this case study.

An evaluation discussing instrumentation in general and the success of the Skyway Bridge instrumentation program is presented in following, including the potential future use of instrumentation as a common practice. Finally, the conclusions and future implications are presented.

Thesis Supervisor: Oral Buyukozturk
Title: Professor of Civil and Environmental Engineering

For my Mom, my Dad, and my brother

ACKNOWLEDGMENTS

This thesis is the finale of my MIT career- at least for now. MIT has been an amazing experience for me, and I would like to thank all of those people who have given me support in both my thesis and during my one and a half years here. I will attempt to avoid what I like to call the “Oscar Syndrome-” noting everyone and anyone who has ever even been a small part of my life, independent of their contributions to my thesis- in writing these acknowledgments. It has been, however, at least equally as difficult to write these acknowledgments as to write this entire thesis. I find myself grateful to so many people yet unable to accurately express this appreciation due to the natural limitation encountered in translating these feelings into words. The gratitude I have can only be basically touched by the words that follow.

I would first like to thank my family, which includes my Mom, Dad, and little brother (whom I fondly refer to as “Skinny”). They have always stood by everything I have done- whether or not they agreed with the action. An incident that particularly comes to mind is that trying time last year when I broke my leg skiing. None of them wanted me to go. But, I needed them, so my Mom and Skinny both came to Boston to take care of me. Even my Dad managed to not complain *too much* about the entire incident. He did send me flowers with a “told you not to go skiing” card, however (thanks, Dad). This is a wonderful example of the care that they invest in me. They encourage me to always reach for the stars, provide plenty of advice and humor, and I love them for everything.

There are several people who have specifically contributed to my thesis. I would first like to thank my advisor, Professor Buyukozturk, for his guidance and enthusiasm. The quality of this thesis would not have reached this level without his characteristic precision and patience. I have learned a lot from working with him. I would also like to thank all of the people at Florida Department of Transportation for all of their help in providing me with information on the Sunshine Skyway Bridge.

I would like to thank a wonderful group of people within the department who have opened their doors to me and watched me wear a hole in their rug with all my worries. Cynthia Stewart, Pam Maus, Pat Vargas, Danielle Severino, Charlie Helliwell and Pat Dixon have continually supported me through everything, whether it was writing the thesis or just relaxing and hanging out. Professors Jerome Connor and John Miller have both very patiently listened to me, advised me, and supported me with regard to my classes and my career plans. Thank you.

There are a number of people, both within MIT and without, who have contributed to my happiness and have listened to me during all the high and low points of not only my thesis but my entire MIT career. I thank them, because they can not even begin to understand the value of their friendship to me.

I want to insert a small note to at least two friends who have already said or will definitely say my acknowledgments are cheesy and/or nerdy: Nick, Sumul, I don’t care. I felt like saying all of this stuff, and, frankly, at least I did not cop out by using bullets.

TABLE OF CONTENTS

ABSTRACT	2
ACKNOWLEDGMENTS	4
TABLE OF CONTENTS	5
LIST OF FIGURES	6
LIST OF TABLES	7
1. INTRODUCTION	8
1.1. BRIDGE CONCERNS.....	8
1.2. HISTORY.....	9
1.3. LIFE CYCLE COSTS.....	10
1.4. DETERIORATION MECHANISMS.....	11
1.5. PROBLEM STATEMENT.....	12
1.6. OBJECTIVES AND FORMAT.....	13
2. CONDITION EVALUATION OF BRIDGES	14
2.1. OVERVIEW.....	14
2.2. STRUCTURAL EVALUATION TECHNIQUES.....	15
2.3. NATIONAL BRIDGE INVENTORY.....	20
2.4. BRIDGE MANAGEMENT SYSTEMS.....	23
2.5. STATE OF THE ART.....	26
2.6. DISCUSSION.....	27
3. INSTRUMENTATION	29
3.1. INTRODUCTION.....	29
3.2. INSTRUMENTATION CRITERIA.....	31
3.3. SENSORS.....	32
3.4. DATA ACQUISITION SYSTEMS.....	34
3.5. SUMMARY.....	36
4. CASE STUDY: SUNSHINE SKYWAY BRIDGE	37
4.1. BACKGROUND.....	37
4.2. SUPERSTRUCTURE.....	39
4.3. STRUCTURAL CONCERNS.....	49
4.4. FIELD INSTRUMENTATION.....	50
4.5. INSPECTION AND MAINTENANCE PROGRAM.....	68
4.6. LAB AND FIELD TESTS ON SEGMENTS.....	69
4.7. ANALYTICAL MODEL.....	71
4.8. RESULTS: PREDICTED VS. MEASURED.....	78
4.9. DISCUSSION.....	83
5. EVALUATION	85
5.1. CONTINUOUS MONITORING.....	85
5.2. SUNSHINE SKYWAY BRIDGE.....	87
6. CONCLUSION	89
6.1. SUMMARY.....	89
6.2. CONCLUSION.....	90
6.3. FUTURE IMPLICATIONS.....	91
REFERENCES	92
SELECTED BIBLIOGRAPHY	95

LIST OF FIGURES

FIGURE 4-1: LOCATION OF SUNSHINE SKYWAY BRIDGE	41
FIGURE 4-2: ELEVATION OF SUNSHINE SKYWAY BRIDGE.....	42
FIGURE 4-3: CABLE STAY DETAILS.	44
FIGURE 4-4: PYLON PROFILE AND SECTION FOR CENTER SPAN	45
FIGURE 4-5: TYPICAL PIER CONCRETE OUTLINE- PROFILE VIEW	46
FIGURE 4-6: CROSS SECTION OF A SEGMENT.....	47
FIGURE 4-7: PIER DESIGNATIONS	52
FIGURE 4-8: INSTRUMENTED BRIDGE SEGMENTS FOR PIER P3N.....	53
FIGURE 4-9: INSTRUMENTED BRIDGE SEGMENTS FOR PIER P1N.....	54
FIGURE 4-10: INSTRUMENTED BRIDGE SEGMENTS FOR PIER 1S	54
FIGURE 4-11: DISTRIBUTION OF CARLSON STRAIN METERS IN A TYPICAL BRIDGE SEGMENT	56
FIGURE 4-12: MEASURED STRAIN HISTORY OF SEGMENT P1N1S DURING ERECTION SEQUENCE: SEGMENT IS UNDER DEAD LOAD	57
FIGURE 4-13: MEASURED STRAIN HISTORY OF SEGMENT P1N1N DURING ERECTION SEQUENCE: SEGMENT IS UNDER DEAD LOAD	58
FIGURE 4-14: DISTRIBUTION OF TEMPERATURE MEASUREMENT LOCATIONS IN A BRIDGE SEGMENT	60
FIGURE 4-15: LOCATION OF STRAIN METERS IN PYLON P1N	61
FIGURE 4-16: OBSERVED STRAINS FOR PYLON, 8 FT. ABOVE ROAD.....	62
FIGURE 4-17: OBSERVED STRAINS IN PYLON 85 FT. ABOVE ROAD.....	63
FIGURE 4-18: LOCATION OF THERMOCOUPLES IN PYLON P1N	65
FIGURE 4-19: SCHEMATIC DRAWING OF ADAS	67
FIGURE 4-20: PROGRAM CRACK FLOW CHART	72
FIGURE 4-21: IDEALIZED PYLON CROSS SECTION 8 FT. (LEFT) AND 85 FT. (RIGHT) ABOVE ROADWAY.....	75
FIGURE 4-22: IDEALIZED SEGMENT CROSS SECTIONAL PROPERTIES, CENTRAL SPAN, SEGMENTS 1-3, 94-96, RIGHT OF PIER P1N.....	76
FIGURE 4-23: IDEALIZED SEGMENT CROSS SECTIONAL PROPERTIES FOR SPAN 1N AND 1S, SEGMENTS 1-4, NORTH OF PIER 1N AND SOUTH OF PIER 1S	77
FIGURE 4-24: CALCULATED STRAIN IN PYLON, 8 FT. ABOVE RD.	80
FIGURE 4-25: CALCULATED STRAIN IN PYLON, 85 FT. ABOVE ROAD.....	81

LIST OF TABLES

TABLE 2-1: NBI CONDITION AND APPRAISAL RATINGS.....21
TABLE 4-1: MATERIAL PROPERTIES OF THE SUNSHINE SKYWAY BRIDGE.....48
TABLE 4-2: SUMMARY OF INSTRUMENTATION ON SUNSHINE SKYWAY BRIDGE.....55
TABLE 4-3: PHYSICAL PROPERTIES OF SEGMENTS AFTER SHORT TERM TESTS.....70
TABLE 4-4: THERMAL STRAINS.....83

1. INTRODUCTION

1.1. BRIDGE CONCERNS

Bridge structures represent a substantial investment for their owners. This investment occurs not only during the initial design and construction phases, but in the entire life cycle costs of the structure. Thus, it has become a growing cause of concern to bridge owners that one out of every three bridges in the United States are rated structurally deficient or functionally obsolete by bridge inspectors, and require major improvements ranging from deck replacements to complete reconstruction.¹ The substantial costs arising from these rehabilitation procedures have led to a complete reexamination of the bridge design, construction, and condition assessment processes.

¹ Grant, Albert A. "Civil Infrastructure Systems: The Big Picture." *Journal of Infrastructure Systems*, June 1995, pg. 78-81

1.2. HISTORY

There are currently four primary bridge design criteria: safety, serviceability, economy, and elegance. Each one of these criteria has developed through history with the progress of construction materials and structural theory. It is during the Industrial Revolution in the early 1800's that the first major advancements in bridge design occurred.²

Prior to the Industrial Revolution, bridges were built mostly from stone and timber. They were designed by master builders using empirical guidelines and built from simple tools and traditional materials. But by the end of the Industrial Revolution, bridges began to be designed by engineers using the newly developed theory of structures. They were being built from stronger, lighter, industrially produced materials. The postal coach network and the proliferation of railroads placed increased demand for considerations of economy, strength, and faster construction time in bridge design. The first material to satisfy these requirements was industrially produced iron.

Cast iron was the first industrially produced iron to be used in bridge design. Unfortunately, there were material limitations due to brittleness. This implied a use only in compression. The development of wrought iron resolved this problem to some degree; it had greater tensile strength and ductility. This revolutionized the use of the hanging cable for suspension bridges, which proved to allow longer span bridge structures.

Both iron and its predecessor, steel, had the benefits of strength, having light weight, and allowing a speedy construction. They also had the disadvantages of requiring high maintenance costs and a high ratio of live load to dead load. The latter became a problem because bridges needed to be strengthened when traffic requirements changed and heavier objects such as trains would be the users.³

² Menn, C., *Prestressed Concrete Bridges*, Birkhauser Verlag AG Basel, Germany, 1990.

³ Ibid.

The development of Portland Cement solved this problem: it proved to be maintenance free.⁴ The heavy weight of concrete reduced the ratio of live load to dead load. Since concrete and masonry had similar behavioral properties, the structural theory had already been established. But as the use of concrete developed through the use of reinforcing bars and prestressing strands and its structural application advanced, its limitations were discovered. These limitations included creep, shrinkage, and cracking of the concrete, and corrosion, fire, and impact damage of steel reinforcement.

Through this brief history, it is clear that the development of the new materials and their improved properties led to new structural theories, design and understanding of bridge structures. This allowed for maximized use of the attributes of each material's properties, as well as a wider variety of options to satisfy each of the design criteria.

1.3. LIFE CYCLE COSTS

The design objectives of safety, serviceability, economy, and elegance are traditionally constrained by restrictions on construction time, requirements on locations of piers in water, environmental protection regulations, noise level restrictions, and traffic safety. There is currently a movement by Federal Highway Administration and the United States Department of Transportation to include in this criteria the entire life-cycle cost.

Life cycle cost includes the construction, operation, amortization, and demolition. The annual operating costs, which include maintenance, inspection, and rehabilitation, typically comprise 1% of the construction cost.⁵ Clearly, then, the maintenance and rehabilitation of bridge structures represents a significant portion of bridge costs during their life spans. Many times this is the situation because any rehabilitation measures to be taken are found after a defect has already reached a critical level. The cost of fixing this is greater than the cost of fixing a defect that is still minor. But bridge owners do not invest in minor repairs

⁴ Menn, C., 1990, *Prestressed Concrete Bridges*, Birkhauser Verlag AG Basel, Germany, pg. 50

⁵ Menn, C., 1990, *Prestressed Concrete Bridges*, Birkhauser Verlag AG Basel, Germany, pg. 50

until it is absolutely necessary.⁶ Part of this is the lack of current funds, the other part of this was an ignorance to the degree of the problem it would cause. This ignorance is waning as awareness to the debilitated state of the nation's infrastructure increases.

The increased funding requirements, proportional to the rehabilitation requirements, led to the development of the National Bridge Inspection Standards and Bridge Management Systems, both of which are discussed in detail in the next chapter. These systems supplement the availability of models at the network level. They attempt to ensure the effective use of available funds and articulate the influence of various funding levels on the bridge network. The problem is that the current inspection and maintenance procedures which supply information for these systems are rather subjective, and do not always immediately locate problems and deficiencies.

1.4. DETERIORATION MECHANISMS

There are a variety of deterioration mechanisms on concrete bridges. There are the typical problems with steel reinforcement and concrete cracking. Concrete deficiencies can arise from creep, shrinkage and thermal expansion and contraction. Deficiencies also differ with separate portions of the bridge. Bridges can be divided into different "portions," including foundations, piers, abutments, deck, and bearing. Common problems with foundations occur due to scour, abutments typically experience thermal cracks and spalling, bearings need to be replaced due to excessive wear, and the deck experiences many problems, ranging from concrete disintegration to vehicular impact damage. The deck can experience problems arising from freeze/ thaw action; water seeps into cracks in the deck and expands the cracks when the water freezes. Saltwater creates a series of problems, starting from crack expansion on the deck to penetration through the bridge deck to the girders. The presence of the saltwater on the girders permits corrosion

⁶ Gerard Grippo, "Structural Condition Monitoring of Concrete Bridges." Term Paper, MIT, November 1994.

of steel reinforcement, which may cause the loss of the girder section if not properly maintained.

1.5. PROBLEM STATEMENT

There are tools currently available for bridge condition evaluation which could provide more accurate data on the current as well as future state of bridges. But these tools have not been implemented to a large extent. Current inspection procedures are largely qualitative in nature. Data provided through inspections is limited by an inspector's accessibility to bridge members and his visual interpretation. The advent of nondestructive testing and evaluation (NDT/ NDE) procedures has facilitated the examination of in situ behavior of members and behavior not ascertainable through traditional visual inspection. The evolution of NDT equipment and methods has simplified the application of these procedures, making the equipment smaller and easier to use in the field, also at a reduced cost. Thus, their use is not always precluded by a lack of training or a lack of funds. This equipment assists in the provision of a more quantitative assessment of bridge structures through inspection, but still does not resolve the problems of subjectivity and of the periodic nature of inspection.

Continuous monitoring is the ideal way to resolve the problems of bridge inspection. The periodic evaluations become continuous, allowing problems to be caught as they occur, and the qualitative and subjective assessment becomes quantitative. Continuous monitoring permits verification of design assumptions and spurs future developments of innovative concepts. Improving technology has developed instruments that can be implemented during construction or even post construction. The development and improvement of automatic data acquisition systems (ADAS) expedites the process of data gathering from all the instruments. It facilitates an instantaneous collection and can even be used to analyze the structure's behavior on the spot. Instrumentation could not only assist in inspection, but could improve engineers' understanding of bridges by the provision of the continuous data. In short, it would be a valuable tool to integrate into the

normal inspection routine. Its current application has been very limited, however, because it is expensive and because its application requires a high degree of technical expertise.

1.6. OBJECTIVES AND FORMAT

The purpose of this study will be to demonstrate that research into the use of instrumentation as a viable inspection method and design tool will be a worthwhile project.

The following chapters will accomplish this goal by:

- describing current bridge evaluation procedures and discuss their problems,
- discussing the attributes of instrumentation technology and describe the components of a comprehensive program,
- using a case study to show the benefits of instrumentation, above and beyond its comparison to inspection and maintenance, and
- presenting an evaluation of the program and case study.

In the end, a summary will be presented to review the issues presented and their future implications.

2. CONDITION EVALUATION OF BRIDGES

2.1. OVERVIEW

Bridges represent a substantial investment to owners, not only in terms of the initial cost, but in the entire maintenance, repair, and replacement costs as well. In fact, the latter costs can prove to be much greater over the life of a bridge than the first cost. Until now, bridges were designed and built considering only the initial cost, neglecting the substantial post-construction costs involved. The current highway bridge inspection program is adapting itself to consider these life cycle costs.

The Federal Highway Bridge Administration developed the highway bridge inspection program after the collapse of the Silver Bridge in 1967. The program functions to identify deficient bridge structures and a potential strategies for cost effective maintenance, repair, and replacement. The program requires biennial inspections (the general requirements of

the inspection and evaluation are set forth in the Code of Federal Regulations, 23 CFR 650C⁷), from which data is collected then compiled into the National Bridge Inventory (NBI) by the Federal Highway Administration (FHWA). The analysis of this data is the basis on which Congress establishes federal funding through programs such as the Highway Bridge Replacement and Rehabilitation Program. If the states have inspection and rating systems different from the FHWA's and federal aid is desired, they are required to convert their results to the FHWA standard.

There is a trend towards improving the nation's infrastructure management program. Current inspection and maintenance programs are proving to be too qualitative. States are finding that there is not enough money to maintain bridges at a functional and safe standard. The number of bridges needing to be repaired has increased, draining what available funding there is.⁸ With the Intermodal Surface Transportation Efficiency Act (ISTEA) of 1991,⁹ the states are now required to have a bridge management system to facilitate data gathering. The IESTA is credited towards moving many states to the current state of the art. It is expected to not only reduce life cycle costs, but also to lengthen the life of the bridge.

This chapter will describe the fundamentals of bridge inspection, some of the innovations in the field, and the inaccuracies thereof.

2.2. STRUCTURAL EVALUATION TECHNIQUES

Highway bridge evaluations are performed by bridge inspectors. Since inspectors can not immediately assess the condition of the entire structure with current techniques, the inspector traditionally does a piece by piece analysis. The decks, bearings, girders,

⁷ Gerard Grippo, "Structural Condition Monitoring of Concrete Bridges." Term Paper, MIT, November 1994.

⁸ de Brito, J., Branco, F.A., and Ibanez. M. "A Knowledge Based Concrete Bridge Inspection System." *Concrete International*, February 1994, pg. 59

⁹ Yanev, B.S. "Bridge Management: A Panel Discussion." *Restructuring America and Beyond Structures Congress*, Proceedings v 1, 1995, pg. 666-667

abutments and piers are just some of the bridge sections evaluated to establish the structural integrity of the entire structure. There are three fundamental techniques which a bridge inspector is likely to use to successfully evaluate the structure: inspection, analysis, and nondestructive testing.¹⁰ Each is described in the following sections.

2.2.1 INSPECTIONS

Inspections are performed by a bridge engineer to determine the functional capacity of the bridge. On-site structural evaluations are executed on a biennial basis to establish the foundation for load rating analysis, maintenance actions, and rehabilitation programs. The first time a bridge is inspected, inventory items are collected, including location, type, age, and geometry. An initial analysis is also performed, predicting the load capacity and other fundamental structural conditions. Thereafter, data is collected regularly. The inspections consist of observations and measurements to check the condition of the bridge and identify any changes from the previous inspection. Sometimes nondestructive methods are used to take a more in depth look at the bridge.

2.2.2 NONDESTRUCTIVE TESTING

Nondestructive Testing is a method of determining the in situ deterioration of concrete. Its application has been extended to supplement traditional visual bridge inspection techniques, because NDT furnishes a more accurate reading of the behavior of concrete than traditional visual examination. The location and identification of surface and subsurface flaws that are not typically accessible to humans can be established through NDT. Based on a survey performed of all state chief bridge engineers, it was established that the NDT methods commonly used in the field include dye penetrant testing, magnetic particle testing, and ultrasonic testing.¹¹ There are other techniques- such as radiography,

¹⁰ Gerard Grippo, "Structural Condition Monitoring of Concrete Bridges." Term Paper, MIT, November 1994.

¹¹ Based on survey of state bridge engineers performed at MIT

acoustic emission, and radar- as well, but these were the ones identified as most commonly used and are described in following.

DYE PENETRANT TESTING

The dye penetrant testing method enhances both visual and photographic examination. It is generally used to define the extent and size of surface flaws in steel members. The surface of the selected test area is cleaned, and a liquid dye is applied and allowed time to be drawn into any discontinuities. Excess penetrant is removed and a developer is applied to the surface to draw out the dye in the discontinuities. A clear visual representation of any flaws is thus provided. This method is commonly used by bridge inspectors since it is relatively inexpensive and easy to use, thereby eliminating the necessity of highly skilled operators. The disadvantage is that subsurface cracks remain undetectable, and the presence of small cracks can not be accurately determined.

MAGNETIC PARTICLE TESTING

Magnetic particle testing functions similarly to dye penetrant testing in that it assists in locating surface defects, and is not as effective in establishing subsurface flaws. It is able to detect surface gouges, cracks, and pinholes.

The procedure requires magnetization of the surface being inspected by a pair of current carrying metal prods. Iron powder is then applied over the surface. The particles align themselves with the flux lines of the magnetic field induced on the surface. Cracks or other surface discontinuities of the member cause interruptions in the magnetic field. The iron particles respond by accumulating on the irregularities, providing a visual indication of the discontinuity. Magnetic particle testing can detect some subsurface defects, such as voids, inclusions, and cracks that lie near the surface. The limitation of this test method is the need for a ferromagnetic surface.

ULTRASONIC TESTING

Ultrasonic testing differs from the previous two methods in that it is the only commonly used method that can detect with a reasonable degree of certainty subsurface flaws. The test method introduces sound waves by a transducer into a structural member. High voltage electric pulses drive the piezoelectric crystal in the transducer, causing the crystal to resonate and produce short bursts of high frequency of vibrations. Acoustic mismatches at discontinuities reduce the amount of energy returned to the transducer, allowing the detection of irregularities. The crystal in the search unit converts the reflected sound back into electrical pulses, which can be interpreted to evaluate the flaw characteristics. The amplitude of the return signal provides a measurement of the flaw size. The time of travel through the member indicates the distance of the flaw surface. The testing equipment is portable, expediting its use in field inspections.

Ultrasonic testing has seen an increased application for in service inspection of pins in pin and hanger assemblies. The problem with this method is that it is difficult to establish whether the defect is due to wear from corrosion or just a crack. It also requires a highly skilled operator for data interpretation.

RADIOGRAPHIC METHOD

The Radiographic Method is not frequently used,¹² but is gaining a more wide spread application in inspection. In the survey performed of all state chief bridge engineers, many noted that while there is not much of a current application, they are awaiting developments on this technology.

The process aims x-rays at a material, and records the portion of x-rays passing through the material. When there are cracks and cavities present, the absorption of radiation at the areas of these defects is less than in the surrounding solid region.

¹²Based on survey of state bridge engineers.

Linear accelerators have gotten smaller in size and thus more portable. This has extended the use of radiography in the inspection of in-service bridge members. They are capable of penetrating through one meter of concrete and 0.35 meters of steel.

The advantages of this method include the ability to reveal internal features of an object, and can be useful for examination of members with complex geometries. The disadvantages are that it still does not reveal the depth of the defect, is expensive, and radiation safety is an issue.

2.2.3 GLOBAL EVALUATION

Typically, the condition data gathered from inspections and testing are used to supplement mathematical models of deterioration and strength. These models are used to analyze and predict the behavior of the structure. Many idealizations and assumptions are generally involved in these models to account for unknowns, which could result in over-design or under-design, essentially undermining the accuracy of the models. The use of the subjective inspection procedures further detracts from the accuracy of the model.

The previous techniques provide information primarily for individual components of the bridge structure. For a global evaluation, dynamic analyses are performed on the structure.

The dynamic response of a bridge can provide clues as to structural damage of a bridge. Modal parameters are a function of the physical characteristics- stiffness, damping, and mass- of the bridge. Structural damage alters these properties and the resulting mode shapes, frequencies, and damping ratios. Accuracy of analyzed mode shapes for natural vs. damaged structures are important. The variance can be so small that it is necessary to be as accurate as possible. Modal changes on the order of 0.01 Hz are significant for purposes of safety inspection. A close examination through modal analysis can provide quite a bit of information on the strength and safety of the structure; it has

been established that similar cracks at various locations in a structure contribute differently to changes in modal parameters.¹³

To evaluate these dynamic characteristics, the bridge can be subjected to a controlled excitation.¹⁴ Controlled excitation can be broken down into two general categories of forces; control forces and random forces. There are three types of control forces: 1) the pull and quick release, which causes an initial displacement of the bridge, 2) the rocket, which generates an initial velocity on the bridge, and 3) the mechanical oscillator, which causes the bridge to resonate. The random forces include wind load, traffic load, and ground motion. Clearly the controlled forces allow for better estimates of the natural frequencies and mode shapes of the bridge than random forces. This information can be related to analysis parameters and provide information on the deterioration of structural safety of the bridge.

The problem with this method is that the application of controlled forces to observe the dynamic response creates an interruption in the function of the bridge. Traffic over the bridge needs to be stopped, as well as any movement below the structure as well.

2.3. NATIONAL BRIDGE INVENTORY

The Federal Highway Administration provides minimum data gathering guidelines from inspections through the National Bridge Inventory (NBI). In order to qualify for federal funding, each bridge owner must fulfill the requirements of the NBI. The NBI contains a wealth of information gathered by bridge inspectors, making it possible to characterize the bridge population and its deficiencies. It contains approximately 100 active data items from which a bridge can be inventoried and rated. Some of the data items pertain to inventory items identifying location, structure type, age, geometry, and classification.

¹³ Chang, K. C., S. Shen, and G. C. Lee. "Modal Analysis Technique for Bridge Damage Detection." *Structural Engineering in Natural Hazards Mitigation*, v 2, 1993, pg. 1083-89

¹⁴ Tang, Jhy-Ping., and Ker-Ming Leu. "Vibration Measurement and Safety Assessment of Bridges." *Journal of the Chinese Institute of Engineers*, vol. 11, no 5, pg. 543-549

Along with this information are ratings, which aids in identification of the deficiencies that determines federal funding eligibility. Each rating is based on a scale of 0-9, failed condition or “bridge closed” to excellent condition or “superior to present desirable criteria.”¹⁵ Ratings are qualitative and do not identify the severity of deterioration in elements. This allows a fairly specific characterization of bridge population and deficiencies. It is important to realize, though, that these ratings are inherently subjective and dependent on the bridge inspector’s judgment and experience. Although the bridge inspector’s characterization of the bridge may include many structural conditions, the reduction to a simple number is subjective. Therefore, the actual serviceability of the bridge cannot be accurately reflected. It is through this database that it has been established that roughly 40% of the 600,000 highway bridges in the United States are deficient.

Item	Title	Description
Condition Ratings		
58	Deck	Overall condition excluding wearing surface, expansion devices, etc
59	Superstructure	Physical condition of structural members excluding bearings, etc.
60	Substructure	Physical condition of piers, abutments, piles, footings, etc.
Appraisal Ratings		
67	Structural Evaluation	Lowest of inventory rating goal for HS load and ADT, superstructure condition, and substructure condition.
68	Deck Geometry	Lower of ratings for width and overhead clearance goals for ADT.
69	Underclearances, vertical and horizontal	Lower of ratings for horizontal and vertical clearance goals for functional class of underpassing route.
71	Waterway Adequacy	Rating for overtopping frequency and traffic delay goal for functional class of route on bridge.
72	Approach Roadway Alignment	Rating for alignment with respect to traffic speed reduction at bridge.

Table 2-1: NBI Condition and Appraisal Ratings.¹⁶

¹⁵ Dunker, Kenneth F., Rabbat, Basile. “Assessing Infrastructure Deficiencies: The Cases of Highway Bridges.” *Journal of Infrastructure Systems*, v 1, n 2, June 1995, pg. 100

¹⁶ Dunker, Kenneth F., Rabbat, Basile. “Assessing Infrastructure Deficiencies: The Cases of Highway Bridges.” *Journal of Infrastructure Systems*, v 1, n 2, June 1995, pg. 101

The condition and appraisal ratings in the National Bridge Inventory establish deficiencies in bridges. The condition ratings are an estimation of deterioration, section loss, excessive cracking, scour and other conditions that can be seen and measured during an inspection. These ratings provide an indication of physical deterioration due to environmental effects and traffic wear. The appraisal ratings in the coding guide are a function of the average daily traffic (ADT) or the functional class of the route. Thus, bridges of the same configuration on a lightly traveled route and a heavily traveled one will receive a higher rating on the lightly traveled route. The ratings and their descriptions are listed in Table 2-1. It is these two classes of ratings that are used to establish the need for federal funding.

Federal funding is established by classifying a bridge as “structurally deficient” or “functionally obsolete.” A structurally deficient bridge is defined as being “restricted to light loads only, is closed, or requires immediate rehabilitation to stay open.” A rating of 4 or less in any of the deck, superstructure, or substructure condition items, and a rating of two or less in structural evaluation or waterway adequacy appraisal items is sufficient to generate a structurally deficient classification.

A functionally obsolete is a bridge on which the “deck geometry, load-carrying capacity, clearance, or approach roadway alignment no longer meets the usual criteria for the system of which it is an integral part.” A rating of 3 or less in any of the structural evaluation, waterway adequacy, deck geometry, under-clearances, or approach roadway alignment appraisals would provoke a functional obsolete classification. It is interesting to note that bridges that could be classified as both structurally deficient and functionally obsolete are automatically excluded from the functionally obsolete category if they are in the structurally deficient one.

The NBI is the fundamental building block of any bridge management system. The NBI establishes the minimum requirements for bridge inventory and assessments. The data provided is an integral part of the bridge management systems.

2.4. BRIDGE MANAGEMENT SYSTEMS

Bridge management systems (BMS) assist owners in the analysis of bridge infrastructure investment. Guidelines have been promulgated by the American Association of State Highway and Transportation Officials regarding BMS.¹⁷ A bridge management system functions to assist in the tracking of a network of structure, form models of its performance, to plan and record maintenance activities, and assess current bridge conditions. The minimum requirements of a BMS are a database and inspection procedures to support it. By using mathematical modeling techniques, the system makes predictions of deterioration and costs, and processes data for determining short and long range budgeting needs.

INTERMODAL SURFACE TRANSPORTATION EFFICIENCY ACT

In 1991, Congress passed the Intermodal Surface Transportation Efficiency Act (ISTEA), mandating that state of the art bridge management system (BMS) should be implemented by all bridge owners, and that all states need to develop and implement systems to manage highway and transportation facilities. The target date for system development and implementation was September 30, 1995. If the date is not met, the United States Department of Transportation could impose sanctions, which could take form in the withholding of 10% of federal funds apportioned to the state.

Life cycle considerations played a significant role in the adoption of the ISTEA. The desire was to:

- **Widen the application of a benefit cost framework to highway preservation decisions.**
- **Increase attention to the benefits of preventative maintenance strategies and other low-capital-cost options to preserving existing infrastructure.**

¹⁷ AASHTO. "Guidelines for Bridge Management Systems," Washington D.C., American Association of State

- Move the service life to be a function of the relative benefits and costs of different design, maintenance, and rehabilitation options for the road and traffic loads in question.

The requirements of the ISTEA have also been looked upon by state DOT's as an opportunity to review their status of their infrastructure and management systems in general. Maintenance management systems are not technically within the ISTEA mandates, but are affected by the entire life-cycle-cost analysis required. The planning, programming, and policy analyses aspects involving these elements of highway infrastructure affect a change in the technical and engineering aspects of the management systems.

REQUIREMENTS

The ISTEA required that the BMS includes a database and an ongoing program for collection and maintenance of the bridge inventory, inspection, cost, and supplemental data needed to support the system. An additional general requirement that the design and engineering of bridges should consider the life-cycle costs of the structure is also emphasized.¹⁸ The BMS should also include procedures to both analyze and optimize the bridge inventory. These procedures should include the ability to:

1. Predict element deterioration
2. Identify feasible actions to improve bridge conditions, safety and serviceability
3. Estimate action cost
4. Estimate expected user cost savings for safety and serviceability improvements
5. Determine least-cost maintenance, repair and rehabilitation strategies for bridge elements
6. Perform a multiperiod optimization to ensure that the minimum life cycle cost is being considered
7. Use feedback from actions taken to update the predictions and cost models
8. Generate summaries and reports as needed for the planning and programming process.

¹⁸ Bettigole, Neal H. "Bridge Management and Life Cycle Cost." *Restructuring America and Beyond Structures Congress, Proceedings v 1, 1995, pg. 668-669*

This evaluation is based primarily on costs, as was the intent in promulgating the ISTEA.

TECHNOLOGY

The FHWA developed PONTIS in response to the ISTEA mandates.¹⁹ PONTIS is a bridge management system that would be capable of estimating and prioritizing the work necessary for bridge rehabilitation, maintenance, and emergency repairs. The program is available to all states, and there are also available several programs to facilitate conversion of condition ratings from other systems to PONTIS. With the implementation of this program, the need for quantitative and accurate methods of structural evaluation becomes more significant. For this reason, the ISTEA is able to have an impact on the technical and engineering aspects of management systems. The DOT is inclined to seek the most effective technology, which naturally involves an exploration of the state of the art technology.

EFFECTS

The ISTEA represents the first application of life cycle cost analysis to highway infrastructure management in the United States. Its effects are to 1) require a planning and programming process in which life-cycle cost analysis can contribute useful information, and 2) require management systems that in fact can provide information. While the awareness of benefit-cost analysis has been around for a long time, the technology to implement them into the bridge management process has not. That is the foresight of the ISTEA.

¹⁹ Yanev, B.S. "Bridge Management: A Panel Discussion." *Restructuring America and Beyond Structures Congress, Proceedings* v 1, 1995, pg. 666-667

2.5. STATE OF THE ART

The convergence of basic trends is leading to a new state of the art in highway management systems.²⁰ There is a demand for system information arising in part from Intermodal Surface Transportation Efficiency Act of 1991. Other contributing factors are shrinking budgets, changes in the demographics of the DOT work force, proposals to privatize highway work, and the general changing composition of the highway program. The rapid evolution of technology is also a major contributor to the development of a new state of the art. The limitations and inaccuracies of current methodologies are being improved upon.

In addition to the ISTEA, the Transportation Research Board, in cooperation with AASHTO and FHWA has performed a research project to identify data acquisition technologies to aid in field inspection.²¹ The technologies simply ensure a more accurate recording, not necessarily a more accurate data assessment. Technology that is currently available for bridge inspection includes: portable hand held computers, electronic clipboards with handwriting recognition, bar-code scanners, voice recognition systems, satellite Global Positioning System, digitized maps, and radio frequency transponders. Some of the more commonly used technology is described in following.

DIGITIZED MAPS/ELECTRONIC CLIPBOARD²²

Roadway feature inventory is generally updated and recorded for a particular location using standard forms- inspection sheets, general supervisor's patrol report, and maintenance improvement cards. Location and dimensions of maintainable features are

²⁰ Markow, Michael J., "Highway Management Systems: State of the Art." Journal of Infrastructure Systems. September 1995

²¹ Hyman, W.A. and R. M. Alfelor and T.M. Alexander. "Field Demonstration of Advanced Data Acquisition for Maintenance Management." National Cooperative Highway Research Program, Report 361, 1993

²² NCHRP. "Field Demonstrations of Advanced Data Acquisition Technology for Maintenance Management." National Cooperative Highway Research Program, Report 361, 1993

the most common attributes measured or determined. The use of a pen-based system with a digitized map display facilitates the recording of attributes of roadway elements.

GLOBAL POSITIONING SYSTEM

Management systems require an accurate description of work location and maintainable features. Satellite global positioning systems (GPS), in conjunction with geographic information systems (GIS), can reduce the time and error involved in measuring distances from a milepost reference marker. GPS receivers allow the determination of location in latitude and longitude coordinates. This location is stored on a digitized map and can be recalled by simply entering coordinates. This system is primarily useful in noting location of structural attributes, such as signs or guardrails.

Each of the previous systems described is useful for accurate recording of data. But these advances do not affect the quality of data gathered. To advance in data acquisition and bridge inspection techniques, measures need to be taken to improve the quality of data gathered.

2.6. DISCUSSION

From the previous discussion, it is clear that there are a few problems with the current process of bridge inspection and maintenance.

One problem with current methodology is that it encourages bridge owners to wait until the bridge has deteriorated before repairs are performed. Federal funding is not available until the bridge has received the status of structurally deficient or functionally obsolete. Research shows that if damage or potential problem spots in bridges are located and treated before they become significant, the total cost to the owner will be lower in the long run.²³ It is also obvious that when one portion of bridge is left to deteriorate, then

²³ Dunker, Kenneth F., Rabbat, Basile. "Assessing Infrastructure Deficiencies: The Cases of Highway Bridges." *Journal of Infrastructure Systems*, v 1, n 2, June 1995, pg. 101

the other members of the structure need to compensate, thereby exerting an increased strain on the structure. The prolonged treatment of the bridge structure simply serves to weaken it, increasing the overall cost of the repairs- when they are finally performed.

Another problem with the current biennial inspection and maintenance procedures serve only to repair a structure once there is already significant damage.²⁴ Some data as to minor irregularities in the structure are provided, and this data may be used in establishing a long term deterioration model for the structure. But this long term model will necessarily include idealizations to account for those periods of time where the structure has not been monitored and data has not been obtained. The data obtained also tends to be somewhat subjective to the bridge inspector's judgment. Therefore, this information is not entirely precise for the purpose of understanding structural behavior. A more continuous monitoring scheme would be desirable to both assist in quantitative analysis and to create a more preventative rather than prescriptive function for bridge inspection and maintenance. One solution is instrumentation.

²⁴ George Hearn. "Structural Engineering Applications in Bridge Management Systems." *Restructuring America and Beyond Structures Congress, Proceedings* v 1, 1995.

3. INSTRUMENTATION

3.1. INTRODUCTION

The application of instrumentation programs has become common in a variety of fields, such as aerospace engineering and geotechnical engineering. This includes not only the use of sensors in inspections or gathering data, but an entire system which takes data from a variety of sensors at one end and feeds out the test report with quality results at the other end. Structural engineering, however, has not seen such a frequent application. The value of its use in this field, particularly in bridge inspections, becomes logical upon reflection.

Changes in physical integrity generally occur over a large period of time, not always instantaneously. There are the incidences of catastrophic failures due to unusual events such as violent weather or elimination of a member through collision. But typically, degradation in physical integrity and load carrying capacity occur through the gradual actions of corrosion, fatigue, and scour. The current periodic nature of inspection and

maintenance does not facilitate a complete and accurate picture of the wearing actions on the bridge. Any resulting analysis includes assumptions and idealizations of behavior since the last time that data was gathered. To produce a more accurate model, it is necessary to develop a continuous monitoring program. Instrumentation supported by data acquisition systems and well developed analytical techniques would be useful in providing an accurate, continuous method of evaluation and improving understanding of bridge behavior due to both ambient and applied loading conditions.

Non-destructive testing and evaluation (NDT/NDE) methods are the state of the art in bridge inspection, allowing for structural flaw detection beyond the capacity of the naked eye. The problem is they do not yet provide for the exact nature and location of structural defects. They do not produce exact data which can be evaluated, and do not do it instantaneously over the course of the structure. NDT is useful primarily in obtaining an approximate location and sense of the deterioration. The application of NDT in facilitating inspections was discussed in the prior chapter.

Instrumentation is currently the only solution to remove the inconsistencies and inaccuracies of inspection and maintenance and to allow continuous, rather than periodic, measurements and assessments. It is the logical solution to the time consuming and often inaccurate calculations that are performed in analyzing a bridge structure. Take the example of a prestressed, segmentally constructed concrete structure, using the balanced cantilever method of construction. Errors in computing prestress losses would not affect the ultimate strength of the flexural member, but could adversely affect the serviceability of the structural member. This would include camber, deflection, and crack control. Precise calculation becomes critical in the balanced cantilever construction method. In this process, cantilevers from adjacent piers are required to meet at mid-span at a prescribed elevation and slope. Thus, the correct time dependent deflections are crucial- an accurate estimation of which requires an accurate assessment of prestress loss.²⁵ Instrumentation

²⁵ Shiu, Kwok-Nam and Henry G. Russell. "Effects of Time- Dependent Concrete Properties on Prestress Losses." *Canadian Journal of Civil Engineering*, vol 14, 1987, pg 649-654.

could furnish values of strain, which, when compared to analytical models, can be back-solved to determine prestress losses.

The segmental construction method results in complex load histories on individual post-tensioned elements. Post-tensioning of newly erected segments inherently relieves a certain portion of prestressing in the previous segments through elastic shortening. Thus, the prestress levels change as construction progresses and estimation of prestress losses after each construction event becomes necessary for control of concrete stress levels and geometry control. This involves a very time consuming and iterative calculation process.²⁶ Using instrumentation supported by a data acquisition program during construction would expedite this process in an accurate manner. With the proper software, the results could be fed directly into an analysis program that would perform the iterations and produce values for any variables desired.

The ensuing chapter presents the general requirements of an instrumentation program, and then attempts to discuss each of these requirements in some detail.

3.2. INSTRUMENTATION CRITERIA

Instrumentation would serve to assist in evaluating structures, making decisions for preventative maintenance, and examining new design techniques. A comprehensive program would require high speed data acquisition systems (DAS), highly sensitive sensors, efficient operating software, and remote control and transfer mechanisms for data collection. This would allow data gathering instantaneously, even in locations which are typically inaccessible by traditional inspection procedures.

The monitoring system should identify damage or deterioration and even issue warnings for repair, rehabilitation, or operation control action until the condition is improved and satisfies operating needs. To do this, the structural condition would need to

²⁶ Shiu, Kwok-Nam and Henry G. Russell. "Effects of Time- Dependent Concrete Properties on Prestress Losses." *Canadian Journal of Civil Engineering*, vol 14, 1987, pg 649-654.

be correlated with stable and measurable indices (natural frequencies, mode shapes, etc.). Changes in the indices need also be correlated with changes in the structural damage or deterioration. The field conditions such as environmental effects, variable loading, and electromagnetic disturbances to the data acquisition process need to be understood to be subtracted from the data to determine the actual deterioration. The baseline of structural indices for consideration of the service environment would establish the sensitivity to the structure and sensors to structural damage and deterioration.

When applying an analytical procedure taking into account the modal properties, it is important to include not only the lower modes in the calculations, but the higher modes as well. Sometimes the lower modes do not exhibit the structure's response to a given excitation, but there is a significant response in the higher modes.

One ambient condition that could have a significant effect on modal properties is the temperature. This is of particular concern when support conditions are altered by temperature. Therefore, it makes sense to include temperature sensors on a continuous monitoring program to allow for thermal effects.

It is very important that the sensors and DAS be designed to withstand the field conditions as well, so continuous data collection and processing can occur with precision.

3.3. SENSORS

There are six major types of sensors used to monitor structural behavior: thermocouples, strain gages, inclinometers, corrosion cells, load cells, and accelerometers.²⁷ Each functions differently within the data gathering and analysis process, and furnishes useful information with regard to the physical integrity of the structure.

²⁷ Gerard Grippo, "Structural Condition Monitoring of Concrete Bridges." Term Paper, MIT, November 1994.

THERMOCOUPLES/ THERMISTORS

Both thermocouples and thermistors are devices used for in situ temperature measurements. A thermistor is a thermally sensitive resistor, usually made of a semiconductor material with a large temperature coefficient of resistance. This allows small changes in the temperature gradient to result in large changes in resistance. This allows for measurements of temperature vs. depth, so it has a more common geotechnical application.²⁸

STRAIN GAGES

The repeated exposure a bridge has to excessive weight capacity causes deterioration of bridges. Strain gages can assist in establishing the number of times a bridge exceeds its load limit capacity. Data gathered here can be processed to obtain physical parameters such as strain, stress, acceleration, and inclination.

INCLINOMETER²⁹

Inclinometers measure absolute attitude and long term trend changes in attitude. This is done by measuring the static deflection/deformation. The structural attitude assists in determining the effects of scour. Research has demonstrated that significant changes occur due to ambient conditions. These changes are large enough to mask changes in traffic loading. Therefore, trend changes need to be monitored corresponding to seasonal changes. Data collection and analysis techniques are needed to subtract the ambient effects to normalize data to accurately reflect attitude changes in traffic loading. This requires database trends to be established for ambient conditions.

²⁸ Rada, Gonzolo R., Aramis Lopez, Gary Elkins, Cheryl Richter, and Brandt Henderson. "Long-Term Pavement Performance Program: Instrumentation Selection and Installation." *Transportation Research Record*. n 1432, 1994, pg. 32-43

²⁹ Terry J. Wipf. "Use of Tilt Sensing Equipment for Monitoring Long-Term Bridge Movement." *Canadian Journal of Civil Engineering*. vol 18, 1991, pg. 1033-1046

CORROSION CELLS

These sensors facilitate the inspection of steel reinforcement in bridges.

ACCELEROMETER

Accelerometers assist in the monitoring of vibration signature response. The results of their calibration for baseline indices can be used to calibrate analytical model as well.

LOAD CELL

Load cell is a weighing device. It utilizes resistive strain gauges, bonded to a piece of steel to which the load is applied. The resulting strain is deduced from the consequent changes in resistance. These are used often to measure structural excitation.

3.4. DATA ACQUISITION SYSTEMS

The heart of any instrumentation program is the automated data acquisition system (ADAS). An ADAS functions to allow for remote access monitoring, reliable measurements, and continuous monitoring, basically providing for complete management of the testing process.

3.4.1 REQUIREMENTS OF ADAS³⁰

The system has seen a greater application in a variety of fields with the realization that physical testing greatly improves quality and productivity. Included in the spectrum of physical testing are transient, dynamic, performance, and static applications. Even within this varied application, a number of common requirements have been found. Seventy to eighty percent of hardware and software requirements are common to a variety of applications. The other 20-30% require variation and customization in terms of real-time,

³⁰ Arun P. Sheth. "Design Considerations: A High Performance Integrated Data Acquisition System." *Proceedings of the 38th International Instrumentation Symposium*, 1992, pg. 409-416

data analysis, networking and test report generation requirements. Until recently, all 100% had to be customized for the user, and did not allow for integration of products from a variety of vendors. This “closed architecture” proved to be too limiting, and the development of “open architecture” has facilitated the use of ADAS.

Hardware and software modules can be selected based on:

- sensor types
- sampling rates and data throughput requirements
- real-time requirements
- data analysis needs
- data storage requirements
- networking and other interface needs.

With these basic requirements the development of an ADAS for bridge instrumentation is understood.

3.4.2 ADAS FOR STRUCTURAL SYSTEMS³¹

Considerations in the design of an ADAS for structural systems should include:

- long term field placement, to protect the device from the environment,
- changes in structural attitude (i.e. tilt of piers, buttresses, roadbeds),
- data on and analysis of acoustic signature,
- data for purpose of relating changes in base resonant frequencies to changes in structural integrity,
- ability to gather data almost instantaneously.

This last point should be emphasized. All instrumentation channels needed to capture the state of the structure at any given point in time should be scanned by the system quickly. There should not be a large time gap between measurements, especially for situations where analysis requires data from all points of the structure at the same time.

The control software for the ADAS is often written by the user, which is typical for computer automated equipment. With the advance of technology, the general user and

³¹ James M. Petty. “Monitoring Performance of Full Scale Structures.” *Natural Hazards Mitigation*, vol 2, pg. 1596-1601

equipment interfacing is improving, but currently the greatest customization of the program is still provided by self created software. It is typically a proprietary program that allows for remote calibration, data acquisition, and operating parameters for each sensor channel to be changed. Such operating parameters would include sampling frequency and sampling time for strain gauges and inclinometers, and triggering conditions for accelerometers.

3.5. SUMMARY

Instrumentation would simply take sensors that are traditionally used for inspection and maintenance, embed them in the structure, and automate them. The continuous data would be useful for analysis, inspection, and verification of design assumptions. Its use can support new designs by its ability to catch problems before they start. The behavior of structures can be strictly monitored, leading to new understandings of behavior and checking of complex mathematical models.

In the following chapter, a case study will be presented to demonstrate the use of instrumentation.

4. CASE STUDY: SUNSHINE SKYWAY BRIDGE

4.1. BACKGROUND

The Sunshine Skyway Bridge is a precast, prestressed concrete, segmentally constructed, cable-stayed bridge in Tampa Bay, Florida. It was built in 1986 to replace a steel truss bridge that had been damaged by a ship impact in 1980. A concrete cable-stayed structure was chosen to replace the old bridge, because of span link considerations and a determination that it would be the most viable, cost effective structure for the aesthetic qualities desired. The cable-stayed design was presented by Figg and Muller Engineers Inc. in both concrete and steel, per the Federal Highway Administration's request. The FHWA felt that allowing both alternatives would encourage competition and low bids. When the bids were opened, it was found that the concrete alternative was lower than the steel by two million dollars. This bridge would be the largest clear span concrete structure.

The bridge cost a total of \$226 million, which includes the contracts for low level trestle approaches, large dolphins to protect the piers, and electronic monitoring and warning systems for motorists and ships.³² The high level portion of the new bridge was bid at 9% below the estimate by Paschen Contractors, Inc., Chicago. With all the extras, the main contract on the bridge cost \$77 million. All the engineering costs for design and redesign were \$13 million, and the construction engineering consultant SKYCEI cost \$14 million.

The single plane fan arrangement was chosen over a dual fan because of the following advantages: single pylon masts, elimination of deck torsion when stays are stressed, reduced erection time by minimizing stay number, and reduced labor and materials to protect them. The final consideration in choosing a single fan arrangement was aesthetics: it would provide an unobstructed view from the roadways and produce a more attractive structure.

At the time, the cable-stayed technology had been used extensively primarily in Europe. The United States was just beginning to see some application, thus it was considered a fairly new technology by Figg and Muller Engineers and Paschen Contractors.³³ There was a need to verify the design assumptions and the method of construction. There were also the usual concerns regarding the quality and properties of concrete, for both present and future analysis. These issues, coupled with the facts that (i) this bridge would have the longest concrete main span and (ii) replaced a bridge whose failure took the lives of 35 people, created some discomfort and created a desire to monitor the bridge above and beyond the methods of traditional inspection and maintenance procedures. This led to the development of a comprehensive instrumentation plan for the bridge.³⁴

³² "Skyway Bridge Boasts a Record and Innovations." ENR, September 11, 1986, pg. 20-23. See bibliography.

³³ Shahawy, Mohsen. "Comparison of the Analytical and Measured Time-Dependent Strains in the Pylons of the Sunshine Skyway Bridge." Research Report SRR 2-92, Florida Department of Transportation, January 1992

³⁴ Jerry Potter, Florida Department of Transportation. private communication, August, 1995

The instrumentation implemented on the bridge was developed by Construction Technology Laboratories (CTL),³⁵ and included a number of monitoring mechanisms supported by a data acquisition system. The researchers for the firm hoped the data would better define the loading the bridge experiences and the effects of those loads. Additionally, the data was expected to ensure the quality of the fabrication techniques, and provide baseline information to help analyze the assumptions of long span concrete bridge design.³⁶ The instrumentation system also aids in maintenance by indicating the potential for problems before they are visible to inspectors. The cost savings expected between pure inspection versus instrumentation assisted inspections would be enormous.³⁷ In fact, this program proved particularly useful when cracks were noted in the concrete piers during construction. To ensure that the load bearing capacity was not altered by these cracks, a commission was put together to evaluate the structure. It was determined that there would be no adverse effect, but it was suggested that the piers be instrumented.

The following sections present the bridge properties and the instrumentation, and how they were used to determine whether the analytical models corresponded with the actual measured values. Once this correspondence has been determined, it can be determined whether long term predictions are accurate or inaccurate.

4.2. SUPERSTRUCTURE

The Sunshine Skyway Bridge is a precast, segmentally erected, concrete bridge spanning Tampa Bay. It carries two lanes of both north bound and south bound traffic on an 80 ft. wide deck from St. Petersburg to Brandon (see Figure 4-1³⁸) over a major

³⁵ Shahawy, Mohsen. "Comparison of the Analytical and Measured Time-Dependent Strains in the Pylons of the Sunshine Skyway Bridge." Research Report SRR 2-92, Florida Department of Transportation, January 1992

³⁶ "Bridge Builder's Primary Concern is With Safety." *Engineering News-Record*, v. 215, Aug. 8, 1985, pg. 30-1

³⁷ Di Vietro, Philip. "Monitoring a Bridge's Pulse." *Civil Engineering*, v. 56, March 1986, pg. 54-55

³⁸ Shawawy, Mohsen. "Field Instrumentation to Study the Time Dependent Behavior in the Sunshine Skyway Bridge." Research Report No. SRR 01-92, Florida Department of Transportation, January 1992.

shipping channel. This bridge consists of four types of spans: trestle approach spans, low level approach spans, high level approach spans, and cable stayed spans, which easily satisfy any navigational clearance requirements. The trestle approach spans are composed of prestressed I-girders and account for 13,018 feet (3968 m). Low level approach spans use twin box girders and make up a 4860 feet (1481 m) of the Skyway bridge. The high level approach spans are made of a single cell box girder, with span lengths of 140 to 240 feet (42.7 to 73.1 m) to equal 1720 feet (524 m) of the bridge (refer to Figure 4-2³⁹). The cable stayed spans are a total of 2280 feet (695 m) long, and are the focus of this chapter. The high level approaches and cable stayed spans are a total of 4000 ft. (1219 m), and are continuously post-tensioned- creating a 4000 ft. section with no expansion joints.

The 2280 foot long stayed section has a 1200 foot (366 m) long center span and two 540 foot (165 m) long side spans (Figure 4-2). The bridge provides for a vertical navigational clearance of 175 ft. (53.3 m) above sea level. There are 21 cable stays on each side of the pylons, arranged in a single plane, fan arrangement. The stays are composed of varying numbers of no. 7 wire prestressing strands, grade 270 ASTM A-416 stress relieved. They are encased in steel pipes up to 8.625 inches in diameter with ASTM A 53, grade B steel. They are continuous through the pylons, rest on steel saddles, and are anchored in the median of the cable stayed portion of the main continuous span superstructure at 24 ft. (7.31 m) intervals (see Figure 4-3⁴⁰). Each stay has a trumpet resting underneath the top ceiling of the segments. These trumpets are designed to attach jacks against the bottom of the top deck and return the tension to the original state.

The pylons are formed by cast- in place, reinforced concrete sections. The profile of the center span pylons, PIN, are shown in Figure 4-4⁴¹. They reach a height 242 ft. (73.8 m) above the deck. The pylon, girder, and piers are rigidly connected at the base of the

³⁹ Sunshine Skyway Bridge, Drawings and Specifications, by Figg and Muller Engineers Inc. 1982, pg 3; This is a public document- per communication on February 1, 1996 at 10:00 am.

⁴⁰ Sunshine Skyway Bridge, Drawings and Specifications, by Figg and Muller Engineers Inc. 1982, pg. 27 and 30; This is a public document- per communication on February 1, 1996 at 10:00 am.

⁴¹ Sunshine Skyway Bridge, Drawings and Specifications, by Figg and Muller Engineers Inc. 1982, pg. 12; This is a public document- per communication on February 1, 1996 at 10:00 am.

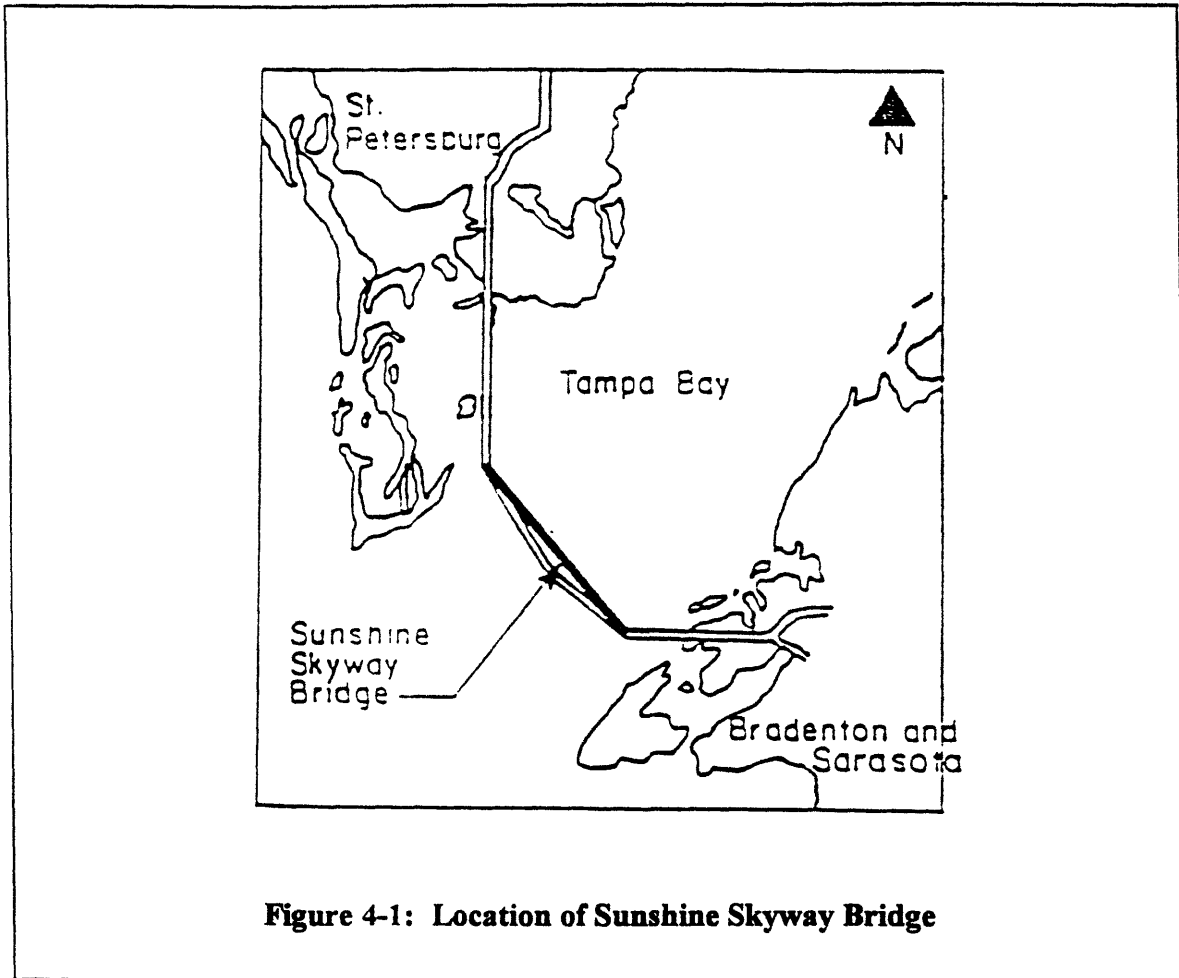

Figure 4-1: Location of Sunshine Skyway Bridge

pylons. Longitudinal movement is allowed for by the flexibility of the pier shafts. There are also piers at five other locations in the side spans, creating the three side spans composing the high level approaches of 240 ft. each and one at 140 ft. on each side of the cable-stayed span (refer to Figure 4-2). A pier profile is shown in Figure 4-5.⁴²

⁴² Sunshine Skyway Bridge, Drawings and Specifications, by Figg and Muller Engineers Inc. 1982, pg. 7/369; This is a public document- per communication on February 1, 1996 at 10:00 am.

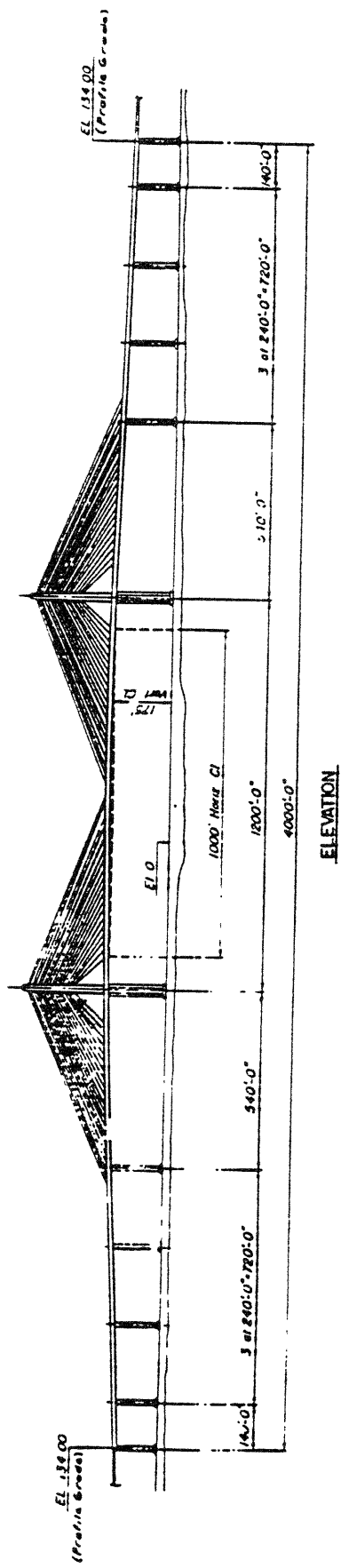
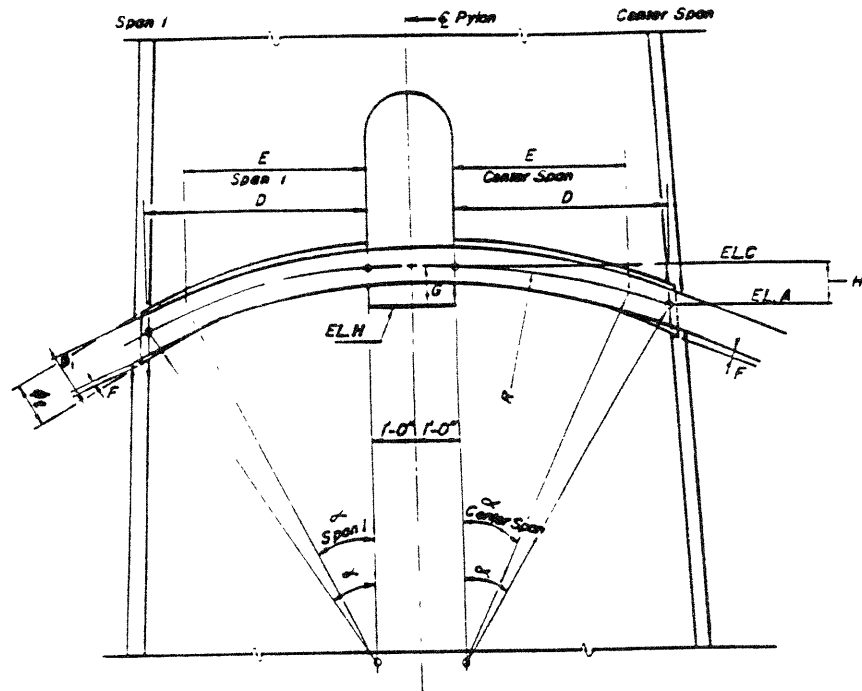

Figure 4-2: Elevation of Sunshine Skyway Bridge

The main cable-stayed span is monolithic unit composed of 96 individual precast, prestressed concrete box girder segments. There is transverse post-tensioning in the top and bottom flanges and in the web. Each segment (Figure 4-6) is 14 ft. 8 in. deep, 94 ft. 5 in. wide, and 12 ft. long (4.47 m x 28.8 m x 3.66 m). The existence of cable stay anchorages creates a slight variation in the segments to accommodate the stay anchorages and forces (details in Figure 4-6)⁴³. Each segment was cast in one day, with the largest such segment weighing 170 tons. They are match cast at the webs and bottom flange, with the top flange blocked back to permit a 1 ft. cast in place joint after erection. The cantilever method of construction was employed for the main span and those spans adjacent to them.

The material properties of the piers, segments, and pylons are presented in Table 4-1. The type of concrete, reinforcing steel, and the prestressing strands are given generally for the substructure and superstructure.

⁴³ Sunshine Skyway Bridge, Drawings and Specifications, by Figg and Muller Engineers Inc. 1982, pg. 18



DEVIATION SADDLE

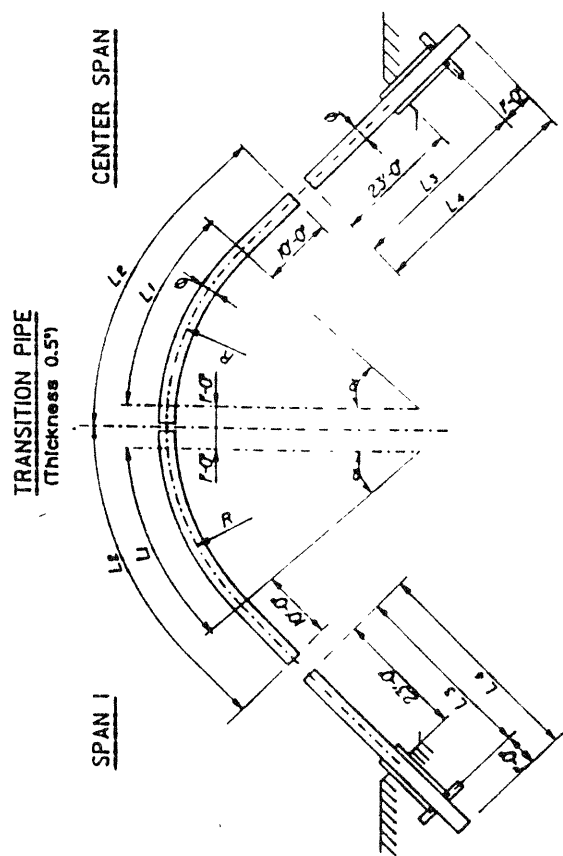

R	SPAN I				CENTER SPAN				β	R	CENTER SPAN				β	R														
	α°	L1	L2	L3	L4	α°	L1	L2			L3	L4																		
1	12.5	6.625	20.095	25.292	26.292	10.5	6.625	48.371	8.865	19.865	25.129	26.129	26.597	26.597	10.5	6.625	20.095	25.292	26.292	26.292	10.5	6.625	48.371	8.865	19.865	25.129	26.129	26.597	26.597	
2	11.5	4.470	8.972	19.972	25.763	11.5	4.470	43.095	8.650	19.650	25.597	26.597	27.024	27.024	11.5	4.470	8.972	19.972	25.763	26.292	26.292	11.5	4.470	43.095	8.650	19.650	25.597	26.597	26.597	
3	12.0	4.002	8.597	19.597	26.192	12.0	4.002	39.143	8.198	19.198	26.024	27.024	27.451	27.451	12.0	4.002	8.597	19.597	26.192	26.719	26.719	12.0	4.002	39.143	8.198	19.198	26.024	27.024	27.451	27.451
39	4	38.860	8.325	19.325	26.585	12.5	36.114	7.879	18.879	26.417	27.417	27.844	27.844	12.5	36.114	7.879	18.879	26.585	27.146	27.146	12.5	36.114	7.879	18.879	26.417	27.417	27.844	27.844		
38	5	35.989	8.150	19.150	26.946	13.0	33.722	7.651	18.651	26.775	27.775	28.202	28.202	13.0	33.722	7.651	18.651	26.946	27.474	27.474	13.0	33.722	7.651	18.651	26.775	27.775	28.202	28.202		
37	6	34.026	7.943	18.943	27.280	13.5	31.807	7.279	18.279	27.088	28.088	28.515	28.515	13.5	31.807	7.279	18.279	27.280	27.979	27.979	13.5	31.807	7.279	18.279	27.088	28.088	28.515	28.515		
36	7	32.650	7.693	18.693	27.587	14.0	30.249	7.227	18.227	27.443	28.443	28.870	28.870	14.0	30.249	7.227	18.227	27.587	28.186	28.186	14.0	30.249	7.227	18.227	27.443	28.443	28.870	28.870		
35	8	31.537	7.431	18.431	27.850	14.5	29.000	6.933	17.933	27.748	28.748	29.175	29.175	14.5	29.000	6.933	17.933	27.850	28.489	28.489	14.5	29.000	6.933	17.933	27.748	28.748	29.175	29.175		
34	9	30.528	7.168	18.168	28.114	15.0	27.960	6.378	17.378	28.053	29.053	29.480	29.480	15.0	27.960	6.378	17.378	28.114	28.794	28.794	15.0	27.960	6.378	17.378	28.053	29.053	29.480	29.480		
33	10	29.625	6.900	17.900	28.378	15.5	27.068	6.378	17.378	28.358	29.358	29.785	29.785	15.5	27.068	6.378	17.378	28.378	29.118	29.118	15.5	27.068	6.378	17.378	28.358	29.358	29.785	29.785		
32	11	28.868	6.601	17.601	28.642	16.0	26.282	6.378	17.378	28.663	29.663	30.090	30.090	16.0	26.282	6.378	17.378	28.642	29.373	29.373	16.0	26.282	6.378	17.378	28.663	29.663	30.090	30.090		
31	12	28.200	6.345	17.345	28.906	16.5	25.600	6.032	17.032	28.978	29.978	30.400	30.400	16.5	25.600	6.032	17.032	28.906	29.678	29.678	16.5	25.600	6.032	17.032	28.978	29.978	30.400	30.400		
30	13	27.636	6.072	17.072	29.170	17.0	24.976	5.885	16.885	29.288	30.288	30.700	30.700	17.0	24.976	5.885	16.885	29.170	29.988	29.988	17.0	24.976	5.885	16.885	29.288	30.288	30.700	30.700		
29	14	27.156	5.799	16.799	29.434	17.5	24.400	5.773	16.773	29.598	30.598	31.000	31.000	17.5	24.400	5.773	16.773	29.434	30.298	30.298	17.5	24.400	5.773	16.773	29.598	30.598	31.000	31.000		
28	15	26.682	5.526	16.526	29.698	18.0	23.874	5.666	16.666	29.908	30.908	31.300	31.300	18.0	23.874	5.666	16.666	29.698	30.608	30.608	18.0	23.874	5.666	16.666	29.908	30.908	31.300	31.300		
27	16	26.298	5.253	16.253	29.962	18.5	23.398	5.572	16.572	30.218	31.218	31.600	31.600	18.5	23.398	5.572	16.572	29.962	30.908	30.908	18.5	23.398	5.572	16.572	30.218	31.218	31.600	31.600		
26	17	25.922	4.980	15.980	30.226	19.0	22.970	5.494	16.494	30.528	31.528	31.900	31.900	19.0	22.970	5.494	16.494	30.226	31.208	31.208	19.0	22.970	5.494	16.494	30.528	31.528	31.900	31.900		
25	18	25.554	4.707	15.707	30.484	19.5	22.594	5.401	16.401	30.838	31.838	32.200	32.200	19.5	22.594	5.401	16.401	30.484	31.508	31.508	19.5	22.594	5.401	16.401	30.838	31.838	32.200	32.200		
24	19	25.206	4.434	15.434	30.742	20.0	22.270	5.334	16.334	31.148	32.148	32.500	32.500	20.0	22.270	5.334	16.334	30.742	31.808	31.808	20.0	22.270	5.334	16.334	31.148	32.148	32.500	32.500		
23	20	24.888	4.161	15.161	31.000	20.5	21.996	5.292	16.292	31.458	32.458	32.800	32.800	20.5	21.996	5.292	16.292	31.000	32.108	32.108	20.5	21.996	5.292	16.292	31.458	32.458	32.800	32.800		
22	21	24.590	3.888	14.888	31.258	21.0	21.722	5.249	16.249	31.768	32.768	33.100	33.100	21.0	21.722	5.249	16.249	31.258	32.408	32.408	21.0	21.722	5.249	16.249	31.768	32.768	33.100	33.100		
21	22	24.315	3.615	14.615	31.516	21.5	21.448	5.206	16.206	32.078	33.078	33.400	33.400	21.5	21.448	5.206	16.206	31.516	32.708	32.708	21.5	21.448	5.206	16.206	32.078	33.078	33.400	33.400		

ESTIMATED QUANTITIES		
8.625' of pipe (0.5')	1.000'	2.660'
8.625' of pipe (0.5')	1.000'	2.660'

Figure 4-3: Cable Stay Details.

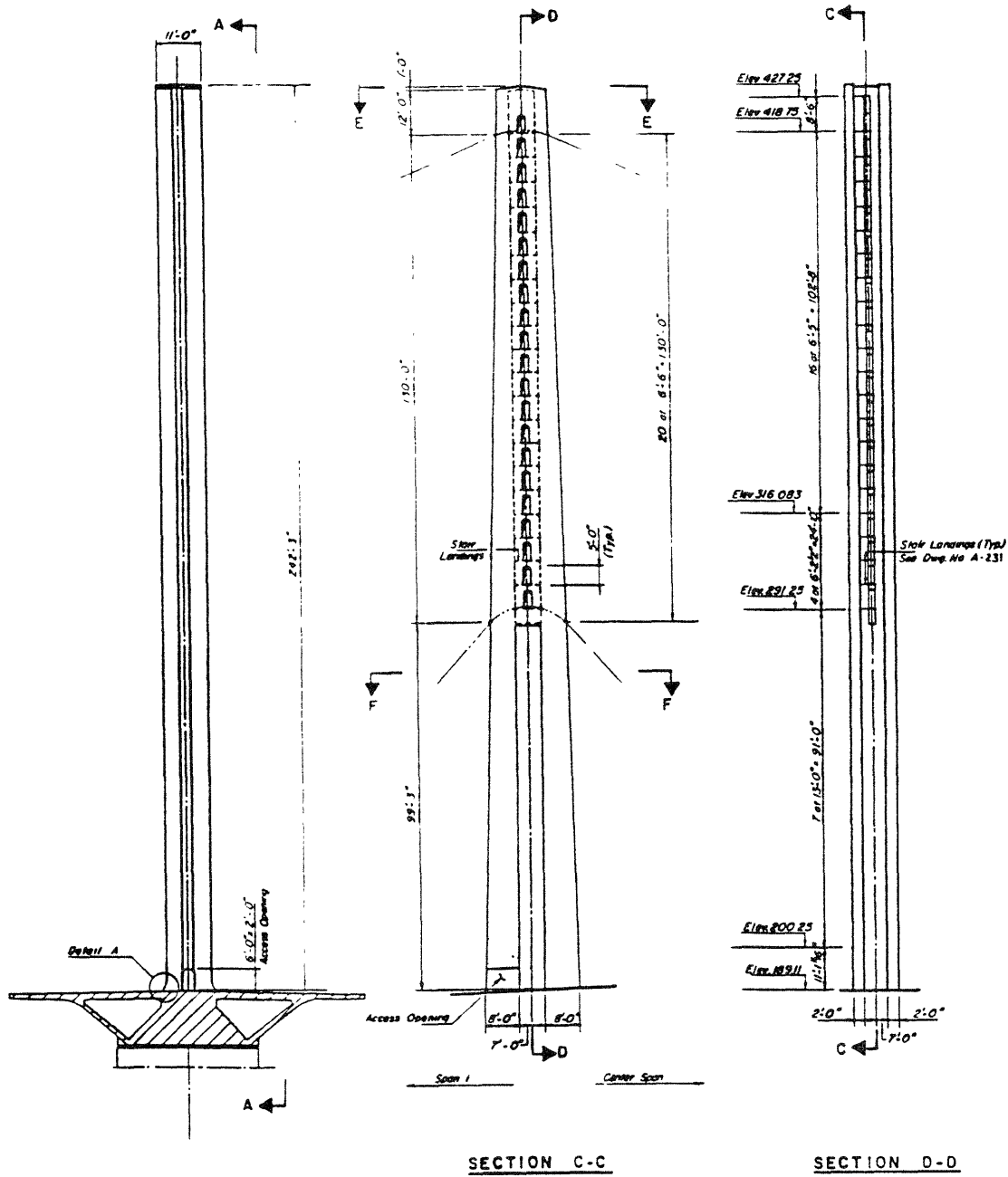

Figure 4-4: Pylon Profile and Section for Center Span

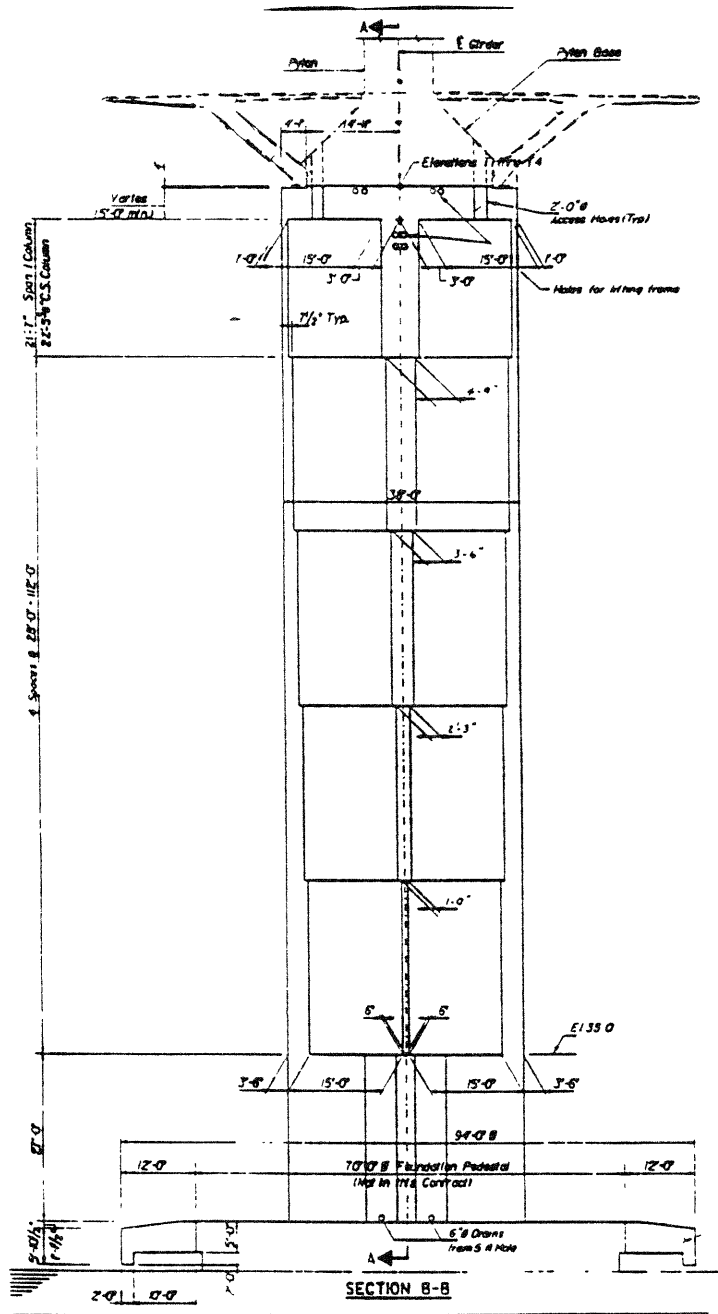

Figure 4-5: Typical Pier Concrete Outline- Profile View

Table 4-1: Material Properties of the Sunshine Skyway Bridge⁴⁴

CONCRETE: Class IV (28 Day Cylinder Strengths Noted)

Precast Superstructure (include clip joints)	5500 psi
Pier Table at 1N1S	5500 psi
Pier 1N1S Shafts	5500 psi
Precast and Cip Box Piers	5500 psi
Footings (Piers 2-6)	4200 psi
Footings (Piers 7-24)	3400 psi
Precast Footing Form (Piers 2-5)	3400 psi
Precast Footing Form And Strut (Piers 6-24)	5500 psi
Drilled Shafts	3400 psi
Precast Square\Octagonal Piling	5000 psi
Precast Cylinder Piling (Centrifugally Spun)	7000 psi
Pylon	8000 psi

REINFORCING STEEL: ASTM A 615, Grade 60 unless otherwise noted. All steel shall be epoxy coated. Concrete covers shall be:

- Superstructure: 2" external, 1 3/4" internal
- Substructure (CIP): 4"
- Substructure (precast): 3"
- Precast, Pretensioned Piling: 3" (External)
- Drilled Shafts: (4" inside casing)

POST-TENSIONING STEEL:

- Strand: ASTM A 416, Grade 270, Low Relaxation
- Bars: ASTM A 722, Grade 150 (Type II)
- Prestressing Parameters (strand):
- Friction Coefficient: 0.23
- Wobble Coefficient: 0.0 (External)
0.0015 (Internal)
- Anchor Set: 0.375"
- Apparent Modulus(for calculation of equation): 28, 500 ksi
- Maximum Jacking Stress: 216 ksi (80% ultimate)
- Maximum Anchoring Stress: 189 ksi (70% ultimate)

⁴⁴ Sunshine Skyway Bridge, Drawings and Specifications, by Figg and Muller Engineers Inc. 1982, pg. 5/369; This is a public document- per communication on February 1, 1996 at 10:00 am.

4.3. STRUCTURAL CONCERNS

The behavior of any structure is a function of its material properties and design. The Sunshine Skyway Bridge (Skyway) had several significant issues affecting behavior, such as prestress tension, balanced cantilever segmental construction method, and the cable stay design. The Skyway contains 180,000 cubic yards of concrete, 20 million pounds of steel, 5,347,100 feet of post-tensioning cable, and 2,359,115 feet of cable-stay strands.⁴⁵ The prediction of behavior becomes quite difficult because of the uncertainty of each of these variables. Accurate estimation of time dependent prestress losses is particularly important in this structure because it is a prestressed concrete structure. Errors in computing prestress losses would not affect the ultimate strength of the flexural member, but could adversely affect the serviceability of the structural member. This would include camber, deflection, and crack control. The massive presence of the high strength concrete used in the structure also garners the usual concerns of quality control and thermal cracking. In fact, this proved to be a significant issue in this structure.⁴⁶

Construction of the Skyway commenced in 1982. In 1983, after the first piers were poured, cracks were discovered. This enhanced the controversy over the bridge. There was already significant public concern surrounding the bridge.⁴⁷ The destruction of the previous bridge by ship impact (see section 4.1) and the failure of numerous bridges in the area already created some discomfort with the structure. Furthermore, a study performed by the National Transportation Research Board showed nationwide standards for protecting bridges from collisions were lacking, and there were no American Association of State Highway and Transportation Officials (AASHTO) recommendations for pier

⁴⁵ Waggoner, Holly. Skyway to the Sun. Omnigrafi Publishers, c. 1988, pg. 43

⁴⁶ "Niggling Problems Plague Sunshine Skyway Bridge Job." *Engineering News-Record*, v. 211, March 15, 1984, pg. 13

⁴⁷ "Bridge Builder's Primary Concern is With Safety." *Engineering News-Record*, v. 215, Aug. 8, 1985, pg. 30-1

protection.⁴⁸ Thus, the engineers of the Skyway did not have any guidelines for the new bridge. The potential challenge to the structural integrity of the bridge and the load bearing capacity of the piers presented to the Florida Department of Transportation (FDOT) an issue that needed to be addressed quickly. Several panels were developed to examine the cracks and accordingly several reports were produced. FDOT determined that the cracks were not a threat to the structural integrity and load bearing capacity of the piers; rather they were just typical of concrete.⁴⁹ Another report stated that the Florida limestone used as aggregate in the concrete was inferior, that its permeability, absorptivity, and deformability were characteristics that lead to concrete crumbling and reinforcement corrosion.⁵⁰ All of these reports were challenged, and in the end it was determined that the cracks should not pose a threat and were simply a function of shrinkage due to temperature difference between the concrete curing and the water temperature.⁵¹ To be certain, though, Construction Technology Laboratories was assigned the task of developing and maintaining a continuous monitoring program for the structure. This system was to provide information on temperature, movements, stresses, and strain during and after construction. It would also be able to assist in maintenance by locating potential problems before they were visible to inspectors, but was not intended to replace the traditional inspection and maintenance program. The following sections describe elements of the instrumentation, the inspection and maintenance program, and analysis and results.

4.4. FIELD INSTRUMENTATION

The instrumentation program on the Sunshine Skyway was the first such program to be implemented on a large scale. As discussed in the previous chapter, instrumentation could be used to verify design assumptions and assist in the maintenance of the structure. The

⁴⁸ "Bridge Builder's Primary Concern is With Safety." *Engineering News-Record*, v. 215, Aug. 8, 1985, pg. 30-1

⁴⁹ "Skyway pier cracks probed." *Engineering News Record*, v. 211, Nov. 17, 1983, pg 12

⁵⁰ "Engineers Hit Florida DOT for Decisions on Major Jobs." *Engineering News-Record*, v. 213, 2 February 1984

⁵¹ "Skyway pier cracks probed." *Engineering News Record*, v. 211, Nov. 17, 1983, pg 12

Sunshine Skyway was instrumented to verify design assumptions in the concrete and structural behavior. It was specifically intended to supplement time dependent strain analysis. Data was also supplied on shrinkage and creep, which through analysis, provided fairly accurate measurements of Poisson's ratio, concrete compressive strength, modulus of elasticity, coefficient of thermal expansion, concrete strains, and temperature distributions. The instrumentation was functional during construction and for the first three years after construction. Thus, at the current time, the instruments are not being used.

The Sunshine Skyway Bridge is assumed to be symmetric about the center in both design and behavior, therefore the bridge was instrumented on only half the cable-stayed section of the bridge. This would include segments around pylon P1N and piers P2N and P3N, but not going beyond pier P4N (these piers and their designation are shown in Figure 4-7⁵²). The instrumentation exists on 17 precast bridge segments, 3 pylon sections, and 11 sections of two main piers. Figure 4-8, Figure 4-9, and Figure 4-10⁵³ together describe the locations of the segments listed in Table 4-2⁵⁴, which lists the instrumented sections and the type and number of instruments on them. Each figure respectively shows the locations near the piers P3N, P2N and P1N, and P1S. 228 concrete strain gauges and 306 temperature sensors are used to simultaneously gather real-time information on the bridge. Monitoring bridge behavior included measurements of longitudinal concrete strains, concrete temperatures, and vertical pylon deflections. Initial data was taken manually, until a data acquisition system was implemented. In the following sections, the types and locations of the instrumentation are presented, followed by a description of the data acquisition system.

⁵² Shawawy, Mohsen. "Comparison of the Analytical and Measured Time Dependent Strains in the Segments of the Sunshine Skyway Bridge." Research Report No. SRR 03-92, Florida Department of Transportation, January 1992.

⁵³ Shawawy, Mohsen. "Field Instrumentation to Study the Time Dependent Behavior in the Sunshine Skyway Bridge." Research Report No. SRR 01-92, Florida Department of Transportation, January 1992

⁵⁴ Shawawy, Mohsen. "Field Instrumentation to Study the Time Dependent Behavior in the Sunshine Skyway Bridge." Research Report No. SRR 01-92, Florida Department of Transportation, January 1992

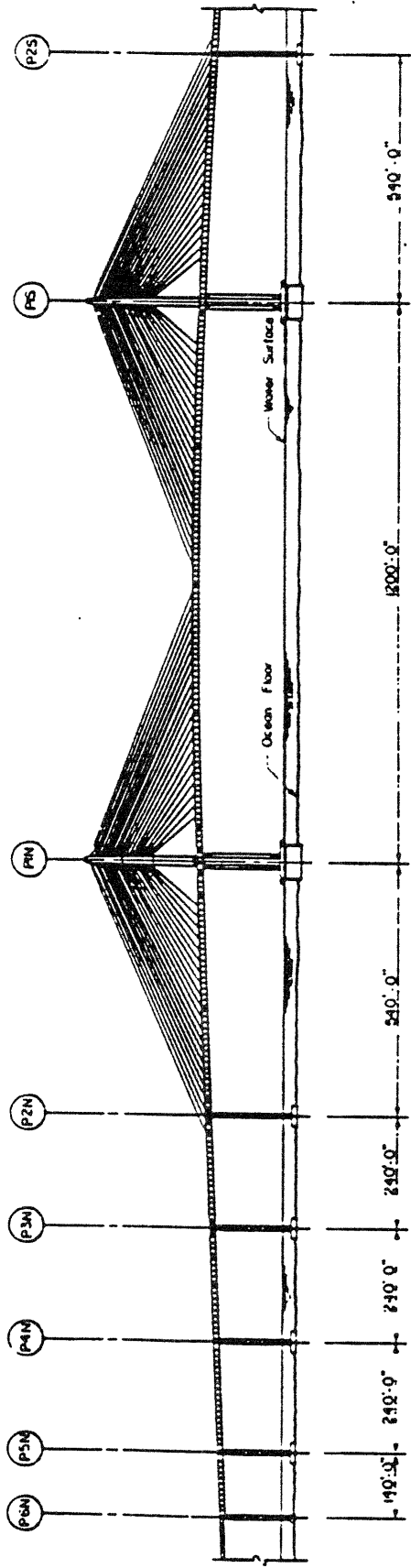
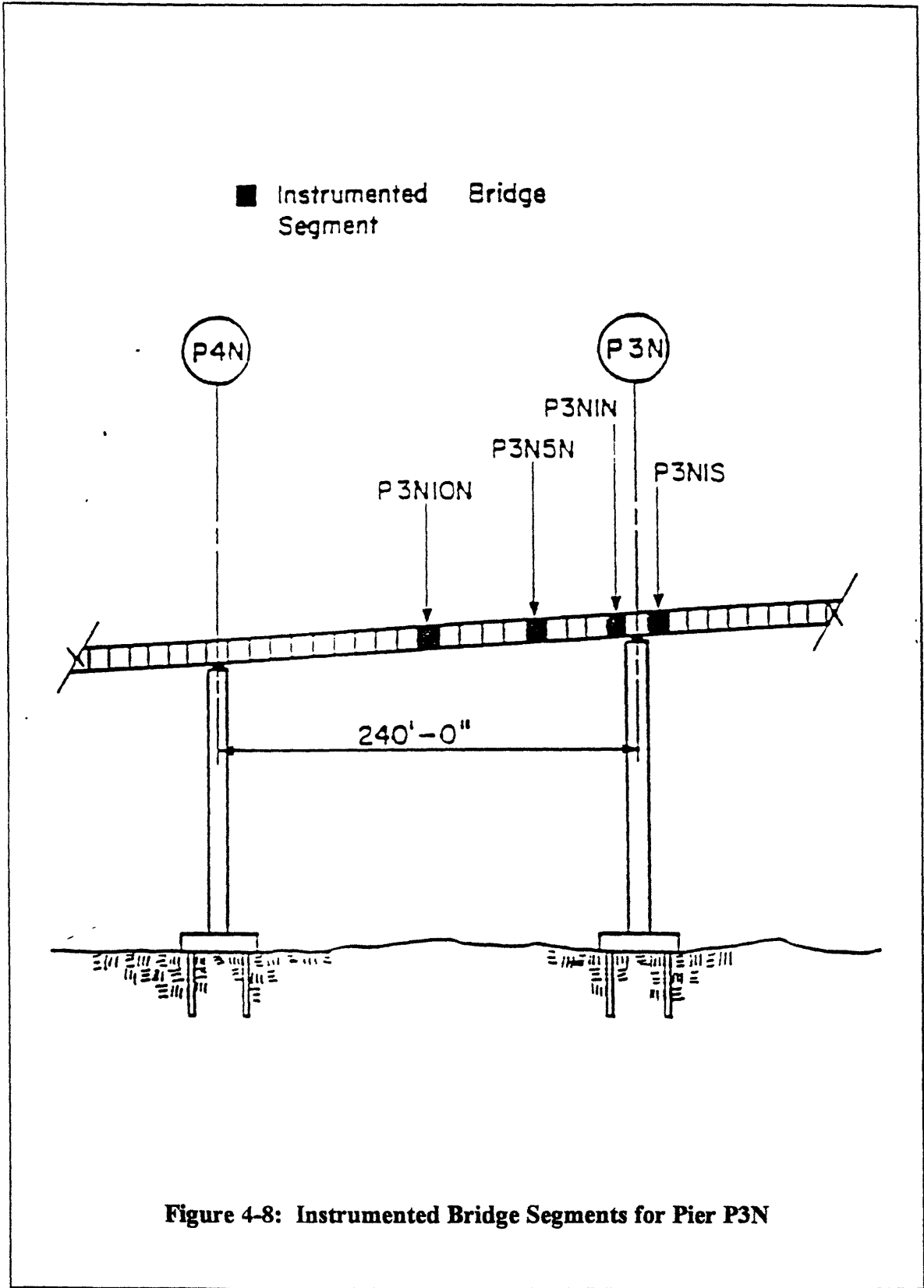

Figure 4-7: Pier Designations



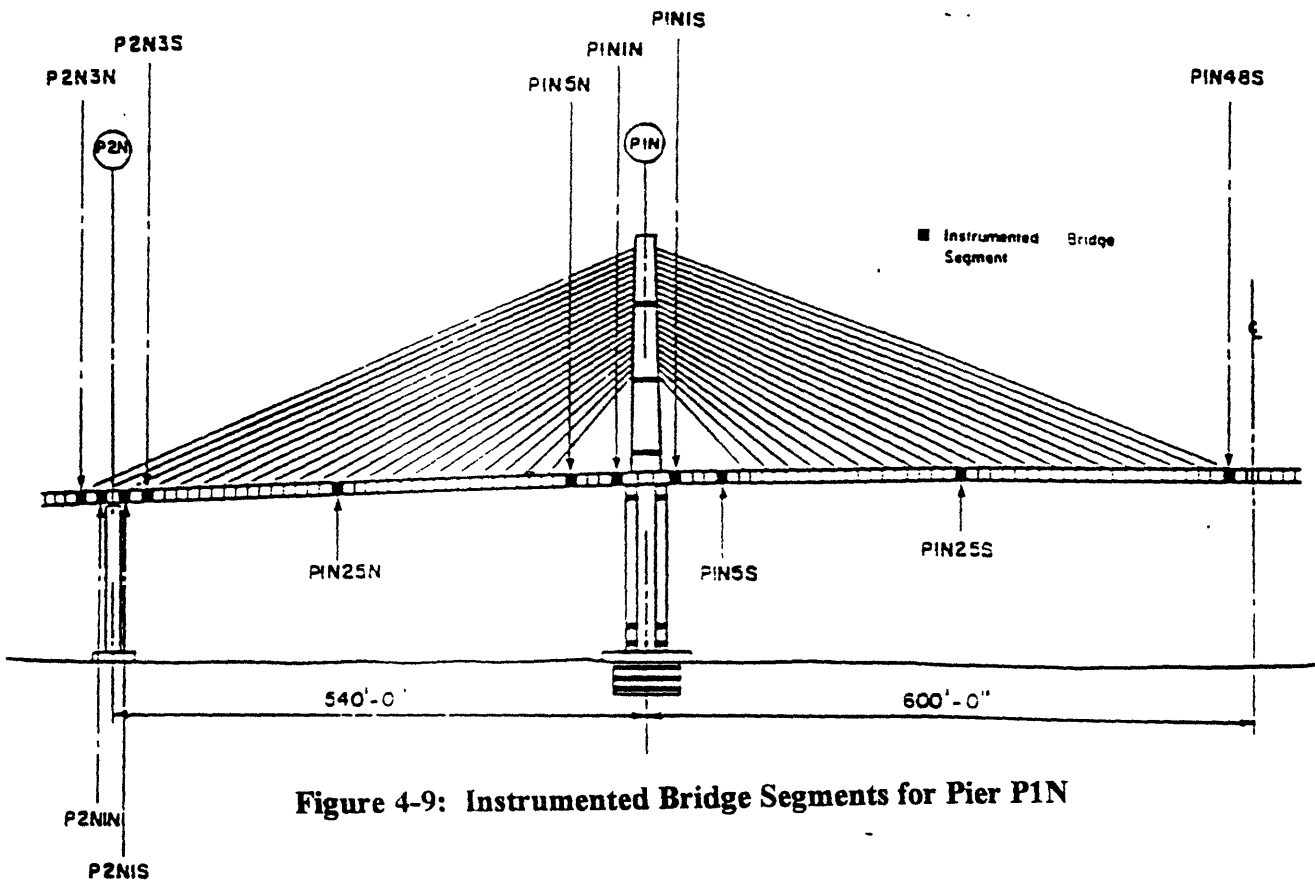

Figure 4-9: Instrumented Bridge Segments for Pier P1N

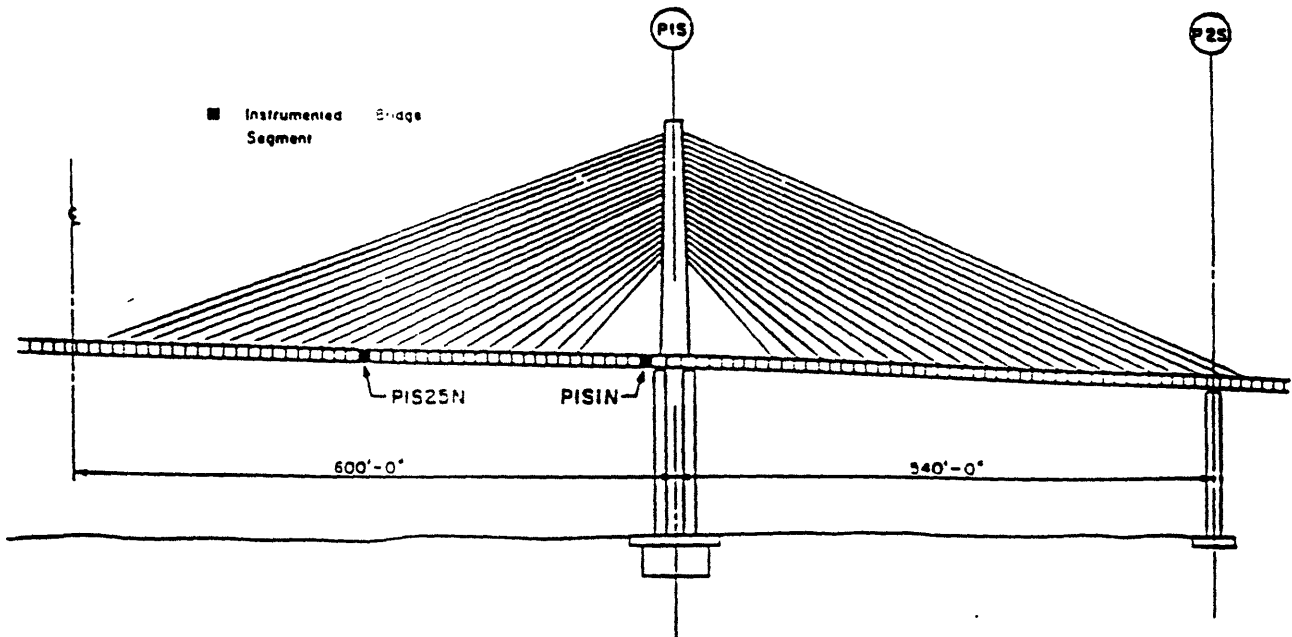

Figure 4-10: Instrumented Bridge Segments for Pier 1S

Table 4-2: Summary of Instrumentation on Sunshine Skyway Bridge

INSTRUMENTED SECTION	NUMBER OF CARLSON STRAIN METERS	NUMBER OF THERMOCOUPLES
SEGMENT SECTIONS		
P3N1N	11	28
P3N5N	11	--
P3N10N	11	28
P3N1S	11	--
P2N1N	11	--
P2N3N	7	--
P2N1S	11	--
P2N3S	7	--
P1N1N	7	--
P1N5N	7	--
P1N25N	7	--
P1N1S	11	28
P1N5S	11	28
P1N25S	11	28
P1N48S	11	28
P1S1N	7	--
P1N25N	7	--
PYLON SECTIONS ABOVE BASE		
8 FT.	7	--
85 FT.	6	14
145 FT.	4	--

4.4.1 TYPES AND LOCATION OF INSTRUMENTS ON BRIDGE

INSTRUMENTS

There were two types of instruments used on the Sunshine Skyway Bridge: strain gages and thermocouples. The specific types of thermocouples were not available. The strain meters, however, were Carlson strain meters of type A-10 with 4-wire conductor cable with a gage length of 10 inches.⁵⁵ The two readings provided by each Carlson strain meter

⁵⁵ Shawawy, Mohsen. "Field Instrumentation to Study the Time Dependent Behavior in the Sunshine Skyway Bridge." Research Report No. SRR 01-92, Florida Department of Transportation, January 1992. pg. 18

represent concrete strain and temperature at the location of the strain meter. A total of 232 Carlson strain meters were used with 159 strain meters for the 17 bridge segments, 17 strain meters for the three pylon sections, and 56 strain meters for the 11 pier sections.

SEGMENTS

The Carlson strain meters were embedded in the concrete segments prior to casting. In order to measure longitudinal deformations along the main bridge axis, strain meters were installed horizontally. The detailed locations of the installed Carlson strain meters in a typical bridge segment are shown in Figure 4-11. Manual readings were taken initially and later the automatic data acquisition system (ADAS) was installed to record the measurement at regular time intervals, during and for three years after construction.

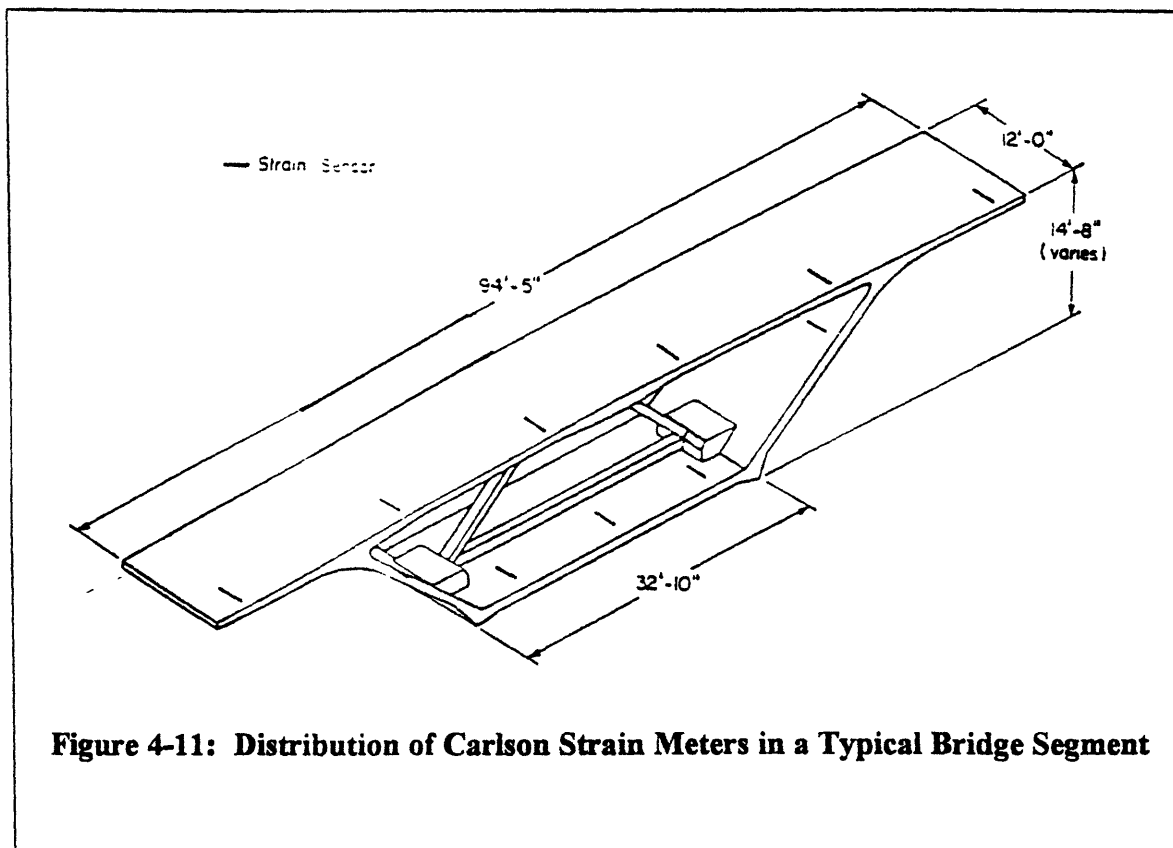

Figure 4-12: Measured Strain History of Segment P1N1S During Erection Sequence; Segment is Under Dead Load

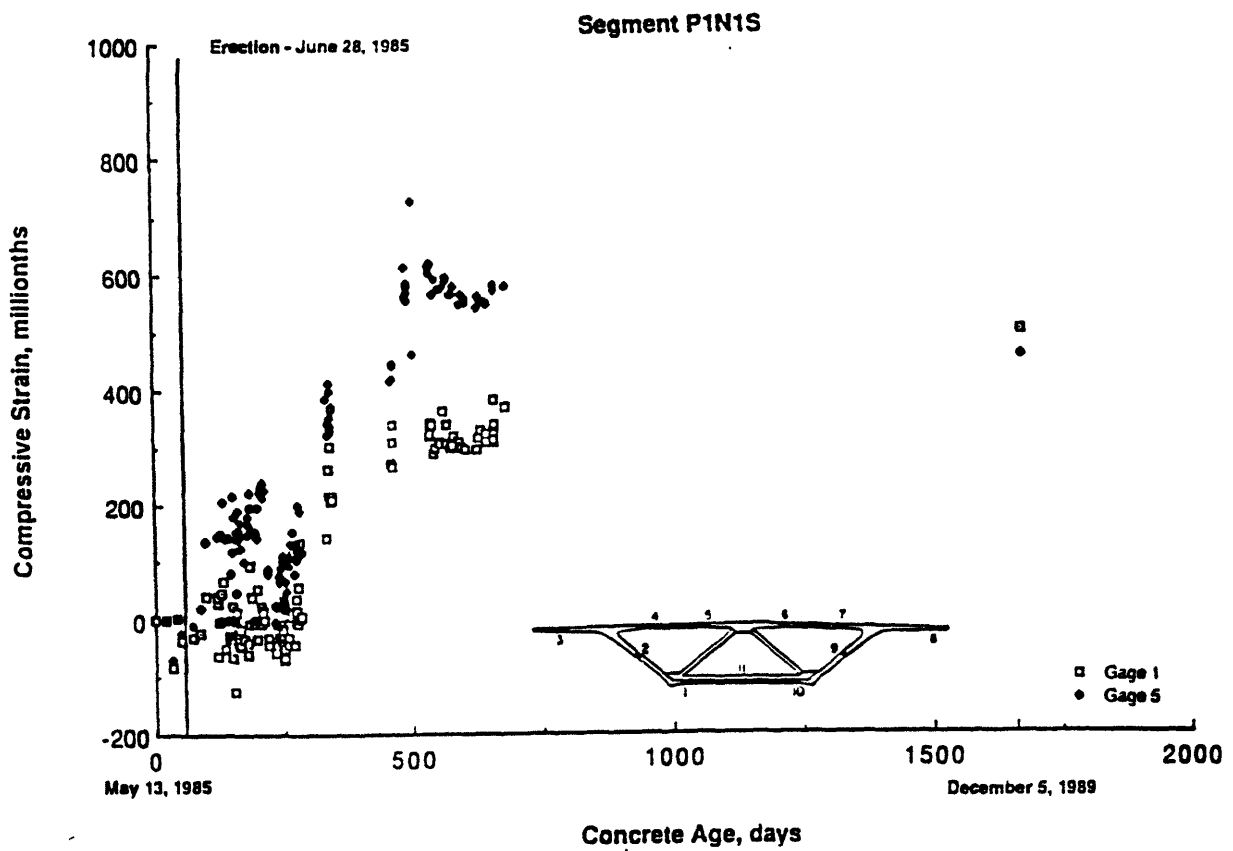

Figure 4-13: Measured Strain History of Segment P1N1N During Erection
Sequence: Segment is Under Dead Load.

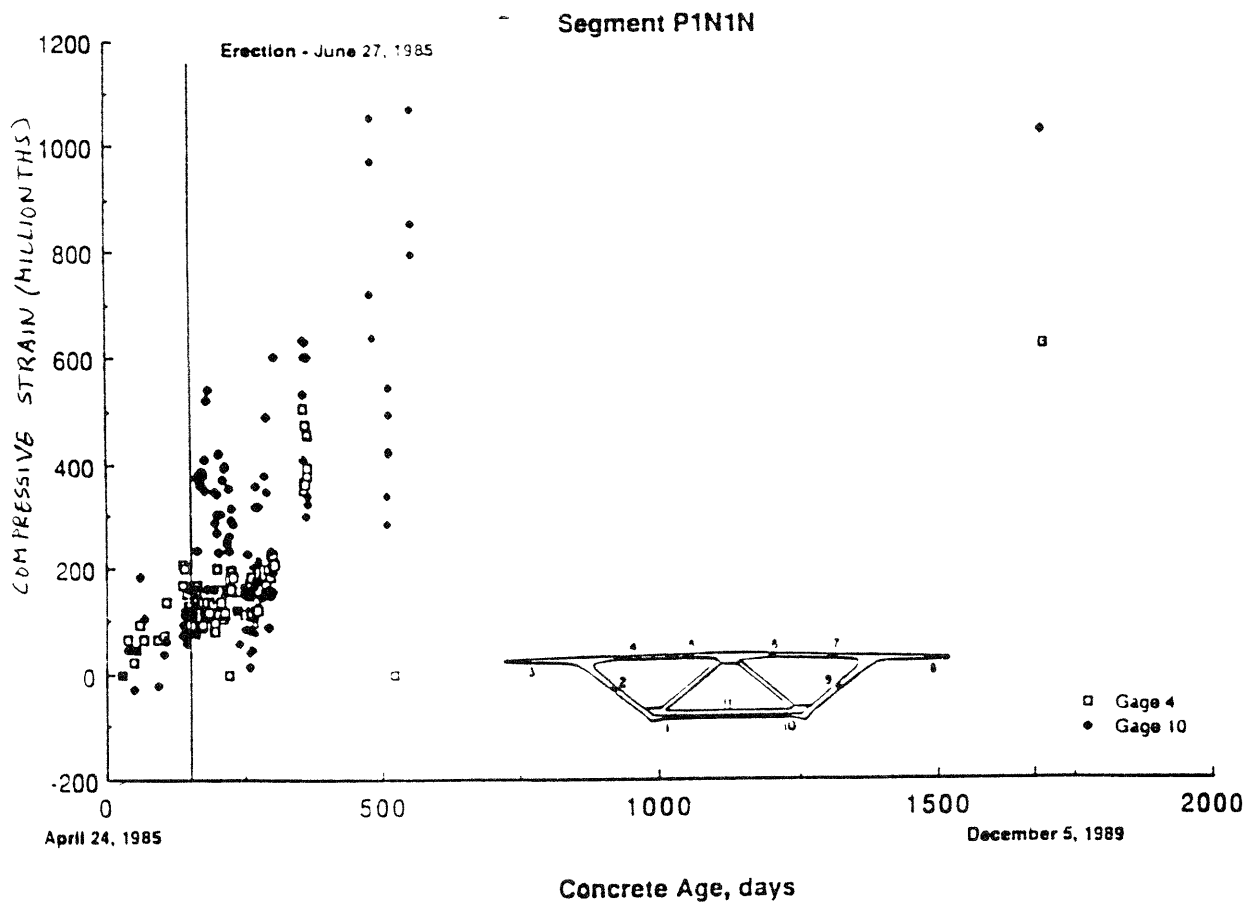
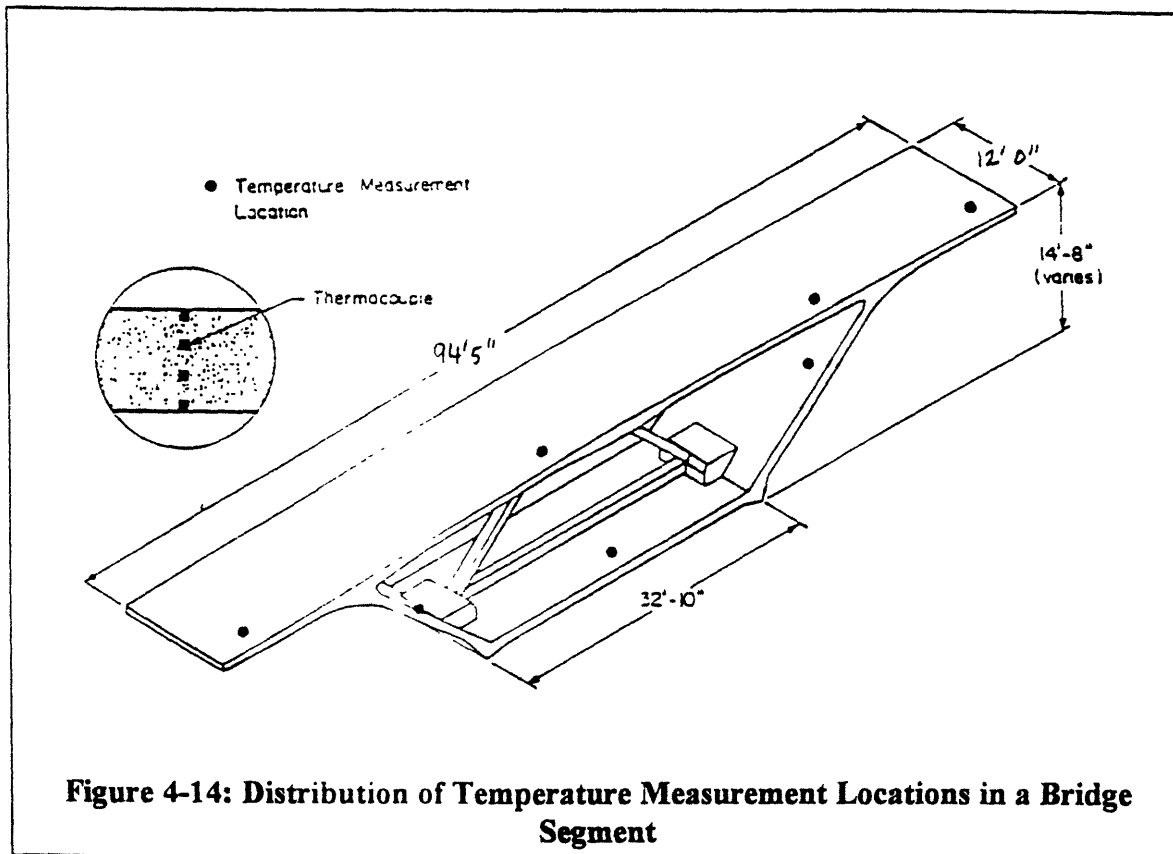

Figure 4-11⁵⁶ shows the locations of the strain meters in the segments P1N1N and P1N1S and Figure 4-12 and Figure 4-13 shows the measured strain histories of the same segments.

Selected bridge segments were instrumented with 28 thermocouples for monitoring temperature effects on the bridge superstructure. Thermocouples were divided into seven groups, each with four thermocouples. The temperature distribution was measured through the depth of the concrete slab of the box section. Figure 4-14 shows the distribution of the seven thermocouple group around a bridge segment. To ensure proper placement across the slabs, thermocouples were embedded in the concrete prior to casting. Extension wires of the thermocouples attached to the underside of the reinforcement cage were bundled up and taken out of the bridge segment concrete at the same location as the Carlson strain lead wires.

⁵⁶ Shahawy, Mohsen. "Comparison of the Analytical and Measured Time-Dependent Strains in the Segments of the Sunshine Skyway Bridge." Research Report SRR 3-92, Florida Department of Transportation, January 1992



PYLON

In the pylon, all the strain meters were positioned vertically to measure variations of vertical concrete movements of the pylon with time. Figure 4-15⁵⁷ shows the general locations of the meters in the three pylon sections. Since the pylons were cast-in-place, the Carlson strain meters were installed at the bridge site in the three pylon sections and the pier section, 8 feet below the roadway. Carlson strain lead wires for the pylon sections were routed through a conduit to the pylon base of pier P1N. The conduit was installed in every section of the pylon up to 145 feet above the pylon base.

⁵⁷ Shahawy, Mohsen. "Comparison of the Analytical and Measured Time-Dependent Strains in the Pylons of the Sunshine Skyway Bridge." Research Report SRR 2-92, Florida Department of Transportation, January 1992

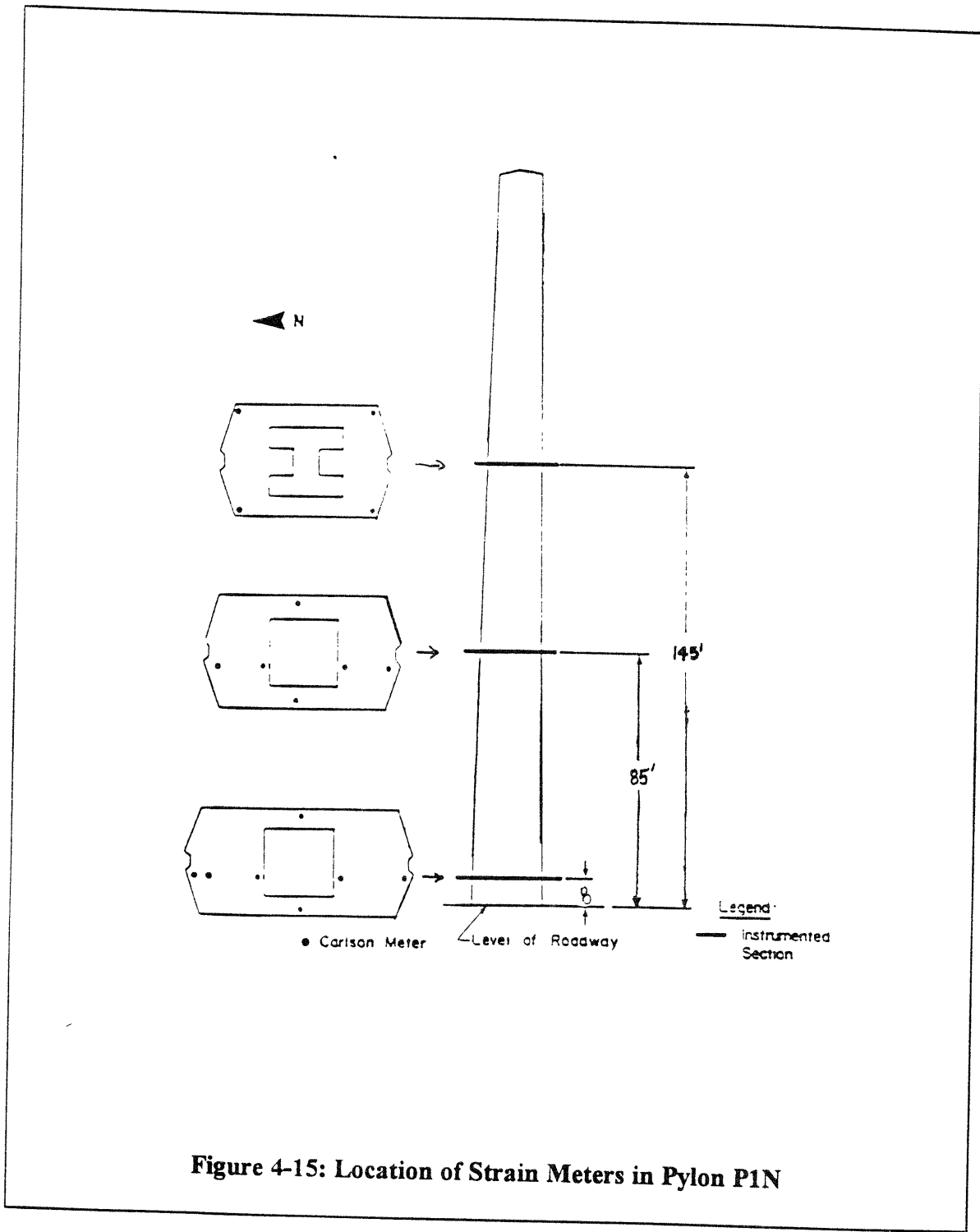

Figure 4-15: Location of Strain Meters in Pylon P1N

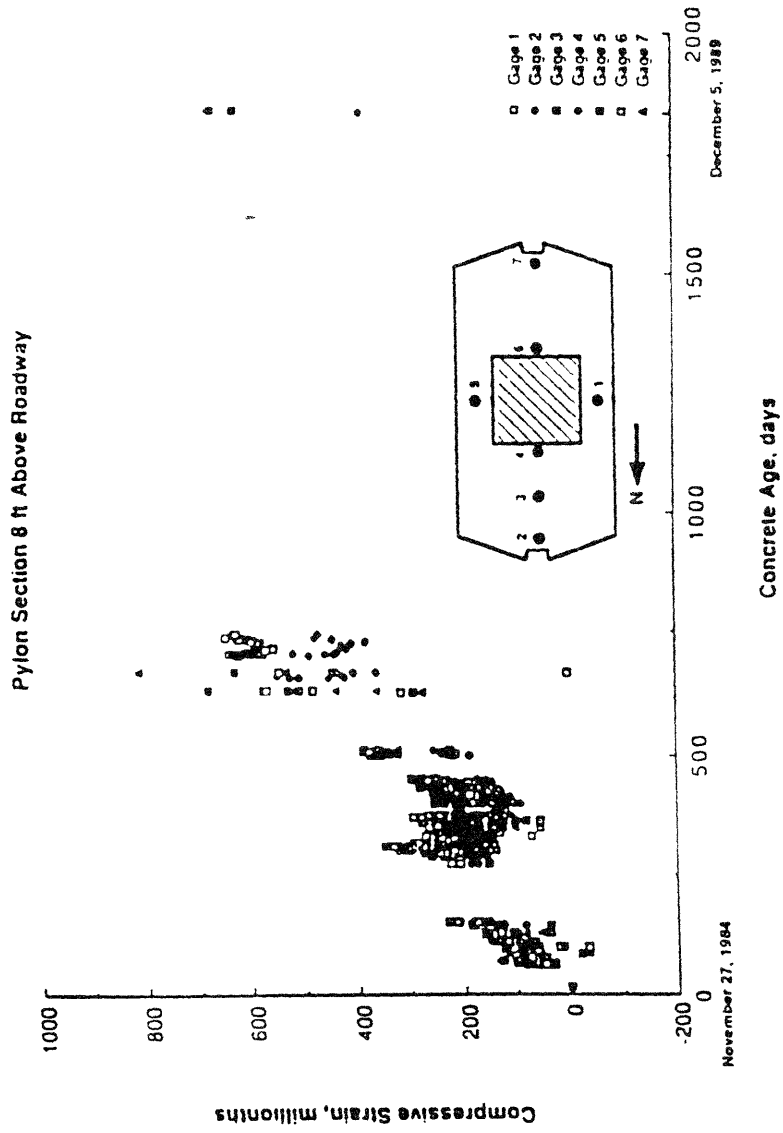

Figure 4-16: Observed Strains for Pylon, 8 ft. Above Road

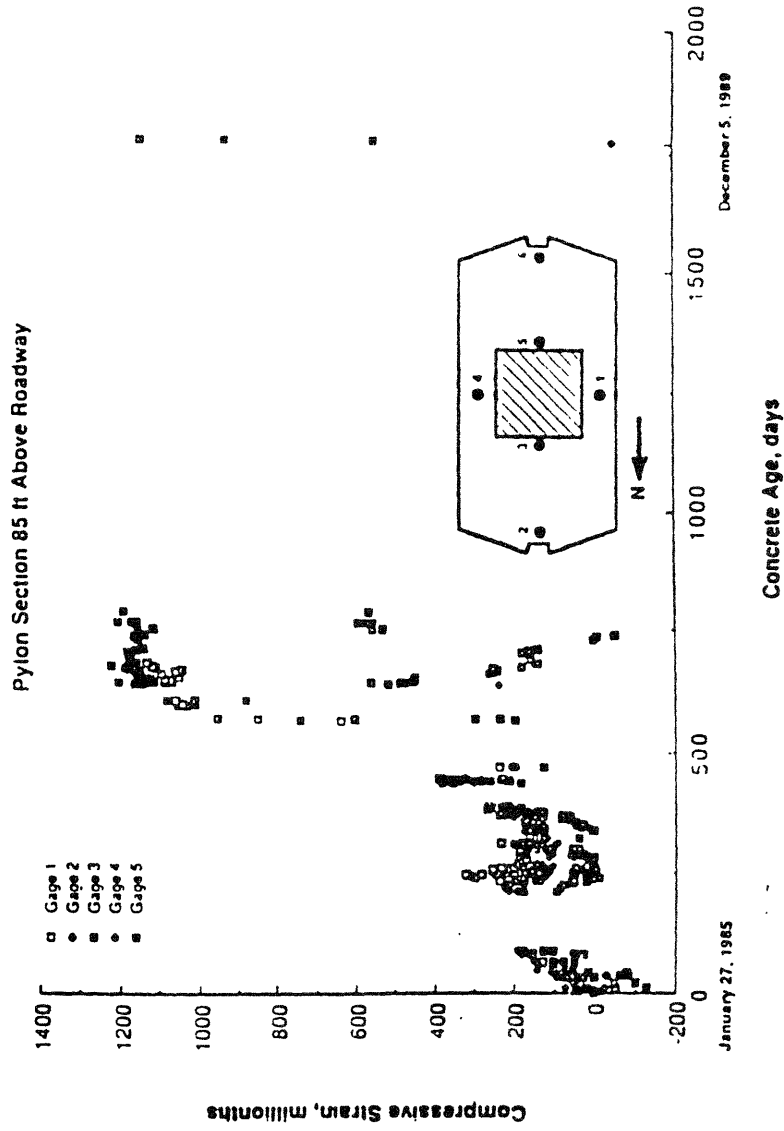

Figure 4-17: Observed Strains in Pylon 85 ft. Above Road

Figure 4-16⁵⁸ and Figure 4-17⁵⁹ present the measured strain histories of the pylon sections at 8 ft. and 85 ft. respectively above the roadway. The pylon sections were instrumented at 8 feet, 85 feet, and 145 feet above the pylon base of pier P1N. Instrumented pier sections were located at 1'-6" and 38' above the impact slab. Three sections were instrumented below the impact slab of piers P1N and P1S besides a pier section at 8 ft. below roadway of pier P1N.

Temperature distributions across the major and minor axes of the pylon sections were measured using 14 thermocouples (Type T). The distribution of the thermocouples at the pylon section 85 feet above the pylon base is shown in Figure 4-18.

⁵⁸ Shahawy, Mohsen. "Comparison of the Analytical and Measured Time-Dependent Strains in the Pylons of the Sunshine Skyway Bridge." Research Report SRR 2-92, Florida Department of Transportation, January 1992

⁵⁹ Ibid.

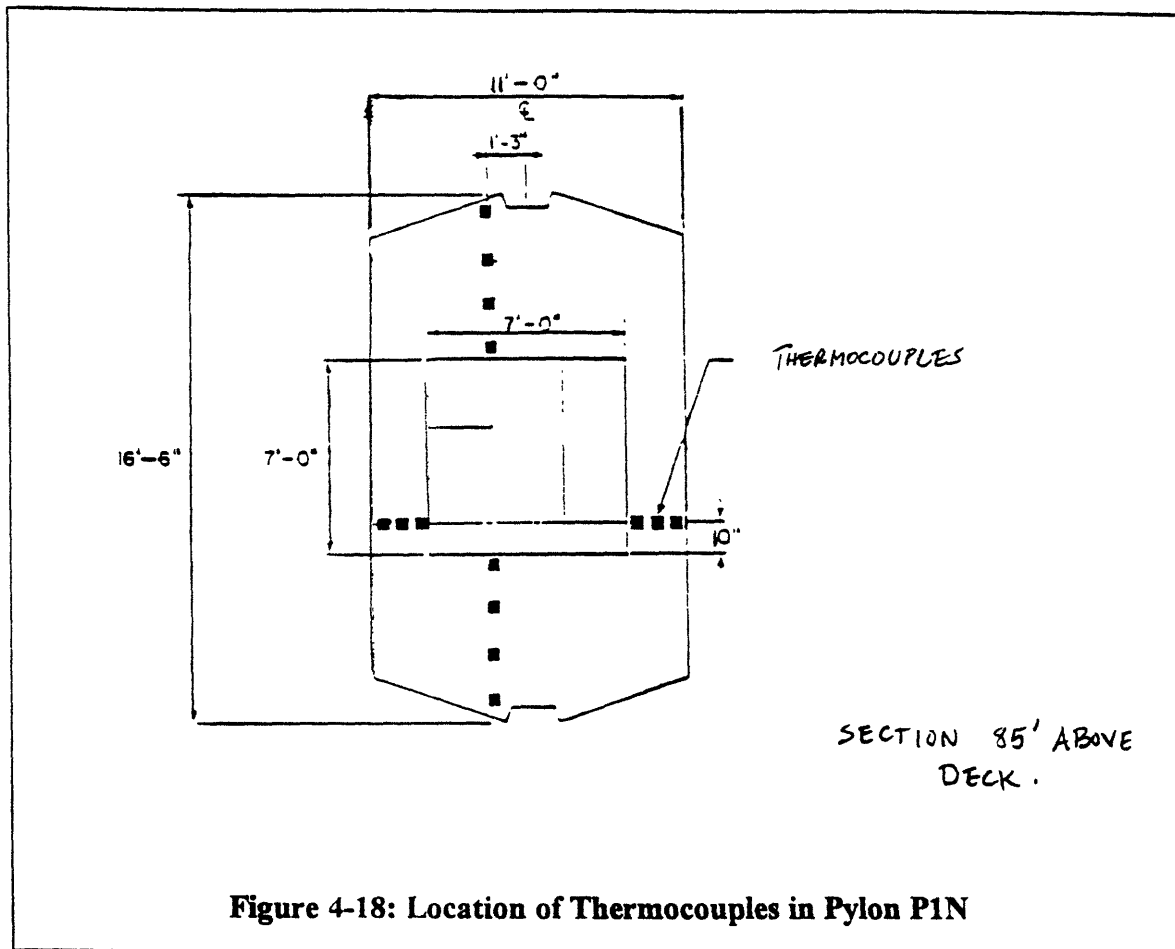

4.4.2 DATA ACQUISITION SYSTEM

The large number of sensors generated a need for an automatic data acquisition system to ensure that consistent and accurate readings were taken and to provide an organized data gathering device. Readings from the installed sensors were measured first manually and then electronically. The readings were taken before and after each event that can cause changes of strain or stress in the instrumented sections. A computer controlled automatic data acquisition system developed at Construction Technology Laboratories was used to acquire the data. Readings acquired manually before installation of the automatic data acquisition system (ADAS) on site included all Carlson strain readings and temperature data. With the large number of installed sensors, an ADAS was used for the

data scanning and recording. A schematic representation of the ADAS is shown in Figure 4-19.⁶⁰

The ADAS produced by Construction Technology Laboratories⁶¹ uses a single microcomputer to read and record over 500 remotely located sensors within minutes. The remote signal processors are located at eight locations in the piers and roadway segments, facilitating the monitoring of all sensors from a single, central location almost simultaneously. The information from these signal processors is fed to a master signal processor. The information is then put into a microcomputer in the field and the laboratory, which allows for data analysis and printing.

The microcomputer contains a time clock which allows readings at pre-programmable times and dates. Typically, manual readings of installed sensors requires the use of two technicians and makes coincidental, quick readings nearly impossible. Scan gages are located over half a mile apart and the digitized signals of the data acquisition system expedites the readings.

The measured strain data represent movements of concrete per unit length along the longitudinal axis of the strain meter. All strain readings were adjusted to a reference temperature of 73° F for comparison purposes, based on the assumption that thermal movements were entirely unrestrained. Compressive strains were measured at different stages for bridge segments and pylon sections.

⁶⁰ Shahawy, Mohsen. "Comparison of the Analytical and Measured Time-Dependent Strains in the Segments of the Sunshine Skyway Bridge." Research Report SRR 3-92, Florida Department of Transportation, January 1992

⁶¹ Shahawy, Mohsen. "Comparison of the Analytical and Measured Time-Dependent Strains in the Pylons of the Sunshine Skyway Bridge." Research Report SRR 2-92, Florida Department of Transportation, January 1992

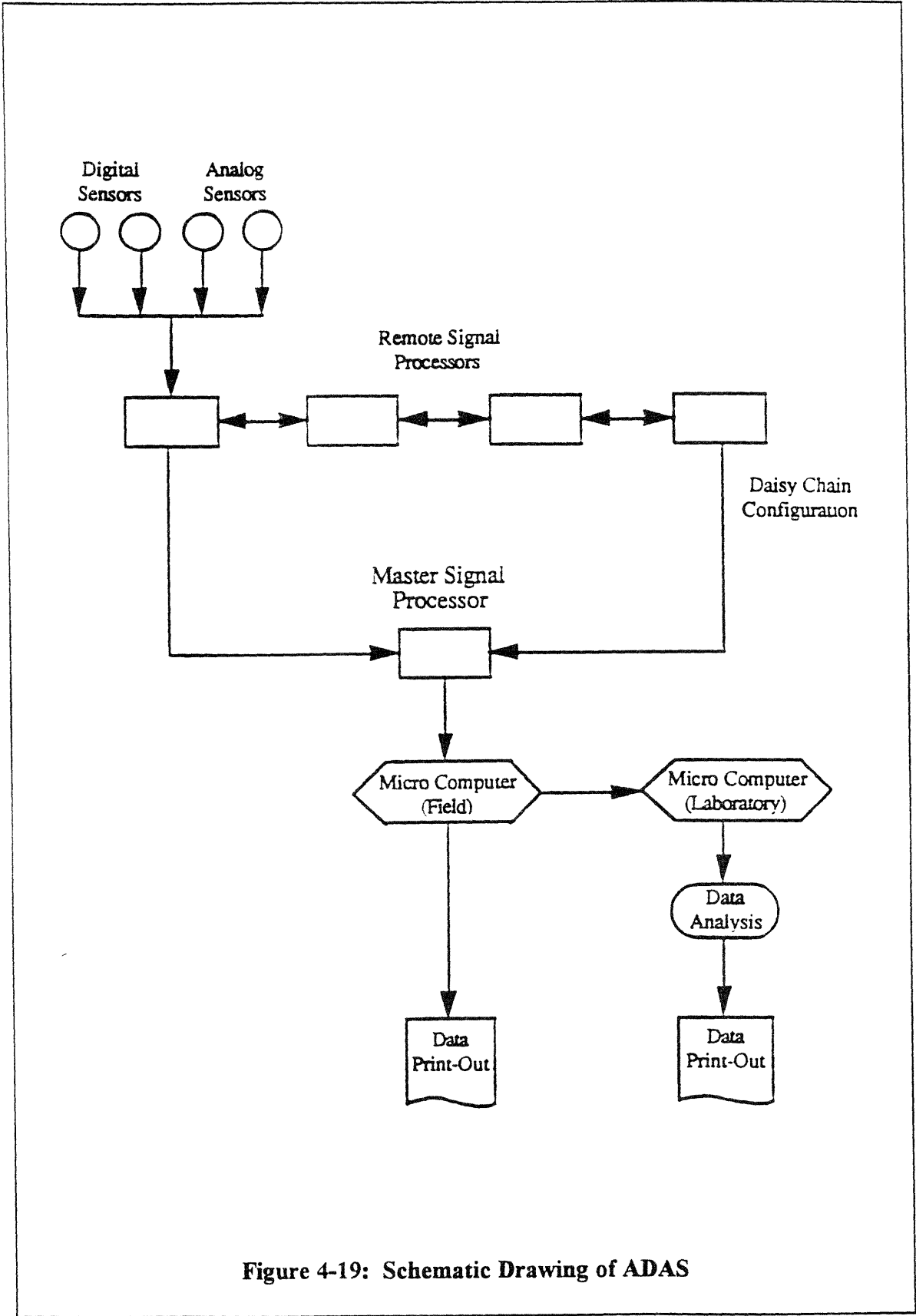

Figure 4-19: Schematic Drawing of ADAS

4.5. INSPECTION AND MAINTENANCE PROGRAM

The instrumentation, while having the ability to supplement the bridge inspections, was intended primarily for research purposes, to verify the insitu behavior with the analytically predicted behavior and laboratory behavior. A visual bridge condition evaluation program, following the AASHTO Manual for Condition Evaluation of Bridges,⁶² is also performed on the structure. Since the instrumentation was discontinued on the structure, this is currently the only condition assessment program.

Inspections are performed on the bridge every two years. This inspection is primarily a visual inspection, and includes underwater inspection and superstructure load rating. The underwater inspection targets locations of deficiencies in the substructure, steel exposure, scouring, cracks, and tip exposure. The inspections have not yielded any proof of any damage- the lack of which has been attributed to the use of dolphins, which serve as a fender system to prevent damage due to scouring.⁶³ Superstructure load rating inspections sought information on deficiency cracks, spalling, steel exposure, and concrete deformation. Crack lengths were measured by strain gauges to an accuracy of 1/32 inches.

Inspections were performed primarily visually, but there was also some application of NDT/NDE. The particular tests used included dye penetrant testing, acoustic emission, and magnetic flux.⁶⁴ Each of these methods was explained in the previous chapter.

⁶² AASHTO. Manual for Condition Evaluation of Bridges. Washington, D.C., American Association of State Highway and Transportation Officials, 1994

⁶³ Hamad Kashani, Florida Department of Transportation, private communication on Decemeber 1, 1995

⁶⁴ Richard Semple, Florida Department of Transportation, private communication on Decemeber 1, 1995

4.6. LAB AND FIELD TESTS ON SEGMENTS⁶⁵

Lab tests were performed on a total of six segments in the high level approach span and in the main cable stayed span using standard 6x12 inch concrete cylinders. Four cylinders were poured for each span. 24 tests were performed on each cylinder by Construction Technology Laboratories. They were shipped to CTL at the age of 1-3 days after the concrete pour, where the molds were stripped and stored at a constant temperature of 73° F and 50% relative humidity. These tests included both long term and short term material property tests. Short term properties that were measured include concrete compressive strength, modulus of elasticity, Poisson's ratio and coefficient of thermal expansion. Six of the 24 cylinders were tested here, the results of which are posted in Table 4-3. The design compressive strength of the bridge superstructure was 5500 psi at 28 days. Long term properties include creep tests and shrinkage tests.

Of the remaining 18 cylinders, six were used to perform creep tests in the lab on the same segments. Creep tests were initiated at concrete ages of 28 days. External mechanical strain gages were used to measure the long term concrete movements. The average longitudinal concrete movements were obtained as the average of the three readings from the mechanical strain gages across target points which are glued on to the concrete surface immediately after mold stripping. Corresponding to each set of shrinkage measurements, a set of creep readings was taken. The creep strains were determined from subtracting the shrinkage measurements from those of the concrete cylinders at a given stress level.

The remaining 12 cylinders were used for creep and shrinkage tests under outdoor conditions for each of the same six segments to evaluate the variation of concrete behavior from testing under indoor conditions. Mechanical strain meters and vibrating wire gages of type VCE 4200 were used in strain measurements. The vibrating wire gauges were

⁶⁵ Shawawy, Mohsen. "Field Instrumentation to Study the Time Dependent Behavior in the Sunshine Skyway Bridge." Research Report No. SRR 01-92, Florida Department of Transportation, January 1992. pg. 10

placed within the center of the cylinder prior to casting, and measured both internal concrete temperatures and longitudinal concrete movements. The mechanical strain measuring device was used to obtain the longitudinal concrete surface movements.

CONCRETE AGE AT TESTING (DAYS)	COMPRESSIVE STRENGTH f_c' , PSI	MODULUS OF ELASTICITY, E, KSI	POISSON'S RATIO	COEFFICIENT OF THERMAL EXPANSION
Segment P3N1N				
7	6450	4390	0.15	--
33	8090	4350	0.20	4.2
11	8290	4320	0.21	--
180	8240	4250	0.17	4.3
Segment P3N10N				
3	5252	3920	0.17	3.6
7	5960	4150	0.17	--
28	6970	3930	0.18	4.3
90	8100	4200	0.20	--
180	7840	4120	0.23	3.1
365	8010	4020	0.26	--
Segment P1N1S				
3	5120	3750	0.19	4.2
7	5820	4160	0.19	--
28	8960	4260	0.19	4.2
90	7600	4740	0.19	--
180	7390	4000	0.14	--
365	7650	3900	0.14	--
Segment P1N5S				
7	6520	4690	0.21	--
28	8010	4840	0.18	4.9
90	8760	5120	0.17	--
180	8660	4710	0.20	--
Segment P1N25S				
3	6430	5700	0.19	4.9
7	7280	5750	0.15	--
28	8870	5580	0.18	5.6
90	9480	6180	0.20	--
180	10,180	5160	0.17	4.3
Segment P1N48S				
3	5440	4060	0.17	--
7	6450	4440	0.15	--

Table 4-3: Physical Properties of Segments After Short Term Tests.

4.7. ANALYTICAL MODEL⁶⁶

Instrumentation's utility does not only lie in the immediate evaluation of a bridge's condition. The data obtained can also prove useful in the long-term understanding of a structure's behavior. Typically an analytical model is used to predict the behavior of a bridge. The results of the model and the instrumentation can then be compared, and the necessary adjustments can be made to the model until the compared results correlate. This section and section 4.8 illustrate this application for the time dependent strain of the Sunshine Skyway Bridge. The basics of the analytical model are discussed and then presented. In Section 4.8, the results are compared with the data from the instrumentation.

4.7.1 OVERVIEW

The analytical model developed predicted the time-dependent strain histories through all stages of construction and thereafter. Included in the model's considerations are the effect of actual forces and moments on the segment sections from casting to complete erection of the bridge. It also simulates the effects of prestressing tendons as well as non-prestressed steel.

Finite elements and time dependent analyses for creep and shrinkage strains were used in the time dependent modeling. The time dependent analyses of the stresses and strains in the uncracked and cracked reinforced/ prestressed concrete sections have been carried out considering the normal forces and moments due to dead loads and prestressing introduced in all stages.

⁶⁶ Shahawy, Mohsen. "Comparison of the Analytical and Measured Time-Dependent Strains in the Pylons of the Sunshine Skyway Bridge." Research Report SRR 2-92, Florida Department of Transportation, January 1992

Figure 4-20: Program CRACK Flow Chart

The CRACK computer program is capable of analyzing reinforced or prestressed concrete members of any cross-sectional shape, having one axis of symmetry. ΔN and ΔM are incremental axial loads and moments. $\Delta\sigma$, $\Delta\epsilon$ are the incremental stresses and strains. "Decompression" implies the decompression of loads and stresses. A , B , I are properties of the transformed uncracked section. ϵ_{cs} is the normal unrestrained shrinkage strain, ϕ is the creep coefficient, χ the aging coefficient, and $\Delta\sigma_{pr}$ is the intrinsic relaxation value.

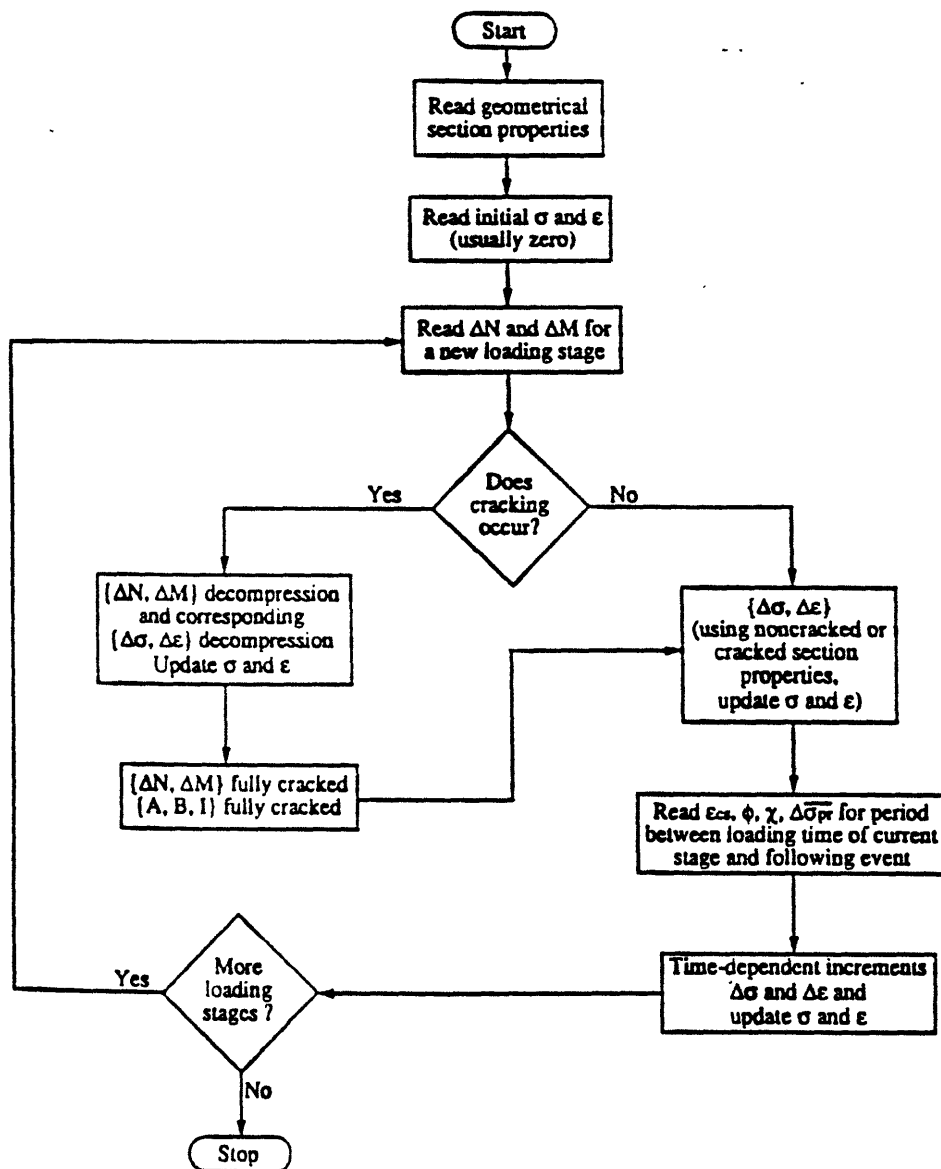

The equilibrium of the internal forces and compatibility of strains are satisfied at all stages of the time dependent analyses. The axial load and bending moment increments at various stages of construction were calculated using a program called GISMA⁶⁷ and then used as input in the time-dependent analysis program CRACK (Figure 4-20).⁶⁸ There is a significant change in the total axial forces and bending moments in the segment sections considered at the stage when the closure segment in the span 1 north of pier PIN is erected. This closure changes the boundary conditions which significantly influences the forces.

4.7.2 CONCRETE ANALYSIS

To analyze the prestressed and reinforced concrete, the program CRACK was used. Figure 4-20 presents the flow chart for the program. CRACK applies the traditional method for evaluating concrete. It is capable of analyzing any member of any cross sectional shape having one axis of symmetry. The program computes the axial loads and moments to be applied on the fully cracked section. The corresponding stresses and strains are computed using non-cracked or cracked section properties. The computer then finds the normal unrestrained shrinkage strain, creep coefficient, aging coefficient, and intrinsic relaxation value, and computes the time dependent increments for stress and strain. It then goes back and updates the original stress and strain values, checks for additional loading stages, and loops back through the process.

The idealized cross section for the time dependent analysis of the pylon sections 8 ft. and 85 ft. above the roadway are given in Figure 4-21.⁶⁹ Figure 4-22 and Figure 4-23 show the idealized cross sections for the segment sections. The following issues were taken into consideration: 1. Cable stay tension and dead weight of the segments, 2. Post

⁶⁷ Shen, T.H., D.H. Libby, and J.F. Abel. "User's Manual for GISMA, Graphical Interactive Structural Matrix Analysis." Cornell University, Ithaca, N.Y., October 1987

⁶⁸ Shahawy, Mohsen. "Comparison of the Analytical and Measured Time-Dependent Strains in the Pylons of the Sunshine Skyway Bridge." Research Report SRR 2-92, Florida Department of Transportation, January 1992

⁶⁹ Ibid.

tensioning of segments (temporary and permanent), 3. Dead weight of the grouted cable stays at the segment nodal points. and 4. Dead weight of the grouted cable stays at the pylon nodal points.

The different load conditions incorporated in the model are as follows: 1a) The stress history of a typical pylon section before cable stay installation is primarily due to the dead weight of the pylon which was erected in stages or 1b) The stress history of a typical segment section before cable stay installation is primarily due to the erection of segments 1 through 6 by the balanced cantilever erection technique used in the construction, 2) Dead weight of the precast segment is incorporated so as to follow the erection sequence, 3) Temporary and permanent post-tensioning forces on the strands are incorporated as axial loads and moments depending upon eccentricity of the strands, 4) Self weight of the grouted cable stays is taken into account as nodal loads at the segment and pylon anchorage locations, 5) Post-tensioning of cable stays are simulated using horizontal and vertical components of the cable stay jacking forces at the segment and pylon nodal points. At the pylon anchorage point, the imbalance in the horizontal components is determined taking into account the differences in the inclinations of the cable stays and cable tensions.

Multiple load cases are accommodated in the multistage analyses of the bridge sequentially to reflect the erection sequence, such as addition of segments, cable stays, temporary and permanent post-tensioning etc. In order to obtain a relative estimate of the pylon strains, load analyses were carried out with four different percentages of prestress loss combinations in the cables and post-tensioning strands.

4.7.3 THERMAL ANALYSIS

A thermal response analysis was performed for the idealized cross section of segment using the FETAB⁷⁰ software for segment PIN1N (designation shown in Figure 4-9). The

⁷⁰ Ghali, A., Elbadry, M., "User's Manual and Computer Program FETAB." October 1982

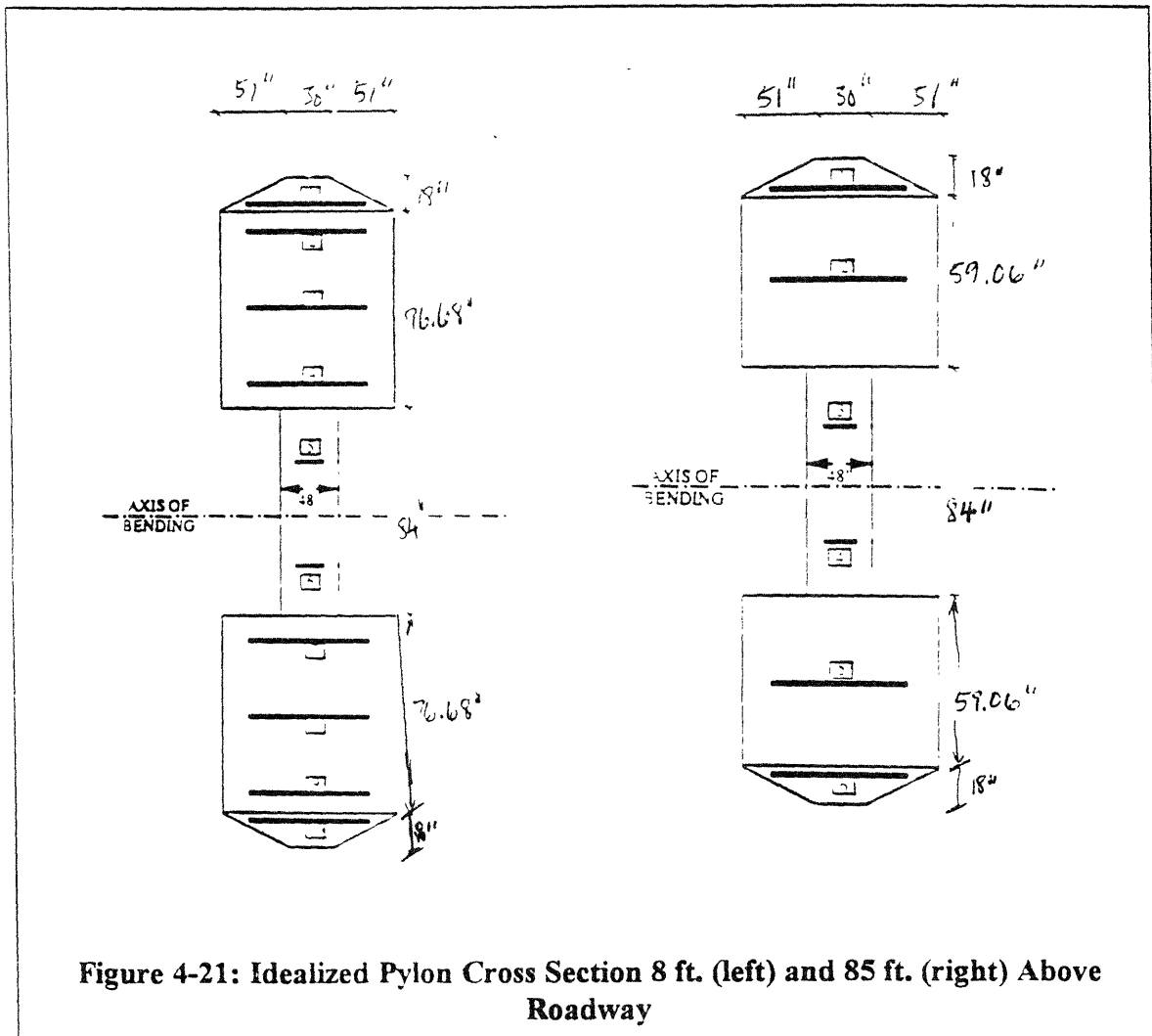

temperature distribution used in the analysis corresponds to the measured value on a typical date. The resulting thermal strains resulting from the continuity moments at the interior supports were determined by assuming the structure to be continuous over five continuous spans.

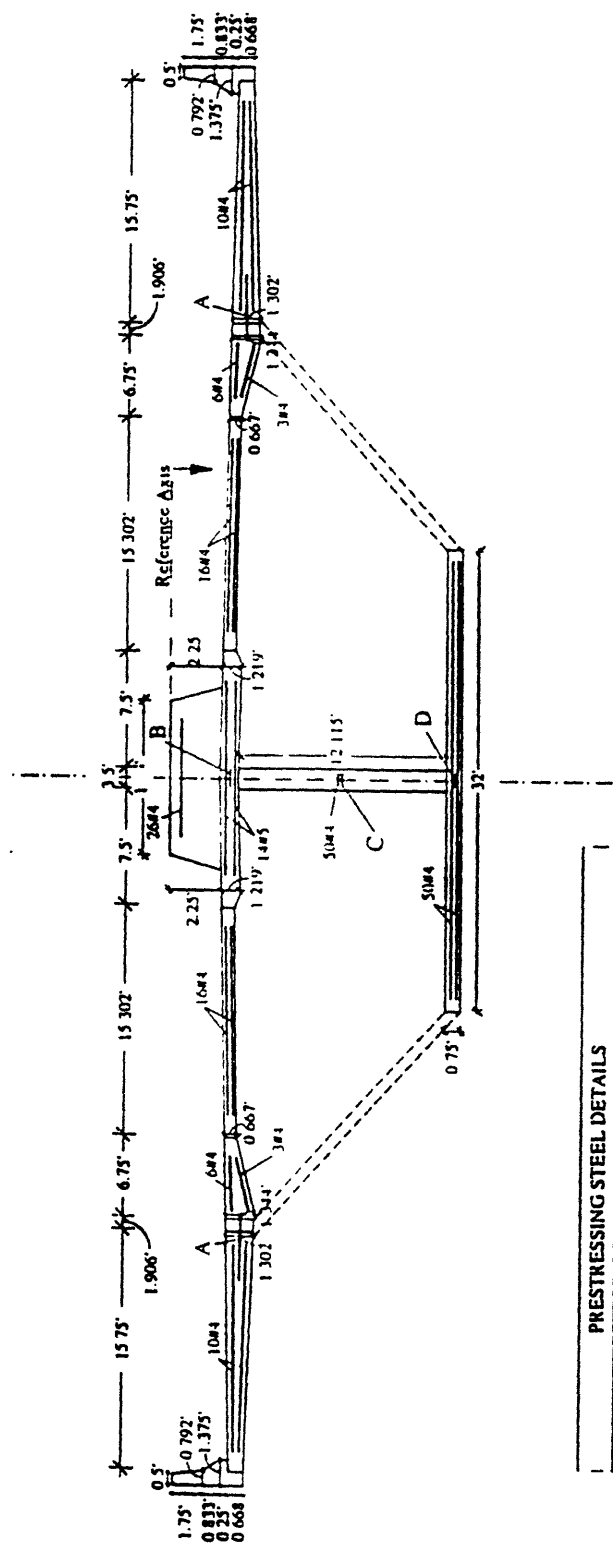

Noncracked transformed sectional properties:

Overall centroid = 6 219 ft
 Area = 184.804 ft²
 Moment of inertia = 5261 05 ft⁴

PRESTRESSING STEEL DETAILS			
Layer	Prestressing Steel	Area (ft ²)	Depth of Centroid (ft.)
A	14(12 wire-0.6")	0.2532	2.901
B	6(12 wire-0.6")	0.1085	2.858
C	8(12 wire-0.6")	0.1447	9.523
D	2(19 wire-0.6")	0.0573	16.622
	6(12 wire-0.6")	0.1085	16.622

Figure 4-23: Idealized Segment Cross Sectional Properties for Span 1N and 1S, Segments 1-4, North of Pier 1N and South of Pier 1S

4.8. RESULTS: PREDICTED VS. MEASURED

In this section the predicted results are presented and compared with the measured data from the instrumentation. The data from the instrumentation simply provides the numerical behavioral properties: e.g. it would provide the data for concrete strain, but it does not explain the behavior. Several analyses were performed assuming varying losses in cable stay tension and post-tensioning forces, and the results of each were compared with the actual measurements obtained from the instrumentation. The bridge generally showed behavior that strongly correlated with one of the scenarios. In this section, the results for the pylon are presented, followed by the results for the segments, each subsection describing the analytical models used, the measured results, and the model that correlated most with the measured data.

4.8.1 PYLON⁷¹

INFLUENCE OF LOSSES ON TIME-DEPENDENT STRAINS.

The time dependent strains calculated are significantly higher than those measured. This variation can be attributed to the differences in the actual forces in the cable stay and post-tensioning strands and those used in the analytical model. In the analytical model, the cable stay and post-tensioning forces were initially assumed to have no losses over time. To account for the variation, new calculations were performed with the assumption that the losses are caused by anchorage slip, relaxation and elastic deformations. A number of analyses were performed assuming varying percentages of losses in the prestressing forces to obtain time-dependent forces and moments.

The cable stay erection sequence had an impact on the strain values. Figure 4-24 and Figure 4-25 present the calculated strain values for the instrumented pylon sections. There

⁷¹ Shahawy, Mohsen. "Comparison of the Analytical and Measured Time-Dependent Strains in the Pylons of the Sunshine Skyway Bridge." Research Report SRR 2-92, Florida Department of Transportation, January 1992

is a notable discontinuity in the strain values between the 14th and 15th load stages. This discontinuity is designated on the figure, and was a result of an inactive time in the actual cable erection sequence. Naturally, the axial forces, moments, and the resulting strains at the pylon sections increase with the erection of additional segments and cable stays. There is a significant variation in the bending moments from the time-dependent analyses, due to the cantilever method construction process used during the erection. Segments were symmetrically added on to either side of the pylon until the closure segment was erected at the center of the main span. This caused the structure to become statically indeterminate with basic changes in the boundary conditions. When the segments reach the P2N support, the structure becomes a simply supported span, with overhangs on either side, thereby causing the aforementioned variations.

The axial forces and bending moments were recalculated for the 8 ft. and 85 ft. pylon sections on the basis of 20% losses in prestress and cable stay forces and 20 % loss in prestress and 10% loss in cable stay forces. The observed forces and moments show a reasonable correspondence to the recalculated values.

TIME-DEPENDENT DEFORMATION RELATIONSHIPS

The observed strains correspond reasonably with those strains calculated using 20% losses in both the stay and prestress forces (Figure 4-16, Figure 4-17, Figure 4-24, and Figure 4-25⁷²). The strains in the pylon section at 8 ft. are smaller than those at the 85 ft. section, which have been attributed to the larger sectional properties at 8 feet, since the axial force increments are relatively similar. The time-dependent strains in the sections during the inactive period of construction are almost negligible.

⁷² Shahawy, Mohsen. "Comparison of the Analytical and Measured Time-Dependent Strains in the Pylons of the Sunshine Skyway Bridge." Research Report SRR 2-92, Florida Department of Transportation, January 1992

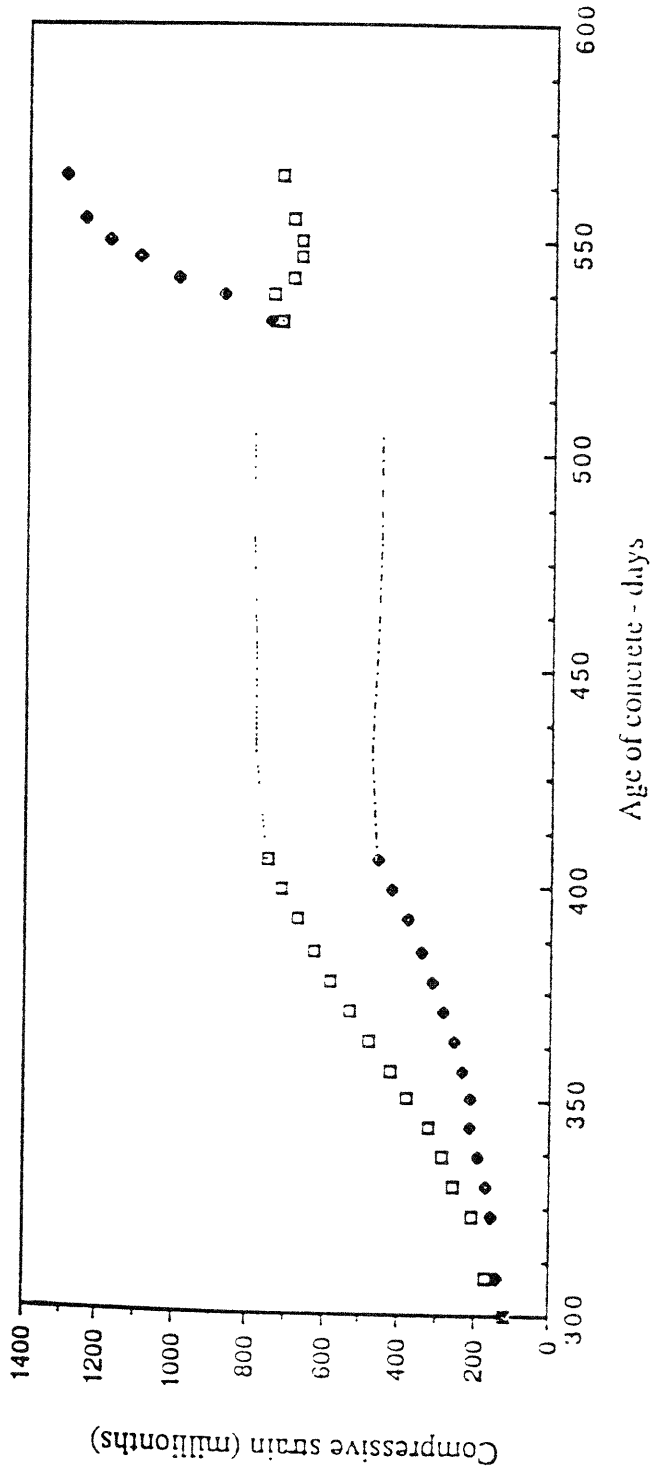

Fig. 14 Predicted strain variations in pylon section 8ft. above the roadway

- Top fiber - Eqn. 5
- Bot. fiber - Eqn. 6
- Time-dependent strain in the top fiber between load stages 14 and 15
- Time-dependent strain in the bottom fiber between load stages 14 and 15

Figure 4-24: Calculated Strain in Pylon, 8 ft. Above Rd.

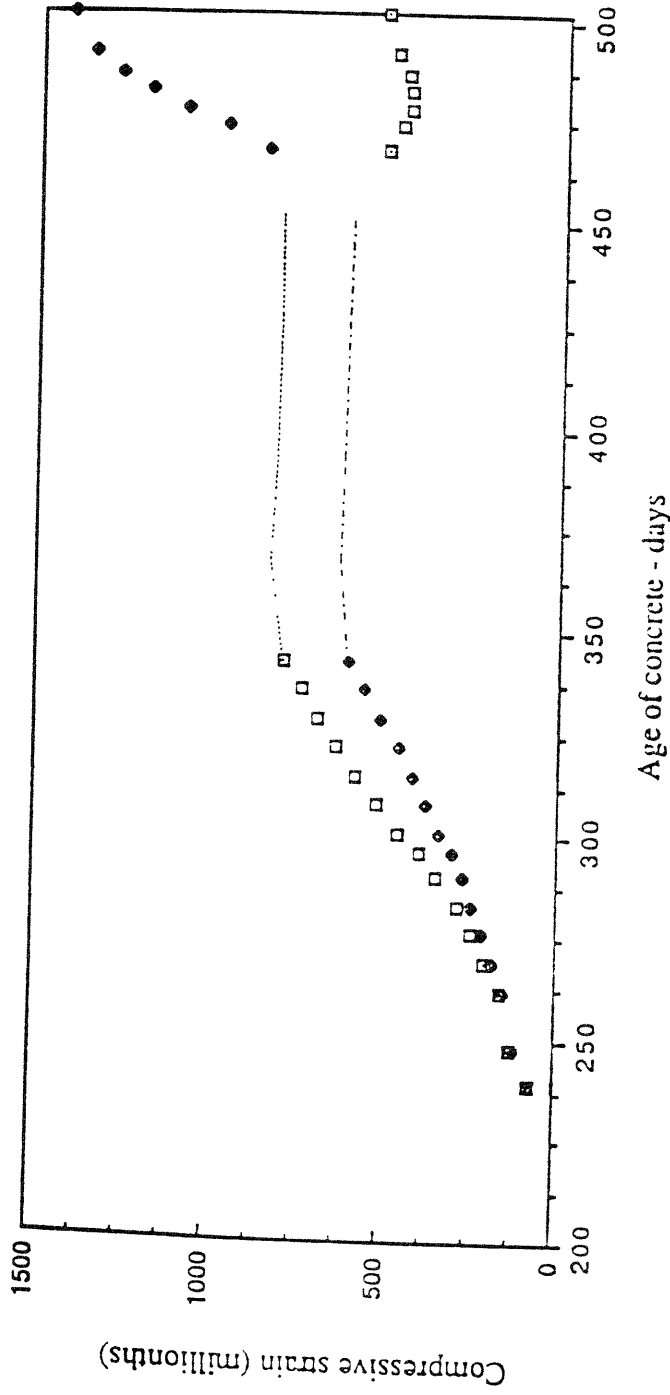

Fig. 15 Predicted strain variations in pylon section 85 ft. above the roadway

- Top fiber - Eqn. 7
- ◆ Bot. fiber - Eqn. 8
- Time-dependent strain in top fiber between load stages 14 and 15
- Time-dependent strain in the bottom fiber between load stages 14 and 15

Figure 4-25: Calculated Strain in Pylon, 85 ft. Above Road.

4.8.2 SEGMENTS⁷³

INFLUENCE OF LOSSES ON STRAINS

An analysis of the forces and moments in typical segment section of the bridge was performed first assuming no losses in the cable stays and in the prestressing forces. When compared to the measured values, it was found that the predicted values were considerably higher than the measured values. Thus, another analysis was performed, assuming 20% losses both in the cable and the prestressing forces. Bridge segment P1N1N was evaluated for both measured and analytical values. The multistage load analysis indicated forces which would produce higher compressive stresses in the bottom fiber. The measured values in the segment corresponded with this prediction. The analytical values, however, proved to be higher than the measured values so another analysis applying 20% loss in prestress in post-tensioning cables and 10% loss in cable-stay forces was performed. This provided the closer relation between analytical and measured values as desired. As time went by, there were found to be negligibly small tensile strains in the top fiber, unlike the compressive strains demonstrated earlier in the measurements. In the pylon, this did not occur. Thus, there was relative comfort with the losses taken in the post-tensioning strands and the cable stays because of the close values. The difference in the segments' values was then attributed to uncertainties in variables such as the ambient air temperatures, wind and degree of support restraint. The air temperature was then incorporated into the model.

AMBIENT AIR TEMPERATURE INFLUENCE

It was concluded that the rapid temperature changes in the air surrounding the bridge was inducing non-linear thermal gradients in the cross section. These gradients were

⁷³ Shahawy, Mohsen. "Comparison of the Analytical and Measured Time-Dependent Strains in the Segments of the Sunshine Skyway Bridge." Research Report SRR 3-92, Florida Department of Transportation, February 1992

producing a considerable amount of self equilibrating stresses in the bridge structure. Additionally, the continuous nature of the bridge structure provoked the generation of continuity moments in the interior supports due to the thermal elongation restraints of the bridge deck. These contributed to the total thermal stresses and strains, and were sufficient to double the total magnitude of strain at certain fibers of the cross section.

	TOP FIBER	BOTTOM FIBER
	micro strains, (-) is compressive and (+) is tension	
1) Analytical Model	-50 to -75	-1300
2) Calculated Thermal Resonse		
a) Self equilibrating	-410	-87
b) Continuity	-120	248
Total Strain including thermal effect	-580 to -605	-1139
Measured Time Dependents Strains	-400 to -600	-800 to -1100

Table 4-4: Thermal Strains

The predicted strains in the top fiber were demonstrated to be predominantly tensile as opposed to the measured values, which said they were compressive. The thermal strains that were unaccounted for in the model would explain this in the measured values. The thermal analysis described earlier was applied (see section 5.2). The results of this analysis in comparison to the measured values are presented in Table 4-4.

4.9. DISCUSSION

The use of instrumentation proved useful in evaluating the reliability of the analytical models. It was clearly demonstrated in both the segments and the pylons that the initial analytical model was inaccurate, and that some allowances needed to be made for losses and air temperature. This allowed for refinement of the analytical model.

Since the original predictions for strain were higher than the observed values, there was no need for redesign or corrective action. In fact, the lower actual strain values suggest that the bridge may have been over-designed. The instrumentation program was

discontinued a few years after construction, so there is no way to verify this through a long term analysis.

The instrumentation program proved to be a useful part of understanding the Skyway Bridge. From the above results, it is clear that the availability of actual data to confirm the calculated values led to a better understanding of that structures behavior.

5. EVALUATION

5.1. CONTINUOUS MONITORING

Bridge deterioration is unavoidable, whether due to a catastrophic event or due to the everyday wear on the structure from weather or loading. Traditional condition evaluation through biennial inspections usually only locates the deterioration when it has reached near critical levels. This results in a higher cost of repair than if the flaws were located at their inception. Unfortunately, most of the time, these flaws remain hidden to visual inspection. The search for the solution to this has led to the development of new technologies, the most significant being nondestructive testing.

The advent and expansion of nondestructive testing (NDT) has improved the inspector's ability to locate flaws unnoticeable to the naked eye. The methods discussed in chapter 2 are the most commonly used methods, but there are many that remain unused.

The criteria used for choosing the testing method does not always include the method's accuracy. NDT processes can require the use of large, expensive equipment that requires a high level of technical expertise to operate. While they may be comfortably and commonly used in research, those characteristics preclude their use in actual field inspections. It is costly and time consuming to train people to use equipment which is also expensive and difficult to bring to the field. Thus, often the NDT methods being used are not always the state of the art. Typically the methods gain usage as their accuracy improves and the equipment becomes more portable, cheaper, and easier to operate.

The NDT methods that are used in the field are better than traditional visual inspection, but they still only provide an elemental evaluation of the bridge and its deterioration. While the results from an elemental analysis can provide implications on the entire structure of the bridge, they do not provide a solid, quantitative evaluation of the whole structure. Instrumentation is a tool that could provide this. The proper installation of sensors with a data acquisition system allows for quick and accurate condition evaluation of the structure on a global level.

One current problem with the use of instrumentation is that it is fairly costly. The embedding of the instruments in the structure, the development of a data acquisition system with both hardware and software, and the training of people to monitor the system are all be aspects of the cost. At the same time, instrumentation removes the cost inspection and reduces the cost of maintenance. Any necessary rehabilitation could be performed early instead of at a critical stage, thereby reducing the concern and cost of potential rehabilitation of the entire structure. Deterioration acts as a disease; if it is not taken care of quickly, it can put strain on other members of the structure, weakening them, until the entire structure become deficient.

Instrumentation would also provide a greater understanding of not only the behavior of the bridge being monitored, but all bridge structures of that type. The continuous quantitative data can be input into analytical models to verify the assumptions. Mistakes can be identified and examined, leading to a new, in depth understanding of bridge

structures. With each new understanding comes another step towards developing more efficient and economical structures that can also be aesthetically pleasing.

Instrumentation will become cheaper as the cost of the data acquisition systems decrease. The application of sensor technology supported by automated acquisition systems is increasing in many fields. This increased application is resulting in cheaper, more user friendly developments in both sensor technology and acquisition systems. This will expedite its implementation in inspection applications. Currently it is used in more of a research capacity for material and design knowledge. The permeation into inspection and maintenance will be slow, but is logical. In the long run, when considering the entire life cycle cost of a structure, it will be the most efficient and economical tool for both condition evaluation.

5.2. SUNSHINE SKYWAY BRIDGE

Continuous monitoring of the Sunshine Skyway Bridge successfully demonstrated a few of the benefits of instrumentation. This program proved that instrumentation is a valuable method of establishing the reliability of analytical models, structural behavior, and design assumptions. The presence of instrumentation during construction and for a few years following the completion of construction helped defined the loading experienced by the bridge and their effects. It was possible to verify the quality of the fabrication techniques for the concrete segments. Unfortunately the instrumentation was disconnected, and the benefits of long term instrumentation could not be realized. One of the potential benefits of instrumentation that had been identified from the start but was not addressed included the use of instrumentation as an inspection and maintenance aid.

Construction Technology Laboratories (CTL), who designed and managed the instrumentation program, had suggested that the instrumentation would assist in

maintenance by indicating the potential for problems before they are visible to inspectors.⁷⁴ This benefit was not realized. The instrumentation was disconnected in two years, before the need for an inspection even arose.

Another benefit that instrumentation of the Sunshine Skyway Bridge could have provided was the provision of baseline information to help analyze the assumptions of long-span concrete bridge design. CTL had identified this possibility before the instrumentation had been disconnected. There are, however, no documents showing the realization of this goal.

The utilization of the full range of capabilities of instrumentation would have provided not only data specific to the analysis of the Sunshine Skyway Bridge, but a valuable example of the multiple capabilities of instrumentation. If one system was demonstrated to expedite analysis, verify fabrication techniques, assist in inspections, and verify design assumptions, then the cost savings could be presented. A reasonable feasibility model of instrumentation could be established. The Sunshine Skyway demonstrates only a portion of the strengths of instrumentation. There are further benefits that could be shown through a more long term instrumentation program.

⁷⁴ "Bridge Builder's Primary Concern is With Safety." *Engineering News-Record*, v. 215, Aug. 8, 1985, pg. 30-1

6. CONCLUSION

6.1. SUMMARY

This thesis presented the application the concept of instrumentation to bridges, specifically to supplement inspection and maintenance. The basic inspection criteria and structure is first presented, to demonstrate its subjectivity and inaccuracy. This is then followed by a description of the concept of instrumentation and its fundamental components. The chapter on instrumentation represents only a few ideas on the instrumentation of a bridge; there are no absolute guidelines for such a program, thus, there is a lot of flexibility in what is presented in terms of sensors to use or not use and ADAS structure.

To demonstrate the usage of instrumentation, the case of the Sunshine Skyway Bridge is presented. This study provides insight into only one advantage of instrumentation: its ability to assist in the evaluation of analytical methods and assumptions. The results demonstrate the comparison of predicted results vs. measured data, followed by analyses

to allow the fitting of the analytical model to support the actual data. Through the use of instrumentation, the accuracy of a prediction model can be established. In trying to retrofit the model to the data, the behavior of a bridge can be better understood. Analysis after the initial comparison of calculated vs. observed data produced information on percentage of cable stay tension loss and thermal losses

The information presented on inspection, instrumentation, and the Sunshine Skyway are evaluated in Chapter 5. The conclusions are presented here after.

6.2. CONCLUSION

Instrumentation presents a wide range of opportunities in bridge evaluation, design, and construction. Instrumentation was used in the Sunshine Skyway to verify design assumptions and improve understanding of its structural behavior. It is clear that instrumentation would also be useful in the construction process, particularly the balanced cantilever method, by providing immediate, accurate values on camber and deflection, thus expediting and confirming a proper installation of segments (discussed in section 3.1). Its application to bridge condition evaluation is a logical next step.

The ability to expedite and quantify deterioration is unique to machines; therefore expansion to a global evaluation procedure by instruments is necessary. This is demonstrated in the increasing application of nondestructive evaluation methods in bridge inspections. These methods supplement quantitative bridge inspection data. On a global level, actual, quantitative data is more difficult to obtain. Instrumentation could provide this global data.

With instrumentation technology advancing, the cost effectiveness is increasing. This is particularly significant with the growing awareness that life cycle costs need to be incorporated into the planning and design stages. The advancing technology also produces technically simpler machines, making them easier to operate. They are becoming

a more viable method, but further studies and projects will need to be undertaken by the Federal Highway Administration to do a precise feasibility analysis.

6.3. FUTURE IMPLICATIONS

The application of instrumentation technology to bridge engineering would be a valuable contribution to the entire inspection, maintenance, design, and analysis process. Its future use is precluded, however, by its current high cost and complex technical application. The increasing concern over the state of the nation's infrastructure could play a significant role in expediting this application.

The significance of including the entire life cycle costs of a bridge in its design, analysis, inspection, and maintenance can not be over-emphasized. It is this consideration that would overcome one of the primary obstacles to the practical application of instrumentation: its high cost. Since instrumentation reduces the cost of maintaining a bridge by locating deterioration in early stages, it is most cost effective in a long term application.

The other obstacle to the use of instrumentation in practical application, its technical complexity, will only be overcome as technology progresses. Typically, technology progresses the fastest by frequent usage. Even though structural engineering has a limited implementation of instrumentation programs, all aspects of instrumentation are advancing by its growing application in other fields. Thus, with obstacles more or less removed, the use of instrumentation will increase. It is really just a matter of time.

REFERENCES

Listed alphabetically, with page references.

REFERENCE	PAGE NUMBERS
“Bridge Builder’s Primary Concern is With Safety.” <i>Engineering News-Record</i> , v. 215, Aug. 8, 1985, pg. 30-1	49, 50, 88
“Engineers Hit Florida DOT for Decisions on Major Jobs.” 2 February 1984	50
“Skyway Bridge Boasts a Record and Innovations.” ENR, September 11, 1986, pg. 20-23. See bibliography.	38
“Skyway pier cracks probed.” <i>Engineering News Record</i> , v. 211, Nov. 17, 1983, pg. 12	50, 51
AASHTO. “Guidelines for Bridge Management Systems,” Washington D.C., American Association of State, 1994	23
AASHTO. Manual for Condition Evaluation of Bridges. Washington, D.C., American Association of State Highway and Transportation Officials, 1994	68
Based on survey of state bridge engineers performed at MIT	16,18
Bettigole, Neal H. “Bridge Management and Life Cycle Cost.” <i>Restructuring America and Beyond Structures Congress</i> , Proceedings v 1, 1995, pg. 668-669	24
Chang, K. C., S. Shen, and G. C. Lee. “Modal Analysis Technique for Bridge Damage Detection.” <i>Structural Engineering in Natural Hazards Mitigation</i> , v 2, 1993, pg. 1083-89.	20
de Brito, J., Branco., F.A., and Ibanez. M. “A Knowledge Based Concrete Bridge Inspection System.” <i>Concrete International</i> , February 1994, pg. 59	15,
Di Vietro, Philip. “Monitoring a Bridge’s Pulse.” <i>Civil Engineering</i> , v. 56, March 1986, pg. 54-55	39
Dunker, Kenneth F., Rabbat, Basile. “Assessing Infrastructure Deficiencies: The Cases of Highway Bridges.” <i>Journal of Infrastructure Systems</i> , v 1, n 2, June 1995	21,27
Ghali, A., Elbadry, M., “User’s Manual and Computer Program FETAB.” October 1982	74

Grant, Albert A. "Civil Infrastructure Systems: The Big Picture." <i>Journal of Infrastructure Systems</i> , June 1995, pg. 78-81	8,
Grippio, Gerard. "Structrual Condition Monitoring of Concrete Bridges." Term Paper, MIT, November 1994.	11, 15, 16, 32
Hearn, George. "Structural Engineering Applications in Bridge Management Systems." <i>Restructuring America and Beyond Structures Congress</i> , Proceedings v 1, 1995.	28
Hyman, W.A. and R. M. Alfelor and T.M. Alexander. "Field Demonstration of Advanced Data Acquisition for Maintenance Management." National Cooperative Highway Research Program, Report 361, 1993	26
Kashani, Hamad. Florida Department of Transportation, private communication on Decemeber 1, 1995	68
Markow, Michael J., "Highway Management Systems: State of the Art." <i>Journal of Infrastructure Systems</i> . September 1995	26
Menn, C., <i>Prestressed Concrete Bridges</i> , Birkhauser Verlag AG Basel, Germany, 1990.	9, 10
Morton, Alan. Figg and Muller Engineers Inc., private communication, July 1995	86
NCHRP. "Field Demonstrations of Advanced Data Acquisition Technology for Maintenance Management." National Cooperative Highway Research Program, Report 361, 1993	26
Pettey, James M. "Monitoring Performance of Full Scale Structures." <i>Natural Hazards Mitigation</i> , vol 2, pg. 1596-1601	35
Potter, Jerry. Florida Department of Transportation. private communication, August, 1995	38
Rada, Gonzolo R., Aramis Lopez, Gary Elkins, Cheryl Richter, and Brandt Henderson. "Long-Term Pavement Performance Program: Instrumentation Selection and Installation." <i>Transportation Research Record</i> . n 1432, 1994, pg. 32-43	33
Semple, Richard Florida Department of Transportation, private communication on Decemeber 1, 1995	68
Shahawy, Mohsen. "Comparison of the Analytical and Measured Time-Dependent Strains in the Pylons of the Sunshine Skyway Bridge." Research Report SRR 2-92, Florida Department of Transportation, January 1992	38, 39, 60, 64, 66, 71, 73, 78, 79
Shahawy, Mohsen. "Comparison of the Analytical and Measured Time-Dependent Strains in the Segments of the Sunshine Skyway Bridge." Research Report SRR 3-92, Florida Department of	51, 59, 66, 82

Transportation, January 1992

- Shawawy, Mohsen. "Field Instrumentation to Study the Time Dependent Behavior in the Sunshine Skyway Bridge." Research Report No. SRR 01-92, Florida Department of Transportation, January 1992. 39, 51, 55, 69
- Shen, T.H., D.H. Libby, and J.F. Abel. "User's Manual for GISMA, Graphical Interactive Structural Matrix Analysis." Cornell University, Ithaca, N.Y., October 1987 73
- Sheth, Arun P. "Design Considerations: A High Performance Integrated Data Acquisition System." *Proceedings of the 38th International Instrumentation Symposium*, 1992, pg. 409-416 34
- Shiu, Kwok-Nam and Henry G. Russell. "Effects of Time-Dependent Concrete Properties on Prestress Losses." *Canadian Journal of Civil Engineering*, vol 14, 1987, pg 649-654. 30, 31
- Sunshine Skyway Bridge, Drawings and Specifications, by Figg and Muller Engineers Inc. 1982 40, 41, 43, 48
- Tang, Jhy-Ping., and Ker-Ming Leu. "Vibration Measurement and Safety Assessment of Bridges." *Journal of the Chinese Institute of Engineers*, vol. 11, no 5, pg. 543-549 20
- Waggoner, Holly. *Skyway to the Sun*. Omnigraphi Publishers, c. 1988 49, 87
- Wipf, Terry J. "Use of Tilt Sensing Equipment for Monitoring Long-Term Bridge Movement." *Canadian Journal of Civil Engineering*. vol 18, 1991, pg. 1033-1046 29
- Yanev, B.S. "Bridge Management: A Panel Discussion." *Restructuring America and Beyond Structures Congress, Proceedings v 1*, 1995, pg. 666-667 15, 25

SELECTED BIBLIOGRAPHY

1. "All Bids for Bridge Go Steel." *ENR*, v. 217, Dec. 18, 1986, pg. 23
2. "Bids Due on Record Span." *Engineering News-Record*, v. 211, Dec. 8, 1983, pg. 13
3. "Bridge Builder's Primary Concern is With Safety." *Engineering News-Record*, v. 215, Aug. 8, 1985, pg. 30-1
4. "Bridge Inspection Simplified." *Engineering News Record*, v. 236, March 28, 1994, pg. 55
5. "Bridge is Stayed Above and Below." *Engineering News Record*, v. 215, July 18, 1985, pg. 28
6. "Bridge Stressing Beefed Up." *Engineering News-Record*, v. 216, Jan. 2, 1986, pg. 16
7. "Cable Stayed Bridge Fails in Korea." *ENR*, v. 229, Aug. 10, 1992, pg. 7-8
8. "Cable-stayed Bridge Job Bid 36 Under Estimate." *Engineering News Record*, v. 211, Sept. 15, 1983
9. "Clean Lines for Bridge Option." *Engineering News Record*, v. 211, Dec. 8, 1983, pg. 13-14
10. "Computer Models Mishap." *Engineering News Record*, v. 213, Sept. 13, 1984, pg. 13
11. "FHWA Funds Fiber Research." *Engineering News Record*, v. 230, May 3, 1993, pg. 16
12. "Florida Bridge Woes Persist." *Engineering News Record*, v. 214, May 23, 1985, pg. 15
13. "Florida Legislators Dismiss Criticism of Sunshine Skyway Bridge." *Engineering News Record*, v. 212, Feb. 16 1984, pg. 12
14. "Knock Down Prices Wanted." *Engineering News Record*, v. 226, Jan. 14, 1991, pg. 13
15. "More Money Requested by Late Contractor." *Engineering News Record*, v. 213, July 19, 1984, pg. 27-28
16. "Negligence is Charged in Bridge Gantry Failure." *Engineering News Record*, v. 214, June 27, 1985, pg. 12-13
17. "New Overpass Overlap Flap." *Engineering News Record*, v. 211, Dec. 22, 1983, pg. 15
18. "Niggling Problems Plague Sunshine Skyway Bridge Job." *Engineering News Record*, v. 212, March 15, 1984, pg. 13
19. "Signal Conditioning for Instrumentation." *Electronics World and Wireless World*, v. 99, July 1993, pg. 560-1
20. "Skyway pier cracks probed." *Engineering News Record*, v. 211, Nov. 17, 1983, pg. 12
21. "Stayed Cable Fills the Gap." *Engineering News Record*, v. 211, Sept. 22, 1983, pg. 15

22. AASHTO. "Guidelines for Bridge Management Systems," Washington DC, American Association of State
23. Abdel-Ghaffer, A.M., Niazy, Abdel-Salam, M., Moori, Sami. "Analysis of the Seismic Records of a Suspension Bridge." *Proceedings of the Symposium on Structural Engineering in Natural Hazards Mitigation*, Volume II, 1993
24. Abdel-Ghaffer, Ahmed M., Khalifa, Magdi A. "Importance of Cable Vibration in Dynamics of Cable-Stayed Bridges." *Journal of Engineering Mechanics*, v. 117, Nov. 1991, pg. 2571-89
25. Aboul-ella, Fakhry. "Analysis of Cable-Stayed Bridges Supported by Flexible Towers." *Journal of Structural Engineering*, v. 114, Dec. 1988, pg. 2741-54
26. Alampalli, Sreenivas and Fu, Gongkang "Full Scale Dynamic Monitoring of Highway Bridges." *Proceedings of the Symposium on Structural Engineering in Natural Hazards Mitigation*, Volume II, 1993
27. Anderson, David., Johnson, Richard., Leon, Roberto. "Transverse Load Distribution in a 536-ft. Deck Arch Bridge." *Transportation Research Record*, n 1180, pg. 90-93
28. Arun P. Sheth. "Design Considerations: A High Performance Integrated Data Acquisition System." *Proceedings of the 38th International Instrumentation Symposium*, 1992, pg. 409-416
29. Based on survey of state bridge engineers and Gerard Grippo, Bridge Inspector for A. G. Lichtenstein and Associates, Boston, MA. January 1995
30. Bierman, Robert. "Thermocouples: What are They? When Should They Be Used? Which Thermocouples Should Be Used?" *ASTM Standardization News*, v. 16, May 1988, pg. 40-42
31. Billington, David P., Nazmy, Aly. "History and Aesthetics of Cable-Stayed Bridges." *Journal of Structural Engineering*, v. 117, Oct. 1991, pg. 3103-34
32. Bottigolo, Neal H. "Bridge Management and Live Cycle Cost." *Restructuring America and Beyond Structures Congress*, Proceedings v 1, 1995, pg. 668-669
33. Bruneau, Michel. "Evaluation of System Reliability Methods for Cable Stayed Bridge Design." *Journal of Structural Engineering*, v. 118, April 1992, pg. 1106-20.
34. Cappa, P., Sciuto, S. A. "An Experimental Analysis of the Metrological Performances of an Automatic Thermocouple Instrumentation System Conducted by a Simple Calibration Setup." *Experimental Techniques*, v. 18, Sept./Oct. 1994, pg. 19-23
35. Chang, K. C., S. Shen, and G. C. Lee. "Modal Analysis Technique for Bridge Damage Detection." *Structural Engineering in Natural Hazards Mitigation*, v 2, 1993, pg. 1083-89
36. Cleaveland, Peter. "New Portable Instruments Include Temperature Calibrator and Data Acquisition System." *I&CS*, v. 67, Nov. 1994, pg. 82
37. Cofrancesco, Pacifico., Ruffina, Umberto., and Villa Marco. "A Digital Temperature Control System." *Review of Scientific Instruments*, v. 62, May 1991, pg. 1311-16
38. de Brite, J., Branco, F. A., and Ibanez, M. "A Knowledge Based Concrete Bridge Inspection System." *Concrete International*, v 16, n2, Feb. 1994, pg. 59-63

39. de Brito, J., Branco., F.A., and Ibanez. M. "A Knowledge Based Concrete Bridge Inspection System." *Concrete International*, February 1994, pg. 59
40. Di Vietro, Philip. "Monitoring a Bridge's Pulse." *Civil Engineering*, v. 56, March 1986, pg. 54-55
41. Dilger, W. H., Tadros, G. S., Giannella, P. "Method Proposed for Construction of Multispan Cable-Stayed Bridges." *Journal of Construction Engineering and Management*, v. 118, June 1992, pg. 273-82
42. Dunker, Kenneth F., Rabbat, Basile. "Assessing Infrastructure Deficiencies: The Cases of Highway Bridges." *Journal of Infrastructure Systems*, v 1, n 2, June 1995, pg. 100-7
43. Dunker, Kenneth F., Rabbat, Basile. "Assessing Infrastructure Deficiencies: The Cases of Highway Bridges." *Journal of Infrastructure Systems*, v 1, n 2, June 1995, pg. 101
44. Ellis, Hugh., Jiang, Mingxiang., Corotic, Ross B. "Inspection, Maintenance, and Repair With Partial Observability." *Journal of Infrastructure Systems*, v 1, n 2, June 1995, pg. 92-99
45. Ferron, J.R. "A High Speed Data Acquisition And Processing System For Real Time Data Analysis And Control." *Review of Scientific Instruments*, v. 63, Nov. 1992, pg. 5464-8
46. Fildes, John M. "Sensor Fusion for Manufacturing." *Sensors*, v. 9, no. 1, pg. 11-19
47. Furuya, Nobuaki, Yamouka, Reizou, and Paulson, Boyd C. "Construction of Akashi-Kaikyo Bridge West Anchorage." *Journal of Structural Engineering*
48. George Hearn. "Structural Engineering Applications in Bridge Management Systems." *Restructuring America and Beyond Structures Congress, Proceedings v 1*, 1995.
49. Gerard Grippo, Bridge Inspector for A. G. Lichtenstein and Associates, Boston, MA. January 1995
50. Ghali, A., Elbadry, M., "User's Manual and Computer Program FETAB." October 1982
51. Giergiel, J., Hopster, H., Lawrence, J. M. "A Video-Based Spin-Polarized LEED Data Acquisition System." *Review of Scientific Instruments*, v. 66, June 1995, pg. 3475-9
52. Grant, Albert A. "Civil Infrastructure Systems: The Big Picture." *Journal of Infrastructure Systems*, v 1, n 2, June 1995, pg. 78-81
53. Grant, Albert A. "Civil Infrastructure Systems: The Big Picture." *Journal of Infrastructure Systems*, June 1995, pg. 78-81
54. Grivas, Dimitri A., and Shen, Yung-Ching. "Design of a Database System for Bridge Management." *Computing in Civil Engineering*, v 2, 1995
55. Grubb, Michael A., Yadlosky, John M., Herrman, Andrew W. "Behavior of Horizontally Curved Steel Highway Bridges." *Proceedings of the Symposium on Structural Engineering in Natural Hazards Mitigation, Volume II*, 1993
56. Hahin, C., South, J.M., Mohammadi, J., and Polepeddi, R.K. "Accurate and Rapid Determination of Fatigue Damage in Steel Bridges." *Journal of Structural Engineering*

57. Hamad Kashani, Florida Department of Transportation, Interview on Decemeber 1, 1995
58. Hasegawa, Kazuo., Kojima, Hiroshi., and Sasaki, Michio. "Frictional Resistance Between Cable and Saddle Equipped With Friction Plate." *Journal of Structural Engineering*, v. 121, Jan. 1995, pg. 1-14
59. Hashemian, H. M., Petersen, Kent M. "In-Situ Tests Gauge Thermocouple Performance." *InTech* v. 40, June 1993, pg. 31-33
60. Hegab, Hassan I. A. "Parametric Investigation of Cable-Stayed Bridges." *Journal of Structural Engineering*, v. 114, Aug. 1988, pg. 1917-28
61. Heywood, Peter. "Span's Unusual Design Slows Up Construction." *ENR*, v. 221, Nov. 17, 1988, pg. 22-23.
62. Hrinko, W., Miller, R., Atkan, A., Shahrooz, B., Young, C. "Instrumentation Considerations for Nondestructive and Destructive Testing of Reinforced Concrete Slab Bridges." *Proceedings of the Symposium on Structural Engineering in Natural Hazards Mitigation*, Volume II, 1993
63. Hughes, Dan. "Data Acquisition System Saves Fuel Costs, Improves Equipment Efficiency." *Pipeline and Gas Journal*, v. 222, Feb. 1995, pg. 34
64. Hutton, David V. "Dynamic Analysis of Active Control, Cable-Stayed Guideway." *Journal of Structural Engineering*, v. 119, Aug. 1993, pg. 2403-20
65. Hyman, W.A. and R. M. Alfelor and T.M. Alexander. "Field Demonstration of Advanced Data Acquisition for Maintenance Management." National Cooperative Highway Research Program, Report 361, 1993
66. James M. Pettey. "Monitoring Performance of Full Scale Structures." *Natural Hazards Mitigation*, vol 2, pg. 1596-1601
67. Jerry Potter
68. Jones, Nicolas P. and Thompson, James M. "Ambient Vibration Survey: Sunshine Skyway Bridge." *Proceedings of the Symposium on Structural Engineering in Natural Hazards Mitigation*, Volume II, 1993
69. Jotaki, Eriko., Itoh, Satoshi. "Continuous Monitoring and Data Acquisition System for Steady State Tokamak Operation." *Fusion Technology*, v. 27, March 1995, pg. 171-75
70. Juxian, Gao., Rongshang Bai., Cheng, Chemin. "Measurement of Instantaneous Temperature in Shock-Loaded Nonmetallic Solids." *Journal of Applied Physics*, v. 67, Mar. 1, 1990, pg. 2272-7
71. Kawashima, Kazuhiko., Unjoh, Shigeki., Tunomoto, Meguru. "Estimation of Damping Ratio of Cable Stayed Bridges for Seismic Design." *Journal of Structural Engineering*, v. 119, April 1993, pg. 1015-31
72. Keegan, Allen J. "How to avoid thermocouple hazards." *I & CS*, v. 65, August 1992, pg. 61-63
73. Knill, Bernie. "Getting Great Mileage From Automatic Data Collection." *Material Handling Engineering*, v. 50, May 1995, pg. ADCM 3-4
74. Krishna, P., Arya, A. S., Agrawal, T.P. "Effect of Cable Stiffness on Cable-Stayed Bridges." *Journal of Structural Engineering*, v. 111, Sept. 1985, pg. 2008-20
75. Labs, Wayne. "Data Acuisition System Provides Complete System Features With Real-Time Performance." *I&CS* v. 68, Jan. 1995, pg. 81

76. Langan, Peter E., Ironside, Donald S. "Calibration Ensures Accurate Temperature Measurement/Control." *InTech*, v. 35, Oct. 1988, pg. 61-64
77. Lauzon, Robert G., and John T. DeWolf. "Full-Scale Bridge Test to Monitor Vibrational Signatures." *Structural Engineering in Natural Hazards Mitigation*, v 2, 1993, pg. 1089-94
78. Lewis, Clifford W. "Is Your Temperature Data Good Enough?" *InTech* v. 41 (Jan. 1994, pg. 34-37
79. Madanat, Samar., Michalani, Rabi., Wan Ibrahim, Wan Hashim. "Estimation of Infrastructure Transition Probabilities from Condition Rating Data." *Journal of Infrastructure Systems*, v 1, n 2, June 1995, pg. 120-125
80. Markow, Michael J., "Highway Management Systems: State of the Art." *Journal of Infrastructure Systems*. September 1995
81. Markow, Michael. "Highway Management System: State of the Art." *Journal of Infrastructure Systems*, v 1, n 3, Sept. 1995, pg. 186-191
82. Matteo, John., Deodatis, George., and Billington, David P. "Safety Analysis of Suspension-Bridge Cables: Williamsburg Bridge." *Journal of Structural Engineering*, v. 120, Nov. 1994, pg. 3197-211.
83. Menn, C., *Prestressed Concrete Bridges*, Birkhauser Verlag AG Basel, Germany, 1990.
84. Morse, Dan. "A New Lake and a Beautiful Bridge." *Civil Engineering*. v. 58, July 1988, pg. 42-45
85. Narendran, Nadarajah., Weiss, Joe. "High Temperature Fiber-Optic Strain and Temperature Sensor for Structure Health Monitoring." *Instrumentation, Control, and Automation in the Power Industry, Proceedings*, v. 38, 1995, pg. 273-282
86. NCHRP. "Field Demonstrations of Advanced Data Acquisition Technology for Maintenance Management." National Cooperative Highway Research Program, Report 361, 1993
87. Newell, Vann A., Tanner, David T., and Wagner, Charles D. "Checking Concrete Growth." *Civil Engineering*, January 1994
88. Normile, Dennis. "Investigators Probe Haengju Failure." *ENR*, v. 229, Aug. 17, 1992, pg. 9
89. Nowak, Andrzej S., Nassif, Hani, and Frank, Karl H. "Fatigue Load Spectra for a Steel Girder Bridge." *Transportation Research Record 1393*
90. Pettey, James M. "Monitoring Performance of Full Scale Structures." *Proceedings of the Symposium on Structural Engineering in Natural Hazards Mitigation*, Volume II, 1993
91. Potter, David. "Signal Conditioners Expand DAQ System Capabilities." *I &CS*, v. 68, Aug. 1995, pg. 25-6
92. Price, Ken D. "Economical Steel Box Girder Bridges." *Transportation Research Record 1393*
93. Rada, Gonzolo R., Aramis Lopez, Gary Elkins, Cheryl Richter, and Brandt Henderson. "Long-Term Pavement Performance Program: Instrumentation Selection and Installation." *Transportation Research Record*. n 1432, 1994, pg. 32-43

94. Reich, Yoram., Fenves, Steven J. "System That Learns to Design Cable-Stayed Bridges." *Journal of Structural Engineering*, v. 121, July 1995, pg. 1090-100
95. Reina, Peter. "Simplicity is Motivated by Bridge Privatization." *ENR* v. 226, Feb. 11, 1991, pg. 23-4
96. Reina, Peter. "Up and Away to a World Record." *Engineering News Record*, v. 233, Sept. 19, 1994, pg. 76-8
97. Richard Semple, Florida Department of Transportation, Interview on Decemeber 1, 1995
98. Riviere, Jean-Michel., Luttenbacher, Damien., Robert., Michel., Jouannet, Jean-Pierre. "Design of Smart Sensors: Towards an Integration of Design Tools." *Sensors and Actuators*, v. 47 no. 1-3, Mar/Apr. 1995, pg. 509-515.
99. Robison, Rita. "Cable Stays Catch On." *Civil Engineering*, v. 56, June 1986, pg. 58-61
100. Rowings, James E., Kaspar, Steven L. "Constructability of Cable-Stayed Bridges." *Journal of Construction Engineering and Management*, v. 117, June 1991, pg. 259-78
101. Saberi, Marc. "Monitor Thermocouples Electronically." *EDN*, v. 30, Oct. 17, 1985, pg. 175
102. Sarkar, Partha., Jones, Nicholas P., Scanlan, Robert H. "Identification of Aeroelastic Parameters of Flexible Bridges." *Journal of Engineering Mechanics*, v. 120, Aug. 1994, pg. 1718-42
103. Scordelis, AC., Bouwkamp, JG., Wasti, ST., Anicic, D. "Structural Behavior of a Skew Two Span Reinforced Box Girder Bridge Model, Vol. III-Response During Ultimate Loading Behavior." FHWA-RD-80-S01195, 1980
104. Seif, S. P., Dilger, W.H. "Nonlinear Analysis and Collapse Load of P/C Cable Stayed Bridges." *Journal of Structural Engineering*, v. 116, March 1990, pg. 829-49
105. Setzer, Steven W. "Bridge Mixes Old and New." *Engineering News-Record*, v. 216, June 19, 1986 pg. 41-2
106. Shahawy, Mohsen. "Comparison of the Analytical and Measured Time-Dependent Strains in the Pylons of the Sunshine Skyway Bridge." Research Report SRR 2-92, Florida Department of Transportation, January 1992
107. Shahawy, Mohsen. "Comparison of the Analytical and Measured Time-Dependent Strains in the Segments of the Sunshine Skyway Bridge." Research Report SRR 3-92, Florida Department of Transportation, February 1992
108. Shaland, Alex. "How to Select a Thermocouple." *Machine Design*, v. 62, Feb. 22, 1990, pg. 50
109. Shawawy, Mohsen. "Field Instrumentation to Study the Time Dependent Behavior in the Sunshine Skyway Bridge." Research Report No. SRR 01-92, Florida Department of Transportation, January 1992. pg. 10
110. Shen, T.H., D.H. Libby, and J.F. Abel. "User's Manual for GISMA, Graphical Interactive Structural Matrix Analysis." Cornell University, Ithaca, N.Y., October 1987

111. Shiu, Kwok-Nam and Henry G. Russell. "Effects of Time- Dependent Concrete Properties on Prestress Losses." *Canadian Journal of Civil Engineering*, vol 14, 1987, pg 649-654.
112. Shiu, Kwok-Nam and Russell, Henry G. "Effects of Time Dependent Concrete Properties on Prestress Losses." *Canadian Journal of Structural Engineering*, v 4, 1987.
113. Smith, Jon. "Matching Temperature Sensors With Process Tasks." *I & CS*, v.67, April 1994, pg. 77-82
114. Smithline, Herb. "Practical Guidelines for Temperature Measurement." *Chemical Engineering*, v. 100, Dec. 1993, pg. 78-81
115. Soast, Allen. "Skyway Bridge Boasts a Record and Innovations." *Engineering News-Record*, v. 217, Sept. 11, 1986, pg. 20-22
116. Soast, Allen. "Stayed Girder Reaches a Record With Simplicity." *Engineering News-Record*, v. 216, May 22, 1986, pg. 26-28
117. Stephenson, D. A. "Tool-work Thermocouple Temperature Measurements-- Theory and Implementation Issues." *Journal of Engineering for Industry*, v. 115, Nov. 1993, pg. 432-7
118. Strassberg, Dan. "System Integrates All Phases of Data Acquisition." *EDN*, v. 40, Jan. 5, 1995, pg. 23
119. Sunshine Skyway Bridge, Drawings and Specifications, by Figg and Muller Engineers Inc. 1982, 1-369
120. Tang jhy-Pyng, Leu, Ker- Ming. "Vibration Measurement and Safety Assessment of Bridges." *Chung-kuo Kung Ch'eng Heuch K'an/Journal of the Chinese Institute of Engineers*, v11 n 5, Sept. 1988.
121. Tang, Jhy-Ping., and Ker-Ming Leu. "Vibration Measurement and Safety Assessment of Bridges." *Journal of the Chinese Institute of Engineers*, vol. 11, no 5, pg. 543-549
122. Terpening, Thomas B., Irwin, Michael. "Out With the Old." *Civil Engineering*, v. 62, Sept. 1992, pg. 50-53
123. Terry J. Wipf. "Use of Tilt Sensing Equipment for Monitoring Long-Term Bridge Movement." *Canadian Journal of Civil Engineering*. vol 18, 1991, pg. 1033-1046
124. Theisen, John P. "Thermocouples Stage a Comeback in Forehearth Instrumentation." *Glass Industry*, v. 68, Oct. 10, 1987, pg. 18-20
125. Ton-Lo., Huang, Dongzhou. "Cable Stayed Bridge Vibration Due to Road Surface Roughness." *Journal of Structural Engineering*, v. 118, May 1992, pg. 1354-74
126. Vogel, Robert. "Teamwork Produces Improved Monitoring System." *InTech*, v. 41, Oct., 1994, pg. 46-9
127. Wang, T.P. "Thermocouple Selection and Maintenance." *InTech*, v. 38, April 1991, pg. 44-6
128. Wipf, Terry J. "Use of Tilt Sensing Equipment for Monitoring Long-Term Bridge Movement." *Canadian Journal of Structural Engineering*, v 18, 1991.
129. Yanev, B.S. "Bridge Management: A Panel Discussion." pg. 666-667
130. Yanev, B.S. "Bridge Management: A Panel Discussion." *Restructuring America and Beyond Structures Congress*, Proceedings v 1, 1995, pg. 666-667

131. Yanov, B.S. "Bridge Management: A Panel Discussion." *Restructuring America and Beyond Structures Congress, Proceedings v 1, 1995*, pg. 666-667
132. Yen, W-H., Baber T. T., Barton F. W. "Ambient Vibration Response of a Long Span Bridge." *Proceedings of the Symposium on Structural Engineering in Natural Hazards Mitigation, Volume II, 1993*
133. Zalik, Alexa. "Networked System Captures Data and Dollars." *Controls and Systems*, v. 39, Sept. 1992