

**GENERATIVE OPPONENTS: A NEW ARCHITECTURE FOR
NATIVE SOIL**

by

Axel Gabriel Paredes

M.A. (Distinction), Architectural Association of London - AA

M.T.A. Madrid School of Architecture - ETSAM

B.Sc.Arch, University of Utah

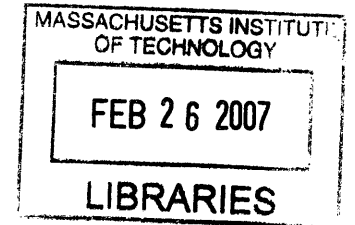

Submitted to the department of architecture in partial fulfillment for the degree of

MASTER OF ARCHITECTURE

at the

MASSACHUSETTS INSTITUTE OF TECHNOLOGY

ROTCH

February 2007

© 2007 Axel Paredes. All rights reserved.

The Author hereby grants MIT permission to reproduce and to distribute publicly paper and electronic copies of this thesis document in whole or in part in any medium now known or hereafter created.

Signature of Author:

Department of Architecture

January 18, 2007

Certified by:

Yung Ho Chang

Professor of Architecture

Thesis Supervisor

Accepted by:

Yung Ho Chang

Professor of Architecture and Head of the Department

Chairman, Committee for Graduate Students

John Fernandez

Associate Professor of Architecture and Building Technology
Reader

Axel Kilian

Postdoctoral Associate in the Computation Group
Department of Architecture
Reader

GENERATIVE OPPONENTS: A NEW ARCHITECTURE FOR NATIVE SOIL

by

Axel Gabriel Paredes

Submitted to the Department of Architecture on January 18, 2007 in Partial Fulfillment of the Requirements for the Degree of Master of Architecture

ABSTRACT

A design of an Ecological Visitor Center for the Central American country of Guatemala was carried out based on a series of explorations with analogue and digital design techniques. The theses addresses a possibility of how traditional methods of design and construction can be employed in conjunction with digital design strategies, in order to develop a new kind of architecture in the natural ravines that form part of the city's fabric.

The architecture of the project explores a possible use in the utilization of locally available materials in design, both natural and industrial, suggesting innovative architectural possibilities beyond the handcrafted vernacular language of conventional practice and the synthetic perfection of contemporary digital design. Using bamboo as the main construction material, the building was designed from a series of studies that were developed to solve the building's complex geometry with locally available methods.

Thesis Advisor: Yung Ho Chang
Professor of Architecture
Head of the Department of Architecture, MIT

ACKNOWLEDGMENTS

I would like to dedicate this thesis to my parents, Olga de Paredes and Ruben Paredes, and my family. I am very grateful to my Thesis Advisor, Yung Ho Chang, for his insightful advice, enthusiasm and encouragement. Thanks to John Fernandez for his helpful comments and feedback on my work. I would like to thank Axel Kilian for his commitment, advice and constant help throughout my thesis. Thanks to Nancy Jones, Cynthia Stewart and the MIT Department of Architecture for their support and for assisting me in so many different ways. I would also like to thank my professors, whose invaluable teachings, commitment and enthusiasm made it a stimulating experience throughout my studies at MIT. And an exceptional thank you to Ana Alemán, for her company, presence, advice, help and patience with me and the very late hours throughout the dissertation process, which helped make the completion of this thesis possible.

Axel Paredes

BIOGRAPHY

Axel Paredes was born in Guatemala City. Before coming to MIT, he received a Master of Arts degree with Distinction in the field of Theory and History of Architecture from the Architectural Association of London (AA), a Master of Architecture Technology from The Madrid School of Architecture (ETSAM), and an Undergraduate degree in Architecture from the University of Utah. Before teaching architecture design studios at the TEC de Monterrey in Mexico City from 2002 to 2003, he taught at UFM in Guatemala City, where he created the PF(lab), a design studio laboratory for experimental projects in Central America, such as the proposal for Guatemala City's underground transportation system. He has co-taught architecture design workshops in Guatemala with invited teachers from MIT and the AA, and has lectured in Costa Rica, Panama and Mexico.

INDEX

1. Introduction	13
2. Urban Burrows	19
3. Topographic Looms	32
4. Woven Fabrics	47
5. Ramifications	60
6. Fitted Seams	87
7. Skin and Stem Structure	91
8. Conclusion	111
9. <i>Source of Illustrations</i>	112
10. <i>Works Cited</i>	113
11. <i>Bibliography</i>	114

Generative Opponents

A NEW ARCHITECTURE FOR NATIVE SOIL



Left: Montage by author using an image of Laugier's Primitive Hut by Charles Eisen (1720-1778). Source of original: <http://www.usc.edu/dept/architecture/slide/ghirardo/CD2.html>

1. INTRODUCTION

New and smart materials in contemporary architecture and the product-design industry have been developed in great part due to the research in synthetic materials such as plastics and high-tech ceramics. Their application in these areas in combination with new digital fabrication techniques and computational design processes, have also generated new architectural languages that reflect these technological advances. These new manufacturing techniques make possible the complex geometry generated by computational exploration in such a precise way that building components are assembled seamlessly to produce a technical artifact of synthetic perfection, continuing the modernist tradition of technological optimism.

Such interest for the new in architectural design is not exclusive of industrialized cultures, but is also evident in developing countries. In an attempt to achieve an image of sophistication and participation in the productive world of industry and economic powers, a variety of modern architecture examples, although in some cases lacking such “precision” due to the locally available technology, emerge in their largest cities as symbols of progress and development. In this context, the issue of the vernacular versus the modern, and technology versus nature, is therefore more problematic in a developing country that aims to acquire the status and lifestyle of an industrialized society, and which seems to long for the image of an independently capable economy that, in order to be considered as such by the rest of the international community, tends to want to shed

its traditional image. In fact, it can be suggested that “in the developing world, as long as cultural identity and variety are identified with the pre-modern, and the pre-modern with inferiority, deprivation or sentimentality, then the championing of a differentiation based on the traditional vernacular remains problematic, whatever its environmental, social or economic advantages” (Hagan, p. xvi).

On the other hand, the tourist industry of these countries, which in many cases is their largest economic source of income, depends on the opposite condition: the conservation of traditional culture as is reflected in the natural landscapes and vernacular architecture becoming major attractions for outside visitors. This has led to the notion of the existence of a romantic rural life of natural sights and nostalgic low-tech buildings that reflect a “simple” way of living of past times and, in some cases, even before “western civilization” conquered and technologically invaded the so-called vernacular “identity”. In many Latin American countries, polarities like these are present everywhere: from the ambitious embracing of technology by the urban dweller, to its hesitant resistance by many of the indigenous inhabitants.

In architecture and the construction industry this constant oppositional way of thinking has led to the illusion that “contemporary” exploration in architecture can mainly be produced with the aid of digital techniques, and constructed almost exclusively with technologically produced materials. While traditional architecture in natural environments, on the other hand, is assumed and encouraged to continue uncritically in the safe path of conservative typologies that seem to be best suited to be built with traditional design and construction techniques. A further assumption is that local materials and techniques can only produce traditional architecture due to its basic limitations, while high-tech methods will produce mainly high-tech buildings. Nevertheless, it is because of these assumptions that traditional methods of construction tend to stay unchanged, as they are left out of the exclusive niche of contemporary architecture and design experimentation. As a result, local materials, hand-craft methods, and simple construction techniques, as



Images 1-3. Top: Public telephone in Bolivia, below: urban life in Guatemala. Right: Church in San Andres Xecul, Guatemala



they are relegated almost exclusively to the production of traditional architecture, are not explored beyond what they are known to produce in the first place. At best, one tends to relate these techniques to what is conventionally known as the “real” traditional architecture of these countries, in contrast to the well known mass-produced traditional decorative building elements ubiquitous in the post-modern movement.

But does this mean that nature ends with technology? That their apparent incompatibility in their existence reinforces their opposition while making more obvious the separation between urban and rural, center and periphery, city and nature, indigenous culture and western technology? If these contrasts between technology and nature have constantly been evolving within these cultures and have, in fact, formed part of their history for centuries, it can be said that these oppositions are not mutually exclusive nor negative, but in fact tend to co-exist productively as (a)part of each other. In this context, can traditional building techniques still be employed today in order to produce an-*other* architecture, one that goes beyond vernacular languages for touristic attractions? Can today’s architectural exploration include a wider variety of techniques beyond the exclusively digital and high-tech materials that have contributed to its synthetic perfection? The use of local materials, digital and analogue techniques, and low-tech and high-tech manufacturing, can be employed not only as opposite techniques for opposite purposes, but they could also be employed in a fluid design and construction process for different design purposes. In developing countries both techniques are increasingly available as more and more digital technologies, specially computational tools, software, and training, become available commercially.

Indeed such hybrid type of exploration could work as a generative process that can contribute to the contemporary discourse of architecture. The characteristic “imperfection” and redundancy of local materials and techniques, in combination with digital design and experimentation, can generate an architecture that goes beyond the synthetic artificiality of present architecture, and has the potential

to produce new formal and aesthetic possibilities for design. This is also an economic advantage for these countries, where local techniques and materials are easily available and at lower costs than the current imported materials. Such an architecture is able to emerge beyond the conventional oppositions of the vernacular and the modern, the conservative and the avant-garde, and the rural and industrial. In fact it can be said that the oppositional dialectic between the natural and the artificial is not necessarily so obvious anymore, as the boundary that has traditionally separated them becomes more problematic. "To take an example, a computer, because of its materials and complexity, is in many ways more artificial than, let's say, a wooden table. But in a world in which the notion of information is omnipresent, a computer structure has certainly more to do with nature than the wooden table" (Picon, p. 324). The relationship of architecture to nature then needs to be re-examined away from the two conventional extremes that sees rural nature as either something to be respected and untouched, or nature as something that inevitably has to be transformed in order to accommodate technology. In this context, Hagan describes that architects involved in these two extremes seem to base their arguments in anachronistic models: "in the case of the arcadians, of nature as something animate and powerful, which is to be respected; in the case of the rationalists, of something susceptible to empirical measurement..." (p. xvi).

In this thesis such issues are addressed through the design of an Ecological Visitor Center in Guatemala City, where the source of many natural and basic industrial materials are already available. The site location for such an institution in Guatemala City is focused in the natural landscapes that form part of Guatemala City's urban fabric, which mainly consist of undeveloped natural ravines working as entangled ecological corridors filled with thick vegetation that flow like green paths through the concrete strata of the capital city. In such a context, how can an organic yet technological 'machine' emerge from these seemingly opposing concepts while also manage to inhabit these urban burrows? The proposed architecture of this kind of programmatic and contextual conditions will not reflect these changes in a type of post-modern semiotics of either natural or vernacular vocabulary;

nor will it remain an uncritical continuation of the functional inheritance of extreme technocratic rationalization. Instead, the architecture for this project uses the natural site to generate creative processes and tectonic innovations with technology; and technologically use nature to allow for creative emergence. Its architecture is not one that nostalgically calls for a return to a vernacular past that responds more “naturally” to the environment and the site; but neither is it a new kind of environmentally re-conditioned modernism that uses, at best, new building technology and simple strategies to be checked in a list that certifies its environmental value for commercial purposes, in the same way that a credit card receives a silver, gold, or platinum credit line. Nevertheless, the building of an Ecological Visitor’s Center of this kind is important for a country where the sustainable use of its natural resources is an essential aspect of its main economic industry of agricultural production and tourism. The architecture of the project will therefore explore a possible increase in the utilization of locally available materials, both natural and industrial, in the design of this facility in order to suggest innovative architectural possibilities beyond the handcrafted vernacular language of its conventional practice.



Illegal settlements in ravines in Guatemala City. 2006

2. URBAN BURROWS

Taking Guatemala City's green urban corridors of the ravines as possible sites for an architectural intervention means to work with two already "opposing" contexts: on the one hand technology as embodied by the modernization of urban buildings and infrastructure (as well as its polluting effects); and on the other the natural ravines that bifurcate as natural extensions of the Mayan rainforests of the immediate surroundings, which introduce themselves uninterrupted throughout the whole city. These drastic contrasts of texture and material were not planned as parks in urban landscapes, and in consequence were not integrated to the ubiquitous colonial grid of Latin American cities. Nevertheless they seem to form a pattern of planned and calculated urban patches that are woven together by a system of organic seams in precise geographic locations, both resisting as well as allowing urban expansion: always inhabiting the highest or lowest points of the topography, and defining a systematic organization of artificial urban crops to "take place", as soon as the natural topographic curvature begins to transform into a flat condition of populated attractors in a stable state of urban expansion.

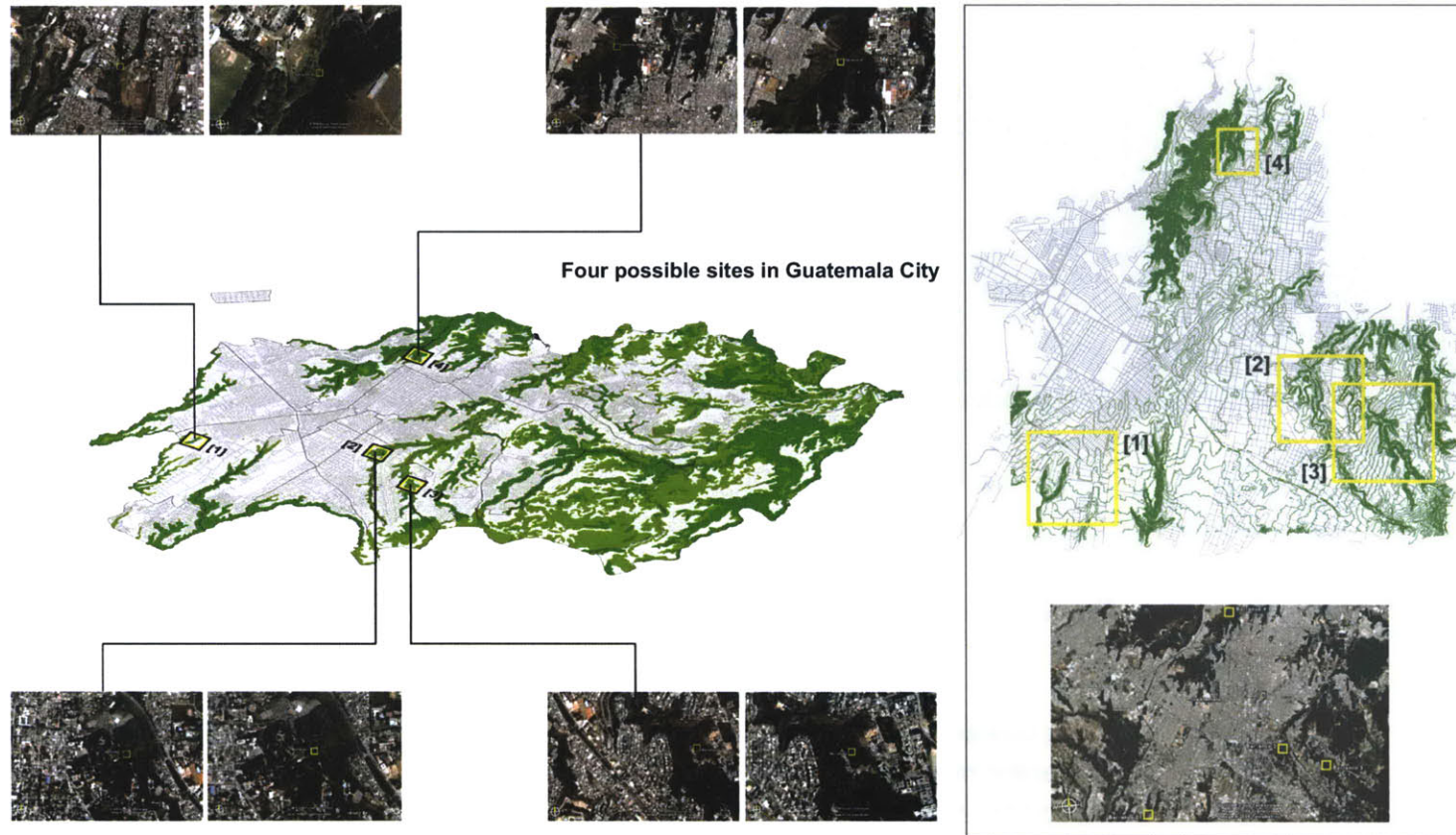

Four possible sites in Guatemala City

Guatemala City is subdivided in numbered postal zip codes called “zones”. Within these urban zones, four possible sites were preliminarily chosen for different reasons: their proximities to different urban densities, capacity to connect various urban patches, variable depth in their topographic condition, and their immediacy to the four major universities of the city and other public and private schools. This last factor was a primary incentive due to the educational program for the project, which could rely on the nearby infrastructure to form a campus-like system of research facilities and exhibitions of the natural surroundings. A major ravine roughly running north to south that separates the largest public University of San Carlos with the residential, commercial and

20

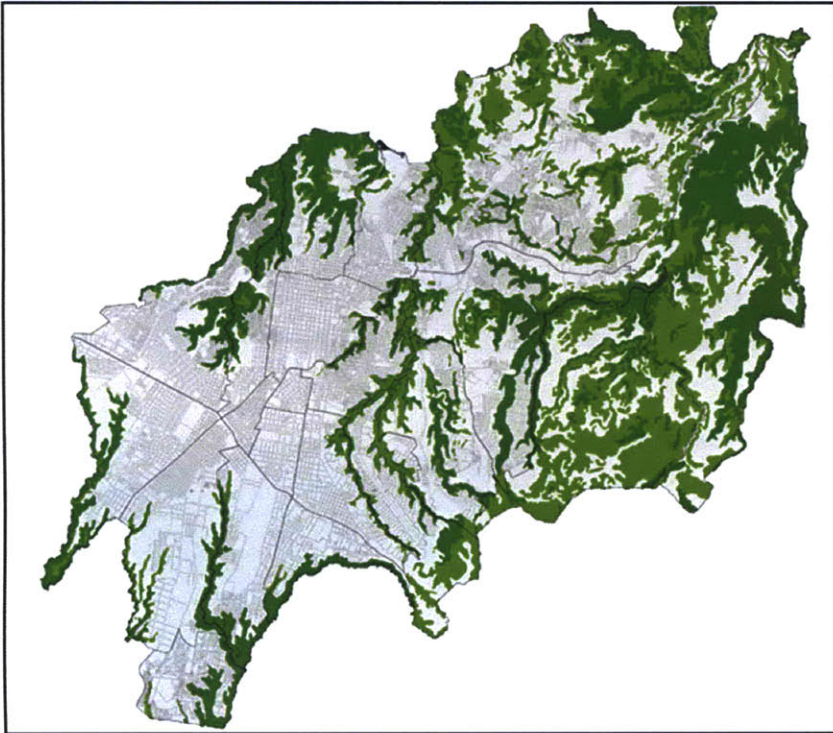

Sito 1 San Carlos

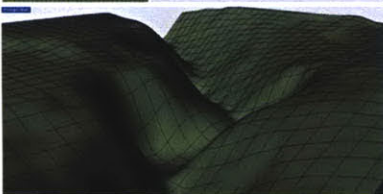
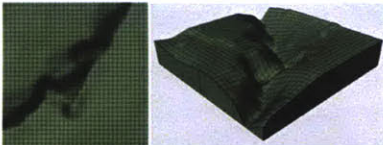

Sito 4 Del Valle

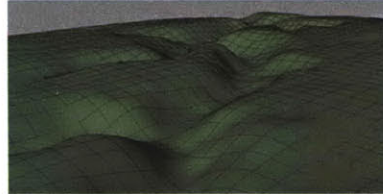
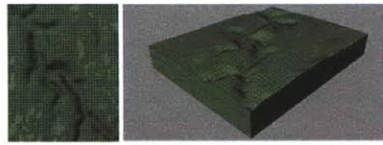

Sito 2 Mariano Galvez

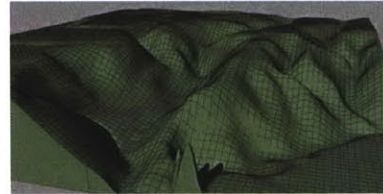
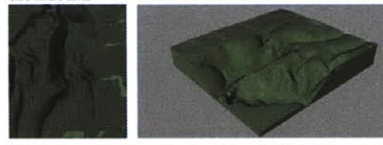

Sito 3 Marroquin

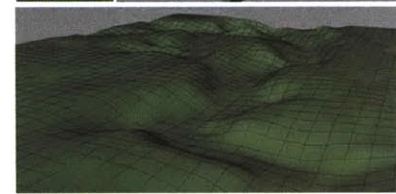
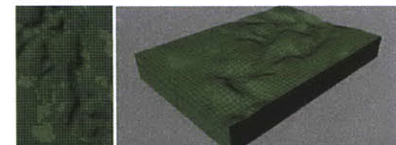

Digital models of the four sites

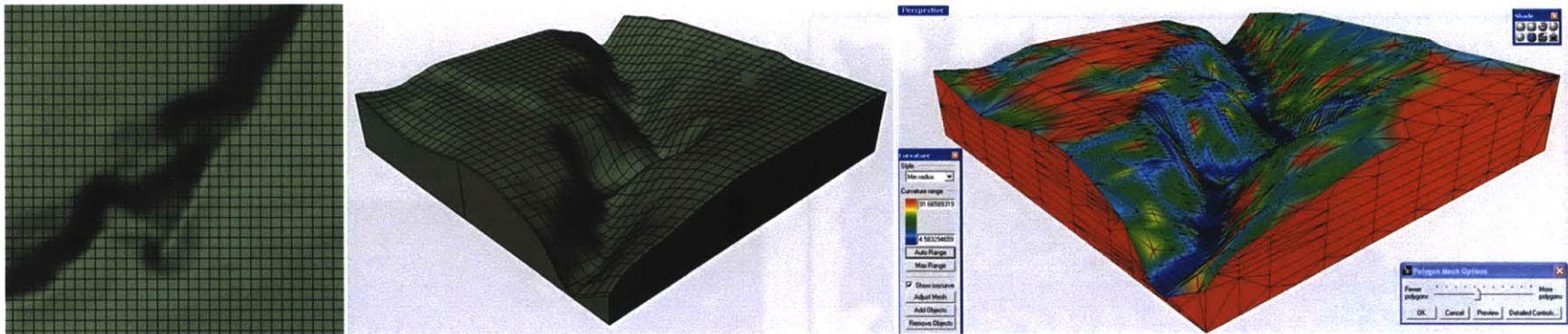

Sito 1: San Carlos

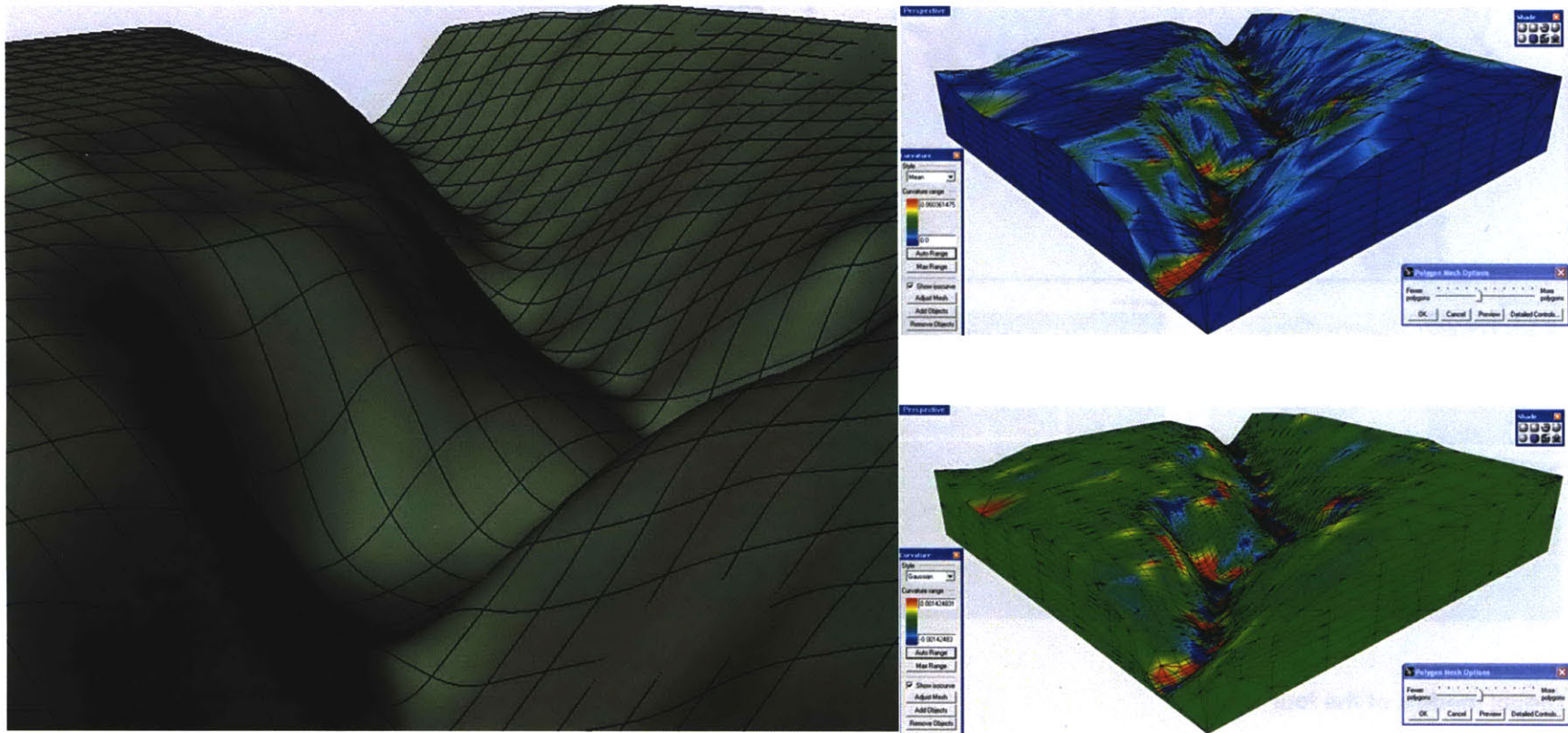

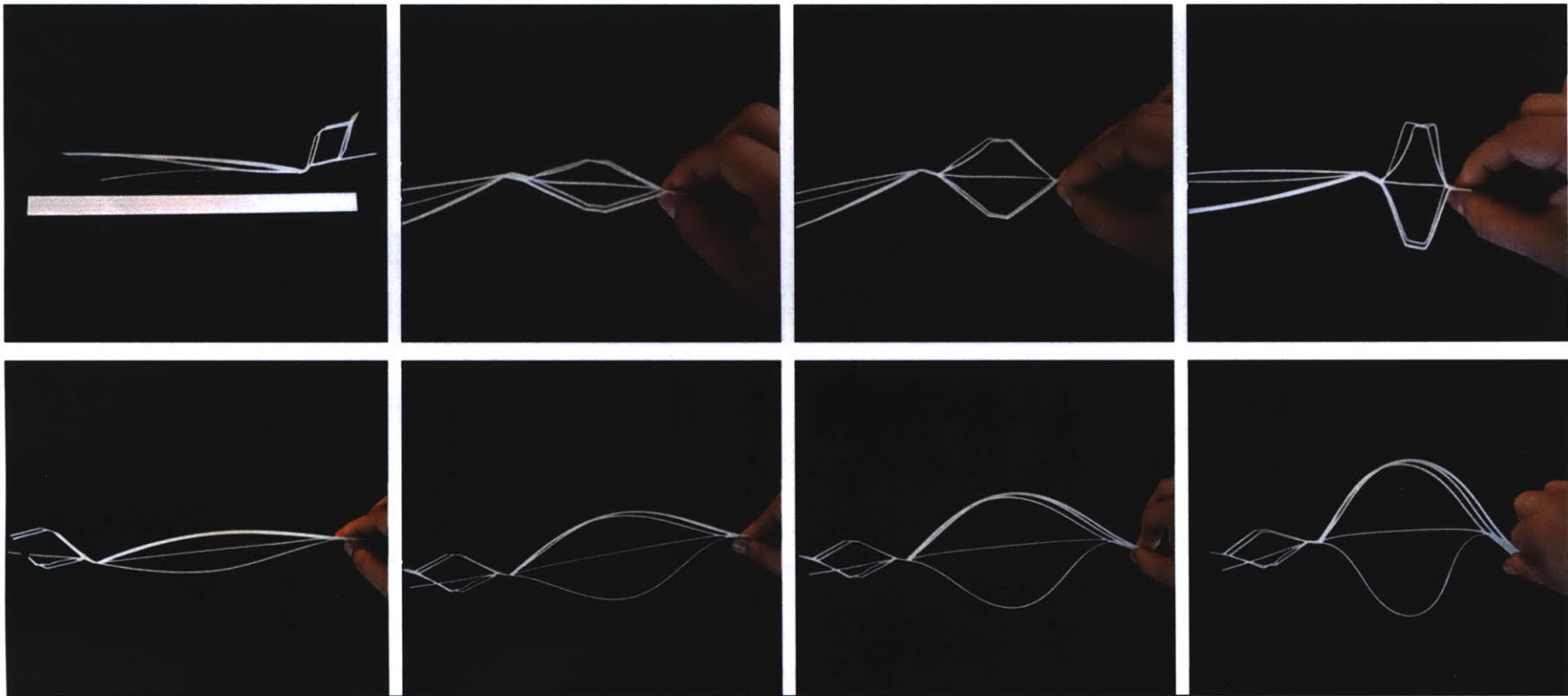

Left: Surface analysis of the site of 'San Carlos'. Right: Strips of paper model of site as it is adjusted to different height conditions

industrial areas of “zone 12” was chosen for the site of the project. Its proximity to the new and first *Transmetro* line, a surface bus system that will function as the main public transportation, is also an advantage to the site which will allow visitors to reach the ravine from different parts of the city.

The complex topographic surface condition of the ravine in the site was first analyzed to understand its topological condition and variation. In order to explore a possible tectonic system for the project, the site was first modeled digitally to generate different surface analysis, and then an abstracted paper model was developed to understand its topological system. To achieve this, a series of paper strips were scored, cut, folded and assembled in sections throughout the site so that the same strip of paper, when conditioned to different parameters in the cuts and scoring of the strip, would recondition itself to the topographic variation. The height of the sectional strip is achieved by pulling

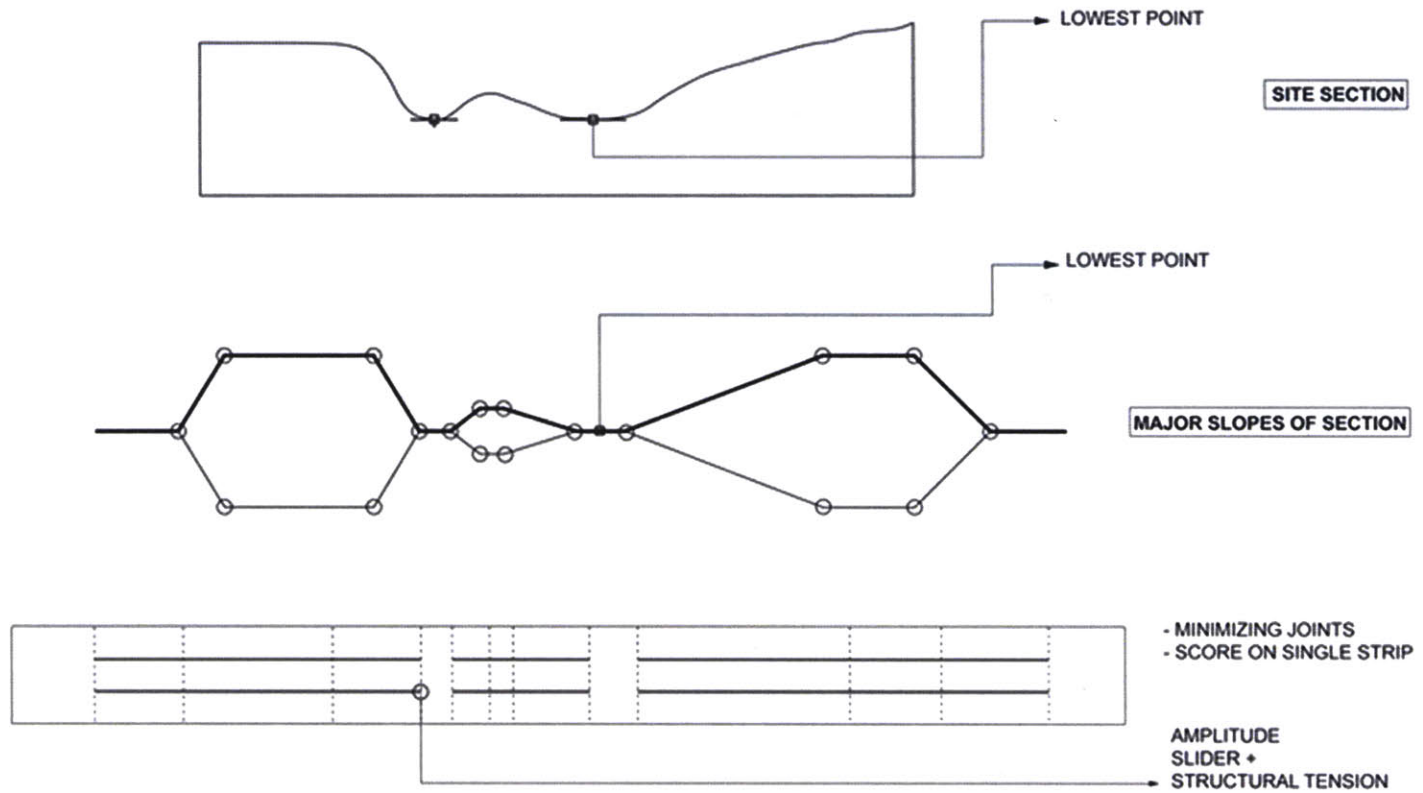
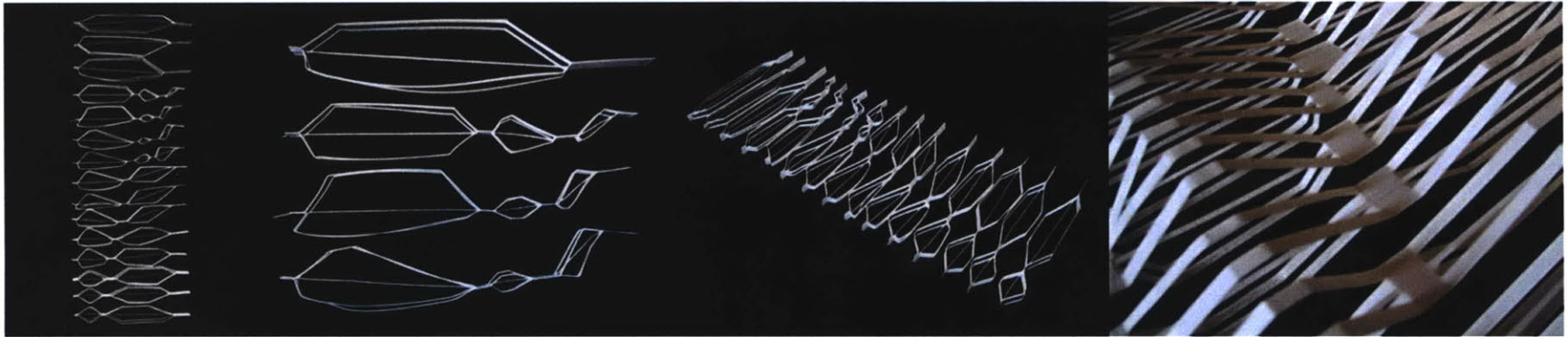

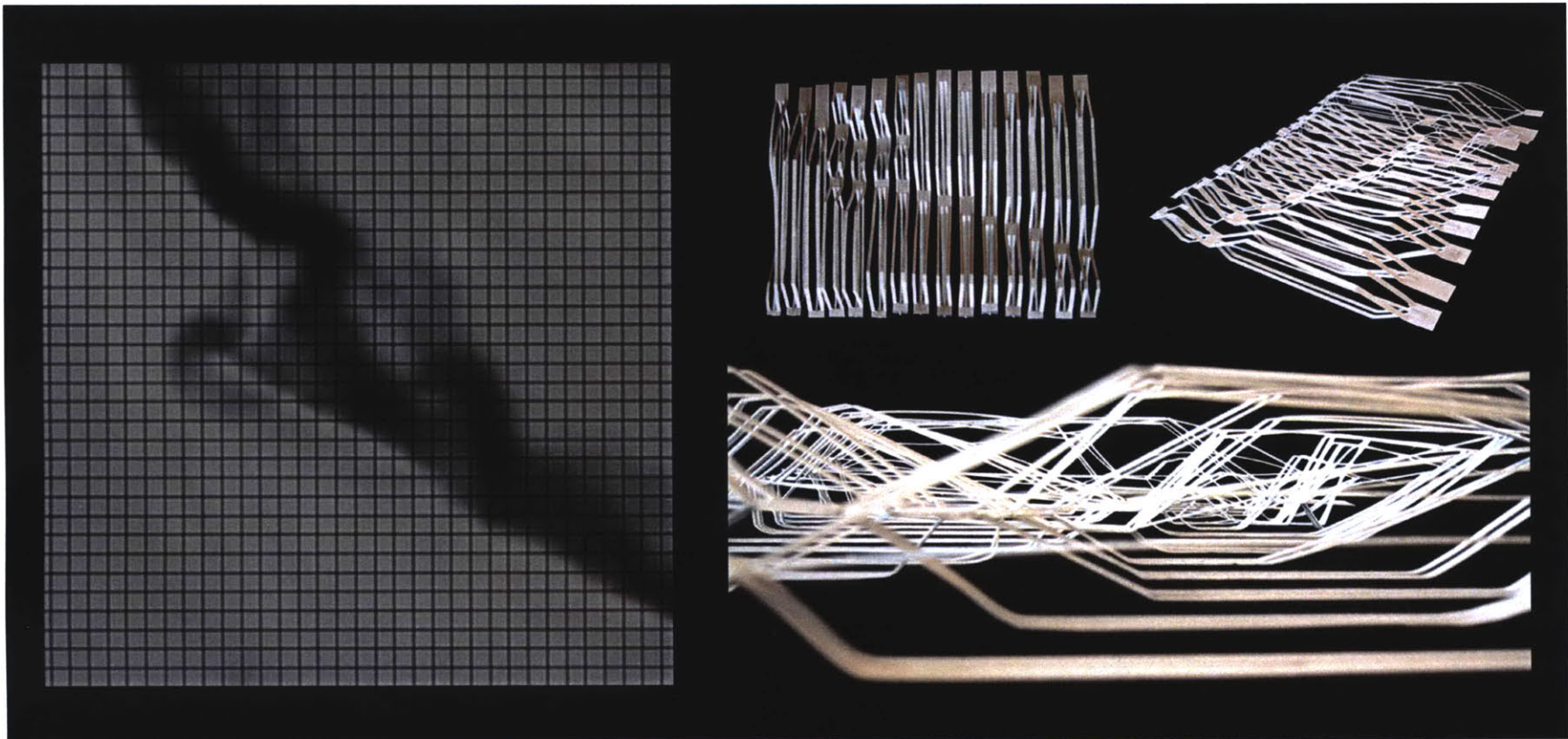

Left and right: Physical and digital models of site. The paper model shows the topographic variation of the site and the diagram indicated the system devised for the model.

on the middle strips as a bow in tension, while the length of the different curvatures are dictated by the length of the cuts and its subsequent variation in the scoring and folding. This model suggested that the continuous variation of the slope of the ravine at a certain height along the site would need a bridge-like system of decks that could be used for programmatic distribution. At the same time they could work continuously and independently from the complexity of the ravine's geometry. On the other hand, an independent system of bridges will need only a few specifically located and integrated vertical structural cores as its supports as a part of the same structural network, without the need to intervene directly on large areas of the slope of the ravine.







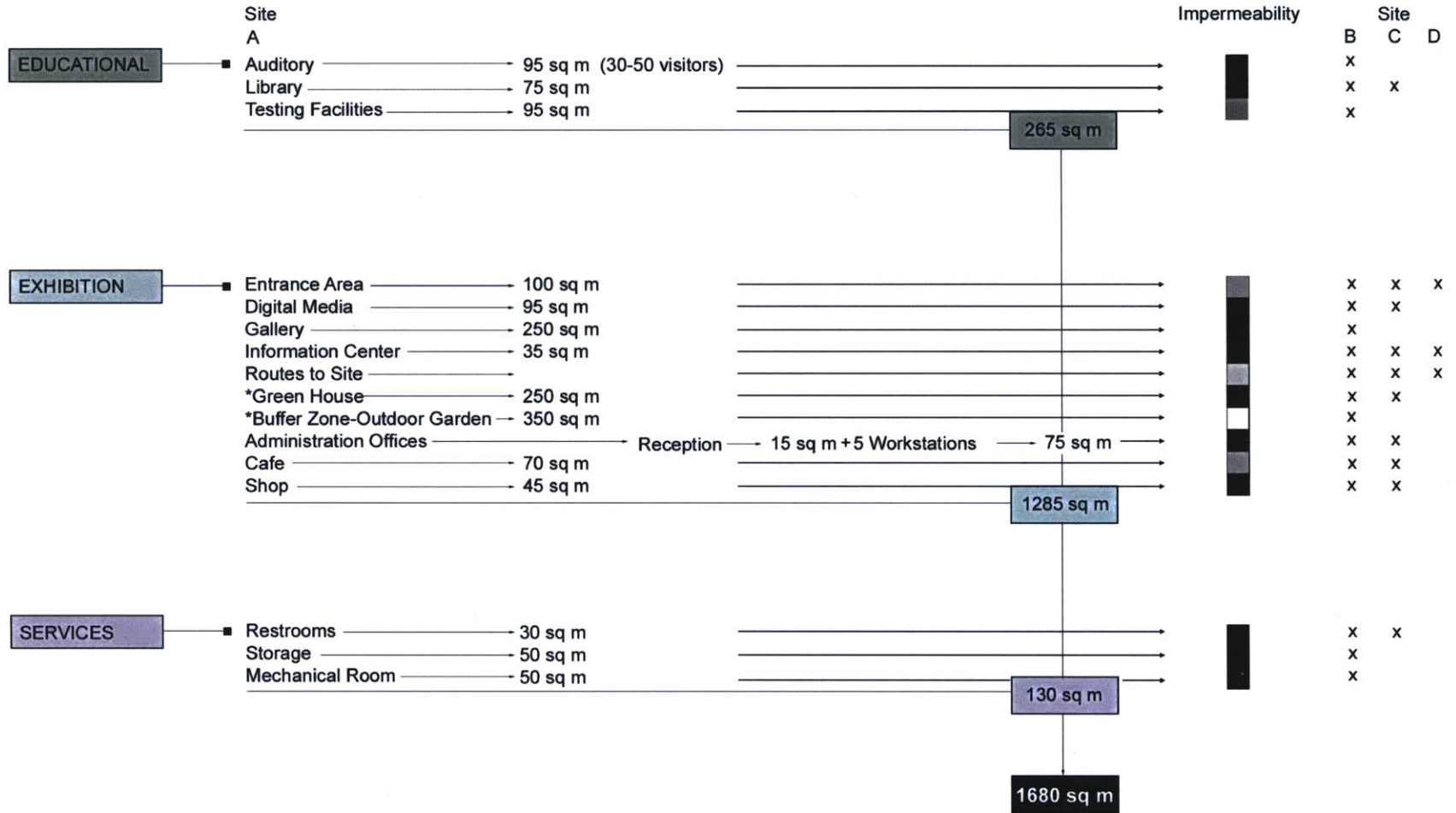























Image 4 and 5. Top: Road in a ravine in La Paz, Bolivia. Right: Market in Almolonga, Guatemala.





The program for the project was developed in relation to much needed local educational infrastructure for the awareness of nature, as well as for outside visitors. A series of different exhibition areas, multi-media galleries, library, information centers and cafes form a system of attractions for both educational and recreational purposes. The easy access to public facilities will allow the use of the center and its surroundings as an urban natural park, urgently needed in this city that lacks accessible outdoor public urban parks for recreation.

	PROGRAM AREA		IMPERMEABILITY
EDUCATIONAL		auditory 12 x 8 = 96	
		library 6 x 12 = 72	
		test facilities 12 x 8 = 96	
EXHIBITION		entrance area 14 x 7 = 98	
		digital media 15 x 6 = 90	
		gallery 16 x 16 = 256	
		Information ctr 7 x 5 = 35	
		green house 22 x 11 = 242	
		admin 7 x 11 = 77	
		cafe 14 x 5 = 70	
		shop 9 x 5 = 45	
SERVICES		wc 7 x 4 = 28	
		storage 10 x 5 = 50	
		mechanical 10 x 5 = 50	



Top and Right: Programme for the Ecological Visitor Center and its permeability requirements of each area.

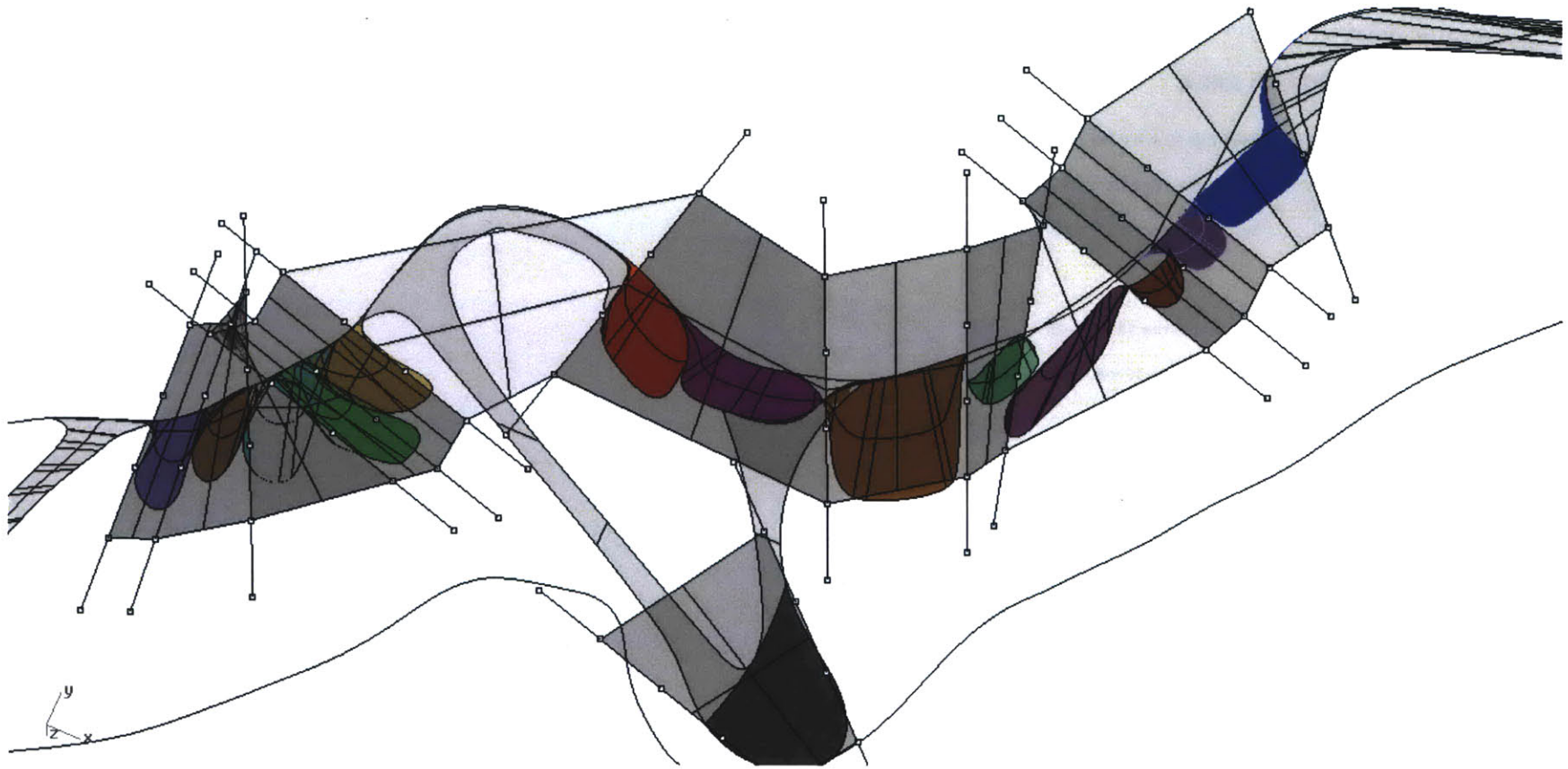

Imae 6. Right: Young man gathers fruit in a rain forest of Ecuador, blending with the vegetation. Top: Opacity requirements for the program on the site.



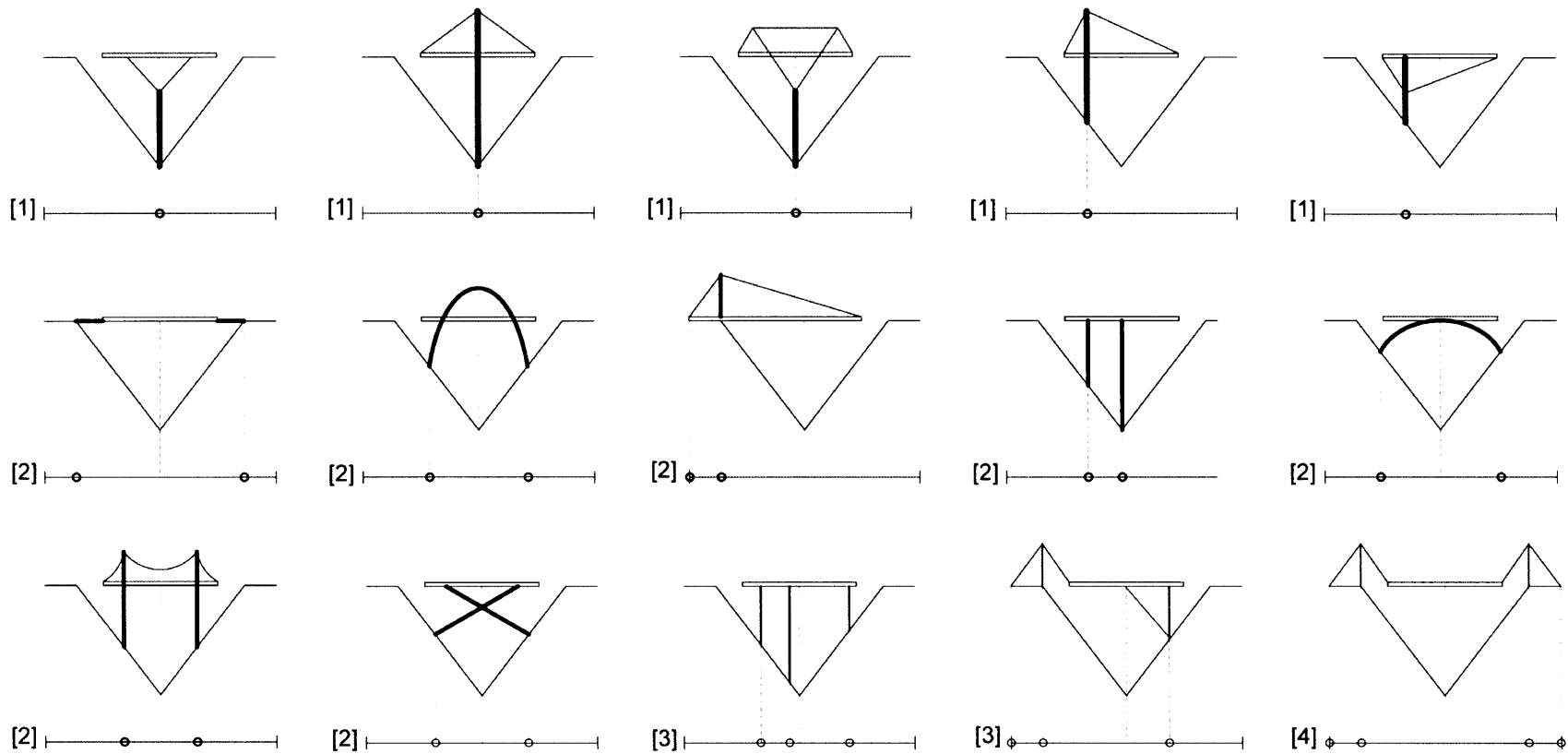

3. TOPOGRAPHIC LOOMS

In order to develop a series of programmatic bridges from the geometry of the site so that the general typology of the building could accommodate itself in parallel to the continuous slope variation, a catalogue of different anchoring systems was developed. By keeping a minimum number of structural cores throughout the site, the catalogue study was based on a series of possible anchoring points to connect

Left: Catalogue of anchoring points. Right: Analysis of topographic normals and sectional curvature change

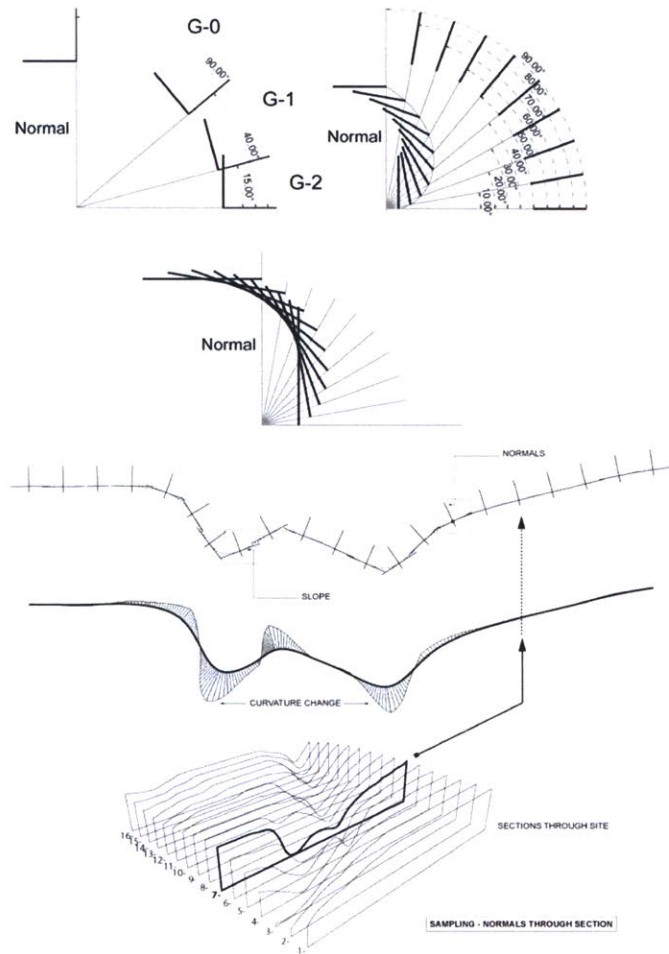

two edges on opposite sides, ranging from 1 to 4 basic anchoring points as seen in elevation, in combination with different structural configurations. In order to generate the different anchoring points and their main axes as initial guidelines for the design of the building, the site was subdivided in orthogonal sections. A system of surface normals was then derived and populated along the site. This began to indicate the basic geometric configurations for the vertical supports, while

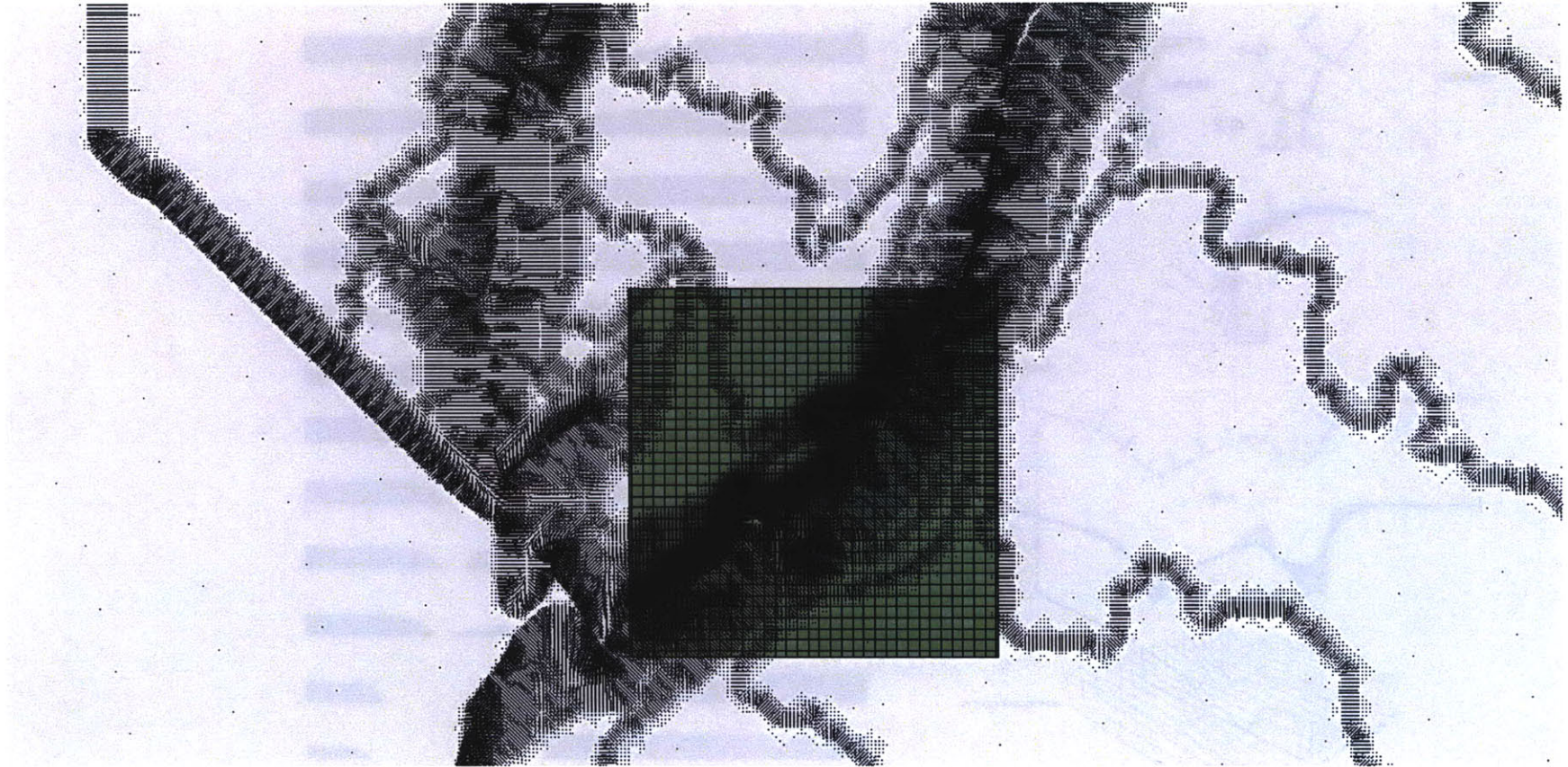

at the same time the topological variation became more evident through the angle and slope of the normals. These geometric parameters were then used as a loom system or scaffold, which emerged as an abstract vegetation landscape of lines, forming a nest-like series of corridors along the different ravine bifurcations.



Left and Right: Analysis of topographic normals populated on site indicating the slope of the different ravines

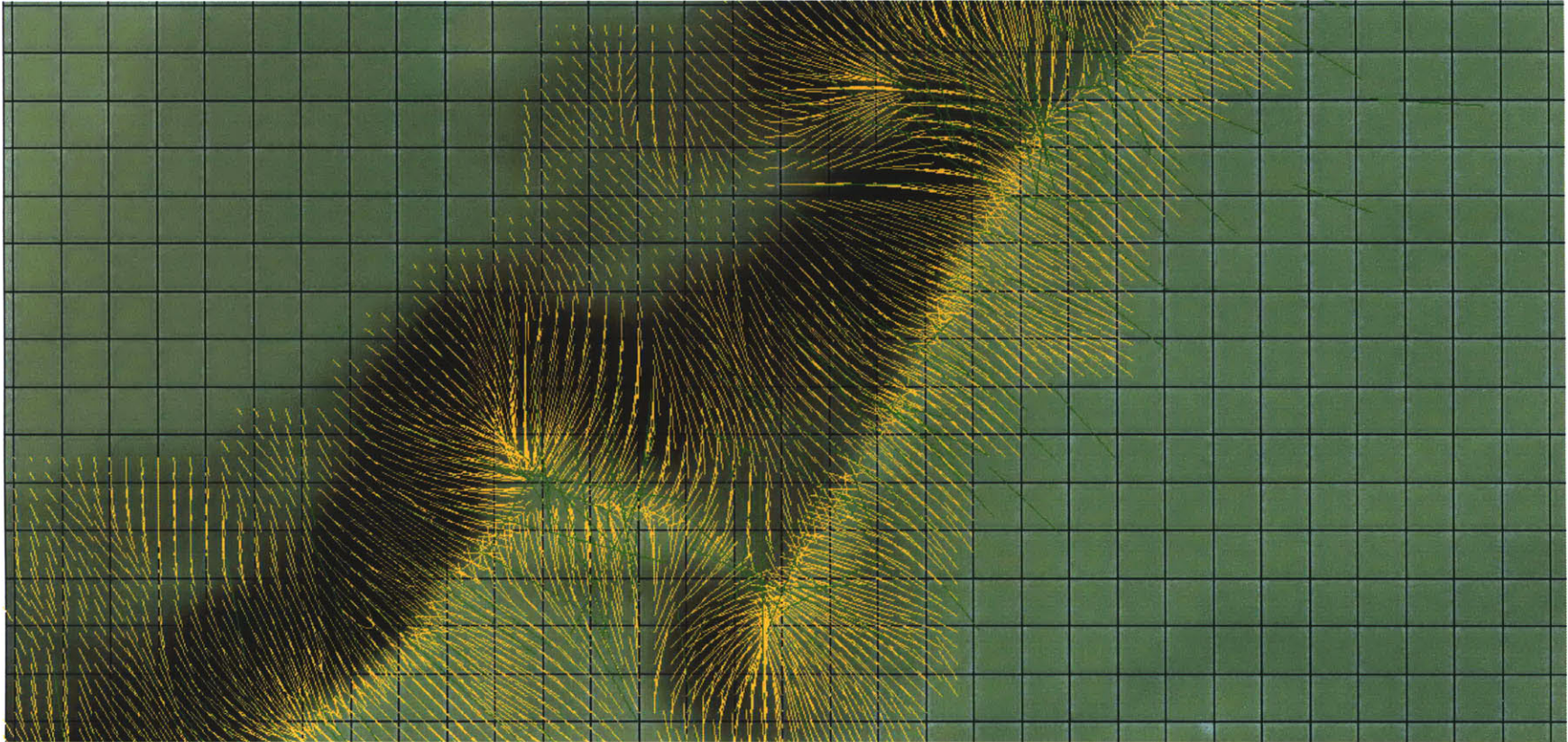

Based on a series of chosen normals at different points throughout the surface of the ravine, a series of ribbons was generated taking these axes as a system of weights that would guide the path of the ribbons and their geometry, while adjusting itself to the topography. These ribbons, in addition to a series of curves weaving together at the base of the normals, were then used as paths for a secondary system of surfaces that began to wrap around the programmatic requirements

Clockwise: Axes of normals; program on ravine; loom system.

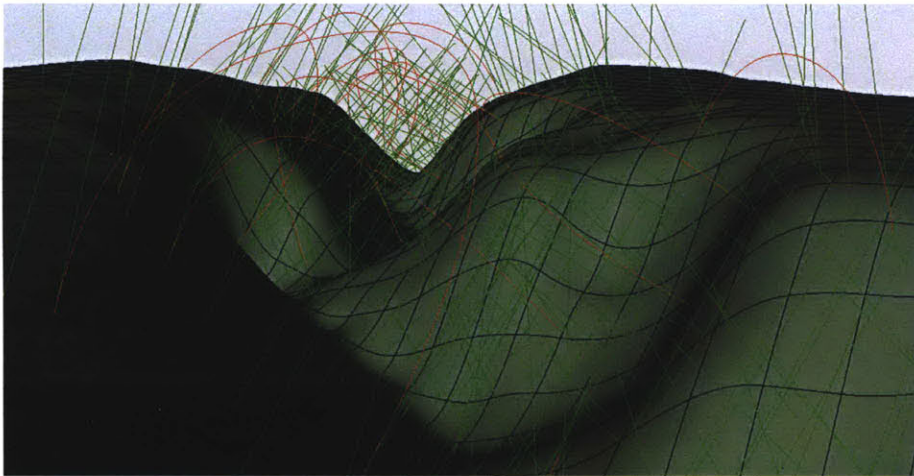
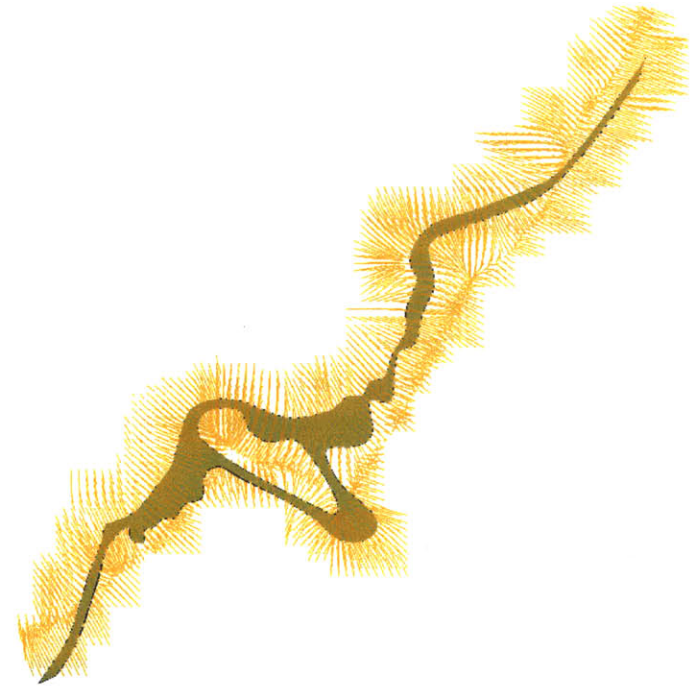
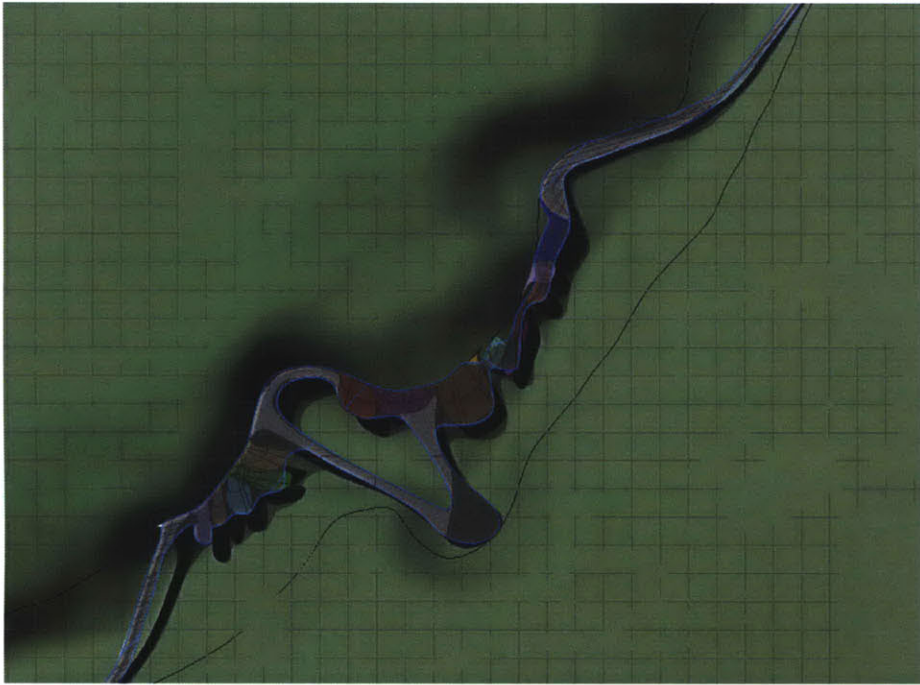

already distributed along the site. This wrapping surface was adjusted according to both volumetric and spatial requirements, connections throughout the program, and required open and closed spaces that would allow different views to the opposite side of the ravine and at different intensities, providing the project with a continuous variation of spatial and visual experience throughout the site. The basic geometry of the building derived from the geometry of the site, and sits as an organic silk-like fabric that follows the variation of the topography. Sometimes the fabric bifurcates into bridges that reach the other side of the ravine, connecting to the main greenhouse, and allowing different connection points between the public university and the residential/commercial areas on both sides.

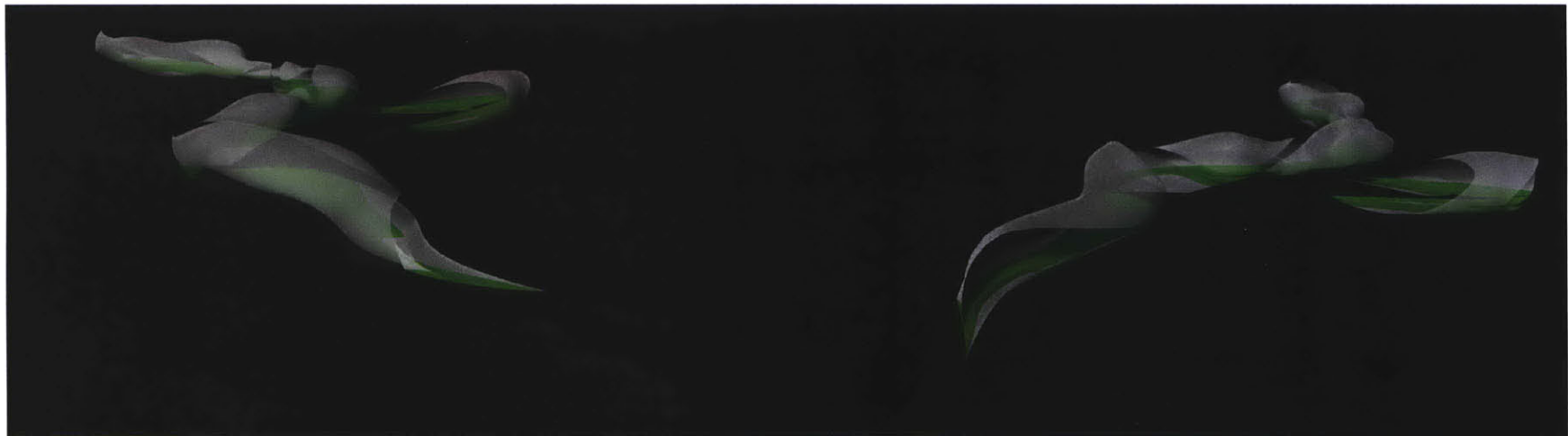
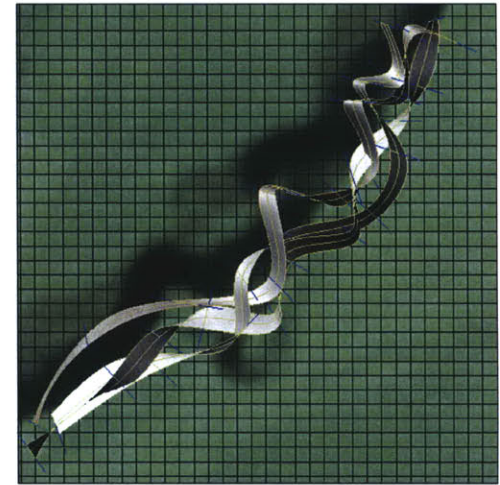

Top: Systems of ribbons derived from the normals on the ravine. Below and right: wrapping surface generated by site and program parameters

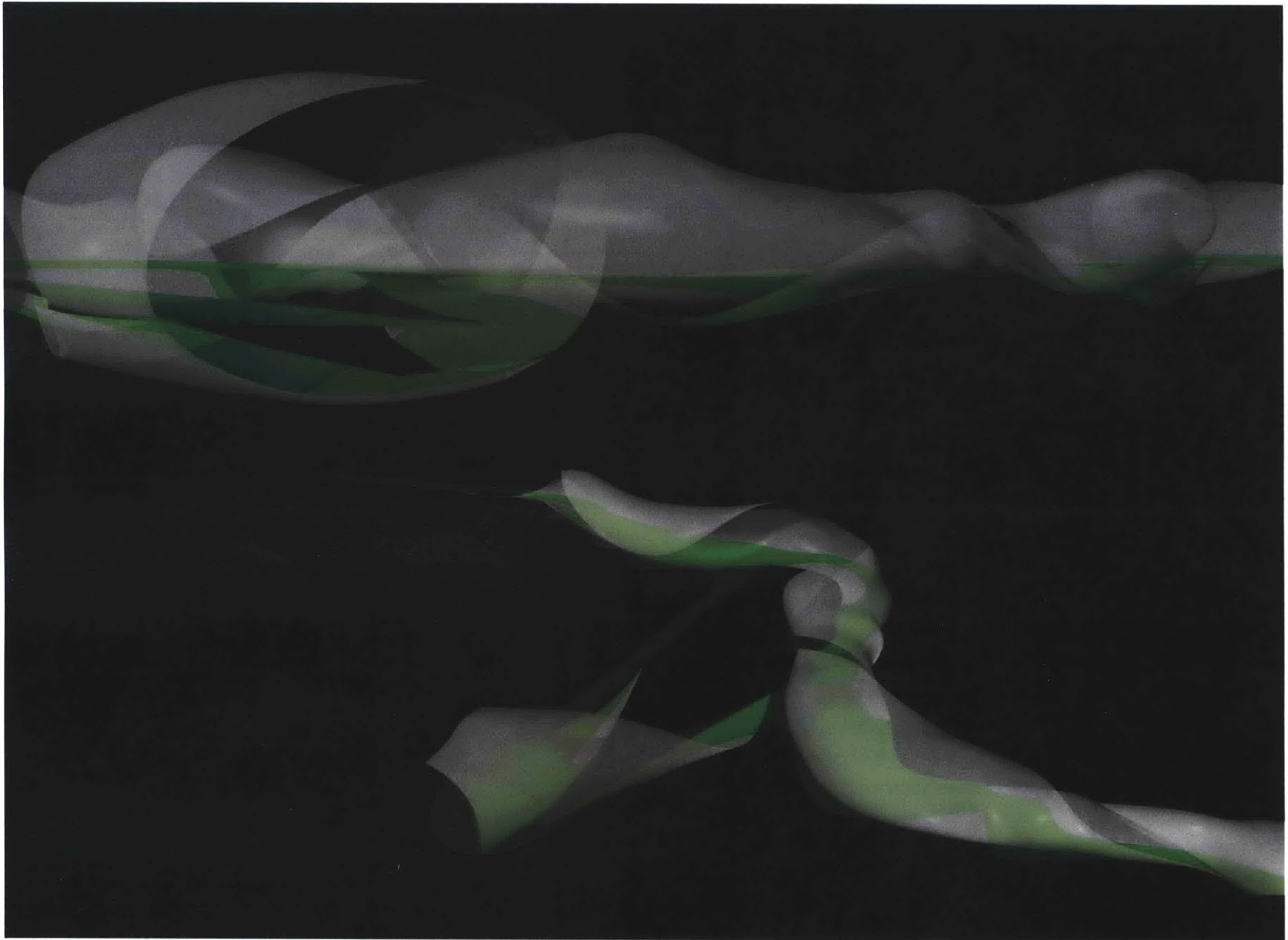

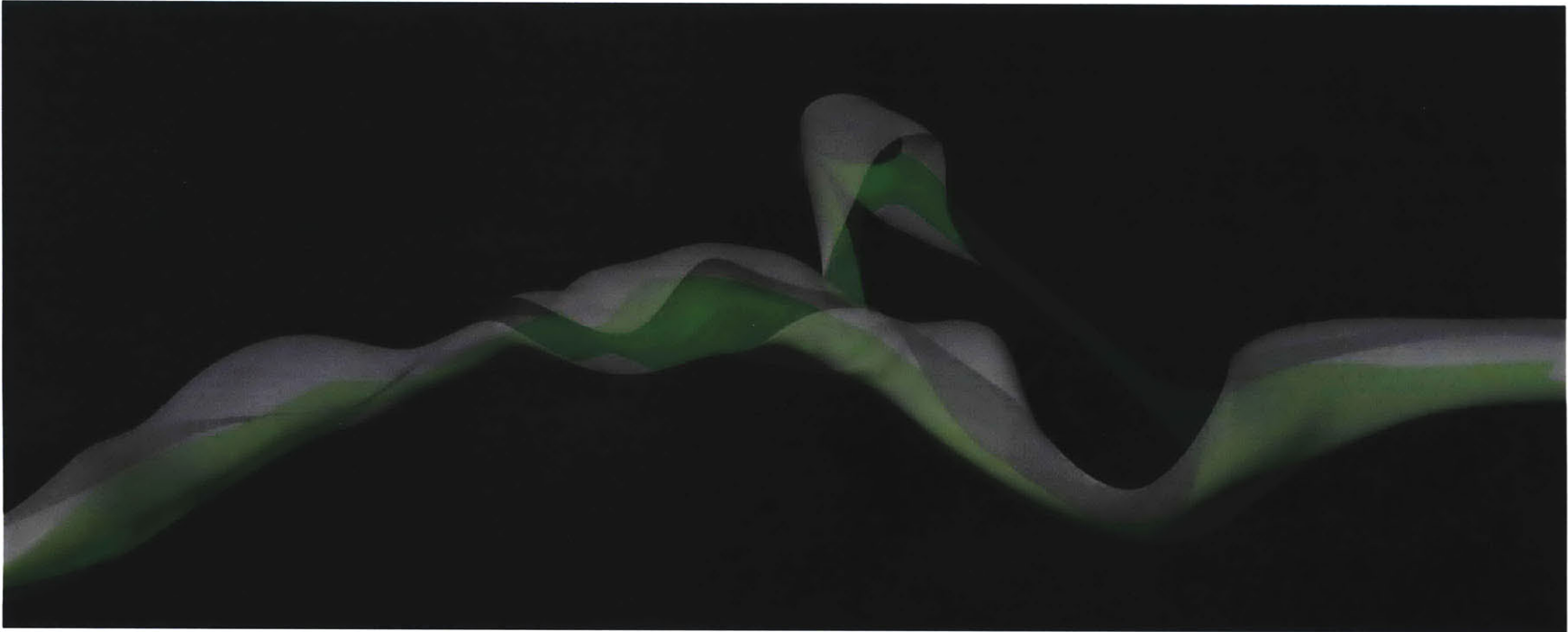

A series of study models were carried out based on the same paper strip models of the site in order to analyze the potential of the system to adapt and generate the curvilinear form of the building across differentiated levels. These new paper models yielded a method of adjusting the surface to different curvatures by tensioning the interior sub-strips and positioning the others on either side of the overall surface. As the side sub-strips reacted to the pulling force in the middle, tensors were placed on one side of the surface allowing it to curve. As more sub-strips are placed on the same side, the curve begins to close in on itself, and a series of radii and slope variation can be combined. This same system caused the initial flat condition of the paper to achieve structural and permeable variation within itself without adding a secondary element, except for the connections between the different strips.

Left: basic geometry of the Ecological Visitor Center running parallel to the ravine. Right: Strips of paper model of bow-system

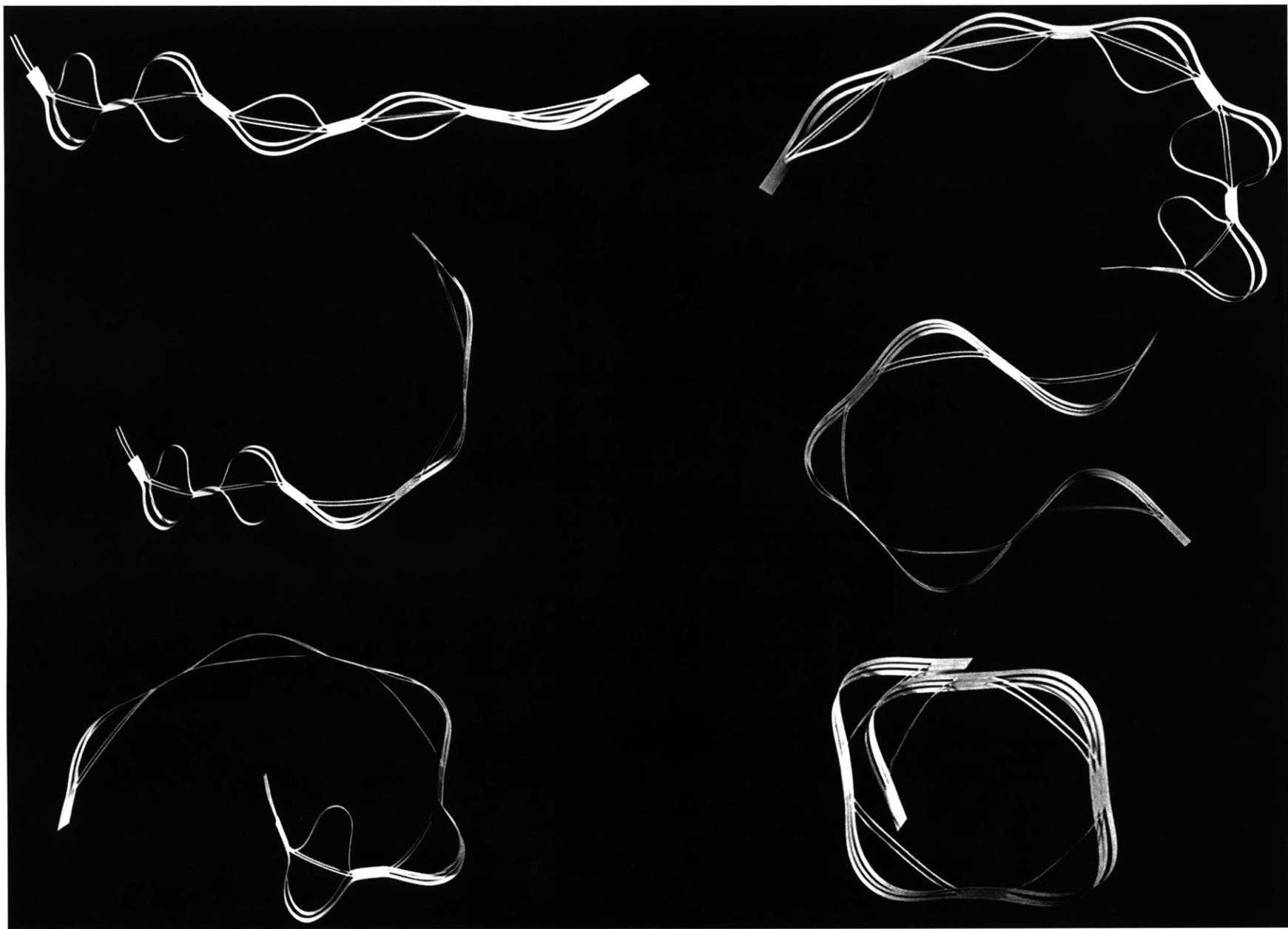

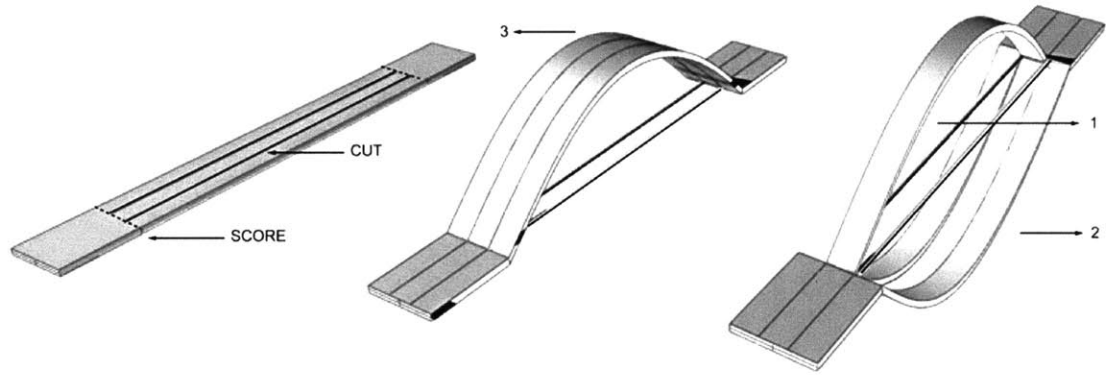
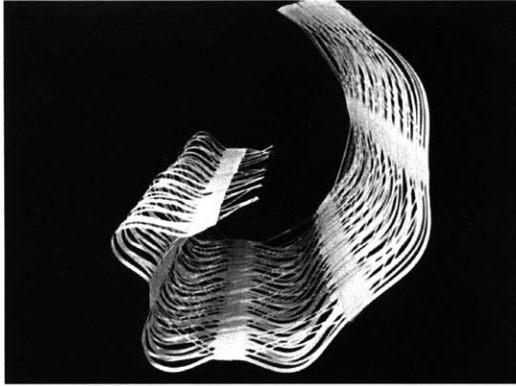

SIMPLE SIDED VARIATION

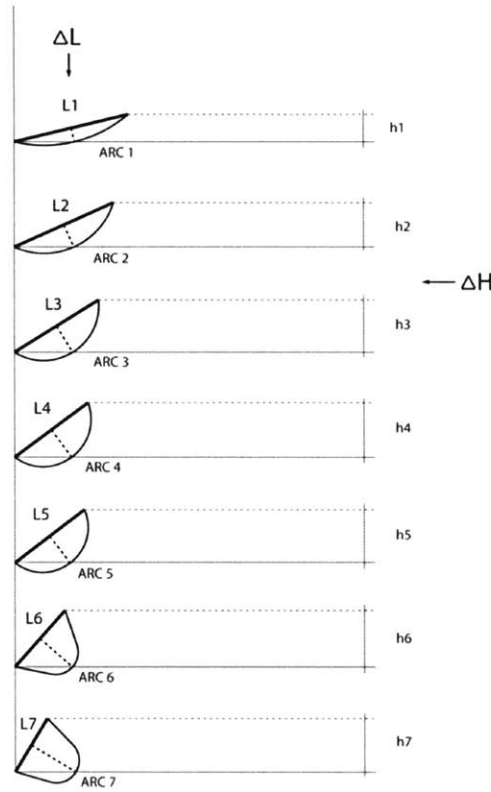

TWO - SIDED VARIATION
DOUBLE SIDE DOWN

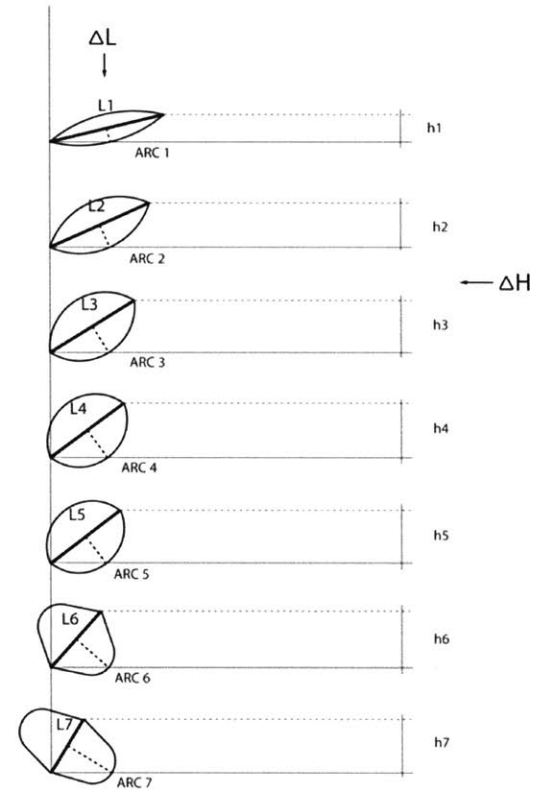

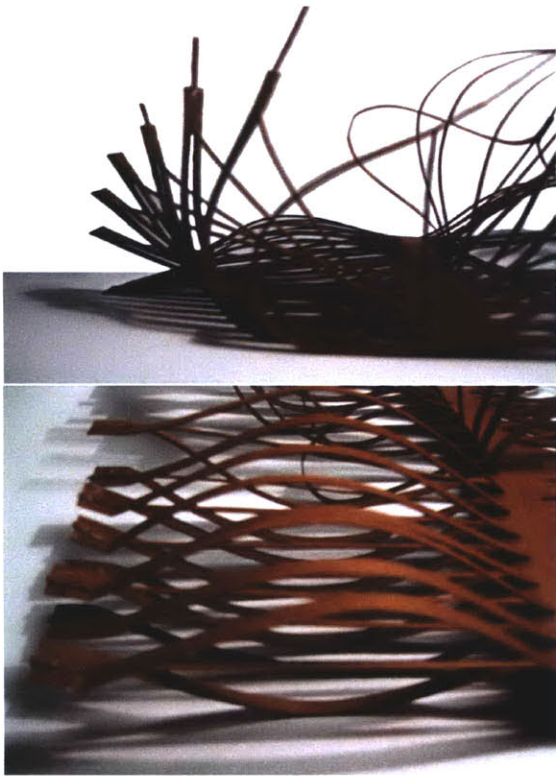

Images: Paper models of bow system

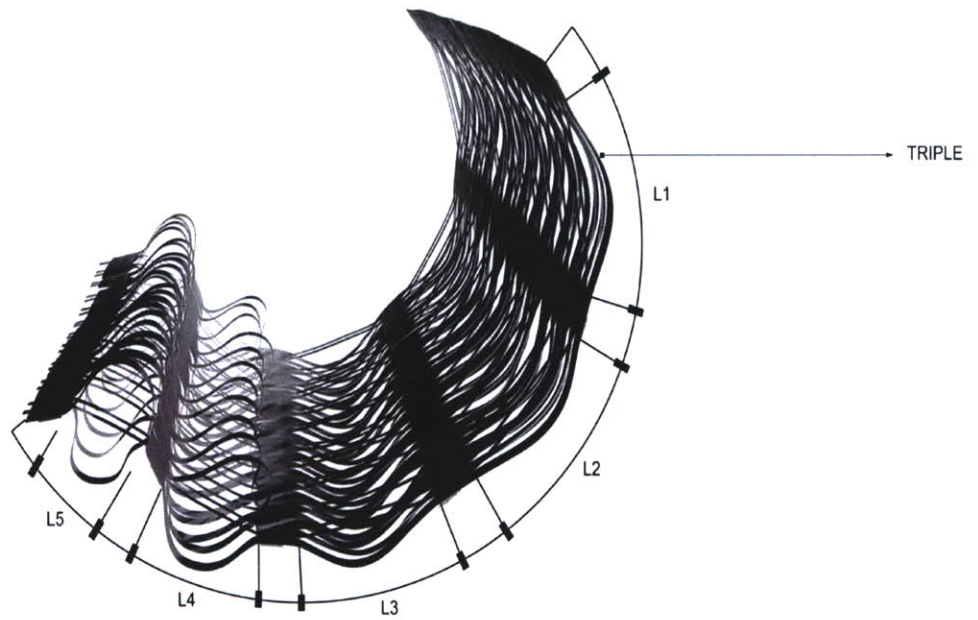
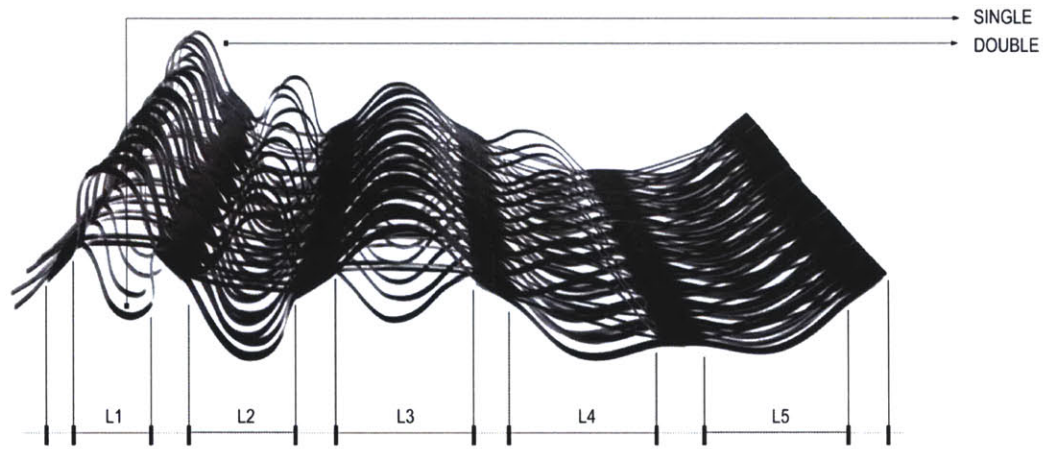

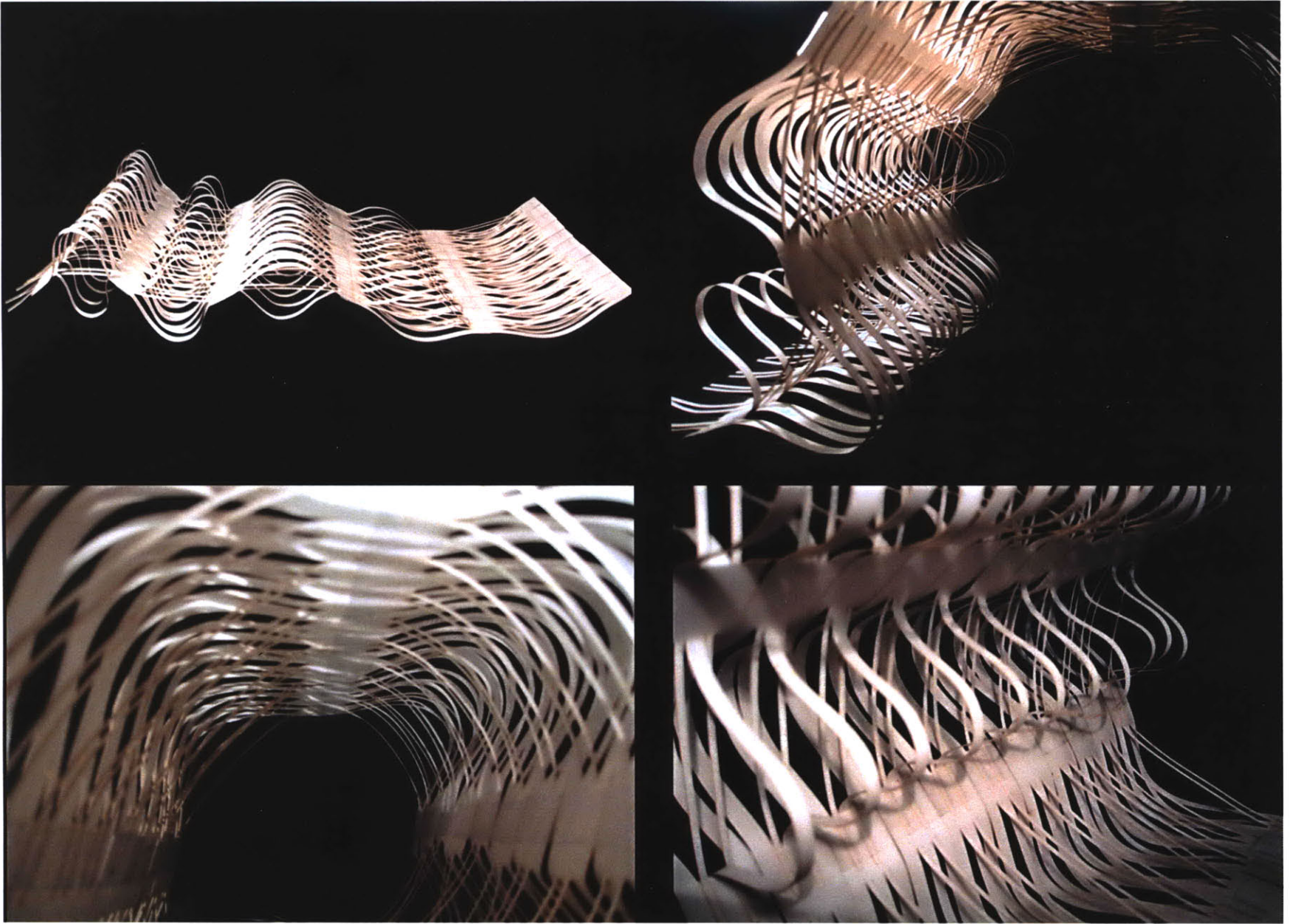

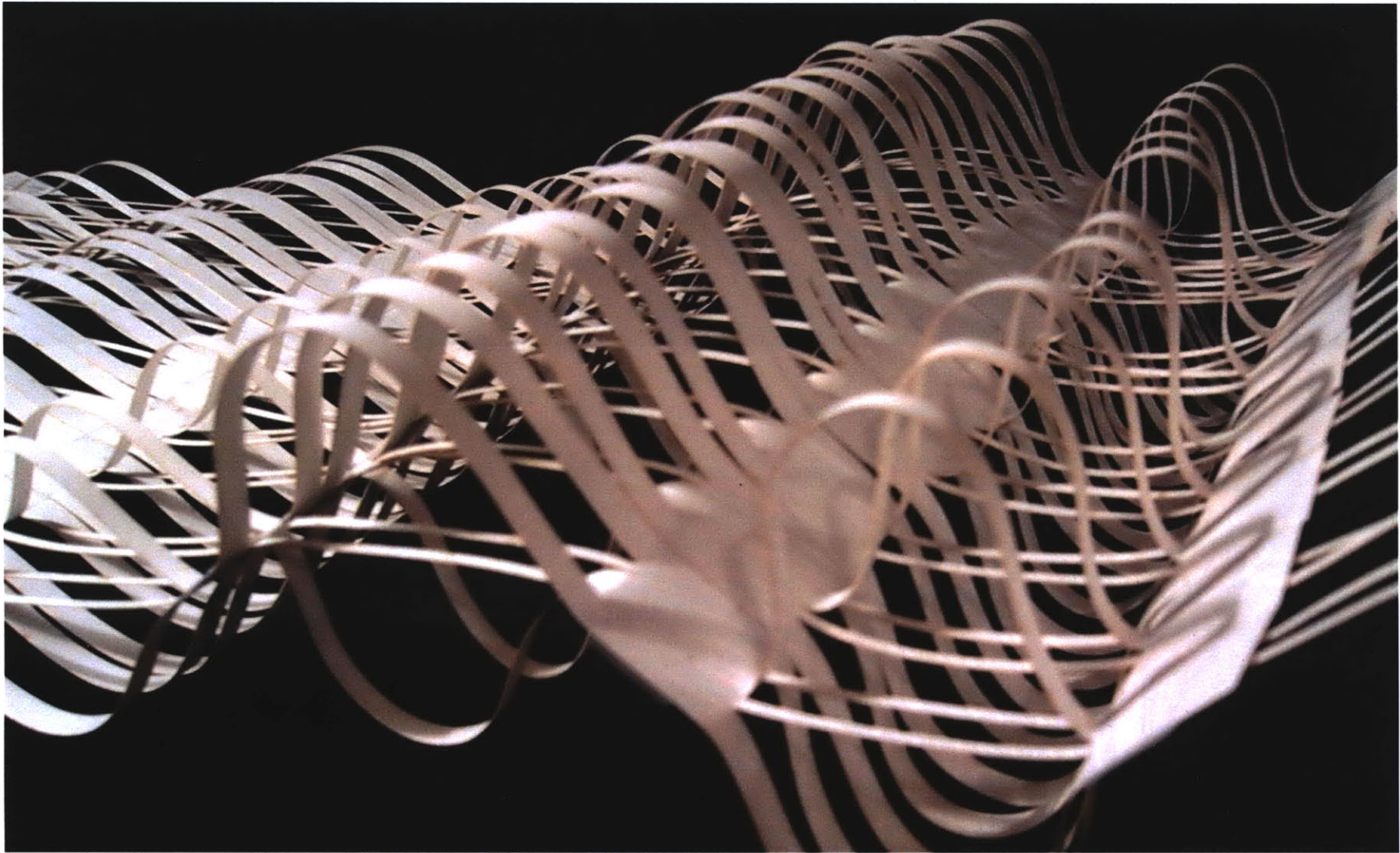

Images: Paper models of bow system

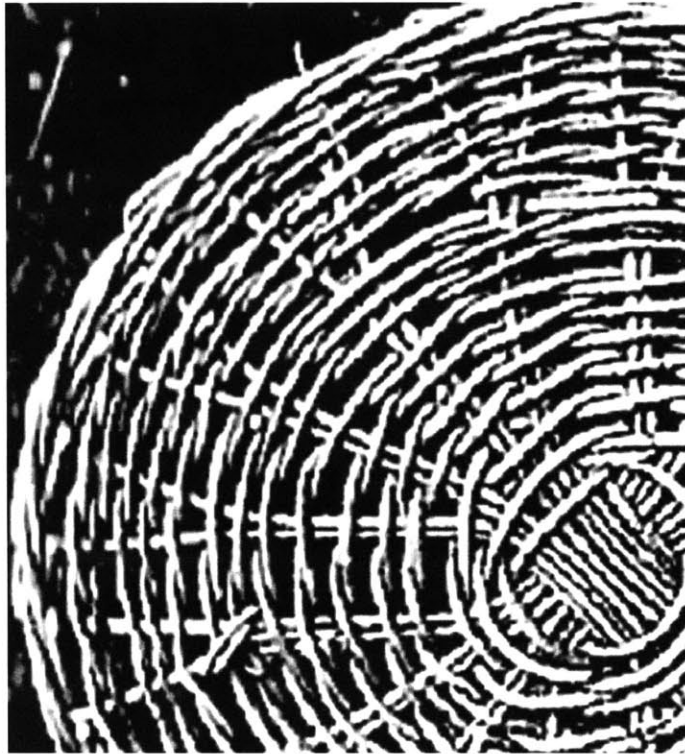
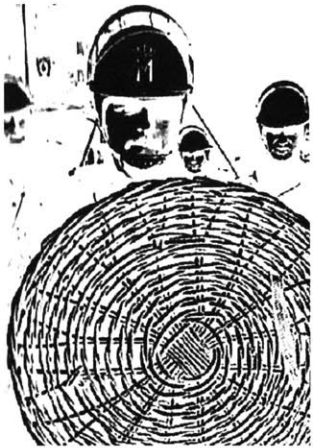
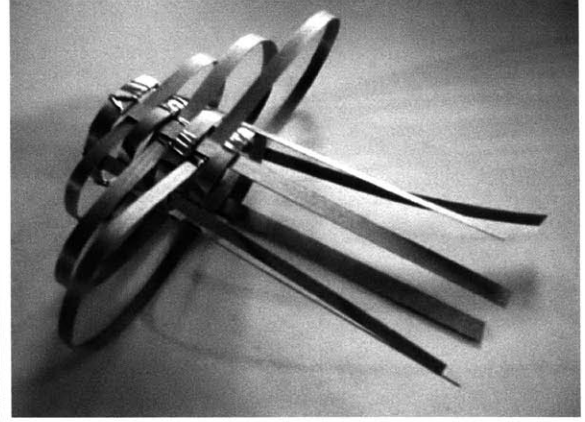
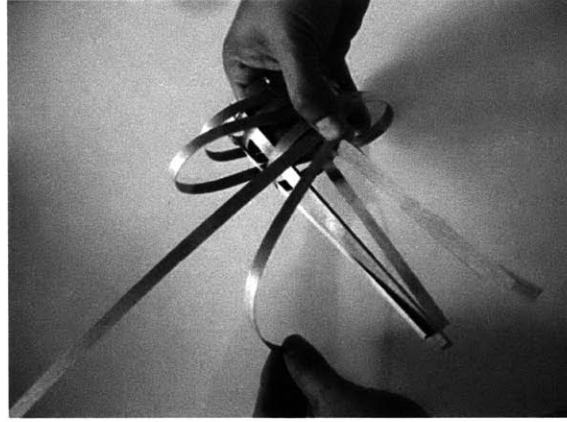
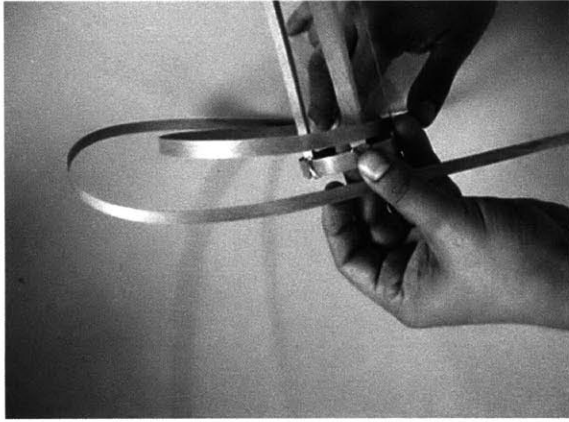
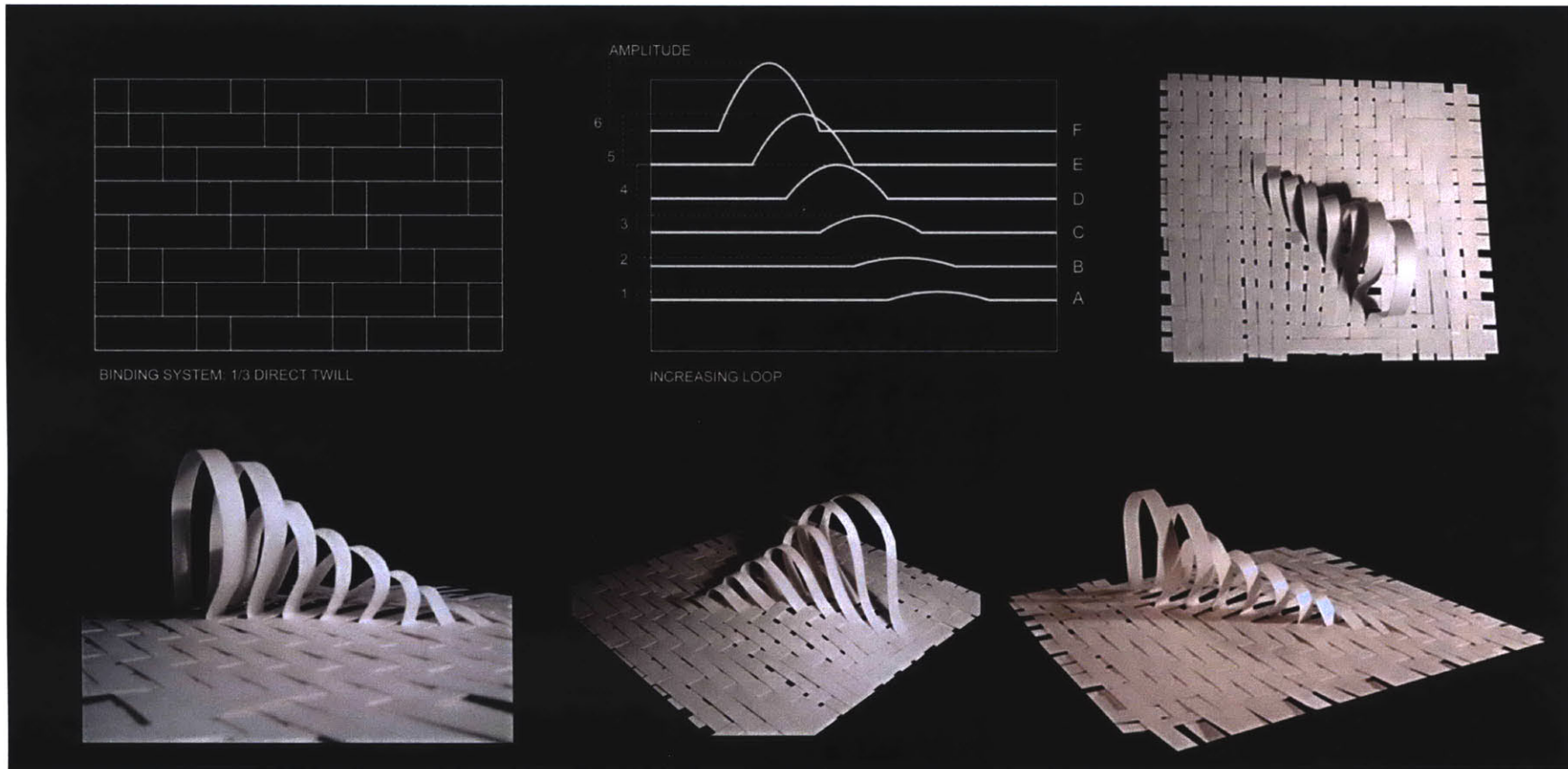
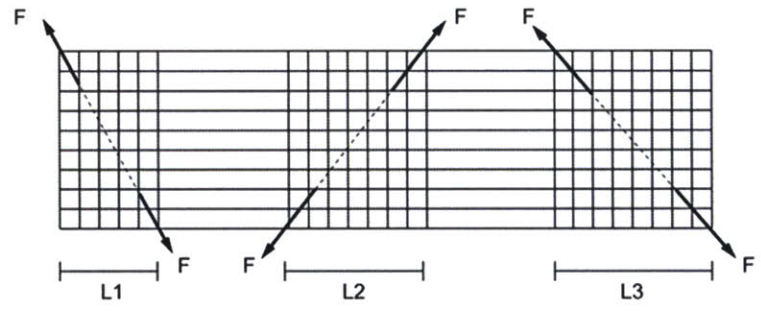
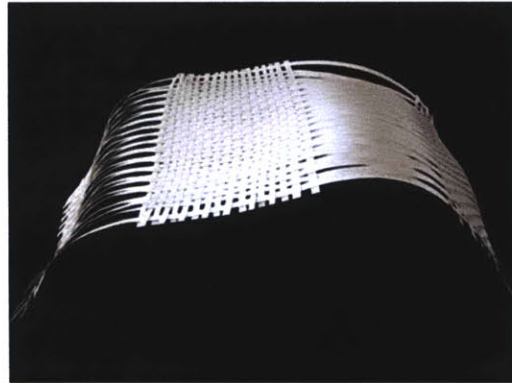
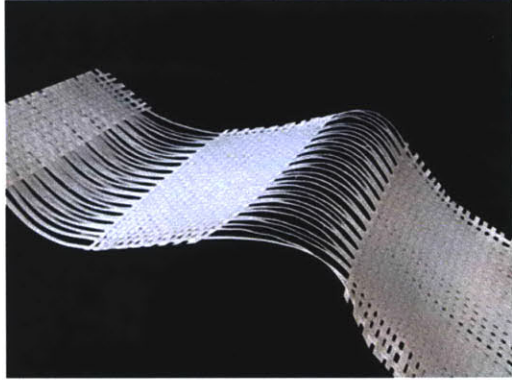

Image 7. Below: Woven police shield. Top: physical models using strips of wood. Right: Woven models and notational system



4. WOVEN FABRICS

To strengthen the models across the perpendicular direction of the strips, a new method of working was developed based on traditional weaving techniques. Based on patterns of the simplest weave structure, or *plain weaves*, formed by weft elements passing on top of and underneath warp elements, a variety of paper woven models were developed. These models were then described in a series of notational diagrams indicating the different points of insertion, the direction



SECTION

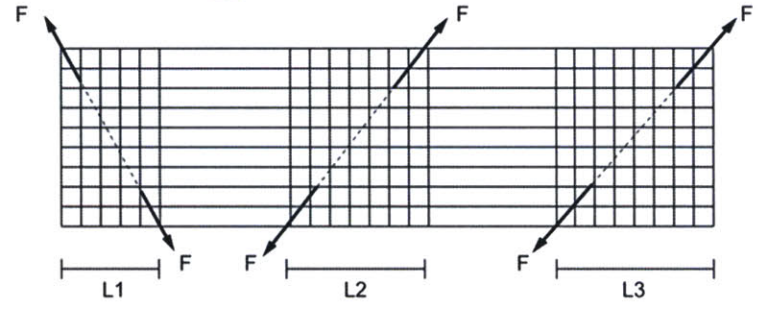

SECTION

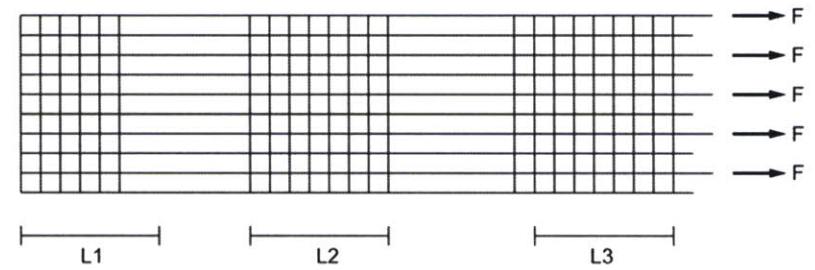

ALTERNATING FORCE

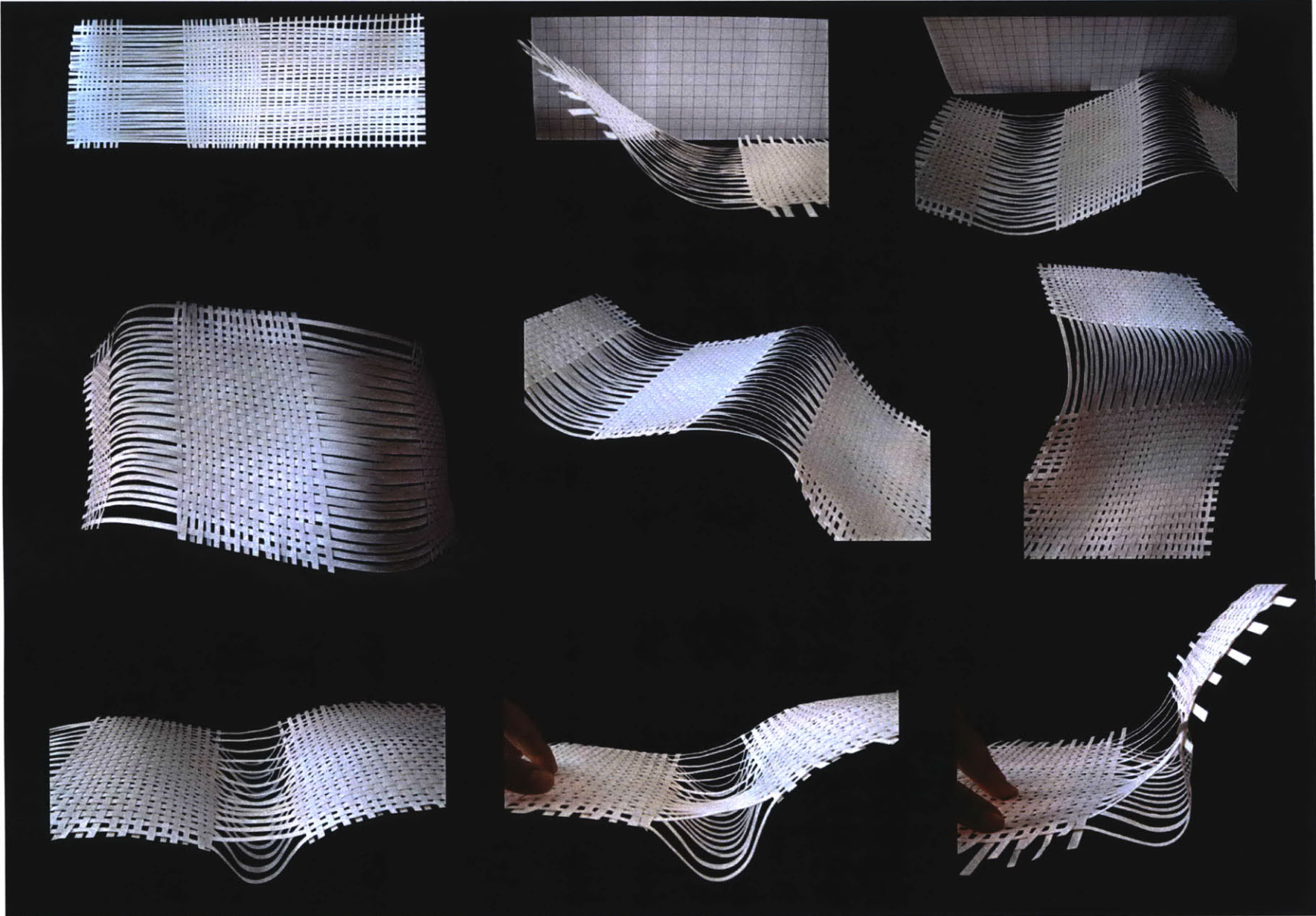

Woven models and their notational diagrams.

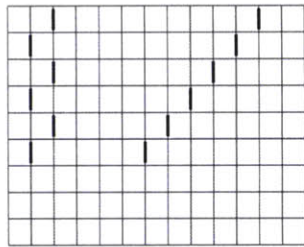

ANCHOR POINTS

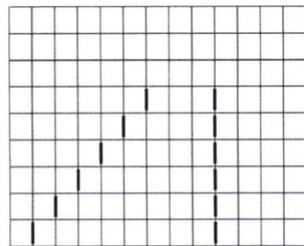
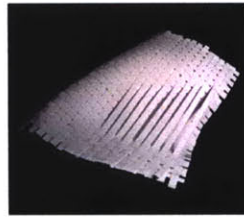
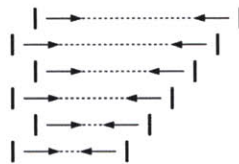

ANCHOR POINTS

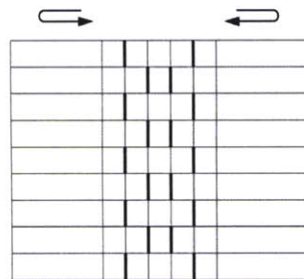
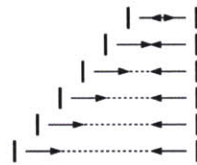

ANCHOR POINTS



of each element in the network, and the applied forces on the woven model once assembled. This allowed for differences in tension and spacing, causing structural strengths and curvature variation in the overall surface. Through the application of forces to specific points on the surface, and the shape retention properties allowed by the friction within the weave, the models adjusted to both single and double curvature depending on the variation of these parameters of the woven system. For example, in areas of condensation of warp and weft elements, the generation

Surface curvature variation. Studies in woven models and their notational diagrams.

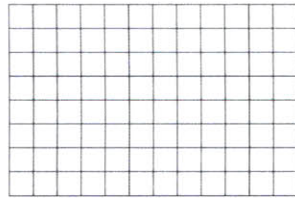
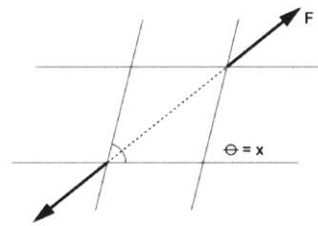
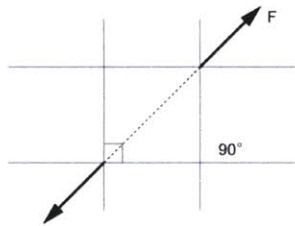

BINDING SYSTEM: PLAIN WEAVE

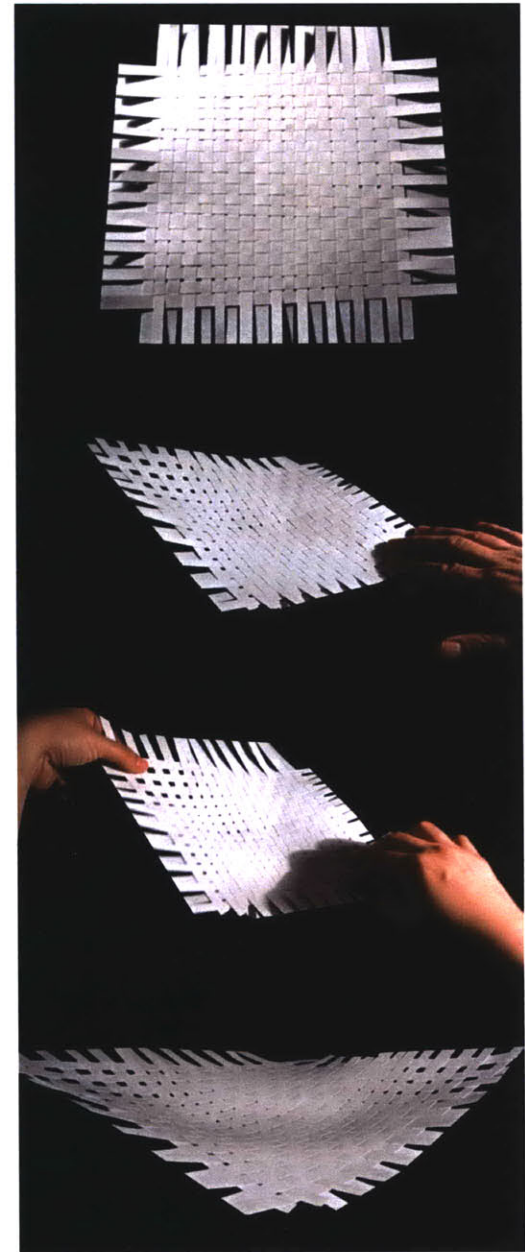
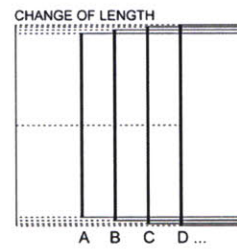
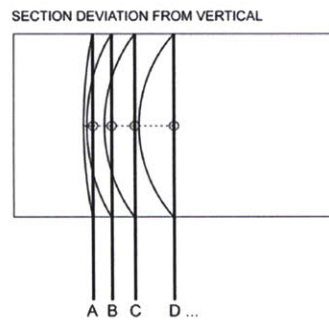
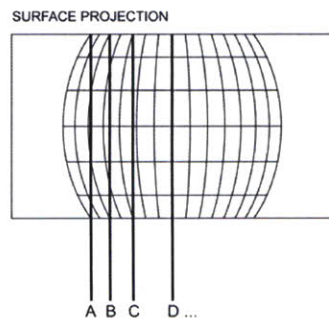
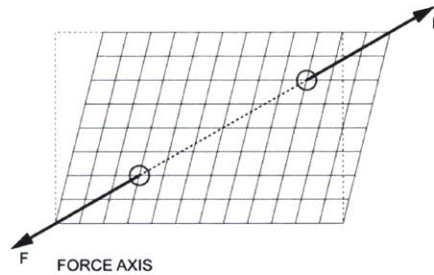

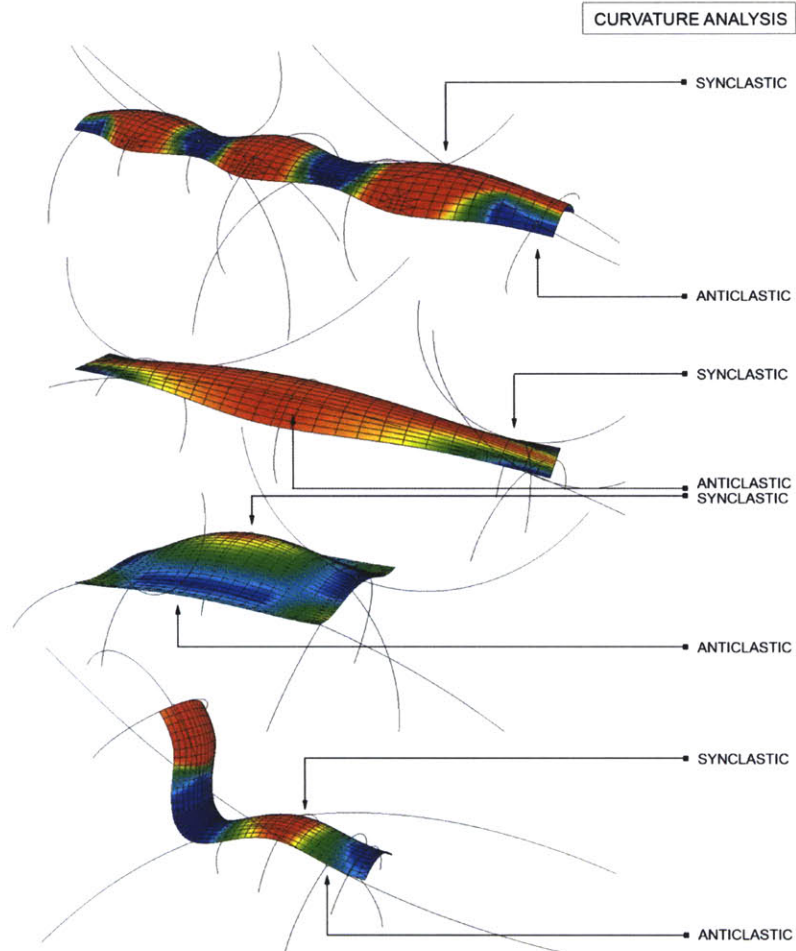

of anticlastic curvature was possible; whereas in less dense patches different synclastic curvatures were generated. The woven system therefore allowed for a wide variety of configurations within one single fabric in order to form the different enclosure requirements, while at the same time providing permeable differentiations that could be used for different light conditions and structural variation. In addition

Left: Curvature analysis of study models. **Right:** curvature and density studies onwoven models, and their notational systems

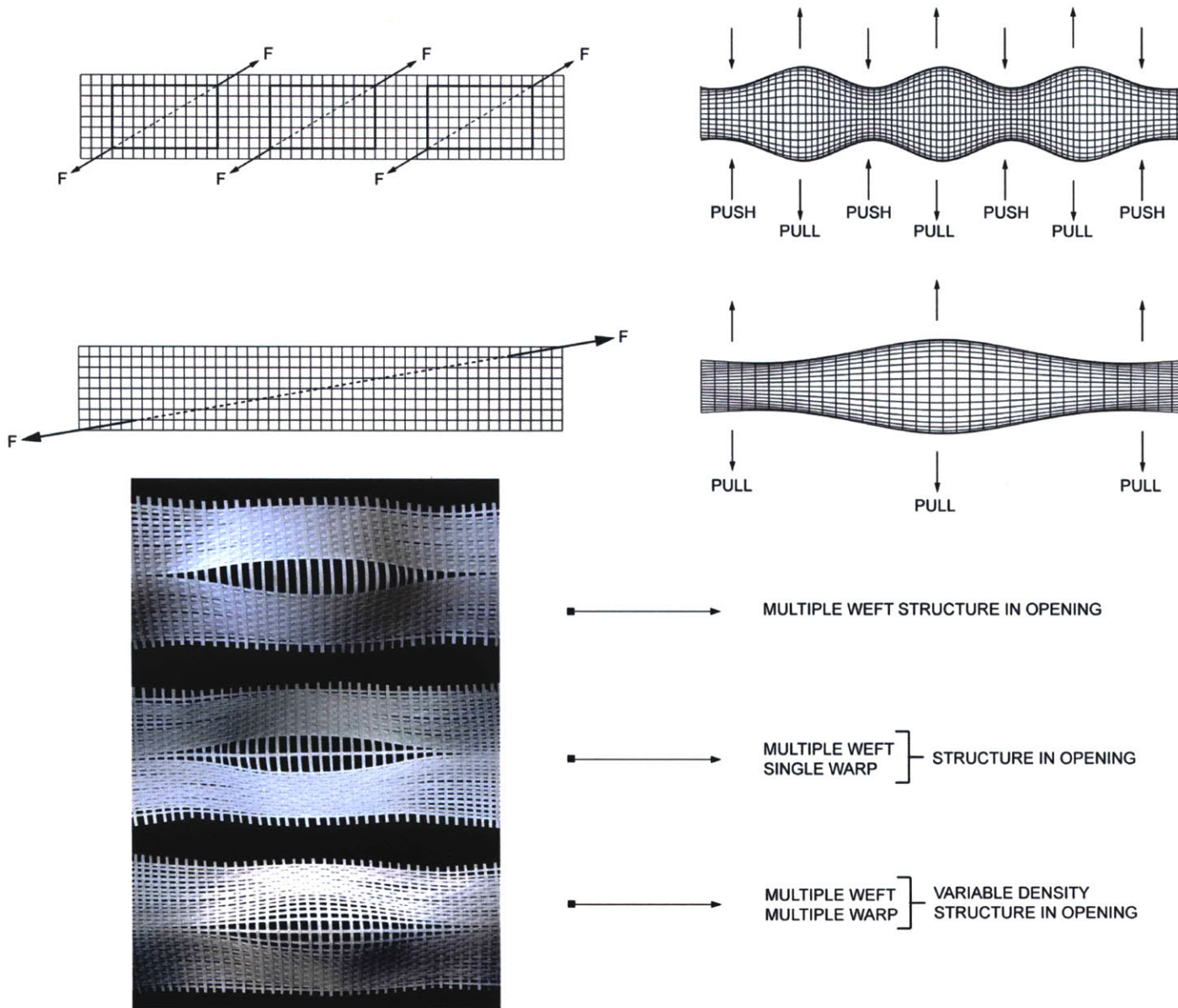

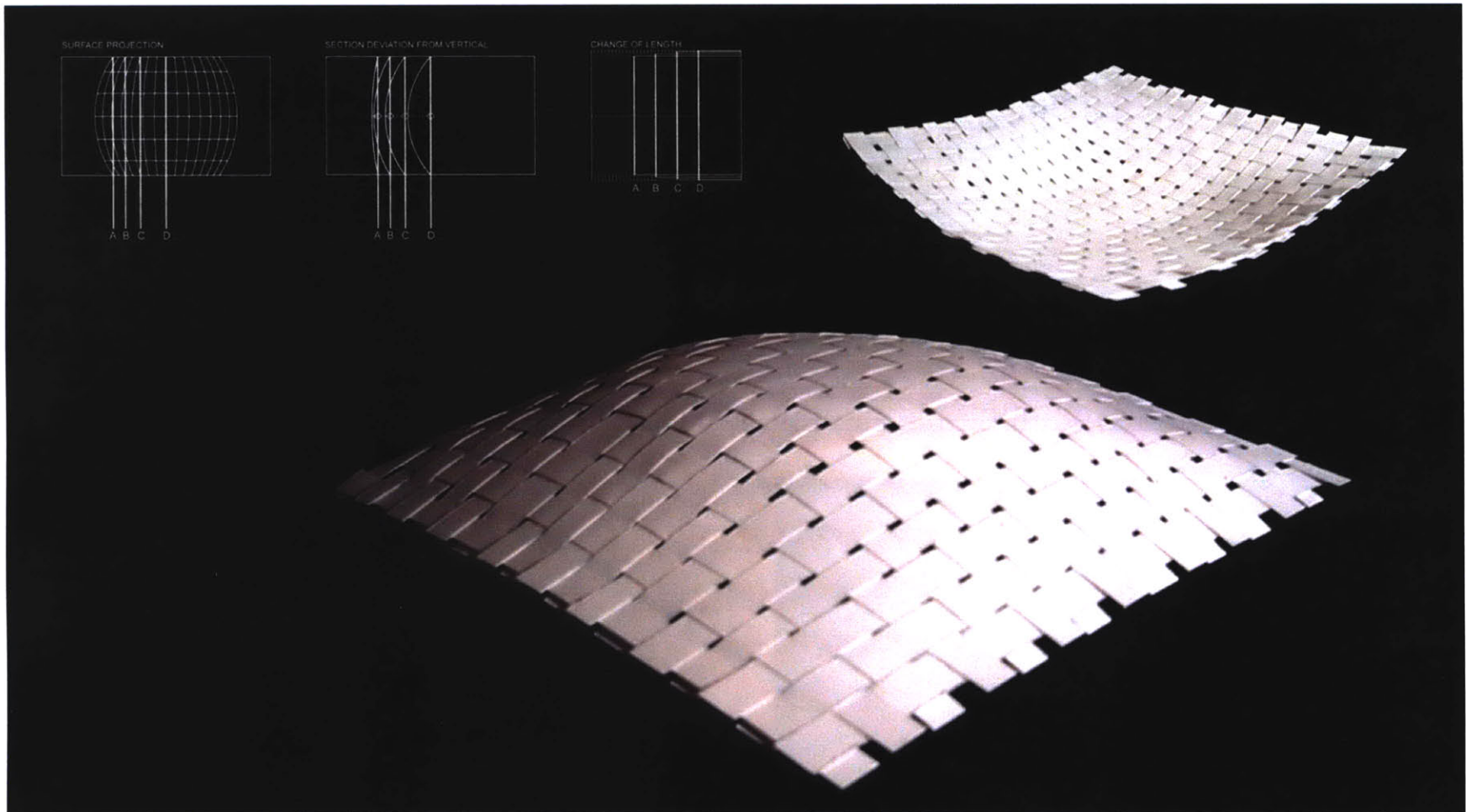

to the physical studies, digital models were carried out in parallel in order to visualize the surface conditions and their application in analogue techniques with the material properties of the paper models. To test the system further, the material was changed from paper to thin strips of plywood, which have less tolerance in bending unless treated with steam. A combination of densities and patterns were employed within one single model to test the variable changes in the surface, while at the same time comprising a continuous transformation.

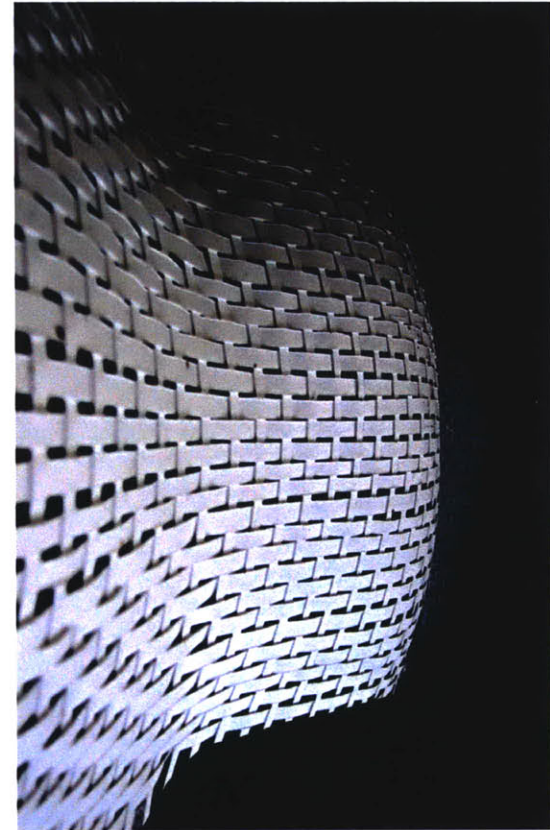
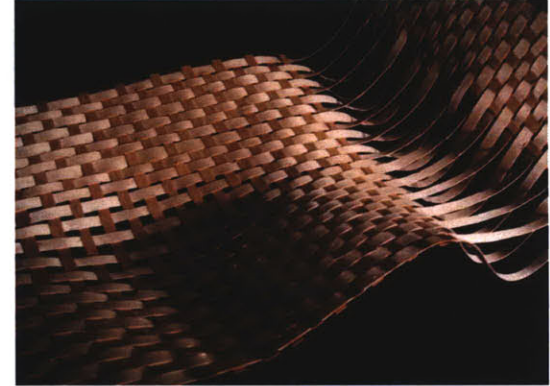
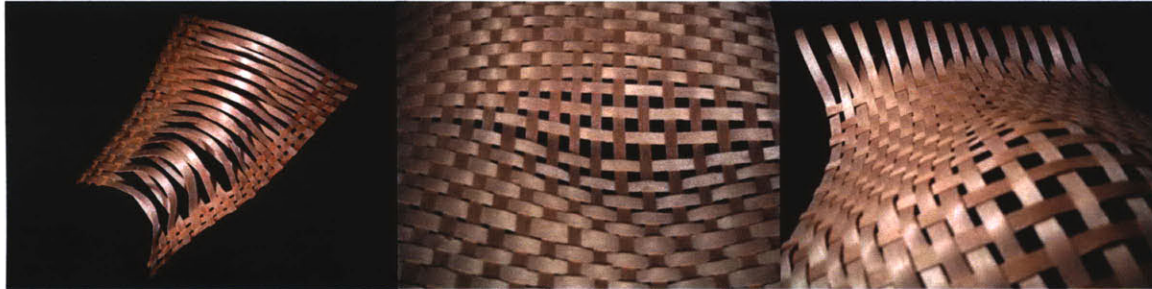
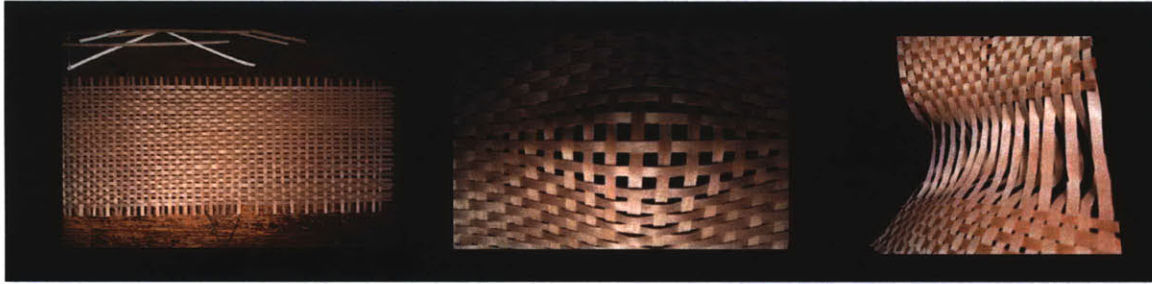

Paper and wood models used to explore different pattern densities, configurations, formal possibilities and surface curvatures.

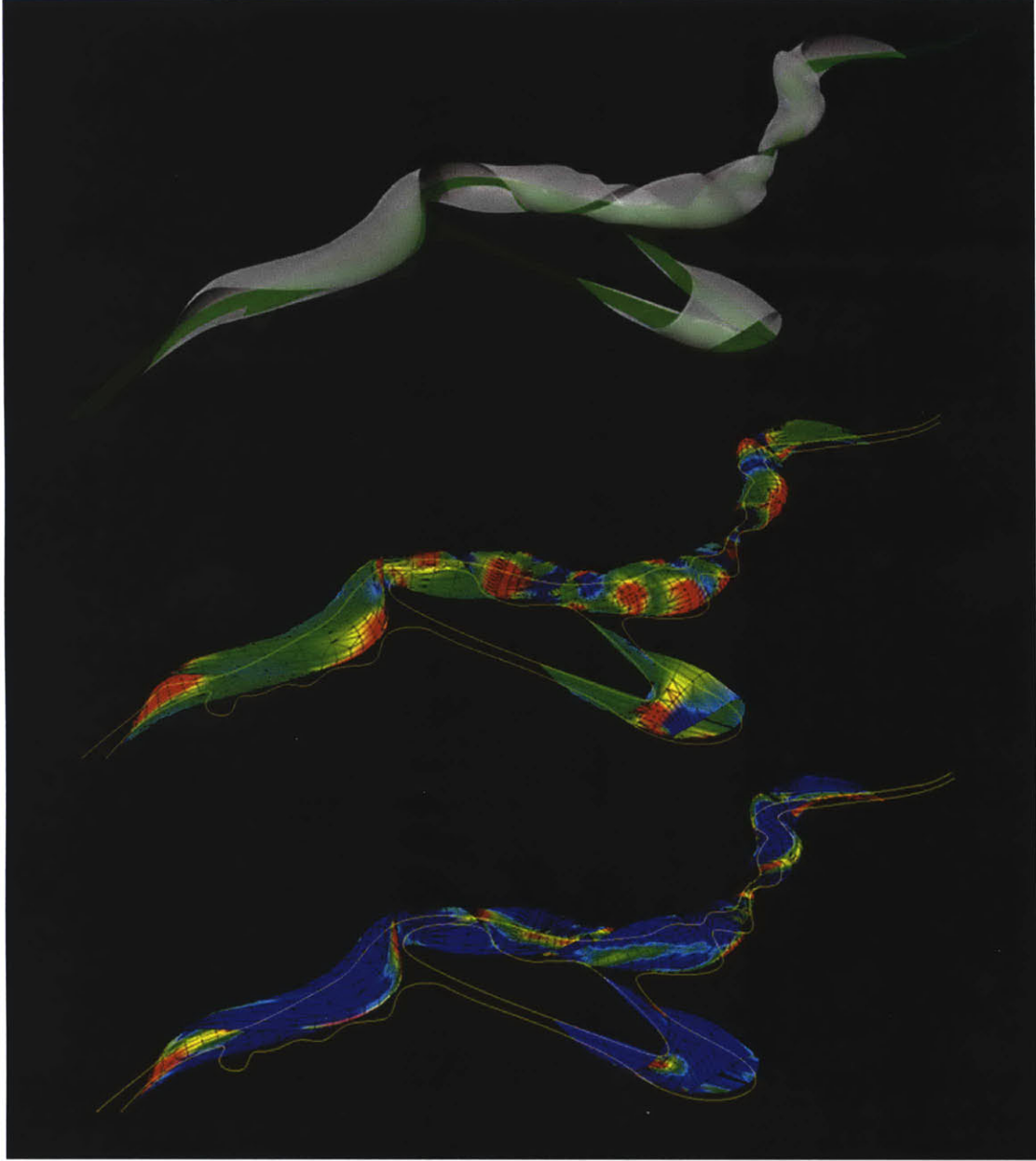

Digital models of surface analysis of the building and woven patterns to be employed in specific locations

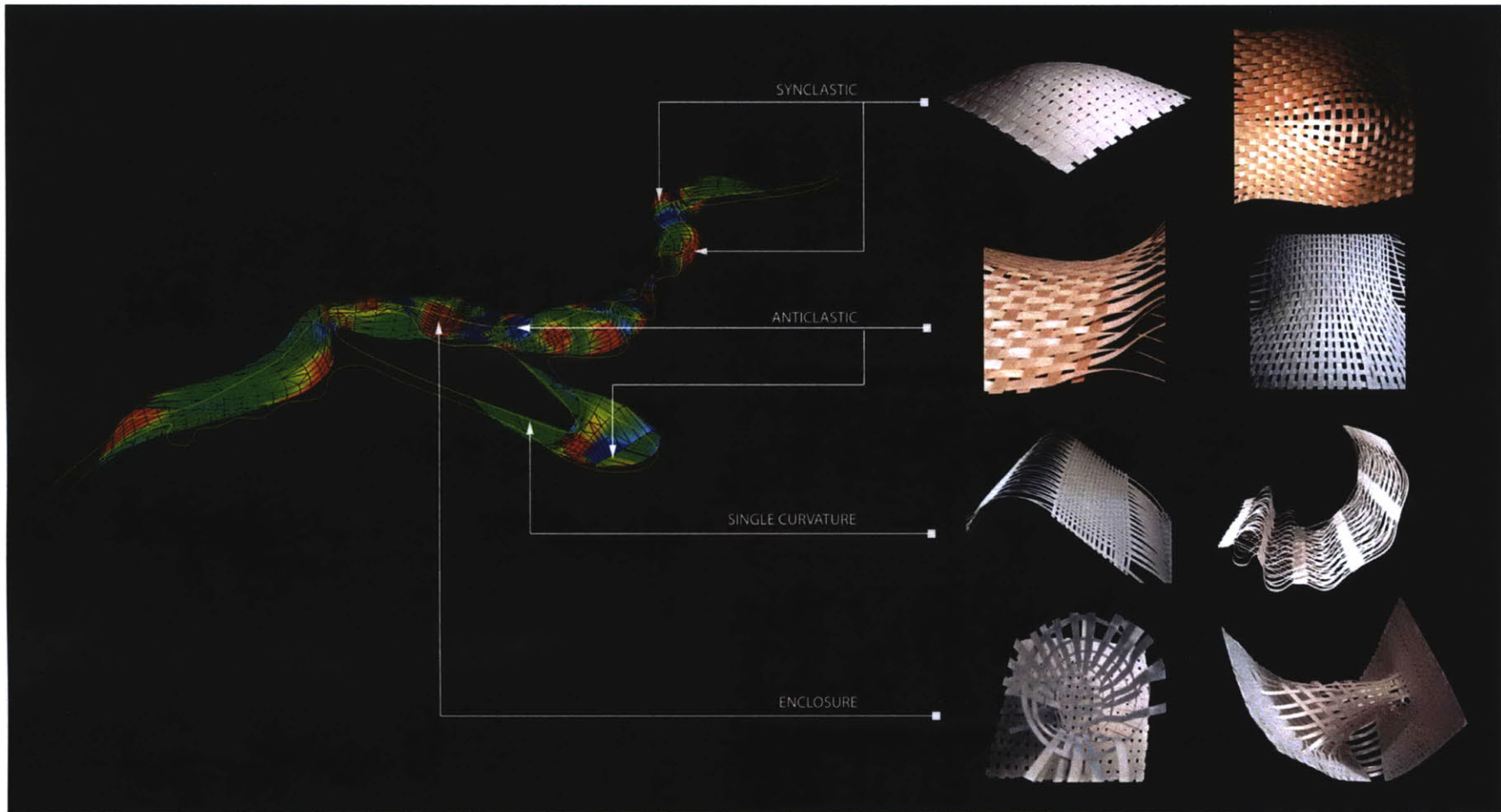

The different surfaces of the digital model were analyzed to locate all the changes: single, synclastic, and anticlastic curvature. Once located and defined, all the possible patterns, systems and assemblies from the physical study models that could adapt to these requirements were assigned and catalogued. This allowed for a variety of choices that could later in the process be narrowed down to a specific system, depending on other parameters to fulfill: from light patterns and formal

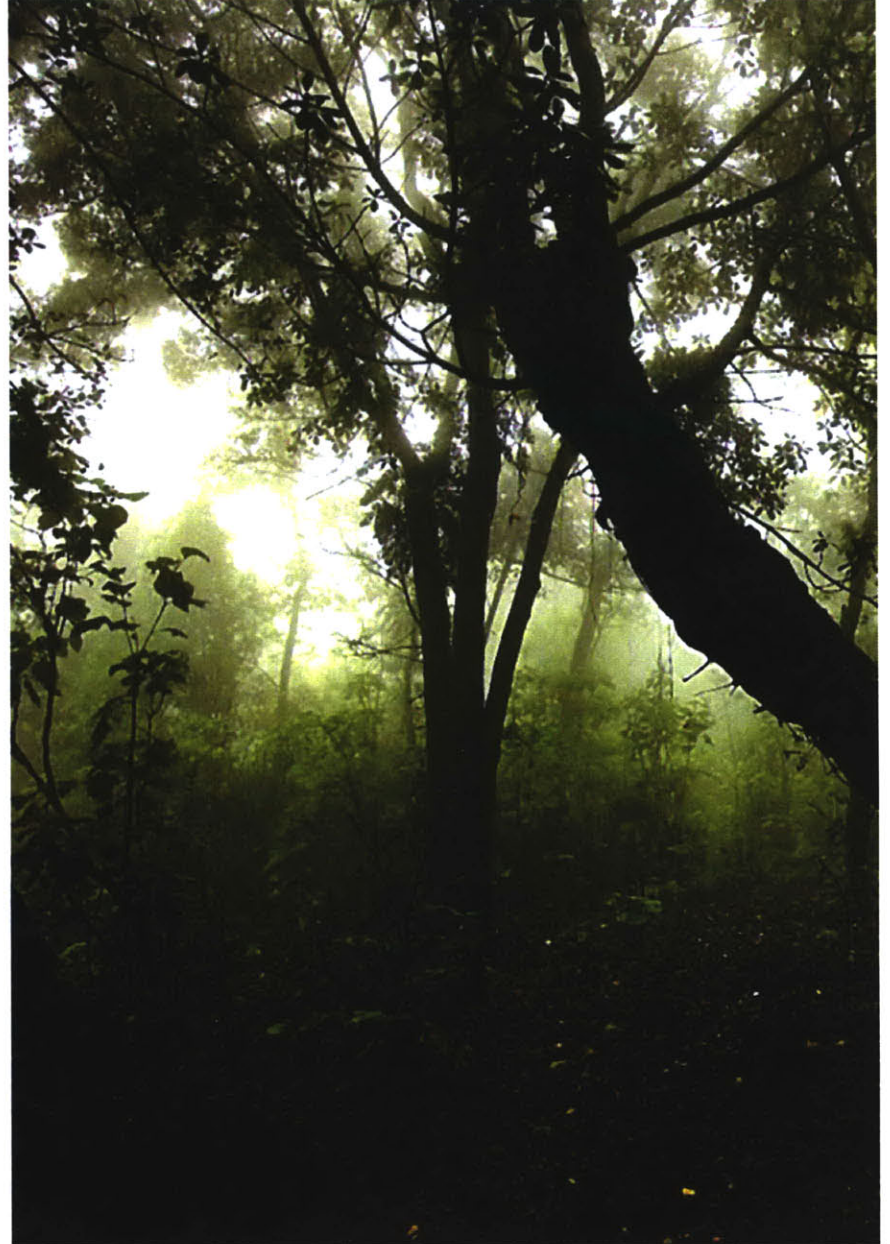
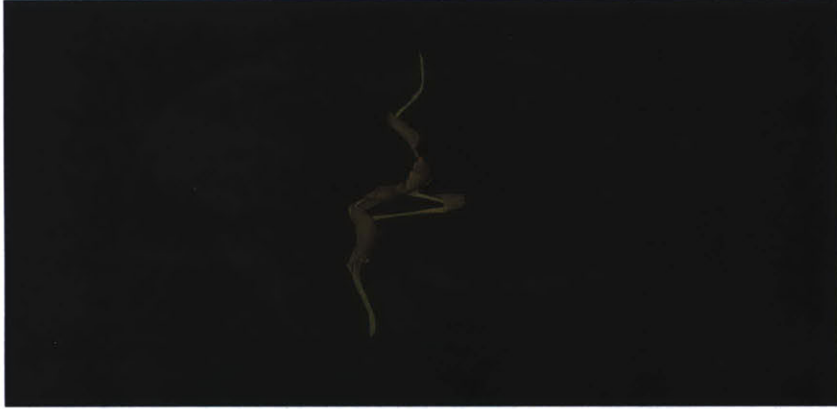

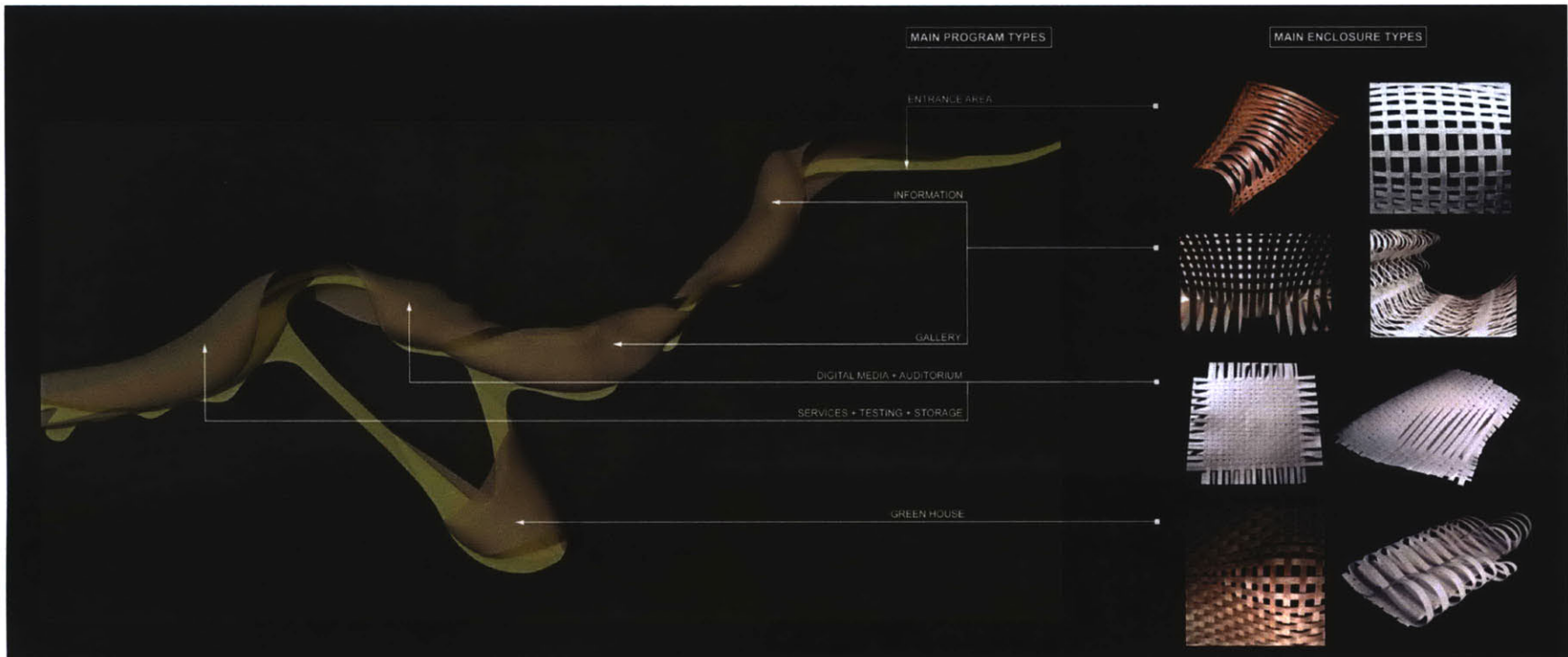
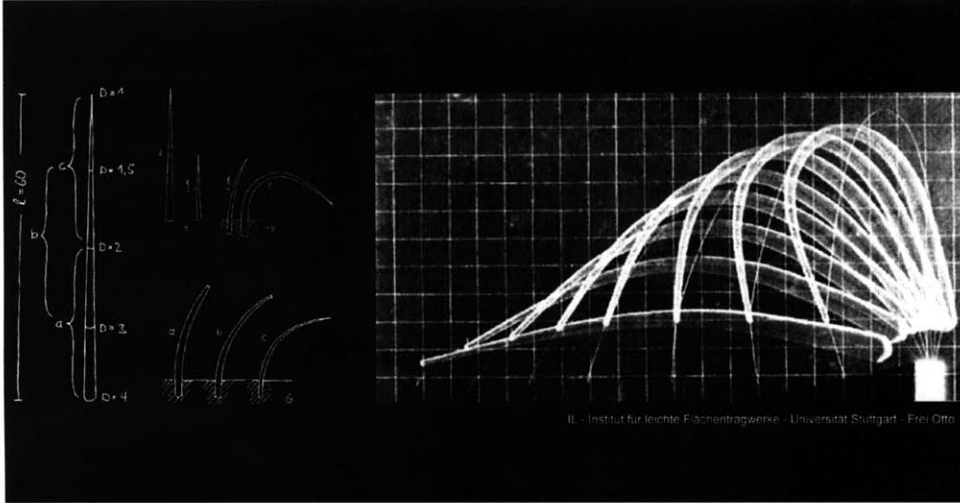

Image 8. left: tropical rain forests in Pacaya Volcano in Guatemala. Right: Digital model of building showing programmatic requirements and different enclosure possibilities.

possibilities, to ease of construction and water tightness. In terms of opacity and transparency, the woven models suggested not only the possibility of a light-weight structure and support for secondary systems of enclosure within the assembly, but the structure itself could provide a variety of densities and patterns in its elements, reflecting the effects found in the natural rain forests of the country. Additionally, the structural system tends to blend with the landscape as an extension of the ravine that branches out in an array of open and closed spaces running continuously and in parallel to the slopes.



5. RAMIFICATIONS

Bamboo was chosen as the main material for the structure. The plant grows in great quantities, varieties, and at very rapid rates in different regions of Central America. Its material properties, such as low weight and high resistance to tension forces, ease of processing (Schaur p. 12), low cost, as well as ease of maintenance and replacement, make it an important material for the project's defined objectives. Guatemala City is also an earthquake zone, and the structural stability of bamboo constructions "erected in regions prone to earthquakes constitutes a major advantage as a result of the relatively low weight and elastic structure of the material" (Schaur p.15). Furthermore, in many traditional constructions, Bamboo has been employed in a variety of ways, from flat panels and conventional structures, to bridges, curved roofs and arched systems. Freshly cut bamboo

Images 9-14: Bamboo and other vegetal rods used for different types of construction.

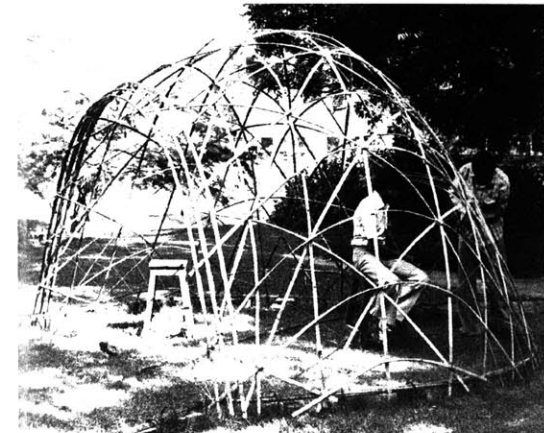
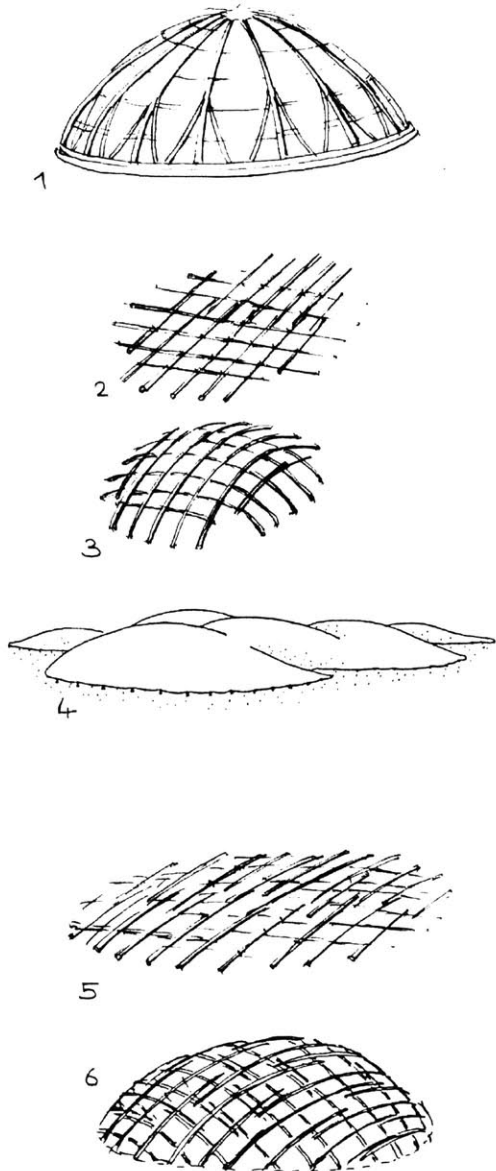

rods are very supple and can be bent between fixed points providing the basic configurations such as vaulted roofs, which could form a span of almost 15 meters. Larger spans for domes and vaulted roofs are possible by connecting two or more rods to one another. In terms of load bearing capacity, structures such as double curve grid shells can be fitted with rods in the form of rings at the base (Otto and Gass p.32). These shell roofs are then covered with a secondary layer for water tightness, such

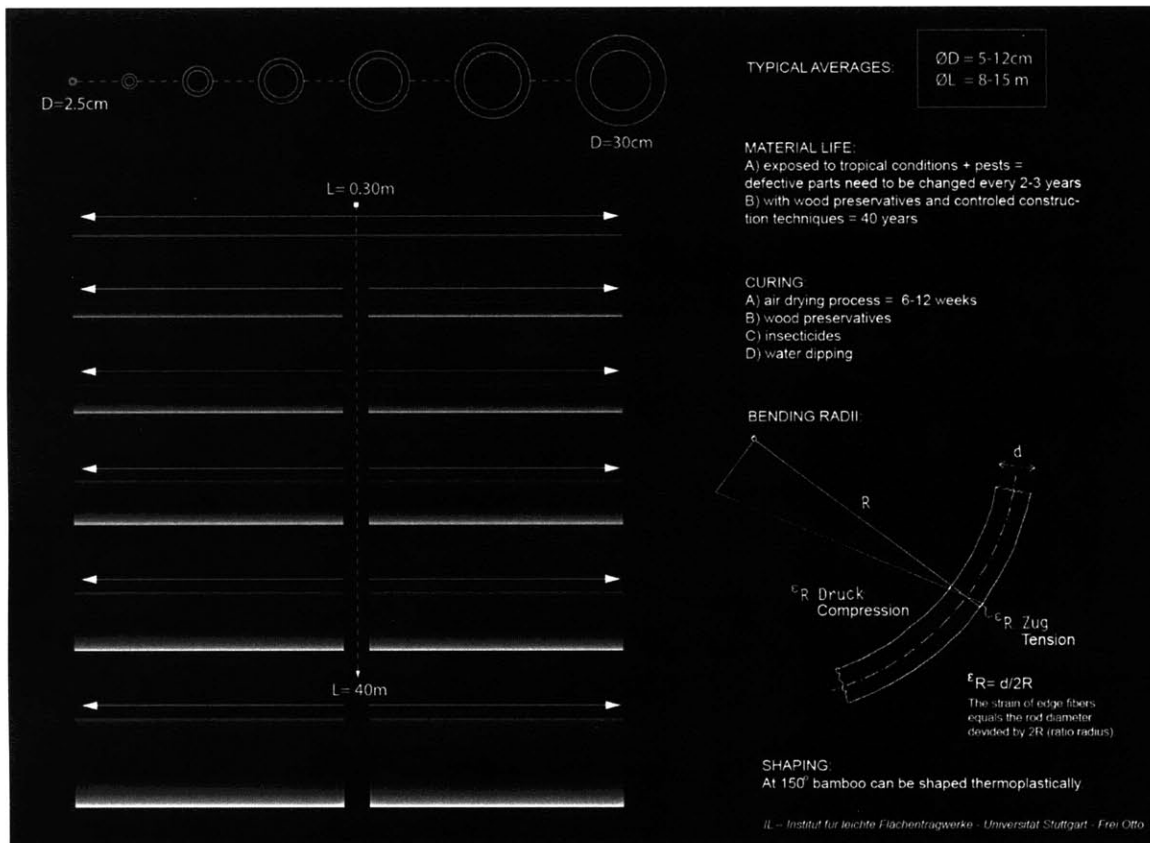

as sugar cane or palm leaves. One example of these structural systems and ease of construction consists of gratings that are constructed on the ground with joints that are bolted loosely to be able to turn freely in the grid plane and then lifted up to form shells. In these structures, "...the rods turn against one another at the joints, and the original rectangular mesh takes on a rhombic shape. If these angles are stabilized by reinforcing the joints or by fitting diagonal members in the mesh sections, structures with good load-bearing characteristics are produced" (Otto and Gass p.34). This strategy was employed for the grid shell above the entrance to the Klostersee Hall in Sindelfingen, where the grid rods were assembled together with the first layer of edge rods, and loosely bolted to one another, the joint plates already having been connected to one rod. The

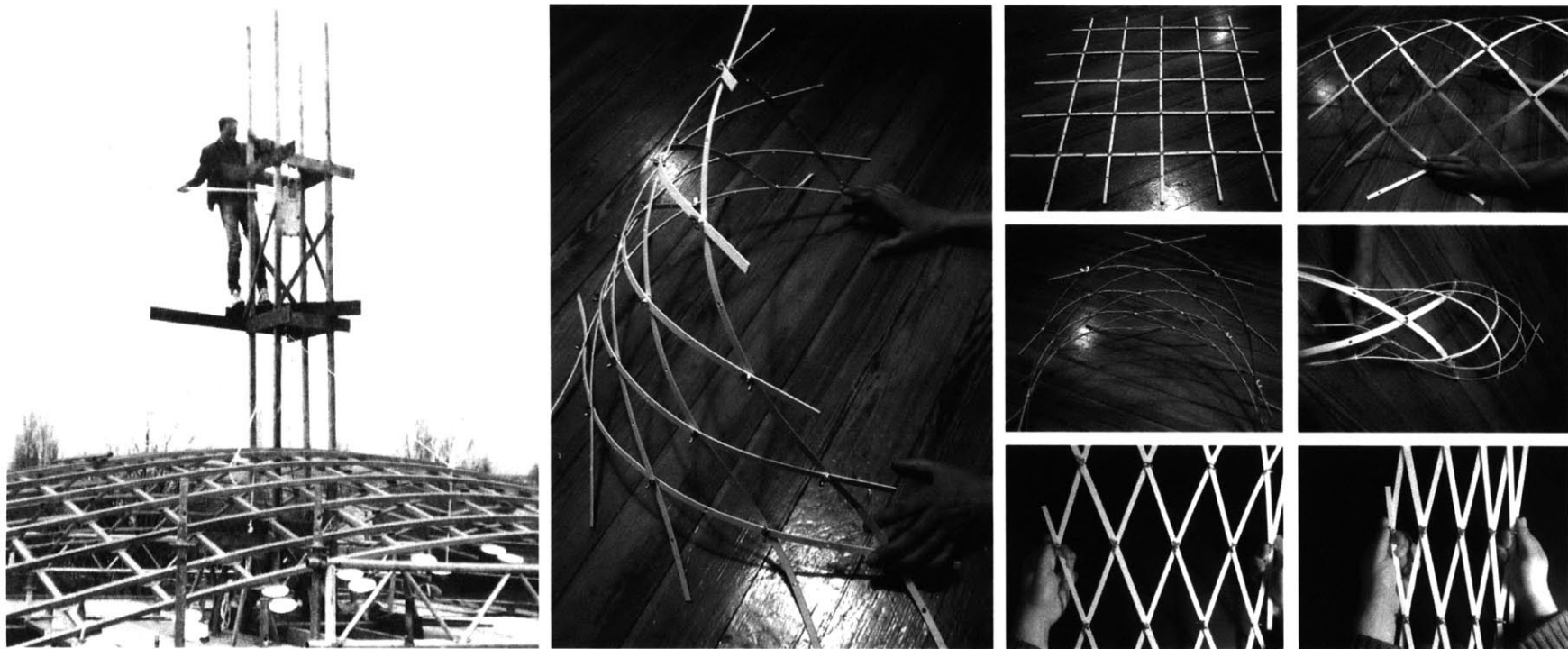
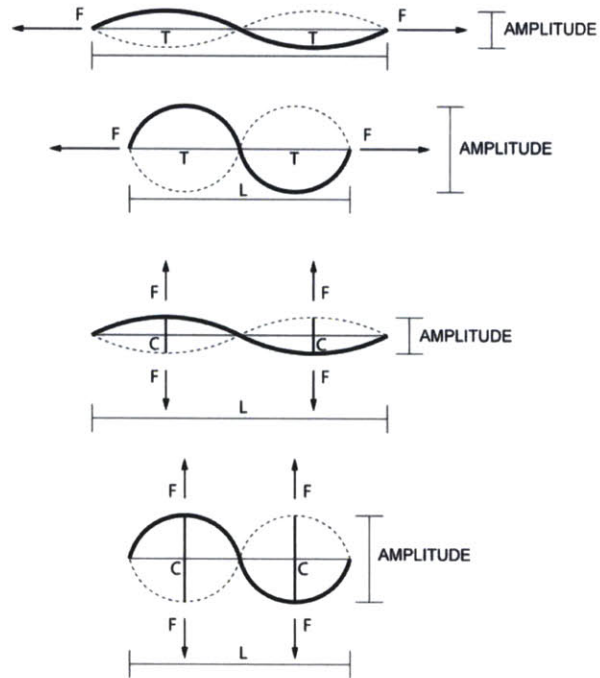
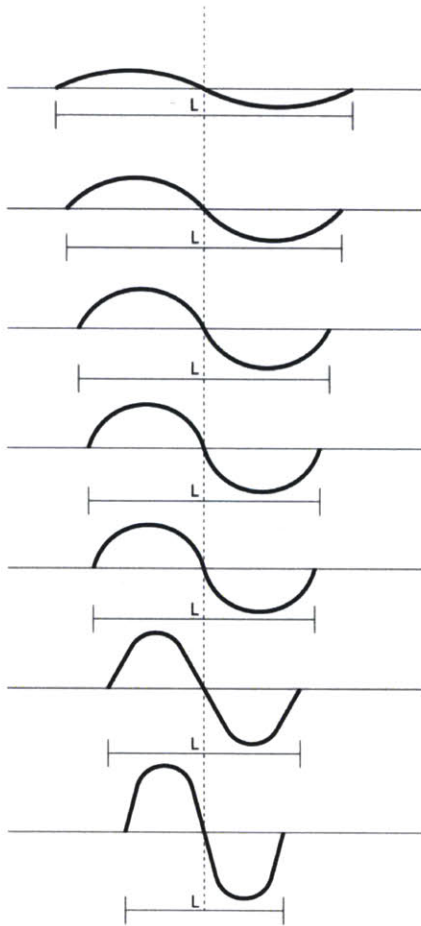

Image 15. Top: Wood shell in Sindelfingen. Right: Study model made of plastic strips and bolted at joints.

architects then constructed an assembly tower in the center of the grid, with a winch at the top to lift the shell with forces spread over different locations into the grid. The grid is finally lifted to a position higher than the rise of the shell (Gass p.7.20).

Although the paper and wood models of the previous studies behaved in a similar manner as the grid shell described, the woven system of the surface gave rigidity to the structure, and the friction among the members of the weave acted as joints. Therefore a new study was carried out with a small prototype of a grid made of plastic strips that were able to turn freely against one another at their intersections and held together by a series of steel bolts, much like the grid shell in Sindelfingen. The grid was manipulated in a variety of curved configurations and then the bolts were tightened in order to retain the shape. Instead of placing fixed points on the ground to keep



the base of the grid in place, a series of fishing wire tensor cables were placed at specific points of the grid to pull the edges together. A detail model was also created, where each individual element of the grid was composed of two strips bolted to one another, and separated at specific intervals by a compression element, giving higher strength to the grid shell.

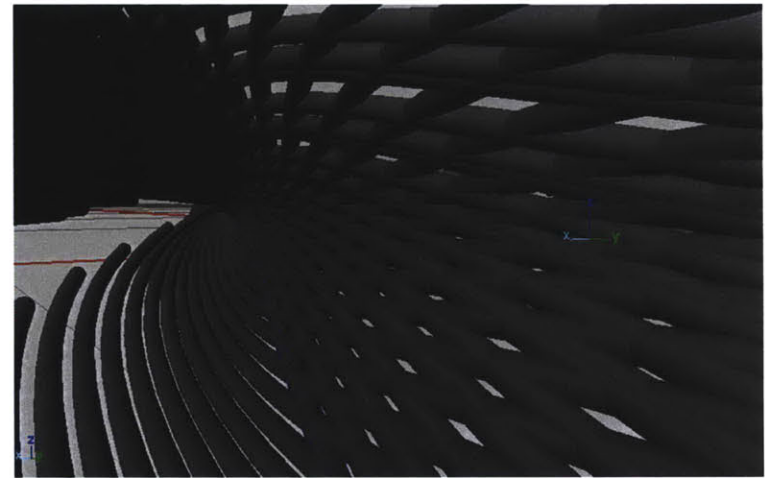
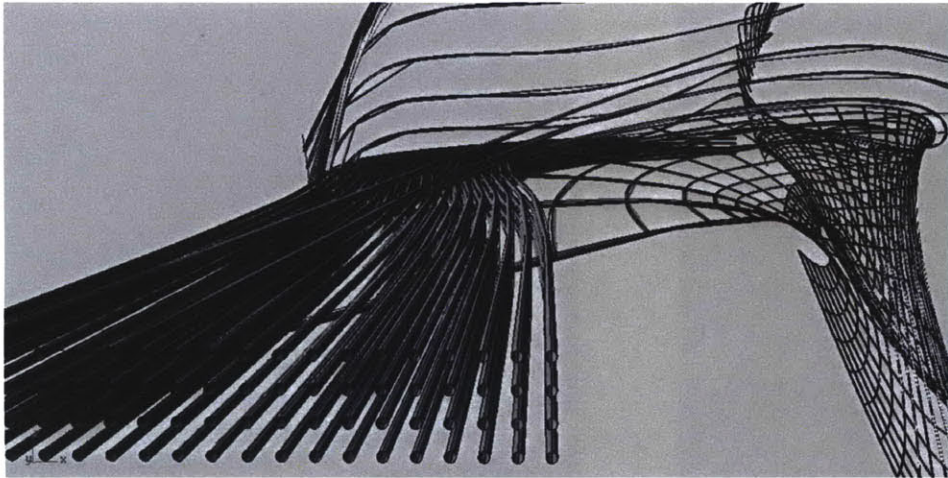

In order to digitally model these systems for further design, and to study the transition from one structural element to the other, such as the vertical support systems with the main enclosure, a series of studies were carried out where these variations could emerge out of the same system as branches from a tree. This allowed the system to be configured visually and structurally as a continuous system, instead of a system of assembled components of floors, columns and enclosure.

Although the first studies generated the desired continuity, their construction proved to be difficult due to the complex bending and torsion of the individual elements so that they could adapt to the transition from vertical (columns) to horizontal (floors) to curvature (surface). A second study was then carried out in which the overall surface was populated using a script written in MEL by Simon Greenwold from the Emergent Design Group at MIT called Weaver 1.0. Nevertheless, the script was initially developed to form a weave of strands of uniform diameter, based on the U and V parameters of the surface, which could intersect at points due to the thickness of the strands; whereas the system to be employed would have to be built not of intersecting elements, as in a

**Left: Detail model of structural system.
Right: Digital models and script-generated strands made with Weaver for Maya.**



welded steel framework, but of overlapping rods of varying diameter and manually tied at their joints. Also, since individual rods of bamboo vary greatly in diameter and length, it was decided to form a series of bundles that could also vary in their number of rods in order to support the necessary weight in specific sections of the structure. These bundles formed the main vertical members where a secondary bracing system of individual members strengthens the whole system. In order to tie the individual rods into close-packed bundles, while at the same time avoiding sliding among the members due to the pressure applied at the knots, a system of modules of seven rods was chosen as the basic structural bundle. This configuration formed a hexagonal symmetry between the surfaces of the cylinders in contact, and each bundle could then bifurcate into bundles of 3 and 4, which can be used for different structural requirements and flexibility within the surface. In

Images 16 and 17. Top: Roots in Rio de Janeiro and Tropical flora in Antigua Guatemala. The image shows the stemmg and branching networks.

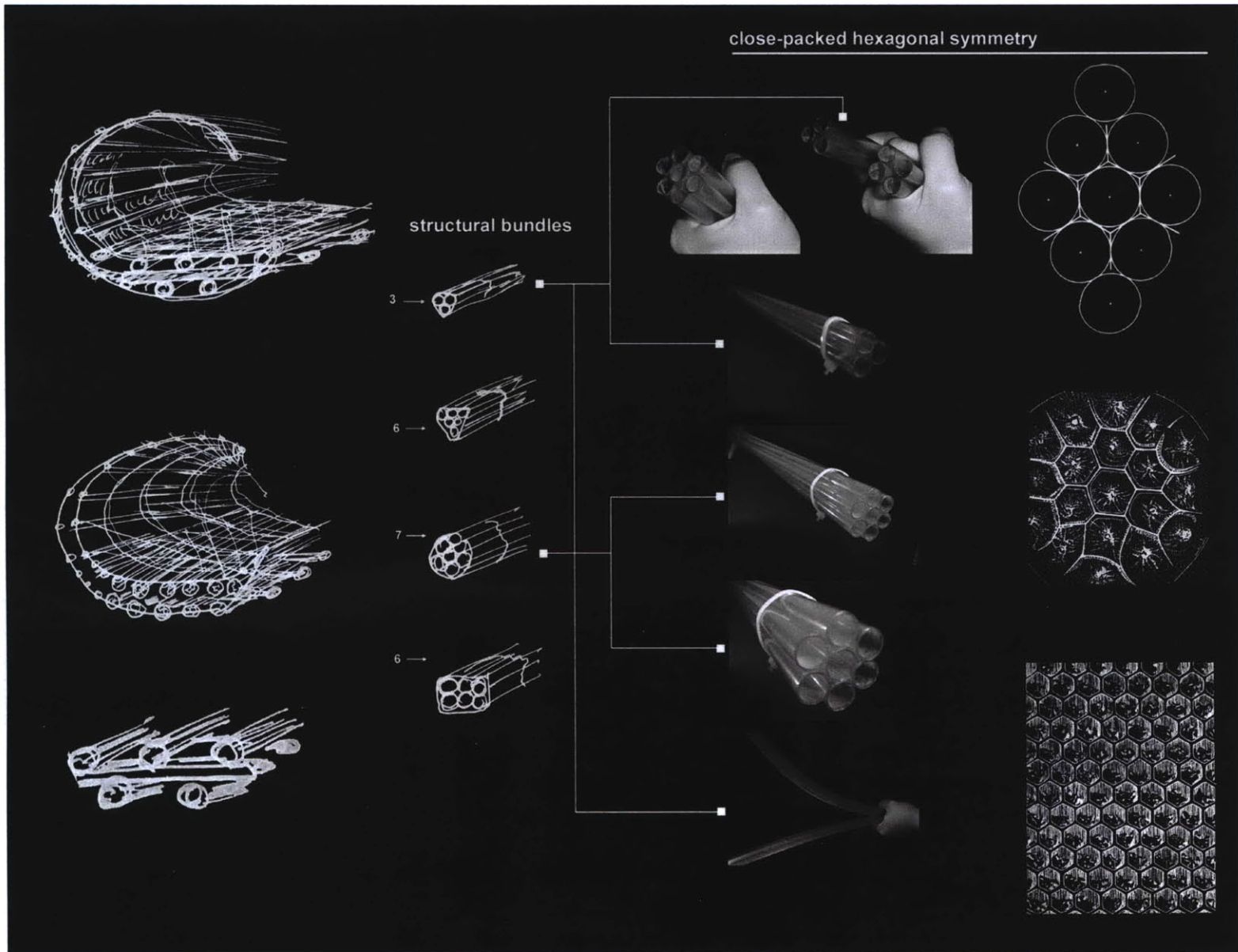

Sketches and studies of system of bundles in close packing and their branching possibilities. images 18-20. Right column: Hexagonal Symmetries.

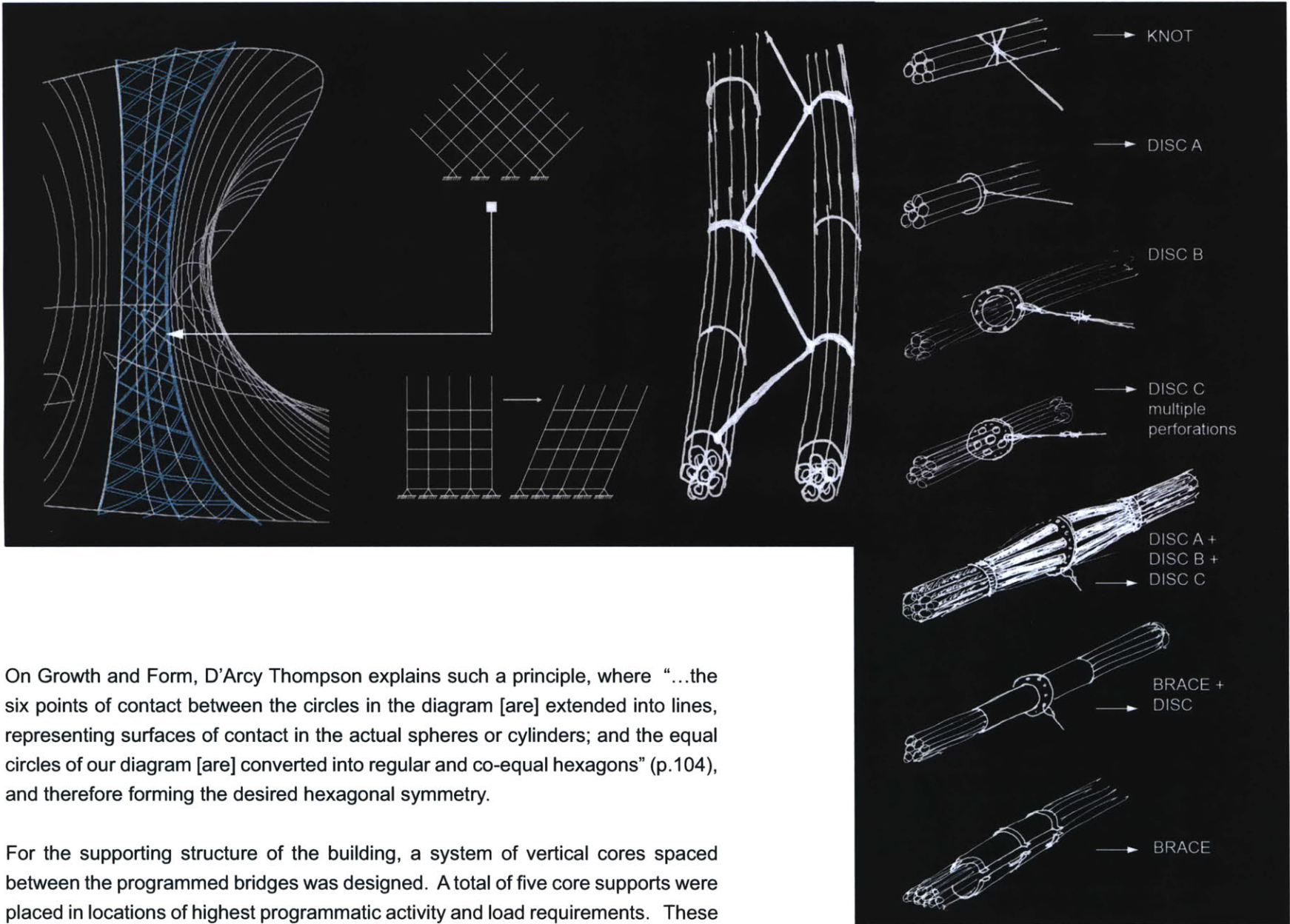

On Growth and Form, D'Arcy Thompson explains such a principle, where "...the six points of contact between the circles in the diagram [are] extended into lines, representing surfaces of contact in the actual spheres or cylinders; and the equal circles of our diagram [are] converted into regular and co-equal hexagons" (p.104), and therefore forming the desired hexagonal symmetry.

For the supporting structure of the building, a system of vertical cores spaced between the programmed bridges was designed. A total of five core supports were placed in locations of highest programmatic activity and load requirements. These

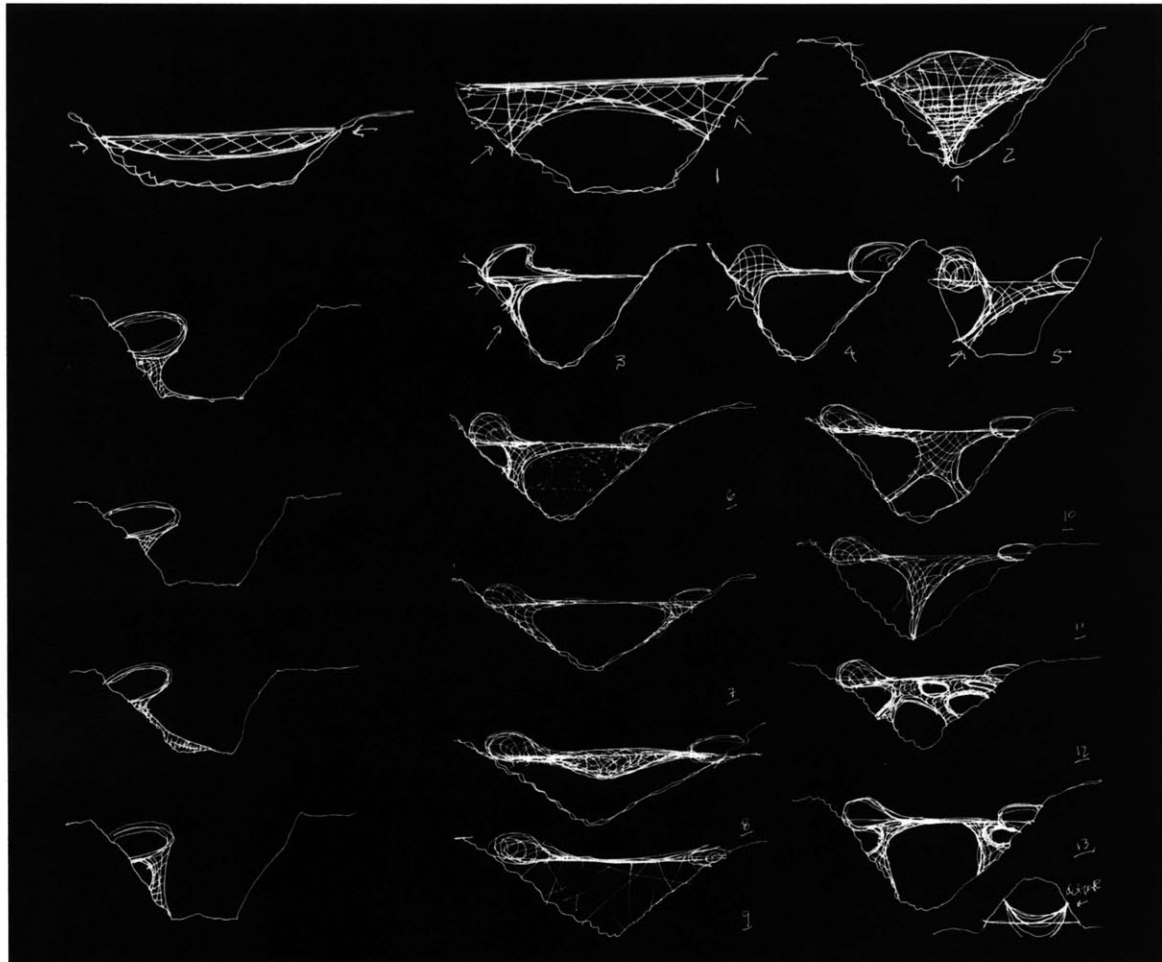

left: Studies of bundle systems, cross-bracing and knots. Right: Studies of possible design of structural supports in ravine.

vertical supports act as tree trunks with their base rooted on the variable slope of the ravine, while the top forms a branch-like system of rods intersecting with the structure of the individual decks and bridges as they blend into them. This allows for a series of joints and knots to be fastened with the horizontal structure along the bundles, providing more points of contact than a simple post and lintel system articulated at a single point. Additionally, the weight of the building is distributed over

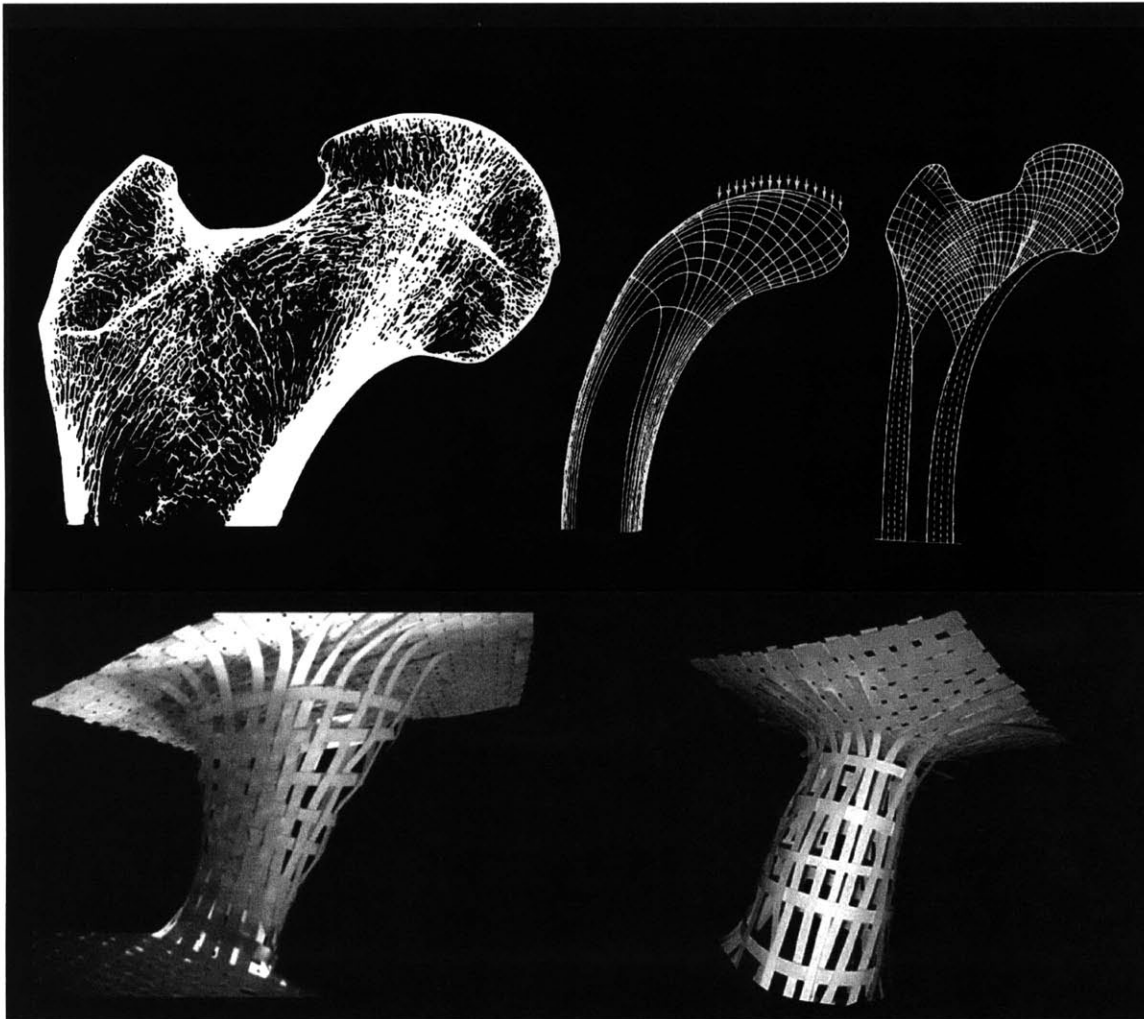

a larger area, in the same manner that bones support the weight of the body as "In the case of the tibia, [where] the bone is somewhat widened out above, and its hollow shaft is capped by an almost flattened roof, on which the weight of the body directly rests." (D'arcy Thompson, p. 230)

Image 21. Top: Lines of strength in human bone. Below: physical model studies for structural core

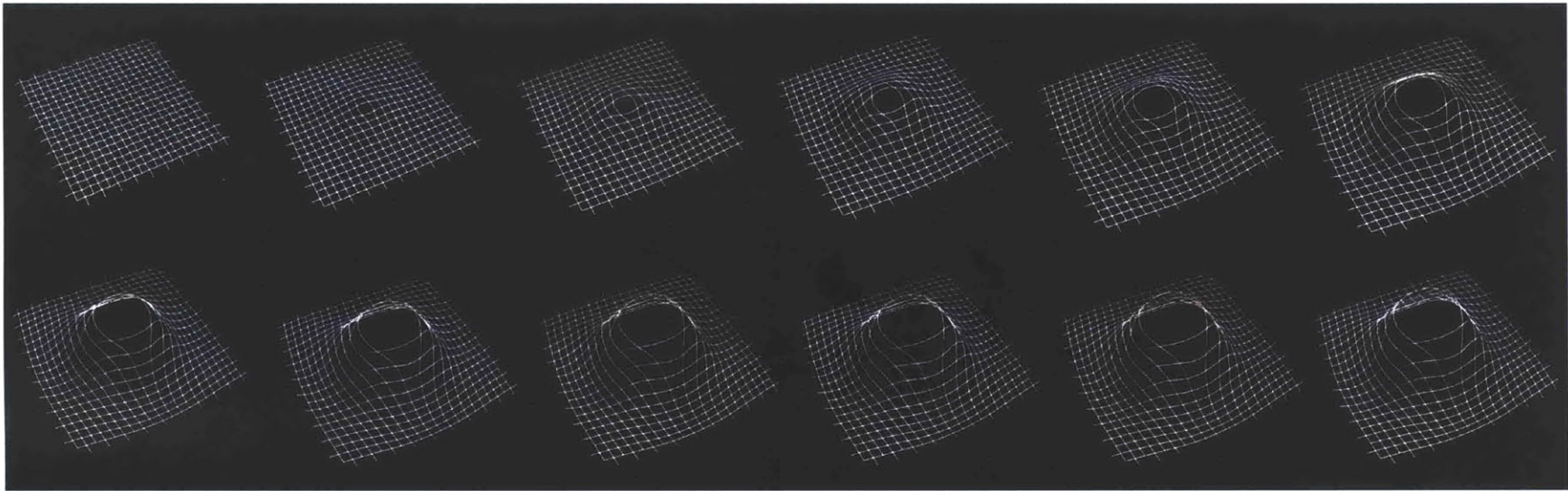
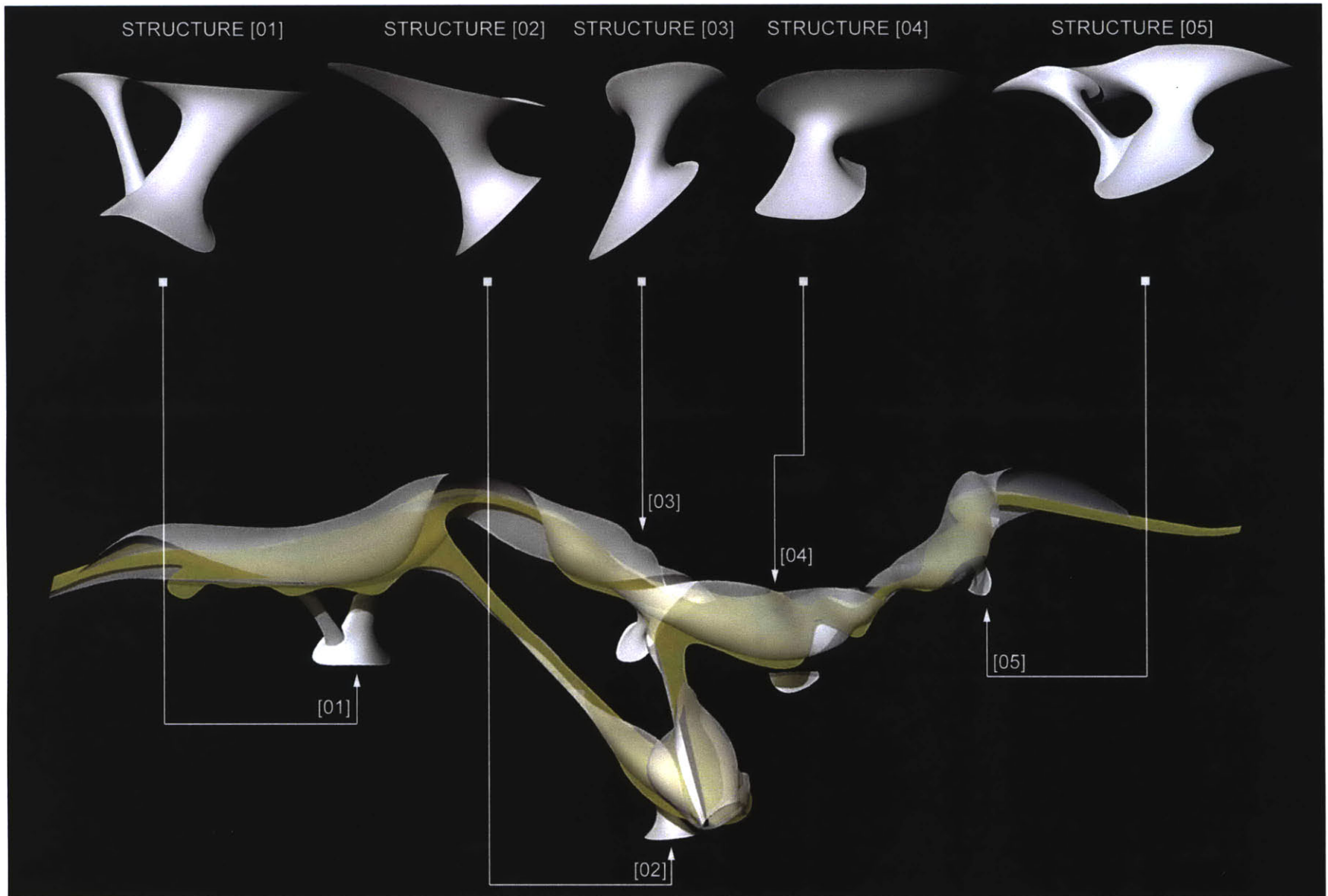
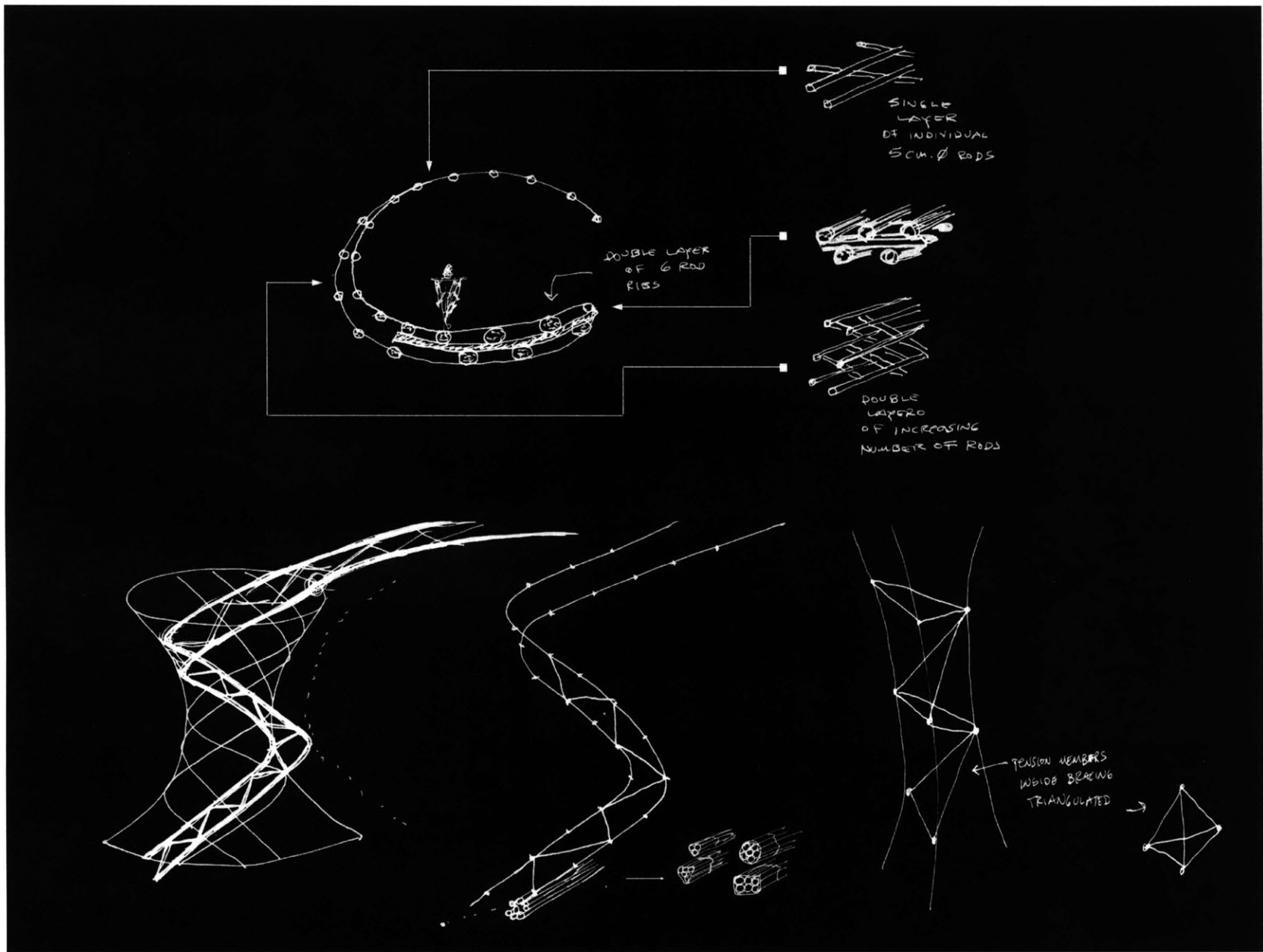

Image 22. Below: Peten rainforest in Guatemala. Top: Digital animation of 'branching'.

A digital model of emerging branches from a woven system was generated in order to study the possible configuration of each individual rod, as the system goes from a flat surface condition to the cylindrical or anticlastic curvature of the vertical support. A paper model of woven strips was developed to analyze the points of overlap from one condition to the other, while maintaining a network of vertical elements as directions of strength.



Left: Structural supports and their location in the building. Right: Studies of structure for the deck and structural supports.



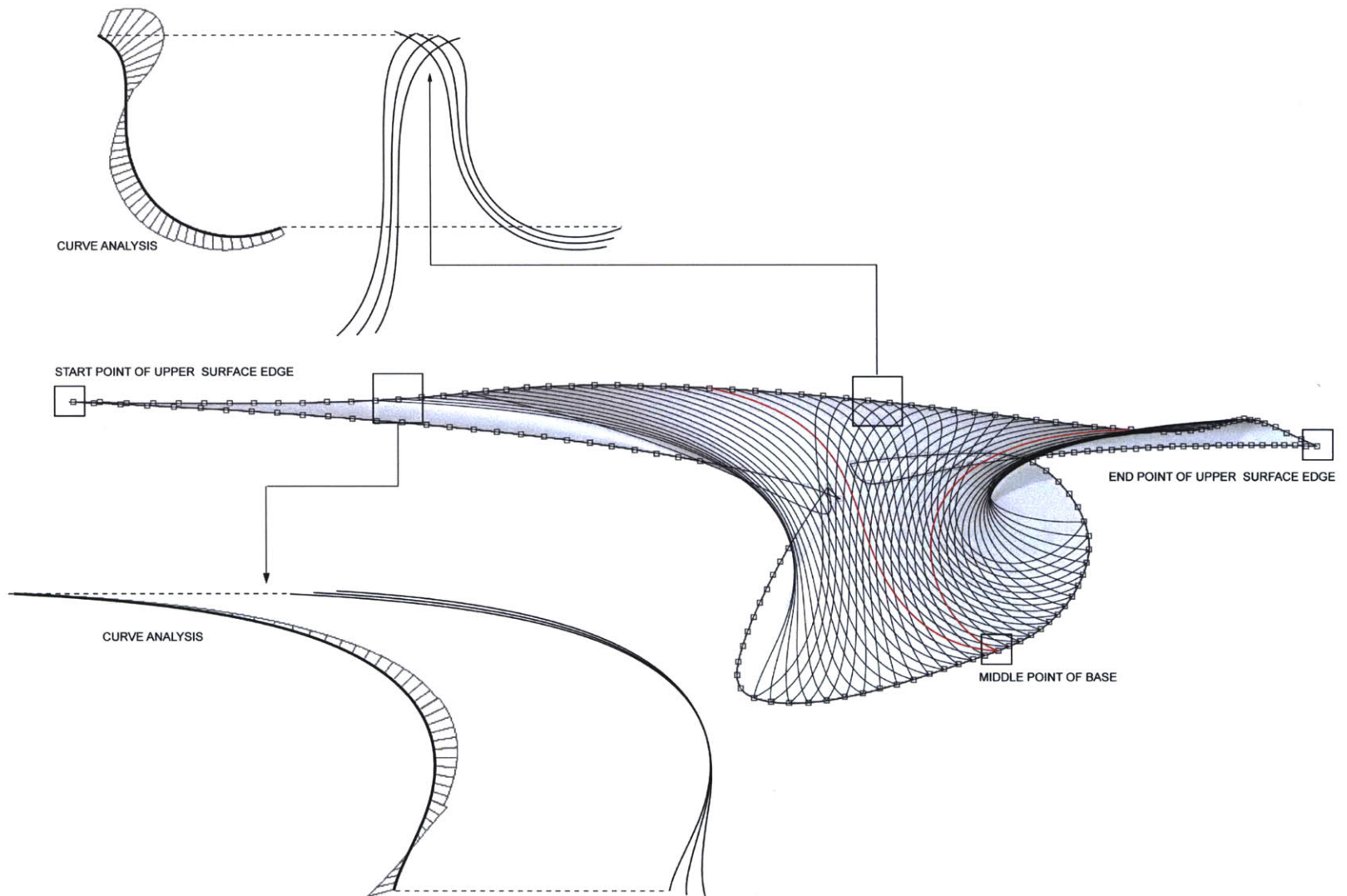

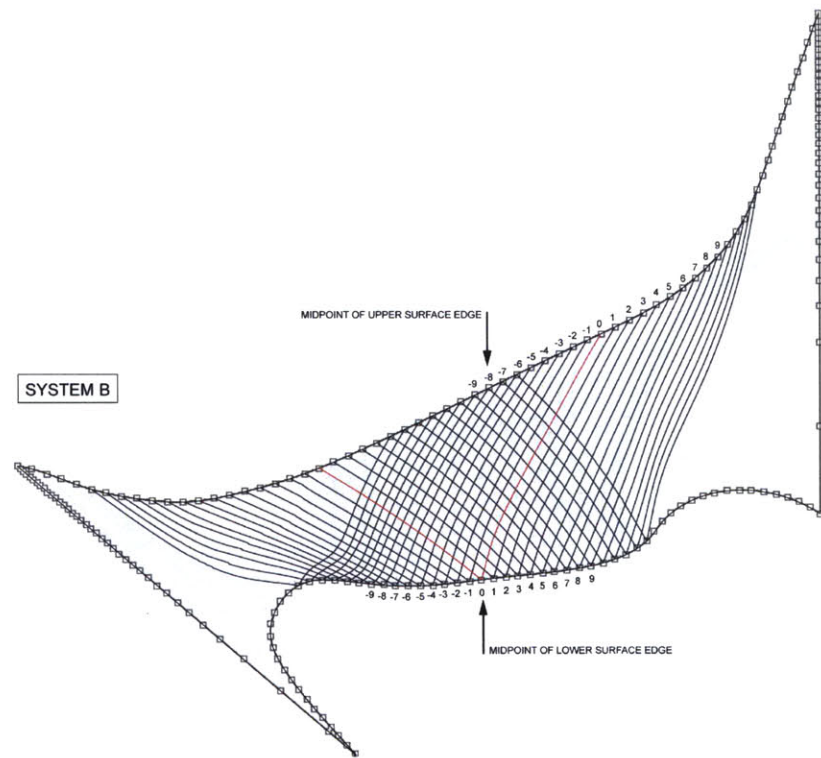
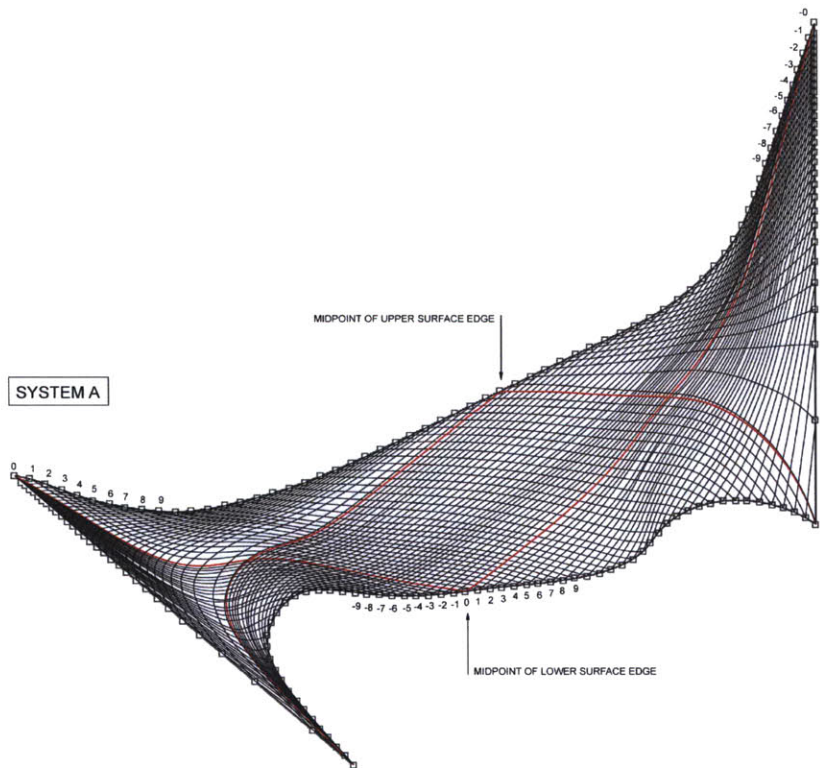

Digital models and diagrams of pattern analysis for rods in structural supports. Left: Structural support. Right: developable surface of structural support.

For the purpose of designing the pattern arrangement for each of these individual support systems or 'bones', a series of digital woven models were carried out and then unrolled into a flat surface to analyze the pattern of the different weaves and the curvature of the individual bamboo rods. After studying their curvature in different woven networks, a design was chosen where both rods and bundles run across the shortest possible distance from one end of the structural support to the other in order to minimize the number of overlapping members, while avoiding extreme bending as they adjust to the complex geometry.

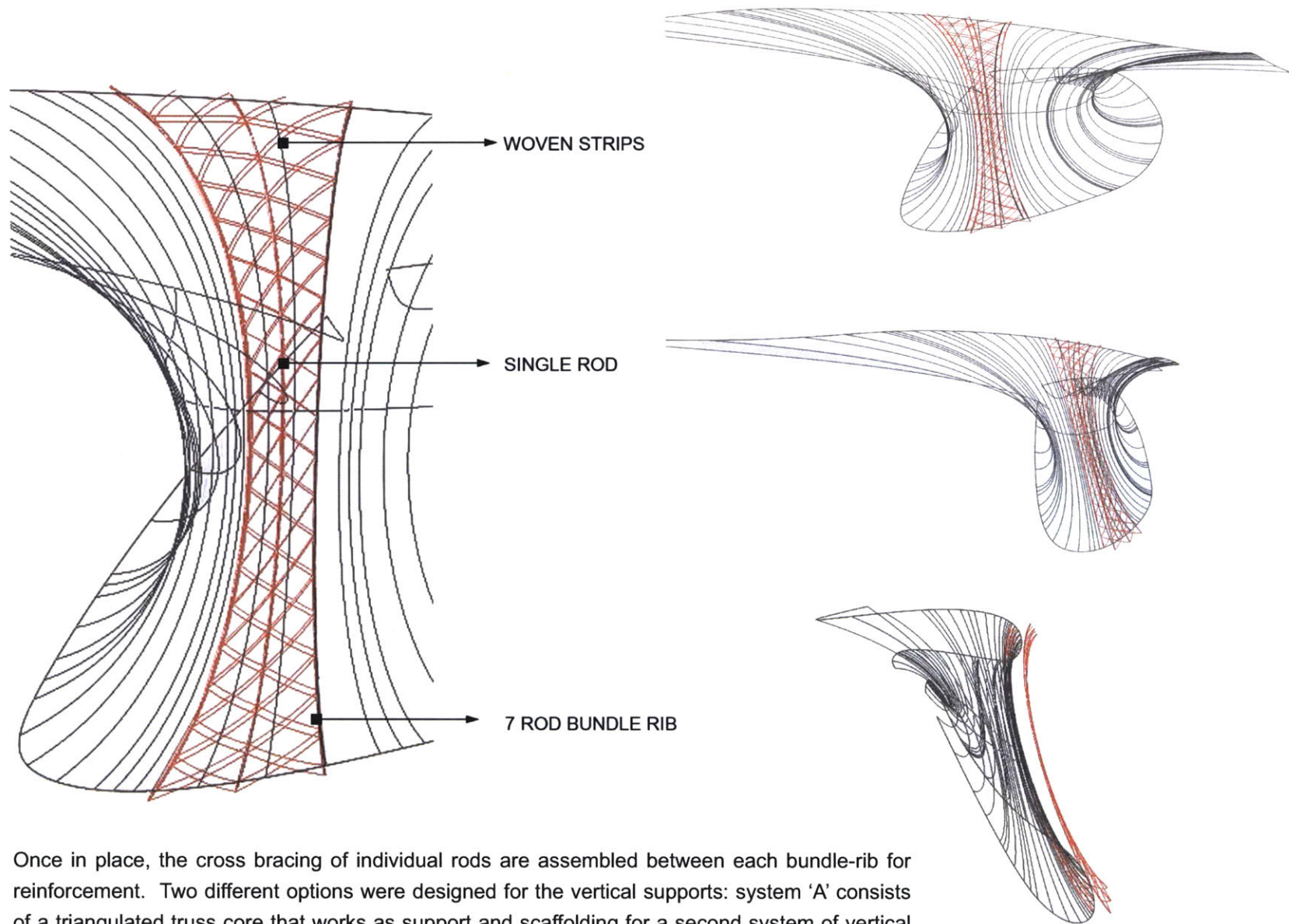

Once in place, the cross bracing of individual rods are assembled between each bundle-rib for reinforcement. Two different options were designed for the vertical supports: system 'A' consists of a triangulated truss core that works as support and scaffolding for a second system of vertical ribs to be curved against the core with the use of a winch. After they have been reinforced with

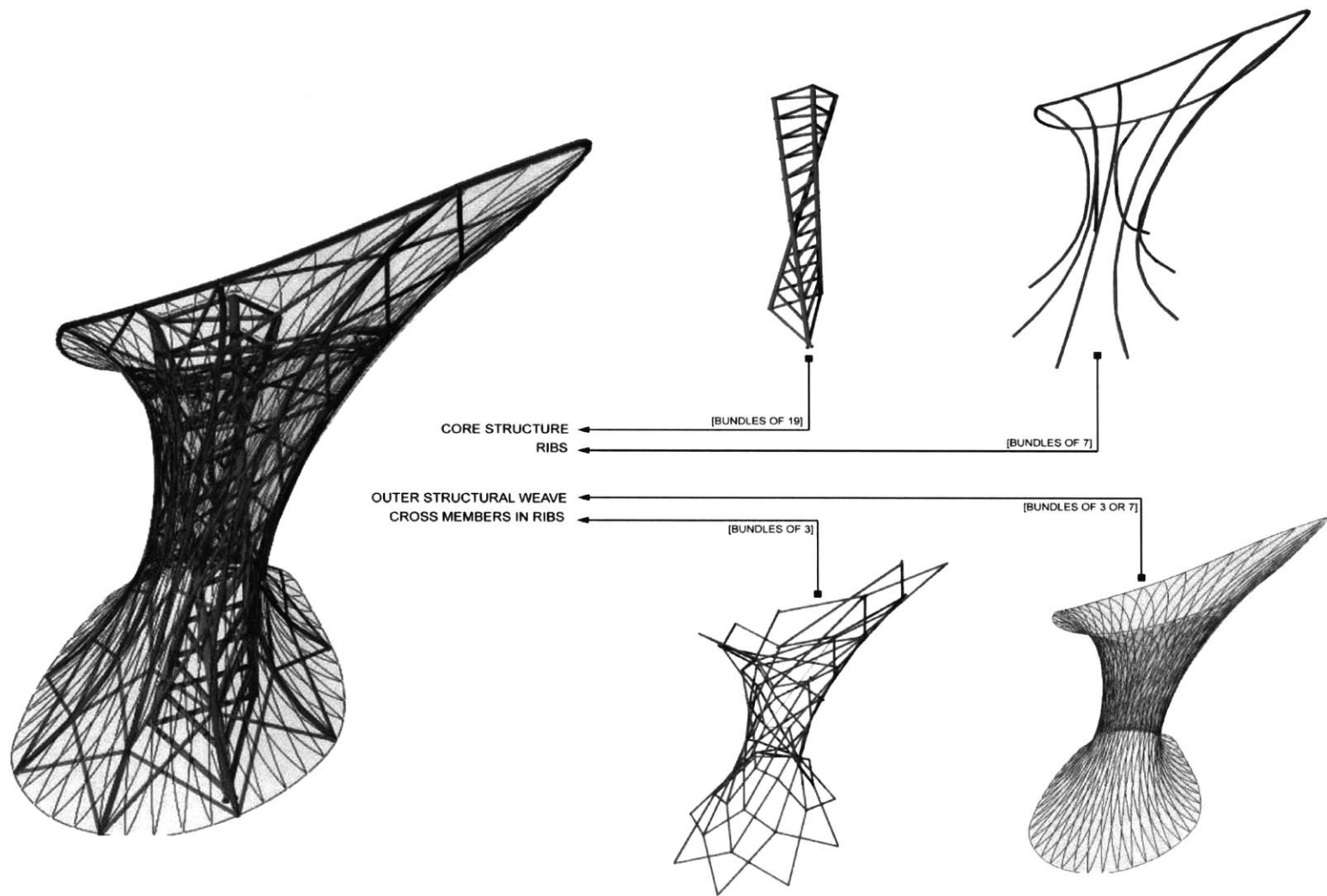

Structural assembly and cross-bracing between curved bundles. System 'A'

cross bracing elements, a third outer structural weave of single elements completes the supporting system. System 'B' works similarly except on the inside, where instead of a triangulated truss, the same outer system of cross-braced rods is constructed.

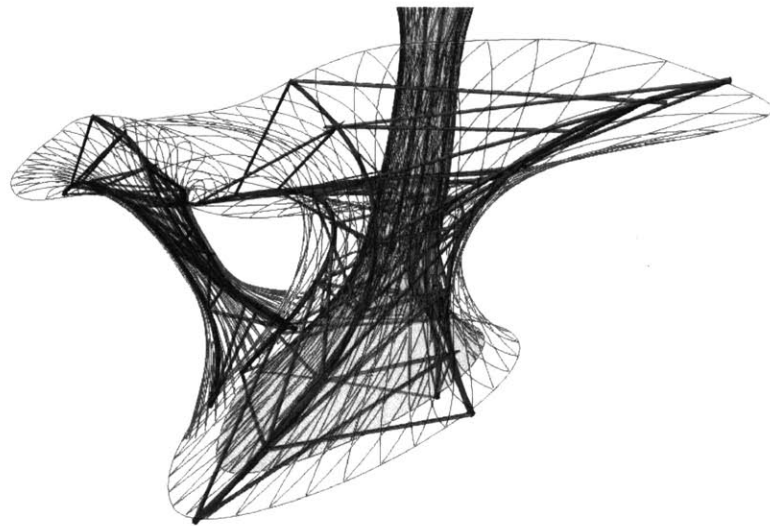
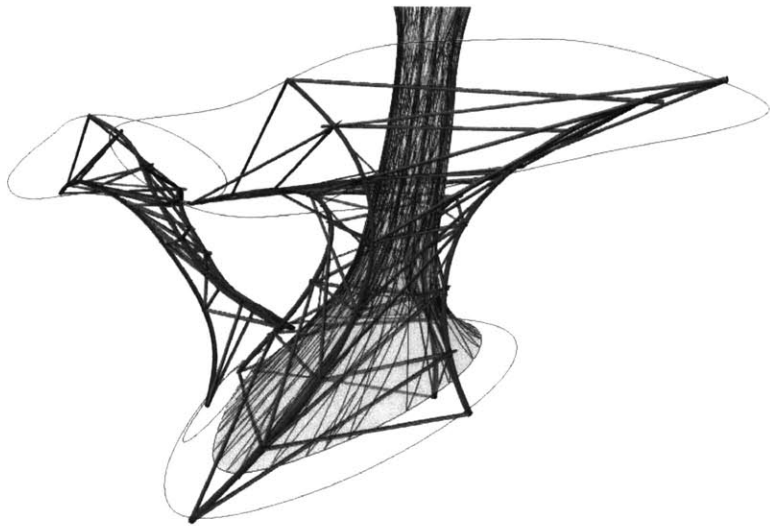
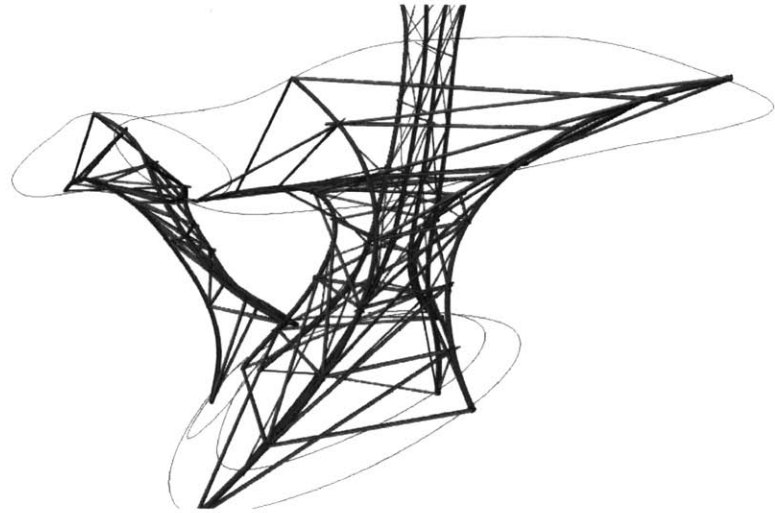
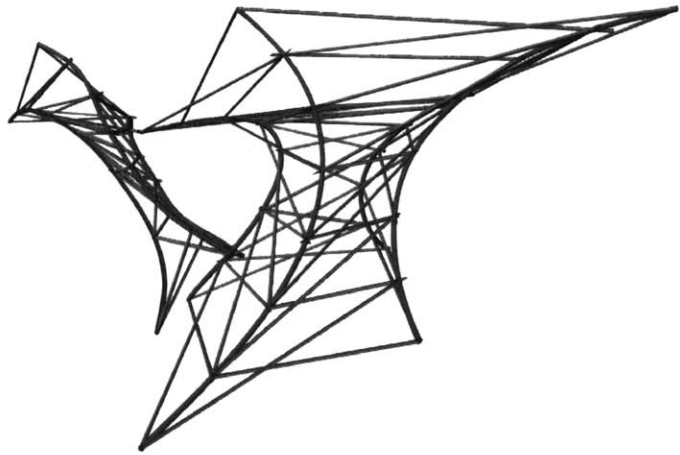



metacarpal bone - vulture's wing

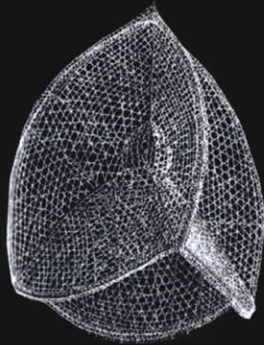

nassellarian skeleton

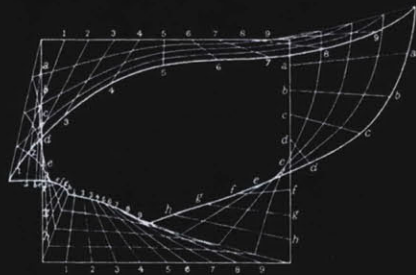

rectangular coordinate network (pelvis)
from D'arcy Thompson's *On Growth and Form*



BIFURCATED STRUCTURAL ELEMENT

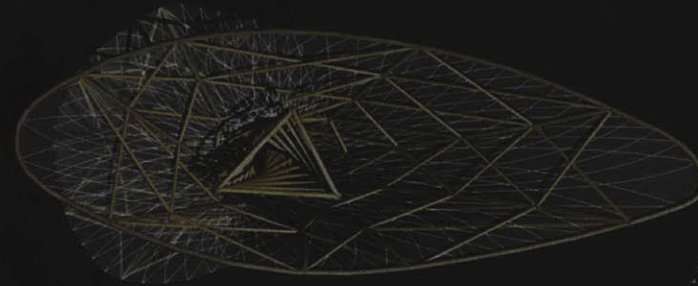

BUNDLE VARIATION



UNFOLDED WEAVING NETWORK

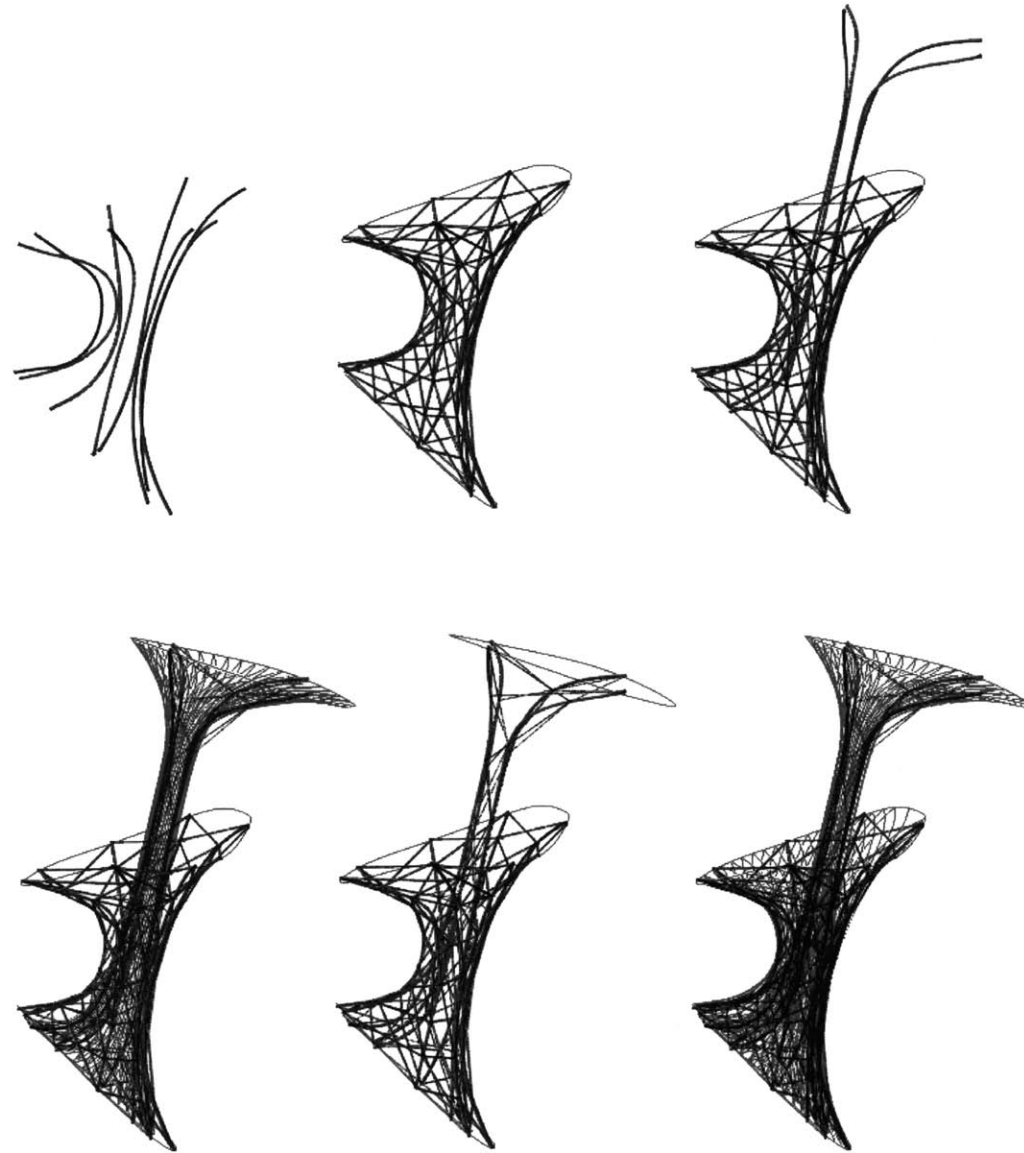

Sequence of assembly of double core supports.

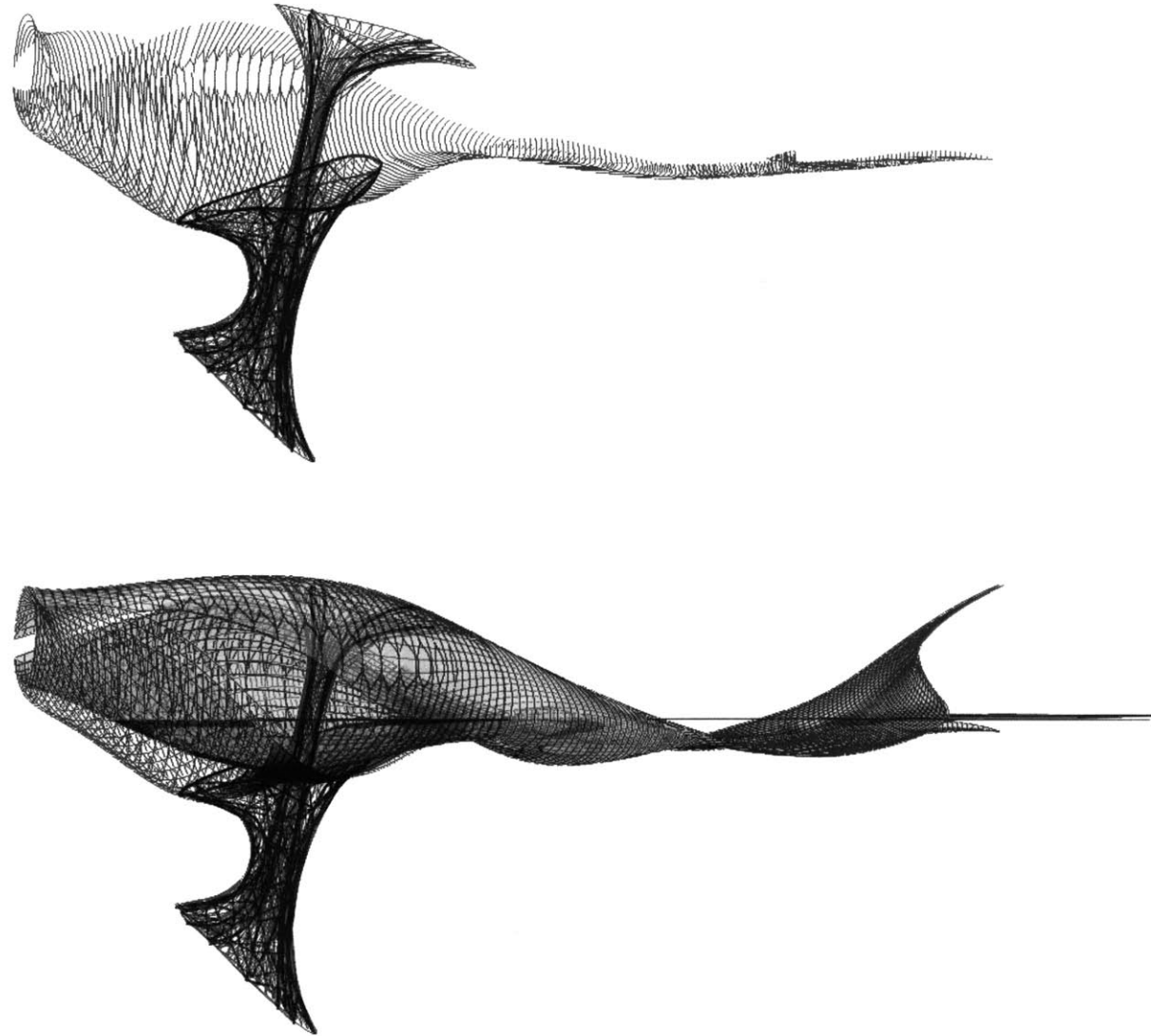

Double core support and surface pattern of bamboo enclosure in greenhouse



View from below showing location of structural supports

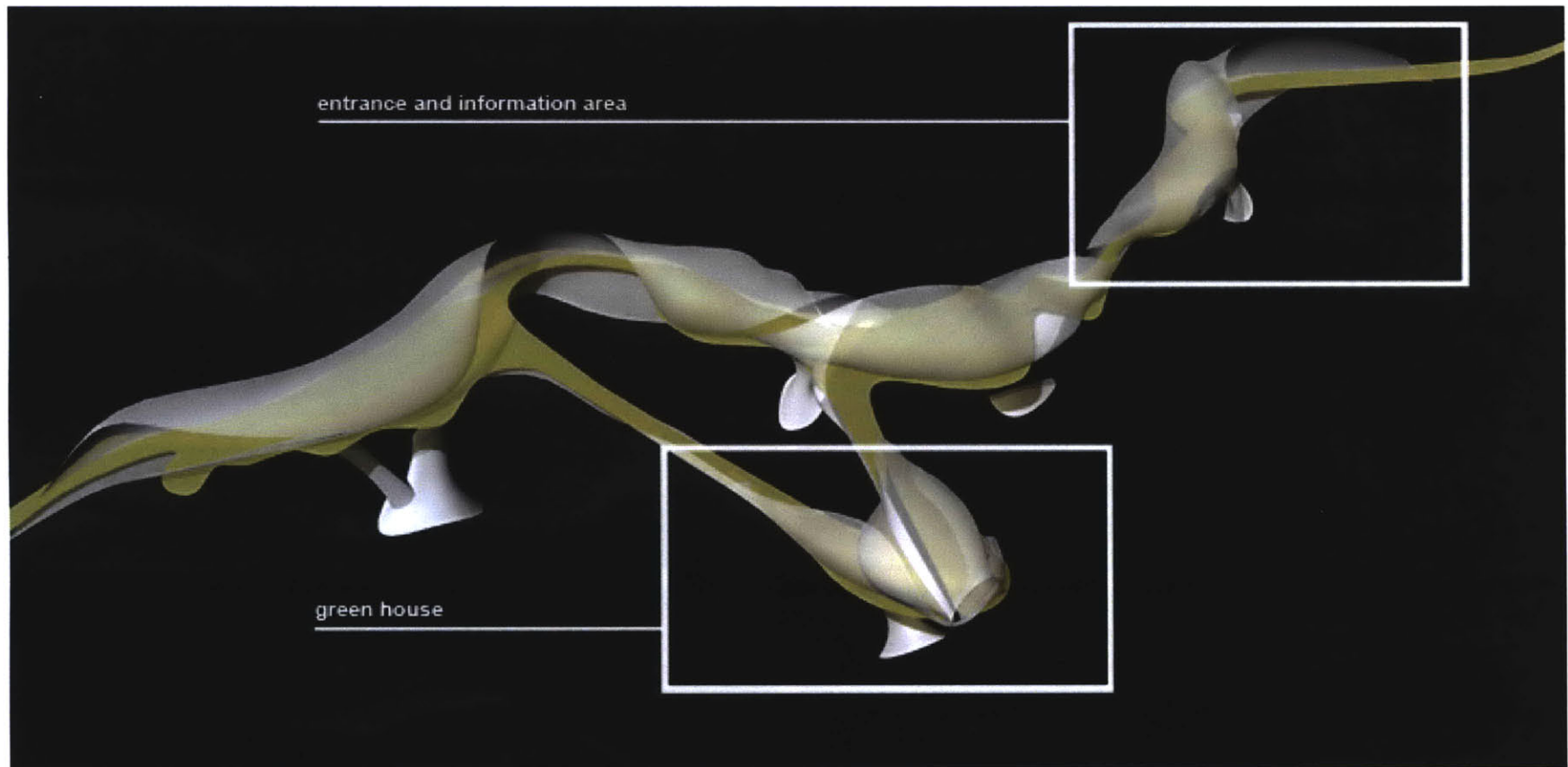

Wrapping surface adjusted to different programmatic, structural, and permeability requirements. The sections designed in detail are framed

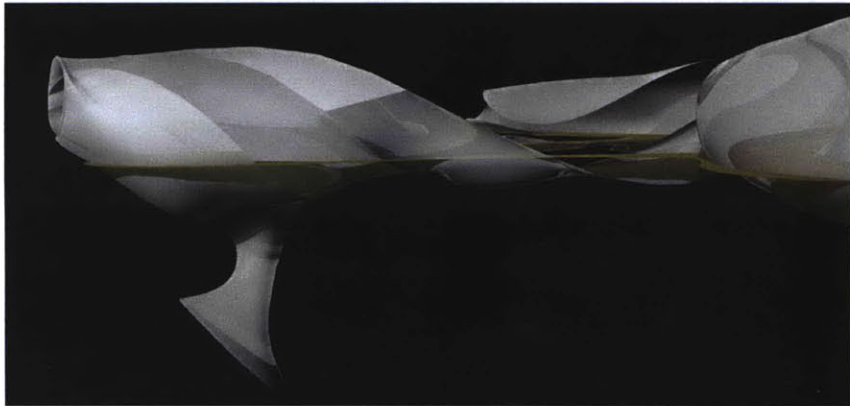
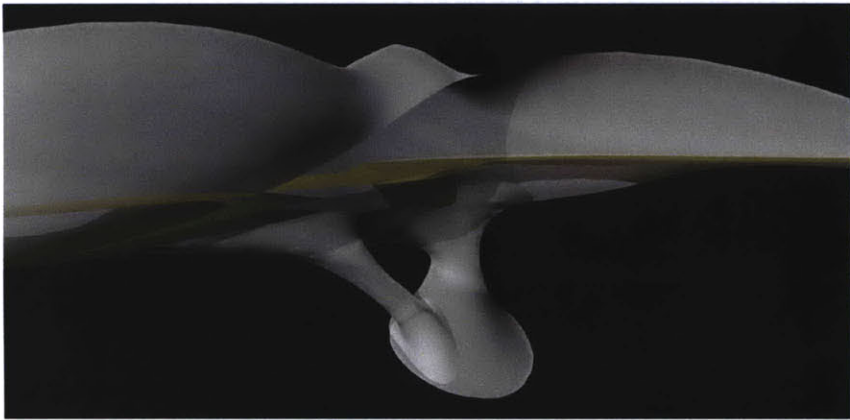
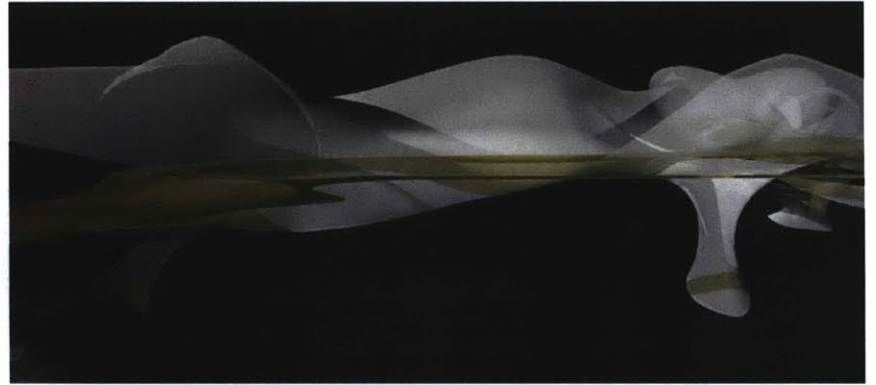
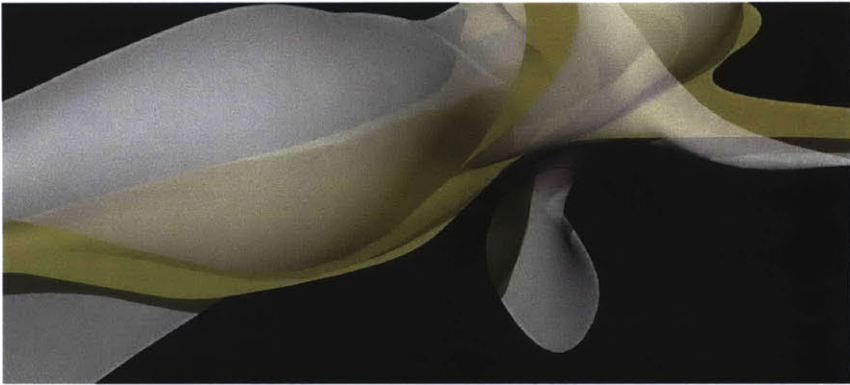

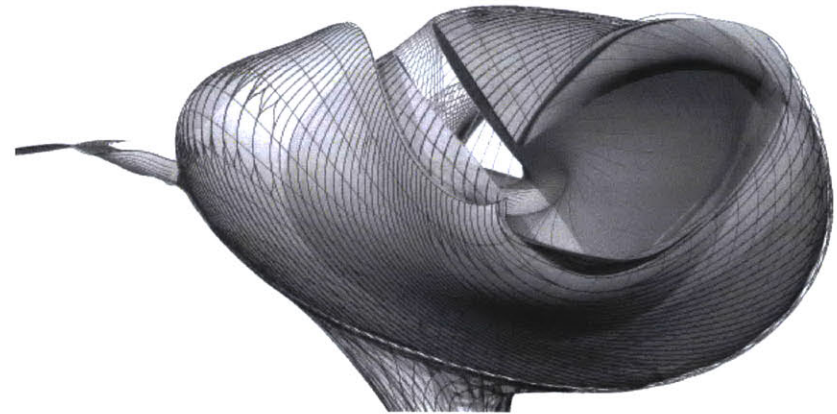
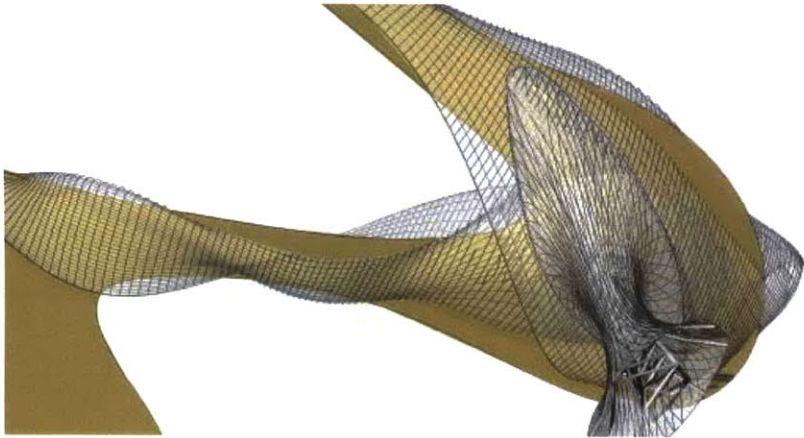
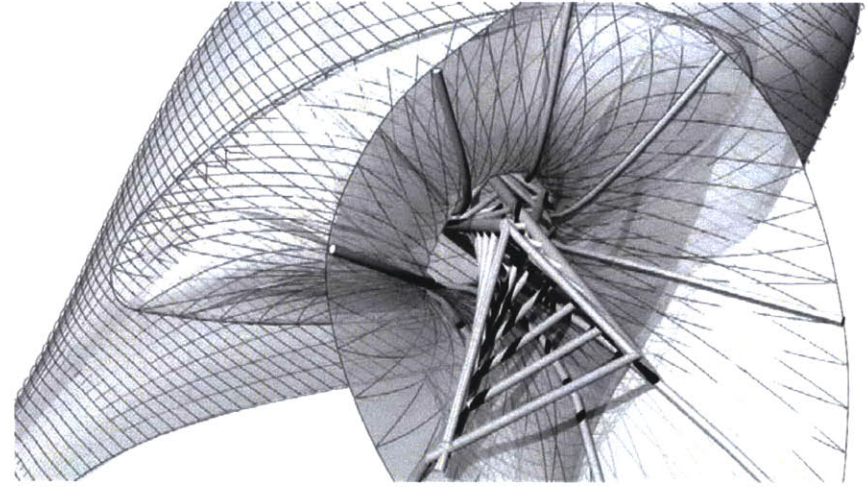
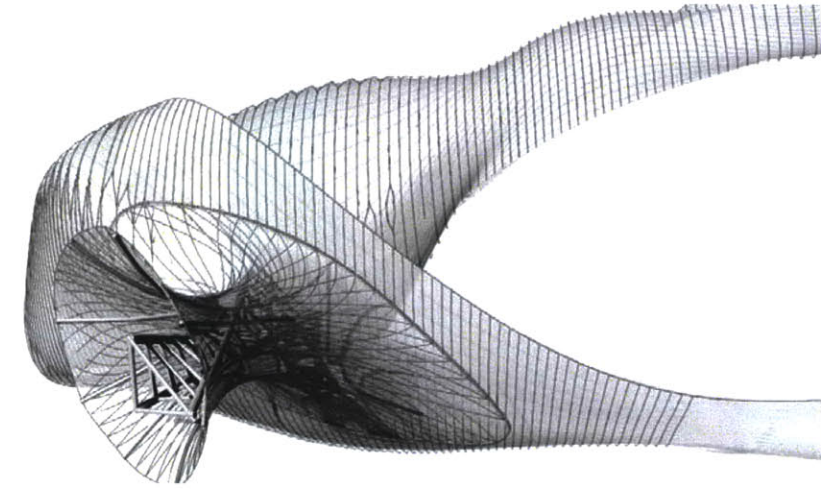

Left: views of building following the geometry of the topography.
Right: double core support and surface pattern of bamboo enclosure in greenhouse

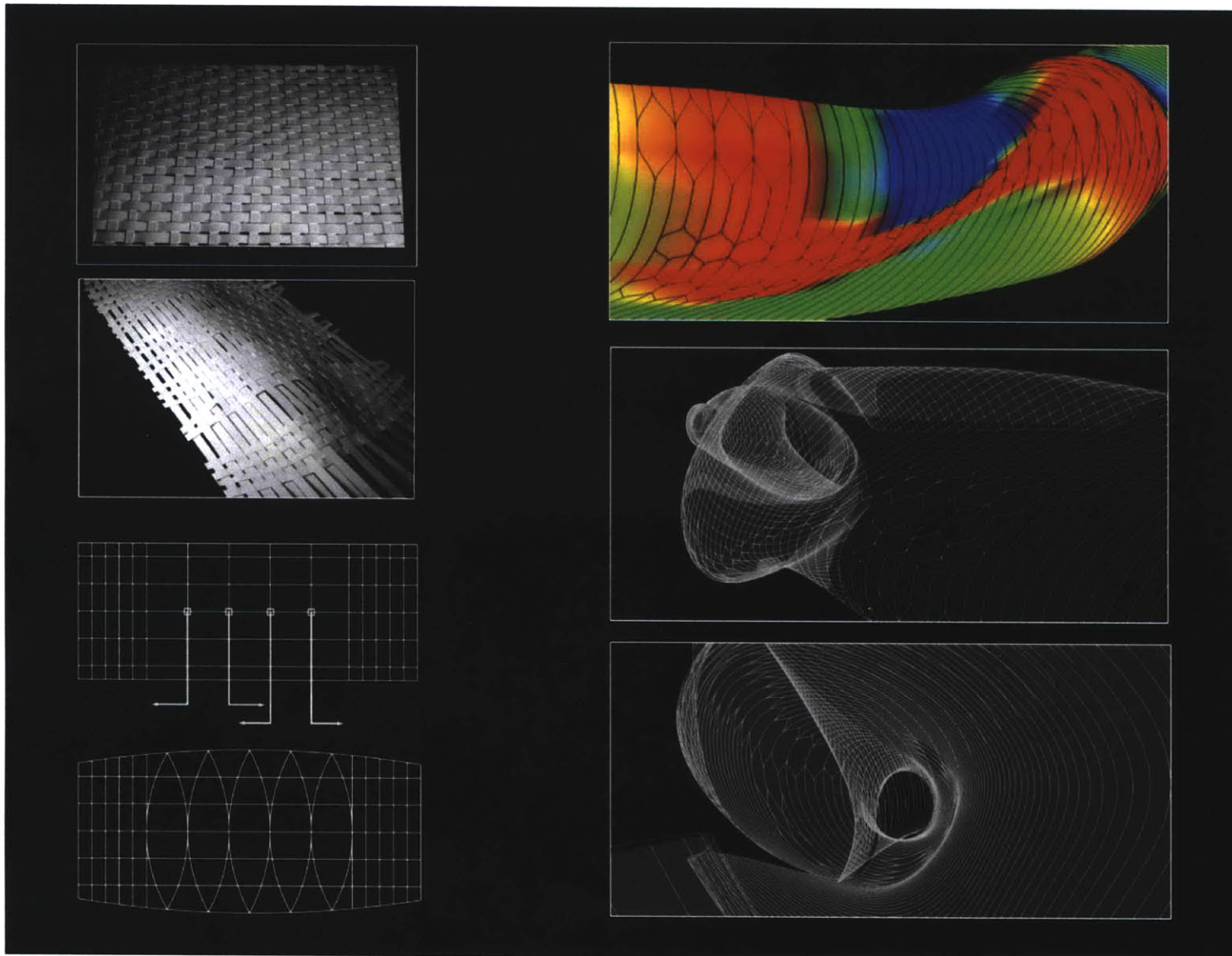

Double curvature patterns woven in variable areas. The surface analysis indicates the location of the specific pattern

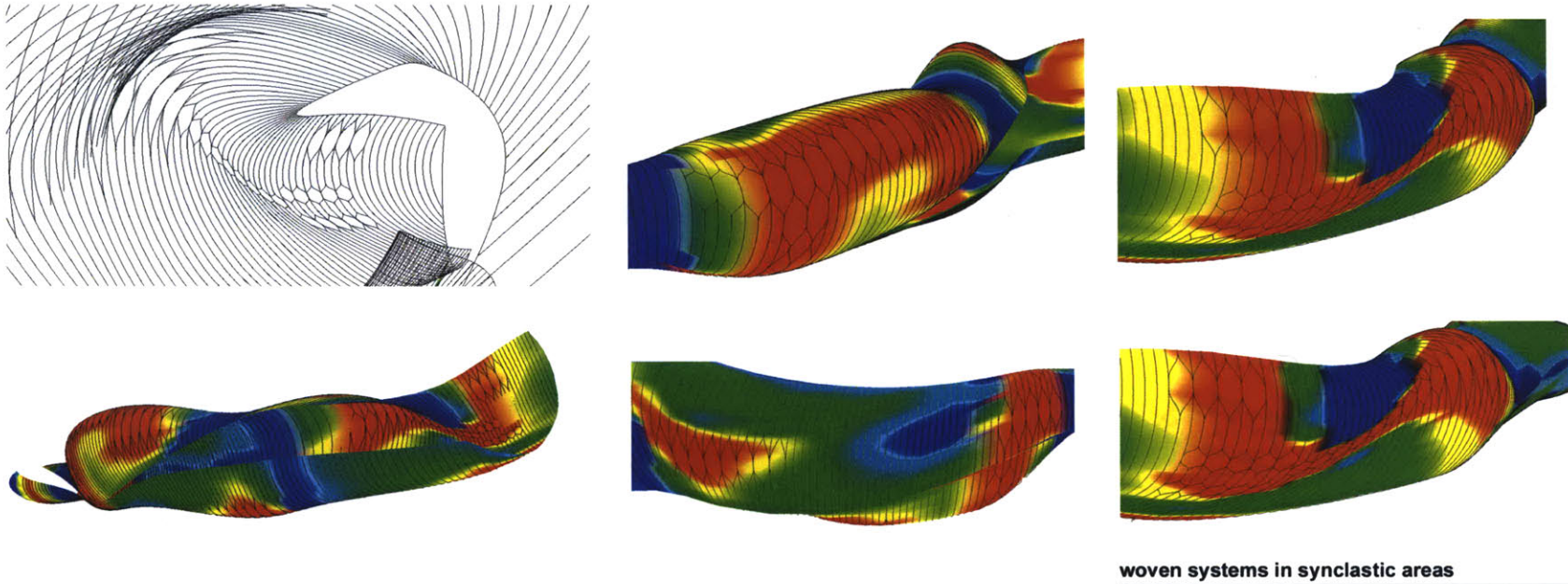

6. FITTED SEAMS

In order to design the specific configuration and pattern transitions of the woven networks to conform to the different types of curvature in the building, the digital model was subdivided into sections and a second series of surface analysis were carried out. Once the specific locations of the different curvatures were located, a physical model of plain weave was developed, but instead of generating the surface curvatures from one single system of elements as in the previous studies, the pattern was subdivided into smaller sections of double curvature where it was needed, which allowed the patches of the surface to be assembled by smaller elements and therefore facilitating its construction. Because each element to be bent was shorter in length, the pattern to be assembled is easier to manipulate and adds rigidity to the enclosure as they are bent individually, instead of having one single rod bent at a larger distance. These patterns of variable density were re-designed on the digital model and at specific points using the curvature analysis as a guide.

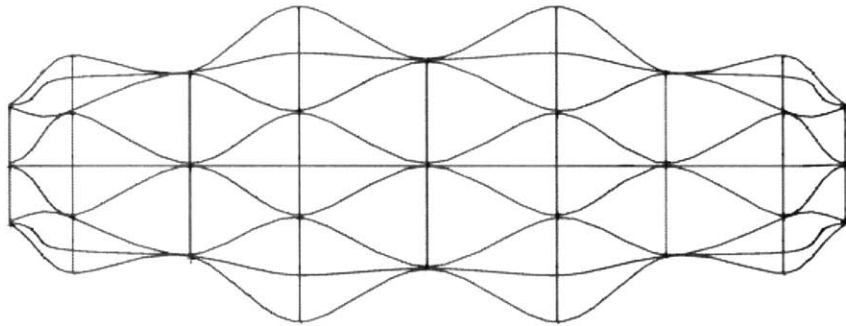
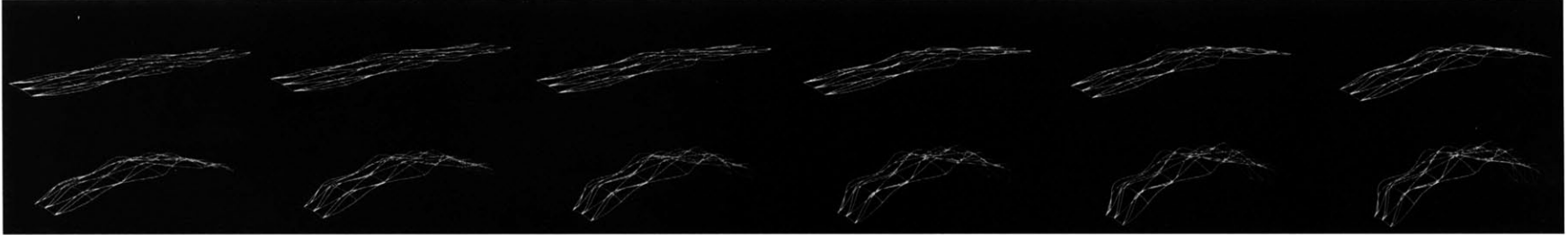

A final physical prototype at scale was developed with individual nylon rods and tied at their intersections with plastic ties, simulating an approximation of the construction system to be employed in the building made of bamboo. Different surface curvatures of enclosure possibilities were produced with one single model by pulling and sliding the elements into different patterns, which could adapt to the different structural, formal, and permeability requirements of the design. Once a pattern was chosen to produce a specific curvature for the enclosure, the knots were fastened into their final position with the plastic ties.

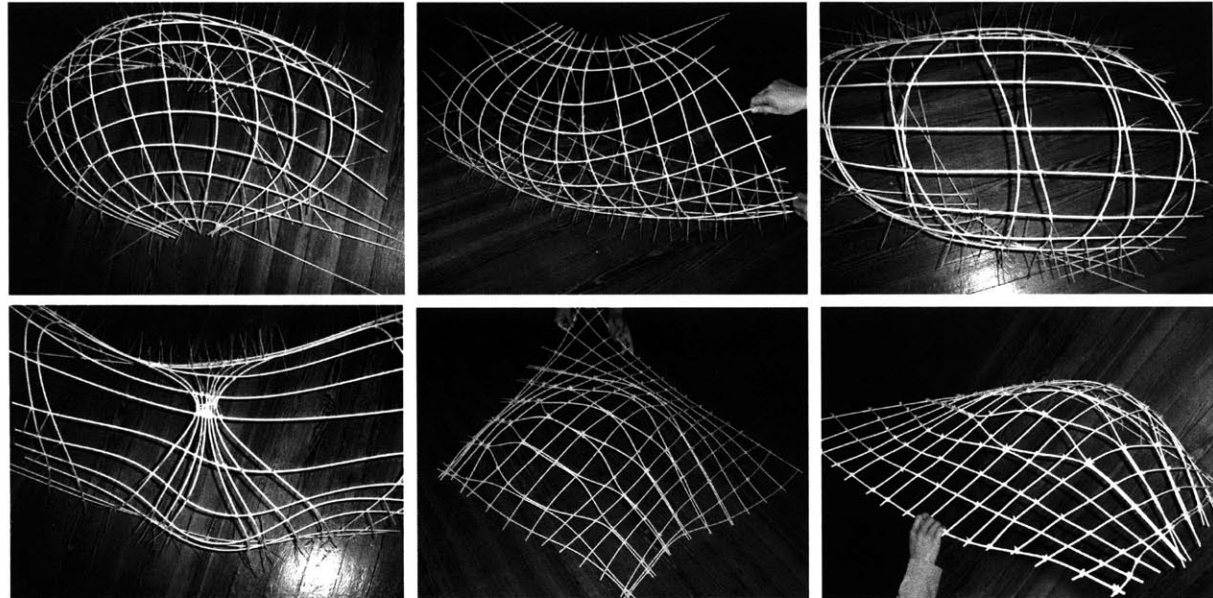
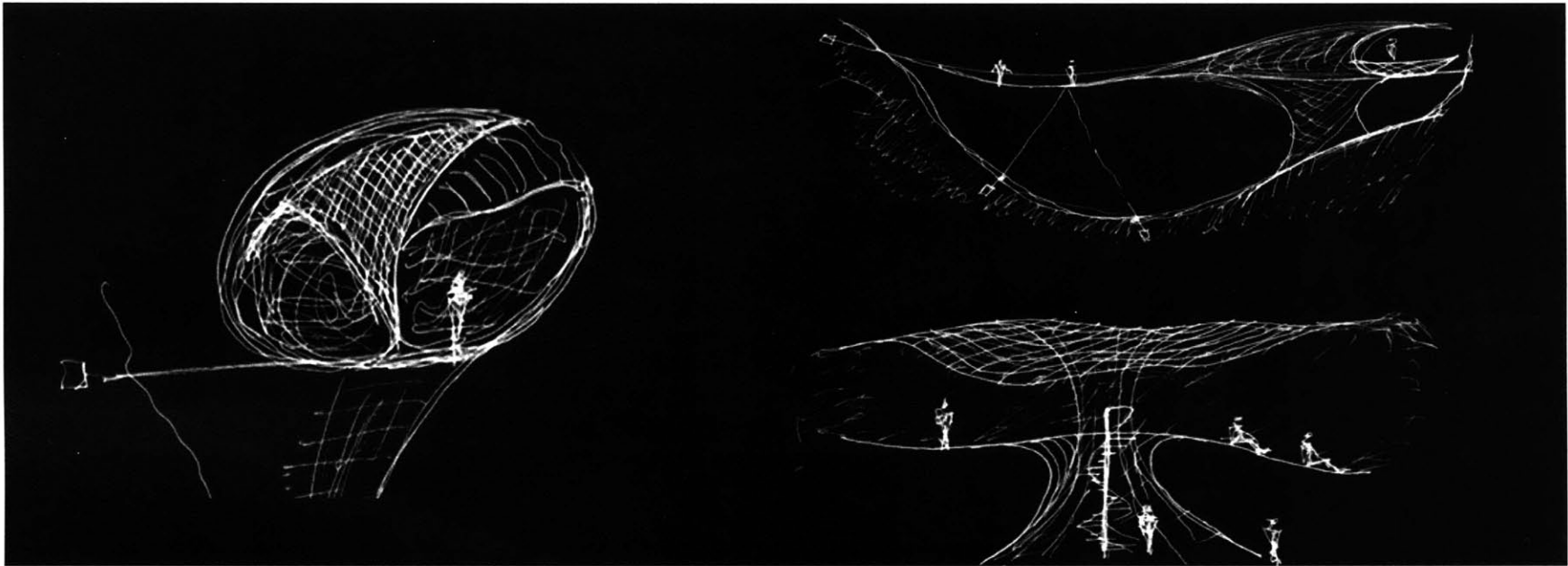

Left: Digital model and animation of surface from flat to curved as the pattern is manipulated. Top: sketches of types of cf occupation in building. Right: Different patterns on a single model made of nylon rods. The patterns generate different formal possibilities.

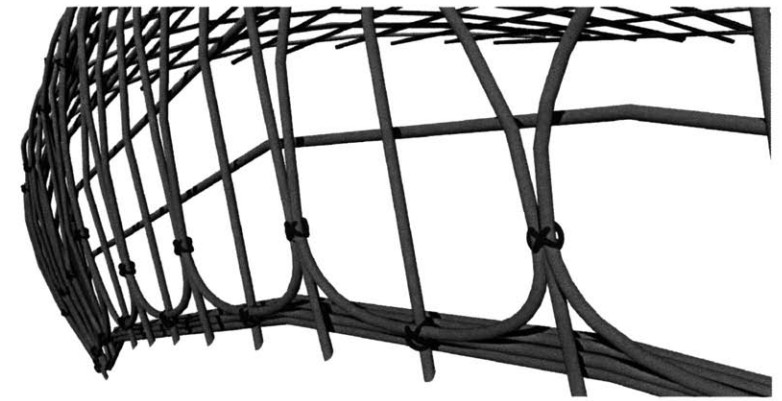
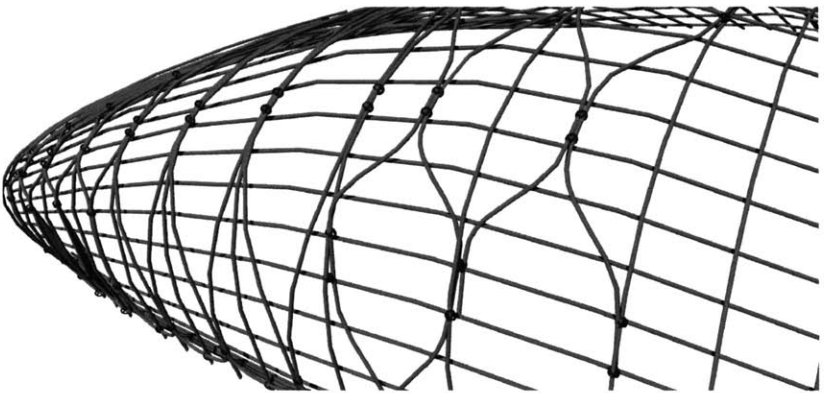
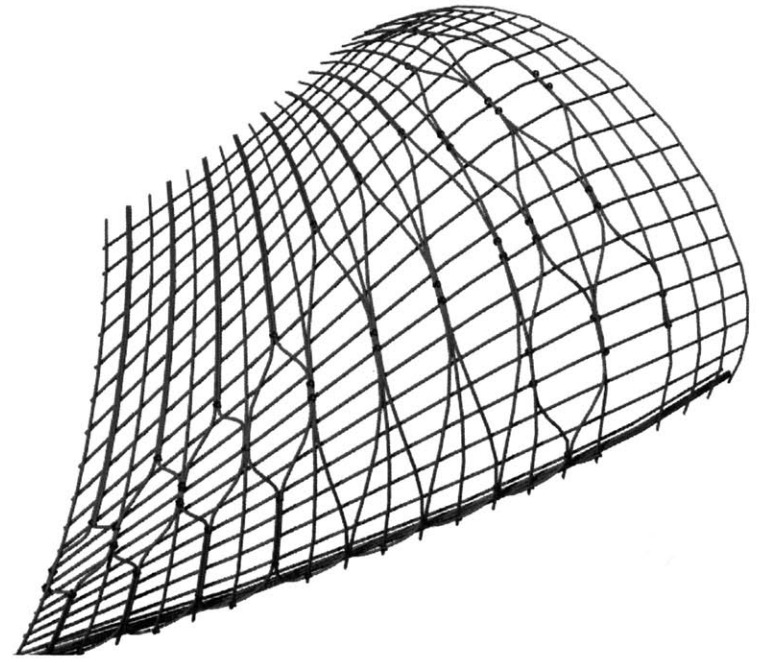
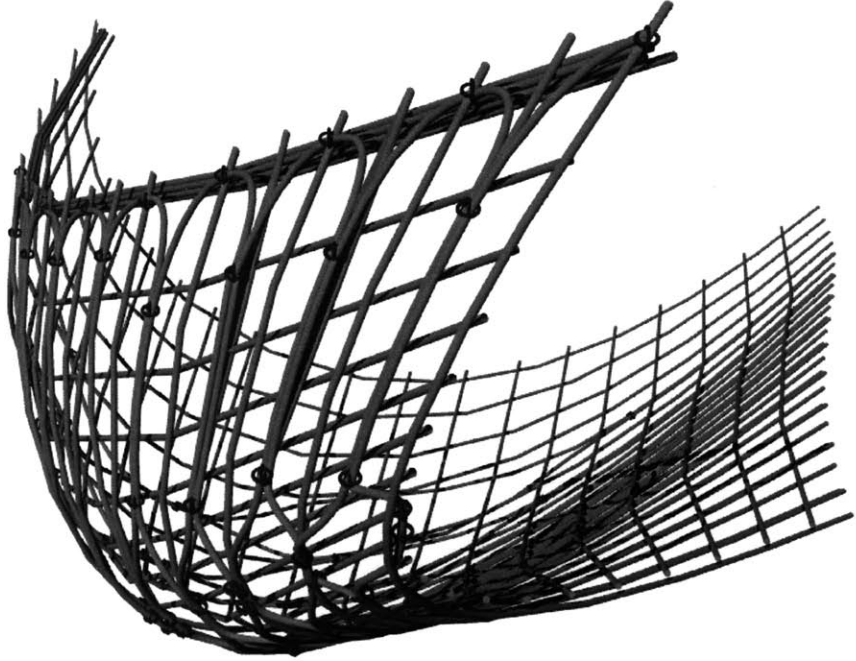



Left: Woven network of rods on building surface and pattern of assembly. Right: detailed studies of assembly of different structural elements

7. SKIN AND STEM STRUCTURE

A similar system for the creation of trusses was achieved by bending some elements between bundles in order to become a single structural piece. In order to keep the close packing configuration, additional smaller bamboo segments are introduced.

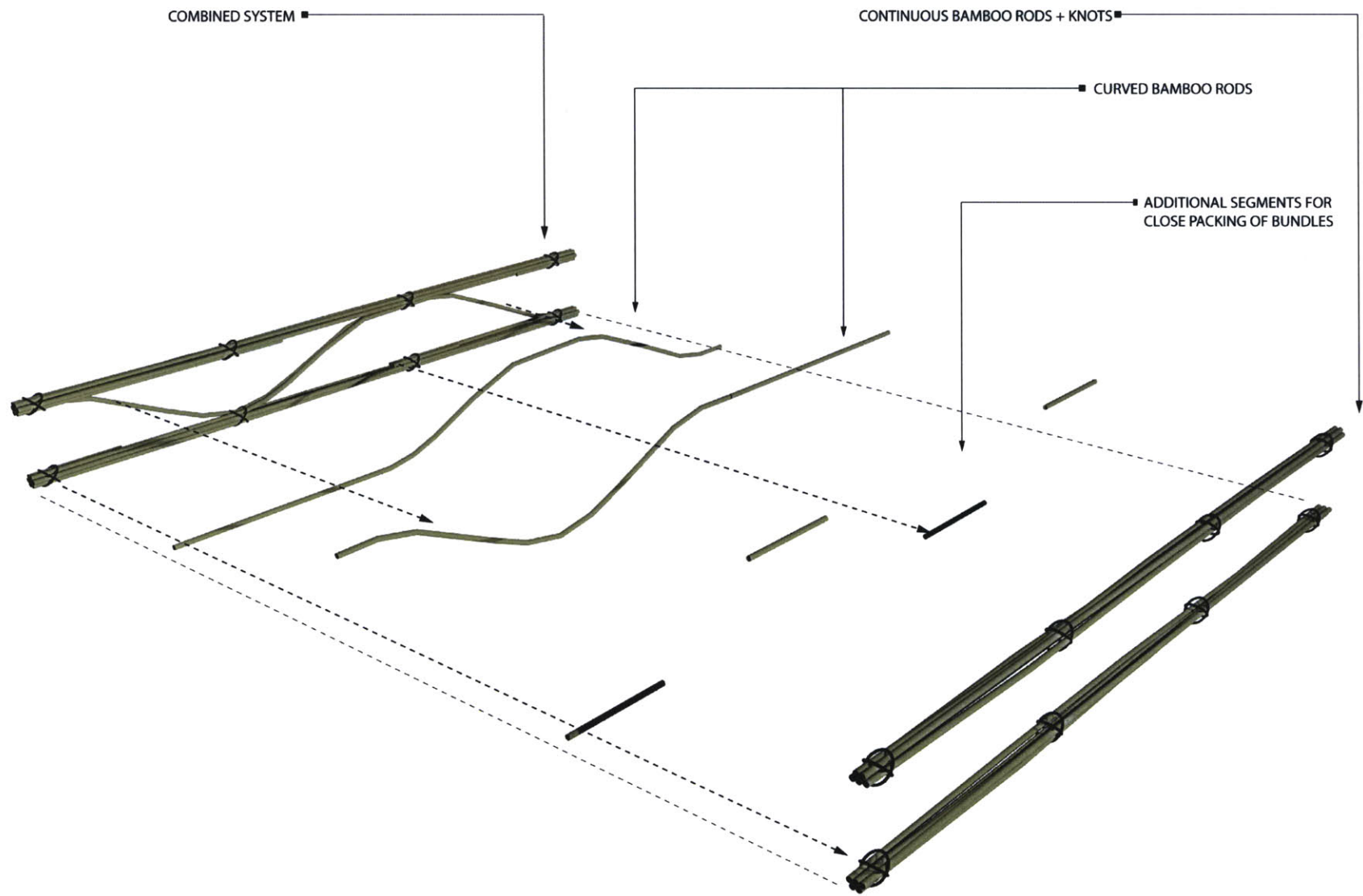

Assembly of rods and knots for the construction of a truss made of vegetal elements.

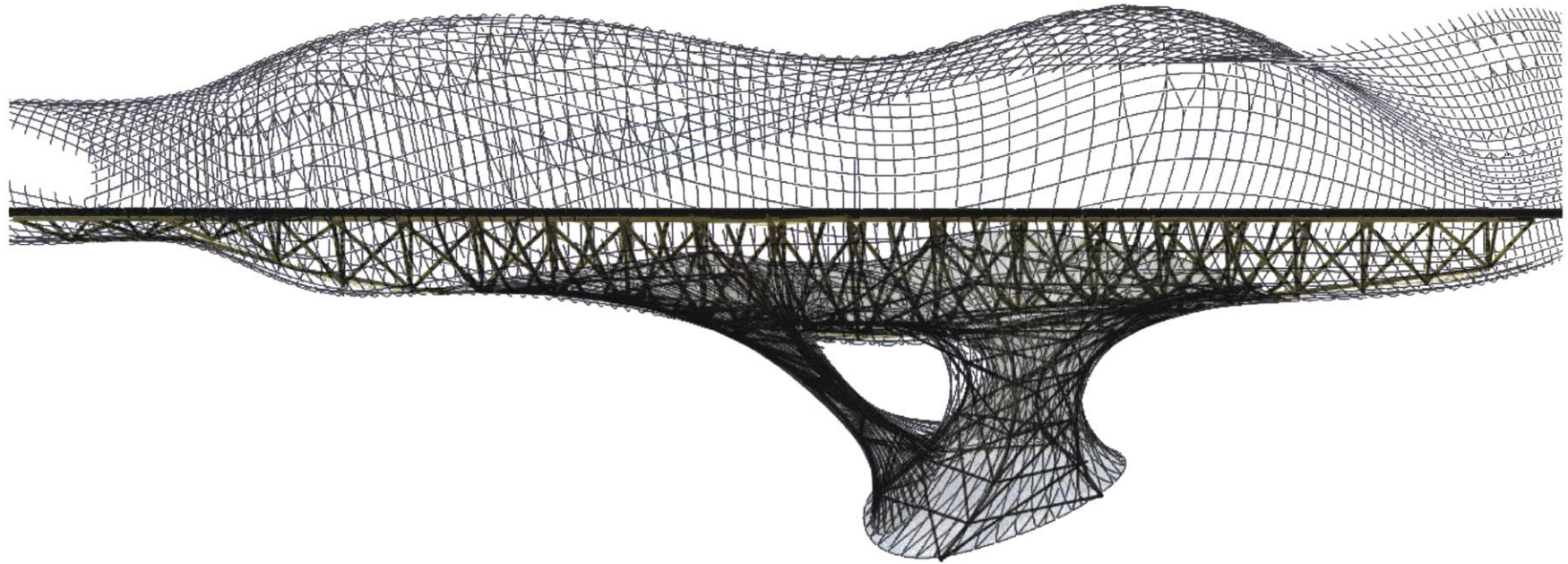

Information section of the building showing the structure of the deck: a triangulated truss of arched rods. The single core of structural support bifurcates to hold a larger area for weight distribution.

For larger structures such as the walking deck of the bridges, a system of arches made of bent rods are placed at intervals, while their lowest point and their ends are tied together, forming a three dimensional triangulated network. Straight elements running along the arches are then used for bracing, similar to a ship's structure. This serves as the base for the bamboo that runs along the length of the bridge to support the floor. The finished bridge works as stem branching out from the vertical supports. The outer layer of the vertical structure is used to support the bridge, while the interior core continues upwards to serve as support for the enclosing surface of the building.

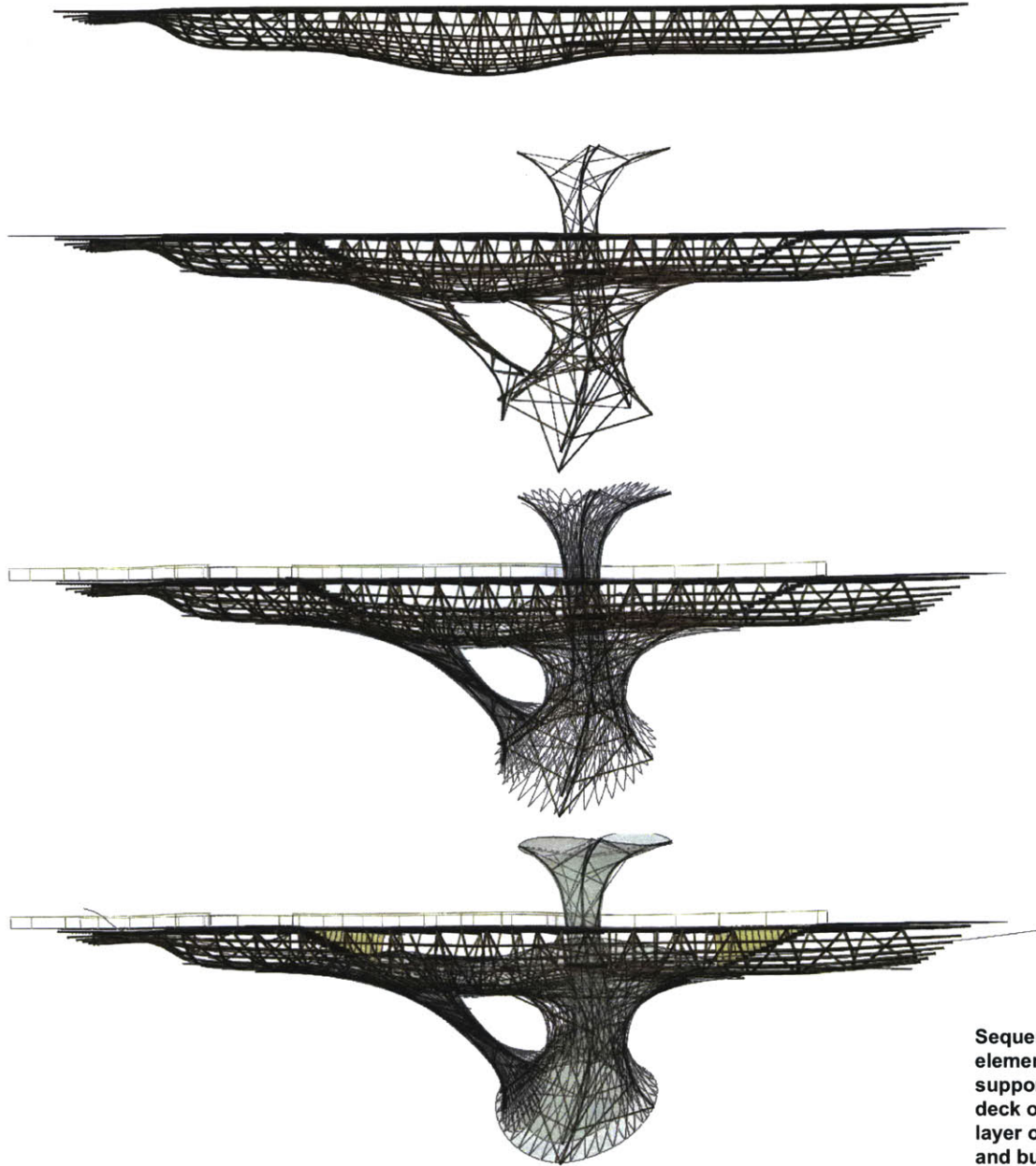

Sequence of images showing the different structural elements of a section of the building. The vertical support has a double core that supports both the deck of the bridge and the enclosure surface. Each layer of the structure has a different pattern of rods and bundles, for specific structural purposes.

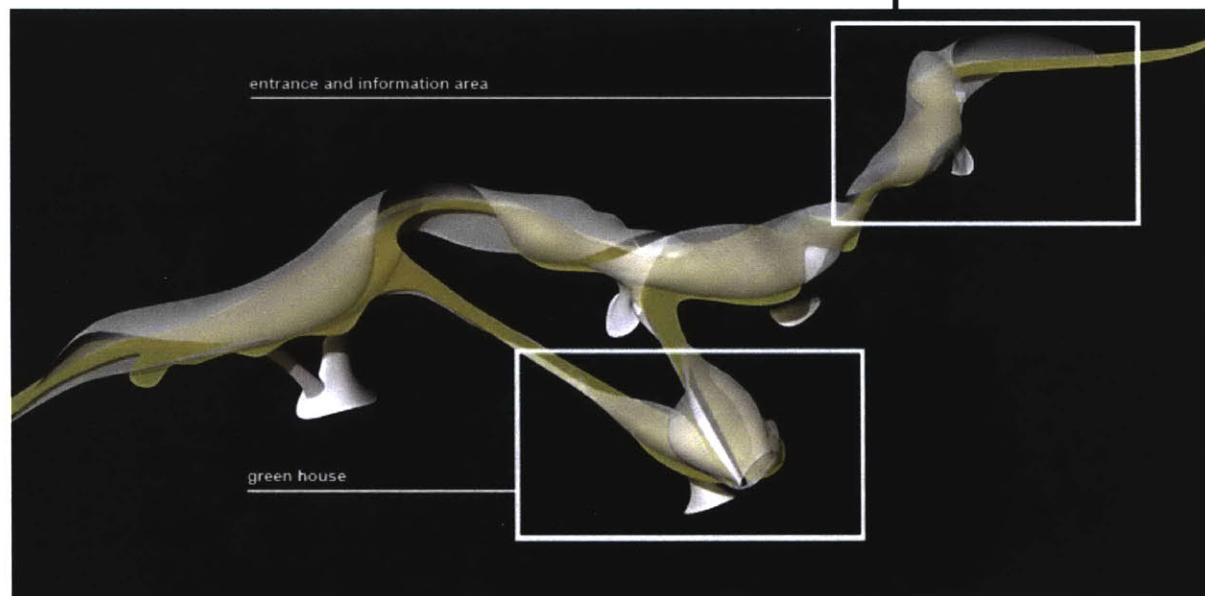
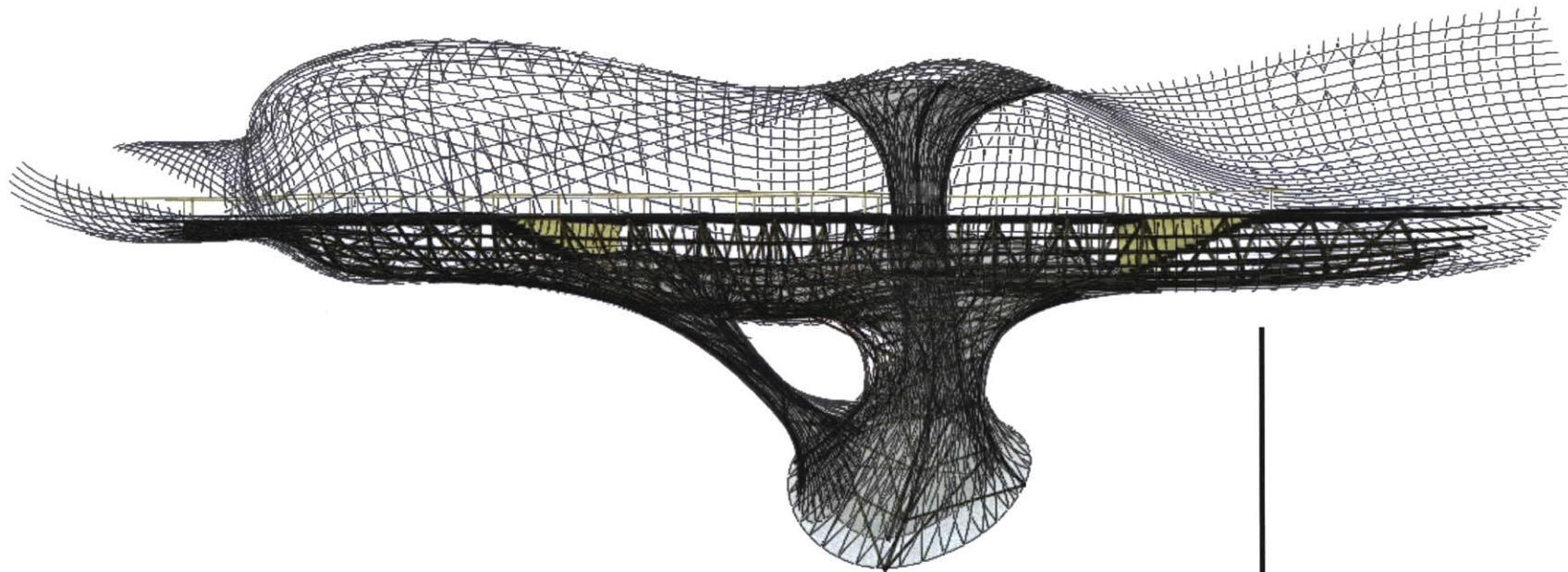

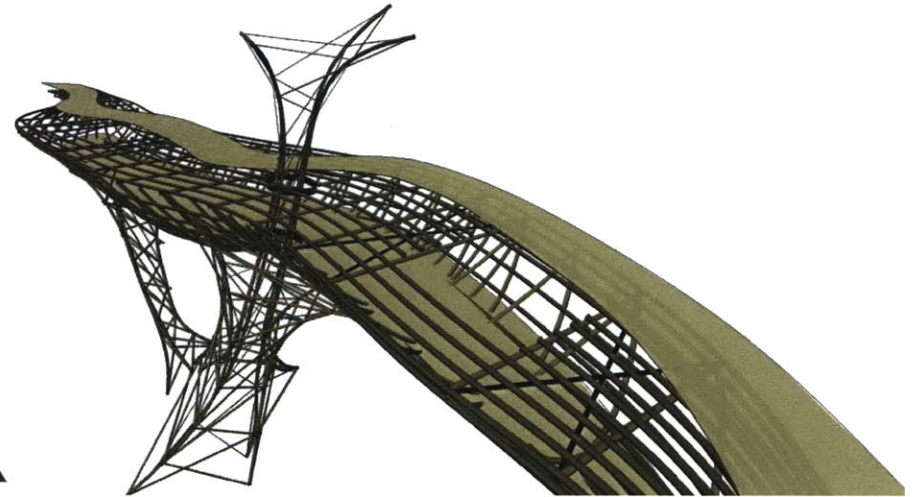
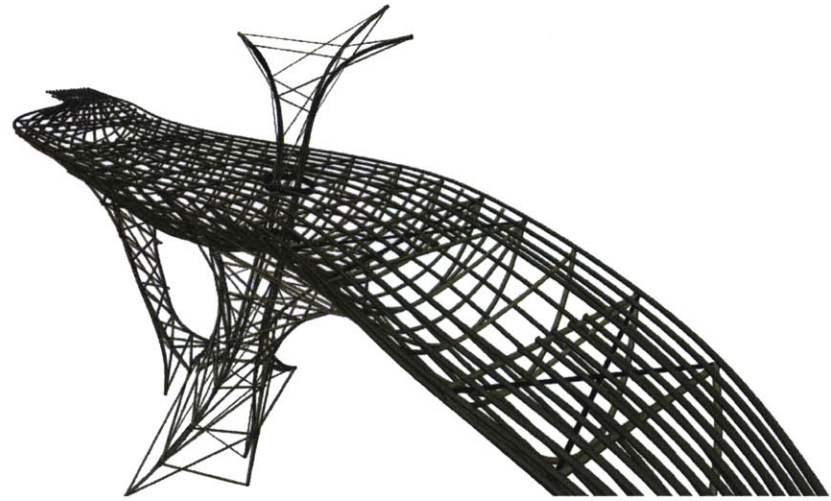
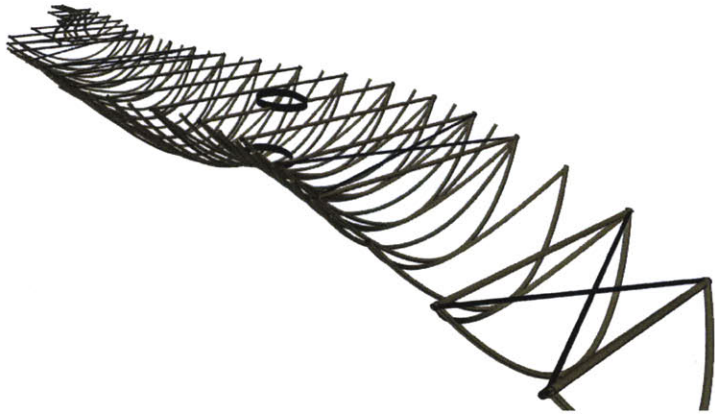

Different structural configurations form the building: A triangulated truss made of a series of variable arches is used for the interior structure of the deck in the bridge of the information area. A series of rods of different diameter run along the deck for support. The double-core vertical support is cross braced between curved bundles that support the bridge and the enclosure.

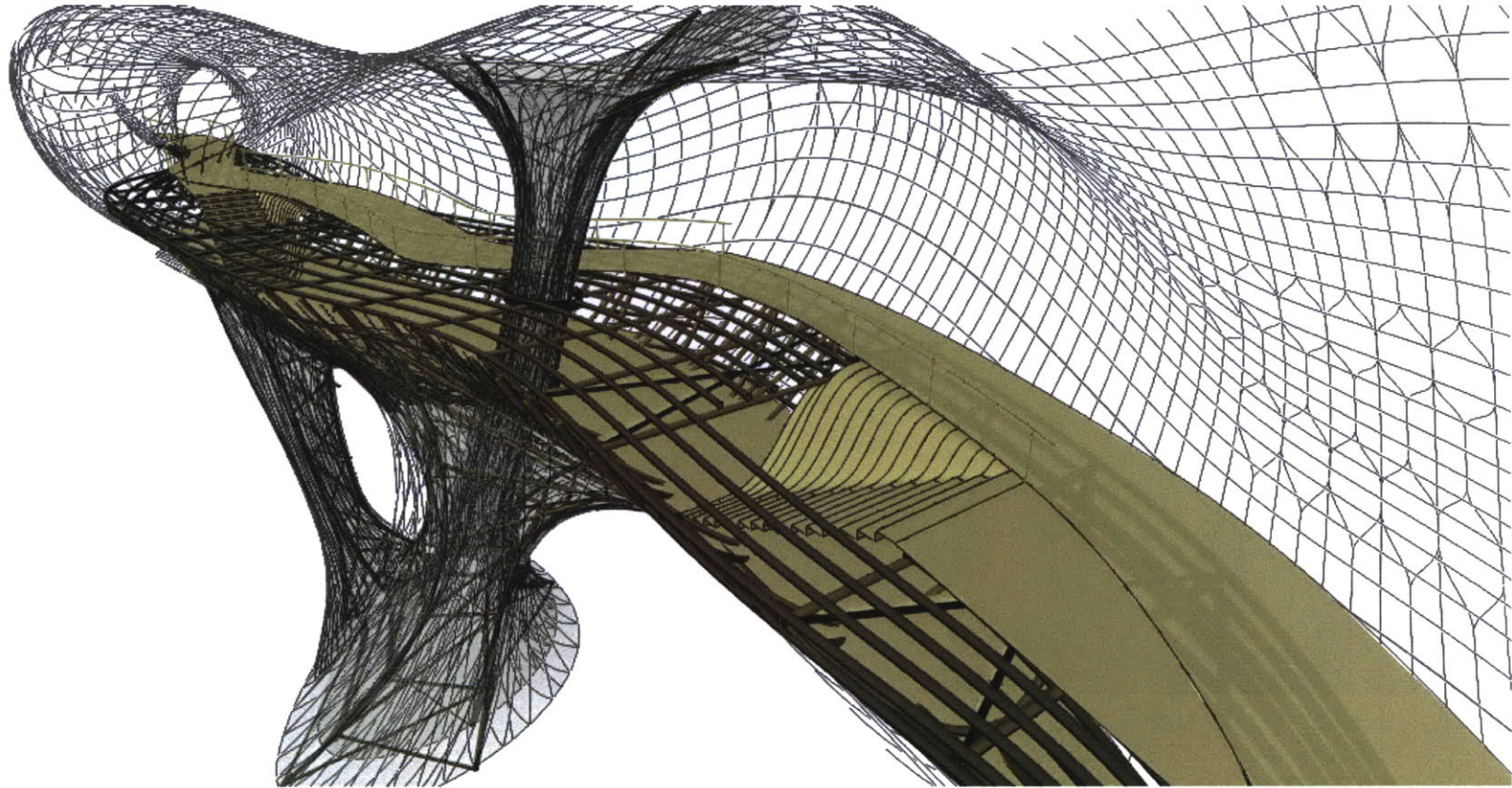

The image shows the two levels of the information area, and the different patterns for the enclosure in order to adjust to the required curvature.



For water tightness, the enclosure is composed of overlapping strips of industrial PVC foil for water drainage. The strips are fastened to the bamboo rods of the structure by a series of PVC clamps made of commercially available tubes cut in sections. Camo-net layers, usually used by the army and hunters, are laid on top of the foil and arranged for different levels of opacity and secured on the surface by stretched polyurethane cables with aluminum hinges at their ends and fastened on the rods.

Image 24: Left: Overlapping of a bird's feathers. Right: Enclosure assembly for water tightness of the enclosure.

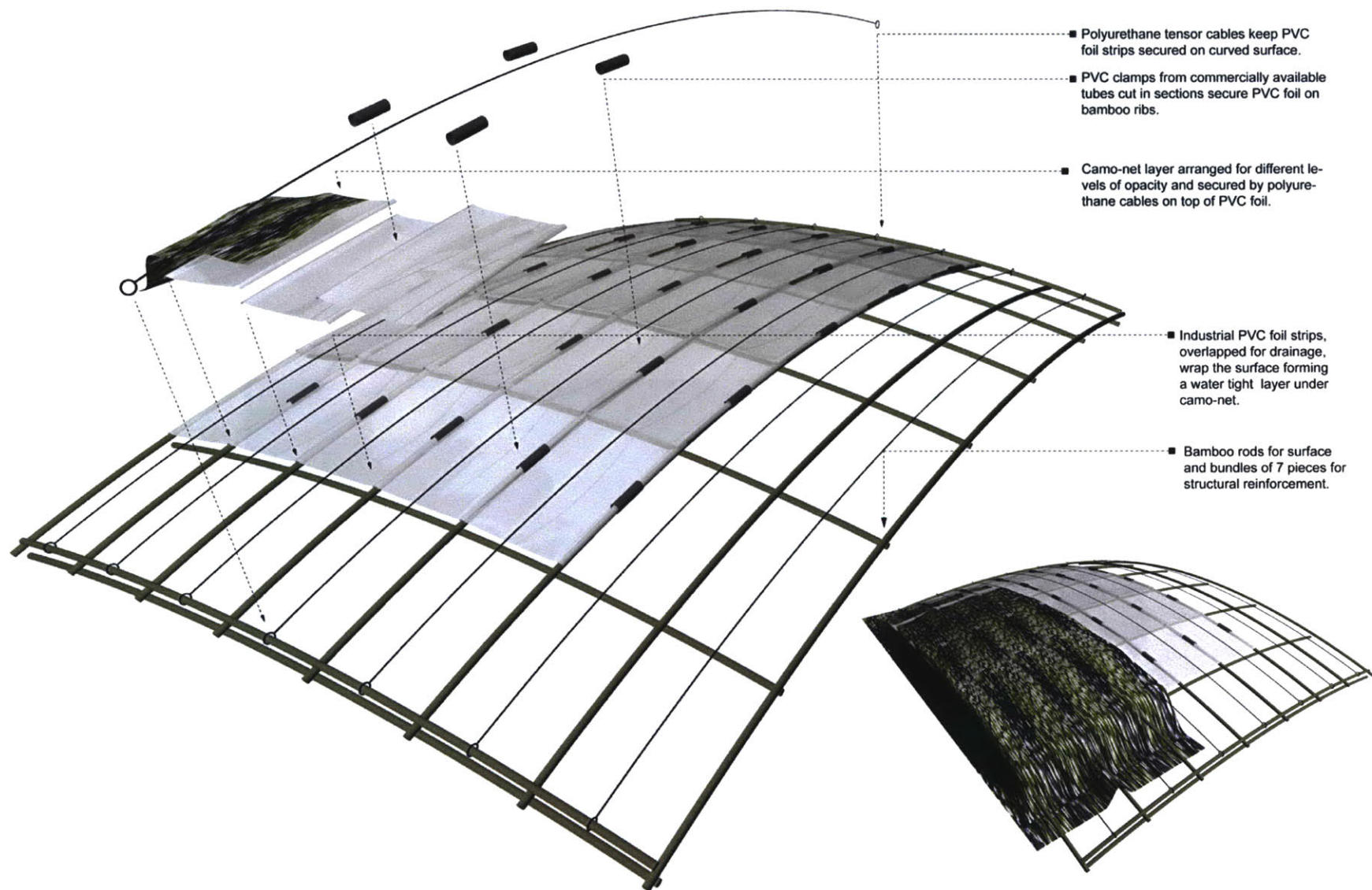

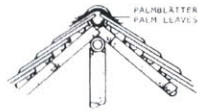
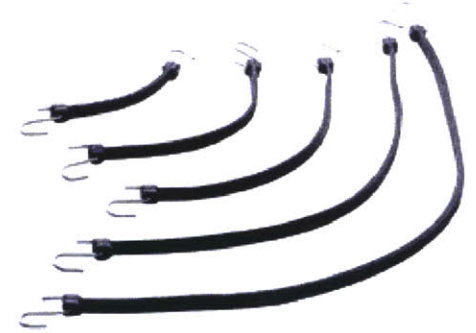
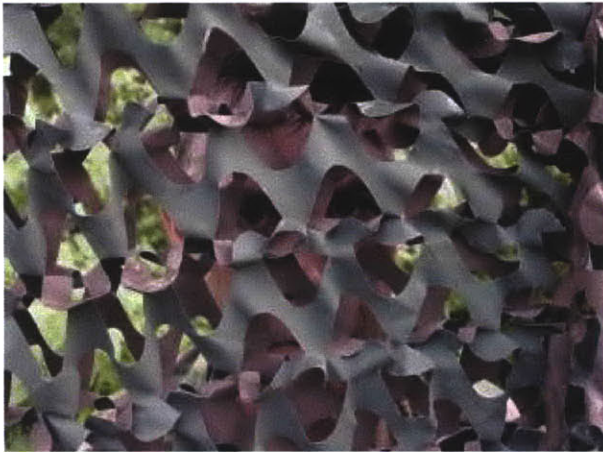

PALMBLÄTTER
PALM LEAVES

BAMBUS-
SPÄRREBLATT
VERTICAL
BAMBOO BATTEN

BAMBUS-
DACHREIßTEN ca. 5-15mm
ALS SPÄRREBÄLGEN
BAMBUS-RIPPE BÄTTENS
APP. 5-15mm USED AS
BOARDING

BAMBUS-
SPÄRREBLATT
VERTICAL BAMBOO
BATTEN

BAMBUS-
LÄTTEN ca. 45-10mm
BAMBUS-RIPPE
BÄTTENS APP. 15-30mm

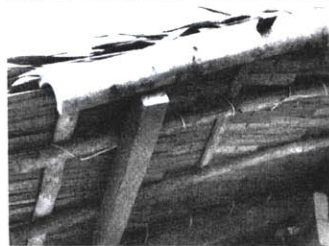
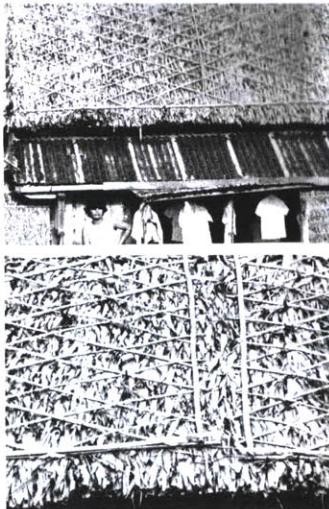

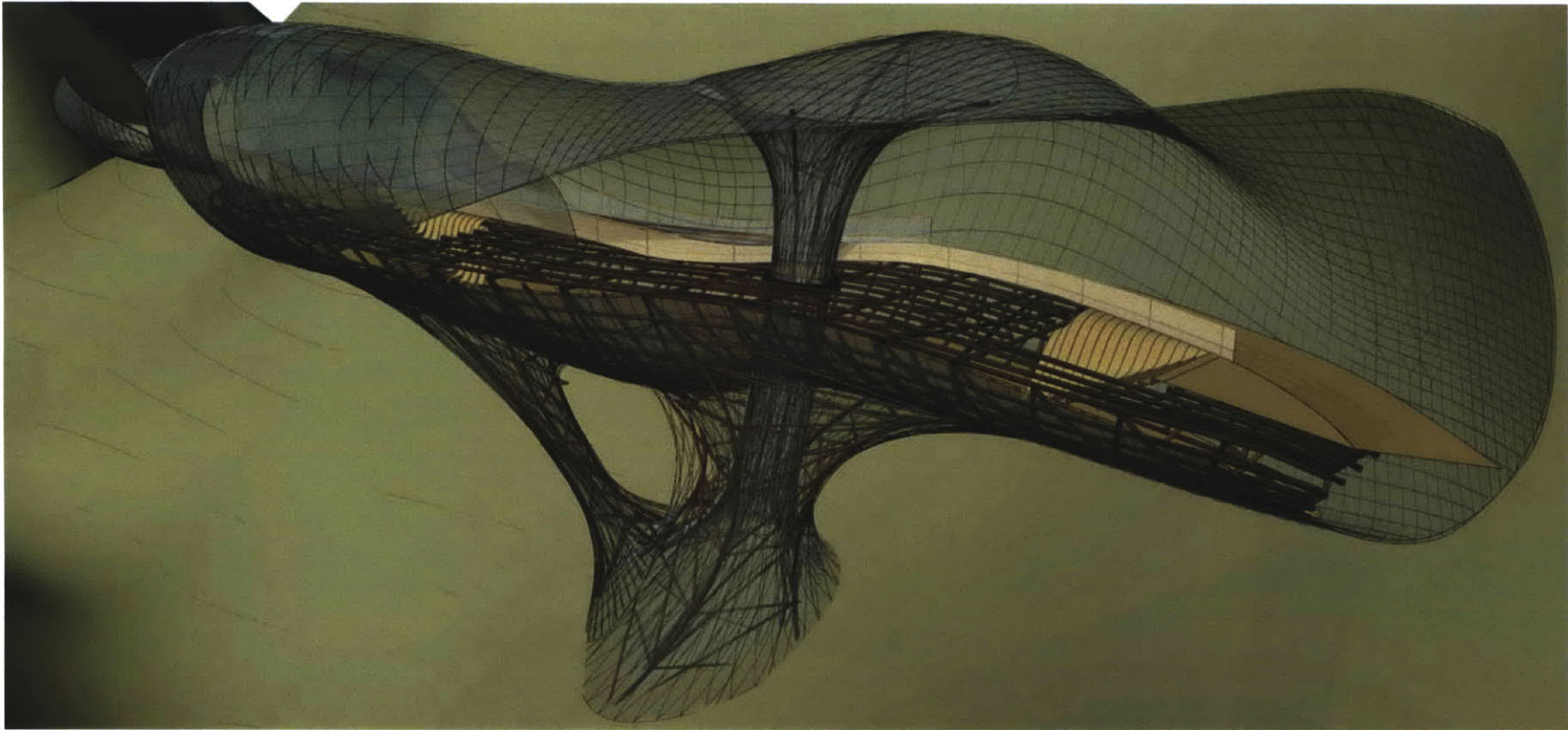
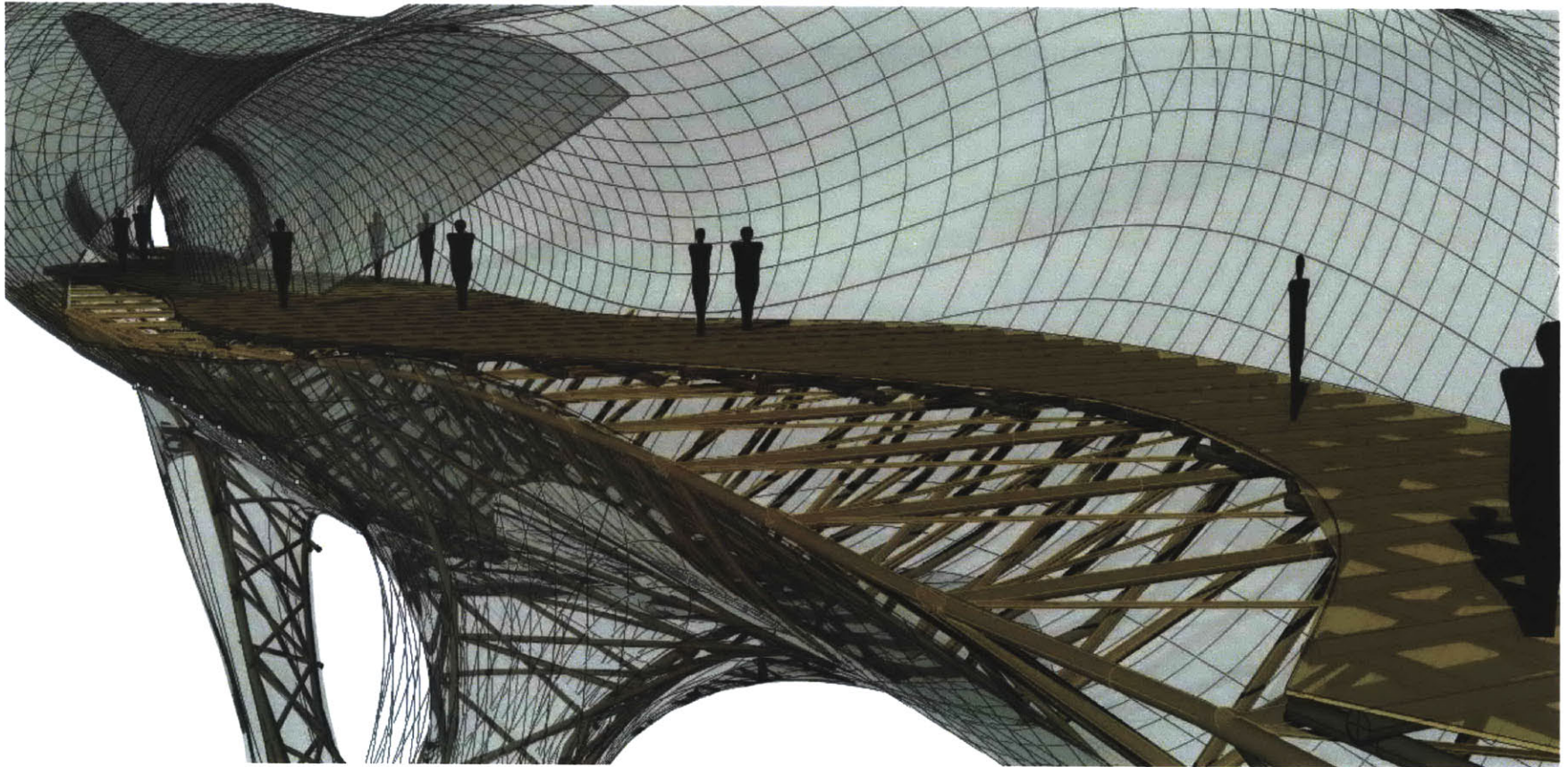
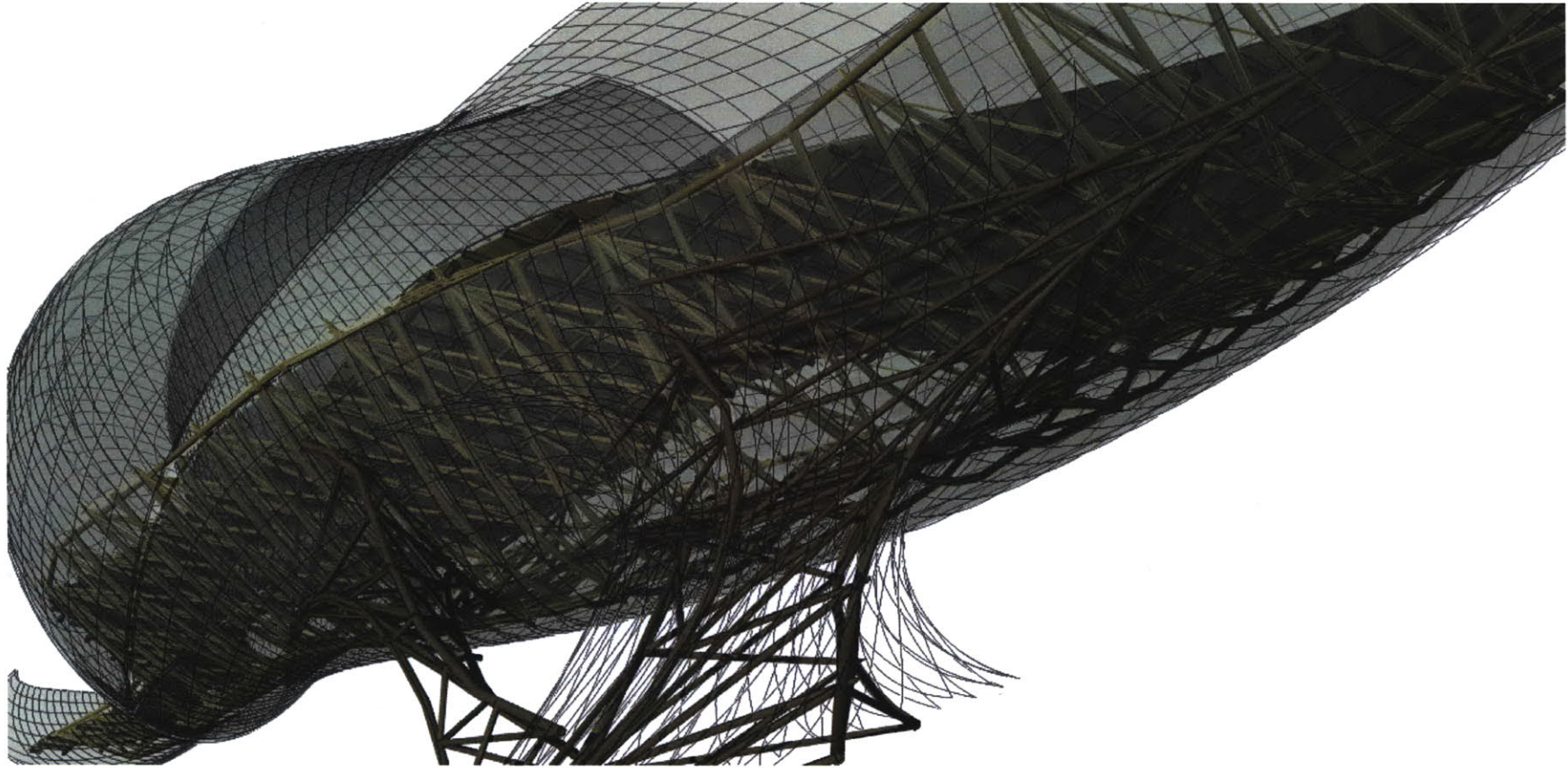
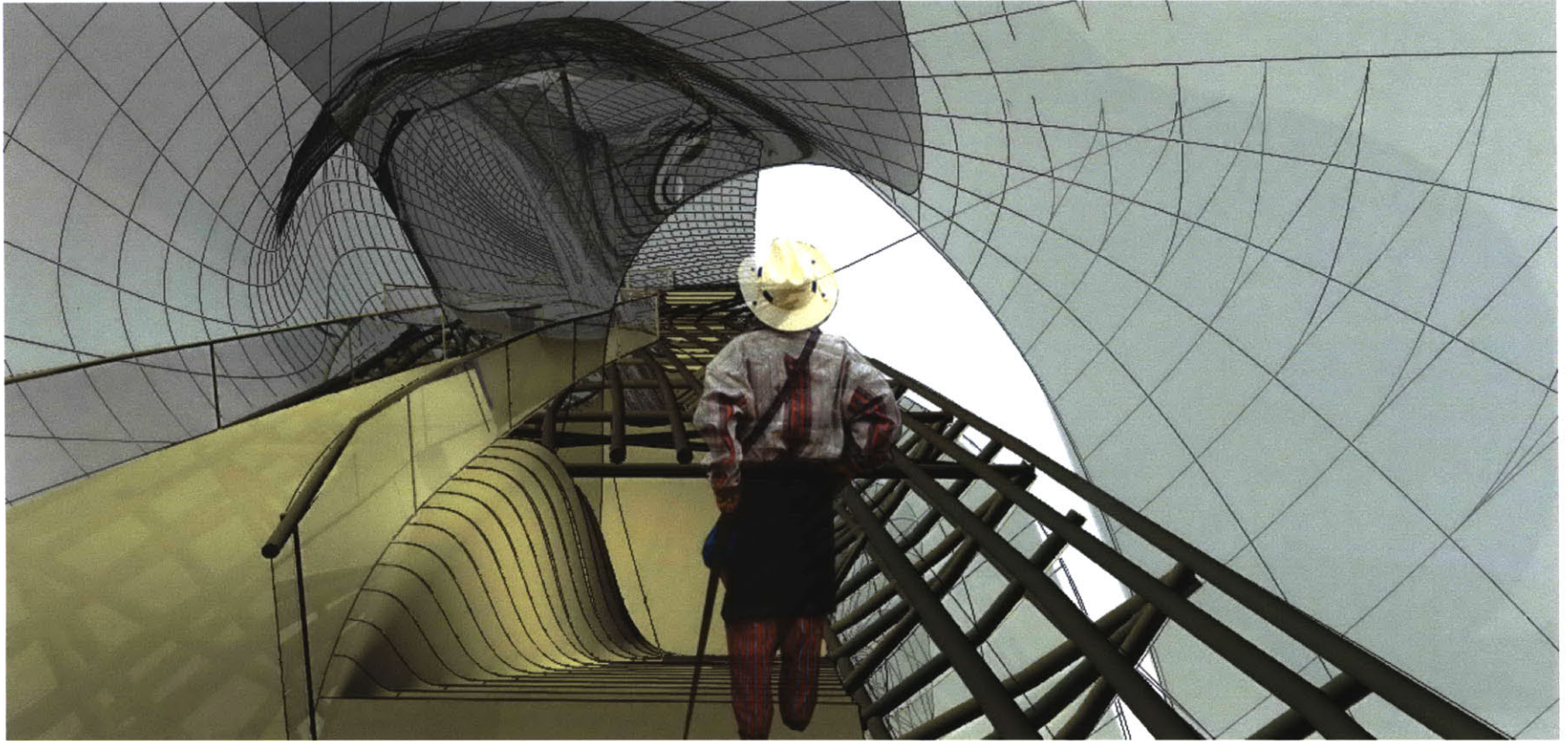
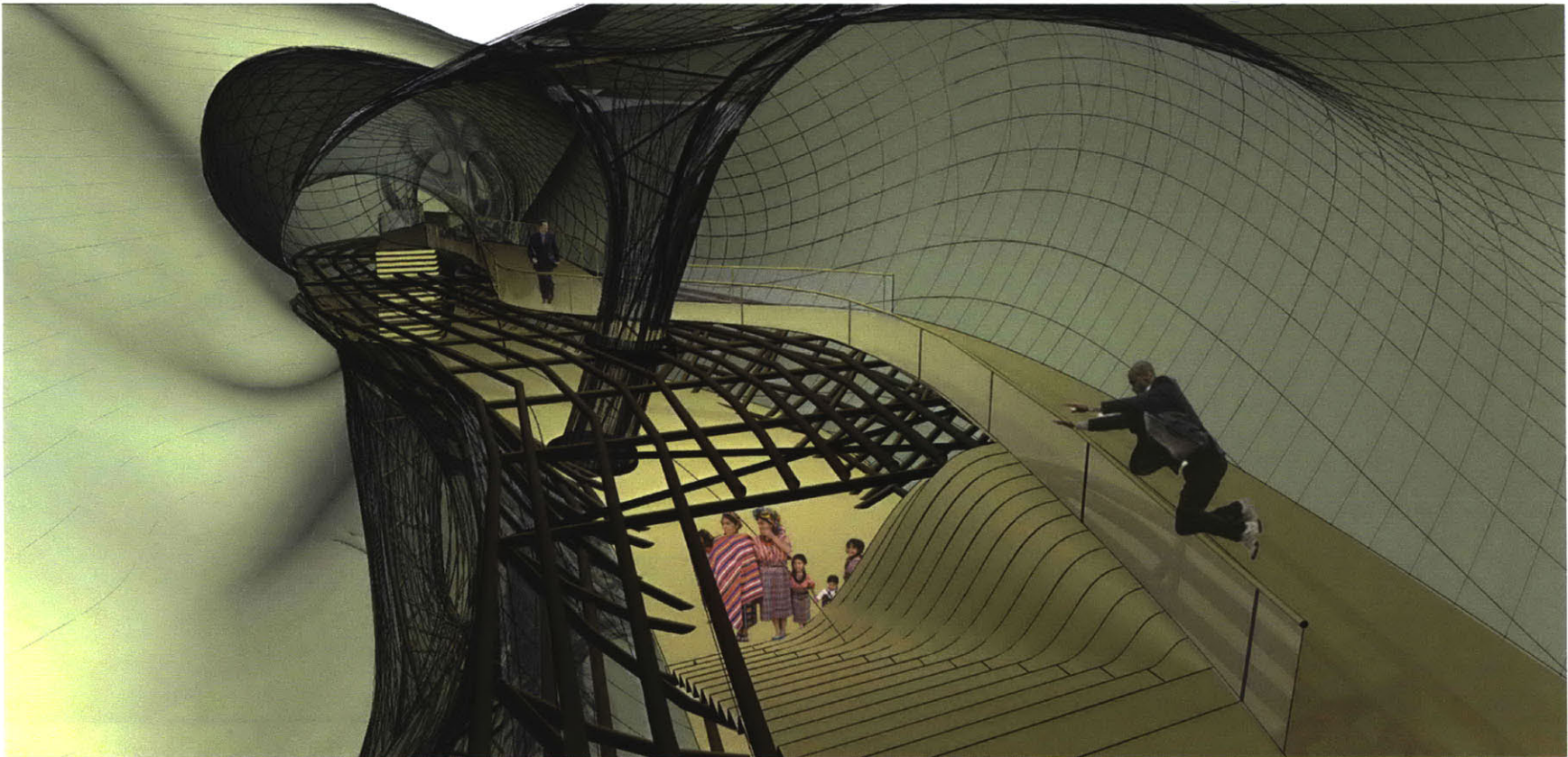

Image 25, 26-29. Clockwise: Thatching system as a possible solution for water tightness, and system of camo-net to be employed on the surface at different arrangement patterns for opacity variation. Right: image of information area of the building and its relation to the ravine.









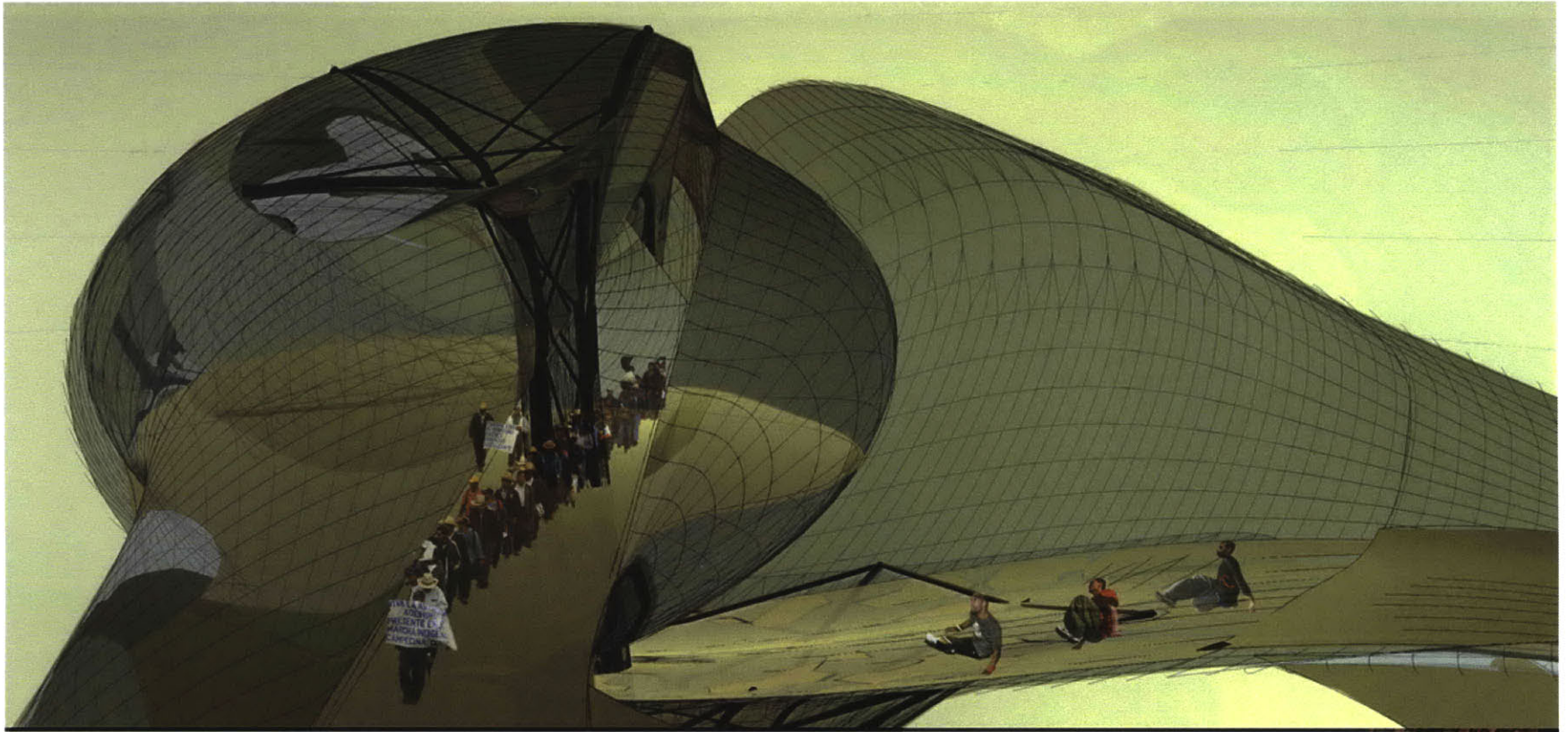

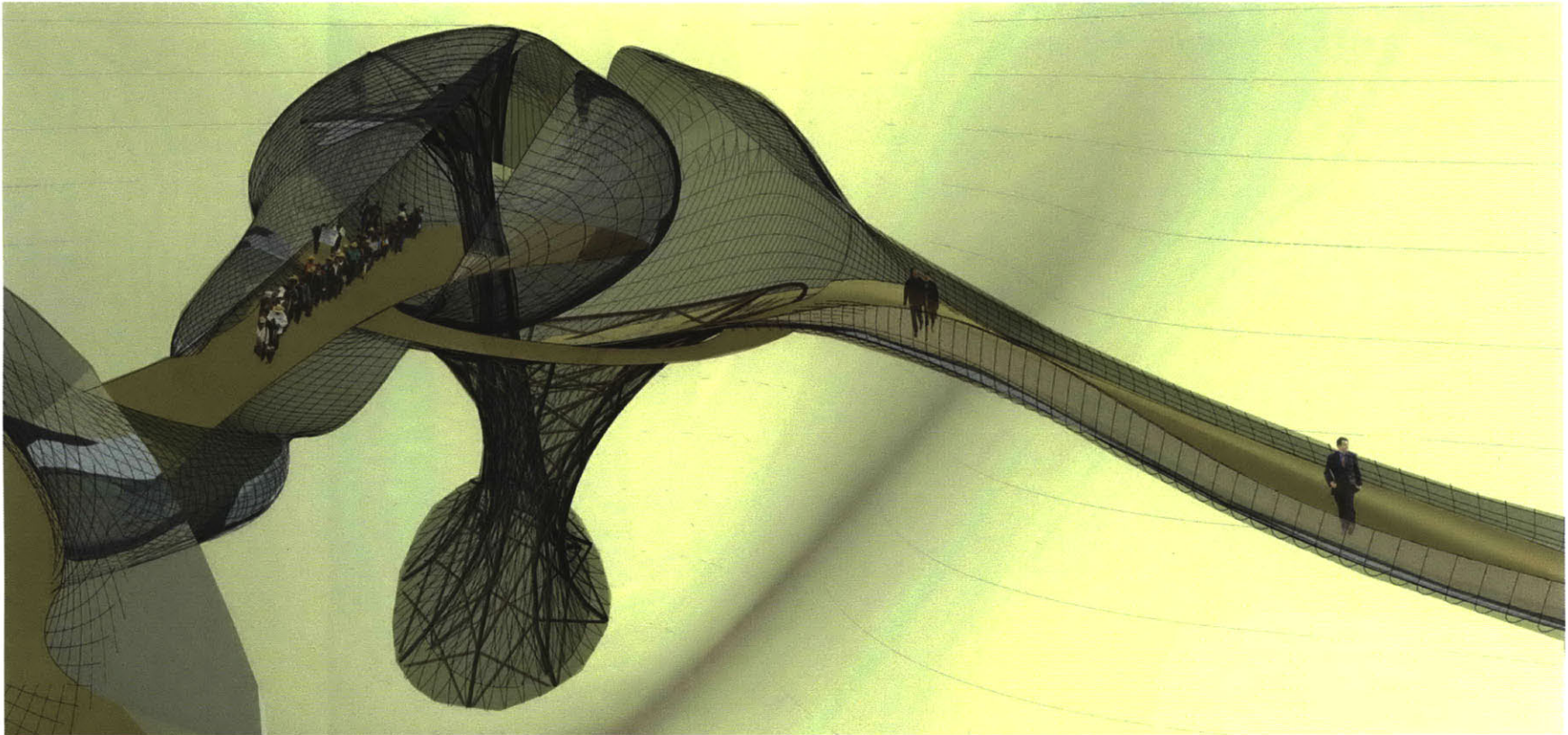

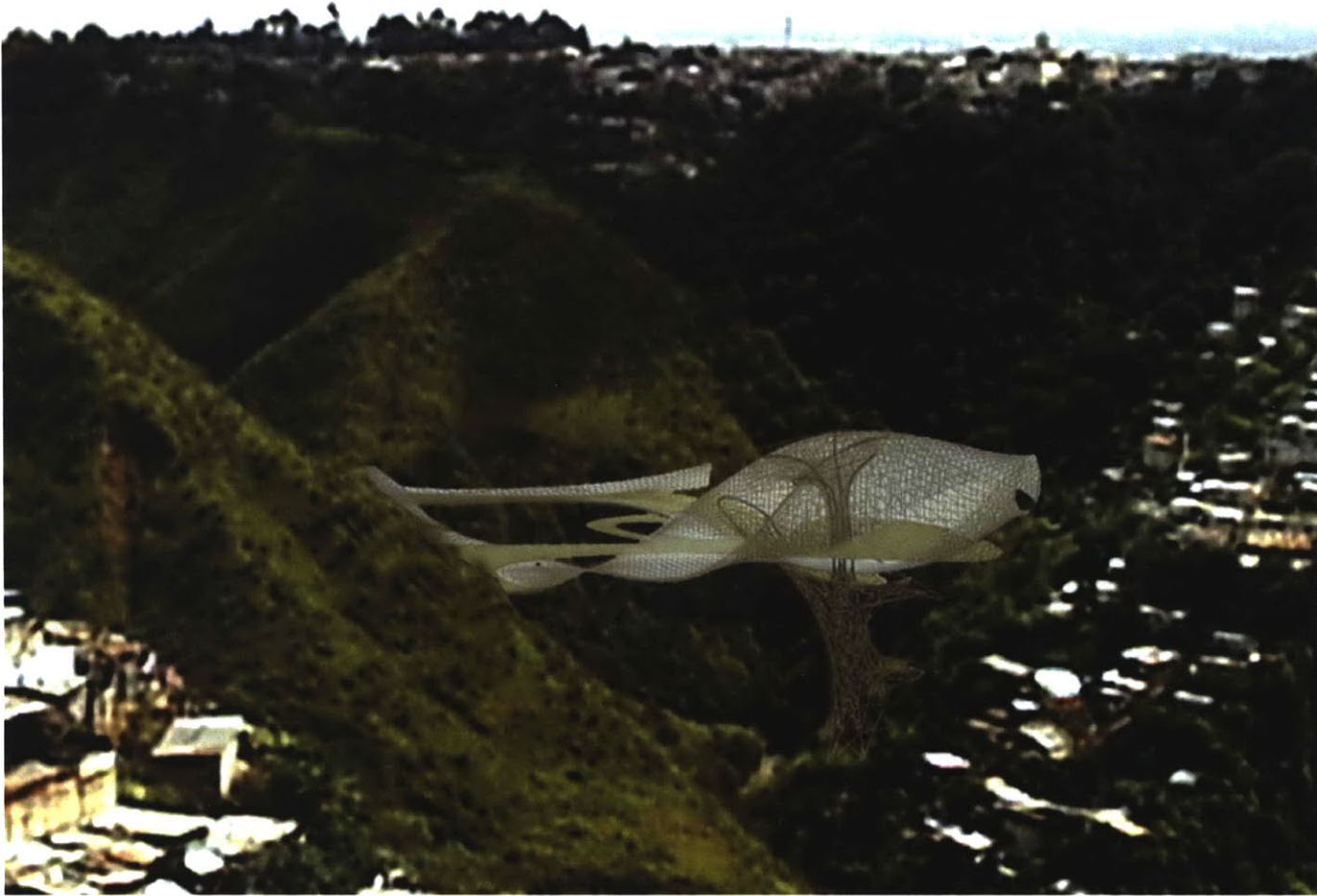



8. CONCLUSION

The design of the Ecological Visitor Center provides a solution for new public spaces and parks for Guatemala City, while it raises the awareness of these natural environments in the urban fabric of this sprawling city. Although new policies for the conservation of these natural ravines are being proposed, the solutions focus mainly on declaring them inaccessible areas for any kind of intervention and public access. New solutions for their sensitive use need to be proposed by re-thinking these corridors beyond the current notion of “obstacles” for urban development, or as future enclosed and out-of-bounds areas. Instead, these ravines have the potential to become natural urban lungs for public access and sensitive recreation. In this context, the design of the building for the Ecological Visitor Center shows how traditional methods of design and construction can be employed in conjunction with digital design techniques in order to develop a new kind of architecture for these ravines. The architecture proposed for this building is no longer concerned about the synthetic perfection of its design as a high-tech industrial object for the city. It proposes the use of local materials, natural or industrial, in ways that are different than the conventional practice, pushing these materials and local techniques into new directions. With new computational design tools and exploration, these traditional techniques and locally available materials have the potential to be part of a new design research. Construction challenges and complexities that can arise from innovations in architectural design can therefore be addressed with locally available techniques. These technologies and materials are not mutually exclusive, and can in fact contribute towards questioning their conventional exclusiveness to either high-tech discourses or low-tech vernacular conformism. Nature does not end with technology. Instead, their generative potential is enhanced by the constant feedback between analogue and digital tools, natural and synthetic materials, hand-craft and automated methods, and tradition and innovation in design.

SOURCES OF ILLUSTRATIONS

- 1-6,8,16-17,19, 22, 24 "Revelations, Latin American Wisdom for Every Day", by Danielle and Olivier Föllmi, Abrams, New York.
- 7 "Lightness, The Inevitable Renaissance of minimum energy structures", by Adriaan Beukers and Ed van Hinte, 010 Publishers, Rotterdam.
- 9-14, 25 "IL 31: Bambus - Bamboo", by Klaus Dunkelberg and the team of the IL, Karl Krämer Verlag, Stuttgart.
- 15 "IL 25: Experimente - Experiments", by Siegfried Graß, Karl Krämer Verlag, Stuttgart.
- 18-20, 21, 23 "On Growth and Form", by D'Arcy Thompson, Cambridge University Press, Cambridge
- 26-29 <http://www.camosystems.com>

WORKS CITED

Dunkelberg, Klaus. "Bambus als Baustoff – Bamboo as a Building Material." IL 25: Bambus - Bamboo. Ed. Siegfried Gaß. Stuttgart: Karl Krämer Verlag, 1985. 16-37.

Gaß, Siegfried. „Experiments in the Design Process.“ IL 31: Experimente – Experiments. Stuttgart: Karl Krämer Verlag, 1990. 7.00.

Hagan, Susannah. Taking Shape : A New Contract Between Architecture And Nature. Boston: Architectural Press, 2001. XVI.

Picon, Antoine. "Architecture, Science and Technology." The Architecture of Science. Eds. Peter Galison and Emily Thompson. London: The MIT Press, 1999. 309-336.

Bibliography

Architecture, Nature and Technology

- Cook, Jeffrey. Seeking Structure From Nature: The Organic Architecture of Hungary. Boston: Birkhäuser, 1996.
- Dollens, Dennis. Digital-Botanic Architecture St. Paul: SITES Books, 2005).
- Dollens, Dennis. Exodesic: Structures, Tumbleweeds, Electronics. Santa Fe: SITES Books, 1999.
- Dollens, Dennis. D2A: Digital To Analog. Santa Fe: SITES Books, 2001.
- Hagan, Susannah. Taking Shape : A New Contract Between Architecture And Nature. Boston: Architectural Press, 2001.
- Marras, Amerigo, ed. ECO-TEC: Architecture Of The In-Between. New York: Princeton Architectural Press, 1999.
- Slater, Candace, ed. In Search Of The Rain Forest. Durham: Duke University Press, 2003.

Art, Ecology and Technology:

- Beahan, Virginia and McPhee, Laura. No Ordinary Land : Encounters In A Changing Environment New York: Aperture, 1998.
- Marx, Leo. 1919- The Machine In The Garden;Technology And The Pastoral Ideal In America. London; New York: Oxford University Press, 1967.
- Scott, Felicity D. "Architecture or Techno-Utopia". Grey Room, Volume 1, Number 3. Cambridge: MIT Press, April 2001.
- Spaid, Sue. Ecovention: Current Art To Transform Ecologies. Cincinnati: Contemporary Arts Center, 2002.

Architecture and Science

- De Landa, Manuel. "Material Complexity." Digital Tectonics, ed. Neil Leach. London: Wiley, 2004.
- De Landa, Manuel. Intensive Science and Virtual Philosophy. London: Continuum, 2002.
- Galison, Peter and Thompson, Emily, eds. The Architecture of Science. Cambridge: The MIT Press, 1999.

Picon, Antoine and Ponte, Alessandra, eds. Architecture and The Sciences: Exchanging Metaphors. New York: Princeton Architectural Press, 2003.

Wolfram, Stephen. A New Kind of Science. Champaign: Wolfram Media, 2002.

Materials and Composites:

Addington, Michelle and Schodek, Daniel. Smart Materials and Technologies for the Architecture and Design Professions. Oxford: Architectural Press, 2005.

Ball, Phillip. The Self-made Tapestry. Oxford: Oxford University Press, 1999.

Beylerian, George. Material ConneXion: The Global Resource of New and Innovative Materials for Architects, Artists, and Designers. Hoboken: Wiley, 2005.

Benjamin, Jayne A. ed. Theory and Design of Wood and Fiber Composite Materials. New York: Syracuse University Press, 1972.

Drzal, Lawrence; Misra, Manjusri and Mohanty, Amar K., eds. Natural Fibers, Biopolymers and Biocomposites. Boca Raton: Taylor and Francis Group, 2003.

ESCAP, RILEM and CIB, Building Materilas for Low-income Housing. London: E. & F. N. Spon, 1987.

Fernandez, John. Material Architecture: Emergent Materials for Innovative Buildings and Ecological Construction. Amsterdam; Boston: Architectural Press, 2006.

Jacobs, James A. and Kilduff, Thomas F. Engineering Materials Technology. Upper Saddle River, 2005.

Martinez, Enrique and Steinberg, Marco eds. Material Legacies. Providence: The Department of Industrial Design Risde, 2000.

Sobral, H. S. ed. Vegetable Plants and their Fibers as Building Materials. Cambridge: University Press, 1990.

Spence, R. J. S. and Cook, D. J. Building Materials in Developing Countries. London: Wiley, 1983.

Stattmann, Nicola. Ultra Light – Super Strong. Basel: Birkhauser, 2003.

Van Onna, Edwin. Material World 2. Paris: Birkäuser, 2006.

Wallenberger, Frederick T. and Weston, Norman E., eds. Natural Fibers, Polymers and Composites. Boston: Kluwer Academic Publishers, 2004.