

**GROUNDWATER MODELING TO PREDICT PLUME MIGRATION  
AND TO DESIGN A WELL FENCE FOR A FUEL SPILL AT THE  
MASSACHUSETTS MILITARY RESERVATION**

by

**Vanessa Riva**

B.S.E. Civil Engineering  
Loyola Marymount University, 1995

Submitted to the Department of Civil and Environmental Engineering in Partial  
Fulfillment of the Requirements for the Degree of

**MASTER OF ENGINEERING IN CIVIL AND ENVIRONMENTAL ENGINEERING**

at the

**MASSACHUSETTS INSTITUTE OF TECHNOLOGY**

June, 1996

© 1996 Vanessa Riva  
All Rights Reserved

the author hereby grants MIT permission to reproduce and to distribute publicly paper  
and electronic copies of this thesis document in whole and in part.

Signature of Author \_\_\_\_\_

\_\_\_\_\_  
Vanessa Riva  
May 24, 1996

Certified by \_\_\_\_\_

\_\_\_\_\_  
Dennis McLaughlin  
Professor of Civil and Environmental Engineering  
Thesis Supervisor

Accepted by \_\_\_\_\_

MASSACHUSETTS  
OF TECHNOLOGY

\_\_\_\_\_  
Joseph M. Sussman  
Chairman, Departmental Committee on Graduate Studies

JUN 05 1996

Eng.

LIBRARIES

# **GROUNDWATER MODELING TO PREDICT PLUME MIGRATION AND TO DESIGN A WELL FENCE FOR A FUEL SPILL AT THE MASSACHUSETTS MILITARY RESERVATION**

by

**Vanessa Riva**  
B.S.E. in Civil Engineering  
Loyola Marymount University

Submitted to the Department of Civil and Environmental Engineering on May 24, 1996,  
in partial fulfillment of the requirements for the degree of  
Master of Engineering in Civil and Environmental Engineering

## **Abstract**

This thesis involves the development and utilization of a groundwater model to predict the movement of a fuel spill plume, and to design an extraction well fence for its containment. The modeled fuel spill is located on the Massachusetts Military Reservation where years of military presence have produced widespread contamination of the underlying aquifer. The aquifer is unconfined and characterized by highly conductive sandy soils and a very deep water table. The model was developed by utilizing a finite element groundwater computer program, DYN-System. The equilibrium natural flow field was first modeled and calibrated. The calibrated flow field was then used to perform particle tracking analysis to determine the movement of the plume. Various schemes for the design of the extraction well fence were analyzed and simulated using the modeled flow field under transient conditions. The well fence design was based on a capture curve analysis of simulations results. Several systems, each with a different number of wells, were simulated to determine the minimum required pumping rate for complete plume containment. These well systems all effectively captured the plume at a minimum pumping rate and thus provided a set of optimal extraction well fence designs. A cost analysis was conducted among the optimal well systems to determine the most economical design. Therefore the final design provide the most efficient extraction well fence design to effectively contain the plume at the lowest possible cost.

Thesis Supervisor: Dennis McLaughlin  
Title: Professor of Civil and Environmental Engineering

## ACKNOWLEDGMENTS

First of all I want to thank and acknowledge the person that I care for the very most, for being always there every second.

I would like to thank my Mamma for giving me the opportunity of being here, and for always “tifare” for me.

This thesis concludes my very exciting experience and work at MIT. It is the product of my study and of the support, encouragement and help that I have received from both faculty and students. Therefore, I would like to thank everyone that knows me. However, some have done a lot more for me and my thesis and as such they require special acknowledgments.

In particular, I want to thank Professor McLaughlin, my thesis supervisor, for being so resourceful and helpful through the thesis preparation and especially towards the end, when the pressure started to increase “exponentially”.

I want to thank Professor Marks, my advisor, for everything he has done for my experience through the M.Eng. program. It was excellent.

I would like to acknowledge the understanding, patience and continued support of Professor Gelhar. His teaching as well as his suggestion were always on target and very highly considered.

In addition, but not least I would like to thank Bruce Jacobs for teaching me all the “tricks and secrets” of DYN-System and listening to all the questions I had.

And of course I would like to thank everybody that has helped me in any way.

# TABLE OF CONTENTS

<b>1. INTRODUCTION</b>	<b>5</b>
1.1 BACKGROUND	5
1.2 ANALYSIS DESCRIPTION	6
<b>2. GROUNDWATER COMPUTER MODELING</b>	<b>7</b>
2.1 BASIC CONCEPTS OF NUMERICAL MODELS FOR GROUNDWATER FLOW	7
2.2 THE DYN - SYSTEMS	10
<b>3. FUEL SPILL 12 MODEL OF NATURAL GROUNDWATER FLOW</b>	<b>12</b>
3.1 CONCEPTUAL MODEL	12
3.2 DISCRETIZATION	14
3.3 BOUNDARY CONDITIONS	15
3.4 SOIL LAYERS AND MATERIAL	16
<b>4. PLUME MIGRATION MODEL</b>	<b>21</b>
4.1 PARTICLE TRACKING	21
4.2 DATA INPUTS	22
<b>5. WELL EXTRACTION FENCE DESIGN</b>	<b>24</b>
5.1 AQUIFER TEST DUPLICATION	24
5.2 LOCATION AND EXTENT OF PLUME TO BE CONTAINED	25
5.3 WELL FENCE PLACEMENT AND LAYOUT	25
5.4 DESIGN METHOD: CAPTURE CURVES	28
<b>6. COMPUTER MODELING RESULTS</b>	<b>30</b>
6.1 NATURAL FLOW	30
6.2 CONTAMINANT MIGRATION	32
6.3 WELL EXTRACTION FENCE CONTAINMENT SYSTEM	33
<b>7. CONCLUSION</b>	<b>37</b>
7.1 ASSESSMENT OF MODELING RESULTS	37
7.2 RECOMMENDATIONS	38
<b>8. FIGURES</b>	<b>39</b>
<b>9. REFERENCES</b>	<b>65</b>
<b>10. APPENDIX</b>	<b>67</b>



# 1. INTRODUCTION

The Massachusetts Military Reservation (MRR) is a Superfund site located in Cape Cod. Many years of military presence have left extensive contamination in the aquifer underlying the reservation. The contamination consists of several spills of various types of contaminants. One of the spill, Fuel Spill 12 (FS-12), has introduced jet fuel JP-4 into the groundwater. FS-12 is located almost on top of the water table mound. Because groundwater flow velocities are not as high on the mound, FS-12 has not migrated as far as the other spills located on the MMR. However, clean up of the spill is considered of major importance because of the vicinity of a recreational pond, Snake Pond, and the dangerous nature of the contaminants present -- ethylene dibromide (EDB), and benzene, ethylene, toluene, and xylene known as BTEX. A study for the remediation of the groundwater and analysis of the water surface effects were conducted as part of a group project effort. The project also included an investigation of the public perception of the contamination and remediation, and a cost benefit analysis of alternative water resources. This thesis involves a detailed study, with description of methodology and results, for some of the issues covered by the group project. Specifically this thesis consists of: the modeling of the FS-12 flow field, the prediction of the plume migration, and the design of an extraction well fence for the containment of the plume.

## **1.1 Background**

The aquifer underlying FS-12 is part of the Western Cape Cod aquifer. This is an unconfined aquifer characterized by highly conductive sandy soils and high horizontal hydraulic gradients.

Consequently, the water table is located several feet below the ground surface, between 60 and 100 feet approximately. FS-12 is located close to the point of divide of the Western cape Cod aquifer. Therefore the local hydraulic gradient is much lower when compared to that of the regional aquifer. The geology of the local FS-12 area is much more heterogeneous than in other parts of the Western Cape Cod aquifer. The local soils contain various clay and silty soil lenses. Additional details on the geology and hydraulic properties are provided in the group project located in the Appendix.

## ***1.2 Analysis Description***

A finite element computer model was developed to represent flow under both equilibrium and transient conditions for the local flow field of FS-12. The plume's migration was predicted by performing particle tracking for the natural flow field developed by the model. The model of the local groundwater system for FS-12 was also employed in the development and design of the extraction well fence. The model particle tracking capabilities and simulation of transient flow were further utilized to determine and analyze the capture curves of the extraction well fence. The extraction fence was thus designed by capture curve optimization. Various extraction fence designs were simulated and analyzed to obtain the most efficient system with minimum pumping rate. Furthermore, to improve the extraction fence design an analysis of construction and operational costs was also conducted.

## 2. GROUNDWATER COMPUTER MODELING

The groundwater computer model for FS-12 was created and utilized for the analysis of flow and for the design of the extraction well fence. The model for natural flow was first built and analyzed to determine the equilibrium flow field. The results of the natural flow model were then applied for the simulation and analysis of transient flow with pumping. The transient flow model was utilized in the simulation and evaluation of different systems for the design of the extraction well fence. The program used was DYN-System which is based on the finite element method. This program has the capabilities of simulating a large variety of flow field conditions in addition to particle tracking.

### 2.1 Basic Concepts of Numerical Models for Groundwater Flow

Three dimensional groundwater flow can be described by the governing equation:

$$S_s \frac{dH}{dt} = \frac{d}{dx_i} \left( K_{ij} \frac{dH}{dx_j} \right)$$

where  $H$  is the piezometric head, in units of length (L);  $i$  and  $j$  represent the three dimensional coordinate system 1, 2, 3;  $K_{ij}$  is the hydraulic conductivity, depicting the flow per unit area, in the three dimensional coordinated system, in units of length per unit time (L/T);  $t$  is time, in units of time (T); and  $S_s$  is the specific storativity, or the volume of water released (or stored) per unit volume of aquifer per unit change in head, with units one over unit length (1/L). The governing flow equation is derived from Darcy's law:

$$q_i = -K_{ij} \frac{dH}{dx_j}$$

and from the continuity equation of flow:

$$\frac{dq_i}{dx_i} = -S_s \frac{dH}{dt}$$

An exact analytical solution to the governing equation for groundwater flow can only be found for simple idealized cases. The need for results for real world complex groundwater flow systems has led to the use of numerical methods to solve the equations describing groundwater flow. The most widely used methods are the finite difference and the Galerkin finite element method. The finite element method is more accurate than the finite difference because it can approximate irregularities in the boundary geometry by the use of flexible elements' shapes. This method makes use of elements, or sub-regions, in which the area under study is subdivided. The geometry of these elements is very simple (prisms, tetrahedral, prisms, etc.) and they are defined by a particular number of nodes. The piezometric head is assumed to vary in a specified manner (linear variation, or quadratic variation). Based on the defined elements and head variation, local linear equations can be written describing the nodal flux in terms of the change in head for the each node of an element. Subsequently the local equations for each element can form a system of equations for the area under study. The system of equations can then be solved for the head or the flux at each of the nodes. For a single element the basic equations describing flow in each node are:

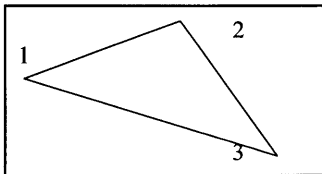

$$Q_1 = S_{11} * H_1 + S_{12} * H_2 + S_{13} * H_3$$

$$Q_2 = S_{21} * H_1 + S_{22} * H_2 + S_{23} * H_3$$

$$Q_3 = S_{31} * H_1 + S_{32} * H_2 + S_{33} * H_3$$

where  $Q_i$  represents the flow at node  $i$ ;  $H_j$  is the head value at node  $j$ ; and  $S_{ij}$  is the coefficient matrix relating the flux at node  $i$  to the head at node  $j$ . Thus, for each element a number of equations equal to the number of nodes defining the element can be written. Because of mass conservation, for the case of no flux, or zero flux, “the sum of the coefficient matrix rows ( $S_{11} + S_{12} + S_{13}$  etc.)” (Camp, Dresser & McKee, Inc., 1984) will be equal to zero. This defines the coefficient matrix. However, to determine a unique solution at least one value of head must be specified in the equations describing the nodes fluxes in each element. Therefore, the resulting equations will be as follows:

$$Q_1 = S_{11} * H_1 + S_{12} * H_2 + S_{13} * H_3$$

$$Q_2 = S_{21} * H_1 + S_{22} * H_2 + S_{23} * H_3$$

$$H_3 = - (S_{31}/S_{33}) * H_1 - (S_{32}/S_{33}) * H_2 + Q_3/S_{33}$$

where all values on the left hand side are known. Because of the third row arrangement the matrix columns will not sum to zero. Therefore a unique solution can be obtained by specifying the one value of head and the magnitude of flux for the remaining nodes. This type of solution is valid for either equilibrium or transient conditions with explicit storage fluxes. When implicit or trapezoidal storage fluxes are used in a transient situation the head values of the previous time step will be used as specified initial boundaries. Finite element method approaches non-linear solutions by a series of linear solutions, in which the previously computed values are used in the subsequent iterations. Iterations are continuously calculated until a pre-set convergence tolerance is reached.

The governing equation for the transport of a conservative pollutant is:

$$\theta \frac{dC}{dt} = \frac{d}{dx_i} \left( \theta D_{ij} \frac{dC}{dx_j} \right) - q_i \frac{dC}{dx_i}$$

where  $C$  is the concentration of the contaminant at any point, with units of mass per unit volume ( $M/L^3$ );  $q$  is the effective porosity, as a fraction;  $q_i$  the specific discharge, in length per time ( $L/T$ ); and  $D_{ij}$  is the dispersion coefficient, with units of length square per unit time ( $L^2/T$ ). Methods such as finite difference and finite element have been used to solve the governing equation for transport in groundwater. However, these methods do not provide exact answers as they are affected by numerical dispersion and “overshoot” (negative concentration). These errors arise from the fact that finite difference and finite element approach the solution of finite grid spacing and time step using the limiting case of indefinitely small time and space. Another approach used is the random walk analysis which demonstrate convergence to a normal distribution for a large number of particles in the limiting case of indefinitely small space. Logically it produces errors for the case of a finite number of particles and finite spacing. To eliminate errors associated with the limiting cases of indefinitely small time, and space and large number of particles, the Lagrangian method can be used. This uses random walk analysis for a select group of statistically significant particles. It then uses the flow velocity to convect the selected particles, and randomly disperses them by the given dispersion.

## ***2.2 The DYN - Systems***

The DYN - System is a collection of numerical solvers for the modeling of groundwater flow under natural conditions or under pumping (DYNFLOW), and particle tracking for the movement of contaminants (DYNTRACK). In addition, it is provided with a graphical interface (DYNPLOT) to analyze and present the results obtained from the flow model and particle tracking. DYNFLOW was developed by Camp Dresser & McKee in early 1982. DYNFLOW is written in FORTRAN and applies Galerkin finite element analysis to solve the governing equation of

groundwater flow. It uses three dimensional tetrahedral elements to simulate either equilibrium, natural flow, or transient, with pumping, conditions. DYNFLOW provides solutions through the use of finite elements, and can solve aquifer equations for both linear, confined aquifers, and non-linear, unconfined aquifers. It provides results by calculating head values and velocity vectors for each element in a time step process. It can account for anisotropy conditions in hydraulic conductivity. Through "rising water" nodes, the program allows drainage to streams in case the piezometric head is above the stream or lake bed. It also allows definition of multi-level pumping through the application of one-dimensional elements.

DYN - System also contains a particle tracking model, DYNTRACK, based on Lagrangian analysis. DYNTRACK can simulate, in the saturated zone, the movement of a simple single particle. This is used to determine the path, location and travel time of the contaminant. In addition, it can simulate three dimensional tracking for conservative, first-order decay contaminant, or for contaminants affected by adsorption and dispersion. The last simulation requires the use of random walk analysis, in which significant particles are defined by a mass weight, and decay and retardation rates are specified. The concentration is determined by dividing the total particle weight by the total volume occupied by the particles.

### **3. FUEL SPILL 12 MODEL OF NATURAL GROUNDWATER FLOW**

Following is the description of the assumptions and methods used in the building of the numerical model for FS-12. The groundwater flow was developed under natural conditions in which no pumping or other applied outflows are present.

#### ***3.1 Conceptual Model***

To properly develop the computer model for FS-12, a conceptual model of the area surrounding the contamination was conceived. Available documentation on the geology, stratigraphy and hydrogeology (USGS., 1974; LeBlanc et al., 1986; Savoie, 1993) was studied to determine the appropriate location and extent of the grid that defines the area to be included in the model. The region that the model covered was much larger than the actual zone of interest (the contaminated portion). This was done to ensure that the groundwater flow of the model realistically approximated the actual aquifer system. The flow model had to be large so that when it was simulated it can reach equilibrium correctly without being bound and constricted by the boundary conditions. The source and zone of contamination were placed in the center of the model so that the local hydrogeology could be represented accurately when the entire region was calibrated. All the ponds neighboring the contaminated area, Snake, Week's, Peter's, Wakebe and Mashpee Pond, were included in the model because of their effects on the configuration of the water table. In addition, it was considered important to have the ponds as part of the model in order to analyze the effects of the plume migration on the regional water bodies.



FS-12 is located almost on top of the water table mound, resulting in the local flow to depart in a radial manner from the highest point of the divide. After descending from the top of the water table, the flow was determined to be primarily north to south. Generally this produces east-west lines of constant head below the contaminated plume. The right and left side of the model were to be bordered by two flow lines starting at the point of divide and flowing thereafter perpendicular to the lines of constant head. Therefore, the flowlines will be north to south, and reach the lower constant head boundary at approximately  $90^{\circ}$  degrees. Because of the lack of detailed information in regard with the mound of the water table, the highest point on the divide was discerned by using both water table elevations and topographical data (LeBlanc et al., 1986; Savoie, 1993). It seemed that the highest portion of the water table does not correspond with the highest part of the topography. Consequently, it was decided to infer the position of the point of divide from water level observations (LeBlanc et al., 1986; Savoie, 1993). Since the head gradient was steeper in the northern part of the aquifer, the center of the mound was set closer to the same line of constant head in the North than in the South. Figure 1 shows the extent and layout of the model. The shape of the model's area resembles, somewhat, a rectangular triangle the apex of which is the point of divide, the base is the lower line of constant head and the other sides are the flowlines.

The unconfined aquifer was to be represented vertically in its entirety by using the bedrock as lower confining layer (Oldale, 1969). To represent the full vertical extent of the aquifer in the model was considered important as the flow model was to be used for plume migration prediction and for the design of the extraction well fence. The flow field in the vertical direction was to be analyzed to determine the effect of pumping on the local flow system. Moreover,

Discretization in the vertical was given importance since the data (Advanced Sciences, Inc., 1993) showed the plume is dipping down in the aquifer.

### **3.2 Discretization**

The model area is defined by the tetrahedral elemental grid. Each element is used in the calculation and simulation of flow parameters, such as head values and velocity vectors. The finite element method approximates reality by averaging the values of each node for each element. Thus a greater elemental Discretization, larger quantity of smaller elements, produces more precise and accurate flow parameters. The grid elements were made smaller and denser in areas of most concern where the flow simulation had to mimic reality as closely as possible. These zones correspond to the locations containing the contaminated region, the source area, the position where the aquifer test was performed, and the location of the proposed well extraction fence (Figure 2).

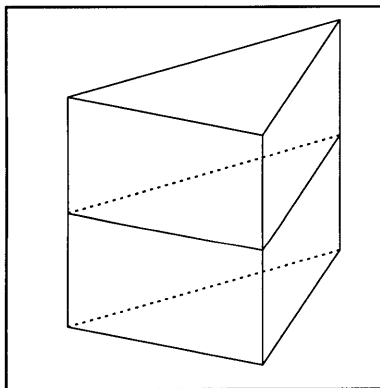

The element is a three dimensional object that forms a tetrahedral. It is defined in the plan view by the grid that connects nodal points to form triangles; in the vertical it is characterized by layers at different depths. Each layer is bounded by two levels of nodes that correspond to the same nodal points of the planar grid. Each of the levels can vary

and cover various elevations. In the model developed, 9 layers were created to both create higher Discretization in critical parts of the study area and to properly configure the various soil layers (Figure 3).

### **3.3 Boundary Conditions**

The model grid area was characterized by three types of boundary conditions: fixed-head nodes, rising water nodes and no-flow boundaries. As mentioned above, the elemental grid is bordered by two flowlines on the left, right and upper side, and by a line of approximately constant head in the bottom. According to the data available on water level elevations, the line of constant head in the lower part of the grid area is not exactly parallel to the border of the model. Therefore, the nodes on the bottom perimeter of the grid were set to be a fixed-head boundary with values ranging from 40 feet mean sea level (MSL) to 4 feet MSL (Figure 4). The perimeter delimiting the left hand side of the grid was set to be a no-flow boundary. In the right hand side some of the nodal points lie along the perimeter of three ponds, Peter's, Wakeby and Mashpee pond. Therefore, the nodes corresponding to the ponds' borders were set to have a fixed-head value equal to each pond's average water elevation, plus an extra foot. From the geological and stratigraphy maps (USGS., 1974; LeBlanc et al., 1986; Savoie, 1993) it was found that the water elevations of the ponds vary from several inches to few feet throughout the year. Consequently, the additional one foot was added to the average ponds' surface elevation to accommodate and account for possible increases, above the average, of the water height within the ponds' area. The head values of the nodes comprising Peter's pond was set at 70.5 feet MSL; the ones for Wakeby pond at 58.0 feet MSL; and for Mashpee at 58.0 feet MSL. The nodes between Mashpee pond and the lower part of the grid were defined as fixed-head boundaries. The water level observation provided good information regarding the water table elevations in this area and the nodal head values were assigned accordingly. The remaining portion of the grid's right perimeter was made a no-flow boundary. All other nodal points contributing to the grid area, including the ones containing the ponds, were specified to be rising water nodes. Rising water nodes are characterized by allowing the water table elevation

to be greater than the ground-surface elevation. If the water level is actually higher than the land surface, the model will set the water table height equal to the ground elevation. In addition, the node(s) involved will be specified by the program as "invoked nodes" or nodes with outflows. The nodes corresponding to the ponds' areas were not set as fixed head nodes. They were, however, specified as rising water nodes because, as previously mentioned, the ponds' surface water variation is quite high through the year and an exact constant value cannot be specified. In addition, the region modeled does not contain any surface water discharge such as streams. Therefore, specifying rising water condition for the ponds' nodes was deemed appropriate to determine exact values of the ponds' water surfaces and to compare these to the average water table elevations. Additionally, the rising water boundary conditions would allow for the simulation of a calibrated water table without necessary production, by the model, of outflows. The configuration of the ponds' elements would enable the analysis of the water level variation, if present in the model. Furthermore, rising water nodes were used to determine the effects of the contamination on the ponds as needed by other studies (Triantopoulos, 1996).

### ***3.4 Soil Layers and Material***

As introduced in the discretization section, the elemental grid of the model for FS-12 is composed of 9 layers and 10 levels (Figure 3). The levels define both the three dimensional elements and the layers. The top level, level 10, corresponds to the ground-surface. Various points from topographical maps (USGS, 1974) were used to interpolate and determine the ground-surface topography to be used in the model. The ground-surface's highest and lowest elevations are 200.0 feet MSL and 50.0 feet MSL respectively. The lowest level, number 1,

defines the confining layer of the aquifer. Because of the extreme depth of the aquifer, complete data were not available on the actual lower boundary of the unconfined aquifer. Various investigations and experts have proposed two views in this regard: the first suggest that there is a deep clay layer occupying the majority of the aquifer and this is the actual confining layer; the other view indicates that the real confining layer is the bedrock existing below Cape Cod (HydroGeoLogic, Inc., 1994; Advanced Sciences, Inc., 1993). Because there are only a few observations that have gone deep enough to reach the clay layer, there is not sufficient information on its exact depth and extent. However the bedrock has been mapped by seismic studies that produced satisfactory data on its configuration (Oldale, 1969). It was thus decided to make the bedrock the confining layer of the aquifer being modeled. The bedrock covers depths between 82.0 and 330.0 feet below MSL. The 9 layers characterize the different types of soil and hydraulic proprieties of the aquifer.

The aquifer soil can be subdivided in three major soil types: upper sand, lower sand, and lower finer sand as shown in Figure 5 (Masterson and Barlow, 1994; Advanced Sciences, Inc., 1993). The 9 layers of the model can be thought of as being sub-layers of the three major layers corresponding to the principal soils. It was also found that the aquifer contains several clay/silty lenses in the medium sand layer. The medium sand layer was built to contain 4 sub-layers, layer 3 - 4 - 5 - 6, to account for the clay/silty lenses and to provide greater discretization in the contaminated zone and in the location of the proposed pumping fence. The lenses were represented by specifying different materials' properties for the elements corresponding to their position in the aquifer. Directly below the ground-surface, level 10, an additional level, level 9, was provided to represent the water of the ponds. The height of this layer, between level 10 and 9, was the average of the ponds' depths, approximately between 20.0 and 30.0 feet. The

elements of this layer corresponding to the triangles covering the ponds in plan view were assigned a high conductivity "water" material. The water of the ponds was specified as a highly conductive material to analyze, as mentioned above, the variation of the water surface height within the ponds. An additional level, level 8, was introduced to represent the sediments underlying the water of the ponds. The sediment material was therefore located between level 8 and 9 and was given a thickness of about 10 feet.

In general, the hydraulic conductivity of the aquifer is very high and it decreases with depth as the types of soil grains become finer (Masterson and Barlow, 1994; Advanced Sciences, Inc., 1993). The clay/silty lenses, however, show drastically lower conductivity, from about 95% to 35% lower. The conductivities of the various soils were assigned according to both the results of the local aquifer test (HydroGeoLogic, Inc., 1994), for the FS-12 plume, and the data for the entire Western Cape Cod aquifer (Masterson and Barlow, 1994). The hydraulic conductivity magnitudes and values depend on the size of the area being tested as they are an average over the particular region. Due to this dependence and because the aquifer is very heterogeneous, the regional and local hydraulic conductivities can be very different. The portion of the aquifer being modeled is larger than the local aquifer test area and at the same time much smaller when compared to the entire aquifer. As a result, the hydraulic conductivities used in the model were determined, in certain instances, to be quite different from the one suggested by the available data.

As mentioned above, one of the three major soil types of the aquifer was defined as upper sand. This is a highly conductive soil with coarse grained sandy characteristics. The medium sand is very similar to the upper sand, but it has slightly finer grains and thus a slightly lower

conductivity. The major layer that is characterized by the medium sand also contains clay/silty lenses located east of Snake's Pond. The lenses, as already stated, have much lower hydraulic conductivity. Below the medium sands the soil is composed for the most part of finer sand and of silty glacial deposits. However, not sufficient and adequately deep observations have been made to determine the precise quantity and spreads of these glacial sediments. For this reason and because it is believed that these silty deposits have virtually no effect on the aquifer flow, it was decided to model this layer as one homogeneous material. The quality of this homogeneous soil was defined as finer sand with lower hydraulic conductivity than in the sandy soils above. The material adopted for the pond's water configuration was defined to be ideally 100% conductive. The conductivity of the sediment material was originally set at a value of virtually no conductivity (1.0). However, when the conductivity of the ponds' sediment material was set equal to that of the upper sand, the simulated model did not show any significant change in the flow field characteristics. Therefore, the sediment material's properties were specified to be equal to those of the upper sand characterizing the substrate of the modeled aquifer. The conductivity was specified to be the same in the longitudinal and transverse horizontal axes (Advanced Sciences, Inc., 1993, Masterson and Barlow, 1994). The ratio of horizontal to vertical conductivity was determined to be 3:1 for the entire Cape Cod aquifer (Masterson and Barlow, 1994). Since it was found that changing this ratio did not affect the flow simulation, the horizontal to vertical conductivity fraction was established to be 3:1 for all materials of the local area being modeled. Following the same line of reasoning, the storage and transmissive properties for the various materials were selected in accordance with both the characteristics of the entire Cape Cod aquifer and with the specific type of soil that the particular material represented. As previously mentioned, both local aquifer test data and values for the entire Western Cape Cod aquifer were used in the determination of the

conductivity for each material. Consequently, an exact and unique value of conductivity could not be determined. The local aquifer test and the data of the Western Cape Cod aquifer indicated that: the sands closer to the surface had conductivities ranging from approximately 200.0 to 300.0 feet/day, and the lower soils could reach conductivities as low as 100.0 feet/day. The model was simulated a large number of times with different values of hydraulic conductivities for the various materials. From the simulations results it was determined that changing the conductivities in the soil layers by +/- 20% did not have a very large effect on the flow field calibration. Therefore, the actual values used in the final model for the various layers of the model are as follows:

	Upper Sand	Medium Sand	Lower Sand	Clay/Silty Lenses	Sediment Material	"Water" Material
Horizontal Hydraulic Conductivity (ft/day)	355	275	50	19	355	100,000
Vertical Hydraulic Conductivity (ft/day)	118	92	17	6	118	100
Specific yield (unitless)	1X10 <sup>-1</sup>	1X10 <sup>-1</sup>	1X10 <sup>-1</sup>	1X10 <sup>-1</sup>	1X10 <sup>-1</sup>	1X10 <sup>-1</sup>
Specific Storage(1/ft)	0.2	0.2	0.2	0.1	0.2	1.0

According to the studies performed by Masterson and Barlow (1994) the average value of rainfall recharging the aquifer is 23 inches per year. This value of recharge was used in the model and it was assigned to be constant over the entire grid area.



## **4. PLUME MIGRATION MODEL**

The groundwater model created for the simulation of natural flow was used in the determination of the plume migration. The model of the plume consisted of creating the particle tracking to represent the movement of benzene, one of the contaminants at the FS-12. The following will explain in detail the inputs and creation of the particle tracking.

### ***4.1 Particle Tracking***

The particle tracking consists of creating a source input of particles in a particular location of the existing groundwater flow model, and observing their travel through the aquifer. The model is then simulated for a specified period of time. During the time of simulation the particles are “tracked” for the determination of their positions through time. The results of the simulation should show the particles’ locations at the end of the time period. The travel time and path the particles take depend on chemical and physical properties of both the contaminant the particles represent and of the aquifer soil. The principal processes that affect contaminant travel as modeled by DYN-TRACK are: decay, dispersion and soil porosity. The travel time through the unsaturated zone will be ignored since it is on the order of days as opposed to years when compared to the time of travel through the saturated aquifer. Of the contaminants present at FS-12 (ethylene dibromide or EDB, and benzene, toluene, ethylene and xylene, together known as BTEX) only benzene was modeled. This was decided because of the relatively higher concentrations of dissolved benzene present with respect to the other contaminants. Benzene was also chosen because it is the least retarded of the contaminant present and it has

the lowest bio-degradation rate. The mobility of the pollutant increases as the retardation decreases, while relative concentration increases as the biodegradation rate decrease. Consequently, the worse case scenario can be modeled by using benzene.

The free product of FS-12 was modeled as a continuous source because of the large quantities of contaminants and the slow solubility of benzene into the dissolved phase. It was thus assumed that the benzene's concentrations at the free product's interface are equal to its solubility.

#### **4.2 Data Inputs**

The particles were thus introduced as a constant source in the same area of the present pool of free product (Figure 6). The time period for the simulation was chosen to be only 10 years long. The physical property of the benzene input for the model's simulation was its decay rate defined as half life and equal to 720 days in groundwater (MacKay, 1992).

To define how the aquifer soils layers affect the travel and flow of the benzene, additional material properties were entered. As mentioned above, the soil characteristics greatly determine the travel time and flow. The physical properties of soil of most interest are dispersion and effective porosity. Dispersion varies and is defined over the three orthogonal directions, longitudinal, transverse and vertical. This soil characteristic is highly scale dependent (Gelhar, 1992). For the model definition, however, measurements of dispersivity for the entire Cape Cod aquifer had to be used because of the lack of information regarding the local FS-12 area (Masterson and Barlow, 1994). Effective porosity also influences the flow of

contaminants (Domenico and Schwartz, 1990). These properties were set equal for all types of soil defined in the model configuration of soil layering and materials (except for porosity that was only equal for only the three types of sand). It was decided to keep the same values for two reasons: first it was considered more accurate to use the same property for all layers and materials rather than guess unknown values. In addition, it was found that the types of soil at the site did not greatly differ from one to the other. This was determined by actually trying to simulate the model with different dispersivity for various soil types, and observing that the particle tracking results were not significantly changed. The following table shows the final soil and benzene characteristics inputted into the model for particle tracking:

	Upper Sand	Medium Sand	Lower Sand	Clay/Silty Lenses	Sediment Material	"Water" Material
Horiz. Longit. Dispersivity (ft)	40	40	40	40	40	40
Horiz. Transv. Dispersivity (ft)	10	10	10	10	10	10
Vertical. Dispersivity (ft)	0.33	0.33	0.33	0.33	0.33	0.33
Effective Porosity	0.39	0.39	0.39	0.1	0.39	1.0
Benzene Half Life (days)	720	720	720	720	720	720

## **5. WELL EXTRACTION FENCE DESIGN**

The groundwater model built for the flow in the area of FS-12 can also be used for the simulation of transient flow. The well extraction fence, for the control and containment of the plume, was designed by using the groundwater model capabilities of simulating flow under pumping conditions and of analyzing the flow at different periods in time.

### ***5.1 Aquifer Test Duplication***

A field aquifer test was performed below the toe of the FS-12 to determine the hydraulic characteristics of the local soil for future use in remediation and/or containment (HydroGeoLogic, Inc., 1994). To determine that it was appropriate to use the groundwater model for the design of the extraction fence the aquifer test done in the field was reproduced. To execute the pumping test on the model the node corresponding to the location of the production well was specified to have an outflow equal to the one used in the real life test, 400.0 gpm. For the nodes equivalent to the position of the observation wells (Figure 7) a log of the drawdown over the actual length of the aquifer test, 72 hours, was recorded in a time step of 1.44 minutes. The model was then simulated under transient conditions and the resulting drawdowns at the "observation" nodes were compared to the actual drawdowns measured in the field. For wells close to the production well, the comparison was made by constructing diagrams using the Theis Modified Non-Equilibrium Time-Drawdown Method as it was done in the analysis of field results (HydroGeoLogic, Inc., 1994). A typical drawdown response of an observation well for both the actual and model tests are shown on Figure 8.A and 8.B

respectively. The drawdowns resulting from the aquifer test duplication using the model were generally slightly lower than the field records showed. However, the slope of the graph of drawdown versus time produced during the model's aquifer test was approximately equal to the one obtained in the field test. The slope is a measure of aquifer response to pumping. Consequently, the fact that the slope of the model is consistent with the actual one is to sign that the groundwater model is properly designed. It was thus decided that the model is suitable to be utilized in the design of the well extraction fence.

## ***5.2 Location and Extent of Plume to be Contained***

The first step in the design of an extraction well system for the control of the plume is to determine the extent of the actual contamination and the location at which this should be captured. Therefore, the wells' records showing the location of the plume as well as its concentration were analyzed and the position of the contaminated groundwater to be controlled was determined (Figure 9, 10.A and 10.B). The plume was defined as being composed of EDB and BTEX since the well extraction fence was designed for the capture of both pollutants. The contaminated area is approximately 5,000 feet long and approximately 2,300 feet in its widest portion. It was found it extends in the upper portion from the top of the water table to about 0 feet MSL. Down-gradient, however, it dips down covering a vertical spread between 25 feet MSL and 65 feet below MSL.

## ***5.3 Well Fence Placement and Layout***

The actual plume consists of contaminants dissolved in the groundwater that move at the same velocity and in the same direction of groundwater flow. Therefore, to properly contain the

plume, the actual volume of groundwater flow occupied by the contamination had to be captured. It was determined that the well fence should approximately surround the contaminated zone below the toe of plume. This was to ensure that the entire volume of flow containing the dissolved contaminants would be completely captured by the pumping wells. The critical point of the design was to prevent the contaminated water from trespassing the well extraction system and flow uncontrolled through the rest of the aquifer.

The groundwater flow at the end of the plume has a South-Easterly direction as shown by Figure 11. To capture the flow volume containing the contaminants, it was decided to place the well fence approximately perpendicular to the direction of flow and parallel to the lines of constant head (Figure 11). In addition, the extraction fence was to be more horizontal as it approached Snake Pond because of the effects the pond has on the aquifer flow at this location.

It was found that many possibilities existed in regard to the exact layout and shape of the well fence and the number of wells to be used. Therefore it was decided to test different well fence layouts with various numbers of pumping wells. The goal was to build an efficient system. It was established that the final design would be a "trade off" between: the number of wells, the total pumping rate, and the depths of the wells' screening intervals on which drilling costs would depend. The analysis of different systems was based on an optimization method. Once a particular fence layout was chosen, various systems with different number of wells were analyzed and simulated. For each system, consisting of a particular set of wells, the minimum required pumping rate for complete capture of the plume was determined through various simulations. Consequently, a set of different well fence systems with respective minimal

pumping rates could be obtained. These results were plotted on a graph of pumping rate versus number of wells to establish the boundary of the minimum number of wells and rates required for effective plume's containment, as shown in Figure 19. The line connecting the systems of wells with corresponding rate determines the optimal, minimum pumping rate for a given number of wells and vice versa. The zone above this line indicates systems that completely but not efficiently capture the contaminated water. However, systems below the optimal line will not contain the plume effectively.

In addition, a cost analysis of the optimal well fence systems was performed. The results of the cost analysis would help in establishing the most effective system comprising of a particular number of wells and respective total pumping rate. For each optimal system the initial drilling costs and the electric energy costs were investigated. Drilling costs depends, and generally increase, with the depth of the screen and the number of wells. A base capital cost of \$160.00 per foot of well drilled was used for the first 8 wells drilled. Any additional well was assumed to have a cost of about 55% of the base cost. This was assumed to approximately replicate the real life cost savings per well when a higher number of wells is drilled. However, the electrical costs to operate the pumps depend on the magnitude of the pumping rate and on the magnitude of the head the water has to be lifted. The power,  $P$ , in kilowatts (kW) required for a system of wells was determined by:

$$P = \frac{QH}{2,953.02}$$

where  $Q$  is the total pumping rate in gpm;  $H$  is the head the water has to be lifted in feet; and 2,953.02 is a combination of conversion factors. Using the power, the energy cost could be obtained by applying a rate of \$0.10/kWhr. The results of the cost analysis were plotted to

determine, from the set of optimal systems, the combination of number of wells and respective flowrate with the minimum cost of construction and operation. A graph relating the annual electrical energy costs and the number of wells was first constructed. Additionally, plots of total costs for drilling and electrical energy versus number of wells were developed for different numbers of years. This graphs would allow to evaluate the weights and the correlation between the two types of costs involved, drilling and electrical energy. The costs cash flows were computed by present value analysis with an interest rate of 8%.

#### ***5.4 Design Method: Capture Curves***

To actually test and analyze the results of the various designs the groundwater model was utilized. To determine its position in space and time, the volume of contaminated groundwater was represented by visible particles. They exemplify and render visible the groundwater as it flows through the aquifer. The particles can be started at a selected location and analyzed in space and time by selecting the desired time step. By analyzing the position of the particles it is possible to determine the exact flow path of a particular volume of groundwater. The particles can be placed so that their location corresponds to the contaminated water. Consequently, when the model, containing the extraction well fence, is simulated it is possible to determine whether the flow volume of the plume, as represented by the particles, is captured by the wells.

The cross section chosen for the particle tracking of the FS-12 plume is shown in plan view in Figure 9, and in the vertical in Figure 10.A and 10.B. As displayed by the figures some of the particles were chosen to be out of the actual contamination. This was done to ensure that the contaminated water was captured completely, and to also design an efficient extraction fence



that does not pump more than the required volume of water. In plan view additional particles were included: three on the right side and four on the left side where Snake pond is. In addition, in the vertical cross section, flow particles were included above and below the actual plume's location. The spacing between the particles in the horizontal was about 200 feet, while in the vertical it ranged from 10 feet in critical points up to 20 feet. In the vertical the particles were spaced so that the vertical extension of the extraction wells capture curves could easily be determined.

Each pumping well was defined in the model by the corresponding nodal point with the same coordinates. The nodes representing the extraction wells were assigned an outflow equal to the pumping rate proposed for the particular well. The model was then simulated under transient conditions to analyze the flow and determine if the extraction well fence actually captures the volume of contaminated water. The efficacy of the well fence design and layout was evaluated by obtaining the capture curve for the well layout being tested. The capture curves were determined by analyzing which and how many of the flow particles were being captured by the wells in the simulated model. This analysis could be done both in plan and vertical view to properly define the capture curves in three dimensions.

## **6. COMPUTER MODELING RESULTS**

The groundwater model was built to analyze the natural, current, flow of the local area where FS-12 is located. In addition, the computer model was utilized to predict and examine the migration of the contaminated plume by performing a particle tracking analysis. The results of the natural flow field were also applied for the design and simulation of the well extraction fence. The findings and results of the modeling of FS-12 are described and explained below.

### **6.1 *Natural Flow***

The elemental grid with appropriate hydraulic properties and soil layers was used for the simulation of the natural flow field for FS-12. To determine the accuracy and correctness of the model the hydraulic head values produced by the simulations were compared with the observed water level elevations (Savoie, 1995). The flow field generated by the model resulted in a mean difference (calculated minus observed) between the simulated and actual head values of -0.348 with a standard deviation of 1.687 (Figure 12). In the area of interest, where the source and plume of contaminants are located, the simulated water levels in the wells were only few tenths of a foot less than the observed values. This was considered an acceptable difference. The elevations of water table vary on average 3 feet per year (Masterson and Barlow, 1994). Thus, small differences between simulated and observed head could have been attributed to seasonal variations in water levels. In addition, the head values in the wells located down-gradient of the plume are satisfactorily close to the real values. The major differences in head, which increased the standard deviation, occurred north of the contaminated area. The heights

of the water table in the ponds' elements from the simulated model are nearly equal to the yearly average values observed for the ponds' water surface elevations (Savoie, 1995).

	Snake Pond	Mashpee Pond	Wakeby Pond	Peter's Pond
Observed (feet MSL)	68.09	57.08	57.08	68.56
Simulated (feet MSL)	67.91 - 68.13	56.44 - 56.96	57.04 - 57.31	67.52 - 68.44

The model was constructed such that the actual surface elevation in the water bodies was one foot higher than the observed to accommodate seasonal variation without producing outflows, as explained in the Boundary Conditions section. In fact the model displays the water table to be slightly lower than the actual surface height of the element representing the pond (Figure 13 shows a cross section of Snake Pond).

Since groundwater movement is perpendicular to the lines of constant head, the general flow pattern was determined to be north to south. In the right hand side of the modeled area, where the majority of the ponds is situated, the flow takes a slight south-easterly direction. This occurs because of the long vertical series of water bodies whose water surfaces are characterized by constant hydraulic head. It is possible to discern that the flow from the contaminated region will move in a south-easterly direction (Figure 14.A and 14.B). In addition, it can be seen that the contaminated volume of water would flow and reach the left bank of Mashpee and Wakeby pond if left under natural conditions (without pumping). The water table mound can be observed on the top of the grid area. Close to the mound the flow-lines are very concave and the flow vectors are positioned radially as they move away from the point of divide (Figure 14.A). The correctness of the flow field can be further evaluated by noting that the lines of constant head cross the grid's no-flow boundaries perpendicularly.

## **6.2 Contaminant Migration**

The groundwater model was used for the simulation of benzene particle tracking. The results of the simulation are shown in plan view in Figure 15, and in a longitudinal cross section in Figure 16. Compared to the observed values the results from the simulation present two types of inconsistencies. The first is related to the distance traveled by the contamination for a period of time. The simulation was performed for a 10 year period. However, it produced a plume with approximately the same extension as the current contamination that is the results of about 20 years of spreading. Since the shapes of the simulated and actual contaminated area are nearly equal in plan view, it can be discerned that there is a difference of a factor of two in the travel time. However, the fact that the plume's positions and extent are similar shows that the flow field configuration is correct. The fact that accounts for the difference in travel time between simulated and real condition is the horizontal velocity of the groundwater.

The second inconsistency is related to the vertical position of the simulated plume. Figure 17 displays the simulated and actual extent of the contaminated water in a longitudinal cross section. The plume resulting from the model is shallower than the observed contaminants in the field. As shown, the real plume is about 25 feet deeper than the simulated one. This difference probably dues to the variance in vertical flow velocity. The magnitude of velocity in the vertical direction depends on the value of the anisotropy ratio. As mentioned before, the anisotropy ratio used for the model's configuration was taken from data for the entire Cape Cod aquifer. Therefore, it is highly possible that the local ratio of horizontal to vertical conductivity is different from the average over the whole aquifer. In addition, both inconsistencies can probably be traced to the same cause. While the flow field was properly represented (as displayed by the water table elevations), the vertical and horizontal velocities were too low and

too high respectively. It is therefore possible that the velocities are interdependent. It is believed that if the vertical velocity is increased by a particular value, a comparable decrease in the horizontal velocity can be observed. The most probable cause for inaccuracies in the magnitudes of the velocities is the position of the point of divide. It is believed that if the highest point in the mound is set lower, the flow velocity will be decreased in the longitudinal direction and increased in the vertical. It is also presumed that the flow field would not change significantly in the case the point of divide would be moved toward the spill.

### ***6.3 Extraction Well Fence Containment System***

The final extraction well fence designed with the aid of the groundwater flow model consisted of 11 well pumping a total of 800 gpm. After several trials, the best fence layout was determined to enclose the toe of the plume by surrounding almost exactly the contour of the lowest detectable level of contamination. As Figure 18 displays, most part of the fence, on the right, is positioned perpendicularly to the direction of flow which is directed toward South-East. As the well fence approaches Snake Pond on the West side it is more concave and slightly curved upward to ensure the plume is properly contained around the pond's shore.

The number of wells was chosen to be 11 according to the simulation results of different systems with various numbers of pumping wells. The minimum required pumping rate for complete containment of the contaminated water was found from several different simulations to be 800 gpm. A graph relating the number of wells to the respective required pumping rates of wells is shown in Figure 19. As displayed by the plot, the required flow rate for complete plume's capture decreases faster than the number of wells increases. The pumping wells draw

groundwater flow volume from all directions. Therefore, their influence can be thought of, in three dimensions, as a sphere surrounding the screening interval. It was ascertained that the vertical radius of the sphere of influence was much lower than the radius of influence in the horizontal transverse direction. This observation is consistent with the anisotropy specified for the model: the vertical conductivity is a third of the horizontal, longitudinal and transverse, conductivity. Figure 20 displays the contours of constant head produced by the pumping well after the simulation of transient flow. As shown, the head gradient is greater in the horizontal signaling a greater horizontal radius of influence. Therefore, two principal observations were made from simulations of various well pumping systems. First, the limiting factor for the pumping rate to effectively capture the plume was the size of the well sphere of influence in the vertical direction, or the vertical radius of the zone of influence. This was believed to be dependent on the fact that vertical conductivity is much lower than the horizontal since the anisotropy ratio is 3 to 1 (Masterson and Barlow, 1994). The simulations also indicated that having a deeper screening interval would allow a lower flow rate. This depended on the stratigraphy of the local soils and the fact that the lower part of the plume is actually located in a lower conductivity region. Consequently the radius of influence of the pumping well would be greater above the screen than below it. It was reasoned that placing the wells deeper into the aquifer would produce a more efficient capture curve for the well fence, and a lower required pumping rate. The screening intervals were found to be most effective when they were placed at a depth ranging from 40 to 70 feet below MSL. These depths approximately corresponds to the deepest portion of the plume.

The optimal line in Figure 19 shows that there are several systems of wells and pumping rates that are optimal for the capture of the contaminated plume. However, the results from the cost

analysis indicated that not all optimal systems are the most efficient in terms of construction and operational costs. The relation between annual electrical costs and number of wells is displayed by Figure 21. The plot shows that the system with the lowest flow rate, 800 gpm with 11 wells, has the lowest annual operational costs. Furthermore, it can be seen that the costs produced by 11 wells is approximately the lowest for all the possible optimal systems. It can be inferred that after this point the curve will probably be flatten out. This would indicate that 800 gpm is the required minimum pumping rate to efficiently and completely capture the plume. If the curve becomes actually flatter after this point, a "saturation" value would be reached with respect to the number of wells required for successful capture. This could also occur in Figure 19. At a certain point increasing the number of wells would results in an equal, constant, minimum pumping rate. From the graphs obtained it seems that adding more than 11 wells to the system would not produce a significantly lower rate. Accordingly, an extraction well fence design consisting of approximately 11 wells will be the optimal solution. In addition, Figure 22.A and 22.B show the total costs, initial construction and electric energy costs, as a function of number of wells for a period of 20 and 40 years. The plots display the non linear relation between number of wells and total cost required for usage. It can be seen that there is a trade off between the number of wells with associated drilling costs and the minimum pumping rate with respective electrical costs. The drilling costs are higher for a larger number of wells. However, a greater number of wells implies a lower total pumping rate and therefore less operational coasts. The lowest point on the curve indicates the most efficient system of extraction wells and respective rates both in terms of minimum required pumping and of lowest costs. As shown, the minimum point occurs just after the systems comprising of 10 wells, between 10 and 11 wells. Therefore, 11 wells seemed to be appropriate to provide an efficient design for the containment of the contamination at low costs.

The simulation results of this well fence system are shown in Figure 23.A in plan view, and in Figure 23.B in the vertical. The plan view shows the extent of the well fence capture zone in the horizontal plane. Since three of the particles on the right and four on the left side are not part of the contaminated water, it can be seen that the well extraction fence completely captures the plume. The wells' influence is limited to the volume of water in which the contaminants are dissolved. In the horizontal direction, the wells' capture zone perfectly encloses and controls the polluted water. The wells do not pump unnecessary volume of "clean" water. Clean water is represented by the three and four particles on the sides which are free to flow through the aquifer past the well fence. Similarly, in the vertical cross section the extent of the extraction fence capture curve is approximately limited to the contaminated water volume only. Most of the particles representing the volume of "clean" water surrounding the plume are not captured by the wells.

The minimum pumping rate required for capture of the plume was 800 gpm. Because of its vicinity to Snake pond, the well fence system draws water from the pond into the aquifer. For this reason the pumping rates of the two wells next to Snake Pond were set at 83 gpm each. During the various simulations it was observed that even at low pumping rates (400 gpm) water from the pond would recharge the aquifer. This was found to be consistent with the observations made during the aquifer test (HydroGeoLogic, Inc., 1994). In addition, the simulations indicated that the part of the plume close to the pond could only be captured if water was being drawn from the pond. The remaining wells had a pumping rate of 70.5 gpm each to make up a total extraction fence flowrate of 800 gpm.



## 7. CONCLUSION

### ***7.1 Assessment of Modeling Results***

The groundwater computer model for FS-12 has been very useful for the purposes of analyzing the flow field and plume's movement, and to determine the optimal design for the extraction well fence. In general the flow field simulated by the model was found to represent reality quite closely. This helped in the evaluation of an efficient system for the extraction well fence. However, the model did not properly depict some of the local hydraulic and soil properties. The major gaps in the accuracy of the model are to be found in the improper vertical flow simulation and high heterogeneity in the soil layers. The causes of these inaccuracies depend on many factors. The one most obvious is the time constraint on the model development. If more time was available, better results could be obtained through better calibration and more sensitivity analysis. The configuration and exact location of the water table mound could be better represented by further adjusting the grid point of divide, shape and size. The point of divide is believed to be located closer to the FS-12 plume. If this point is moved lower, there will be an increase in vertical flow which would force the plume to move further in the vertical direction and deeper within the aquifer. Another factor that highly contributed to inaccurate representation of the flow field is the lack of detailed records of soil characteristics deep within the aquifer as well as further away from the contaminated area. Many assumptions had to be made with respect to the geology and stratigraphy of the local soils. As a result a simplified model was employed to describe the heterogeneity and soil type variability of the FS-12 hydrogeology. The most obvious effects of these imperfections were visible in the particle

tracking for the determination of the plume's migration. The groundwater model covered a relatively small area of the actual aquifer. Using average values for the entire Cape Cod aquifer in the model of a small portion of the actual aquifer can, and did, produce some improper results. This is because many hydraulic and soil parameters are scale dependent. Specific characteristics should be measured only over the area that has to be modeled. The model was probably properly and correctly built. Its inaccuracy stemmed from the lack of data and the resulting "forced" choice of parameters that are applicable to the whole aquifer only.

## ***7.2 Recommendations***

It is believed that in future groundwater modeling of the FS-12 region more time should be made available for sensitivity analysis. This would ensure a more accurate representation of the existing flow field. Although there are data gaps with regard to the location of the water mound, it is believed that the water table configuration can be properly determined through more extensive analyses and simulations. Similarly, the lack of detailed information about the geology of the deep soil layers can be overcome by determining the sensitivity analysis.

The most important recommendation for future groundwater models of FS-2 is to create a model of the entire aquifer. This is because it is believed that the effects of the flow field as a whole should be represented to properly determine the local flow and migration of FS-12.

## 8. FIGURES

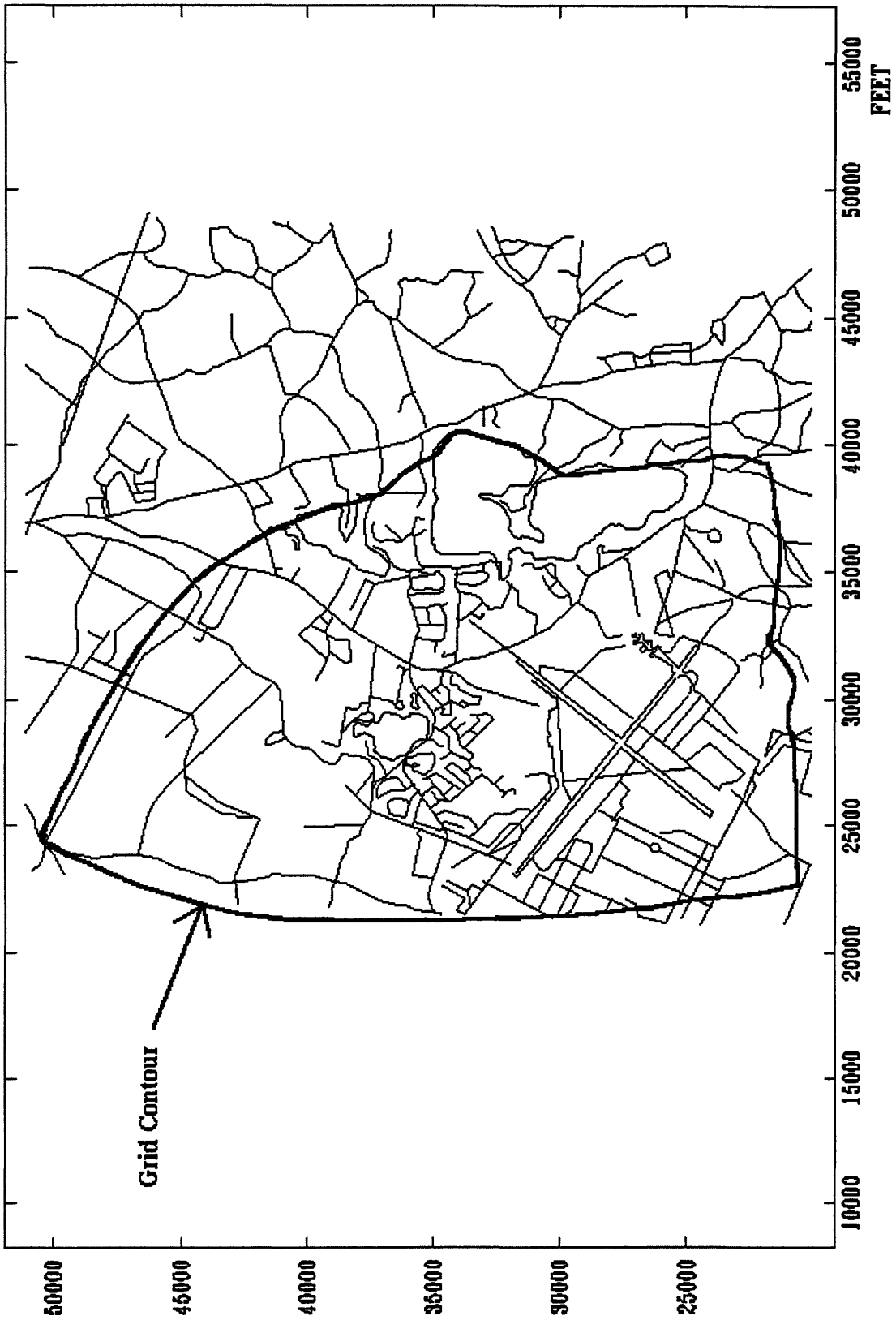

**FIGURE 1 - Study Area Street Map Showing Grid Outline.**

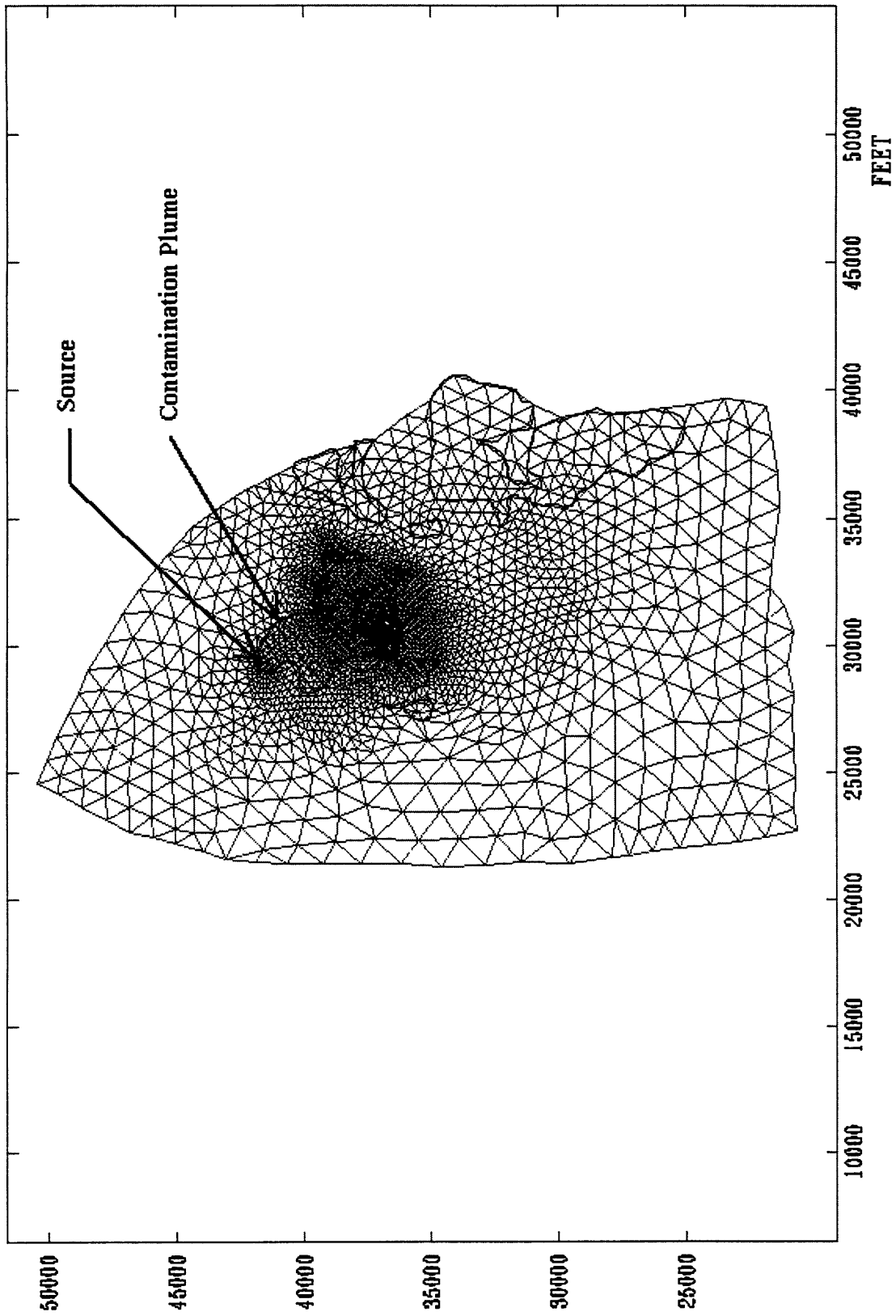
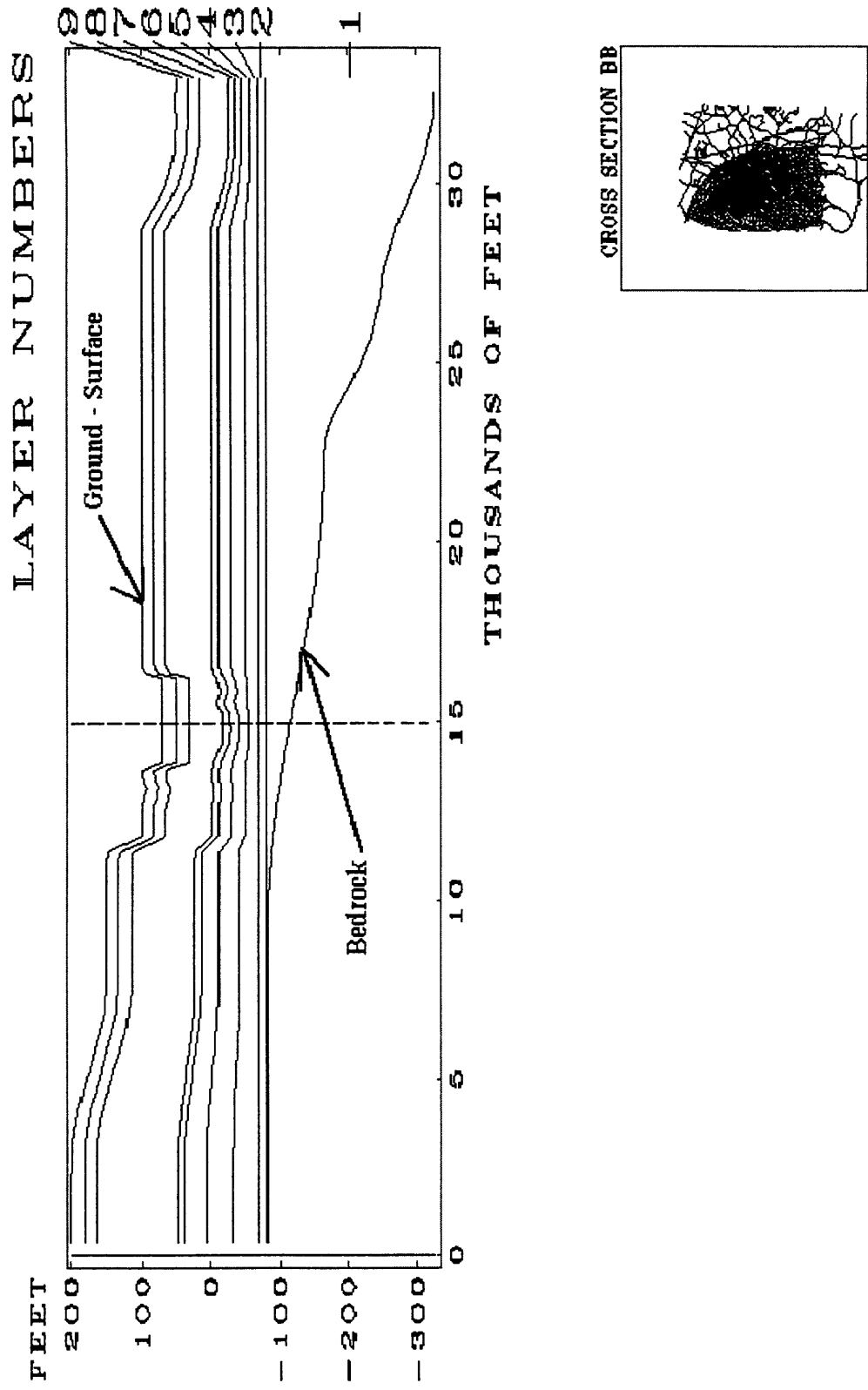
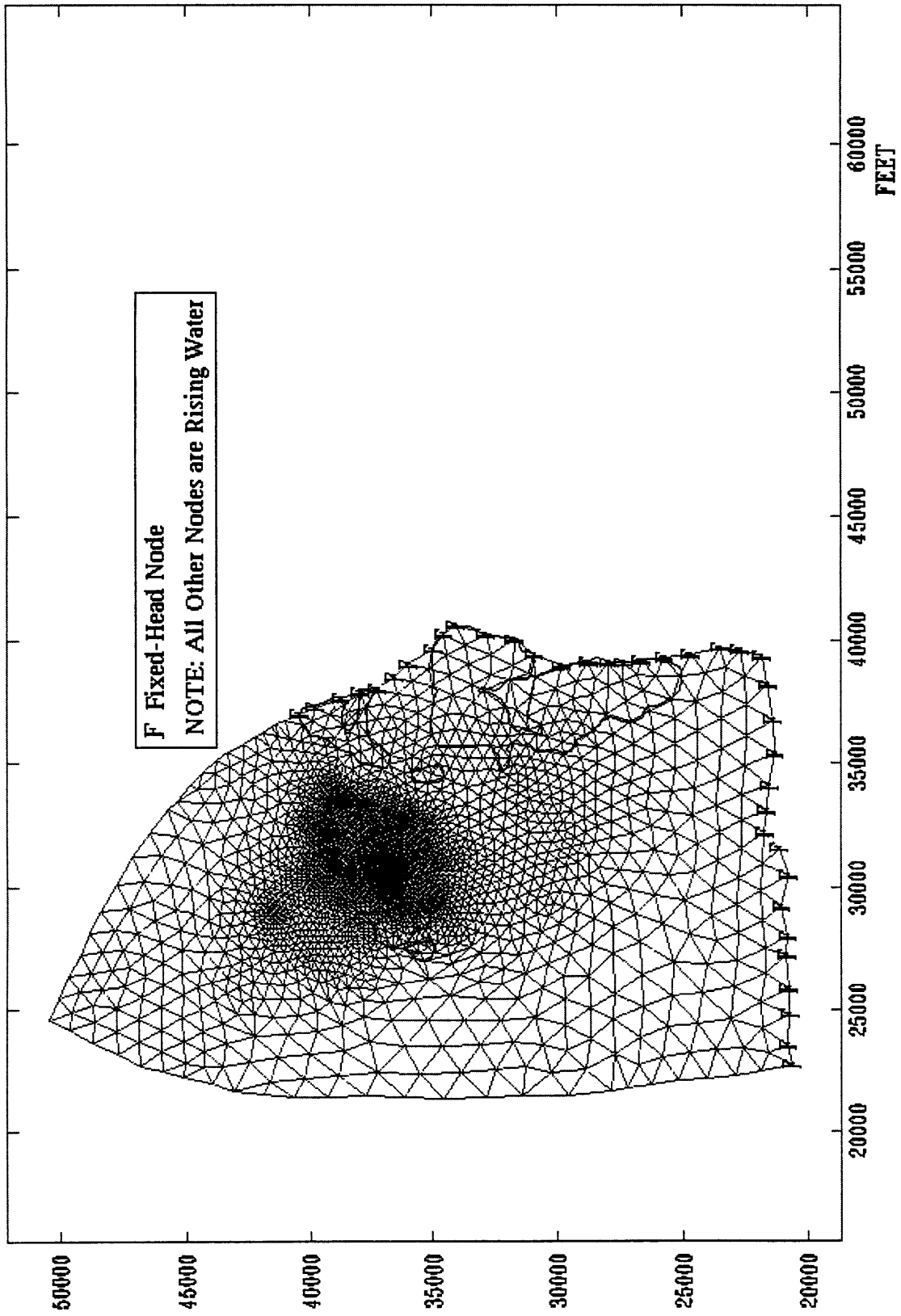

FIGURE 2 - Elemental Grid.



**FIGURE 3** - Longitudinal Cross-Section Showing Levels and Layers.



**FIGURE 4 - Grid Area Showing Fixed-Head Nodes.**

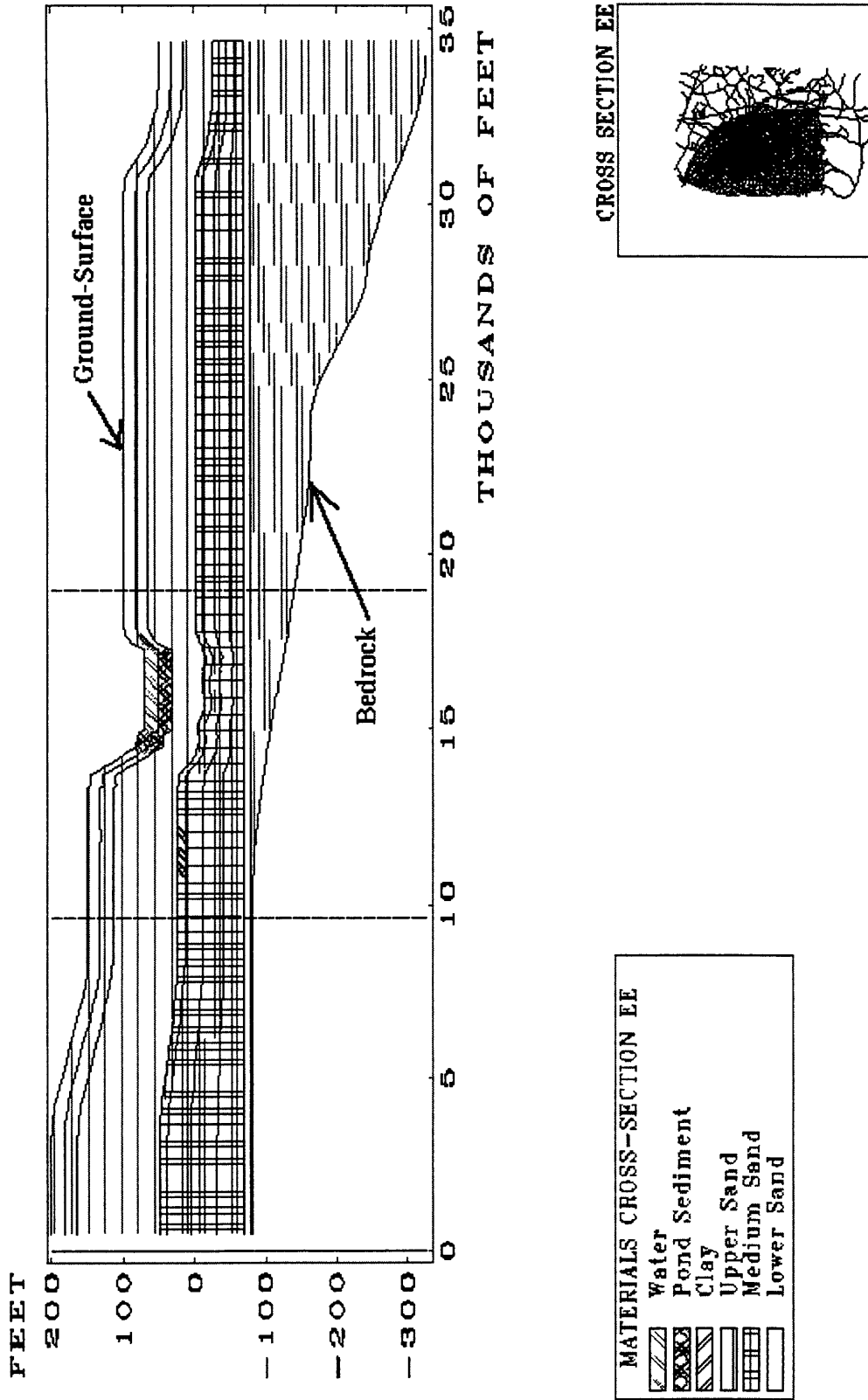

FIGURE 5 - Longitudinal Cross Section with Soil Materials and Layers Showing.



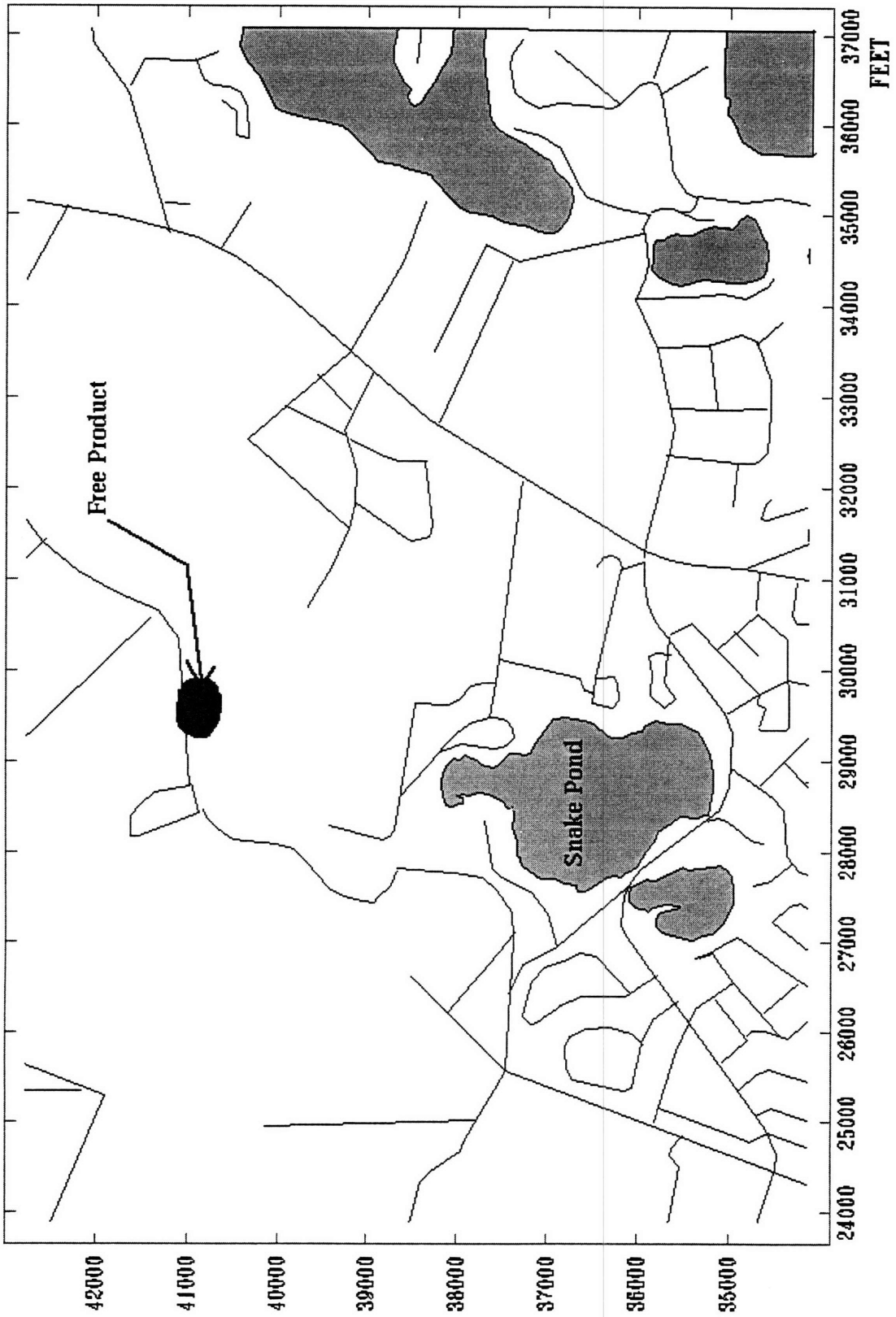

FIGURE 6 - Free Product Location.

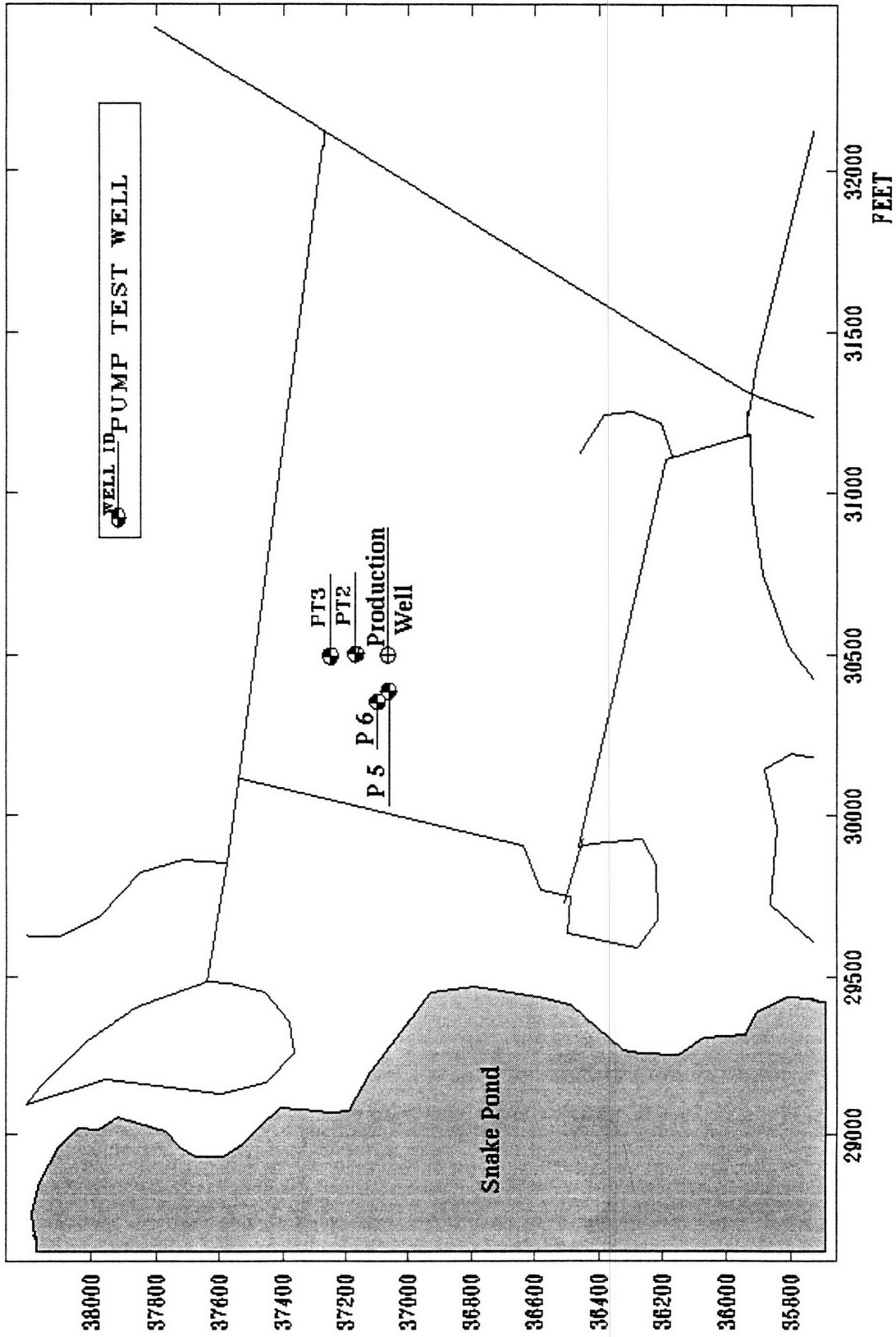
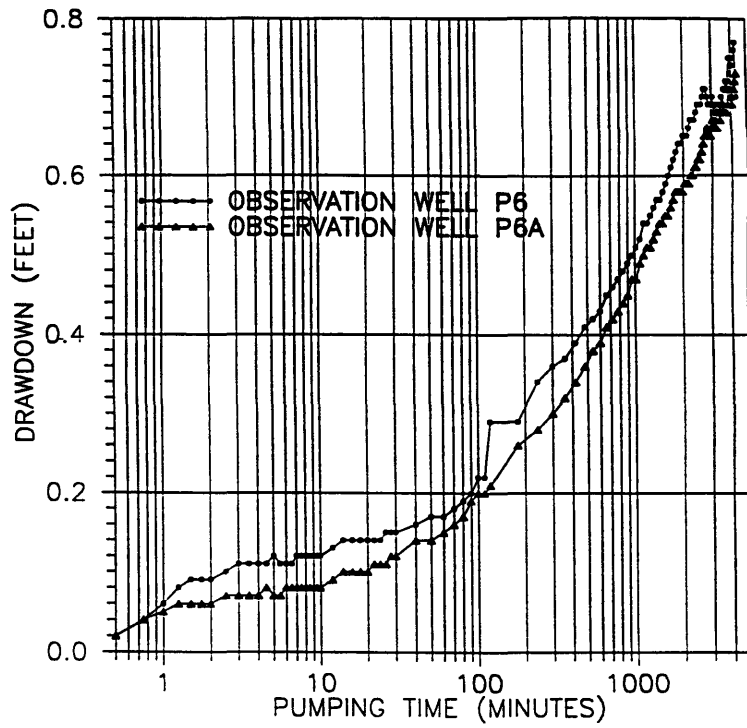
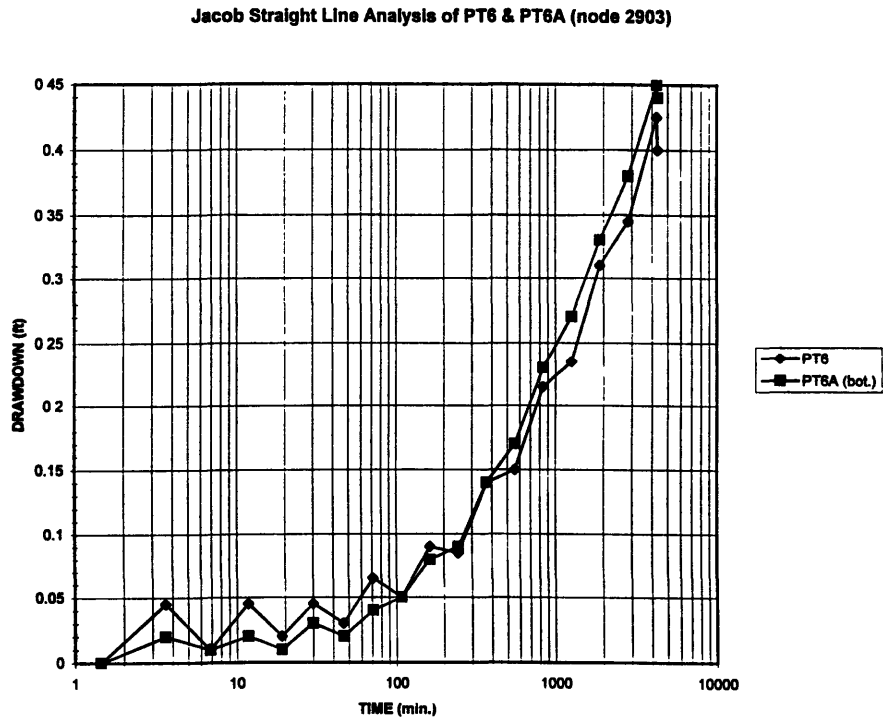

FIGURE 7 - Aquifer Test Observation Wells and Production Well Location.



**FIGURE 8.A - Actual Aquifer Test Analysis by Jacob Straight Line Method.**



**FIGURE 8.B - Model Aquifer Test Analysis by Jacob Straight Line Method.**

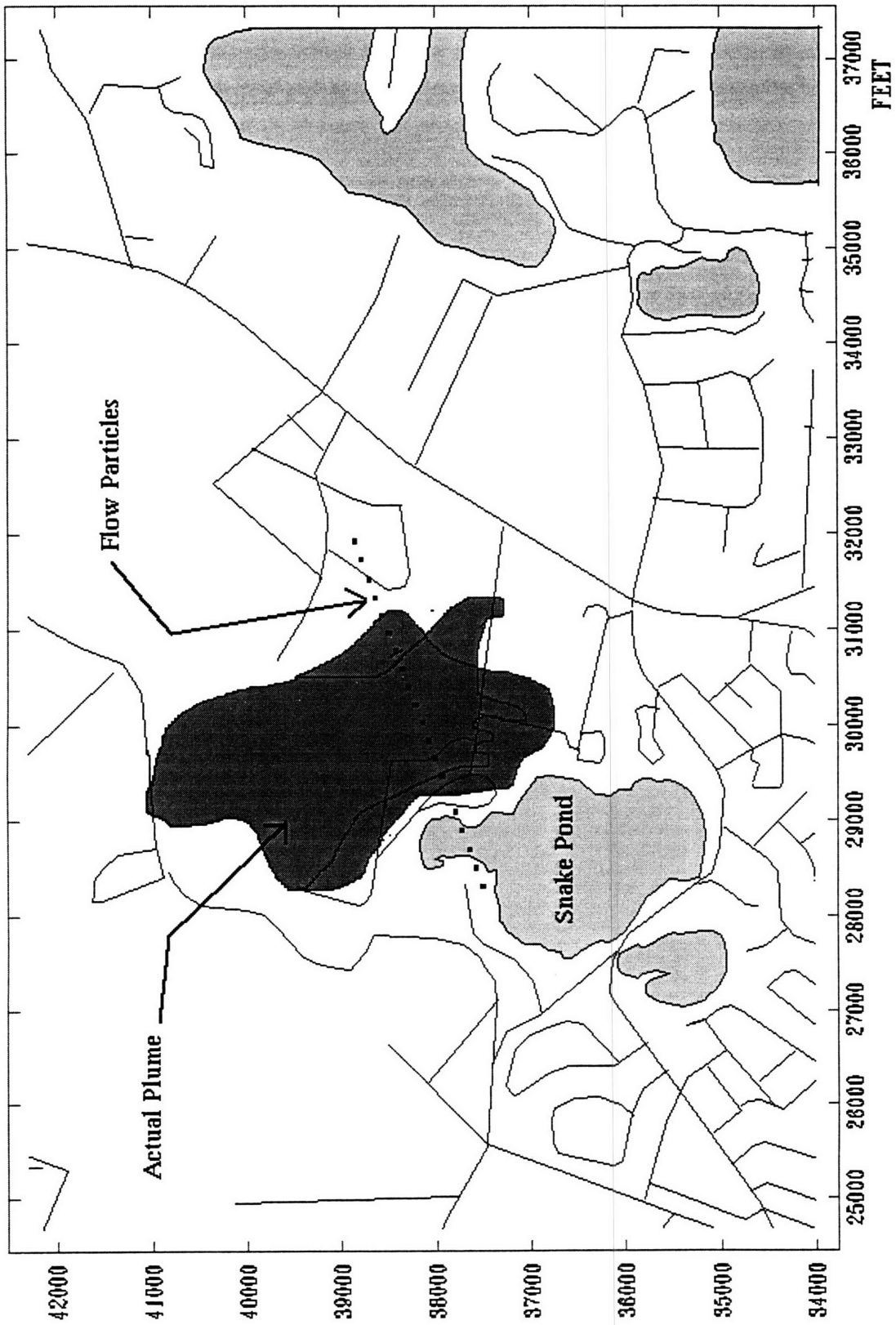

FIGURE 9 - Extent of Actual Plume, and Flow Particles Locations.

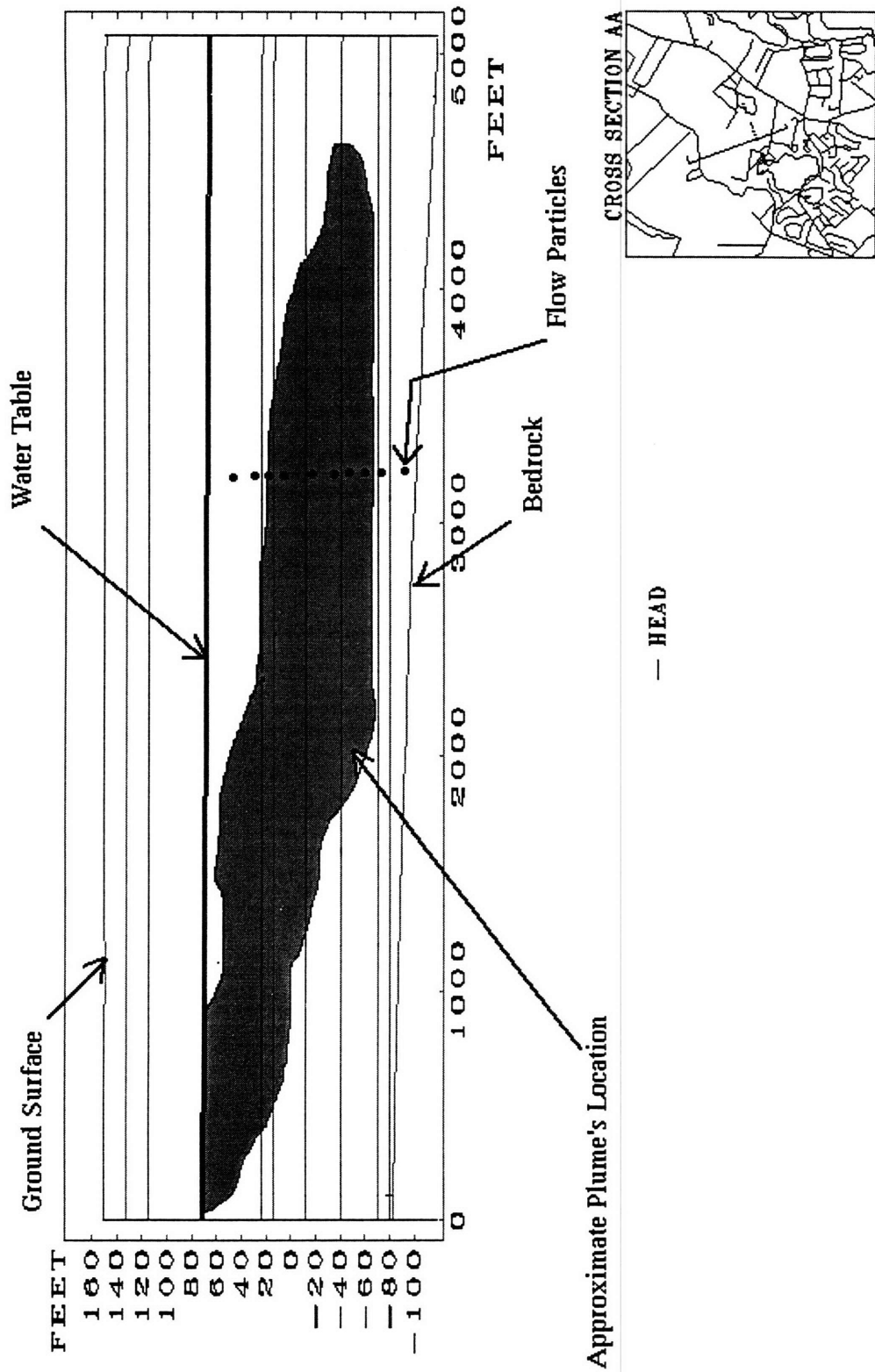

FIGURE 10.A - Longitudinal Cross Section of Plume's Extent and Flow Particles Locations.

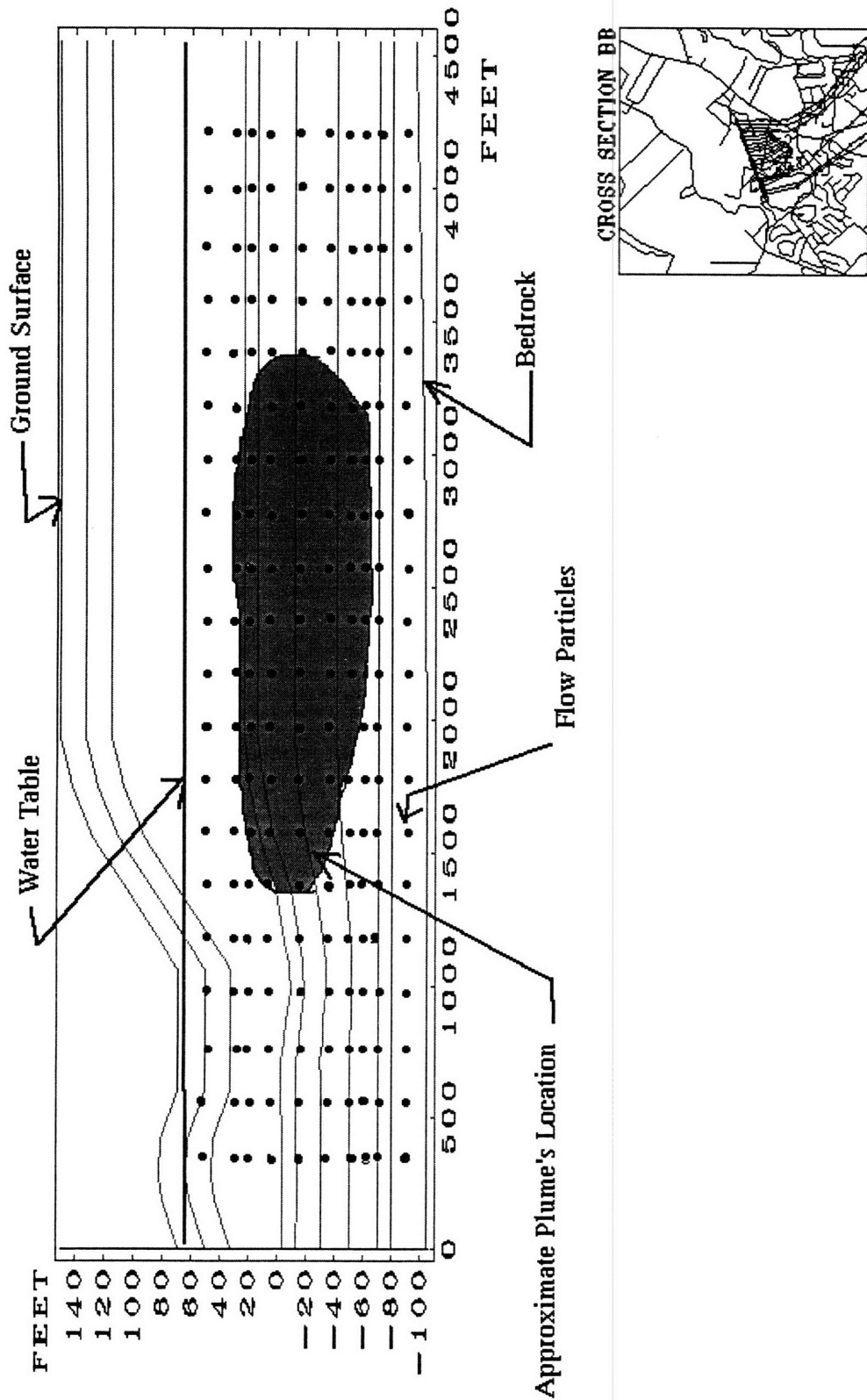

FIGURE 10.B - Cross Section of Plume's Extent and of Flow Particles Locations.

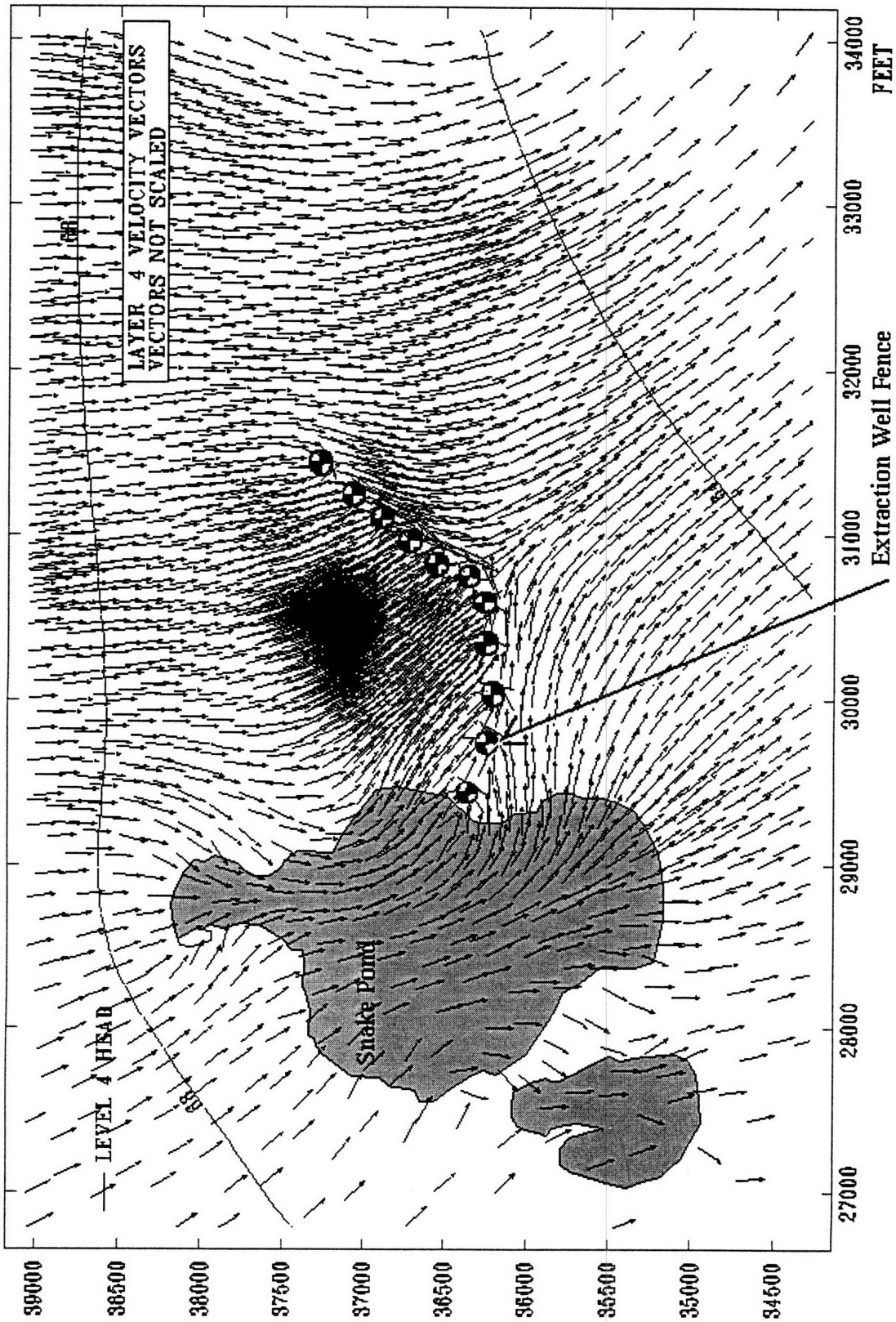

FIGURE 11 - Groundwater Flow Velocity Vectors, and Extraction Well Fence.

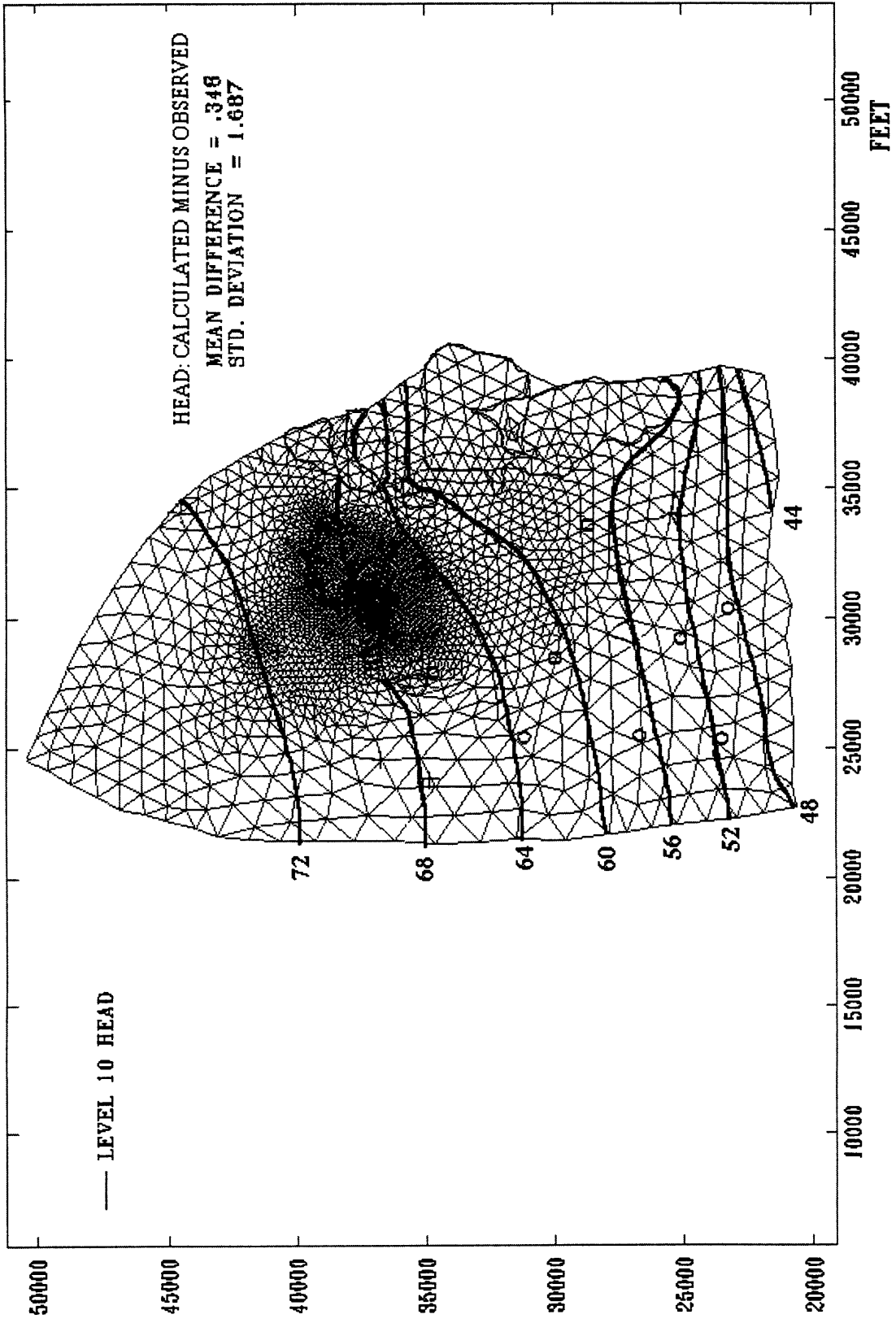

FIGURE 12 - Flow Field with Contours of Constant Head Showing.



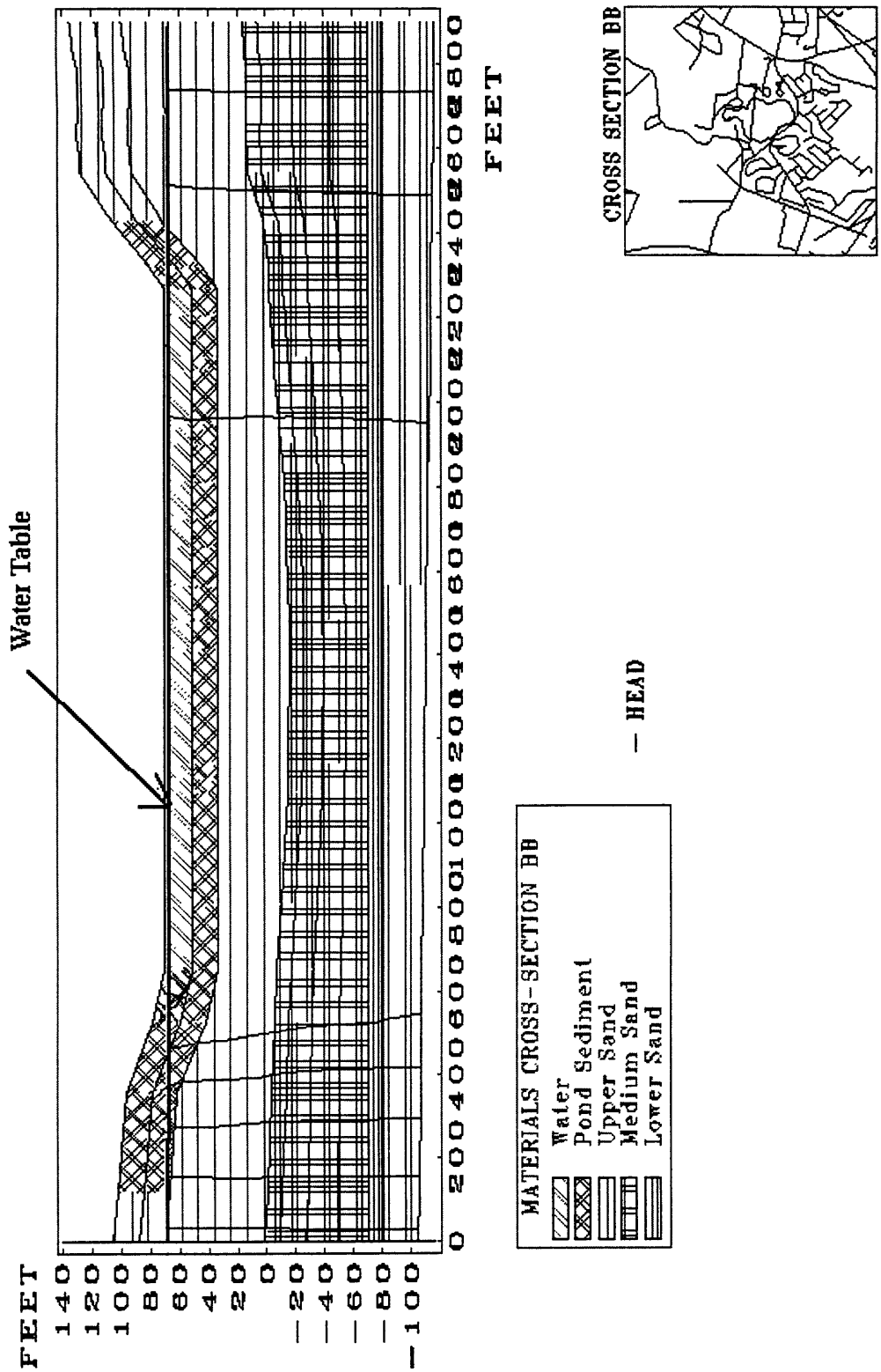

FIGURE 13 - Water Table Elevations Through Snake Pond.

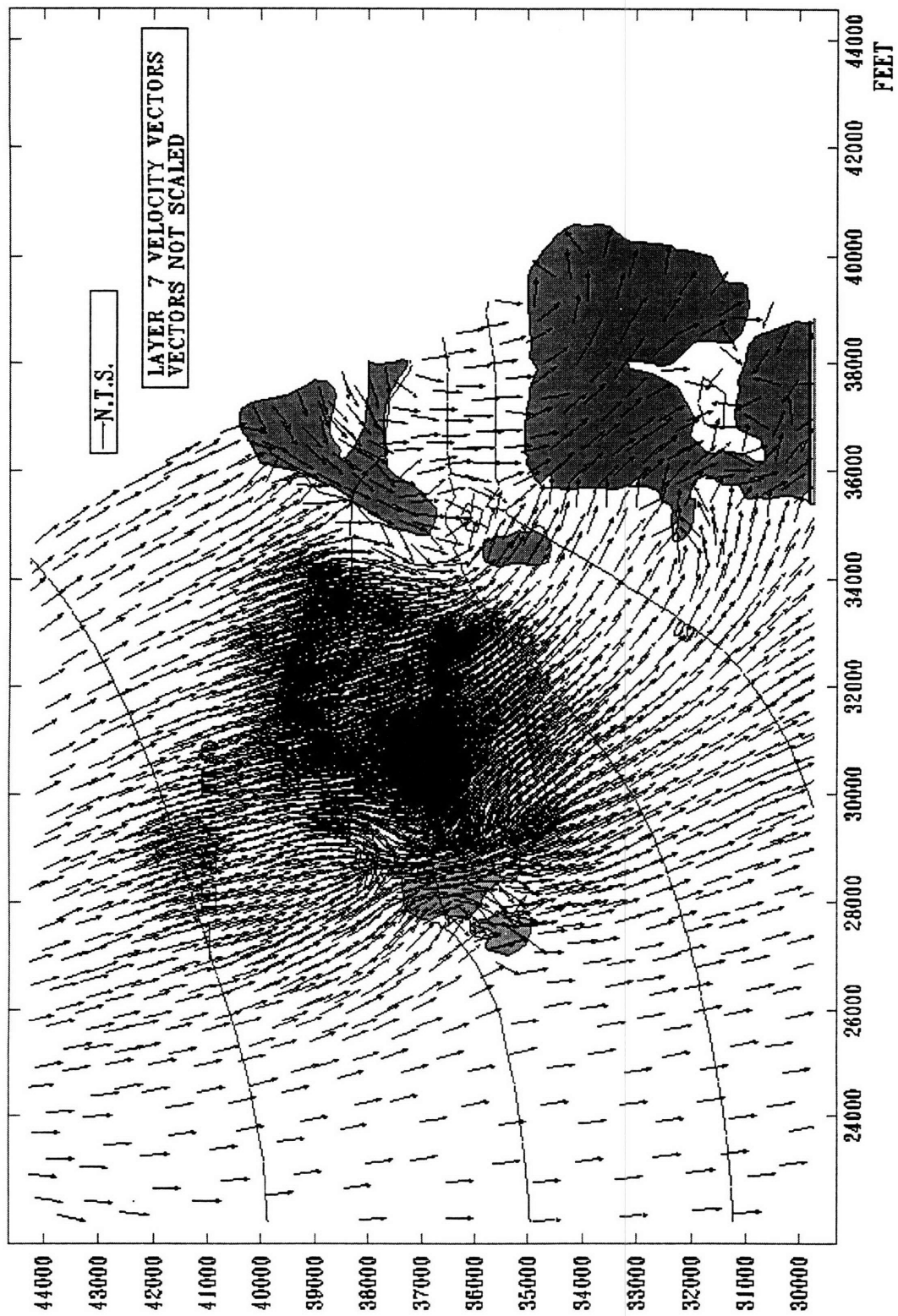
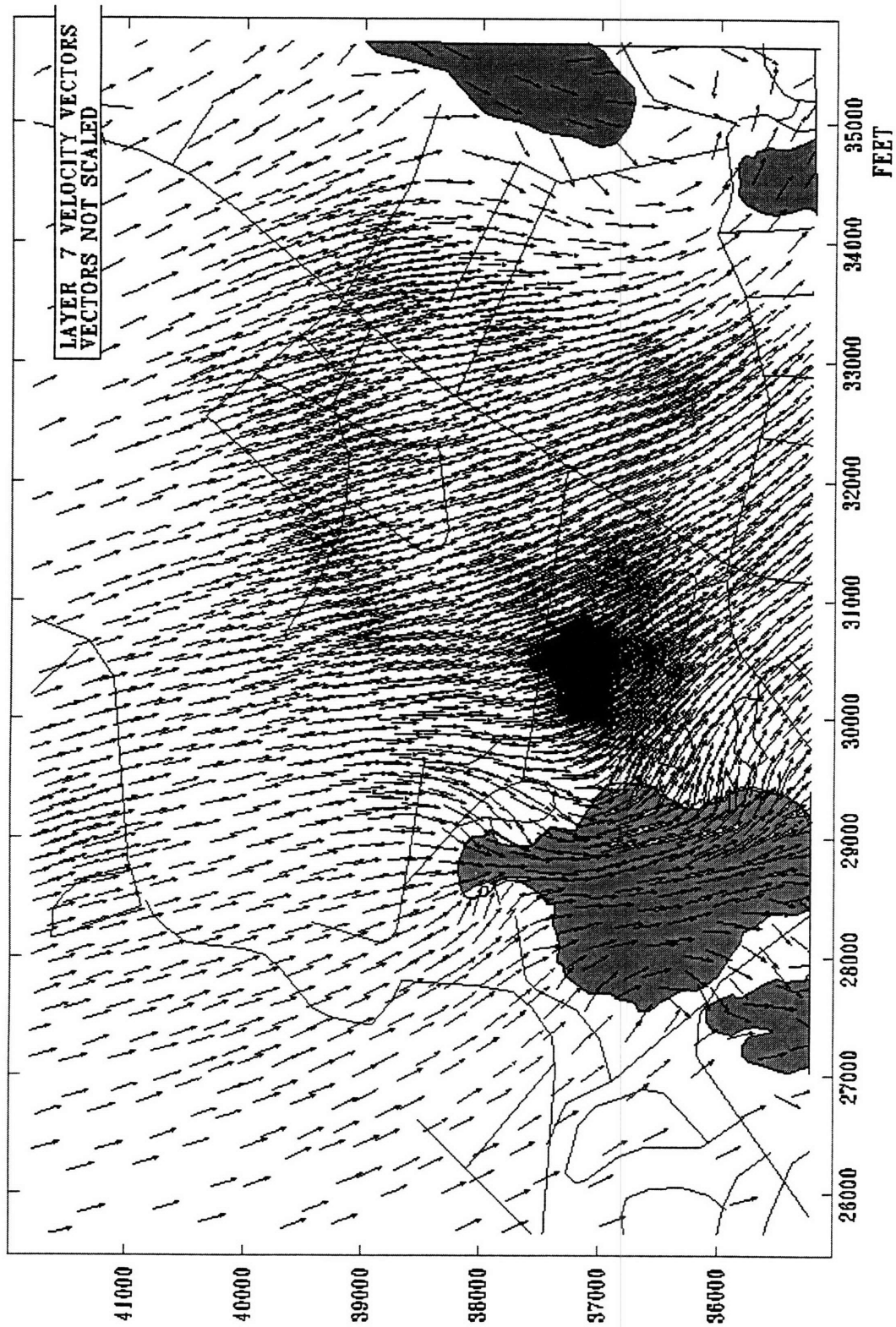

FIGURE 14.A - Groundwater Flow Velocity Vectors Showing the Principal Direction of Flow Under Natural Conditions.



**FIGURE 14.B** - Groundwater Flow Velocity Vectors Showing the Direction of Flow at the Spill Location Under Natural Conditions.



FIGURE 15 - Plan View of Simulated Migration for Benzene Plume.

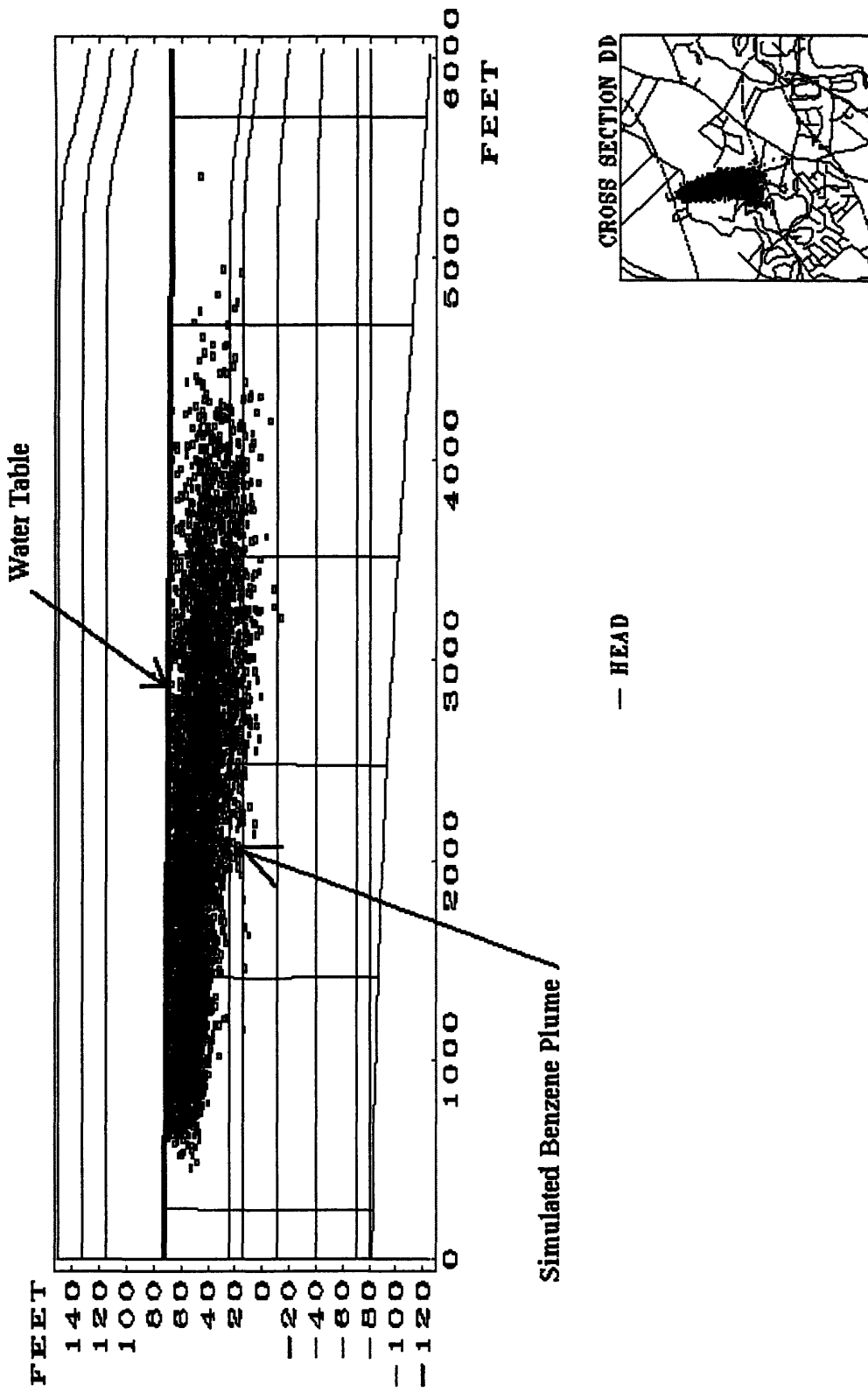

FIGURE 16 - Longitudinal Cross Section of Simulated Migration for Benzene Plume.

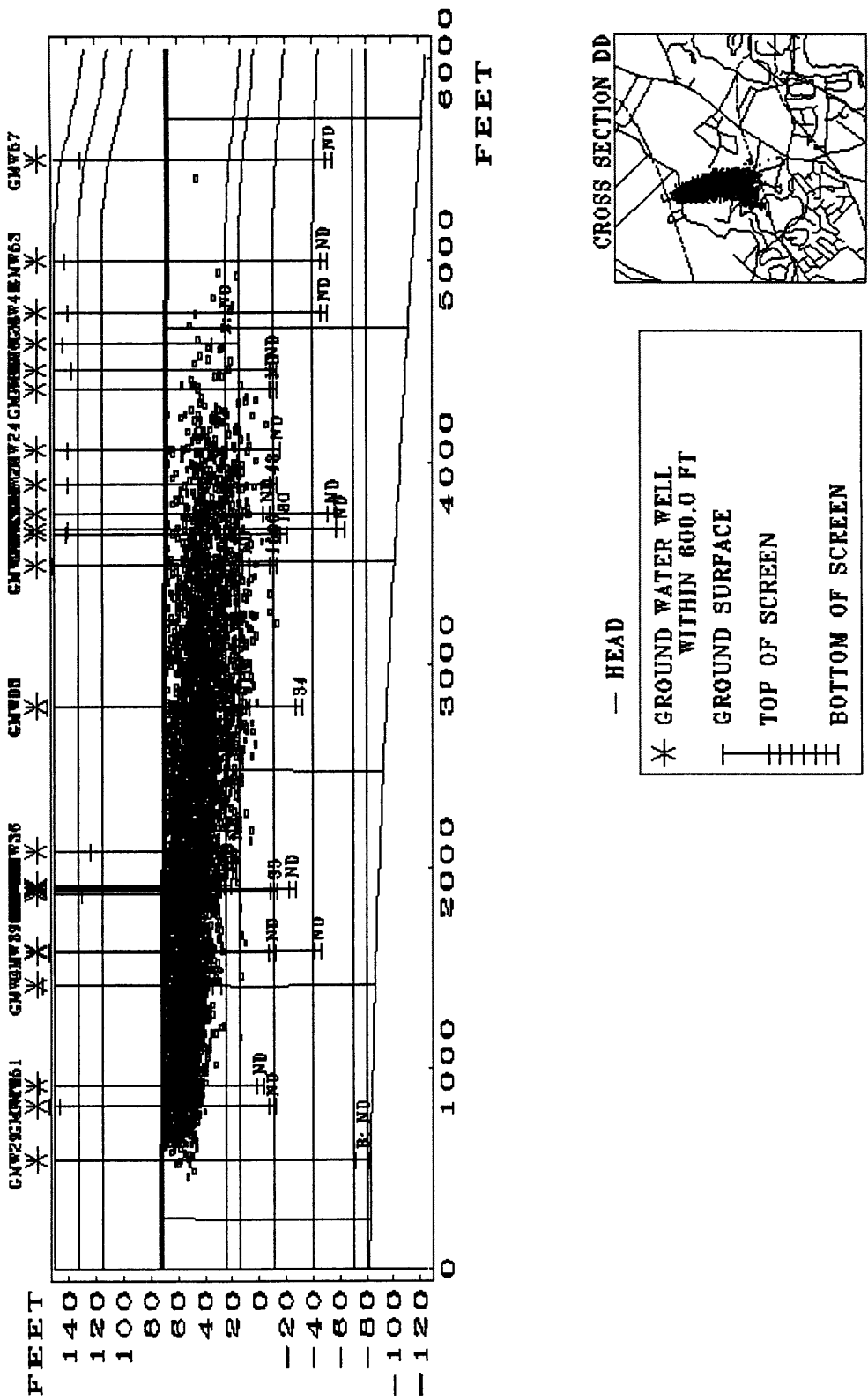

FIGURE 17 - Simulated Plume and Observed Concentrations of Benzene.

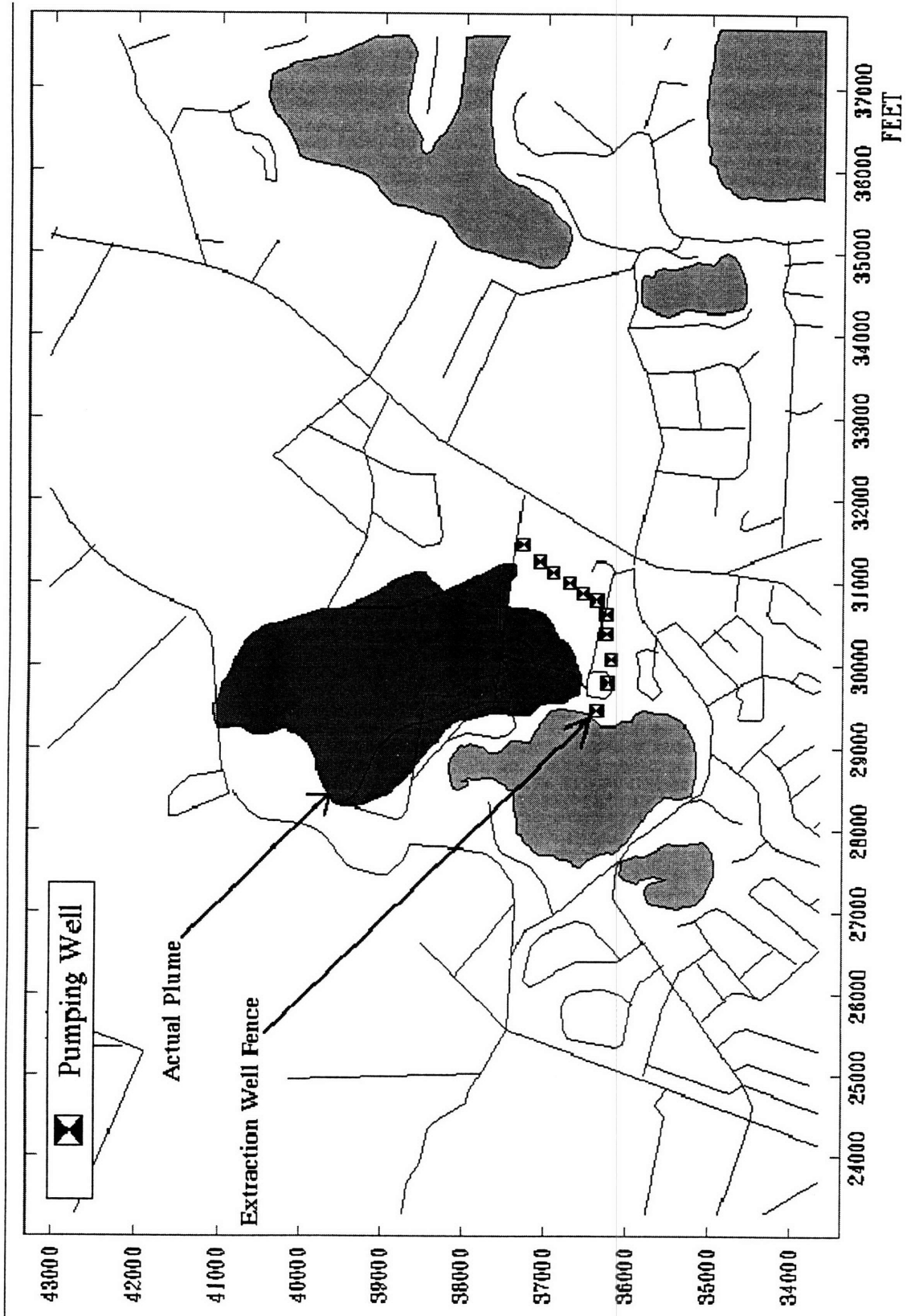
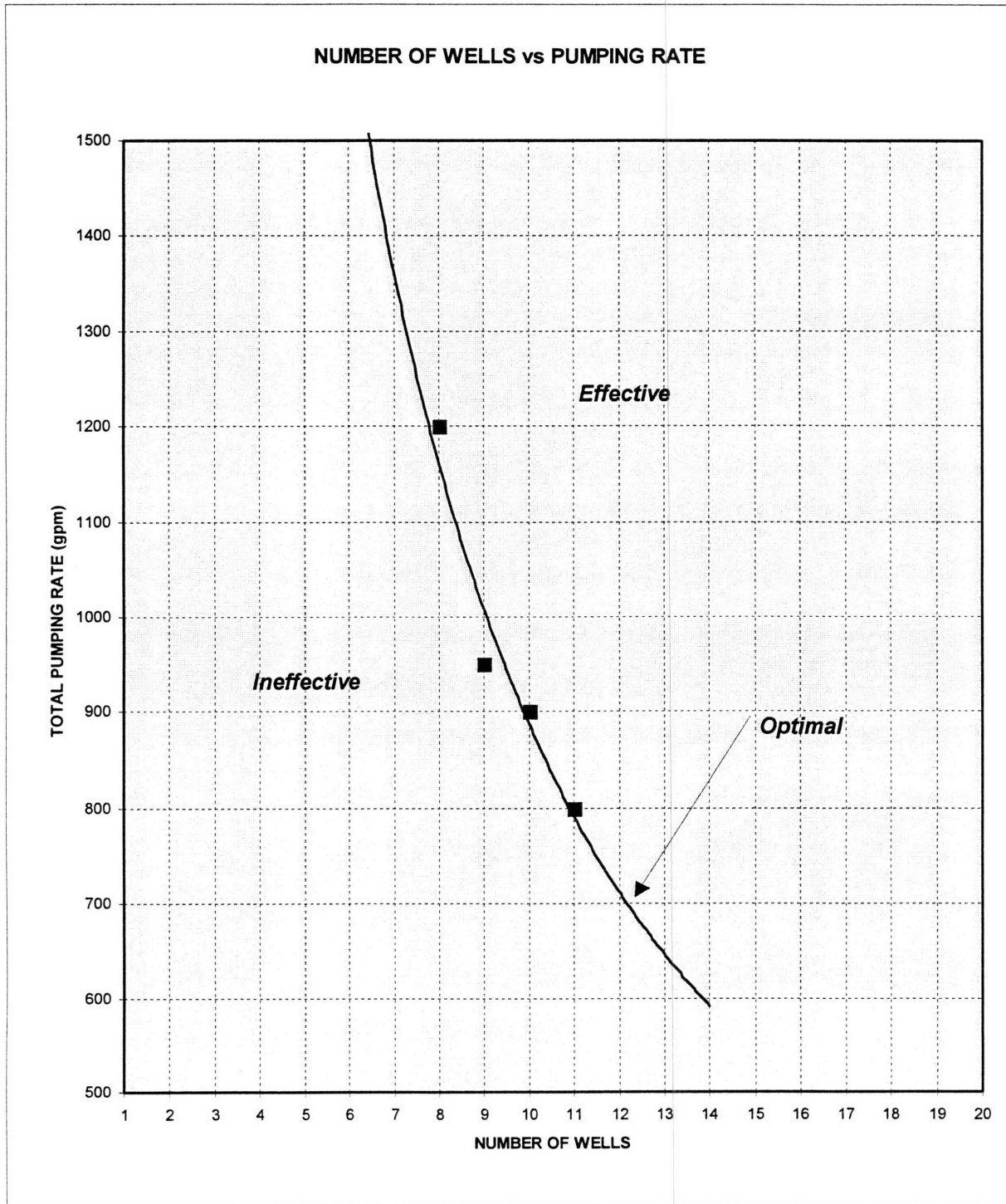
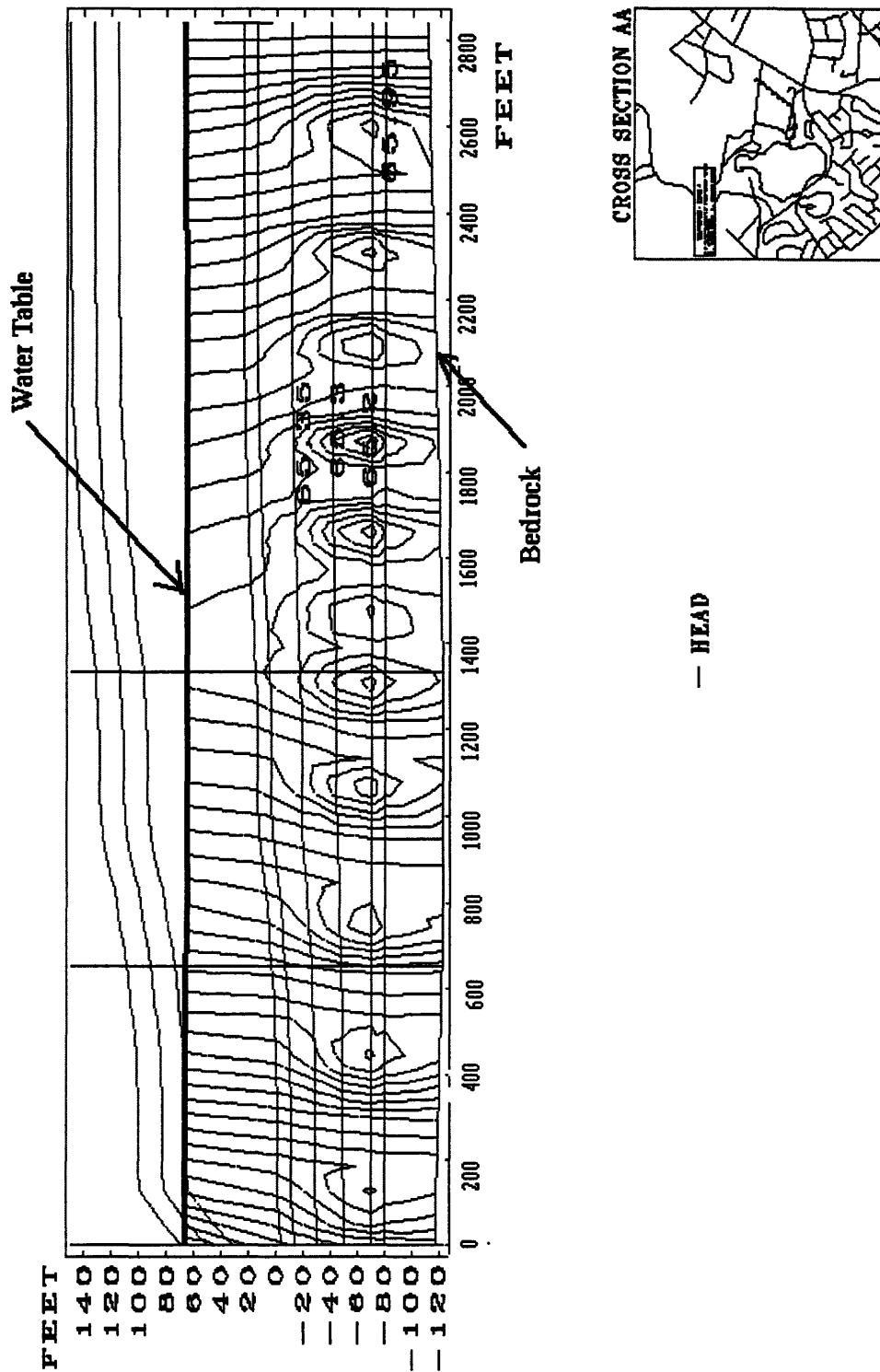

FIGURE 18 - Extraction Well Fence Location and Observed Contaminated Plume.

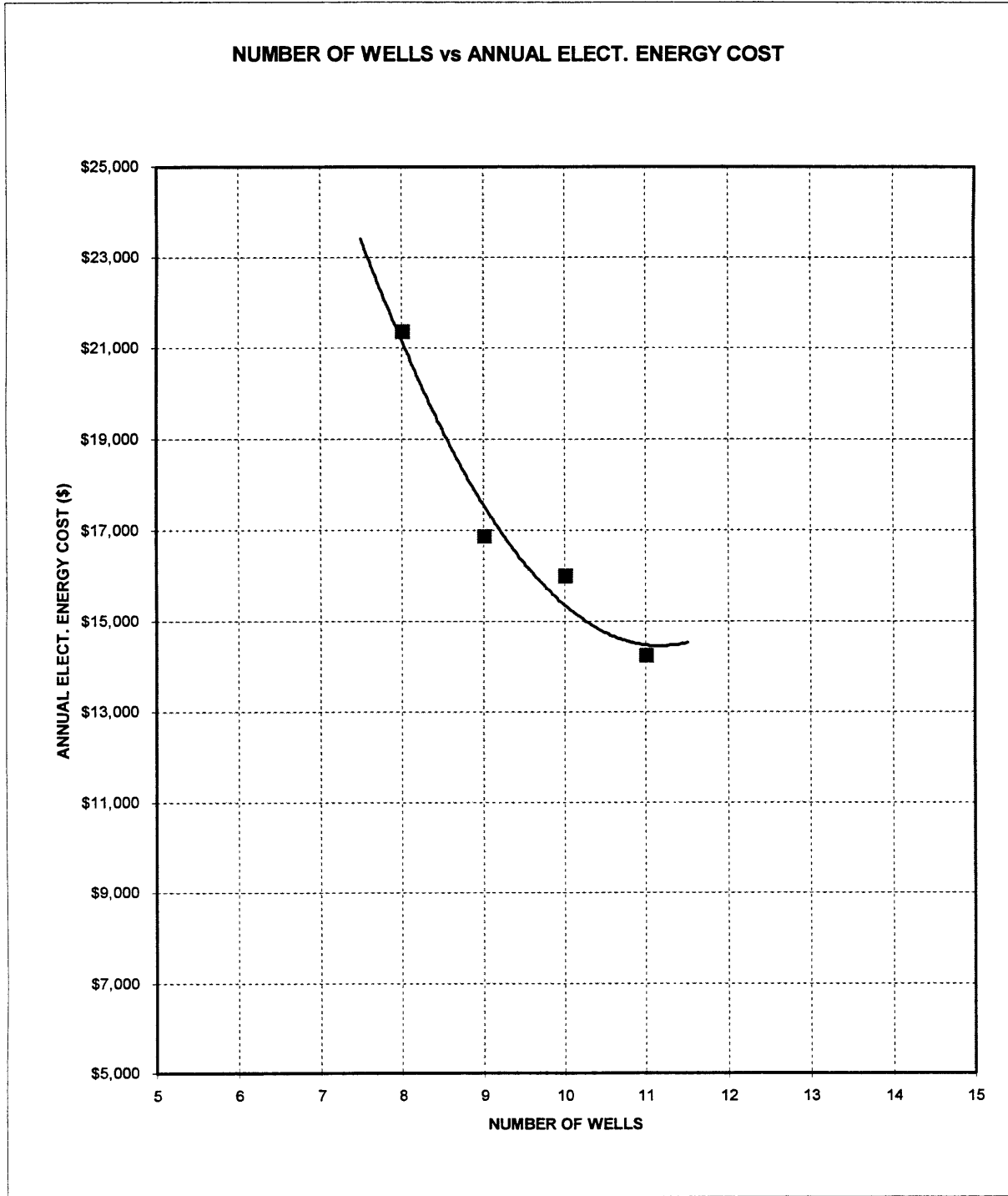

**FIGURE 19** - Plot of Number of Wells versus the Respective Pumping Rates.

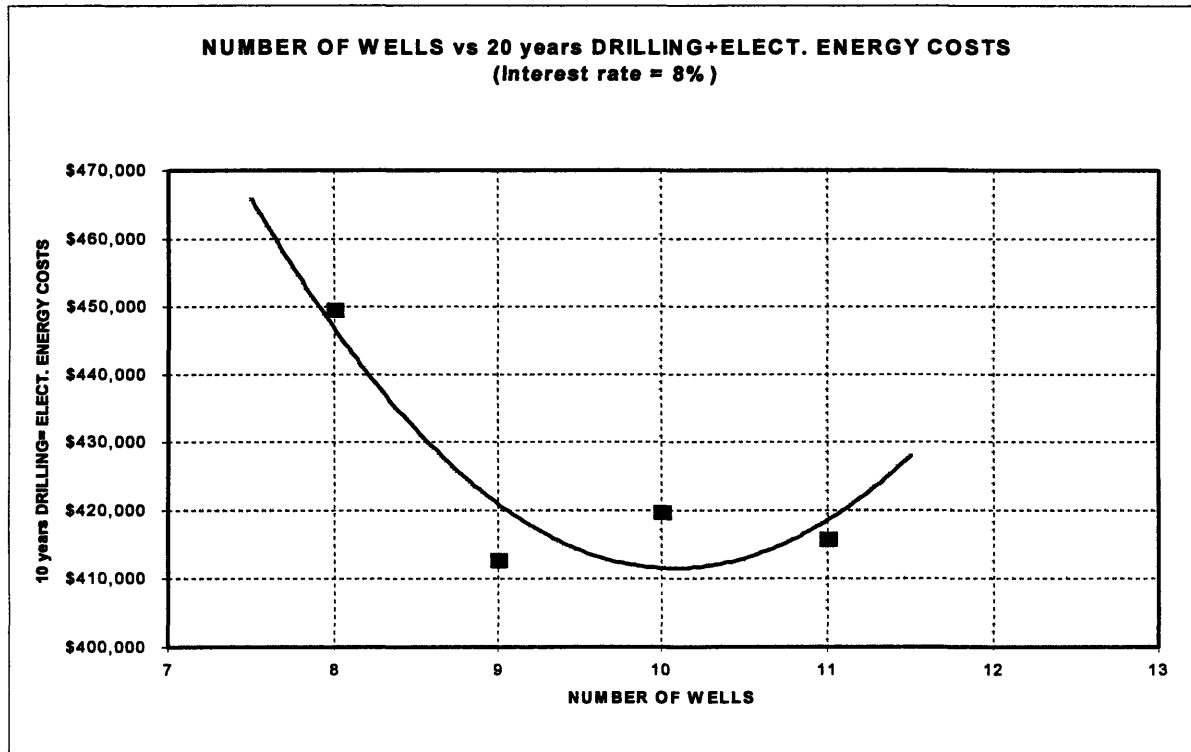



**FIGURE 20 - Vertical Cross Section of the Extraction Well Fence Showing the Wells' Influence on the Head Values.**



**FIGURE 21** - Plot of Cost Analysis: Number of Wells versus Annual Operating Costs.



**FIGURE 22.A** - Plot of Cost Analysis: Number of Wells versus Total Costs for 20 Years.

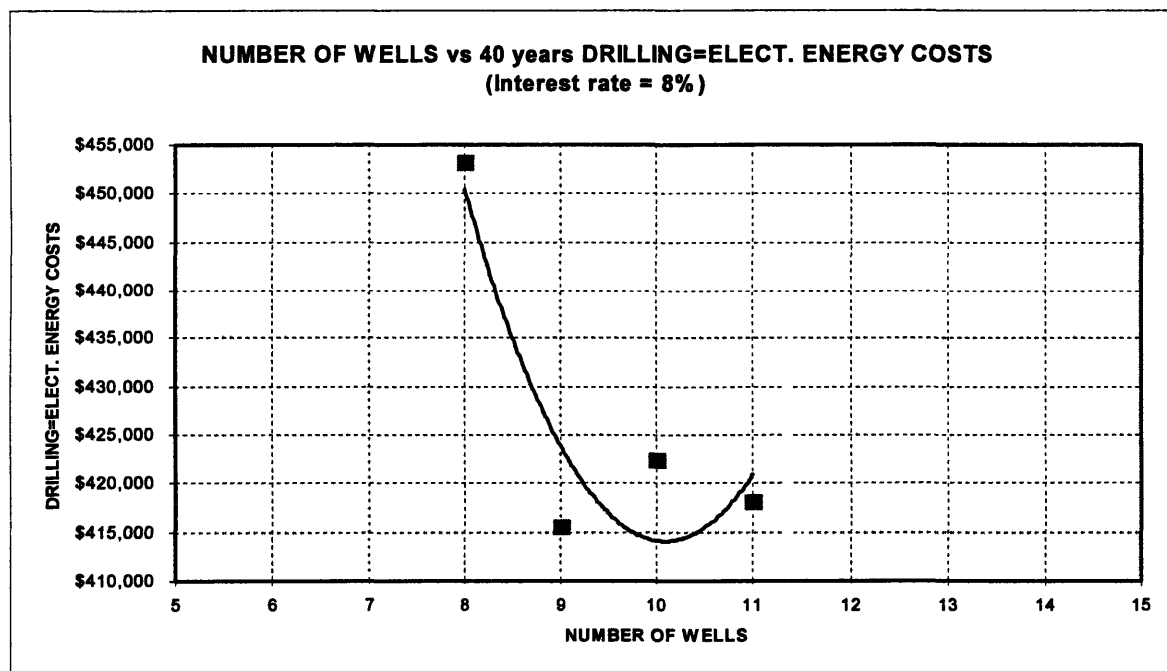

**FIGURE 22.B** - Plot of Cost Analysis: Number of Wells versus Total Costs for 40 Years.

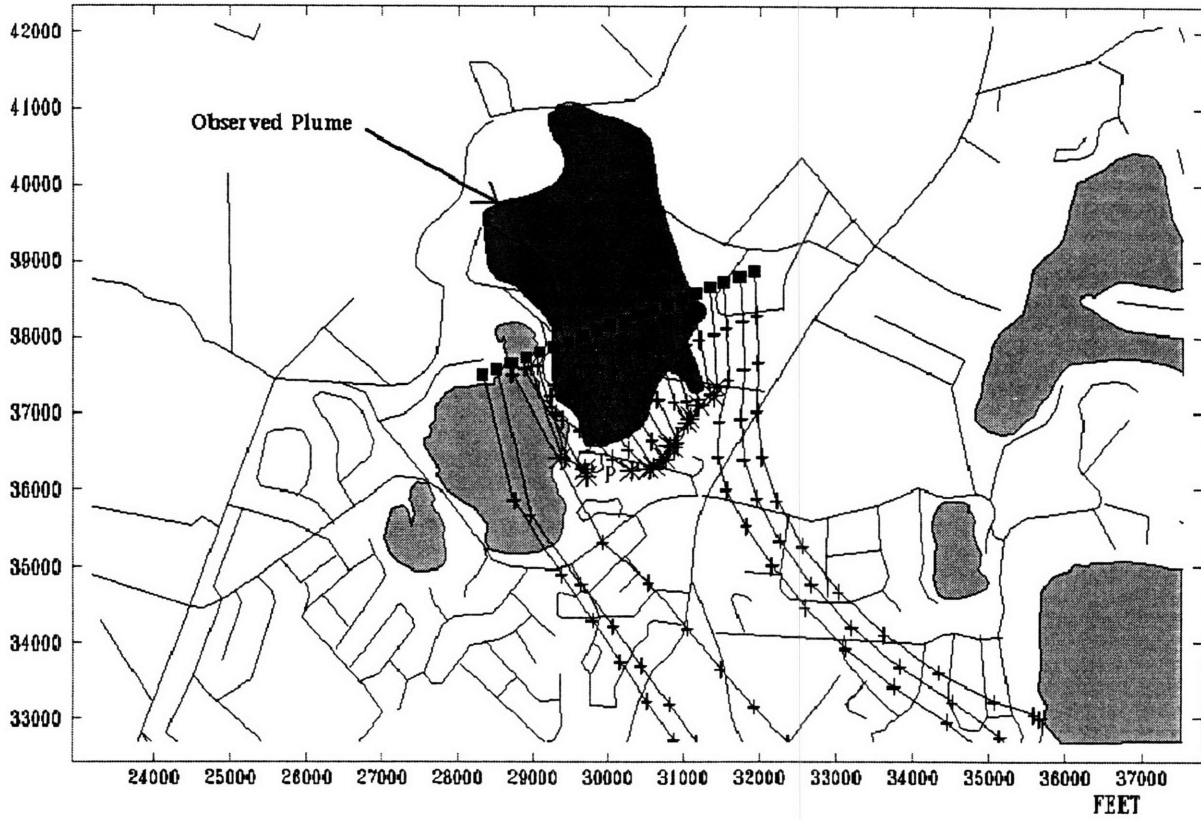

FIGURE 23.A - Plan View of Extraction Well Fence Capture of Flow Particles.

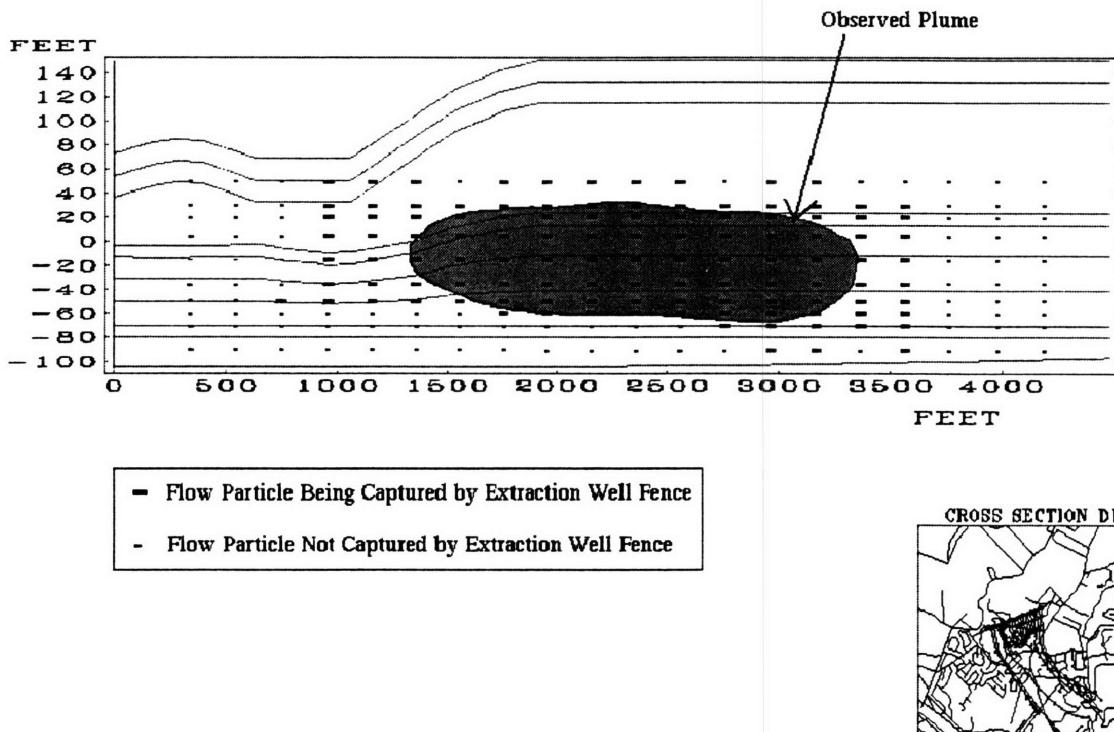

FIGURE 23.B - Cross Sectional View of Extraction Well Fence Capture of Flow Particles.

## 9. REFERENCES

- Domenico, P. A., and F. W. Schwartz, *Physical and Chemical Hydrogeology*, John Wiley & Sons, Inc., New York, 1990.
- Freeze, R. A., and J. A. Cherry, *Groundwater*, Prentice Hall, Inc., New Jersey, 1979.
- LeBlanc, D. R., J. H. Guswa, M. H. Frimpter, M. H. Londquist, Ground-Water Resources of Cape Cod, Massachusetts, *Department of the Interior, U.S. Geological Survey Hydrologic Investigations, Atlas HA-692 (sheet 3 of 4)*, 1986
- Savoie, J., Altitude and Configuration of the Water Table, Western Cape Cod Aquifer, Massachusetts, March 1993, *U.S. Department of the Interior, U.S. Geological Survey, Open-File Report 94-462*, 1995.
- Gelhar, L. W., C. Welty, K. R. Rehfeldt, A Critical Review of Data on Field-Scale Dispersion in Aquifers, *Water Resources Research.*, 28(7), 1955-1974, July 1992.
- Hutchings, T., Application of Modeling Techniques to Test Hypotheses Concerning the Migration of Aviation Gasoline from a Surface Spill, M.S. Thesis, Dept. Of Civil and Environmental Engineering, Massachusetts Institute of Technology, 1995.
- Schwarzenbach, R. P., P. M. Gschwend, D. M. Imboden, *Environmental Organic Chemistry*, John Wiley & Sons, New York, 1993.
- Oldale, R. N., *Seismic Investigations on Cape Cod, Martha's Vineyard, and Nantucket, Massachusetts, and a Topographic Map of the Basement Surface from Cape Cod Bay to the Islands*, U.S. Geological Survey Prof. Paper 650-B, B122-B127, 1969.
- Masterson, J. P., and P. M. Barlow, *Effects of Simulated Ground-Water Pumping and Recharge on Ground-Water Flow in cape Cod, Martha's Vineyard, and Nantucket Island Basins, Massachusetts*. U.S. Geological Survey, Open-File Report 94-316, 1994
- MacKay, D., W. Y. Shiu, K. C. Ma, *Illustrated Handbook of Physical/Chemical Properties and Environmental Fate for Organic Chemicals, vol. I, Monoaromatic Hydrocarbons, Chlorobenzenes and PCB's*, Lewis Publishers, 1992.
- Camp, Dresser & McKee, Inc., *Dynsystem, Groundwater Flow And Transport Modeling System, Reference Guide*, 1992.
- Camp, Dresser & McKee, Inc., *Dynflow, A 3-Dimensional Finite Element Groundwater Flow Model, Description and User's Manual, Version 3.0*, 1984.
- Camp, Dresser & McKee, Inc., *Dyntrack, A 3-Dimensional Transport Model for Groundwater Studies, Description and User's Manual, Version 1.0*, 1984.

Advanced Sciences, Inc., *Remedial Investigation Report, Remedial Investigation/Feasibility Study, FS-12 Study Area*, Installation Restoration Program, Massachusetts Military Reservation, prepared for HAZWRAP, Oak Ridge, Tennessee, December 1993.

HydroGeoLogic, Inc., *Aquifer Test Analysis, Massachusetts Military Reservation, Cape Cod, Massachusetts*, Hazardous Waste Remedial Action Program, Oak Ridge, Tennessee, June 1994.

Triantopoulos, D., *Modeling of a Jet Fuel Spill in the Groundwater at the Massachusetts Military Reservation*. M.Eng. Thesis. Massachusetts Institute of Technology, 1996.

U.S. Geological Survey, Department of the Interior, *Cotuit Quadrangle, Massachusetts, N4132.5-W7022.5/7.5*. 1974.

## 10. APPENDIX

**An Assessment of Water Supply Issues and  
Current and Alternative Remedial Schemes for  
Fuel Contaminated Groundwater**

*Including a Case Study:  
Fuel Spill 12 at the Massachusetts Military Reservation*

**VOLUME I - Group Report**

Christophe Bösch  
Judy Gagnon  
Holly Goo  
Karen Jones  
Vanessa Riva  
Mitsos Triantopoulos

Department of Civil and Environmental Engineering  
Massachusetts Institute of Technology

May 20, 1996



## EXECUTIVE SUMMARY

The Massachusetts Military Reservation (MMR) is a Superfund site located in Cape Cod, Massachusetts. Groundwater has been contaminated by years of military activity at the MMR. A number of plumes, or discrete zones of contamination, emanate from the reservation. A plan to control the sources and contain the leading edges of these plumes is currently under design. One plume in particular, Fuel Spill 12 (FS-12), is the result of a fuel pipeline break. This leaked approximately 70,000 gallons of JP-4 fuel into the subsurface, and ultimately the aquifer. The resulting contamination includes benzene, a fuel component, and ethylene dibromide (EDB), a fuel additive. Both are known carcinogens. The contamination of groundwater by this plume, as well as others, has affected the local water supplies, initiating the closure of municipal and private wells.

This project focuses on FS-12 as a case study to assess the movement and treatment of fuel-contaminated groundwater plumes. In addition, water supply issues related to regional groundwater contamination are investigated. These issues include an assessment of alternatives to replace lost water supplies and the role of public perception in selecting these. Finally, the previous remediation decisions at the MMR and FS-12 are analyzed from an economic standpoint.

### Fuel Spill 12 - Model Results

The natural groundwater flow is simulated using a finite element model. The movement of contaminants is tracked on a local scale. The effects on Snake Pond, a water body close to the source of the plume, are also assessed. The model shows that the contamination effects on Snake Pond are negligible under a worst case scenario simulation.

### Fuel Spill 12 - Treatment Alternatives

Four treatment techniques for fuel-contaminated groundwater are assessed: (1) natural attenuation i.e. “do nothing” alternative, (2) air sparging & soil vapor extraction, (3) extraction well fence, and (4) reactive wall.

- Natural restoration of the FS-12 site could be an attractive clean-up strategy given the high costs associated with active remediation of contaminants. Provided conditions are favorable, the dissolved plumes of benzene and ethylene dibromide are expected to degrade rapidly. Concentration levels below the maximum contaminant levels (MCLs) could be attained before the plume discharges into nearby surface waters. However, there is a lack of information needed to quantitatively assess the consequences of this strategy.
- Air sparging & soil vapor extraction are currently being implemented at FS-12 to control the source of contamination. The estimated time to remediate the source is two years, though modeling results from this study indicate that a much longer remediation time will be necessary to attain MCLs. This estimation was attained through the use of a spreadsheet model that calculates relative volatilization rates for each chemical constituent of JP-4 fuel. This study estimates a remediation time of more than 9 years to reach MCLs of 5 ppb in the groundwater near the source--over four times higher than the MMR's estimate. Both estimates rely primarily on the 'liquid to vapor phase' mass transfer mechanism.
- An extraction well "fence" is currently being designed to contain the leading edge of the FS-12 plume. A fence is a row of pumping wells designed to capture the plume as it migrates downgradient. Using the finite element model for this case study, a fence was designed. The design calls for 11 pumps operating at 800 gallons per minute (gpm) to capture the plume.
- The permeable reactive wall is assessed for its potential application at the FS-12 site. As the contaminated groundwater passes through the wall, the reactive media degrades the contaminants. After passage through the wall, clean water exits from the other side. Although the wall can degrade EDB, it cannot readily degrade benzene. Based on field observations, the plume is too deep within the ground for the wall to be implemented.

#### Massachusetts Military Reservation - Water Supply Issues

- One objective of the plume containment scheme is to protect the Upper Cape water resources. However, only a small fraction will be preserved by the proposed plan. In addition, the scheme does not address the major constraint on future water

supply expansion-the lack of access to land to drill new wells. In this respect, there is a clear need to protect groundwater resources by establishing zones of groundwater protection, and land acquisition near wellfields.

- Due to the abundance of water resources in the Upper Cape area, groundwater contamination is not expected to cause water shortages in the area for the next 25 years, and probably not beyond. The exception is the town of Falmouth where alternative water supplies such as treated groundwater are needed.
- The public perception of drinking treated groundwater is assessed by interviewing local environmental groups, involved citizens, and local water district superintendents. The public is unwilling to drink treated groundwater for four reasons: (1) they believe their current water supply is pristine; (2) they believe the carbon treatment system cannot remove contaminants to a non-detect level; (3) they do not fully trust the MMR's statements about the cleanliness of the treated water; and (4) they would prefer that new wells be drilled to find clean sources of water instead of treating water from existing wells.

#### Massachusetts Military Reservation - Cost-Benefit Analysis

Current plume containment plans are estimated to cost \$250 million. A cost-benefit analysis was completed to compare this expense to other alternatives. A review of costs and benefits of the plume containment program disproves the following myths:

- *The plume containment plan will address public health and environmental hazards.*  
The threat to public health has already been partially addressed by alternative water supply. Therefore, risks could be essentially eliminated for an additional investment of less than \$10 million.
- *The plume containment plan will protect property value.*  
In the worst case scenario, the total devaluation of property would amount to less than \$20 million. This does not justify the \$250 million containment costs.
- *The plume containment scheme will preserve valuable water resources.*  
The water resource benefits associated with preservation of groundwater for future generations are expected to be small. Only a minor fraction of the Upper Cape water resources will be preserved.

Based on the above analysis, the plume containment plan is not justified. However, the hidden objectives of the plume containment scheme appear to be driven by psychological, economic, and political motivations. Tourism and retirement-based income are the main contributors to the Upper Cape's economy. Perception of risk due to unmitigated plumes could significantly impede the Cape's growth, and result in lost revenues amounting to several hundreds of millions of dollars. Thus, assuming growth is a desirable goal, the \$250 million investment could be justified. However one may question whether plume containment would be the most cost-effective means to restore public confidence and reduce the perceived risk.

#### FS-12 - Cost-Benefit Analysis

The high cancer risk and the uncertainties associated with the do nothing alternative would call for the implementation of cleanup measures. Plume containment alternatives, for example the well extraction fence, may be more beneficial than source control alternatives, such as air sparging. This depends on the value placed on the groundwater contaminated by further plume migration.

## **TABLE OF CONTENTS**

<b>1. INTRODUCTION</b>	<b>76</b>
<b>2. STUDY AREA CHARACTERIZATION</b>	<b>79</b>
<b>2.1 The Massachusetts Military Reservation Superfund Site</b>	<b>79</b>
2.1.1 Physical characteristics	79
2.1.1.1 Location	79
2.1.1.2 Topography and Geology	79
2.1.1.3 Geology and Hydrogeology	80
2.1.1.4 Climate	82
2.1.1.5 Ecosystems	82
2.1.2 Socio-Economic Characteristics	82
2.1.2.1 Demographics	82
2.1.2.2 Water Use	83
2.1.2.3 Economy	83
2.1.3 History	83
2.1.3.1 Activity History	83
2.1.3.2 Regulatory History	84
2.1.3.3 Contamination History	84
<b>2.2 The Fuel Spill 12 - A Case Study</b>	<b>86</b>
2.2.1 Physical Site Data	86
2.2.1.1 Geology of FS-12	87
2.2.1.2 Hydrology	88
2.2.2 Site History	88
2.2.3 Extent of Contamination	89
2.2.4 Current Situation	90
<b>3. FINDINGS</b>	<b>91</b>
<b>3.1 Modeling of the Plume</b>	<b>91</b>
3.1.1 Model Description and Development	91

3.1.2 Assessment Of Model Results	97
3.1.2.1 Natural Groundwater Flow	97
3.1.2.2 Contaminant Tracking	97
3.1.3 Surface Water Impacts	101
<b>3.2 Treatment Alternatives</b>	<b>103</b>
3.2.1 No action alternative	103
3.2.1.1 Background Information	103
3.2.1.2 Process Description	104
3.2.1.3 Application at FS-12	105
3.2.2 Source Control - Air Sparging	108
3.2.2.1 Background Information	108
3.2.2.2 Process Description	109
3.2.2.3 Primary Mechanisms and Design Parameters	109
3.2.2.4 System Limitations	112
3.2.2.5 Applications at FS-12	113
3.2.2.6 Alternative Remediation Rate Model	113
3.2.2.7 Time For Contamination To Reach Below MCL	114
3.2.3 Plume Containment	115
3.2.3.1 Pump and Treat - Extraction Well Fence	115
3.2.3.2 Reactive Wall	119
<b>3.3 Water Supply Issues</b>	<b>123</b>
3.3.1 Current Water Situation In The Upper Cape Water Districts	124
3.3.1.1 Water Uses	124
3.3.1.2 Water Resources	124
3.3.1.3 Water Quality	124
3.3.1.4 Future Water Demand In The Upper Cape Water Districts	125
3.3.2 Impact Of Do nothing Alternative On Water Supply	126
3.3.2.1 Alternative Water Supplies	126
3.3.2.2 Investments and Costs Required	127
3.3.3 Impact On Water Supply After Remediation	128
3.3.3.1 Avoided Investments and Costs	128

3.3.3.2 Feasibility of Beneficial Use of Treated Plume Water	129
3.3.4 Public Perception of Drinking Treated Groundwater from MMR	130
<b>3.4 Cost-Benefit Analysis</b>	<b>133</b>
3.4.1 Cost-Benefit Analysis: General Issues and Methodology	134
3.4.2 Cost-Benefit Analysis: The MMR Superfund Site	135
3.4.2.1 Baseline Definition and Remedial Actions Considered	135
3.4.2.2 Identification and Estimation of The Types of Benefits	135
3.4.2.3 Costs versus Benefits	141
3.4.3 Economic Analysis: a Case Study of The Fuel Spill 12	142
3.4.3.1 Cost-Effectiveness Analysis	143
3.4.3.2 Cost-Benefit Analysis	144
<b>4. CONCLUSIONS AND RECOMMENDATIONS</b>	<b>146</b>

## LIST OF FIGURES

FIGURE 1 - LOCATION OF THE MMR	80
FIGURE 2 - HYDROGEOLOGY OF THE MMR	81
FIGURE 3 - PLUME AREA MAP	85
FIGURE 4 - FS-12 AREA MAP	87
FIGURE 5- AREA MAP, AND PLUME LOCATION AND EXTENT OF CONTAMINATION	93
FIGURE 6- GRID AREA	94
FIGURE 7 - CROSS-SECTION SHOWING LAYERS AND MATERIALS	95
FIGURE 8 - WATER TABLE ELEVATIONS (FT)	98
FIGURE 9 - SIMULATED BENZENE PARTICLES	99
FIGURE 10 - CROSS-SECTION ACROSS PLUME	100
FIGURE 11 - CROSS-SECTION ACROSS SNAKE POND SHOWING PARTICLES	102
FIGURE 12 - LONG-TERM CONTAMINANT TRANSPORT	106
FIGURE 13 - COMBINED AIR SPARGING/VACUUM EXTRACTION DIAGRAM	110
FIGURE 14 - AIR SPARGING (SPARGE VAC)	111
FIGURE 15 - EXTRACTION WELL FENCE AND OBSERVED PLUME LOCATION	118

FIGURE 16 - PLAN VIEW OF PARTICLE CAPTURE BY EXTRACTION WELL FENCE	118
FIGURE 17 - CROSS SECTION OF PARTICLES CAPTURED BY THE EXTRACTION WELL FENCE	119
FIGURE 18 - PERMEABLE REACTIVE WALL USED IN CONJUNCTION WITH FUNNELING BARRIERS	120
FIGURE 19 - NO ACTION ALTERNATIVE- NUMBER OF ADDITIONAL CANCERS DEVELOPED OVER THE NEXT 25 YEARS	136
FIGURE 20 - LOSS ON PROPERTY VALUES DUE TO MMR CONTAMINATION (\$ MILLION)	138
FIGURE 21 - PRIMARY BENEFITS ACCRUING OVER 1995-2020 (\$ MILLION, CUMULATIVE)	139
FIGURE 22 - UPPER CAPE ECONOMIC BASE (TOTAL \$610 MILLION, 1992)	140

## LIST OF TABLES

TABLE 1- AQUIFER PROPERTIES	88
TABLE 2- CONTAMINANTS OF CONCERNS: COMPARISON OF AVERAGE AND MAXIMUM CONCENTRATIONS IN THE FS-12 PLUME AGAINST ESTABLISHED MCLS	107
TABLE 3 - AN ASSESSMENT OF WATER REINJECTION/EXTRACTION RATIOS AND WATER COSTS	129
TABLE 4 - IMPACT OF PERCEIVED RISK ON ECONOMIC BASE	140
TABLE 5 - DISCOUNTED COSTS AND BENEFITS FOR THE PERIOD 1995-2020	141
TABLE 6 - DISCOUNTED COSTS FOR THE PERIOD 1995-2020 (INTEREST RATE = 5 %)	143



## 1. Introduction

The Massachusetts Military Reservation (MMR), located in Cape Cod, Massachusetts, has housed numerous branches of the military since 1911. Military activities on the reservation have been extensive, impacting the natural resources of Cape Cod. Because of the significant contamination, the MMR has been included as a Superfund site. The site cleanup is being handled by the Installation Restoration Program (IRP) with offices located on the reservation. The current action to remediate the plumes on the reservation is deemed “interim”; only the source and leading edge of the plumes will be controlled. Remediation of the main portion of the plumes are not included within this plan.

Fuel Spill 12 (FS-12) is one of the plumes emanating from the MMR. It is located in the northeast section of the reservation. This plume is the result of a leak in a pipeline which carried JP-4 fuel to the MMR. It is estimated that 70,000 gallons was spilled. Two contaminants within the fuel which pose health hazards are EDB, a fuel additive, and benzene, a fuel component. These contaminants are known carcinogens. Currently, the FS-12 source is being controlled through air sparging and soil vapor extraction. However, the remainder of the plume continues to migrate off base. The nearby Snake Pond, which is used for recreational purposes, is potentially in the pathway of the plume. However, predictions say the plume will not affect the pond.

This project uses FS-12 as a case study to assess various remediation techniques and their applicability to a fuel-contaminated groundwater site. The project also examines water supply issues for the entire region. Specifically, the objectives are:

- To determine the movement of FS-12 and its potential effects on Snake Pond;
- To compare the “do nothing” alternative to treatment with three types of remediation schemes: extraction well fence, air sparging & soil vapor extraction, and permeable reactive wall technologies;

- To identify the water supply issues surrounding groundwater contamination including alternatives for water supply replacement and the public perception surrounding use of treated groundwater;
- To evaluate the decision to remediate at the MMR through a cost-benefit analysis.

## **2. Study Area Characterization**

This section provides background information on the Massachusetts Military Reservation (MMR), as well as details on Fuel Spill 12 (FS-12). It covers physical and sociological features of the local region.

### ***2.1 The Massachusetts Military Reservation Superfund Site***

#### **2.1.1 Physical Characteristics**

##### ***2.1.1.1 Location***

The MMR is located in western Cape Cod, bordering the townships of Bourne, Falmouth, Mashpee, and Sandwich. The expanse of the MMR includes 22,000 acres located in Barnstable County (Figure 1).

##### ***2.1.1.2 Topography and Geology***

The MMR is located on two distinct types of terrain on the Cape Cod Peninsula. The main Cantonment Area lies on a broad, southward-sloping glacial outwash plain. Elevation in the area ranges from 100 to 140 feet above sea level. To the north and west of the MMR, the terrain becomes hummocky with irregular hills and greater topographic relief, and lies in the southward extent of Wisconsin Age terminal moraines. The highest elevation is 306 feet (Stone & Webster, 1995). The entire site is dotted with numerous kettle holes and depressions forming ponds and lakes.

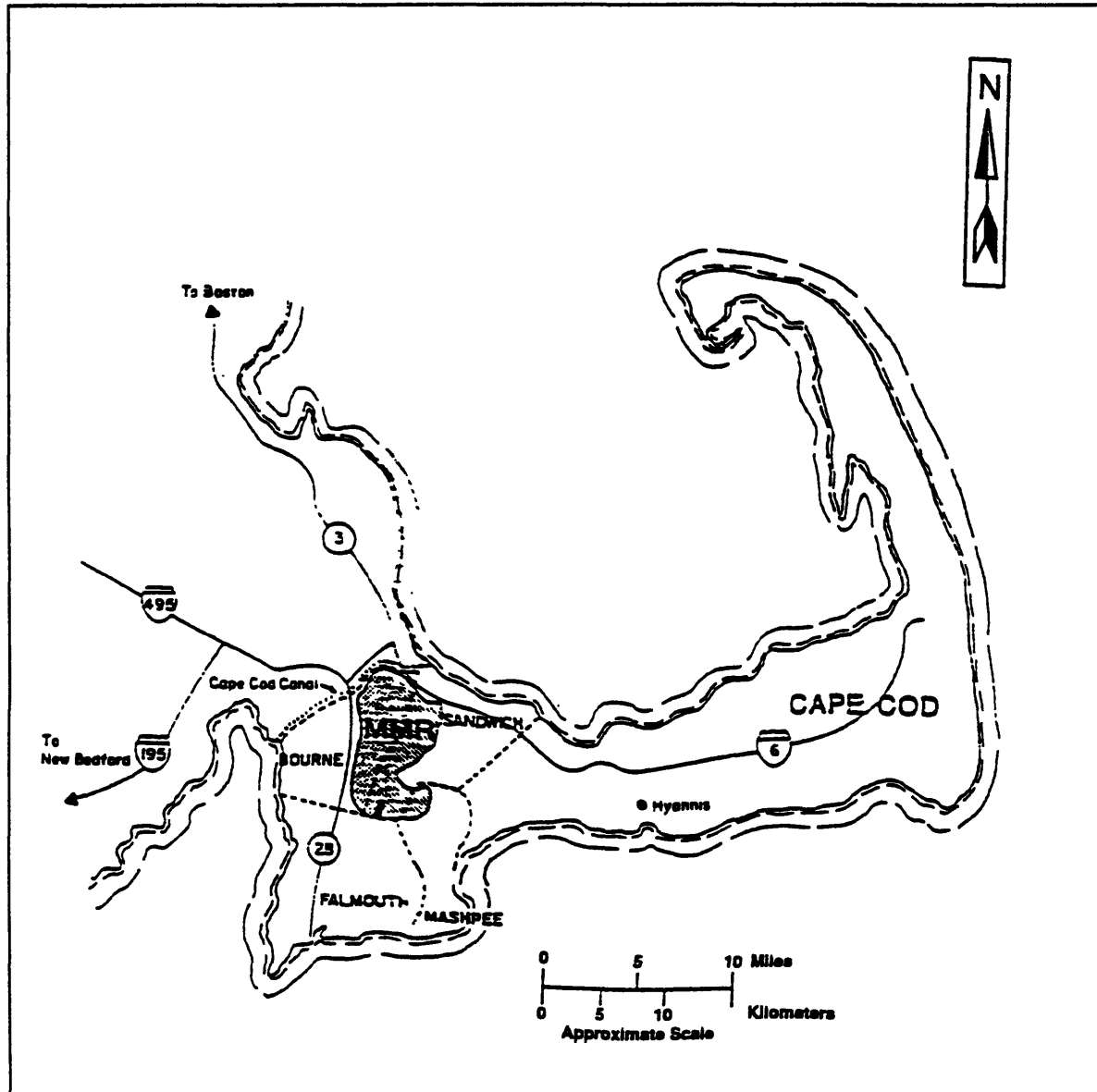

(Stone & Webster, 1995)

Figure 1 - Location of the MMR

### 2.1.1.3 Geology and Hydrogeology

#### Geology

The area is categorized as a glacial outwash plain. Typically, the plain consists of highly permeable sand and gravel, as well as distinctly stratified layers of lower permeability silty sands and clays.

## Hydrogeology

A single groundwater flow system underlies western Cape Cod, including the MMR. The aquifer system is described as unconfined and is recharged by infiltration from precipitation. Accordingly, the aquifer has been characterized by the US Environmental Protection Agency (EPA) as a sole-source aquifer. The high point of the water table is located beneath the northern portion of the MMR (Figure 2). Flow is generally radially outward from this mound. The ocean forms the lateral boundary of the aquifer on three sides.

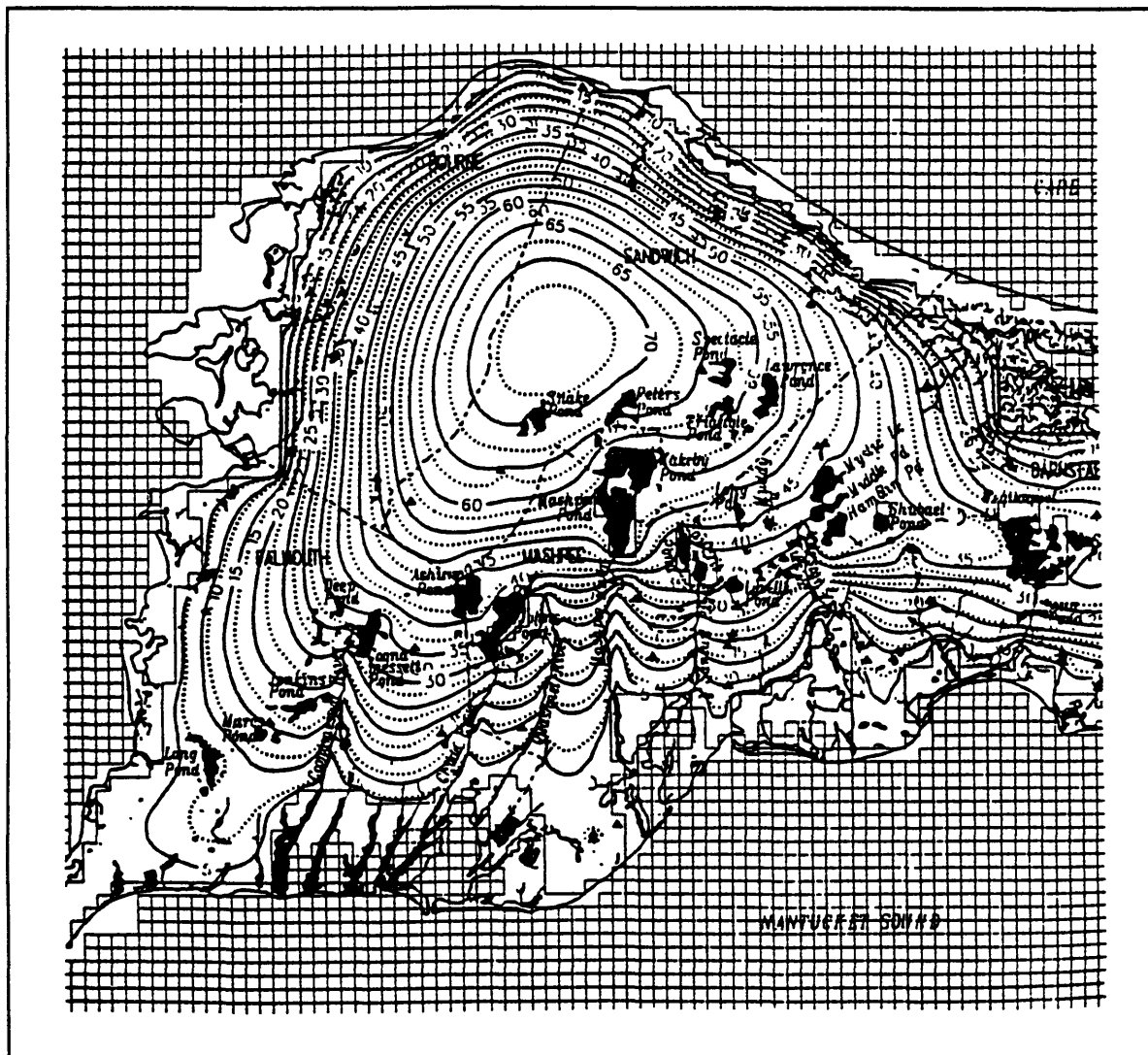

(Department of Environmental Management, 1994)

**Figure 2 - Hydrogeology of the MMR**

#### **2.1.1.4 Climate**

Cape Cod has a temperate climate with precipitation distributed year round. The annual average precipitation is about 47 inches, and annual groundwater recharge is in the range of 0.67 to 0.91 inches/year (Department of Environmental Management, 1994). The highly permeable nature of the sands and gravels underlying the area allow for rapid infiltration of rainfall.

#### **2.1.1.5 Ecosystems**

The Massachusetts Division of Fisheries and Wildlife considers coastal plain ponds as unique, sensitive natural communities in the state. These ponds, found primarily in Cape Cod, occur in glacial kettles lacking surface water inlets. The specialized and rare ecosystem that develops on the shores of these ponds is highly sensitive to water level changes. (Department of Environmental Management, 1994)

### **2.1.2 Socio-Economic Characteristics**

The Upper Cape area comprises of the townships of Falmouth, Sandwich, Mashpee and Bourne. This section discusses demographics, water use, and local economics pertaining to the MMR.

#### **2.1.2.1 Demographics**

The MMR has a year round population of approximately 2,000 people with an additional 800 nonresident employees. Both year round and seasonal residents live in the towns adjacent to the MMR - Falmouth, Mashpee, Sandwich, and Bourne. The population of these towns fluctuate significantly between winter (29,000) and summer (70,000) due to the influx of vacationers. Between 1980 and 1990, the Upper Cape population grew 35%. However Mashpee registered a 113% increase. During the same period, population growth throughout Massachusetts amounted to only 5% (Cape Cod Commission, 1996). Due to the fact that the Upper Cape is sparsely inhabited, the

population directly affected by the plumes is relatively small - 4,000 (current situation) to 6,500 (no action alternative, see Section 3.4.2.2).

### **2.1.2.2 Water Use**

Public water supply customers are the primary water users on Cape Cod, with a base off-season average demand of 8 million gallons per day (mgd) and 16 mgd in-season. In the Upper Cape, 80% of the population is on a central supply system; the remaining 20% of the population relies entirely on individual private wells. For further information regarding water resources, see section 3.3 (Department of Environmental Management, 1994).

### **2.1.2.3 Economy**

The Upper Cape economy was valued at \$600 million in 1992; more than 60% was derived from tourists, seasonal residents, and retirement-based income (see Section 3.4.2.2). Hence, the economic base is believed to be highly sensitive to environmental contamination and associated perceived risk. The Upper Cape's overall valuation of real and personal property increased by 3 times in the past 10 years to \$8 billion in 1994 (Cape Cod Commission, 1996).

## **2.1.3 History**

### **2.1.3.1 Activity History**

Operational units over the MMR's history include the U.S. Air Force, U.S. Navy, U.S. Army, U.S. Marine Corps, U.S. Air National Guard, U.S. Army National Guard, and U.S. Coast Guard. The MMR has housed and served the U.S. military forces since 1911. Within the reservation, military activities included troop training and development, ordinance development, vehicle operation and maintenance, fire fighting, and fuel storage and transport. The MMR was particularly active during World War II (1940-1946). Between 1955-1970, the MMR operated a number of surveillance missions and

aircraft operations through the Air National Guard. Since 1970, the military activities have been scaled down (Advanced Sciences, Inc., 1993).

### ***2.1.3.2 Regulatory History***

On November 21, 1989, the MMR was listed on the National Priorities List as a Superfund site. As a result, the National Guard Bureau (NGB) and the U.S. Coast Guard entered into an Interagency Agreement (IAG) with the EPA in July 1991. As a result, the site investigations and remedial actions are subject to the requirements and regulations of the Comprehensive Environmental Response and Emergency and Liability Act (CERCLA). The Department of Defense (DOD) formulated and organized the Installation Restoration Program (IRP) to address investigations and remediation efforts as a result of hazardous waste sites at DOD facilities (Air National Guard, 1994). Through the Air Force Engineering Services Center, the NGB entered into an IAG with the U.S. Department of Energy (DOE). The NGB, with the support of DOE, analyzed the extent of contamination and potential site contamination at the MMR facility (Air National Guard, 1994).

### ***2.1.3.3 Contamination History***

Past releases of hazardous materials at the MMR have resulted in groundwater contamination in a number of areas. Documented sources of contamination include former motor pools, landfills, fire training areas and drainage structures such as dry wells. Nine major plumes of groundwater contamination (Figure 3) have been found to be migrating from these sources areas and have been defined during extensive groundwater investigations. Seven of the nine plumes have migrated beyond the MMR facility boundary. Extraction and treatment of groundwater have already been initiated for the purpose of containing one plume, the CS-4 plume, to manage the migration of contaminants and prevent further pollution of downgradient areas. The interim action planned by the IRP proposes to extend plume containment schemes to six other plumes. (Stone & Webster, 1995)



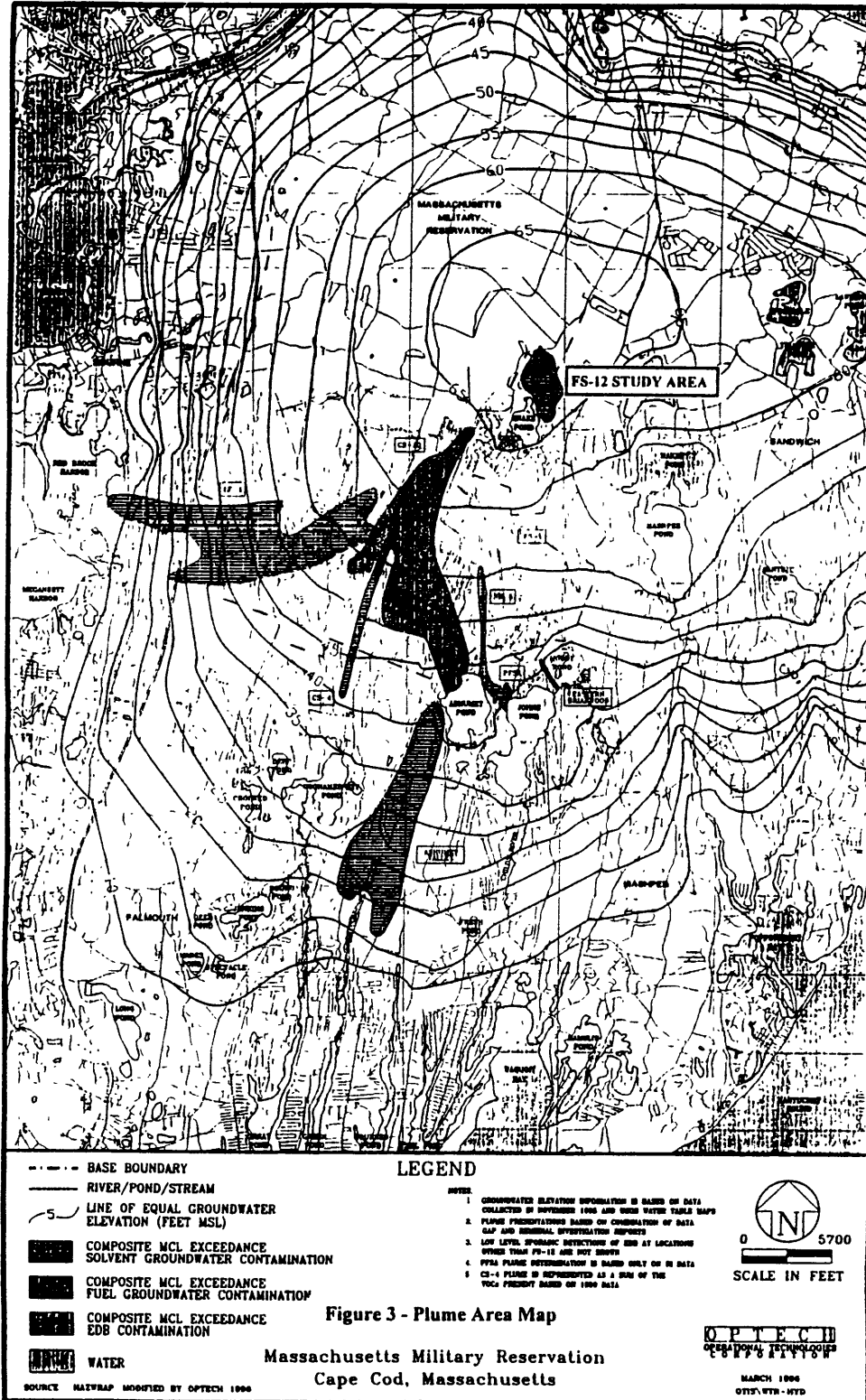

(Operational Technologies Corporation, 1996)

Figure 3 - Plume Area Map

## **2.2 The Fuel Spill 12 - A Case Study**

### **2.2.1 Physical Site Data**

The FS-12 area is located within the Mashpee pitted plain, with a substrata consisting of outwash sands and gravels. The subsurface contains discontinuous lenses of low and high permeability that extend down to 130 feet below the water table. On average, the unconfined Cape Cod aquifer lies 90 feet below ground level. It surfaces at Snake Pond which is located south-southwest of the source. Horizontal groundwater velocities in the area average 0.15 feet/day. This velocity is less than characteristic rates for other plumes on the MMR. This area is located near the crest of the water table mound where the hydraulic gradient is small. Horizontal hydraulic conductivities range from 150 to 400 feet/day.

The topography consists of low relief and rolling hills. Elevations range from approximately 200 feet mean sea level (MSL) to 50 feet MSL. Generally, the north-northwestern portion is characterized by higher relief. Topographical elevation decreases in a southeastern direction. Several water bodies are present in the area surrounding the zone of contamination.

The case study site area, FS-12, is sparsely populated, although a summer camp is located off-base directly south of the source. Most of the contamination flows beneath Camp Good News, as can be seen on (Stone & Webster, 1995)

Figure 4.

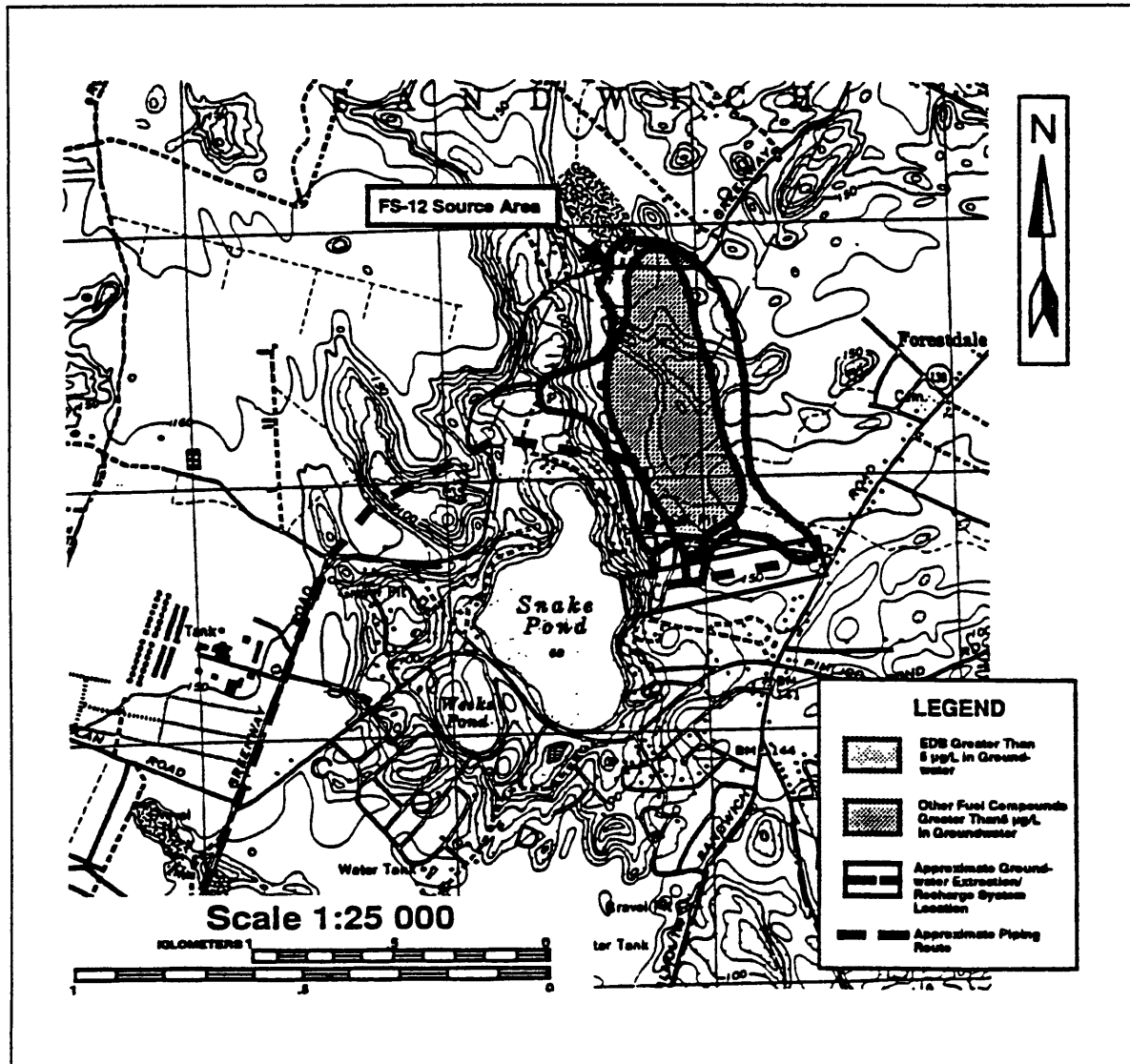

(Stone & Webster, 1995)

Figure 4 - FS-12 Area Map

### 2.2.1.1 Geology of FS-12

FS-12 is located within the Mashpee pitted plain. The Mashpee pitted plain is characterized by coarse grained materials, mostly sands and gravels. The sand and gravel grains become finer with depth. Throughout the entire depth of the outwash there exists discontinuous lenses of fine sands, clays and silts left from ice and glacial sediments. The sand and gravel materials are underlain by the bedrock. In the FS-12

area, the bedrock elevation ranges between 82 to 328 feet below MSL. Observations suggest the existence of fine sands and clay deposits at depths of 130 to 215 feet below MSL (Advanced Sciences, Inc., 1993). It is possible that these sediments are part of a continuous layer of finer materials within the sandy aquifer. However, there is not enough data to verify the existence of a continuous layer of finer sediments (HydroGeoLogic, Inc., 1994).

### 2.2.1.2 Hydrology

FS-12 is located above the Cape Cod aquifer. The aquifer is unconfined and its water table is located on average 80 feet below ground surface. The water table intersects the ground surface creating the following ponds in the area: Snake Pond, Peter's Pond, Mashpee Pond, and Wakeby pond. The groundwater flows in the south-southeastern direction. From the Feasibility Study (Advanced Sciences, Inc., 1993), it was determined that the horizontal hydraulic gradient varies between 0.0003 and 0.00067. The aquifer test indicates the horizontal conductivity to vary between 236.75 and 368.21 feet/day (HydroGeoLogic, Inc., 1994). From the aquifer test other properties were found as shown by Table 1:

**Table 1- Aquifer properties**

Kr horizontal conductivity (ft/day)	Kz / Kr vertical/horizontal conductivity ratio	Ss Specific Storage	Sy Specific Yield
236.75 - 368.21	0.05 - 0.55	0.000001 - 0.00058	0.008 - 0.184

(HydroGeoLogic, Inc., 1994)

The runoff from the site can be assumed to be insignificant due to the high permeability of the soils. The only significant form of recharge to the aquifer is from rainfall. Recharge averages approximately 23 inches/year (Masterson and Barlow, 1994).

### 2.2.2 Site History

The current FS-12 contamination area is the result of an extended leak in a fuel line discovered in 1972. The location of the leak is at the intersection of Greenway Road

and the western entrance to the L-firing range. The pipeline was constructed in the early 1960's. Its main purpose was to transport aviation fuel from Cape Cod Canal to the Air National Guard flight line area. Both aviation gasoline and JP-4 jet fuel were carried in the pipeline. In order to stop the leak, it underwent repairs in 1972. Part of the repairs included the use of contaminated soil as backfill for the excavation. Thus, even after the 1972 repairs, JP-4 fuel entered the subsurface soil and groundwater. The line was later closed in 1973. The IRP has estimated a spill volume of approximately 70,000 gallons, which currently contaminates 11 acres of soil. The plume originating from the FS-12 source area extends 5400 feet in length south-southeast from the spill; 1,100 feet wide; 50 feet thick; and moves 0.75 to 1.35 feet/day.

### **2.2.3 Extent of Contamination**

As estimated from evaluations of organic soil vapor concentrations, benzene and ethylene dibromide (EDB) are the primary contaminants of concern at FS-12. (Figure 4) maps out the extent of soil contamination from an areal view. EDB, a significant organic contaminant at this site, is not a component of jet fuel and was added to the aviation gas as a lead gas scavenger. It is present throughout the dissolved plume, though the free product does not constitute a continual source, as with benzene. When contaminants are not absorbed by soil particles or dissolved into the groundwater, they remain in the free phase form, also known as free product. Being less dense than water, the free product tends to float on top of the groundwater. The free product 'source' of the plume covers five acres ranging in thickness up to 0.7 feet. Near the spill, higher concentrations of benzene and EDB were measured at 1600 ppb and 600 ppb, respectively. The plume extends in an elliptical shape, approximately 5000 feet downgradient (Advanced Sciences, Inc., 1993).

During the remedial investigation of FS-12, it was determined that EDB and benzene posed the largest threat to human health. Their distributions are similar, with the EDB plume located at a slightly deeper depth in the aquifer than the benzene plume (HAZWRAP, 1994). The plumes are depicted in more detail in Appendix B. Risk values were determined for the contaminants of concern based on groundwater exposure and future land use. Most probable carcinogenic risks far exceeded the EPA's upper limit for

cleanup guidelines. Therefore, cleanup processes were promptly initiated. (Advanced Sciences, Inc., 1993)

#### **2.2.4 Current Situation**

After surveying applicable treatment schemes, the IRP selected a combined Air Sparging/Soil Vapor Extraction system to control the source and a well fence to contain the plume movement. The air sparging pilot study was deemed a success for two reasons: (1) the pressure differentials were conclusive enough to predict an adequate extraction well radius of influence and (2) field measurements are indicative of productive vapor extraction in the outwash sands and gravel (HAZWRAP, 1994). A more detailed description can be found in source control, section 3.2.2.

Consequently, an air sparging/soil vapor extraction system was designed and quickly implemented to control the source area at FS-12. The air stripping action of the sparging will transfer contamination from the aqueous phase into the vapor phase and carry it to the unsaturated zone. There it can be captured by the soil vapor extraction wells, and treated with catalytic oxidation and activated carbon in a vapor control unit. The combined system has been running since November 1995, though the first 100 days utilized only the vapor extraction wells. At the March 1996 FS-12 Sandwich Subcommittee Meeting, Ed Pesce of the IRP reported that clean-up of the source area is expected to take two years (HAZWRAP, 1994).

The Plume Containment committee meets regularly, and is involved in design analysis for site remediation. Preliminary designs indicate proposed locations for the five pump and treat wells that will capture and extract a total of 300-330 gallons/minute of contaminated groundwater. This will be treated and reinjected nearby. With an estimated start-up in September 1996, this process is not a final solution, but meets the immediate goals of the MMR in "source control and plume containment." The MMR is not currently planning to reuse any of the treated water, which means that 100% of it will be reinjected. Public perception of water reuse issues indicate a current unwillingness to drink any treated water. (Installation Restoration Program, July 1995). More details pertaining to ongoing FS-12 issues will be presented throughout this paper.

### **3. Findings**

The results from the study of the FS-12 plume are presented in the sections below. First, the model of the plume is completed and analyzed for its effects on local surface water bodies. Second, four treatment alternatives are assessed for potential applications. Finally, water supply issues including future water supply and public acceptance of drinking treated groundwater are discussed. See the appendices for further details on the analyses.

#### **3.1 *Modeling of the Plume***

A finite element model was used to simulate the natural flow of the groundwater. The primary application of the model was to track the contaminants from their source. The potential contamination of Snake Pond, a surface water body southwest of the pipe leak, was assessed using this model.

##### **3.1.1 Model Description and Development**

First developed in 1982 by Camp, Dresser & McKee, the DYN system programs were used to model the FS-12 plume. DYNFLOW solves the governing groundwater flow equation by finite element analysis. DYNFLOW is capable of simulating flow under natural equilibrium conditions, as well as transient conditions induced by pumping. DYNFLOW bases its solution on an elemental grid. The nodes of the model form a three dimensional, trapezoidal element. The head and velocity vectors are calculated for each element in a time step process. Using the results from DYNFLOW, the plume migration was determined using DYNTRACK. DYNTRACK can simulate tracking for a simple single particle. In addition, it can simulate particle tracking for three dimensional, conservative and first order decay contaminants. DYNTRACK can also account for the absorption and dispersion of contaminants. (Camp, Dresser & McKee, 1992)

The first step in the model building process is to create a conceptual model. In order to determine the appropriate location and extent of the elemental grid, the

following were analyzed: (1) topographical and geological maps (U.S.G.S., 1974; LeBlanc et al., 1986; Savoie, 1995), and (2) data from the FS-12 Remedial Investigation and Feasibility Study Reports (Advanced Science, Inc., 1993). The grid used for the model covered a much larger area than the actual contamination (Figure 5 and Figure 6) to appropriately represent and model the local stratigraphy and hydrogeology. The grid was approximately triangular in shape and was defined by three sides. The elements of the grid were made smaller and denser in locations of greatest interest. These regions correspond to the plume, Snake Pond, and the proposed pumping fence location.



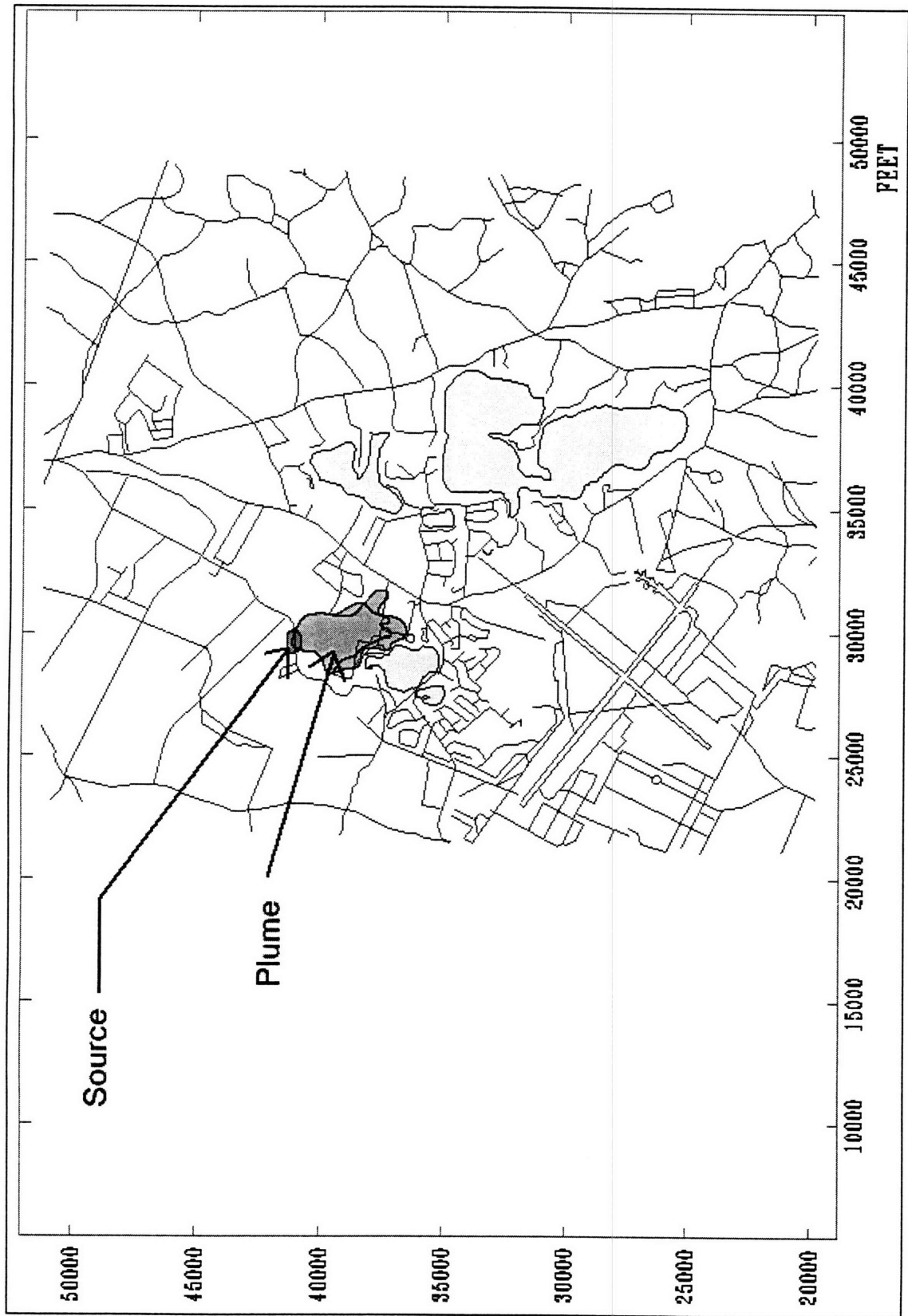

Figure 5- Area Map: Plume Location and Extent of Contamination

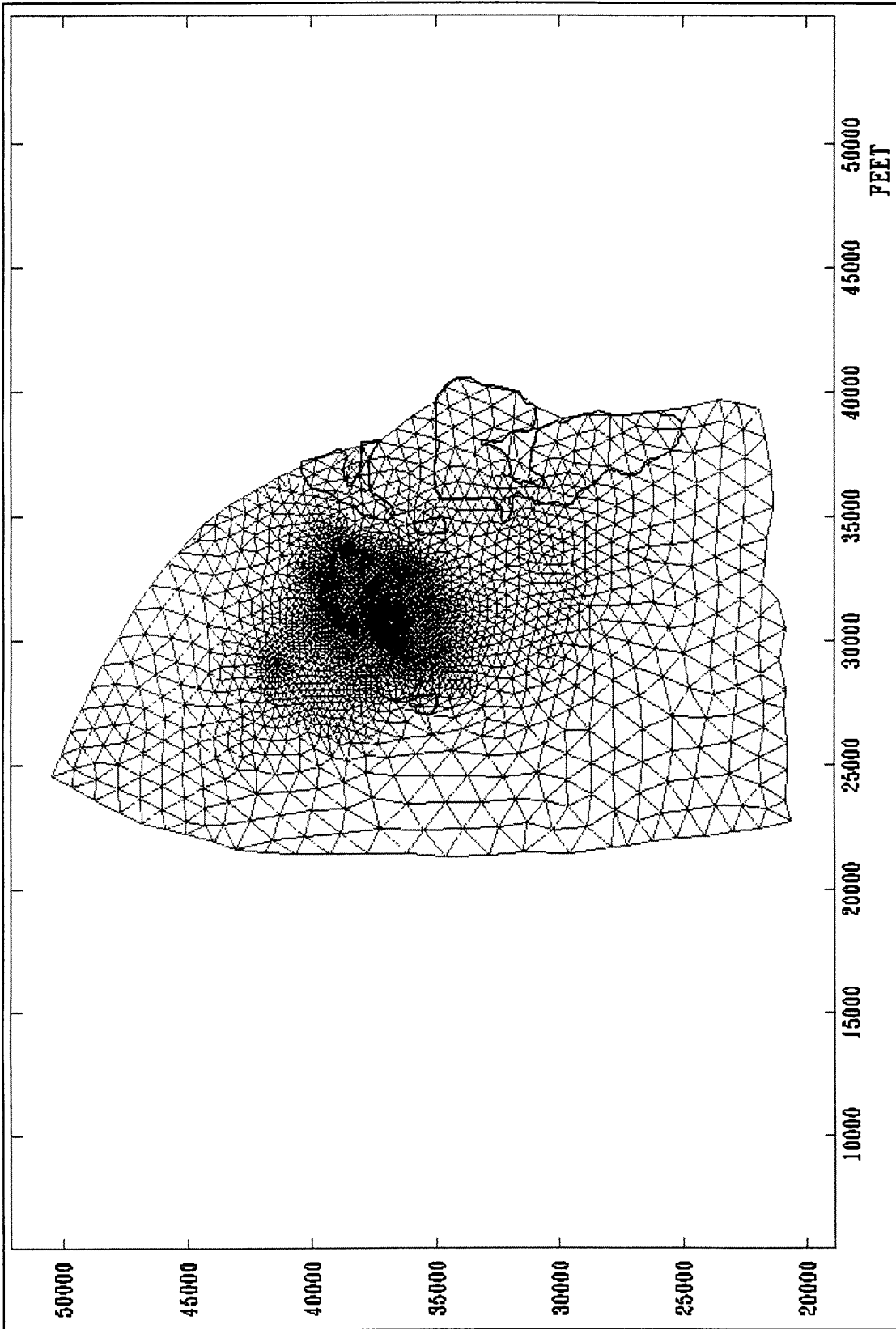
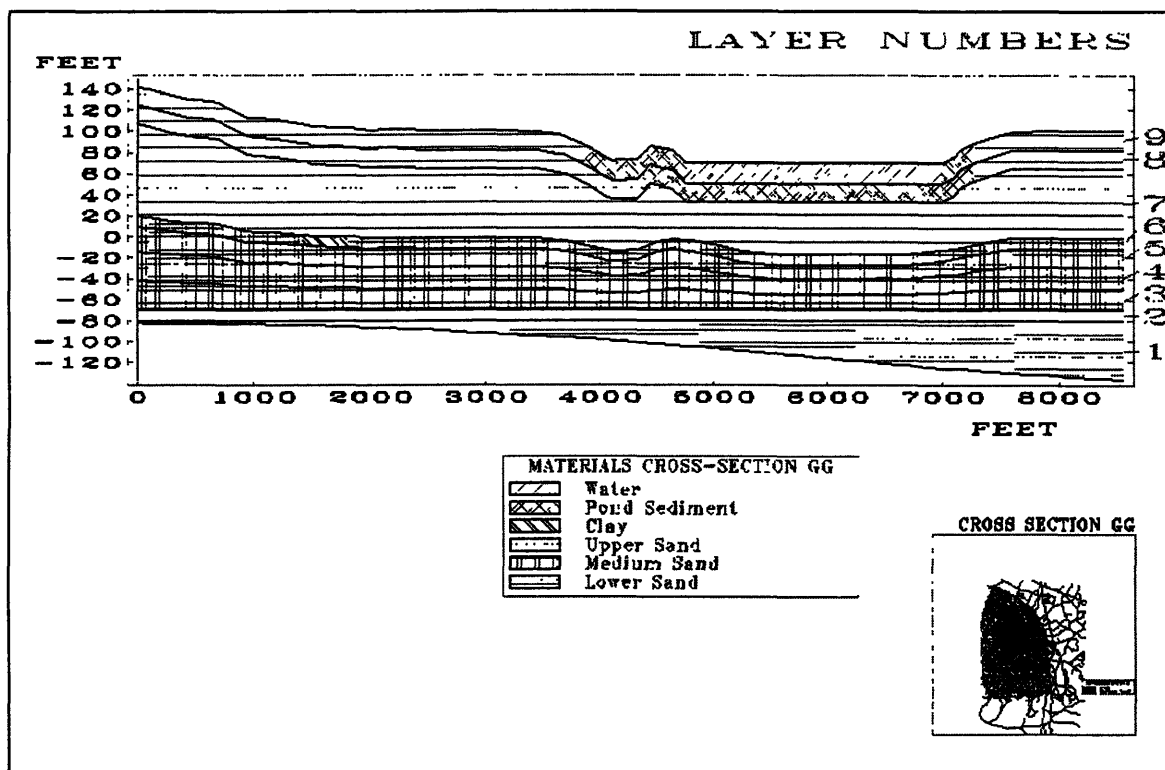

Figure 6- Grid Area

The left and upper right borders of the grid area were modeled as no-flow boundaries. The lower part of the right border, which included Peter's, Wakeby, and Mashpee Ponds, was set at a fixed-head value equal to the water elevations of the ponds. For the bottom perimeter, fixed-head values between 40 ft and 45 ft MSL were specified for each of the nodes.

For the grid area, the bottom of the aquifer was bounded by bedrock from an elevation of approximately 82 to 330 feet below MSL (Oldale, 1969). The ground surface, whose highest point was about 200 feet MSL and the lowest 50 feet MSL, was defined by the topography of the local area (USGS, 1974). In the vertical direction, the model was subdivided into layers, defined between two levels, to represent the different types of soil materials and characteristics. According to the geology, the aquifer was divided into three major layers: upper sand, medium sand, and lower finer sand (Figure 7).



**Figure 7 - Cross-Section Showing Layers and Materials**

To account for minor clay/silty lenses, several sub-layers were included in the top and medium layers. An additional level was built directly below the ground surface to model the ponds' location and hydrologic characteristics at an average depth of 35 feet (Advanced Science, Inc., 1993). Layers generally follow the ground surface topography with the exception of the lower fine sand. This sand layer is bounded between 70 feet below MSL and bedrock at the top and bottom, respectively.

The hydraulic conductivity of the aquifer decreases with depth, and the clay/silty lenses exhibit significantly lower conductivities. Because of the coarse grained quality of the upper sand, the major layer was assigned a horizontal conductivity of 355 feet/day. The medium layer, being slightly less conductive, was assigned a horizontal hydraulic conductivity of 275 feet/day. Since the bottom layer was composed mostly of fine sand with some silty deposits, it was modeled as only one homogenous material with a conductivity of 50 feet/day. The clay/silty lenses were included as one small area in the major medium layer on the east side of Snake Pond where several observations detected clay/silty soil. The horizontal conductivity of the clay/silty soil was set to 19 feet/day. The vertical conductivity was defined in each layer by using the appropriate anisotropy ratio for the Cape Cod aquifer (Advanced Science, Inc., 1993; Masterson and Barlow, 1994) which is 3:1, horizontal:vertical. The elemental model was also set to have a recharge of 23 inches/year (Masterson and Barlow, 1994). The ponds were modeled by attributing a "water" material to the elements that contained the ponds in the sub-layer directly below the ground surface. To represent the action of the ponds correctly, the "water" material was defined to be ideally 100% conductive by setting the horizontal hydraulic conductivity equal to 100,000 feet/day. An additional layer was included beneath the "water" layer to describe the sediments of the ponds. Initially, the conductivity of the sediments was specified to be lower than that of the sand materials. However, in the final model it was set equal to the hydraulic conductivity of the upper sand. This change was made because the sediment layer with lower conductivities does not have a significant effect on the flow field. The elemental grid and layers were then simulated and calibrated for natural flow.

### **3.1.2 Assessment Of Model Results**

#### **3.1.2.1 Natural Groundwater Flow**

The natural flow of the system was reproduced with the DYNFLOW model. In order to assess the validity of the results, the computed hydraulic head values were compared to the observed head values of Savoie (1995). The two sets of hydraulic head values demonstrated satisfactory matches. The mean difference in hydraulic head values was 0.348 feet with a standard deviation of 1.687 feet. Furthermore, the equipotential lines resulting from the model (Figure 8) were close to the equipotentials of the same study. (Savoie, 1995) The flow pattern has a general north-south direction with a slight tilt to the east.

#### **3.1.2.2 Contaminant Tracking**

Since the fuel released from the pipe contains many compounds, the tracking was limited to one contaminant. Benzene was selected because it is highly toxic and soluble in water, exhibiting lower retardation and higher transport velocities than the other contaminants.

The source of the contamination is a pancake-shaped volume of free product which was modeled as a fixed concentration source. The concentration was set equal to the solubility of benzene. The particle path was modeled with the DYNTRACK model and the resulting plume is shown in Figure 9. A cross-section parallel to the plume is also shown (Figure 10).

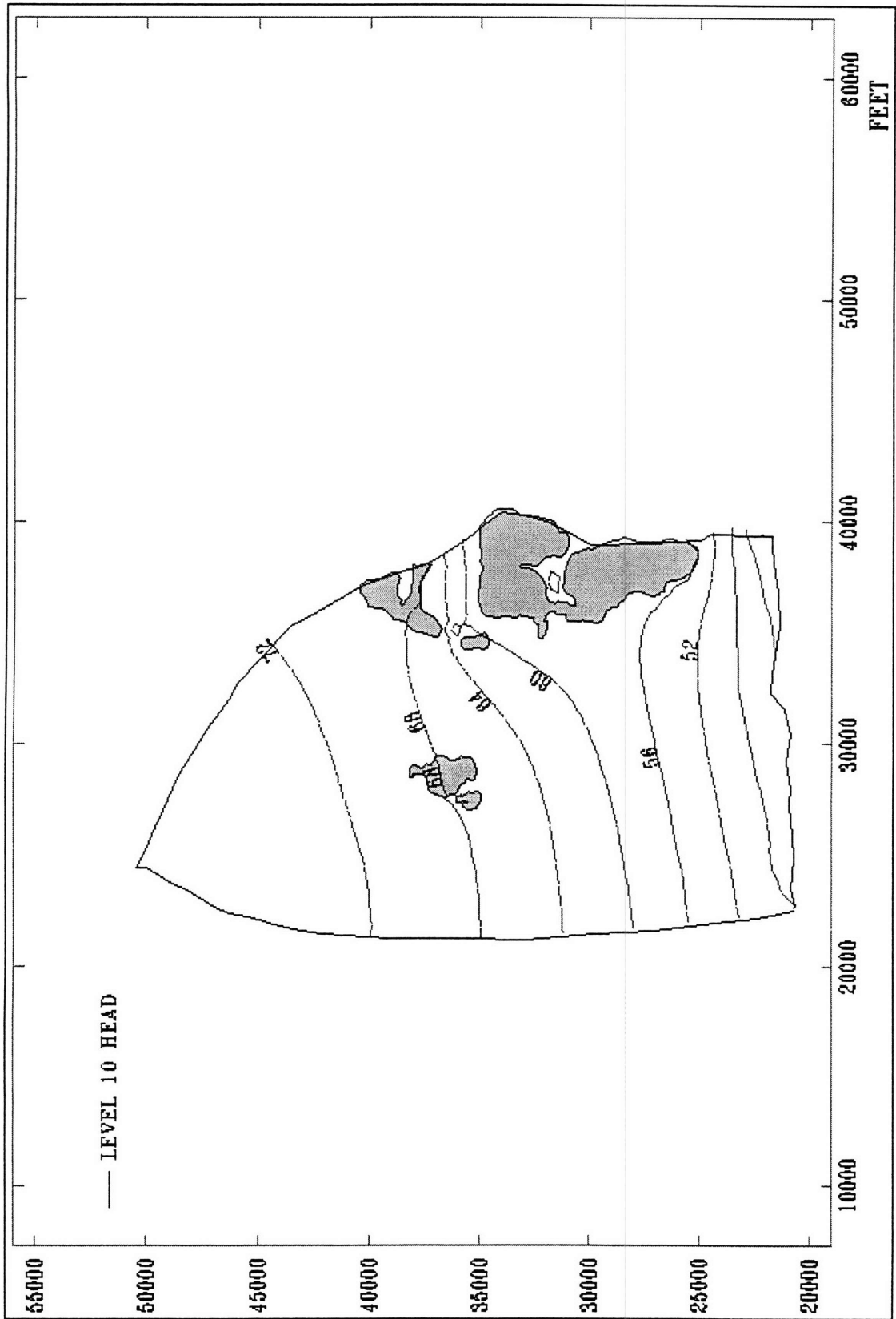

Figure 8 - Water Table Elevations (feet)

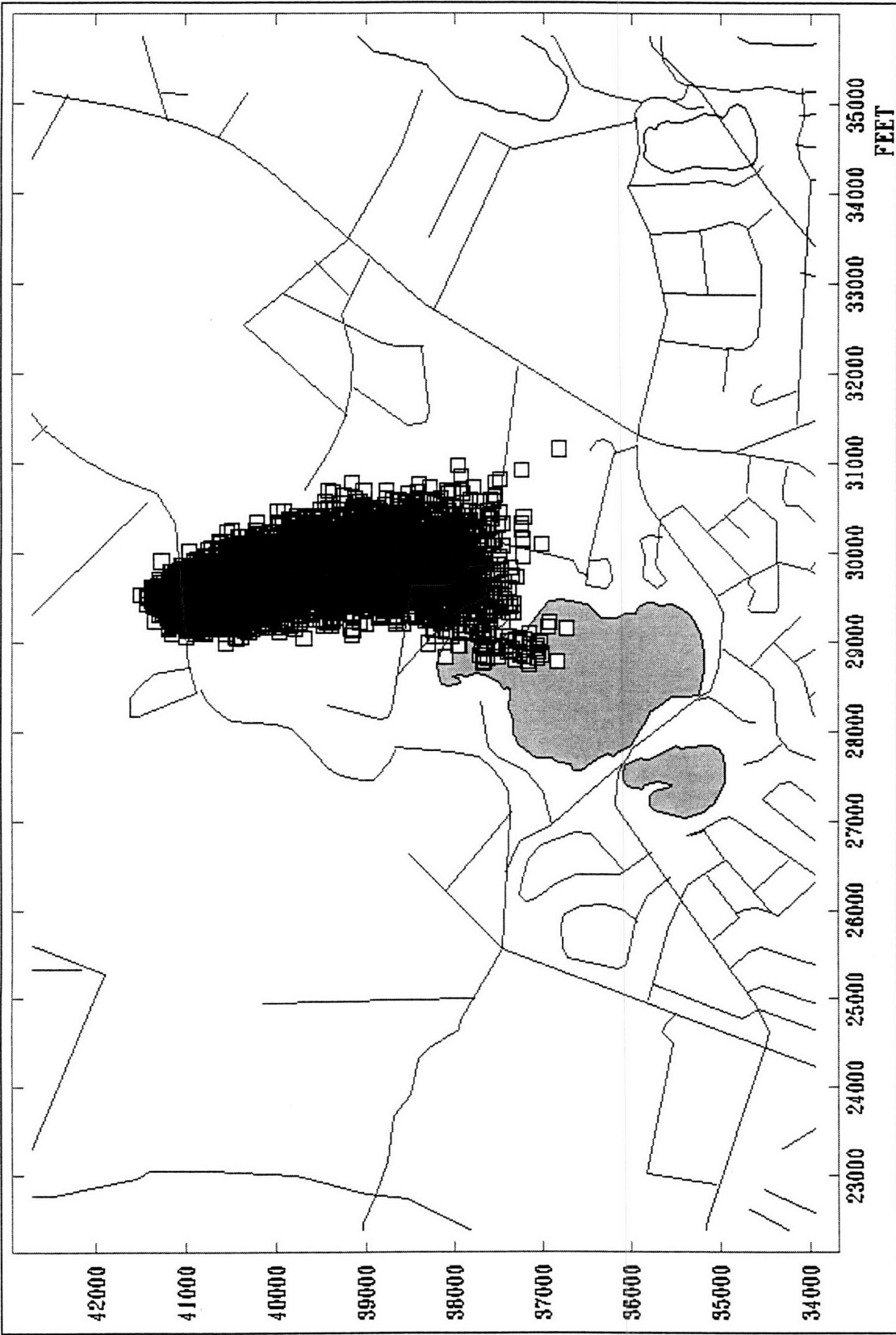

Figure 9 - Simulated Benzene Particles

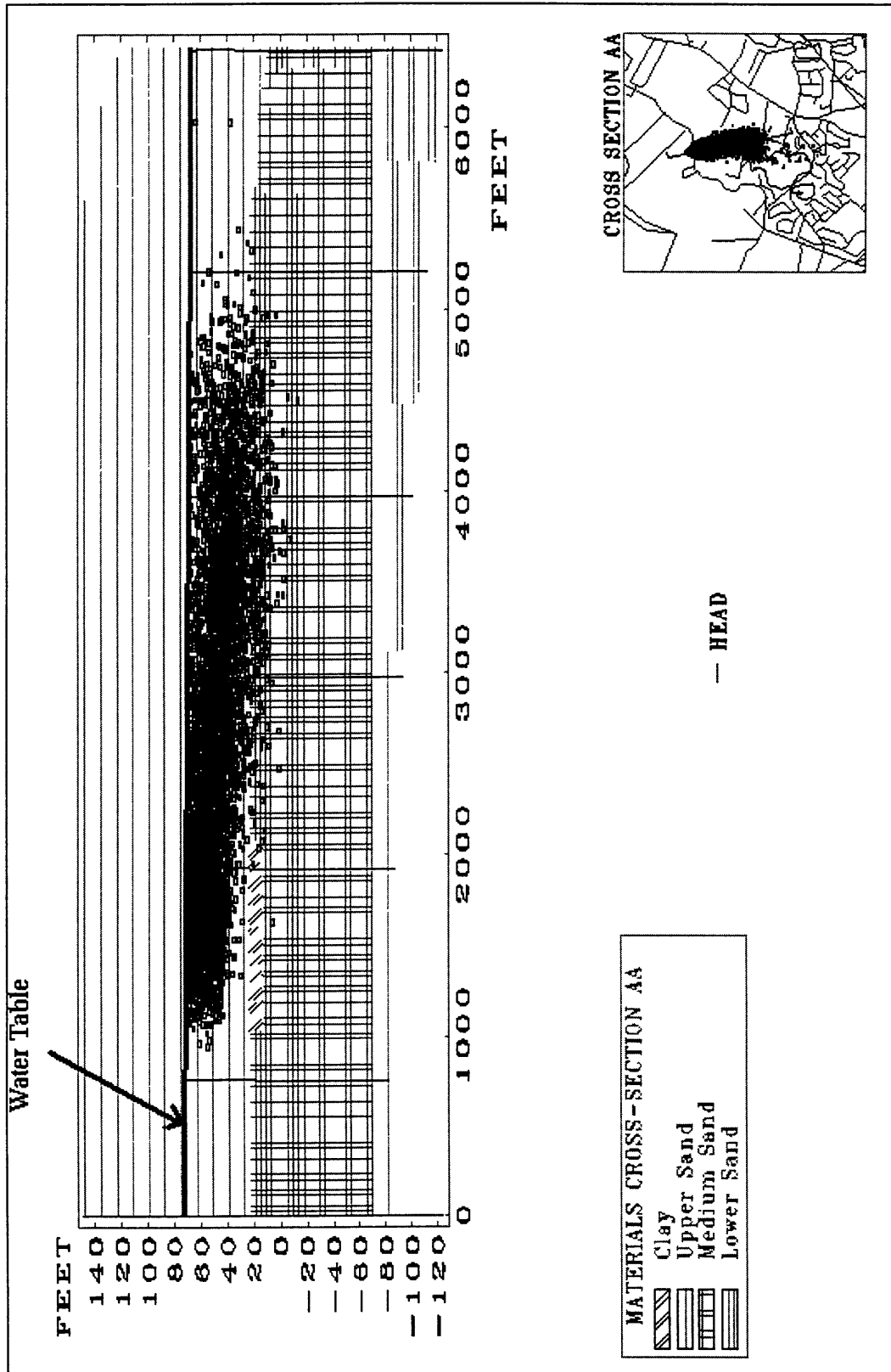

Figure 10 - Cross-Section Across Plume



The position of the modeled plume is approximately 20 feet higher than the measured concentrations of benzene. The discrepancy is attributed to the uncertainty regarding the location of the groundwater divide. It is suspected that the actual position of the divide is closer to the source than the distance input into the model; due to the sparseness in the head observations in the divide area, this cannot be confirmed at this time. Closer proximity to the divide would result in more pronounced vertical movement of the plume. Since the modeled plume is closer to the ground surface, it is also closer to the pond. Therefore, the results of this simulation will represent a highly conservative model. If the resulting benzene concentration in the pond is insignificant, despite the proximity of the modeled plume to the pond, Snake Pond will be safe in reality.

### **3.1.3 Surface Water Impacts**

Despite the inconsistencies of the plume position, valid predictions can be made concerning the safety of Snake Pond. Since the placement of the modeled plume is higher than actual measurements show, it can be considered a 'worst-case scenario.' A cross-section of Snake Pond (Figure 11) shows very few particles being released in the pond even with this conservative model. The resulting concentration was less than 0.5 mg/L, well below EPA standards. Therefore, it is safe to say that the pond is not in danger of contamination from FS-12.

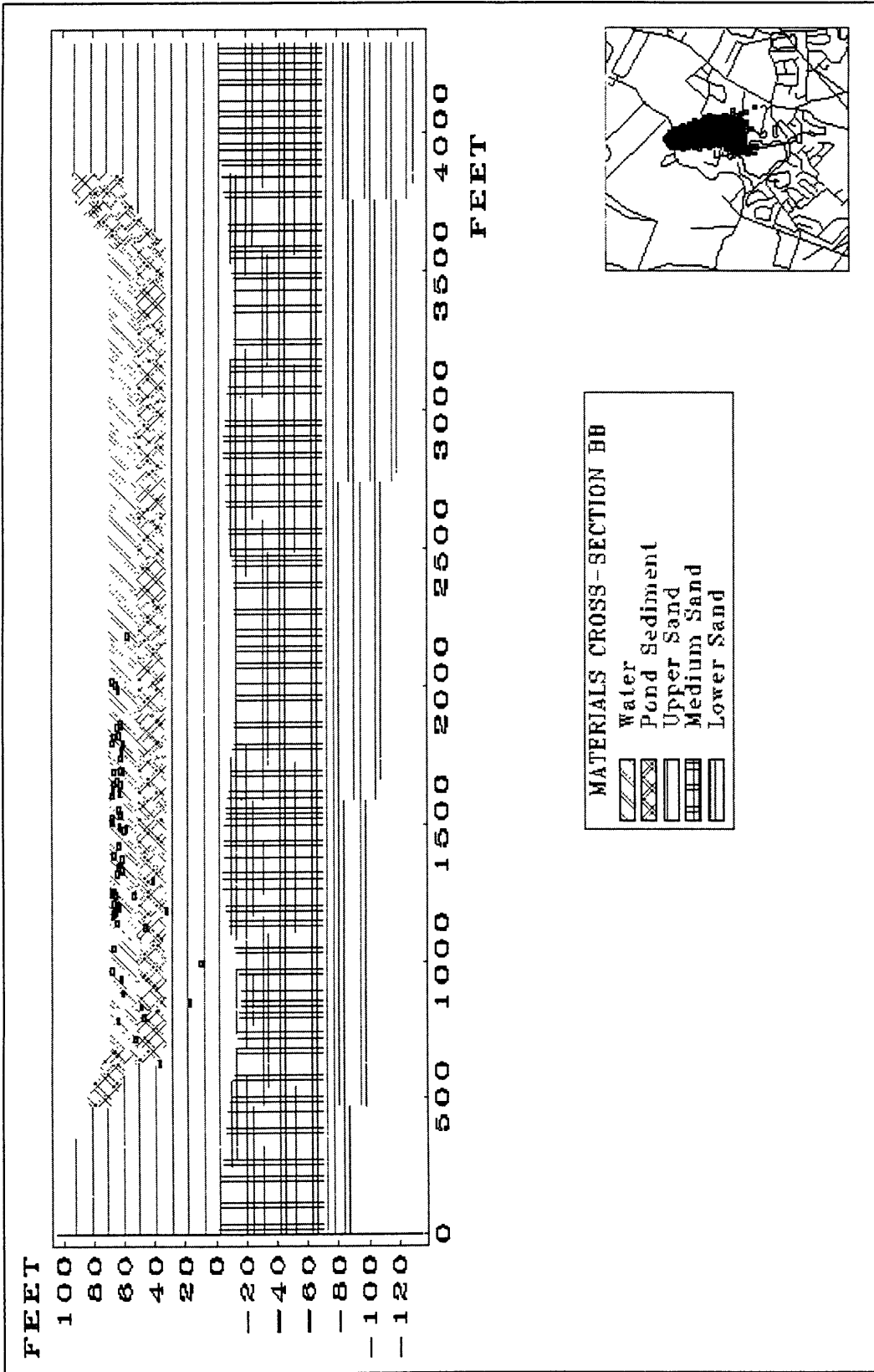

Figure 11 - Cross-Section Across Snake Pond Showing Particles

## **3.2 Treatment Alternatives**

Two primary goals of the IRP are to control the source of contamination and contain the plume's movement. The first treatment alternative presented in this section is the "do nothing" alternative. It is used as a comparative analysis for remedial action extraction. The study also includes an air sparging system to control the source, a well fence and a reactive wall technology for plume containment.

### **3.2.1 No Action Alternative**

The no-action alternative relies solely on natural attenuation to degrade contamination in the groundwater. This section describes the many natural processes that are involved with natural attenuation: biodegradation, volatilization, and adhesion. Calculations of expected costs are also included. Given this background, the application of the no action alternative to the FS-12 plume is discussed.

#### **3.2.1.1 Background Information**

The National Contingency Plan states that it is appropriate to evaluate a limited number of alternatives for interim remedial actions rather than the full range of alternatives typically assessed for final remedial actions. Accordingly, two remedial alternatives were developed and evaluated in the Plume Response Plan: No-Action and Plume Containment. The no-action alternative provides a baseline for comparison for other alternatives. This alternative relies on natural attenuation to treat contaminated groundwater. The Record of Decision states that this alternative is not acceptable because it does not reduce risk and would not meet the following response objectives:

- reduce risks to human health associated with the potential future consumption and direct contact with groundwater and surface waters
- protect uncontaminated groundwater and surface waters for future use by minimizing migration of contaminants

- reduce potential ecological risks to surface waters and sensitive coastal waters through the implementation of the containment system
- reduce time required for aquifer restoration

### ***3.2.1.2 Process Description***

Natural attenuation is not in itself a groundwater containment or a treatment technology. This approach relies on natural subsurface processes such as dilution, volatilization, biodegradation, abiotic oxidation, and adsorption to reduce contaminant concentrations to acceptable levels. Application of natural attenuation involves evaluation of site characterization data, modeling of fate and transport processes based on that data, continual field monitoring to provide evidence showing that degradation of contaminants is occurring naturally at an acceptable rate. (USEPA, 1993) Processes involved with natural attenuation are described below.

#### ***Dispersion and Dilution***

The mechanical mixing of flowing water with contaminants is called dispersion. The most important effect of dispersion is to spread the contaminant mass beyond the region it would otherwise occupy. Dilution is the result of the mechanical dispersion spreading the mass of contaminants over a larger volume and mixing with clear water. This results in a reduction in contaminant concentration.

#### ***Volatilization***

Volatilization is the conversion of volatile chemical constituents in groundwater to vapor, which is ultimately transferred to the atmosphere. Natural volatilization is likely to occur in shallow unconfined aquifers. Volatilization rates in surface waters is expected to be much higher. Field studies have shown half-lives ranging from 5 hours for benzene to 6 hours for EDB for evaporation from a river of 1 meter depth with wind speed of 3 meter/second and water current of 1 meter/second (MacKay et al., 1992). These values are of particular interest to determine the impacts of potential plume discharge into streams and ponds.

### *Sorption*

Retardation processes consist of sorption of organic substances. Sorption can contribute to the attenuation of the concentration of contaminants. It reduces the rate of movement of contaminants as compared to the average flow rate of groundwater.

### *Biodegradation*

BTEX compounds are known to biodegrade easily in groundwater. Biodegradation processes are studied in detail in a later section.

#### **3.2.1.3 Application at FS-12**

The IRP gave little consideration for the no-action alternative for natural restoration and impacts on environment and human health. The long range model depicts key facts about the FS-12 plume (Figure 12):



**Figure 12 - Long-Term Contaminant Transport**

- the plume will not discharge into Snake Pond (see Appendix A for details)
- the plume will discharge into Mashpee Pond in approximately 35 years assuming a groundwater flowrate of 0.5 feet/day (see Appendix A for details)

Based on the simulations described above, two exposure pathways have been identified:

- plume discharge in Mashpee Pond

- consumption of water from contaminated public and private wells

The following will examine the natural attenuation processes and exposure risks of plume migration. Potential impacts of plume discharge in Mashpee Pond are also discussed.

**Table 2- Contaminants of Concerns: Comparison of Average and Maximum Concentrations in the FS-12 Plume Against Established MCLs**

<b>Contaminant of Concern</b>	<b>Average Concentration (mg/L)</b>	<b>Maximum Concentration (mg/L)</b>	<b>MCL (mg/L)</b>
Benzene	65.1	1550	5
EDB	21.4	578	0.05

(Operational Technologies Corp., 1995)

The contaminants of concern in the FS-12 plume are benzene and EDB (Table 2). Benzene is expected to undergo aerobic biodegradation. This conclusion is supported by both the presence of shorter chain hydrocarbons and low levels of dissolved oxygen within the plume. However, low dissolved oxygen concentration in the areas of highest benzene concentrations suggest contaminant levels have overcome the capacity of the biological system. Studies have shown that benzene will migrate by advective transport until areas with sufficient dissolved oxygen levels are encountered. At that location, biological activity can reach equilibrium with the rate and concentrations at which benzene migrates further in the aquifer (Cambareri et al., 1992). EDB has been shown to undergo both aerobic and anaerobic degradation processes in laboratory and field studies. However, relatively low concentrations of EDB overcome the capacity of the biological system. Degradation rates are not expected to match the rate of groundwater flow. Therefore, the EDB plume will continue to migrate. Table 2 compares the average and maximum concentration levels with the MCLs (Operational Technologies Corp., 1996).

Assuming first order decay, the time required for complete dissolution of contaminants to MCLs was calculated as 4.5 years for EDB and 8.3 years for benzene.

According to these biodegradation rates, the maximum additional extension of the plume exceeding MCL limits is 1000 feet downstream of the current plume toe.

However, studies have shown that the rate and extent of biodegradation are strongly influenced by the type and quantity of electron acceptors present in the aquifer. Once the available oxygen, nitrate, and sulfate are consumed, biodegradation is limited and is controlled by mixing aerobic biodegradation at the plume fringes (Borden et al., 1995). Therefore, a combination of natural attenuation with source control; such as free product recovery or air sparging, would significantly enhance biodegradation and the biodegradation rates could be met with greater confidence.

These results suggest that risks posed to the environment due to plume discharge in surface waters may be much less than those stated by the MMR Installation Restoration Program. Their risk assessment study assumes potential concentration levels in the environment would equal the current ones found in the plume, thereby neglecting attenuation processes such as biodegradation. This leads to overly conservative results. However, current concentrations of contaminants do pose a threat to private wells, at least until attenuation processes have decreased contaminants levels below the MCLs.

### **3.2.2 Source Control - Air Sparging**

The purpose for this study is to evaluate air sparging as an appropriate choice for source control at FS-12. It includes a basic description of the system processes, as well as primary mechanisms for contaminant removal. The main goal is to determine a new time estimate for source remediation.

#### **3.2.2.1 Background Information**

Air sparging is predominantly used to treat soil and groundwater that is contaminated with volatile organic compounds (VOCs) or petroleum hydrocarbons. The technique involves air injection into water saturated zones. Through a combination of volatilization and biodegradation organic contaminants are removed. Air sparging has a broad appeal due to its relatively simple implementation and modest capital costs which compare favorably with other remediation treatments. Several field-scale applications



indicate air sparging's effectiveness in remediating groundwaters contaminated with dissolved VOCs at a faster rate and 50% lower cost than pump and treat. (Chao, 1995). As an *in situ* process, it meets an important provision of the Superfund amendments that calls for minimal exposure to the public and nearby environment. Sparging does not require groundwater extraction and treatment, is operationally low maintenance, and can be adapted to serve a variety of special situations.

### **3.2.2.2 Process Description**

Air sparging involves the injection of a hydrocarbon free gaseous medium (typically air), under pressure, into the saturated soil zone (see Figure 13). Air traverses upward through the saturated zone as it mixes with dissolved and adsorbed phase contaminants. In the vadose zone contaminated air is extracted and pumped to on-site vapor treatment units. Ideally, the vacuum extraction rates are three to four times greater than the sparge rate. This ensures the capture and treatment of all escaping contaminant vapors.

### **3.2.2.3 Primary Mechanisms and Design Parameters**

The key mechanisms incorporated in this technology are volatilization, biodegradation, and mass transfer. Contaminants are transferred, or redistributed, to the

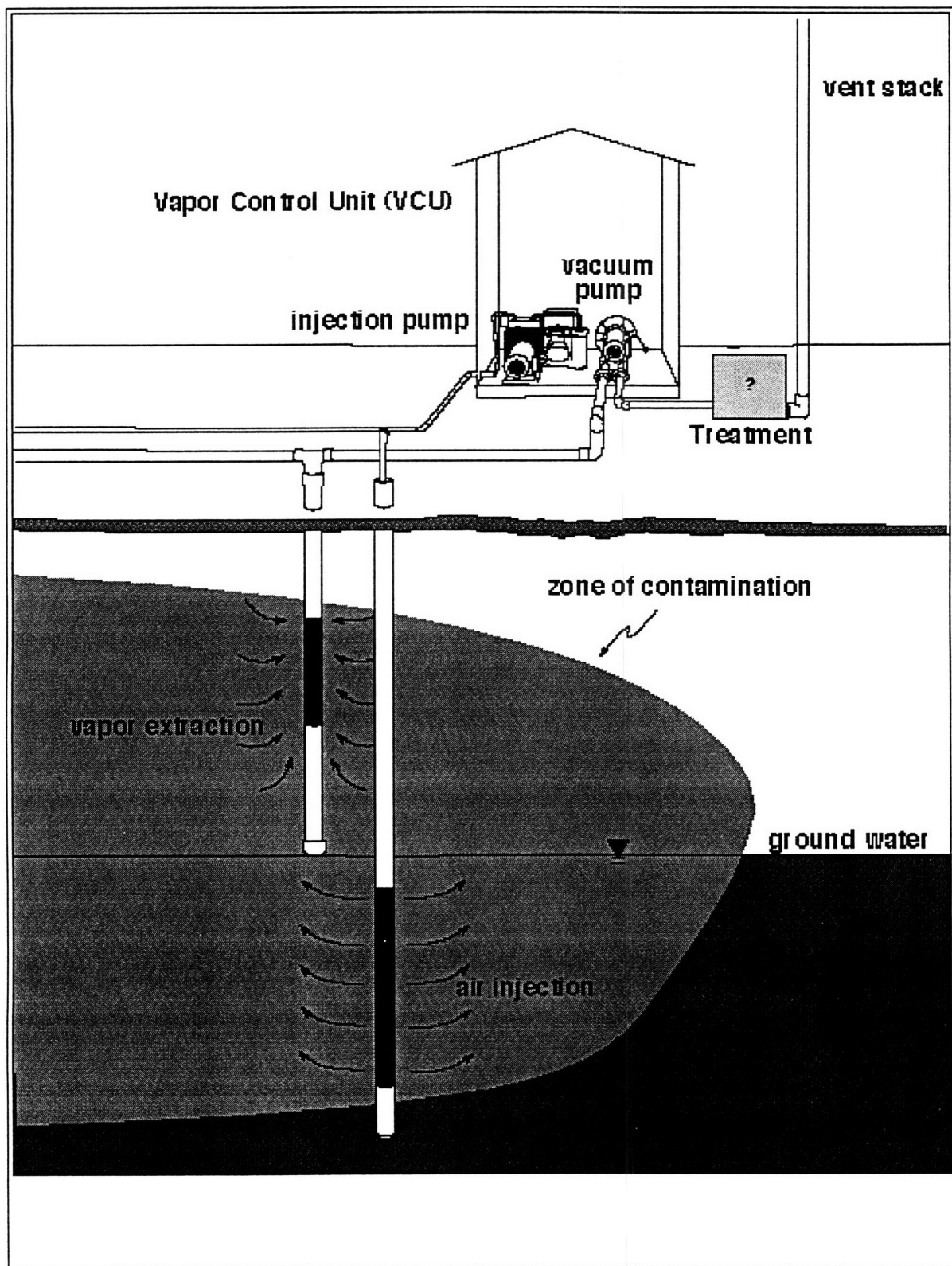

(<http://www.aristotle.com/Sparging/TechResponses/whatis/ResponseMeny.html>)

**Figure 13 - Combined Air Sparging/Vacuum Extraction Diagram**

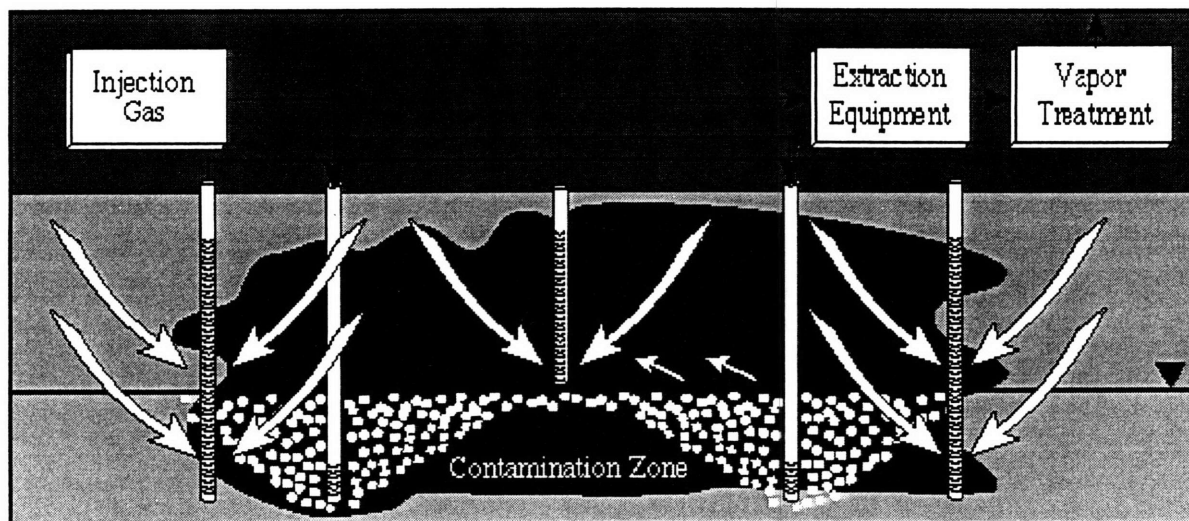

(<http://www.terravac.com/TVtoolsas.html>)

**Figure 14 - Air Sparging (Sparge VAC)**

advective vapor phase through an established contaminant gradient between the solid/liquid and gas phases. Here, oxygen is exchanged into the aqueous phase. VOC transport into the sparging air results from diffusion/dispersion and air-induced circulation of the water in the vicinity of the sparging well (Wilson, 1994). Percent removal efficiencies of VOC's are proportional to the injected air flowrate and Henry's law constant. "Henry's law constant is a partition coefficient defined as the ratio of a chemical's concentration in air to its concentration water at equilibrium." (Hemond, 1992) To achieve effective stripping via sparge wells, contaminants must have a Henry's constant greater than 0.01, a vapor pressure greater than 0.1 mm Hg, and a soil/water partition coefficient less than 1000 (In Situ Aeration, 1995).

Bioremediation provides a second simultaneous pathway for removal (destruction) of the VOCs. Although "bioventing" is frequently discussed as a separate technology, both evaporation and bioremediation will occur whenever there is air movement through soil (Mohr and Merz, 1995).

For air sparging to be effective, air must be able to flow freely through the aquifer. Thus, air sparging is most widely applicable within sandy soils. A hydraulic conductivity of 0.001 centimeter/second is necessary to maintain sufficient subsurface air flow, since horizontal impermeable zones can trap air and push contamination downward or laterally.

The air sparging 'radius of influence' can be defined in the field through a process of dissolved oxygen measurements, pressure changes, groundwater mounding, or tracer gases. It is important to determine this parameter to evaluate the probable effectiveness of the air sparging technology. Radius of influence is defined as the distance from an air sparging well where air flow can be detected or where the effects of air contact, groundwater mixing, or groundwater oxygenation are detectable (Marley, 1995). The influential radius is rarely radially symmetric. An EPA survey of 21 sites using *in situ* air sparging reports influence ranging from five to 177 feet, though typically less than 25 feet. These distances are directly affected by factors such as soil type, well depth, and injection pressure and flow rate (Loden, 1992).

#### **3.2.2.4 System Limitations**

As with all remedial technologies, air sparging has its limitations. In an operating air sparging/soil vapor extraction system, it is essential to keep the rate of extraction higher than the inflow sparging rate, thus maintaining a favorable gradient of vapor travel. Regardless of flow rate, off-gas concentrations are shown to exhibit an initial sharp decrease followed by proportionally smaller changes in contaminant concentrations with time, a characteristic often attributed to diffusion limitation.

As described previously, the air injected below the water table displaces water as it makes its way up towards the surface and actively strips VOCs from portions of the porous medium. Laboratory evidence indicates that the injected air may flow preferentially through a system of discrete air channels (Ji, 1994). Discrete air flow patterns may lower the effectiveness of treating an entire contamination zone and restrict the distribution of dissolved oxygen to zones near the discrete air-filled channels (Baker, 1995). It can also lead to the risks of lateral mobilization and off-site migration of VOCs. Initial field testing and experiments are usually necessary prior to the implementation of this technology; though they are basically run by trial and error, the potential benefits to be gained demand such an effort (Baker, 1995).

### **3.2.2.5 Applications at FS-12**

The system installed at the FS-12 plume for source control covers five acres and includes 21 sparge wells below the water table and 22 extraction wells in the unsaturated, vadose zone. The radii of influence used in the design are larger than average but still feasible for sandy soil type aquifers with high conductivity and very deep water tables. See appendix B for more comparative data. The design influence for the sparge wells, as determined by the pilot study, is taken to be 75 feet, and for the soil vapor extraction (SVE) wells is 90 feet. The system incorporates an overlapping design to augment complete source area remediation and capture of the volatilized contaminants (HAZWRAP, 1994). The SVE system began running in October, 1995, and continued for approximately 100 days before air sparging began. This staggered start-up also helped to deter any VOC's from escaping into the atmosphere.

The remediation time for source clean-up at FS-12 was estimated based on the computer program, "Venting", along with outputs from a numerical air sparging model to predict groundwater clean-up rates (HAZWRAP, 1994). The IRP has allotted two years for sparging in order to volatilize enough fuel components to keep the remaining residuals below MCLs. It is important to note that volatilization is the only mechanism taken into account in this approximation. A complete cost estimate for the design, implementation, operation and maintenance of this system comes to almost 2 million dollars (Davis, 1995).

### **3.2.2.6 Alternative Remediation Rate Model**

A significant step in the critical analysis of this treatment alternative was to recalculate remediation times for site cleanup. Due to the initial urgency of process design and construction, many explicit, and sometimes implicit, assumptions were used to determine initial remediation rates. (See Appendix B for details). The current model takes the existence of pure phase free product to be the limiting factor for complete hydrocarbon volatilization. The new time calculation acknowledges the individual respective rates of volatilization for each VOC component in JP-4 jet fuel. Using mole fraction calculations and corresponding partial vapor pressures, this process accounts for the fact that some components of fuel will volatilize more quickly than others. By

assuming a state of equilibrium within each sparged volume of air, a new fuel volume can be calculated. This leads to iterative chemical concentrations and adjusted pressures within the sparged air.

As a source control treatment alternative, air sparging is an optimal choice for the site conditions at FS-12. The sandy soil and the contaminant's volatility present a cost-effective and efficient opportunity for air sparging/soil vapor extraction system remediation.

### ***3.2.2.7 Time For Contamination To Reach MCLs***

Based on the spreadsheet model, the mole fraction of benzene in the fuel would need to be reduced to  $1.33 \times 10^{-6}$  in order for an equivalent groundwater near the source to measure below the MCL of 5 ppb. According to the graphs in Appendix B, sparging would have to continue for longer than 9 years to reach these levels. It is important to note that this model takes only removal by volatilization into account. Although the transfer of VOCs into the vapor phase is the dominant process, other mechanisms that contribute to decreasing organic concentrations in the aquifer include biodegradation, dispersion, sorption, and dilution. In addition, the groundwater concentrations measured here are assumed to be directly adjacent to the free product pancake before any dispersion or dilution occurs.

Another way to analyze these results is at the conclusion of the previous remedial estimation time of two years. After two years of simulated sparging and vapor extraction, the mole fractions of fuel components were transformed into water concentrations. The corresponding volumes of clean groundwater needed to dilute each liter of fuel-contaminated water near the source to 5 ppb were calculated to be 285 liter/1 liter of contaminated water.

Air sparging may not be as effective if there are significant amounts of less-volatile compounds present in the plume. As seen from the graphs in Appendix B, the less volatile component curves exhibit lower rates of volatilization. Correspondingly, they are present in much lower incidental concentrations, and are more subject to the bioremediation mechanism of removal. Since the BTEX component concentrations are the primary regulated and measured contaminants at the FS-12 site, they are the basis

for comparison of the model outputs. More detailed explanations of the modeling process and results can be found in Appendix B.

### **3.2.3 Plume Containment**

#### ***3.2.3.1 Pump and Treat - Extraction Well Fence***

The following provides the necessary background, design, and application of a pump and treat system for the containment of the FS-12 plume. The design provides an extraction well fence that controls additional migration and spreading of the current contamination. The well fence is not intended to remediate or eliminate the entire plume, but it ensures that the dissolved contaminants do not spread further. In addition, the water contained by the extraction fence will be removed and treated by activated carbon filtration.

##### **3.2.3.1.1 Background Information**

Pump and Treat is one of the oldest techniques for the remediation and containment of groundwater contamination. Although it has been replaced and surpassed in certain instances by other more efficient remedial technologies, it is still widely used for remediation of contaminated groundwater. Pump and treat consists of pumping contaminated water from the aquifer and treating the water to remove the contaminants. The “clean” water can then be either re-injected into the aquifer by injection wells, or retained for other uses. Optimal field conditions for the application of pump and treat at a contaminated site are highly conductive aquifer material and coarse grained and sandy soil in the saturated zone. It is possible to use pump and treat in less conductive materials; however, the required increase in pumping rates would necessarily increase costs of operation. (Domenico and Schwartz, 1990; Member Agencies of the Federal Remediation Technologies Roundtable, 1995).

##### **3.2.3.1.2 Process Description**

The location and pumping rate of the wells depends on the position, depth and extent of the plume. Usually wells are drilled surrounding the contaminated area, down-gradient of the direction of flow. The screening interval is typically positioned at a depth equal to that of the plume. The length of the actual screen is proportional to both the vertical extent of the contamination and to the applied pumping rate. There is a trade off between the number of wells and the pumping rate required to successfully contain the plume. To determine the most efficient design, capture curves are used. These define the volume of water of the aquifer that is being captured by a particular system of pumping wells. Therefore, the total area of influence of the extraction fence will be proportional to the total number of wells and their respective flowrate. The treatment of contaminated water by granular activated carbon is a very common process of water purification. The water extracted by the well fence is passed through tanks containing granular activated carbon on which the contaminants are sorbed (Domenico and Schwartz, 1990; Member Agencies of the Federal Remediation Technologies Roundtable, 1995).

#### 3.2.3.1.3 Implementation and Design

The first step in the design of a well extraction system is to determine the location and extent of the plume. The well fence should be approximately located at the toe of the plume just down-gradient in the direction of flow. Various layouts for the well fence can be produced. For each layout, several systems can be designed with different numbers of wells and different pumping rates. To actually test and analyze the results of the various designs, the groundwater finite element model was utilized (see Section 3.1). To determine its position in space and time, the volume of contaminated groundwater was represented by visible particles. The particles represent the groundwater as it flows through the aquifer. They can be positioned and started at a particular cross section of the contaminated plume. Their flow path can be analyzed in time by selecting the desired time step for the model's simulation. When the model containing the extraction well fence is simulated it is possible to determine whether the flow volume of the plume, as represented by the particles, is captured by the wells. The particles can be analyzed in three dimensions to ensure that the entire plume is



captured. In addition, particles surrounding the actual contamination were also included to ensure that clean water was not being unnecessarily captured by the well fence. Each pumping well was defined in the model by a nodal point with the same coordinates to which the proper outflow was assigned. The model was then simulated under transient conditions to analyze the flow and determine if the extraction well fence actually captures the plume. The capture curves were then determined by analyzing which and how many of the flow particles are being captured by the wells in the simulated model. The analysis of different systems of wells was based on an optimization method. Several solutions were tested with different numbers of wells and different flow rates. The various solutions were then plotted on graphs displaying the interdependence of number of wells, required pumping rate, and depth of the screening intervals.

#### 3.2.3.1.4 Application at FS-12

The most efficient system for the well extraction fence consisted of 11 wells pumping at a total rate of 800 gpm. The well fence layout and location is shown in Figure 15. Figure 16 and Figure 17 summarize the results of the simulations of contained particles in plan view and vertical cross section, respectively. The screening interval was located approximately between 40 and 70 feet below mean sea level (MSL). As shown in Figure 17, the zone of influence of the well system extends well above the screening interval, as much as 40 feet above MSL. However, below the well screens the capture curves do not penetrate the aquifer as deeply as above them. This is due to a zone of high conductivity above the well screening intervals and a low conductivity layer underneath. In plan view the extension of the capture curves is such that only the volume of contaminated water is contained. The horizontal extension of the zone of influence is limited by the presence of the pond. To effectively capture the volume of contaminated water the wells closer to the pond tend to draw clear pond water in addition to the volume of polluted water. Therefore, the two wells next to Snake Pond were assigned higher flow rates of 83 gpm per well in order to capture the plume. However, the pumping rate of the other nine wells was assigned a flow rate of 70.5 gpm per well. Further details on the extraction well fence design can be found in Appendix C.

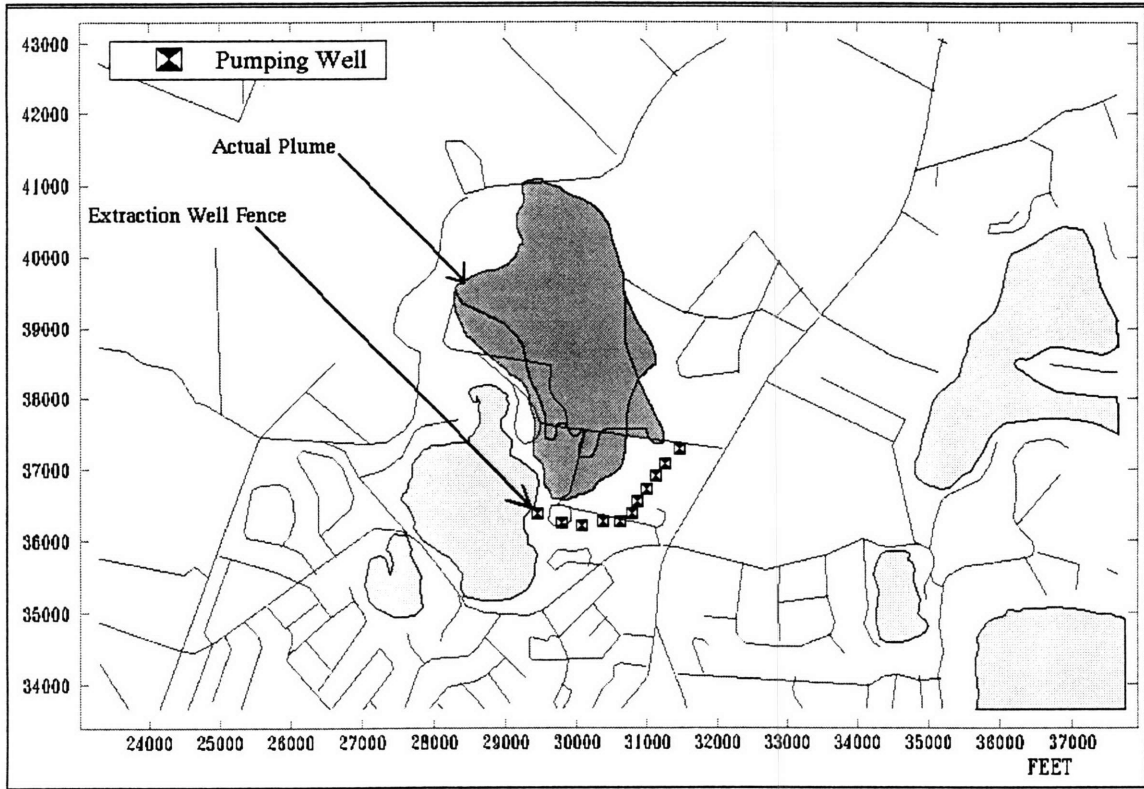

**Figure 15 - Extraction Well Fence and Observed Plume Location**

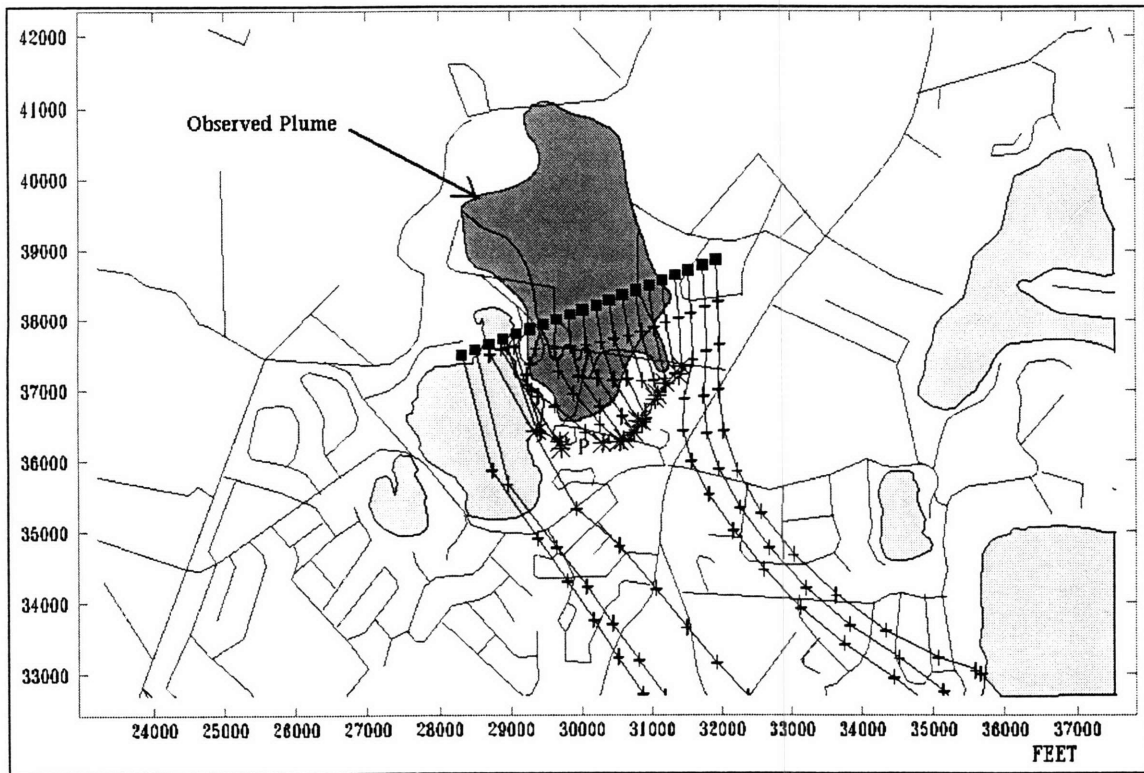

**Figure 16 - Plan View of Particle Capture by Extraction Well Fence**

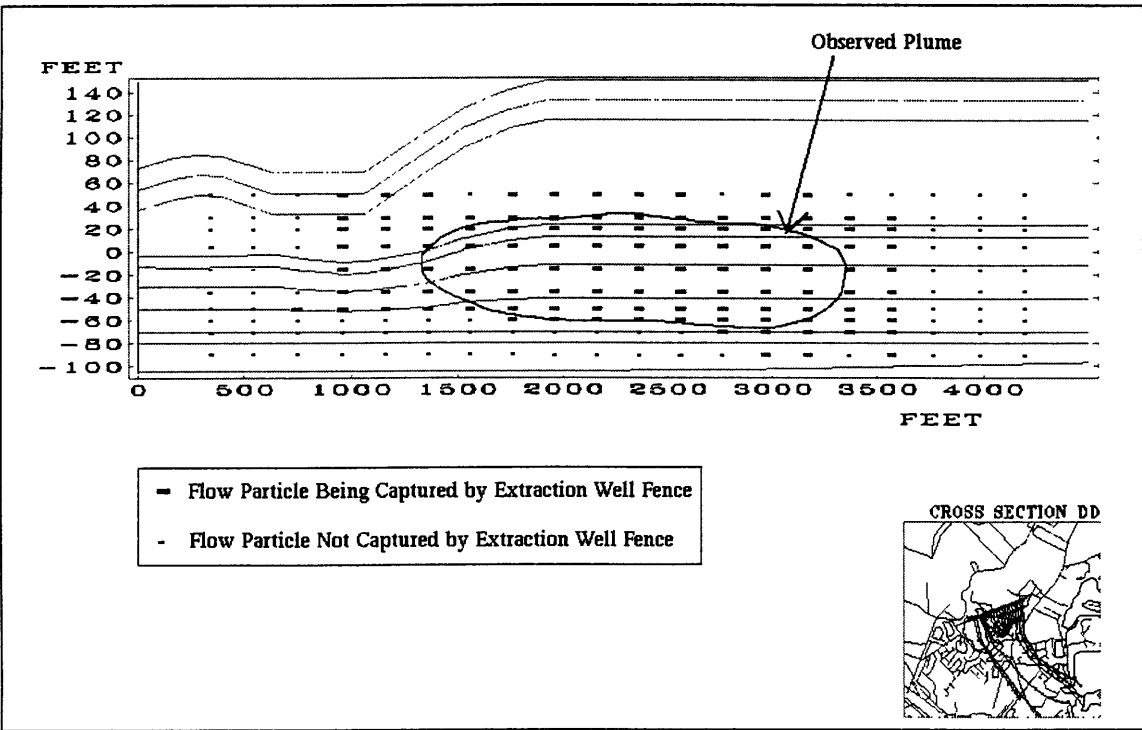

**Figure 17 - Cross Section of Particles Captured by the Extraction Well Fence**

**3.2.3.2 Reactive Wall**

This section will provide a brief summary of the technical workings of the reactive wall as it applies to the degradation of halogenated organic compounds. Discussion of the advantages and disadvantages of implementing this system over more conventional methods will follow. Finally, this section will conclude with a short evaluation of the potential for application of the technology to the FS-12 site. For additional details about the reactive wall and implementing innovative technologies at Superfund sites, see Appendix D.

**3.2.3.2.1 Background Information**

The permeable reactive wall, a promising innovative technology, provides a remedial alternative to common groundwater contamination cleanup efforts. Developed by Dr. Robert Gillham of the University of Waterloo (CANADA), this technology provides flexibility in its implementation and application to treating groundwater contamination.

The reactive media acts on the plume as the groundwater flow carries the contaminated water through the wall (see Figure 16). The wall can be applied to enhance biodegradation, reduce harmful contaminants, or precipitate out metals in groundwater. Its versatility extends to its implementation as either an *in situ* or *ex situ* treatment. Specifically for the purposes of this group project, its degradation capability has been expanded to a number of halogenated organic contaminants, including tetrachloroethene (PCE) and trichloroethene (TCE), through a reductive dehalogenation using zero valent iron. But of more importance to the FS-12 plume, this technology has readily degraded ethyl dibromide, a contaminant of concern at this site.

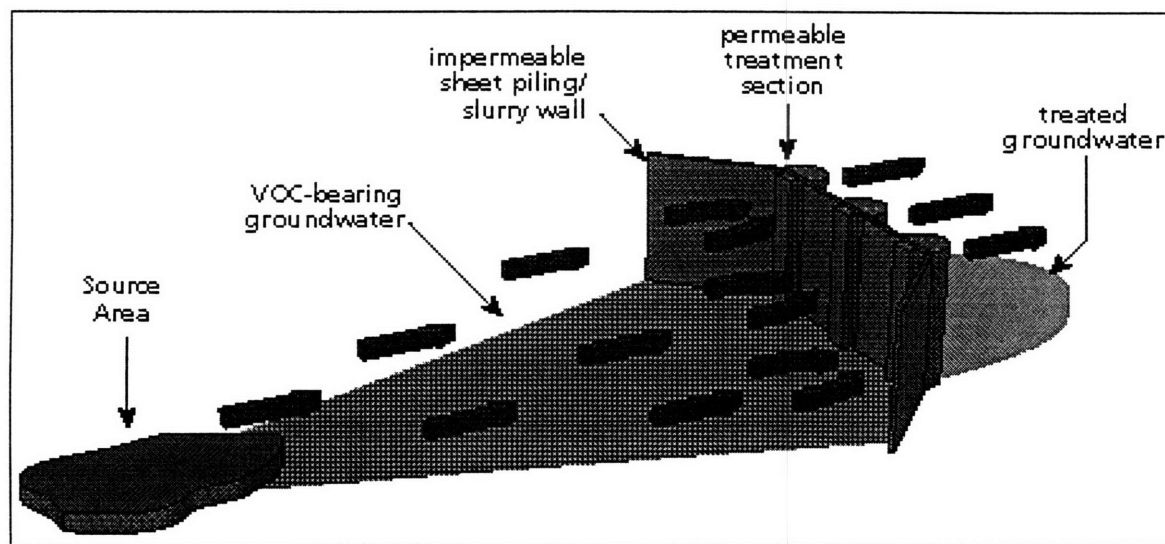

(<http://www.beak.com/eti.html>)

**Figure 18 - Permeable Reactive Wall Used in Conjunction with Funneling Barriers**

#### 3.2.3.2.2 Process Description

The chemical pathways involved with the degradation of these halogenated organic contaminants by the zero valent iron is still unclear. Gillham and O'Hannesin (1992) have concluded that the reaction is abiotic (independent of biological breakdown) and involves reductive dehalogenation of the contaminant. Gillham and O'Hannesin (1994) believe that there are two reductive reaction series that could be occurring in the wall—one that requires the hydrolysis of water and one that does not. Current thinking is

that the series of reactions does not in fact, require hydrolysis to occur, resulting a single step reaction process (Gillham and O'Hannesin, 1994).

In terms of the rate of reaction, studies have found that this reaction exhibits a first order rate constant (Helland et al., 1995). However, a number of factors could influence the speed of degradation of the halogenated organic contaminants. In field tests, lower groundwater and field temperatures have been noted to decrease reaction rates. With decreasing temperatures, the impact on reaction rates are greater for more chlorinated and halogenated contaminants (Personal Communication with John Vogan). pH, on the other hand, has not exhibited a direct affect on the reaction rate (Personal Communication with John Vogan). However, studies have noted that pH levels above 9.5 may cause an indirect decrease in reaction rate due to precipitation resulting in coating of the reactive surface or clogging of the pore spaces in the wall (Gillham et al., 1993). As for degradation of VOCs, this technology appears rather "robust" in that "stabilizing agents commonly added to industrial solvents or by inorganic groundwater chemistry" do not affect the reaction rate (Vogan et al., 1995).

#### 3.2.3.2.3 Implementation and Design

Designing an effective wall requires careful consideration of a number of factors. These include the hydrogeologic characteristics of the site and plume, contaminant levels in the groundwater, and MCL goal following treatment. These factors affect the selection of the implementation site, the ratio of iron to sand in the reactive media, and the width and thickness of the wall.

A key concern for implementing this technology is selecting a site through which the entire plume will pass through for treatment. This relies on a clear model and understanding of the site characteristics and plume movement--information not always readily available. Site selection also requires finding an implementation point that is not too deep to insert the wall and funneling barriers. Funneling barriers, walls of low conductivity (ex: slurry walls, sheet pilings), are sometimes constructed to direct flow to minimize the required width of the reactive wall. For further details about various configurations, see Appendix D.

The width of the wall is also a concern in the design process. To compete with conventional methods, such as pump-and-treat, the design must be effective and efficient. Iron filings and implementation costs can be cost prohibitive at times. Iron filings cost at a minimum of \$400 per ton (Personal Communication with John Vogan). But, new findings show that this concern may become inconsequential, as recycling of iron wastes from foundry and mining operation can be used with minimal effect on the reaction rate. Implementation costs are dependent on the equipment and method chosen, the depth required for entrance, and the geological characteristics of the site. The reaction process itself, in the case of PCE and TCE, has produced low levels of toxic chlorinated products such as dichloroethene and vinyl chloride. Thus, an appropriate residence time is required within the wall to ensure complete degradation. This requires an appropriate thickness of the wall.

The relative thickness of the wall can be balanced by the ratio of the reactive zero valent iron to sand. The percentages can range depending on the contaminant levels and the MCL allowed following treatment. As a design rule of thumb, if the levels of contaminants are at the parts per million level, 100% zero valent iron is used for the reactive media. For lower levels of halogenated organic compounds, a balance must be struck between reactive surface area of the iron and the sand and the hydraulic conductivity of the wall. (Personal Communication with John Vogan)

In selecting a remedial technology, the site manager desires an effective and efficient solution to the groundwater contamination at the site. The reactive wall technology requires a high initial capital investment, but minimal operation and maintenance cost as a result of its passive nature. In comparison to the conventional method of pump-and-treat, the wall provides a more cost effective treatment. Furthermore, the reduction reaction series of the wall (given a sufficient residence time) degrades the contaminant rather than transfers the contaminant to a different media; such as activated carbon. There is uncertainty over the duration that the zero valent iron is able to sustain effectiveness. Gillham predicts that the iron will be effective for at least ten years (Personal Communication with Robert Gillham). However in comparison to pump-and-treat, this technology is not anymore time efficient in its required cleanup time, since it relies on the groundwater flow to bring the contaminated water to the wall.

As the capabilities of the wall develop, its versatility can be applied during the design of a system. As varying elements are used for degradation and precipitation of contaminants, as well as enhancement of biodegradation, a system of walls, placed in series can degrade a range of contaminants. The reactive walls can also be part of a treatment train--one in a series of technologies used together to remediate arrange of contaminants in groundwater. When complemented with funneling barriers, walls can also be implemented in parallel such that a larger plume width can be efficiently treated. This system configuration is popularly named the "funnel-and-gate."

#### 3.2.3.2.4 Application at FS-12

The two contaminants of concern at the FS-12 site are benzene and EDB. EnviroMetal Technologies, Inc. have found the reactive wall to successfully degrade EDB. Thus far, Gillham found that the zero valent iron is not able to degrade BTEX, which includes benzene, without significant changes, such as metal enhancement of the iron (Personal Communication with Robert Gillham). However, the plumes of these contaminants plunge to a depth over 100 ft near the source area. Application of this technology to FS-12 is possible, if the plume resurfaces near the shore of a surface water body. Using the model formulated in section 3.1, the plume does not enter Snake Pond. Thus, application of this technology is not possible at the FS-12 site.

### **3.3 Water Supply Issues**

The Plume Response Plan states that one of the major objectives of the remediation scheme is "to reduce the risks to human health associated with the potential consumption of water." In addition, various reports have quoted that the groundwater contamination may cause a potential shortage of water in the Upper Cape Water Districts (Falmouth, Bourne, Sandwich, Mashpee). The goal of this section is to assess the current and future water situation and determine if the proposed remediation program is effectively addressing water supply issues. Public acceptance issues surrounding the use of treated groundwater are also assessed.

### **3.3.1 Current Water Situation In The Upper Cape Water Districts**

#### **3.3.1.1 Water Uses**

Customers using the public water supply system are the primary water users on Upper Cape Cod, with an off-season average demand of 6.9 million gallons per day (mgd) and an in-season (June, July, August) average demand of 14.3 mgd. Depending on the water district, 50% (Mashpee, Bourne) to 90% (Falmouth) of the population is on a central water supply. The remainder is self-supplied, relying entirely on individual private wells. Groundwater is the source of all public water supplies, with the exception of the town of Falmouth which is partly supplied by a surface water source, Long Pond Reservoir. Estimated water needs by industrial and commercial users is 0.9 mgd. Registered cranberry growers on Upper Cape Cod use more than 5.4 mgd (Department of Environmental Management, 1994).

#### **3.3.1.2 Water Resources**

The maximum pumping capacity (or sustainable yield) for the four water districts was estimated at 40.4 mgd. The current in-season pumpage is 9.6 mgd, and is expected to rise to 14.5 mgd in 2020 (Department of Environmental Management, 1994). Assuming that 20% of the Upper Cape water resources would be lost due to further migration of the plumes in the case of the do nothing alternative, the pumping capacity would be decreased to 32.3 mgd. In-season use in 2020 would then equal 45% of total water resources. According to these strict calculations, water shortages will not occur as a result of contamination from the MMR. However, other considerations such as land availability and the high cost of drilling new wells may make treating the water feasible and/or necessary.

#### **3.3.1.3 Water Quality**

To date, five public wells have been taken off line due to the contamination from the MMR plumes:



- Falmouth Water District: Ashumet Valley and Coonamessett Pond wells
- Bourne Water District: Wells # 2 and 5 (although they may be used on-season)
- Sandwich Water District: Weeks Pond well (for precautionary purposes only)

In addition to the threat posed by the MMR plumes, the aquifer is susceptible to contamination from septic wastes, municipal sewage systems, and fertilizer leachates. This is due to the highly permeable nature of Upper Cape Cod soils. In addition, data has shown that clean water at the well can be contaminated within the distribution system:

- anaerobic bacterial growth in stagnation areas, notably dead ends
- TCE contamination due to pipe lining (PVC). Falmouth reported TCE levels exceeding MCLs by a factor of eight (38 ppb vs. 5 ppb)
- chlorine residuals in the distribution system. This issue could be solved if water would be treated, allowing chlorination rates to be significantly reduced.

With the exception of Falmouth where water is chlorinated, the water in all districts is neither treated nor disinfected. Almost everywhere potassium hydroxide is used to reduce pH. In Falmouth, it has been estimated that 60% of the water users have installed home treatment devices (Personal communication with Upper Cape Water District Superintendents).

#### ***3.3.1.4 Future Water Demand In The Upper Cape Water Districts***

Due to population growth, average water needs are expected to grow from 7.5 mgd in 1995 to 11.5 mgd in 2020 (+ 1.7 % per year) (Department of Environmental Management, 1994). All water districts, except Falmouth, should be able to meet the demand until at least 2020, provided alternative water supplies are developed to substitute wells lost due to plume migration. This point will be discussed further in the next section.

### **3.3.2 Impact Of Do nothing Alternative On Water Supply**

#### ***3.3.2.1 Alternative Water Supplies***

In order to reduce human health risks to an acceptable level, public and private wells already contaminated or directly threatened by further plume migration should be replaced. The following alternatives could be considered:

- wellhead treatment
- drilling new wells in pristine water areas
- monitoring private wells and/or connecting self-supplied households to the municipal distribution system
- water conservation programs and incentives.

Selection of the first alternative would depend on public acceptance. From interviews conducted with the Water District Superintendents, people currently supplied from pristine water sources would be the least likely to accept treatment (e.g. Bourne), whereas Falmouth residents, whose water is already chlorinated, would probably accept this alternative provided adequate (see Appendix E for further details). The acceptance rate would certainly be greatly increased if this alternative was proposed by the local water districts and not the MMR, due to the history of poor relationships between the MMR and the surrounding towns (Personal Communication with Upper Cape Water District Superintendents).

Selection of the second alternative would depend on land availability. This is an important problem on the Cape due to extensive real estate developments and the economic inability of most towns to reserve land for water supplies.

#### ***BOURNE***

In order to replace the public wells lost due to the LF-1 plume, the town of Bourne will drill a new well in the northwestern corner of the MMR and connect it to the main water carrier. Bourne is also considering the construction of transmission lines to put self-supplied properties on municipal water, notably in the Scraggy Neck residential

area, should the LF-1 plume migrate further (Personal Communication with Ralph Marks).

#### *FALMOUTH*

The recent shutdown of the Coonamessett well (contaminated by CS-4 EDB plume) has put additional strain on the town's water supply. Falmouth is considering reopening it after the installation of a well head treatment plant. In the meantime, the town's water district will implement voluntary restriction programs in order to face the increased on-season demand. Further migration of the Ashumet Valley and CS-4 plume would not endanger additional public water supplies. Private wells are not likely to be contaminated because they are shallow. However, close monitoring would be required. Self-supplied households would be switched to municipal water if risk levels are exceeded. (Personal Communication with Raymond Jack)

#### *SANDWICH*

Although the Weeks Pond well has been taken off line for precautionary reasons, further migration of the FS-12 plume is not expected to contaminate the pond, nor any other public water supplies. If needed, private wells could be connected to public water systems in the threatened areas. (Personal Communication with Robert Kreykenbohm)

#### *MASHPEE*

There is no public supply well in the potential contamination path in Mashpee. However, close monitoring of private wells would be required. Self-supplied households should be switched to municipal water if risk levels are exceeded. (Personal Communication with David Rich)

### **3.3.2.2 Investments And Costs Required**

Based on information provided by the Water District Superintendents, the following cost estimates have been obtained:

New 700 gpm well,

including land purchase, drilling and equipment	\$1.5-2.0 million
Well head treatment plant	\$0.7 million
Transmission line (16 inch diameter) (per ft)	\$250
Connecting Scraggy Neck residential area to public distribution system (100 properties)	\$1.0 million

Therefore, in the case of the no-action alternative, the cost of replacing contaminated or threatened water supplies (and thus substantially reducing human health risks) would be approximately:

- \$5 million for public wells substitution
- \$10-15 million to put all concerned self-supplied properties on public water supply

The total cost of \$10-15 million needs to be compared with the cost of remedial actions.

### **3.3.3 Impact On Water Supply After Remediation**

#### **3.3.3.1 Avoided Investments And Costs**

##### *Public Wells*

Because all threatened public wells will be replaced (or equipped with well head treatment plants), even in the case of the remediation/plume containment alternative, the avoided costs will not be significant.

##### *Private Wells*

Plume containment will preserve pristine groundwater sources. Thus, investments related to the construction of transmission lines to replace potentially threatened private wells will be avoided. However, in the worst case scenario (maximum probable plume migration, all private wells contaminated), the avoided costs would amount to less than \$10 million. This figure needs to be compared with the cost of remedial actions.

### 3.3.3.2 Feasibility Of Beneficial Use Of Treated Plume Water

Reuse of treated plume groundwater has been considered for potential beneficial reuse (drinking or irrigation water). Issues related to the public acceptance of this alternative will be analyzed in Section 3.3.4. Based on three demand scenarios, extraction wells pumping rates and transmission lines investment costs, an assessment of the water re injected/water extracted ratio and the water costs has been performed (Table 3) (Operational Technologies Corp., 1995)

**Table 3 - An Assessment of Water Re injection/Extraction Ratios and Water Costs**

Scenario	Demand (mgd)	Reinjected (total pumping rate 16 mgd)	Reinjected (total pumping rate 27 mgd)	Water reuse cost (\$/1000gal)	Current avg water price in 4 towns (\$/1000gal)
1	0.95	94 %	96 %	1.79 - 3.84	2.07 - 2.45
2	3.90	76 %	86 %	0.19 - 0.41	? (private wells)
3	4.85	70 %	82 %		

Scenario 1: domestic reuse (drinking water)

Scenario 2: recreational/agricultural reuse (irrigation of cranberry bogs and golf courses)

Scenario 3: combination of scenarios 1 and 2

Based on this analysis, three comments can be made:

- For almost all scenarios, reinjection rates are higher than the rate commonly cited as the acceptable minimum (75%). However, further investigation would be needed to ensure that a partial reinjection will not jeopardize the aquifer water balance.
- Treated water costs include conveyance costs only. Treatment cost is not considered.
- The cost of treated groundwater should be compared to the marginal cost of developing additional water supplies (replacing the wells lost due to contamination).

### **3.3.4 Public Perception of Drinking Treated Groundwater from MMR**

Under the MMR's Installation Restoration Program (IRP), a design is currently underway to contain the leading edges of the plumes emanating from the base. The proposed plan includes extraction of contaminated groundwater, treatment to remove contaminants to MCLs regulated by law, and subsequent subsurface discharge of the water. This program is funded by the Department of Defense (DOD) within its Defense Environmental Restoration Account (DERA). The DOD requires all programs funded by this account to assess other beneficial reuse options besides subsurface discharge for the extracted water. (Operational Technologies Corp., 1995) Beneficial reuse options include surface discharge to ponds, irrigation and agricultural use, and municipal use as a potable water source.

To fulfill this requirement, the Senior Management Board (SMB), the tasking body of the IRP, requested their design consultant, Operational Technologies, to review the beneficial reuse options according to effectiveness, feasibility, and cost. In addition, the SMB also requested that the Long Range Water Supply Process Action Team (LRWS PAT) and the Program Implementation Team (Team 2) conduct discussions concerning reuse options and present their opinions to the SMB. These two teams are comprised of the Water District Superintendents from the four towns surrounding the MMR (Falmouth, Bourne, Sandwich, and Mashpee), local residents, representatives from local groups, and the Cape Cod Commission.

It is this second task which is the focus of this study. The recommendation made by the teams to the SMB included 100% reinjection of the treated water to the aquifer. The main reason behind this recommendation was the lack of public acceptance to drinking treated groundwater. Little of the conversation focused on the other two beneficial reuse options, recharge to ponds and irrigation. The focus of this study was to more clearly define the reasons behind this public sentiment by conducting interviews with the members of the teams. This issue could become a very important one for the surrounding water districts of Falmouth, Bourne, Sandwich, and Mashpee as more of their water supplies are affected by the contamination emanating from the base. The LRWS PAT, made up of the four water district superintendents, is tasked with ensuring that those four water districts have sufficient supplies to meet demands until the year 2020. Currently, they are predicting a shortfall, most drastically in Falmouth

and Bourne. (LRWS PAT, 1994) Falmouth has lost several of its wells to contamination, the Ashumet Valley well in 1979 and the Coonamessett well in February 1996; and Bourne has lost Wells #2 & #5. With the potential for additional well contamination the towns have begun to search for new sites on which to drill wells. The issue becomes complicated as new sources of water become more difficult to establish due to lack of land availability and well construction and land costs. Thus, the use of treated water may need to be considered by these water districts, whether it is treatment of the water from their own contaminated wells, or treated water from the MMR. Consequently, this study assessed the reasons behind the lack of public acceptance of drinking treated groundwater from the MMR by conducting interviews with the members of the LRWS PAT and Team 2 Committees. For more discussion concerning these interviews, see Appendix E.

#### *Interviews*

The interviews were informally conducted in person or by telephone. Each individual was asked the following question: What are the main reasons behind this lack of public acceptance to drinking treated groundwater from the MMR? The following four reasons were the most prevalent:

- ***The perception that Cape Cod water is “pristine”.***

This belief in the pristineness of their water supply is evidenced in their absence of water treatment. Bourne, Sandwich, and Mashpee only control the pH of the water; they do not even disinfect the water through chlorination. The communities also believe that their water contains zero levels of contaminants. This belief is actually incorrect. For example, although the water being pumped from the aquifer might be “clean”, the pipes of the distribution system are leaching PCE, TCE, and other chemicals into their water at detectable levels below the MCLs (Personal Communications with Raymond Jack and Ralph Marks). Lastly, this belief is upheld in their perception that the water which would be available from the MMR would be treated, previously contaminated water. In a

community which believes treatment and contamination are unacceptable, it would be difficult to convince them to drink treated water from the MMR.

- ***The MMR cannot guarantee the water will reach non-detect (ND) levels of contaminants.***

Connected with their idea that their current water is pristine, the communities would accept nothing less than ND levels of contaminants in the water. The MMR, with its planned treatment facility, can technologically reach these levels. However, under its agreement with the DOD it cannot legally guarantee these levels. Therefore, the community sees this water as “cleaner, polluted water” (Public Meeting Participant).

- ***There exists an adversarial relationship between the MMR and the surrounding communities.***

The local residents have little faith in the MMR's convictions. They have been waiting for 17 years for a solution to emerge . . . and they are still waiting (Personal Communication with Raymond Jack).

- ***The public would prefer that the water district managers continue to search for new locations to drill water supply wells as long as this option remains viable.***

Bourne is currently searching for new well sites on MMR property.

As evidenced by these interviews, the lack of public acceptance is multi-faceted. There are technological, political, and social aspects which combine to create these public perceptions.



### *Outlook to the Future*

As part of the final recommendation the teams made to the SMB, they suggested that if water reuse is considered in the future, public education programs would need to be implemented in order to increase the public acceptance of drinking treated groundwater. Currently, the only water district manager who was and still is willing to use treated water from contaminated sources is Raymond Jack of Falmouth. In his interview, he pointed out that Falmouth is already using treated water from a local surface water body, Long Pond. This water, although not from a contaminated site, is treated with chlorine for disinfection purposes. In the future, as demand continues to grow over supply, land and well costs increase, and availability of land for new wells decreases, using treated water may become an option. Falmouth would be most receptive to the idea. Therefore, assessing the reasons behind the public's perception of the idea is a very important one in order to design appropriate educational programs for the future. For further details about educational programs, see Appendix E.

### **3.4 Cost-Benefit Analysis**

Under Superfund, the EPA is responsible for placing the most serious hazardous waste sites on the National Priorities List (NPL) through the Hazard Ranking System. By law, EPA is required to choose a cleanup strategy that protects the health of people living near each site regardless of cost. Superfund requires EPA to choose a cleanup strategy that is "cost-effective", but will also result in a "permanent and significant decrease" in the volume, toxicity, and mobility of contaminants. Therefore, EPA may consider most benefits, but must not be influenced by cost or an economic impact analysis. In light of the high costs and uncertainties relative to the technical feasibility of cleaning contaminated groundwater, questions have been raised about the benefit of the cleanup program. (Resources for the Future, 1995)

This chapter addresses the following questions. Is it beneficial to society to enforce stringent cleanup goals at all costs? What are the resulting costs and benefits if the aquifer is allowed to clean itself through natural processes? How does it compare with remedial schemes?

In order to address these questions, this chapter is comprised of three parts:

- definition of the evaluation process and determination of the parameters for the cost-effectiveness and cost/benefit analyses
- application of the methodology to the entire MMR Superfund site
- detailed analysis of the case study at FS-12

Due to the limited scope of this study and the uncertainties in the assumptions made, the results presented below should be considered with caution. Estimates are preliminary and are only intended to illustrate a methodology. However, the magnitude of the cost and benefits is of primary importance.

### **3.4.1 Cost-Benefit Analysis: General Issues And Methodology**

One of the indispensable tools used in remediation programs is environmental analysis which examines how actions affect the physical environment. Economic analysis provides a different perspective by analyzing the monetary effects of programs. The most ambitious of the techniques to value the benefits from environmental improvement is cost-benefit analysis. Though it makes the most precise statements about which policy choices are efficient, it also imposes the largest requirement for information in order to provide those statements. It is fairly easy for most people to accept the general premise that costs and benefits of actions should be weighed prior to deciding on a policy choice. The technique becomes more controversial, however, when specific numbers are attached to the anticipated benefits and costs and specific rules for translating these numbers into a decision are followed.

The following steps have been taken:

- definition of the proposed remedial actions (objectives, alternatives, impacts)
- establishment of the baseline/do nothing alternative

- assessment of the costs of remedial actions
- identification and estimation of the types of benefits
- evaluation of costs and benefits

### **3.4.2 Cost-Benefit Analysis: The MMR Superfund Site**

This section only addresses cost-benefit analysis. No cost-effectiveness has been performed. Hence, it has been assumed that the remediation scheme proposed by the IRP was cost-effective and could be included as such in the baseline. However, this assumption is questionable because alternative innovative remediation technologies may be more cost-effective than the pump and treat system selected by the IRP.

#### **3.4.2.1 Baseline Definition And Remedial Actions Considered**

The no action alternative was established as the baseline. The remediation alternatives considered were:

- no action with water supply replacement (both contaminated and threatened public and private wells)  
*Estimated cost: \$15 million*
- plume containment (seven plumes as proposed by the IRP)  
*Estimated cost: \$250 million (the \$100 million spent to date are not taken into account)*  
*Costs and benefits were assumed to accrue over the period 1995-2020 (25 years), and the discount rate was set at 5%.*

#### **3.4.2.2 Identification And Estimation Of The Types Of Benefits**

This section presents findings about the different types of benefits: commodity/resource, direct/indirect, and primary/secondary (see appendix F for more details).

##### **3.4.2.2.1 Direct Primary Benefits**

### Water Supply

As shown in Section 3.3.3.1, avoided costs (compared to no action alternative) due to the plume containment alternative would be \$10 million.

#### 3.4.2.2.2 Indirect Primary Benefits

##### Health Risks

The risk valuation method has been selected to assess the health costs to society. Using a conservative scenario, it was assumed the population supplied from public or private wells that are already or potentially contaminated by the plume would be exposed for 25 years to the risk level defined as “probable” in the MMR Risk Assessment studies. In other words, the population would use water contaminated to the average levels found in the plume. Even in the case of this conservative scenario, the number of additional cancers developed in the entire area over 25 years would amount to 15, over 80% due to EDB present in the FS-12 plume (See Figure 19).

**Figure 19 - No Action Alternative- Number of Additional Cancers Developed Over the Next 25 Years**

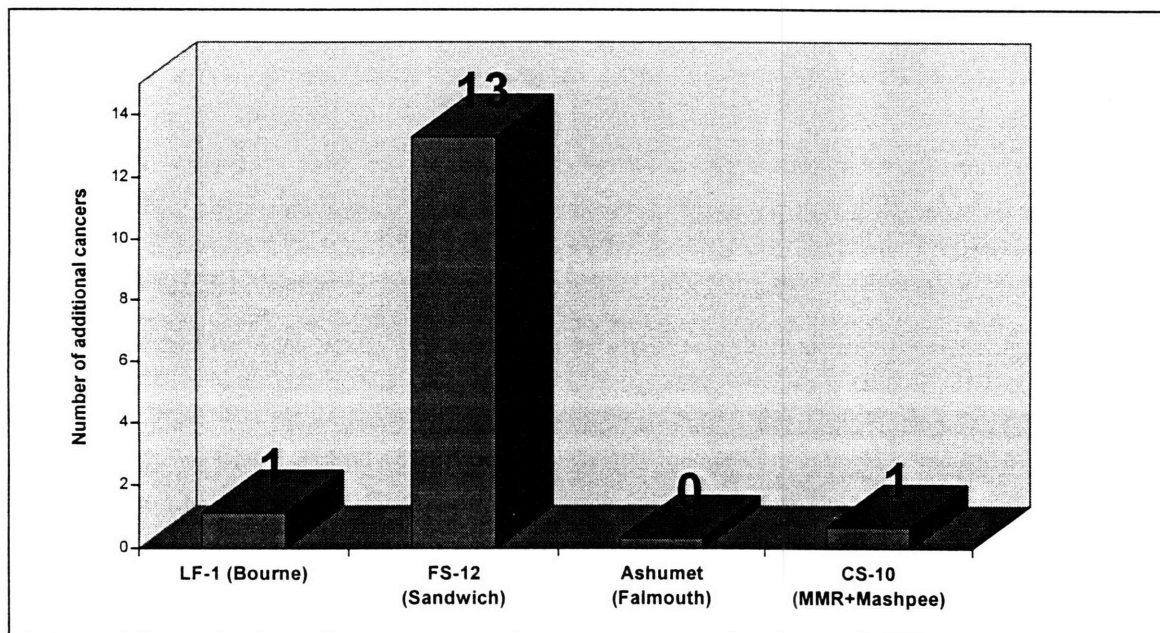

*Assumptions: Probable risk. Public and private wells contaminated to plume concentration levels, exposed population supplied from contaminated wells*

The resulting cost to society would be \$13 million. The number of cancers is surprisingly low, even in this worst case scenario: the exposed population is small, (approximately 5000 residents). For further details about costs and exposed population, see Appendix F.

Health risks could be essentially eliminated if the contaminated water supplies would be replaced as shown in section 3.3.3. Therefore, avoided costs due to water supply substitution would amount to \$13 million. Additional benefits generated by the plume containment alternative would not be significant.

### *Ecological Risk*

Valuation of ecological impacts is difficult because of the absence of quantitative studies. Contamination pathways have been analyzed only qualitatively. In addition, ecological risk was based on current plume concentrations; hence attenuation processes were neglected and figures are likely to be overstated. Concerns have also been raised about the impact on the ponds' water levels due to the pump and treat system. The planned extraction rates (27 mgd) may have a significant impact on the overall aquifer balance. As mentioned in section 2.1.1, the specialized and rare ecosystem that develops on the shores of these ponds is highly sensitive to water level changes. The containment plan itself has significant ecological risks that need to be weighed against the risks of taking no action. Because of the many unknown variables associated with the long-term operation of the containment system, it will be assumed that its ecological risks equal the risks associated with the do nothing alternative. Therefore, ecological risks have been removed from the cost-benefit comparison.

### *Property Value*

In towns, cities, and neighborhoods nationwide, scientific and statistical studies have documented that proximity to hazardous waste sites decreases property value. This negative impact of "perceived risk" has been shown in real estate markets around the MMR. Figures ranging from 5 to 15% in value reduction (real estate professionals). In this study, it has been conservatively assumed that all properties located less than a mile from an existing or future plume would experience a decrease of 10% in their value.

Valuation techniques such as hedonic pricing would provide more accurate results. These results are shown in Figure 20.

**Figure 20 - Loss on Property Values Due to MMR Contamination (\$ million)**

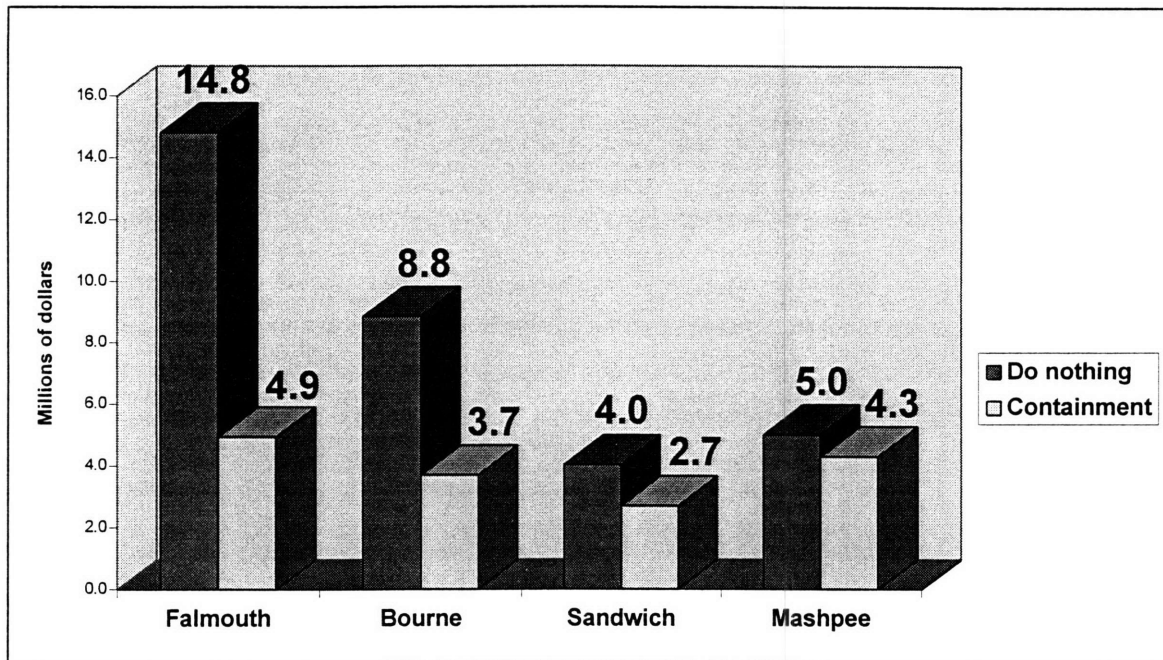

*Assumption: 10% reduction in the value of all property located less than a mile from a plume*

In the case of the plume containment alternative, the total loss in all four towns would be \$16 million (properties already affected by the plumes). In case of the no action alternative, this figure would rise to \$33 million due to the expansion of the contaminated area. Therefore, the avoided cost due to plume containment would be \$17 million.

All primary benefits identified are summarized in Figure 21. If only primary benefits are considered, the total of \$40 million would not justify the expenses incurred in the case of the plume containment alternative.

**Figure 21 - Primary Benefits Accruing Over 1995-2020 (\$ million, cumulative)**

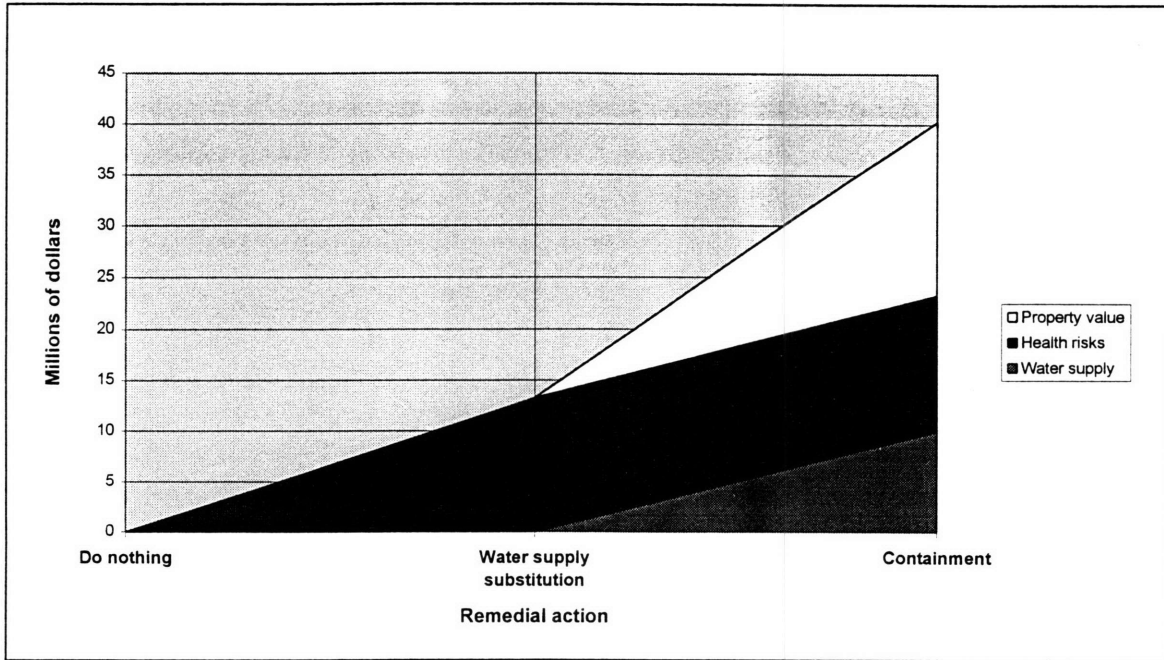

### 3.4.2.2.3 Secondary Benefits

#### *Economy*

The psychological impact of the MMR groundwater contamination on the local economy and tourism is difficult to quantify and measure. Nonetheless, it is important to consider it in evaluating any remediation alternative. In 1994, the economy base was estimated at \$610 million for the Upper Cape area (Cape Cod Commission, 1996) (see Figure 22).

**Figure 22 - Upper Cape Economic Base (Total \$610 million, 1992)**

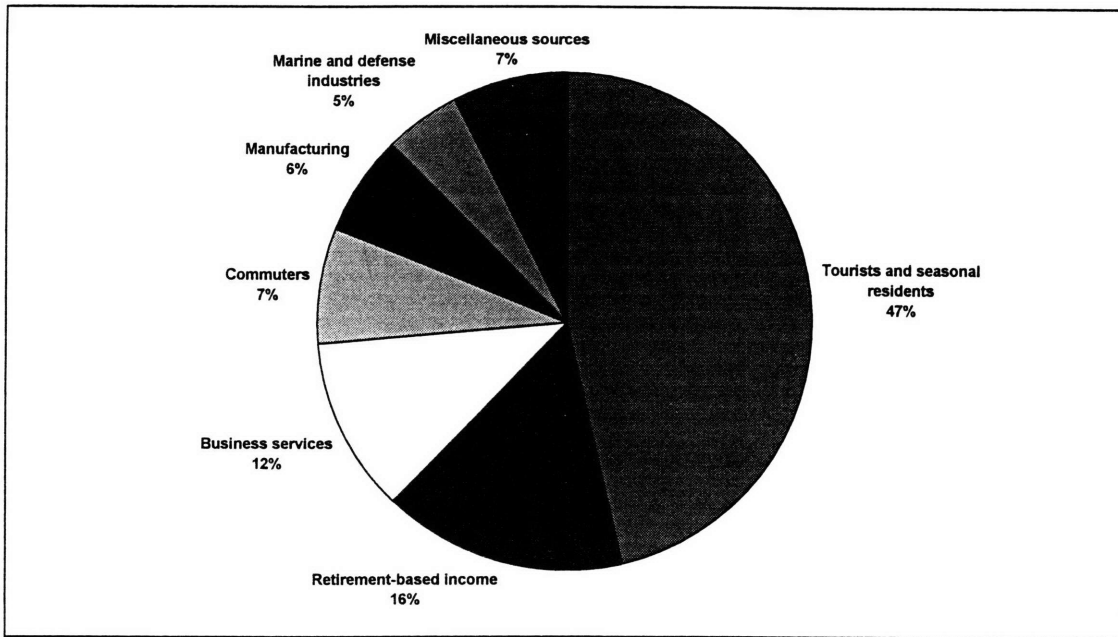

More than 80% of the economic base can be considered highly sensitive to perceived risk of groundwater contamination (tourism, retirement-based income, business, commuters). In the absence of any study documenting the impact of the MMR contamination on the local economy, an analysis was conducted to determine the sensitivity of the economic base to the variation in growth rate. As opposed to the no-action alternative, the assumption that, any level of remediation would provide a strong positive signal to the local economy because public confidence would be restored. If there were no contamination problems, the Upper Cape economy is assumed to grow at a constant yearly rate of 3% over the period 1995-2020. An examination of the impact on the economic base of any decrease in the growth rate be due to the perceived risk (e.g. smaller number of tourists than expected) follows.

**Table 4 - Impact of Perceived Risk on Economic Base**

Yearly Growth	3.0 %	2.9 %	2.8 %	2.7 %	2.6 %	2.5 %
Economic base decrease (\$ million)*	0	-119	-236	-351	-463	-572



\* net present value (I = 5 %, n = 25 years)

Assuming that the growth rate would decrease from 3.0 to 2.8% as a result of the no action alternative, the cost to the local economy over 25 years (in net present value terms) could be as high as \$236 million. This would justify the proposed cleanup actions. This rationale implies that cleanup operations would give the necessary positive signal to the local economy. However, one may question whether plume containment would be the most cost-effective means to restore public confidence and reduce the perceived risk.

*Resource Benefits*

Resource benefits (or non-use values) consist of option values (benefit of being able to use the water at some time in the future), bequest values (benefit of having a source of clean water for future generations), existence values (benefit of knowing that the water is uncontaminated, even if there is no expectation that it will have to be used), and recreation values. An EPA study determined that citizens will pay an average of \$7 per person per month for non-use values of groundwater. When added over the Upper Cape towns over 25 years, assuming that future Cape Cod residents would demonstrate the same willingness to pay, the resource benefits would amount to \$150 million.

**3.4.2.3 Costs versus Benefits**

Benefits and costs can be compared to obtain the net benefit (see Table 5).

**Table 5 - Discounted Costs and Benefits for the Period 1995-2020**

I = 5%, n=25 years	No Action (baseline)	Water Supplies Replacement	Plume Containment
<b>COSTS</b>	0	15	250
<b>BENEFITS</b>			
Water Supply	0	0	10
Health Risks	0	13	13
Property Value	0	0	17
Economic Base	0	0	0 to 250 ?

Non-Use Values	0	0	0 to 150 ?
NET BENEFIT	0	2	-210 to 190

The following comments can be made:

A) The water supply replacement alternative yields positive net benefits. However, this option does not answer equity issues. While net benefits are positive for society as a whole, they are negative for the Upper Cape area. This is due to the fact that economic and non-use negative impacts are not alleviated. Hence, a transfer of financial resources to the Upper Cape area should be considered. This transfer could take the form of a compensation package valued according to the economic cost of environmental damage. Among the possible uses of the compensation package, the following alternatives may be suggested:

- direct compensation paid to residents affected by the pollution
- creation of an investment fund for beneficial use by future generations
- purchase of land (e.g. MMR) for effective protection of groundwater resources
- elimination of septic tanks and other current pollution sources to protect groundwater

B) The remediation alternative would yield positive net benefits only if negative impacts on economic base and non-use values would exceed \$210 million. Further investigations would be required to confirm this figure. In addition, even if analyses demonstrate that this remediation alternative would yield positive net benefits, the optimal cleanup level may not be attained. Alternative technologies, cleanup goals or compensation options (such as those cited above) may prove more efficient.

### 3.4.3 Economic Analysis: A Case Study Of The Fuel Spill 12

This section provides a synthesis of the findings presented in section 3.2 from an economic perspective. The different remediation technologies are analyzed in terms of cost-effectiveness. Finally, using the methodology developed in Appendix F, several remediation alternatives are assessed in terms of costs and benefits.

### 3.4.3.1 Cost-Effectiveness Analysis

The goal of the cost-effectiveness analysis is to determine which treatment alternative meets the a set cleanup goal (i.e. contamination level decreased to MCLs) at the least cost. Three technologies have been considered in the present analysis: pump and treat, air sparging, and reactive wall. In addition, the natural attenuation alternative is used as a baseline (Table 6).

**Table 6 - Discounted Costs for the Period 1995-2020 (Interest Rate = 5 %)**

	Natural Attenuation	Natural Attenuation and Water Supply Replacement	Pump and Treat	Product Recovery and Air Sparging	Reactive Wall
Costs	0.6	1.6	5.0	2.0	na
Time to Reach MCLs (years)	> 10	> 10	15	**	na
Plume migration	yes	yes	no	yes (limited)	no
Human health risks	not acceptable	acceptable	acceptable	acceptable	acceptable

\*\* Air Sparging will not reach MCLs within the planned operation time (2 years) (see Appendix B)

If the goal of the MMR program is to reach MCLs and preserve pristine groundwater from contamination, the air sparging option would be the most cost-effective. However, due to the uncertainties related to the ability of this technology to reach MCLs, the pump and treat alternative may be more attractive. Natural attenuation combined with water supply replacement would be the most cost-effective alternative if further migration of the plume is not a determinant factor at FS-12.

### **3.4.3.2 Cost-Benefit Analysis**

The cost-benefit analysis answers the following question: how do incurred costs to reach cleanup levels compare with benefits?

#### 3.4.3.2.1 Primary Benefits

##### *Water Resources*

As shown in Section 3.3.4, avoided costs (compared to no action alternative) due to the plume containment alternative would be \$1 million.

##### *Human Health Risks*

Using a conservative scenario, it was assumed the population supplied from public or private wells that are already or potentially contaminated by the plume would be exposed for 25 years to the risk level defined as “probable” in the MMR Risk Assessment studies. In other words, the population would use a water contaminated to the average levels found in the plume. In the case of this conservative scenario, the number of additional cancers developed in the FS-12 area over 25 years would amount to 13 (Figure 19). Resulting costs to society would amount to \$11 million.

##### *Ecological Risk*

Section 3.2.1.3 suggests that impacts on the environment would be negligible. However, further investigation would be required to confirm this statement.

##### *Property Value*

Assuming that all properties located less than a mile from an existing or future plume would experience a decrease of 10% in their value, the loss would amount to \$4 million in the case of the do nothing alternative, and \$2.7 million if the plume is contained. Therefore, the plume containment would yield a benefit of \$1.3 million.

#### 3.4.3.2.2 Secondary Benefits

### *Economy*

The perceived risk due to unmitigated contamination could lead to a reduction of the growth rate in the area surrounding FS-12. Considering the high potential for development of the area, the impact may be significant, although difficult to presently quantify.

### *Resource Benefits*

Due to the fact that significant amounts of pristine groundwater could be contaminated in the case of the do nothing alternative, resource benefits associated with remediation, notably containment alternatives, could be important. Based on the assumptions made in Section 3.3, resource benefits could amount to \$10 million over the next 25 years.

#### 3.4.3.2.3 Costs versus Benefits

The high cancer risk and the uncertainties associated with the do nothing alternative would call for the implementation of remediation measures. Depending on the value placed on the groundwater potentially contaminated by further plume migration, plume containment alternatives may be more beneficial than source control alternatives.

## 4. Conclusions and Recommendations

The Massachusetts Military Reservation (MMR), located on Cape Cod, is listed on the National Priority List as a Superfund site. A variety of military activities have produced extensive contamination of the groundwater underlying the reservation. The nature of contaminants is varied and different for the nine plumes. This report focuses on a fuel spill, Fuel Spill 12 (FS-12), resulting from a leak in a pipeline which transports JP-4 fuel to the MMR.

FS-12 was used as a case study to assess the movement of a fuel contaminated plume; and to determine the efficacy of various remediation techniques on the contaminated groundwater. Within the alternatives for remediation two classes of option were suggested: source control, and leading edge containment. In addition, a study was conducted about regional water supply issues concerning alternate water supply and public perception of the alternatives.

The groundwater flow field was studied and modeled to determine the migration of the observed plume. The effects and possible hazards of the contaminants reaching the neighboring water bodies were also assessed using the model. Currently, soil vapor extraction and air sparging is being applied as a method for source remediation. However, it was further studied and analyzed to determine the appropriateness and applicability at FS-12. To determine the most efficient method to contain and control the migration of the leading hedge of contaminated groundwater, two techniques were analyzed: pump and treat of the contaminated water and the permeable reactive wall. To correctly evaluate the various remediation techniques the “do nothing” alternative was analyzed as the baseline for comparison. In light of the do nothing alternative, the possibility of alternative water supplies were also studied. A cost-benefit analysis was conducted for the entire MMR to determine and compare the value of remediating the site and of using alternative water supplies. In addition, the public perception of treated drinking water was surveyed and evaluated.

The extensive investigation produced various answers and insights regarding the different remediation alternatives, the possible alternatives for water supplies including the public perception. The results of this study are summarized below:

- The flow field is directed in a southeastern direction. The spreading and migration of the plume follows the groundwater flow. Thus the plume does not have any significant effects on Snake Pond. The simulation resulted in safe levels of contamination in the pond. In addition, it was determined that the plume, if left untreated, would eventually reach the other water bodies in the East, particularly Mashpee Pond. However, this does not pose any serious threat as the contaminants level would be very low, thus safe.
- Natural restoration (i.e. do nothing alternative) of the FS-12 site could be an attractive clean-up strategy given the high costs associated with active remediation of contaminants. Due to a lack of information, further investigations would be needed to quantitatively assess the consequences of this strategy.
- The air sparging/soil vapor extraction design for the remediation of the FS-12 source area was found to be highly effective. The number of wells and their radii of influence were determined to extend over a five acres area for an effective remediation of the source and corresponding free product. However, the time of required to reach the MCL level of 5 ppb, was determined to be 9 years as opposed to 2 years as suggested by the IRP study.
- The proposed method of containment is pump and treat. A pump and treat system consisting of an extraction well fence and granular activated carbon was found to be appropriate. The recommended design includes eleven extraction wells surrounding the toe of the plume and pumping at a rate of 800 gallon per minute.
- The reactive wall could not be used to degrade benzene. It was found, however, to be an excellent alternative for the remediation and control of EDB. In the final containment design the reactive wall could not be applied because of the extreme depth of the plume.
- One objective of the plume containment scheme is to will protect the Upper Cape water resources. However, only a very small fraction will be preserved by the

proposed plan. In addition, the scheme does not address the major constraint on future water supply expansion - the lack of accessibility to groundwater due to land development. In this respect, there is a clear need to protect groundwater resources by establishing zones of groundwater protection, and land acquisition near wellfields.

- The public perception and acceptability of drinking treated groundwater was investigated by interviewing members of the Long Range Water Supply Process Action Team and Team 2. The perception and acceptability of treated water by the public is very important for developing future water sources. Currently, the local residents are not willing to drink treated water from the MMR or from the treatment of existing wells. In the future, educational programs can be implemented to increase the public acceptance of this idea.
- One of the greatest myths about the current operation of the MMR remediation program is that remediation is justified by the need to protect people's health from consumption of contaminated groundwater. If this was the primary rationale for action, there are many feasible options short of treating contaminated groundwater, such as providing alternative water supplies that could protect public health. One should question the appropriateness of a \$250 million cleanup program in light of the fact that the same public health objectives could be met by replacing the contaminated water supplies at a cost of only \$10 million. One of the hidden yet worthy objectives of the program is to protect the quality of the Upper Cape's groundwater for future, yet unspecified uses by human and nonhuman species. Another underlying objective is driven by political and economic motivations: the reduction of perceived risk that may cause extensive damage to the Upper Cape's quality of life and economy. The question that policymakers need to address is how much society and taxpayers are willing to pay now to protect the cleanliness of groundwater supplies for unspecified future uses and the assurance of knowing that the groundwater is clean.



## REFERENCES

- Advanced Sciences, Inc. *Remedial Investigation Report, Remedial Investigation/Feasibility Study, FS-12 Study Area*. Installation Restoration Program, Massachusetts Military Reservation. Prepared for HAZWRAP, Oak Ridge, Tennessee. December 1993.
- Air National Guard. *Field Sampling and Analysis Plan for Groundwater Monitoring Program*. Massachusetts Military Reservation. June 1994.
- Baker, Ralph S., et al. *Evidence of Preferential Vapor Flow During In Situ Air Sparging*. In Situ Aeration: Air Sparging, Bioventing, and Related Remediation Processes. Columbus: Battelle Memorial Institute, 1995. pp. 63-73.
- Bosch, Christophe. *Massachusetts Military Reservation Superfund Site: Did Cost and Benefits Matter in Remediation Decisions?* M.Eng. Thesis. Massachusetts Institute of Technology, 1996.
- Borden, Robert C., et al. "Geochemical Indicators of Intrinsic Bioremediation." *Groundwater*, Vol. 33, No. 2, 1995.
- Cambareri, T. C., et al. "Benzene Transport Through a Mature Hydrocarbon Plume in a Sand and Gravel Aquifer." *Focus Conference on Eastern Regional Groundwater Issues*, Newton, MA. 1992.
- Camp, Dresser & McKee, Inc. *Dynflow, A 3-Dimensional Finite Element Groundwater Flow Model, Description and User's Manual, Version 3.0*. 1984.
- Camp, Dresser & McKee, Inc. *Dynsystem, Groundwater Flow And Transport Modeling System, Reference Guide*. 1992.
- Camp, Dresser & McKee, Inc. *Dyntrack, A 3-Dimensional Transport Model for Groundwater Studies, Description and User's Manual, Version 1.0*. 1984.
- Cape Cod Commission. *Cape Trends, Demographic and Economic Characteristics and Trends*. Barnstable County, 3rd edition. 1996.
- Chao, Keh-Ping and Say Kee Ong. *Air Sparging: Effects of VOCs and Soil Properties on VOC Volatilization*. In Situ Aeration: Air Sparging, Bioventing, and Related Remediation Processes. Columbus: Battelle Memorial Institute, 1995. pp. 103- 110.
- Clayton, Wilson S., et al. *Air Sparging and Bioremediation: The Case for In Situ Mixing*. In Situ Aeration: Air Sparging, Bioventing, and Related Remediation Processes. Columbus: Battelle Memorial Institute, 1995. pp. 75-85.
- Davis, Robert. "Correspondence." Cost Estimate for Furnishment, Installation, and Operation of a Combined Air Sparging/Soil Vapor Extraction System. Installation Restoration Program. 1995.
- Department of Environmental Management, Massachusetts Executive Office of Environmental Affairs. *Water Resources of Cape Cod*. October 1994.
- Domenico, P. A. and F. W. Schwartz. *Physical and Chemical Hydrogeology*. John Wiley & Sons, Inc., New York. 1990.

- Dupont, Dr. R. Ryan. "Fundamentals of Bioventing Applied to Fuel Contaminated Sites." *Environmental Progress*, Vol. 2, No. 1, 1993. pp. 45-52.
- Frank, U. and N. Barkley. "Remediation of Low Permeability Subsurface Formations By Fracturing Enhancement of Soil Vapor Extraction," *Journal of Hazardous Materials*, Vol. 40, 1995. pp. 191-201.
- Freeze, R. A. and J. A. Cherry. *Groundwater*. Prentice Hall, Inc., New Jersey, 1979.
- Gagnon, Judy. *The Public Perception of Drinking Treated Groundwater from the Massachusetts Military Reservation, Cape Cod, Massachusetts*. M.Eng. Thesis. Massachusetts Institute of Technology, 1996.
- Gelhar, L. W., C. Welty, and K. R. Rehfeldt. "A Critical Review of Data on Field-Scale Dispersion in Aquifers." *Water Resources Research*, Vol. 28, No. 7, July 1992. pp. 1955-1974.
- Gillham et al. "Metal Enhanced Abiotic Degradation of Halogenated Aliphatics: Laboratory Tests and Field Trials." *1993 HazMat Central Conference*. Chicago: March 9-11, 1993.
- Gillham, Robert and Stephanie O'Hannesin. "Enhanced Degradation of Halogenated Aliphatic by Zero-Valent Iron." *Groundwater*, Vol. 32, November/December 1994. pp. 958-967.
- Gillham, Robert and Stephanie O'Hannesin. "Metal-Catalyzed Abiotic Degradation of Halogenated Organic Compounds." *1992 IAHA/IIH Conference: Modern Trends in Hydrogeology*. Ontario: May 11-13, 1992. pp. 94-103.
- Goo, Holly. *Barriers to Demonstrating and Implementing Innovative Technologies at Hazardous Waste Sites: A Case Study of the Permeable Reactive Wall at the Massachusetts Military Reservation*. M.Eng. Thesis. Massachusetts Institute of Technology, 1996.
- Hazardous Waste Remedial Action Program. *Final Design Package for the FS-12 Product Recovery System*. Massachusetts Military Reservation. Prepared for the National Guard Bureau. July 1994.
- Helland et al. "Reductive Dechlorination of Carbon Tetrachloride with Elemental Iron." *Journal of Hazardous Materials*, Vol. 41, 1995. pp. 205-216.
- <http://www.terravac.com/TVtoolsas.html>. "Air Sparging (Sparge Vac)." Terra Vac.
- Hutchings, T. *Application of Modeling Techniques to Test Hypotheses Concerning the Migration of Aviation Gasoline from a Surface Spill*. M.S. Thesis, Dept. Of Civil and Environmental Engineering, Massachusetts Institute of Technology, 1995.
- HydroGeoLogic, Inc. *Aquifer Test Analysis, Massachusetts Military Reservation, Cape Cod, Massachusetts*. Hazardous Waste Remedial Action Program, Oak Ridge, Tennessee. June 1994.
- Installation Restoration Program. *Group Meeting Minutes - Long Range Water Supply/Team 2*. Massachusetts Military Reservation. July 13 & 18, 1995.
- Ji, Wei. *Air Sparging: Experimental and Theoretical Analysis of Flow and Numerical Modeling of Mass Transfer* Ph. D. Thesis, The University of Connecticut, 1994.

- LeBlanc, D. R., J. H. Guswa, M. H. Frimpter, and M. H. Londquist. *Ground-Water Resources of Cape Cod, Massachusetts*. Department of the Interior, U.S. Geological Survey Hydrologic Investigations, Atlas HA-692 (sheet 3 of 4), 1986.
- Loden, Mary E. *A Technology Assessment of Soil Vapor Extraction and Air Sparging*. EPA/600/R-92/173. September, 1992.
- Long Range Water Supply Process Action Team. *Draft Long Range Water Supply Strategy*. 1994.
- MacKay, D., W. Y. Shiu, and K. C. Ma. *Illustrated Handbook of Physical/Chemical Properties and Environmental Fate for Organic Chemicals, Vol. I, Monoaromatic Hydrocarbons, Chlorobenzenes and PCB's*. Lewis Publishers, 1992.
- Marley, Michael C., et al. "Air Sparging Technology: A Practice Update." *In Situ Aeration: Air Sparging, Bioventing, and Related Remediation Processes*. Columbus: Battelle Memorial Institute, 1995. pp. 21-37.
- Masterson, John P. and Paul M. Barlow. *Effects of Simulated Ground-Water Pumping and Recharge on Ground-Water Flow in Cape Cod, Martha's Vineyard, and Nantucket Island Basins, Massachusetts*. U.S. Geological Survey, Open-File Report 94-316, 1994.
- McCaulou, Douglas R., et al. "Evaluation of Vertical Circulation Wells For Enhanced Bioremediation." *In Situ Aeration: Air Sparging, Bioventing, and Related Remediation Processes*. Columbus: Battelle Memorial Institute, 1995. pp. 495-501.
- Member Agencies of the Federal Remediation Technologies Roundtable. *Remediation Case Studies: Groundwater Treatment*. EPA-542-R-95-003, March 1995.
- Mohr, Donald H. and Paul H. Merz. "Application of a 2D Air Flow Model to Soil Vapor Extraction and Bioventing Case Studies." *Groundwater*. Vol. 33, No. 34, 1995. pp. 33-444.
- Oldale, R. N. *Seismic Investigations on Cape Cod, Martha's Vineyard, and Nantucket, Massachusetts, and a Topographic Map of the Basement Surface from Cape Cod Bay to the Islands*. U.S. Geological Survey Prof. Paper 650-B, B122-B127, 1969.
- Operational Technologies Corporation. *Technical Memorandum for Beneficial Use of Treated Groundwater*. Massachusetts Military Reservation, Air National Guard, July 1995.
- Operational Technologies Corporation. *Plume Containment Design Analysis Plan, Evaluation of Alternatives*. Massachusetts Military Reservation, Air National Guard, 1996.
- Pankow, James F., et al. "Air Sparging in Gate Wells in Cutoff Walls and Trenches for Control of Plumes of Volatile Organic Compounds." *Ground Water*, Vol. 31, No. 4, 1993. pp. 654-662.
- Personal Communication with Robert Gillham. University of Waterloo. April 1996.
- Personal Communication with Robert Kreykenbohm. Sandwich Water District Superintendent. March 1996.
- Personal Communication with Thomas Cambareri. Water Resources Program Manager, Cape Cod Commission. March 1996.

- Personal Communication with Raymond Jack. Falmouth Water District Superintendent. March 1996.
- Personal Communication with Ralph Marks. Bourne Water District Superintendent. March 1996.
- Personal Communication with John Vogan. EnviroMetal Technologies, Inc. March 1996.
- Public Meeting Participant. Falmouth Town Meeting. February 1996.
- Resources for the Future. Analyzing Superfund, Economics, Science and Law. Washington DC, 1995.
- Riva, Vanessa. *Groundwater Modeling to Predict Plume Migration and to Design a Well Fence for a Fuel Spill at the Massachusetts Military Reservation*. M.Eng Thesis. Massachusetts Institute of Technology, 1996.
- Savoie, J. *Altitude and Configuration of the Water Table, Western Cape Cod Aquifer, Massachusetts, March 1993*. U.S. Department of the Interior, U.S. Geological Survey, Open-File Report 94-462, 1995.
- Schwarzenbach, R. P., P. M. Gschwend, and D. M. Imboden. Environmental Organic Chemistry. John Wiley & Sons, New York, 1993.
- Stone & Webster Environmental Technology & Services. *Final Record of Decision for Interim Action - Containment of Seven Groundwater Plumes*. 1995.
- Styliannou, Chrystalla and Bruce A. DeVantier. "Relative Air Permeability as Function of Saturation in Soil Venting." *Journal of Environmental Engineering*, Vol. 121, No. 4, 1995. pp. 337-346.
- Tietenberg Thomas. Environmental and Natural Resource Economics. Harper Collins, 1996.
- Triantopoulos, Dimitris. *Modeling of a Jet Fuel Spill in the Groundwater at the Massachusetts Military Reservation*. M.Eng. Thesis. Massachusetts Institute of Technology, 1996.
- U.S. Environmental Protection Agency. *A Guide for Cost-Effectiveness and Cost-Benefit Analysis of State and Local Groundwater Protection Programs*. Office of Water, Doc. No. 813-R-93-001, 1993.
- U.S. Environmental Protection Agency. *Methods for Measuring Non-Use Values: A Contingent Valuation Study of Groundwater Cleanup*. 1993.
- U. S. Geological Survey, Department of the Interior. *Cotuit Quadrangle, Massachusetts, N4132.5-W7022.5/7.5*. 1974.
- U.S. Environmental Protection Agency. *Superfund Innovative Technology Evaluation Program: Technology Profiles*. 7th Edition, EPA/540/R-94/526, Office of Research and Development. Cincinnati (Ohio), November 1994.
- Westinghouse Savannah River Company. *VOCs in Non-Arid Soils Technology Summary: Air Sparging/Vapor Extraction via Horizontal Wells*. Internet: 'VOCNA\_TOC.html'. Sect.3.1, p. 1.

Wilson, David J., et al. "Groundwater Cleanup by In-Situ Sparging. VIII. Effect of Air Channeling on Dissolved Volatile Organic Compounds Removal Efficiency." *Separation Science and Technology*, Vol. Z29, No. 18, 1994. pp. 2387-2418.