

**design | make**

the translation of design intention to fabrication

by

James R McLain, Jr

Bachelor of Architecture  
The University of Arizona, 2004

Submitted to the Department of Architecture  
In Partial Fulfillment of the Requirements for the Degree of

Master of Science

at the

Massachusetts Institute of Technology

September 2007

© 2007 James R McLain, Jr. All rights reserved.

The author hereby grants to MIT permission to reproduce and to distribute publicly paper and electronic copies of this thesis document in whole or in part in any medium now known or hereafter created.

Signature of Author.....

Department of Architecture  
10 August 2007

Certified by.....

Lawrence Sass  
Assistant Professor of Architecture  
Thesis Supervisor

Accepted by.....

Julian Beinart  
Professor of Architecture  
Chairman of the Department Committee on Graduate Students

## Committee

[thesis advisor]

Lawrence Sass, Assistant Professor  
Department of Architecture, MIT

[thesis reader]

Terry Knight, Professor  
Department of Architecture, MIT

**design | make** the translation of design intention to fabrication

by

James R McLain, Jr

Submitted to the Department of Architecture on August 10, 2007  
in partial fulfillment of the requirements for the Degree of Master of  
Science in the Department of Architecture.

[abstract]

The process of making innovative buildings is stifled by our current methodology of communicating design information. Advances in new techniques, technologies, methods, materials and knowledge for both designers and constructors have failed to successfully be implemented into the building industry because of our reliance on traditional methods of transmission and exchange.

The purpose of this thesis is to survey our current methods and propose an alternative process of communicating complex design information through a hypothetical design problem and subsequent physical fabrication. The objective of the research is to develop a process for designing, communicating and making of innovative parts / assemblies that will allow designers and fabricators to efficiently increase the quality of the products they produce.

Thesis Supervisor: Lawrence Sass  
Title: Assistant Professor of Architecture

## Acknowledgements

Like any ambitious effort, this work would not be possible without a great deal of assistance. Special thanks to...

### My Parents

for instilling work ethic and the value of education

### My Sister

for blazing a trail and setting the bar high

### Larry Sass

for his limitless enthusiasm and persuasion to push me further than I thought I could go

### Terry Knight

for her guidance, support, and introduction to new explorations

### Simon Kim & Tom Plewe

for their friendship, support, and Wednesday night BBB's

### Chris Trumble, John Folan & Alvaro Malo

for mentoring and encouraging me to pursue this endeavor

### Page Repp & Stacy Burnett

for their ideology and beliefs that laid the foundation for this investigation

### Luis Ibarra & Teresa Rosano

for their passion and rigor that is an inspiration

### Michael, Denyse, Colleen, Julianne & Danielle Turpin

for making me feel at home and keeping me grounded

and above all

### Brandy

my wife, for her endless support, love, encouragement, patients, friendship, and advice who without her, none of this would have been possible.

Title page

Committee

Abstract

Acknowledgements

Contents

07 1.0 Introduction

    1.1 Motivation

    1.2 Research Objective + Outline

    1.3 Importance of Research

    1.4 Uniqueness of Study

    1.5 Past Research

10 2.0 Background & Purpose

    2.1 Process: History of the Designer and Constructor Relationship

    2.2 Making: Idea to Physical Output

20 3.0 Architectural Design Problem

    3.1 Purpose

    3.2 Architectural Program

    3.3 Construction Program

    3.4 Proposed Solution

    3.5 Design Information Translation Comparison

30 4.0 Hypothesis

    4.1 Broad Research Question

    4.2 Secondary Research Question

    4.3 Expected Results

    4.4 Contribution to Research

33 5.0 Methodology

    5.1 Process of Investigation

    5.2 Designing the Fabrication Process

42 6.0 Experimentation

    6.1 Introduction

    6.2 Process

	6.0 Experimentation (continued)	
	6.3	Formwork 1
	6.4	Formwork 2
	6.5	Formwork 3
	6.6	Formwork 4
	6.7	Formwork 5
	6.8	Formwork 6
	6.9	Formwork 7
	6.10	Formwork 8
	6.11	Formwork 9
	6.12	Formwork 10
	6.13	Formwork 11
	6.14	Transferring Design Information
79	7.0 Conclusion	
	7.1	Summary of Formwork Experiments
	7.2	Design & Fabrication Process Methodology + Knowledge
	7.3	Making
	7.4	Implementation
94	8.0 Figures	
98	9.0 Bibliography	

1.1 Motivation

The success of making a building can be directly related to the management of information. Concepts are derived from a client's needs and desires, site characteristics, and building codes. These concepts are then developed and refined into an agreed upon solution that satisfies the owner, architect, engineer and municipality. This solution is then translated and packaged into graphical drawings and specifications on paper and delivered to the constructor. The constructor then translates the graphical drawings and specifications into the physical artifact.

This relatively simplified sequence (Fig. 1.1.A) illustrates many of the inherent difficulties within the building industry today.

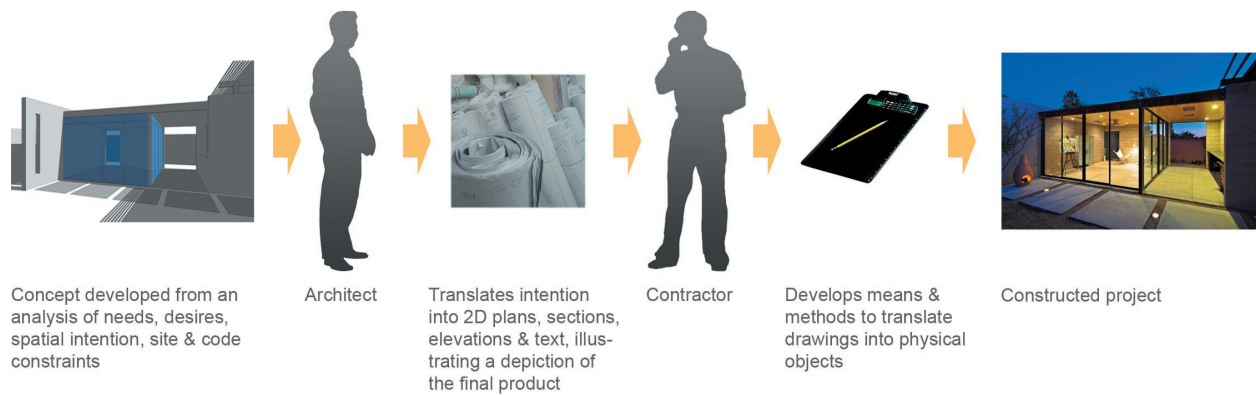

Figure 1.1.A

As illustrated from the above diagram, the potential for information breakdown becomes clearly visible. Architects work with owners to design buildings three dimensionally. They utilize computer and physical modeling to convey ideas and exchange information at scales from the largest urban context to the smallest fastener. This three-dimensional information is then translated by the architect into plans, sections, elevations, and text that are graphically accepted methods of communication. Constructors then must work to re-translate the information conveyed in the plans, sections, elevations and text into a physical three-dimensional object by developing the means and methods used to create the desired outcome. When mistakes occur during the construction process they can almost always be rooted

to either information that failed to be conveyed in the drawings, misunderstood by an entity within the constructor team, or executed by means and methods not considered during the design.

## 1.2 Reach Objective & Outline

The objective of this research is to develop a new method in which complex design information can be better communicated to the fabricators making the building. This thesis will also look at the processes and techniques that are currently used and the ones that are poised to transform the industry.

This investigation begins with a survey describing the development of the relationship between the designer and fabricator to understand how the industry has arrived at its current mindset. From there a hypothetical architectural design problem of desert relief shelters (Fig. 1.2.B.1), propagated throughout southern Arizona, is laid out and subsequently utilized to illustrate a newly proposed design translation methodology (Fig. 1.2.B.2).

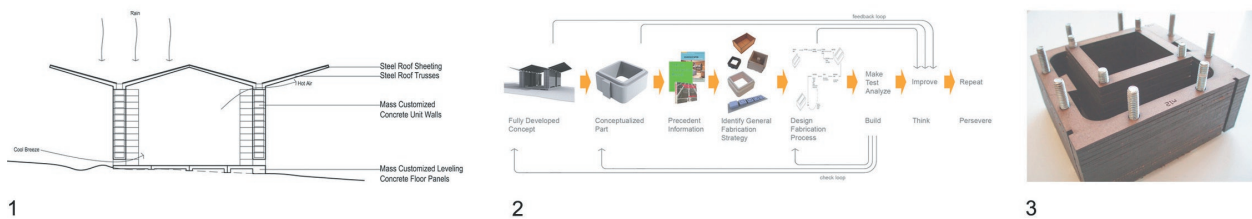

Figure 1.2.B

From the methodology, the fabrication process for a component is designed and a method of creating rapidly generated mass customized concrete formwork through negative layer fabrication (Fig. 1.2.B.3) was conceived. After rigorous experimentation, the process was refined and the methodology tested. Finally, extracted conclusions from the work are summarized.

## 1.3 Importance of Research

The importance of this research can be described by three presumptions. First, our capacity to create better and more innovative buildings is increasing but is being stifled by our inability to change our design to construction methodology to embrace these new advances. Second, the separation between the designer and the



fabricator is distant and growing; however, the advantages of a fluid relationship are mutually beneficial. Lastly, making buildings requires more graphical and textual information than ever before, causing the need for appropriately and efficiently managed information critical to the success of a project.

#### 1.4 Uniqueness of Study

The investigation of this study is unique in several ways. It focuses on fabrication issues within small scale projects with modest budgets in contrast of unlimitedly funded projects where the only constraint is the designer's imagination. By limiting the cost as a dependent variable, it forces realistic decision making that can be more easily implemented into the mass market. Also, the aim of this thesis is to propose a new methodology and reveal technical information through physical application.

#### 1.5 Past Research

Previous research resides in two primary streams, the theory of making and the development of new technologies and materials. Professional practitioners such as Gehry Partners, Kieran & Timberlake, William Massie and Tri Pyramid have all examined the process of building and contribute to the evolution of fabrication and the role of making in architecture. They also propose directions for improvements and distain for flawed process. Technical information for emerging tools and materials is widely available. Research has been executed both in pragmatic and academic settings. The aim of this research is to propose new theory and defend it through technical means and methods.

## 2.0 Background & Purpose

### 2.1 Process: History of the Designer and Constructor Relationship

[master builder]



Figure 2.1.A

In 1418, Filippo Brunelleschi entered a competition to “make any model or design for the vaulting of the main dome” (King 200) of the Santa Maria del Fiore Cathedral (Fig. 2.1.A) under construction in Florence, Italy. Original building had been started on the Cathedral in 1296 but the design called for an enormous dome (143 feet in diameter) to be constructed hundreds of feet in the air with no flying buttresses that typically supported the lateral loads of Cathedrals all over Europe.

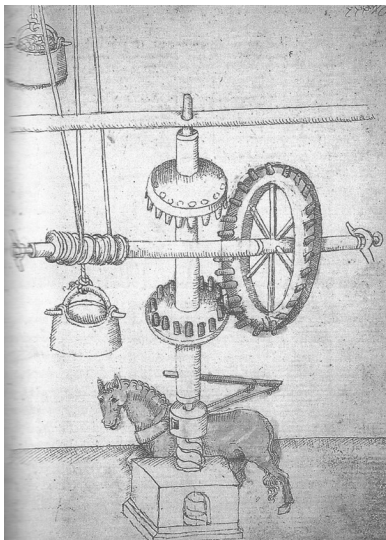

Figure 2.1.B

Brunelleschi engineered the dome by designing the angled placement of all brick in combination with the ribbed arch supports. The material composition of the brick and mortar was developed to achieve the desired final loading and support during construction. He created the dome as an architectural keystone, perfect in proportion, scale, and space. Not only did he supervise the building process but he also developed the tools required for construction such as the helical screw jack (Fig. 2.1.B). Finally, he managed the scheduling and juggled the politics.

Brunelleschi was a master builder. By combining the roles of engineer, material scientist, architect, builder, and manager he was able to maintain a clear singular vision and account for all processes in order to achieve what was thought to be an impossible endeavor.



Figure 2.1.C

More than 200 years later, during the Japanese Edo Period (1603–1868), the ideology of the master builder still existed. At this time it was manifested through the master carpenters responsible for building temples (Fig. 2.1.C), shrines and tea houses. They were referred to as *Daiku* whose etymology was derived from “chief” and “artisan”. They were held in high social regard and according to Buntrock, “were the only trade that was, as a rule, allowed to sign their work, a privilege otherwise specifically extended only to the most talented crafters”. (Buntrock 2002)

[segmentation & specialization]

Sometime between the end of the Japanese Edo Period and now, the profession of making buildings has become divided and segmented.

The role of architect, builder, engineer, material scientist, and manager are now five distinct entities. It is obvious that this division occurred when buildings became increasingly more complex with the advancement of new materials and technology. However, negative ramifications have rippled throughout the industry in response.

Communications between the five entities becomes absolutely critical. Improperly managed information can cause anything from slight mistakes to enormous crippling errors. The constructor has now assumed the role of the means and methods of construction. Innovative techniques for accomplishing novel tasks such as Brunelleschi's screw jack are now often value engineered from the project and reduced to conventional methods. In this scenario, Brunelleschi's dome would have been deemed impossible to build and may never have been realized.

The architect is now responsible for orchestrating a multitude of entities with often differing self interests. A singular vision is blurred, conflict begins to occur, inefficiencies start to arise, and litigation becomes common practice. Overall innovation begins to slow; better ideas are sacrificed for conservative solutions, and the entire building industry progression is stifled.

[downfall of our current methods]

The problems in current professional practice are not solely from the segmentation of separate entities but from a variety of inefficient methods ingrained into conventional process.

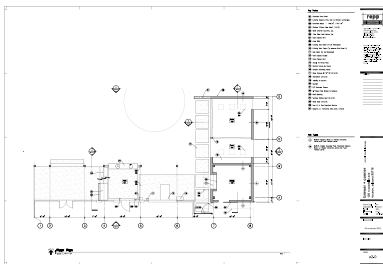

Figure 2.1.D

We utilize two dimensional paper drawings (Fig. 2.1.D) as our current method of translating design information because it was the best technology available at the time it was developed. Hence, designs for buildings were also conceived and worked through with clients on these two dimensional paper drawings which made for an efficient translation to constructors. Currently, designers utilize paper drawings, digital computer models, renderings, physical models, and mockups to exchange design intention with their clients. It is overly optimistic to assume that constructors can extract all the information of these newer techniques when the rich design information is translated back into archaic two dimensional paper drawings. When creating complex buildings, two solutions exist to owners and architects. Either hire only exceptionally skilled contractors able to decipher and execute mass amounts of design information or change our current methodology of translating design intention.

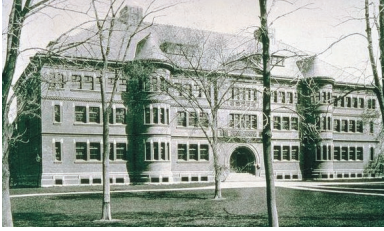

Figure 2.1.E

H.H. Richardson was able to construct Sever Hall at Harvard University (Fig. 2.1.E) with 6 sheets of drawings in 1880. (Jennings 2007) A current building of comparable size and scope is likely to be more than a hundred pages of drawings accompanied by several hundred pages of specifications. The amount of information transferred between hundreds and sometimes thousands of people is at an all time high. Communication can become time consuming and painstaking. The ability to embed a greater amount of information in less volume will lower mistakes yielding higher quality buildings at less expensive prices.

As illustrated by the building industry value chain below (Fig.2.1.F), our current methodology reiterates the fact that increasing the separation between the designer (who conceptualizes the part) and the fabricator (who makes the part) increases the cost and decreases

Traditional Value Chain - Design to Production

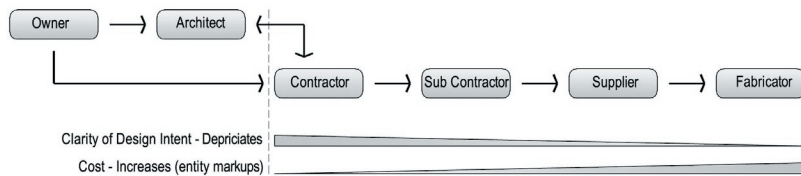

Figure 2.1.F

the clarity of intention.

The law of economy and value states that  $Quality \times Scope = Cost \times Time$ . This is the current paradigm in which the production of buildings exists today. The desirable aspects of anything we make are quality and scope. We like things that are made well; they have craft and an increased longevity. This country is also a consumption based market, if we like something we want more of it and we increase its scope. In contrast, we tend to dislike cost and time. Cost and time are the limiting factors that determine the quality and scope of something we want.

Automotive industries have been working to change the law of economy to meet new client mandates, the revised equation now reads,  $Quality \times Scope > Cost \times Time$ . The price of automobiles rise slightly ever year but the amount of features increases much faster. In other words, consumers are demanding more for less. According to Kieran, "These lessons are not about outward form, style, or

appearance. They are about processes and materials developed over the past decade that have overturned the ancient equilibrium between expenditure or resources and acquisition of benefits.” “Anybody can give you more for more; it takes a real genius to give you more for less.” (Kieran 2004)

[practice]

Until recently, three major contract types for delivering a project from design to construction existed. Traditional delivery, also known as design – bid – build was the predominant mode of delivery in the U.S. for many years (Gould 2000). In this method, owners would hire an architect to prepare a design and subsequently construction documents. The owner would then either enter into a competitive bid for the lowest construction price or work with a contractor for a negotiated fee. The advantage of design – bid – build is its familiarity within the industry making it easily accessible for a large population.

Another popular delivery method is referred to as design / build. Design / build project delivery can either exist as a single entity that provides both in house design and construction services or may be two separate firms that create a joint venture for a specific project. The advantages of design / build are that an owner has one point of contact throughout the entire project and the team approach between the designer and contractor makes for much better communication. Also, both the design and construction teams share a common goal and liability making for a less adversarial relationship when compared to traditional delivery. Although there are many advantages to design / build there are equally as many disadvantages. First, it is difficult for an owner to obtain a GMP (guaranteed maximum price) early in the project because with a shared interest the design firm could potentially tailor the design of the project to meet healthy profits for the construction. Instead, owners must provide a general idea of project cost and solidify pricing near construction document completion. Second, there exist few checks and balances within design / build. In traditional delivery, the architects become consultants to the owner during construction to verify the quality of work being performed. This is more difficult to achieve in design / build unless a third party firm is brought in to oversee performance.

The last common delivery method is Construction Manager usually executed as Construction Manager at Risk (CM at Risk). In this method, an owner hires an architect and construction manager early in the project. Both the architect and construction manager report

to the owner but communication is improved because of the dual entities working together. As the design progresses the construction manager is able to provide cost and schedule information to the owner to assist in decision making. At the end of construction documents the construction manager provides the owner with a guaranteed maximum price and construction commences. The advantages of this method are the good communication between the architect and contractor combined with the separation of power which is usually more appealing to the owner. The disadvantage to construction manager delivery is the potential for team members to become inflexible or unavailable. Also, while the owner may enjoy not having to worry about potential cost overruns the contractor has most certainly accounted for this by increasing the contract price. If the market is stable, the contractor stands to make a large sum of money. Conversely, if the market turns down (prices increase) the contractor may take a large loss.

[emerging practice]

The above three project delivery methods are commonly used to handle the majority of typical construction within the U.S. However, many architects and contractors involved in producing innovative projects have found it difficult to produce their work within the established methods. In response, several new methods of project delivery have emerged to improve the relationship between designing and making.

[integrated practice]

“The inefficiencies inherent in the process of design and construction are necessitating a shift to greater multidisciplinary collaboration and information sharing among project team members”, according to Pressman. (Pressman 2007) The idea behind Integrated Practice is similar to design / build but involves a larger scope of people involved within the project. Architects, owners, and constructors work with design consultants, sub contractors, and suppliers to meet project goals together. They typically employ new technology to exchange vast amounts of information and decision making is more collective. The concept of designer ownership is replaced with team authorship.

[fabricators as consultants]

Gehry Partners changed the model of standard architectural practice when they found the current process non conducive to implementing their building typology. Because of the inventiveness of their designs,



Figure 2.1.G

it would have been impossible to deliver their projects via one of the 3 traditional project delivery methods. There was a high risk of developing a project that was non constructible. In order to accommodate their production, Gehry Partners brought in fabricators early into the design process. By doing this, they guaranteed that their design solutions could be executed to an expected level of quality at a proposed price and timeline. (Fig. 2.1.G)

[manufactures as designers]

Recognizing the disconnect between high design and manufacturing, Tim Eliassen founded Tri Pyramid Structures (Fig. 2.1.H) to be a full production manufacturing facility with a design studio in the next room. In this model, designers work side by side with the machinist fabricating the parts. Feedback loops are instantaneous and communication between the two entities is seamless.



Figure 2.1.H

## 2.2 Making: Idea to Physical Output

[evolution}

Assemblies are generated in 3 ways, a singular craft, an assembly line, and modularized and component construction. Many industries in the business of making have evolved through these methods. For example, early automobiles predating the 1913 Ford 'Model T' were constructed individually by expert mechanics that knew the workings of every part. The assembly line (Fig. 2.2.A), which followed singular craft, increased production and improved performance of the product. Currently, automobiles are constructed by modularized components (fig. 2.2.B). The instrument panel, drive train and cockpit are all separate objects fully constructed in ideal conditions and brought together for final assembly.



Figure 2.2.A

[parts, connections & assemblies]



Figure 2.2.B

The connotation of the word connection often infers the joining of two objects together. Assembly means the joining of many things together. The making of buildings often focuses on its parts as isolated pieces. We tend to think of components as separate objects, a window, a light fixture, a door handle, and a tile. Looking deeper, a duct, a vent pipe, a circuit breaker, and a vapor barrier. Why has this occurred? Building components are produced by individual companies with separate interests, such as performance, aesthetic or cost. Another industry

exists solely to serve the joining of isolated objects. Screws, bolts, nails, glue, and tape are a critical part of building but over reliance on their use is diminishing quality when compared to a well thought out assembly. Caulk, foam, spackle and trim exist almost entirely to cover up mistakes and differences when joining objects together.

The ability of architects to design the connection of materials in such a way to minimize assembly error and increase craft through material imposed constraints is no longer held to a visual standard only. Is it possible to design the assembly of objects in such away that it only 'fits' correctly?

[craft]

Craft is a diminishing characteristic. Pride in one's work is quickly being replaced by sentiments of faster and cheaper. With the loss of craft, construction becomes sloppy and wasteful. When exterior materials do not align air infiltrates the layer. HVAC systems work harder to adjust climatic conditions, energy is wasted, bills increase and more greenhouse gases are emitted. Exterior materials break down at a rapidly increased rate when not installed accurately or to a specified level of finish. A poor weather proofing installation will diminish the useable life of the building, costing the owner more money, wasting materials, and causing higher litigation fees for the building industry. Craft is not tied solely to a buildings visible appearance but instead its overall performance, longevity, usefulness, and cost.

[handcraft vs machine craft]



Figure 2.2.C



Figure 2.2.D

Not long ago, handcraft was the only method of producing. Tremendous amounts of human effort (Fig. 2.2.C) and time were expended to make. Handcraft was not a luxury, the economies of the situation still needed to prevail. Machine craft was a dream that would allow for less human effort and time to produce greater quality at a better cost. As previously mentioned, many industries such as the automobile, aerospace, electronics and product making industry have all embraced machine craft. Time has refined their processes and has allowed designers and fabricators to work with their tools in an integrated fashion. The building industry has failed to fully realize the potential of a better methodology. The outcries shaming the loss of human craft were soon drowned out by inexpensive production building that exploited "human craft" to its lowest possible price without regard for quality (Fig. 2.2.D). The economies of the situation prevailed. Actual human craft is a luxury afforded to large budget



projects, machine craft integrated with designers and fabricators is a method of providing quality at a better price.

[mass production vs. mass customization]

Mass production was the ideal method of making for the 20<sup>th</sup> century. Standardized processes allowed for one object to be repeated in enormous quantities. By doing so, quality remained consistent and costs remained low. Mass customization is the new method of making for the 21<sup>st</sup> century. Process models are designed with a degree of flexibility to allow products to be tuned to the needs of the consumer. Dell Computers pioneered early work in mass customization by allowing customers to select their specific configuration to meet their needs. Internally, Dell organized production by accommodating variation to a limit, which allowed for the product to still be produced in high volume and at a controlled cost without becoming a one-off supplier.

[emerging design methods]

Tools that designers work with to conceive, develop and produce design information are also evolving. For more than 200 years, architects have used paper drawings to communicate design intention. (Woods 1999) However, as buildings become increasingly complex with systems and detailed components the limitations in conveying information strictly through two dimensional drawings is evident.

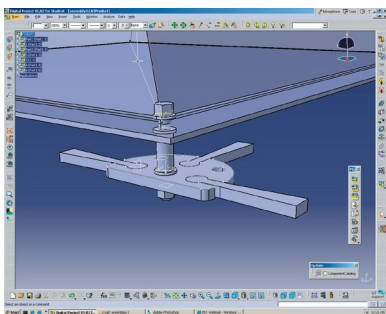

Figure 2.2.E

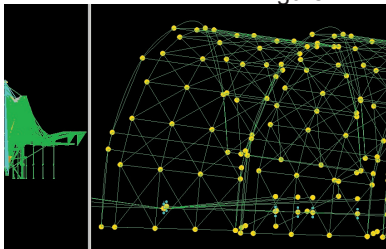

Figure 2.2.F

In response, designers are switching to improved methods of working with design information. Solid modeling (Fig. 2.2.E) is object based design software that simulates real life conditions within a digital environment. Typical problems of tolerance, part conflict, connection fitting and space for construction work are overcome with every part worked out three dimensionally and considered dependent of its assembly.

Parametric modeling (Fig. 2.2.F) combines solid modeling with the ability to create hierarchical and bi directional dependencies within the model. Therefore, if the size of one component, such as a piece of steel, is changed all elements that have a direct relationship with that element can automatically adjust and accommodate the modification. This technology drastically reduces revision time and human oversight. However, it is important to point out that parametrics are most useful when applied to conditions where the possibility of change is foreseen and minimum and maximum limits are defined. Because

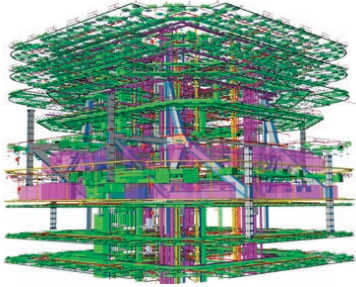

Figure 2.2.G

of the hierarchical nature of the structure, it is impossible to link every element together without creating self-referential geometry. Thus, certain elements must drive and other elements must be driven within the model.

Building information modeling (Fig. 2.2.G), or BIM, is the fastest growing new tool with the largest user base only second to traditional representation. BIM allows users to embed data directly into digital models that provide teams with quickly extractable information such as components size, manufacture, finish, cost and schedule. “More than a new way of drafting, BIM is really a paradigm shift for design and construction. Its adoption forces examination of a host of practice and business issues, from the definition of professional roles to liability to project delivery methods”. (Gonchar 2007)

[emerging fabricating methods]

Advancements in fabrication have improved the process of making at both the model scale and full size production levels. These new technologies can be divided into 2 major categories, additive process machines and subtractive process machines. (Seely 2004)

Additive process machines make by physically adding material in a layered fashion to create a desired shape. Fused Deposition Modeling and ZCorp (Fig. 2.2.H) printing are two examples of such machines. Both operate in a similar fashion to an ink jet printer in that a head moves back and forth on a gantry applying material. Additive process machines are good extensions of three dimensional digital computer modeling. With relatively little translation, these digital models can be sent directly to the machine and a physical model is ready in a matter of hours. These machines are mostly used for rapid prototyping, quickly modeling something before it is sent to production. Rarely do these machines provide actual products; they are utilized more as representational tools for real life simulation.



Figure 2.2.H



Figure 2.2.I

Subtractive process machines include laser cutters (Fig. 2.2.I), water jet cutters and numerically controlled routers often referred to as CNC machines (Fig. 2.2.J). In subtractive process machines, sheet material is inserted into the device and is cut, routed or milled (subtracted) to reach the desired outcome. Small size laser cutters are generally used for modeling purposes and can be easily scaled up to production with a CNC router. In contrast to an additive process machine which can easily accept any three-dimensional shape sometimes users have to translate their designs to accommodate



Figure 2.2.J

subtractive process machines. CNC routers can do a certain amount of milling (three dimensional surfacing) but usually up to 4" on a 48" x 96" table. In most cases, two-dimensional shapes are cut from sheets and assembled to create three-dimensional forms. Hence, models that are derived three dimensionally are then user translated to two-dimensional cut sheets. Translation error, connections and tolerance all become factors that need to be considered in the design to facilitate its making.

## 3.0 Architectural Design Problem

### 3.1 Purpose

In order to test the effectiveness of a new methodology that deals with the translation of design intention into fabrication, a hypothetical design problem was set up and tested. The conditions of the design problem were to be as follows. First, the project had to contain some portion in which a custom component could be identified and the means and methods for fabricating it could be explored at great length to unveil undiscovered knowledge. Second, the project had to be small in budget and subsequently most likely small in scale. The reason for a small budget is that anything can be fabricated with enough money, to really advance the methodology an economic constraint forces realistic conditions and practical solutions.

### 3.2 Architectural Program

For the design problem, a multipurpose remotely located desert relief shelter was selected. The following architectural program was initialized.

Use	Refuge from the sun and harsh desert environment; collection of rain water, passive solar energy, wind.
Typical occupants	Shelter for campers, hikers, hunters, nature researchers, off road enthusiasts, migrant border crosses, border patrol agents.
Size	Approximately 200 to 400 square feet.
Location	Various spots located remotely (greater than 25 miles from any fairly populated communities within the southwestern US).
Materials	To be determined during the design process.
Structure	To be determined during the design process.
Systems	No active electrical, mechanical or plumbing systems – subsistent systems only.

### 3.3 Construction Program

Because it was determined early on that the purpose of this project was to investigate a potentially new methodology for making buildings the construction program became as equally important as the architectural program in terms of defining constraints that would add to the depth of the research and make it a more realistic project.

Transportation	The building components must be delivered to a variety of remote sites by truck and trailer (non semi) in an economical manner
Utilities	No onsite water, gas, or electricity will be assumed to be provided. Any utilities required for field construction will need to be transported and considered part of the design solution.
Field Assembly	Field construction must take place by hand – it is assumed that no cranes of heavy lifting equipment will be available.

### 3.4 Proposed Solution

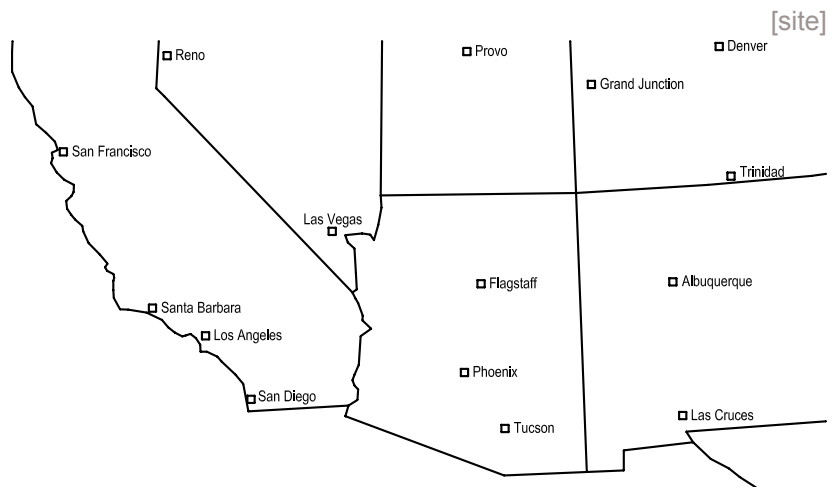

Figure 3.4.A

The proposed project sites are located within the rural areas of the southern region of the state of Arizona (Fig.3.4.B). These areas are shared by a variety of people including campers, hikers, hunters, nature researchers, off road enthusiast, migrant border crossers, and border patrol agents.

The shaded area of the map shows the approximate amount of land located more than 25 miles from a fairly populated area (Fig.3.4.C). Twenty one different sites for desert shelters have been identified.

The site located between Tucson and Sells, Arizona and will serve as the typical site for this investigation. It is located on a slight east slope against the base of several large hills directly to the south.

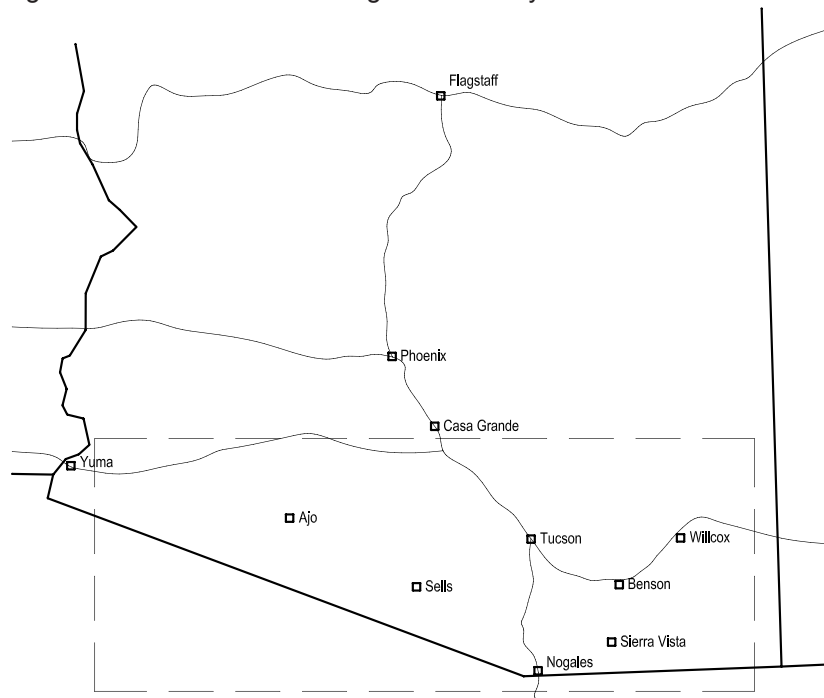

Figure 3.4.B

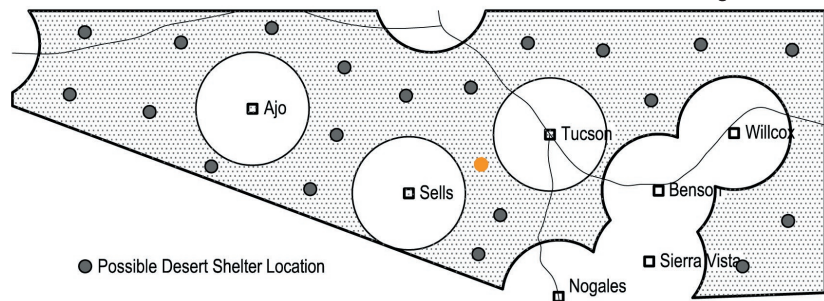

Figure 3.4.C

The proposed design of the shelter will allow for the same design to be constructed at each of the outlined locations. However, the foundation and floor plates will be customizable to accommodate the terrain discrepancies between each location.

The site is predominately rocky with hard soil and mixed desert vegetation (Fig.3.4.D). The prevailing breeze comes from the northwest but it is likely to get winds from any direction. Tucson is

approximately 35 miles to the northeast and Sells is approximately 35 miles to the southwest. Interstate-10 is approximately 27 miles due east. There are no man made features near the site. The minimum soil bearing pressure for Pima County is 1500 PSF. The annual rainfall in this area is 12.26”.

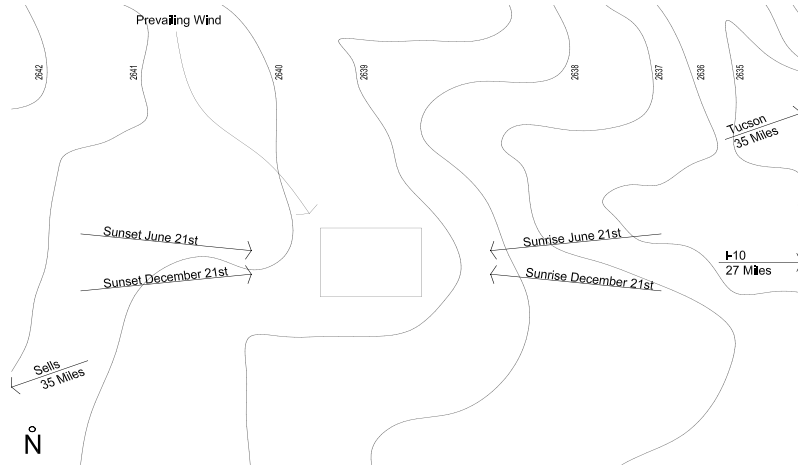

Figure 3.4.D



Figure 3.4.E

[conceptual drawings]

#### Section

This building serves as a vessel for collection and release (Fig.3.4.F). Varieties of temporary inhabitants briefly use the shelter as relief from the harsh desert environment before going on their way again. Water is collected during desert rains and stored in the cavity of the bearing walls to be later used by people.

The floor panels are mass customized to accommodate terrain variations between different sites (Fig.3.4.G).

#### Plan

The plan of the structure serves to block the hot west sun with the west walls (Fig.3.4.H). The south sun, which is controlled by the specified roof overhang, being blocked during the summer and let in for warmth during the winter (Fig.3.4.I).

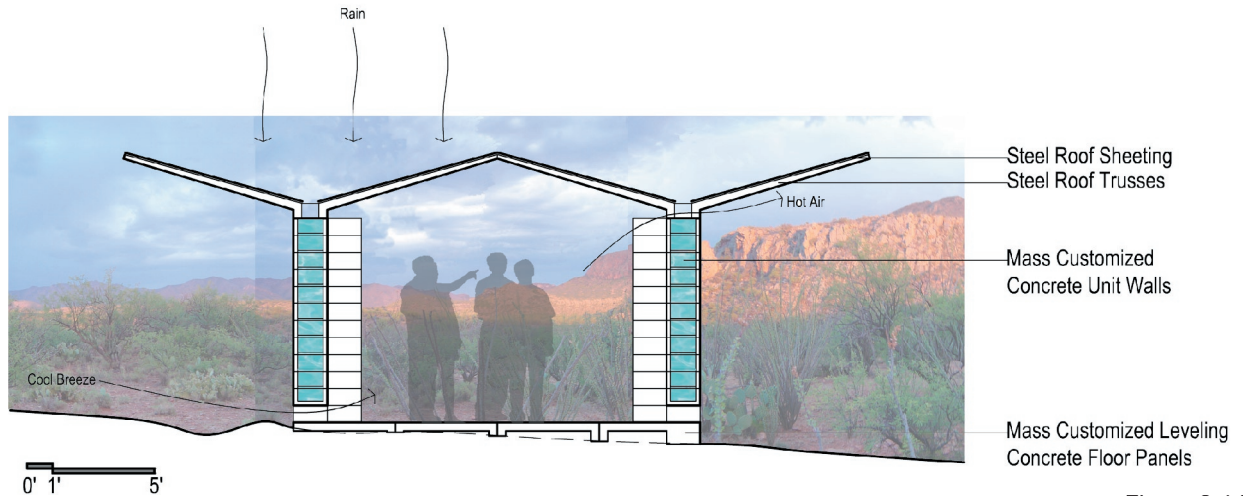

Figure 3.4.F

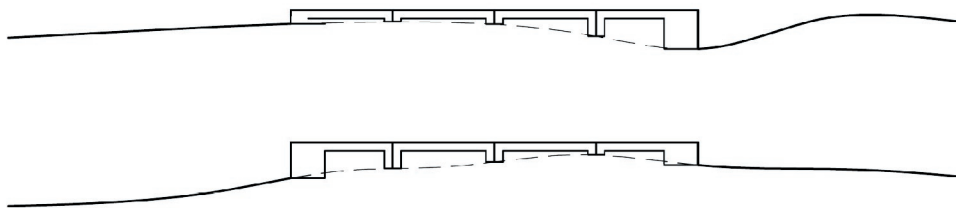

Figure 3.4.G

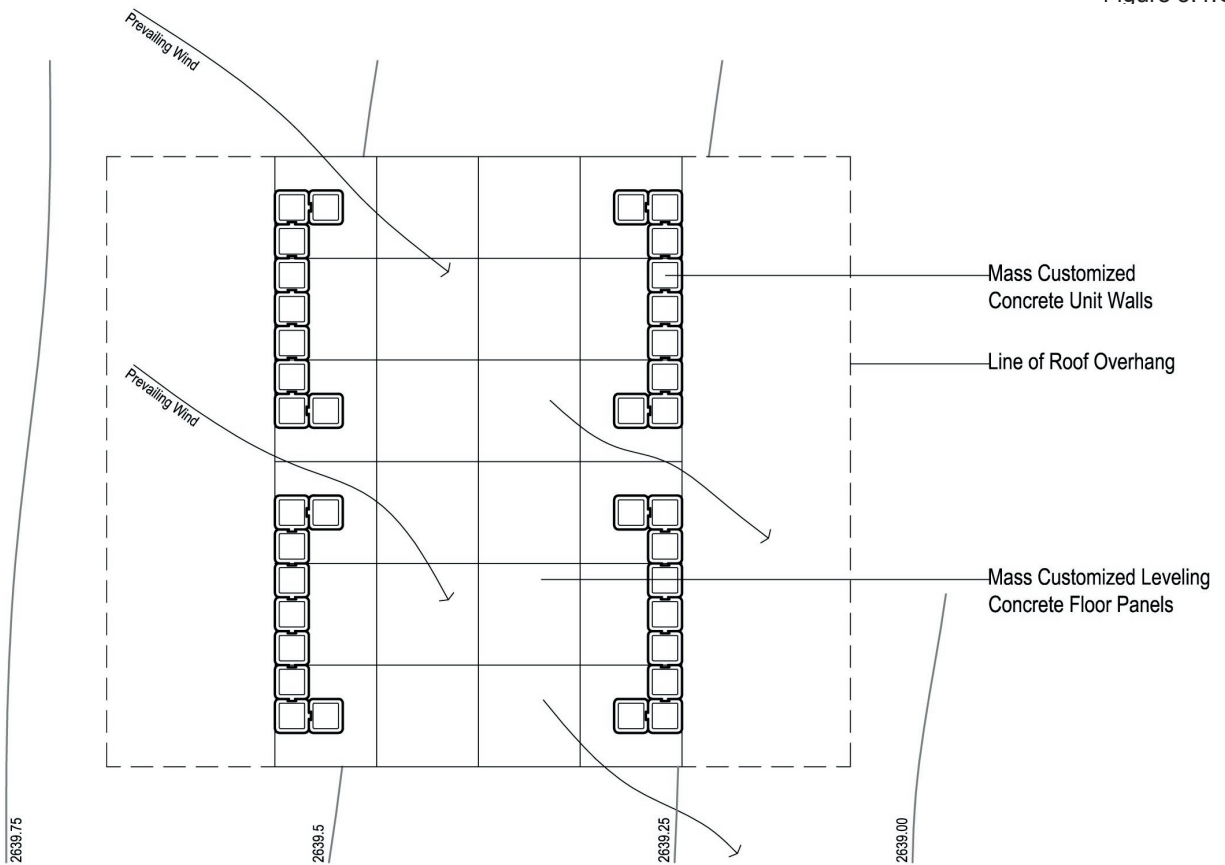

Figure 3.4.H



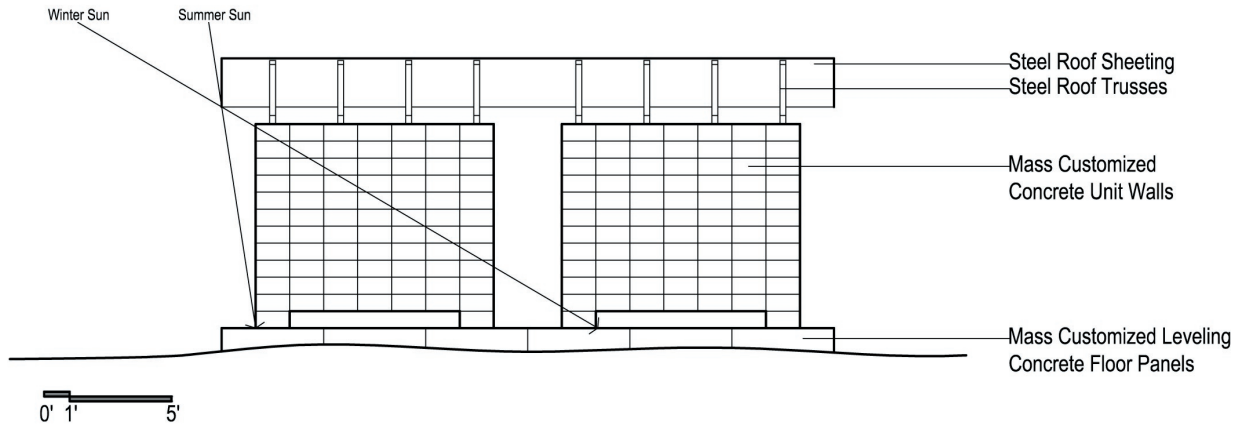

Figure 3.4.I

[structure & material concepts]

The structure of the shelter is comprised of four primary parts (Fig.3.4.J). The roof sheeting, roof trusses, mass customized concrete wall units and mass customized floor panels.

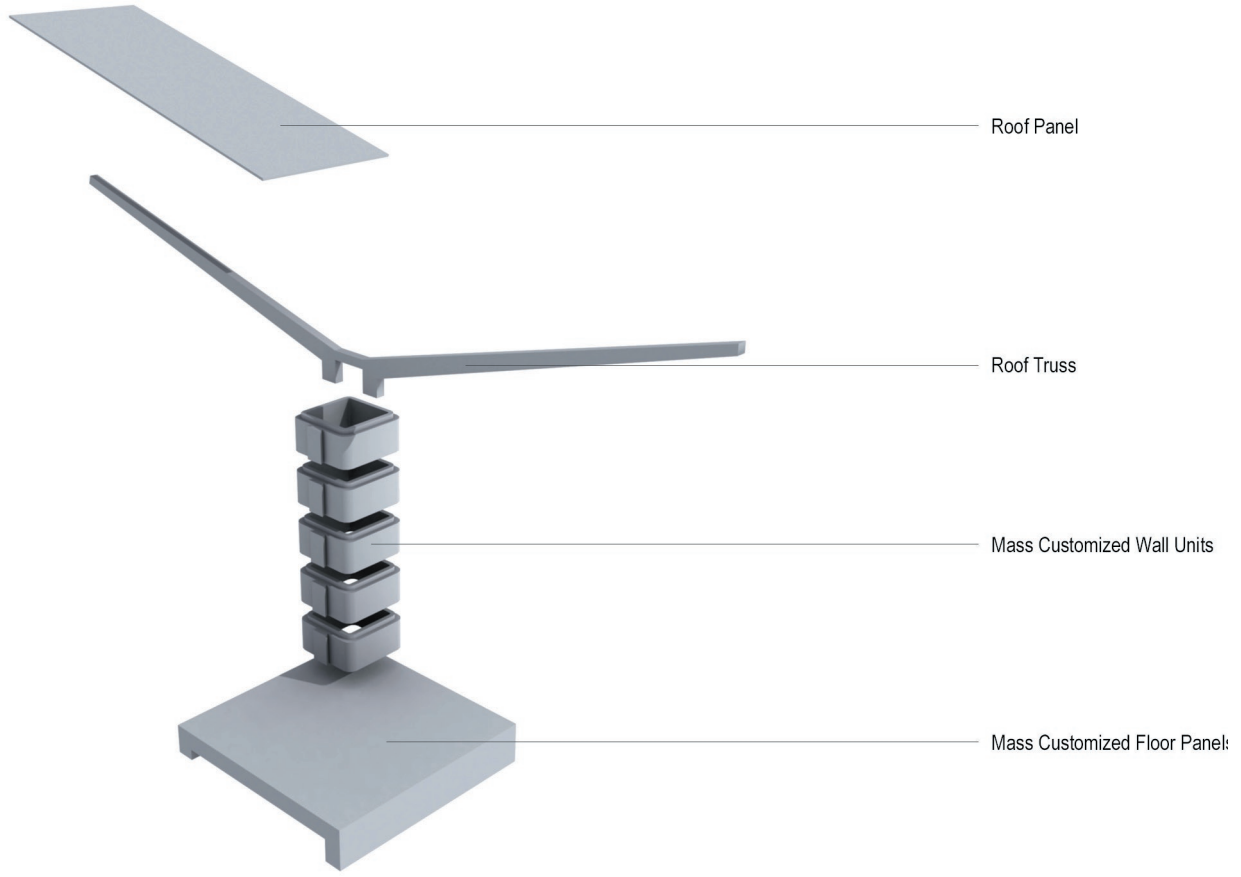

Figure 3.4.J

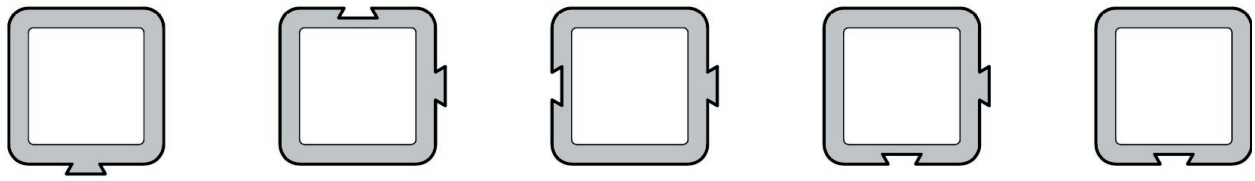

Figure 3.4.K

The concrete wall units are mass customized into 5 primary shapes that allow the current configuration (Fig.3.4.K). By alternating the arrangement of the connections any variety of configurations is possible.

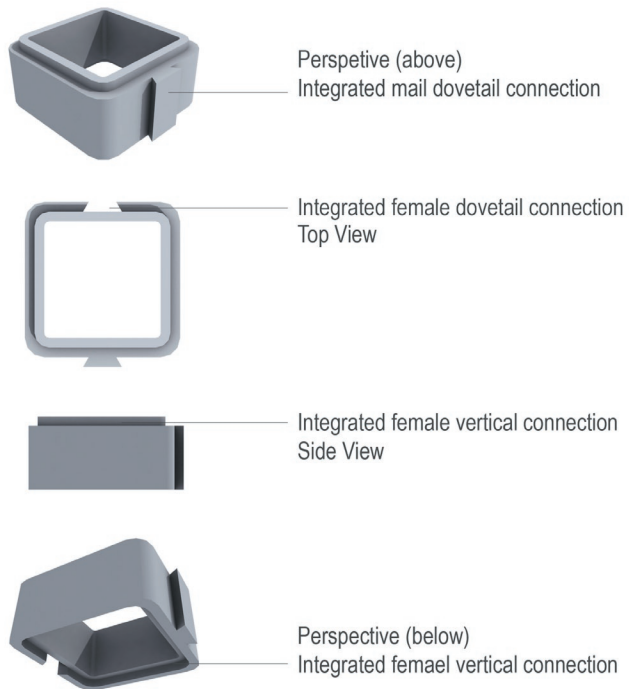

Figure 3.4.L

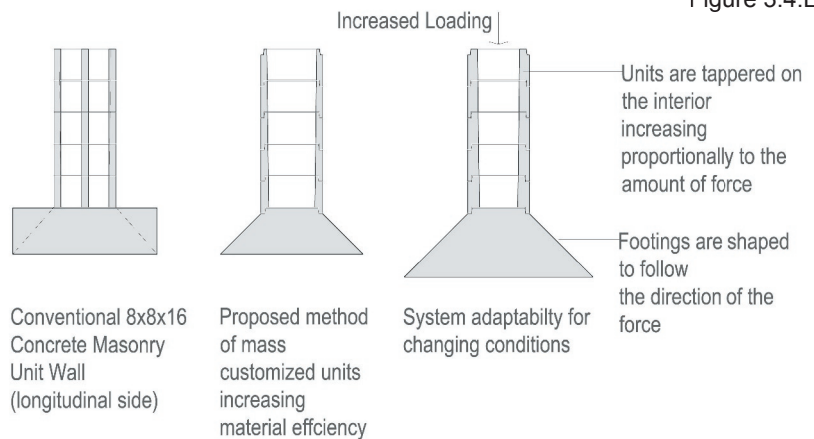

Figure 3.4.M



Figure 3.4.N



Figure 3.4.O

The above renderings show the fully developed design of the desert relief shelter.

### 3.5 Design Information Translation Comparison

At this point, in a typical project, the above design would now be translated into two dimensional drawings that communicate the design information. For comparison, drawings of the project have been produced in both the traditional method (Fig. 3.5.A) of commonly accepted graphical drawings and a potentially new method (Fig. 3.5.B) of component based fabrication drawings and assembly instructions.

From the comparison of the below two methods it is visible to see that the traditional method of translating design information into construction requires a highly skilled constructor to interpret the intent and implement the means & methods required to execute the design. The proposed method of translating design information provides the constructor much clearer information and should hypothetically make the construction process easier.

Figure 3.5.A

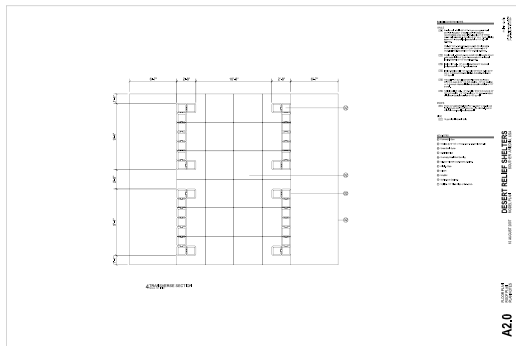

floor plan

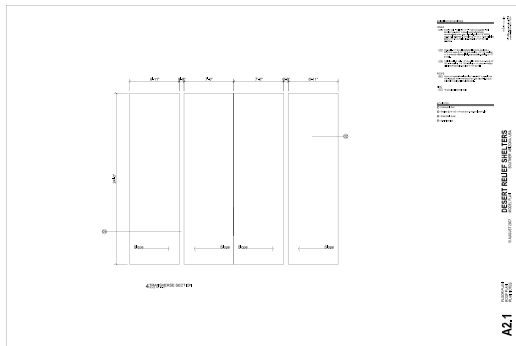

roof plan

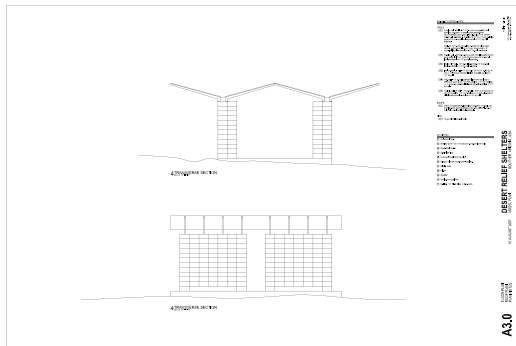

elevations

Figure 3.5.B

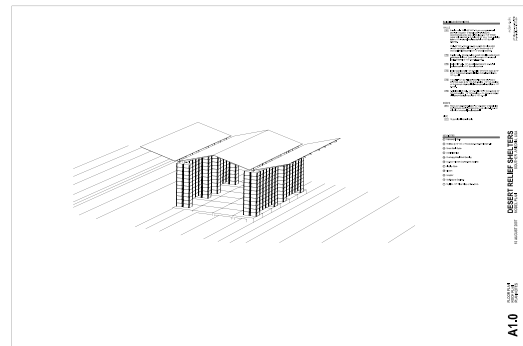

concept diagram

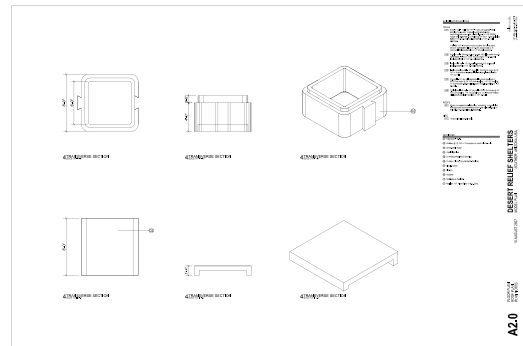

part drawings 1

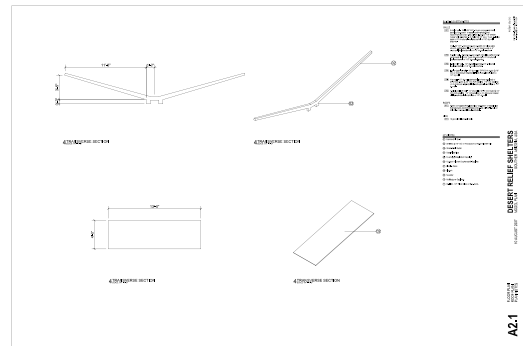

part drawings 2

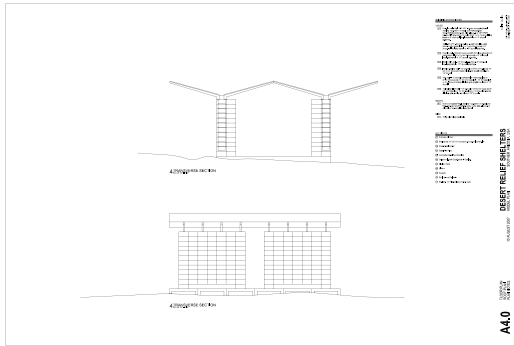

sections



assembly instructions 1

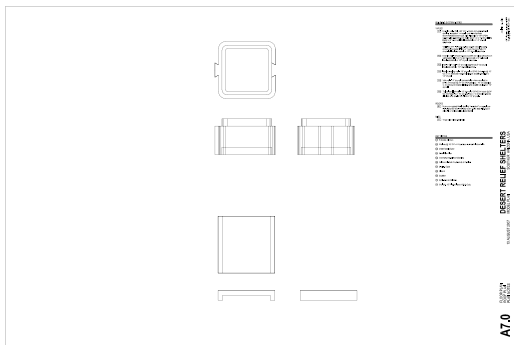

details

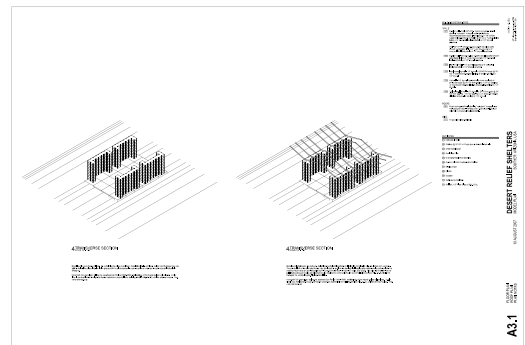

assembly instructions 2

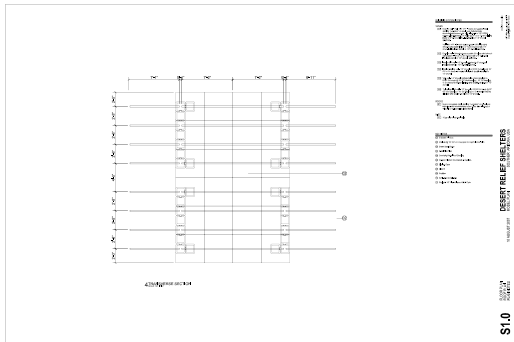

foundation plan

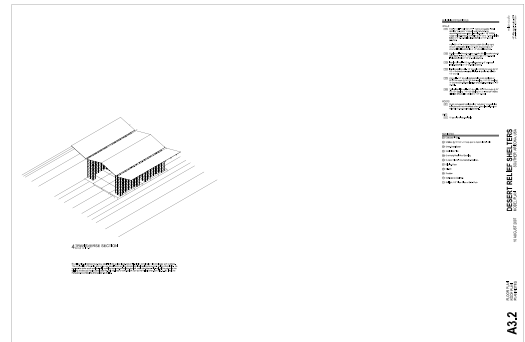

assembly instructions 3

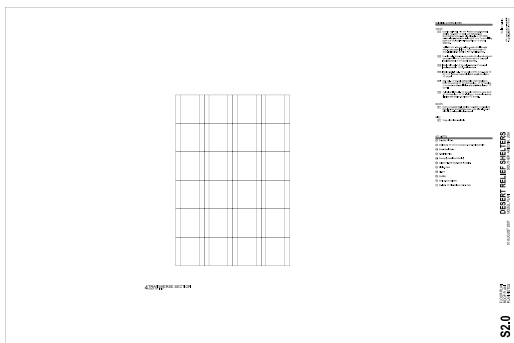

framing plan

### 4.1 Broad Research Question

As illustrated by the previous comparison of traditional design translation with a proposed alternative; in addition with all of the inconsistencies that exist in our current building industry mindset combined with our emerging tools and processes, is it possible to create a new methodology of translating design intention into fabrication?

The major advantages of successfully developing such a system would be the ability for designers to offer their clients higher quality products at a lower cost and reduced amount of time. This would be achieved by the designer again taking an active role in the means and methods of production and repackaging that information to communicate the necessary intention in the least amount of output. This type of methodology is geared towards tectonic based architecture with a kit-of-part assembly.

The potential disadvantages of the new methodology could be the imbalance of liability and risk when inserted into the current insurance system. These obstacles could be overcome by reorganizing coverage or operating in collective intelligence. Also, this type of methodology may not work well for projects in which little part fabrication is required.

### 4.2 Secondary Research Question

From the broad hypothesis, the next pertinent questions would ask, what is the method for translating and designing the fabrication process of a part based building? How do you go about designing a process that can be applied to a wide variety of potential design problems? For this a series of steps will need to be developed. Careful distinctions will need to be made in order to separate linear and methodical process from free flowing designing. It is also easy to quickly isolate part design and therefore the design process should include the ability to create the part in consideration of the entire assembly.

### 4.3 Expected Results

The aim of this thesis will seek to investigate four expected results concerning method, process, communication, and fabrication.

[method]

A new methodology that expands from traditional process and seeks a way of embracing emerging technology, skills and materials under the constraints of the mindset of the current building industry will flourish in its ability to create higher quality products for less time and cost.

[process]

The ability to design the means and methods in which complex components will be fabricated ensures fewer errors in the product providing better quality. It is expected to show that when a designer only produces graphical information depicting the final iteration of a part there is a lack of embedded information that the designer is not able to communicate through traditional channels. By designing the process in which the part will be made, the designer embeds another level of design information such as but not limited to, tolerance, part relationship to the whole, and assembly information.

[communication]

By considering the ways in which things will be made, designers have the ability to embed intelligent information concerning its fabrication directly into the part. For instance by designing a joint that can only be installed only one way, less graphical and textual information needs to be provided in the drawing set depicting the proper orientation of the said part. When this principal is arrayed throughout the entire process, the amount of information that a constructor must manage is greatly reduced and allows him or her to perform better in less time.

[fabrication]

Just as machine craft and mass production were the idealized manufacturing methods at the turn of the last century; mass customization, automation and rapid generation are the emerging tools for this century. Mass customization will allow designers to produce unique and specific parts more efficiently through the reduction of waste. Rapid generation and automation will assist this production with the ability to create continuous diverse parts at mass produced

speeds. This new system of making will also provide consistent high quality without the dependency on high cost skilled labor.

In summary, the expected results of this investigation will show that designers, consultants, constructors, fabricators and owners will reap the benefits of a methodology that allows projects to be designed and made better (performatively, functionally, spatially, and aesthetically) for less cost (more efficient, fewer mistakes, accurate pricing, and less time) and / or higher value (better performance providing increased value to the client).

#### 4.4 Contributions to Research

The intention is to provide both designers and fabricators new knowledge for their fields. For designers, this thesis will provide an alternative method in which to communicate their design intentions to the person physically constructing their work. It outlines an example of the design of a fabrication process that can be implemented into an infinite variety of component design situations. At a minimum, the hope is that a designer reading this will at least have a greater appreciation for the person in the shop or in the field that works hard to produce the best quality product but is often stifled through poor communication and misunderstanding.

For the fabricators, the goal of this project is to provide both theoretical and technical information regarding the making of non-traditional, complex parts and components. It outlines the development of the relationship between design and making, the existing and proposed methods of producing, and the importance of evolving the existing paradigm. In terms of technical information, the advantages and disadvantages of new tools are demonstrated and a rich amount of amount of data is provided regarding the production of rapidly generated mass customized concrete units through negative layer fabrication. This data discusses tolerance, assembly, formwork design, reusability, releasability, integrated & secondary connections, material considerations, and the relationship between the design to the tool and the tool to the product.



5.1 Process of Investigation

The underlying basis for this investigation is to create a new methodology for effectively translating design intention into fabrication that can be applied to a wide variety of applications. To facilitate this process the design for the remotely located desert shelters has been utilized to test the proposed theory.

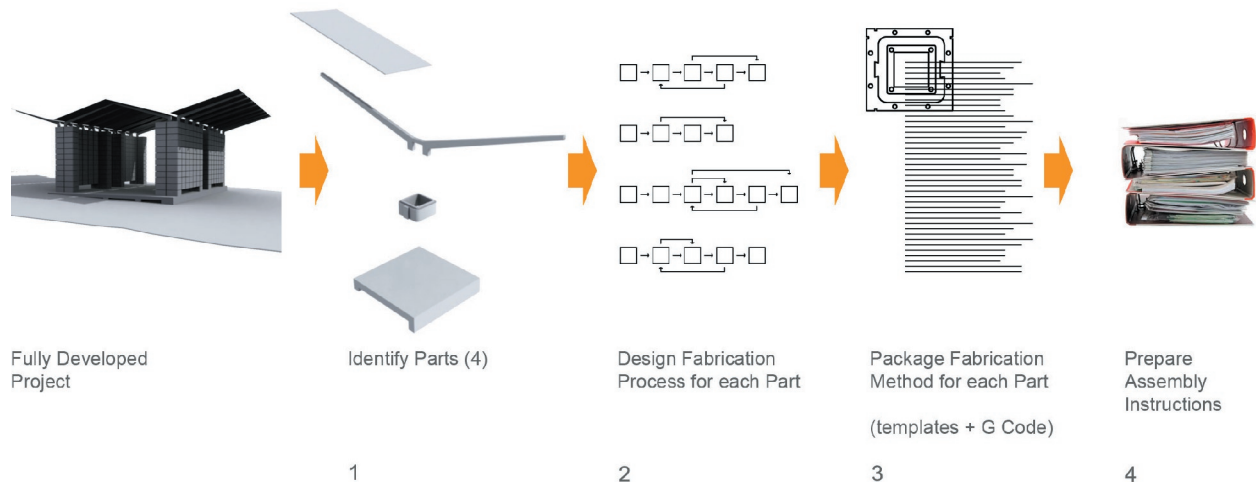

Figure 5.1.A

As illustrated in the above diagram (Fig. 5.1.A) there are a proposed four steps when taking the remotely located desert shelters from a fully developed design to its information for construction.

Step 1 – Determine all parts within the building.

The desert shelters contain 4 major parts for its construction.

1. Mass customizable concrete floor panels
2. Mass customizable concrete wall units
3. Roof trusses
4. Sheet Roofing

Step 2 – Design the fabrication process for each part

These may vary widely depending on the type of part and its material. For example, a metal roof panel would only require the standardized panel itself and a template (or jig depending on complexity) for cutting it to the correct shape and size. In contrast, the design of the concrete wall units would require

an involved process of designing rapidly generated formwork that can produce mass customized concrete wall units.

### Step 3 – Packaging the fabrication method for each part

This step requires identifying and producing the information needed for the means and methods of each part. As mentioned above, a metal roof panel would require a drawing of a template used for cutting (or perhaps a physical template itself). The concrete wall units would require an extensive process of designing a fabrication method and then testing and refining until it has met performance standards. At that point, packaging the concrete wall units may be the GCode (data required for a CNC machine to cut material), a material list and instructions to facilitate the production of the formwork and casting.

### Step 4 – Preparing assembly instructions

Since the means and methods for fabricating each part has now been developed and packaged a set of instructions for carrying out the rest of the assembly needs to be implemented. This set of instructions would merge the material list for each component into a combined bill of materials that could be expanded or reduced depending on the desired design of the desert shelter. Assembly instructions depicting a sequential order of placing and connecting parts would then follow.

## 5.2 Designing the Fabrication Process

To test whether this methodology could be successful this thesis chose to design the fabrication process, package it, and prepare assembly instructions for the mass customizable concrete wall units (Fig. 5.2.B) – the most difficult part of the building.

From the below diagram (Fig. 5.2.C) there are 6 steps when developing the process in which a component will be fabricated assuming that the concept is fully developed and the proposed part is conceptualized.



Figure 5.2.B

### Step A – Familiarization with precedent information

It would be a fairly unlikely scenario in which the method of making something has never been explored and tested in some manner

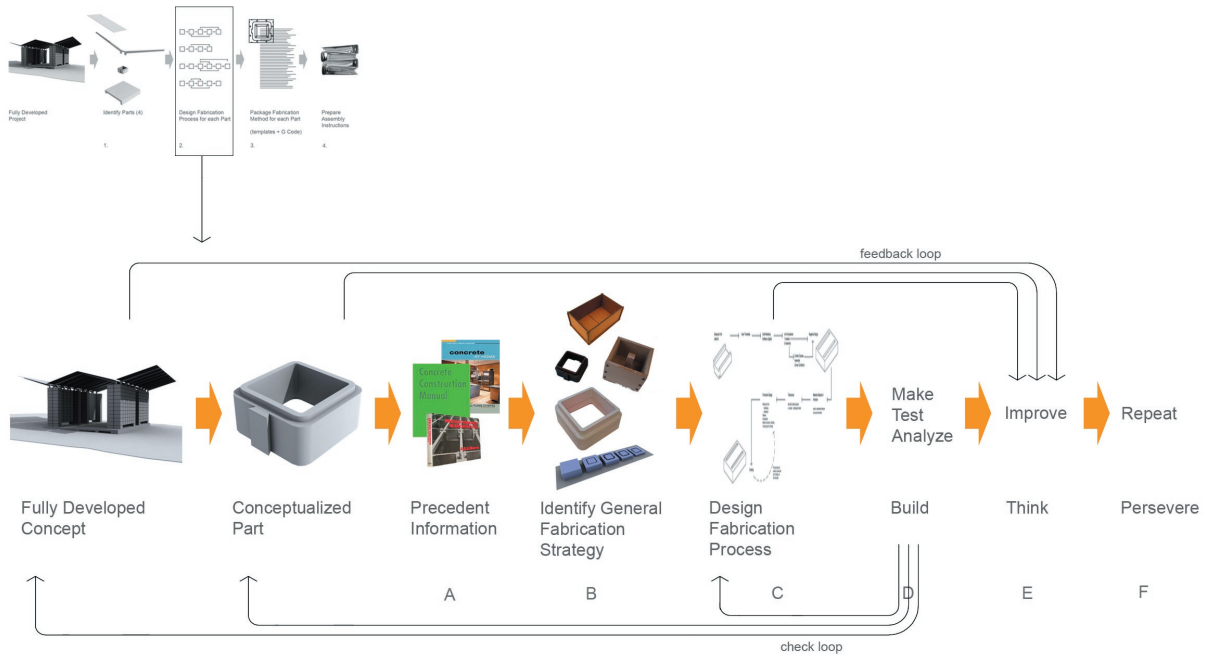

Figure 5.2.C

before. Finding and distilling relevant information from similar work can lead to valuable time saving results.

Investigating precast architectural components and standard masonry block production & construction lead to significant information regarding cost, material mixture, various formwork material characteristics and general fabrication techniques.

The following information was extracted from the precedent investigation.

Castings are created by molds, or the formwork with the negative shape of the desired outcome. Processes can be divided into two main categories, injection molding and free flow molding. Injection molding involves filling a formwork with a casting material under pressure. This guarantees that the material fills the entire mold cavity. Injection molding is a fairly involved process and usually utilized in mass produced precision parts. Free flowing modeling relies on a gravity feed system for filling the formwork. Concrete and plaster are the primary casting materials for this process. Because the material is not forced into the mold under pressure, secondary methods for making sure the entire form is filled and is free of trapped air is utilized.

Molds are defined as formwork that contains a least two or more parts

that allow for an object to be cast and then reused. The two major parts of the mold are called the core and the cavity and permit for the object to be removed. It is important that the formwork be designed in such a way that the desired object does not lock within the mold. Often, draft angles are applied to designs to ease the removal of the cavity; a typical example of this is the design of most tapered shaped trash cans.

Historically, molds have been expensive to design and manufacture. They tend to be used in the creation of mass produced objects. By creating hundreds and sometimes thousands of the same pieces the initial upfront capital cost of production can be spread throughout and make it an economical production process.

Molds are created from a variety of materials and depend on the desired tolerance, cost and reusability of the form. Metal forms are produced from steel, pre-hardened steel, aluminum, and / or beryllium-cooper alloy. A metal form for an architectural component can create between 75 and 750 castings (Morris 1978). Besides cost, another disadvantage of metal molds is the change in material tolerance due to the heating and cooling of the hydration process. For these reasons, wood is a heavily used formwork material. Wood forms are typically only able to achieve 30 castings but because of their lower production cost and resistance to thermal expansion and contraction may be more viable than metal molds. For specialty situations, formworks can also be constructed from fiberglass and rubber.

#### Step B – Identify a general fabrication strategy

With the proposed design of the mass customizable concrete units and background information on casting methods several different ideas for making these blocks were developed. The design of a fabrication strategy can be easily related to the thought process in which any design professional uses by simultaneously weighing advantages and disadvantages and making decisions on empirical, experiential, and pragmatic information.

Three general fabrication strategies were developed for the concrete units.

The first strategy proposed creating steel molds of the negative shape using the core and cavity technique. Traditional 8x8x16 concrete masonry units are cast in a similar process. This method would allow for developing a variation on an existing proven process or in other words, building a better mousetrap. The design challenge set forth

would then look at ways in which these steel molds could be mass customizable and rapidly generated at low cost. (Fig. 5.2.D)

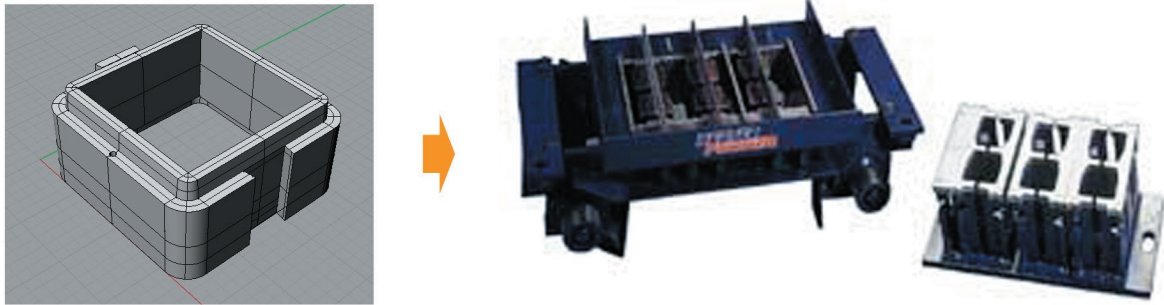

Figure 5.2.D

Upon further developing this method it was quickly discovered that traditional steel molds are expensive, difficult to make and not easy to customize. Since the base characteristics of each method are polar opposites it would be impossible to modify the existing method without creating an entirely new concept.

The second method proposed utilizing polyurethane elastomer rubber. A highly viscose material that when cured produces a flexible rubber form. Because of the elastic qualities of the rubber, complex negative shapes could be formed and castings would 'pop' out of the mold once cured. (Fig. 5.2.E)

This process was explored to some degree. Although early results

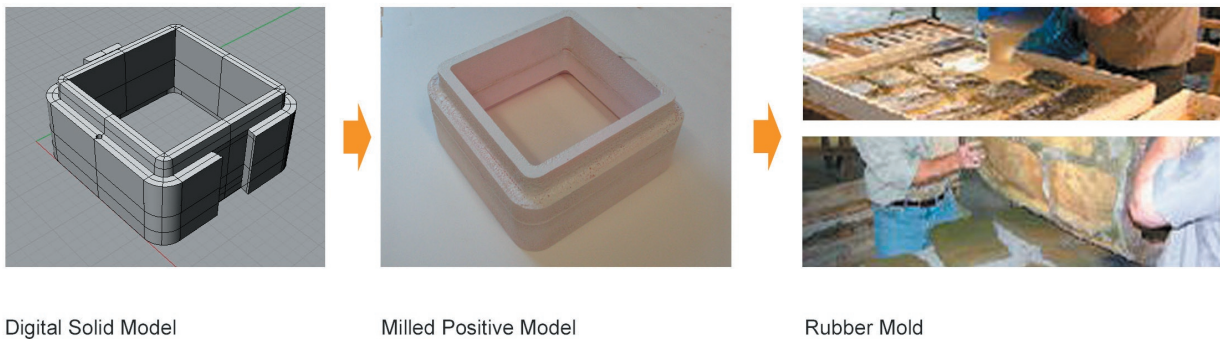

Figure 5.2.E

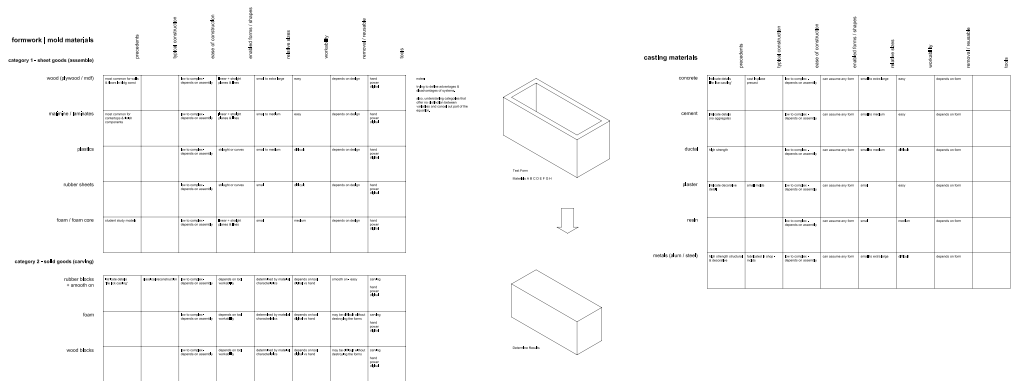

Figure 5.2.F

seemed promising, the long term potential appeared undesirable. This method relied heavily on a proprietary chemical process that was expensive and not readily available to the mass market.

Although the flexible rubber casting method was abandoned, its ability to create complex negative shapes and release casts was intriguing.

It seemed that there must be an alternative method in between the highly rigid steel formworks and chemical rubber molds. Charts were laid out looking at as many formwork materials as possible. These materials were ranked according to their price, availability, workability and conduciveness to casting. (Fig. 5.2.F)

Sheet type materials such as plywood, medium density fiberboard, masonite and acrylic appeared attractive during the analysis. To test the above characteristics a series of small models were created. Since the category of 'conduciveness to casting' was largely hypothesized these casts looked at different materials reaction to cement hydration. (Fig 5.2.G)



Figure 5.2.G

Overall, the sheet materials performed well. However, excessive moisture caused the plywood and masonite to 'bow' along the outward surface or long side of the grain. Upon closer examination, the ends of the material at the grain cross-section did not appear to change

tolerance. From this observation it was decided to explore formworks created entirely from ends of sheet materials. To accommodate the negative mold the sheets materials would be cut and stacked creating the shape of the hollow void for casting. (Fig 5.2.H)

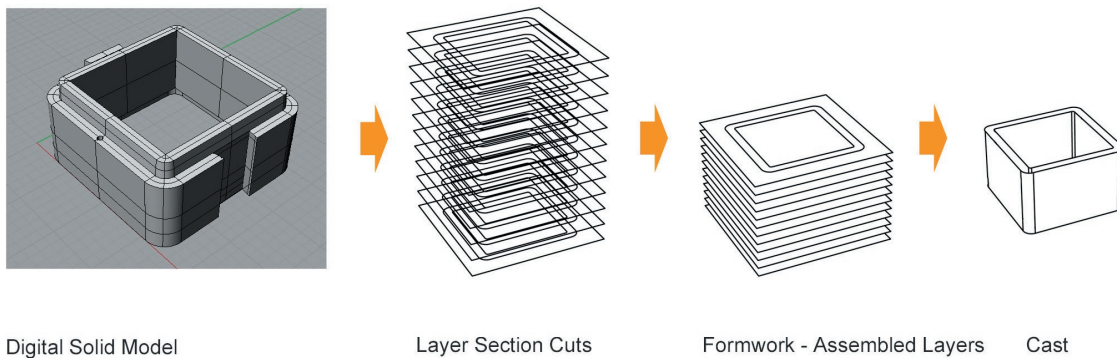

Figure 5.2.H

### Step C – Design the fabrication process

Once the general fabrication strategy has been determined a proposed procedure for the fabrication process will need to be designed.

As evident from the below diagram (Fig. 5.2.I), several factors need to be considered in order to quantify results and assist in critical decision-making.

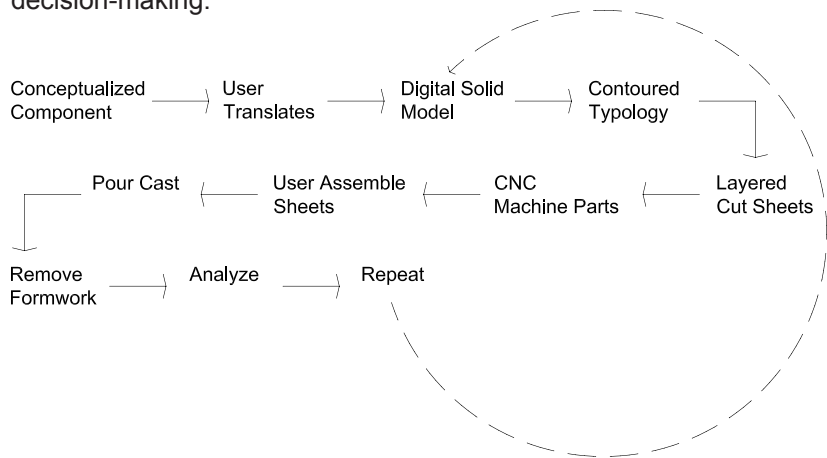

Figure 5.2.I

1. What are the dependent variables?
2. What are the independent variables?
3. What is the target unit cost, directly associated to the amount of time each cast takes?
4. What is the target reusability of each formwork?

The dependent variables become the use of layered formwork that could be entirely constructed from plywood or like material and processed on a numerically controlled machine. The other dependent variable is the use of concrete due to its relative cost, mass understanding, and global availability.

The independent variables are dominated by the shape of the formwork sheets, which determine the ease and difficulty of assembling and disassembling, which in turn directly affects the cost. Other independent variables also included type of connections and methods of assembly. This allows for feedback loops to be established between the design of the component and its relationship to the overall design of the desert relief shelter.

#### Step D – Determine a method of quantifying results

Quantifiable results needed to be definable in order to make effective decisions that lead to the most efficient process.

The following questions were posed to test the success of each experiment.

1. Quality Does the process yield the ability to cast a successful object?
2. Quality What is the resolution of the cast?
3. Efficiency What is the reusability of the formwork?
4. Cost Can materials be used efficiently?
5. Cost What is the speed of casting, removal and reassembly?

The quantifying results or data utilized to determine the success or failure of a given design was the speed in which it could be produced which directly related to its cost. During the experiments three time indicators were set up to measure results. First, the speed at which loose pieces could be matched and assembled into the formwork. Second, the time it took to disassemble the formwork and remove the cast. Last, the time involved to reassemble the formwork for the next casting. The time it took for the CNC machine to cut the pieces as well as for a person to mix the concrete and pour the cast were not monitored because their results depended on the type of equipment utilized and the skill of the laborer, neither of which were directly



effected by the design of the formwork.

#### Step E – Make, Analyze, Improve

After the design process had been fully developed the physical making of the object was critical in order to determine the success of proposed ideas and determine unforeseen issues that were not apparent.

Each cast was produced and then subsequently analyzed. If the cast did not meet the previously set requirements for production, the most problematic area of the design was isolated and a method for improvement was established. Feedback and check loops were also put into place to check decision making against the design of the fabrication process, the conceptualized part and the fully developed concept.

#### Step F - Repeat

This entire process would then be repeated as many times as necessary until consistent casts could be produced that satisfied initially set qualifications.

6.1 Introduction

Step E and F of the component fabrication process lists; Make, Analyze, Improve and Repeat. The intention of the experimentation was to follow these four steps and their previously outlined feedback loops in order to develop the mass customized formwork until it satisfied the qualifications listed.

The following qualifications were outlined as the minimum requirements that the formwork must meet.

Effectiveness – The cast must be of high quality and resolution, achieve a proper strength required for normal construction practices and assemble without difficulty, maintaining connection tolerance.

Efficiency – The formwork must be reusable and fall into the range of commonly acceptable number of iterations. The advantages of mass customization must be comparable in cost to mass production and therefore the formwork & subsequent wall assembly must be assembled and disassembled quickly and comprised of inexpensive materials.

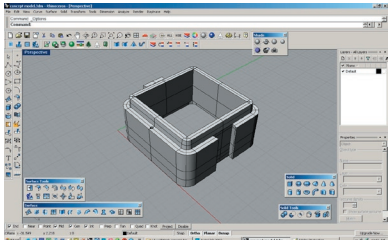

Figure 6.2.A

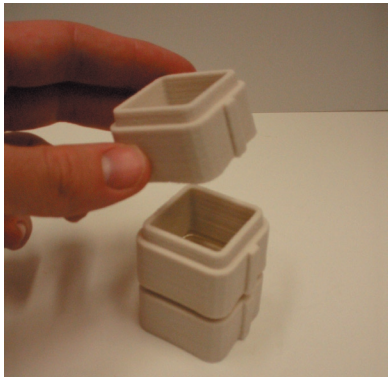

Figure 6.2.B



Figure 6.2.C

6.2 Process

[make]

The process of making each concrete unit would be as follows. First, a digital three dimensional solid model would be drawn in the computer (Fig. 6.2.A). Second, utilizing an additive-layered fabrication machine (a ZCorp ZPrinter machine for these purposes) physical models of the cast would be made.

The first feedback loop was then initialized and the physical model was tested against its initially proposed design and its relationship to the whole, or in this case the rest of the assembly (Fig. 6.2.B).

If the physical plaster model met the requirements set forth by the qualifications, the digital three dimensional solid model was then translated into layers for fabrication sheets. The first fabrication sheets were 1/3 scale models cut from 1/8” masonite on a 120 watt 2 axis laser cutter. The masonite layers (Fig. 6.2.C) were then assembled by



Figure 6.2.D

hand and cast using Rockite cement (Fig. 6.2.D).

[analyze]

Upon removal of the cast from the formwork both objects were sent for their second feedback loop. The cast was tested not only for its initially proposed design and relationship to the assembly but also by the fabrication process by testing its quality. The formwork was also tested by the fabrication process through its ability or inability to make a successful cast, the quality of the cast, its time effectiveness (which leads to cost), and its efficiency or the reusability of the formwork.

[improve]

The element of the analysis which is least successful was then studied and methods in which to improve its performance were designed.

[repeat]

Once a method for improvement had been developed it was redrawn as a digital three dimensional solid model and the process was repeated again. This process took as many times as necessary until the results of the analysis were met or exceeded all qualifications set forth.

### 6.3 Formwork 1

[design]

The anticipated shape of the casting was first constructed in a three-dimensional computer model comprised of closed poly surfaces. Horizontal contour lines were then arrayed throughout the model at the interval of the thickness of the formwork material. These contour lines of the positive model were then extracted and placed onto identical boxes with alignment holes. Partition lines were then added manually to assist in the release of each layer.

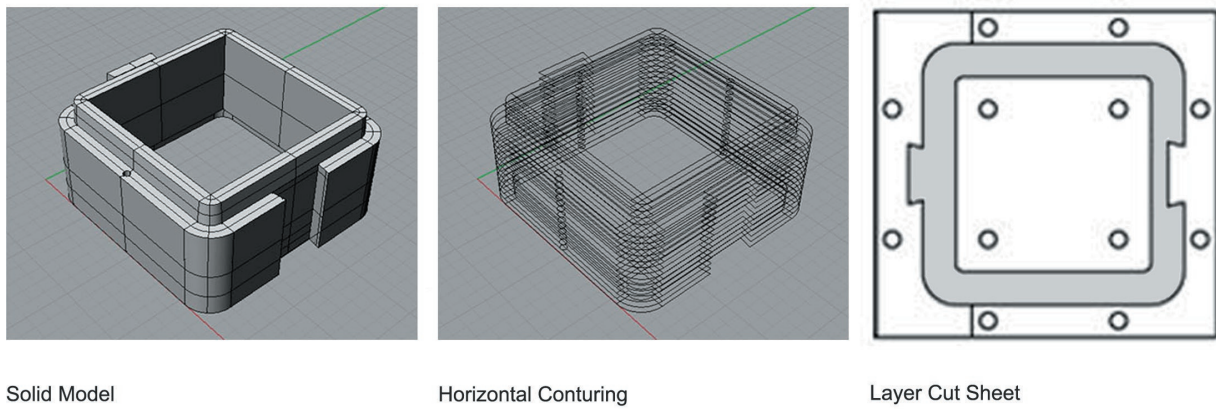
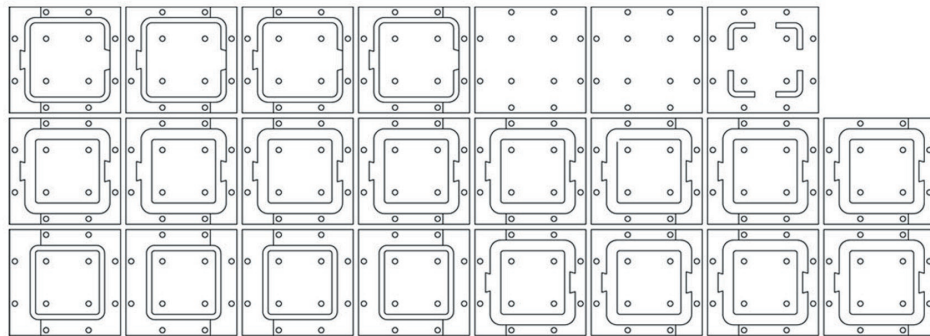

Figure 6.3.A



Full Cut Sheet - Ready for laser cutter

Figure 6.3.B

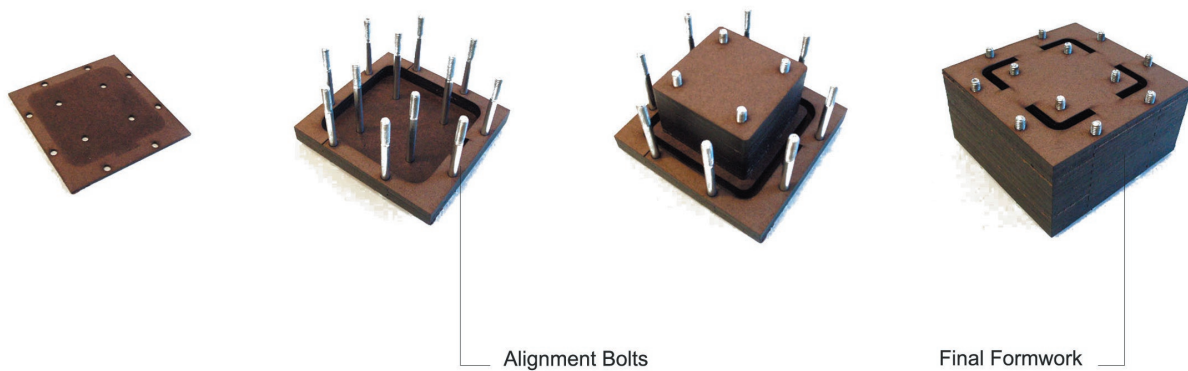

Figure 6.3.C

[model]

The formwork sheets were cut from 1/8" masonite using a 120W 2 axis universal laser cutter. Alignment bolts (1/4") were added to precisely hold the layers together during casting.

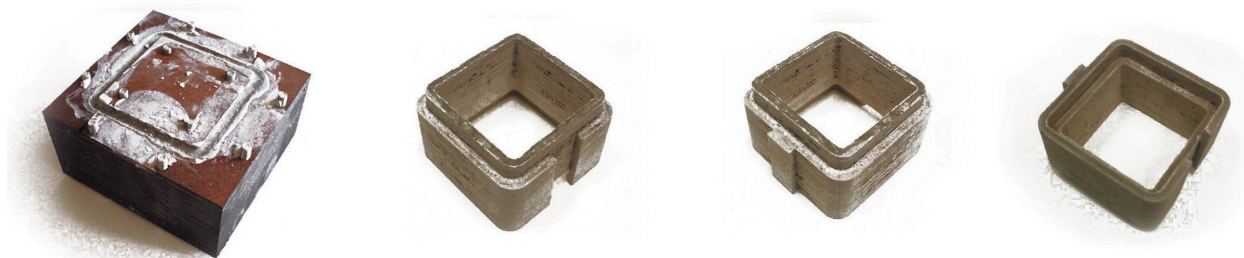

Figure 6.3.D

[procedure]

The cast was performed using Rockite Cement mix. Due to the relative thinness of the walls a low aggregate material with a high rate of viscosity was required.

[results]

1. Overall, the first cast utilizing negative layer fabrication

proved to be extremely successful in terms of its accuracy, tolerance, efficiency and resolution.

2. However, the release of the individual layers proved to be somewhat difficult in terms of 'sticking' and 'locking' and the interior section had to be drilled out for its removal.
3. Splitting the ring layers into half pieces with partition lines was helpful but problems existed primarily around the integrated dovetail connectors.

Initial Assembly	38 minutes
Disassembly and Cast Removal	51 minutes
Formwork Reassembly	24 minutes

[design]

The primary purpose of the design modifications was to first increase the effectiveness of the layer removals by making sure pieces could be removed quickly with ease and without damage. Second, methods for increasing the speed of assembling and disassembling in order to decrease the amount of human effort required was critical to make the formwork a cost viable option.

The computer model was edited and a draft angle was added to the interior to assist in the removal of those layers. The digital model was then contoured and added to the cut sheets in the same method as Formwork 1.

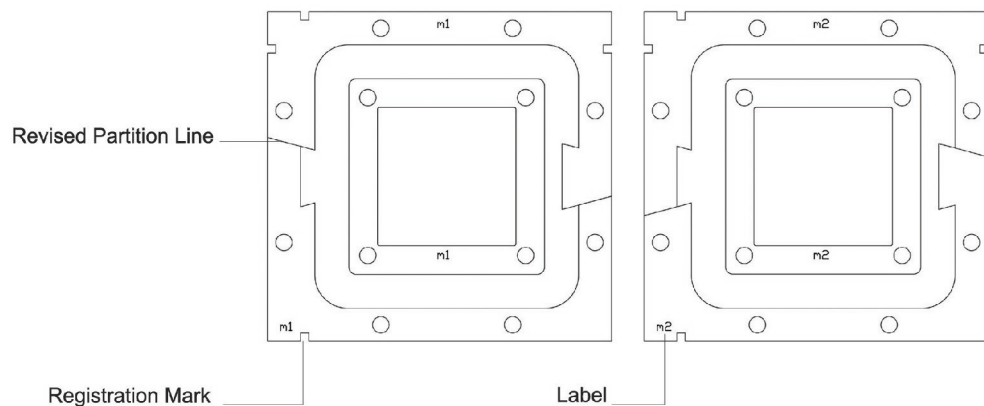

Figure 6.4.A

[model]

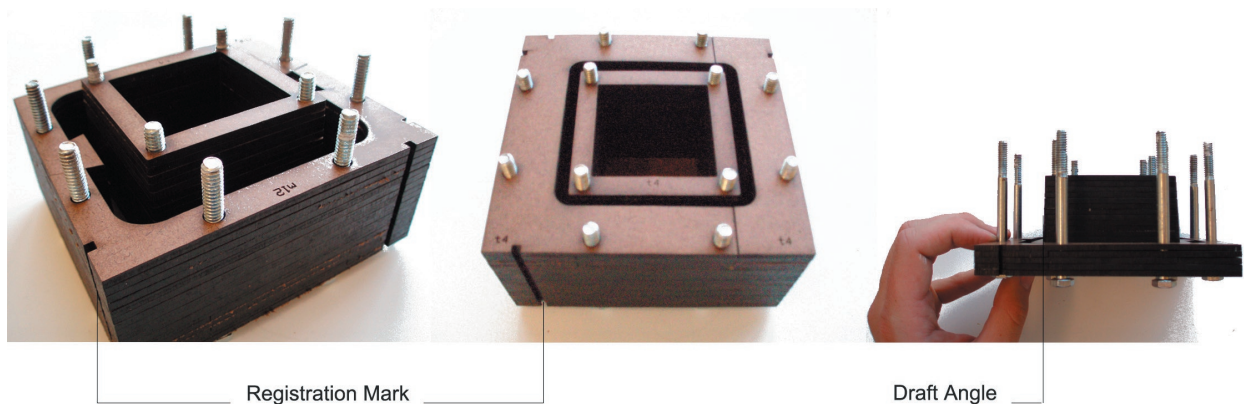

Figure 6.4.B

Formwork sheets were labeled and registration marks were added to assist the assembly and disassembly time. Also, the partition lines were altered to break the rings at the point of the integrated connections.

[procedure]

Labeling each layer by its typology (base, bottom layers, middle layer, top layers & top) and number (distinguishing alternating partition lines) drastically improved assembly time. Pieces could be quickly arranged by their type and then ordered by their number. The registration marks quickly verified that the layer was rotated in the correction direction. Casting again occurred with Rockite Cement with a high rate of viscosity. After setting for approximately 1 hour the pins were slid out and the layers removed.

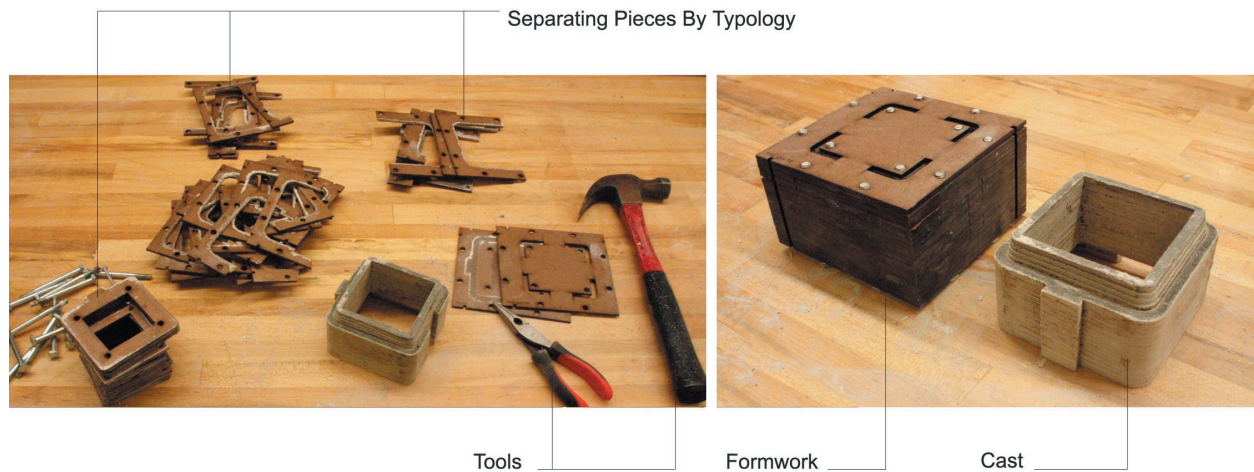

Figure 6.4.C  
[results]

1. The new partition lines located at the integrated dovetail connections was an improvement but still did not provide the desired ease and speed.
2. Providing a draft angle and hollowing the interior layers was much more effective. They could be removed without damage.
3. Although ease of removal and speed of assembly and disassembly was improved it seemed apparent that more improvements could be made.

Initial Assembly	19 minutes
Disassembly and Cast Removal	14 minutes
Formwork Reassembly	12 minutes



## 6.5 Formwork 3

[design]

After the results of Formwork 2 the main concern was to layout the layers in such a way that they would essentially “fall off” when being removed from the cast. The female dovetail integrated connection proved to be the most difficult section of layers to remove. Various layout concepts of the partition lines were drawn and analyzed.

Up until this point every formwork was a one time only cast. Another intention of this formwork was to see how many casts could be executed before the model broke down to the point beyond reusability.

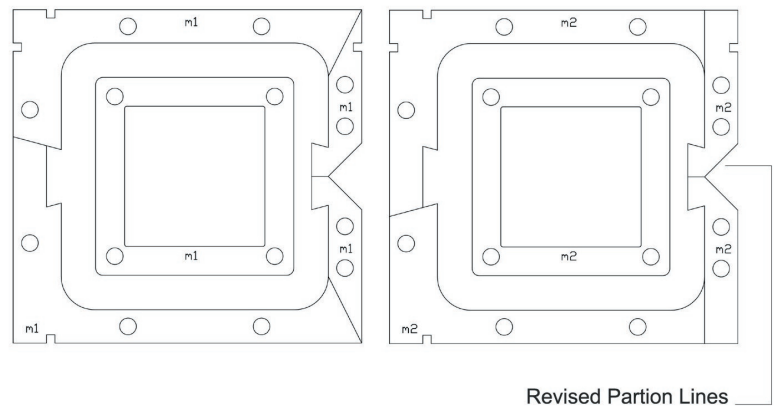
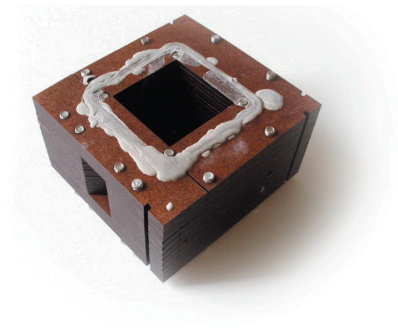

Figure 6.5.A

[model]



Formwork Cast 1

Figure 6.5.B

The same formwork cut sheets from Formwork 2 were utilized with the labels and registration marks. However, the partition lines were edited and subdivided at the integrated connections as shown.

[procedure]

Increasing each layer from 3 parts to 5 parts also increased the amount of time required for assembly. The model formwork was assembled, cast and disassembled 3 times.

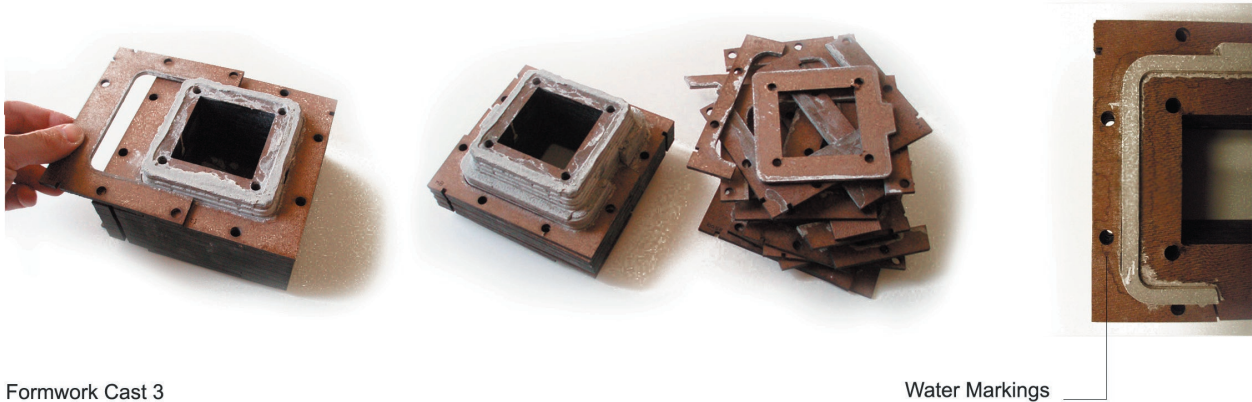

Formwork Cast 3

Water Markings

Figure 6.5.C

[results]

1. Although increasing the number of pieces in each layer increased the assembly time this was overcome by the increased efficiency in removing the formwork from the casting and proved to be successful.
2. The first 2 castings with the formwork proved successful. However, by the third casting the masonite had started to break down and weaken. This caused an increased “sticking” between the formwork and cast. Although this information was useful it was difficult to determine the long term viability because the actual anticipated formwork material was to be 1/2” plywood.

Initial Assembly	23 minutes
Disassembly and Cast Removal	7 minutes
Formwork Reassembly	14 minutes

## 6.6 Formwork 4

[design]

After realizing that 3 castings per formwork would not offer a viable solution for mass customized rapidly generated formwork alternative materials were selected as possible design explorations.

Acrylic was chosen for its ability to resist water penetration and availability in sheet product form.

[model]

The model was constructed from 1/8" acrylic sheets utilizing the same formwork cut sheets from Formwork 3. The amount of acrylic required is approximately 10 times the cost when compared to



1/8" Acrylic

Figure 6.6.A



Cast Broken During Layer Removal

Figure 6.6.B

masonite. Cutting the formwork sheets also required more time when compared to masonite because the laser cutter needed to make 3 full passes per sheet in lieu of just 1 with masonite.

[procedure]

Although the model was assembled in the same way as previous formworks, more care had to be taken because of the brittleness of the material and its ability to easily crack. Again, the model was cast with Rockite and set for about an hour.

[results]

1. Because of the density of the material, if the layers were not heavily compressed together concrete was able to slide in between layers locking the formwork & cast together as well as decreasing the resolution of the finished casting.
2. The brittleness also became problematic during cast removal. Its inability to flex made it difficult to remove pieces without breaking them. It also became apparent that the 4 sided units were weaker in the corners.
3. Although the acrylic is nearly impenetrable to water its density and brittleness & cost disadvantages far outweigh its usefulness as a possible formwork material and therefore was decided to no longer peruse it.

Initial Assembly	35 minutes
Disassembly and Cast Removal	28 minutes
Formwork Reassembly	26 minutes

Since the negative layer fabrication had yielded some success it was decided to initiate all feedback loops in the fabrication process diagram. Several critical design decisions were made.

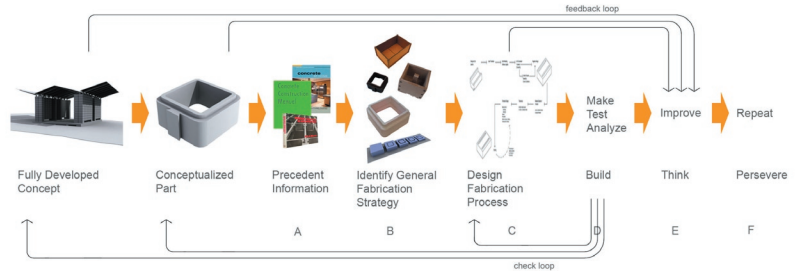

Figure 6.7.A

First, it was realized that the 4-sided tube profile might not be the ideal shape for several reasons. Four sided objects have an inherent instability due to high amounts of moment forces in the corners when shear and lateral stresses are applied (See Formwork 4 Results). Also, when several blocks were assembled together it was difficult to achieve an air and moisture tight seal between them without an additional material such as mortar or silicon due to the slight variations in the concrete finish.

Next, although dovetail connections are commonly used method of joining 2 pieces of wood together it does not translate well to concrete. Concrete at small scales does not make acute angles very well because of its lack of tensile strength. Also, the expansion and shrinking during the hydration process causes minuet variations in the tolerance which make tight uniform connections difficult to achieve.

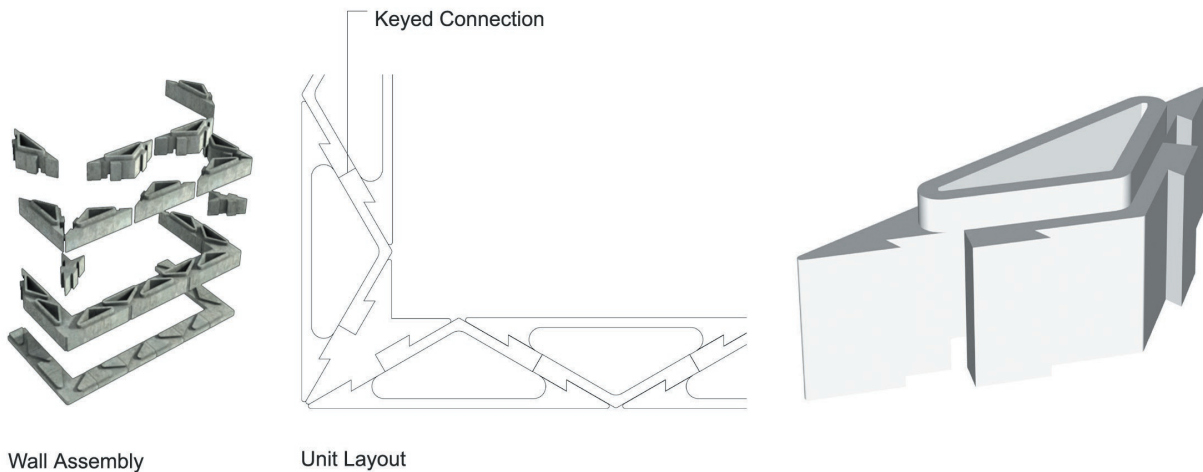
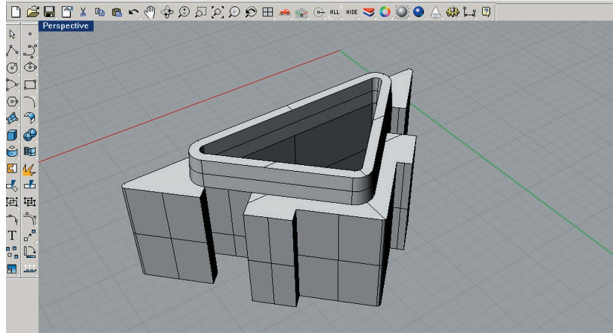
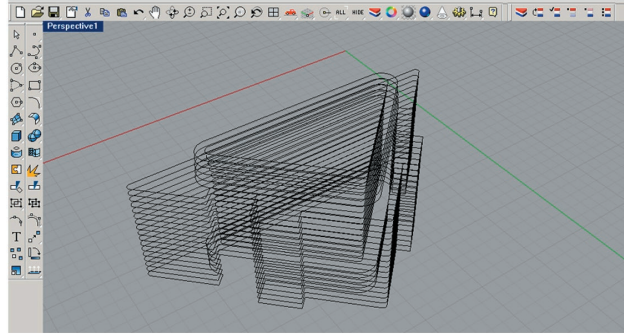

Figure 6.7.B



Solid Digital Model



Extracted Contour Profiles

Figure 6.7.C

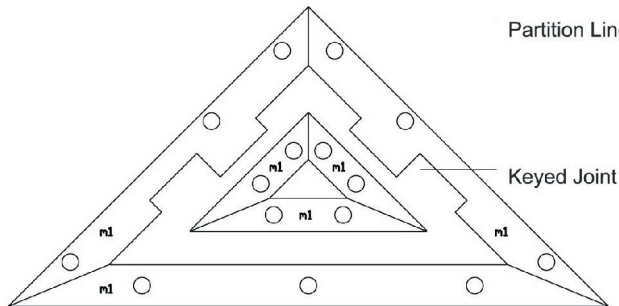

Pattern A

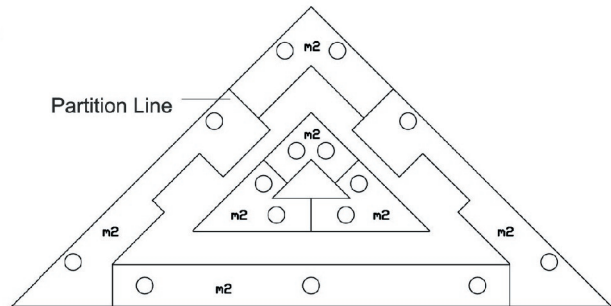

Pattern B

Figure 6.7.D

For the above reasons triangular shaped unit blocks with keyed connections where designed and analyzed. Triangle shapes where thought to be much more stable and when used in a alternating pattern could provide a better-sealed enclosure. Keyed connections where hypothesized to be much easier to cast and assemble then dovetail connections and would provide a “locked assembly” due to their angled geometry and redundancy of units.

[model]

A positive 3 dimensional computer model was constructed and the contoured profiles extracted.

[procedure]

Formwork cut sheets were laid out and partition lines where added in a similar manner to previous models. The method of casting was similar to previous casts.

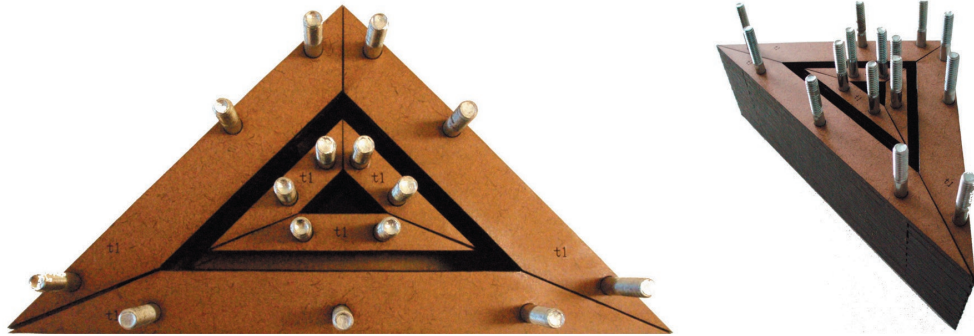
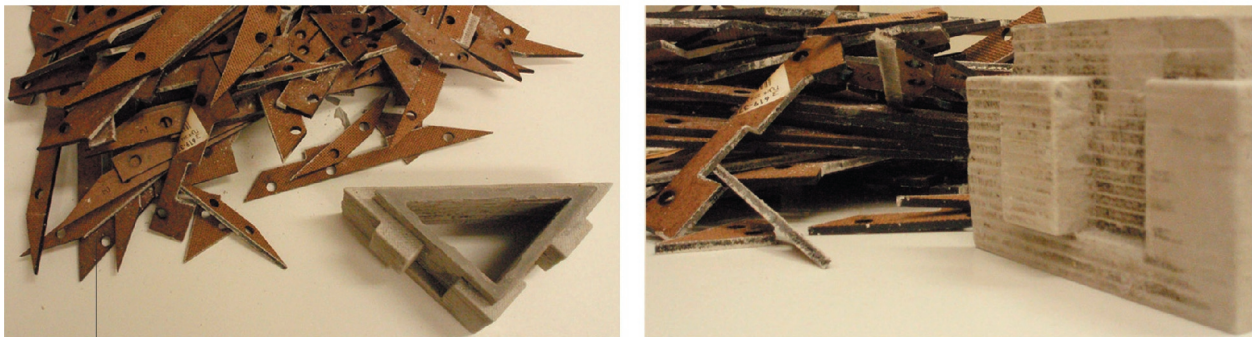

Figure 6.7.E



Nearing an Overwhelming Amount of Pieces

Figure 6.7.F

[results]

1. The triangular shaped unit block appeared to be substantially stronger than the 4 sided tube shape.
2. The square keyed connections were nearly effortless to remove when compared to the dovetail connects and drastically increased cast removal speed.
3. The major obstacle in the formwork design still seemed to be the number of pieces that had to be worked with in order to assemble & disassemble a single cast (currently 140) and the amount of time required to manage that many individual parts.

Initial Assembly	16 minutes
Disassembly and Cast Removal	9 minutes
Formwork Reassembly	10 minutes

[design]

The primary intention of the next formwork design was to design a way in which the amount of human time required for each cast could be drastically reduced.

It became apparent that looking at other industries in the business of fabricating multi piece parts was necessary. For example, the automotive industry assembles automobiles from large modules such as the drive train, cockpit, and instrument panel. All of these modules are comprised of thousands of pieces.

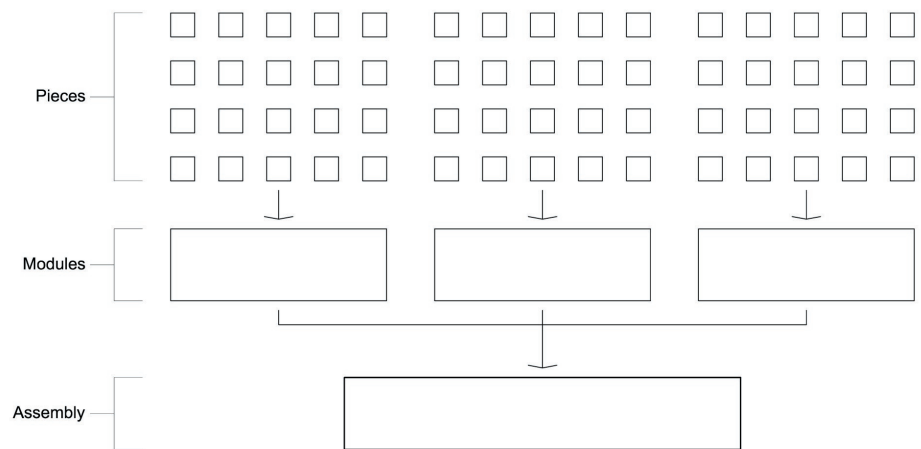

Figure 6.8.A

If a similar methodology could be employed, like pieces from various layers would be combined into larger components. Hence, the 3 sides of the exterior layers were combined as units to reduce their total number of pieces from sixty to three.

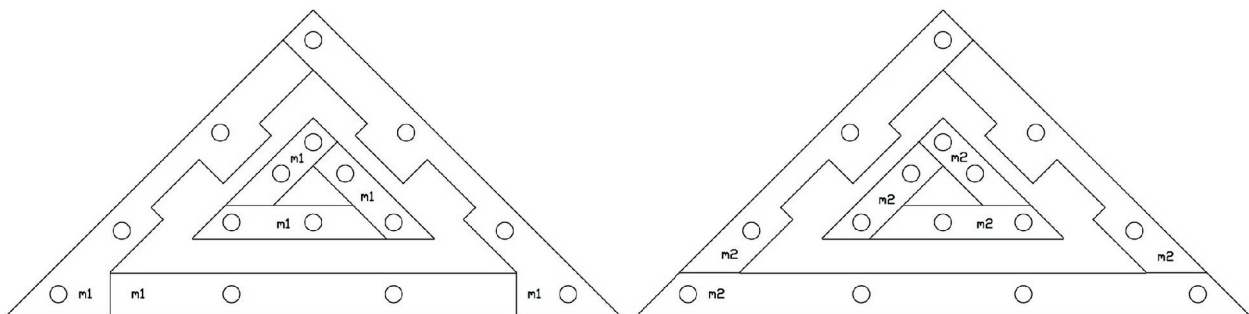
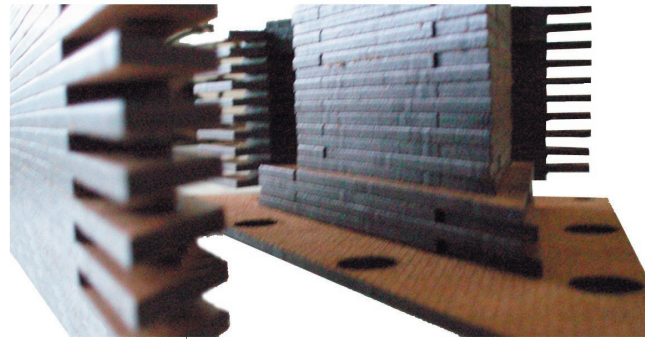
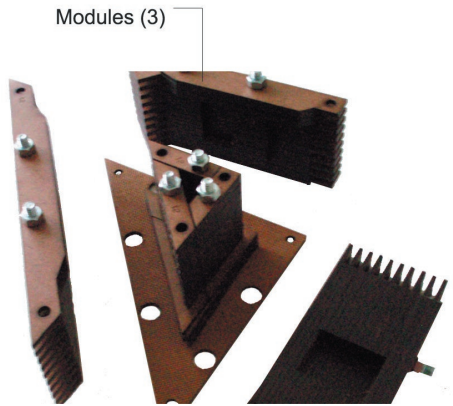

Figure 6.8.B





Finger Joint with Alignment Bolt Hole

Figure 6.8.C

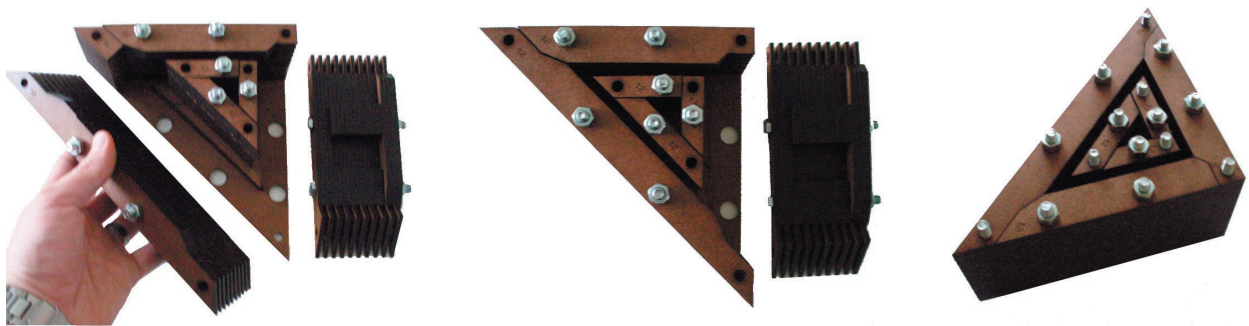
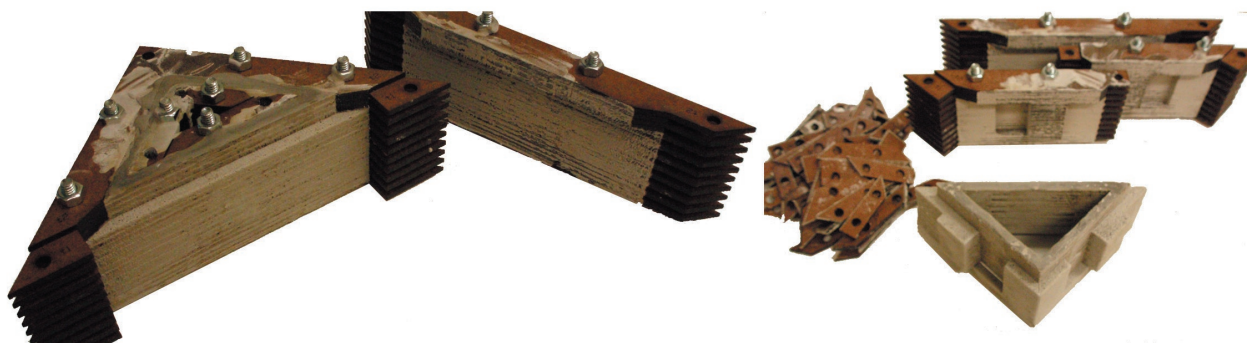

Figure 6.8.D



Drastic Reduction of Pieces for Assembly / Disassembly

Figure 6.8.E



Figure 6.8.F

[model]

The layers were cut from the same formwork cut sheets utilized in Formwork 5. However, the base plate was modified to allow mid section pin connections to become isolated and corner point pin connections to attach to the base plate. In the current design, the interior layers revolved around in a draft angle spiral pattern making it impossible to employ the same methodology of combining pieces into modules. For the purpose of this experiment it was deemed time effective to leave the interior layers as is and test the new hypothesis on the exterior layers only.

[procedure]

Casting occurred exactly the same as in previous experiments. The model set for approximately an hour before the sides and interior layers were removed.

[results]

1. Making 3 modules from 60 individual pieces because extremely successful. Although the initial assembly time remained relatively the same the disassembly and reassembly times were drastically cut.
2. It was observed that on the 2 sides where the keyed connections existed the forms needed to be pulled perpendicular from the cast.
3. Assembling and disassembling the individual pieces of the interior layers now became by far the most time consuming part of the casting process.

Initial Assembly	18 minutes
Disassembly and Cast Removal	4 minutes
Formwork Reassembly	6 minutes

[design]

Although the connections from unit to unit had been highly developed in computer modeling and fabrication method, the connection had yet to be fully tested physically. Likewise, it had always been considered that the unit designs would be mass customizable but again the implications involved were never fully tested in model form.

The purpose of the next experiment became to design a corner wall condition and provide an increased spread footing for foundation loading.

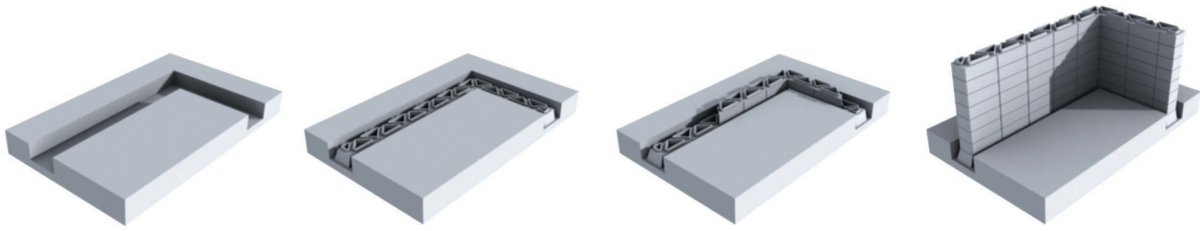

Figure 6.9.A

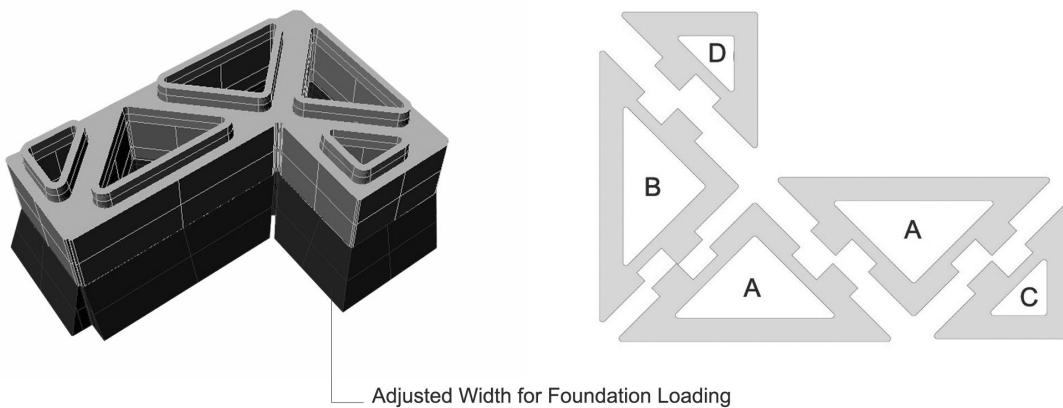

Figure 6.9.B

[model]

Eight unit block designs were developed in three-dimensional computer modeling software. Their tolerances, method of assembling, and interference checking were all performed before cut sheet layouts began. Each unit was then contoured and laid out onto fabrication cut sheets.



Assembling Forms

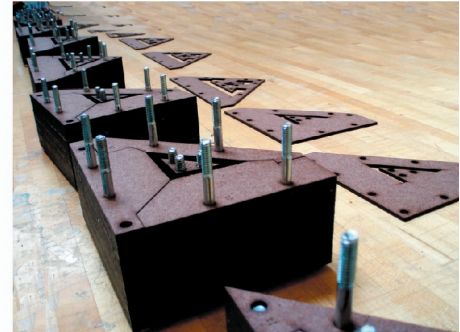

Ready for Casting

Figure 6.9.C

[procedure]

Six formworks were cast once and 2 were cast twice for a total of 10 units. By performing all of the cutting, assembling forms and casting all of the tasks were grouped together and efficiency was increased.

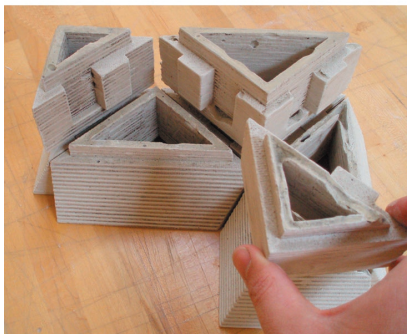

Joint Tolerance Between Units Was Not Achieved



Units Did Not Slide Together as Anticipated



Figure 6.9.D

1. The ability to make mass customized units worked well. By automating the process of contouring computer models there was little chance of human error to occur between the three dimensional models and the fabrication sheets. Automated processes will easily perform the same task on 10 different models or 10 identical models with the same results unlike humans who perform repetitive tasks much better and are more likely to make errors or decrease production time when dealing with unique conditions.
2. It became quickly obvious that the tolerance between a concrete to concrete connection was much different than that of a wood to wood connection. As discussed earlier, the expansion and shrinking caused during the hydration process changes the tolerance of the finished surface. Unlike wood, it was nearly impossible to achieve a line of zero tolerance and some method of controlling the joint sizes would need to be implemented. As evident from the images, none of the casts were able to fit together with the desired tolerance.

Initial Assembly	15 minutes
Disassembly and Cast Removal	8 minutes
Formwork Reassembly	10 minutes

6.10 Formwork 8

[design]

Realizing that a major oversight had taken place in the inability to forecast the tolerance between concrete to concrete connections, it was decided next to start production on a full scale unit to determine any potentially unforeseen conflicts.

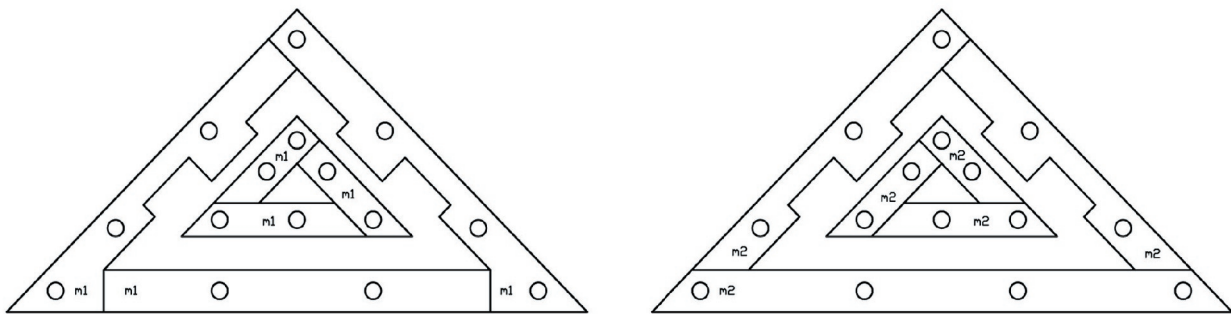

Full Size Cut Sheets

Figure 6.10.A

[model]

Utilizing the same methods employed throughout the process a computer model was developed at full scale and contoured for 1/2" plywood sheets. Because of the differences between a laser cutter using a laser beam on a two-axis gantry and a numerically controlled router using an 1/8" cutting bit on a three axis gantry, the formwork cut sheets needed to be altered. All cut lines needed to have a minimum

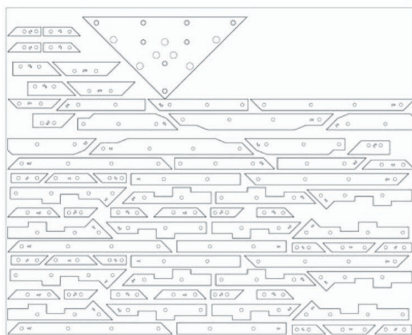

Tool Paths



CNC Machine Cutting Layers

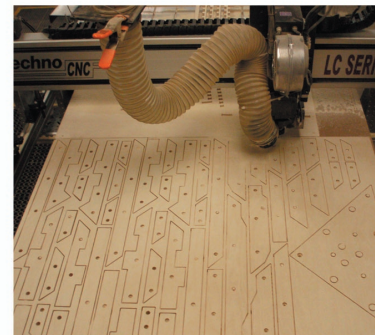
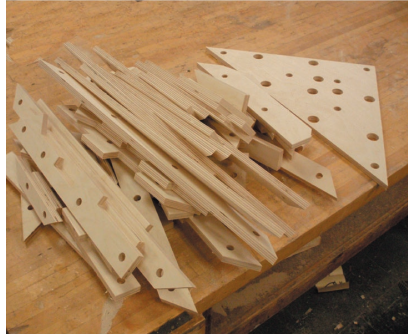
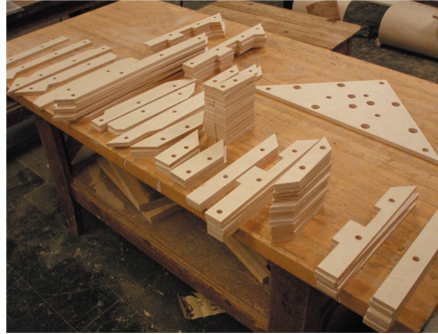

Figure 6.10.B

distance of 3/8" between them to accommodate the tool path and the pieces needed to be laid out entirely on one sheet of plywood to avoid time consuming material changing during the process.



Pieces



Sets

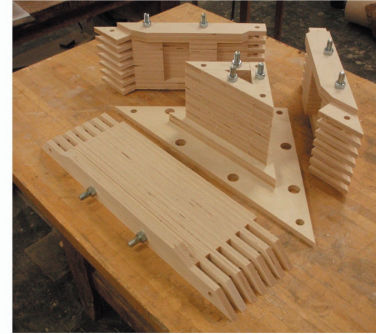

Modules

Figure 6.10.C



Final Formwork Prior to Casting

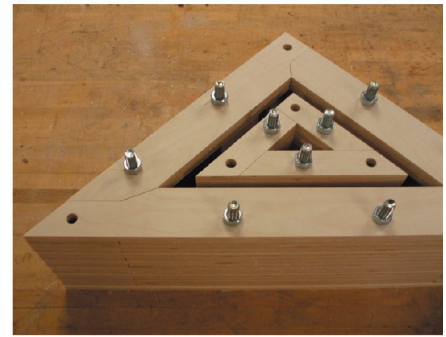
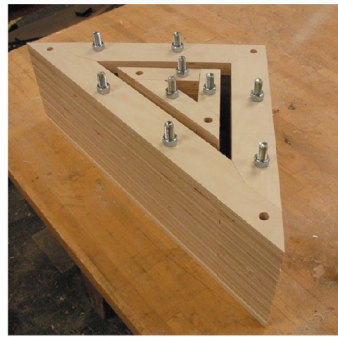

Figure 6.10.D  
[procedure]

Rapid Set cement was used for the casting due to its small aggregate size and quick setting time.

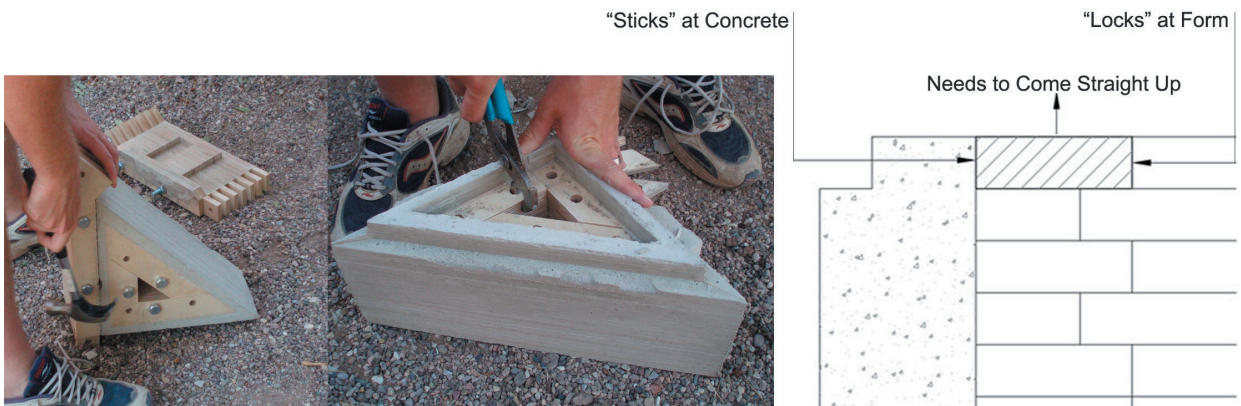

Figure 6.10.E



Concrete Formwork with Exterior Formwork Removed

Figure 6.10.F



Removing Exterior

Interior Layers "Lock" into Place and are Unable to be Removed

Figure 6.10.G



1. Assembling the formwork was easier at full scale than in 1/3 model scale due to working with larger parts more conducive to the size of the human hand.
2. The exterior modules released from the form as easily as it had in the model scale.
3. The interior pieces did not release well in the full scale form. After further examination it appeared that increasing the scale to 1/2" thicknesses "locked" the pieces into place making them nearly impossible to remove without applying a directly vertical force.
4. It also appeared that the expansion of the concrete during the hydration process helped to push outward and assist on the removal of the exterior modules had caused negative effects on the interior layers by forcing the pieces tighter together and therefore making it increasingly difficult to remove.
5. The reusability of the formwork was also to be tested at full scale. Since the interior would not remove each cast was destroyed in order to continue testing. A total of 8 casts were performed on this form and absolutely no signs of deterioration or break down existed.

Initial Assembly	14 minutes
Disassembly and Cast Removal	7 minutes (exterior modules only)
Formwork Reassembly	10 minutes

[design]

The results of Formwork 7 & 8 showed that two variables needed to be worked out for the next experiment. First and foremost, the interior layers needed to be removed with ease and without damage at full scale. They also needed to be combined from pieces into modules in the same way as the exterior of the form in order to reduce time and increase efficiency. Finally, a parametric equation for determining the joint size between units needed to be developed and tested at difference scales.

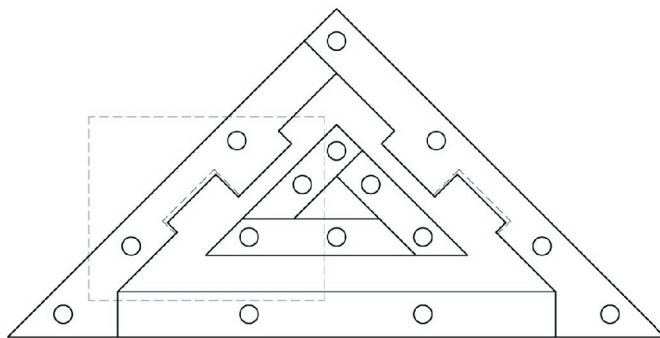

Concrete to Concrete Connection Tolerance  
 Offset 1 =  $L1 / 16$     Offset 2 =  $L2 / 16$     Offset 3 =  $(L3 / 2) / 16$

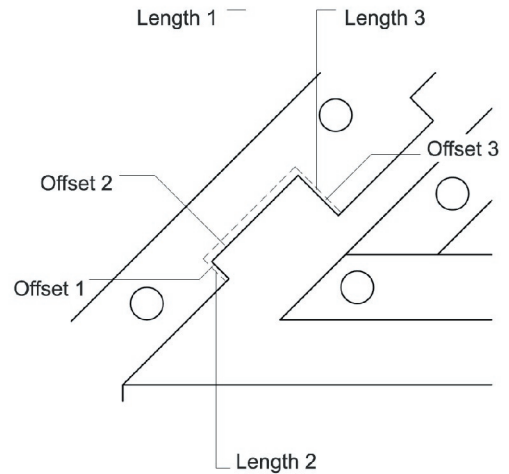
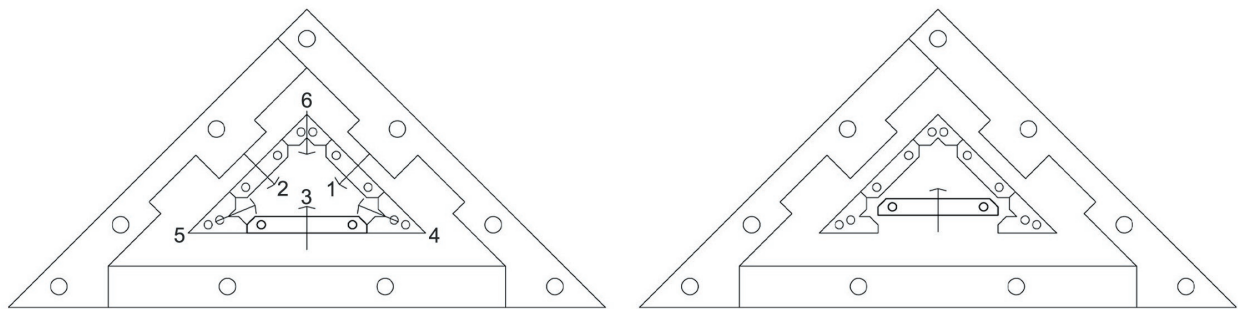

Figure 6.11.A



Order of Disassembly 1-6

Figure 6.11.B

[model]

The interior layers were subdivided into six interlocking sections. A sequential method for removing the modules without interference from other parts was digitally modeled and tested. Concurrently, an equation for reducing the size of the male keyed connection was developed and the computer model edited.

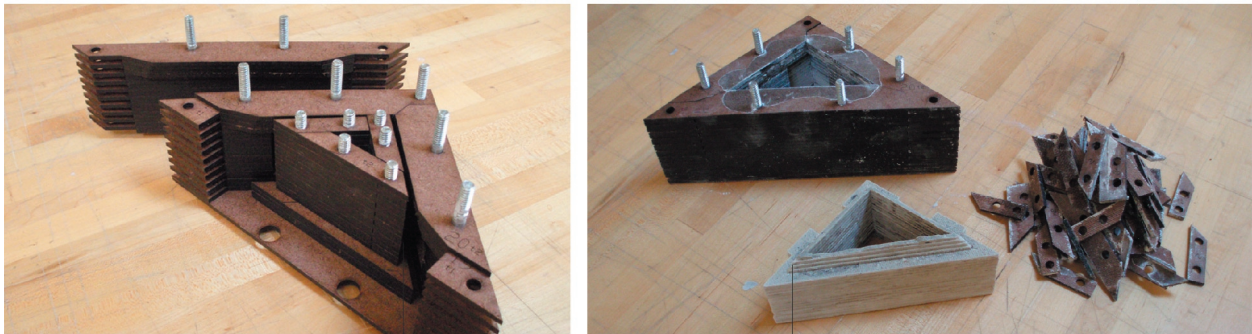

Draft Angle for Vertical Connection

Figure 6.11.C

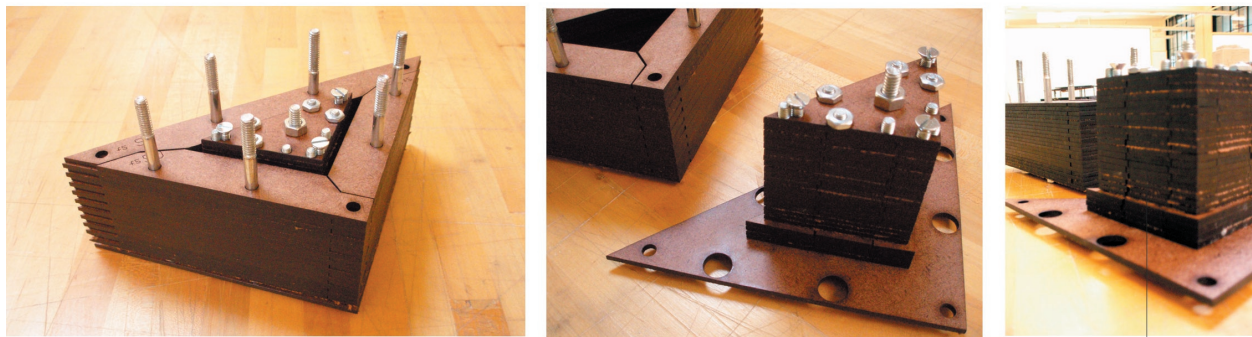

Interior Modules

Figure 6.11.D

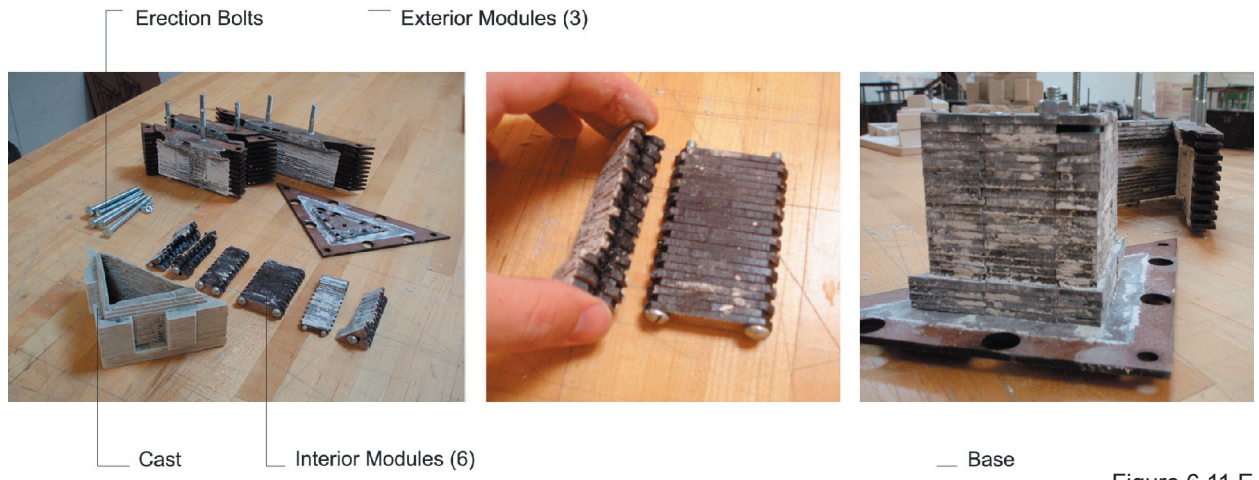

Figure 6.11.E  
[procedure]

Three casts of the formwork were conducted in order to test both the horizontal and vertical connections of the units.

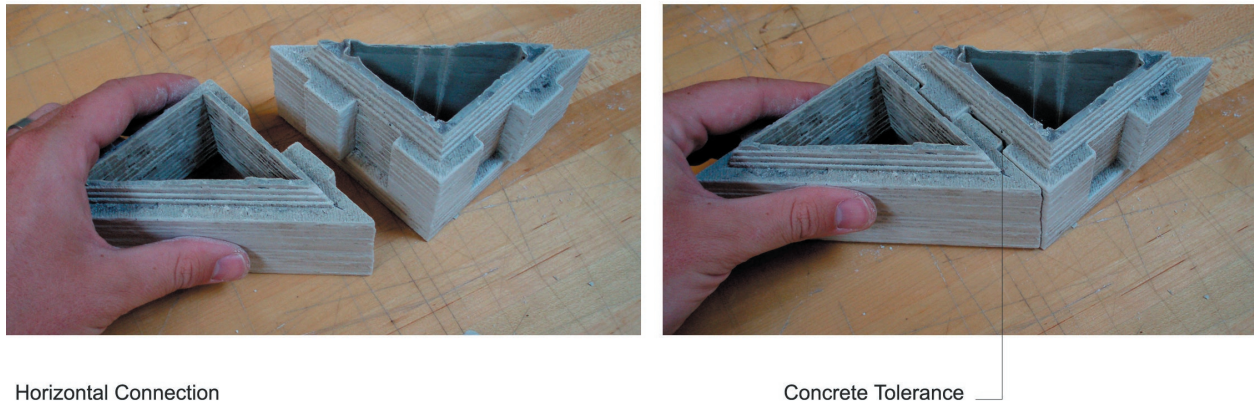

Figure 6.11.F

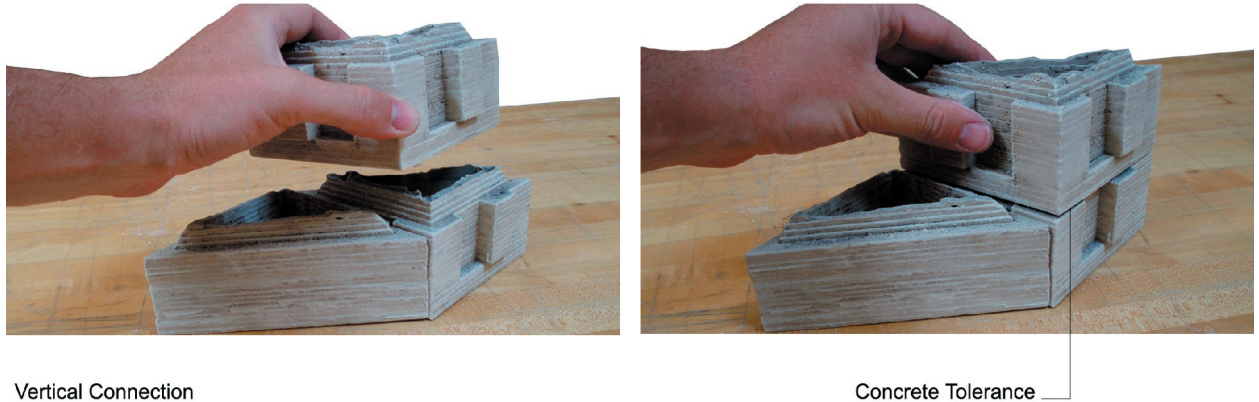

Figure 6.11.G

1. The new design for the interior modules worked excellently and a formwork that could be quickly assembled and disassembled with ease and without damage was beginning to be realized.
2. The tolerance between concrete connections was also equally as successful. The three-unit 1/3 scale model showed promise in its accuracy, levelness, and stability with combined units.

Initial Assembly	19 minutes
Disassembly and Cast Removal	5 minutes
Formwork Reassembly	10 minutes

## 6.12 Formwork 10

[design]

A full scale formwork and cast needed to be successfully rendered based on the results from the previous experiments.

[model]

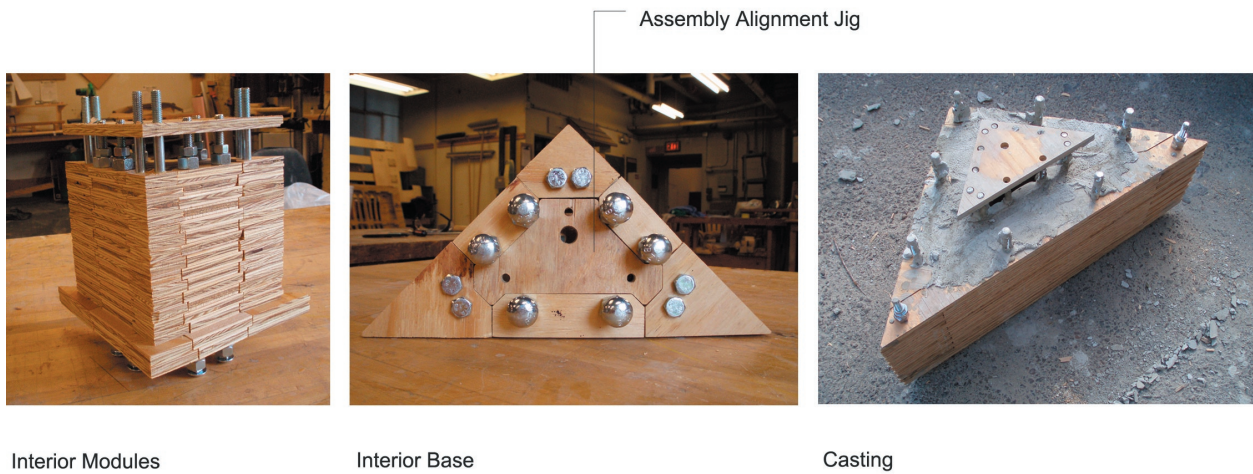

Figure 6.12.A

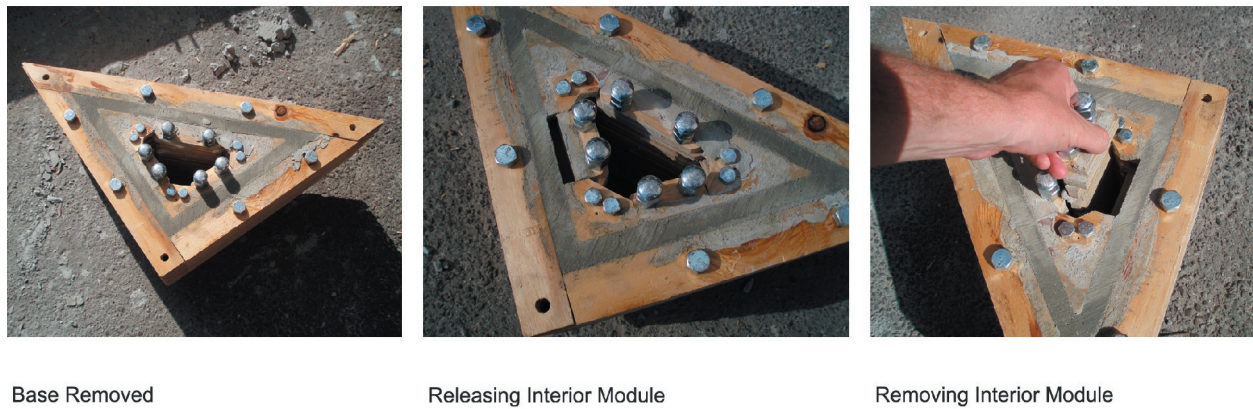
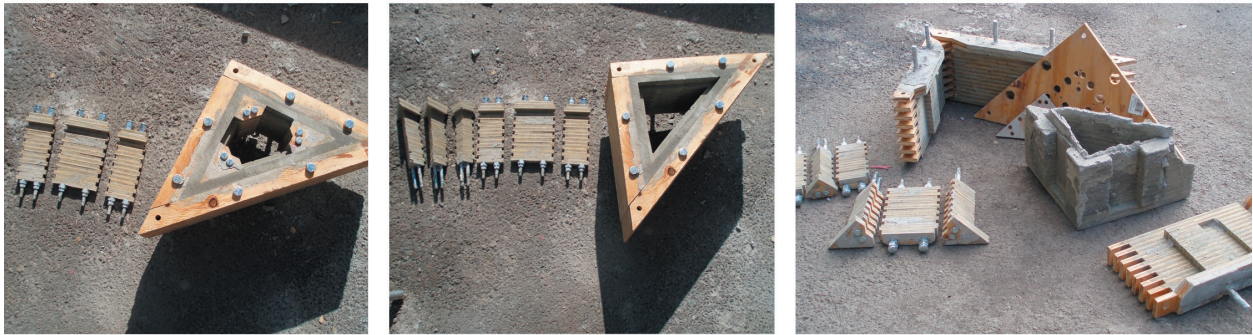

Figure 6.12.B

[procedure]

The full scale model was constructed from  $\frac{1}{2}$ " plywood and cast with low aggregate quick setting cement. On the day of the casting the weather was particularly hot and humid in Cambridge, MA. This caused the concrete to not pour with the same viscosity as previous casts and towards the end of the pour had to be "packed" in.



Interior Modules Removed

Full Formwork Removed

Figure 6.12.C

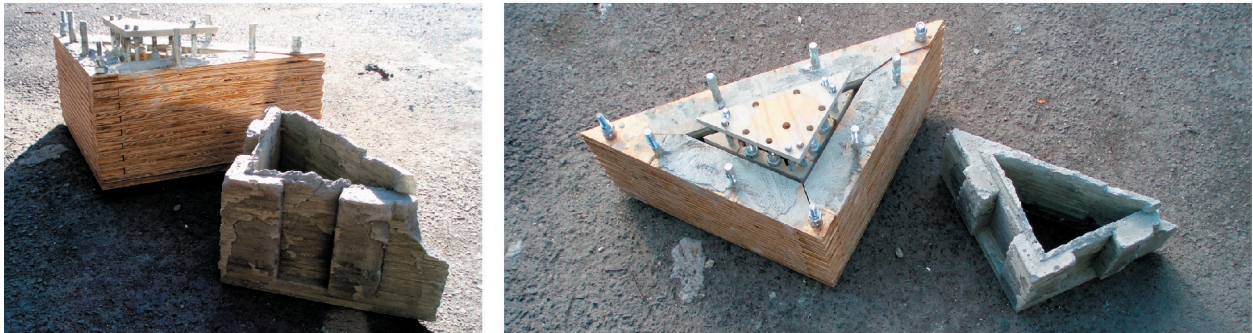

Figure 6.12.D

[results]

1. Just like the 1/3 scale model the full size cast released exceptionally well.
2. The cast did not contain as high of resolution as hoped but it is believed this was due to the pouring problems explained above.

Initial Assembly	14 minutes
Disassembly and Cast Removal	6 minutes
Formwork Reassembly	8 minutes

### 6.13 Formwork 11

[design]

The purpose of the final design experiment was to test the connection of full-scale units in an assembly. To facilitate this, formworks were constructed for a full mid section wall unit and an end block unit. The same sheet layout used for Formwork 10 was utilized and the end block was translated from the digital solid model to a similar layout sheet.

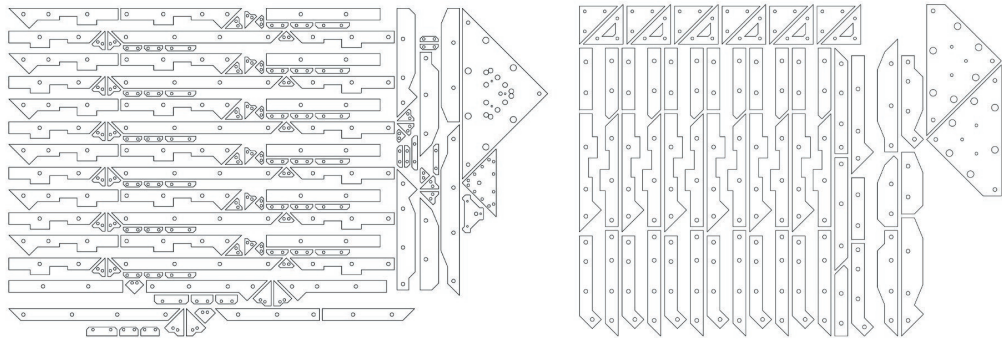

Full Block Cut Sheet

End Block CUT Sheet

Figure 6.13.A

[model]

The assembly of the formworks occurred as anticipated from the experience of previous molds.

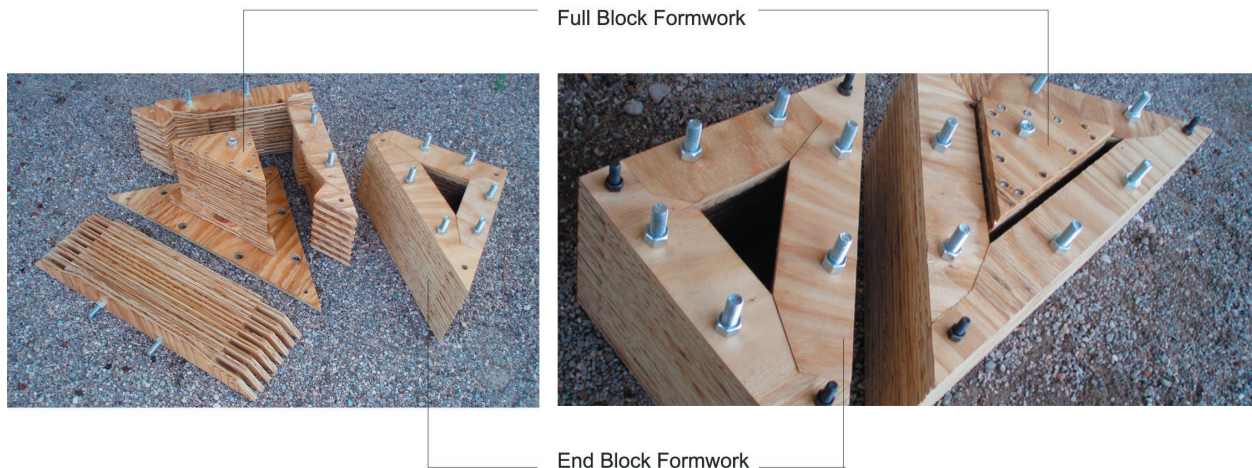
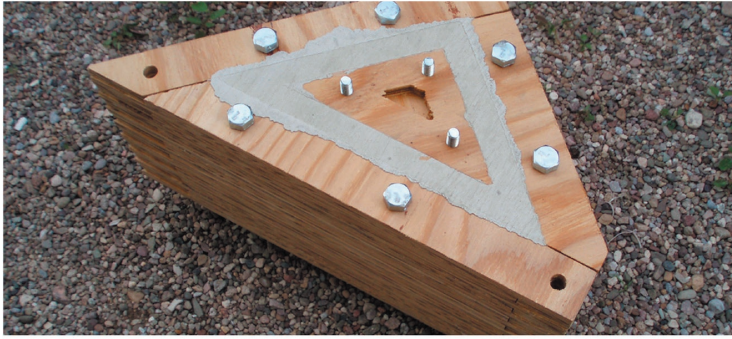

Figure 6.13.B





Removing Formwork

Figure 6.13.C

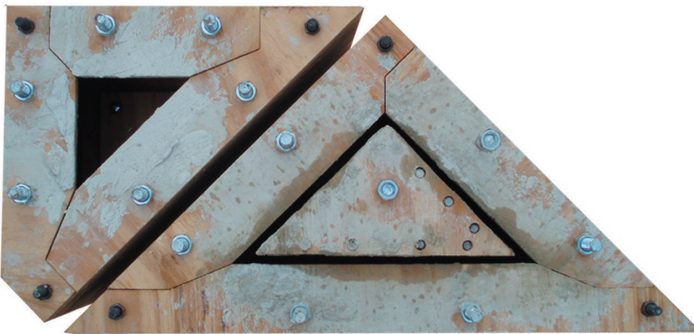

Formworks after 1st Cast

Figure 6.13.D

[procedure]

Each unit was cast using Rapid Set cement and left to harden. The formworks where then removed from the cast easily and assembled together illustrating successful connections of unit to unit assembly.



Casting

Figure 6.13.E



Removing Interior Modules

Figure 6.13.F

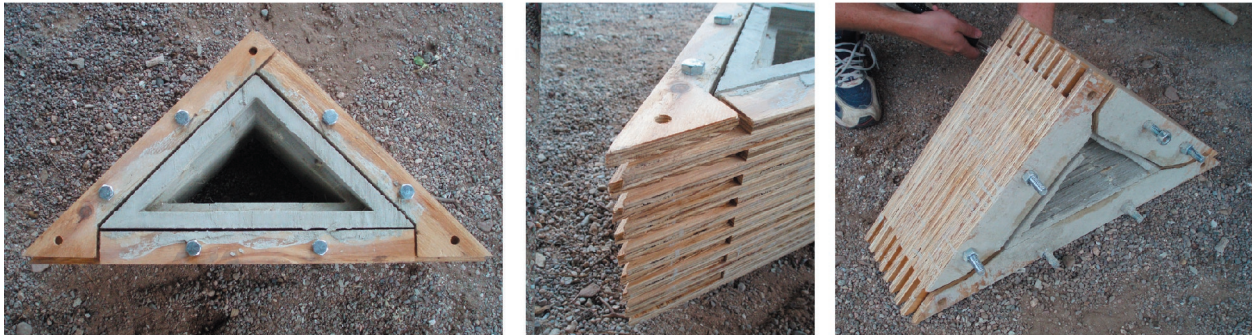

Releasing Exterior Modules

Figure 6.13.G



Removing Exterior Modules

Figure 6.13.H



End Block & Full Mid Block

Snug Corner to Corner Tolerance

Figure 6.13.I

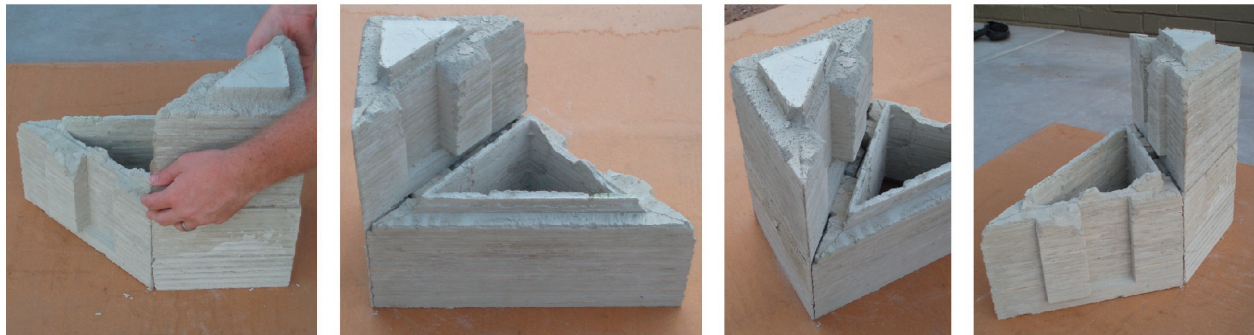

Assembly Level 2 Units

Figure 6.13.J



Full Scale Assembly - Horizontal & Vertical Connections

Figure 6.13.K

[results]

Initial Assembly	12 minutes
Disassembly and Cast Removal	4 minutes
Formwork Reassembly	6 minutes

## 6.14 Transferring Design Information

[packaging the fabrication method]

Now that the formwork & cast have met all of the qualifications set forth it can be packaged as the means & methods of its fabrication. Subsequently each remaining part within the desert shelters would also be packaged in a similar manner and combined.

The packaging of each of the mass customizable concrete unit fabrication designs would be as follows.

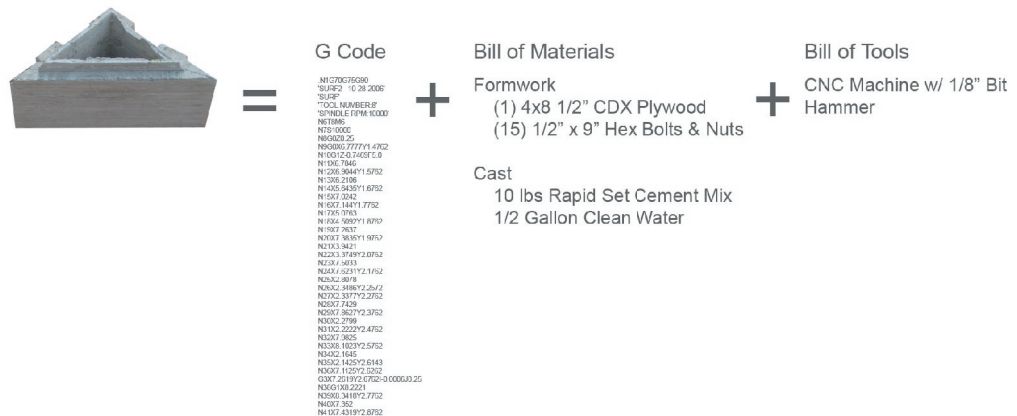

Figure 6.14.A

[assembly Instructions]

Once all 4 parts of the desert shelter have been packaged a set of instructions that sequentially illustrates the step by step procedure for assembling all of the parts should be produced.

The contents of the assembly instructions would be as follows:

1. Diagram of the proposed finish structure for reference
2. Part quantities and a list of all required materials
3. Site preparation information
4. Sequential assembly instructions starting with the mass customized floor panels, to the mass customized wall units, the roof trusses and roof sheeting.

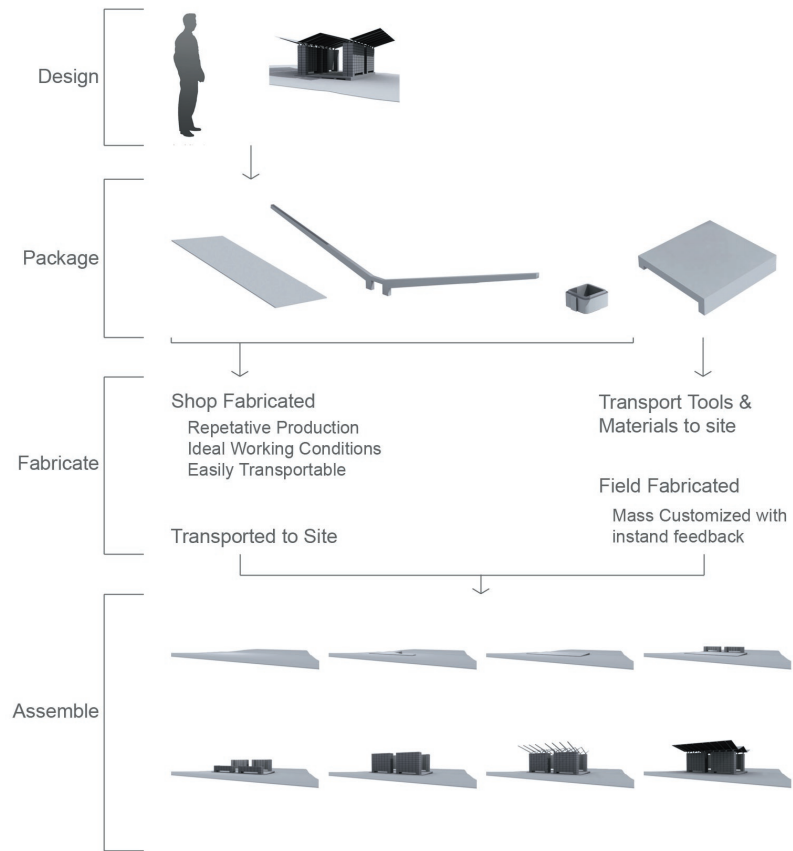

Figure 6.14.B

7.1 Summary of Formwork Experiments

Overall, the process of translating the initial design concept to its method of fabrication was a huge success in that the initial goal of designing the fabrication process from a predetermined object was achieved. However, the process to finally develop a successful unit took much longer than expected and resonated the reason why innovation in the building industry is slow to evolve.

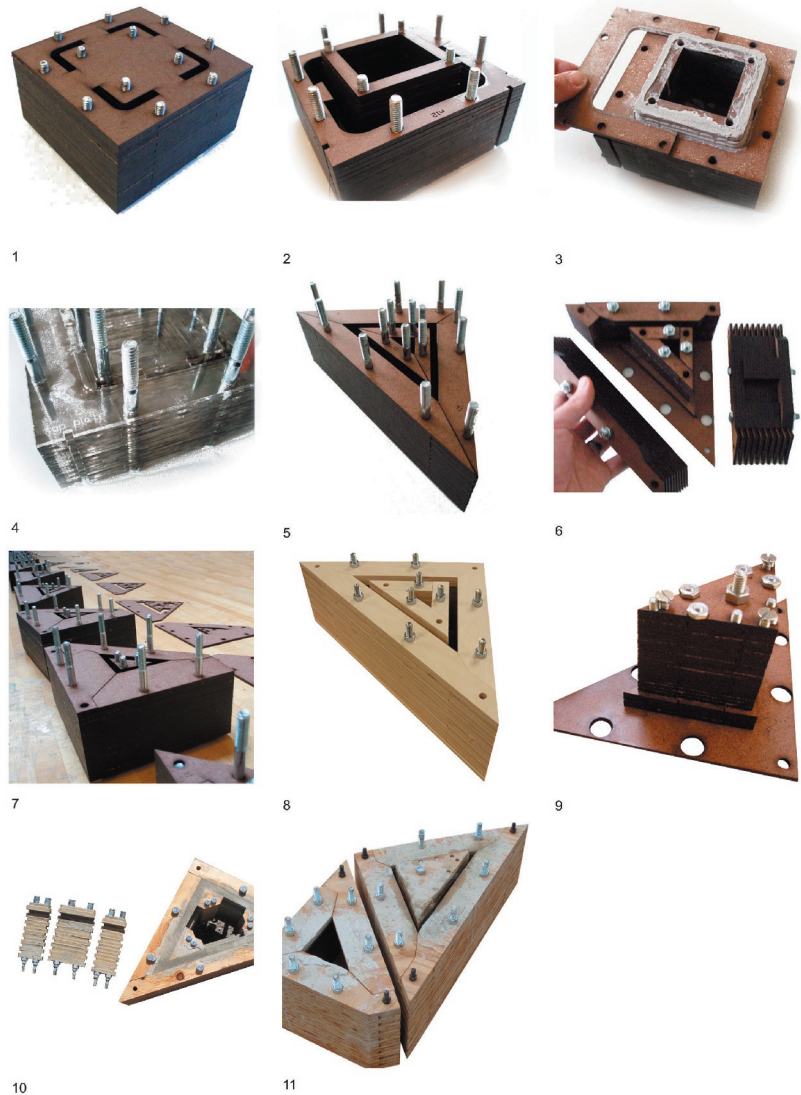

Figure 7.1.A

The results of the experiments are summarized by the 3 categories for each trial, design, models and procedure.

'Design freely, develop methodically.' Designers tend to process a vast amount of ideas and information in their minds and use a variety of influences to determine conclusions. On the other hand, researchers prefer to set up specific problems, test and extract results. The ability to operate in both capacities should not be taken lightly. It is imperative to know when to search for outside the box ideas and when to constrain independent variables to define definitive results.

Solid modeling and extracting topographical contour information through an automated process proved to be an efficient, effective, and consistent method of deriving the layout for the formwork cut sheets. It is almost guaranteed that without automating this process, user error would have occurred at some point during the process and would not have been realized until the model was being assembled.

It is easy to get caught up in the specific design of a part but it's important to always relate design decisions back to the whole. For instance, the first 6 formwork designs concentrated almost entirely on the design of the mold. In experiment 7, 10 casts were produced only to find out that not a single one fit together with the desired tolerance. If the design of the formwork related back to its assembly, two units would have been tested for connection much earlier in the process.

As stated before, theorizing about assemblies and tolerance is just that, theorizing. Physical modeling is absolutely imperative to the successful development of any component and fabrication design. It became apparent that the act of physically making something and studying its results yielded far more information than have could ever been hypothesized.

Models at one scale do not always translate exactly to the next. For instance, the interior layers in the 1/3 scale masonite models released easily all the way through. It wasn't until that same process was applied to the full scale unit that the problem became apparent. The change in scale changed the workable tolerance of the part and rendered the interior layers 'locked' into position. This variance would have been impossible to forecast at the model scale.

It is critical to really analyze the models and look beyond the obvious. The amount of expansion caused by the concrete during hydration



was indiscernible to the human eye but the fact that the interior layers were consistently being locked together was undeniable. Once the justification was discovered the characteristics of the material helped to design the formwork.

[procedure]

If you design freely, the procedure becomes the methodical process for evaluation. Even with an exploratory design the testing needs to reveal a finite solution. For this project it was quantifying the various time expenditures for different parts of the model. (Fig. 7.1.B)

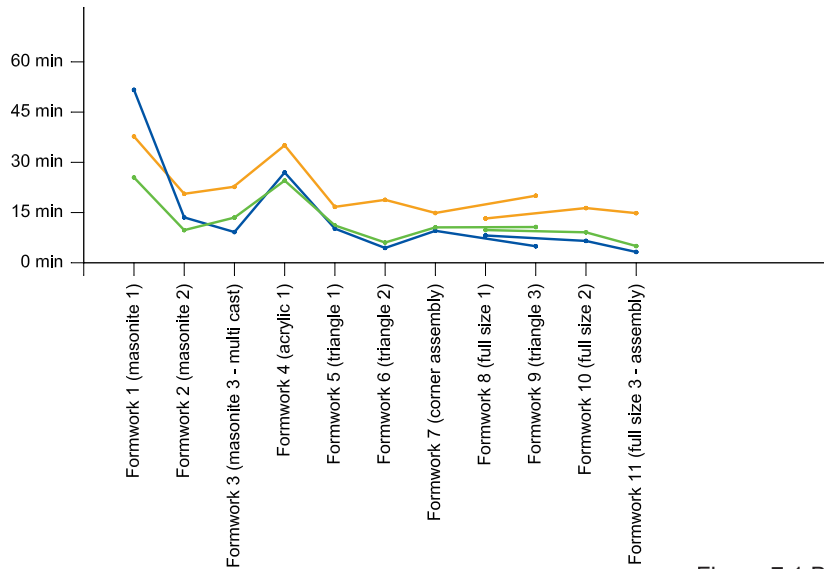

Figure 7.1.B

The yellow line represents the initial assembly of the pieces after they've been cut and removed from the CNC machine. This fluctuated depending on the number of pieces involved, although the full scale models were easier because the size of the parts are related closer to the human hand. Disassembling times of the formwork is indicated by the blue line. This time was greatly reduced when the number of parts was reduced by combining adjacent pieces into modules. The final line, green, represents the amount of time required to reassemble the formwork. It closely followed the blue line and was also related to the amount of parts being worked with.

[future explorations]

Formwork from negative layer fabrication provides an array of potentially new ways to make and build. Because of the ability to codify design information and reduce it to computer data, designers now have the capability to transmit design information anywhere in the

globe without having to rely on skilled labor to interpret. Therefore, designs for entire buildings could be distilled into binary information, emailed thousands of miles, produced on a CNC machine and assembled.

The rapid and accurate production of formwork could also be used for creating other architectural components including concrete countertops and sinks, custom lintels and caps or an infinite possibility of mid scale cast products.

This process also lends itself to projects in remote locations in which it would be economical to move the fabrication of parts from a shop to onsite. When the weight of concrete blocks is problematic this process would allow fabricators to transport a small CNC machine, plywood & bags of cement to isolated project sites. By utilizing on site water, the heaviest material is shifted from the shop to the site.

Although labor costs in the United States are high and materials are relatively inexpensive the inverse is true for a lot of other countries in the world. The efficient use of materials allowed by shaping each unit to its least amount of material required could easily offset increased labor expended by creating a high variety of mass customized parts.

It is the hope that the use of formwork from negative layer fabrication will not be limited entirely to concrete and architectural functions. This process could be applied to nanotechnology by digitally cutting microscopic layers and creating formwork for micro casting of electronic parts.

[continued work]

The successfulness of this process developed during this investigation has prompted others to explore it as a possible method for creating formwork for rapidly produced complex castings. Graduate students, Dennis Michaud, Josh Lobel and Dimitris Papanikolaou have been utilizing this same methodology for their research in the summer of 2007 with Larry Sass and the Digital Design and Fabrication Group at MIT. (Fig. 7.1.C)



Figure 7.1.C

[limitations to the design]

Although this method was designed to accommodate mass customized and reconfigurable shapes it does have limitations to what it can produce. Layered productions can have resolution issues when dealing with curvature over the longitudinal section. This could be potentially overcome by reducing the thickness of the formwork material however tightening the curvature will affect any resolution at some point. Also, this concept was designed for objects at the human scale that could be cut out of 4'x8' sheets of plywood. Although it hasn't been tested, it is assumed that large castings like concrete culverts would not be effective with this method.

## 7.2 Design & Fabrication Process Methodology + Knowledge

[managing information]

Designers with an interest in making tend to admire the idealistic notations of the master builder and often dream about returning to a like process. We think back to Brunelleschi and marvel at one person who held the knowledge set of five professions. However, quickly the reality of the building industry sets in. When we compare our current methodology to that of Brunelleschi's Dome we console ourselves by telling each other that buildings are too complex, time is too limited and knowledge required for one man is too overwhelming. So instead of focusing on how one person can acquire all of the traits of a master builder, we should be asking ourselves how can we organize the efforts of everyone involved to become a unified master builder? To start, we need to change our process of managing information from a linear design coupled with sequential construction to collective intelligence design and non-gravity assembly.

[linear design vs. collective intelligence design]

Design tends to evolve through a linear process starting with the macro and finishing at the micro scale. Architects are hired by owners to orchestrate the needs, goals, and desires with constraints such as cost and building codes. Decision making occurs in order through a hierarchical tree in a top down process. Issues that contain the most dependent relationships are placed in the beginning and include site analysis, context, programming, and spatial organization. Isolated variables are placed at the end of the decision making process and include paint colors, door hardware, floor coverings, etc. This is directly related to the 3 major design divisions; schematic design, design development and construction documents + specifications.

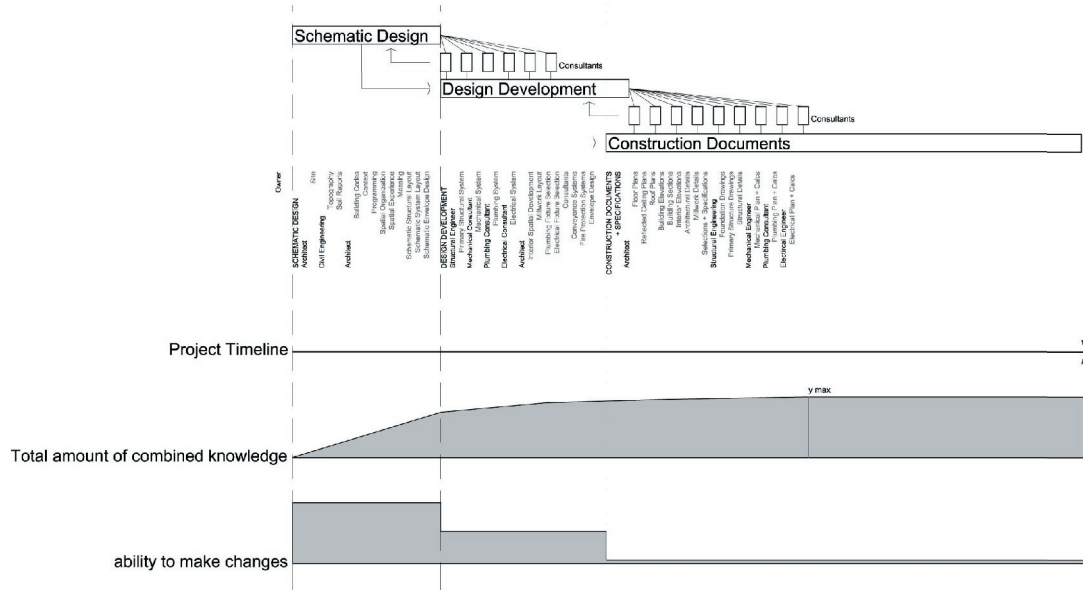

Figure 7.2.A

This process (Fig. 7.2.A) represents an ideal scenario that is never achieved. It assumes that all decisions are binary and changes are never made. All steps are fragmented and broken up into isolated

parts. In this process entities are only concerned with the information provided to them and their task, there is little relationship to other entities. This process hinders dynamic interaction. The information provided them is usually abridged and communication is summarized. In this manner it is impossible to convey all information to every entity, which in turn causes self-interests and overall clarity is muddled. The creation of construction documents is time consuming and prone to inconsistencies. However, it is generally initiated before all decisions have been made and all changes finalized. Therefore when new information is added it becomes difficult to check it in relationship to every part of the project and mistakes become more likely.

In response, this project is proposing an alternative methodology called collective intelligence design (Fig. 7.2.B), which builds from the basis of BIM software. Here design information is organized into 1 digital solid project model and integrated database. The design process uses the same hierarchy as a linear method; the difference is in the way other entities interact with that information and how it is eventually packaged. For example, an architect starts the digital model by creating a three-dimensional simulation of the schematic design. Site information, massing, context, program, spatial organization, spatial experience, proposed structural, mechanical, plumbing and electrical

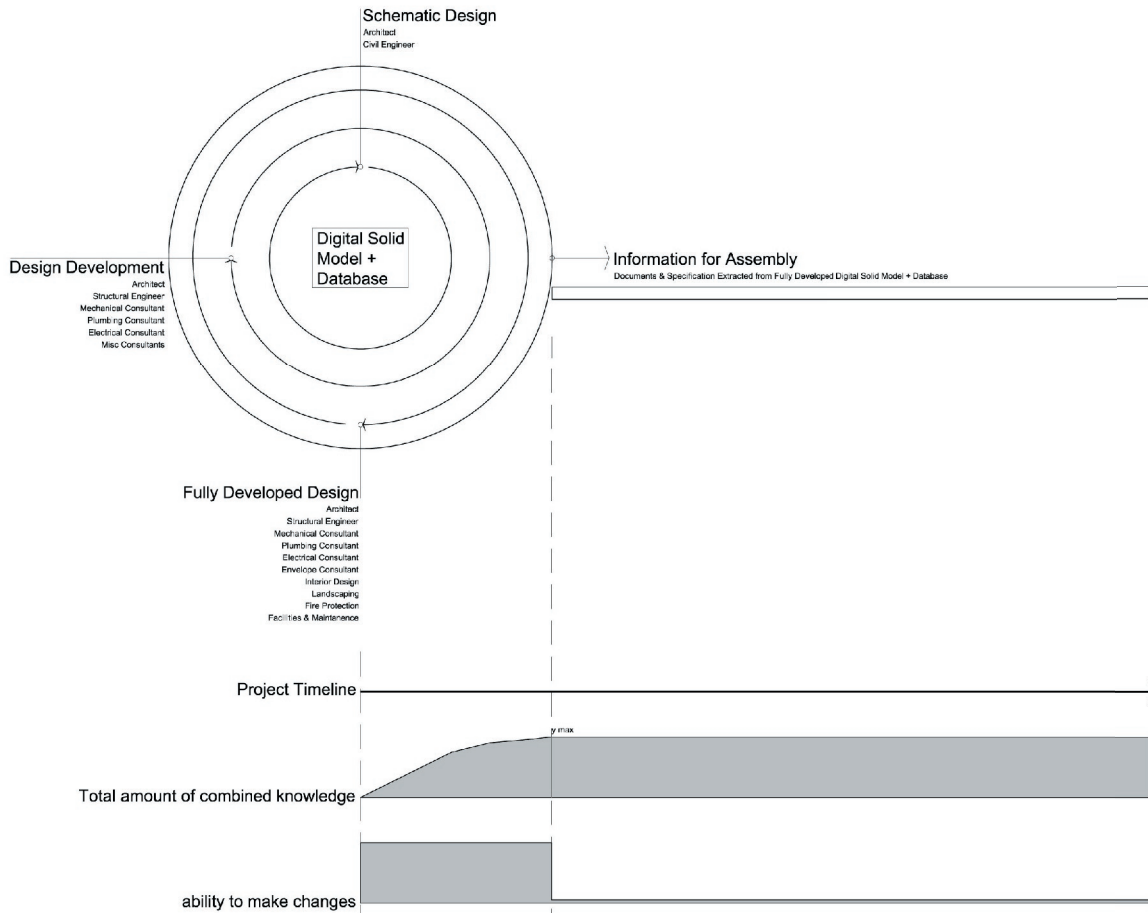

Figure 7.2.B

are inserted into the model. From there, design development consultants can view not only the three-dimensional model but quickly ascertain its embedded information of priorities and project goals. The consultant then designs their system and integrates it directly into the digital model. It becomes immediately visible if the consultant proposes anything that conflicts with another system. When this has been repeated throughout the design hierarchy tree all the way down to the micro scale the digital model will contain all of the design information need to construct the building. Construction information and specifications can be extracted directly from the model and thus reducing the potential for mistakes, inconsistencies or omissions.

When compared to linear design the advantage of collective intelligence is clear. First, the total amount of knowledge (acquired once all consultants have reviewed and contributed to the project) is obtained before work on the construction information documents commences. Therefore, if a consultant towards the end of the hierarchical tree brings a suggestion to improve something further

up the dependency list is can be implemented easily and checked against all other systems instantaneously. In a linear method, a better solution may have to be forgone due to economic or time conditions within the process. Second, the ability to make a change within the linear process decreases with time. Alternatively, in the collective intelligence model changes can be made up until right before the information is extracted for construction documents without the risk of conflicting information. Because the digital model is accurate and inclusive its parts can be extracted into categories and subcategories of like components. The process of fabricating each part can be designed, packaged and sent directly to the fabricator responsible for making it. This method of information management then leads to non-gravity assemblies.

[non gravity assemblies and sequential construction]

Sequential construction is the primary method used for building. Trades are brought to the site in order of their work from the ground up; excavation, utilities, foundations, primary structure, envelope, etc. In most cases, constructors first measure the built work of the trade before them. For example, in the diagram below (Fig. 7.2.C) the steel erector would measure and verify the layout of the footings before commencing fabrication on the steel. This occurs because the construction documents did not provide the steel contractor the dimensions needed to begin fabrication. The architect did not provide the dimension specifically needed in the drawings because the convention used depicts the final product, not the means and methods required for construction. When every trade must first measure the previous work, fabricate and then assemble overall construction time is increased.

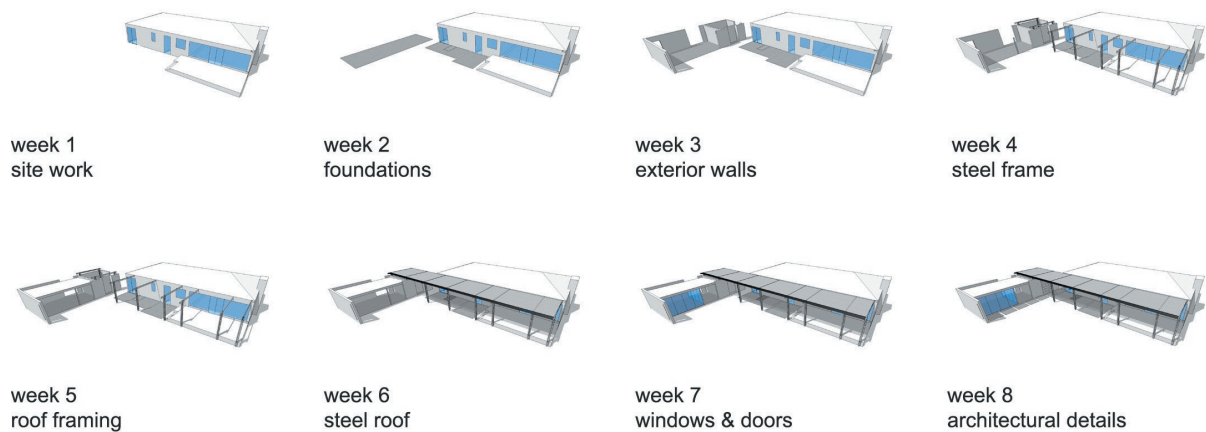

Figure 7.2.C

When construction information is conveyed through a part based system several trades can be working on their portion of the project at the same time, non-gravity assemblies. (Fig. 7.2.D) The term changes from field construction to field assembly as fabricated parts are brought to the site and erected. This greatly reduces the amount of time required for construction and reduces construction cost.

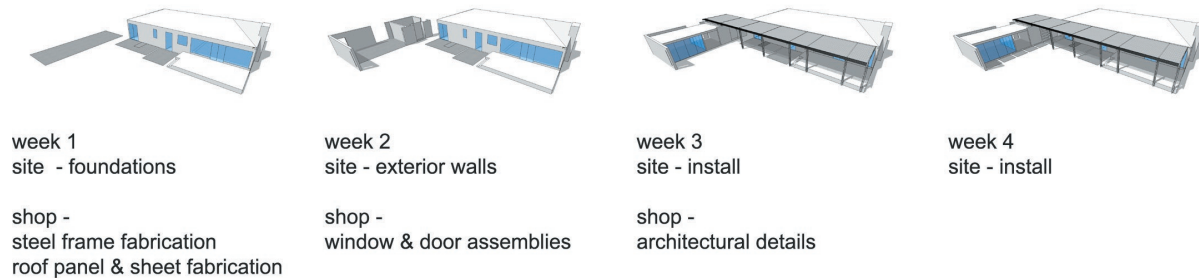

Figure 7.2.D

[Representation vs. Simulation]

Non gravity assemblies through part based designs reiterate the importance of simulation drawings in lieu of representational drawings. Simulation is comprised of digital solid models that mandate all parts within an assembly to be drawn and connected within the model. This mandate embeds another level of information that is often overlooked or unresolved forcing a higher quality. Conventional plans, sections, and renders that are commonly utilized during the development of a schematic design contain little embedded information. According to Stephen Kieran, “Representation is the art of defining one thing or person by use of another. The representation is a proxy, a stand-in for the original. Representation in production provides the information needed to build, but it is incomplete, segregated, and prone to inconsistency.” (Kieran 2004) With simulation, common problems such as clearances, connections, tolerances and space for construction maneuvering would be quickly identified and resolved. Feedback regarding constructability, material selection, time, and cost are also easily embedded and can be analyzed simultaneously through simulation.

It’s important to point out that simulation is the superior method for producing designs for production; however representational drawings can often still be the most effective during the design process. Representational drawings allow designers to convey a feeling or characteristic to explain a design idea to a client. Simulation drawings allow designers to accurately and precisely convey information to a fabricator.

[importance of physical modeling]

Although this investigation encourages the development of designs through solid modeling the importance of physical modeling cannot be emphasized enough. One advantage to digital three dimensional modeling is the ability to rapidly produce a model in an additive process machine, such as a ZCorp Zprinter. Producing physical models provides an array of unforeseen feedback information. Conceptualizing or theorizing about something is all that is, theory. Making provides specific information that helps designers and fabricators to advance their project. Physical modeling also allows for *off-loading* of ideas into a tangible form to reduce cognitive load.

[offloading and physical interfacing]

Another advantage to both digital three dimensional modeling and physical modeling is the ability for designers to *offload* information. As stated before, designers tend to process a vast amount of ideas and information in their minds and use a variety of influences to determine conclusions. This method of information management requires heavy cognitive interactions. By creating and working with simulated and physical models, that contain all of the available constraints and design information, team members are able to *offload* their thoughts into a contained interface and more freely propel design ideas. Kim and Maher discuss this phenomenon in their paper titled, "The Impact of Tangible User Interfaces on Designers' Spatial Cognition". It states, "Rather than 'internalizing' the moves of the 3D objects, the designers performed more 3D modeling actions as epistemic actions, which may reflect a reduction of designers' cognitive load". (Kim and Maher X)

[knowledge management]

Managing vast amounts of information, physical modeling and digital simulation all while working collectively can also have its limits. Knowledge tends to be either explicit or tacit and understanding the type of knowledge produced or extracted from a project effects the overall performance. Explicit knowledge is commonly used communication through language and symbols. "Explicit or codified knowledge may be understood by people with complementary knowledge who can extract meaning from 'codes'." (Anumba 2005) On the other hand, tacit knowledge is embedded knowledge that one receives by 'doing' instead of receiving. Riding a bike is an example of tacit knowledge. Somebody can explain how to do it but you don't



learn it until you “get the feel of it”.

Although most design project information is explicit, some may be tacit and proper methods of handling that information may need to be secured.

### 7.3 Making

This investigation yielded an array of valuable information to the process of making what we design.

[design the means & methods – the part will follow]

When a part has been considered only as a final product and isolated from its process of production the designer releases control of the method used to fabricate the part. However, the process of making reveals substantially more information than just the final object. Designers are intimately familiar with the parts they develop. They are aware of the evolution of the part, its association with its assembly, its prominence within the overall design and its desired performance. This information is difficult to embed in typical methods of communication. For example; tolerance, where is it critical, where can it be relaxed? Relationship to the assembly, how does this part join surrounding parts or completely separate parts? The implications of machine, artifacts left by its manipulation, burrs, scratches, clamp and hold down marks. What tools could potentially leave undesirable effects? Is it important if the piece is cut with a torch or on a metal shear? We rely on somebody to not only understand the visible form of the part, but its obscure associations.

Two likely scenarios usually occur. First, the fabricator is very skilled and will execute every tolerance perfectly and fabricate the part in such a way to show no signs of its making. However, this process can be costly. Second, the fabricator will not be concerned with its relationship to the assembly and implications of machine in which pieces will sometimes not fit or scares will be highly visible.

By designing the means & methods of a parts fabrication the underlying information is embedded into the design of the part. Fabricators will understand hierarchy of tolerances and where components can be held during production to be hidden at final assembly and which tools are most appropriate to utilize.

[intelligent joints]

As stated before, the amount of graphical and textual information required to construct buildings is at an all time high. Concurrently, pricing is becoming tighter which in turn causes less time devoted to managing information by the constructor.

In lieu of adding more sheets of drawings, more notes and more specifications to control the proper installation of components we need to look for new ways of enabling communication. The ability to know instantaneously whether something has been installed incorrectly can be achieved by designing the piece to only 'fit' one way. Self aligning and dictating connections are intelligent joints. They provide the installer immediate feedback on the accurateness of the task performed without having to refer back through many sheets of drawings.

[module assembly]

Although the intelligent joint provides immediate feedback on the proper placement and orientation of the part it does not control the craft or the quality of joining one part to the next. The joining of 2 objects together with precision and craft can be one of the most difficult stages of construction especially when it is compounded with difficult field conditions of weather, altitude, few tools and poorly constructed sub assemblies. The greatest advance in the design of the formworks was the ability to create modules from pieces. By combining 60 pieces to make 3 modules it also limited the amount of joints that would need to be regularly fitted from 60 to 3. (Fig. 7.3.A)

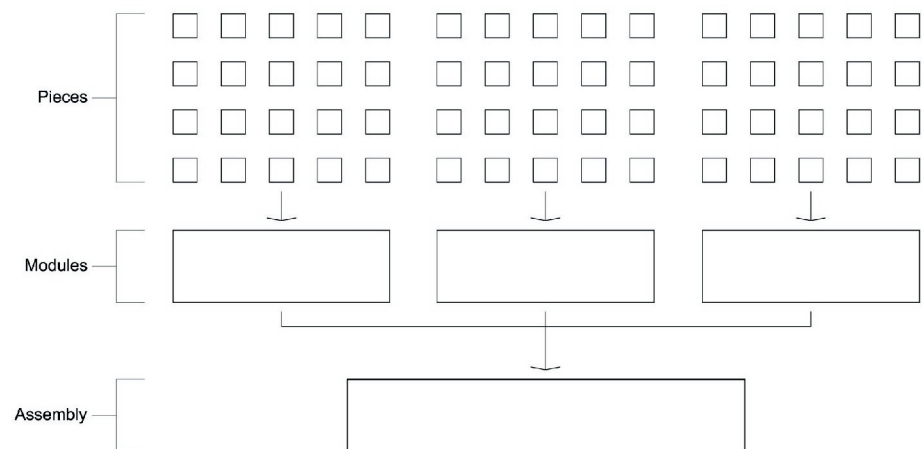

Figure 7.3.A

If architects can design building components as modules that can be assembled in shops under ideal conditions they can limit the amount of precision joining that occurs in the field and thus increasing the quality of the building.

[automating processes]

Automation in construction is an underused technique that provides remarkable efficiency and accuracy in repetitive tasks. By contouring digital solid models through a single command, complex tools paths were extracted with ease and eliminated potential user error. Cutting the formwork layers without the use of an automated laser cutter or CNC machine would have been nearly impossible. The tolerance of the cuts remained within hundredths of an inch and allowed the fabricator to be working on something else while the parts were being made. However, not all tasks can be or should be automated. Single run objects or one time use commands are not efficient in automation due to the extra steps involved in preparing a task to be automated.

[the tool & the hand]

We use tools to assist in the making of things we design. The use of a specific tool should never constrain the development of a design and conversely a design can never be fully realized without considering the tool of its production. Understanding the appropriateness and limitations of a maker's tools enhances their design ability. The relationship between a maker and his tool is cultivated until the tool becomes an extension of the hand.

[listening to materials]

Louis Kahn's famous quote of "brick, what do you want to be – I want to be an arch" echoes any discussion rooted between design & making. It is absolutely critical to really look at the materials being worked with. Look beyond their shape, size & color but at their inherent properties. During the design of the formworks the expansion of the concrete during hydration was indiscernible to the human eye however the consistent 'locking' of the interior layers was undeniable. After many trials and errors the outward concrete expansion was finally realized. The interior of the form was redesigned to accommodate this and the next experiment was an overdue success.

## 7.4 Implementation

[building value for clients]

Architects build value for their clients by providing a service of offering expert knowledge to assist them in the process of identifying needs & desires, organizing space for function & human perception, developing the assembly of materials & systems, working with the government agencies and working with constructors to realize the final product.

In exchange, clients pay architects for their services rendered (time spent) in hourly quantities or negotiated pricing.

[competitive advantage]

Architects compete among themselves by creating a competitive advantage in one of two ways. They either provide the lowest cost service or they provided a differentiated service that conveys a higher perceived value in which clients are willing to pay a premium for. If architects are not doing one of these two models, they are simply floundering in the middle. Defining a differentiated service in a customer service based business is tricky. Generally, products in a product based business are easily ranked from highest to lowest and agreed upon by a majority. Ranking lawyers, consultants or doctors is different in that they don't produce quantifiable data and therefore are often grouped by categories of typology and service.

Regardless, clients will not pay for a new technology, process or methodology unless it provides the architect one of the above mentioned competitive advantages. For example, utilizing the new methodology that is able to create higher quality buildings creates a differentiated service for the architect and can therefore impose higher fees in return for higher quality. In contrast, an architect may also choose to use a new methodology that automates a repetitive task, reduces internal costs, increases margins and enables the architect to be the lowest cost service provider.

[a new way of designing a making]

The compensation architects receive for the value they create is almost always stunted. Although the economics are complex, some of this is rooted to the fact that the products architects produce have little tangible value. For instance, when the architect's service is complete

the client is given a copy of the final construction documents. All of the time, effort, money spent, and decisions made are reflected by the drawings and specifications. However, the documents have little monetary value themselves. It is unlikely that a client could sell the drawings for the amount of money expended for them. For the client to receive the full value of the acquisition of benefits they must construct the design represented in the documents. Another entity creates tangible value by building the project and usually receives a larger compensation per expenditure than the design professionals.

The active role in the design of the means and methods of fabrication proposed in this thesis is one potential method to combat the current situation. Architects would be responsible for information (G Code, templates, part drawings, etc) that is required by fabricators to make the parts. Their product shifts from an overvalued piece of paper to an essential step in the process of production. Its also likely that architects could expand their role into that of limited fabrication. Having already conceived, designed and considered the process of making the part they could eliminate the translation to a separate entity and construct certain elements within house.

Revised Value Chain - Design to Production

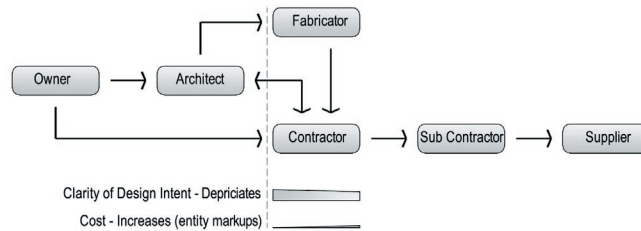

Figure 7.4.A

The above value chain diagram (Fig 7.4.A) contrasts the traditional paradigm (Fig. 2.1.F) by moving the fabricator, the entity responsible for actually making the part next to the designer. With the designer as fabricator there is no loss in design intention and the potential for profit is higher by eliminating the traditional markup and supervision cost associated by the sub contractor and supplier.

## 8.0 Figures

All images and drawings are by the author unless noted otherwise.

- Figure 1.1A General sequence of communication from developed concept to construction.
- Figure 1.2B Vignettes from various sections of the thesis.
- 
- Figure 2.1A Santa Maria del Fiore Cathedral – Florence, Italy, from Britannica Online.
- Figure 2.1B Brunellesci’s Helical screw jack as drawn by Taccola
- Figure 2.1C Shinden House of Daikakuji Temple – Kansai, Japan. Kansai International Public Relations Promotion Office.
- Figure 2.1D Typical 2D plan drawings. By the author, courtesy of Repp Design & Construction.
- Figure 2.1E Sever Hall by H.H. Richardson at Harvard University. Harvard University Libraries.
- Figure 2.1F Traditional Value Chain Diagram.
- Figure 2.1G Zahner Corporation installing exterior wall panels, Gehry Partners Stata Center, MIT. MIT Facilities.
- Figure 2.1H Tri Pyramid Componets, Brooklyn Museum Entry Pavilion & Plaza, & Tri Pyramid / Polshek Partnership.
- Figure 2.2A Ford assembly line 1929. Henry Ford Museum.
- Figure 2.2B Automotive front end module. ThyssenKrupp.
- Figure 2.2C Skilled human craft. Fine Woodworking Online.
- Figure 2.2D Exploited human craft. [www.kbhomesucks.com](http://www.kbhomesucks.com).
- Figure 2.2E Solid Modeling – Digital Project.
- Figure 2.2F Parametric Modeling – Generative Components.
- Figure 2.2G BIM Modeling. Architectural Record Online.
- Figure 2.2H ZPrinter 310. Z Corporation.
- Figure 2.2I X2 660 Laser Cutter. Universal Laser.
- Figure 2.2J LC Series 4556 Numerically controlled router Techno CNC.
- 
- Figure 3.4A Map of the southwestern United States.
- Figure 3.4B Map of southern Arizona.
- Figure 3.4C Map of rural areas within southern Arizona.
- Figure 3.4D Plan of proposed site.
- Figure 3.4E Photograph of proposed site.
- Figure 3.4F Cross section of proposed design.
- Figure 3.4G Cross sections of mass customizable floor plates.

Figure 3.4H	Plan drawing of proposed design.	
Figure 3.4I	Transverse section of proposed design.	
Figure 3.4J	Exploded structure drawing of proposed design.	
Figure 3.4K	Concrete unit variations.	
Figure 3.4L	Concrete unit proposed shape.	
Figure 3.4M	Proposed mass customizable concrete unit to standard CMU block comparison.	
Figure 3.4N	Rendering of proposed design solution 1.	
Figure 3.4O	Rendering of proposed design solution 2.	
Figure 3.5A	Traditional drawings of design information.	
Figure 3.5B	Proposed new method drawings of design information.	
Figure 5.1A	Design to fabrication diagram.	
Figure 5.2B	Rendering of the mass customizable wall unit.	
Figure 5.2C	Fabrication of a conceptualized part diagram.	
Figure 5.2D	Casting with steel molds.	
Figure 5.2E	Casting with polyurethane elastomer rubber.	
Figure 5.2F	Material comparison charts.	
Figure 5.2G	Box model form material testing.	
Figure 5.2H	Casting with negative layer fabrication.	
Figure 5.2I	Fabrication procedure process.	
Figure 6.2A	Digital solid model created in Rhino.	
Figure 6.2B	Physical models, ZCorp Printer.	
Figure 6.2C	Layered masonite form sheets.	
Figure 6.2D	Casting a model.	
Figure 6.3A	Formwork 1 design	solid model, horizontal contouring, layout cut sheet
Figure 6.3B	Formwork 1 design	full cut sheet
Figure 6.3C	Formwork 1 model	masonite layered model
Figure 6.3D	Formwork 1 procedure	rockite model
Figure 6.4A	Formwork 2 design	layout cut sheet
Figure 6.4B	Formwork 2 model	registration marks, labels & draft angles
Figure 6.4C	Formwork 2 procedure	pieces, tools, formwork & cast
Figure 6.5A	Formwork 3 design	layout cut sheet
Figure 6.5B	Formwork 3 model	formwork cast
Figure 6.5C	Formwork 3 procedure	multiple casting
Figure 6.6A	Formwork 4 model	acrylic formwork
Figure 6.6B	Formwork 4 procedure	broken casts
Figure 6.7A	Formwork 5	fabrication process diagram
Figure 6.7B	Formwork 5 design	triangle shaped units

Figure 6.7C	Formwork 5 design	solid modeling and contours
Figure 6.7D	Formwork 5 design	triangle layout cut sheet
Figure 6.7E	Formwork 5 model	triangle masonite formwork
Figure 6.7F	Formwork 5 procedure	overwhelming amount of pieces
Figure 6.8A	Formwork 6 design	parts, modules, assemblies
Figure 6.8B	Formwork 6 design	triangle layout cut sheet
Figure 6.8C	Formwork 6 model	triangle masonite formwork
Figure 6.8D	Formwork 6 model	triangle masonite formwork
Figure 6.8E	Formwork 6 procedure	triangle modules
Figure 6.8F	Formwork 6 procedure	triangle casts
Figure 6.9A	Formwork 7 design	corner wall condition
Figure 6.9B	Formwork 7 design	solid modeling
Figure 6.9C	Formwork 7 model	8 formworks
Figure 6.9D	Formwork 7 procedure	corner wall casts
Figure 6.10A	Formwork 8 design	full scale triangle layout
Figure 6.10B	Formwork 8 model	full scale CNC machining
Figure 6.10C	Formwork 8 model	pieces, sets, modules
Figure 6.10D	Formwork 8 model	full scale formwork
Figure 6.10E	Formwork 8 procedure	full scale casting
Figure 6.10F	Formwork 8 procedure	full scale cast
Figure 6.10G	Formwork 8 procedure	problematic areas
Figure 6.11A	Formwork 9 design	connection tolerance
Figure 6.11B	Formwork 9 design	interior module design
Figure 6.11C	Formwork 9 model	triangle masonite formwork
Figure 6.11D	Formwork 9 model	triangle masonite formwork
Figure 6.11E	Formwork 9 procedure	cast
Figure 6.11F	Formwork 9 procedure	horizontal tolerance connection
Figure 6.11G	Formwork 9 procedure	vertical tolerance connection
Figure 6.12A	Formwork 10 model	full scale with interior modules
Figure 6.12B	Formwork 10 procedure	casting
Figure 6.12C	Formwork 10 procedure	casting
Figure 6.12D	Formwork 10 procedure	cast
Figure 6.13A	Formwork 11 design	full scale cut sheets
Figure 6.13B	Formwork 11 model	full scale formworks
Figure 6.13C	Formwork 11 model	formwork 1
Figure 6.13D	Formwork 11 model	formwork 2
Figure 6.13E	Formwork 11 procedure	pouring
Figure 6.13F	Formwork 11 procedure	removing interior modules
Figure 6.13G	Formwork 11 procedure	releasing exterior modules
Figure 6.13H	Formwork 11 procedure	removing exterior modules



Figure 6.13I Formwork 11 procedure casts 1 & 2  
Figure 6.13J Formwork 11 procedure cast 3  
Figure 6.13K Formwork 11 procedure cast4 - final assembly  
Figure 6.14A Packaging Design Information  
Figure 6.14B Sequence of Design

Figure 7.1A 11 Formwork and casts.  
Figure 7.1B Model and procedure times.  
Figure 7.1C DDFG group work.  
Figure 7.2A Linear design process.  
Figure 7.2B Collective intelligence design process.  
Figure 7.2C Sequential construction diagram.  
Figure 7.2D Non gravity assembly diagram.  
Figure 7.3A Pieces, Modules & Parts diagram.  
Figure 7.4A Revised Value Chain Diagram

## 9.0 Bibliography

Anumba, Chimay et al. *Knowledge Management in Construction*. Oxford, Blackwell Publishing, 2005

Bechthold, Martin et al. "New technologies in architecture, Digital design and manufacturing techniques. Cambridge, Harvard University Graduate School of Design (2000)

Bechthold, Martin. "Surface Structures: digital design and fabrication" ACADIA: Structures 88-98

Botha, Marcel. "Customized Digital Manufacturing: Concept to Construction methods across varying product scales." MIT, Cambridge, USA (2006)

Buntrock, Dana. *Japanese architecture as a collaborative process: opportunities in a flexible construction culture*. New York, Spohn Press, 2002

Chaturvedi, Swati and Ochsendorf, John. "Global Environmental Impacts due to Cement and Steel." Structural Engineering International (2004) 1 – 5

Eastman, Charles et al. "Parametric 3D modeling in building construction with examples from precast concrete." Automation in Construction 13 (2004) 291 – 312

Emmitt, Stephen and Gorse, Christopher. *Construction Communication*. Oxford, Blackwell Publishing, 2003

Gonchar, Joann. "Transformative tools start to take hold. A critical mass of building information modeling projects demonstrates the technology's benefits and its potential for redefining practice." Architectural Record April, 2007: 155-162

Gould, Frederick and Joyce, Nancy. *Construction project management*, Upper Saddle River, Prentice Hall, 2000

Griggs, Kimo et al. "New technologies in architecture II & III, Digital design and manufacturing techniques. Cambridge, Harvard University Graduate School of Design (2003)

Jennings, Richard. Personal Interview April 23, 2007  
Doctor of Design Candidate, Harvard University GSD

Kieran, Stephen and Timberlake, James. *Refabricating Architecture, How manufacturing methodologies are poised to transform building construction*, New York, McGraw-Hill Company, 2004

Kim, Mi Jeong and Maher, Mary Lou. "The Impact of Tangible User Interfaces on Designers' Spatial Cognition." (2006) 1-33.

Kind - Barkauskas et al. *Concrete Construction Manual*. Basel, Birkhauser, 2002

King, Ross. *Brunelleschi's Dome, how a renaissance genius reinvented architecture*. New York, Penguin Books, 2000

Matsushima, Shiro. "Technology-Mediated Process: MIT Stata Center case study." *ACADIA: Architectural Practice* 202 – 218

Morris, A. *Precast Concrete in Architecture*. New York. Watson - Guptill Publications 1978

Muligan, Donald and Knutson, Kraig. *Construction and Culture, A built environment*, Champaign, Stipes Publishing, 1999

Porter, Michael. *Competitive Advantage*, New York, The Free Press, 1985

Pressman, Andrew. "Integrated practice in perspective: A new model for the architectural profession." *Architectural Record* June, 2007: 116-120

Rice, Peter. *An Engineer Imagines*, London, Ellipsis London Limited, 1994

Seely, Jennifer. "Digital Fabrication in the Architectural Design Process." MIT, Cambridge, USA

Woods, Mary. *From craft to profession: the practice of architecture in nineteenth-century America*. Berkeley, University of California Press, 1999