

**Electrocardiography in DICOM**

OCT 29 1997

by

**Chanathip Namprempe**

S.B., Computer Science and Engineering (1996)

Massachusetts Institute of Technology

Submitted to the Department of Electrical Engineering and Computer Science  
in Partial Fulfillment of the Requirements for the Degree of  
Master of Engineering in Electrical Engineering and Computer Science

at the Massachusetts Institute of Technology

May 23, 1997

Copyright 1997 Massachusetts Institute of Technology. All rights reserved.

Author .....  
Department of Electrical Engineering and Computer Science  
May 23, 1997

Certified by .....  
C Forbes Dewey, Jr.  
Thesis Supervisor

Accepted by .....  
Arthur C. Smith  
Chairman, Department Committee on Graduate Theses

# **Electrocardiography in DICOM**

by

**Chanathip Namprempe**

Submitted to the  
Department of Electrical Engineering and Computer Science

May 23, 1997

In Partial Fulfillment of the Requirements for the Degree of  
Master of Engineering in Electrical Engineering and Computer Science

## **Abstract**

This thesis proposes supplements to the Digital Imaging and Communications in Medicine (DICOM) standard to support electrocardiogram (ECG) data. These supplements include new Information Object Definitions (IOD) and related Modules designed to handle not only the signal traces but other ECG specific measurements and information as well. The new IODs are ECG Signal IOD and ECG Interpretation IOD. The new Modules are ECG Series Module, ECG Equipment Module, ECG Preview Module, and ECG Interpretation Module. Like the DICOM standard itself, these object definitions and modules are designed using an object-oriented modeling approach. Consequently, adding them to the standard only requires minimal changes to its existing parts. To prove the functionality of the new IODs and Modules, a DICOM Electrocardiogram Viewer program has been implemented. It is written in Java and, thus, is platform independent. It has been tested on an Intel Pentium computer running Windows 95 operating system. Its client-server architecture allows multiple ECG readers to share a pool of resources consisting of ECG recordings. The client portion of the program can function both as an application and as a Java applet, thus allowing the program itself to be executed from anywhere on the Internet.

Thesis Supervisor: C Forbes Dewey, Jr.  
Title: Professor of Mechanical Engineering

## Acknowledgments

The work presented in this thesis was supported by the International Consortium for Medical Imaging Technology (ICMIT).

I am indebted to my advisor, Professor C Forbes Dewey, Jr., for his invaluable inputs and advice throughout the project. I would like to thank him especially for his confidence in my ability and his patience.

I would like to thank Patrick McCormick for sharing his insights and knowledge about the DICOM standard and many other areas. I thank Alexander Zakharov for being a good friend when I need one. I thank Ron Weiss, Bienvenido Velez-Rivera, and Mark Sheldon for being my teachers and good friends. Their knowledge, strength and determination never cease to impress me.

Special thanks go to P'Yoy and P'Roong for being there for me throughout the years. They have made my life at MIT enjoyable. I could never have made it through MIT with my sanity intact if it were not for their support and encouragement.

I also would like to thank my mother and sister for their love and support. I am forever grateful for what my mother has endured for me to have a chance to excel. My sister's incomparable perseverance has also given me an inspiration to strive for the best. I am blessed to have such a family.

Last, but not least, I thank my best friend, Michael Duff, for his unconditional love and support. I thank him for his inspirational personality. I thank him for his strength and sense of humor. He has truly made this country feel more like home.

*I'll always love you, Meau.  
- Michael*

# Contents

<b>1</b>	<b>Introduction</b>	<b>8</b>
<b>2</b>	<b>The Digital Imaging and Communications in Medicine Standard Version 3.0</b>	<b>10</b>
2.1	DICOM Real-World Model . . . . .	11
2.2	The DICOM Standard . . . . .	13
2.2.1	Information Object Definitions . . . . .	14
2.2.2	Service Class Specifications . . . . .	14
2.2.3	Data Dictionary . . . . .	15
<b>3</b>	<b>New Information Object Definitions and Modules</b>	<b>16</b>
3.1	ECG Series . . . . .	19
3.2	ECG Equipment . . . . .	19
3.3	ECG Preview . . . . .	19
3.4	ECG Interpretation . . . . .	20
<b>4</b>	<b>Prototype Implementation</b>	<b>22</b>
4.1	DICOM-Formatted Electrocardiogram Data Generation . . . . .	22
4.2	DICOM Electrocardiogram Viewer . . . . .	23
4.2.1	Graphical User Interface . . . . .	23
4.2.2	Implementation . . . . .	27
4.3	How to Acquire the ECG Viewer . . . . .	31
<b>5</b>	<b>Conclusions</b>	<b>32</b>
<b>A</b>	<b>Part 3 Addendum Electrocardiogram Information Object Definitions</b>	<b>33</b>
A.1	Addendum to Annex A of Part 3 of the DICOM Standard . . . . .	33

A.1.1	Proposed ECG Signal Information Object Definition . . . . .	34
A.1.2	Proposed ECG Interpretation Information Object Definition . . . . .	35
A.2	Addendum to Annex C of Part 3 of the DICOM Standard . . . . .	36
A.2.1	Proposed ECG Series Module . . . . .	36
A.2.2	Proposed ECG Equipment Module . . . . .	44
A.2.3	Proposed ECG Preview Module . . . . .	45
A.2.4	Proposed ECG Interpretation Module . . . . .	46
A.2.5	Proposed Addendum to Item C.7.3.1.1.1 of Annex C of Part 3 of the DICOM Standard . . . . .	63
<b>B</b>	<b>Part 4 Addendum Electrocardiogram Storage SOP Classes</b>	<b>64</b>
B.1	Addendum to Annex B of Part 4 of the DICOM Standard . . . . .	64
B.1.1	Standard SOP Classes . . . . .	64
<b>C</b>	<b>Part 6 Addendum Electrocardiogram Data Dictionary</b>	<b>65</b>

# List of Figures

2-1	DICOM Model of the Real World . . . . .	12
3-1	An Example of a Typical Electrocardiogram Report . . . . .	17
3-2	ECG Series Module Organization . . . . .	20
4-1	Steps involved in converting MIT-BIH database to DICOM . . . . .	23
4-2	Graphical User Interface of the Program . . . . .	24
4-3	Load Dialog Box . . . . .	25
4-4	Sub-menus of View Menu Item . . . . .	25
4-5	Sub-menus of View Menu Item . . . . .	26
4-6	A Sample Scenario of an Interaction between a Client and the Server . . . . .	28
4-7	Client and Server Communication Protocol . . . . .	28
4-8	Relationships among ClientApp, GUI, Command and ECGViewport . . . . .	30
A-1	Possible P and T Morphology Types . . . . .	41

# List of Tables

3.1	Composite Information Object Modules Overview . . . . .	18
4.1	Client’s Requests and Babysitter’s Actions and Responses . . . . .	29
A.1	ECG-S IOD Modules . . . . .	34
A.2	ECG Interpretation Information Object Definition Modules . . . . .	35
A.3	ECG Series Module . . . . .	37
A.4	ECG Equipment Module . . . . .	44
A.5	ECG Preview Module . . . . .	45
A.6	ECG Interpretation Module . . . . .	46
B.1	Electrocardiogram Standard SOP Classes . . . . .	64
C.1	ECG Addendum to the Data Dictionary . . . . .	65
C.2	Addendum to the List of Unique Identifiers . . . . .	68

# Chapter 1

## Introduction

Electrocardiography is a study of electrical activity generated by the heart. As the heart undergoes depolarization and repolarization processes during each beat, the electrocardiogram (ECG) is recorded from the body surface. This graphical recording is proven to be helpful in detecting irregular rhythms, damaged heart muscle and other cardiac abnormalities. As a result, it has become one of the most common tools in diagnosing all forms of heart disease.

Most modern electrocardiographs produce digital recording which can be easily made available for sophisticated data analysis using computers. However, like many other medical diagnostic tools, electrocardiography encounters the problem of a lack of a communication standard. Different electrocardiograph manufacturers have developed their own techniques for handling and transmitting data. Therefore, a recording obtained from an equipment manufactured by the vendor “A” cannot be interpreted by another system produced by the vendor “B” unless they have made an agreement about the representation of the data.

The Digital Imaging and Communications in Medicine (DICOM) standard defines medical image formats that can be used by equipment from many conforming manufacturers. One of the goals of DICOM is to define an interface between the components involved in the communication so that interoperability can be achieved. Currently, various imaging modalities, such as Computed Tomography (CT), Magnetic Resonance (MR) and Nuclear Medicine (NM), are part of the DICOM standard. Adding support for ECG data to the DICOM standard will allow various ECG equipment and viewers manufactured by different vendors to communicate.

Incorporating support for ECG recordings into the DICOM standard is possible because the DICOM standard was designed using an object-oriented approach. In DICOM, each image



object is a compound entity in the sense that it encompasses not only the image itself but also other accompanying information. This information includes, for example, the interpretation of the image and the medical and demographic information about the patient who is the subject of the study that produced the image. Without these pieces of information, the image data would not be useful in a clinical context.

The compound entity is called, in DICOM terminology, “a Composite Information Object Definition” (Composite IOD). Currently, DICOM support, among others, a Standalone Curve IOD which is a composite IOD for graphical data that can be specified as a series of connected points. Although it seems fit for representing electrocardiogram recordings (ECG), a Standalone Curve IOD lacks supports for various ECG-specific data associated with each recording, such as the types of leads, filters and calibration signal used in the test. Therefore, a new ECG-specific Information Object Definition is needed to provide full support for electrocardiogram data within the DICOM standard.

This thesis proposes new Information Object Definitions and related modules to be incorporated into the DICOM standard to support electrocardiogram data. It also proposes a design for an ECG-specific interpretation module to be used as part of a future extension of DICOM to support diagnostic information across all modalities. A prototype has also been implemented to prove the functionality of the new object definitions.

It is worth noting that much of the work in the ECG-specific interpretation module presented in this thesis is based on the European pre-standard [7], which specifies a data format and a low level protocol for serial transmission of ECG data and other measurements. The pre-standard has been voted on by the members of European Committee for Standardization and has been adopted by various electrocardiograph manufacturers.

The organization of this thesis is as follows. Chapter 2 describes the organization of the DICOM standard Version 3.0 and explains parts of the standard that are relevant to this thesis. Chapter 3 introduces the new Information Object Definitions and Modules added to the DICOM Standard to provide a support for electrocardiogram data and related information. Chapter 4 discusses the design and implementation of the prototype. Chapter 5 concludes this thesis and discusses future work. The appendices provide supplements to the DICOM standard to be submitted for approval from the American College of Radiology (ACR) and the National Electrical Manufacturers Association (NEMA).

## Chapter 2

# The Digital Imaging and Communications in Medicine Standard Version 3.0

As image processing technology becomes increasingly sophisticated, the extent to which it can be utilized depends largely on the ability to transfer the data among the data producers, consumers, and repositories. The Digital Imaging and Communications in Medicine (DICOM) standard defines the interface between these components and a network to increase the chance of their interoperability especially for handling medical images. The standard is a result of the collaborative efforts among universities, standards organizations, and commercial organizations around the world. The project was initiated in 1983 by ACR and NEMA who together formed a joint committee to develop the first version of the standard.

After a series of improvements was made, version 2.0 of the standard was published. Version 3.0 was developed during the late 1980s and early 1990s and published in 1993. Since then, there has been significant activity to extend and amend the standard; over 30 supplements and amendments have been proposed.

The DICOM standard utilizes object-oriented design principles to encapsulate various element Modules that together constitute a particular object into an entity called an Information Object Definition (IOD). With this design, the process of improving and extending the standard is greatly simplified. Section 2.1 shows how DICOM IODs correspond to real-world entities. Details of the parts of the DICOM standard relevant to this thesis are discussed in section 2.2.

## 2.1 DICOM Real-World Model

Figure 2-1<sup>[1]</sup> illustrates the DICOM view of the real world. Each rectangular box represents a real-world entity connected by arrows pointing to other real-world entities to which it is related. A relationship between two real-world entities is indicated in a diamond shape box located between them. This information model defines the scope of the DICOM standard.

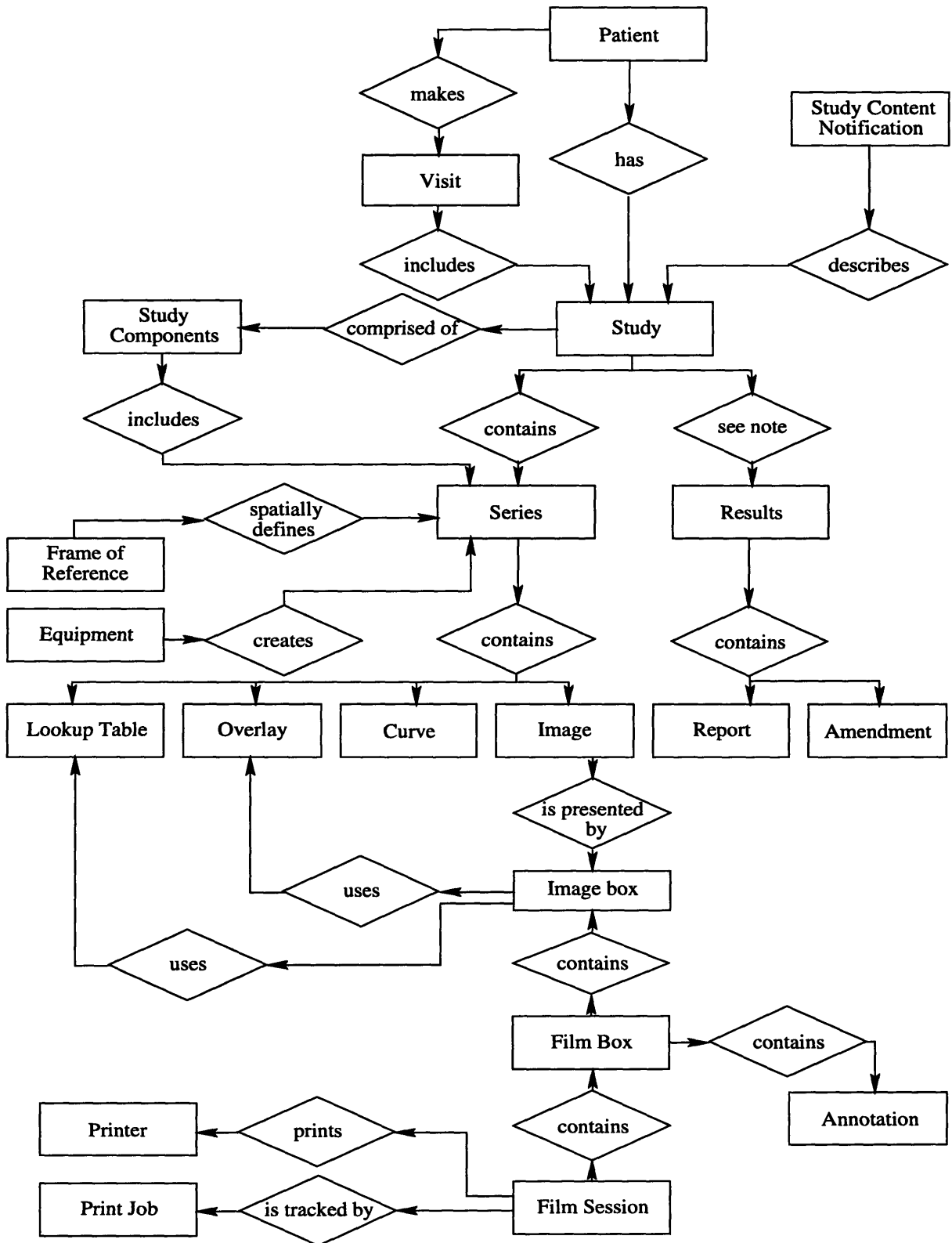

Note: The relationship between Study and Results is complex, involving other real-world objects (e.g. the interpreting physician). This standard does not model these objects.

Figure 2-1: DICOM Model of the Real World

## 2.2 The DICOM Standard

The DICOM standard is composed of 12 related, but independent parts:

**Part 1 Introduction:** This part provides an overview of the DICOM standard.

**Part 2 Conformance:** This part contains a conformance statement provided by a manufacturer claiming an implementation to be “DICOM conformant.” It is used to help the users choose which products to buy when interoperability with other existing DICOM conformant products is an issue.

**Part 3 Information Object Definitions:** This part is the heart of the DICOM standard. It contains the definitions of the object classes supported by the standard.

**Part 4 Service Class Specifications:** This part provides the service class specifications. A service class is a collection of Service-Object Pairs (SOP) each of which is the union of a specific set of services and a related Information Object Definition.

**Part 5 Data Structure and Semantics:** This part specifies the encoding of DICOM Data Elements.

**Part 6 Data Dictionary:** This part contains the listing of all Data Elements along with their names, tags, types and other associated information.

**Part 7 Message Exchange:** This part defines the protocols and services required to accomplish the service classes described in Part 4.

**Part 8 Network Communication Support:** This part defines the network support for exchanging the DICOM messages constructed as defined in Part 7.

**Part 9 Point-to-Point Communication Support:** This part of the standard describes a 50-pin interface which is used by applications that are connected to an old equipment.

**Part 10 Media Storage and File Format:** This part lays a foundation for Part 11 and 12 by specifying a general model for the storage of medical images on removable media.

**Part 11 Media Storage Application Profiles:** This part specifies standard sets of elements from other parts of the DICOM standard related to a specific clinical need.

**Part 12 Storage Functions and Media Formats:** This part defines a number of standard physical media and corresponding media formats suitable for medical image exchange.

The parts that are of main concern in providing support for electrocardiogram data are parts 3, 4, and 6.

### **2.2.1 Information Object Definitions**

Part 3 of the standard contains the definitions of DICOM information objects called, in DICOM terminology, Information Object Definitions (IOD). An IOD is a set of Modules. For instance, a Nuclear Medicine Image IOD is composed of Modules that constitute the information related to a Nuclear Medicine (NM) image such as the Patient Module, the NM Equipment Module, and the NM image. Each of these Modules, in turn, is a group of Attributes. The Patient Module, for example, contains various Attributes such as the patient's name, identification number and birth date. These Attributes are encoded as DICOM Elements according to their Value Representation (VR) codes as described in Part 5 of the standard. A typical DICOM-formatted file is composed of various such Elements.

The DICOM standard categorizes IODs into two types: Composite and Normalized. A Composite IOD contains both the Attributes that are inherent to the real-world entity and the Attributes that are related, but not inherent to it. For example, the Nuclear Medicine image IOD contains both the image date, which is inherent to an NM image, and the patient's name, which is related, but not inherent to it. A Normalized IOD is an object definition that contains only the Attributes inherent to a real-world entity. A patient's name, for example, is inherent to a Normalized IOD called a Patient IOD.

The main portion of Part 3 of the DICOM standard is the three annexes—A, B and C—which define Composite IODs, Normalized IODs and Module Attributes, respectively.

### **2.2.2 Service Class Specifications**

Part 4 of the DICOM standard contains Service Class Specifications. A Service Class is a collection of Service-Object Pairs (SOP) each of which is the union of an Information Object Definition and a specific set of related services. An SOP can be thought of as, in object oriented terminology, a pair of an object class and its associated method.

The main portion of Part 4 of the DICOM standard is the annexes which provides the Ser-

vice Class specifications. There are 7 Service Classes currently defined. They are Verification, Storage, Query/Retrieve, Study Content Notification, Patient Management, Study Management, Results Management, and Print Management Service Classes. The Service Classes that are of concern in adding support for ECG data to DICOM are the Storage and Query/Retrieve Service Classes.

### **2.2.3 Data Dictionary**

Part 6 of the DICOM standard contains the listing of all Data Elements along with their associated information. A Data Element is essentially an encoded Attribute. It is identified by a tag which is a pair of numbers. The first number is a group number. It indicates the group to which a Data Element belongs. For example, group 10 is composed of Data Elements that contain patient's demographic information. The second number is a number assigned to a Data Element uniquely with respect to other Data Elements within the same group.

The other portion of Part 6 contains a central registry of DICOM Unique Identifiers (UID). It contains all the UIDs used through out the Parts of the standard. For example, the CT Image Storage class is assigned a UID of 1.2.840.10008.5.1.4.1.1.2. Having a central registry of UID ensures that there will be no duplicates when additional UIDs are assigned.

## Chapter 3

# New Information Object Definitions and Modules

A main Information Object Definition that needs to be added to Part 3 of the DICOM Standard is one that supports the ECG signal samples and relevant measurements. However, since most modern electrocardiogram recording devices come equipped with the capability to interpret the data, it is important that the interpretation information is supported in this supplement of DICOM as well. The current design separates the interpretation and the signal traces into two distinct IODs since it is possible that the interpretation of a single set of signal traces is conducted in series with one or more equipment that may be different from that used to record the signal traces. As a result, an ECG interpretation will have its own study and equipment information that is different from that of the signal traces. Hence, two new Information Object Definitions needed are ECG Interpretation IOD and ECG Signal IOD. The ECG Interpretation IOD (ECG-I) contains information about interpretation of the ECG signal while the ECG Signal IOD (ECG-S) contains the signal traces and its associated book-keeping information.

ECG-S IOD will be composed of 8 mandatory Modules and 3 optional Modules. They are Patient, General Study, Patient Study, General Series, ECG Series, General Equipment, ECG Equipment, Overlay Plane, Curve Identification, ECG Preview and SOP Common. The rationale for including these Modules can be explained by analogy with a real ECG report obtained from a typical electrocardiograph as shown in Figure 3-1.

An ECG Series can be thought of as comprising the information contained in one ECG report. It includes information such as the total number of leads being measured, the type of



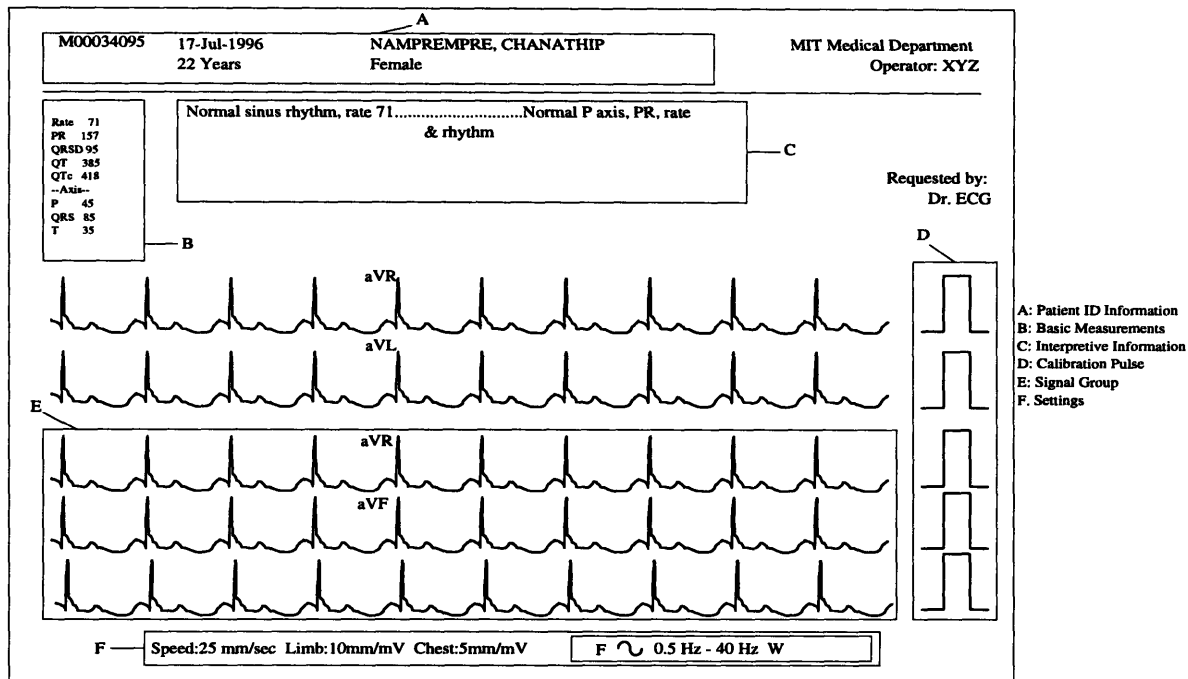

Figure 3-1: An Example of a Typical Electrocardiogram Report

filters used in processing the ECG signals, and the current speed setting of the electrocardiograph used in producing the report. Since, in practice, a certain set of leads are almost always viewed together in one group, an ECG Group Sequence is also included in the ECG Series Module. An ECG Group Sequence contains signals that belong to the same signal group. Usually, there are 3, 6 or 12 signals per group. ECG Series, Equipment, Preview, and Interpretation Modules will be explained in detail in section 3.1, 3.2, 3.3, and 3.4, respectively.

Table 3.1 provides the overview of the Composite Information Object Definitions and the Modules. Data are included to compare the proposed ECG information elements with those of other approved DICOM image modalities such as CT and MR. A character “M” (for Mandatory) indicates that the IOD in the corresponding column must include the Module in the corresponding row. A character “U” (for User-defined (*i.e.* optional)) indicates that the Module may or may not be included in the IOD. A character “C” (for Conditional) indicates that the Module will be required only when a certain condition is met.

Note that the Modules contained in an ECG Signal IOD and an ECG Interpretation IOD do not contain the same information even though they have the same name. For instance, the General Series Module corresponding to an ECG-S IOD will contain the information about

Table 3.1: Composite Information Object Modules Overview

Module	Information Object Definitions						
	CR	CT	MR	...	Study Desc.	ECG Signal	ECG Interpretation
Patient	M	M	M	...		M	M
Patient Summary				...			
General Study	M	M	M	...		M	M
Patient Study	U	U	U	...		U	U
Study Content				...	M		
General Series	M	M	M	...		M	M
ECG Series				...		M	
Frame of Reference		M	M	...			
US Frame of Ref				...			
General Equipment	M	M	M	...		M	M
ECG Equipment				...		M	U
General Image	M	M	M	...			
Image Plane		M	M	...			
Image Pixel	M	M	M	...			
Contrast/Bolus	C	C	C	...			
Cine				...			
Multi-frame				...			
CR Image	M			...			
CT Image		M		...			
MR Image			M	...			
NM Image				...			
NM SPECT				...			
NM Multi-gated				...			
US Region Calibration				...			
Us Image				...			
SC Image				...			
Overlay Identification				...			
Overlay Plane	U	U	U	...		U	U
Multi-frame Overlay				...			
Curve Identification				...		M	
Curve				...			
Audio				...			
Modality LUT	U			...			
VOI LUT	U	U	U	...			
LUT Identification				...			
ECG Preview				...		U	U
ECG Interpretation				...			M
SOP Common	M	M	M	...	M	M	M

the ECG recordings in the Series such as the date the data is recorded and the technician who operates the equipment. However, the General Series Module that belongs to an ECG Interpretation will contain information about the *interpretation* Series. The date is the date on which the interpretation is performed or recorded. Similarly, the technician's name is the name of the person who interprets the data. The actual interpretation will be part of ECG Interpretation Module which will provide a reference to the ECG recording from which the interpretation is derived.

### **3.1 ECG Series**

The ECG Series Module is composed of 74 DICOM Attributes, most of which capture the properties and measurements of the signals in the series. Examples of such properties and measurements include the number of signals in the series, QT interval, and Filter information. Table A.3 in Appendix A.2.1 lists the names of all Attributes in ECG Series Module along with their Attribute Tags, types, and descriptions. Note that the Attribute Tags listed in the appendices were chosen only as examples. Any final assignment would rest with the official DICOM committee approving the standard.

Figure 3-2 shows the organization of the Attributes composing ECG Series Module. The heart of ECG Series Module is in the Group Sequence Element, which defines a sequence of zero or more signal group. Each signal group, in turn, is composed of, among other things, a Signal Sequence Element, which defines a sequence of zero or more signal.

### **3.2 ECG Equipment**

The ECG Equipment Module is composed of 6 DICOM Attributes describing the equipment used to obtain the ECG data in this series. Table A.4 in Appendix A.2.2 lists the names of all Attributes in ECG Equipment Module along with their Attribute Tags, types, and descriptions.

### **3.3 ECG Preview**

The ECG Preview Module is composed of 6 DICOM Attributes. Together they provide the "preview" to the entire recording. The purpose of this Module is to provide an efficient way for an ECG reader to select the series that he/she might be interested in exploring further by

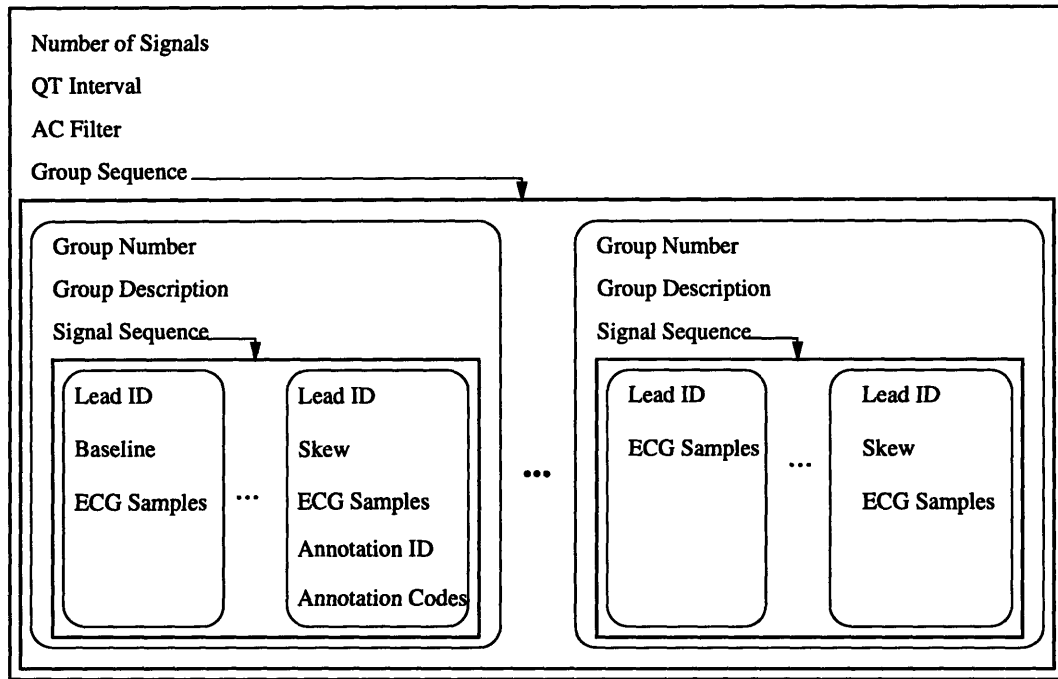

Figure 3-2: ECG Series Module Organization

simply viewing the preview. The data to be included in the Preview Module can either be selected by the diagnosing physician or assigned automatically by the equipment protocols at the time the data are acquired. Using ECG Preview Module, a significant improvement in the retrieval latency can be achieved when the data is obtained over the network since the entire ECG record will not be loaded unless the reader truly so desires.

To allow various preview construction algorithms to be used, this supplement of DICOM imposes no restriction on how one should construct a preview since a set of samples in the middle of the recording can conceivably provide as sufficient a summary of the entire record as those in the beginning or the end. Without such a restriction, the data provider is free to use his/her own judgment rather than being limited by the standard.

The names of all Attributes belonging to ECG Preview Module, together with their Attribute Tags, types and descriptions, can be found in Table A.5 in Appendix A.2.3.

### 3.4 ECG Interpretation

The ECG Interpretation Module is composed of 20 DICOM Attributes. They provide interpretation information relevant to an ECG recording. The interpretation can be applied to an

ECG Series (*i.e.* the ECG signals obtained in one sitting), a signal group or an individual trace by specifying appropriate Referenced Sequences.

The ECG Interpretation Module Attributes are defined using the model suggested by [7] in which an interpretation is expressed by using Interpretation Terms. An Interpretation Term is composed of various Universal ECG Interpretation Codes. For example, LVH\_PR\_AND\_STT\_LV is an interpretation comprising two Interpretation Terms: LVH\_PR and STT\_LV. LVH\_PR is composed of two interpretation codes: LVH (for Left Ventricular Hypertrophy) and PR (for Probable). Similarly, STT\_LV is composed of STT (for ST-T changes) and LV (for compatible with Left Ventricular strain). Combining the two terms with a Conjunction term AND yields the overall meaning of “probable left ventricular hypertrophy with ST-T changes compatible with left ventricular strain.”

One realization of this model is to define an Interpretation Term as a DICOM Sequence containing, among other things, an actual interpretation text (encoded in the Interpretation Term Attribute) and an Interpretation Term’s Instance UID. When a Modifier is applied to an Interpretation Term, it will refer to the term’s Instance UID. Since a Modifier can also modify another Modifier, a Modifier Instance UID is also assigned to each Modifier so that it can be referred to. Other information that can be associated with an Interpretation Term includes a degree of confidence (using Probability Attribute), a Unary Conjunction (such as NOT), and a Binary Conjunction (such as AND) together with a reference to the Interpretation Term with which it is to be combined.

The names of all Attributes belonging to ECG Preview Module, together with their Attribute Tags, types and descriptions can be found in Table A.6 in Appendix A.2.4. The Interpretation Terms included in this appendix were adopted from [7], and thus only represent one scheme of medical nomenclature. Other standards for indexing medical record information, such as the Systematized Nomenclature of Human and Veterinary Medicine (SNOMED), can also be considered as an alternative to the current scheme.

## Chapter 4

# Prototype Implementation

To prove the functionality of the new Information Object Definitions, a prototype implementation that utilizes the proposed DICOM Data Elements has been created. The prototype allows the users to retrieve a set of electrocardiogram data from a source on the network and view it in a useful form. This chapter explains the steps involved in implementing the prototype in detail.

### 4.1 DICOM-Formatted Electrocardiogram Data Generation

In order to generate actual DICOM Data Elements that contain electrocardiogram data and relevant information, a set of ECG records taken from the MIT-BIH Arrhythmia database<sup>[6]</sup> has been converted into DICOM format. Figure 4-1 illustrates the conversion procedure.

Attributes such as annotation, calibration, and ECG recording are retrieved from a record file in the MIT-BIH database using the library routines provided in C Programming Language as described in the ECG Database Programmer's Guide<sup>[5]</sup>. Using these routines, the low-level details of the encoding format adopted by MIT-BIH are abstracted away. Actual data such as sample values and annotation codes can be directly retrieved and written to an output file in the DICOM format as DICOM Elements. These elements are generated using the functions provided by the DICOM C Application Programming Interface (DICOM C API), a library produced by the International Consortium for Medical Imaging Technology (ICMIT). They are used later as the viewer displays the traces and other information in the record.

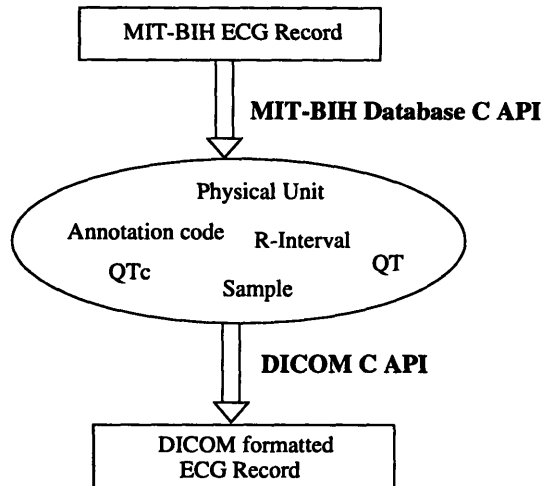

Figure 4-1: Steps involved in converting MIT-BIH database to DICOM

## 4.2 DICOM Electrocardiogram Viewer

The DICOM Electrocardiogram Viewer (DICOM ECG Viewer) provides an easy-to-use interface to manipulate DICOM-formatted electrocardiogram data. Standard operations such as record retrieval and display can be accomplished through simple menu selections. Its distinguished features also include the ability to retrieve an ECG record from anywhere on the Internet.

### 4.2.1 Graphical User Interface

Figure 4-2 shows the graphical user interface of the viewer. It is composed of two major parts: a menu bar and a signal display area. An item on the menu can be selected by simple point-and-click operation of a mouse. The main display area displays the traces data, along with their annotation information, as shown in the figure.

The menu bar of the viewer is composed of three menu items: Load, View, and Help. Selecting each of them will yield the results described below. Note that the screen captures displayed here are obtained from running the viewer on an Intel machine running Windows 95 Operating System. The look-and-feel of the viewer will be different on a different platform. This is a feature provided by `java.awt`, a Java package used in creating the graphical user interface of the viewer.

**Load** The following sub-menus will be displayed when Load menu item is selected.

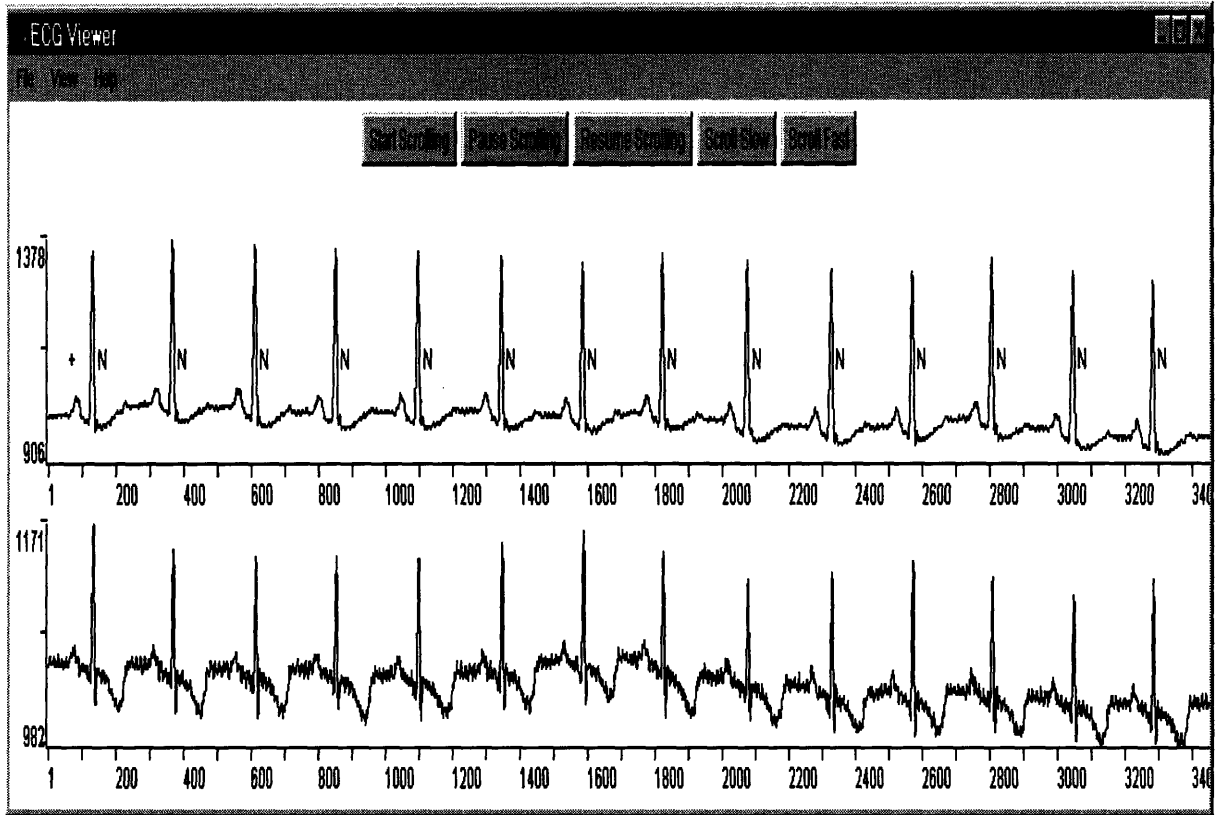

Figure 4-2: Graphical User Interface of the Program

**Load Record** A Load dialog box, as shown in Figure 4-3, will be displayed for the user to type in the Uniform Resource Locator (URL) of the ECG record to be retrieved. While the record is being fetched, the signal display area will show the message “Loading Data, please wait...” until the drawing is finished and displayed.

**Load Preview** A Load Preview dialog box, similar to a Load dialog box, will be displayed to acquire the URL of the ECG record from the user. Only the preview data of the record will be retrieved and displayed in this case. The user can select the sub-menu **Load Preview Record in Full** later if he/she wishes to retrieve the entire record.

**Load Preview Record in Full** The entire record being previewed will be transferred and displayed in the signal display area. If no record is being previewed, a notification message, as shown in Figure 4-4 will be displayed.

**Close** A selection of this sub-menu item closes the current record (*i.e.* the record that is being displayed in the signal display area).



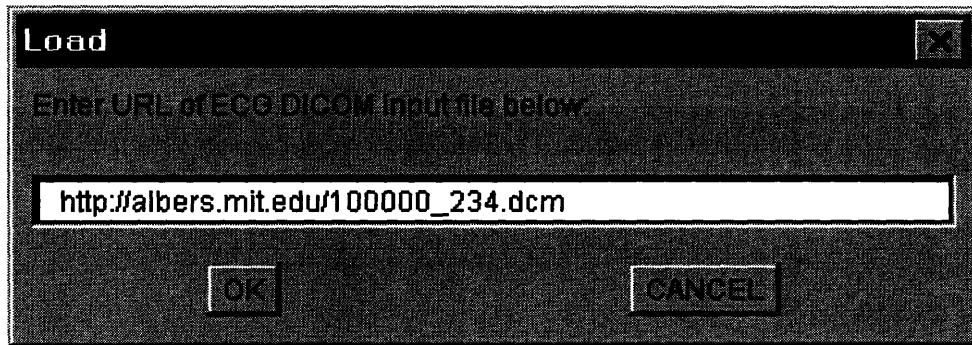

Figure 4-3: Load Dialog Box

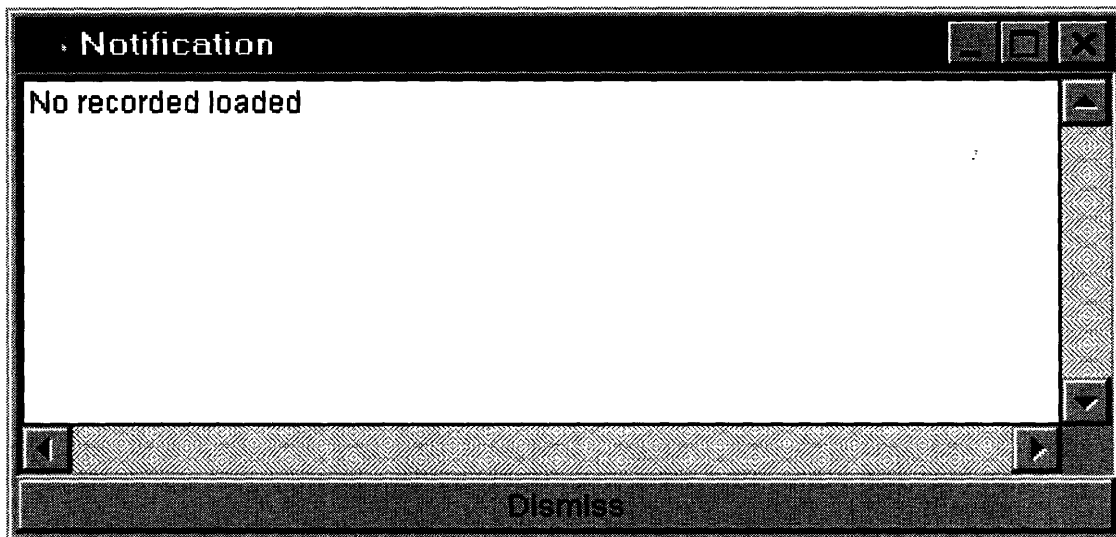

Figure 4-4: Sub-menus of View Menu Item

**Quit** Selecting this item will bring up a dialog box prompting the user for a confirmation to terminate the viewer.

**View** When View menu item is selected, the following sub-menus will be displayed as shown in Figure 4-5.

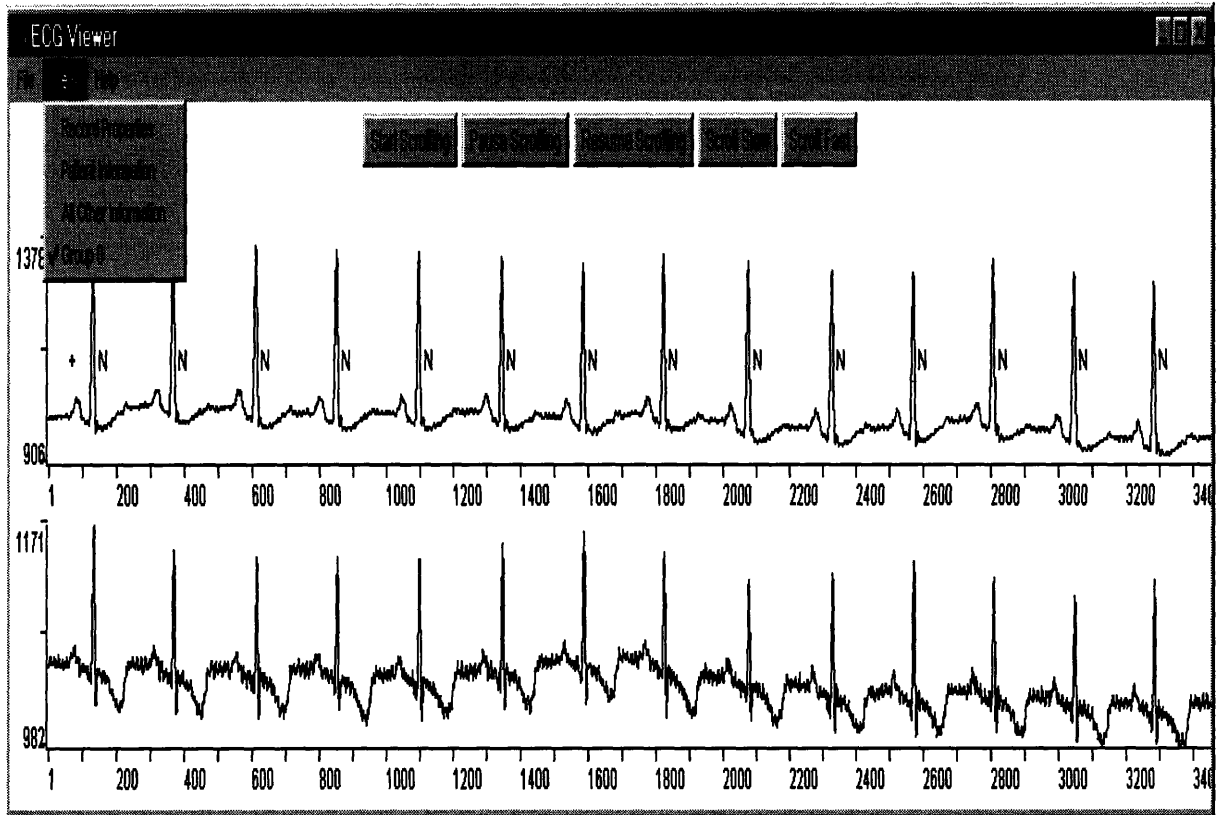

Figure 4-5: Sub-menus of View Menu Item

**Record Properties** A window displaying the properties of this ECG record will be displayed. Clicking the button labeled “Dismiss” located on the bottom of the window will make it disappear.

**Patient Information** A window displaying the information about the patient from whom the ECG record is taken will be displayed. Clicking the button labeled “Dismiss” will close the window.

**All Other Information** A window displaying the information about the record file itself will be displayed. This information will mostly be DICOM related. Clicking the button labeled “Dismiss” will close the window.

**Group List** All items below the three items listed above are the names of all groups contained in the current record. Only one group can be viewed in the signal display area at a time. A check mark in front of the group name indicates which group is being displayed.

**Help** The following sub-menus will be displayed when Help menu item is selected.

**About DICOM ECG Viewer** A window displaying general information about the viewer itself will be display. Clicking the button labeled “Dismiss” will close the window.

**Manual** A window displaying the user manual of the program will be displayed.

The signal display area is where the signal traces are drawn. The buttons provided in the top portion of the area allow the user to control the scrolling of the traces. Clicking the left-mouse button over a signal in the signal display area will bring up a window displaying information related to that particular signal.

## **4.2.2 Implementation**

The DICOM ECG Viewer is implemented in Java, a portable, object-oriented programming language that provides various built-in mechanisms for communication over the Internet. Using the object-oriented framework and networking capabilities provided by Java, DICOM objects can be readily constructed and transferred over a network connection.

The implementation of the DICOM ECG Viewer is based on a client–server model of computation. The server is responsible for answering incoming requests from multiple clients. To assure that a client and the server understand each other, requests from a client and responses from the server must obey a set of rules, called protocol, upon which the communicating parties have agreed beforehand. Section 4.2.2.1 describes the protocol and distribution of responsibilities of a client and the server. The designs and implementation of the server and clients are discussed in section 4.2.2.2 and 4.2.2.3, respectively.

### **4.2.2.1 Client–Server Model and Protocol**

The implementation of the DICOM ECG Viewer is divided into two parts. The first part involves data retrieval and processing. The second deals with the display of processed data

in a format that best serves the user's needs. Consequently, the second part of the system is responsible for handling most of the user's requests through a graphical user interface.

The first and second parts of the system correspond to the server and client applications, respectively. Figure 4-6 illustrates a sample scenario in which a client issues a request to the server for an ECG record.

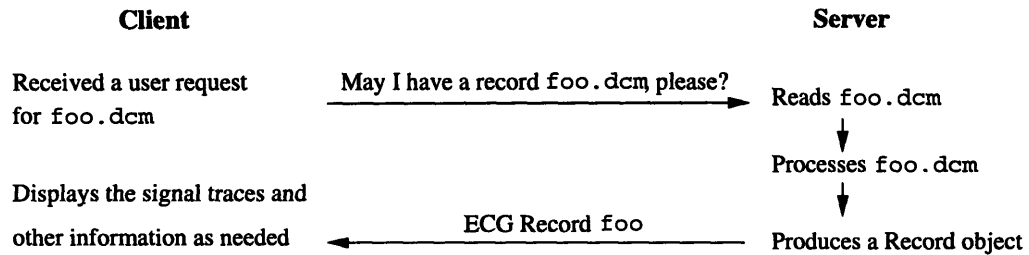

Figure 4-6: A Sample Scenario of an Interaction between a Client and the Server

Using a Transmission Control Protocol (TCP) Socket object provided by the `java.net` package, the low-level operations involved in establishing a connection between a client and the server can be abstracted away. As a result, the protocol governing the communication between them is largely simplified. Figure 4-7 shows all possible client's requests and their corresponding responses from (and actions performed by) the server.

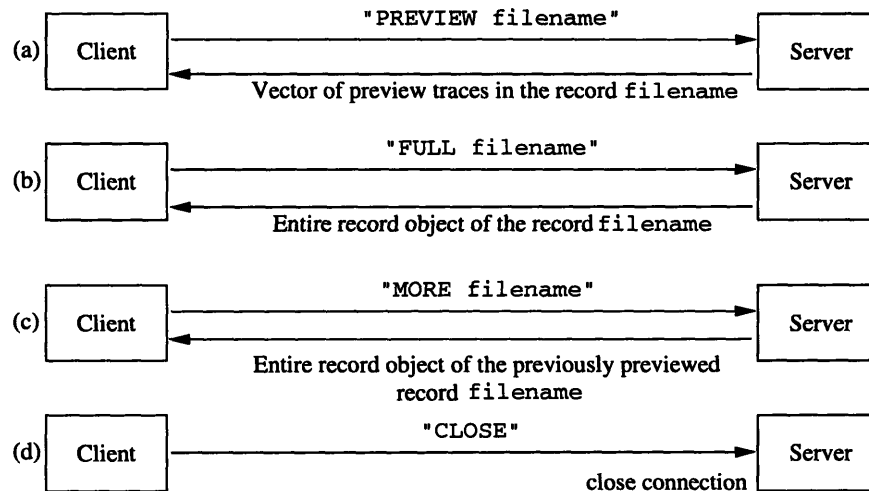

Figure 4-7: Client and Server Communication Protocol

In Figure 4-7, the text in quotation marks above the arrows pointing from left to right are commands sent by the client. They indicate the client's requests. The text below the arrows pointing from right to left are replies sent by the server in response to the client's requests.

For example, in Figure 4-7(a), the client sends the command “PREVIEW filename” (where filename is the name of a DICOM formatted file) to the server, indicating its wishes to obtain preview information of the ECG record in the file called filename. The server then replies by transmitting a Java Vector object containing the preview traces in the requested record back to the client. There are a total of four possible patterns of communication specified in the protocol. Improperly formatted commands or responses will be ignored by the receiving end of the communication.

#### 4.2.2.2 Server Design and Implementation

The server application is composed of two main objects: a “Server” and a “Babysitter.” A Server object is an active object that continuously waits for incoming connections from its clients. Once the Server object receives a request to connect, it creates a Babysitter object, yields the socket, which is an object containing the incoming and outgoing streams for the newly-established connection, to the Babysitter object, and continues waiting for the next connection. The Babysitter object will “baby-sit” the connection that it has been given by responding to its client’s requests coming in through its socket’s inputstream.

As a result, most activities take place inside the Babysitter object. Different actions are performed according to the client’s requests. Table 4.1 describes the Babysitter object’s actions and responses corresponding to the client’s requests.

Table 4.1: Client’s Requests and Babysitter’s Actions and Responses

Client’s Request	meaning	Babysitter’s Actions/Responses
PREVIEW filename	Preview traces of the record filename is requested.	Read filename. Construct a Record object and send a Vector of its preview lead objects through the outputstream if possible. Otherwise, send an exception instead.
FULL filename	The entire record filename is requested.	Read filename. Construct and send a Record object through the outputstream if possible. Otherwise, send an exception instead.
MORE filename	The rest of a previously-previewed record filename is requested.	Send a Record object through the outputstream if the preview of the record has, in fact, been requested. Otherwise, send an error message describing the problem instead.
CLOSE	The client wishes to close the connection.	Close the connection.

### 4.2.2.3 Client Design and Implementation

The client is designed to function both as an application and as a Java applet.<sup>1</sup> To execute the client program as an application, one must use the Java interpreter distributed in the Java Developers Kit (JDK) version 1.1 or later. To run the program as an applet, one can use either an appletviewer (also provided in the JDK) or a web browser to download the program as long as the appletviewer or the web browser supports the classes provided in the API version 1.1 or later.

The client is composed of four main components: ClientApp, GUI, Command and ECGViewport.

The ClientApp class is the core of the client application. It is responsible for communicating with the server in response to the user's demands. A GUI object handles the display of dialog windows and menus with which the user interacts. A Command object dispatches the requests coming in from the Graphical User Interface (GUI) to appropriate components of the application that knows how to handle them. Finally, an ECGViewport object deals with the intricacies of displaying the signal traces and annotations. Other components are used to facilitate the tasks of these four main components and, thus, not mentioned here. The relationships and interactions among the four components are illustrated in Figure 4-8.

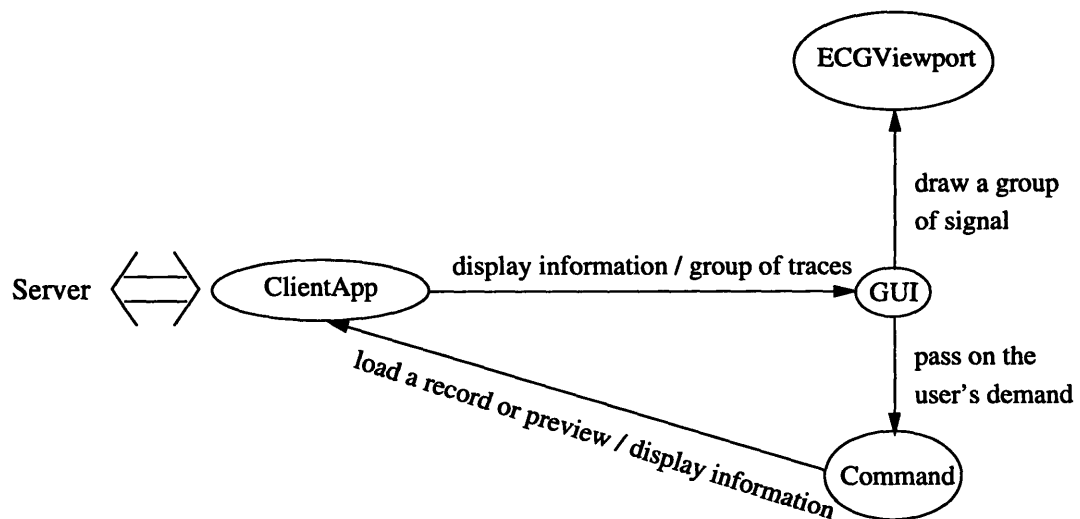

Figure 4-8: Relationships among ClientApp, GUI, Command and ECGViewport

<sup>1</sup>A Java applet is a Java program that can be embedded inside an HTML document. It will start executing automatically as its containing document is retrieved. This property allows the program to be retrieved and executed from anywhere on the Internet.

### **4.3 How to Acquire the ECG Viewer**

The source code and documentation of the DICOM ECG Viewer is available to members of the International Consortium of Medical Imaging Technology at <http://icmit.mit.edu>. To run the viewer, one needs either a web browser, an appletviewer or a Java interpreter that supports Java packages provided in the API version 1.1 or later.

## Chapter 5

# Conclusions

The prototype implementation of the DICOM Electrocardiogram Viewer demonstrates that the new Information Object Definitions and Modules provide effective encapsulation of real electrocardiogram data. The ability to retrieve and display an ECG recording from anywhere on the Internet also opens up many areas of potential applications especially in the field of telemedicine. Physicians will be able to review an ECG recording on demand even when they are away from the hospital without relying on paper or FAX, which are inferior to digital records in quality. The importance of having electrocardiogram data from previous examinations available to emergency personnel in case of a heart attack or an accident should be apparent. Finally, with appropriate timing “glue” software, it should be possible to synchronize ECG data with other image modalities such as Ultrasound to create composite or “overlay” views of cardiac function.

The supplements to the DICOM standard that are required in order to add a support for electrocardiogram data also show that DICOM is an extensible standard. Adding supports for new modalities requires no change to the existing components of the standard. Only a few addenda are needed in a few parts of the standard to accommodate the new IODs and Modules.



# Appendix A

## Part 3 Addendum

### Electrocardiogram Information

### Object Definitions

#### A.1 Addendum to Annex A of Part 3 of the DICOM Standard

There are two proposed Modules to be added to Annex A of Part 3 of the DICOM standard.

## **A.1.1 Proposed ECG Signal Information Object Definition**

### **A.1.1.1 ECG Signal Information Object Definition Description**

The purpose of the Electrocardiogram Signal Information Object Definition (ECG-S IOD) is to address the requirements for electrocardiogram data transfer.

### **A.1.1.2 ECG Signal Information Object Definition Module Table**

ECG-S IOD is composed of 11 Modules listed in Table A.1.

Table A.1: ECG-S IOD Modules

<b>IE</b>	<b>Module</b>	<b>Reference</b>	<b>Usage</b>
Patient	Patient	C.7.1.1	M
Study	General Study	C.7.2.1	M
	Patient Study	C.7.2.2	U
Series	General Series	C.7.3.1	M
	ECG Series	A.2.1	M
Equipment	General Equipment	C.7.5.1	M
	ECG Equipment	A.2.2	M
Overlay	Overlay Plane	C.9.2	U
Curve	Curve Identification	C.10.1	M
	ECG Preview	A.2.3	U
	SOP Common	C.12.1	M

## **A.1.2 Proposed ECG Interpretation Information Object Definition**

### **A.1.2.1 ECG Interpretation Information Object Definition Description**

The purpose of the Electrocardiogram Interpretation Information Object Definition is to address the requirements for electrocardiogram interpretation data transfer.

### **A.1.2.2 ECG Interpretation Information Object Definition Module Table**

ECG-I IOD is composed of 10 Modules listed in Table A.2.

Table A.2: ECG Interpretation Information Object Definition Modules

<b>IE</b>	<b>Module</b>	<b>Reference</b>	<b>Usage</b>
Patient	Patient	C.7.1.1	M
Study	General Study	C.7.2.1	M
	Patient Study	C.7.2.2	U
Series Equipment	General Series	C.7.3.1	M
	General Equipment	C.7.5.1	M
	ECG Equipment	A.2.2	U
Overlay	Overlay Plane	C.9.2	U
	ECG Preview	A.2.3	U
	ECG Interpretation	A.2.4	M
	SOP Common	C.12.1	M

## **A.2 Addendum to Annex C of Part 3 of the DICOM Standard**

### **A.2.1 Proposed ECG Series Module**

Each Attribute in a Module Definition is given a name and type. There exist five possible Attribute types in the DICOM standard:

- Type 1 means that a value for the corresponding Attribute is required.
- Type 1C means the value for the corresponding Attribute is required when a certain condition is met.
- Type 2 means that a value for the corresponding Attribute is required if known. If the value is not known, only the Attribute tag is required. The value can be skipped.
- Type 2C is required in the same way type 2 does only when a certain condition is met.
- Type 3 means the value for the corresponding Attribute is optional.

Some Attributes will be constrained to take on values taken from a pre-defined set of possible values. The terms “Enumerated Value” and “Defined Term” are used to distinguish between two types of these values. Enumerated Values are used when the specified values are the only values allowed for a Data Element. Defined Terms are used when the specified values may be extended by implementors to include additional new values.

Each Attribute Tag is composed of a Group Tag followed by an Element Tag, each of which is a hexadecimal number. A private Module is associated with an odd Group Tag. A public Module is associated with an even Group Tag. The Modules provided in this appendix are assigned odd Group Tags to indicate that their Elements are private for the time being. These Group Tags will be changed to a set of even numbers as approved by the DICOM committee.

The ECG Series Module Attributes are listed in Table A.3. They provide the information relevant to one ECG report. Note that each “>” sign in front of an Attribute name indicates that this Attribute is an item embedded in the closest sequence Attribute preceding it. Hence, an item embedded in a sequence that is, in turn, embedded in another sequence, will be preceded by a “>>” sign.

Table A.3: ECG Series Module

Attribute Name	Tag	Type	Attribute Description
Number of Signals	(0003, 0001)	1	Number of leads recorded in the series
Rate	(0003, 0002)	3	Heart Rate (beats per minute)
PR	(0003, 0003)	3	PR interval (milliseconds)
QRSD	(0003, 0004)	3	QRS duration (milliseconds)
QT	(0003, 0005)	3	QT interval (milliseconds)
QTc	(0003, 0006)	3	QT interval corrected for rate (milliseconds)
P-Axis	(0003, 0007)	3	Frontal P axis (degrees)
QRS-Axis	(0003, 0008)	3	Frontal mean QRS axis (degrees)
T-Axis	(0003, 0009)	3	Frontal T axis (degrees)
AC Filter	(0003, 000A)	3	AC filter used (Hz). Usually 50 or 60 Hz.
Bandpass Filter Sequence	(0003, 000B)	3	Define a sequence of zero or more filter.
>Low Cutoff Frequency	(0003, 000C)	3	Low cutoff frequency of the filter. If omitted, the default is $-\infty$
>High Cutoff Frequency	(0003, 000D)	3	High cutoff frequency of the filter. If omitted, the default is $+\infty$
Notch Filter Sequence	(0003, 000E)	3	Define a sequence of zero or more filter.
>Notch Filter Low Cutoff Frequency	(0003, 000F)	3	Low cutoff frequency of the notch filter.
>Notch Filter High Cutoff Frequency	(0003, 0010)	3	High cutoff frequency of the notch filter.
Limb Sensitivity	(0003, 0011)	3	Limb sensitivity (mm/mV)
Chest Sensitivity	(0003, 0012)	3	Chest sensitivity (mm/mV)
Base Sampling Frequency	(0003, 0013)	1	The base sampling frequency (Samples per second). It is the same for all signals in a given series.
Counter Frequency	(0003, 0014)	3	The difference between counter values that are one second apart. It is the same for all signals in a given series.
Base Counter Value	(0003, 0015)	1	The counter value corresponding to first sample in the signal
Base Date and Time	(0003, 0016)	3	The date and time of day for sample 0. It is 0/0/0 0:00 (midnight) if omitted.

Table A.3. ECG Series Module (Continued)

Attribute Name	Tag	Type	Attribute Description
Group Sequence	(0003, 0017)	3	Define a sequence of zero or more group.
>ECG Group Number	(0003, 0018)	2	A number that identifies this ECG group.
>Group Description	(0003, 0019)	3	Description/Comments for this signal group.
>Number of Signals	(0003, 001A)	3	Number of signals in this group.
>ECG Signal Sequence	(0003, 001B)	1	Define a sequence of zero or more ECG signal.
>>Calibration Pulse Shape	(0003, 001C)	1	The shape of the calibration pulse. See A.2.1.1.1 for Defined Terms.
>>Calibration Peak-to-Peak Amplitude	(0003, 001D)	1	The peak-to-peak amplitude (in physical units) of the calibration pulse.
>> Physical Unit	(0003, 001E)	3	Physical unit of the signal. It is millivolt (MV) if omitted.
>> Trace Number	(0003, 001F)	2	A number that identifies this ECG trace.
>> Lead Identification	(0003, 0020)	1	Type of lead used to record the signal. See A.2.1.1.2 for Defined Terms.
>> Signal Description	(0003, 0021)	3	Description/comments for this trace.
>> Samples per Frame	(0003, 0022)	3	Number of samples per frame.
>> Number of Samples	(0003, 0023)	3	Number of samples in the signal.
>> Skew	(0003, 0024)	3	Number of samples that precede sample 0 in time.
>> ADC Resolution	(0003, 0025)	1	The resolution of the analog-to-digital converter used to digitize the signal.
>> ADC Zero	(0003, 0026)	3	The value produced by the analog-to-digital converter given a 0 volt input. It is 0 if omitted.
>> ADC Gain	(0003, 0027)	3	Number of Analog-to-Digital converter Units (adus) per physical unit of the samples in the signal. It is 200 if omitted.
>> Baseline	(0003, 0028)	3	Sample value that is equivalent to 0 physical units. It is the same as ADC zero if omitted.

Table A.3. ECG Series Module (Continued)

Attribute Name	Tag	Type	Attribute Description
>> P-duration	(0003, 0029)	3	Total P-duration, including P+ and P- component (milliseconds)
>> PR-interval	(0003, 002A)	3	PR-interval (milliseconds)
>> QRS-duration	(0003, 002B)	3	QRS-duration (milliseconds)
>> QT-interval	(0003, 002C)	3	QT-interval (milliseconds)
>> Q-duration	(0003, 002D)	3	Q-duration (milliseconds)
>> R-duration	(0003, 002E)	3	R-duration (milliseconds)
>> S-duration	(0003, 002F)	3	S-duration (milliseconds)
>> R'-duration	(0003, 0030)	3	R'-duration (milliseconds)
>> S'-duration	(0003, 0031)	3	S'-duration (milliseconds)
>> Q-amplitude	(0003, 0032)	3	Q-amplitude (microvolts)
>> R-amplitude	(0003, 0033)	3	R-amplitude (microvolts)
>> S-amplitude	(0003, 0034)	3	S-amplitude (microvolts)
>> R'-amplitude	(0003, 0035)	3	R'-amplitude (microvolts)
>> S'-amplitude	(0003, 0036)	3	S'-amplitude (microvolts)
>> J-point-amplitude	(0003, 0037)	3	Amplitude of the J-point = amplitude of the end of QRS (microvolts)
>> P(+)-amplitude	(0003, 0038)	3	P(+)-amplitude (microvolts)
>> P(-)-amplitude	(0003, 0039)	3	P(-)-amplitude (microvolts)
>> T(+)-amplitude	(0003, 003A)	3	T(+)-amplitude (microvolts)
>> T(-)-amplitude	(0003, 003B)	3	T(-)-amplitude (microvolts)
>> ST-slope	(0003, 003C)	3	ST-slope (microvolts per second)
>> QT Dispersion	(0003, 003D)	3	QT dispersion.
>> P morphology	(0003, 003E)	3	P morphology. See A.2.1.1.3 for Enumerated Values.
>> T morphology	(0003, 003F)	3	T morphology. See A.2.1.1.3 for Enumerated Values.
>> Onset Iso-electric segment	(0003, 0040)	3	Iso-electric segment at onset of QRS in milliseconds (Segment I). See A.2.1.1.4 for details.
>> End Iso-electric segment	(0003, 0041)	3	Iso-electric segment at the end of QRS in milliseconds (Segment K). See A.2.1.1.4 for details.
>> Intrinsicoid deflection	(0003, 0042)	3	Intrinsicoid deflection (milliseconds)
>> Quality	(0003, 0043)	3	Quality code reflecting ECG recording conditions. See A.2.1.1.5 for Defined Terms.
>> Noise	(0003, 0044)	3	The severity of artifact in the signal data. See A.2.1.1.6 for Defined Terms.

Table A.3. ECG Series Module (Continued)

Attribute Name	Tag	Type	Attribute Description
>> ST20	(0003, 0045)	3	ST-amplitude at the J-point plus 20 milliseconds
>> ST60	(0003, 0046)	3	ST-amplitude at the J-point plus 60 milliseconds
>> ST80	(0003, 0047)	3	ST-amplitude at the J-point plus 80 milliseconds
>> ECG Samples	(0003, 0048)	1C	ECG sample values. Required if ECG Signal Sequence is sent.
>> Annotator's Identifier	(0003, 0049)	3	Annotator's Identifier.
>> Annotation Codes	(0003, 004A)	1C	Annotation codes. Required if Annotator's Identifier is sent. See A.2.1.1.7 for Defined Terms.

### A.2.1.1 Description

#### A.2.1.1.1 Calibration Pulse Shape

The Defined Terms for Calibration Pulse Shape Attribute are as follows<sup>[5]</sup>:

SQUARE = Square wave pulse

SINE = Sine wave pulse

SAWTOOTH = Sawtooth pulse

#### A.2.1.1.2 Lead Identification

A lead identification is the name of the lead that produces the corresponding ECG trace. Defined Terms for the Lead Identification Attribute are I (for Einthoven lead one), II, V1, V2, V3, V4, V5, V6, V7, V2R, V3R, V4R, V5R, V6R, V7R, X, Y, Z, CC5, CM5, Left Arm, Right Arm, Left Leg, FI (for Frank electrode I), E, C, A, M, F, H, EI-cal, II-cal, V1-cal, V2-cal, V3-cal, V4-cal, V5-cal, V6-cal, V7-cal, V2R-cal, V3R-cal, V4R-cal, V5R-cal, V6R-cal, V7R-cal, X-cal, Y-cal, Z-cal, CC5-cal, CM5-cal, Left Arm-cal, Right Arm-cal, Left Leg-cal, FI-cal, E-cal, C-cal, A-cal, M-cal, F-cal, H-cal, III, aVR, aVL, aVF, and aVR<sup>[7]</sup>.

#### A.2.1.1.3 P and T Morphology

The possible P and T morphology types are shown in Figure A-1<sup>[7]</sup>.



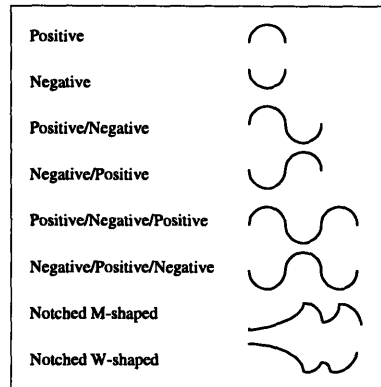

Figure A-1: Possible P and T Morphology Types

#### A.2.1.1.4 Iso-electric Segments

Segment I is the interval between the global onset of QRS derived from all simultaneously recorded leads and the onset of QRS in a specific lead. Conversely, Segment K is the time between the end of QRS in a specific lead and the global end of QRS<sup>[7]</sup>.

#### A.2.1.1.5 Quality

Quality Attribute indicates the type of noise present in the lead. Its Defined Terms are as follows<sup>[2]</sup>:

- D = Baseline wander indicator. The onset of two successive QRS complexes differ by more than 1/3 calibration value.
- T = Artifact, most likely muscle tremor. Occurs when more than 16 up-and-down strokes exceeding 1 millimeter amplitude are detected within 1 second.
- W = Steady baseline drift exceeding 10 millimeters per second.
- A = Power line (AC) noise.
- M = Missing lead.
- O = Overrange.
- S = Spikes or sudden jumps.
- P = Pacemaker.
- I = Interchanged lead.

#### A.2.1.1.6 Noise

Noise Attribute indicates the severity of artifact reflected in the ECG trace. Defined Terms

are light, moderate, marked, and severe<sup>[7]</sup>.

#### **A.2.1.1.7 Annotation Codes**

An annotation is a description associated with each beat in the rhythm data. For example, a beat annotation indicates whether a particular beat is a normal, left bundle branch block, or right bundle branch block beat. There exist many terms used in the field of electrocardiography to describe a beat. Each of these terms can be assigned an annotation code to be used in labeling a sample in an ECG trace. Defined Terms for annotation codes are as follows<sup>[7]</sup>:

- = Normal beat
- L = Left bundle branch block beat
- R = Right bundle branch block beat
- A = Atrial premature beat
- a = Aberrated atrial premature beat
- J = Nodal (junctional) premature beat
- S = Supraventricular premature beat
- V = Premature ventricular contraction
- F = Fusion of ventricular and normal beat
- [ = Start of ventricular flutter/fibrillation
- ! = Ventricular flutter wave
- ] = End of ventricular flutter/fibrillation
- e = Atrial escape beat
- j = Nodal (junctional) escape beat
- E = Ventricular escape beat
- P = Paced beat
- f = Fusion of paced and normal beat
- p = Non-conducted P-wave (blocked APB)
- Q = Unclassifiable beat
- l = Isolated QRS-like artifact
- (AB = Atrial bigeminy
- (AFIB = Atrial fibrillation
- (AFL = Atrial flutter
- (B = Ventricular bigeminy

(BII = 2° heart block  
(IVR = Idioventricular rhythm  
(N = Normal sinus rhythm  
(NOD = Nodal (A-V junctional) rhythm  
(P = Paced rhythm  
(PREX= Pre-excitation (WPW)  
(SBR = Sinus bradycardia  
(SVTA = Supraventricular tachyarrhythmia  
(T = Ventricular trigeminy  
(VFL = Ventricular flutter  
(VT = Ventricular tachycardia  
c = Signal quality changes from noisy to clear  
n = Signal quality changes from clear to noisy  
U = Extreme noise or signal loss in both signals: ECG is unreadable  
M = Missed beat  
P = Pause  
T = Tape slippage

### A.2.2 Proposed ECG Equipment Module

Table A.4 lists the names of all Attributes in ECG Equipment Module along with their Attribute Tags, types and descriptions.

Table A.4: ECG Equipment Module

<b>Attribute Name</b>	<b>Tag</b>	<b>Type</b>	<b>Attribute Description</b>
Device Type	(0005, 0001)	3	Cart or system (host)
Printing Capability	(0005, 0002)	3	Indicates whether the equipment can print an ECG report
Interpreting Capability	(0005, 0003)	3	Indicates whether the equipment can interpret an ECG report
Storage Capability	(0005, 0004)	3	Indicates (in bytes) the storage capability of the equipment
Acquisition Capability	(0005, 0005)	3	Indicates whether the equipment can acquire ECG data
AC Main Frequency Environment	(0005, 0006)	3	AC frequency (Hz) of the environment

### A.2.3 Proposed ECG Preview Module

Table A.5 lists the names of all Attributes in ECG Preview Module along with their Attribute Tags, types and descriptions.

Table A.5: ECG Preview Module

<b>Attribute Name</b>	<b>Tag</b>	<b>Type</b>	<b>Attribute Description</b>
Start Time	(0007, 0015)	1	Sample value of the first sample in the preview
Preview Signal Sequence	(0007, 001B)	1	Define a sequence of zero or more preview signals.
> Number of Samples	(0007, 0023)	1C	Number of samples in this preview signal. Required if Preview Signal Sequence is sent.
> Preview Samples	(0007, 0048)	1C	Preview sample values. Required if Preview Signal Sequence is sent.
> Annotator's Identifier	(0007, 0049)	3	Annotator's identifier
> Annotation Codes	(0007, 004A)	3	Annotation codes. See A.2.1.1.7 for Defined Terms.

## A.2.4 Proposed ECG Interpretation Module

Table A.6 lists the names of all Attributes in ECG Interpretation Module along with their Attribute Tags, types and descriptions.

Table A.6: ECG Interpretation Module

Attribute Name	Tag	Type	Attribute Description
Referenced ECG Series Sequence	(0009, 0001)	1	Uniquely identifies the Series SOP Instances from which the ECG Interpretation is derived.
> Referenced SOP class UID	(0008, 1150)	1	Uniquely identifies the referenced SOP Class.
> Referenced SOP Instance UID	(0008, 1155)	1	Uniquely identifies the referenced SOP Instance.
Referenced ECG Group Sequence	(0009, 0002)	3	Uniquely identifies the ECG Group SOP Instances from which the ECG Interpretation is derived.
> Referenced SOP class UID	(0008, 1150)	1C	Uniquely identifies the referenced SOP Class. Required if Referenced ECG Group Sequence is sent.
> Referenced SOP Instance UID	(0008, 1155)	1C	Uniquely identifies the referenced SOP Instance. Required if Referenced ECG Group Sequence is sent.
Referenced Trace Sequence	(0009, 0003)	3	Uniquely identifies the Trace SOP Instances from which the ECG Interpretation is derived.
> Referenced SOP class UID	(0008, 1150)	1C	Uniquely identifies the referenced SOP Class. Required if Referenced Trace Sequence is sent.
> Referenced SOP Instance UID	(0008, 1155)	1C	Uniquely identifies the referenced SOP Instance. Required if Referenced Trace Sequence is sent.
ECG Interpretation Term Sequence	(0009, 0004)	1	Define a sequence of zero or more ECG Interpretation Term.
> Interpretation Term ID	(0009, 0005)	1	Uniquely identifies the Interpretation Term.
> Interpretation Term	(0009, 0006)	1	The actual interpretation text. See A.2.4.1.1 for Defined Terms.

Table A.6. ECG Interpretation Module

Attribute Name	Tag	Type	Attribute Description
> Probability	(0009, 0007)	3	The estimated probability that the Interpretation Term is correct. See A.2.4.1.2 for Defined Terms.
> Unary Conjunction	(0009, 0008)	3	A conjunctive term that only applies to this Interpretation Term. See A.2.4.1.3 for Defined Terms.
> Binary Conjunction	(0009, 0009)	3	A conjunctive term that describes a relationship between two Interpretation Terms. See A.2.4.1.4 for Defined Terms.
> Referenced Interpretation Term	(0009, 000A)	1C	Required if Binary Conjunction is sent.
Modifier Sequence	(0009, 000B)	3	Define a sequence of zero or more Modifier.
> Modifier ID	(0009, 000C)	1C	ID of this Modifier. Required if Modifier Sequence is sent.
> Referenced Term ID	(0009, 000D)	1C	ID of the term this Modifier modifies. This term can be either another Modifier or an ECG Interpretation Term. Required if Modifier Sequence is sent.
> Modifier Term	(0009, 000E)	1C	The actual modifier text. See A.2.4.1.5 for Defined Terms.

### A.2.4.1 Description

#### A.2.4.1.1 Interpretation Term

The following list contains Defined Terms and associated meanings for Interpretation Term Attribute. They are largely extracted from [7].

#### Normal/Abnormal

NORM	normal ECG
NLECG	normal ECG
NLQRS	normal QRS
NLP	normal P wave
NLSTT	normal ST-T
WHNOR	ECG within normal limits for age and sex
POSNL	possibly normal ECG

BOECG	borderline ECG
ABECG	abnormal ECG
POSAB	possibly abnormal ECG
ABQRS	abnormal QRS
ABSTT	abnormal ST-T
NFA	normal for age
NFB	normal for build
ABFA	abnormal for age
ABFB	abnormal for build
UFB	unusual for build

#### Ventricular Hypertrophy

LVH	left ventricular hypertrophy
VCLVH	voltage criteria (QRS) for left ventricular hypertrophy
RVH	right ventricular hypertrophy
VCRVH	voltage criteria (QRS) for right ventricular hypertrophy
BVH	biventricular hypertrophy
SEHYP	septal hypertrophy
PRANT	prominent anterior forces

#### Myocardial Infarction

MI	myocardial infarction
AMI	anterior myocardial infarction
ASMI	anteroseptal myocardial infarction
ALMI	anterolateral myocardial infarction
LMI	lateral myocardial infarction
HLMI	high-lateral myocardial infarction
APMI	apical myocardial infarction
IMI	inferior myocardial infarction
ILMI	inferolateral myocardial infarction
IPMI	inferoposterior myocardial infarction
IPLMI	inferoposterolateral myocardial infarction



PMI posterior myocardial infarction

Conduction disturbances

BBB unspecified bundle branch block  
CLBBB complete left bundle branch block  
ILBBB incomplete left bundle branch block  
ALBBB atypical left bundle branch block  
CRBBB complete right bundle branch block  
IRBBB incomplete right bundle branch block  
IVCD non-specific intraventricular conduction disturbance (block)  
IVCD> intraventricular conduction disturbance (QRS>120ms)  
IVCD< minor intraventricular conduction disturbance (QRS<120ms)  
WPW Wolf-Parkinson-White syndrome  
WPWA Wolf-Parkinson type A  
WPWB Wolf-Parkinson type B  
PREEX pre-excitation  
LAFB left anterior fascicular block  
LPFB left posterior fascicular block  
BIFAS bifascicular block (its two components shall always be listed separately)  
TRFAS trifascicular block

Other QRS morphology or general descriptive statements

COPD ECG consistent with chronic obstructive pulmonary disease  
PE pulmonary emphysema  
QWAVE Q waves present  
POORR poor R-wave progression in precordial leads  
ABRPR abnormal R-wave progression  
PROMR prominent R waves in right precordial leads  
DXTRO dextrocardia  
LVOLT low QRS voltages in the frontal and horizontal leads  
HVOLT high QRS voltage  
LVOLF low voltage in frontal leads

LVOLH	low QRS voltages in the horizontal leads
HVOLF	high QRS voltages in the frontal leads
HVOLH	high QRS voltage in the horizontal leads
S1S23	S1 S2 S3 type QRS pattern
RSR1	rSr type in V1 V2
TRNZL	Transition zone in precordial leads displaced to the left
TRNZR	Transition zone in precordial leads displaced to the right
MYOPA	compatible with cardiomyopathy
MYOCA	compatible with myocarditis
CRIMA	criteria for
CRIMO	moderate criteria for
CRIMI	minimal criteria for

Rhythm statements related to impulse formation (abnormalities)

SR	sinus rhythm
NSR	normal sinus rhythm
SARRH	sinus arrhythmia
MSAR	marked sinus arrhythmia
SVARR	supraventricular arrhythmia
STACH	sinus tachycardia
ETACH	extreme tachycardia
SBRAD	sinus bradycardia
EBRAD	extreme bradycardia
JTACH	junctional tachycardia
SVTAC	supraventricular tachycardia
JBRAD	junctional bradycardia
SVBRA	supraventricular bradycardia
WQTAC	wide QRS tachycardia
NQTAC	narrow QRS tachycardia
TACHO	tachycardia, origin unknown or not specified
BRADO	bradycardia, origin unknown or not specified
ARRHY	arrhythmia, origin unknown

IRREG	irregular rhythm
REGRH	regular rhythm
JESCR	junctional escape rhythm
VESCR	ventricular escape rhythm
ACAR	accelerated atrial rhythm
ACVR	accelerated ventricular rhythm
ACJR	accelerated junctional rhythm
AVJR	AV-junctional rhythm
ARHYT	atrial rhythm
SVRHY	supraventricular rhythm
JRHYT	junctional rhythm
VRHYT	ventricular rhythm
UNRHY	undetermined rhythm
EAR	ectopic atrial rhythm
LAR	left atrial rhythm
MAR	multifocal atrial rhythm
NODRH	nodal rhythm
RAR	low right atrial rhythm
LGL	Lown-Ganong-Levine syndrome
SHTPR	Short PR-interval
AFIB	atrial fibrillation
AFLT	atrial flutter
ATACH	atrial tachycardia
PSVT	paroxysmal supraventricular tachycardia
PAT	paroxysmal atrial tachycardia
MFAT	multifocal atrial tachycardia
RATAC	run of atrial tachycardia
RJTAC	run of junctional tachycardia
AVNRT	atrioventricular nodal re-entrant tachycardia
AVRT	atrioventricular reciprocating tachycardia
IDIOR	idioventricular rhythm
VFIB	ventricular fibrillation

VTACH	ventricular tachycardia
RVTAC	run of ventricular tachycardia
SVT	sustained ventricular tachycardia
NSVT	non-sustained ventricular tachycardia
TORSA	torsade des pointes ventricular tachycardia
MTACH	multifocal tachycardia (multiform), supraventr, or ventricular
VFLT	ventricular flutter
ASYST	asystole

Rhythm statements related to sinus node dysfunction, atrial and A V-conduction defects

1AVB	first degree A V block
2AVB	second degree A V block
3AVB	third degree A V block
I2AVB	intermittent second degree A V block
A2AVB	alternating second degree A V block
AVDIS	A V-dissociation
WENCK	Wenckebach phenomenon
MOBI2	Mobitz type 2 second degree A V block
SAR	sinus arrest
SARA	sinus arrest with atrial escape
SARSV	sinus arrest with supraventricular escape
SARJ	sinus arrest with junctional escape
SARV	sinus arrest with ventricular escape
SABLK	sino-atrial block
SPAUS	sinus pause
WANDP	wandering pacemaker
LRR	long R-R interval measured
OCAP	occasional capture

Rhythm statements related to ectopic rhythm abnormalities

PRC(S)	premature complex(es)
PAC or APC (APB)	atrial premature complex (beat)

	(use of APB is not recommended)
BPAC	blocked premature atrial contraction
MAPCS	multiple atrial premature complexes
PVC or VPC (VPB)	ventricular premature complex (beat)
	(use of VPB is not recommended)
MVPCS	multiple premature ventricular complexes
RVPCS or RPVCS	run of ventricular premature complexes
RAPCS	run of atrial premature complexes
RJPCS	run of junctional premature complexes
VIC	ventricular interpolated complexes
MVICS	multiple ventricular interplated complexes
MICS	multiple interpolated complexes
SVPC	supraventricular premature complex
SVPCS	(multiple) supraventricular premature complexes
SVIC(S)	supraventricular interpolated complex(es)
ABER(S)	aberrantly conducted complex(es)
ABPCS	aberrant premature complexes, origin unknown
ABSVC	aberrant complex, possibly supraventricular origin
ABSVS	aberrant complexes, possibly supraventricular origin
ABASH	aberrant supraventricular complexes of the Ashman type
JPC(S)	junctional premature complex(es)
MJPCS	multiple junctional premature complexes
PVPCS or PPVCS	paired ventricular premature complexes
PAPCS	paired atrial premature complexes
PJPCS	paired junctional premature complexes
OVPAC	occasional ventricular paced complexes
ONPAC	occasional non-paced complexes
VBIG	ventricular bigeminy
ABIG	atrial bigeminy
SVBIG	supraventricular bigeminy
BIGU	bigeminy pattern (unknown origin, SV, or Ventricular)
FUSC(S)	fusion complex(es)

CAPT(S)	capture complex(es)
VEC(S)	ventricular escape complex(es)
AEC(S)	atrial escape complex(es)
SVEC(S)	supraventricular escape complex(es)
JEC(S)	junctional escape complex(es)
ESCUN	escape complex, origin unknown
VPARA	ventricular parasystole
APARA	atrial parasystole
VTRIG	ventricular trigeminy
ATRIG	atrial trigeminy
SVTRI	supraventricular trigeminy
TRIGU	trigeminal pattern (unknown origin, SV or Ventricular)
VQUAG	ventricular quadrigeminy
RECIP	reciprocal or re-entrant impulse

Rhythm statements related to (predominant) conduction and block

B2T1	(predominant) 2:1 block
B3T1	(predominant) 3:1 block
B4T1	(predominant) 4:1 block
B5T1	(predominant) 5:1 block
VARBL	variable block
EXIBL	exit block
ENTBL	entrance block
VABL	ventriculo-atrial block
BLOCK	unspecified delay or failure of impulse propagation
C2T1	(predominant) 2:1 conduction
C3T1	(predominant) 3:1 conduction
C4T1	(predominant) 4:1 conduction
C5T1	(predominant) 5:1 conduction
VARCO	variable conduction
SVR	slow ventricular response
IVR	irregular ventricular response

RVR	rapid ventricular response
WRV	wide rate variation
AAVCO	accelerated A V conduction
RETCO	retrograde conduction
ANTCO	anterograde conduction
ORTCO	orthograde conduction
ABBCO	aberrant conduction
CONCO	concealed conduction
AVREN	A V nodal re-entry
CONRE	concealed re-entry
RENTH	re-entry phenomenon
AECHO	return of impulse to its chamber of origin; the atrium
VECHO	return of impulse to its chamber of origin; the ventricle
FCOUP	fixed coupling interval
VCOUP	variable coupling interval

Rhythm statements related to pacemaker types and pacemaker function

PACE	normal functioning artificial pacemaker
PACEA	artificial pacemaker rhythm with 100% capture
PACEP	artificial pacemaker rhythm with partial capture
PACEF	artificial pacemaker rhythm with underlying atrial fib or flutter
PACED	demand pacemaker rhythm
PACEM	malfunctioning artificial pacemaker
EPAVS	electronic pacemaker, A V sequential, normal capture
EPVC	electronic pacemaker, ventricular capture
EPDM	electronic pacemaker, demand mode
EPFC	electronic pacemaker, failure to capture
EPFS	electronic pacemaker, failure to sense
EPARV	bipolar electronic pacemaker at the apex of the right ventricle
EPU	unipolar electronic pacemaker
EPURV	unipolar electronic pacemaker at the apex of the right ventricle
PAA	electronic atrial pacing

PAD	dual chamber electronic pacing
PAVA	electronic ventricular pacing with atrial sensing
PADEM	deman pacing, analysis based upon intrinsic complexes
OVPAC	occasional ventricular paced complexes
ONPAC	occasional non-paced complexes

Other rhythm related statements

ARATE	atrial rate
VRATE	ventricular rate
RATE	rate, not specified ventricular or atrial (but mostly ventricular)
RHY(T)	rhythm

Descriptive axis statements

LAD	left axis deviation of QRS in frontal plane ( $< -30$ )
RAD	right axis deviation of QRS in frontal plane ( $> +90$ )
AXL	leftward axis ( <i>i.e.</i> not severe enough to be called LAD)
AXR	rightward axis ( <i>i.e.</i> not severe enough to be called RAD)
AXIND	QRS axis indeterminate
AXSUP	axis shifted superiorly
AXPOS	axis shifted posteriorly
AXVER	axis vertical in frontal plane
AXHOR	horizontal axis in frontal plane
TRSLT	transition in horizontal leads shifted leftward
TRSRT	transition in horizontal leads shifted rightward
CCWRT	counterclockwise rotation
CWRT	clockwise rotation

ST-T descriptive statements

ISC	ischemic ST-T changes
INJ	ischemic ST-T changes compatible with subendocardial injury
EPI	ischemic ST-T changes compatible with subepicardial injury
NST	non-specific ST-T changes



STE	non-specific ST elevation
STD	non-specific ST depression
RST	reciprocal ST-T
TAB	T-wave abnormality
NT	non-specific T-wave changes
NDT	non-diagnostic T abnormalities
TNOR	normal T-wave variations
DIG	digitalis-effect
HTVOL	high T-voltages
QUIN	ST-T changes due to quinidine-effect
PERIC	ST-T changes compatible with pericarditis
STVAG	ST-elevation V1-V3 possibly due to enhanced vagal tone
LNGQT	long QT-interval
SHTQT	short QT-interval
HIGHT	high amplitude T-waves
LOWT	low amplitude T-waves
INVT	inverted T-waves
HPOCA	consider hypocalcemia
HPOK	consider hypokalemia
HPRCA	consider hypercalcemia
HPRK	consider hyperkalemia
STDJ	junctional ST depression
REPOL	ST-T changes compatible with early repolarization
ANEUR	ST-T changes compatible with ventricular rhythm
POSTO	post-operative changes
PULM	compatible with pulmonary embolism
ACET	related to pacemaker activity
NDOC	compatible with endocrine disease
METAB	possibly due to metabolic changes
IBP	compatible with hypertension
CONG	secondary to congenital heart disease
VALV	secondary to valvular heart disease

RESP	secondary to respiratory disease
JUV	juvenile T waves
CLIN	interpret with clinical data
MYOIN	suggests myocardial infarction (no location specified)
ISDIG	compatible with ischemia/digitalis effect
STNOR	normal variant
STPAC	review ST-T analysis for the effects of pacing
STPVC	post-extrasystolic T-wave changes

Atrial statements

LAW/LAE	left atrial overload/enlargement
RAO/RAE	right atrial overload/enlargement
BAO/BAE	bi-atrial overload/enlargement
IACD	intra-atrial conduction delay
HPVOL	high P-voltages
NSPEP	non-specific P wave abnormalities
ABPAX	abnormal P-axis
UNPAX	unusual P-axis

Statements related to pediatric ECG analysis

PED	pediatric interpretation
RVD	right ventricular dominance
ASD	changes compatible with atrial septal defect (ostium secundum)
ECD	compatible endocardial cushion defect (ASD ostium primum)
EBSTA	compatible with Ebstein's anomaly
TCA	compatible with tricuspid atresia
ACA	compatible with anomalous location of the coronary artery

Technical problems

ARMRE	suspect arm leads reversed
LMISP	lead misplacement
QCERR	poor data quality, interpretation maybe adversely affected

AHERR	acquisition/hardware error
MEASE	possibly measurement error
NOISE	noisy recording
WANDR	baseline wander
FAULT	faulty lead
ARTEF	artifacts
SIMUL	input is from simulator or test pattern
PINFO	inconsistent or erroneous patient demographic data
INCAN	incomplete or no analysis (by the program)
NODAT	missing or no data

#### **A.2.4.1.2 Probability**

The following list contains Defined Terms and associated meanings for Probability Attribute.

DE	definite
PR	probable
PS	possible
UN	unknown
CE	cannot exclude
SS	strongly suggestive
CO	consider
CW	consistent with

#### **A.2.4.1.3 Unary Conjunction**

The following list contains Defined Terms and associated meanings for Unary Conjunction Attribute.

NOT	boolean operator NOT
SQR	square root of
ABS	absolute value of
MAX	maximum value of
MIN	minimum value of
SER	serial changes of
DEC	decreased (in comparison to the previous recording)

INC	increased (in comparison to the previous recording)
UNC	unchanged/has not changed (in comparison to the previous recording)
CHG	changed/has changed (in comparison to the previous recording)
DIS	(now) disappeared (in comparison to the previous recording)
REP	(now) replaced ((statement) reported previously)
IMP	improved (in comparison to the previous recording)
WRS	worse (in comparison to the previous recording)

#### **A.2.4.1.4 Binary Conjunction**

The following list contains Defined Terms and associated meanings for Binary Conjunction Attribute.

AND	logical operator AND
ADD	arithmetic operator ADD (+)
SUB	arithmetic operator SUBTRACT (-)
MPY	arithmetic operator MULTIPLY (*)
DIV	arithmetic operator DIVIDE (/)
EXP	exponent
EQU	is equal to
ILT	is less than
IGT	is greater than
INE	is not equal to
IGE	is greater than or equal to
ILE	is less than or equal to
RES	results in
SEC	is secondary to
ASSOC	is associated with
EXC	exclude/rule out
WITH	with
ALT	alternating with

#### **A.2.4.1.5 Modifier Term**

The following list contains Defined Terms and associated meanings for Modifier Term At-

tribute.

Age: the age of an infarction or ischemic ST-T changes

OL	old
RE	recent
AC	acute
SU	subacute
AI	age indeterminate
AU	age undetermined
EV	evolving
XO	probably old
XA	probably acute (recent)
YO	possibly old
YA	possibly acute

Location: the location of ST-T and other abnormalities

AN	anterior
AS	anteroseptal
AL	anterolateral
IN	inferior
IL	inferolateral
PO	posterior
LA	lateral
HL	high lateral
IP	inferoposterior
BA	basal
AF	antero-inferior
SE	septal
PL	posterolateral
SN	subendocardial
SP	subepicardial
EX	extensive
WI	widespread

DI            diffuse

Severity: the severity of an abnormality

MA            major

MO            moderate

MI            minor

Time course: time course or the evolving nature of some abnormalit

SE            serial changes consistent with

CC            continuing changes of

OC            occasional

IM            intermittent

TE            temporary

EV            evolving

NE            new

MU            multiple

TR            transient

FR            frequent

UF            unifocal

MF            multifocal

Physiopathological nature: the physiopathological nature of S

LV            compatible with left ventricular strain

MD            compatible with myocardial ischemic damage

PE            compatible with pericarditis

EL            compatible with electrolyte abnormalities

Normality: the normality or abnormality of a finding

NO            within normal limits

NX            may be normal variant

BO            borderline

AB            abnormal

BN	borderline normal
BA	borderline abnormal

Rhythm modifiers/Anatomic locations

SI	sinus
AT	atrial
SV	supraventricular
ND	nodal
VE	ventricular

Miscellaneous

IC	incomplete
CP	complete
TY	typical
YT	atypical

**A.2.5 Proposed Addendum to Item C.7.3.1.1.1 of Annex C of Part 3 of the DICOM Standard**

The term “EG” (for Electrocardiogram) is to be added to the list of Defined Terms for the Modality Attribute (0008, 0060).

# Appendix B

## Part 4 Addendum

# Electrocardiogram Storage SOP Classes

### B.1 Addendum to Annex B of Part 4 of the DICOM Standard

#### B.1.1 Standard SOP Classes

Table B.1 lists the names of the proposed SOP Class UIDs to be added to Part 4 of the DICOM standard.

Table B.1: Electrocardiogram Standard SOP Classes

SOP Class Name	SOP Class UID
ECG Signal Storage	1.2.840.10008.5.1.4.1.1.482.1
ECG Interpretation Storage	1.2.840.10008.5.1.4.1.1.482.2



# Appendix C

## Part 6 Addendum

### Electrocardiogram Data Dictionary

Table C.1 lists the Attribute Names, together with their Attribute Tags, Value Representation and Value Multiplicity codes of the newly added Attributes. They are to be included in the Section 6 of Part 6 of the DICOM standard.

Table C.1: ECG Addendum to the Data Dictionary

Tag	Name	VR	VM
(0003, 0001)	Number of Signals	UL	1
(0003, 0002)	Rate	US	1
(0003, 0003)	PR	US	1
(0003, 0004)	QRSD	US	1
(0003, 0005)	QT	US	1
(0003, 0006)	QTc	US	1
(0003, 0007)	P-Axis	US	1
(0003, 0008)	QRS-Axis	US	1
(0003, 0009)	T-Axis	US	1
(0003, 000A)	AC Filter	US	1
(0003, 000B)	Bandpass Filter Sequence	SQ	1
(0003, 000C)	Low Cutoff Frequency	FL	1
(0003, 000D)	High Cutoff Frequency	FL	1
(0003, 000E)	Notch Filter Sequence	SQ	1
(0003, 000F)	Notch Filter Low Cutoff Frequency	FL	1
(0003, 0010)	Notch Filter High Cutoff Frequency	FL	1
(0003, 0011)	Limb Sensitivity	FL	1
(0003, 0012)	Chest Sensitivity	FL	1
(0003, 0013)	Base Sampling Frequency	FL	1
(0003, 0014)	Counter Frequency	FL	1
(0003, 0015)	Base Counter Value	US	1
(0003, 0016)	Base Date and Time	DT	1
(0003, 0017)	Group Sequence	SQ	1

Table C.1. ECG Addendum to the Data Dictionary (Continued)

Tag	Name	VR	VM
(0003, 0018)	ECG Group Number	US	1
(0003, 0019)	Group Description	LT	1
(0003, 001A)	Number of Signals	UL	1
(0003, 001B)	ECG Signal Sequence	SQ	1
(0003, 001C)	Calibration Pulse Shape	CS	1
(0003, 001D)	Calibration Peak-to-Peak Amplitude	FL	1
(0003, 001E)	Physical Unit	CS	1
(0003, 001F)	Trace Number	US	1
(0003, 0020)	Lead Identification	CS	1
(0003, 0021)	Signal Description	LT	1
(0003, 0022)	Samples per Frame	US	1
(0003, 0023)	Number of Samples	UL	1
(0003, 0024)	Skew	US	1
(0003, 0025)	ADC Resolution	FD	1
(0003, 0026)	ADC Zero	FD	1
(0003, 0027)	ADC Gain	FD	1
(0003, 0028)	Baseline	FD	1
(0003, 0029)	P-duration	FD	1
(0003, 002A)	PR-interval	FD	1
(0003, 002B)	QRS-duration	FD	1
(0003, 002C)	QT-interval	FD	1
(0003, 002D)	Q-duration	FD	1
(0003, 002E)	R-duration	FD	1
(0003, 002F)	S-duration	FD	1
(0003, 0030)	R'-duration	FD	1
(0003, 0031)	S'-duration	FD	1
(0003, 0032)	Q-amplitude	FD	1
(0003, 0033)	R-amplitude	FD	1
(0003, 0034)	S-amplitude	FD	1
(0003, 0035)	R'-amplitude	FD	1
(0003, 0036)	S'-amplitude	FD	1
(0003, 0037)	J-point-amplitude	FD	1
(0003, 0038)	P(+)-amplitude	FD	1
(0003, 0039)	P(-)-amplitude	FD	1
(0003, 003A)	T(+)-amplitude	FD	1
(0003, 003B)	T(-)-amplitude	FD	1
(0003, 003C)	ST-slope	FD	1
(0003, 003D)	QT Dispersion	FD	1
(0003, 003E)	P morphology	CS	1
(0003, 003F)	T morphology	CS	1
(0003, 0040)	Onset Iso-electric segment	FD	1
(0003, 0041)	End Iso-electric segment	FD	1
(0003, 0042)	Intrinsicoid deflection	FD	1
(0003, 0043)	Quality	CS	1
(0003, 0044)	Noise	CS	1
(0003, 0045)	ST20	FD	1
(0003, 0046)	ST60	FD	1
(0003, 0047)	ST80	FD	1
(0003, 0048)	ECG Samples	OB	1
(0003, 0049)	Annotator's Identifier	SH	1
(0003, 004A)	Annotation Codes	OB	1

Table C.1. ECG Addendum to the Data Dictionary (Continued)

<b>Tag</b>	<b>Name</b>	<b>VR</b>	<b>VM</b>
(0005, 0001)	Device Type	CS	1
(0005, 0002)	Printing Capability	CS	1
(0005, 0003)	Interpreting Capability	CS	1
(0005, 0004)	Storage Capability	CS	1
(0005, 0005)	Acquisition Capability	CS	1
(0005, 0006)	AC Main Frequency Environment	US	1

<b>Tag</b>	<b>Name</b>	<b>VR</b>	<b>VM</b>
(0007, 0015)	Start Time	US	1
(0007, 001B)	Preview Signal Sequence	SQ	1
(0007, 0023)	Number of Samples	UL	1
(0007, 0048)	Preview Samples	OB	1
(0007, 0049)	Annotator's Identifier	SH	1
(0007, 004A)	Annotation Codes	OB	1

<b>Tag</b>	<b>Name</b>	<b>VR</b>	<b>VM</b>
(0009, 0001)	Referenced ECG Series Sequence	SQ	1
(0009, 0002)	Referenced ECG Group Sequence	SQ	1
(0009, 0003)	Referenced Trace Sequence	SQ	1
(0009, 0004)	ECG Interpretation Term Sequence	SQ	1
(0009, 0005)	Interpretation Term ID	US	1
(0009, 0006)	Interpretation Term	CS	1
(0009, 0007)	Probability	CS	1
(0009, 0008)	Unary Conjunction	CS	1
(0009, 0009)	Binary Conjunction	CS	1
(0009, 000A)	Referenced Interpretation Term	US	1
(0009, 000B)	Modifier Sequence	SQ	1
(0009, 000C)	Modifier ID	US	1
(0009, 000D)	Referenced Term ID	US	1
(0009, 000E)	Modifier Term	CS	1

Table C.2 lists the Unique Identifiers to be added to Annex A of Part 6 of the DICOM Standard.

Table C.2: Addendum to the List of Unique Identifiers

UID Value	UID Name	UID Type	Part
1.2.840.10008.5.1.4.1.1.482.1	ECG Signal Storage	SOP Class	Part 4
1.2.840.10008.5.1.4.1.1.482.2	ECG Interpretation Storage	SOP Class	Part 4

# Bibliography

- [1] DICOM 3.0 Digital Image and Communication Standard, 1993.
- [2] *PageWriter 200/200i Cardiograph Analysis Program.*
- [3] Steven C. Horii, Fred W. Prior, Jr. W. Dean Bidgood, Charles Parisot, and Geert Claeys.  
Dicom: An introduction to the standard.
- [4] George B. Moody. ECG database application guide. Harvard-MIT Division of Health Sciences and Technology and Biomedical Engineering Center, July 1995.
- [5] George B. Moody. ECG database programmer's guide. Harvard-MIT Division of Health Sciences and Technology and Biomedical Engineering Center, July 1995.
- [6] George B. Moody. MIT-BIH arrhythmia database. Harvard-MIT Division of Health Sciences and Technology and Biomedical Engineering Center, July 1995.
- [7] Project Team 007 of CEN/TC 251 "Medical Informatics". A standard communications protocol for computerized electrocardiography. Final draft European prestandard voted on by the members of European Committee for Standardization.