

**Flexible Manufacturing Systems  
and the Housing Industry**

by

**Frank Robert Altobelli**

Master of Science, Civil Engineering  
Massachusetts Institute of Technology  
1991

Submitted to the Department of Civil and Environmental Engineering  
in Partial Fulfillment of the Requirements for the Degree of

**Doctor of Philosophy in Civil Engineering**

at the

Massachusetts Institute of Technology

June, 1997

© 1997 Massachusetts Institute of Technology  
All Rights Reserved

Signature of Author .....  
Department of Civil and Environmental Engineering  
January 28, 1997

Certified by .....  
PROFESSOR FRED MOAVENZADEH  
Thesis Supervisor

Accepted by .....  
Joseph M. Sussman  
Chairman, Departmental Committee on Graduate Studies

MASSACHUSETTS INSTITUTE  
OF TECHNOLOGY

JUN 24 1997 Eng

LIBRARIES

# **Flexible Manufacturing Systems and the Housing Industry**

by

**Frank Robert Altobelli**

Submitted to the Department of Civil and Environmental Engineering  
in Partial Fulfillment of the Requirements for the Degree of

**Doctor of Philosophy in Civil Engineering**

## **ABSTRACT**

This thesis describes how the U.S. homebuilding industry can improve the effectiveness of its production processes by adopting flexible manufacturing system technologies. Potential improvements go beyond a search for improved productivity, to encompass simultaneous gains in all production system attributes: cost, quality, flexibility, and time.

It is possible capture some of the benefits of automation without automating the entire process by automating the information processing functions. Automated information processing includes a digital linkage between design and manufacturing that is capable of automatically generating the information required for production. This thesis demonstrates how a computerized design system linked with an object oriented variant process planning system can achieve this. A predefined planning algorithm can be developed that does not decrease flexibility. The algorithm models the systemic knowledge contained in the "kit of parts" and the inherent process constraints of a specific off-site production system.

The background of thesis includes an analysis of the structure of the homebuilding industry and identifies the key products, components, and suppliers that contribute significant amounts of value to housing production and delivery. It describes the production processes and technologies that off-site suppliers currently use to make the key products and components. It investigates flexible manufacturing systems and determines the types of processes they are applicable to and the benefits and impacts that have resulted from their adoption. It identifies enabling and accompanying technologies. Finally, it demonstrates how flexible manufacturing systems can be applied to off-site production in housing.

Thesis Supervisor: Fred Moavenzadeh

Title: George Macomber Professor of Construction



**Thesis Committee:**

Fred Moavenzadeh, Chairman  
Professor  
Department of Civil and Environmental Engineering

Nicolas Patrikalakis  
Professor  
Department of Ocean Engineering

John Williams  
Professor  
Department of Civil and Environmental Engineering

## ACKNOWLEDGMENTS

While a Ph.D. is a solo effort, no one can accomplish it alone. Much of the credit for this work is due others. Therefore, I acknowledge the contributions made by others and sincerely thank them.

To the committee, thank you for your time, thoughts, and efforts in making this thesis better.

To the gang in the office (and the upstairs office): Pat, Danielle, Charlie, Cynthia, and Jessie, thank you for the untold number of times you helped me.

To the Army Research Office, thank you for providing funding through the Program for Advanced Construction Technologies. Without that funding, this thesis would not exist.

To all the people at Marvin Windows, especially Tom Schultz, Tom Amiot, Rick Maurer, Doug Johnson, Dan Myrick, Jeff Siverhus, and many others, who made my case study both enjoyable and immensely informative. There is no way to begin to describe how open, helpful, and kind these people were. They helped organize my visit, answered questions, and openly taught me about their business. My deepest gratitude is extended.

To the people who made my time at MIT fun:  
in the early years...

Mark J., John P., John E., Mike T., and others

the middle years...

Hank, Edmund, Brandt, Dan, Jon, Gwen, Marc, Michael, and the Newbury St. gang  
and in the final years...

Janine.

A special thanks to Fred for standing by me through this work, and for everything else, including: funding, guidance, confidence, and your unending patients.

And most of all, thank you Mom and Dad for all the years of encouragement and support.

# Table of Contents

<b>1. Introduction</b> .....	<b>7</b>
1.1 Purpose and Objectives .....	7
1.2 Background .....	8
1.3 Statement of Thesis .....	13
1.4 Organization of Thesis Argument.....	13
1.5 Outline of Thesis.....	14
<b>2. Analysis of the U.S. Homebuilding Industry</b> .....	<b>16</b>
2.1 Industry Size and Housing Demand Fluctuations .....	16
2.2 Industry Fragmentation .....	20
2.3 Housing Costs.....	23
2.4 Construction Materials Breakdown.....	26
2.5 Input-Output Analysis.....	27
2.6 Industry Flexibility .....	32
2.7 Summary.....	34
<b>3. Analysis of Supplying Industries</b> .....	<b>36</b>
3.1 Introduction.....	36
3.2 Prefabricated Wood Buildings / Mobile Homes .....	37
3.3 Millwork.....	45
3.4 Wood Kitchen Cabinets.....	49
3.5 Ready-Mixed Concrete .....	54
3.6 Conclusions .....	56
<b>4. Off-site Production Processes and Technologies</b> .....	<b>57</b>
4.1 Introduction.....	57
4.2 Prefabricated Wood Building Production .....	58
4.3 Structural Components Production .....	65
4.4 Millwork.....	72
4.5 Wood Kitchen Cabinets.....	76
4.6 Summary.....	77
<b>5. Computer Integrated Production Technologies</b> .....	<b>78</b>
5.1 Introduction.....	78
5.2 Computer Aided Manufacturing.....	90
5.3 Computer Aided Process Planning.....	94
5.4 Summary.....	102
<b>6. Flexible Manufacturing Systems for Off-site Production in Homebuilding</b> .....	<b>104</b>
6.1 Benefits of Automation in Construction .....	104
6.2 Past Approaches to Construction Automation.....	111
6.3 Applications of the Off-Site Approach in Housing .....	114
6.4 Technological and Non-Technical Hurdles .....	120

6.5 Conclusions .....	123
<b>7. A Case Study in Window Manufacturing .....</b>	<b>125</b>
7.1 Introduction.....	125
7.2 The Product.....	125
7.3 Production Control.....	127
7.4 Production Operations.....	139
7.5 Summary and Conclusions.....	156
<b>8. Process Planning for Off-site Production in Homebuilding.....</b>	<b>159</b>
8.1 Introduction - Planning for Multiple Production Resource Types .....	159
8.2 Functional Requirements of CIM Software for Off-Site Production in Housing .	161
8.3 Features of the Prototype Window Design and Process Planning System.....	165
8.4 The Hypothetical Window Manufacturing Factory.....	168
8.5 The Hypothetical Kit of Parts .....	176
8.6 A Prototype System for Flexible Computer Aided Process Planning in Window Manufacturing.....	180
8.7 Conclusions and Application to other Components .....	194
<b>9. Summary and Conclusions.....</b>	<b>196</b>
9.1 Summary of Content and Results .....	196
9.2 Contributions.....	199
9.3 Recommendations for Further Work.....	199
9.4 Final Comment.....	199
<b>Appendix A: Housing Varieties and Consumer Preferences .....</b>	<b>200</b>
<b>Appendix B: Code Excerpts .....</b>	<b>212</b>

# 1. Introduction

*Time* magazine's "Man of the Year" for 1982 has changed the world of manufacturing perhaps more than anyone else. He has unlocked the flexibility of automated machines. He has improved the flow of information from product designers to the plant floor by automating manufacturing process planning. And, he has allowed firms to alter the rules of competition to take advantage of these new capabilities. That "Man of the Year" was the computer. In fact, the availability of low cost computing power has been one of the driving forces in the development of flexible manufacturing systems.

Although numerous industries have benefited from the adoption of flexible production technologies, the innovations have yet to noticeably impact the construction industry. Homebuilding in particular has always been slow to adopt new process technologies. It has been said that houses are "...fitted together as of old by the cut-try-and-cut-again method. Similarly, the organization of the industry harks back to the guilds of the Middle Ages for its general form and character, this notwithstanding our greatly increased knowledge of raw materials, ...and the sweeping changes which have occurred in the technique and organization of most other industries during the past two hundred years." While this quotation is applicable today, it was written in 1934.<sup>1</sup>

## **1.1 Purpose and Objectives**

The overall purpose of this thesis is to develop an understanding of how the U.S. homebuilding industry can significantly improve the effectiveness of its production processes by adopting flexible manufacturing system technologies. As such, there are four key objectives of the thesis:

- To analyze the structure of the homebuilding industry and identify the key products, components, and suppliers that contribute significant amounts of value to housing production and delivery;
- To examine the production processes and technologies that are currently used to make the key products and components for housing;
- To investigate flexible manufacturing systems, to determine the types of processes they are applicable to and the benefits and impacts that have resulted from their adoption, and to identify enabling and accompanying technologies;

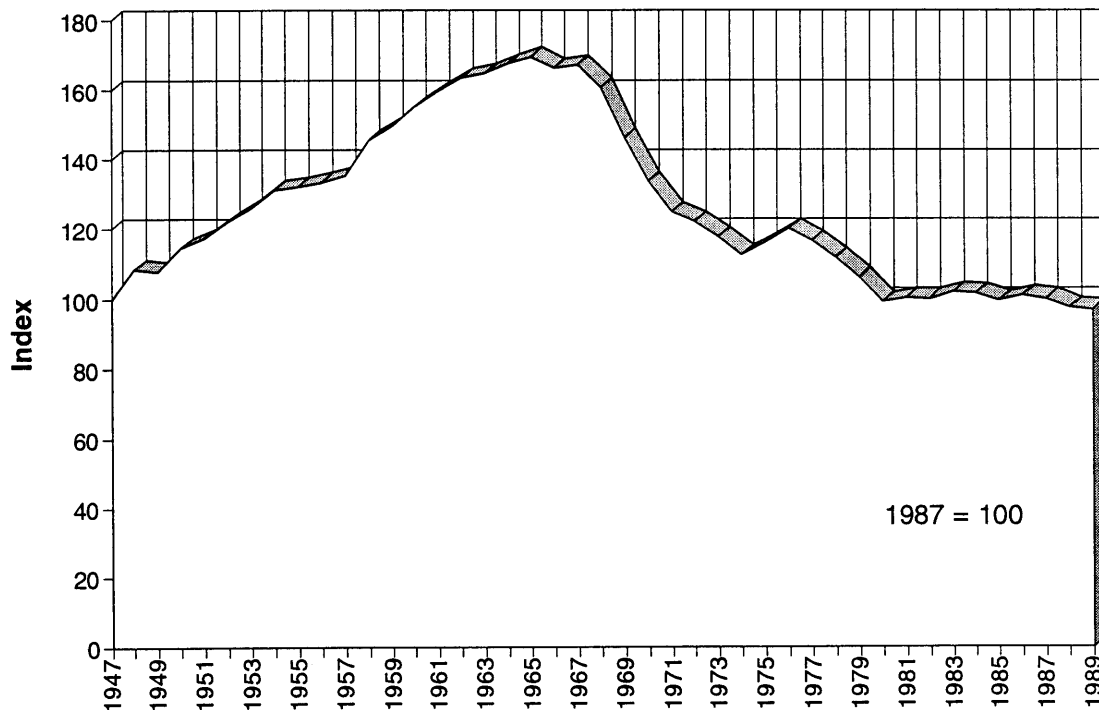
---

<sup>1</sup> Bemis, Albert Farwell, *The Evolving House, Volume II, The Economics of Shelter*, The Technology Press, Cambridge, 1934, pg 177.

- To demonstrate how flexible manufacturing systems can be applied in housing production.

## 1.2 Background

According to the Bureau of Labor Statistics, and as shown in Figure 1-1, productivity in construction has been falling since 1965.<sup>2</sup> Since the annual volume of the construction industry is roughly four hundred twenty-five billion dollars, the possible ramifications of this trend are alarming. In response to this threat to industry competitiveness, numerous attempts have been made to increase the level of automation in construction. The different approaches to construction automation research and development are described briefly below. The application of flexible manufacturing systems to housing, as described in this thesis, is consistent with the current best thinking in construction automation research.



**Figure 1-1: B.L.S. Construction Productivity Index**

This thesis focuses on the housing segment of construction for several reasons. First, residential construction comprises roughly one-half of total construction volume, so it is important financially. Second, housing is an extremely important determinant (among tangible products) of one's standard and quality of living, so it is important to consumers. Third, the housing product, while varied, is somewhat constrained compared to the construction industry in general, so the problem is tractable. Finally, it is intellectually

<sup>2</sup> U.S. Department of Commerce, Bureau of Labor Statistics

interesting since there are many different on-site and off-site homebuilding methods that are currently in use, yet no one knows which ones are the most effective.

Off-site industrialized housing techniques include modular home production, panelized housing, and several fairly highly automated housing production systems used by Japanese and Finnish companies. However, in the United States, industrialized housing production is dominated by the site-assembled method of construction. It is noteworthy that while industrialized approaches may appear to be very different from site-assembled construction, they are really quite similar. In all homebuilding methods, a home is assembled from a basic kit of parts. The differences in the production systems lie in how the parts are produced, where the parts are produced, and where they are assembled with other parts. For example, a modular house is very similar to a site-built house and is assembled from the same basic kit of parts (dimensional lumber, nails, drywall, paint, carpet, etc.). The methods differ in that more final assembly operations occur off-site in modular production. Moreover, the off-site production of pre-assembled components and materials such as wood trusses, wall panels, windows, pre-hung doors, and kitchen cabinets, comprise a significant contribution to value-added for *both* industrialized and site-built housing.

### **1.2.1 Construction Automation: An Evolution of Approaches**

In the past decade, automation and robotics have been focal points of research and development activities in construction and have been touted as technologies with the potential to revolutionize the industry. The results, in terms of actual impacts on the construction industry, have been disappointing. Except for a few systems such as partially automated grading<sup>3</sup> and the tele-operated robots developed for the Three Mile Island cleanup, very little has changed in the way construction operations are performed on-site.

Demsetz states that construction automation research has proceeded in two directions: task identification and hardware development.<sup>4</sup> The purpose of task identification is to identify tasks that are susceptible to automation. Good candidates are tasks that are highly repetitive, have a high labor content, and/or represent a large portion of construction cost. Hardware development efforts attempt to build prototype machines that demonstrate the feasibility of automating the identified tasks. The main focus for both task identification and hardware development has been *on-site* operations. This approach has met with limited success for three primary reasons.

---

<sup>3</sup> Tatum, C.B., and A.T. Funke, A.S.C.E. Journal of Construction Engineering and Management, Vol. 114, No. 1, March, 1988, pp. 19-35.

<sup>4</sup> Demsetz, Laura Ann, "Task Identification and Machine Design for Construction Automation," Massachusetts Institute of Technology Department of Civil Engineering, Ph.D. Dissertation, 1989.

One reason is that system designers have lacked a complete understanding of the functional requirements of the system. Everett identified this phenomenon. He made two observations. First, civil engineers, who generally lack the mechanical expertise to build machines, have typically performed the task identification studies. Second, electrical and mechanical engineers, who typically lack the construction expertise to define the functional requirements of tasks, have generally performed hardware development.<sup>5</sup> Thus, task identification researchers have levels of expectations that are higher than what is currently technically feasible. At the same time, the hardware developers have produced complex mechanical systems that are not suitable for a real world construction environment.

Several authors suggest that a multi-disciplinary approach to automation research should be taken.<sup>6</sup> Clearly, design teams *should* incorporate construction engineers and mechanical designers. In addition, it may be helpful to include or consult with computer programmers, experts in man-machine interfaces, workers, managers, and others. However, team-based design alone will not overcome all of the short-fallings of site-based automation.

The second primary reason for the limited success of on-site automation is that the construction products and techniques have evolved over thousands of years to optimize the ability of a human worker. The task of building a machine with human capabilities is extremely difficult, and is beyond the reach of today's technology. Therefore, robots and automated systems that attempt to simply replace the construction worker inevitably perform unsatisfactorily and are too costly. A better approach is to simultaneously reconfigure both the product and the process for ease of assembly utilizing automated production systems. This lesson was first learned in the manufacturing field. Design for manufacturability (D.F.M.) and design for assembly (D.F.A.) have resulted in redesigned and simpler products and processes and have enabled engineers to develop much less expensive automated systems. In other words, simply replacing workers with automatons has never produced success.

Several researchers have identified this need to restructure construction tasks to maximize the benefits of automation. For example, Demsetz stated “Even greater productivity

---

<sup>5</sup> Everett, John G., “Construction Automation: Basic Task Selection and Development of the CRANIUM,” Massachusetts Institute of Technology Department of Civil Engineering, Ph.D. Dissertation, 1991.

<sup>6</sup> Demsetz, Laura Ann, “Task Identification and Machine Design for Construction Automation,” Massachusetts Institute of Technology Department of Civil Engineering, Ph.D. Dissertation, 1989.



improvements can be realized if simultaneous changes in construction methods, materials, and design are made...,” rather than to automate tasks in isolation.<sup>7</sup>

The third reason pertains to the nature of construction operations. There are fundamental differences in the production processes involved in construction and manufacturing. In construction, the batch size is one (unique products). However, manufacturing batch sizes are on the order of tens, hundreds, or thousands. Construction operations are site specific, while in a factory environment, operations for identical products are identical. The construction environment is more complex than a factory environment and is constantly changing. Since the product is large and fixed, the machine must go to the work, rather than the work going to the machine, as in a factory. Weather also impacts construction operations.<sup>8</sup> Mobility, space, and access are limited in construction, while a factory is designed to provide adequate space. Such a complex, dynamic environment demands that site-based automated systems have vision and sensing systems that are at the forefront of today's technological capabilities. These inherent differences between construction and manufacturing cause on-site automated systems to be far too complex and expensive, and to provide less than stellar performances.

Demsetz suggests that there are two approaches to overcoming the complexities of the jobsite: move production to a factory or factory-like environment; or, focus on semi-automated systems, the “smart tools” approach.<sup>9</sup> However, the two approaches are not interchangeable. Certain tasks are well suited to off-site production, while others must be performed on-site. Thus, each approach is optimal for different processes and tasks. In fact, when used together they complement each other. Off-site produced components and subassemblies are more competitive when efficient tools are available for installation, and “smart tools” are even “smarter” when they are installing highly complete, high value-added components. So while smart tools continue to provide promise for on-site installation, this thesis will focus on the adaptation of flexible manufacturing technologies to off-site processes in homebuilding.

Off-site automated production combined with on-site installation neutralizes the problems with the inherent nature of construction by moving much of the work off-site to a controlled environment. It also allows design for assembly to be rationally applied to a component or subsystem slated for off-site production. In addition, rather than

---

<sup>7</sup> Demsetz, Laura Ann, “Task Identification and Machine Design for Construction Automation,” Massachusetts Institute of Technology Department of Civil Engineering, Ph.D. Dissertation, 1989.

<sup>8</sup>Vallings, H.G., *Mechanization in Building*, Applied Science Publishers, London, 1975

<sup>9</sup> Demsetz, Laura Ann, “Task Identification and Machine Design for Construction Automation,” Massachusetts Institute of Technology Department of Civil Engineering, Ph.D. Dissertation, 1989.

“reinventing the wheel,” construction automation researchers can take advantage of the existing body of research on factory automation. In other words, instead of adapting current automation technologies to on-site construction, it is better and more efficient to move some construction operations to the manufacturing realm. Automation technologies are already well developed and “fit” well with the environmental conditions and organizational structures found in manufacturing. Since it can be shown that the percentage of value-added off-site is increasing, the application of advanced off-site production systems will serve to complement a prevailing phenomenon.

### **1.2.2 Effectiveness of Production Systems**

As used in this thesis, a flexible manufacturing system, or FMS, refers to a production system that exhibits flexibility. By this definition, a builder or a subcontracting firm could each be described as a “flexible manufacturing system.” Any notion of constraining the acronym FMS to its usual connotation, a computer controlled machining center, must be forgotten. In this thesis, the term implies a much broader, multi-dimensional notion of variety and flexibility and is non-specific in terms of technological implementation. Under this definition, the homebuilding industry itself is a large FMS, producing a variety of housing types and sizes with varying annual and seasonal volumes. This thesis attempts to characterize the flexibility required for production in housing and describes how each segment of the housing industry satisfies these requirements.

In this new paradigm for automated building construction, production operations are classified as on-site operations and off-site operations. Automation of off-site operations can borrow substantially from the proven manufacturing and assembly technologies used in other industries. Thus, the housing industry can leverage the vast body of knowledge that has resulted from past and current research expenditures of the automotive, aerospace, and other manufacturing industries — as well as the knowledge that will result from future expenditures. Automation of on-site operations will focus on the development of “smart-tools” and other automated or partially automated equipment to aid the installation of the off-site produced components and subassemblies.

Manufacturing industries have realized numerous benefits from mechanization and automation. Productivity increases have resulted in reduced costs and labor requirements while increasing the production rate. Workers are spared boring, repetitive tasks and heavy manual tasks, thus worker safety and morale have improved. Quality has improved drastically over manual operations, and some tasks that were impossible to accomplish by hand are now possible. In addition, firms can maintain production in spite of scarce or unavailable labor.

The functional requirements for a production system originate with consumer preferences, and they are narrowed by the firm's competitive strategy. In other words, a firm chooses to compete in a given segment or segments of the market. The production strategy is based on the chosen market and enumerates the production requirements in terms of measures of cost, quality, flexibility, and time (hereafter referred to as the manufacturing attributes). For example, a firm focusing on the low cost segment of the market will have

much different requirements for its production system than a firm competing on quality. However, both will look to the market for consumer preferences within each niche.

### **1.3 Statement of Thesis**

The fundamental tenet in this thesis is that the homebuilding industry can take advantage of flexible manufacturing system technologies to improve off-site production. Potential improvements go beyond a search for improved productivity, to encompass simultaneous gains in all production system attributes: cost, quality, flexibility, and time.

Flexible manufacturing processes differ from rigid production processes in that they are able to take advantage of instance specific information to adjust their process parameters. Thus, they have a material processing component and an information processing component. It is possible to improve many of the processes used in homebuilding and gain many of the advantages of automation without automating the entire process. This can be achieved by automating the information processing components of the processes and by automating the information flows.

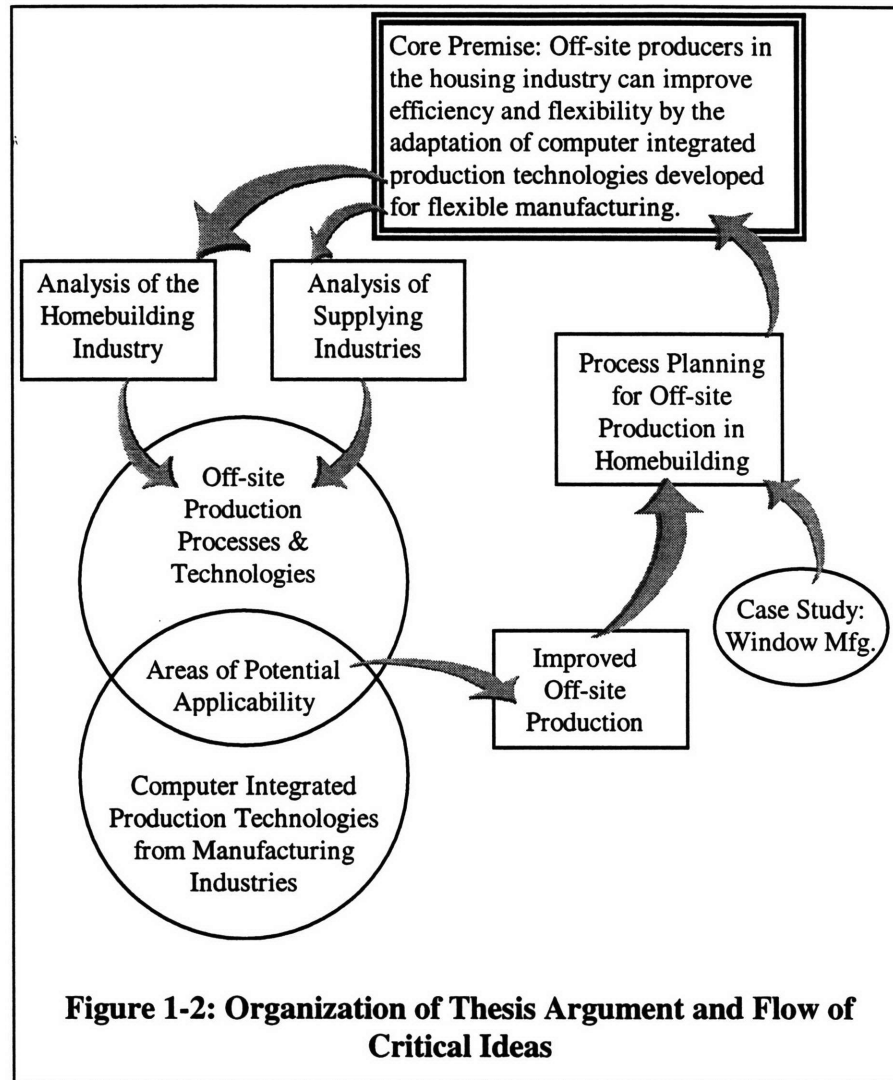
Automated information processing requires a digital linkage between design and manufacturing that is capable of automatically generating the information required for production. This thesis demonstrates how an object oriented computer aided design system linked with a parametric process planning system can achieve this. A predefined planning algorithm can be developed that does not decrease flexibility. The algorithm models the systemic knowledge contained in homebuilding's "kit of parts" and the process capabilities and constraints for a specific off-site production system.

### **1.4 Organization of Thesis Argument**

This thesis will build an argument that flexible manufacturing system technologies are applicable to certain off-site processes in homebuilding. It shows that it is beneficial to automate the information processing tasks of production whether or not the corresponding material processing operations can be automated.

As shown in Figure 1-2, the argument follows a logical flow of ideas. The core premise of the thesis is that the housing industry can improve cost, quality and flexibility while decreasing production time by adapting these technologies to off-site production in homebuilding. The proof of this supposition begins with an analysis of the homebuilding industry and an analysis of key supplying industries. Significant sources of cost and value are identified. This leads to a close look at the technologies utilized by key off-site processes. The areas of potential applicability can be identified by comparing common off-site production technologies with the computer integrated production technologies of flexible manufacturing. This leads to a vision of improved off-site production. The argument concludes with a description of a prototype design and production planning system. The system improves off-site production by automating the information

processing components of the processes. The prototype system is based on a detailed study of an off-site window production factory and embodies the vision set forth.



### 1.5 Outline of Thesis

The thesis contains nine chapters:

- 1: Introduction
- 2: Analysis of the U.S. Homebuilding Industry
- 3: Analysis of Supplying Industries
- 4: Off-site Production Processes and Technologies
- 5: Computer Integrated Production Technologies
- 6: Flexible Manufacturing Systems for Off-site Production in Homebuilding
- 7: A Case Study in Window Manufacturing
- 8: Process Planning for Off-Site Production in Homebuilding
- 9: Summary and Conclusions

Appendix A: Housing Varieties and Consumer Preferences  
Appendix B: Prototype System Implementation

Chapter Two presents an overview of the economics of homebuilding. The analysis identifies the areas in housing production that contribute a great deal of value added.

Chapter Three extends the analysis presented in Chapter Two to some of the key industries that supply homebuilders.

Chapter Four describes the production technologies and machines used in off-site production of key components.

Chapter Five presents an analysis of the state-of-the-art technologies of flexible manufacturing systems and computer integrated manufacturing.

Chapter Six presents a vision of the adaptation of flexible production technologies to off-site production for housing. Applicable processes are identified and potential benefits are described.

Chapter Seven presents a detailed case study of a major U.S. window producer. The study describes operations, production technologies, and information flows.

Chapter Eight describes the design and development of a prototype object oriented process planning system for window manufacturing.

Chapter Nine presents a summary of major findings and conclusions.

Appendices: Appendix A provides a sampling of the vast range and variety produced by the homebuilding industry, while Appendix B presents the implemented software for the prototype system described in Chapter Eight.

## 2. Analysis of the U.S. Homebuilding Industry

The purpose of this Chapter is to describe the economic structure of the homebuilding industry in the United States. The primary emphasis is on the construction phase, including both the off-site production of components and materials and their on-site assembly and installation. Specifically, the objective is to track where money is being spent in housing production, so that production improvements can be focused on high-impact processes. The following analysis is based primarily on three sources of data: reports from the National Association of Home Builders, industry trade publications, and input-output account data compiled by the U.S. Department of Commerce.

Housing is unique in that it requires more production flexibility than virtually any other manufactured product to satisfy the vast range of materials, styles, and variations demanded by the market. Appendix A: Housing Varieties and Consumer Preferences includes a survey of the range of product styles and components that are available, including a description of some regional product differences.

### 2.1 Industry Size and Housing Demand Fluctuations

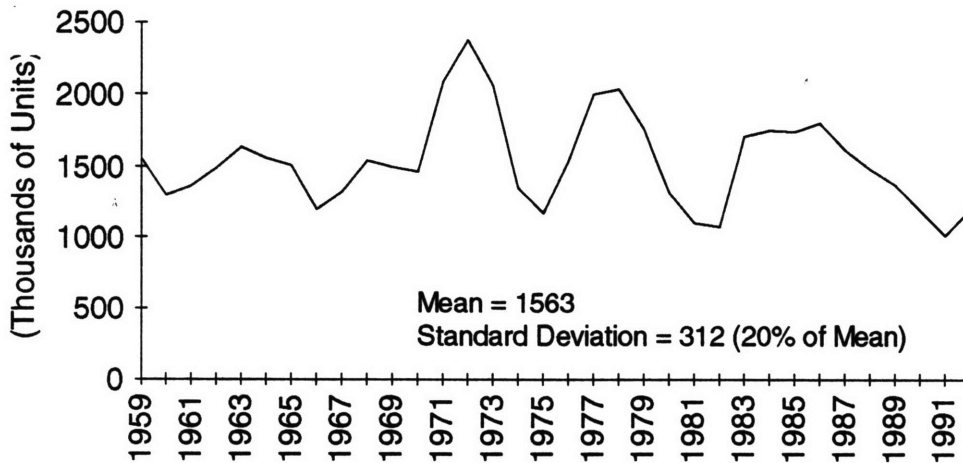
The homebuilding industry is extremely large by any measure. In fact, the *new residential construction* industry segment is comparable in size to the U.S. automobile industry, with the home remodeling industry adding significantly (about fifty percent more) to total demand. However, as described in this Section, the demand for housing and the annual production volume of the industry fluctuates greatly.

#### 2.1.1 Housing Starts

New single family homes are the most important output of the U.S. housing industry. In 1934, Bemis stated "...the single family dwelling has long been the social ideal. It has been and still is the predominating type in this country."<sup>1</sup> During the past thirty-five years, builders in the United States have produced an average of over one million single family homes annually. In addition, they have built roughly one-half million multi-family homes each year. Single family homes are defined as one-unit structures built on detached lots. Multi-family homes are homes built in two or more unit structures and may or may not have separately deeded land. Figure 2-1 shows the combined annual production (in number of units produced) between 1959 and 1992, while Figure 2-4 and Figure 2-5, respectively, show the single and multi-unit components of demand for the same time period.

---

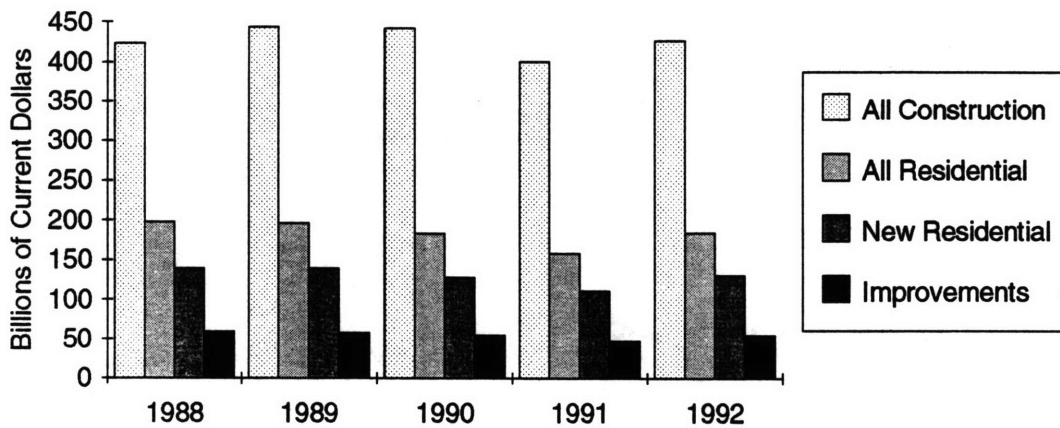
<sup>1</sup> Bemis, Albert Farwell, *The Evolving House, Volume II, The Economics of Shelter*, The Technology Press, Cambridge, 1934, pg. 43.



**Figure 2-1: Total Housing Unit Starts**

### 2.1.2 Residential Construction Dollar Volume

The volume of residential construction activity in the United States is almost two hundred billion dollars per year. New construction constitutes about seventy percent of that amount and remodeling and home improvements constitute thirty percent. Figure 2-2 shows the values of the types of residential construction put in place relative to each other and to the entire construction industry for the past five years. The graph shows that residential construction is indeed a huge industry, comprising roughly half of total construction expenditures.



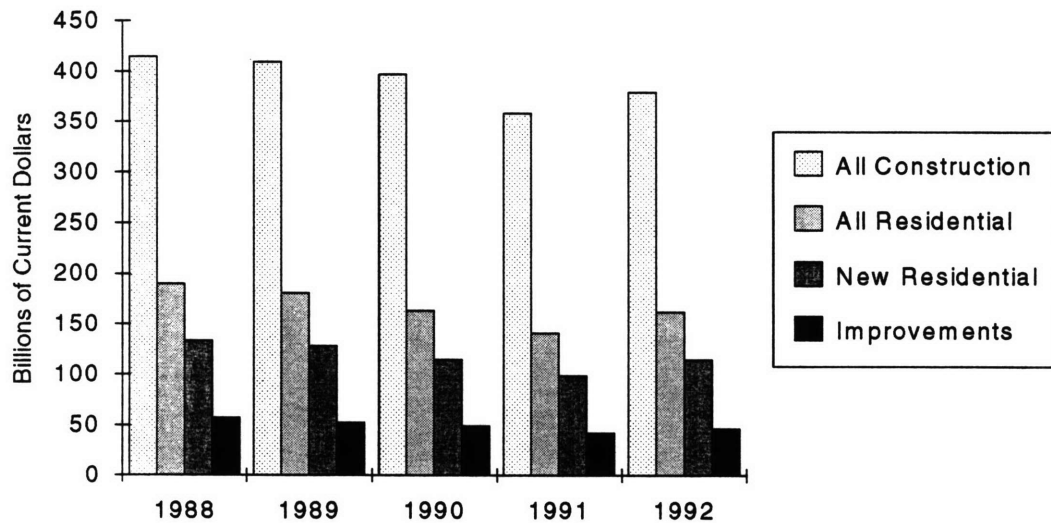
**Figure 2-2: Residential Construction Volume (Current Dollars)**

For comparison, in 1990, the value of motor vehicles sold in the U.S. was one hundred forty billion dollars, including automobiles and light trucks.<sup>2</sup> Thus, new residential

<sup>2</sup>U.S. Department of Commerce, *U.S. Industrial Outlook 1994*, Chapter 35, 1994.

construction volume is roughly equal to the volume of what people commonly think of as the largest industry in the U.S., motor vehicles. Because of the large dollar volume of the homebuilding industry, even a small percentage reduction in cost will correspond to a relatively large saving in dollars.

Figure 2-3 shows the volume of residential construction activity in constant 1987 dollars. Thus, it shows the relative health of the market during the five years shown and will be referred to in the discussion of construction costs and profitability in the sections below. As is evident from the graph, the market fell from 1988 to 1991, but rebounded in 1992. At the low point in 1991, the industry produced only 1.01 million new housing units (total of single and multi family units). This represented a thirty-five percent lower volume than the thirty-three year mean plotted in Figure 2-1. Although 1992 was a recovery year, the reported nineteen percent improvement over 1991 was poor compared to the initial recovery year of other recent recoveries. For example, the value of new home contracts jumped sixty-five percent in 1983 and forty-four percent in 1976.<sup>3</sup> Section 2.1.3 describes this highly variable nature of housing demand.



**Figure 2-3: Residential Construction Volume (Constant Dollars)**

### 2.1.3 Variability in Housing Production

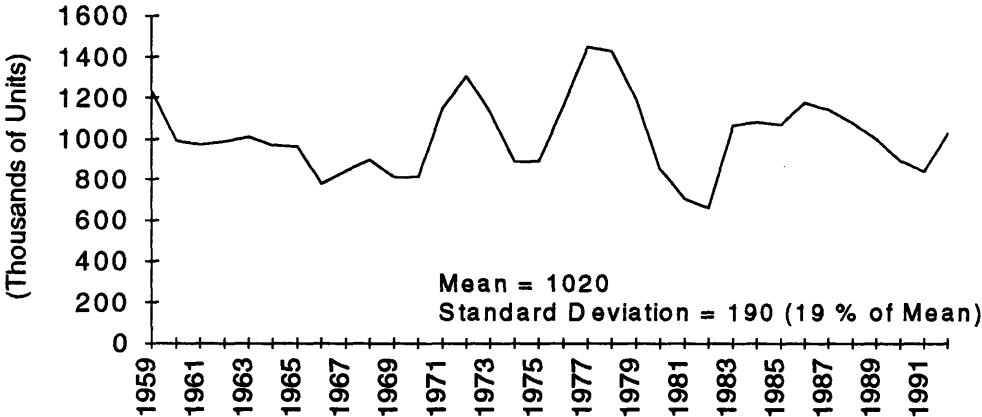
The number of both single and multi-family housing units produced annually varies significantly, as shown in Figure 2-1, Figure 2-4, and Figure 2-5. The standard deviation of the total number of units produced is equal to 312 thousand units, or twenty percent of the mean (Figure 2-1). This variation is roughly the same for single unit structures, at nineteen percent of the mean (Figure 2-4). However, as shown in Figure 2-5, the

---

<sup>3</sup> "Building & Forest Products," *Standard & Poor's Industry Surveys*, Vol. 161, No. 31, Sec. 1, August 5, 1993.



variation in multi-unit structures is doubled, at forty percent of the mean. Note also that regional and local variations in production may be greater than these aggregate numbers. Variation in housing demand is significant, since it determines the level of volume flexibility that the industry, its suppliers, and the distribution system must have. High levels of volume flexibility may be incompatible with production systems having a high ratio of fixed to variable costs.

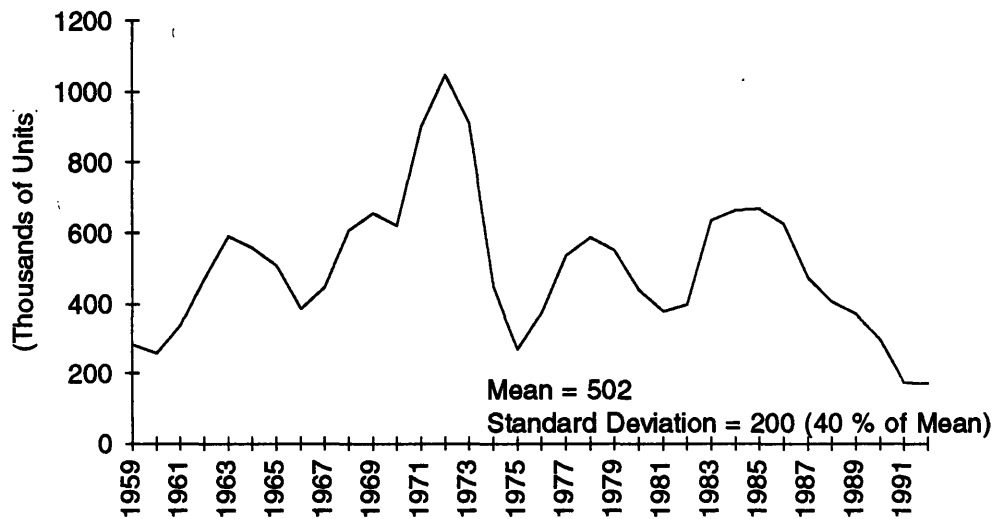


**Figure 2-4: Private Single-Unit Housing Starts**

There are many reasons for the variation in housing demand and production. One reason is the variability in mortgage interest rates and lending practices. Lange stated that there is a negative 1.5 correlation coefficient between short term mortgage interest rates and housing starts.<sup>4</sup> This implies that a ten percent increase in the short term mortgage interest rate would cause a fifteen percent drop in housing starts. In addition, lending practices can also affect housing starts. Lange also stated that there is a correlation coefficient of negative 2.3 between lower down payment requirements and housing starts. This means that a ten percent decrease in the required down payment would increase housing starts by twenty-three percent. These effects occur simply because many more people are able to afford homes, increasing the *effective* demand for homes almost instantaneously. However, the long term level of mortgage interest rates is uncorrelated with the overall level of housing production. This demonstrates that housing is a necessity and that while consumers can defer consumption of new housing, they cannot defer it indefinitely.

---

<sup>4</sup>Lange, Julian E. and Daniel Quinn Mills. *The Construction Industry*, Lexington Books, Lexington, MA, 1979.



**Figure 2-5: Private Multi-Unit Housing Starts**

Whatever the reasons for the fluctuations in demand, the result is industry over-capacity that eliminates profits in periods of slow demand, and industry under-capacity that drives up costs in periods of high demand. This industry characteristic has persisted for decades. For example, in 1922, Secretary of Commerce Herbert Hoover estimated that the production capacity for leading building materials was thirty percent higher than would be required under level demand, but during boom times the demand over-taxed facilities.<sup>5</sup>

Remodeling and home improvements, as described above, constitutes a significantly large segment of the residential construction market. In addition, the market tends to be counter-cyclical with the fluctuations in new residential construction. Thus, by working in both the new construction and remodeling segments, some firms have been able to partially level the demand fluctuations.<sup>6</sup>

## 2.2 Industry Fragmentation

The homebuilding industry is extremely fragmented. Seventy-five percent of builders produce fewer than twenty-five units per year, and only nine percent of firms build over one hundred units annually.<sup>7</sup> Likewise, the largest homebuilder in the U.S., the Centex

---

<sup>5</sup>Bemis, Albert Farwell, *The Evolving House, Volume II, The Economics of Shelter*, The Technology Press, Cambridge, 1934.

<sup>6</sup> Rubinstein, Nathan, "Residential Alterations and Repairs," *Construction Review*, September-October, 1984, pp. 4-18.

<sup>7</sup> National Association of Home Builders, *Strategic Issues for Home Builders, 1990-1992 and Beyond*, 1990.

Centex Corporation, sold 9634 units, capturing less than one percent share of the market. For comparison, the largest producer of motor vehicles in the U.S., General Motors, had a 34.2 percent share of the market in 1992.<sup>8</sup>

A common measure of industry consolidation and market power is the  $k$ -firm concentration ratio,  $C_k$ , which represents the combined market share of the top  $k$  firms in terms of sales volume. Prior to 1982, the simple four-firm concentration ratio,  $C_4$ , was part of the U.S. Justice Department's merger guidelines.<sup>9</sup> Since then, a slightly more sophisticated (and more complicated) method has been in use. Nonetheless,  $C_4$  is a common and useful way to characterize industry consolidation.

In the motor vehicle industry, for example,  $C_4$  was 80.2 percent in 1992.<sup>10</sup> In the same year, the National Association of Homebuilders estimated  $C_{100}$  for the housing industry at roughly fifteen percent.<sup>11</sup> A recent report of housing's largest four hundred builders in *Professional Builder and Remodeler*<sup>12</sup> included a measure of  $C_{400}$  for the years 1980 through 1993. As shown in Figure 2-6,  $C_{400}$  has averaged roughly thirty-two percent. What is clear from these statistics is that residential construction is an extremely fragmented industry. Individual builders have virtually no market power on a national basis. In addition, the degree of fragmentation seems to be stable over time, with no trends toward increasing or decreasing fragmentation.

---

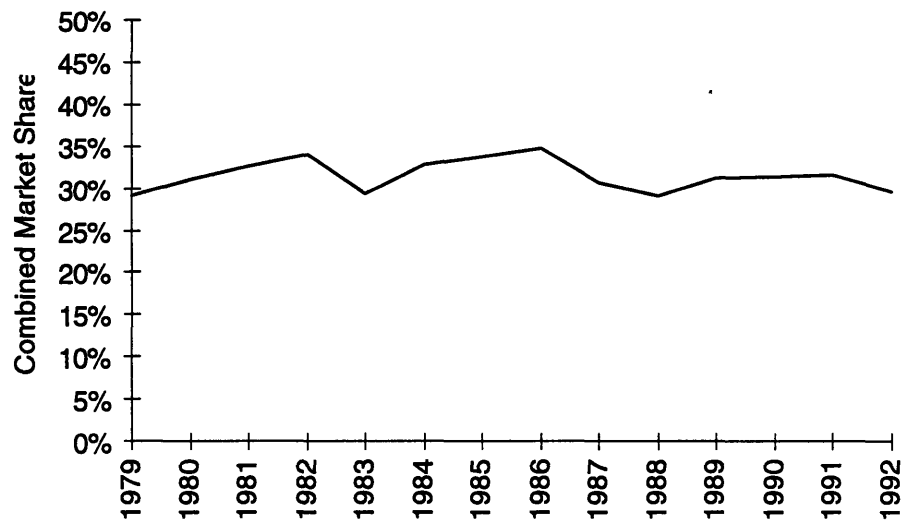
<sup>8</sup> U.S. Department of Commerce, *U.S. Industrial Outlook 1994*, Chapter 35, 1994.

<sup>9</sup> Sleuwaegen, Leo E., Raymond R. De Bondt, and Wim V. Dehandschutter, "The Herfindahl Index and Concentration Ratios Revisited," *The Antitrust Bulletin*, Fall, 1989, pp. 625-640.

<sup>10</sup> U.S. Department of Commerce, *U.S. Industrial Outlook 1994*, Chapter 35, 1994.

<sup>11</sup> *The Future of Home Building, 1992-1994 and Beyond*, National Association of Homebuilders, Washington, D.C., 1992.

<sup>12</sup> "PB&R's 26 Annual Report," *Professional Builder & Remodeler*, July, 1993.



**Figure 2-6: Combined Market Share, Top 400 Firms**

One might argue that housing is a regional business since there is no national distribution system for housing. Therefore, perhaps regional markets are consolidated. It is true that regional builders have more of a market *presence* than when measured nationally. However, fragmentation is still very severe in regional markets and builders still lack market *power*, as evidenced by the relatively low profit margins described in Section 2.3.1 below. For example, in 1993 in the Washington, D. C. metropolitan area, the top firm claimed only 7.1 percent of the number of subdivision sales in the region.<sup>13</sup> A subdivision sale is defined as the sale of a home in a project of thirty or more units. In that region, 325 different builders built subdivisions of that size. The top twenty of them combined for just over half of the total subdivision sales. Note that this does not correspond to a C<sub>20</sub> measure, since consolidation ratios reflect dollar volume and would also include projects of any size. When projects of all sizes are considered, these market shares are reduced.

Another interesting phenomenon related to the fragmentation of the industry and the fluctuation in demand is that there are significant swings in the number of firms actively participating in the industry. According to a National Association of Homebuilders report, the number of firms with at least one employee on the payroll was 129,245 in 1977. It fell to 93,632 in the recession year of 1982 (down twenty-eight percent in five years), and climbed back to 119,287 by 1987 (up twenty-seven percent in five years).<sup>14</sup> The ability of firms to easily enter and exit the industry in response to the variable

---

<sup>13</sup> Regardie, Renay, and Stephen Fuller, *Metropolitan Washington 1993 Real Estate Review*, 1994.

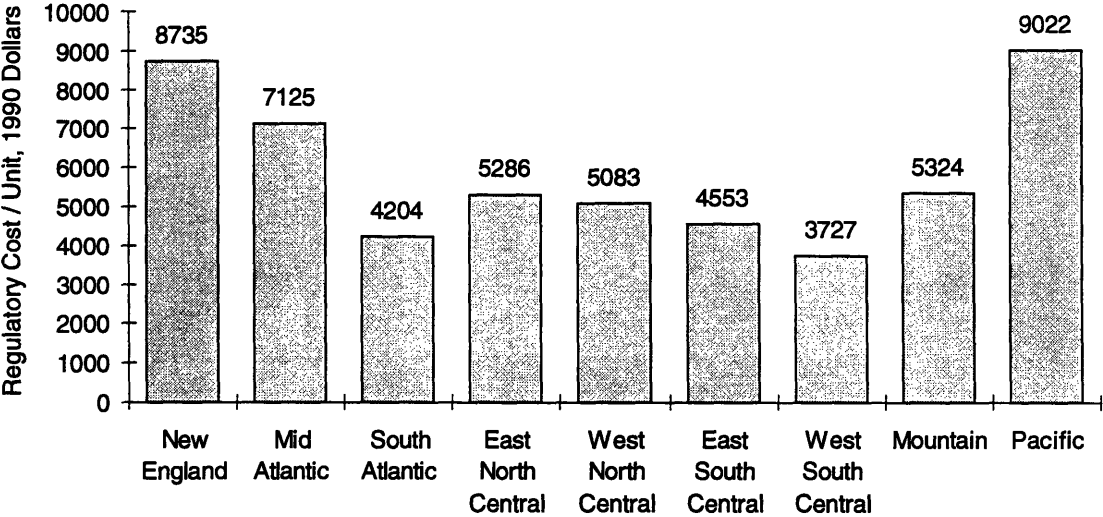
<sup>14</sup> *The Future of Home Building, 1992-1994 and Beyond*, National Association of Homebuilders, Washington, D.C., 1992.

demand for new housing is due to the fact that entry and exit barriers are low. Fragmentation contributes to low barriers, as does the low level of capital investment required for production and the slow rate of technological change in the industry.

### 2.3 Housing Costs

Housing costs encompass much more than simply construction costs. They include numerous items that are beyond the control of the builder since they are external to the actual construction phase. These include land cost, regulatory costs, short and long term financing costs, and others.

Moreover, as shown in Figure 2-7, regulatory costs and land cost vary significantly by region.<sup>15</sup> For example, regulatory costs for a new home with two thousand square feet of living space totaled 26,484 dollars in San Francisco. The same home in Kansas City had regulatory costs of only 1,300 dollars.<sup>16</sup> This discrepancy is due to the different propensities of local governments to support growth.



**Figure 2-7: Regulatory Costs by Region**

Before focusing on a detailed breakdown of construction costs, it is useful to examine the total cost breakdown for housing. Table 2-1, which is based on a July 1993 report in

<sup>15</sup> Wells, Karen, "What 1991 Buyers Want in Housing," *Professional Builder & Remodeler*, December 1, 1990.

<sup>16</sup> "Building & Forest Products," *Standard & Poor's Industry Surveys*, Vol. 161, No. 43, Sec. 1, October 28, 1993.

Professional Builder and Remodeler, presents a breakdown of builders' costs for a typical house.<sup>17</sup> Note two things when considering this data. First, the survey represents the four hundred largest builders in the U.S. in terms of dollar volume produced. Second, the report refers to the 1992 market year, which was the first year of a rebounding market (see Figure 2-3).

	South	East	North	West	Average
Materials	35.7%	29.7%	35.1%	30.4%	32.7%
Labor	18.0%	23.2%	18.9%	16.0%	19.0%
Raw Land	12.0%	10.7%	10.2%	13.3%	11.6%
Land Improvements	8.6%	11.9%	10.4%	13.4%	11.1%
Profit	8.3%	7.5%	7.9%	9.4%	8.3%
Overhead/Misc.	6.9%	7.7%	8.3%	5.5%	7.1%
Marketing & Sales	5.2%	4.1%	4.2%	4.3%	4.5%
Construction Financing	3.7%	3.8%	3.3%	5.9%	4.2%
Advertising	1.6%	1.4%	1.7%	1.8%	1.6%

**Table 2-1: Total Cost Breakdown for Housing**

Table 2-1 shows that construction cost, defined as the sum of labor and material costs, comprises only about fifty-two percent of the overall cost of housing. Therefore, if the adoption of flexible manufacturing system technology causes an x percent decrease in production cost, it would only reduce total housing cost by roughly x/2 percent. Also, overhead and profit represent only about fifteen percent of total housing cost, demonstrating a lack of capital investment even by large builders. Other significant costs include land at about twenty-three percent, sales costs at roughly six percent, and financing costs, at four percent. In addition to the direct effects on production costs, changes in production technologies would also be likely to reduce financing costs, if they shortened the duration of construction. However, it is unlikely that changes in production technologies would affect any of the other contributors to housing cost.

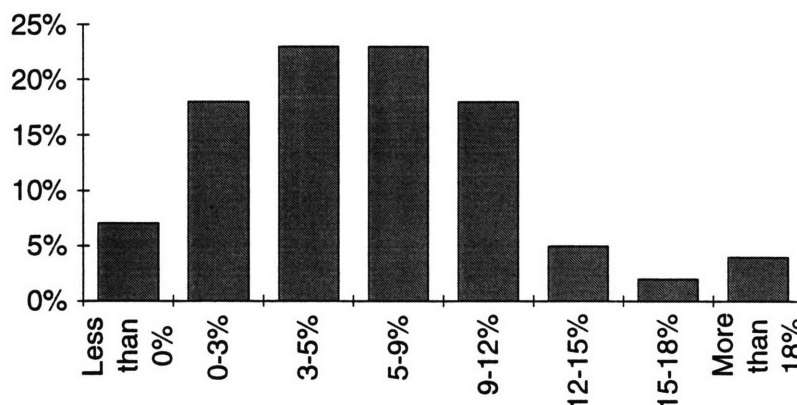
### 2.3.1 Profit Percentages

Profit percentages were verified with three additional sources of data. As shown in Table 2-1, the top four hundred builders surveyed by *Professional Builder & Remodeler* earned profits of between 7.5 percent and 9.4 percent of revenues in 1992, averaged for each operating region of the country. A report in *Builder Magazine*, the National Association of Homebuilders' monthly publication, charted the distribution of profit percentages of the one hundred largest residential contractors in 1989. As shown in Figure 2-8, profit percentages ranged from negative to above eighteen percent. However, eighty-two percent of the contractors surveyed earned profits between zero and twelve percent of revenue. This data suggests slightly lower profits than the *Professional Builder & Remodeler* data. The final source was an industry expert. He stated that the data was

---

<sup>17</sup> "PB&R's 26th Annual Report," *Professional Builder & Remodeler*, July, 1993.

fairly accurate, but suggested that in a relatively slow market, a firm would be happy with a profit of roughly five percent of revenue.



**Figure 2-8: Pretax Net Margins of Top 100 Residential Contractors in 1989**

What is significant about these profit percentages is that they are fairly low. This is not a surprise considering builders' lack of market power. Producers of HUD Code (mobile) homes, whose industry is less fragmented, reportedly also earned only about five percent profit in the years between 1984 and 1991.<sup>18</sup> In comparison, building materials manufacturers, which tend to invest more money in capital goods for production, reportedly earned roughly fifteen percent profit during the same period.

### 2.3.2 Variations in Costs by Builder Size

As shown in Table 2-2, the cost structure of large builders differs from that of small builders. For example, the percentage of cost attributable to overhead more than triples when a builder goes from producing under ten homes per year to an annual volume of over one hundred units. However, profit margins also increase. Clearly, there must be some other sources of significant cost savings or scale economies for large builders. Indeed, large builders do have potential advantages in many areas, including:

- Bulk material purchases, especially in appliances and mechanical equipment;
- Negotiating strength with subcontractors and suppliers;
- Better organization of work;
- Better marketing and market research;
- Less costly construction financing;
- The ability to amortize architectural and engineering design costs over more homes;
- Continuity of operations from multiple projects;
- Ability to purchase larger tracts of land;
- Risk diversification across projects.

---

<sup>18</sup> *Standard & Poor's Industry Surveys: Building & Forest Products*, Vol. 161, No. 31, Sec. 1, August 5, 1993.

The sources of these cost advantages generally tend to be different from the scale economies enjoyed by mass manufacturers, which are derived from production technologies. In fact, The National Association of Homebuilders has reported that there is *no* apparent economy of scale in production.<sup>19</sup>

Annual Volume (# of units)	1-9	10-24	25-99	100+
Overhead as % of Total Cost	2.5	4.3	5.2	8.0
Profit as % of Sales	5.7	6.7	8.5	10.0

**Table 2-2: Cost Variations with Builder Size<sup>20</sup>**

Although small firms have disadvantages in many areas, they remain in the marketplace due to their high flexibility and their very low overhead.<sup>21</sup>

## 2.4 Construction Materials Breakdown

As shown in Table 2-1, construction materials represent between thirty and thirty-five percent of overall housing cost. Many reports, based on U.S. Department of Commerce input-output account data,\*\* have been compiled to show the breakdown of these material costs in homebuilding. Table 2-3 presents such a breakdown.<sup>22</sup> It shows which materials command the most of housing's dollars. It is useful to note that general sawmills and planing mills (which produce dimensional lumber) represent twice as much material cost as the second largest contributor (ready-mixed concrete).

---

<sup>19</sup> National Association of Home Builders, *Strategic Issues for Home Builders, 1990-1992 and Beyond*, 1990.

<sup>20</sup> Grebler, Leo. *Large Scale Housing and Real Estate Firms*, Praeger Publishers, New York, 1973, Chapter 3.

<sup>21</sup> MacAuley, Patrick H., "Economic Trends in the Construction Industry, 1965-80," *Construction Review*, May-June, 1981.

\*\* See Section 2.5 for a description of this data.

<sup>22</sup> Williams, Franklin E., "The 1977 Input-Output Profile of the Construction Industry," *Construction Review*, July-August, 1985.



Input Category	% of total
General sawmills and planing mills	17.58%
Ready-mixed concrete	8.34%
Millwork	7.77%
Veneer and plywood	6.80%
Prefabricated wood buildings	4.55%
Refrigeration and heating equipment	3.42%
Metal doors, sash and trim	3.28%
Wood kitchen cabinets	3.28%
Textile floor coverings	2.96%
Paints and allied products	2.70%
Architectural metal work	2.67%
Asphalt felts and coatings	2.18%
Hardware, not elsewhere classified	2.06%
Mineral wool	2.01%
Plumbing fixture fittings and trim	1.91%
Concrete block and brick	1.80%
Petroleum refining and misc. products of petroleum and coal	1.62%
Miscellaneous plastics products	1.61%
Lighting fixtures and equipment	1.58%
Wiring devices	1.54%
Switch gear and switchboard apparatus	1.45%
Brick and structural clay tile	1.36%
Gypsum products	1.22%
Iron and steel foundries	1.14%
Non-ferrous wire drawing and insulating	1.11%
Steel wire and related products	1.02%

**Table 2-3: Construction Material Cost Breakdown, 1977**

Components that are pre-assembled off-site constitute a significant portion of the value added in materials. Pre-assembled components include millwork items such as windows and pre-hung wooden doors, prefabricated wood buildings, refrigeration and heating equipment, pre-hung metal doors, wood kitchen cabinets, and others. Together, these components comprise over twenty percent of material costs.

While these tables can be useful, they can also be somewhat deceptive when compared to the underlying input-output data. The percentages represent a portion of total *material* cost (which represents only about one-third of housing cost) and not total construction cost. An examination of the underlying input-output data reveals that each category of material cost is dominated by several other sources of cost. The result, as described in Section 2.5, is a vastly different breakdown of *construction* costs.

## 2.5 Input-Output Analysis

Every five years since 1947, the U.S. Commerce Department's Bureau of Economic Analysis (B.E.A.) has published detailed input-output tables that use a six-digit industry classification. "Input-output" refers to an identification of those industries that provide

factor inputs for a given industry, as well as their respective proportions. In addition, it includes an identification of the industries that use the output of a given industry as factor inputs. However, since it takes about seven years to compile the publication, the tables are somewhat dated at their time of release. To help alleviate this problem, the Bureau of Labor Statistics (B.L.S.) Office of Employment Projections also keeps some very similar (but unpublished) data for certain intermediate years. While these intermediate year tables are more current, the detailed compiled census year tables are reportedly more accurate than the intermediate year data. Nonetheless, the analysis below refers to both sources.

There are two additional complications with the available data sources. The classifications used in the detailed B.E.A. publications have changed slightly from year to year, and the intermediate year data is not available to the same level of detail as the census year reports. Therefore, it is somewhat difficult to make temporal comparisons. Nevertheless, the input-output analysis below is based on three sources of data: *The Detailed Input-Output Structure of the U.S. Economy, 1977*, based on a 534 industry classification; *The 1982 Benchmark Input-Output Accounts*, based on a 541 industry classification; and unpublished B.L.S. Office of Employment Projections intermediate year tables for 1977, 1987, and 1990, based on a 228 industry classification. Despite these difficulties, analysis of the data yields some useful insights. Note that the analysis focuses on the industry sector representing new, non-farm, single-unit housing.

### **2.5.1 Benchmark Input-Output Accounts**

Housing market input-output data and statistics help identify where money is being spent in the construction phase of homebuilding (about half of total housing cost). Table 2-4 shows a breakdown of housing's factor inputs. It is based on data published in the *1982 Benchmark Input-Output Accounts*, which represents the most current compiled and published source of detailed data. Note that 1982 was a recession year for housing.

It is reassuring that the input-output data is in agreement with Table 2-1, which presented the cost breakdowns reported by builders. For example, material cost is estimated in Table 2-1 to be thirty-three percent of housing cost, or roughly sixty-six percent of construction cost. In Table 2-4 the corresponding estimate is 65.3 percent (Material cost is computed by subtracting labor cost and profit type income from one hundred percent.). Table 2-1 estimates labor cost at roughly nineteen percent of housing cost, or thirty-eight percent of construction cost. In Table 2-4, the estimate averaged roughly forty percent, except for the 1982 census year, in which the estimate was 23.7 percent. This might be due to the fact that 1982 was a recession year for housing. In such a market, subcontracted labor is in oversupply and is typically less expensive.

The principal finding shown in Table 2-4 is that individual categories of material costs represent small portions of construction costs. As shown in the table, they are dominated by labor costs and distribution chain costs (wholesale and retail trade), which represent inventory costs, handling costs, and markup.

<b>Commodity Used in Construction</b>	<b>% Value</b>
Compensation of employees	23.7%
Retail trade, except eating and drinking	11.9%
Profit type income, net interest, and capital consumption allowances	11.0%
Wholesale trade	5.0%
Sawmills and planing mills, general	5.0%
Ready mixed concrete	4.0%
Millwork	3.0%
Motor freight transportation and warehousing	1.7%
Veneer and plywood	1.7%
Wood kitchen cabinets	1.5%
Engineering, architectural, and surveying services	1.5%
Metal doors, sash, and trim	1.3%
Petroleum refining	1.3%
Prefabricated wood buildings	1.2%
Floor coverings	1.0%
Eating and drinking services	1.0%
Paints and allied products	0.9%
Asphalt felts and coatings	0.9%
Miscellaneous repair shops	0.9%
Refrigeration and heating equipment	0.9%
Plumbing fixture fittings and trim	0.8%
Wiring devices	0.8%
Sheet metal work	0.8%
Other	18.2%

**Table 2-4: Use Table for Residential One-unit Structures, 1982**

Note that in Table 2-4, the contribution to cost of sawmills and planing mills is not double that of ready-mixed concrete, as shown in Table 2-3 above. Instead, it represents only 1.25 times the cost share of concrete. This can be explained by the fact that ready-mixed concrete cost includes transportation cost — concrete suppliers deal directly with builders, so they manufacture and distribute the product. If these proportions are correct, we can estimate that three-eighths of the delivered cost of products from sawmills and planing mills are attributable to wholesale and retail trade. However, there are certainly no retail markup or extra handling or inventory costs associated with the two-tiered distribution system of other materials.

In light of this information, a potential strategy for reducing homebuilding costs might be to reduce wholesale and retail trade costs by linking material and component manufacturers directly to builders. A more detailed analysis of the cost tradeoffs in the production and distribution value system is needed, including a consideration of logistics issues. Nonetheless, to achieve such a direct linkage, manufacturers must be flexible enough to supply the products just-in-time and in customized configurations. Ready-mixed concrete producers have achieved just this level of flexibility. Builders usually call a ready-mixed concrete supplier twelve to twenty-four hours in advance of the desired

delivery time. They specify product attributes such as desired concrete strength, aggregate gradation, admixtures, quantity, and delivery time. To some extent, the perishable nature of concrete has forced concrete producers to use such a flexible manufacturing system. The potential for expanding this approach to other materials and components will be discussed further below.

Another interesting finding shown in Table 2-4 is the wide range of industries that supply residential construction. Houses are very complex products. They require numerous types of materials and components, as evidenced by the large aggregate percentage of overall construction cost that is attributable to industries that contribute small individual amounts to cost. For example, components that individually contribute less than one percent to cost collectively comprise 24.2 percent of construction cost. Likewise, components that individually contribute less than 0.8 percent to cost represent 18.2 percent of cost.

### **2.5.2 Trends in Cost Breakdowns**

Industry trends, as well as the precision of the above data, can be inferred from an examination of some key cost components over time. As mentioned above, the limited availability of consistent classifications makes this type of analysis difficult. The table below compares data from all utilized sources for some of the key components that make up relatively large shares of cost.

Table 2-5 reveals some inconsistencies between the sources of data with regard to retail and wholesale trade. The data series from the Office of Employee Projections are consistent regarding the classifications, but disagree with the 1977 and 1982 detailed and benchmark sources. Also, the 1977 and 1982 benchmark figures are inconsistent individually, but they agree in total. These apparent discrepancies may be explained by the fact that 1982 was a recession year in housing, while 1977 and 1987 were high volume years. It is possible that builders bought materials in smaller quantities at retail price rather than at wholesale during the recession. It is also possible that the wholesale and retail sector classifications changed slightly between 1977 and 1982, since the sums compare exactly. Also, to reiterate, the Office of Employee Projections intermediate year data is not as accurate as the 1977 and 1982 detailed and benchmark sources.

The data in Table 2-5 is consistent regarding many of the components that are currently being pre-assembled off-site, including kitchen cabinets, millwork (primarily windows and doors), and prefabricated wood buildings. Combined, these components represent about six percent of construction cost in both 1977 and 1982, or roughly three percent of overall housing cost. This corresponds to roughly six billion dollars.

	Current Dollars % of Total				
	Office of Employment Projections			Detailed	Benchmark
	1977	1987	1990	1977	1982
Value added	39.4%	42.0%	40.5%	45.8%	
Compensation of employees					23.7%
Profit, net interest, and capital consumption					11.0%
Engineering, architectural, and surveying services	2.5%	4.9%	6.2%	3.3%	1.5%
Wholesale trade	5.9%	5.7%	6.0%	10.2%	5.0%
Retail trade, except eating and drinking	5.9%	5.7%	5.7%	6.7%	11.9%
Sawmills and planing mills, general	6.9%	5.1%	4.8%	9.0%	5.0%
Millwork and structural wood members, n.e.c.	4.2%	5.1%	5.5%		
Millwork				3.2%	3.0%
Wood kitchen cabinets				1.3%	1.5%
Veneer and plywood	2.5%	1.8%	1.8%	3.7%	1.7%
Cement, concrete, gypsum, and plaster products	4.8%	5.0%	4.8%		
Ready mixed concrete				3.5%	4.0%
Gypsum products					0.4%
Stone, clay, and misc. mineral products	2.0%	1.6%	1.6%		
Concrete block and brick					0.5%
Brick and structural clay tile					0.3%
Dimension, crushed and broken stone					0.3%
Prefabricated wood buildings	1.7%	1.1%	1.0%	1.8%	1.2%
Paints and allied products	1.0%	0.9%	0.9%	1.3%	0.9%

**Table 2-5: Input-Output Cost Trends**

Table 2-5 suggests that the housing industry consistently spends a large portion of construction cost in the materials distribution value chain, specifically for wholesale and retail trade. As mentioned above, these represent areas for potential savings. While the above data are somewhat inconsistent regarding these categories, the sources suggest that when combined, wholesale and retail trade costs represent between eleven and seventeen percent of housing construction cost. Wholesale trade consists of costs associated with warehousing materials — primarily the labor cost for moving materials into and out of warehouses. Retail trade consists of costs for warehousing and merchandising the materials. Again, labor is the primary cost.

Costs incurred in the distribution value chain may represent the most compelling reason to adopt flexible manufacturing systems for component production. Manufacturers could deal directly with builders, eliminating the need for these “middlemen” and the costs associated with the extra handling of materials. One or more of the following criteria should be met for components to be distributed directly from this type of flexible manufacturer:

- Product will "spoil," such as ready-mixed concrete

- Product can be differentiated
- Product is a significant contributor to quality or cost
- Customization can be used to meet a customer's unique cost or quality requirements
- Wholesale and retail trade costs are significant

Numerous items satisfy these criteria and could potentially be fabricated and distributed just-in-time directly from the manufacturer. These include: prefabricated wood buildings; value-added wood components such as trusses and wall panels; millwork (primarily wooden windows and doors), wood kitchen cabinets; and, metal doors, sash, & trim.

According to the data in Table 2-5, these components make up roughly thirteen percent of purchased materials. Assuming that the new approach completely eliminated retail and wholesale trade for these items, overall construction costs could fall by 1.4 percent (thirteen percent of the eleven percent distribution cost). This would correspond to roughly a 0.7 percent decrease in overall housing cost (or roughly 1.4 billion dollars), not including any direct cost savings in the production of the components.

Although dimensional lumber, veneer and plywood, and a small portion of millwork (wood moldings and trim) will probably still be mass produced, their production and distribution value chains may also have room for improvement. Although these items are not easy to differentiate, flexible manufacturing technologies may potentially affect how the industry delivers these products. Since flexible manufacturing systems typically lower the minimum efficient scale of production, it is possible that “mini-sawmills” could be developed that could compete with the large national sawmills, as mini-mills have in the U.S. steel industry. As new materials such as plastics begin to be used more for these components, these mini-factories may simply become molders of plastic parts. The economics of the production and distribution of these products should be examined in more detail, although it is beyond the scope of this thesis.

## 2.6 Industry Flexibility

If one had to characterize the homebuilding industry in a single word, that word would be flexible. The homebuilding industry, in its current form, responds to numerous sources of variation and produces almost infinite variety. This section seeks to characterize some of the types of flexibility in the industry.

Suarez, Cusumano, and Fine provide a thorough survey and critique of flexibility literature, with an emphasis on the interaction between flexibility and strategic issues.<sup>23</sup> They state, “Flexibility is a multi-dimensional concept.” Flexibility refers to much more than just diversity of physical product attributes. The authors further state, “A common

---

<sup>23</sup>Suarez, Fernando F., Michael Cusumano, and Charles H. Fine, "Flexibility and Performance: A Literature Critique and Strategic Framework," MIT Sloan School of Management Working Paper Number 3298-91-BPS, Version: November 1, 1991.

weakness in most empirical studies on flexibility is that they consider flexibility in isolation from efficiency and quality.” The analysis in this thesis considers flexibility measures in conjunction with measures of the other key manufacturing attributes: quality, time, and cost. These four types of attributes should be considered together when making manufacturing decisions<sup>24</sup>

Many types of flexibility are identified in the literature. Several of these which describe types of production process flexibility are discussed briefly below, including volume flexibility, mix flexibility, new product flexibility, delivery time flexibility, routing flexibility, material flexibility, and sequencing flexibility. The degree to which the housing industry currently exhibits each type of flexibility is also described.

### **2.6.1 Volume Flexibility**

Volume flexibility refers to the ability of a production system to operate profitably at varying production rates. Related to this concept, or perhaps an extension of this concept, is the ability to increase and shrink the capacity of the production system. A system with inherently lumpy capacity, such as a typical factory in the pulp and paper industry, has difficulty matching demand fluctuations.

Clearly, as discussed in Section 2.1.2, the housing industry responds to large fluctuations in volume, aided by the fact that huge numbers of firms simply exit the industry in response to inadequate demand. Component producers such as truss manufacturers tend to under-invest in plant and equipment (fixed costs), relying instead on substantial inputs of labor, which is easier to eliminate in times of low demand.

### **2.6.2 Mix Flexibility**

Mix flexibility refers to the ability to produce a variety of products with the same production system. For the homebuilding industry as a whole, there is a high degree of mix flexibility. It is appropriate to describe mix flexibility, in this context, as the ability to produce products with variety rather than a variety of products, since each house is different in some way. However, the primary source of mix flexibility is the fragmented nature of the industry and its suppliers. In other words, there are numerous design choices and numerous suppliers. However, the mix flexibility of *individual* builders and suppliers is limited in spite of their large reliance on labor (the most flexible machine available).

### **2.6.3 New Product Flexibility**

This type of flexibility refers to the ability of a production system to accept additions to and subtractions from the mix of products. Material suppliers regularly introduce new

---

<sup>24</sup> Chryssolouris, George, *Manufacturing Systems, Theory and Practice*, Springer-Verlag, New York, 1992.

building products to homebuilders. The speed of adoption is somewhat slow, but this is due to market risk and related issues, rather than technical constraints imposed by the production system. The on-site system of production exhibits high new product flexibility.

#### **2.6.4 Delivery Time Flexibility**

Delivery time flexibility refers to the ability of a system to fast-track an order if required by a customer. In homebuilding, delivery time is not very flexible. Construction duration is somewhat established. There is little ability to speed to the process substantially and efforts to do so usually result in increased cost and decreased quality.

#### **2.6.5 Routing Flexibility**

Routing flexibility is the ability to reroute a part to other production resources when a portion of the system is unavailable. The homebuilding industry is flexible in this regard due to its wide distribution of production capabilities. In other words, when one firm or subcontractor is unable to complete a task, another firm can step in and provide productive capability.

#### **2.6.6 Material Flexibility**

Material flexibility is the ability to accept materials that vary. In homebuilding, the materials are not dimensionally precise. In fact, the production system and the product itself (specifically the interfaces and connections between components) are designed precisely to accommodate such material variability.

#### **2.6.7 Sequencing Flexibility**

Sequencing flexibility is the ability to rearrange the order that parts enter the system. In homebuilding, sequencing flexibility is somewhat low. There is a standard process flow with relatively fixed precedence relationships. Altering these is usually not possible.

### **2.7 Summary**

The housing industry is large in both dollar volume and the total number of housing units produced. In addition, it is extremely fragmented, even on a regional basis. Construction cost comprises only about half of total housing cost. Other contributors to cost include land, regulatory costs, marketing, and finance costs, many of which are beyond the control of the builder.

The housing industry is extremely flexible, exhibiting high degrees of numerous types of flexibility. This flexibility allows it to respond to the large fluctuations in demand and the wide variability of the product.

A large number of industries supply products for homebuilding, with most individual materials comprising a small contribution to housing cost. However, a significant portion



of construction cost is attributable to coordinating the flow of these constituent materials from the numerous suppliers to the builders. It is possible that new flexible production technologies could significantly alter the economics of production and distribution, shortening the link between material manufacturers and builders. In an industry with roughly forty percent value added in production, improvements could be significant.

Components that are pre-assembled off-site constitute a significant portion of the value added in materials. Pre-assembled components include millwork items such as windows and pre-hung wooden doors, prefabricated wood buildings, refrigeration and heating equipment, pre-hung metal doors, wood kitchen cabinets, and others. Together, these components represent a significant class of input to the housing industry.

## 3. Analysis of Supplying Industries

### 3.1 Introduction

Statistically, off-site production of *housing* captures only a small portion of the total residential building market. In 1990, for example, the top four hundred builders in the U.S. produced over twenty-nine billion dollars worth of site-built single family homes (sixty-three percent of revenues) and just over three billion dollars worth of off-site produced housing (seven percent of revenues).<sup>1</sup> The off-site produced housing included 2.6 billion dollars (5.7 percent of revenues) worth of mobile homes, 341 million dollars (0.7 percent of revenues) worth of modular houses, 185 million dollars (0.5 percent of revenues) of panelized housing, and only fifty-two million dollars (0.1 percent of revenues) worth of precut housing. However, these statistics do not represent the tremendous amount of value added off-site in production of materials and components for the site-built homes. All homes contain components that are produced and assembled off-site, including trusses, cabinets, windows, mechanical systems, and others. It is the value of these components that greatly increases the importance of off-site operations.

Chapter Three extends the economic analysis contained in Chapter Two into some of the industries that supply the homebuilding industry with components. In particular, this Chapter provides a detailed examination of the structure of four key supplying industries: prefabricated wood buildings, millwork, wood cabinets, and ready mixed concrete. The components produced by each of these industries are customizable, differentiable, and represent significant contributors to cost. Furthermore, the products are usually either customized or custom designed and ordered. Builders and architects custom design products such as prefabricated wood buildings, wooden wall panels, and roof trusses, configuring them specifically for the installation. In contrast, builders order customized products, such as windows and wood kitchen cabinets, from a predefined range of styles. Ready-mixed concrete is discussed for comparison, since it is currently produced with what is essentially a flexible manufacturing system.

Much of the following statistical data was taken from *Manufacturing USA*, 3rd Edition, a compilation of industry analyses and statistics published by Gale Research, Inc.<sup>2</sup>

---

<sup>1</sup> "Annual Report of Housing's Giants." *Professional Builder and Remodeler*. July 1, 1991.

<sup>2</sup> Darnay, Arsen J., Editor, *Manufacturing USA: Industry Analyses, Statistics, and Leading Companies*, Volume 1, SIC 2011-3299. 1993.

## 3.2 Prefabricated Wood Buildings / Mobile Homes

The prefabricated wood building industry, SIC 2452,<sup>3</sup> produces modular housing, panelized and precut homes (including wood truss manufacturing), and other pre-manufactured structures for non-residential uses. In 1987, about sixty-five percent of industry output (in dollar volume) was residential, seventeen percent was nonresidential, and eighteen percent was non-specified. The nonresidential segment of modular production typically focuses on commercial buildings such as small retail, convenience stores, and fast food buildings, temporary classroom buildings, and other similar small structures. This segment markets itself under the name of "special unit" producers.

Roughly thirty-three percent of the output of SIC 2452 (in dollars) consisted of complete, three dimensional assemblies (modular units). Eighteen percent consisted of complete units in panel form (panelized construction). Sixteen percent consisted of precut

**Precut homes** are essentially framing "kits" containing the necessary framing members cut to the correct size and labeled for easy manual assembly. These kits range in sophistication from log cabin style homes, with pre-notched logs, to traditional architecture utilizing finished lumber. Precut homes are the least complete of the four sub-categories, with much of the construction performed on site.

**Panelized homes** are produced from prefabricated panels. Panels are classified as either open or closed. Open panels are basically framed walls, while closed panels include wiring, plumbing, insulation, and drywall. Panelized homes have the advantage of being compact for shipping relative to modulars, but can be much more complete than precut homes when they leave the factory.

**Modular homes** are virtually complete when delivered to the site. They are trucked to the site in large "box" segments and are assembled with a crane. Modular erectors then bolt the homes to traditional, permanent foundations. The interiors are complete, (fully painted, carpeted, etc.) and appliances are typically included. Modular homes, while more difficult to transport, eliminate virtually all on-site operations except for site work, foundations, and utility connections.

**HUD code, or mobile homes** are also completely prefabricated homes. They typically contain an integral trailer and wheels, and are towed to the site. However, people seldom move mobile homes from their original location. Mobile homes are usually supported by piers, rather than being anchored to a standard strip footing. The primary feature that separates HUD code homes from the above three types is that they are designed in accordance with a national preemptive building code, known as the HUD Code. Thus, the law does not require them to satisfy local building codes.

<sup>3</sup>SIC refers to the Standard Industry Classification of the U.S. Department of Commerce.

packages, and eighteen percent represented component manufacturing (incomplete units such as roof trusses, floor trusses, and/or wall panels). The configuration of about fifteen percent of output was non-specified. However, the modular segment represents a much lower proportion of the number of housing units due to the higher unit price (of a complete unit) compared to panelized, precut, and component production.

The mobile home industry, SIC 2451, produces homes that differ from prefabricated wood (modular) buildings in two primary ways. First, the homes usually contain a metal frame structure that also functions as the trailer for transporting the unit to the site. However, contrary to popular opinion, mobile homes are almost never "mobile." Practically all mobile homes built today rest on permanent foundations. The second difference is that the homes satisfy a national preemptive building code for this type of structure, known as the HUD Code. In contrast, modular buildings must satisfy the local building codes.

The mobile home industry also focuses more on the residential market than the prefabricated wood building industry does. About eighty-six percent of mobile homes produced in 1987 were residential, six percent had nonresidential uses, and eight percent were non-specified.

### 3.2.1 Size

According to Department of Commerce data, the prefabricated wood building industry was a 1.3 billion dollar industry in 1982. Since the industry produces a variety of outputs, the breakdown of this industry by value of product shipped is somewhat imprecise. However, some other sources of data are available that classify output by product type.

According to the National Association of Homebuilders and as shown in Table 3-1, 12.4 percent of the housing units started in 1986 utilized some type of prefabricated building system,<sup>4</sup> with very strong regional differences. The report provided no explanation for the regional differences. What is clear from the table is that overall, panelized housing units outnumbered modular units by almost three to one, with precut units being roughly twenty-five percent more popular than modular units.

	U.S.	Northeast	Midwest	South	West
<b>Modular</b>	2.4%	1.6%	4.8%	1.7%	0.4%
<b>Panelized</b>	7.0%	20.6%	8.9%	9.2%	1.2%
<b>Precut</b>	3.1%	0.6%	0.7%	5.7%	2.8%
<b>Total</b>	12.4%	22.8%	14.3%	16.6%	3.4%

**Table 3-1: Building Systems Starts**

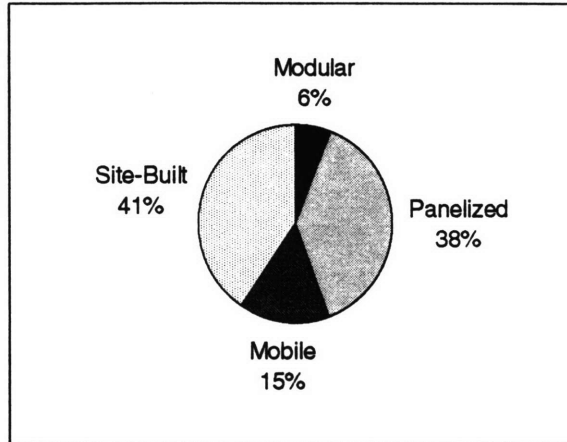
Note that Table 3-1 only includes the production of complete housing units. If the data included site-assembled housing units that incorporate off-site assembled components

---

<sup>4</sup> *The Future of Home Building, 1992-1994 and Beyond*, National Association of Homebuilders, Washington, D.C., 1992.

produced by SIC 2452 (such as roof or floor trusses), the percentage would be nearly one hundred percent.

According to another N.A.H.B. sponsored report, shipments of modular homes have averaged twenty-six thousand units from 1984 to 1989, while panelized homes averaged 130,000 units.<sup>5</sup> Since during this time new home starts averaged 1.63 million units annually, these Figures correspond to a 1.6 percent market share for modular homes and an eight percent market share for panelized homes. Both estimates are in reasonable agreement with the first report.



**Figure 3-1: Automated Builder's 1992 Market Breakdown by Housing Type**

A third source, *Automated Builder Magazine* (an industry trade publication), states that the U.S. housing market can be classified as shown in Figure 3-1.<sup>6</sup> According to that breakdown, modular housing represents six percent of the U.S. housing market, with panelized construction comprising thirty-eight percent of the market. Clearly, classification of housing types has created some ambiguities in the exact breakdown of the market size.

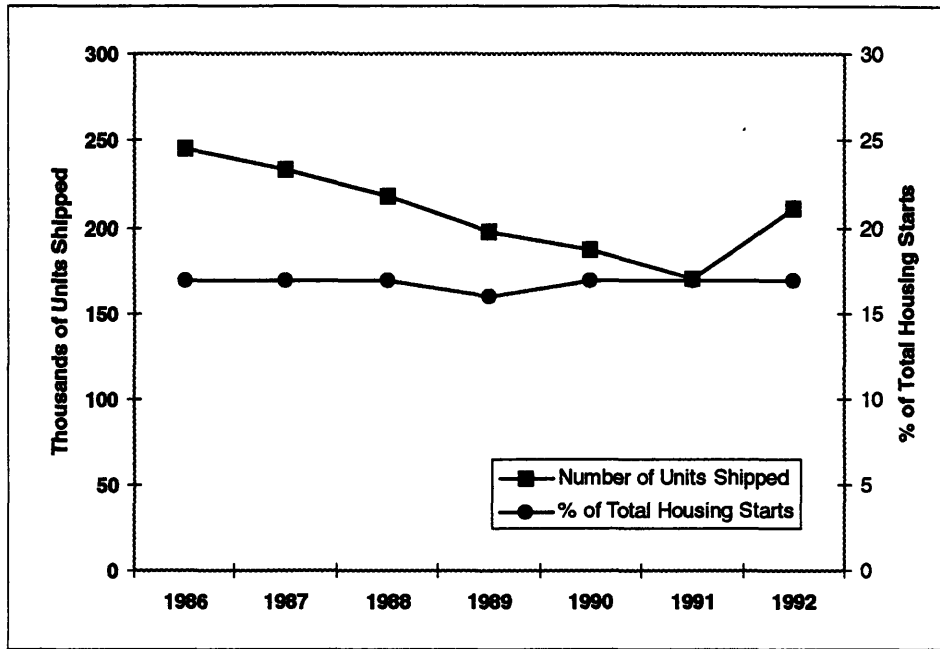
Compared to the modular home market, the mobile home industry is relatively large. As shown in Figure 3-2, shipments of mobile homes have averaged roughly 235,000 units per year (nine times greater than modular shipments), at a volume of roughly 5.5 billion dollars. Variability in sales has roughly followed that of total housing units. In fact, mobile home shipments have been steady at seventeen percent of the market (in terms of number of units) between 1986 and 1992, except for 1989, when they represented sixteen percent.<sup>7</sup> This data basically agrees with the data from *Automated Builder* shown in Figure 3-1.

---

<sup>5</sup> *Factory Built Housing in the 1990's*, Report by Hallahan Associates for the Building Systems Council of the National Association of Homebuilders, September, 1990.

<sup>6</sup> *Automated Builder*, December, 1993.

<sup>7</sup> "Building & Forest Products," *Standard & Poor's Industry Surveys*, Vol. 161, No. 31, Sec. 1, August 5, 1993.



**Figure 3-2: Mobile Home Shipments**

### 3.2.2 Firms

Firms in the prefabricated wood building industry tend to be larger than most site builders, but smaller than most mobile home producers. Roughly thirty-five percent of establishments surveyed in the past ten years reported having twenty or more employees. In comparison, 315 of the 395 reported mobile home producers (eighty percent) had twenty or more employees.

The mobile home manufacturing industry is also far less fragmented than the site built construction industry and the prefabricated wood building industry, with consolidation ratios as shown in Table 3-2.

$C_5$	46%
$C_{10}$	62%
$C_{25}$	83%

**Table 3-2: Consolidation Ratios of Mobile Home Manufacturing Industry**

In addition, the industry is continuing to consolidate, with the number of firms falling consistently since 1982 and the percentage of firms with twenty or more employees following an upward trend. It would be interesting to study this industry further to identify causes of this consolidation, especially since no trends toward industry consolidation are evident for modular home producers.

The mobile home manufacturing industry relies heavily on low skilled workers and manual production operations. In 1989, the average establishment had over 2.5 times the number of production workers in an average manufacturing firm. In addition, the average worker

received only seventy-eight percent of the average manufacturing wage. In addition, capital investment is low and has fallen sharply since 1986. For example, in 1989 investment per production worker was only ten percent of the average for all manufacturing industries.

In contrast, in 1989, the number of production workers per establishment for firms classified in the prefabricated wood building industry was sixty-nine percent of the average for all manufacturing industries. This implies that scale economies may be less significant than in mobile home production or in other industries. Production workers received only seventy-eight percent of the average manufacturing wage, indicating the same below-average skill levels found in mobile home production. Compared to mobile home manufacturing, capital investment was higher in 1989, but still low at only thirty-two percent of the amount invested by other industries. Low capital investment certainly contributes to the low value added per production worker (which equals only fifty-one percent of the average of all manufacturing industries).

Table 3-3 shows the classification by occupation of workers who produce prefabricated wood buildings and mobile homes. In 1990, the leading categories were assemblers and fabricators at twenty-six percent and carpenters at 18.7 percent. The interesting portion of the table is the column of workforce changes projected by the U.S. Department of Commerce Bureau of Labor Statistics. The B.L.S. has projected significant reductions in the need for many task-oriented workers. These reductions are presumably caused by increasing use of three types of automation: design automation (drafters); production automation (assemblers and fabricators, carpenters, plumbers, and blue collar supervisors); and office automation (secretaries, bookkeeping, accounting and auditing). The B.L.S. has projected major increases in salespeople, as well as in industrial production managers, who will manage the new, increasingly complex automated production operations.

Occupation	% of Total, 1990	Estimated % Growth or Decline by 2005
Assemblers and fabricators, n.e.c.*	26.0	-24.8
Carpenters	18.7	-3.0
Extraction & related workers	5.1	-3.3
Supervisors of blue collar workers	4.1	-3.2
Sales & related workers, not elsewhere classified.	3.7	20.3
Helpers, construction trades	3.4	0.9
Electricians	2.9	8.2
Cabinetmakers & bench carpenters	2.4	3.9
General managers & top executives	2.0	-7.6
Plumbers, pipefitters, & steamfitters	1.9	-4.0
Truck drivers, light & heavy	1.9	7.2
Drafters	1.8	-14.0
Secretaries	1.4	-14.1
Painters & paperhangers	1.3	1.0
Industrial production managers	1.3	17.0
Head sawers, sawing machine operators, tenders	1.2	7.5
Industrial truck & tractor operators	1.1	-3.8
Sheet metal workers & duct installers	1.1	7.5
Maintenance repairers, general utility	1.1	-6.8
Bookkeeping, accounting, & auditing clerks	1.0	-26.5

**Table 3-3: Occupations Employed to Manufacture Prefabricated Wood Buildings and Mobile Homes**

In contrast to site builders, prefabricated wood building producers and mobile home producers do not rely on construction financing to fund production. They operate with internal working capital. Two of the largest mobile home producers reportedly have “huge cash positions and no long term debt.”<sup>8</sup> In contrast, site builders almost always finance operations with project specific construction loans (only fifteen percent of the *largest* four hundred builders reported using retained earnings).<sup>9</sup>

### 3.2.3 Cost of Production

The input-output analysis of prefabricated wood buildings is described below and is presented in Table 3-4 for comparison to the site-built data. Compensation of employees represented twenty-five percent of total inputs, followed by profit, income, and capital consumption, at 14.7 percent. Wholesale trade comprised 6.6 percent. Wood was the

---

\* “not elsewhere classified”

<sup>8</sup> “Building & Forest Products,” *Standard & Poor's Industry Surveys*, Vol. 161, No. 31, Sec. 1, August 5, 1993.

<sup>9</sup> “PB&R's 26 Annual Report,” *Professional Builder & Remodeler*, July, 1993.



dominant material input, as would be expected, with a contribution of 17.6 percent (Sawmills and planing mills, 14.1 percent, and veneer and plywood, 3.5 percent).

Prefabricated wood buildings represent an insignificantly small source of input to homebuilding in Table 2-4. However, they represent a potential substitute product for site built housing. Improving production of this “component” could potentially allow it to obtain a much larger percentage of housing construction cost. Such a substitution would represent a redistribution of costs from the breakdown shown in Table 2-4 to the breakdown for the prefabricated wood building industry, shown in Table 3-4. However, it would only encompass the construction of the superstructure. Foundation and site work costs would be unchanged.

Description of commodity used	% Value
Compensation of employees	25.0%
Profit type income, net interest, and capital consumption allowances	14.7%
Sawmills and planing mills, general	14.1%
Wholesale trade	6.6%
Veneer and plywood	3.5%
Metal doors, sash, and trim	3.0%
Fabricated structural metal	3.0%
Advertising	2.6%
Millwork	2.6%
Motor freight transportation and warehousing	1.5%
Hardwood dimension and flooring mills	1.5%
Mineral wool	1.4%
Other non-farm buildings maintenance & repair	1.3%
Gypsum products	1.1%
Sheet metal work	1.1%
Refrigeration and heating equipment	1.0%
Hardware, not elsewhere classified	1.0%
Railroads and related services	1.0%
Asphalt felts and coatings	1.0%
Other	13.0%

**Table 3-4: Cost Breakdown for Prefabricated Wood Buildings**

Table 3-4 differs slightly from Table 2-4. Most categories, including labor costs and wholesale trade, are roughly the same. This is not surprising since both production methods utilize largely equivalent materials and technologies. Material costs, most notably those represented by sawmills and planing mills, represent slightly larger fractions of total cost. Again, this is not surprising since the data does not include foundation material cost. The most significant difference between the breakdowns is that the retail trade cost is absent entirely in production of prefabricated wood buildings. Since prefabricators have a fixed location and a fairly large scale compared to site builders, they are able to buy materials either directly from manufacturers or from wholesalers.

Another interesting fact shown in Table 3-4 is the small (1.5 percent) contribution to cost made by motor freight transport. Many critics of modular housing and off-site production cite the high cost of shipping the products to the site, which in reality may be overstated.

### **3.2.4 Potential for Improvement**

Value added represents roughly forty percent of total cost, while material costs total thirty-five percent, outside services equal twelve percent, and thirteen percent of cost is unclassified. Since value added is significant, there may be substantial opportunities for improving production efficiencies.

#### ***3.2.4.1 Shift in Cost Structures***

Since prefabricated wood buildings represent a potential substitute product for site-assembled housing, it is possible that the cost structure for prefabricated wood buildings could partially replace the cost structure for site-assembled housing. This would result in savings due to the elimination of retail trade costs. However, since otherwise the cost structures are similar, the amount of benefit or improvement would be minimal. Given the inability of prefabricated buildings to capture market share, this should not be surprising. If the cost structure was significantly better, market mechanisms would force production to shift to the more efficient method (at least in the long term). Thus, prefabricated wood buildings would represent a growing mode of supply.

A significant factor hindering the growth of prefabricated wood buildings is the lack of flexibility of the production system. Customization is fairly limited in modular home production and even more so in mobile home production, due primarily to the rigid assembly line structure of the production operations (which is discussed in Chapter Four). A move to a cellular manufacturing approach would enable increased flexibility but would require additional production coordination. Automated process planning and control could be used to coordinate and manage such an operation. Increased flexibility would improve the ability of modular housing to substitute for site-assembled housing.

#### ***3.2.4.2 Shift in Factor Inputs***

Prefabricated wood buildings are important because of the potential for *changes* in the production cost structure. In both on-site production and off-site production, value-added represents roughly forty percent of the cost. However, prefabricated wood buildings have the higher potential for shifting factor inputs to more efficient resources through automation of off-site activities.

Numerous authors have established that it is easier to implement automation in an off-site factory than on a construction site. The reasons include the following:<sup>10</sup>

---

<sup>10</sup> Demsetz, Laura Ann, "Task Identification and Machine Design for Construction Automation," Ph.D. Thesis, MIT Department of Civil Engineering, 1989.

- the ability to control the environment of the factory, including the temperature, humidity, lighting, etc.;
- the fact that the layout of the off-site workplace does not vary from day to day, as it does on the jobsite;
- the fact that the factory workforce is comparatively stable throughout a job and between jobs;
- that off-site, equipment and workers do not need to move around a large stationary product and from project to project, greatly simplifying system design issues such as accuracy and repeatability.

For these and other reasons, the feasibility of automating off-site operations is simply higher than that for on-site operations.

#### ***3.2.4.3 Financial Considerations***

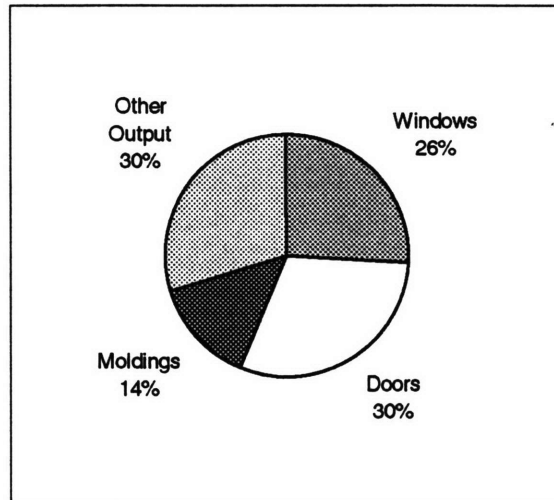
The mobile home industry is an attractive target for the adoption of flexible manufacturing technologies and philosophies because of its significant scale and market consolidation, combined with the favorable cash positions of its market leaders. Likewise, the apparent lack of capital investment by both the mobile home industry and the prefabricated wood building industry would suggest that neither has a vested interest in current production technologies. On the other hand, the lack of a skill base in the work force may constrain or delay the implementation of sophisticated options. In either case, the current mode of production and the established distribution chain are very rigid. Therefore, such an adoption would require a significant shift in operating philosophy throughout the value chain.

### **3.3 Millwork**

The millwork industry is a leading supplier to both the new residential construction market and the residential repair and remodeling market. Millwork consists of wooden components such as windows, doors, moldings, and trim lumber. Wooden doors comprise the largest segment of the market, at thirty percent of output, followed closely by wooden windows at twenty-six percent. Wood moldings represent a fourteen percent segment. The remaining thirty percent of output is classified as “other output,” and includes products such as wooden stairs, wood blinds, shutters, and exterior millwork such as porch columns.<sup>11</sup>

---

<sup>11</sup> “Millwork Industry: Profile and Trends,” *Construction Review*, September/October, 1989.



**Figure 3-3: Millwork Product Breakdown**

In remodeling, windows are often custom made to fit an existing rough opening, and some producers cater to such custom markets. However, since most of the largest window manufacturers each offer several thousand “standard” variations in size and shape,<sup>12</sup> it is likely that an existing configuration will satisfy most needs, especially in new construction.

### 3.3.1 Size

In 1989, the millwork industry produced 9.8 billion dollars worth of products. Table 3-6 shows a breakdown of shipments by product type for the years 1972 through 1989 in millions of current dollars.<sup>13</sup> Note that 1982 was a poor year for millwork, as it was for all construction. However, the 1980's after 1982 marked a period of sustained growth, with shipments increasing ninety percent in constant dollars between 1982 and 1988.

---

<sup>12</sup> Sanchez, Ron. “The Shifting Locus of Value-Added in Housing: The Onsite-to-Offsite Impetus for Innovation,” Unpublished Report, MIT Center for Construction Research and Education.

<sup>13</sup> Auerbach, Mitchel I., “Millwork Industry: Profile and Trends,” *Construction Review*, September/October, 1989.

Year	Total	Doors	Windows	Moldings	Other
1972	2229.7	816.2	391.7	544.0	477.8
1973	2566.8	1013.7	440.8	581.0	531.0
1974	2203.4	836.2	458.2	497.7	411.3
1975	2231.3	852.2	522.4	458.1	398.6
1976	2860.3	1049.5	740.3	647.1	423.4
1977	3693.4	1349.1	806.8	729.2	808.3
1978	4390.0	1641.2	963.5	985.1	800.2
1979	4525.5	1637.7	998.6	954.1	935.1
1980	4115.9	1524.1	844.0	852.8	895.0
1981	4325.5	1500.4	928.0	865.7	1031.4
1982	3988.4	1380.9	817.9	693.3	1096.3
1983	5301.1	1756.0	1255.2	1004.6	1285.3
1984	6133.9	2174.3	1369.7	1117.5	1472.4
1985	6368.4	2270.7	1524.4	1084.5	1488.8
1986	7232.3	2532.9	1803.2	1153.5	1742.7
1987	8737.0	2661.9	2299.6	1261.6	2514.0
1988	9308.3	2835.9	2449.9	1334.1	2688.4
1989	9839.1	2997.6	2589.6	1357.3	2894.5

**Table 3-6: Millwork Industry Shipments, Millions of Current Dollars**

### 3.3.2 Firms

According to King,<sup>14</sup> the window manufacturing industry was extremely fragmented until 1970. Since then, some firms have grown in size. Marvin Windows has reportedly doubled in size every five years since 1970. During the 1980's the window manufacturing industry grew dramatically and many companies changed from small craft businesses into large semi-automated manufacturers. King reports that its growth has "far surpassed the growth of metal windows and other millwork." These facts may be true. However, it is also true that the fraction of all millwork establishments with twenty or more employees remained constant at about one-third during the second half of the 1980's, the growth period. Harris writes that the window industry is still fragmented, with the top three producers combining for only twenty-six percent of the market (Andersen - fifteen percent, Pella - six percent, and Marvin - five percent).<sup>15</sup>

Despite the presence of some large, powerful firms, the millwork industry has been easy to enter and exit. It seems that small craft producers and large firms are able to coexist in the market. Most millwork firms are still relatively small, with an average of twenty-eight production workers in 1989, or roughly sixty-four percent of the average for all

---

<sup>14</sup> King, Andrew and Stephan Schrader, "Technical Information Transfer within the Window Industry," Unpublished Year End Project Report for 1989, MIT.

<sup>15</sup>Harris, John, "The Window Frame as Fashion Item," *Forbes*, April 30, 1990.

manufacturing firms. Auerbach<sup>16</sup> reports that in 1987, seventy-two percent of establishments had twenty or fewer employees, and less than five percent had one hundred or more employees. Production workers tend to be skilled and in 1989 received wages equal to ninety-seven percent of the average for all industries.

### 3.3.3 Cost of Production

Table 3-7 shows an input-output table for the millwork industry in 1982. As would be expected, labor and lumber are the most significant inputs. However, profit seems to be unexpectedly low.

Commodity Used in Production	% Value
Compensation of employees	29.1%
Sawmills and planing mills, general	21.5%
Profit type income, net interest, and capital consumption allowances	8.8%
Wholesale trade	8.3%
Veneer and plywood	3.4%
Hardware, not elsewhere classified	2.8%
Screw machine products & bolts, nuts, rivets, & washers	2.6%
Wood products, not elsewhere classified	2.3%
Advertising	1.8%
Motor freight transportation and warehousing	1.7%
Metal stampings, not elsewhere classified	1.5%
Glass and glass products, except containers	1.5%
Railroads and related services	1.2%
Electric services, (utilities)	1.1%
Paints and allied products	1.0%

**Table 3-7: Use Table for Millwork**

### 3.3.4 Potential for Improvement

The millwork industry is an attractive target for the adoption of flexible manufacturing systems for several reasons. In the millwork industry, value added represents thirty-eight percent of total cost, while materials contribute thirty-seven percent, outside services fourteen percent, and other costs eleven percent. Since value added is significant, there may be substantial opportunities for improving production efficiencies. Also, many firms have the size and resources needed to develop and implement new technologies. Implementation of technological changes in production should be relatively easy compared to other suppliers, since the industry tends to have skilled employees. In addition, the industry is somewhat shielded from the investment risk associated with housing's

---

<sup>16</sup>Auerbach, Mitchel I., "Millwork Industry: Profile and Trends," *Construction Review*, September/October, 1989.

cyclical of demand, since the repair and remodeling market (which is roughly counter cyclical to new housing starts) uses a substantial portion of output.

Marvin Windows is an interesting case for further study. They have been growing rapidly while producing customized, made to order windows. They carry no inventory of finished windows. According to Harris,<sup>17</sup> Marvin delivers completed windows in about three weeks, at a cost to the builder of roughly the same as a comparable stock window from Andersen. In addition, Harris estimated net margins at nine percent, roughly one to two percent higher than most competitors. The company's retailers typically operate with a fifteen to twenty percent profit margin.

Marvin's adoption of flexible, made to order production will likely allow it to continue to grow and may force small, technologically inferior craft producers out of the industry. The question is whether or not Marvin's success is attributable to its production technology, and if so, how it can be duplicated throughout the industry and in other supplying industries. A case study of Marvin Windows was performed in conjunction with this thesis. Chapter Seven presents the findings.

### **3.4 Wood Kitchen Cabinets**

Wood kitchen cabinet production includes production of custom and stock cabinets for kitchens as well as for bathroom vanities. Stock cabinets are typically available in a range of sizes in three inch increments. However, some firms are beginning to use computer controlled cutters and can economically make cabinets of any size.<sup>18</sup>

Table 3-5 shows the relative share of each type of product for 1987. Custom products represent a full thirty percent of the output.<sup>19</sup> However, the table is slightly deceptive since over one quarter of output is unclassified. *Kitchen & Bath Business* reported another distribution of market shares, as shown in Table 3-6.<sup>20</sup> According to this data, custom and semi-custom output each represented roughly twenty percent of the market.

---

<sup>17</sup>Harris, John, "The Window Frame as Fashion Item," *Forbes*, April 30, 1990.

<sup>18</sup>Personal communication with William D. Wester, Director of Marketing and Communications, Kitchen Cabinet Manufacturers Association, Reston, VA, on 7-20-94.

<sup>19</sup>Darnay, Arsen J. Editor., *Manufacturing USA: Industry Analyses, Statistics, and Leading Companies*, Volume 1, SIC 2011-3299. 1993.

<sup>20</sup>"Who's Who in Kitchen Cabinets," *Kitchen & Bath Business*, July, 1994.

Product	% Share
Stock wood kitchen cabinets and cabinetwork	38%
Custom wood kitchen cabinets and cabinetwork	26%
Stock vanities and other cabinetwork	6%
Custom vanities and other cabinetwork	4%
Wood kitchen cabinets & Vanities, not specified by kind	26%

**Table 3-5: Wood Kitchen Cabinet Product Distribution**

Product	% Share, 1989	% Share, 1993
Stock Cabinets	58.0%	61.1%
Semi-Custom Cabinets	16.0%	19.9%
Custom Cabinets	26.0%	19.0%

**Table 3-6: Cabinet Product Distribution**

In 1993, the average factory selling price of a stock twenty-four inch base cabinet was ninety-nine dollars. Semi-custom and custom cabinets of the same size sold for 145 dollars and 209 dollars, respectively.<sup>21</sup> This demonstrates the high value of differentiation in the cabinet market.

### 3.4.1 Size

The output of the wood kitchen cabinet industry grew steadily throughout the 1980's<sup>22</sup> and reached roughly 4.5 billion dollars in 1990. As shown in Figure 3-4, total demand for cabinets has been growing slightly, due to increasing remodeling sales, despite the falling demand from new construction.<sup>23</sup> Since people typically upgrade to higher quality, higher priced cabinets during a remodeling project, the remodeling market is especially important to cabinet makers.<sup>24</sup>

---

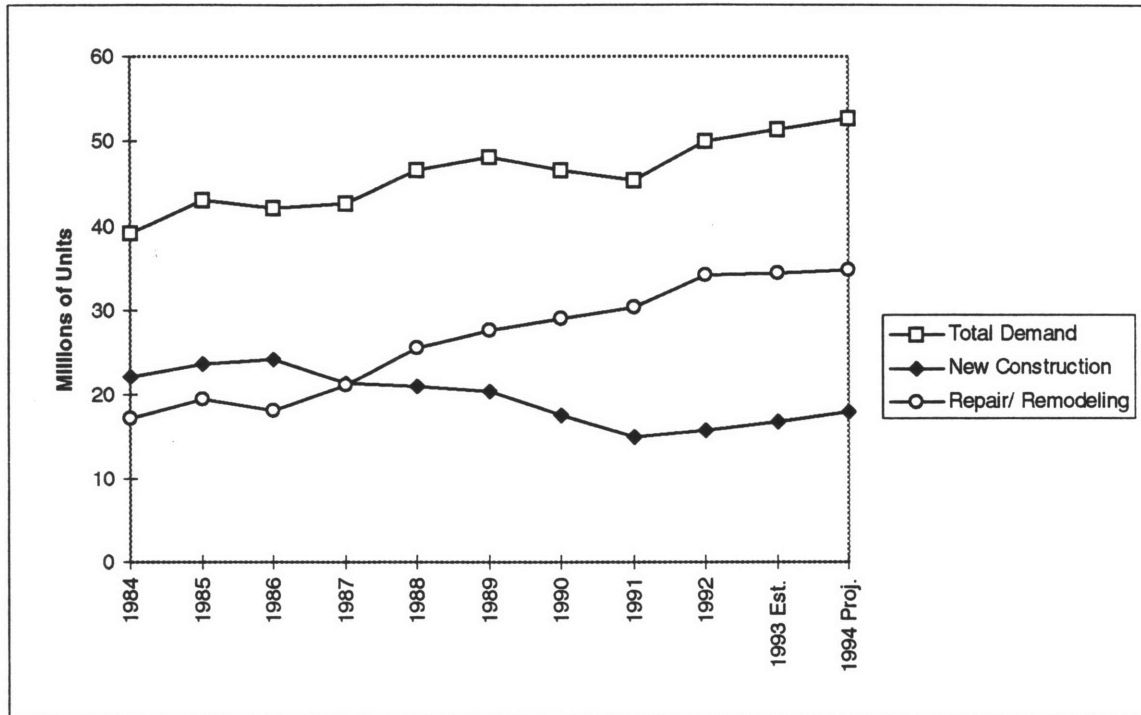
<sup>21</sup> "Who's Who in Kitchen Cabinets," *Kitchen & Bath Business*, July, 1994.

<sup>22</sup> Pitcher, C.B., "Construction Material Trends: Data from the Census and Survey of Manufactures," *Construction Review*, September/October, 1991.

<sup>23</sup> Source of data: Kitchen Cabinet Manufacturers Association, Reston, Va.

<sup>24</sup> Adams, Larry, and Rich Christianson, "The Streak Goes On," *Wood & Wood Products*, May, 1994.

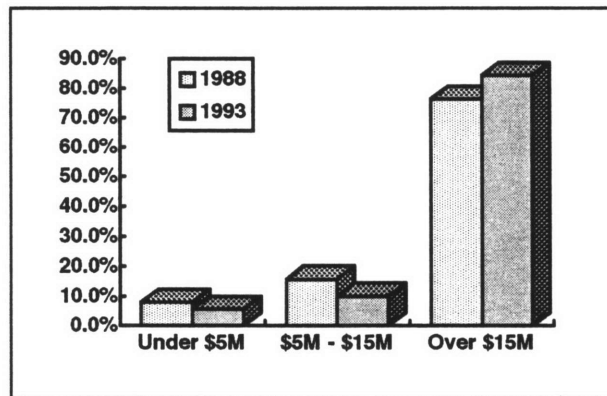




**Figure 3-4: Demand for Kitchen Cabinets**

### 3.4.2 Firms

Large companies dominate the market for cabinets. In this industry, firms with greater than fifteen million dollars in annual sales control eighty-five percent of the total market. As shown in Figure 3-5, market consolidation continued to occur between 1988 and 1993.<sup>25</sup>



**Figure 3-5: Market Share by Company Size**

<sup>25</sup>“Who’s Who in Kitchen Cabinets,” *Kitchen & Bath Business*, July, 1994.

The larger firms generally produce more stock cabinets, while smaller firms tend to focus on custom cabinets.<sup>26</sup> However, the average firm is small, with only sixteen production workers and nineteen total employees per establishment.

### 3.4.3 Cost of Production

As shown in Table 3-7, labor and material costs are the primary inputs to wood kitchen cabinet production. They contribute thirty-nine percent and 32.5 percent of the total cost, respectively. Other significant cost categories are outside services and other costs, at eleven percent each.

Commodity Used in Production	% Value
Compensation of employees	39.0%
Sawmills and planing mills, general	7.4%
Profit type income, net interest, and capital consumption allowances	6.6%
Wholesale trade	5.7%
Veneer and plywood	4.4%
Particleboard	3.8%
Hardwood dimension and flooring mills	3.4%
Hardware, not elsewhere classified	2.7%
Advertising	2.6%
Paints and allied products	2.3%
Wood products, not elsewhere classified	2.3%
Adhesives and sealants	2.1%
Motor freight transportation and warehousing	1.5%
Paperboard containers and boxes	1.4%
Metal stampings, not elsewhere classified	1.4%
Miscellaneous plastic products	1.3%
Electric services, (utilities)	1.2%
Other	11.0%

**Table 3-7: 1982 Use Table for Wood Kitchen Cabinets**

### 3.4.4 Potential for Improvement

Total value added represents a significant 45.6 percent of cost. Also, firms have made very limited capital investments in automation. Thus, a shift to increasing use of automated factor inputs could result in significant improvements.

While industry sales have been increasing, profit margins have fallen. Profits are being hurt by increasing material costs (lumber and particle board) and market forces that are driving

---

<sup>26</sup>Personal communication with William D. Wester, Director of marketing and Communications, Kitchen Cabinet Manufacturers Association, Reston, VA, on 7-20-94.

them to produce smaller and smaller batches of semi-custom or custom cabinets, rather than mass-producing stock cabinets.<sup>27</sup>

A recent survey of cabinet producers identified several problems that concerned them most. Of these, the top three were employee skills, government regulations, and foreign competition.<sup>28</sup> These concerns, coupled with the market forces driving increased variety, lead to the conclusion that production operations must look to improve. Computer integrated manufacturing technologies and flexible manufacturing systems will help solve these problems by:

- Decreasing the cost of variety;
- Decreasing the reliance on craft skills;
- Decreasing the turn-around time for custom orders;
- Increasing the competitiveness vis-à-vis foreign firms.

A major improvement occurred in wood kitchen cabinet production when it moved off-site. Today, specialized woodworking machines provide excellent quality, although production is still labor intensive. There are two possible ways to further improve production: by increasing the flexibility of currently automated tasks through design-manufacturing integration and by automating manual tasks.

Flexibility would be required of any automated system to satisfy the thirty percent of the market that demands custom cabinets. Design manufacturing integration will decrease the cost of flexibility and will streamline overhead and order processing operations. Thus, firms will be able to produce and sell the higher value custom cabinets at near stock cabinet prices. Also, producers could deal directly with builders, eliminating wholesale and retail trade markups and inventory carrying costs. This approach follows the lean production strategy, and does not necessarily require computer controlled equipment.

Automating manual tasks requires an analysis of the tradeoffs between labor and capital costs, assuming a particular demand profile and relevant production costs. It is not likely that the technology will result in additional quality improvements, unless new materials are simultaneously adopted, since current wood cutting technology produces accurate cuts, albeit with manual supervision. Thus, it is a relatively straightforward capital investment decision. However, if design and production are linked, the equipment can be computer controlled and will be much more flexible than if manual upstream operations are maintained.

---

<sup>27</sup>Adams, Larry, and Rich Christianson, "The Streak Goes On," *Wood & Wood Products*, May, 1994.

<sup>28</sup>Adams, Larry, and Rich Christianson, "The Streak Goes On," *Wood & Wood Products*, May, 1994.

## **3.5 Ready-Mixed Concrete**

Ready mixed concrete is the second largest contributor to material cost for housing. Ready mixed concrete, a made-to-order product, is manufactured with a remarkable amount of variety. It is available in a variety of strengths, with different aggregate types, and with numerous types of admixtures.

### **3.5.1 Size**

Shipments of ready-mixed concrete grew steadily throughout the mid-1980's from a low of 8.2 billion dollars in 1982 to a peak of 12.98 billion dollars in 1987. Every year between 1987 and 1991, shipments fell slightly (in nominal dollars) and totaled 12.68 billion dollars in 1991.

Residential construction uses more of the output of the ready-mixed concrete industry than any other industry sector. New single family residential construction uses twenty percent of total output, representing more than the amount used in office buildings, highways and street construction combined. The residential repairs and remodeling segment uses another eight percent of the output.

### **3.5.2 Firms**

There are just over five thousand firms producing ready mixed concrete in the United States. Firms tend to be small, with only about one-third of the average number of employees in the average manufacturing firm. However, production workers earned ten percent higher than average wages. Capital investment per employee is much higher than the other housing industry suppliers that were studied and totaled 491 million dollars in 1989 (just under 100,000 dollars per firm). However, it is still four percent lower than the average for all manufacturers. Since the early 1980's, there has been an upward trend in capital investment, as firms have invested in increasingly automated facilities.

### **3.5.3 Cost of Production**

Ready-mixed concrete plants are essentially flexible manufacturing systems. Batch plants are usually automated, and bulk material handling is mechanized. Actually, bulk material handling technology has advanced to the level that it can be totally automated. One company in California recently installed a fully automated aggregate loading system based on the banking industry's automated teller machine concept. Any time of the day or night, a driver can pull a truck under the loading facility, insert a special card, and wait about one minute while the system automatically dispenses the load.<sup>29</sup> The system has resulted in increased loading accuracy and decreased loading time.

---

<sup>29</sup> "Nova Award Winners Not the Same Old Thing," *Civil Engineering*, July, 1994, pp. 19-21.

<b>Commodity Used in Production</b>	<b>% Value</b>
Compensation of employees	24.3%
Cement, hydraulic	22.9%
Profit type income, net interest, and capital consumption allowances	10.4%
Sand and gravel	10.1%
Motor freight transportation and warehousing	7.8%
Dimension, crushed, and broken stone	3.1%
Wholesale trade	2.4%
Railroads and related services	2.0%
Petroleum refining	1.8%
Advertising	1.7%
Indirect business taxes	1.4%
Gypsum products	1.2%
Other	10.9%

**Table 3-8: 1982 Use Table for Ready-Mixed Concrete**

### 3.5.4 Potential for Improvement

The ready mixed concrete industry will continue to increase the level of automation of existing plants and will continue to replace older, outdated facilities with more efficient automated plants. As shown in Table 3-9, the Bureau of Labor Statistics projects changes in employment levels in accordance with these trends. Projected employment will increase for truck drivers, mechanics, and sales people, but it will fall sharply for skilled workers and office staff, as automation proliferates.

<b>Occupation</b>	<b>% of Total, 1990</b>	<b>Estimated % Growth or Decline by 2005</b>
Truck drivers, light and heavy	29.4	13.1
Helpers, laborers, & material movers, hand	6.2	-5.3
Supervisors of blue collar workers	4.5	2.3
General managers & top executives	4.0	-2.3
Sales and related workers	3.0	27.3
Industrial truck & tractor operators	2.8	1.7
Bus & truck mechanics & diesel engine specialists	2.6	9.7
Assemblers and fabricators, n.e.c.	2.5	-20.4
Bookkeeping, accounting, & auditing clerks	2.4	-22.4

**Table 3-9: Occupations Employed in SIC 327 - Concrete, Gypsum, & Plaster**

Clearly, the potential for improvement in the ready mixed concrete industry is lower than for the other industries studied, since it has already adopted flexible, efficient production technologies. The proliferation of the technologies throughout the industry will be the greatest source of improvement.

### **3.6 Conclusions**

Flexible manufacturing systems and advanced manufacturing technologies are no “magic bullet” for housing. However, manufacturers of pre-assembled components will benefit from the production technology. By combining the technologies with an appropriate information technology strategy, suppliers can link directly to builders, capture higher market share, and realize higher profit margins. In addition, they can achieve an ancillary benefit of the technology: the elimination of retail trade costs.

One supplying industry, ready-mixed concrete, has adopted flexible manufacturing and automation. The industry invests in capital goods at a rate comparable to other manufacturers, production is flexible and efficient, and workers earn higher than average wages.

Prefabricated wood building manufacturers could also adopt the technology with the goal of increasing efficiency and flexibility to the extent that they can become a more formidable substitute product for site-built construction. Increasing the productivity of the factory workers by twenty percent would decrease overall production cost by five percent, making the product more competitive. This five percent reduction in superstructure cost would represent roughly a two percent decrease in the cost of housing (assuming that the superstructure, including its finishes, represents eighty percent of construction cost).

## 4. Off-site Production Processes and Technologies

This Chapter presents a survey of the technologies and processes used off-site to produce pre-assembled materials, components, and subassemblies, including: prefabricated wood buildings, structural components, millwork, and wood kitchen cabinets.

### 4.1 Introduction

Three classes of products are made off-site: materials, pre-assembled components for housing, and entire homes or home packages. Each class of products has different production requirements. Thus, manufacturers utilize different production technologies. Specifically, as the class of products progresses from materials to components to homes, the flexibility requirements increase while the production volumes and batch sizes decrease.

Homebuilding materials include mass produced items such as gypsum wallboard, dimensional lumber, plywood, nails, asphalt shingles, vinyl siding, and others too numerous to mention. Mass produced materials, typically made in highly automated plants, are available in only a few standard sizes. However, the parts are easily modified (cut to fit, for example), resulting in sufficient flexibility but requiring additional on-site operations. Since the need for production flexibility is small for mass produced components, they are excluded from further discussion in this thesis.

As described below, pre-assembled components such as windows, doors, and kitchen cabinets are made in factories that are less automated than those producing materials. In contrast to materials, components are typically produced in many varieties and usually only require a relatively simple on-site installation. Off-site produced components and materials have greatly increased the speed of on-site construction. In addition, the quality of the components produced off-site is typically much higher than those produced on-site.

As described in Section 3.2, the off-site production of homes can be classified into four sub-categories: precut, panelized, modular, and HUD code. Moreover, “panelized production” refers to either the production of a panelized home package or simply to the production of structural wall panels and non-loadbearing partitions to be installed in an otherwise site-built home. For this thesis, the former will be referred to as a panelized home, and the latter will be referred to as a wall panel component.

The following off-site production facilities were visited:

- Three modular home manufacturing plants were toured. These tours provided insight into the technologies used in the off-site production of homes.
- One factory that produced both panelized home packages and wall panel components was toured. This tour provided a great deal of insight into the production of home packages and components.

- One manufacturing facility for wall panel components and trusses was toured, adding to the data on the production of components.
- A detailed case study was performed at Marvin Windows, a major supplier of millwork. This example illustrated component production and is described in Chapter Seven.

Off-site production operations and the technologies utilized in off-site production are described below. Section 4.2 describes off-site housing production, Section 4.3 describes production of wall panels and trusses, Section 4.4 describes millwork production and Section 4.5 describes wood cabinet production. The descriptions are based on the facility tours as well as information gathered from company literature and other published sources.

It is noteworthy that off-site technologies and methods for prefabricated *home* construction closely resemble those developed on the site. This should be expected, since the majority of prefabricated homebuilders have construction backgrounds. In contrast, most material suppliers have backgrounds in manufacturing, and therefore are much more likely to adopt production technologies used in other manufacturing industries. Manufacturers of components such as wall panels, trusses, and pre-assembled utility cores bridge the gap between traditional manufacturing and traditional construction practices, and often use production technologies specifically designed for assembly of the component.

## **4.2 Prefabricated Wood Building Production**

Methods used for the off-site production of prefabricated wood buildings closely resemble those utilized on-site for two reasons: the materials and components used in both types of production are essentially identical and the majority of off-site homebuilders have construction backgrounds. Thus, in the prefabricated wood building industry and in the mobile home industry, production technology is dominated by three classes of equipment: 1.) powered hand tools; 2.) specialized stationary equipment; and 3.) conveyances. Following an overview of typical off-site home production operations and a description of the operations at the three toured facilities, each of these classes of equipment is described in detail.

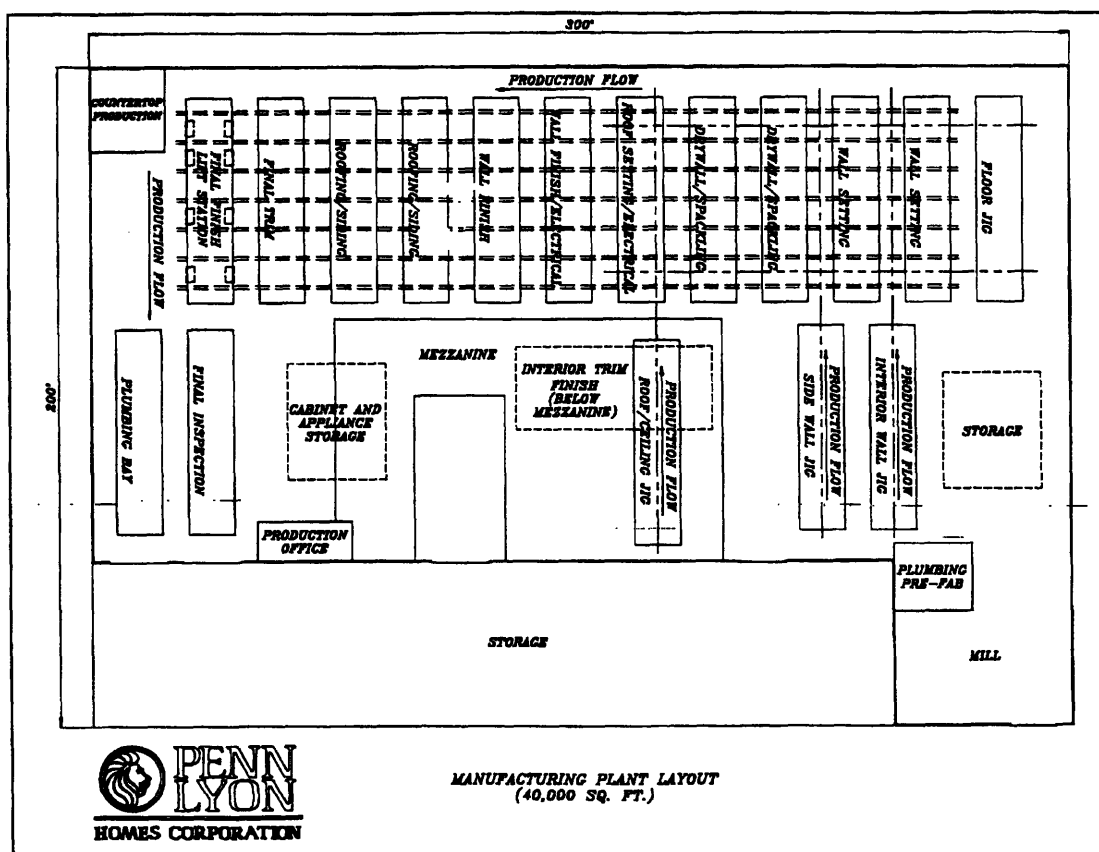
### **4.2.1 Off-Site Home Production Operations**

Figure 4-1 depicts the plant layout for Penn Lyon Homes, was published in the *Automated Builder Dictionary/Encyclopedia of Industrialized Housing* as a typical example of modular manufacturing. As shown in Figure 4-1, production flow follows an assembly line.

At the first production station, the floor assembly is manufactured in a three-step process. In step one, the floor framing members are assembled; in step two, the assembly is squared on a jig; in step three, the floor sheathing is installed. At stations two and three, pre-



assembled interior and exterior walls are erected on the floor. The pre-assembled walls are squared with jigs on secondary assembly lines. Rough plumbing and electrical appliances can be pre-assembled into the walls while on these “feeder” lines. In the next two stations, drywall is installed, spackled, and sanded. Next, the roof structure and/or ceiling, which is also pre-assembled on a feeder line, is installed on the module. In the next two stations, wall finishes are applied and electrical installations are completed. Roofing materials and exterior siding are installed in the next two stations and the interior and exterior trim is added. At the final station, any unfinished operations are completed and the unit is lifted off the rail line to be transported. It stops briefly in the plumbing bay, where plumbing fixtures are installed. Once the module is inspected and wrapped for shipping, it is ready to go (roughly, ninety percent complete).



**Figure 4-1: Penn Lyon Homes Modular Plant Layout**

The plant layout in Figure 4-1 is similar to the layout of the modular plants that were visited. In these plants, house modules flow along a main assembly line. The house modules rest on rails. They either continuously advance along the line or flow is indexed from station to station (all units advance together at fixed intervals of time). Likewise, it is typical for subassemblies to be made on feeder lines or in other parts of the plant. Modular plants usually maintain large inventories since they must maintain so many different parts. Due to the costs associated with maintaining such large inventories, modular producers typically limit flexibility in terms of part variety.

Overall, the production flow and precedence relationships between activities are similar to those found on-site and the technologies used in production differ only slightly. Off-site, there is greater use of powered hand tools, there are jigs to aid in the assembly and squaring of framing, and there is a means for conveying modules and subassemblies through the plant.

Although the typical prefabricated homebuilder builds several designs, the greatest source of variation (which is difficult for machines to detect and thus compensate for) is the same as that found on-site — the materials themselves. This variation has resulted from years of evolution of construction materials and methods centered on manual labor processes. For example, since it is easier to consistently provide quality factory produced moldings than to consistently produce quality connections in manually applied drywall, moldings are used on the floor to wall intersections to cover variations and imperfections. Innovations in this area have concentrated on producing new decorative moldings and plastic moldings, and have ignored the possibility of eliminating the piece completely by the production of precise joints.

#### **4.2.2 Operations at Regional Building Systems Modular Housing Facility**

Regional Building Systems (RBS) is a spin-off company of the Ryland Group formed when two vice-presidents of Ryland bought what was then called Ryland Building Systems. RBS operates a modular plant in Northeast, Maryland and a panelized housing plant in Fredericksburg, Virginia. Virtually all operations went unchanged throughout the transition, and RBS continues to produce manufactured homes exclusively for the Ryland Group.

Similar to on-site assembly, each house is built from an individual set of construction drawings. The plant produced roughly sixty different plans (single and multi-family), with about twenty variations per plan. The homes varied from eight hundred fifty to three thousand square feet of living space and are between ninety and ninety-five percent complete when shipped from the factory.

Workers used several types of production equipment at the plant. Radial arm saws were used to cut the framing members. Workers used pneumatic staplers and nailers to assemble framing members, to attach sheathing and roofing materials, and for other connections. Infrared heaters were used to speed the curing of drywall joint compound. A steel track transported the modules within the plant, and overhead cranes were used for heavy lifting of subassemblies. Despite the presence of overhead cranes, material handling was often performed by hand and with fork lifts.

One innovative product, “Foam Seal,” was used to connect the drywall to the ceiling. Foam Seal is a spray-applied expansive foam material that hardens when dry. The product is an adhesive and eliminates the nailing and gluing traditionally used. The foam is produced from two toxic chemicals which form a non-toxic compound when combined. Although the process improves productivity, the product is reportedly too costly to be used for all walls. It is used on ceilings because of the increased difficulty of nailing and

gluing them. It is unlikely that such a system would be applicable to on-site use, due to the expensive equipment required. However, it illustrates an example where new technologies can be economically used in factory production, where volumes are typically higher and equipment mobility is not required.

The plant manager at RBS believes that the two greatest barriers to the use of automated production equipment are the short term investment outlook of firms in the industry and the rapid product changes caused by an industry trend toward increased customization. While he admits that consistency and quality would probably increase with automated equipment, he feels that the technology would fail due to the low-tech culture of the industry.

#### **4.2.3 Operations at Nanticoke Homes Modular Housing Facility**

Unlike RBS, whose products are sold exclusively through a central builder (Ryland Homes), Nanticoke Homes primarily retails its product to the end user, private homeowners. All homes are pre-sold and customized by the buyer, with financing also prearranged. In August 1991, Nanticoke Homes was operating at forty percent of capacity, producing ten homes per week. The homes are eighty-five percent complete upon shipment from the factory, but turnkey packages are also available for customers. Nanticoke uses quality and flexibility to compete in its market against site builders, not against other modular producers. They stress the use of top quality materials and workmanship, with satisfaction guaranteed. Although the use of one of several standard plans is strongly encouraged, they will build any house plan provided to them.

Similar to other manufacturers, all homes are manufactured from construction drawings. Production time in the factory is six days, but it takes an average of *thirty-four* working days between the placement of an order and the first production day in the factory. Nanticoke uses a computerized, text-based event tracking system to track orders through the thirty-four day period. During this time, the plans are drafted and submitted for final approval and colors are picked. Roughly fifty percent of the drafting is performed on a CAD system, with fifty percent done manually. However, the drafting and event tracking systems are completely separate, and no data from either system is electronically transferred to the production phase.

Production is similar to site-built operations, except that all framing lumber is pre-cut with manually operated radial arm saws and workers utilize pneumatically powered nailers and staplers. Workers handle most materials manually, but fork lifts and overhead cranes are used for moving bulk materials.

One official at Nanticoke feels that the greatest barrier for the use of advanced technology in the manufactured housing industry is the lack of skilled workers required to operate and maintain such systems. He reported an inability of his personnel to use the computers and technology that the firm currently owns to its capacity, and see further expenditures as fruitless until they are able to capitalize on existing capabilities.

#### 4.2.4 Operations at North American Homes Modular Housing Facility

The North American Housing Corporation differs from the other two firms described in that its principals were uncooperative in this study. They cited a corporate policy of complete secrecy. All information was obtained through observations and questions during a brief plant tour.

The North American Housing Corporation produces modular homes in a ninety thousand square foot plant in Point of Rocks, Maryland. In August 1991, the plant was operating at roughly two-thirds capacity, producing ten “boxes” per day (a box refers to a segment of a modular house). The firm competes on the basis of price, selling most of the homes to private builders. There is some design flexibility, but all designs must be derived from a set of basic plans and predetermined options.

Operations were very similar to the other modular plants visited, with construction being performed as it is on-site. It is not known whether or not design and drafting are computerized, although separate drawings are prepared for each house, as in other plants. Very little use of assembly equipment was observed, except for staple and nail guns. It was reported that framing lumber was precut using large saws. However, this was not visually confirmed during the tour.

#### 4.2.5 Powered Hand Tools

Powered hand tools include nailers, staplers, screw guns and glue guns that are powered pneumatically or electrically. There are numerous manufacturers of these tools. They are affordable and used extensively throughout the industry. In fact, the plant manager at Regional Building Systems stated that he believes the development of pneumatic staple and nail guns was one of the two greatest innovations in factory produced housing in the last thirty-five years — the other one was the development of wood trusses.

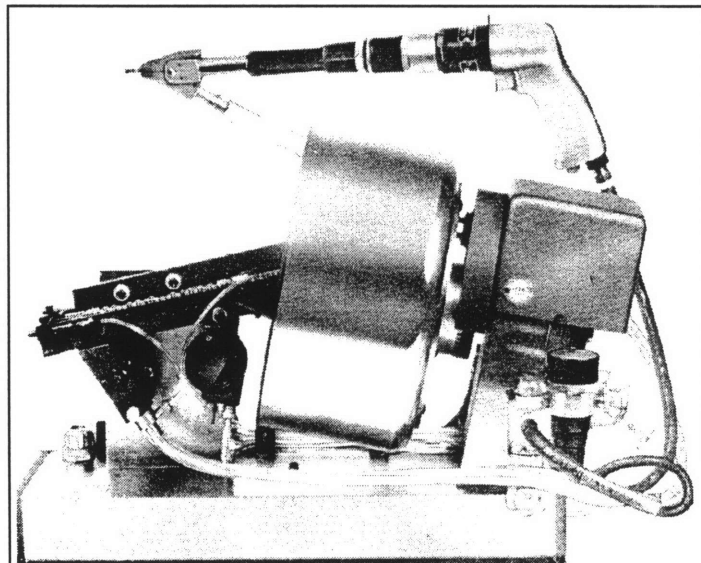
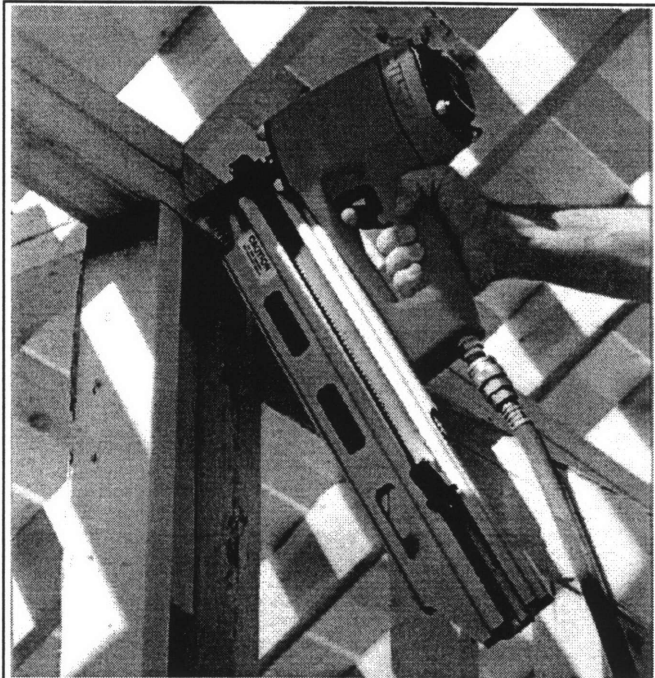


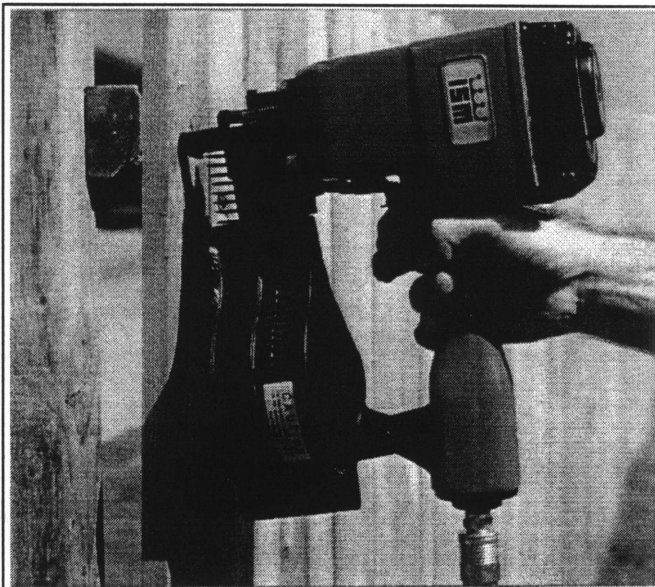
Figure 4-2: Screwdriver With Vibratory Feeder

The matching of tool and task depends primarily on the type of fastener and the range of sizes required. Typically, staples are the least expensive type of fastener but have the lowest strength. Nails are commonly more costly than staples and have moderate strength. Screws are the most costly but have the highest strength and are more secure (they resist nail pops, which effectively reduce quality). Each tool is usually capable of accommodating a limited range of sizes of a particular fastener type. For example, a Hilti Model RFC-134B coil nailer is capable of using five sizes of round head roofing nails between 0.875 and 1.75 inches long; the Hilti Model SN-114B Narrow Crown Stapler System is compatible with seven sizes of narrow crown staples between 0.5 and 1.25 inches long. In other words, there are a large variety of nailers, staplers, and screw guns. Each has limited task flexibility, due to the differing mechanical requirements of different fastening tasks.

Staples are typically sold in strips, while nails and screws are available in three configurations: strips, coils, and loose. Loose nails and screws are less expensive but their use requires an additional piece of equipment, a vibratory feeder, which continuously replenishes the tool with fasteners. An example of a screw gun with a vibratory feeder is presented in Figure 4-2. Figure 4-3 and Figure 4-4 present examples of a strip nailer and a coil nailer. A vibratory feeder is a fixed piece of equipment with a relatively expensive initial cost but with savings accruing from reduced (variable) fastener cost. Therefore it is applicable to higher volume production in a single location.



**Figure 4-3: Pneumatic Strip Nailer**



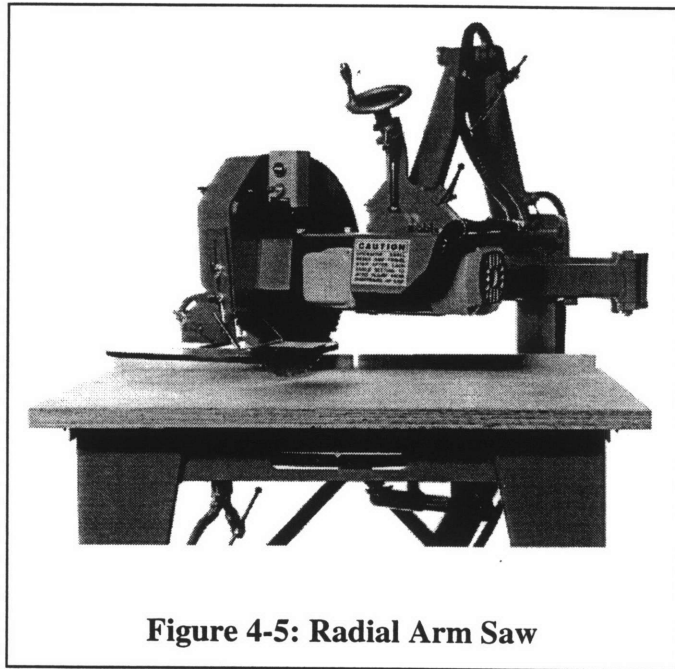
**Figure 4-4: Pneumatic Coil Nailer**

#### 4.2.6 Specialized Stationary Equipment

Stationary equipment used in modular home production includes framing tables and lumber processing machinery such as radial arm saws. Radial arm saws, as shown in Figure 4-5, are powered saws used to cut framing members to specified lengths and angles.

Framing tables are used in the assembly of wall panels. They typically have a mechanism for fixturing lumber that ensures that the resulting walls are square, and they may have a mechanism for connecting framing members together. They have the added benefit that they allow workers to

operate at waist level, rather than on the ground or overhead, as is common on-site. This typically increases worker productivity and decreases fatigue.



**Figure 4-5: Radial Arm Saw**

There are numerous types and manufacturers of wall panel framing tables. Typical examples are described in Section 4.3.3, Wall Panel Equipment. Due to lower production volumes, the types that are most likely to be utilized in modular home production are those that are less sophisticated than the equipment used in the production of panelized framing.

#### 4.2.7 Conveyances

Modular units and mobile home segments proceed along assembly lines, often being moved along tracks secured to the floor. The lines are often indexed, in that the entire line moves forward to the next station synchronously. Indexed lines result in smooth production flow, but as explained below, they establish limits on production flexibility.

Manufacturers keep assembly lines balanced in order to maintain efficiency. This means that operations at each station are designed to require the same amount of time. Variability in production upsets this balance, especially for indexed lines. Thus, only those changes that can be performed within the allotted time at each station are allowed. This philosophy is closely adhered to in mobile home manufacturing and most modular production. Most firms offer a range of models with certain limited options. Production schedules are devised in advance for each model and include variations for the permissible options. Although other deviations and options are not allowed in most cases, some producers do permit other customizations for an extra charge. Reportedly, consumer demand has forced producers to increase the amount of customization allowed. In fact, in response to the market demand and production realities, the U.S. Housing Corporation has set aside



twenty-five percent of the space in its new plant for special and customized orders, including “things like hardwood or ceramic tile floors and special bathrooms that slow down a normal production line.”<sup>1</sup> The degree to which demand for customization will upset production flow and efficiency is still to be seen. Any attempt to increase the flexibility of modular or mobile home production must address the issue of balanced lines.

### 4.3 Structural Components Production

This section describes the production systems, techniques, and technologies utilized in the production of panelized walls, wood floor trusses, and wood roof trusses. Trusses and wall panels are typically fabricated in batches, bound in like groups by job (see Figure 4-6), and shipped by truck to the site.

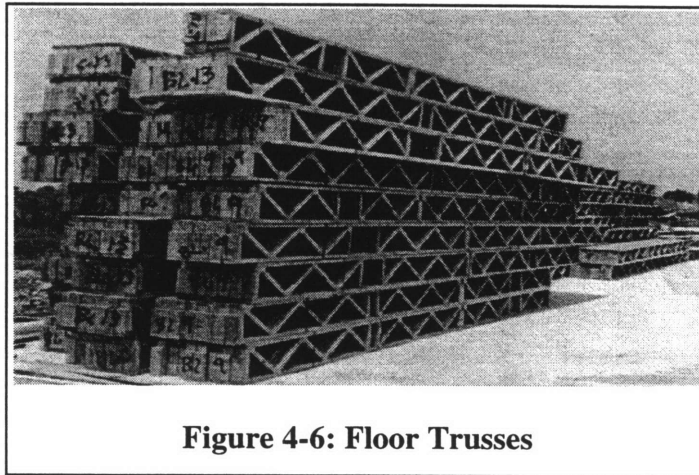


Figure 4-6: Floor Trusses

#### 4.3.1 Operations at Regional Building Systems Panelized Housing Facility

The Regional Building Systems facility at Fredericksburg, Virginia was very similar to the plant in Northeast, Maryland except that wall panel components were produced there in addition to home packages.

In August 1991, the RBS facility was operating at less than ten percent of capacity, producing twelve semi-detached, panelized houses per day for export to Israel. While very similar in overall design, each house contained variations in colors or accessories, and each was built from a unique set of construction drawings supplied by Ryland's central office in Columbia, Maryland. The panels consisted of framing, sheathing, and windows. No utilities systems or interior finishes were supplied.

Production equipment at the plant consisted of one table for panelized framing. It was equipped with a gang nailer for nailing the sheathing at twelve inches on center and a router for cutting a window opening in the sheathing after it had been applied. In addition, an older manually operated cutoff saw was used to precut the framing members in small batches.

RBS also shipped other materials and components with the wall panels, including: roof trusses (which were outsourced), roof sheathing, shingles, bathroom and kitchen

---

<sup>1</sup> “PA’s Newest Modular Plant Opens,” *Building Systems Builder*, July, 1994.

appliances, and a precut wooden porch. Material handling was performed manually and with forklifts. Shipping containers were loaded manually.

A plant official stated that he felt the biggest barrier to the increased use of complex production machinery was the extremely cyclical nature of demand, coupled with the availability of factory labor willing to work for eight dollars per hour. He admits that off-site production methods have been largely unchanged for twenty years. In addition, he stated that maintenance and repair of complex machinery would be prohibitively difficult with the machinist staff currently on hand at his plant. However, there appeared to be a general lack of understanding of advanced technology in the firm. For example, computers were only used for light record keeping and other office tasks, with only paper links to the plant floor.

#### **4.3.2 Operations at Shelter Systems, Inc. Panelized Housing Facility**

Shelter Systems is the largest producer of wooden building components in the United States, with a yearly volume of roughly sixty-five million dollars. In August 1991, they were operating at twenty-five percent of capacity and shipping components within a one hundred fifty mile radius. Shelter Systems differs from all of the other manufacturers visited in that they seek new technology and are currently developing automated systems in conjunction with an equipment supplier in Minnesota.

Production at Shelter Systems is highly mechanized with the use of multiple panel lines, an automated cutoff saw, and several setup stations. The heart of the system is the Auto-Omni cutoff saw, a “fully-automated” component cutting saw. Actually, the portion of the saw that is automated is the blade setup and the immediate feeding of material through the saw. Workers still must load material into the machine from a stack of lumber, sorting out twisted or warped pieces. In addition, they must unload the pieces and label them with a code used to identify the piece in the assembly process. However, an automated ink jet printing system is being developed to automate labeling.

Once the batches of lumber are cut, they proceed to either the panel lines or the truss assembly stations. The panel lines are similar to the one used by Regional Building Systems in the Fredericksburg plant, with pneumatic double nailers for nailing top and bottom plates into studs. The truss setup stations consist of specially modified, pneumatic presses and jiggling stands. In addition, work is currently underway to automate the truss setup operation.

An official at Shelter Systems said that he sees no barriers to automation and expects to be fully automated in a few years. He characterized the technology as “old” and “proven in other industries,” and feels that adoption by the housing industry is inevitable. Once they complete the automation of the truss setup operation, he foresees the integration of the Auto-Omni and the setup stations with automated material handling utilizing remote guided vehicles (RGV's).

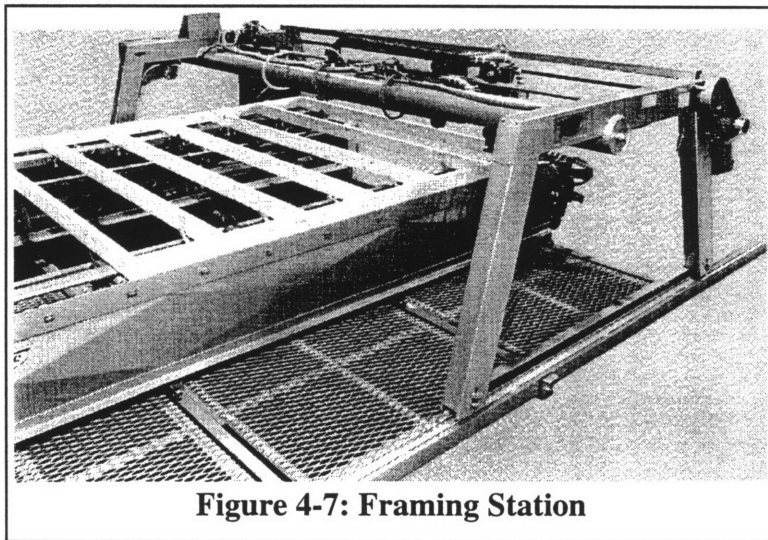


In addition to using high tech process automation, employees make extensive use of computers at Shelter Systems. They typically receive plans in AutoCAD format or manually drafted. Workers interpret the drawings and enter information into Trusstar, a truss design program by On-Line Data, and Aces, a panelizing program. The information is carried to the shop floor on floppy disk, where it provides the Auto-Omni saw with cut information. In addition to the design and production software, Shelter Systems has developed both a pricing model and a scheduling model to aid in operations management.

### 4.3.3 Wall Panel Equipment

Wall panel equipment is available in many types and styles from several equipment manufacturers. However, all machines provide roughly the same functionality: the squaring and assembly of a wall panel composed of studs, top and bottom plates, and other framing subassemblies such as headers for windows or other wall openings.

Figure 4-7 shows a wall framing machine produced under the Triad brand name of the Merrick Machine Company. Top and bottom plates are placed against the steel edges which run the length of the machine and ensure that segments remain square. Adjustable “stud locators” hold the studs in position. The bridge of the



**Figure 4-7: Framing Station**

machine, which can be computer controlled, then travels along the wall segment and pneumatic nailers end-nail the studs through the top and bottom plates. The machine can accommodate wall heights between eight and sixteen feet assembled from two-by-four to two-by-twelve studs. Stud locators (and thus studs) can be placed at twelve, sixteen, or twenty-four inches on center. Wall lengths are limited to the length of the machine, which can be built between twelve and eighty feet long.

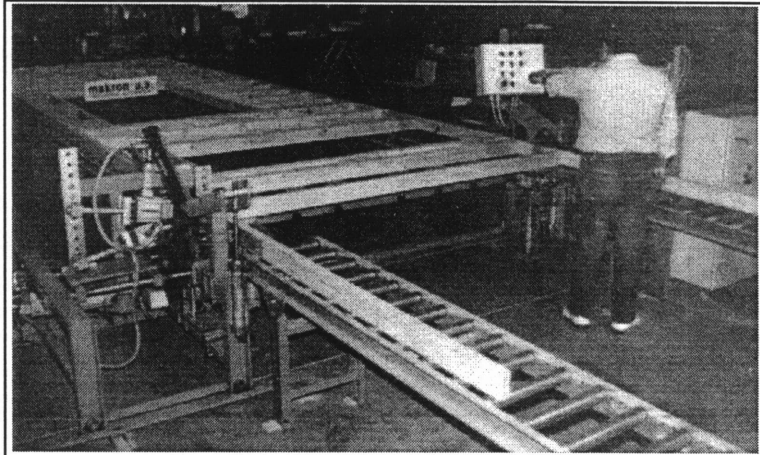
Figure 4-8 shows another type of wall framing equipment. The “Extruder,” produced by Makron, U.S., is a wall and floor framing machine. As the wall section passes through the machine, the top and bottom plates are guided along tracks and a worker inserts studs and/or pre-assembled header assemblies between the plates. As the section passes through the machine, hydraulic or pneumatic nailers in each end of the machine simultaneously insert multiple nails through the top and bottom plates into the studs and/or subassemblies. The use of a hydraulic nailer is unique and Makron claims it results in superior quality since the nails are consistently placed exactly at the right depth. Top and bottom plates are continuously spliced using another piece of equipment (not shown in Figure 4-8) so that wall segments of any length are possible. The extruder is capable of assembling wall (and

floor) segments with framing members as small as two-by-three's and as large as two-by-twelve's with wall heights (and floor widths) up to sixteen feet. The capacity of the machine is rather high, at six hundred lineal feet of wall per hour.

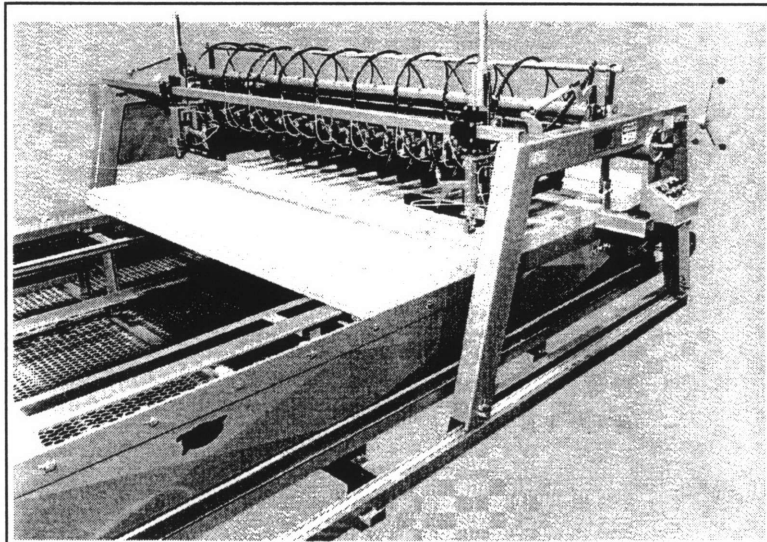
The Makron machines can receive data directly from a CAD system developed specifically for the machine by ComSoft, Inc., in

Trussville, Alabama. When orders are received, the design staff manually translates and enters the order into the ComSoft system, which represents the wall panels.<sup>2</sup> Again, a special purpose island of automation exists, with no integration to upstream information processes.

The two types of wall panel machines are similar in function. Both are special purpose machines that are capable of squaring and end-nailing walls of various sizes. One difference is that the extruder's nailing heads are stationary and the wall segments move through the machine, but for the Triad framing station, the wall segment is stationary and the nailing heads move along the length of the wall. The other difference is that the extruder is not capable of sheathing attachment (An extra piece of equipment is available from the manufacturer). Framing stations with movable bridges often also have sheathing nailers attached to the bridges.



**Figure 4-8: Wall Frame Extruder**

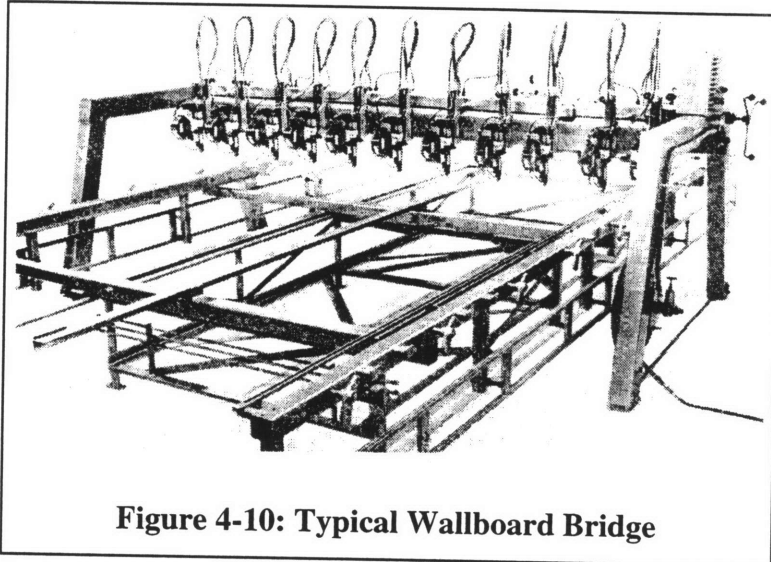


**Figure 4-9: Typical Sheathing Nailer**

---

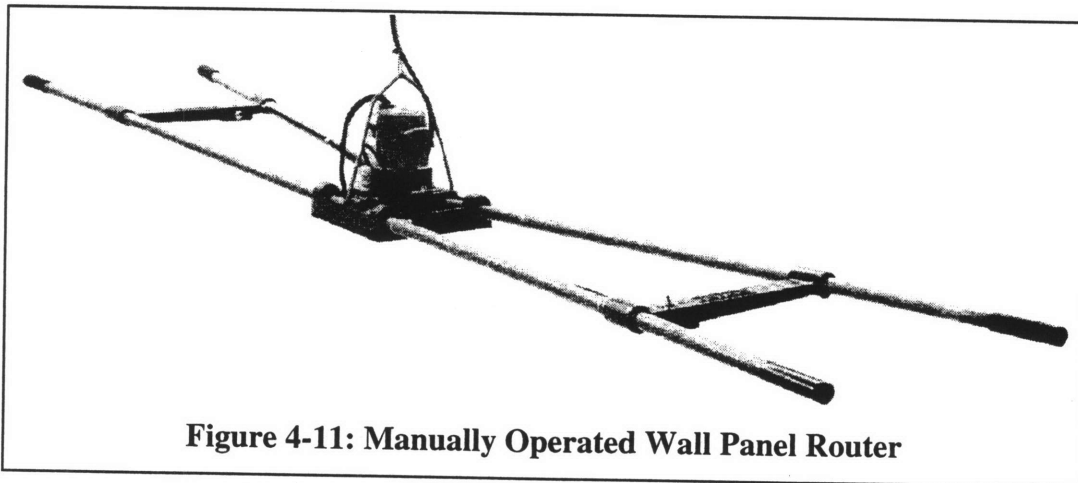
<sup>2</sup> Mullins, Michael A., "Innovative Home Producers Can Navigate New Technology Via Computer Modeling," *Automated Builder*, August, 1995.

Figure 4-9 shows a typical sheathing nailer. It consists of a movable bridge with several pneumatic nail guns positioned at the specified spacing. It can simultaneously insert several nails before indexing a given distance. Another similar piece of equipment is used to attach gypsum wallboard to the interior of closed-wall panels (Figure 4-10). The primary difference is the use of powered screw-guns instead of nailers. Sheathing and wallboard machines are typically manually setup and indexed, with powered attachment of the connectors.

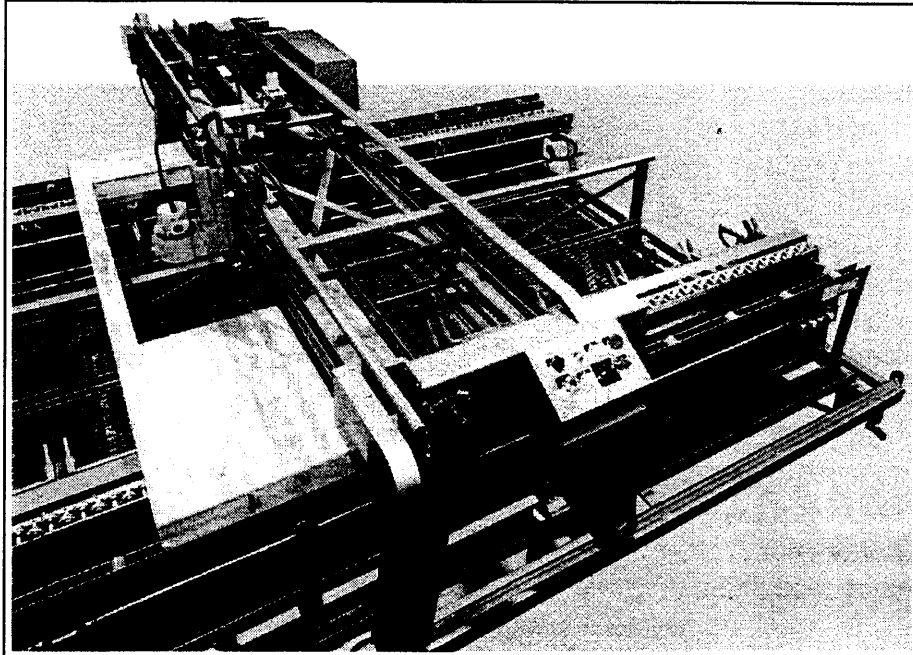


**Figure 4-10: Typical Wallboard Bridge**

Sheathing is typically attached as full sheets. Openings are then cut out as required with routers. Figure 4-11 shows an example of a manually operated wall panel router. Basically the tool consists of a router with two sets of long handles. Workers on both sides of a wall panel can guide the router head along the desired path. Figure 4-12 shows a mechanized variation of this machine in which the router is guided along rigid tracks connected to a wall panel machine.



**Figure 4-11: Manually Operated Wall Panel Router**

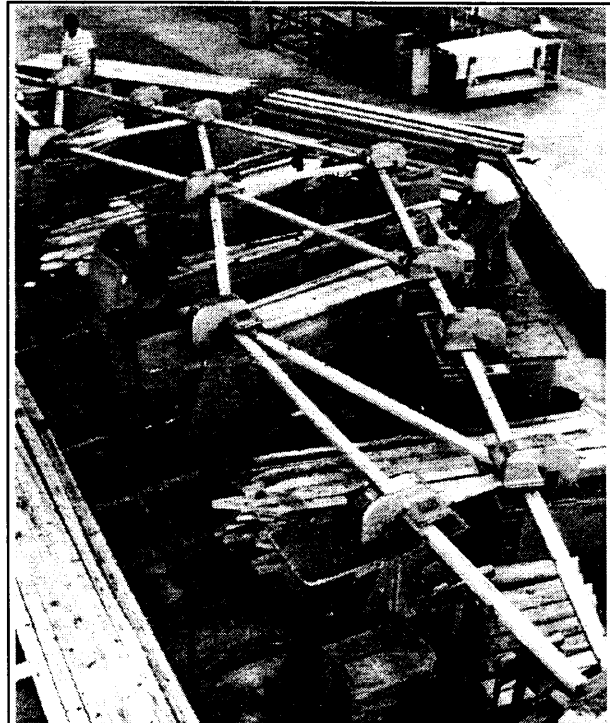


**Figure 4-12: Rail-Guided Sheathing Machine**

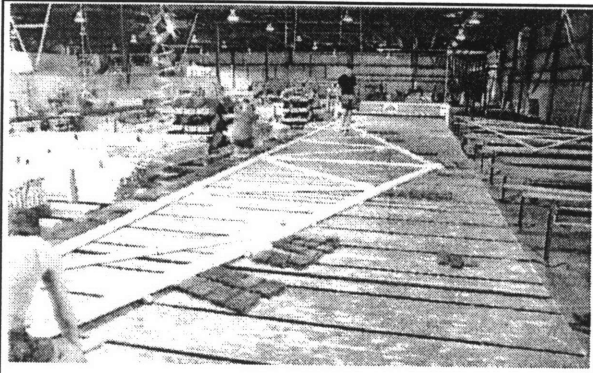
#### **4.3.4 Truss Assembly Technologies**

Truss assembly requires the completion of two tasks: the layout and fixturing of the truss members; and the attachment of the metal truss plates. Two methods for roof truss assembly have been developed. The first method, as shown in Figure 4-13, uses stands that contain fixtures that hold and support the wood members. Hydraulic presses that are built into the stands then secure the truss plates to the wood members by squeezing them. The second method, as shown in Figure 4-14, uses truss tables. Fixtures attached to the truss tables hold the wood members. A roller press then attaches the truss plates by rolling over them.

Floor trusses are typically fabricated with roller presses such as those shown in Figure 4-15 and Figure 4-16. They are available in several varieties.



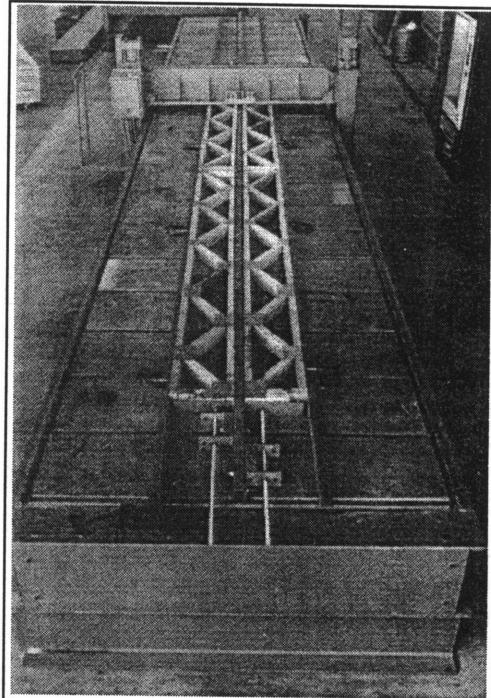
**Figure 4-13: Truss Stand Assembly**



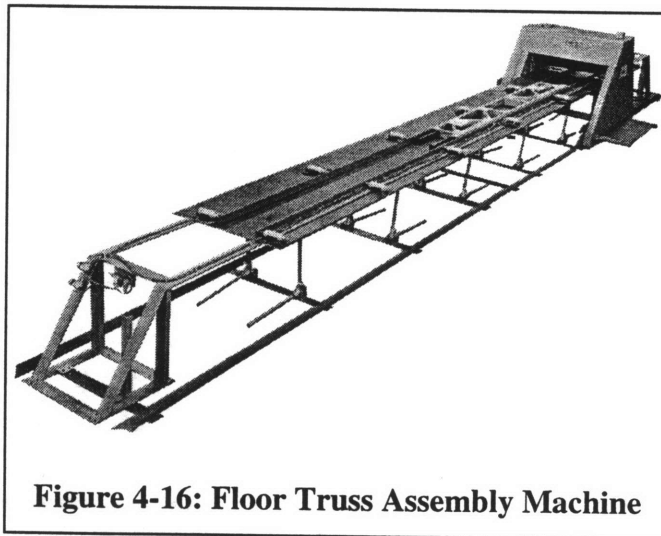
**Figure 4-14: Truss Table Assembly**

Advanced technologies are beginning to emerge in truss production. For example, the “Lasalign” laser truss projection system utilizes design information to aid in the setup of the fixturing of a truss table.<sup>3</sup> The system interprets CAD files and projects the intersections of the truss members on the truss table with one or more lasers, depending on the size of the trusses. The worker utilizes the outlines to guide the placement of the fixtures. The system has resulted in up to fifty percent decreases in setup times. Another firm has taken this approach one step further and has developed a truss table that automatically sets fixtures in response to the CAD input. The computer controlled setup makes flexible production and small batch sizes affordable.

Likewise, computers are being used in the production of the wood truss members. Multi-bladed saws such as the one shown in Figure 4-17 are used to cut both ends of a truss member simultaneously as it is fed through the saw. The computer controls the angles and positions of the blades, which can be adjusted for each piece, if necessary. Therefore, setup time is greatly reduced, increasing production flexibility. In some systems, an ink jet labels members as they exit



**Figure 4-15: Floor Truss Assembly Table**



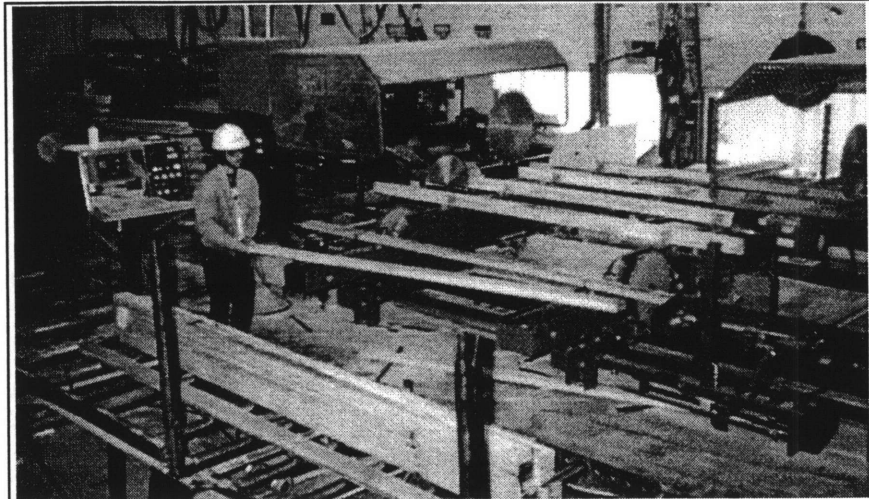
**Figure 4-16: Floor Truss Assembly Machine**

---

<sup>3</sup> “Lasalign Laser Projection System Can Cut Truss Setup Time by 50%,” Automated Builder, July, 1994, pp. 20-21.



the saw. Workers then manually transport them to the truss assembly table, which has been automatically setup (via computer controlled fixturing). Thus, setup time is decreased and flexibility increased for this task.



**Figure 4-17: Computer Controlled Multi-Bladed Saw**

## 4.4 Millwork

This section describes the spectrum of technologies used in the production of pre-assembled millwork components.

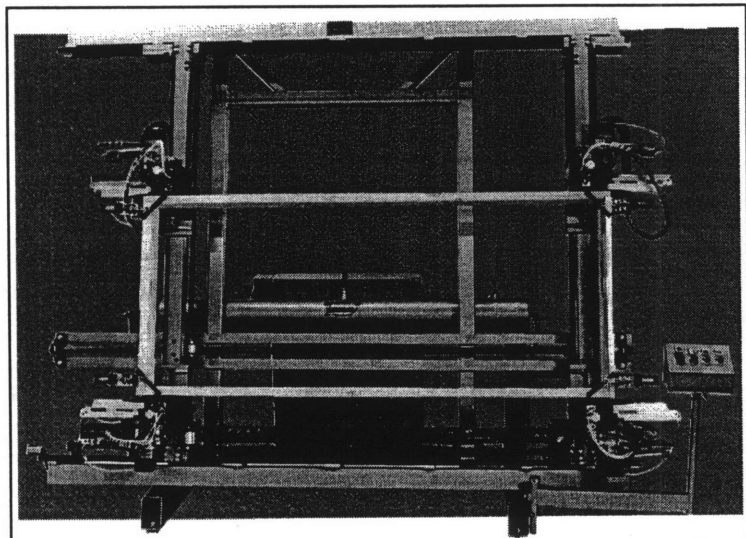
### 4.4.1 Marvin Windows

Marvin Windows utilizes numerous types of equipment in its Warroad, Minnesota window plant. Fully automated CNC machines are used to cut odd glass shapes, while special-sized windows are manually fabricated. The reader is referred to Chapter Seven for a detailed description of the operations and production equipment at that plant.

### 4.4.2 Millwork Technologies

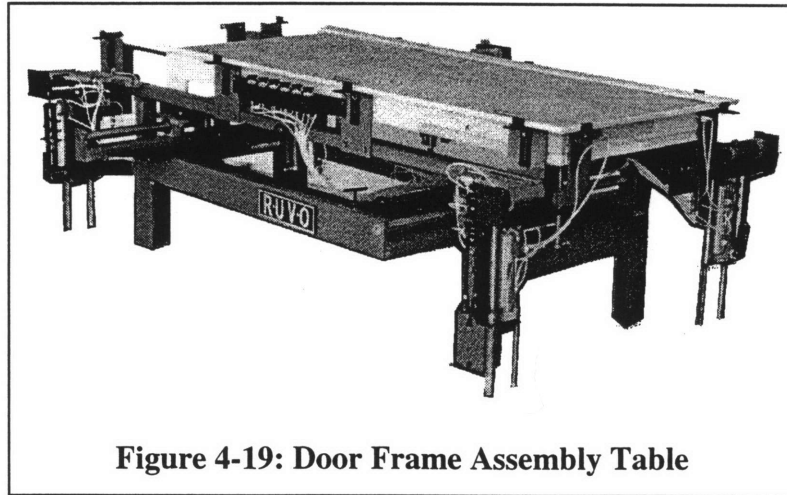
There are two types of millwork processes: those for the preparation of parts and those for the assembly of components. Preparation of wood parts involves milling, routing, and turning of lumber for window sash and frame parts, doors and door frames, moldings, prefabricated stairs, and other ornamental millwork.

Windows are also commonly fabricated from extruded vinyl and aluminum parts. The



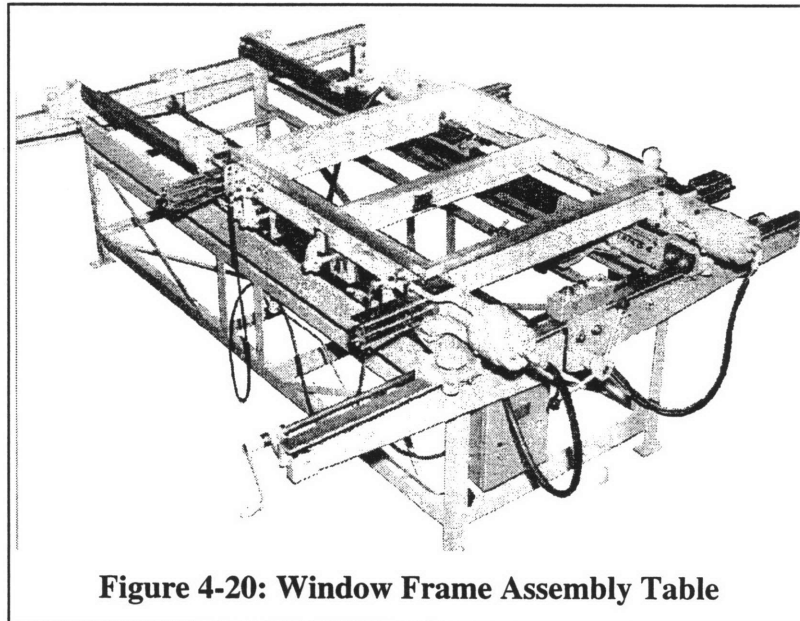
**Figure 4-18: Door Frame Assembly Machine**

newest material used in window frames is a fiberglass composite with a core of fiberglass insulation, produced with a pultrusion process.<sup>4</sup> The specific technologies used in part production are not discussed in detail here because this thesis focuses primarily on component assembly, not part fabrication.



**Figure 4-19: Door Frame Assembly Table**

Assembly is required for windows, doors, and stairs. Specialized equipment has been developed to ensure the quality and cost effectiveness of assembly operations. As shown in Figure 4-18, Figure 4-19, and Figure 4-20, vertical and horizontal variations of framing assembly machines and tables are used to fixture and square frame members for doors and windows. Likewise, as shown in Figure 4-21, stair assembly machines have been developed that are used for fixturing the stair components.

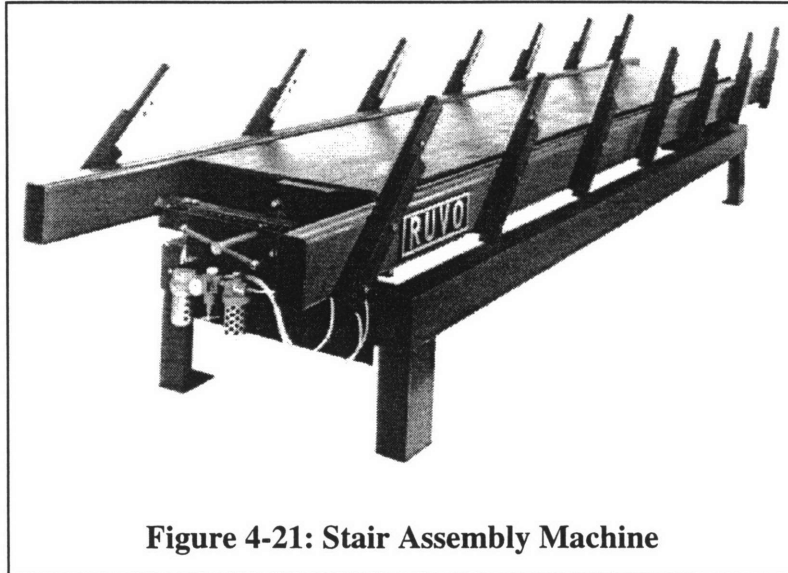


**Figure 4-20: Window Frame Assembly Table**

have been developed that are used for fixturing the stair components. Pneumatic-powered fasteners then connect the wood members.

---

<sup>4</sup> Piatak, John R., Jr., "Window Technology," Unpublished Report, MIT Center for Construction Research and Education.



**Figure 4-21: Stair Assembly Machine**

#### *4.4.2.1 Glass Manufacturing*

Some extremely sophisticated manufacturing technologies are being used to manufacture window glass. For example, there are two processes used to apply the low-E coating to glass used in high efficiency windows: a “soft-coat” method and a “hard-coat” method. A low-E coating is an energy reflecting coating for glass that greatly improves the thermal performance of the window. It has been called the “most important advance in window technology in the last decade.”<sup>5</sup> Sputtering is a process that produces a soft-coat on a glazing or film. It is performed in a vacuum chamber. The metal is deposited one atom at a time on the glazing or film by “bombarding the metal with ionized argon gas.”<sup>6</sup> The process is essentially identical to the vapor deposition process used in the fabrication of wafers in the semi-conductor industry. In the other method, which produces a hard-coat, the metal is sprayed directly on the surface of hot glass. Low-E coating of glass is likely to be performed by a glass manufacturer rather than a window manufacturer. .

Another sophisticated process forms a continuously curved piece of glass for use in a corner window. The glass is bent in a two stage process during which it is heated to a high temperature, allowing it to bend under its own weight. A computer controls the amount of

---

<sup>5</sup>St. John, Andrew, “The Sourcebook for Sustainable Design,” Boston Society of Architects, 1992.

<sup>6</sup> Piatak, John R., Jr., “Window Technology,” Unpublished Report, MIT Center for Construction Research and Education.



bending in the frame that supports the glass.<sup>7</sup> Marvin Windows takes this concept one step further. It can provide corner windows with glass bent at a ninety degree angle.<sup>8</sup>

#### 4.4.2.2 Window Production

King describes the typical production process for wood window manufacturing. As shown in Figure 4-23 (Taken from King, 1989), the first stage converts rough lumber into finished lumber, the second stage shapes the finished lumber, and the third stage involves assembly of the window. According to King, computer controlled automation entered the industry in the 1980's. The equipment included: computerized saws, flexible assembly fixtures, and computer controlled glass cutting. A typical computerized equipment control console is shown in Figure 4-22.

Despite some firms' use of high technology production equipment, capital investment per production worker is low for the overall millwork industry, at only thirty-five percent of the average for all manufacturing industries in 1989.

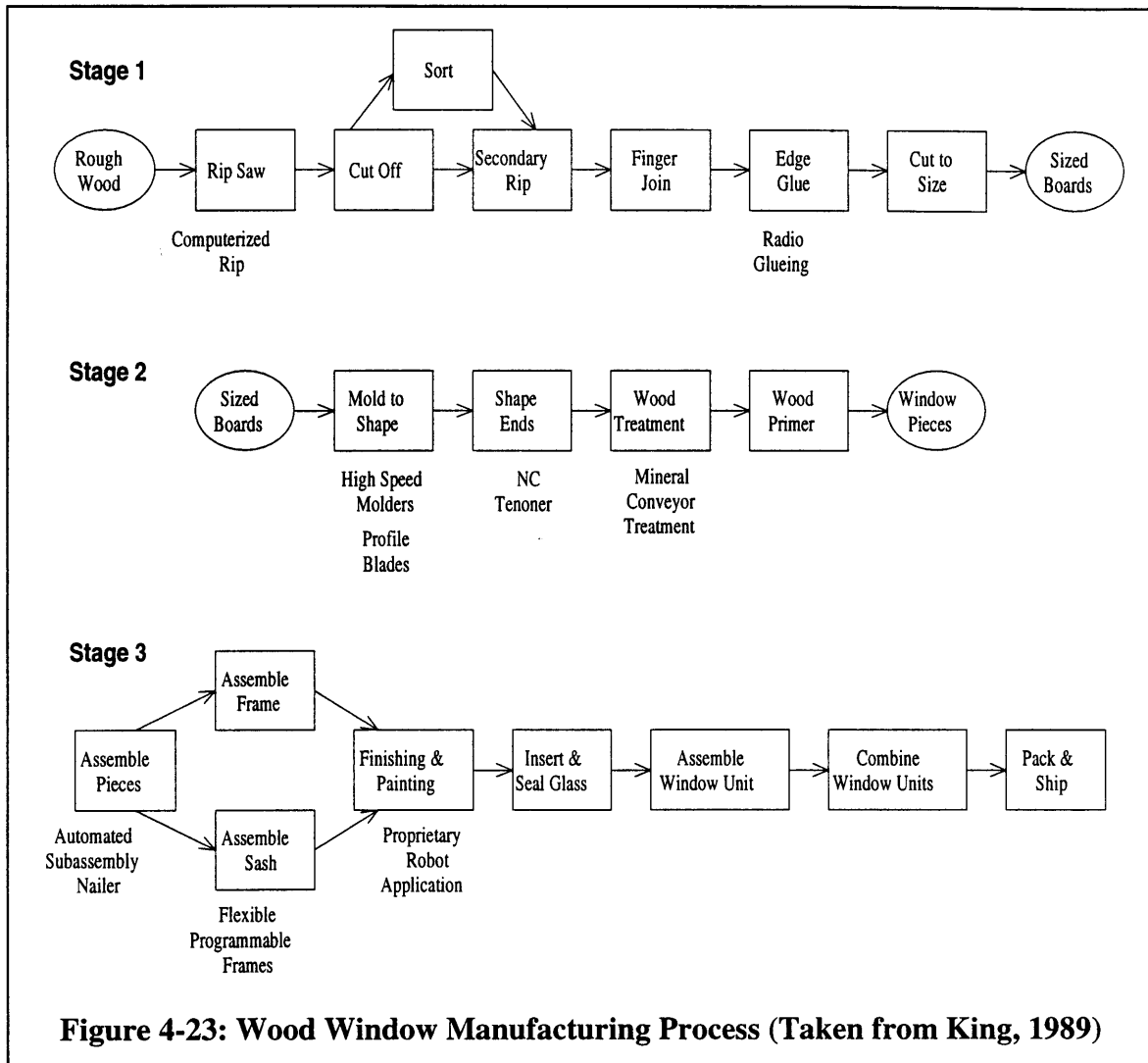


**Figure 4-22: Computer Control Console**

---

<sup>7</sup> Piatak, John R., Jr., "Window Technology," Unpublished Report, MIT Center for Construction Research and Education.

<sup>8</sup>Harris, John, "The Window Frame as Fashion Item," *Forbes*, April 30, 1990.



## 4.5 Wood Kitchen Cabinets

Wood kitchen cabinet production is largely accomplished through manually operated lumber processing machinery. However, there are two technological developments affecting production: improved fastener design and computerized cabinet design.

New concealed hinges and other fasteners have been developed that can be installed or partially installed with automated equipment or which enable easy manual installation into machine drilled holes.<sup>9</sup> The result has been a reduction in labor requirements for cabinet assembly.

---

<sup>9</sup>“Technology and Its Impact on Labor in Four Industries, Lumber and Wood Products/Footwear/Hydraulic Cement/Wholesale Trade” U.S. Department of Labor Bureau of Labor Statistics, Bulletin 2263, November, 1986.

More significantly, computers are beginning to be used in custom cabinet design to rapidly estimate the cost of an order and to calculate the required material cut lists, including dimensions for each piece and the manner in which each piece is to be cut. Adopters of the technology have realized a reduction in time required to estimate and design custom cabinets.

In addition, prototype systems have been developed that integrate CAD and CAM systems to produce custom milled doors. The milling machines are essentially identical in operation to standard CNC machines used for years in machining metal parts. One such prototype system has been shown to reduce the time required to design and manufacture a custom door by a factor of four.<sup>10</sup> Although such systems have yet to achieve widespread use in industry, they are certainly on the horizon.

A third use of computers by cabinet producers involves layout of cabinets. For example, Russo Brothers Cabinetmakers use 2D and 3D CAD models to ensure that custom cabinetry will fit into the surrounding space and to minimize material waste. Wire-frame drawings are generated from the 3D model to communicate the design to the production staff. In addition, they use rendered models to communicate the design to customers.<sup>11</sup>

## 4.6 Summary

The construction methods employed by off-site producers vary from fully automated plants to plants utilizing traditional methods of manual assembly. The fully automated operations are concentrated in the production of highly standardized products by a continuous process or with little or no variation from batch to batch (such as plywood, drywall, and some components). The assembly of prefabricated homes is characteristic of the opposite end of the spectrum, where virtually no automation is used. Workers in prefabricated home factories primarily use standard, on-site methods and materials.

Some advanced technologies are being used in the production of pre-assembled components (such as cabinets, windows, and window glass) and are also beginning to emerge in truss and wall panel manufacturing. However, the vast majority of the equipment used in off-site production consists of special purpose machines. The machines are typically manually setup, loaded, and unloaded. They have limited flexibility within a range of sizes. They are typically restricted to (and optimized for) a single function. The application of computer controls to this type of equipment will enhance flexibility.

---

<sup>10</sup>Bradley, C., and G.W. Vickers, "Integrated Design and Manufacturing Utilizing A Personal Computer: A Woodworking Industry Application," *International Journal of Advanced Manufacturing Technology* (1990) 5:214-223.

<sup>11</sup> "Millworker Fits CAD into Design Process," *Computer Graphics World*, May, 1995, pp. 60-61.

# 5. Computer Integrated Production Technologies

## 5.1 Introduction

“Computers are integral to almost every manufacturing process now in use.”<sup>1</sup> Following an introduction to some of the key concepts in manufacturing processes, this Chapter describes how computers are being used to integrate design, manufacturing process planning, and production. In addition, it describes how computers have created operational changes and strategic opportunities for firms.

### 5.1.1 Types of Manufacturing Processes

There are several general types of manufacturing processes, including: projects, job shops, line flows, and continuous processes. This classification follows a general progression of increasing volume, decreasing flexibility, increasing mechanization and automation, and increasing specialization of labor. To be effective, each type of manufacturing process requires different types of production technologies, different management techniques, and different organizational structures. Moreover, a firm should choose a process whose attributes match the characteristics of the market it serves.

*Projects* typically represent the creation of large or one-of-a-kind products. In a project shop, the object being manufactured is stationary due to its size and/or weight, and machines and resources move to and from the object.<sup>2</sup> Examples of the production of projects include the assembly of the space shuttle and the construction of a large building. With projects, production tends to utilize more manual processes than mechanized ones due to the inherent mobility of people and the required high level of production flexibility. For example, powered hand tools are common technologies utilized in project production.

*Job shops* are manufacturing processes that produce a large variety of products in relatively small volumes. Batch sizes usually range between one and one hundred. The classic example of a job shop is a general purpose machine shop. Job shops typically utilize unspecialized, general purpose machine tools that are easy and fast to set up and thus efficient for high variety production with small batch sizes. In a job shop, machines are arranged into groups by process function, and parts are routed to different machines as needed.

---

<sup>1</sup> Quote by Lawrence Oliva, Chairman of the AUTOFACT '94 conference and exposition on computer technology for manufacturing, reported in *The SME News*, Society of Manufacturing Engineers, September/October, 1994.

<sup>2</sup> Chryssolouris, George, *Manufacturing Systems Theory and Practice*, Springer-Verlag, New York, 1992.

*Line flows* and *continuous processes* are high volume processes utilizing a high level of automation but exhibiting relatively low flexibility.<sup>3</sup> Highly specialized workers perform narrowly defined tasks and special purpose machines churn out identical products. Parts flow through production in fixed, predefined routings. An automotive transfer line is the classic example of a line flow, while steel production is a continuous process. What makes these process types capable of high volumes is their specialization of functions and tasks. Machine tools are designed to optimize the performance of a narrowly defined task. The high expected production volumes justify the expense to develop these specialized machines.

All of the process types described exist in some form within the housing industry and its suppliers. On-site, housing production is clearly a project, since the house is stationary. On the other hand, off-site modular housing is typically produced with a line flow (assembly line), albeit a relatively low volume line flow. Materials and components for homebuilding are produced with job shops (customized windows, cabinets, pre-hung doors, trusses, etc.), line flows (stock windows, cabinets, pre-hung doors, etc.), and continuous processes (lumber, gypsum products, paints, etc.), depending on the type of product or component.

### **5.1.2 From Manual Machines to Computer Control and Beyond**

Computer-aided manufacturing (CAM) refers to the use of computer controlled machines to produce something. That something may be a machined part, an injection molded plastic component, or an assembled product. In order to fully understand CAM, it is helpful to understand the nature of production prior to and leading up to the development of CAM.

Prior to the industrial revolution and the advent of mass production technologies, products were hand crafted. Customization was high, as was cost, and products such as automobiles were made to order for the few who could afford them. Mechanization offered a variety of benefits, including greatly increased productivity, increased quality, and much higher rates of production. Yet, the principal benefit was that it reduced the cost of products to such a degree that it enabled the masses to afford them. The chief disadvantage of mass production was that the rigid production technologies demanded standardization of products. Variety and customization disappeared completely in some industries.

It is noteworthy that mass production did not eliminate craft production in all industries. Instead, the two systems coexisted, with industries as diverse as fur goods production, stone cutting, wood pallet production, and commercial printing still being dominated by

---

<sup>3</sup> Garvin, David A., "Types of Processes" Case Number 9-682-008, Harvard Business School, Boston, MA, 1981.

small firms.<sup>4</sup> Likewise, construction is one of the industries that mass production never penetrated. There are various reasons for this, notwithstanding that no one ever developed a system for general construction that could replace craft production. In the homebuilding segment of construction, several attempts were made to mass produce housing, but none reduced the cost enough to convince the consumer to sacrifice variety and customization, as mass production required.

Today, mass production is facing a serious challenge from the mass customization paradigm of production, made possible in part by decreases in the price/performance ratio of computers and in part by the development of flexible automation and robotics technologies (both hardware and software). Flexible manufacturing systems (FMS) promise the efficiency of mass production with the variety of craft production. Cutting edge firms can capture competitive advantage by using the capabilities of FMS to satisfy the consumer's innate desire for customized products. A detailed discussion of the key enabling technologies and techniques for flexible manufacturing is presented below.

### 5.1.3 CAD/CAM Terms Defined

CAD/CAM refers to the integration of computer aided design (CAD) and computer aided manufacturing (CAM) through a common database. Data generated in the design process is stored in the database and can be used to control the manufacturing process. The goal is to structure the design database so that manufacturing data and information such as part specifications and tool commands can be generated automatically. The manufacturing data can subsequently be sent to the machine tools (or people) responsible for manufacturing the part. The machining industry has achieved this level of CAD/CAM integration. Modern CNC (computer numerically controlled) machine tools are linked with CAD software. Tool paths for a CNC machine can be generated automatically. Computer aided process planning (CAPP) is the term that describes the automatic generation of the information required to produce the part. This information may include the required sequence of actions, spindle speeds and feed rates, tool selections, and more. CAPP is described in detail below and in Chapter Eight. Sometimes CAM systems also integrate multiple machine tools with automated material handling systems which transfer work in process ("w.i.p.") between machines. In these cases, CAPP may also generate part routing information.

For production of large numbers of identical parts, such as in mass production, a transfer line composed of specially designed machine tools is a logical solution. Transfer lines are optimized for the fast, efficient production of a single product. There is little benefit in electronically controlling single product transfer lines. The strength of the CAD/CAM linkage is realized when it is incorporated into *flexible* production systems.

---

<sup>4</sup> Pine, Buddie Joseph, II. "Paradigm Shift: From Mass Production to Mass Customization," MIT S.M. Thesis in Management of Technology, June, 1991.

As defined here, a flexible manufacturing system (FMS) is a collection of equipment, machinery, human workers, procedures, and information technologies that exhibit one or more types of production flexibility, including but not limited to:

- the ability to produce a variety of different products in various and constantly changing quantities;
- the ability to change the mix of products by adding new products, slightly changing existing product designs, or subtracting existing products, with little effort and with little or no or disruption to operations.

Computer-integrated manufacturing (CIM) refers to a much broader concept than CAM. CIM involves the creation of a firm-wide information technology infrastructure. Thus, all of the resources necessary for manufacturing operations, such as flexible machines, material handling and routing equipment, design engineering, production management, accounting and control, scheduling, shipping, and others, can be integrated. The electronic links between functions allow the fast and efficient transfer of data and information. CIM expands the benefits of CAM and FMS throughout the entire firm by creating a flexible organization capable of capitalizing on the flexibility of FMS.

#### **5.1.4 Flexibility**

Before continuing with a more detailed discussion of the advantages of flexible manufacturing systems and how they are achieved, this section defines some of the different types of process flexibility. Just as there are different types of flexibility, there are different ways to classify and define types of flexibility. The following definitions, which expand on the discussion provided in Section 2.6, provide a useful taxonomy for this paper and draw on the work of Gerwin<sup>5</sup> and Suarez.<sup>6</sup>

- *Mix flexibility* is the ability to produce a variety of different products (a *mix* of products) in different volumes and with the same production equipment. The computer controlled machines used in flexible manufacturing systems are capable of producing a wide range of products. Different products only require changes in tooling and part programs. (Part programs are machine readable instructions that control a machine. They can be predefined for different products and stored in the computer).

---

<sup>5</sup> Gerwin, Donald, "Do's and Don'ts of Computerized Manufacturing," Harvard Business Review, March-April, 1982.

<sup>6</sup> Suarez, Fernando F., Michael A. Cusumano, and Charles H. Fine, "Flexibility and Performance: A Literature Critique and Strategic Framework," MIT Sloan School Working Paper #3298-91-BPS, November 1, 1991.

- *Parts flexibility* is the ability to add to and subtract from the mix of parts over time. Most production systems can be altered to accommodate new parts. The advantage of the FMS is that the introduction of a new part is accompanied by little or no changeover costs.
- *Routing flexibility* is the ability to re-route products through different machines to balance production loads or to eliminate work stoppages in the event of a machine breakdown. For example, a CIM system which consists of several flexible machines and automated material handling equipment can easily re-route products to avoid a broken machine. Load balancing and optimal equipment scheduling contribute to efficiency.
- *Design change flexibility* is the ability to quickly implement design changes into active production. Today, flexibility and time are key sources of competitive advantage.<sup>7</sup> In order to be responsive in today's market, firms now must shorten both the processing time in the factory and the production planning time to speed time to market. Design change flexibility allows producers to introduce more frequent design changes in existing products and more frequent introductions of new products by minimizing the time required for process planning as well as the equipment changeover time. Thus, producers are able to respond faster to changes in market demand. Stalk<sup>8</sup> reports how Honda Motorcycles used design change flexibility to decisively win a variety war with Yamaha Motorcycles. When Yamaha challenged Honda's position as market leader by opening a huge new factory, Honda responded by introducing or replacing 113 models in eighteen months, while Yamaha managed only thirty-seven design changes.
- *Volume flexibility* is the ability to vary the production volume of a given product with little or no effect on the unit cost of the product. The old approach to maintaining volume flexibility was to maintain excess capacity.<sup>9</sup> With an FMS, volume flexibility occurs since available production resources can be redirected to and from other products in times of low or high demand. Aggregate demand, however, is still relatively inflexible with an FMS if it includes a high percentage of fixed cost resources.

---

<sup>7</sup> Stalk, George, Jr., *Time – The Next Source of Competitive Advantage*, Harvard Business Review, July-August, 1988.

<sup>8</sup> Stalk, George, Jr., *Time – The Next Source of Competitive Advantage*, Harvard Business Review, July-August, 1988.

<sup>9</sup> Wheelwright, Steven C.. and Robert H. Hayes, "Competing Through Manufacturing," Harvard Business Review, January-February, 1985.



### **5.1.5 Flexibility's Operational Benefits and Effects on Production Organizations**

It has been found that flexible CNC machining centers can reduce setup time and floor space by two-thirds, direct labor by half, and work in process inventory by ninety percent.<sup>10</sup> These and other advantages and benefits of FMS/CIM over rigid mass production systems result directly from the types of flexibility inherent in the systems.

- Training and changeover costs for new product introductions are lower than for mass production. Since the basic operation of the equipment is unchanged for different products, additional training cost and time are low, creating design change flexibility and parts flexibility.
- With computer controlled machines, design changes and adjustments require only a change of instructions to the machine. Thus, equipment changeover costs are confined to the development of new part programs and possibly tooling. If part programming is automated or semi-automated, as is the case with computer aided process programming (CAPP), these costs are further reduced.
- Volume flexibility allows shorter production runs of more customized products, thus minimizing the reliance on long term market forecasting and the corresponding errors that occur.
- Computer control of machinery allows greater monitoring and control of processes, resulting in improved quality and reliability of both products and processes. In addition, computer controlled machines have shorter setup times.
- Improved quality and reliability allow the reduction or elimination of safety stocks, thus reducing the work in process inventory and resulting in faster throughput and decreased capital requirements.
- Improved quality and reliability also result in the reduction of waste, since products are created without defects the first time.
- Closer monitoring and control, coupled with routing flexibility allow maintenance to proceed as needed or according to a schedule. Therefore, maintenance costs are more predictable.
- Interruptions due to missing materials or parts or machine breakdowns are reduced since routing is better controlled and more reliable.
- Processing capability can be distributed to several locations or plants as needed to minimize shipping and/or other logistical costs. In other words, since high production

---

<sup>10</sup> Gerwin, Donald, "Do's and Don'ts of Computerized Manufacturing," Harvard Business Review, March-April, 1982.

volumes are not required, products can be made in several locations near their target markets rather than at one large, centrally located, mass production facility.

- Since production resources are shared among products, fewer are needed, so space required for production is minimized.
- Minimal space is necessary for work-in-process and finished goods inventory since products can be made as needed.
- CIM allows the integration of all areas in the production floor through information technology, minimizing the cost of communication and coordination.
- High levels of automation and equipment utilization lead to high labor productivity.
- In some cases, production can proceed untended. This capability is important for industries facing skilled labor shortages, hostile labor sources, or cyclical demand.

#### *5.1.5.1 Labor Productivity vs. Capital Productivity*

In the past, firms have focused on increasing labor productivity through capital investment. The strategy has typically been implemented in two steps. First, machines replace some workers, reducing the required labor. Subsequent increases in productivity result from the introduction of larger, faster equipment and through learning curve effects.

With FMS and CIM, the focus shifts to increasing capital productivity by decreasing inventory and work-in-process. In fact, finished goods inventory can be eliminated completely. An efficient order processing and delivery system coupled with a flexible manufacturing system leads to customized products on demand and rapid turnaround. Product quality is improved, throughput times are reduced, and the firm responds faster to customers' needs. Since customization does not require large retail inventories, intermediate level wholesalers and distributors can also be reduced or eliminated.

Capital savings due to inventory reductions can be very significant. In manufacturing, an amount equal to one-third of annual value added or fourteen percent of annual output is tied up in inventory.<sup>11</sup> In 1989, that amounted to 360 billion dollars. It was reported that if manufacturing inventory could be cut by twenty-five percent over the next decade, over one hundred billion dollars would be made available for manufacturing investments elsewhere.<sup>12</sup> In addition, reductions in manufacturing inventories can be accompanied by

---

<sup>11</sup> Ayres, R. U., R. Dobrinsky, W. Haywood, K. Uno, and E. Zuscovitch, *Computer Integrated Manufacturing, Volume IV: Economic and Social Impacts*, Chapman & Hall, London, 1992.

<sup>12</sup> Ayres, R. U., R. Dobrinsky, W. Haywood, K. Uno, and E. Zuscovitch, *Computer Integrated Manufacturing, Volume IV: Economic and Social Impacts*, Chapman & Hall, London, 1992.

additional reductions in wholesale and retail inventories, which usually total \$1.13 for every dollar of manufacturing inventory.

#### 5.1.5.2 *Competition, Profits, and Wages,*

Another benefit of FMS/CIM is the creation of high paying jobs. Competition based on price, which is typical of mass markets, favors low wage nations. Customized products yield competition based on differentiation. Firms can focus on the high value added of customized products and can expect to receive a premium for the specialized functionality. For example, the Levi Strauss company has adopted a mass-customization approach to production of some of its clothing. The consumer can purchase clothing sized and cut specifically for them. The cost is higher than the cost of the same product in a standard size, yet it costs significantly less than a similar custom tailored garment. Since higher skill levels are required to produce a range of high quality products simultaneously than are required for mass production, firms will pass on some of the premium received to labor. Thus, wages will be high.<sup>13</sup>

Management must shift its focus from reducing variable costs, such as labor, to creating strategic manufacturing assets. For example, firms should focus on increasing process capability, developing parts programming systems, and investing in the skills of the workforce.<sup>14</sup> Manufacturing assets are critical to the long term competitive position of a firm because once its competitors have adopted the technology, most variable costs will have been converted to fixed costs. Therefore, competition may again focus on price since costs are sunk and firms will try desperately to maintain demand. Because of fixed costs, mass producers try to stabilize and expand the market, using price concessions in times of sluggish demand.<sup>15</sup> Thus, a firm must continually create new products better than other firms and must continually create physical assets such as better programmed and better managed equipment. In this environment, the creation and management of intellectual capital becomes the most important task for management.<sup>16</sup>

---

<sup>13</sup> Sonntag, Victoria, "Flexible Manufacturing... From A Different Perspective," *Industrial Engineering*, November, 1990.

<sup>14</sup> Sonntag, Victoria, "Flexible Manufacturing... From A Different Perspective," *Industrial Engineering*, November, 1990.

<sup>15</sup> Haskins, Robert, and Thomas Petit, "Strategies for Entrepreneurial Manufacturing," *The Journal of Business Strategy*, November/December, 1988.

<sup>16</sup> Jaikumar, Ramchandran, *Postindustrial Manufacturing*, Harvard Business Review, November-December, 1986.

### 5.1.5.3 Learning

Under CIM, the traditional learning curve for labor is eliminated, as workers no longer focus on the continuous production of a single product. Instead, the responsibility for continuous improvement shifts to manufacturing engineers. Continuous improvement and innovation become even more important to the firm, since they replace economies of scale as the means for continued cost reductions.<sup>17</sup> Design and programming are critical skills, along with the ability to capture process capability information into product design.<sup>18</sup> Thus, software development lies at the heart of this information intensive manufacturing system.<sup>19</sup>

### 5.1.6 Strategic Benefits of FMS

Throughout business history, cost, quality, flexibility, and time have all been employed as sources of competitive advantage. Firms continually seek new sources of advantage to offset currently waning sources and to counter the competitive advantages developed by other firms. For example, prior to the introduction of mass production technology, quality and flexibility were focal points for strategy, as typified by master craftsmen. Cost and production time were both high for products produced by these skilled artisans. When mass production was introduced, firms utilized the cost and time advantages inherent in the technology to erode the quality advantages of the master craftsmen.

Throughout the nineteenth and twentieth centuries, mechanized production technologies were introduced into manufacturing operations and resulted in enormous increases in productivity.<sup>20</sup> In this age of mass production, firms would seek competitive advantage by capturing economies of scale. This strategy rests on the assumption that unit costs will decrease as production volume increases, through the introduction of expensive but highly efficient special purpose mechanized equipment. The equipment cost is justified by the expected high production volume, which allows fixed costs to be amortized over a large number of units. Thus, cost was the primary focus for management. In fact, hierarchical organizations were designed and set up around the goal of rigidly controlling costs. Production rates were high. However, flexibility was severely impaired and in some cases,

---

<sup>17</sup> Sonntag, Victoria, "Flexible Manufacturing... From A Different Perspective," *Industrial Engineering*, November, 1990.

<sup>18</sup> Goldhar, Joel D. and Mariann Jelinek, "Plan for Economies of Scope," *Harvard Business Review*, November-December, 1983.

<sup>19</sup> Jaikumar, Ramchandran, *Postindustrial Manufacturing*, *Harvard Business Review*, November-December, 1986.

<sup>20</sup> Ayres, R. U., R. Dobrinsky, W. Haywood, K. Uno, and E. Zuscovitch, *Computer Integrated Manufacturing, Volume IV: Economic and Social Impacts*, Chapman & Hall, London, 1992.

quality was reduced. Nonetheless, since much of the population was in need of low cost basic goods, this strategy was timely and very successful.

Over the past few years, there has been a gradual shift away from traditional mass production. As incomes grew and consumers became able to afford more than just basic necessities, consumers began to demand more than just low cost, as evidenced by the recent quality movement. Today, consumers are extremely conscious of product quality, and many firms have successfully achieved competitive advantages based on quality. In addition, today's consumers want customized goods and can afford to pay for them. In theory, customized goods have greater value since they are tailored to a particular customer, rather than satisfying the "average" preferences of the market.

Thus, there are several reasons that firms have begun to focus on flexibility, and in particular, on increasing flexibility in manufacturing.<sup>21</sup>

- Firms want to produce higher value, more customized goods.
- Most basic needs in western society have been filled. Therefore, greater incomes have stimulated diversified consumption.
- Shifts in industry structure due to advances in microelectronics, telecommunications, new materials, biotechnology, etc., have increased uncertainty in the business environment, placing a premium on the ability to react quickly to the market. Thus, flexible firms are likely to outlast rigid producers.
- Increasing global competition has caused firms to seek new sources of sustainable competitive advantage.

A focus on flexibility complements the current trend towards corporate downsizing. Firms must be able to respond to the constant changes in today's increasingly volatile marketplace. So called "agile" manufacturing or lean production combines flexible manufacturing technology with flexible organizational structures (non-hierarchical, flatter organizations) and innovative management techniques (like team-based production). The result is a state-of-the-art producer that is capable of winning in today's marketplace.

Regardless of the underlying reasons are that are driving the shift to increased flexibility, flexible manufacturing systems and CIM have drastically altered the competitive landscape in manufacturing. By making it possible for producers to meet the new demands of the marketplace, FMS/CIM has acted to reverse the trend toward inflexible mass

---

<sup>21</sup> Ayres, R. U., R. Dobrinsky, W. Haywood, K. Uno, and E. Zuscovitch, *Computer Integrated Manufacturing, Volume IV: Economic and Social Impacts*, Chapman & Hall, London, 1992.

production.<sup>22</sup> Flexible manufacturing systems provide a strategic response to today's market realities. The strategy of flexible manufacturing is to create and capture economies of scope, thus countering the economy of scale advantage of mass producers. Economies of scope develop as a result of computer controlled equipment that is capable of producing a large variety of products in relatively low volumes and at a lower overall cost than would be required to make the products on separate equipment.<sup>23</sup> No longer is a large production volume of a single product necessary, as the cumulative production volume of multiple products is sufficient.

### **5.1.7 Barriers to the Adoption of FMS in Manufacturing**

In spite of the benefits of FMS, U.S. firms have been slow to adopt the new technologies. Reported barriers to adoption include: organizational inertia, financial limitations, and other technical and non-technical reasons.

Flexible manufacturing systems are not applicable to all types of production. In continuous processes and mass production, operations are cost effective, use dedicated machinery and equipment, and are already automated. The only mass produced products that FMS technology is applicable to are those in which variety will lead to an increase in value added. The underlying assumption of flexible production is that producers will be better able to satisfy consumers, since they will offer more customized products, and that consumers will be willing and able to pay for the increased value.

Batch or job shop production is typically intermittent, has higher unit costs, and uses manually operated general purpose tools. Much of batch production lacks automation because the cost of non-flexible automation can not be justified for such low, intermittent production volumes. Batch production represents thirty-six percent of manufacturing GNP in the United States.<sup>24</sup> It is desirable to automate these tasks, since automation provides numerous benefits, including improved product quality.<sup>25</sup> Flexible manufacturing systems can potentially be used to automate some batch processes.

---

<sup>22</sup> Gerwin, Donald, "Do's and Don'ts of Computerized Manufacturing," *Harvard Business Review*, March-April, 1982.

<sup>23</sup> Goldhar, Joel D. and Mariann Jelinek, "Plan for Economies of Scope," *Harvard Business Review*, November-December, 1983.

<sup>24</sup> Gerwin, Donald, "Do's and Don'ts of Computerized Manufacturing," *Harvard Business Review*, March-April, 1982.

<sup>25</sup> Wheelwright, Steven C. and Robert H. Hayes, "Competing Through Manufacturing," *Harvard Business Review*, January-February, 1985.

Another reason for the slow adoption of flexible production early in its development in this country was that many American firms did not understand FMS.<sup>26</sup> Gerwin stated that one firm in five lacked an understanding of advanced process technology.<sup>27</sup> According to a study by Jaikumar, the average number of parts made by an FMS in the United States was ten, while in Japan it was ninety-three. In fact, seven of the thirty-five U.S. firms that were studied produced only three different parts. Annual production volume per part in the U.S. was 1727, while in Japan it was 258. In addition, Japanese firms introduced twenty-two times the number of new parts that the U.S. firms did during the time frame of the study.<sup>28</sup> Clearly, these facts demonstrate that early in the development of the technology, U.S. managers lacked an understanding of the concepts and strategic benefits of flexible manufacturing systems.

Another barrier to adoption of FMS technology is its high initial cost. The initial cost of an FMS is higher than a traditional rigid production system. In some cases, the perceived investment risk is high due to the size of the investment relative to total company resources.<sup>29</sup> Therefore, firms have difficulty in justifying cost using traditional cost/benefit financial analyses.<sup>30</sup> <sup>31</sup> Since an FMS costs more initially, it will cost more to produce a few specified parts, but it will be able to produce other as yet unspecified parts in the future. The unspecified parts in all likelihood will be designed to better match the needs of consumers, yet can be made with the same production system. This intangible strategic benefit is difficult to evaluate in a financial model.

In addition, since the shift to flexible production from mass production requires a complete reversal of strategy and significant organizational restructuring, mass producers have an extremely difficult time creating and executing the necessary changes without destroying the organization. Such fundamental changes require the maximum commitment from top management. However, it has been reported that in many organizations that have

---

<sup>26</sup> Jaikumar, Ramchandran, "Postindustrial Manufacturing," *Harvard Business Review*, November-December, 1986.

<sup>27</sup> Gerwin, Donald, "Do's and Don'ts of Computerized Manufacturing," *Harvard Business Review*, March-April, 1982.

<sup>28</sup> Jaikumar, Ramchandran, "Postindustrial Manufacturing," *Harvard Business Review*, November-December, 1986.

<sup>29</sup> King, Robert A., "Overcoming Manufacturing Myopia," *The Journal of Business Strategy*, September/October, 1988.

<sup>30</sup> Gerwin, Donald, "Do's and Don'ts of Computerized Manufacturing," *Harvard Business Review*, March-April, 1982.

<sup>31</sup> King, Robert A., "Overcoming Manufacturing Myopia," *The Journal of Business Strategy*, September/October, 1988.

attempted to implement the technology, management was not strongly enough committed to improvement.<sup>32</sup>

Firms need to overcome these barriers to the technology. Moreover, they should actively move toward lights out capability. Whether or not it is desired, the requirements for lights out production — impeccable quality, defect-free production, robust equipment, etc. — help improve lighted operations. Developing lights out production is so difficult that it leads to advance problem solving and continuous process improvement. This learning is a source of *sustainable* competitive advantage.<sup>33</sup>

## 5.2 Computer Aided Manufacturing

As defined in Section 5.1.2, Computer-aided manufacturing (CAM) refers to the use of computer controlled machines to produce something. This section describes some of the production systems and numerous processes that have successfully utilized CAM technologies. In addition, it describes the components of these CAM systems.

### 5.2.1 CAM Applications and Automation of Assembly

Computer aided manufacturing includes the use of computer controlled machine tools, automated material handling devices, and robotics. Today, automated processes include: machining processes, die casting, injection molding, spot and arc welding, de-burring, installation of screws and rivets, spray painting, and others. Automated material handling processes include: machine tool loading, palletization and de-palletization of parts, and material handling in investment casting, forging, and foundry applications. CAM is also used extensively in the production and assembly of electronics and electronic products.

However, the machining industry has achieved the most *widespread* adoption of automated manufacturing technology. Fully automated, computer numerically controlled (CNC) machining centers are commonplace. CNC machines exist for milling, turning, drilling, and other material removal tasks.

In contrast, automated assembly systems have achieved only marginal use. Assembly is much more complex, incorporating the tasks of material handling, fixturing, fastening, inspecting, packaging, and others. Thus, most flexible assembly systems have not achieved the same level of automation as machining systems. One experimental system has been developed that attempts to overcome these technological barriers. The “Archimedes”

---

<sup>32</sup> King, Robert A., "Overcoming Manufacturing Myopia," *The Journal of Business Strategy*, September/October, 1988.

<sup>33</sup> Jaikumar, Ramchandran, "Postindustrial Manufacturing," *Harvard Business Review*, November-December, 1986.



system is a fully automated flexible assembly system for nuclear weapons production.<sup>34</sup> It utilizes a flexible assembly control program which can derive the commands for controlling the robotic assembly machines from information found in a three dimensional CAD model of the product.

Two factors hinder the widespread use of automated assembly equipment: insufficient flexibility and a lack of intelligence in existing systems.<sup>35</sup> The importance of flexibility was presented above. Intelligence refers to the ability of humans to judge situations and make decisions based on sensory data in real time. Duplicating the sensory capabilities of humans is difficult and costly. Another difficulty in automated assembly is the variability of the parts being fed to the machine. As the variability of incoming parts decreases, so does the need for sensing and intelligence. Therefore, these problems are directly linked.

There is a direct relationship between flexibility of hardware and sophistication of software. Dedicated automation (such as a transfer line) requires unsophisticated software but lacks flexibility. Robots require very sophisticated software to perform a similar task but have the flexibility to do a variety of tasks. Thus, flexible production system development requires the development of sophisticated software systems that are capable of accurately planning and controlling the production and assembly of parts with flexible machinery and robotics.

As sensor technology improves, systems will be able to collect sensory data and production software will interpret the data in real time. Such sensor technology will help to improve the accuracy and speed of flexible assembly systems. Furthermore, sensor integrated systems will have the ability to control the process in the presence of disturbances.

Since the quality and consistency (low variability) of inbound materials is important, automated assembly systems may benefit from the precise automated production of the parts to be assembled. In effect, the automation of an entire production system may be possible even though automating the final assembly operation alone may be impractical.

Goetsch presents a list of criteria to be considered when determining the applicability of automation to an assembly process.<sup>36</sup> He suggests that an affirmative answer to the following fourteen questions will provide a reasonable expectation for success given the current state of technology.

---

<sup>34</sup> News Release from Sandia National Laboratories, Albuquerque, NM. January 12, 1990.

<sup>35</sup> Goetsch, David L., *Advanced Manufacturing Technology*, Delmar Publishers, Inc., Albany, NY, 1990.

<sup>36</sup> Goetsch, David L., *Advanced Manufacturing Technology*, Delmar Publishers, Inc., Albany, NY, 1990.

1. Is the assembly simple and made of few parts?
2. Do the parts lend themselves to automated inspection?
3. Are the parts light and easy to handle?
4. Is the product relatively free from design changes?
5. Is the product free from complex joining and fastening procedures?
6. Are manual assembly times long?
7. Are manual assembly costs high?
8. Does the manual process have a high rejection rate?
9. Is the product needed in large volume?
10. Are qualified personnel available to operate an automated assembly system?
11. Are qualified personnel available to maintain an automated assembly system?
12. Will a conversion be free of labor problems?
13. Is top level management knowledgeable enough of automated assembly to have a responsible decision?
14. Is top level management committed enough to automated assembly to make the front end investment?

In the context of off-site production of components for housing, the answer to many of those questions is no. Therefore, if automated assembly is to be successful in off-site production, the state-of-the-art in production technology must advance, the product must be redesigned for ease of automated assembly, and firms must make the necessary organizational changes. However, automated information processing for manual assembly operations is not precluded and is described in later chapters.

## **5.2.2 Production System Components**

Automated production systems are composed of three broad types of components: production machines, material handling equipment, and control systems.

### *5.2.2.1 Production Machines*

Production machines consist of a broad class of machines that perform operations on materials. The key component of a production machine is the tool it uses to perform work. Tools are either manipulated by industrial robots (as in automated welding) or are held fixed while the materials are moved (as in milling). In assembly operations, production machines refer to the machines that hold and connect the parts. Typical fastening technologies for automated assembly include mechanical and adhesive connections, welding, brazing, and soldering.

Most flexible automated production systems incorporate robots as production machines and/or material handlers. There are many different types of robotic manipulators. Two common types, gantry (Cartesian) robots and revolute robots, differ in the types of motion performed by the axes. Gantry robots, which perform Cartesian motions, are suitable for heavy loads, have relatively large work envelopes, and are easy to program. Standard six degree of freedom revolute manipulators are suitable for lighter loads, have smaller work

envelopes, and are somewhat more difficult to program. However, they are slightly more flexible than gantry robots.

Important considerations when determining the best manipulator type for a task include the required load capacity, the cycle time, the required accuracy, the required repeatability, the work envelope, and the type of motion (point-to-point motion, linear motion, or motion along a contour). For most assembly operations, gantry robots are considered to have the best configuration.

#### *5.2.2.2 Material Handling Equipment*

Material handling equipment includes robotic manipulators, orienting devices, part fixtures, part feeding mechanisms, and transfer devices. These devices position the materials at the workface and transfer them between production machines. In the case of assembly, they provide the production machines with parts for the assembly. Automated feeders for parts can be classified as rotary bowls, orbital bowls, vibratory bowls, straight-line vibrators, and belt conveyors. These machines were developed in response to the need to orient parts with complex shapes as they were being fed to production machines.

The most important component of a robot is the end effector. An end effector either functions as a material handler and holds the work piece, or it functions as a tool holder and operates on a fixed work piece. The most widely used robotic end effectors are grippers, which can be actuated either mechanically, magnetically, or by vacuum. However, some special purpose end effectors have also been developed. Often a robot will have multiple end effectors at its disposal, and will make tool changes automatically as needed.

#### *5.2.2.3 Sensors*

Sensors are utilized in process control to provide feedback information. Sensors allow production systems to adapt to changing conditions. Systems which lack sensing ability require a rigidly fixed working environment. There is a strong need to be able to adapt to different conditions, especially in assembly operations, where unsuitable parts must be recognized. Assembly requires the connection or joining of various parts, each having a corresponding tolerance. As some non-conforming parts will inevitably be fed to the assembly station (one hundred percent perfect parts implies infinite cost in manufacturing theory), they must be dealt with in a suitable fashion.

The types of sensors in automated systems include sensors that are internal to the machine and external sensors designed to capture data about the surrounding environment. Internal sensors measure positions, velocities, and accelerations, which are used in low level feedback control, as well as forces (such as the gripper force of a robot), which can be used to identify the process state. External sensors include force sensors, proximity sensors, tactile sensors, pneumatic sensors, optical sensors, vision systems, range sensors, safety “kill” switches, and others, which also can be used to measure process state

variables. An adaptive controller can use information regarding the process state to close the loop on the process, as described in Section 5.3.6.1.

There are many types of sensors that *can* be used in automated systems. However, sensors are expensive and software to interpret sensor data is often complex, so the system designer must determine when sensors are economical and what types of sensors to use in the control of the process.

## **5.3 Computer Aided Process Planning**

The objective of this section is to describe computer aided process planning (CAPP), the role of CAPP in flexible manufacturing systems, how CAPP works, and difficulties encountered with designing and implementing CAPP systems.

### **5.3.1 Need for CAPP**

In the days of mass-production, machines were designed to do one task as quickly and as inexpensively as possible. Machines were not computer controlled, nor would it have been beneficial. Essentially, a machine's "process plan" was fixed by its mechanical limitations. During the last twenty years, manufacturing has undergone a fundamental shift in philosophy. While cost is still important, quality, flexibility, and time have become equally important. Process planning represents a significant contributor to the time and cost of new product introductions. In highly flexible production environments that make products to order, each product may require the development of a unique process plan.

A flexible manufacturing system can economically produce a wide variety of parts. Its source of flexibility is two-fold: a flexible material processing component and a flexible information processing component. With CAPP, a computer aids in the generation and/or delivery of the information to be utilized by the information processing component of the flexible manufacturing system.

Ultimately, the degree of flexibility required of a production system, as measured by the average batch sizes and the number of product variations, determines whether a CAPP system is needed. For extremely large batch sizes, off-line programming is more cost effective than CAPP. Likewise, if the system is designed to only make a few parts, (even up to a hundred or so varieties) automated process planning is unnecessary. With off-line programming, process plans can be manually programmed, stored in a database, and recalled when needed. However, when each part is unique, or when the number of possible combinations reaches the thousands or tens of thousands, predefining and storing plans becomes uneconomical. Thus, plans must be generated as one of the preliminary steps in production. Plan generation can be either manual or automated. The benefits of automated generation are below.

It should be reiterated that line flows (like assembly lines in mass production) and continuous processes (like chemical refining) have too narrow and too highly standardized product lines for CAPP systems to be useful. Since only a few products will ever be

produced on the line, each program can be written a priori, stored in a library of plans, and retrieved when needed. Unique projects are also not well suited to CAPP. Since a one-of-a-kind project can have almost infinite variety, the complexity of a system for planning would be beyond the scope of today's artificial intelligence software. Also, since hardware does not exist to manufacture such products, numerical part programs are not necessary so the scope of the process planning function is narrowed. Therefore, CAPP is only applicable to job shops and batch processes which have domains that can be constrained enough to be modeled.

### 5.3.2 Benefits of CAPP

As stated above, flexible manufacturing requires the generation of process plans. While plans could be generated manually, computer aided process planning has been developed and used extensively in some industries, particularly in machining. There are several reasons why it has been developed, and why computer generated plans are advantageous.

- A computer can generate a plan faster, so the turnaround time for incoming orders is reduced.
- Manually generated process plans are more likely to contain mistakes.
- Process planning is a complex, knowledge intensive activity and requires a significant experience base. Due to the disparate nature of experiential knowledge, manual process planning produces inconsistent plans across planners. For example, two equally experienced process planners will likely develop different process plans for the same part. A computer generated plan is consistent. Every time the inputs are the same, the same plan is generated.
- Although two plans generated by two different experienced planners will likely be inconsistent, and although both will likely be satisfactory, neither may be optimal. The optimal plan may only be generated through an analysis of large amounts of manufacturing process and cost data, which cannot be performed efficiently or effectively by a human planner. Computers can potentially be used to generate an optimal process plan.

However, when considering "optimal" process planning, we must be careful to consider the domain over which the optimization will occur. Nordland raises the issue of sub-optimality. He claims that many of the existing attempts to implement "optimum" process planning algorithms will be problematic when enterprise wide integration is achieved.<sup>37</sup> The problem is that many of the solutions are locally optimal but will cause the manufacturing operation as a whole to operate sub-optimally. Since planning considerations occur at many levels, an optimizing approach to planning should be capable of multi-level planning.

---

<sup>37</sup> Nordland, Gerald L., "Integrating CAPP into Factory Management Systems," *Manufacturing Systems*, February, 1985.

CAPP also is a key element of concurrent engineering. The goal of concurrent engineering is to link the design and manufacturing phases. In a sense, design is viewed as the first step in the manufacturing process. Design and manufacturing can be linked by linking the computer tools used in each process — design's CAD system and manufacturing's CAM system. CAPP forms this linkage. There are three benefits to design-manufacturing integration: to eliminate design rework due to errors of omission or commission; to improve manufacturability by providing real time feedback to designers; and to decrease the product development cycle time by making product design and process planning simultaneous tasks rather than sequential tasks. Successful implementations of concurrent engineering have resulted in reductions in manufacturing costs of up to seventy-five percent, reductions in engineering change orders of sixty-five to ninety percent, reductions in development time of thirty to seventy percent, and reductions in time to market of twenty to ninety percent.<sup>38</sup>

A final reason that CAPP is advantageous is that in recent years, skillful process planners have become harder to find.<sup>39</sup> At the same time, the importance of detailed instructions at the shop floor level has increased due to a decline in shop floor skills at both the supervisory and operator levels.<sup>40</sup> CAPP provides a cost effective way to automatically generate and transfer required production information to the shop floor. Thus, CAPP has become increasingly attractive from the technical perspective, the human resource/management perspective, and the financial perspective.

### **5.3.3 Types of Information Needed for Production**

CAPP encompasses the generation of all of the information required to manufacture a part. That information may be transferred to and used by a machine or a human worker. In the former case, consistent communication requires strict formatting conventions and communication protocols. In the latter case, it is important that the required information be provided in a timely manner and in a easy to understand form. Depending on the application, process planning information could be as simple as an order form with a part number or as complex as a detailed step-by-step set of directions for fabricating a custom product. Some of the potential types of information include:<sup>41</sup>

---

<sup>38</sup> Balaguer, Nancy S., and Mary Addonizio, "A Note on Design-Manufacturing Integration," Harvard Business School Case 9-191-202, 1991.

<sup>39</sup> Nordland, Gerald L., "Integrating CAPP into Factory Management Systems," *Manufacturing Systems*, February, 1985.

<sup>40</sup> Logan, Frank A., "Process Planning Via Manufacturing Codes," *CAPP: From Design to Production, First Edition*, SME, 1988.

<sup>41</sup> Nordland, Gerald L., "Integrating CAPP into Factory Management Systems," *Manufacturing Systems*, February, 1985.

- the sequence of operations to be performed;
- the work centers and machines to be used;
- production and setup times;
- the labor required for setup and run time;
- the cost centers involved;
- the gross material required;
- for automated machines, a computer numerical control (CNC) program; (Machine tool controllers use “G-codes” and “M-codes,” a language used to program the machine to perform a desired sequence of operations. CAPP systems for machining centers automatically generate G-codes and M-codes based on a CAD representation of the part.)
- for a manually controlled machine, feed rates, speeds, and machine settings;
- a list of miscellaneous tools or measuring devices required;
- any subcontracts or outside suppliers needed;
- for a manual operation, a design sketch, drawing, or plot;
- any other information or instructions required for production.

It is clear that there are numerous types of information required. Likewise, there are different types of production resources and manufacturing control systems that require information, including: automated machines, human workers and operators, schedulers and/or scheduling software, inventory controllers, and many others. Each type of production resource or system requires different types of information.

### **5.3.4 Approaches to CAPP**

There are two types of computer aided process planning: variant and generative. Variant process planning (VPP) is an approach that utilizes several “base plans” that are modified based on design data. Once an appropriate base plan is chosen and retrieved from a range of available plans, characteristics of the desired component, such as dimensions, material type, required finish quality, etc., are extracted from the design either manually or automatically. The base plan is then modified for the specific component and the process plan is generated. VPP is useful because it is simpler and easier to implement than the generative approach. VPP systems are most suited to part families, or groups of products that share similar manufacturing requirements.

Generative process planning (GPP) differs in that no base plans are utilized. Instead, each plan is generated by using rules, algorithms, and/or knowledge based techniques. GPP is useful in cases where base process plans cannot be predefined such as when the product variety is too great. Whereas knowledge is captured in VPP in the form of a database of base plans, in GPP knowledge is captured in the form of processing rules.<sup>42</sup> These rules are often represented in the form of decision trees. GPP systems are well suited to part

---

<sup>42</sup> Nolen, James, *Computer-Automated Process Planning for World-Class Manufacturing*, Marcel Dekker, Inc., New York, 1989.

families with an identifiable set of features for which consistent manufacturing rules have been developed.

The important and useful knowledge domains are the process knowledge base, which is a function of the processes used in production, and product knowledge, which is extracted from the design. Because of the inherent complexity of systems relying on artificial intelligence, generative process planning systems are more difficult and more costly to develop than variant process planning systems. However, generative process planning systems can usually handle a greater variety of parts than variant process planning systems, which are restricted to variations of the base plans.

The basic requirements for CAPP are a scheme or structure for representing data and a feature extraction or interpretation engine which generates a plan from the representation. However, CAPP system architecture, data flow, and the general approach to automated planning are still research topics. Bowden and Browne present an approach for robotic assembly planning based on interactive, computer *aided* planning, with only certain tasks *automated*.<sup>43</sup> The system utilizes industry specific assembly operations and robot assembly rules to aid the process designer. For example, in choosing a robot for a task, the system narrows the search by eliminating many robots based on the ability of the robot to meet technical criteria (accuracy, repeatability, payload, etc.). The final choice is the responsibility of the human planner and is based on the layout of the assembly cell.

It should be noted that process plans are usually not machine specific. Post processors are used to generate the machine specific part programs from the process plans. (See Section 5.3.6.5)

### **5.3.5 Group Technology (GT)**

Group technology is “the identification of subsets or families of similar products within the population at large for the purpose of design and manufacturing efficiencies through consistent application of ‘best practice’ technology to the characteristic attributes of the family.”<sup>44</sup> In other words, GT assumes that products can be grouped into subgroups in such a way that we can apply generalizations about how all the products in the subgroup are made. The most common way to classify parts is by defining relevant attributes based on manufacturing requirements.

GT also implies that there are optimal production procedures that can be specified for each subgroup. In manufacturing, parts can be made by many different sequences of tasks.

---

<sup>43</sup> Bowden, R. and J. Browne, "ROBEX - An Artificial Intelligence Based Process Planning System for Robotic Assembly." *Proceedings of the IXth International Conference on Production Research*, 1987.

<sup>44</sup> Nolen, James, *Computer-Automated Process Planning for World-Class Manufacturing*, Marcel Dekker, Inc., New York, 1989.



Nolen states that for a family of one hundred similar parts, there may be seventy or eighty different part routings, and as a result, standard cost and labor standards may differ by a factor of five or ten for identical features.<sup>45</sup>

GT and VPP follow essentially the same approach. With GT systems, the design problem is to develop a base plan and rules or procedures for modifying the base plans based on the representation. GT code was one of the first methods used to represent product data for CAPP. However, it was not a rich enough structure to represent all the information required for CAPP applications.<sup>46</sup>

### **5.3.6 Planning Levels / Integration**

There are three levels of process planning and control: machine level, task level, and production level.

#### *5.3.6.1 Machine Level Control*

The lowest level of control is the machine level. Machine level control is concerned with controlling the relative positions and motions of the machine tool, manipulator, and/or work piece to ensure a desired result. Thus, the basic function of machine level control is the servo-control of actuators and motors. Electronics and modern control theory provide mechanical engineers with the tools necessary for designing closed loop control systems for this level of control. For example, a closed loop controller can be designed to ensure positional accuracy of a milling machine axis through closed loop control of its drive motor. Programmable logic controllers, or PLC's, are commercially available low level control interfaces.

However, while position control is primarily closed loop, the actual process that is being performed by the machine is often controlled open loop. For example, in metal cutting, the correct position and feed rate may be controlled closed loop, but the cutting process (chip formation, cutting force, temperature of the workpiece, etc.) is not monitored. A more complex form of machine level control is found with adaptive control systems, which take the notion of machine level control one step further. Adaptive control systems "close the loop" on the process as well. For example, a adaptive controller might vary the feed rate in response to force feedback.

There are two primary types of adaptive control systems: adaptive control with constraints (ACC) and adaptive control optimization (ACO). ACC controllers modify process settings in response to changes in the process to maintain one process state variable at some

---

<sup>45</sup> Nolen, James, *Computer-Automated Process Planning for World-Class Manufacturing*, Marcel Dekker, Inc., New York, 1989.

<sup>46</sup> Wang, H.-P. Ben, L.-H. Qiao, and C. Zhang, "Integration of PDES/STEP and CAPP," *Autofact '92 Conference Proceedings*, 1992.

prescribed, optimal value. ACO systems are more complex than ACC systems, containing an explicit model of the process which is optimized in real time. Adaptive controllers have been developed for a variety of processes. ACC systems are commercially available for some machining operations, but they have not yet achieved widespread use due to poor performance. Adaptive control systems are still somewhat experimental.

#### *5.3.6.2 Task Level Planning*

The next level of planning and control, called task level planning, is responsible for planning the machine motions (and/or manual processes) necessary to complete a specific task. For example, to insert part A into the hole in part B, the following tasks might need to be performed: grasp part A with gripper, move to position one above part B, and move vertically downward to position two.

Task level planning can be divided into two primary operations: process planning and part programming. Process planning refers to the development of the logical steps required to perform a series of operations, including choosing the types of machines and tools to be used in the operations. Part programming refers to the generation of machine readable numerical control information from the process plan. It is for task level planning that computer aided process planning (CAPP) has been developed.

#### *5.3.6.3 Production Level Control*

The highest level of control is production level control. Production control is concerned with managerial issues such as machine and batch scheduling, inventory management, etc. The objective is to plan and schedule operations to accomplish a set of goals in the most efficient manner. These problems can be solved using operations management techniques. The production planner utilizes knowledge about the available production equipment (cycle times, machine reliabilities, tolerance capabilities, costs, labor requirements, etc.), knowledge about the availability of constrained resources (time, manpower, machine time, money, etc.), and a set of production goals, and determines the optimal mix of resources for the most efficient production.

There are many computer based tools available for aiding in planning production flow and scheduling, including MRP (material requirements planning), MRPII (manufacturing resource planning), queuing theory, linear programming, shop floor control systems, and manufacturing execution systems.<sup>47</sup> These may be considered push or pull systems. In either case, the objective is to minimize inventory without interrupting or delaying the production and delivery of products to customers.

---

<sup>47</sup> Marks, Peter, Editor. *Process Reengineering and the New Manufacturing Enterprise Wheel: 15 Processes for Competitive Advantage*, Society of Manufacturing Engineers Blue Book Series, Dearborn, Michigan, 1994.

#### 5.3.6.4 CAPP Integration

CAPP systems typically perform task level planning. However, they often must interface with high level planning systems such as MRPII and low level controls for factory automation such as numerical controllers or programmable logic controllers.

An MRPII system controls scheduling factory wide. To perform scheduling, MRP systems need a detailed bill of materials, task sequences for each part, routing information, and time standards for each task.<sup>48</sup> The argument for integrating MRP scheduling and CAPP task/resource generation is that the plan may have to be modified based on unforeseen scheduling conflicts, machine downtime, etc. In some production environments, such as machining, this is possible since different processes can often be used to accomplish the same task. While the process plan would specify the optimal process, a less efficient process might be favored over waiting for the availability of the more efficient resource.

Systems have been developed for real time scheduling. One system for real time dynamic scheduling of flexible assembly lines is capable of routing the part through the assembly process without a predefined routing.<sup>49</sup> The system utilizes DeFazio and Whitney's work on generating assembly plans.<sup>50</sup> It assumes that the material transport system and palletizing is capable of routing materials between any node, so-called "free transfer technology." In addition, it assumes the manipulators are flexible enough that an operation can occur at many of the cells and it assumes component parts are available at numerous cells. The idea is that the system is capable of robust performance and can respond to perturbations in the system such as machine failures.

#### 5.3.6.5 Post Processors

CNC path planning can be performed with a post processor, as described in the examples above. Such a post processor or plan compiler uses the outputs of a CAPP system as its inputs, including: sequence of operations, machine types, raw material dimensions and positions, nominal part dimensions, stock removal rates for each cut, cutting directions, and others. The system then generates the specific "traverse function codes" (G-codes) and "miscellaneous function codes" (M-codes) required to control a specific machine. Different CNC machines sometimes use different G-codes and M-codes for the same

---

<sup>48</sup> Nordland, Gerald L., "Integrating CAPP into Factory Management Systems," *Manufacturing Systems*, February, 1985.

<sup>49</sup> Bourrieres, J. P., O. K. Shin, and F. Lhote, "Real-Time Production Scheduling and Dynamic Parts Routing for Flexible Assembly Lines," *International Journal of Systems Automation: Research and Applications (SARA)* Volume 1, Number 4, 1991.

<sup>50</sup> De Fazio, Thomas L., and Daniel E. Whitney, "Simplified Generation of all Mechanical Assembly Sequences," *IEEE Journal of Robotics and Automation*, Vol. RA-3, No. 6, December, 1987.

cutting function.<sup>51</sup> Such plan generation is fairly simple given the input information and the output language.

In the future, post processors (defined by one author as “not elegant”) may not be necessary. System developers are attempting to move toward open system machine tools, in which machine hardware would be controlled by a standard PC computer and machines would communicate through industry standard communication networks. One early attempt at protocol development was by General Motors with their MAP (manufacturing automation protocol) project.<sup>52</sup> <sup>53</sup> Reportedly, the protocol was too limited to respond to unexpected situations.

## 5.4 Summary

FMS/CIM technologies decrease the cost and time of producing a range of products. Essentially, the minimum batch size that can be economically produced is reduced by the elimination of pre-production costs associated with process design, retooling, and process planning. Thus, flexible manufacturing systems stimulate product variety and complexity by providing these capabilities. Although the potential economic gains from increasing machine size, speed or accuracy seem of decreasing significance, the potential economic gains from flexible, programmable automation are just beginning.<sup>54</sup>

There are numerous operational, organizational, and strategic advantages of flexible manufacturing systems compared to rigid mass production, but perhaps the largest source of advantage has only begun to be tapped. The application of FMS and CIM technologies to batch production, where automation has yet to be successfully applied, has the potential for further dramatic improvements in productivity, quality, and time — without sacrificing flexibility. With FMS, the tradeoff of flexibility for efficiency, which has prohibited the application of automation to batch production, has been largely eliminated.

---

<sup>51</sup> Shy, L., C.Y. Kao, S.T. Hsieh, C.M. Chen, N.H. Madsen, and R.E. Beckett, “Flexible Post-Processor for Process Planning Program,” *Proceedings of Manufacturing International 90*, Vol. I, 1990.

<sup>52</sup> Wright, P.K., and I. Greenfeld, “Open Architecture Manufacturing: The Impact of Open-System Computers on Self-Sustaining Machinery and the Machine Tool Industry,” *Proceedings of Manufacturing International 90*, Vol. II, 1990.

<sup>53</sup> Pye, Colin, *What is MAP?* NCC Publications, Manchester, England, 1988.

<sup>54</sup> Ayres, R. U., R. Dobrinsky, W. Haywood, K. Uno, and E. Zuscovitch, *Computer Integrated Manufacturing, Volume IV: Economic and Social Impacts*, Chapman & Hall, London, 1992.

FMS/CIM does not necessarily require fully automated material processes. Much of the benefit is realized via the automation of information processes through design-manufacturing integration and automated process planning. CAPP is applicable to job shops and batch processes which have domains that can be constrained enough to be modeled. Where it can be applied, it provides numerous benefits, including:

- reduced time and cost of generating process plans;
- the elimination of mistakes in process plans;
- consistency of process plans;
- potential for generation of optimal process plans;
- a decrease in the product development cycle time;
- reduced requirement for hard-to-find skillful process planners
- elimination of design errors (when integrated with design)

CAPP systems must integrate with many different types of production resources and manufacturing control systems, including: automated machines, human workers, and other software. Thus, they are required to generate numerous types of information and must communicate that information in many forms.

Variant process planning is one approach to CAPP in which a range of available process plans are modified based on design data. VPP is simpler and easier to implement than generative process planning. VPP systems are most suited to part families, or groups of products that share similar manufacturing requirements.

In summary, there are numerous technologies that have been developed to increase flexibility in manufacturing. It is reasonable to conclude that production flexibility can be achieved without detrimental effects on cost, quality, or time. In fact, an increase in flexibility (and the organizational and operational changes that accompany it) often reduces costs, increases quality, and reduces time.

## 6. Flexible Manufacturing Systems for Off-site Production in Homebuilding

Chapter Four described the technologies currently being used in the off-site production of components for the housing industry. In Chapter Five, the state of the art in computer integrated manufacturing was presented. This Chapter identifies specific areas of overlap, in which flexible manufacturing technologies might be applied in off-site production. It describes how the adoption of such technologies can benefit the housing industry. In addition, it shows how the adoption of such technologies is consistent with the current best thinking in construction automation research, which was introduced in Section 1.2.

### 6.1 Benefits of Automation in Construction

Automation has provided numerous benefits in industries that have adopted it, including: raising productivity, speeding production, increasing quality, and providing new production capabilities. This Section describes the potential benefits of applying flexible manufacturing system technologies to off-site processes in the housing industry.

#### 6.1.1 Increased Quality

Quality means different things to different people. Garvin captures this multidimensional nature of quality when he describes it in terms of eight attributes.<sup>1</sup> According to Garvin, the eight dimensions of quality are: performance, features, reliability, conformance, durability, serviceability, aesthetics, and perceived quality. These dimensions represent product quality well and are useful for competitive benchmarking of products. However, to evaluate production technologies and processes, it is necessary to gain a sense of why certain products are able to score highly on such quality measures. Chryssolouris addresses this when he states that quality, as it relates to customer satisfaction, can be traced to both the design and the manufacture of a product.<sup>2</sup> Accuracy, repeatability, surface finish, and tolerance are some of the measures used to represent the potential quality or capabilities of a manufacturing system. Automated equipment and flexible manufacturing systems score higher than systems that rely on manual processes on these measures of *manufacturing* quality.

Mechanized processes are simply more accurate and more repeatable than manual processes. Accuracy refers to how small of an absolute tolerance the system can achieve. Automated positioning allows mechanized processes to be more accurate. Better accuracy

---

<sup>1</sup> Garvin, David A., "Competing on the Eight Dimensions of Quality," *Harvard Business Review*, November-December, 1987, pp. 101-109.

<sup>2</sup> Chryssolouris, George, *Manufacturing Systems*, Springer-Verlag, New York, 1992.

allows parts to fit better in assembled products. A better fit results in less wear for moving parts that are in contact with one another, which translates into improved long term *durability* (one of Garvin's quality dimensions) of the product. Repeatability, which is also better in mechanized processes than manual production, refers to the variation from piece to piece. Repeatable processes allow predictable quality levels to be maintained over time and minimize or eliminate non-conforming (scrap) parts.

In homebuilding, off-site process automation will give rise to better dimensional accuracy of components and assemblies and better consistency of work (reducing rework and material waste). For example, firms that have adopted automated saws for truss manufacturing report better fitting connections. Likewise, the automated removal of defects (knots) in lumber being processed for window manufacturing has resulted in a four percent increase in material yield (a reduction in material waste from fourteen percent to ten percent).

In on-site construction, quality is usually measured in terms of defects in product performance or workmanship. According to a recent survey by the National Association of Homebuilders and *Builder* magazine, eight-five percent of builders spend up to five hundred dollars per house on call-backs (rework to correct defective work).<sup>3</sup> Moving more of production off-site offers opportunities to improve quality through better control of environmental conditions, closer process control, and facilitated inspection, so these quality-related costs should fall.

### **6.1.2 Decreased Time**

Automated production reduces manufacturing time in several ways. First, machines decrease the time needed for individual production tasks because they can simply perform motions faster than a person. Second, because machines can run continuously, machines eliminate wasted time and/or resting time. Thus, the cycle time of the system is reduced.

Third, just-in-time flexible production reduces overall system throughput time by reducing the time materials spend in queues. Until recently, products have been mass-produced and inventoried. Although parts are made quickly, they accrue inventory storage time prior to, during, and after being processed. As a result, the overall time from material to finished product, called the throughput time, is usually not short for automated mass production systems. On the other hand, the fast, flexible production technologies of mass-customization have created a trend toward just-in-time production and the delivery of made-to-order products. Thus, flexible manufacturing systems also decrease the overall system throughput time.

In homebuilding and components production, automation can result in both reductions in cycle time and reductions in throughput time. For example, the machines described in

---

<sup>3</sup> Binsacca, Richard, "10 Steps to Zero Defects," *Builder*, June, 1991.

Section 6.1.1 that were responsible for decreasing material waste also increased processing speed (cycle time) by 250 percent. Likewise, the automated saws used in truss manufacturing increase daily production. The adoption of flexible manufacturing systems can be expected to decrease overall throughput time as well, by eliminating finished goods inventory.

### 6.1.3 Economics of Flexibility and Variety

Flexible manufacturing systems *allow* a manufacturer to economically produce a greater number of products, options, or varieties than a traditional manufacturer. While this is an easily understood and accepted concept, it can also be shown both analytically and graphically that a manufacturer *must* produce a greater number of products, options, or varieties if economically optimal production is to be maintained.

Total unit costs of production are composed of costs that vary with volume (scale related costs) and costs that vary with variety (flexibility related costs). Scale related costs fall as production volume increases for both flexible and traditional factories, typically by fifteen to twenty-five percent for each doubling of volume.<sup>4</sup> In a traditional factory, flexibility related costs rise as variety increases, usually by twenty to thirty-five percent for each doubling in variety. In flexible factories, however, variety related costs rise more slowly.

$$ScaleCost = BaseScaleCost(1 - DecayRate)^{\frac{\log(Volume / BaseVolume)}{\log(2)}}$$

#### Equation 6-1: Scale Related Cost Function

Analytically, we can express the declining scale-related cost function as shown in Equation 6-1. The scale cost is the product of some baseline cost and a decay function which decreases by a fixed percentage for each doubling of volume. Likewise, the increasing flexibility-related cost function, as shown in Equation 6-2, is the product of a baseline flexibility cost and a growth function which increases by a fixed percentage for each doubling of volume. The total unit cost is simply the sum of these scale and flexibility cost functions.

$$FlexibilityCost = BaseFlexibilityCost(1 + GrowthRate)^{\frac{\log(Volume / BaseVolume)}{\log(2)}}$$

#### Equation 6-2: Flexibility Related Cost Function

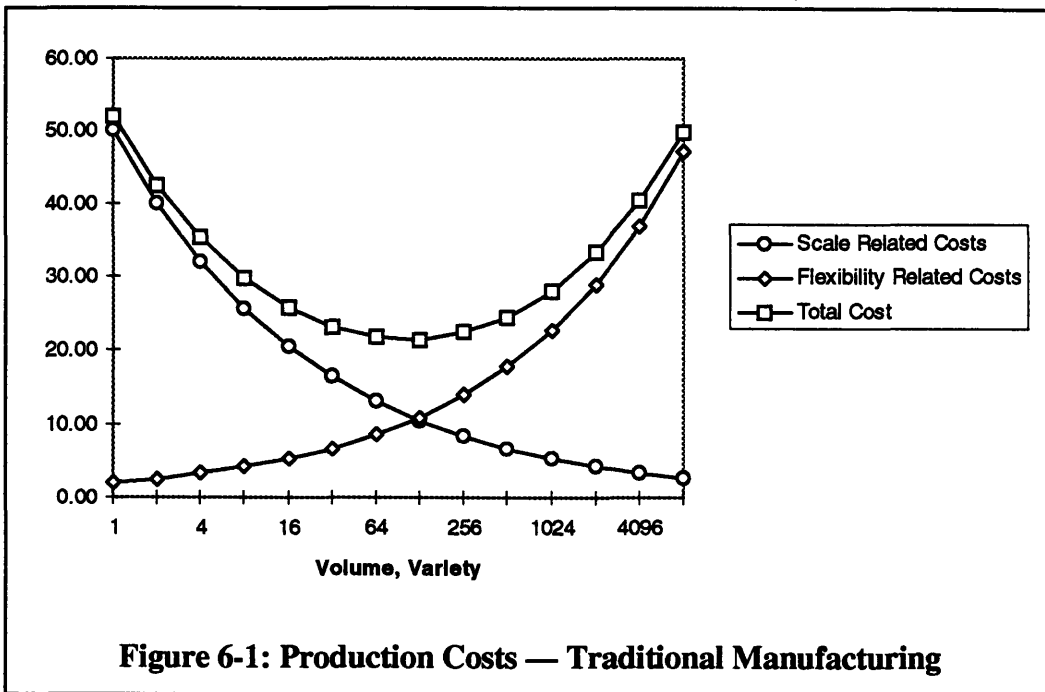
Figure 6-1 (adapted from Stalk) shows a graph of production costs for a traditional manufacturing plant. The scale related costs are assumed to fall by twenty percent for each doubling of volume. Flexibility related costs are assumed to rise by 27.5 percent for

---

<sup>4</sup> Stalk, George, Jr., "Time – The Next Source of Competitive Advantage," *Harvard Business Review*, July-August, 1988, pp. 41-51.

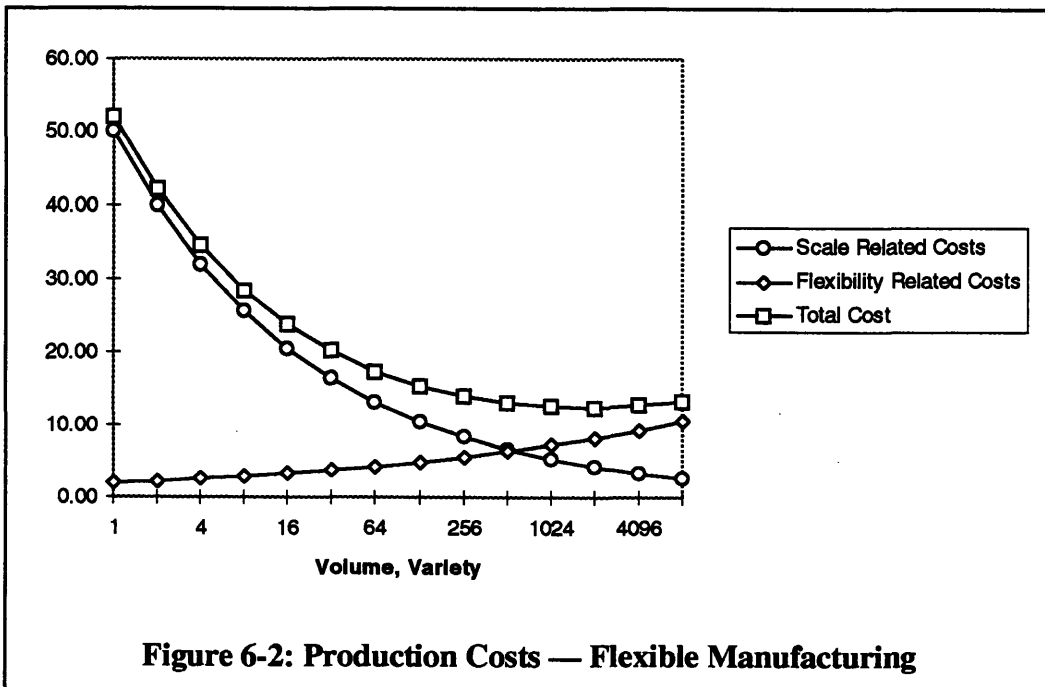


each doubling of volume. These numbers represent the average growth and decay rates that were quoted by Stalk. For this case, the optimum point of production occurs for a volume/variety of 128.



**Figure 6-1: Production Costs — Traditional Manufacturing**

In Figure 6-2, the same curve is used to represent scale related costs. However, the flexibility related costs are assumed to increase only fifty percent as fast as in Figure 6-1. The result is that the optimum point of production occurs for at a much higher volume/variety of 2,048. In addition, the total unit cost is lower at the optimum production volume/variety.



**Figure 6-2: Production Costs — Flexible Manufacturing**

Thus, it is shown that given a traditional factory and a flexible factory with identical scale related costs, the optimum cost point (representing the minimum total unit cost) for a flexible factory is lower in magnitude and occurs at a greater variety and volume than for a traditional factory.

#### **6.1.4 Better Jobs**

The Department of Labor has projected a shrinking pool of labor in coming years, an increase in the average age of the workforce, and a decrease in the number of people interested in construction careers. Off-site automation can help alleviate the potential lack of labor in two ways. First, since automated production increases labor productivity, it can often be maintained in spite of scarce or unavailable labor. In addition, productivity improvements will increase the capabilities of the remaining workforce and raise potential wages. Thus, more workers may be attracted to the positions.

The purpose of automation should not be to eliminate workers, but to create highly productive, highly paid, enjoyable jobs for workers. Boring, repetitive tasks and heavy manual tasks can be automated, relieving workers from such unfulfilling jobs. For example, an additional benefit of the automated defect removal machines described in Section 6.1.1 is that workers are required to do less manual lifting.

In addition, safety can be enhanced by using robotics and automation to perform tasks in hazardous environments. In off-site production of housing, the construction of roofing assemblies, overhead installation of components, and other tasks can be dangerous. Automation of these tasks will result in safer jobs in housing construction and components manufacturing.

#### **6.1.5 Increased Capabilities**

Automation increases and enhances the capabilities of production systems. Tasks that were impossible to accomplish by hand, such as tasks requiring fine positioning accuracy or tasks requiring specialized equipment, are made possible through mechanization.

For example, energy efficient windows and doors, which have dramatically improved the quality of housing, require factory controlled production conditions. It is not possible to apply low-E coatings to glass on-site, nor is it possible to maintain the weather-tight connections of today's windows and doors using on-site techniques. Likewise, trusses cannot be fabricated efficiently on the site. They require accurate cuts to maintain quality and specialized equipment to apply the truss plates. As more operations are performed off-site, production capabilities will increase due to the increased ability to utilize sophisticated production resources.

### 6.1.6 Strategic Benefits

Porter states that “of all the things that can change the rules of competition, technological change is among the most prominent.”<sup>5</sup> If we assume that the operational benefits that are described in this section and elsewhere can be economically achieved, then it is likely that there will be significant short-term and long-term strategic effects both at the firm level and industry wide.

In the short term, firms that adopt the technology are likely to capture a significant competitive advantage. According to Porter, “Technology affects competitive advantage if it has a significant role in determining relative cost position or differentiation.”<sup>6</sup> Flexible manufacturing systems decrease the cost of differentiation by allowing customized products to be made quickly and efficiently. It is unlikely that firms that do not adopt the technologies will be able to compete.

In addition, first movers may gain a significant sustainable advantage. The production technology itself, if it is proprietary or protected by patents, may act as a barrier to entry to potential competitors. Whether or not it is proprietary, the learning curve associated with the new production technology will favor early adopters. It may also be too difficult for some firms to duplicate the organizational changes necessary to adopt the technologies.

In the long term, many firms may exit the industry. In fact, since exit barriers are so low, there should be relatively little effective resistance from non-competitive firms in the industry. The firms that remain, however, are likely to be more profitable than prior to the adoption of the technology.

Porter states that the profitability of an industry is determined by the relative strength of five market forces: the threat of new entrants, the bargaining power of suppliers, the bargaining power of buyers, the threat of substitute products, and the rivalry among existing firms.<sup>7</sup> It is possible that the long-term profitability of the housing industry and/or its suppliers will increase since the threat of new entrants will be reduced by higher barriers to entry. Flexible manufacturing systems and off-site production will increase barriers to entry in several ways. Economies of scale will be created. Today, there are virtually no production economies of scale in the on-site industry. In fact, the minimum efficient scale of production is very low, on the order of one. In contrast, the minimum

---

<sup>5</sup> Porter, Michael E., *Competitive Advantage*, The Free Press (Macmillan Publishing) New York, 1985.

<sup>6</sup> Porter, Michael E., *Competitive Advantage*, The Free Press (Macmillan Publishing) New York, 1985.

<sup>7</sup> Porter, Michael E., *Competitive Strategy*, The Free Press (Macmillan Publishing) New York, 1980.

efficient scale in the automotive industry is roughly two hundred thousand units per year. In addition, economies of vertical integration may become important. For example, a large off-site producer may purchase materials directly from the source, eliminating the overhead and markup of the distributor and the local building supply store. New flexible manufacturing systems will require sources of capital that are simply beyond the traditional homebuilder, who is used to operating from the back of a pickup truck.

The market for homes is a very mature market. New home sales are relative constant in the long term, although they fluctuate in the short term due to macroeconomic conditions. Characteristic of mature markets, homebuilders differentiate their products on the basis of cost and features. Low cost producers have a distinct advantage. Customers are extremely price sensitive. Once the new market structure is established, the off-site producer can differentiate the product on the basis of design features and/or quality, and can create brand loyalty among buyers. Architects have attempted to do this with their design services. By avoiding price competition and by prohibiting new entrants to the industry, profitability may increase.

### **6.1.7 Flexibility and Reduced Effects of Demand Cyclicity**

In response to cyclical demand, a manufacturer or homebuilder has several options:

- The firm can accept the cyclicity of demand as an uncontrollable phenomenon and produce products for the cyclical market using factor inputs that are non-specialized. An example of this is a builder that uses subcontracted labor that also does work for other contractors, remodeling work, and/or repair work. The advantage of this approach is that the inputs are only paid for when needed. The disadvantage of this approach is that productivity is lower than it would be if inputs were dedicated and specialized because systems with dedicated resources such as long time employees, equipment, and other fixed production assets tend to have higher productivity than non-specialized resources.
- The firm can attempt to stabilize the demand for its factor inputs by producing a non-specialized product that can serve several substitute markets. An example of this is a mass-producer of windows, which attempts to market the same line of windows to new construction and to the remodeling market. This option is preferable to the first option since it saves the cost of inter-firm sharing of resources (extra layers of management, communication and coordination costs, etc.). However, for homebuilders, the choice of substitute markets is somewhat limited. In addition, the value of the non-specialized product will probably be lower than it would be if it were tailored to each market.
- The third approach is for the firm to attempt to stabilize the demand for its factor inputs by producing several diversified products with the same resources. Each product is specialized for its particular substitute market. This option is preferable to option two since the value of each specialized product should be greater than that of non-specialized products. However, in the case of a manufactured product, the

required flexibility of the production resources is usually much higher. Flexible manufacturing systems will help allow firms to stabilize demand in this way. For example, a kitchen cabinet manufacturer who shifts from a rigid (mass) production system to a flexible manufacturing system would be capable of producing custom, made-to-fit cabinets for the remodeling market, which tends to be approximately counter-cyclical with new construction. Off-site homebuilders could potentially diversify between several market segments in addition to geographic diversification, by producing high and low priced homes and commercial modular structures with the same production resources.

In essence, flexible manufacturing system technology helps offset the cyclical demand problem in two ways: the inherent flexibility enhances a firm's ability to diversify into other products and/or counter-cyclical markets using the same production resources; and, the lower cost of automated production should also increase the geographic range that products can be economically shipped to, thus enhancing geographic diversification.

## **6.2 Past Approaches to Construction Automation**

Although automation and robotics has infiltrated numerous industries in the United States and abroad, it has yet to see any widespread use in the construction industry. As was discussed briefly in Chapter 1, automation and robotics have been focal points of research and development activities in construction over the past decade, and have been touted as technologies with the potential to revolutionize the industry. The results, in terms of actual impacts on the industry, have for the most part been disappointing, since very little has changed in the way construction operations are actually performed on-site. This section presents reasons why the approaches to system development in recent years may have been misdirected, and presents the approach of off-site flexible automation. The promise of off-site flexible automation is the realization of the benefits described in Section 6.1.

### **6.2.1 On-Site Automation**

There have been two primary approaches to research and development in construction automation. The approach taken by most researchers has been to build complex, expensive, automated systems for on-site operation. In fact, numerous experimental systems have been developed — primarily at universities. However, virtually none of the systems have generated widespread interest among contractors beyond the curiosity stage.

The systems are meant to duplicate the efforts of the worker, thus reducing labor costs, but have proven impractical. One reason is that construction techniques have developed over thousands of years to optimize the ability of a human worker. The task of building a machine with human capabilities is extremely difficult, and is beyond the reach of today's technology. Therefore, such systems inevitably perform unsatisfactorily and are too costly.

Research has shown that difficulties also arise as a result of fundamental differences between the production processes involved in construction and manufacturing. In construction, the batch size is one (unique products), while in manufacturing, batch sizes

are typically on the order of tens, hundreds, or thousands. Construction operations are site specific, while in a factory environment, operations for identical products are identical. The on-site construction environment is also more complex than a factory environment and is constantly changing. Construction processes occur at multiple locations throughout the site, so mobility is required. Since the product is large and fixed, the machine must go to the work, rather than the work going to the machine, as in a factory. Weather also impacts construction operations.<sup>8</sup> In on-site construction, mobility, space, and access are limited, while a factory is designed to provide adequate space. Such a complex, dynamic environment demands that site-based automated systems have vision and sensing systems that are at the forefront of today's technological capabilities. These inherent differences between construction and manufacturing processes also cause on-site automated systems to be complex and expensive, and thus to provide less than stellar performances.

The second approach to construction automation has been to integrate workers and machines in a system which allows each to do suitable portions of the task. In other words, the systems are designed to match the mechanical capabilities of machines with the skills and sensory abilities of human workers. This approach is logically sound, but since the scope of such systems is much narrower, the resulting improvements are incremental in nature. However, to achieve these slight improvements, the industry's inertia against change must be overcome and workers must be retrained and convinced to use the new technology. Although this approach to construction automation is more tractable (and is the most practical approach for on-site automation), only relatively small advances are possible.

### **6.2.2 Off-Site Flexible Automation**

A better approach to construction automation would be to combine automated, off-site production with on-site installation. Such an approach neutralizes the problems with the inherent nature of construction by moving much of the work off-site to a controlled environment. It also allows design for assembly to be rationally applied to a component or subsystem slated for off-site production. In addition, construction automation researchers can take advantage of the existing body of research on factory automation. In other words, instead of adapting current automation technologies to on-site construction, it is better and more efficient to move some construction operations to the manufacturing realm, where automation technology is already well developed and "fits" well with environmental conditions and organizational structures.

Demsetz also suggested that there are two approaches to overcoming the complexities of the jobsite: move production to a factory or factory-like environment; and focus on semi-

---

<sup>8</sup>Vallings, H.G. *Mechanization in Building*, Applied Science Publishers, London, 1975

automated systems, the “smart tools” approach.<sup>9</sup> However, the two approaches are not interchangeable. Certain tasks are well suited to off-site production, while others must be performed on site. Each approach is optimal for different processes and tasks. In fact, when used together they compliment each other symbiotically. Off-site produced components and subassemblies are more competitive when efficient tools are available for installation, and “smart tools” are even “smarter” when they are installing highly complete, high value-added components.

Under this new approach, on-site building operations (excluding site work) need only to concentrate on tasks associated with final assembly, lifting, fastening, and finishing, since materials manufacturing, preparation, and primary assembly will have already been performed off-site.

### **6.2.3 Off-site Production Operations — Beyond Modularization**

Previous attempts have been made to move substantial portions of construction work off-site, especially in the housing industry. The pervasive approach has been the redesign of the product to maximize the capabilities of mass production technologies. These proposed systems emphasized modularization of components to enable the production of a variety of designs with a few standardized, mass-produced shapes. The classic example from homebuilding is the so-called “systems builders” of the Operation Breakthrough era. A significant reason why this approach failed is that it simply could not provide the flexibility needed in homebuilding.

Today, off-site operations are not restricted to standardized or modularized components that utilize mass production techniques. Rather, the product can be redesigned for ease of assembly and can utilize the inherently flexible lean production techniques.<sup>10</sup> The technology of lean production is embodied in flexible manufacturing systems, rather than the dedicated assembly lines of mass production. Traditionally, manufactured products were either manually produced in small batches or mass produced in huge batches. Today, flexible manufacturing systems have enabled the economic, automated production of small to medium sized batches of products. Batch sizes on the order of one or ten can be economically produced with the new systems.

---

<sup>9</sup> Demsetz, Laura Ann, “Task Identification and Machine Design for Construction Automation,” Massachusetts Institute of Technology Department of Civil Engineering, Ph.D. Dissertation, 1989.

<sup>10</sup> For an introduction to lean production techniques, the reader is referred to Womack, James P., Daniel T. Jones, and Daniel Roos, *The Machine That Changed The World*, Rawson Associates, New York, 1990.

## **6.2.4 On-Site Assembly Operations**

On-site construction consists essentially of assembly operations. Since preliminary assembly of subcomponents can be accomplished off-site, on-site operations (exclusive of site work) will consist of tasks such as final assembly, installation, lifting, fastening, and finishing. Efficient tools can be developed to aid the worker in these tasks. Workers and machines can be integrated in a system which allows each to do suitable portions of the task. In other words, the mechanical capabilities of machines can be matched with the skills and sensory abilities of human workers.

The “smart tools” approach has resulted in some successful automated systems for on-site construction. Examples include partially automated grading, [Tatum and Funke, 1988], and the Cranium.<sup>11</sup> Partially automated grading combines automated control of the elevation of the grader blade with the superior navigational abilities of the human, and has been successfully used on sites. The Cranium augments the vision capabilities of the human crane operator to improve crane safety and increase productivity. While not yet used on jobsites, a prototype Cranium has received rave reviews from crane operators, signaling probable adoption in the near future.

## **6.3 Applications of the Off-Site Approach in Housing**

There are three possible scenarios in which flexible manufacturing system technologies can be applied to off-site production in the housing industry:

- the flexible production of mass produced materials and components;
- the automation of the information processing components of manual production operations;
- the automation of the material processing components of manual production operations.

### **6.3.1 Flexible Production of Mass Produced Materials and Components**

As was discussed in Chapter Three, many of the materials and components used in housing are mass-produced. In this scenario, some of the rigid mass-production equipment is replaced by flexible, computer controlled equipment. If customization provides additional value to customers, then suppliers can potentially capture the strategic and operational benefits mentioned earlier.

The nature of the products to which this scenario would apply can be determined by an analysis of the input-output tables of construction, as described in Chapter Two. A subset

---

<sup>11</sup> Everett, John G., “Construction Automation: Basic Task Selection and Development of the CRANIUM,” Massachusetts Institute of Technology, Department of Civil Engineering, Ph.D. Dissertation, 1991.



of the complete input-output table for the 1982 year is shown in Table 6-1 (recompiled from Table 2-4 with non-material items and items contributing one percent or less to total value excluded). Table 6-1 shows the top eight construction material inputs for single family residential new construction, totaling 18.7 percent of overall inputs to housing.

<b>Input Category</b>	<b>% of Total Value</b>
General Sawmills and Planing Mills	5.0%
Ready-mixed Concrete	4.0%
Millwork	3.0%
Veneer and Plywood	1.7%
Wood Kitchen Cabinets	1.5%
Metal Doors, Sash, and Trim	1.3%
Prefabricated Wood Buildings	1.2%
Floor Coverings	1.0%

**Table 6-1: Top Material Inputs, 1982**

With the exception of prefabricated wood buildings, many of the products represented by these categories are produced using mechanized, if not fully automated production equipment. Those products that are more valuable in custom configurations may benefit from a shift to more flexible manufacturing equipment. For example, lumber could be ordered in custom lengths or sizes. Also, customized windows, doors, and cabinets could begin to capture a greater share of their respective markets.

### **6.3.2 Automated Information Processing with Manual Production**

A flexible manufacturing system is flexible essentially because the information processing components of the tasks are automated in addition to the material processing components. In fact, the primary difference between FMS and mass production is its ability to use instance-specific information in production.

However, there is no requirement that a flexible manufacturing system have automated material processing capabilities. Simply automating the information processing components of tasks will increase task flexibility and efficiency by eliminating manual process planning. In this scenario, manual tasks are made more flexible through the automation of information processing.

This scenario results in the creation of an information infrastructure which supports flexibility throughout the production system. In this scenario, information flows seamlessly throughout the factory, providing the instance-specific information required for flexible production. The information is simply presented in a form most useful to the recipient — whether human or machine.

One example from window manufacturing is the sorting of special glass pieces when they exit the cutting machine (see Section 7.4.3.1). Sorting is performed manually, but a graphical computer display connected to the process controller automatically provides the necessary information to the worker. Other applications include the automatic generation and distribution of electronic information to islands of automation and to manufacturing control systems.

### **6.3.3 Automated Material Processing**

Many operations that are now performed off-site are performed manually using batch production (general purpose, non-automated tools, etc.). These include fabrication and assembly of components, as well as most of industrialized housing's production and assembly operations. With flexible manufacturing systems, some of these manual tasks can be automated, and the benefits described in Section 6.1 can be achieved.

Once an information infrastructure has been created, as described in Section 6.3.2, it will be easier to develop and implement such systems. It will be easier and less expensive because a portion of the system, the automatic generation of process information, will already be completed. The information must simply be formatted for use by the cell controller. This can be accomplished via a post-processor.

It is possible to automate virtually all off-site construction operations. However, the cost to automate the operations with fixed automation is not justified based on the production volume. However, with flexible automation that is capable of producing numerous different products, the minimum production volume per product is reduced. Thus, more off-site operations can potentially be automated.

In addition, some operations that are now performed manually on-site may be shifted off-site, where flexible automation can provide the benefits mentioned above. In other words, the balance of forces which determines the most efficient (cost minimizing) location for production tasks will shift in the direction of off-site production, where the new flexible automated production resources can be brought to bear.

### **6.3.4 Application to Window Manufacturing**

The U.S. window industry is an ideal candidate for flexible manufacturing system technology. There is a wide range of production technologies employed in the industry. At the one extreme, there are custom window producers (such as Marvin), who will make any style window on demand using mostly manual production methods.\*\*\* At the other extreme, there are mass producers, such as Andersen, who produce a limited range of models and utilize mass production technologies. In a recent published report, it was

---

\*\*\* As described in Chapter Seven, Marvin Windows utilizes a wide range of production technologies, including some very sophisticated, fully-automated machines. However, highly customized, one-of-a-kind windows are fabricated manually.

estimated that the labor productivity of Andersen Windows was 2.5 times the labor productivity of Marvin Windows, but that further increases would be difficult.<sup>12</sup> Clearly, this shows that there is a segment of the window market where variety and flexibility are critical. Likewise, there is a segment of the market that is price sensitive and is satisfied with standard sizes and types of windows.

Flexible manufacturing system technology could benefit producers in both market segments. The custom window producers could vastly improve the productivity of their flexible operations by automating information flows and/or production tasks. Costs would be reduced, quality would increase, and faster production rates would decrease the production time and thus the turnaround time required to produce a custom window. Custom producers would be more responsive and increasingly cost competitive with the mass producers, and could potentially attract some of the demand from the mass producers.

The mass producers could adopt the technology also. They would be able to increase the variety of products that are produced and they could more easily introduce new styles to replace those that were not selling well. In addition, they could minimize work-in-process and finished goods inventory. Thus, they would increase their capital productivity, at a time when labor productivity may have peaked.

### **6.3.5 Defining Components: Use of Subassemblies**

Homebuilding consists of a sequence of assembly processes that utilize a kit of parts. As described in earlier Chapters, numerous components are pre-assembled off-site, including: modular houses, mobile homes, roof trusses, kitchen and bathroom cabinets and vanities, mechanical systems, appliances, pre-hung doors, windows, and others. In fact, a shifting of value-added from on-site to off-site operations is occurring. The nature of this shift has brought about an increase in the use of subassemblies. This phenomenon is readily observable. In fact, some portions of the house are exclusively prefabricated. However, certain components of the house (such as wall panels and cabinets) are both prefabricated and site-assembled. There is a question as to what should be assembled on-site and what should be assembled off-site. In other words, to what extent should subassemblies be utilized in off-site production?

Amblard attempted to answer this question and hypothesized that there could be an inherent advantage of the use of subassemblies in production systems — that the output rates of a production system that utilized subassemblies would be higher than a system that did not use them due to a superior ability to attenuate variability in processing times

---

<sup>12</sup> Piatak, John R., "An Analysis of the United States Window Industry," Massachusetts Institute of Technology Department of Civil Engineering, S.M. Thesis, 1991.

for steps in the assembly process.<sup>13</sup> He defined two contrasting types of production systems. An arborescent system is defined as one with the maximum possible use of subassemblies. A product that is assembled in this way would have a tree-like, multi-branched parts tree representation, thus the name *arborescent*. The second type of production system is a sequential system, in which no subassemblies are used. Each piece is installed individually in the product.

Amblard's analysis assumed the production of a single-product. By definition, a single-product manufacturing environment produces identical products. In multi-product manufacturing environments, there are other advantages. Multi-product manufacturing environments produce a variety of products or one product in several varieties. Amblard conducted a literature search of the qualitative advantages and disadvantages of the use of subassemblies for single-product and multi-product manufacturing environments.

Amblard found that in multi-product manufacturing environments, subassemblies provide advantages related to modularity and commonality. For example, if the same module can be used in many different products, the design costs can be amortized over each product. The component can also be produced in larger volumes, possibly with more efficient mechanized or automated equipment. Since fewer types of parts need be inventoried, lower inventory and overhead costs will be incurred. In addition, repair is facilitated since fewer standard replacement parts are needed. However, the use of subassemblies can also be a disadvantage in some cases, if superfluous parts are required to stabilize or otherwise complete the subassembly.

In the case of a single-product manufacturing environment, the advantages of subassemblies are less clear, when modularity and commonality are not relevant. Amblard suggests that while there are reasons for the use of subassemblies in a single-product manufacturing environment, the reasons may not result in advantages. Such reasons include simplification of the problem, the ease of overall system optimization, the ease of assembly, and enhanced product quality through facilitated testing and inspection. However, reasons against subassembly use include the existence of no natural or only awkward subassemblies, subassemblies may be prone to damage, subassemblies may be difficult to transfer, higher overhead may result if subassemblies are produced in separate production facilities, and the overall production system may be less integrated.

However, the key point of the research was to determine which process structure was better able to attenuate variability in processing times for assembly steps. Clearly, for deterministic processing times, the output rate is the same in each system and is governed by the processing time of the slowest step. For stochastic processing times, Amblard found that both systems performed almost identically. Depending on the locations of the

---

<sup>13</sup> Amblard, Guillaume Pierre, "Rationale for the Use of Subassemblies in Production Systems: A Comparative Look at Sequential and Arborescent Systems," MIT S.M. Thesis in Operations Research, May, 1989.

variability, each system was preferable in some instances, but the differences between the systems were negligible. The conclusion was that there is no inherent advantage in the use of subassemblies in terms of increased output rate for systems with stochastic processing times (which real world systems have).

Therefore, subassemblies are most advantageous when different production processes can be used to produce the components, and when modularity or commonality can be exploited. In the case of multi-product manufacturing environments, the use of more highly automated processes may be enabled due to the increased production volume of each subassembly.

Subassemblies are currently used in homebuilding in cases where homebuilding utilizes a multi-product manufacturing process. In other words, modularity and commonality are exploited to mass-produce subassemblies (using more efficient mass production processes). The important point is that *sub-components are beneficial when advantageous processes can be employed.*

Today, computer integrated manufacturing systems and flexible manufacturing technologies can be applied to processes that require greater product variety and lower production volumes than mass production systems could provide. As these technologies proliferate, the subassemblies they produce will tend to be more competitive than the individual components assembled by other means. Thus, subassembly use should increase with increasing use of flexible manufacturing systems.

When defining subassemblies to be produced with new technologies, there are numerous economic factors to consider. These include:

- the cost of manufacture and assembly on-site;
- the cost of manufacture and assembly off-site;
- the incremental shipping cost — the cost to ship the assembly to the site less the cost to ship the materials to the site;
- the value of the time savings;
- the cost of quality — off-site production should improve quality;
- the value of flexibility and variety;
- the value of increased product performance;
- the value of future process improvements — the option value associated with being in a better position (off-site) to improve operations as production technologies improve;
- ancillary benefits to other tasks from producing (high quality) components and assemblies off-site.

Such an analysis is beyond the scope of this Thesis. It is up to individual firms to analyze the benefits and costs of implementing flexible manufacturing system technologies, and to plan their production accordingly.

## 6.4 Technological and Non-Technical Hurdles

There are significant technological and non-technical that must be overcome for flexible manufacturing systems and computer integrated production technologies to be widely used in the housing industry. These are discussed below. In this Section, hardware refers to material processing equipment and software refers to information processing systems.

### 6.4.1 Hardware Costs and Capabilities

Accuracy, flexibility, speed, and scale are important considerations for the design of an automated system. To date, large automated systems have not been developed, partly due to the inability of large manipulators to be accurate, fast, and affordable. Therefore, the development of a system large enough for the assembly of an entire house is unlikely in the near future. However, it is possible that fully-automated flexible assembly systems can be developed for pre-assembled components and considering the tolerances required in construction, possibly even for three dimensional modules.

An additional problem is that traditional equipment for handling materials and feeding parts (vibratory, reciprocating, rotary, and centrifugal feeders) are not well suited to large construction materials such as framing members. New equipment and new ways of handling and feeding parts must be developed.

A study by Boothroyd concluded that state-of-the-art automated assembly is not economical for production volumes less than one hundred thousand units per year.<sup>14</sup> If that is correct, then either technology must improve or ways to use existing technology more efficiently must be developed. It should be noted, however, that this study was focused on the automotive industry, and may not be directly applicable to the housing market. In addition, the study was done in 1984 (the age of the first IBM PCs). Since then, giant leaps have been taken in computers and electronics.

Each of the technological hurdles listed above, and others that are not listed, are really economic hurdles. The development of most automated systems for off-site operations is within the capability of engineers and designers with today's technology. However, the operating cost effectiveness of the systems and the system development costs are in question. Boothroyd's study was based on the assembly of manufactured products. For assembly of housing and housing components, the volume representing the threshold of economic feasibility may be one thousand units or one million units, depending on the task.

One way to reduce the cost of automated assembly is through "design for automation." Design for automation refers to the modification and redesign of the product to simplify

---

<sup>14</sup> Boothroyd, Geoffrey G., *Assembly Automation and Product Design*, New York, NY, M. Dekker, 1992.

assembly. For off-site production, design for assembly can incorporate principles of design for manufacture and principles of constructibility to overcome some of the technical hurdles facing the design of automated off-site assembly systems.

Some typical design rules from design for assembly theory are:

- minimize the number of parts;
- analyze the remaining parts for ease of assembly;
- assemble from one direction;
- chamfer or taper parts that must fit together;
- avoid slow fastening operations such as screwing and soldering;
- design parts to be either symmetric or extremely asymmetric for easy orientation and feeding;
- avoid parts with holes or projections that could cause entanglements during feeding;
- simplify part mating to require the fewest degrees of part rotation;
- design features into parts that can be used as part locators.

In general, when redesigning a product for ease of assembly, the designer should review and consider each part as to its need, geometric relationships, ease of handling, method of assembly, and cost to assemble.

#### **6.4.2 Computer Software Issues**

The primary software related hurdle results from the disparate nature of off-site production resources. For flexible manufacturing to be achieved, data and/or information about each specific part or assembly produced must reach the manufacturing resources that will process it. As described in Chapter Five, computer aided process planning systems have been developed that allow this data to be automatically generated. However, the systems are almost always confined to machining operations or other fully automated tasks.

As described in Chapters Four and Seven, off-site production in housing utilizes manual, mechanized, and semi-automated processes in addition to some fully-automated processes. For process planning to be effective in that environment, it must be capable of generating data and information in various formats that are useful to the specific resource types. One of the goals of the case study described in Chapter Seven was to identify the types and formats of information that are required by the different production resources.

A related issue is that process planning software should be capable of seamlessly integrating with current and future production related software and computer systems used for inventory, accounting, etc. Since no standards exist for transfer or storage of the mix of data types required (three dimensional graphics, real time text data, archival data, knowledge bases, etc.), an integration strategy must be developed. Furthermore, any such system should have the flexibility to adapt to future changes in resource types.

### **6.4.3 Non-Technical Hurdles**

Non-technical hurdles include industry inertia against change, the cyclical nature of housing demand, and the fragmentation of the housing industry.

#### *6.4.3.1 Industry inertia*

The housing industry is extremely unsophisticated regarding technical matters. For this reason, it can be argued that even if the firms wanted to improve their competitive positions by the application of automation to production, most lack the ability. There may be a restructuring of the industry following the introduction of new process technology by firms. Many existing firms that are unable to compete may leave the industry. Those that can adapt will become fast followers. For off-site component producers with higher skilled work forces, such as window manufacturers, introduction and/or adoption of technologies will be easier.

#### *6.4.3.2 Cyclical nature of demand*

An argument against the development of automated systems in construction that was expressed by members of the industry during the site visits is the cyclical nature of demand faced by firms in the construction industry. Firms fear the acquisition of capital equipment and the corresponding large fixed liabilities. However, this hurdle can be overcome.

For example, some window manufacturers have invested in expensive automated equipment for some tasks. It was found that the firms were able to isolate themselves from the cyclical nature of demand by expanding into the window replacement market, thus creating an expanding and growing market overall.

Other types of component manufacturing may have similarly diversifiable market risks. For example, kitchen cabinet manufacturers could focus on the remodeling market, as the window manufacturers did. Firms can diversify if they create production systems that are flexible enough to serve many markets, or many segments of the market. For example, the same equipment used to produce precast concrete foundation panels for homes could be used to produce precast components for commercial use. This would achieve diversification between market segments. Another approach to diversification is the exploration of global markets. In fact, several modular home producers have recently been diversifying into global markets.

#### *6.4.3.3 Industry Fragmentation*

It is interesting to note that there are segments of the components industry that are far from fragmented. Suppliers of gypsum products, structural clay products, particleboard,



and softwood plywood all operate in oligopolistic markets.<sup>15</sup> Suppliers of these four components have one thing in common: they all have highly automated production processes.

The fragmentation of the building products industry may be overcome by components suppliers who utilize automated production systems. The automated capability builds entry barriers to shield potential competitors while creating economies of scale and scope and driving out existing competition. Thus, while some critics say automation will fail in construction because the market is too fragmented, it is possible that automation will succeed in construction and cause industry consolidation.

## 6.5 Conclusions

There are numerous benefits that can be achieved by increasing the use of flexible automated production technologies in the housing industry, including increased quality and flexibility, decreased production time, and improved production capabilities. In addition, better jobs are expected to result and some firms may capture a significant and potentially sustainable competitive advantage.

These benefits are not likely to be achieved by automating on-site processes. A better approach is the implementation of flexible manufacturing technologies in off-site production. Customized components and subassemblies can be produced with high variety and installed on-site. By linking the builder and manufacturer directly, distribution chain costs, which combine to account for over eleven percent of housing construction costs, can be reduced through the direct, just-in-time delivery of the components.

This chapter presented a vision of how flexible manufacturing system technologies can be applied to off-site production in housing. They have the potential for impacting off-site production in several ways:

- 1) by increasing the flexibility and efficiency of many of the manual operations in component production through automated information processing;
- 2) by allowing customized products to substitute for mass produced products;
- 3) by allowing some manual processes to be replaced with automated processes;
- 4) by increasing the competitiveness and use of off-site produced subassemblies.

The effectiveness of impacts two and three will depend on the ingenuity of machine designers to build cost effective flexible machines, the ability of product designers to apply design for assembly techniques to subassemblies, and the ability of future researchers to make technological advancements in production equipment. However, the

---

<sup>15</sup> Slaughter, Sarah E., "Rapid Innovation and the Integration of Components: A Comparison of User and Manufacturer Innovations Through a Study of the Residential Construction Industry," Massachusetts Institute of Technology, Department of Civil Engineering, Ph.D. Dissertation, 1991.

flexibility requirement demands that for all impacts, information processing must be automated. For off-site production in housing, automated process planning techniques must be capable of integrating with diverse types of production resources.

In summary, this Chapter identified the areas of potential applicability of computer integrated production technologies in the housing industry and presented a vision for how the industry might utilize and benefit from such technologies. The next Chapter provides a detailed account of production at a major window manufacturer. Chapter Eight then presents an approach to automated process planning for diverse types of production resources and demonstrates how such an approach can be applied in window manufacturing.

## 7. A Case Study in Window Manufacturing

### 7.1 Introduction

Marvin Windows is a major supplier of wood and aluminum clad windows for residential and commercial construction. The firm is one of the three largest window manufacturers in the United States,<sup>1</sup> and is the largest supplier of made to order windows. This chapter represents the findings of a case study performed at Marvin Windows in August 1994.

The purpose of the study was to explore how the concept of design-manufacturing integration can be applied in practice. The focus was on the identification of real applications that either have been or could be developed for automating the generation and flow of information from design to production. In addition, the study identifies ways that such systems do or could improve costs, quality, flexibility and/or time by increasing production efficiency, by maintaining tighter production controls, by improving scheduling, etc.

This report provides a description of Marvin's manufacturing operations at the Warroad, Minnesota plant. It is an excellent illustration of the benefits of design-manufacturing integration both because it demonstrates some specific examples of it and because it highlights some instances in which it is lacking.

The case study focused on two areas: mapping material flows in the plant and identifying and mapping the corresponding information flows from order entry to shipping. There were three sources of data and information gathered for this study during a one week on-site investigation: interviews of numerous plant personnel were conducted throughout the week; orders were tracked throughout several departments during which the material and information flows were noted; and, a consultant's report on reengineering the order entry process was reviewed. Marvin's plant manager commissioned the report earlier in the year.

### 7.2 The Product

In order to make the description of the production operations described below clear and understandable, a brief description of the product line at Marvin Windows is provided here. The base product line is segmented by type of window and by window shape. Each of the major classifications represents a different production department. These classifications include Casemaster, Casemaster Clad, Double Hung, Double Hung Clad, Double Hung Magnum, Wood Gliders, Clad Gliders, Round Tops, Bows & Bays and others.

---

<sup>1</sup>Harris, John, "The Window Frame as Fashion Item," *Forbes*, April 30, 1990.

Double hung windows are standard windows with two sash that move vertically. A Double Hung Magnum is a stronger, heavier version of a double hung window. It can accommodate larger glass sizes and a wide range of glazing options. Casemasters are casement windows. A casement window has a hinged sash and swings open, usually by turning a crank. Casemasters are often combined with other windows to form assemblies, bow windows, or bay windows, as described below. Round Top windows include all windows that have curved shapes, including circular and elliptical windows, gothic tops, etc. Bows and bays include all large assemblies for bow windows and bay windows. Typically, these windows are composed of smaller windows connected together.

### **7.2.1 Custom Windows**

Marvin Windows' philosophy is that if the customer can conceive of it, Marvin can build it. There are virtually no limits to what they can produce. One example of this product flexibility, which is described in their catalog, is a window assembly that resembled the wings of an osprey. However, art of this type is the exception, and is fabricated largely by hand.

### **7.2.2 Options**

Numerous options are available for Marvin windows. The wood interior surfaces of the window can be unfinished or finished with a prime coat of paint. The exterior surfaces can be unfinished, finished with a prime coat, finished with Marvin's XL coating (a high quality coating material that is not available for on-site application), or clad with extruded aluminum.

Glass is available in single, double, or triple glazing. It can be coated with Northern Low-E or Southern Low-E energy saving coating. Southern Low-E glass can also be bronze tinted or gray tinted. Inter-glass spaces can be filled with argon or krypton gas. Single glazed windows can also be equipped with optional removable glass energy panels on the interior of the window.

Window muntins (the wood or plastic "grills" on windows) are available in three styles. Authentic Divided Lites (ADL's) have real muntin bars (with the glass cut into individual pieces). Simulated Divided Lite (SDL) muntins are permanently bonded to the glass. The advantage of SDL's is that the glass is not thermally broken. The third option is removable grills, which make for easy cleaning. Custom shaped muntins are also available.

The PowerDrive motorized sash option offers an alternative to hand cranking. It allows a window sash to automatically be opened and closed. It can be controlled by a wall switch, a remote control, or a rain sensor. PowerDrive is available for casements, awnings, and roof windows.

Other options include jamb extensions, extended sill horns, brick mould casing, muller units, nailing fins, custom colors, acrylic glazing, laminated glass, and various hardware options and colors.

The combination of different window styles, numerous options, and unlimited sizes and shapes results in a very high degree of product variety and necessitates a high degree of flexibility in production. However, all windows are assembled from a well-defined kit of parts. Even though the sizes and shapes may be unique, each window has identifiable parts: frames, sash, grills, glass, spacers, jambs, weather-stripping, hardware, screens, etc. In turn, these parts are often subassemblies of smaller but also identifiable parts. Consequently, it is possible to develop a hierarchy of constituent parts that encompass all possible windows. In terms of object technology, we can define a class composition hierarchy that depicts this breakdown of constituent parts. In addition, we can define a class hierarchy, which depicts the similarities and variations of parts that comprise the kit of parts. The significance of these hierarchies is explained in Chapter Eight.

### **7.3 Production Control**

#### **7.3.1 Organization**

Compared to other firms in the millwork industry, Marvin Windows is a very large manufacturer and has experienced rapid growth. Approximately three thousand employees currently work at the Warroad location, up from about nine hundred employees seventeen years ago. The factory occupies two million square feet of space. In contrast, Auerbach reported that for the overall millwork industry in 1987, seventy-two percent of establishments had twenty or fewer employees, and less than five percent had one hundred or more employees.<sup>2</sup> According to another source,<sup>3</sup> the average number of production workers in a millwork firm in 1989 was twenty-eight, equaling roughly sixty-four percent of the average number of workers in all U.S. manufacturing firms. Millwork production workers tend to be skilled and in 1989 received wages equal to ninety-seven percent of the average for all U.S. manufacturing industries.

Marvin Windows' manufacturing group is organized into departments by product type. The best way to describe production operations in these departments is to describe the material and information flows that occur in the course of the process. First, a conceptual view of the overall process is presented, followed by a description of the information flows associated with production planning and control. In the next section, the material flows and information required for material processing are described in detail at the departmental level. Not all departments were studied, but the process flows through representative departments illustrate production operations.

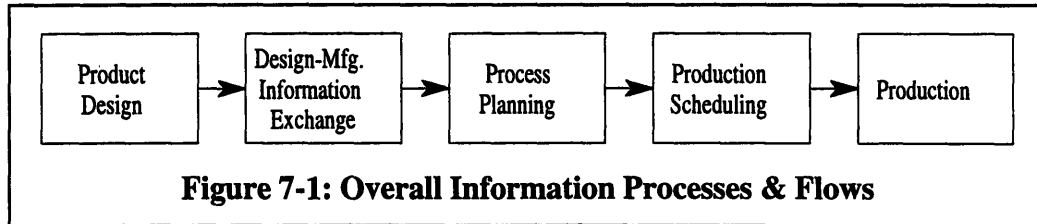
---

<sup>2</sup>Auerbach, Mitchel I., "Millwork Industry: Profile and Trends," *Construction Review*, September/October, 1989.

<sup>3</sup>Darnay, Arsen J. Editor., *Manufacturing USA: Industry Analyses, Statistics, and Leading Companies*, Volume 1, SIC 2011-3299. 1993.

### 7.3.2 Overall Process

At Marvin Windows, the information flows and the steps required to process that information are similar to those of other types of manufacturers. The overall process is characterized here, and each step is described in more detail below.



As shown in Figure 7-1, the original source of information for the entire process is the window design. In Marvin's case, architects or builders can design or specify a window with the help of the Marvin Design System (MDS) and/or the product catalog. Information must then be transferred to the manufacturing function. Marvin accomplishes this through the order entry process. Two types of process planning then occur. First, for non-standard sizes and shapes, a list of the sizes and shapes of all of the required parts must be created, since this information is required for production. Second, production orders for each of the departments involved in manufacturing the window must be created from the completed window order. Production scheduling then takes place. Marvin's scheduling process consists of assigning a window to a shipment (truck number) and sequencing production according to the shipping schedule. Finally, information from the design, process planning, and scheduling steps flows to the production floor and the window is actually manufactured and shipped.

These five basic steps are common to virtually all manufacturing environments. However, the technologies and management strategies which a firm utilizes in the implementation of each step will ultimately determine the effectiveness of the operation in terms of cost, quality, flexibility, and time. Typically, the effectiveness of the operation (in terms of cost, quality, and time) increases as the degree of design-manufacturing integration increases. The focus should be on providing that integration without sacrificing flexibility.

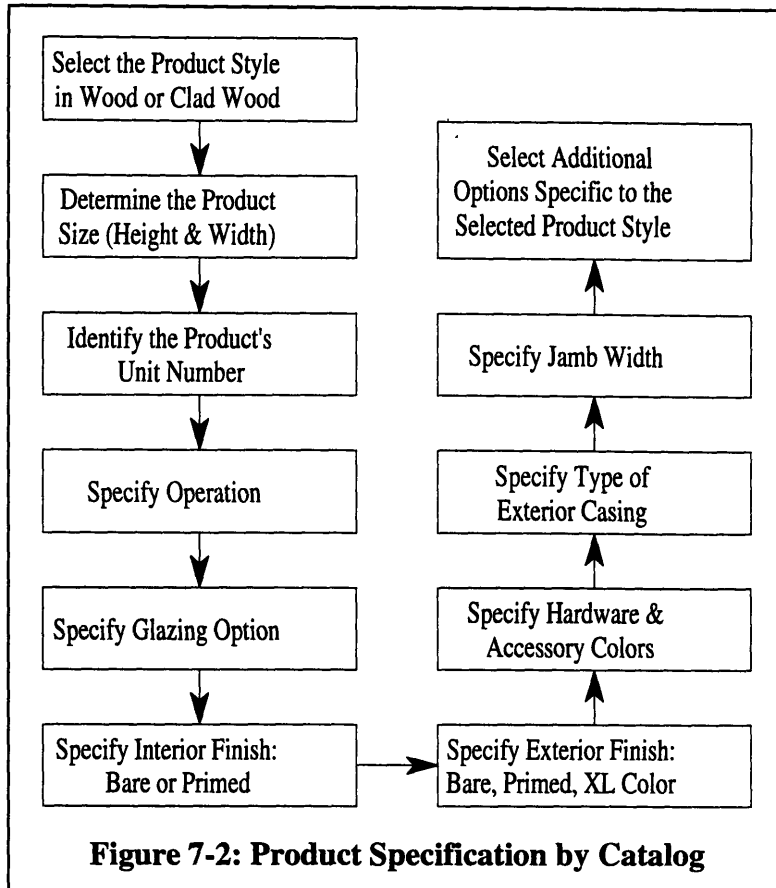
### 7.3.3 Window Design and Specification

Marvin supports the design process in two ways, through a printed catalog and through a set of computer programs known as the Marvin Design System, or MDS.

The Marvin catalog is the primary source of information for choosing or specifying windows. As shown in Figure 7-2, ordering a window from the catalog is an eleven step process. Each step further narrows the range of possible varieties. By the last step, the designer has uniquely defined the window.

In step one, the designer chooses the desired window type and specifies whether or not it is to be clad with aluminum. Next, the designer determines the window height and width based on either the masonry opening, the rough opening, or the frame size. The product's

unit number, a code that describes the window, is then identified. For example, a WDH4012 window is a Wood Double Hung window with glass that is forty inches wide and twelve inches high. The glass size is not always as easily identifiable from the code. For example, a CCM2072 5W is a Clad Casemaster assembly composed of five Casemaster units mullled together, each of which have glass that is 19.5625 inches wide and 65.875 inches high. The next step is to determine and specify the operation of the window. For a double hung window, both sash can be operational, both sash can be fixed, or one sash can be operational with the other one fixed.



The designer then chooses the glazing option, which differs for each type of window. For example, Clad Casemaster units are available with double glazed Northern or Southern Low E glass and with or without Argon gas. The glass can be bronze or gray tinted, can be tempered, and can have two sizes of Simulated Divided Lites. Wood Double Hung windows can be double or single glazed, and single glazed are available with or without a removable energy panel. The glass can be bronze or gray tinted, tempered, Northern or Southern Low E coated (with or without Argon gas), and can have several varieties of Simulated or Authentic Divided Lite muntins.

Next, the designer chooses the interior and exterior finishes. Two interior finish options are available: bare wood or primed. There are three exterior finishes available for wood (unclad) windows: bare wood, primed, and finished with the XL coating. For clad and finished wood exteriors, the designer must specify the color of the cladding or finish. Next, the types and colors of hardware and accessories must be specified. Again, these choices vary slightly depending on the type of window. The designer next specifies the type of exterior casing and jamb width. Finally, any other options that are specific to the particular window type must be chosen.

Clearly, the complete specification of a window is a complicated process, even when the window is being specified from a catalog of “standard” windows with a variety of sizes

and options. There is a great deal of information required above and beyond the opening size. The process is further complicated by the fact that Marvin also produces non-standard, completely customized windows. In addition to the data mentioned above, design sketches or other information may be required.

The Marvin Design System (MDS) is Marvin's other means of supporting the design process. The MDS software comes in three versions. One version is an add-in program that runs within AutoCAD Release 12 for DOS. One version runs in AutoCAD Release 12 for Windows. The third version is a stand-alone program that runs under Microsoft Windows. The MDS computerizes the specification process described above and allows complex special windows to be designed.

Custom-sized windows can be designed simply by changing the sizes of otherwise standard windows during the specification process. Custom-shaped windows can be designed in the AutoCAD versions of the software through a rules-based drawing interpreter that can convert a single line AutoCAD drawing into a custom Marvin window.

Specified windows can be placed in an AutoCAD drawing in one of three formats: 2-D plan, 2-D elevation, and 3-D. The 3-D representations, including the muntin grills, are modeled with 3-D polyface meshes, so they are ready for rendering.<sup>4</sup> The program also includes an AutoLISP tool that breaks a double line wall and inserts a plan view of a window into it. In addition, the system can output a report listing all the windows and doors for a project, along with their corresponding product codes.

The MDS has been considered a successful project. Many copies have been distributed and the software has reportedly been well received. It has even won an award as one of the most innovative custom business solutions that run in Microsoft Windows at the "Windows World" trade show.<sup>5</sup> However, the MDS seems destined to remain an isolated electronic catalog and design system. There apparently is no long term strategy for integrating the package with any other programs used by Marvin. It reportedly will *not* be linked to the Marvin Quote System, which is described below. The potential for integration of the MDS with other systems and the benefits that could result from such integration is presented later in the chapter.

### ***7.3.3.1 Order Entry***

Marvin's Order Entry department represents the vital link between design and manufacturing. As shown in Figure 7-3, there are currently two ways that Marvin receives orders: by phone and through the direct order entry (DOE) system. The DOE system is a

---

<sup>4</sup>"Marvin Design System," *CADalyst*, October, 1994, pp. 33-34

<sup>5</sup>*Microsoft Magazine*, Fall, 1994, pg. 7.

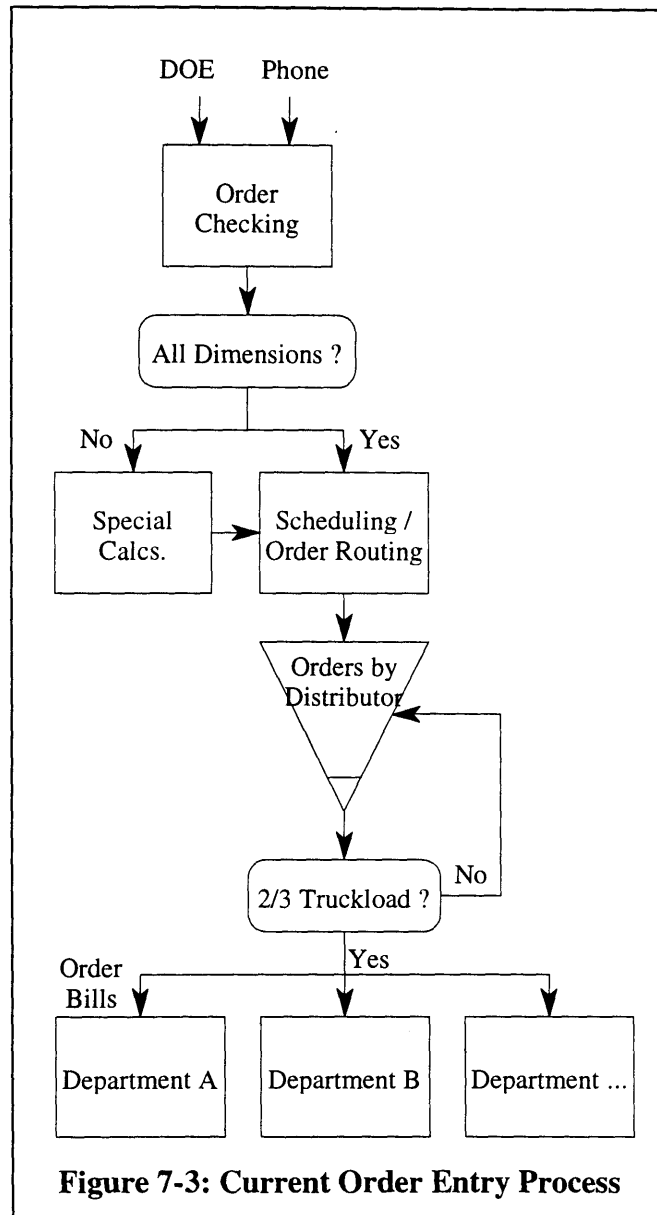


way for dealers and distributors to transmit orders electronically. In each case, an order checking process then occurs.

When workers receive phone orders, they write the orders manually and note any special information that is required. Next, workers translate these customer orders into work orders and enter them into a computer. Order checking personnel print the orders and compare them to the phone notes, checking for errors.

When workers receive orders through the direct order entry system, they print the orders. Order checking personnel must then verify all the information since the DOE system has no built-in error checking. If there is an error, the customer service representative must contact the customer for a clarification of the information.

The manual link between design and manufacturing and the feedback loops for error correction are somewhat slow and inefficient. Orders should be electronically transferred and automatically translated into work orders (or some other useful form) so that retyping is unnecessary. In addition, it would be better if order checking occurred at the time of order creation. If customers were unable to enter or transmit incorrect orders, then order checking at Marvin would be unnecessary. Better integration of this process would clearly increase efficiency and quality, and decrease order entry time.



**Figure 7-3: Current Order Entry Process**

Marvin's approach to the integration of this process is embodied in the Marvin Quote System (MQS). The MQS is a system that is being developed for creating and entering orders (see Figure 7-5). It was scheduled to replace the direct order entry (DOE) system in January 1995. The MQS has rules-based data validation for sizes, finishes, styles, and options. Therefore, designers will only create complete and correct orders, and order checking at Marvin will be unnecessary. The system will output a "part number," which is a long code that uniquely identifies the particular design. Order information can then be transferred electronically. However, the strategy for automatically translating orders into

Marvin work orders or some other useable form is unclear. In August 1994 there were eight hundred beta copies of the MQS system being used by distributors and dealers. Once the final version is released and they begin to receive error free orders, Marvin can take the next step (translation to Marvin work orders and/or other downstream linkages).

### **7.3.3.2 *Special Calculations***

Orders for standard sized windows are informationally complete. However, key dimensions of custom sized and/or custom shaped windows must currently be calculated. The Special Calculations group is responsible for this task. In particular, the Special Calcs department is responsible for determining the sizes of the components and parts needed to manufacture the window. This function is a critical part of the process planning function.

Two types of orders enter Special Calcs: those that can be calculated by computer and those that must be calculated manually. Special Calcs operators currently use between one hundred and one hundred fifty programs stored on the VAX network. Each program computes the required dimensions for a specific window type or shape. For example, each Roundtop shape has been assigned a unique shape number. A separate program exists for each shape number. Likewise, a new product requires the development of a new program.

It takes about two months to develop a new program. Programs are written in Basic and average one to two thousand lines of code each. The user interfaces are character based, somewhat cryptic, and require knowledgeable operators.

Currently, fifteen people work at Special Calcs stations full time. They are able to process about ninety percent of the orders entering the department. However, they must manually (or sometimes partially manually) compute the other ten percent of orders that fit no computer program. Computing these orders manually reportedly takes as long as computing the other ninety percent with the help of the computer programs.

The manual calculations are time consuming and requiring a very high level of expertise. This ten percent of orders is composed of round tops, special polygons, special bows and bays, or otherwise odd lites.

Special Calcs performs a key task at Marvin. The method used, however, is not error proof. Errors sometimes occur when workers reenter the data into the programs. The manual computations as well carry the risk of human error. On the other hand, the shop floor seemed satisfied with the quality of the calculations. Only one person cited Special Calcs errors as a problem. That person worked in the Double Hung Magnum department, which relies most heavily on Special Calcs, since all orders are specials.

Figure 7-4 shows a sample Special Calcs output for a Clad Casement window. Special Calcs operators print the computed dimensions on dot matrix printers. They then literally cut the printed dimensions out of the page and staple them to the order sheets. The output consists of dimensions for all components of the window. In that sense, it represents a bill of materials. However, they do not call it a bill of materials. They feel that a bill of

materials should provide a list of the constituent parts that will be used to build the window (standard sizes that will be cut to size). Since the list of sizes of stocked parts is well defined, this information would be easy to add to the system. The system would just have to do a table lookup for each dimension.

A portion of the output is also electronically linked to a downstream manufacturing operation. For special sized rectangular glass, the system currently creates a file of glass dimensions which is downloaded to the DeMichaels machines, which cut rectangular glass shapes. This operation is described below. The system could potentially download information directly to the metal and wood cutting areas also, but this is not currently done. The benefits of such integration will be described below.

```

** QUOTE **
* 1W CCM OPERATOR
  RO 20 x 60
  Glazed INS CLEAR
  1-LITE

** QUOTE **CMC SASH
FRAME OSM 19 x 59 1/2
--3/4" 1-LITE G.S. 14 9/16 x 54 1/4
1-LITE D.O. 13 1/2 x 53 3/16
HEADER 19
SILL 19
JAMBS 58 1/2
OPER. HEADER STOP 14 15/16
OPER. SILL COVER 14 15/16
OPER. JAMB STOP 57 1/8-1/64
FRAME WEATHERSTRIP
  HDR & SILL DIM. A 17.095
  JAMBS DIM. A 57.585

GLAZING CAP
  RAILS OVERALL 15.031
  STILES OVERALL 53.660
GLAZING BEAD
  RAILS OVERALL 15
  STILES OVERALL 53 3/16-1/64

** QUOTE **CMC PARTS
HEADER 19
SILL 19
JAMBS 58 1/2
RAILS BTWN TENONS 15 5/32
STILES BTWN SLOTS 54 7/16

** QUOTE ** METAL
-- WHITE FRAME METAL --
HEADER METAL 18.978
SILL METAL 18.978
JAMB METAL 59.478
-- WHITE SASH METAL --
RAIL METAL 17.375
STILE METAL 57.813
GLAZING CAP
  RAILS OVERALL 15.031
  STILES OVERALL 53.660

** QUOTE **GLASS
3/4" 1-LITE G.S. 14 9/16 x 54 1/4

** QUOTE **WS
** CCM ALUMINUM SCREEN - BRONZE SURROUND (NEW)
SCREEN OSM 15 3/8 x 55 13/32
HORIZ. FRAME 15 1/16
VERT. FRAME 55 3/32
DIM. A 10 9/16-1/64
DIM. B 46 11/16-1/64

```

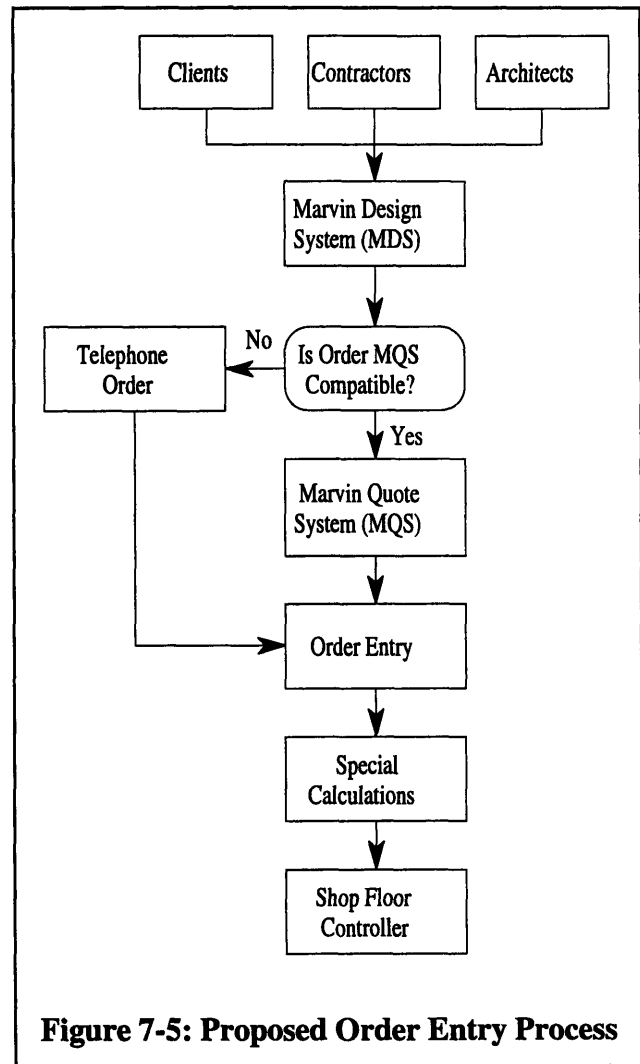
Figure 7-4: Special Calcs Sample Output

### 7.3.3.3 Improved Order Entry Process

As shown in Figure 7-5, the order entry process is in the midst of change. Under the envisioned system, clients, contractors, and architects will be able to design and specify windows using the MDS. If the order is MQS compatible, and not all custom windows will be, the dealer or distributor with the MQS system will generate a quotation. The dealer or distributor must phone in orders that are not MQS compatible and they must manually generate a quotation. When the factory receives the order, it will be forwarded to Order Entry, Special Calcs, and Production, as required.

There will be clear benefits due to the improved integration of this new process. Order checking can be greatly reduced and eventually eliminated. Translation and retyping of orders can also be eliminated. The next step must be to integrate the Special Calcs function with the upstream operations.

Reportedly, there are fifteen full-time, skilled people operating Special Calcs workstations. In addition, an equivalent amount of effort is reportedly spent manually computing the windows that do not fit the programs. Thus, roughly thirty full time people are required for special calculations. If the average worker costs the company 25,000 dollars per year including benefits and employer contributions, then the annual cost of the Special Calcs function would be 750,000 dollars. This amount does not include the cost of the two full time programmers who maintain the programs, the quality related costs associated with calculation errors, or the costs associated with the increase in cycle time required for Special Calcs processing.



**Figure 7-5: Proposed Order Entry Process**

Integration of Special Calcs could occur in numerous ways. The MQS and/or MDS could potentially download files directly to the network, which would eliminate data reentry. However, workers would still have to manually compute the windows that are not compatible with the Special Calcs Programs.

The Special Calcs programs could be integrated “as is” into the MQS and/or MDS. Some may resist this idea by saying that the programs must run on the workstations to be fast

enough. This may have been true ten years ago, when Special Calcs began their programming efforts. However, today's PCs are faster than the workstations of ten years ago. The programs are only a couple thousand lines of basic code, so it is probable that they would run just as fast on a modern PC. If speed did become an issue, the programs could be converted to C code. BASIC is notoriously slow because it is an interpreted language. C, a compiled language, is much faster. This approach, however, still leaves out the windows that must be computed manually.

The third approach would be to develop an improved implementation of Special Calcs programs that would encompass any and all windows. This improved implementation would then be integrated into the MQS or the MDS and would completely automate the Special Calcs function. Hundreds of thousands of dollars per year would be saved, cycle time would be reduced, and errors would be eliminated. Such a system can be implemented using an object oriented representation of window components with built in rules for relating these components. Since a well-defined kit of parts is used to assemble all windows, such a system is possible. The system would be extremely flexible, yet it would offer the efficiency of automation.

#### **7.3.4 Assembly Scheduling and Order Routing**

Once completed orders have been developed, scheduling and order routing can occur. Currently, the shipping department generates production schedules. The scheduling department simply releases orders to the necessary departments when allowed by the shipping department.

The shipping department accumulates orders by distributor. It then builds truckloads of orders for a single distributor or combines distributors to form a truckload. When an entire truck has been filled, or is at least two-thirds full, the shipping department allows the orders to be released. The scheduling department, which has been queuing the order sheets, then releases those orders that have been scheduled to the truck (see Figure 7-3). When scheduling releases orders, it distributes or routes copies to all departments that require them.

Scheduling received the copies from the order entry system, which prints multiple copies of each order, designated by department. However, errors regularly occur. Sometimes, copies are printed for departments that do not need them and sometimes, copies are not printed for departments that need copies. The scheduling department, using process planning expertise, corrects these mistakes.

There is really no reason for these errors to occur. Whatever rules have been built into the system are faulty and need to be corrected. These rules should also be integrated into the proposed design and order entry system, along with the Special Calcs programs, since all the information required to route the order is contained in the design information. In addition to detailed part descriptions, a complete routing for the window and its sub-components could be automatically generated from the design information. This would complete the automation of process planning.

### **7.3.4.1 Shipping**

The shipping department drives the entire production operation. Marvin Windows says they “don’t manufacture windows,” they “manufacture truckloads of windows.” When Shipping receives orders, they give them to one of three people (depending on which distributor the order originated from). These people must calculate the number of “openings” in each order (described below). They then sort the orders and file them by distributor and location.

An “opening” is an arbitrary measure used by Marvin that approximates the volume of a window. It was developed to provide a fast way to manually compute the shipping volume of an order. The number of openings is used to determine how many orders can fit in a truck. Marvin uses four different types of trailers. They are either forty-eight or fifty-three feet in length and have hard or soft-tops. These trailers can hold roughly two thousand openings per load.

When scheduling shipments, the scheduler considers many variables: the location for delivery (some locations never get fifty-three foot trucks), backhaul opportunities, and routing efficiency. Since all Marvin windows are made at the Warroad plant, there is a large variation in the time required to deliver the windows. Trucking times vary between two and one-half hours and forty-four hours, depending on the location. The routers try to schedule the deliveries such that they can unload everything (for multiple stops) in one day and can pick up a backhaul at the end of the same day. Backhauls consist of incoming materials. There is close to a one hundred percent backhaul rate at Marvin. Shipping dispatchers coordinate backhauls by talking to purchasing once a week and by filling in with hauls for the elevator, the Baker Plant, and the lumber yard (other nearby Marvin operations).

An integrated design and order entry system will improve shipping in several ways. First, any system that is capable of computing detailed geometric information about component parts will easily compute shipping volumes. Not only will the shipping department not have to compute the number of openings, but they will have an exact measure to use when maximizing truck loading. Second, the electronically downloaded order data could be fed into route optimization software (the consultant’s report also suggested the use of such programs). Third, once real time routing was achieved, shipping could possibly consider other means of scheduling, such as scheduling based on due dates. One potential scenario for due date scheduling is as follows: 1.) orders received would be assigned a due date based on the required processing time and the current backlog (processing times for each department would be calculated automatically based on the required process steps, which are determined from design data); 2.) production would be scheduled according to minimum float; 3.) as windows were completed, they would be sent to shipping by towline and would be bar-coded; 4.) the routing software would send the window to the correct shipping bin, based on a real time route optimization of ready-to-ship windows.

This approach would eliminate another big problem in shipping — that all the windows are not always in the bin to be loaded. When this occurs, the loaders must track down the missing orders. A study by Marvin has shown that if all of the windows are there and

ready, it takes two people six hours to load the truck. Unfortunately, since that never happens, three people are scheduled for eight hours to load a truck. In the short term, it would be extremely helpful if shipping could generate an exception report for the bin to save time and money figuring out which windows are missing. Since windows are tracked by bar-code as they enter the bins, this is possible. In the long term, the elimination of the problem would be a better strategy than developing a means to deal with it.

#### **7.3.4.2 Truck Schedule**

Currently, the truck schedule is the single document that drives production throughout the plant. The handmade schedule lists the truckloads in the shipping order. In addition, it includes an accounting of the number of each type of window that comprises each truckload. The production supervisor uses experience to determine how far down the schedule each department must go by the end of the shift. He literally draws lines on the page at these points. In addition to setting a production quota, the lines limit faster departments from going too far ahead of the others. Thus, fast departments are prevented from creating excessive work in process inventory and from being starved of supplied components. In addition, the schedule provides a view of aggregate production requirements and is used for resource (labor) allocation between departments, as the mix of orders fluctuates.

If design-manufacturing integration is achieved, then daily production schedules can be automatically generated for each department, saving additional manual effort. Orders can be scheduled either in the order released by shipping or according to a due date. The schedules can be automatically downloaded to the departments on a shift by shift basis. Physically printing and distributing the schedules is only necessary because they are manually prepared. Instead of spending time creating a schedule manually, the production supervisor can evaluate what-if scenarios for resource allocations and/or could spend more time on the shop floor supervising actual production.

#### **7.3.5 Component Production Control**

Marvin Windows does not stock finished goods, but they do stock parts. They must do this because the lead times for wood and some other purchased materials are generally longer than the lead times for the manufactured products. For example, screws have very long lead times since they are shipped from Asia. Glass lead times are nineteen days, while lumber takes a couple of months. In fact, due to the volatility of the lumber market, it is purchased as a commodity and warehoused, rather than only bought when needed. Lumber storage totals eleven million board feet.

Currently, component parts are manufactured and inventoried according to *forecasted* demand through an MRP system. This is a bit unusual. It would be expected that the input to the MRP system would be the actual demand via the order entry process, rather than forecasted demand. The reason for this is that the MRP system in use is not well suited to Marvin's type of production.

The MANMAN MRP system has been in use at Marvin Windows since 1988. It is used for inventory management, purchasing, accounts payable, and general ledger. However, no scheduling or capacity planning is performed since the program is designed for discrete parts manufacturing, while Marvin's production is customized and made to order. What this means is that the MRP system expects that every order has a bill of materials that can be entered. Further, each part on the bill of materials should represent a unique part in inventory and should have a standard part number. In Marvin's case of made to order production, part numbers are not unique, since each window could be a different size. There would need to be a different part number for every possible length of every possible part, and the number of part numbers would grow unbounded. Therefore, it is hard to enter demand information based on actual orders, so all demand entered into MANMAN is forecasted.

The forecasting is based on the expected number of truckloads and the average product mix profile for a shipment. The expected number of truckloads is based on a twelve-twelve rate of change, which is a moving total of trucks shipped, adjusted for seasonality. It is based on two measures: an index of leading indicators published by Connors Economics and firm market share measured in openings per housing start. Forecasting is done weekly.

Although this sophisticated forecasting method has been developed, more accurate requirements planning (thus lower work in process inventories and fewer stockouts) would be possible if the design and order entry system was linked to the scheduling/MRP system. One idea at Marvin is to use a front end configurator. The configurator is a rules-based system that will integrate the order entry system and the MRP system. Most likely, a new MRP system with a built-in configurator will be chosen. It is unclear whether or not the configurator would accept data from the MQS, and not require re-keying of data, but of course that would be the best approach. The optimal approach is to automatically generate the list of materials upstream and electronically transfer this information to a production control system that is designed for made to order production (MANMAN is not).

In summary, window production schedules are created manually for each shift and distributed throughout the plant. The schedules are based on truck shipments, which are compiled manually based on an approximate measure of the shipping volume of the orders received, as well as other considerations. Component production is based on forecasted demand due to a fundamental incompatibility between the MRP system and the type of production at Marvin. The details of shop level process control are described for representative departments in the next section.



## **7.4 Production Operations**

### **7.4.1 Clad Casement Production**

The Casemaster and Clad Casemaster window departments have recently been reorganized to embody the cellular manufacturing paradigm, although actual production changes seemed to be minor. The Clad Casemaster department was toured.

Part of the reorganization of the two Casemaster departments was the integration into the department of the order processing and Special Calcs functions (for Casemaster orders). This was achieved by separating the processes from other orders and transferring control over those tasks. Thus, as shown in Figure 7-6, pre-production processes differ slightly for these two departments.

#### **7.4.1.1 Clad Casement Pre-Production Information Processing**

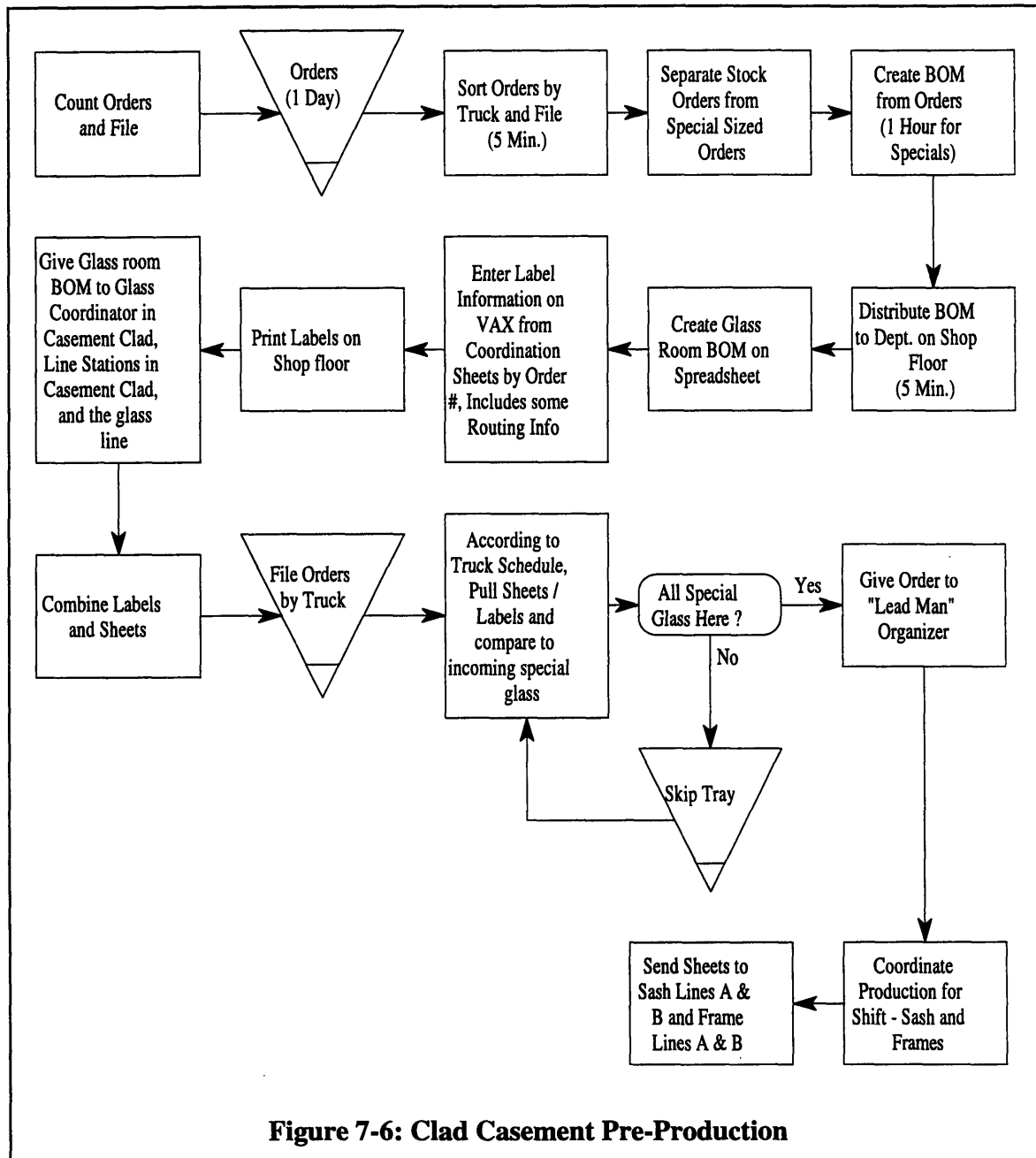
When orders are received, they are counted to get an idea of the upcoming production requirements, and they are filed by distributor. They stay filed in queue for roughly one day. The orders are then sorted by truckload according to the truck shipping schedule. Stock orders and special sized orders are separated and order processors create separate coordination sheets for each type. The coordination sheets, which list the orders according to the truck shipping schedule, are prepared on a spreadsheet by Clad Casement scheduling personnel, who reenter the information from the original order sheets.

For all Casemaster orders, one version of the coordination sheet is prepared for the glass room and a different version goes to the shop floor of the department. The coordination sheet for the glass room includes several pieces of information: the truck number, the order number, the order sheet line number (order sheets are numbered by line), the window size, the quantity, and several other miscellaneous codes and special notes. In addition to that data, the coordination sheet for the shop floor contains information needed for mulling and information regarding window operation and colors. The shop floor receives numerous copies of the coordination sheet. On the sash line, the wood and metal parts pullers, the glass puller, and the clad installer all receive copies. On the frame line, the wood and metal parts pullers, the frame assembler, and the muller all receive copies. Each sheet has all the orders for a specific truck shipment.

Order processors then reenter the data again from the coordination sheets into the VAX computer for label creation and printing. Labels are printed on the shop floor, and are combined with the coordination sheets when they are delivered to the department. At the first step in production, a label is adhered to the part and becomes the primary means for defining the part in terms of information needed for production.

Thus, shop floor workers have two sources of information: the coordination sheets and the frame and sash labels. The sash label contains the following information: the truck number, the order number, the type of window, the quantity, the size, the operation, the choice of hardware, the interior and exterior finishes, the glazing choice, and a bar-code. The frame label contains the following information: the truck number, the order number,

the line number, the bin number, the jamb size, the sash operation, the window type and size, the quantity, the ship-to address, the customer name and number, the job name, the glazing type, the hardware choice, interior and exterior finishes, a casing field, a sill field, a cuts field, a miscellaneous field, and a bar-code. The labels provide the worker with a good idea of how to build the part, while the coordination sheets augment the label information and control production order.



**Figure 7-6: Clad Casement Pre-Production**

The combined coordination sheets and labels are filed by truck shipment on the shop floor. As in all departments, production proceeds according to the truck schedule. Orders are pulled from the file according to the truck schedule. For non-standard sizes, incoming

special glass is checked and matched to orders. If the special glass has not arrived, the orders are filed in the “skip tray,” until it arrives. When glass and orders are matched, the order passes to the “lead man,” who distributes the sheets to the line and coordinates production of the sash and frames.

Pre-production information flow can be summarized as follows: 1.) a work order is received; 2.) Special Calcs reenters and augments order data; 3.) order data is reentered into coordination spreadsheets from order sheets; 4.) order data is reentered from the coordination sheets into the VAX for labels; 5.) labels are printed and combined with coordination sheets.

#### **7.4.1.2 Pre-Production Information Processing - Suggestions for Improvement**

As mentioned above, part of the “reorganization” of the two Casemaster departments was the integration of the order processing and Special Calcs functions (for Casemaster orders) into the department by separating the processes and transferring control over those tasks. The belief was that under cellular manufacturing, the department should handle all functions for the product type. This seems to be an imprecise application of the technique.

Chryssolouris<sup>6</sup> defines cellular manufacturing as production in which “equipment or machinery is grouped according to the process combinations that occur in families of parts.” Part routings can be different for different members of the family, but by following some routing, all parts can be made within the cell. One benefit of the cellular approach is reduced throughput time relative to a job shop. Since parts have limited distances to travel, routing time is decreased. In addition, large batch sizes are usually avoided. Since each part family may contain numerous varieties, each typically is made sequentially in small batches. Under these conditions, the cell can be viewed in isolation for detailed scheduling purposes. Thus, under cellular manufacturing, overall Clad Casement scheduling should be done by truck scheduling, and detailed scheduling would be via the coordination sheets. Also, windows would be completely fabricated and finished within the cell. Essentially, a factory within a factory is created.

Reportedly, little or no change was made to the actual production flow on the shop floor. Changes for the cellular approach were confined to the pre-production information processing, and these steps lack integration. Thus, few of the benefits of cellular manufacturing have been realized. On the other hand, one could argue that the cellular approach is unnecessary or not useful for this type of production. Currently, production is organized as line flows in each of the two Casemaster departments. Each window is sufficiently similar that they can follow virtually the *same routing* within the departments.

---

<sup>6</sup>Chryssolouris, George, *Manufacturing Systems Theory and Practice*, Springer-Verlag, New York, 1992.

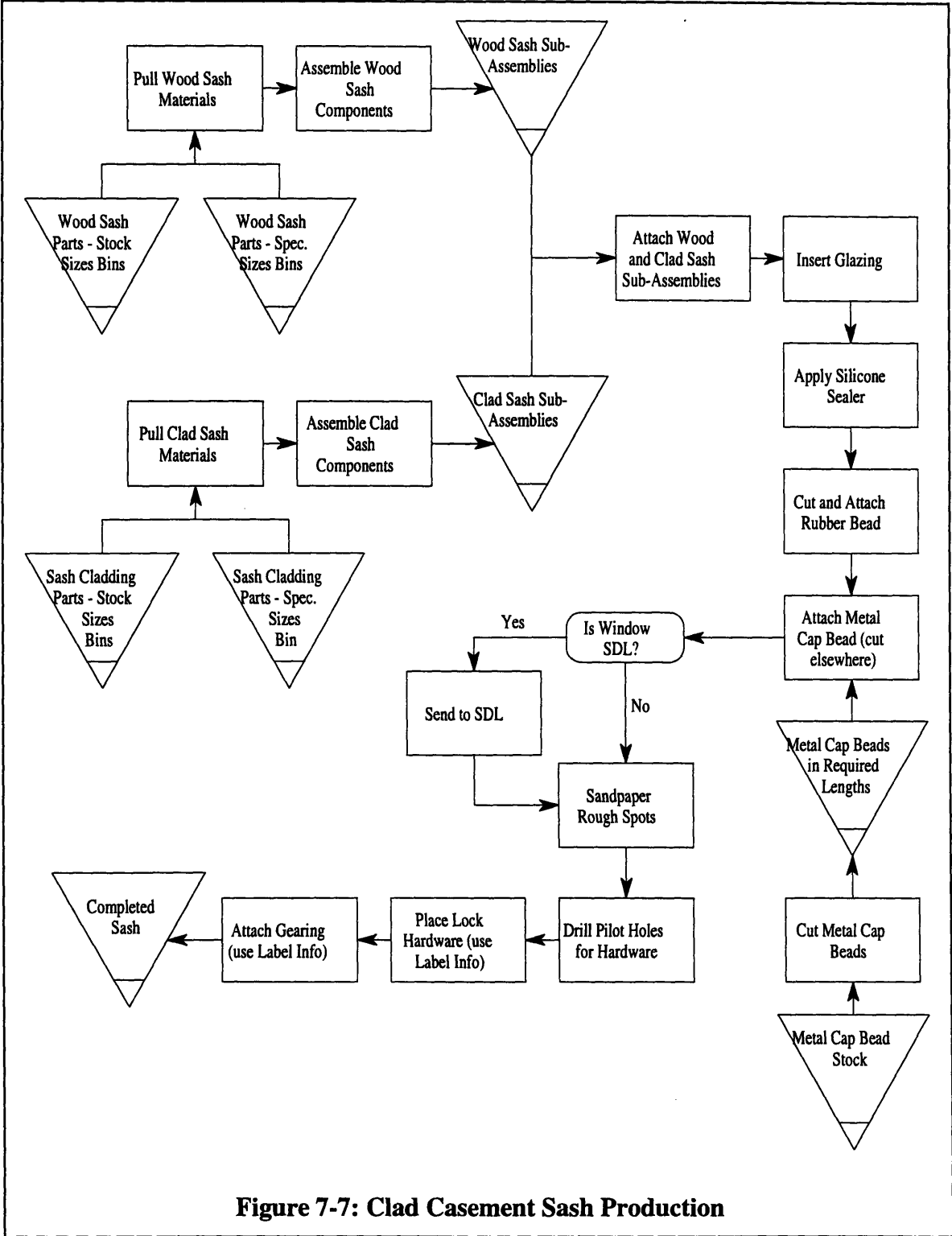
In spite of whether or not a shift to cellular manufacturing has or has not actually occurred, or whether or not such a shift is appropriate, one thing is certain. A significant amount of time, energy, and money is spent preparing orders for production due to the lack of integration. For example, the data entry for label printing (entering the label information into the VAX computer from the coordination sheets) takes three to four hours for a batch of special orders (around ninety-five windows), and about one and one-half hours for a batch of stock orders (around four hundred windows). There are about two stock batches per day and the remaining batches are specials. Pre-production information processing (which consists of process planning and information transfer) is an area where design-manufacturing integration can result in significant savings in both cost and time.

#### ***7.4.1.3 Clad Casement Sash Production***

Upon receiving orders from the lead man (with orders consisting of sash labels and coordination sheets), sash production begins. The first step is the gathering of the wood and clad parts, and the placement of the sash label on one of the wood parts. Correct part sizes are determined from the label information. Parts are stored in bins of stock sizes right at the line. For special sizes of sash, the parts have been previously precut and are queued in a separate bin. The wood parts and the clad parts are assembled separately, and the two subassemblies are attached together.

The glazing is then inserted into the sash frame and a silicone sealer is applied. For standard sizes, glass is inventoried in the department. For non-standard sizes, it comes from special glass. A rubber bead is then cut and attached, and precut metal cap beads are attached. If the window is a Simulated Divided Lite, it is routed to the SDL department so the muntins can be adhered to the glass. The sash is then checked for rough spots on the wood, and hand-sanded lightly with sandpaper as needed. The next step is hardware installation. Pilot holes are drilled, lock hardware is attached, and gearing is attached. The choice of hardware and gearing is determined from information printed on the sash labels.

The consultants' study included a time study of the Clad Casemaster sash and frame lines. The total cycle time for clad sash assembly, according to the consultant's study, is about 8¼ minutes, and 7¼ minutes for Wood Casemaster sash. All sash follow the same routing through the assembly line.



**Figure 7-7: Clad Casement Sash Production**

#### **7.4.1.4 Clad Casement Frame Production**

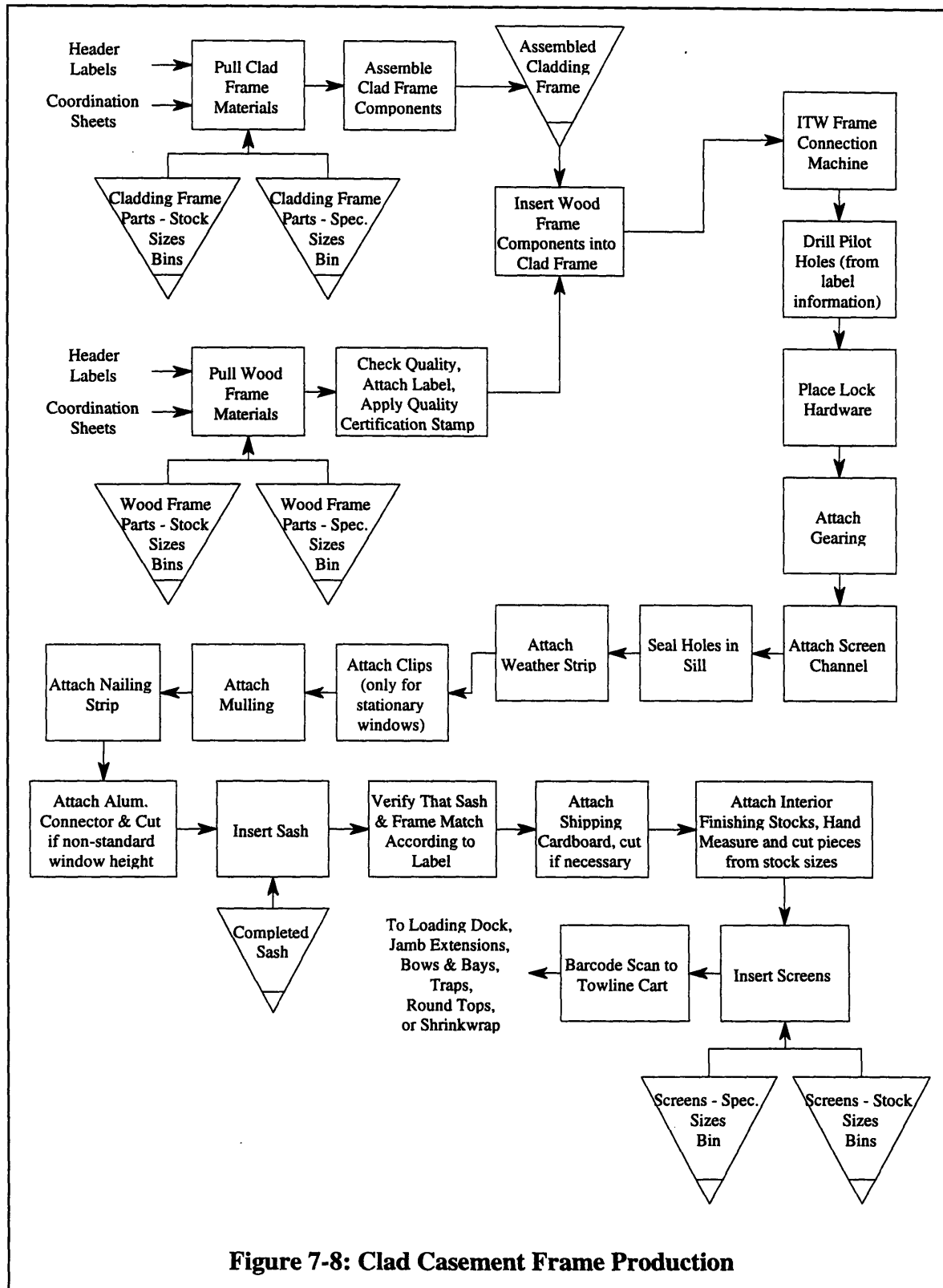
As is the case in sash production, frame production proceeds according to the printed header labels and the coordination sheets obtained from the lead man. The first step is to pull parts of the correct sizes from either the stock sizes bins or the special parts bin and attach the label to one of the wood parts. The clad parts are assembled first and the wood parts are inserted one by one into the clad subassembly. A frame connection machine then automatically fastens the frame. The flexible machine is capable of orienting and fastening a wide variety of sizes and shapes.

Pilot holes are then drilled into the frame for hardware, and locks and gearing are attached. The choice of hardware is based on information printed on the frame label. A screen channel is then inserted and holes in the sill are sealed. Weather stripping is then attached. If the window is stationary (window operation is printed on the frame label), clips are attached.

For mulled units, mulling is attached and an aluminum connector is attached and cut to length. Nailing strips are attached if required. Next, the completed sash are installed in the frame. A quality control inspector then verifies that the sash and frame match and that the window has been accurately built according to the information on the labels. Shipping cardboard is attached next, if needed. Interior finishing stocks are then hand measured, cut from stock sizes, and attached. Finally, screens are inserted, the unit is bar-coded (to track the department's production), and it is placed on a towline cart. The cart carries it to one of the following departments for further processing: Shipping (the loading dock), Jamb Extensions, XL, Bows and Bays, Traps, Round Tops, or Shrink-wrap.

According to the consultants study, the total cycle time for the Clad Casemaster frame assembly line was just under fourteen minutes. For the Wood Casemaster frame line, some of the operations differ slightly, and the cycle time was reportedly 1 1/2 minutes.

In summary, most of the information required for production on both the frame and sash assembly lines is obtained from the frame and sash labels. They are the principal means for transferring design information to the worker on the line. They also both seem to work very well. In contrast, the coordination sheets seem to be of little or no use to the line worker.



## 7.4.2 Double Hung Magnum

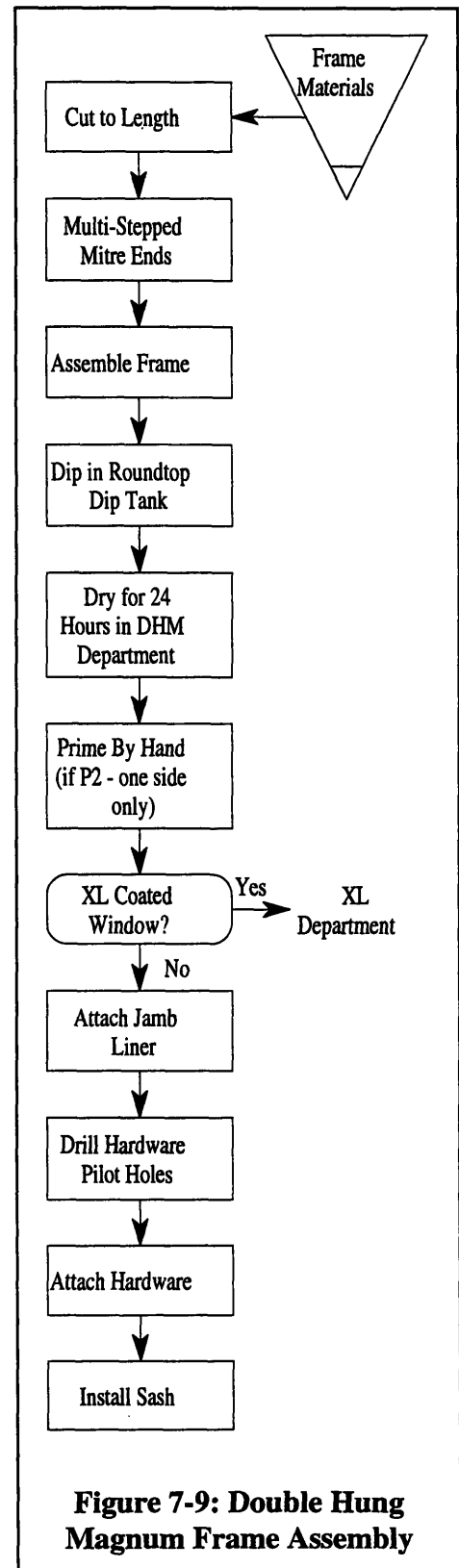
The unique nature of this department lies in the fact that there are no stock sizes. All Double Hung Magnum windows are considered specials. In order to achieve this high level of flexibility, all operations and all machines used for fabricating the window, except for dipping and XL coating, are located within the department. Ironically, Double Hung Magnum production more closely resembles cellular manufacturing than Clad Casement production.

Double Hung Magnum production proceeds according to the truck schedule, as in all departments. The department receives three copies of order sheets: one for frame assembly, one for sash assembly, and one for hardware installation. Each copy is augmented with appropriate data computed by Special Calcs.

### 7.4.2.1 Double Hung Magnum Frame Assembly

Double Hung Magnum frame assembly begins with the pulling of frame materials according to information on the order sheets. Frame parts of the correct length are cut from the material, and the ends of each piece are mitered. The frame is then assembled and connected.

The frames are sent to the Roundtop department where they are dipped in a preservative. Most parts are dipped prior to assembly as part of the preparation of parts. However, since Double Hung Magnum parts are cut on the line (as are Roundtops), they must be dipped as an assembly.<sup>7</sup> The parts are then returned to the department, where they dry for twenty-four hours. Reportedly, Marvin is considering an in-line system for dipping with fast microwave curing. This would allow windows to be dipped within the department, eliminating the risk of damaged parts resulting from excess handling.



<sup>7</sup> Reportedly, the Roundtop dip tank is used exclusively for dipping assemblies, while the North End dip tank is used exclusively for dipping parts.



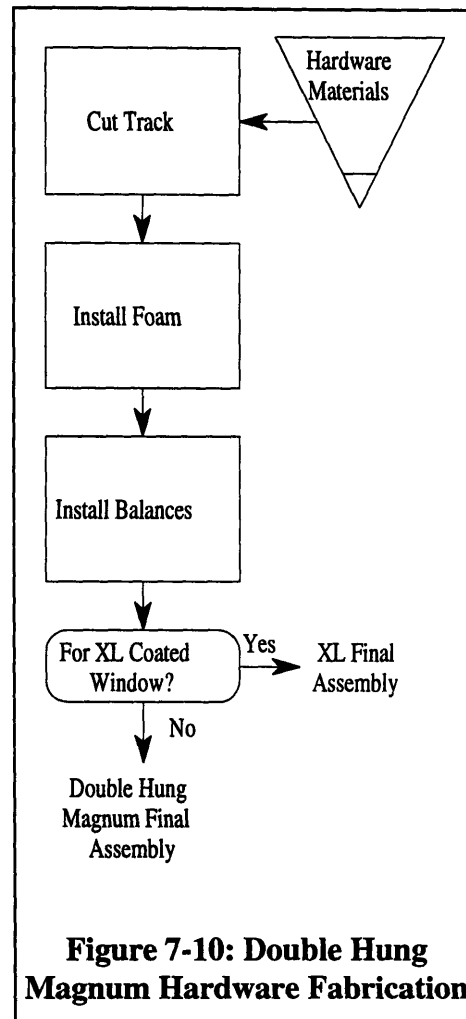
If the frame is to be primed on one side only, a P2 coating as it is called, it is done manually in the department. P3 coated windows, or primed both sides, are sent out for priming. If the window requires an XL coating, it is sent to the XL department. Next, the jamb liner is installed in the frame. Pilot holes are then drilled for the hardware, and the pre-assembled hardware is attached. Finally, the sash are installed.

#### 7.4.2.2 Double Hung Magnum Hardware Assembly

Since all Double Hung Magnum windows are specials, hardware must be custom fabricated for each unit. For example, each sash must be counter balanced with the correct spring tension, which depends on the weight of the sash. Special Calcs computes the balance size for each window. The worker must rely on the information contained on the order sheet (especially the information supplied by Special Calcs) to instruct him how to build the subassembly.

As shown in Figure 7-10, hardware fabrication begins with the pulling of the correct component parts, which are inventoried in the department. Then, the track is cut to the correct length. Foam installation occurs next, followed by the assembly and installation of the balances.

The hardware assembly is then routed to the place where it will be installed in the window. If it is part of an XL coated window, it is sent to the final assembly area in the XL department. Otherwise, it is routed to the final assembly area in Double Hung Magnum.



**Figure 7-10: Double Hung Magnum Hardware Fabrication**

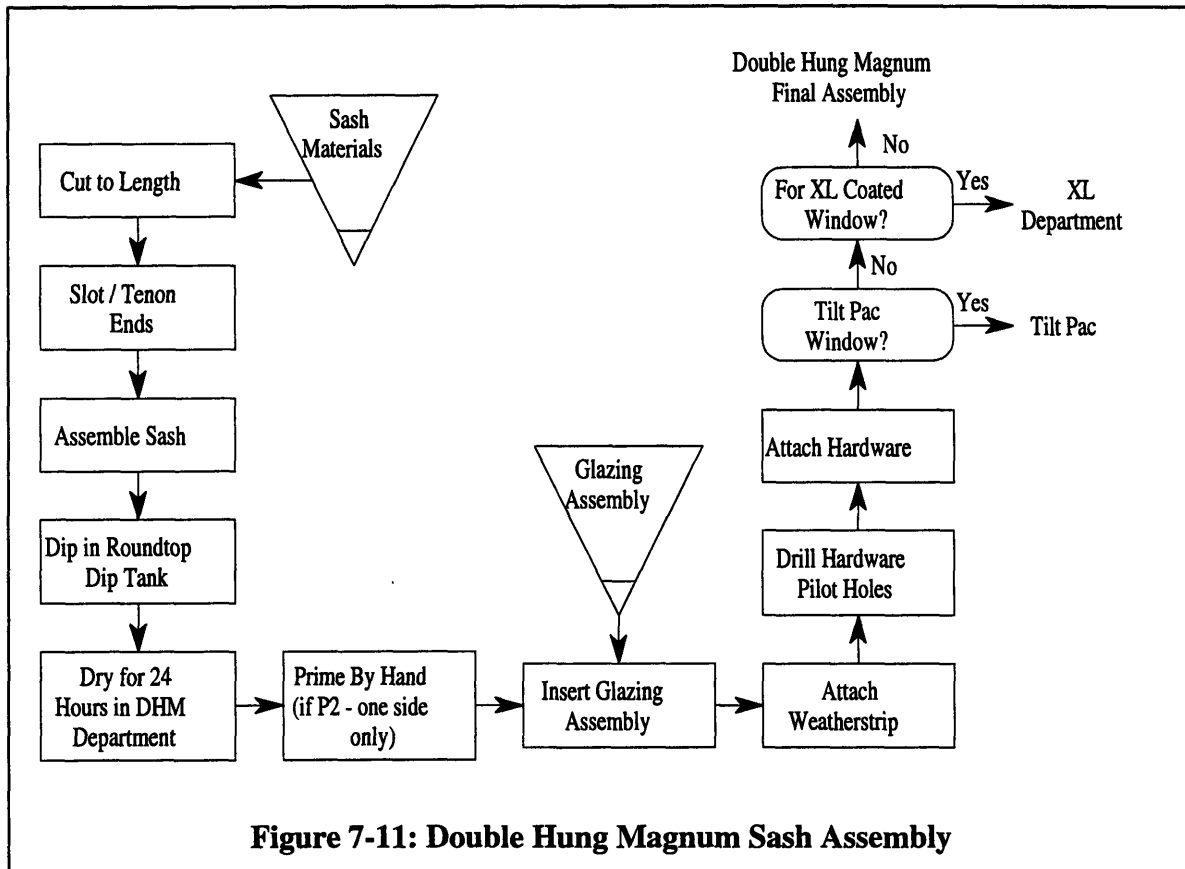
#### 7.4.2.3 Double Hung Magnum Sash Assembly

Sash assembly proceeds in much the same way as frame assembly. First, sash materials must be pulled from department inventory. The lumber is then cut to the required lengths, as described in the Special Calcs information stapled to the order sheet. The ends of the sash parts are then slotted or tenoned, and the sash is assembled.

As is the case for Double Hung Magnum frame assemblies, the sash assemblies are sent to the Roundtop department to be dipped in a preservative solution. The sash frames are returned to Double Hung Magnum to dry for twenty-four hours. Priming of the sash occurs next. P3 coated windows (primed both sides) are sent out, while P2 windows (one side only primed) are manually primed in the department. The glazing subassembly is

inserted next, and weather-stripping is attached. Once the pilot holes are drilled for hardware, the hardware is attached.

The sash must be routed to the location where it will be installed in the window. If the window is part of a Tilt Pac, it is sent to the Tilt Pac department, where it is packaged. If it needs to be XL coated, it is sent to the XL department, where it is coated and final assembled. Otherwise, it is routed to the final assembly area of the Double Hung Magnum department.



In summary, the Double Hung Magnum department is responsible for assembling only special sizes of windows. It responds to this need for flexibility by providing almost all of the machines needed for production within close proximity in the department. Information is transferred to the shop floor workers via the order sheets, which of course have been augmented with information from Special Calcs.

This job shop approach requires workers to be sufficiently skilled that they can determine how to build the window from the specification provided in the order sheet, including routing the subassemblies to the correct locations. Even though all sizes are special, the product type is sufficiently constrained that this process planning function is easily performed. However, there is considerable effort expended in coordinating and tracking work in process within the department, to insure smooth production flow.

### 7.4.3 Special Glass

For most standard sized windows, precut glass is purchased from vendors. However, some standard sizes and all special sizes of glass are cut in-house from large sheets of glass. The special glass department maintains an inventory of large sheets of different types of glass. Standard sized glazing assemblies are inventoried in the different departments and are ordered from the glass department according to a reorder point system.

There are three computer controlled glass cutting machines used at Marvin. Two identical machines built by DeMichaels are used exclusively for cutting rectangular shapes. The third machine, called the X-Opt machine, is used to cut all non-rectangular shapes — curved glass and glass with non-right angles.

#### 7.4.3.1 Rectangular Shaped Glass

Most of the rectangular shaped glass is for Casemaster windows. The flow of these orders was tracked through the department. In window scheduling, orders are received and separated by shape, color, glass type, and glass thickness. This is necessary because several orders (of the same glass) are cut simultaneously from one of the large sheets of glass. In addition, all cuts of one type of glass are performed before switching to another type, since there is a setup procedure required. Each type of glass sheet is stacked on a separate cart. In preparing the DeMichaels machines for production, the correct cart must be positioned alongside the feeder conveyor. The sheet is then manually dropped onto the conveyor.

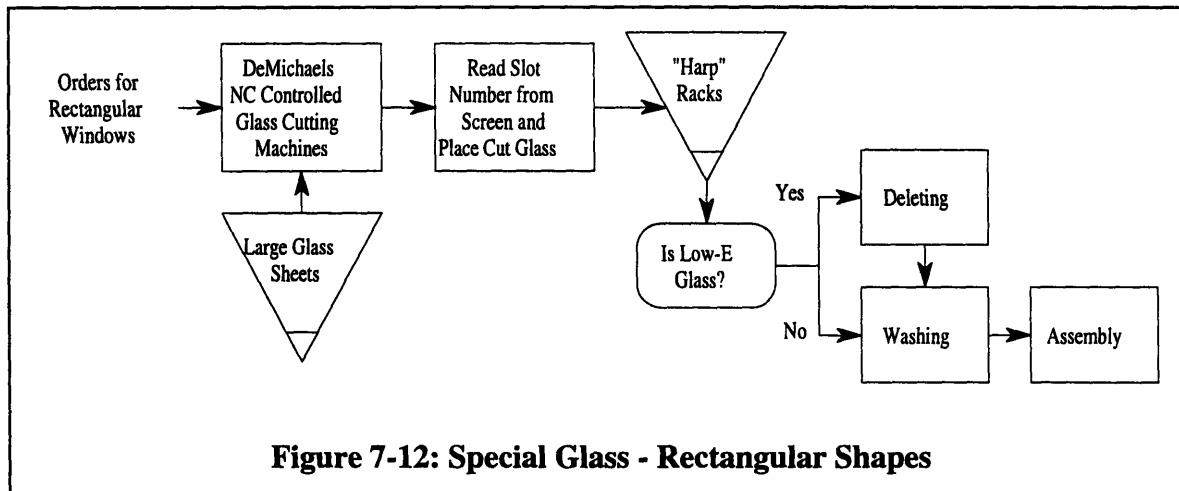


Figure 7-12: Special Glass - Rectangular Shapes

Order information has been entered into the VAX computer system by Casemaster order processors. Information from the VAX is merged to the PC controller on the DeMichaels machines by downloading a file from the network. The operator knows which file to download from the coordination sheets sent from Casemaster or Casemaster Clad. Inputs to the DeMichaels control software include the length, width, and type of glass, the department, the order number, the truck number, and the number of pieces.

As described above, large sheets of glass are manually placed on the table and the machine automatically positions the glass at the origin of the coordinate system. The machine's controller optimizes the cuts to maximize the yield from each sheet of glass, and the machine scores the glass. Workers break the pieces out of the scored sheet and place them in a slot of a "harp" rack. The harp rack is a cart with many numbered slots. Placing the glass in a specific slot effectively sorts the output into the order it is needed at the next processing step. Since the system optimizes output based on glass yield, the output order from the machine is not sequential. The worker consults a computer monitor above the table to determine which slot is the correct one. It shows the entire sheet of glass with lines representing the cut shapes and numbers centered in each shape's outline representing the number of the correct slot on the harp rack.

If the glass is low-e coated and has an edge that was an outside edge of the large sheet of glass, it then goes through a deleting process. Deleting removes the coating from the outer edges of the glass. On each shift, low-e glass is cut first since it requires this extra step.

Rectangular glass cutting is an example of how design information can be used to improve production. Although the information is reentered manually into the VAX system, it is downloaded from there and used by both the optimizing computer to maximize material yield and by the workers to facilitate a complex sorting job.

The rectangular glass cutting operation could be further automated by the introduction of a material handling robot to automatically load the feeder conveyor. There would be several benefits to automating material handling. First, the robot would receive commands from the DeMichaels controller as to what type of glass sheet was needed. The glass sheets could be stacked in bins at predefined locations. Thus, the robot could retrieve any type of sheet at any time without a penalty for setup, so batching all orders of the same type of glass would be unnecessary. In addition, the robot would virtually never break a sheet while loading the conveyor. While this reportedly is not a serious problem, it does occur.

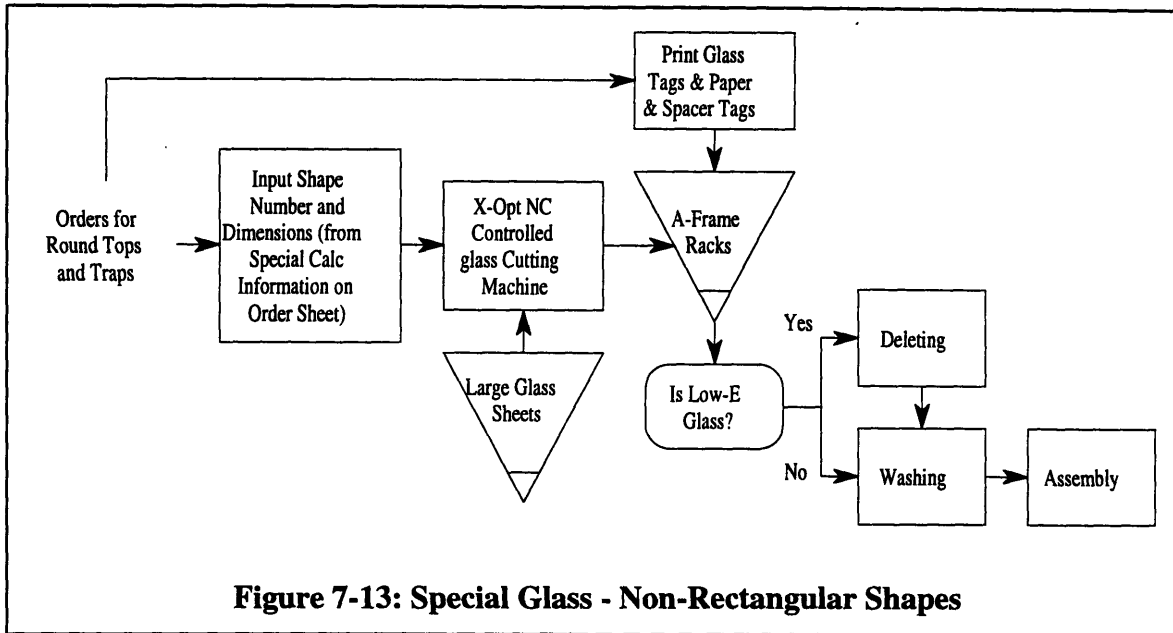
Since the information processing infrastructure exists in this area of the plant, the cost of implementing such a system is confined to hardware costs. There would be no additional cost associated with entering process planning data for the material handling system. The necessary information is available from the DeMichaels controller.

#### ***7.4.3.2 Non-Rectangular Shapes***

Orders from Round Tops, Traps, and Double Hung Clad go through the departments and are sent to Special Glass at the beginning of each day. For each piece of glass required, the operator must input the shape number and the dimensions into the machine controller. This data is contained on the Special Calcs attachment to the order sheet.

As is the case with the DeMichaels machines, the X-Opt machine is manually loaded and automatically scores the glass. The output from the machine is placed on a standard

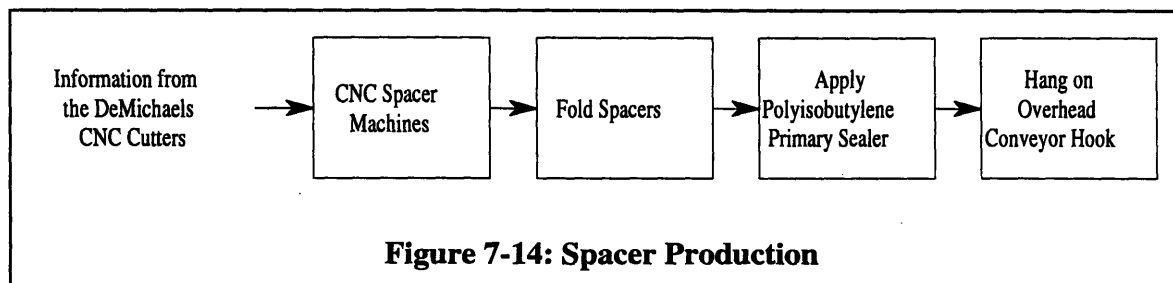
A-frame cart with the corresponding glass tags and spacer tags, which identify the part. Again, low-e glass is cut first and is sent to the deleting process.



Glass from both the harp carts and the A-frame carts is then placed in one of several washing machines. As it exits the washer, it enters the assembly area of the department. Thus, it is critical that pieces of glass enter the washer in the exact order that they are needed by assembly.

### 7.4.3.3 Spacer Production

Spacers are the aluminum pieces that fit between the two sheets of glass in a double glazed window. They are fabricated from rolled aluminum strip on machines that cut the strips as needed and fold them into C-shaped channels. For special glass that is cut on the DeMichaels machines (rectangular shapes), information is downloaded directly from the DeMichaels CNC controllers to the controllers for the spacer machines and they are fabricated in the order that the glass is to be placed on the harp cart (so they reach assembly simultaneously).



Spacers for glass cut on the X-Opt machine are fabricated in one of two ways. Spacers for Roundtop windows (all curved glass) are made by hand. Spacers for Traps are made by the spacer machine. The operator must enter into the controller the necessary information,

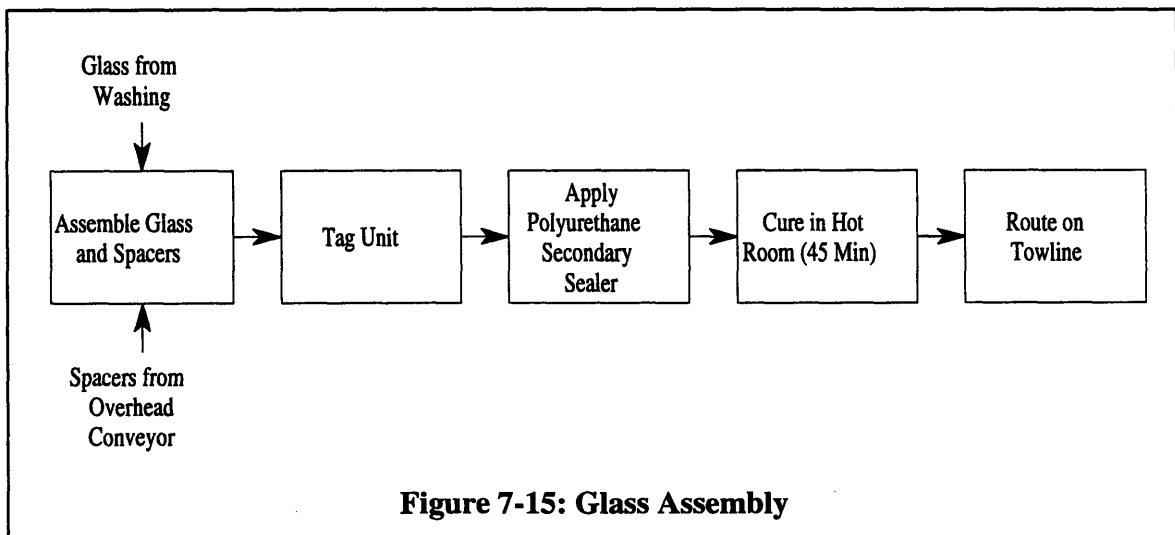
which was computed by Special Calcs and is contained in the order sheet. Much manual effort is then expended to coordinate the simultaneous arrival of the spacers and the glass for assembly. Spacers must be made in a particular order based on the order that glass was placed on the A-frame carts, since it will exit washing in order.

After spacers are fabricated by the machines, they are manually folded into the shape of the glass. A polyisobutylene sealer is applied to both sides of the spacer and they are placed on an overhead conveyor that leads to final assembly.

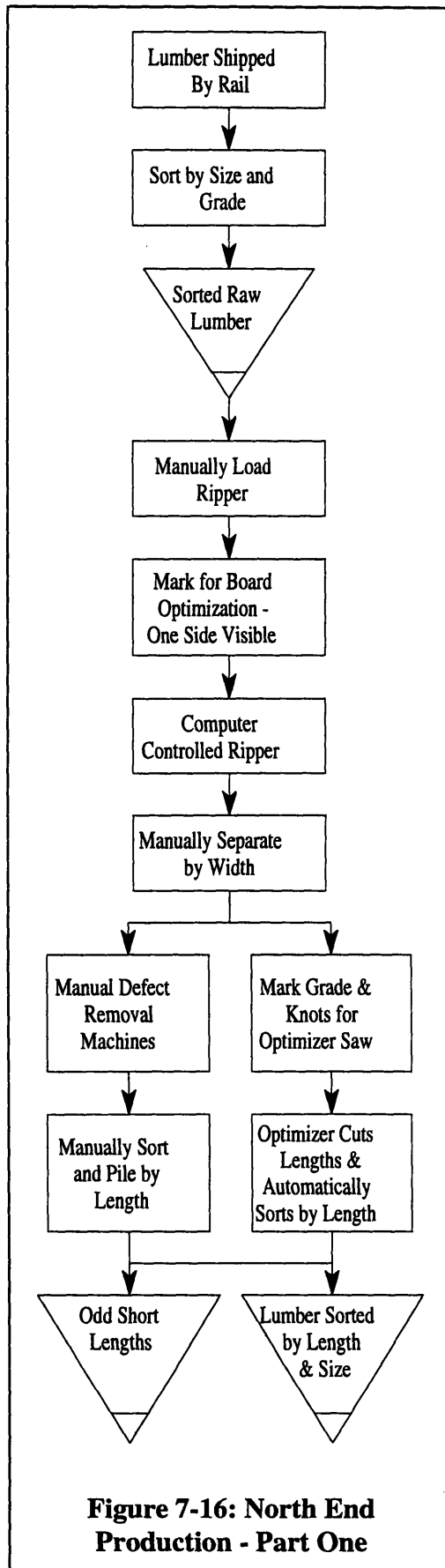
Clearly, spacer production provides another example of where design-manufacturing integration leads to benefits. It clearly shows, by contrasting the two methods, that automatic production coordination is much easier and more accurate than manual production coordination. Such coordination is made possible by integrating design information (spacer size) and production information (just in time scheduling and control of production and subsequent coordination of part routing).

#### **7.4.3.4 Special Glass Final Assembly**

The final assembly process in special glass is an assembly line that combines the cut pieces of glass and the spacers. As alluded to above, the most critical factor for smooth production flow is the simultaneous arrival of washed glass and fabricated spacers. Once assembled, the unit is tagged with its routing, its order number, and its truck shipment number. A secondary polyurethane sealer is then applied and it is heat cured for approximately forty-five minutes. When cured, the unit is routed on the towline to the correct department.



**Figure 7-15: Glass Assembly**



**Figure 7-16: North End Production - Part One**

#### 7.4.4 Parts Production

The North End, as it is called, is the area in the factory that converts raw lumber into finished wood components to be used in window assembly. In addition to lumber storage, there are two production departments in the North End: Rip and Cut, and Milling.

Because of the highly volatile nature of lumber prices, Marvin buys lumber as a commodity, purchasing large quantities when the price is low and storing up to 11 million board feet of it.

##### 7.4.4.1 Order Receipt

Long setup times force large batch sizes, which in turn increase throughput times and lead times. Currently, orders are given to the North End shop from the scheduling office roughly every two weeks. At one time, orders arrived monthly. In either case, batch sizes are large due to significant changeover and setup times.

Orders given to the North End include a shop drawing of the final part shape. This information is required for milling. However, workers in Rip and Cut suggested that they should also receive a shop drawing showing the outline of the part before milling. Therefore, they would know how to fabricate a rough shape that can be milled into the required part. Reportedly, a significant amount of time and effort is spent process planning to determine this, and they sometimes lack the required expertise about complex milling operations. This type of information can be rather easily computed with a computerized design system, and through design-manufacturing integration, it can be automatically transferred to production.

##### 7.4.4.2 Rip & Cut

The component production process is shown graphically in Figure 7-16 and Figure 7-17. Lumber is first unloaded from rail cars with fork lifts. It is sorted by size and grade, and stored in

the warehouse. As needed, the lumber is moved by fork lift from the warehouse to the ripping machine's staging area. The ripping machine is loaded manually by placing boards on a conveyor. The board is marked for optimization when the conveyor advances. This is done by moving shadow lines over the board so that they miss the major knots and imperfections in the lumber. The board is then automatically ripped by the computer controlled ripper at the locations of the shadow lines. Roughly eighty thousand board feet of lumber can be ripped per shift, and up to eight sizes can be ripped simultaneously. Output from the ripper is then manually sorted by width and is sent through one of two processes for cross cutting: manually operated machines and computer controlled optimizer saws. The cross cutting removes the knots and other imperfections in the lumber.

The computer controlled optimizer saws are highly efficient machines that optimize the output of each board based on the location of knots and imperfections and a schedule of needed board lengths. Orders from machine scheduling are loaded into the optimizer computer for every shift changeover, or twice daily. Disks can be used to download the required information ("a sneakernet," in computer-ese), or the needed information can be manually entered. The entered information includes: the required sizes, the dollar values of each size, and the number of each size needed. Manual data entry takes roughly ten minutes to do (for each shift).

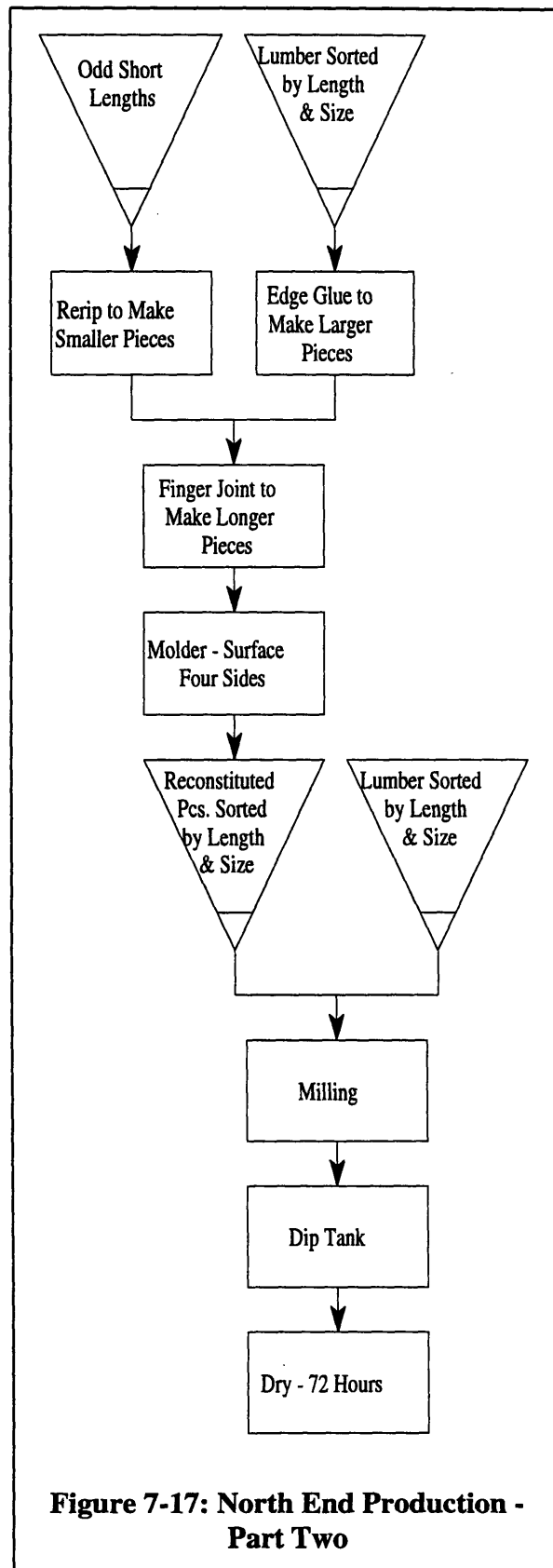
Once the data is loaded, production begins. Lumber is fed onto a conveyor. As each piece passes a worker, the worker marks the piece with a special marker to identify the imperfections. The worker uses a group of mirrors to see all four sides of the board simultaneously. The machine then optically reads the markings on the piece and in real time it optimizes the output of the piece based on required sizes. The optimal cuts are then made automatically. Each of the pieces is then automatically conveyed to a series of bins, according to size.

Marvin operates two optimizer saws, each of which processes between 35,000 and 40,000 lineal feet per shift, depending on the grade or quality of the lumber (lower grade lumber requires more cutouts). The optimizer saws have yielded many benefits. There has been a four percent increase in material yield, from fourteen percent waste to ten percent waste, and a 250 percent increase in speed. In addition, workers are required to do less manual lifting.

The optimizer system reports the material yield and the value of pieces cut in real time for each piece of lumber. In addition, it generates summary reports. Marvin prints "period summary" reports three times per shift and a shift summary report at the end of each shift.

The optimizers are highly automated, sophisticated pieces of equipment. They replaced simpler, manually operated machines. However, Marvin still operates several of these manually operated machines as well. They operate in much the same way, only slower and less precisely in terms of material yields. In addition, the output must be manually sorted by length.





The output from both types of machines can be classified into three groups: defect-free lumber that has been sorted by length and size, unusable pieces that can be reconstituted into useable pieces, and waste. Those pieces that can be reconstituted into useable pieces are fed back to be re-ripped and edge glued (to make wider pieces), and/or finger jointed (to make longer pieces). The reconstituted pieces are then resurfaced, cut to usable lengths and veneered. This process maximizes wood utilization.

#### 7.4.4.3 Milling

The other department in the North End section of the plant is Milling. Milling receives a scheduling sheet from North End scheduling on a daily basis. However, schedules are regularly adjusted by the Milling department to reassign jobs to different machines based on performance, output, etc. and to accommodate special orders.

When the job is being prepared to be run, the operator must first determine the configuration of the machining head (the number, shapes and sizes of knives) and the number of hold downs required for the piece. The head description is hand delivered to machining, which retrieves the head, if it is already assembled, or assembles it if not. Heads are kept in machining because the knives require sharpening periodically and some of the knives are used in multiple heads.

Setups are more critical in Milling than in Rip & Cut since the required tolerance is seven thousandths of an inch, compared to 1/16 inch (62.5 thousandths). Once the head is retrieved and installed on the machine, fine adjustments must be made to achieve tolerances. Setups take between

3.5 and eight hours, depending on the complexity of the part, whether or not the part is a special profile, and how well the machine has been maintained. Machine maintenance is critical to achieving tolerances quickly. To measure tolerances, the operator makes a part, cuts a cross section of it, and uses an optical comparator to match it with the specification. The comparator optically enlarges the outline of the piece and superimposes a transparent mylar sheet that contains an accurate shop drawing. Required adjustments can be measured and the cycle repeats. On average, roughly thirty-five non-conforming parts are made before the required tolerances are achieved.

When milling is completed, parts are dipped in a dip tank. Cartloads of pieces are dipped in a preservative solution. They then must dry for seventy-two hours. Management is currently evaluating an in-line dip system that would dry parts in two minutes.

## **7.5 Summary and Conclusions**

### **7.5.1 Information Flows**

On the shop floor, two kinds of information are needed: what to make next and how to make it. What to make next depends on the shipping schedule. Information on how to make it is contained in several locations: on the order sheets, on the Special Calcs attachments to the order sheets, on the header labels, in the routing information, and in some cases, on the computer network. All of this “how-to” information is really the process plan, although it is never referred to in that way. Process planning at Marvin has grown to be somewhat of a hodgepodge of legacy systems and manual patches that are made to work — for the most part. However, there seems to be a lack of vision as to how the system should or could work if the systems designers were starting from scratch.

The real source of the problem stems with the order entry system and its lack of integration with downstream operations. The actual plant floor operations work surprisingly well with the paper flows of information, in part because each process step requires only a small amount of information. Information overload does not occur. However, there is an extremely large amount of data reentry and inefficiency in order entry and order processing. First, any time information is to be downloaded to the shop floor electronically, it must be reentered into the VAX network. Second, Special Calcs seems to be relatively expensive and inefficient. These calculations should be automatically generated from the design information. With the legacy systems, automation of Special Calcs seems difficult if not impossible. However, this code could be easily integrated with the design system or the MQS. The problem with integrating into the MQS is that not all window orders are MQS compatible. This information belongs in the design package. Thus, at the completion of window design, a complete specification will exist. Further, routing information and other information required for the process can be integrated into the design system so that the integration from design to production is seamless and error free.

### **7.5.2 Shipping vs. Due Date Scheduling**

No one at Marvin Windows seems to really want shipping to drive production. They would prefer due date scheduling. Due date scheduling means that they can promise the customer delivery by a certain date. Production would be scheduled by minimum float time or orders could simply be processed when they are received. In either case, odd shipments would be formed at the end of the line. Finished goods inventory would accumulate and could become damaged or lost. The real source of this problem is not the fact that shipping controls production. Rather, *the shipping department is inherently inflexible*. This inflexibility is due to two sources: an inability to do robust real time routing optimization; and, the rigid shipment size of the large trucks.

On the other hand, Shipping has justification for what they do. Large trucks are efficient for long hauls. Shipping costs roughly \$1.10 per mile, totaling a mere one percent of invoice. According to the consultant's study, that is five percent lower than the industry standard. However, the question for Marvin's top management is "Does minimizing shipping cost maximize profit?" It may be useful to look at the total system, since Marvin's made to order operation is so different from most other industries.

The optimal system might be a real time routing optimization system in which orders are routed to bins in real time as they come off the line. When an economically optimal load was ready (probably composed of several stops), loading would be signaled and the truck would be sent. Rules could be used to maintain maximum waiting times, optimize routing, etc. A total logistics study should be undertaken to determine whether or not the entire production and supply system is optimal. Perhaps a second factory or smaller localized factories would be better. It is also possible that smaller trucks could be used to deliver straight to the site, or the large trucks could make many stops at jobsites. In any case, it is well beyond the scope of this Thesis.

### **7.5.3 Conclusions**

Marvin's operation shows several real world examples of design-manufacturing integration targeted at islands of automation throughout the shop floor. They have improved material yields with the optimizer saws and the CNC glass cutters. They have improved coordination and control in glass assembly. Overall, they have increased efficiency and flexibility. However, the systems have been production driven, and have been forced into the overall process with data reentry and other patches. Thus, automated downloading of information to wood cutting machines, which they could potentially do, is not done. Likewise, the coordination of special glass for the Casemaster Clad department is not nearly as effective as the coordination of glass and spacers in glass assembly. Marvin faces a real opportunity to integrate design and manufacturing and thus create an information infrastructure that would support the proliferation of automation in production planning, coordination, and control throughout the plant.

Marvin lacks the total solution, due in large part to their dependence on legacy systems, and their inability to update these to current technologies. In spite of this, they remain a strong example of flexibility and efficiency in off-site production.

#### **7.5.4 Suggestions for Improvement**

One barrier to increased design-manufacturing integration is the lack of a robust design representation. A more robust representation for window design is possible due to the inherently object oriented nature of the kit of parts used to manufacture windows. As described earlier in the Chapter, a hierarchy of constituent parts, or class composition hierarchy, can be developed that encompasses all possible windows. In addition, we can define a class hierarchy, which depicts the similarities and variations of parts that comprise the kit of parts, as well as the rules governing the valid combination of the parts.

The advantage of an object oriented representation is that it provides the framework for a much richer description of the window than simple sizes and attribute information. Process parameters and other richer forms of manufacturing information such as shop drawings can be represented for each constituent part. Also, process planning information can be defined for each object in the parts hierarchically. Thus, the interpretation that is required for process planning is simplified.

The result in simple terms is that the generation and distribution of the information needed for manufacturing can be more easily automated and the system will be robust enough to encompass *all* possible windows. Thus, savings can be captured at all stages of the process. The pre-production order processing and routing can be automated, eliminating data reentry. All necessary information will exist on-line, so shop floor departments can think about what information they really need to improve production and how they can use the information to become more automated. In essence, an information infrastructure is created in the organization. The next Chapter describes a prototype system that demonstrates the viability of this approach.

## 8. Process Planning for Off-site Production in Homebuilding

Manufacturing systems consist of both material and information processes. Robust information systems enable machines and/or people (the material processors) to manufacture a wide range of products by providing them with instance specific information which is used in production. Instance specific information is any data or information which describes how a production process should vary to make a given part. Further, information systems can deliver these instructions to people “just-in-time,” eliminating the possibility of information overload. Automating the generation and flow of information with computers provides this functionality. Flexible manufacturing systems do not necessarily require automated machines or robots, although automated information processing is essential for efficiency and flexibility.

This chapter presents an approach for automating the generation of process information and describes a prototype system for window production. The prototype system focuses on the generation of information required for production. The means for distributing information just-in-time is well established and so is not discussed.

### **8.1 Introduction - Planning for Multiple Production Resource Types**

As described in Chapter Five, Manufacturing process planning has typically focused on generating CNC code for automated machining operations. The objective of such low level planning is to automatically generate machine movements, feed rates, tool selections, and other machine specific information. Benefits include higher productivity, more consistent plans, and shorter planning times. Assembly planning and construction planning are higher level planning tasks and have focused on generating task lists and precedence relationships from rules, heuristics, and/or first principles. Human workers typically interpret high level process plans to determine how to perform specific work tasks. Neither type of process planning is sufficient for process planning in off-site production in housing.

Low level planning systems have been limited to operations performed on numerically controlled machines. Nordland recognized this limitation and stated that future process planning systems should communicate with workers as well.<sup>1</sup> High level planning systems focus on tasks and precedence relationships between tasks. In off-site production of housing or components, the precedence relationships and required processing tasks are well defined for the individual objects in the kit of parts. In fact in most cases, process plans are variations of predefined plans. An instance-specific process plan must be

---

<sup>1</sup> Nordland, Gerald L., “Integrating CAPP into Factory Management Systems,” *Manufacturing Systems*, February, 1985.

generated for the assembled component as well as for the individual parts. In addition, the planning system must accommodate a wide range of production resources, from fully automated computer controlled machines to human craftspeople. The approach described in this chapter recognizes that off-site production in homebuilding requires multi-level planning for a wide spectrum of resource types.

In contrast to manufacturing processes such as machining, off-site assembly for housing is well defined regardless of the batch size. Since production frequently utilizes special purpose machines, a planner typically has only a single potential production resource to allocate. In contrast, a process plan for a machined metal part will include a choice of machine or process that will differ based on the batch quantity and or delivery schedule.<sup>2</sup> This is important because it further simplifies the process planning problem.

The approach to off-site process planning described here allows the generation of a process plan for any valid design configuration. The approach captures the well-defined rules of assembly for the kit of parts as well as factory-specific manufacturing process constraints. Valid design configurations can be determined and assured using rules-based or object-oriented constraint-based configuration technology.

Since the process plan is well defined for specific component objects, an object-oriented approach can be used to encapsulate the planning algorithm within each object class. The instance specific plan can then be generated using the data stored in the objects. The structure of the kit of parts and the information requirements of the production resources together determine the structure and information content of the object hierarchy.

Section 8.5 describes an implementation of the approach for window manufacturing. The implementation targets window manufacturing for four reasons:

- the case study provided valuable information about the production processes;
- several window manufacturers have begun to utilize computers in design, so digital design data is available;
- windows are a complex assembly of objects, but are based on a kit of parts;
- window manufacturing requires numerous types of production resources, typical of off-site production of components for housing.

Since a *factory-specific* set of resource constraints must be represented in the class hierarchies, this chapter depicts a hypothetical window factory and a hypothetical kit of component window parts. They are based on the case study described in Chapter Seven. The types of data and information that are required at each step in production are described. This production information will form the basis of the process plan. Finally, the prototype system is presented.

---

<sup>2</sup> Nordland, Gerald L., "Integrating CAPP into Factory Management Systems," *Manufacturing Systems*, February, 1985.

## **8.2 Functional Requirements of CIM Software for Off-Site Production in Housing**

There are two primary functional requirements that a CIM system must satisfy to be useful for off-site production in the housing industry. First, the system must provide an easy to use, productive design environment. Second, the system must yield a productive manufacturing environment.

### **8.2.1 The Design Environment**

A productive design environment must have three capabilities:

- the ability to create and view designs (assemblies of predefined objects);
- the ability to create and store new objects or component parts;
- the ability to verify the manufacturability or producibility of the design.

#### *8.2.1.1 Graphical Representation of Objects*

In the AEC (architecture, engineering, and construction) industry, existing CAD systems are capable of creating and storing graphical representations of designs and component objects. In fact, commercial CAD systems exist which allow designers to define dimensions and geometry parametrically. Thus, geometry can be constrained in predetermined ways. Parametrically defined geometry is the most useful representation for a component object. If dimensions are defined in terms of other dimensions, a designer can stretch or shrink an object without altering other dimensions in undesirable ways. For example, if a window is designed to fit a rough opening of fifty inches wide, and the jambs are two inches thick on each side, the glass width can be defined as the rough opening less the right and left jamb widths. Therefore, if the designer changes either the rough opening, left jamb, or right jamb widths, the system will automatically update the glass object's width.

ProEngineer from Parametric Technology Corporation is a commercially available CAD system with solid modeling capabilities as well as the parametric graphical design capabilities defined above. In addition, it has the ability to model assemblies of objects. AutoCAD®, from the Autodesk Corporation, has also recently implemented a parametric design module, AutoCAD® Designer. Although AutoCAD® is the leading CAD system in the AEC industry, its parametric design module is not nearly as robust as ProEngineer.

CAD systems are typically limited to a graphical representation of the design, but may include attached attribute data. Hence, with commercially available systems, all data and information to be represented must be tagged to graphical objects through the attributes. This representation fails for two reasons: it doesn't provide a convenient mechanism for representing manufacturing or other procedural data required downstream; and, it is difficult to represent complex relationships with simple attributes. So while the available systems can be used for creating and storing objects and assemblies, CAD systems provide no mechanism to model the interactions between the components or the necessary manufacturing information. Therefore, a more sophisticated model is required for design verification and to represent the production process.

### 8.2.1.2 Design Checking / Verification of Manufacturability

Design verification ensures the manufacturability or producibility of the design, as well as verifying that design constraints are satisfied. For example, in window design large lites require the use of tempered glass to satisfy safety requirements. The system must be able to check the size of the lite and if it exceeds the limit, it must check the type of glass it contains. Non-conforming glass should raise an exception to the designer. In addition, the system should verify manufacturing constraints such as the maximum and minimum part sizes that can be produced by different production resources, the available finishes and styles, etc. When exceptions are raised, the system should recommend possible solutions, automatically correct the error when appropriate, and automatically implement valid options selected by the user. Configuration software can validate designs in this manner. For example, the Marvin Quote System contains a rules-based order validator that will signal the designer if a window size or option is invalid.

Configuration and validation software is commercially available. Such systems configure and validate complex products based on rules or constraints which govern the interactions between parts. There are two approaches that are commonly used. First generation systems were rules-based validators. Marvin Windows utilizes a system of this type. Also, virtually every commercially available MRP system has a configuration module that utilizes a rules-based approach.

Rules-based configuration systems simply declare how components in the kit of parts can and cannot be combined. It is not the most flexible or useful approach, but for small problems it is much easier to develop the configuration model since it is not necessary to model the underlying phenomena that cause the interaction constraints. For example, a simple configuration rule for a product might be that window locks cannot be used with polygonal windows, while a rule regarding the production process might be that polygonal glazings with angles smaller than twenty degrees must be fabricated in the custom glass department. No understanding of what causes the design or production constraints is required.

Rules-based systems are good for small problems because they are relatively easy to develop. However, the number of rules grows rapidly for large problems, so system development is difficult. If only first order interactions exist, the number of rules would be  $O(n^2)$ , where "n" is the number of parts. If there are higher order interactions, (this depends on that, but not when the other is present), then the number of rules explodes rapidly. Moreover, since new part definitions require a large number of rules to be written, new product flexibility is actually hindered for large rules-based systems.

Second generation systems utilize an object-oriented, constraint-based approach and were designed to solve more complex configuration problems. Constraint-based configuration models utilize rules (constraints) on *classes* of objects to control the interactions between the components. Thus, one rule on a class replaces many rules on individual components of that class. The structure of the problem is exploited. For the example above, the corresponding product constraint might be that window locks can only be installed on



operable windows (defined as instances of the class “operable window” or any classes that are derived from the class “operable window”). Since polygonal windows are not operable, the correct behavior would result. Likewise, the process constraint corresponding to the rule described in the above example might be that a particular automated glass cutting resource is only capable of accurately cutting angles more than twenty degrees. Thus, any part with an angle smaller than twenty degrees would search for an alternative production resource to meet its production requirement (the custom glass department).

Object-oriented configuration models can be more difficult to develop for two reasons: the hierarchical structure (class hierarchies) must be defined; and, the underlying causes of the design and/or production constraints must be understood. However, this type of configuration model is more flexible because it more easily adapts to future product and process changes. Simply defining a new part as a member of a particular class defines most of its behavior. For example, if the automated glass cutting machine referred to in the above example was replaced with an improved model that was capable of cutting angles down to five degrees, the process plan would be correctly generated, routing the appropriate parts (with angles as small as five degrees) to the new machine.

### 8.2.1.3 *Beyond Graphics*

It should be noted that configuration systems are not inherently graphical. Moreover, there is no requirement that the design interface have graphical capabilities, and unless geometry must be constrained at design time, design validation systems can be purely data driven. In fact, all of the MRP systems have text based configurators and define geometry by the specification of dimensions and sizes.

There are often several types of interfaces that can serve the purpose of data entry and design creation equally well. When the interface is primarily graphical, it is often referred to as intelligent CAD. Intelligent CAD, or ICAD, is the concept of linking additional functionality to a CAD system. An ICAD system represents more than just geometry. It can include information representing function, behavior, relationships between components, features, manufacturing constraints, and other attributes.<sup>3</sup> Essentially, intelligent CAD consists of a configuration system built on top of a CAD system. Intelligent CAD systems linked to relational databases have been used to accomplish tasks such as the evaluation of manufacturing costs and the validation of a design for compliance with the building code.

---

<sup>3</sup>Brown, David C., "Emergent Themes in Intelligent CAD," *Intelligent CAD, III.*, Elsevier Science Publishers B.V. (North-Holland), 1991.

Clearly, a solid model by itself is an insufficient representation for ICAD,<sup>4</sup> since all the information that is useful to generate cannot be derived from the geometry alone. Modeling manufacturing processes or manufacturability in an ICAD or CAPP system requires the representation of production plans, manufacturing process models, resources, and models of raw stock.<sup>5</sup> There are many ways to model behaviors, including configuration spaces, rules, causal modeling, physics, and constraint propagation. Since the kit of parts and the manufacturing environment are well defined and are inherently object-oriented, an object-oriented representation is a natural choice, coupled with parametrically defined constraints or rules which govern the behaviors of objects and classes of objects. In any case, some form of an integrated database is required to control information flow between design and manufacturing.

Both ProEngineer and AutoCAD can be extended and customized. It is feasible to design a specialized interface using either of their development tool kits. The result would be a means for generating and assembling objects. In addition, the interface would provide a link to an external database that would store all non-graphical data. In fact, some commercially available systems have done just that. For example, there is a product called *ICAD*, from the Concentra Corporation, that integrates a proprietary CAD system with a Lisp modeling tool that can be used to model interactions between components. Product configurations can be validated by the system. A process planner could then be used to interpret the design data to generate a process plan.

The choice of a graphical or non-graphical interface depends on what type of product is to be modeled and how much geometric data is required to create the design and to generate the information needed downstream. In addition, it is important to consider the level of knowledge of those who will be performing the design task, as well as system ease of use. CAD-based interfaces are more expensive to develop and more complicated to use. For the flexible manufacture of windows, with the producer providing an electronic link to the builder, the design will typically be generated by a builder or architect. For builders, an easy-to-use, non-CAD interface is most appropriate, while a CAD interface would be more familiar to architects.

Marvin Windows has addressed these needs directly with their Marvin Design System. As described in Chapter Seven, the primary interface is a menu and button driven Microsoft Windows interface, which will be easy for builders to use. In addition, the system can integrate with AutoCAD for generating complex shapes, a task more likely to be performed by an architect than a builder. It should be noted that in either case, the design tasks are typically concerned with defining high level options and styles. Detailed

---

<sup>4</sup>Arbab, Farhad, "Design Object Representation" *Intelligent CAD, III.*, Elsevier Science Publishers B.V. (North-Holland), 1991.

<sup>5</sup>Arbab, Farhad, "Design Object Representation" *Intelligent CAD, III.*, Elsevier Science Publishers B.V. (North-Holland), 1991.

design tasks like the generation of a bill of materials can and should be automatically performed by the system.

### **8.2.2 The Manufacturing Environment**

A CIM system can yield a productive manufacturing environment if it can automatically generate and distribute all types of process information throughout the factory. Furthermore, information should be available on a just-in-time basis. Computer aided process planning is the link that integrates the design system with the different production resources and the other information systems throughout the plant. Thus, the CAPP subsystem of a CIM system should have some or all of the following capabilities:

- The ability to automatically generate a bill of materials, including a task list and production sequence for each component or subassembly;
- The ability to automatically generate cell level machine commands (or integrate with a post-processor that does);
- The ability to automatically generate and distribute cell level instructions for human production resources;
- The ability to integrate with systems that manage production, including tracking and controlling work in process, controlling inventory, scheduling production, and controlling production costs and resource utilization.

MRP systems are typically used to manage production. As described in Chapter Five, the inputs to MRP systems include a detailed bill of materials, task sequences for each part, routing information, and time standards for each task. Thus, MRP systems require as input the information generated in the first item above. Machine level commands are essentially more detailed (lower-level) representations of the process task list. Typically post-processors are used for low level planning because they are machine specific. Although G-codes and M-codes are theoretically uniform, the reality is that their implementations by machine tool manufacturers have differed slightly, so post-processors are almost always required.

The process planning problem becomes how to represent the manufacturing process within the object-oriented kit of parts. In other words, the parameters, constraints and/or rules used to automatically generate the process plan must be identified. The output of the system (the process plan) is information that uniquely describes the production and assembly of the product. In addition, it may include a graphical design representation when appropriate to convey process information.

### **8.3 Features of the Prototype Window Design and Process Planning System**

This section describes the features and functionality of the prototype window design and automated process planning system. Marvin Windows' software currently provides some of the design functionality of the proposed software, albeit not in an integrated system. For example, designers can specify windows from a library of window types and available

options in both the Marvin Design System and the Marvin Quote System. Both systems also perform high-level design validation (verification of selected options) with rules-based technology. However, with the exception of the generation of a bill of materials, process planning is not handled by the systems.

It is possible to design at multiple levels of abstraction. Design at a very low level would require specification of low level features and functionality. While providing this capability allows the designer a high degree of flexibility, it may be more appropriate in some cases to design at a higher level of abstraction. High level design allows the designer to specify high level needs or requirements. Designing at high levels of abstraction increases design productivity and improves ease of use of the design system. However, flexibility is reduced to some extent due to the fact that the system “makes certain choices” for the designer based on a predefined algorithm.

Window design could potentially be based on high level analysis of customer needs. For example, high level needs analysis in window design would likely include choosing options such as the desired level of energy efficiency, the region of the country where the window will be installed, and the direction (north, south, east, or west) that the window will face. The system would then choose the optimum design (number and type of glazings, glass coatings, fill gas, etc.) to satisfy these needs. The system selects options based on the assumptions and design rules contained in the model). Such a high level design system would facilitate design by non-technical people by allowing them to automatically specify technical options by answering non-technical questions. Again, the characteristics of the target users of the system should be considered.

Choosing the appropriate level of design abstraction is slightly beyond the scope of this thesis. However, it is mentioned here because the design of the CIM system (specifically the object model and the interface) requires such a choice. The prototype system described below is based on the same level of design abstraction as the systems used by Marvin Windows, since the target users are the same.

### **8.3.1 Design with Parts**

The prototype window design system is based on a predefined kit of parts that are instantiated as needed. The system allows these parts to be combined in valid combinations (assemblies). The configured assembly is then stored in a design database. In some cases, it is most appropriate to allow the graphical editing of a part or a part's shop drawing. The requirements for graphical interfaces have been presented above. Graphical placement and editing of predefined objects are both common functions in CAD systems. CAD integration has not been developed for this prototype system due to ease of implementation issues. The system focuses on the implementation of the parameters and manufacturing constraints for the predefined kit of parts.

### **8.3.2 New Part Creation**

The object oriented representation helps in new part definition because it allows parts to be defined as subclasses of existing classes. Thus, much of the behavior and most interactions are unchanged. However, the creation of new parts is still somewhat complex. It is acceptable (and preferable) for new classes of parts and new classes of assemblies to be defined outside of the design/process planning system.

There are several reasons for an off-line maintenance strategy.

- First, model changes require a substantial understanding of the design validation issues and the production process constraints governing the entire class hierarchy. For example, if the system utilized a rules-based configurator, the rules would need to be defined for any and all objects that interact with the new part. For a constraint-based configuration solution, the constraints on the new class must be specified. The required manufacturing process information and the parametric process plan must also be defined for new part classes. This information must be defined in terms of the resources required and available for production. For some new classes of parts, parametrically defined geometric representations must also be created and bound to the object. It is unrealistic and undesirable to expect all users to have the necessary level of knowledge and expertise to fully define a new class of part or assembly, particularly with regard to the process constraints (which may represent sensitive internal information regarding competencies and capabilities).
- Second, changes to the class hierarchy are relatively infrequent — a well defined model will provide substantial design flexibility through instantiations of existing classes of parts.
- Third, the interface may require changes to accommodate a new part class.

A separate interface to the class hierarchy should be developed for system maintenance tasks such as new part/assembly creation and/or editing of existing classes of parts/assemblies.

### **8.3.3 Design Validation**

Design and validation can be completely integrated. As the designer chooses options, other invalid options are eliminated from the valid choices. The system determines validity by checking the current state against the configuration model. Validation can occur in real-time when model complexity and processor speed are such that system performance is satisfactory.

In the relatively simple prototype window design system, configuration checking is embedded in the interface. While this method is satisfactory for the demonstration, an object oriented constraint based configurator is preferable for real world systems. However, since this thesis focuses on process planning, and since commercially available

configuration solutions exist, a simplified configuration logic is acceptable for the prototype system.

Once the designer has completely specified a valid window, the system will automatically generate the required production information for the window and for all of its subassemblies and parts. The next section describes a hypothetical window manufacturing factory and identifies the information requirements for each step in the process.

#### ***8.4 The Hypothetical Window Manufacturing Factory***

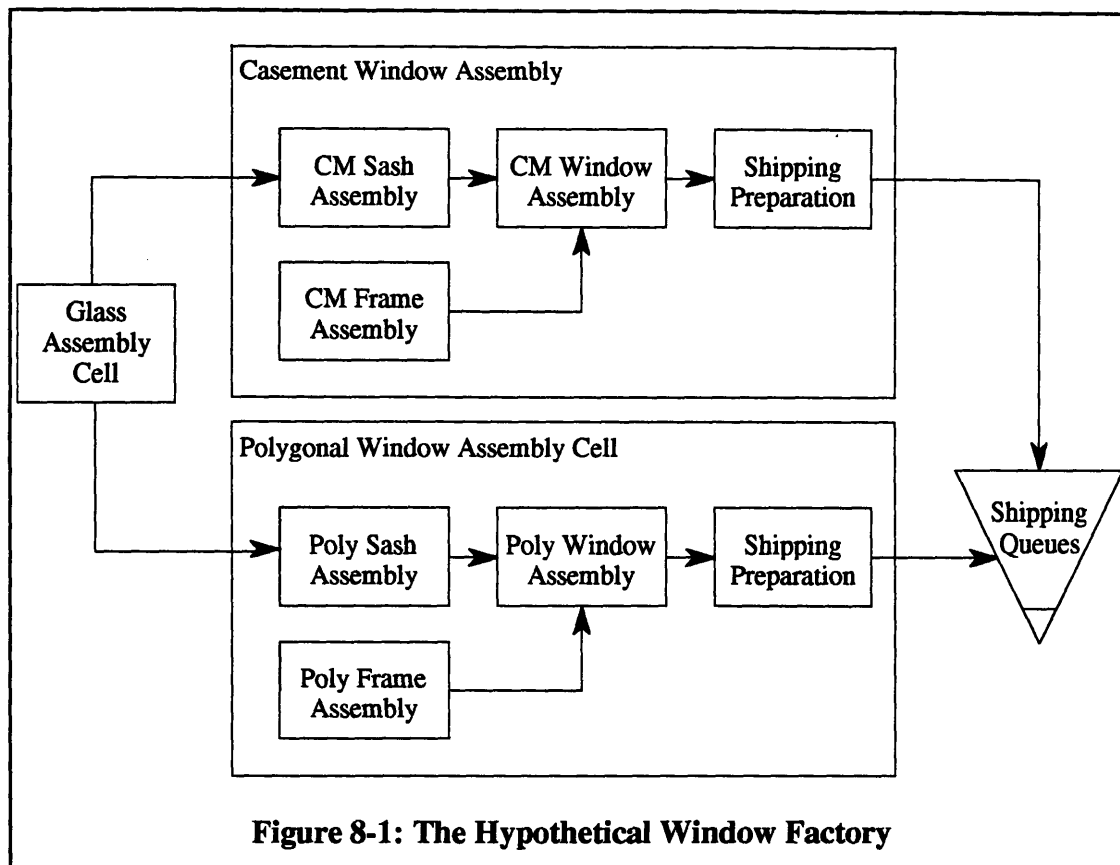
The class hierarchy that represents the kit of parts contains the rules and procedures for manufacturing and assembling the product. Since these rules include assumptions about the available production resources, they must be based on production at a specific factory. Therefore, this section describes a hypothetical window manufacturing factory, including: the production resources, the process flows, and the information requirements at each step of the production process. Section 8.5 then presents the class hierarchy representing the kit of parts.

In the following representation, the hypothetical window manufacturing factory utilizes a cellular manufacturing approach to assemble windows from a kit of parts. It consists of work cells for fabrication of each of the primary assemblies and a routing system consisting of AGV's (automated guided vehicles). Of course, it is based heavily on the case study performed at Marvin Windows, as well as the published resources described elsewhere in the thesis. A moderate level of automation is described, but suggestions for higher levels of automation that could be implemented in the future are provided when applicable.

The hypothetical window factory contains three types of work cells: a cell that fabricates glass subassemblies; an assembly cell for casement windows; and, an assembly cell for polygonal windows. The material flows and layout of the hypothetical factory are shown in Figure 8-1.

The layout of the hypothetical window factory is consistent with the principles of cellular manufacturing. It is assumed that there are machines and processes unique to each of the part families (casement windows, polygonal windows, glass subassemblies). This is in fact the case with most off-site production systems. As described in Chapter Four, special purpose machines are often used which perform functions for a specified range of products. For example, floor trusses and roof trusses are considered different part families and are assembled with different equipment. If the machines used in production could be used for all types of windows, then cellular specialization by product type would not be appropriate.

Glass subassemblies are fabricated and routed to the sash assembly process in the appropriate workcell (casement or polygonal). Assembled sashes and frames proceed to the final window assembly process, where workers insert the sash and apply other window treatments. Workers then apply protective wraps to the assembled windows and route



them to one of several shipping queues. Each shipping queue corresponds to a particular truckload of windows.

Component parts production and inventory are not shown in the diagram. It is assumed that stock sizes of components in the kit of parts are manufactured in a different workcell or workcells and are inventoried in the cells that utilize them. For example, it is assumed that casement frame parts are inventoried near the frame assembly process in the casement window assembly workcell. This is acceptable since there will be some sizes of parts that are required often. It is not the objective of flexible manufacturing systems to eliminate the production of “standard products,” but rather to make non-standard products equally cost effective.

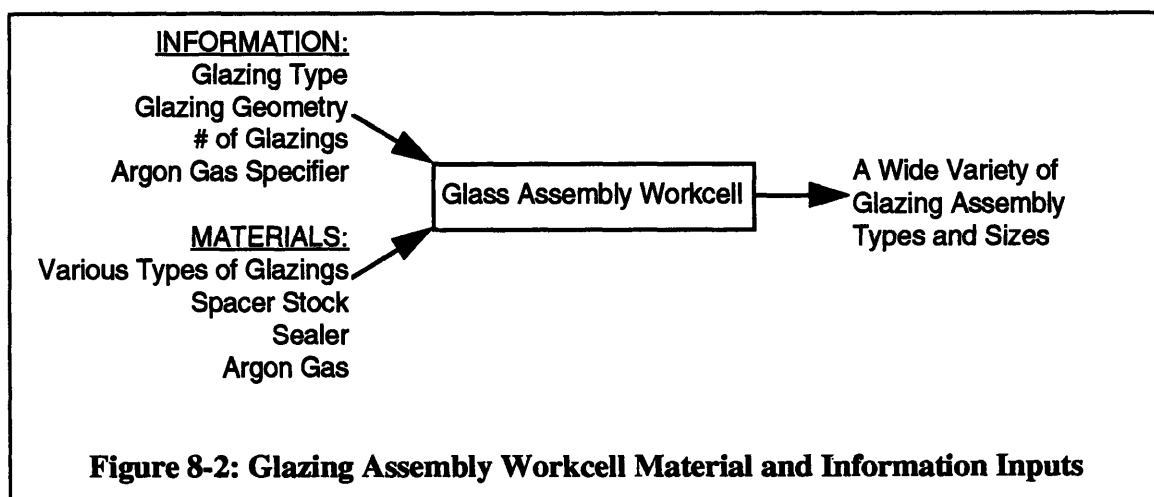
Note that in a real factory, there may be multiple identical cells for some processes. The required processing times, the expected demand, and the availability of resources determine the appropriate number of cells of each type. Real-time finite capacity scheduling can optimize a routing between identical cells. Such algorithms consider current workloads, current resource allocations, machine capacities, and unplanned events such as machine breakdowns.

Production processes in each of the work cells are described in more detail below. Specifically, the material and information flows are described and the information requirements at each step are identified.

### 8.4.1 Glass Assembly

The glass assembly cell is responsible for fabricating and assembling standard and custom shaped glass parts and subassemblies. The workcell is modeled after the Special Glass department at Marvin Windows. It is assumed that there are two types of production resources utilized for cutting glass: a CNC glass cutting machine, and a manual process. It is assumed that certain types of cuts cannot be made on the CNC machine. For this hypothetical case, it is assumed that glazings that are thicker than 3/16 inch must be cut manually. Also, it is assumed that angles smaller than fifteen degrees must be cut manually for all glazing thickness'. Due to handling conditions, a final constraint is that the largest and smallest sizes (bounding box dimensions) for glazings cut by the CNC machine are ninety-six and four inches.

In the glass assembly cell, large sheets of glass are inventoried in various thickness' and styles (standard, tempered, and low-E coated) and are cut as needed. For the CNC production resource, an entire sheet is optimized and cut in a batch. The information required for processing each subassembly is the glazing type, the glazing thickness, and the geometry of the assembly. The high level process planner must structure this information in a format for use by the CNC machine controller (a post-processor and low level process planner). The post-processor minimizes material waste by optimizing the layout of the various pieces on the large glass sheets. The low level process planner then controls the machine motions to perform the required cuts. Workers reorder and sort the pieces for routing by window type as they remove them from the machine. Workers receive sorting information from a numbered graphical representation of the entire sheet that is displayed on a computer screen above the machine (See Section 7.11 for a more detailed description of this process).



**Figure 8-2: Glazing Assembly Workcell Material and Information Inputs**

An automated machine cuts the spacers for both manual and CNC-cut glazings. No production constraints are assumed. The machine coordinates with the cell controller and automatically receives geometry and order sequencing data. The spacers and glazings are sequenced to arrive at the assembly process simultaneously. A worker assembles the pieces manually. No extra assembly equipment is necessary. A worker then seals the unit



by guiding a sealant dispensing nozzle around the perimeter of the assembly. The only information required for assembly, in addition to the information automatically received from the glass cutting cell, is whether or not argon gas is required. When the glass assembly is complete, a worker applies a sticker to it that contains a bar-code and an argon gas identifier. The bar-code identifies the assembly in other workcells. A worker then injects the window with argon gas, if required, and routes the unit to the appropriate window assembly workcell.

The design system must be capable of specifying the information shown in Figure 8-2. In addition, the design system must be aware of the constraints imposed by the production system.

In pseudo-code, the process plan for any glazing assembly is as follows:

Determine production resource: Based on process constraints

Cut glazings: If glazing production resource = CNC, enter geometry into CNC cut list by glazing type, else generate shop drawing and specification and send to manual resource.

Assemble unit: No process information required

Fill gas: If argon gas = True, fill with argon gas.

Route to sash assembly cell: Destination = "Window Type" sash workstation

There are two ways to determine what production resource can be used for the glazing. In a rules-based approach, the following expression would be evaluated:

Determine Production Resource: if  $\text{MinBoundingBoxDimension} < 4''$  or  $\text{MaxBoundingBoxDimension} > 96''$  or  $\text{glazing thickness} > 3/16''$  or  $\text{angle} < 15$  degrees, then  $\text{glazing production resource} = \text{manual}$ , else  $\text{glazing production resource} = \text{CNC}$

An object oriented structure can also be used. It is appropriate for cases where there are several different production resources or where production resources change frequently. The object oriented approach is implemented in the prototype system. In the object oriented approach, the individual attributes or decision variables are modeled. For example, the attributes provided by different glazing production resources can be defined as:  $\text{MinAngle}$ ,  $\text{MaxGlazingThickness}$ ,  $\text{MinBoundingBoxDimension}$ , and  $\text{MaxBoundingBoxDimension}$ . With this approach, the following expression would be evaluated to determine an acceptable production resource:

Loop over all instances of glazing production resources...

If  $\text{resource}(i).\text{MaxGlazingThickness} > \text{glazing.Thickness}$  and  $\text{resource}(i).\text{MinBoundingBoxDimension} < \text{glazing.MinBoundingBoxDimension}$  and  $\text{resource}(i).\text{MaxBoundingBoxDimension} > \text{glazing.MaxBoundingBoxDimension}$  and  $\text{resource}(i).\text{SmallestAngle} < \text{glazing.SmallestAngle}$ , then  $\text{glazing production resource} = \text{current}$ , stop, else try next resource.

Failure message = "No capable resource is available."

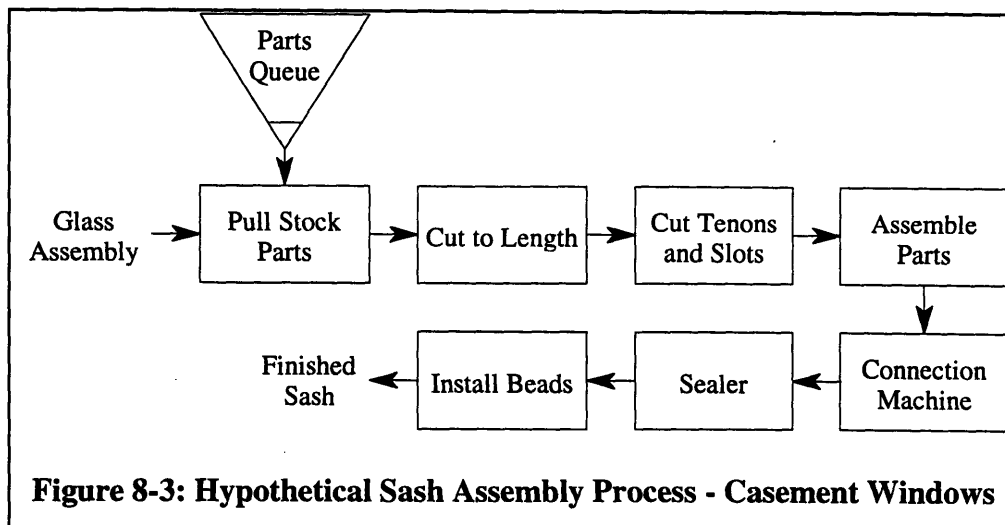
The advantage of the object oriented structure is that this model of the process does not have to change if a production resource changes (the attributes of the new resource must simply be defined). Also, the expression is fairly simple. The size of the expression is based on the number of decision variables, not the number of resources. It is easy to see that the rules based approach requires a very complicated set of if-then rules if there are large number of production resources with different capabilities, while the object oriented approach is much more efficient.

Note also that the above algorithm stops when an “acceptable” resource is found. It may not be the optimal resource. Local optimization can occur when several conditions are met. First, the system would have to evaluate all production resources and keep track of the list of acceptable solutions. This may not be preferable due to performance issues. Second, an optimizing algorithm must be devised (there must be some way to compare the acceptable solutions). For example, load balancing between production resources is one way to optimize throughput. Third, the validity of the list of acceptable solutions and the locally optimal solution must not be altered by subsequent choices — i.e., the local behavior must be independent of the non-local conditions. For example, the optimal load-balanced solution can’t depend on to what resource the part will be routed next (which has not been determined yet since there may be several acceptable resources - which will be optimized locally... and so on). The locally optimal solution must be truly local. Global optimization of constraint-based solutions is an intractable (NP-Hard) problem.

#### **8.4.2 Sash Assembly - Casement Windows**

Sash assembly is a multi-step process, as shown in Figure 8-3. Under the envisioned flexible manufacturing system, a glass subassembly enters the workcell and a worker scans its bar-code. The cell controller automatically queries the manufacturing database to identify the sash. The correct sizes of the stock parts appear on the computer screen for the parts puller. In a fully automated factory, a robot could automatically retrieve the parts from the bins of stock-sized parts. Each piece must then be cut to length. The computer controlled saw automatically sets the blade at the correct position, ensuring a precise cut. Likewise, a computer controlled slot and tenon machine automatically prepares the ends of the rails and stiles for assembly. The worker then assembles the parts and places the assembly in the sash connection machine. The connection machine is a special purpose machine that automatically squares, fixtures, and connects the sash at the four corners.

Operations in this workcell are constrained by the minimum and maximum sizes that can be handled by the connection machine. Workers must manually connect smaller and larger sash (the special purpose machine is not designed to accommodate these). It is assumed that the smallest and largest dimensions that can be handled by the connection machine are sixteen and seventy-two inches, respectively. Once connected, the sash will proceed along an assembly line where workers perform certain finishing operations. These include: installation of the glazing sub-assembly, application of a sealer, and installation of a rubber bead and a cap bead.



Thus, the information that must be generated for casement sash assembly includes the finished sizes of each of the component parts and the sizes of the stock parts to be used to fabricate the parts, which are based on the sizes available in inventory. As in glass cutting, material optimization routines could be utilized by the cell controller to minimize waste in the cutting operation. Such algorithms would be constrained by the ability of the work cell to reorder cut parts prior to assembly.

The pseudo-coded process plan for any casement window sash assembly is as follows:

- Select Stock Size Components: Generate list of stock size components
- Cut sash components to length: Generate list of cut sizes
- Determine connection resource: Based on sash geometry
- Assemble sash frame: If connection resource = CNC then route parts to machine, else route parts to manual assembler
- Insert glass assembly and glazing cap: No information required
- Route to final assembly: Destination = Casement window final assembly

### 8.4.3 Sash Assembly - Polygonal Windows

Polygonal sash assembly proceeds identically to casement sash assembly, with the exception that workers always connect the parts manually using powered hand tools (there is no special purpose machine for polygonal sash assembly). Because of the complex shapes, workers require more information, including the stock parts' rough and finished overall lengths and the required cut angles. Workers also require layout information to assemble the sash parts.

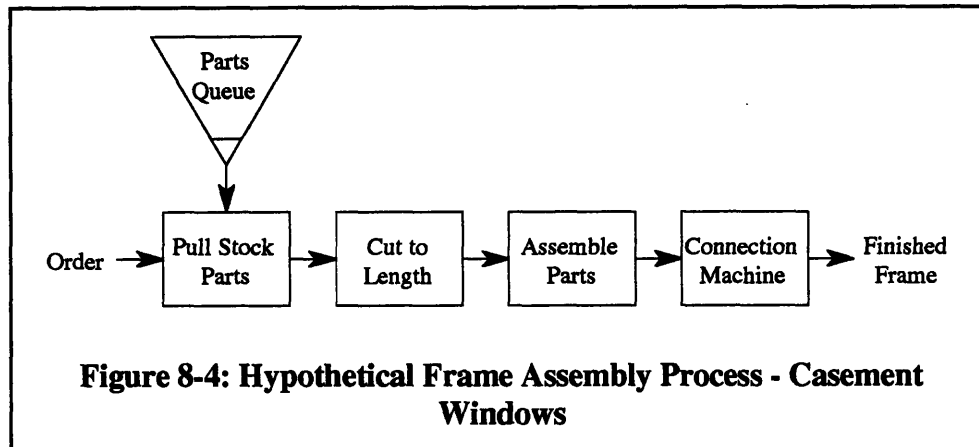
The pseudo-coded process plan for any polygonal window sash assembly is as follows:

- Select Stock Size Components: Generate list of stock size components
- Cut sash components to length: Generate cut list containing sizes and angles and send to manual resource.
- Assemble sash frame: Generate shop drawing for assembler
- Insert glass assembly and glazing cap: No information required

Route to final assembly: Destination = Polygonal window final assembly

#### 8.4.4 Frame Assembly - Casement Windows

The casement frame assembly process is depicted in Figure 8-4. Under the envisioned flexible manufacturing system, production of a window frame is triggered when its glass subassembly enters sash production (so the operations are synchronized). The cell controller automatically identifies the glass subassembly, queries the manufacturing database to identify the frame, and retrieves the frame specification.



The correct stock parts sizes appear on the computer screen for the parts puller. In a fully automated factory, a robot could automatically retrieve the parts from the bins of stock-sized parts. Each piece must then be cut to length. The computer controlled saw automatically sets the blade at the correct position, ensuring a precise cut. Likewise, a computer controlled slot and tenon machine automatically prepares the ends of the header, sill, and jambs for assembly.

The worker then assembles the parts and places the assembly in the frame connection machine. The connection machine is a special purpose machine that automatically squares, fixtures, and connects the frame at the four corners. Operations in this workcell are constrained by the minimum and maximum sizes that can be handled by the connection machine. Larger and smaller frames must be connected manually. It is assumed that the smallest and largest dimensions that can be handled by the frame connection machine are eighteen and ninety-six inches, respectively.

Thus, the information that must be generated for casement frame assembly includes the stock and cut sizes of each of the component parts.

The pseudo-coded process plan for any casement window frame assembly is as follows:

- Select Stock Size Components: Generate list of stock size components
- Cut frame components to length: Generate list of cut sizes.
- Determine connection resource: Based on frame geometry

Assemble frame: If connection resource = machine then route to machine, else  
route to manual assembler  
Route to final assembly: Destination = Casement window final assembly

#### **8.4.5 Frame Assembly - Polygonal Windows**

Polygonal frame assembly proceeds identically to casement frame assembly, with the exception that all connections are performed manually with powered hand tools. Because of the complex shapes, more information must be transferred to workers, including the stock parts' rough and finished overall lengths and the required cut angles. Also, layout information is required to assemble the frame parts.

The pseudo-coded process plan for any polygonal window frame assembly is as follows:

Select Stock Size Components: Generate list of stock size components

Cut frame components to length: Generate cut list containing sizes and required angles.

Assemble frame: Generate shop drawing for assembler.

Insert glass sub-assembly and glazing cap: No information required

Route to final assembly: Destination = Polygonal window final assembly

#### **8.4.6 Final Window Assembly**

In the hypothetical final assembly process, a window is assembled from a frame and a sash. The parts are assembled manually, and the process requires no additional information. However, in a real factory, window options such as jamb extensions and casings would also be installed at this point. These operations are typically performed manually with powered hand tools. Thus, a production order would need to be generated. The required information could easily be generated from window object data stored in the database. It could be printed or could simply appear on a computer screen in the workcell. Shop drawings could be generated as needed.

#### **8.4.7 Shipping Preparation**

In the shipping preparation cell, cardboard, plastic and wood packaging is attached to all assembled windows to protect them during transport. The operation is performed manually with powered hand tools. No information is required for the process.

#### **8.4.8 Shipping Queue**

The bar-code on each window is read as it enters the queue. Near to the shipping time, a worker can generate an exception report to identify and track windows that have not been completed. Once all the windows for a specific truckload have reached the queue, they can be quickly loaded into the truck. As was noted in Chapter Seven, knowing that all the windows are actually in the shipping queue doubles the productivity of the workers loading the truck. No process planning information is required by the shipping queue.

## 8.5 The Hypothetical Kit of Parts

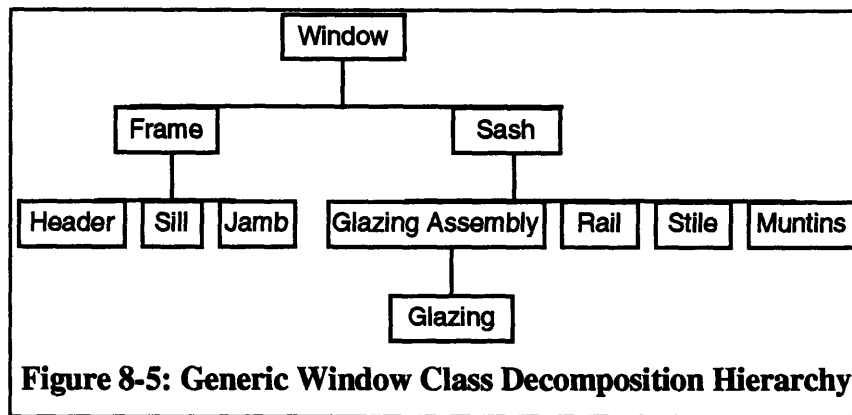
The kit of parts for the prototype system is composed of component parts for fabricating continuously variable sizes of casement windows and continuously variable sizes and shapes of polygonal windows. Casement windows, which have a standard rectangular shape, represent the “standard product line” problem. Polygonal windows demonstrate applicability to more complicated geometry. The kit of parts includes frame parts, sash parts, and parts for glass subassemblies.

This section describes the class decomposition hierarchy for the kit of parts. The class decomposition hierarchy represents the relationships between the assemblies and components. In other words, it shows which objects are contained within (are part of) other objects.

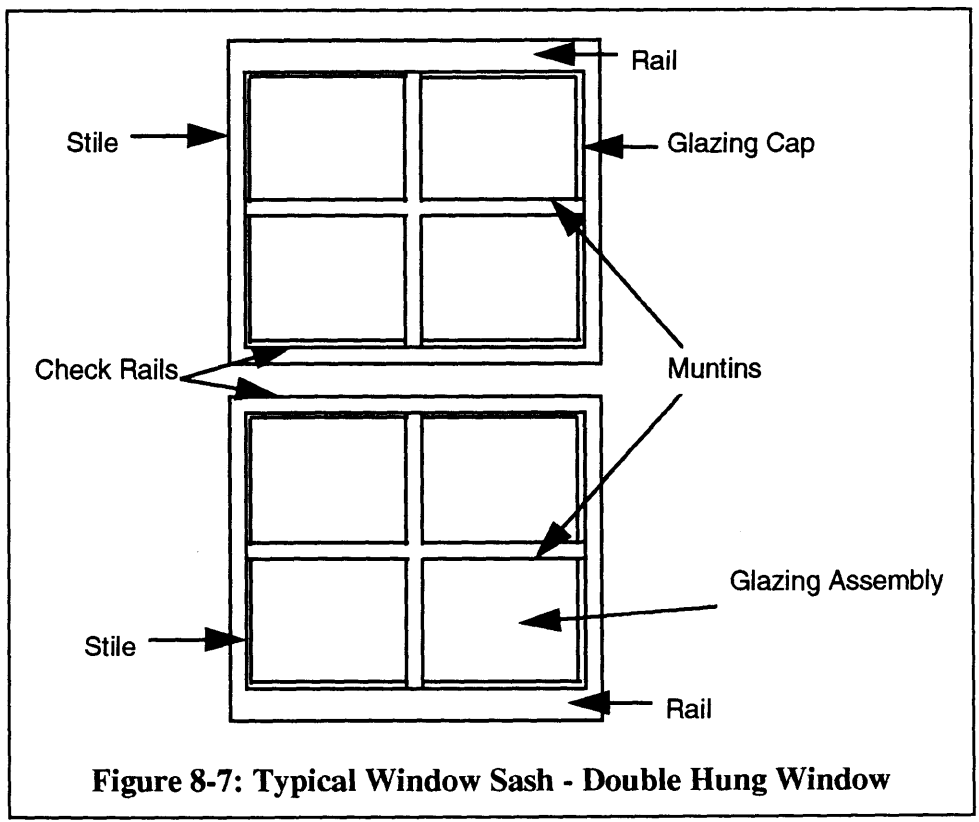
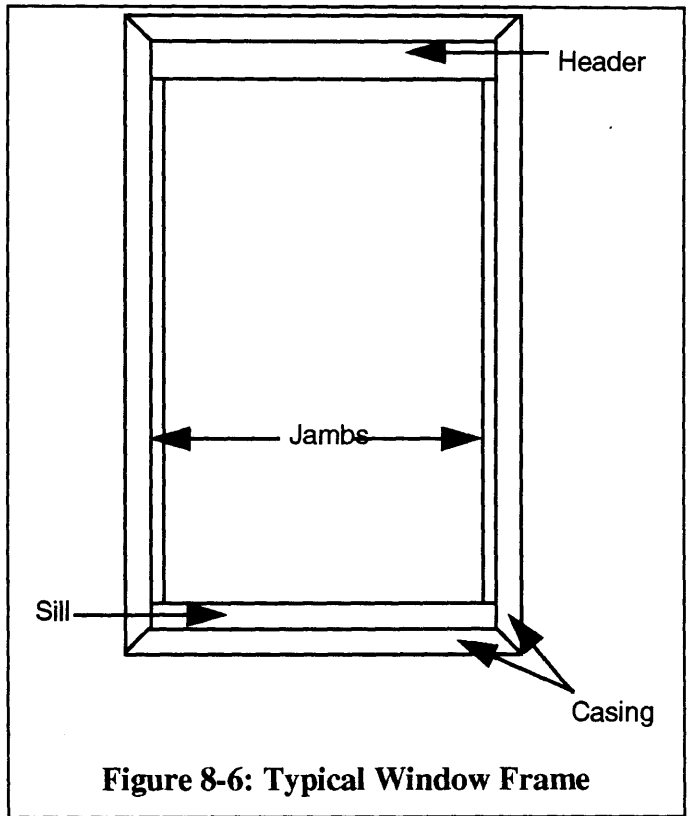
Section 8.6 will describe the class hierarchy, which shows the specialization of classes of objects. For example, a casement window is a special type, or subclass, of a window class. In an object oriented implementation, a subclass inherits the attributes and functions of the parent class, and can override and/or add to the functionality.

### 8.5.1 Generic Window Assembly - Class Decomposition

Window assemblies have the general structure shown in Figure 8-5. They contain a frame subassembly and one or more sash subassemblies (two sash in the case of double hung windows, which are not modeled in the prototype system).



Frame subassemblies are composed of frame parts, which are classified as headers, sills, and jams. As shown in Figure 8-6, headers and sills are the top and bottom horizontal frame members, respectively. A jamb is a vertical frame member. As shown in Figure 8-6, casing is any decorative millwork or trim which surrounds the frame members. Casing is usually installed on both the inside and outside of the window frame. For simplicity, casing was not modeled in the system.

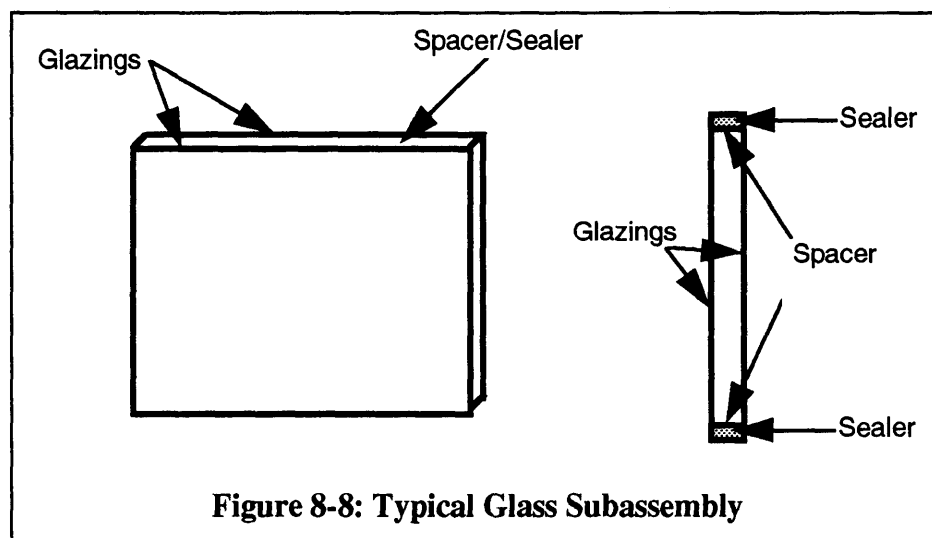


Sash subassemblies are composed of a glass subassembly and sash parts, which include rails, stiles, muntins, and glazing caps. As shown in Figure 8-7, rails and stiles are the horizontal and vertical sash members, respectively. For a double hung window, which is represented in the Figure, the center rails (the bottom rail of the top sash and the top rail of the bottom sash) are called “check rails.” Muntins are the decorative “grills” on the glazing assembly. The glazing cap is the small piece of trim which secures the glazing assembly in the sash.

As shown in Figure 8-5 and Figure 8-8, glazing assemblies consist of the following parts:

- glazing objects, the actual glass pieces;
- spacers, aluminum parts found in double and triple-glazed window;
- sealer, a polybutylene bead that seals the subassembly;
- argon gas, a thermally superior filler gas for double and triple-glazed windows.

As shown in Figure 8-8, the glazings are separated by the spacers. Sealer surrounds the spacer and provides a leak-proof assembly. Argon gas, when present, fills the space



**Figure 8-8: Typical Glass Subassembly**

between the glazings. In the prototype system, only glazings are implemented as separate part objects. Sealer is a non-varying step in fabrication of the assembly, so process modeling is unnecessary. Likewise, argon gas is satisfactorily implemented as an attribute of the assembly. Spacer fabrication is assumed to be generated by the cell controller (post-processor), as is the case in the Marvin Windows factory, based on the geometry of the glazing assembly.

Glazing assembly parts are independent of the window type. The interactions between the sash and glazing assembly can be defined strictly by the geometry of the glazing assembly.

Note that other window-level features (and parts) are possible, such as mulled units, jamb extensions, sill horns, weather-stripping, screens, hardware, and others. Although they are not modeled here for simplicity, they would be implemented in the same manner.



Specific subclasses of windows follow the general structure described above. However, as described below, they are composed of specialized variations of the constituent parts.

### 8.5.2 Casement Window Assembly - Class Decomposition

As shown in Figure 8-9, a casement window object is composed of one casement frame object and one casement sash object.

The casement frame parts are the specific instances of frame parts that uniquely define a casement window frame. A casement frame consists of:

- a casement header, the top horizontal frame member for the casement window;
- a casement sill, the bottom horizontal frame member for the casement window;
- a left casement jamb, the left vertical frame member for the casement window;
- a right casement jamb, the right vertical frame member for the casement window.

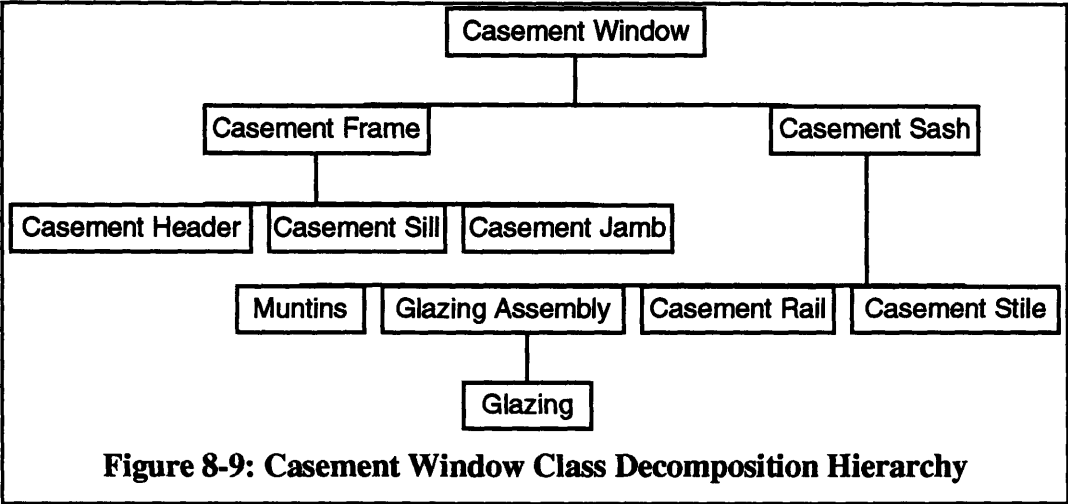


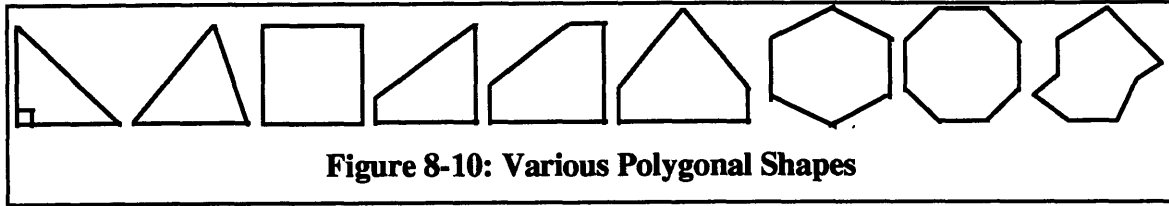
Figure 8-9: Casement Window Class Decomposition Hierarchy

Like casement frame components, the casement sash components are specialized instances of sash components. A casement window sash consists of:

- a glazing assembly;
- two casement rails, the horizontal sash members for a wood casement window;
- two casement stiles, the vertical sash members for a wood casement window;
- muntins.

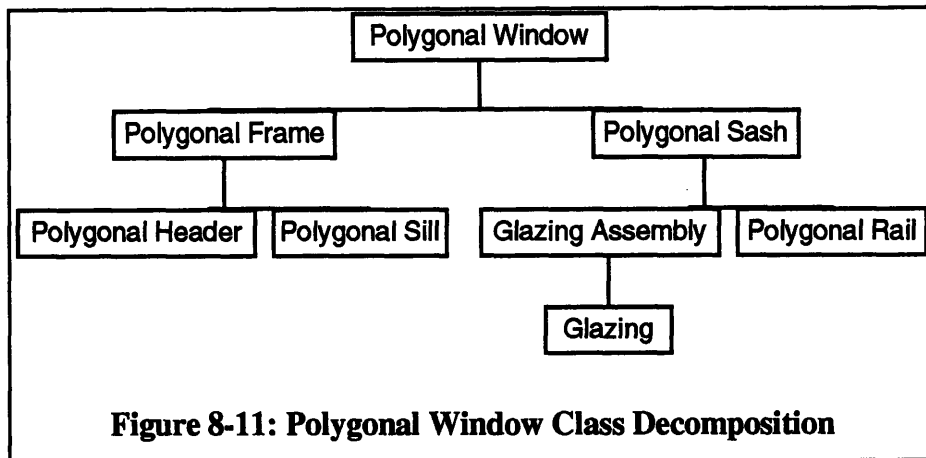
### 8.5.3 Polygonal Window Assembly - Class Decomposition

Polygonal windows include all angular-shaped windows. As shown in Figure 8-10, polygonal windows are available in almost unlimited varieties. Some common polygonal shapes can be predefined. The first eight shapes in Figure 8-10 represent predefined shapes. The last one is a custom shaped polygonal window. All polygonal windows share the feature that they are not operable (thus require no hardware) and they are all built from the same set of polygonal window sash and frame parts.



**Figure 8-10: Various Polygonal Shapes**

Polygonal components are specialized instances of component window parts that uniquely define polygonal windows. For example, polygonal frames have no jambs. Because of their unique shapes, polygonal windows utilize the same component (header) for all parts except horizontal (polygonal sill) members. In the hypothetical factory, it is assumed that polygonal frame and sash parts are maintained in stock sizes and are cut as required.



**Figure 8-11: Polygonal Window Class Decomposition**

Now that the hypothetical window factory and the kit of parts have been defined, the next section will present the prototype system.

### ***8.6 A Prototype System for Flexible Computer Aided Process Planning in Window Manufacturing***

This Section presents the implementation of the prototype process planning system. Section 8.6.1 includes screen-shots of the application and describes the functionality that it provides. Section 8.6.2 through Section 8.6.5 detail the class hierarchies, the objects' data (variables), and the objects' methods (procedures). Pertinent sections of the actual code are included in Appendix B.

The system consists of a series of input screens, a set of database tables, and the process planning algorithms. The input screens allow customized windows to be specified by the user. The window definitions are then stored in a relational database. The process planning algorithms read the database, generate process planning information, and send the information to "virtual" production resources. The "virtual" resources are represented in database tables by the information that the corresponding physical production resource requires. Examples of virtual production resources include parts inventory, a CNC glass cutter, a manual casement window assembly operation, and others.

The architecture of the prototype system was chosen to closely resemble one which could be implemented for a real-world system. Sales people, dealers, distributors, architects, and/or customers would likely use a window design and sales order entry system to specify and order windows. The orders would then be stored in a centralized database (the integrated design-manufacturing database mentioned in Section 8.2.1.3). As product orders are received, the process planning system would read the database, generate the process plan, and distribute the information to the respective production resources.

The input screens and process planning algorithms were implemented using Microsoft's Visual Basic. The database was implemented with Microsoft Access. Both are readily available and widely supported and would be inexpensive to use for manufacturers of building products. Visual Basic provides support for classes of objects, although inheritance is not supported. Inheritance would not directly add to the functionality of the planning system, but inheritance would simplify system maintenance. Nevertheless, Visual Basic was chosen for its excellent rapid prototyping capabilities.

### 8.6.1 Program Functionality and Operation

The program contains three distinct segments: a database of designed and specified windows listed by window type; the means for designing and specifying new windows; and, the ability to generate a batch of process plans for all of the windows in the database. The main screen provides a view into the database of designed windows. In addition, it provides pull down menus and buttons for invoking the window specification screens and the process planning system.

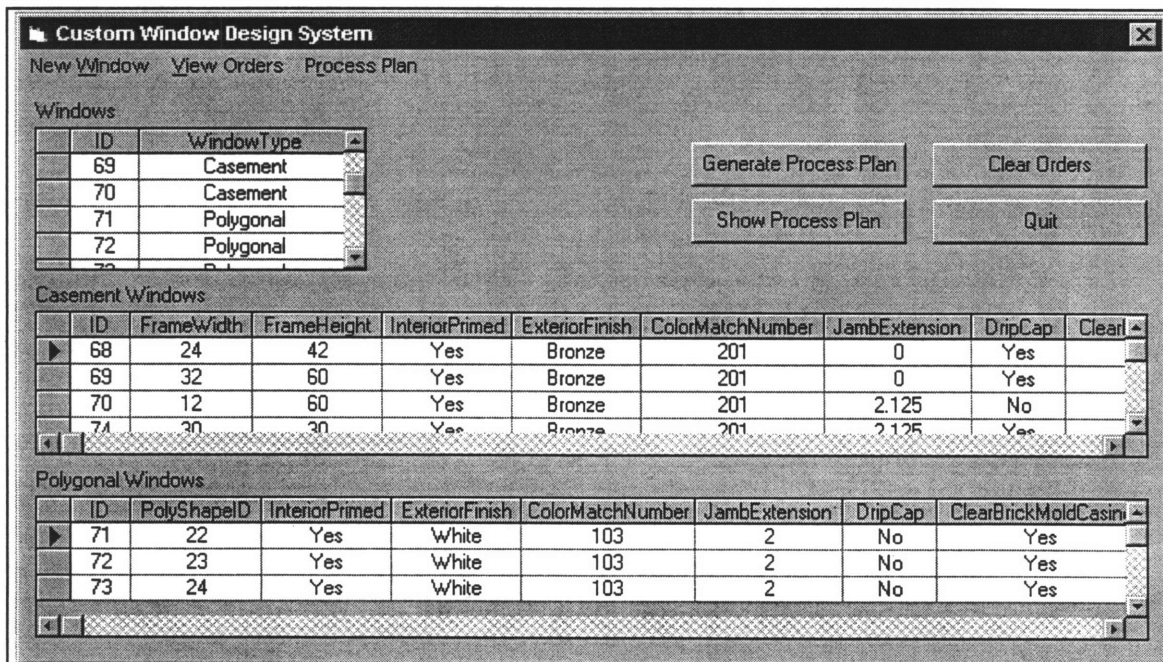


Figure 8-12: Main Screen

### 8.6.1.1 Window Design / Specification

Under the “New Window” menu on the main screen, the designer can select a menu item to add a new casement window or a new polygonal window. Each selection activates a screen containing options specific to each window type. Figure 8-13 and Figure 8-14 show the casement and polygonal specification screens, respectively.

Casement window design requires the specification of the window size, as well as the selection of several frame, sash, and finish options. Window sizes can be specified in terms of the actual frame size, the rough opening size, the masonry opening size, or the glass opening size. Also, width and height need not be specified in the same terms.

Frame options that the designer must specify include the size of the jamb extension, if any, and whether or not the window should have an aluminum drip cap, clear brick mold casing, or a clear sill. Sash options that must be specified include whether or not the window should have a screen or storm panel, as well as the type of muntins, if any. Finish options include the choice of standard and custom exterior colors, and whether or not the inside of the window should be primed.

**Casement Window Options**

**Window Size**

Width: 24.0 Inches  
Height: 42.0 Inches

Frame Size: [Dropdown]  
Rough Opening: [Dropdown]

**Frame Options**

Jamb Extension: 2.25 Inches

Aluminum Drip Cap  
 Clear Brick Mold Casing  
 Clear Sill

**Sash Options**

Rectangular Removable Grills [Dropdown]

Screen  Storm Panel

**Finish Options**

Interior Primed

Exterior Finish: Bronze [Dropdown]

Ext. Color Match #: 201 [Dropdown]

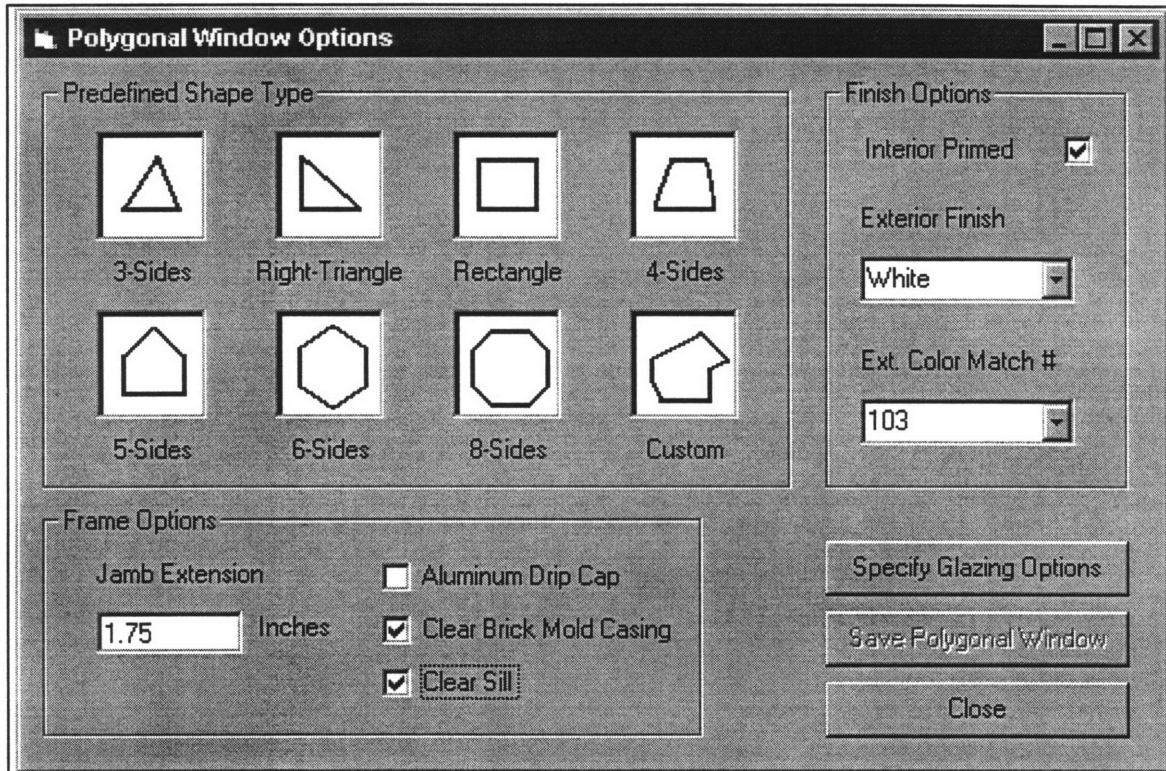
Specify Glazing Options

Save Casement

Close

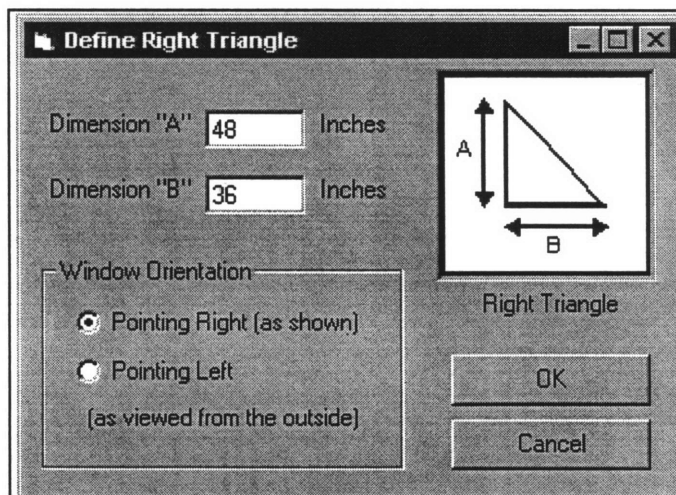
**Figure 8-13: Casement Window Specification**

As shown in Figure 8-14, many of the same choices must be made for polygonal windows as for casement windows, with the exception of sash options. Clearly, the primary difference is the specification of window geometry. The designer can choose one of several predefined polygonal shapes or may specify a completely custom polygonal shape.



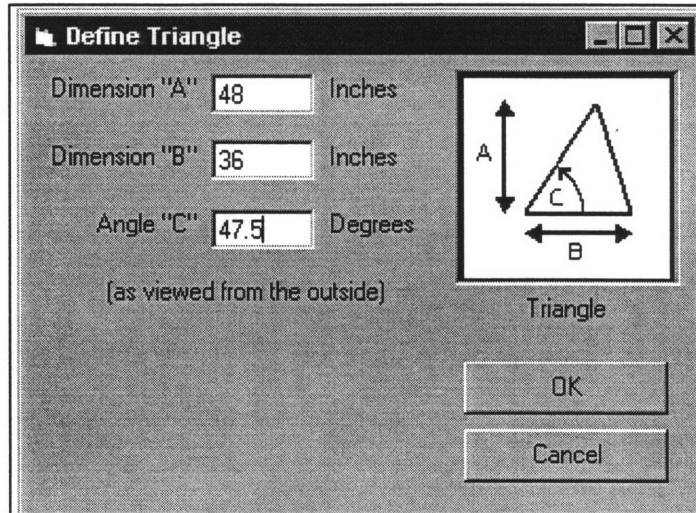
**Figure 8-14: Polygonal Window Specification**

Double clicking on any of the predefined shapes will activate a dialog box within which the geometry can be easily defined. Figure 8-15 shows a dialog box for a right triangle, while Figure 8-16 and Figure 8-17 show the corresponding dialog boxes for a generic triangle and a completely custom shape.

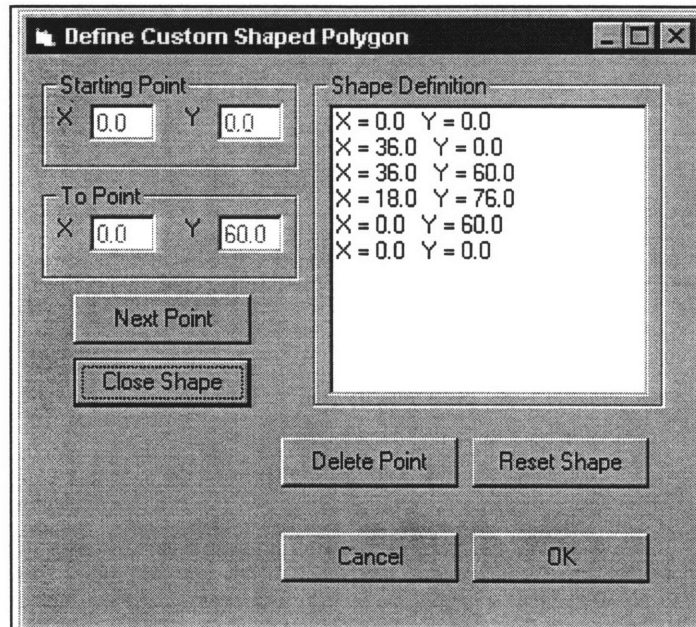


**Figure 8-15: Right Triangle Specification**





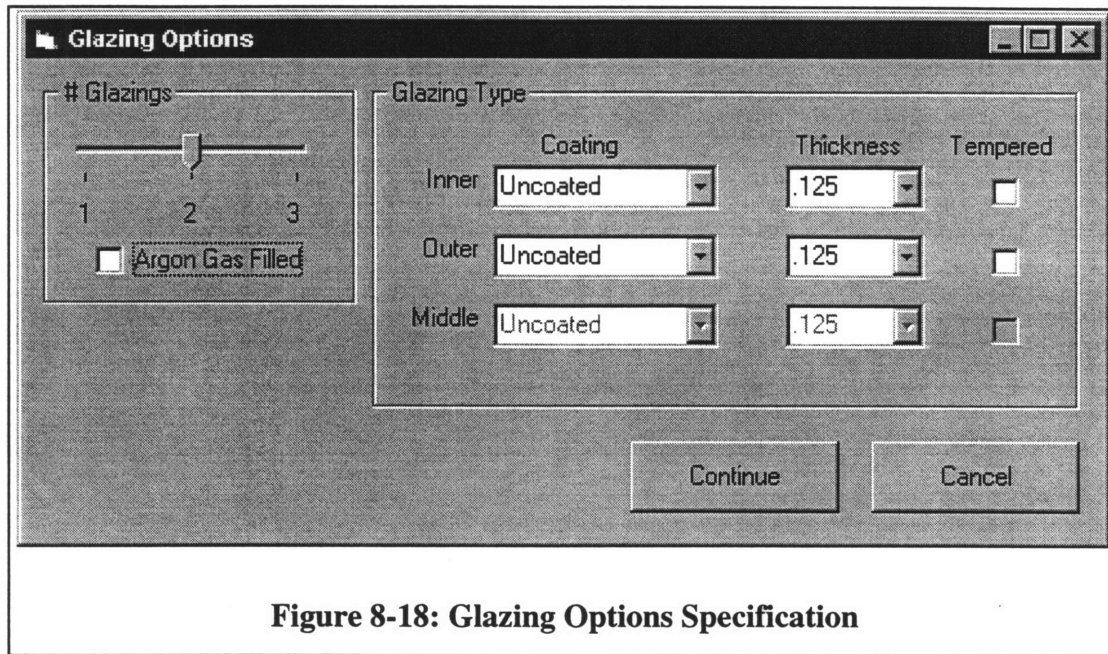
**Figure 8-16: Triangle Specification**



**Figure 8-17: Custom Polygon Specification**

In addition to the above specifications, the designer must also specify the window's glazing options. Both polygonal and casement windows utilize the same dialog box, which is shown in Figure 8-18, for selecting glazing options

Glazing specification requires a choice of the number of glazings. For double and triple glazed assemblies, argon gas can be selected. Finally, the type of each glazing must be specified in terms of the glass thickness, whether or not it should be tempered, and the desired energy efficient coating, if any.



**Figure 8-18: Glazing Options Specification**

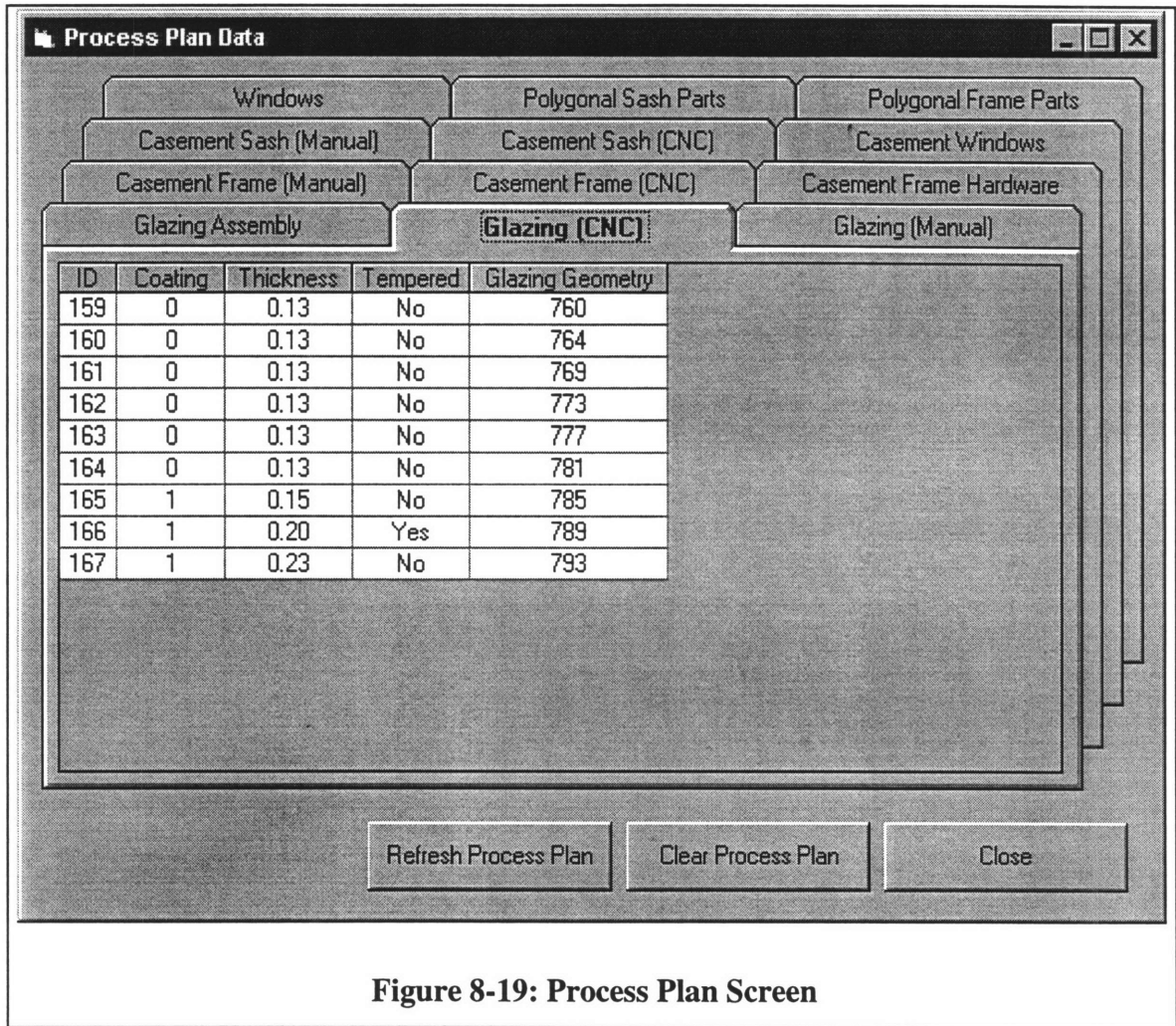
#### 8.6.1.2 Process Plan Generation

The generation of the process plan is transparent to the user. The user simply invokes the process planner and it automatically generates the data required for the production of each part and assembly. This information is stored in the database, which maintains separate tables for each production resource. Figure 8-19 shows the screen used to examine the process plan data. Each tab on the process plan screen presents the data for a single production resource

Based on the window's geometry and type, the process planner identifies a suitable production resource and generates the information required for assembly by that resource. The process planning system then generates the bill of materials (a parts explosion) for the window, including the geometry of each of the component parts and subassemblies.

Next, for each of the component parts the system identifies an available stock size component from which the part can be fabricated. The size and number available in inventory for each stock size component is represented in the database. Therefore, the system insures that the stock size component is available in inventory. As a component is allocated to fabricate a window, the number of parts available in inventory is automatically decremented. If no inventory is available to make the part, the system prompts the user.

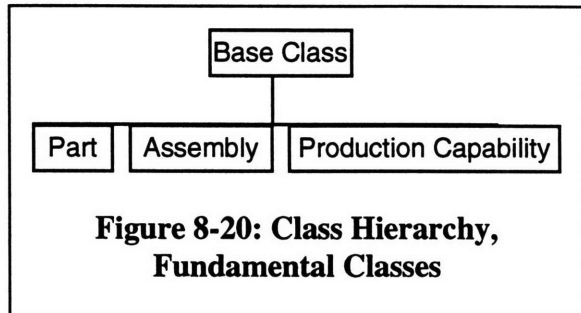
The system prepares and formats the process planning information and sends the individual process plans for each assembly and part to the production resource responsible for carrying out the fabrication and/or assembly of the part. The details of this process are highlighted in the rest of Section 8.6.



### 8.6.2 Fundamental Classes

The object class hierarchy for the prototype system is represented in Figure 8-20, Figure 8-21, and Figure 8-23.

The three fundamental classes in the system are defined in Figure 8-20: Part, Assembly, and Production Capability. The fundamental classes are derived from a base class.\* The Part class is used to define any atomic component of a window. The algorithm and the required data for generating the part's



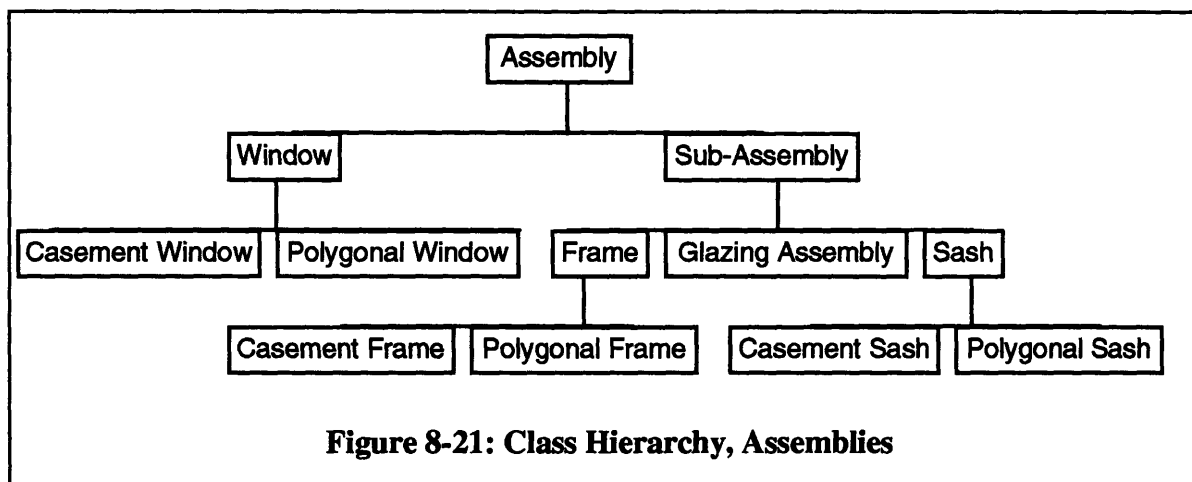
\* Since Visual Basic does not support inheritance, the "deriving" defaulted to: the creation of a derived class which has base functionality copied from the parent class; and, the addition to and/or overriding of base functionality with specialized functionality.



process plan are represented within the Part class. An Assembly class is used to define a group of two or more parts which are associated for production. The Assembly Class contains the process planning information specific to fabrication of the assembly. A Production Capability is used to define any functionality within the production process. The class defines the capabilities and limitations of a process.

### 8.6.3 Assembly Classes

There are two subclasses of Assembly: Window and Subassembly. A window class instantiates and maintains the subassemblies and parts which comprise a window. As an assembly, it also maintains and generates the portion of the process plan specific to the window assembly itself. Likewise, a Subassembly can instantiate and maintain parts and other subassemblies.



The base Window class contains the attributes and functionality shared by all window types. The Casement Window class and the Polygonal Window class are derived from the base Window class, and represent the specialized functionality unique to each class of Window.

Casement windows represent window geometry by the width and height of the frame. However, the user can specify geometry in terms of the rough opening dimensions, the masonry opening dimensions, or the glass opening size. The frame geometry can be computed automatically because the dimensions are parametrically defined for each class of windows. Specifically, the parametric geometry for a Marvin Windows Casemaster casement window was adopted for the demonstration program:

- the masonry opening width is defined to be the frame size plus 3.625 inches;
- the masonry opening height is defined to be the frame size plus 1.8125 inches;
- the rough opening width equals the frame size plus one inch;
- the rough opening height equals the frame size plus one-half inch;
- the glass opening width equals the frame size minus 4.4375
- the glass opening height equals the frame size minus 6.1875

The complexity of Polygonal Windows requires a much more flexible geometric representation. Polygonal Windows maintain a list of the vertices which define the shape of the frame. All component part dimensions are computed from these vertices. Rather than requiring the designer to draw or specify all the vertices of the polygon, the designer is allowed to specify certain types of polygonal shapes in a more convenient (faster) manner. For example, a triangle polygon can be specified by the width, height, and an included angle. The system calculates the vertices automatically and stores the vertices in the object.

In addition to window geometry, each type of window class instantiates and stores appropriate objects to represent its component parts. The “Define” method for each window object creates component objects. For example, the casement window object instantiates a casement frame and a casement sash. The casement frame and casement sash objects in turn create the objects that they contain.

Likewise, the functionality that generates the process plan for each type of window class is implemented within the object hierarchy. The “Make” method of each window class implements the process planning functionality. In addition to the window level plan generation, the window object calls the “Make” methods for each of the window’s component parts and subassemblies, to generate the remaining process plan..

#### *8.6.3.1 Window Class Implementation*

The Window class represents the fundamental attributes shared by all subclasses of window. The following data is stored in the object:

*InteriorPrimed: specified attribute of the window;*  
*ExteriorFinish: specified attribute of the window;*  
*ColorMatchNumber: specified attribute of the window;*  
*JambExtension: specified attribute of the window;*  
*DripCap: specified attribute of the window;*  
*ClearBrickMoldCasing: specified attribute of the window;*  
*ClearSill: specified attribute of the window.*

#### *8.6.3.2 Casement Window Class Implementation*

The Casement Window class represents a casement window and its specified options. The following data is stored in the object:

*itsFrame: a Casement Window Frame subassembly;*  
*itsSash: a Casement Window Sash subassembly;*  
*theFrameWidth: window size (frame width);*  
*theFrameHeight: window size (frame height);*  
*AssemblyResource: the type of assembly resource (CNC or Manual);*  
*MuntinType: specified attribute of the window;*  
*Screen: specified attribute of the window;*  
*StormPanel: specified attribute of the window.*

The Casement Window class contains methods (procedures) for instantiating its component objects as well as for generating the process plan:

*Define: instantiates the Casement Frame and Casement Sash objects (size of sash object is defined parametrically to be the frame size less the frame's offset to the sash channel);*

*Make: generates the process plan for the Casement Window and calls the Make method for the Casement Frame and Casement Sash objects.*

#### 8.6.3.3 Polygonal Window Class Implementation

The Polygonal Window class represents a Polygonal Window and its specified options. The following data is stored in the object:

*itsFrame: a Polygonal Window Frame subassembly;*

*itsSash: a Polygonal Window Sash subassembly;*

*NumPoints: the number of vertices of the polygon;*

*Points: an array of vertices.*

The Polygonal Window class contains methods (procedures) for instantiating its component objects as well as for generating the process plan:

*Define: instantiates the Polygonal Frame and Polygonal Sash objects (geometry of sash object is defined parametrically to be the frame geometry less the frame's offset to the sash channel);*

*Make: generates the process plan for the Polygonal Window and calls the Make method for the Polygonal Frame and Polygonal Sash objects.*

#### 8.6.3.4 Casement Frame Class Implementation

The Casement Frame class represents the Casement Frame subassembly. The Casement Frame class instantiates a Casement Frame Header object, a Casement Frame Sill object, and left and right Casement Frame Jamb objects. The class stores the following data:

*Width: Frame width;*

*Height: Frame height;*

*itsHeader: a CasementFramePart;*

*itsLeftJamb: a CasementFramePart;*

*itsRightJamb: a CasementFramePart;*

*itsSill: a CasementFramePart;*

*AssemblyResource: The type of assembly resource (CNC or Manual) .*

The casement frame class contains methods (procedures) for instantiating its component objects as well as for generating the process plan:

*Choose Assembly Resource: a method which identifies a suitable production resource;*

*Define: instantiates the component parts;*  
*Make: generates the process plan for the Casement Frame.*

#### 8.6.3.5 Polygonal Frame Class Implementation

The Polygonal Frame class represents the Polygonal Frame subassembly. The class stores the following data:

*NumPoints: number of vertices of the polygon;*  
*thePoints: a list of the vertices;*  
*theParts: a list of PolygonalFrameParts.*

The Polygonal Frame class contains methods (procedures) for instantiating its component objects as well as for generating the process plan:

*Define Parts: instantiates the component parts*  
*Make: generates the process plan for the Polygonal Frame*

#### 8.6.3.6 Casement Sash Class Implementation

The Casement Sash class represents the Casement Sash subassembly. The Casement Sash object creates top and bottom Casement Sash Rail objects, left and right Casement Sash Stile objects, and a Glass Subassembly object.

The class stores the following data:

*Width: sash width;*  
*Height: sash height;*  
*itsTopRail: a CasementSashPart;*  
*itsLeftStile: a CasementSashPart;*  
*itsRightStile: a CasementSashPart;*  
*itsBottomRail: a CasementSashPart;*  
*itsGlazingAssembly: a GlazingAssembly;*  
*AssemblyResource: The type of assembly resource (CNC or Manual)*

The Casement Sash class contains methods (procedures) for instantiating its component objects as well as for generating the process plan:

*Choose Assembly Resource: a method which identifies a suitable production resource;*  
*Define: instantiates the component parts;*  
*Make: generates the process plan for the Casement Sash.*

#### 8.6.3.7 Polygonal Sash Class Implementation

The Polygonal Sash class represents the Polygonal Sash subassembly. The class stores the following data:

*NumPoints: number of vertices of the polygon;*  
*thePoints: a list of the vertices;*

*theParts: a list of PolygonalSashParts;*  
*itsGlazingAssembly: a GlazingAssembly.*

The Polygonal Sash class contains methods (procedures) for instantiating its component objects as well as for generating the process plan:

*Define Parts: instantiates the component parts*  
*Make: generates process plan for the Polygonal Sash*

#### 8.6.3.8 Glazing Sub-Assembly Classes

All window types utilize glazing assemblies. There is no distinction between glazing assemblies for casement or polygonal windows from the production standpoint. Therefore, there is no distinction in the implementation of glazing assemblies for different window types.

Generation of the Glazing Assembly process plan is based on the geometry and specifications for the subassembly. Thus, the Glazing Assembly class stores the following data:

*NumGlazings: the number of glazings;*  
*itsInnerGlazing: a Glazing;*  
*itsMiddleGlazing: a Glazing (for triple-glazed windows);*  
*itsOuterGlazing: a Glazing (for double and triple-glazed windows);*  
*ArgonGas: whether or not the assembly should be filled with argon gas (for double and triple-glazed windows);*  
*NumPoints*  
*Points: an array of points describing the geometry*

The Glazing Assembly class contains methods (procedures) for instantiating its component objects as well as for generating the process plan:

*Define Parts: Method which instantiates the component parts*  
*Make: Method which generates the Glazing Assembly process plan*

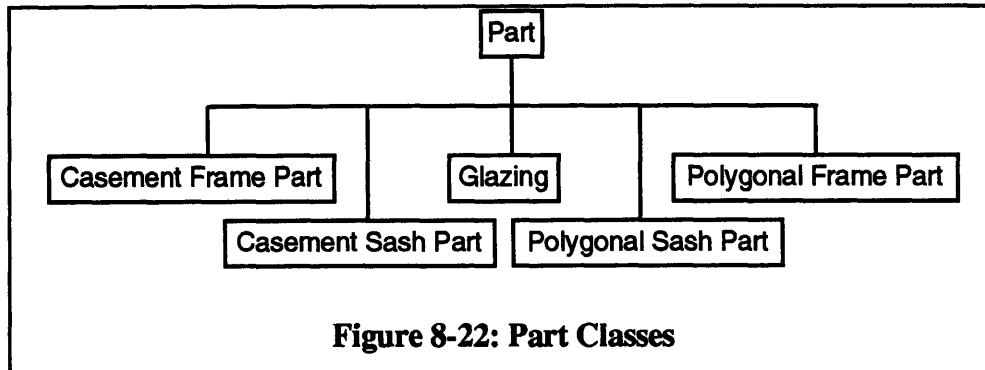
#### 8.6.4 Part Classes

As shown in Figure 8-22, the following parts were implemented in the prototype system: Casement Frame Part, Casement Sash Part, Polygonal Frame Part, Polygonal Sash Part, and Glazing. Each is described below.

##### 8.6.4.1 Casement Frame Part Class Implementation

The casement frame part class stores the length of the casement frame part and the type of frame part (header, sill, or jamb). A method selects a stock size component for the part to be fabricated from based on the required length and the available inventory. The stock size length of the part is transmitted to the casement frame parts puller via the central database.

The required length is transmitted to the casement frame part fabricator, who uses the data to cut the part to the correct length.



#### 8.6.4.2 Casement Sash Part Class Implementation

The casement sash part class stores the length of the casement sash part and the type of sash part (rail or stile). A method selects a stock size component for the part to be fabricated from based on the required length and the available inventory. The stock size length of the part is transmitted to the casement sash parts puller via the central database. The required length is transmitted to the casement sash part fabricator, who uses the data to cut the part to the correct length.

#### 8.6.4.3 Polygonal Frame Part Class Implementation

The polygonal frame part class stores the length of the polygonal frame part, the length of the stock size component that the part will be fabricated from, and the cut angles for each end of the part. The stock size length of the part is transmitted to the polygonal frame parts puller. The length and cut angles are transmitted to the polygonal frame part fabricator, who uses the data to cut the part to the correct length with the correct angles.

#### 8.6.4.4 Polygonal Sash Part Class Implementation

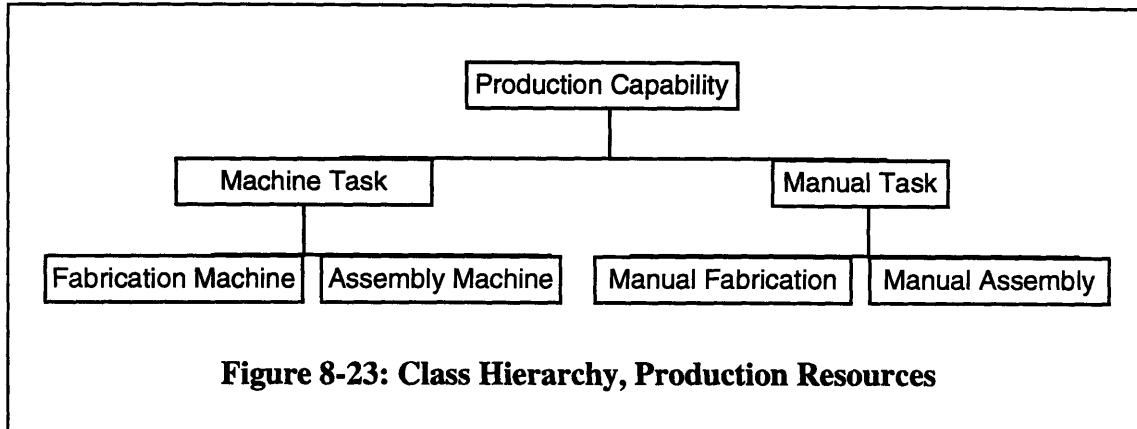
The polygonal sash part object must store the length of the polygonal sash part, the length of the stock size component that the part will be fabricated from, and the cut angles for each end of the part. The stock size length of the part is transmitted to the polygonal sash parts puller. The length and cut angles are transmitted to the polygonal sash part fabricator, who uses the data to cut the part to the correct length with the correct angles.

#### 8.6.4.5 Glazing Implementation

The information required to be stored in the glazing object includes the type of glass and the shape of the glazing. For CNC compatible glazings, the information is interpreted by the CNC post-processor. For non-CNC compatible glazings, the glazing object should generate a shop drawing and glass specification (type) and transmit the information to the manual glass cutting resource.

### 8.6.5 Production Resources

As shown in Figure 8-23, Production Capabilities are classified as Machine Tasks and Manual Tasks.



Objects that are instantiations of the Assembly Machine class include: a CNC Casement Frame Assembly Machine and a CNC Casement Sash Assembly Machine. Each object maintains its maximum and minimum sizes for assembled components and transmits the production plan to the virtual machine.

Objects that are instantiations of the Manual Assembly class include: the Manual Casement Frame Assembly Process and the Manual Casement Sash Assembly Process. Each object maintains its maximum and minimum sizes for assembled components, formats the process plan data for a worker (generating a bill of materials and a shop drawing) and transmits the plan to the virtual worker.

The CNC Glass Cutting Machine is an instantiation of the Fabrication Machine class. The object transmits the production plan to the virtual machine.

Objects that are instantiations of the Manual Fabrication class include: the Manual Glass Cutting Process, the Casement Frame Parts Fabricator, the Casement Sash Parts Fabricator, the Polygonal Frame Parts Fabricator, and the Polygonal Sash Parts Fabricator. Each object formats the process plan data for a worker (generating a work order, bill of materials, and/or shop drawing as needed) and transmits the plan to the virtual worker.

Objects that are instantiations of the Manual Task class include: the Casement Frame Parts Puller, the Casement Sash Parts Puller, the Polygonal Frame Parts Puller, and the Polygonal Sash Parts Puller. Each object formats the process plan data for a worker and transmits the plan to the virtual worker.

## **8.7 Conclusions and Application to other Components**

The approach described in this chapter shows how process plans can be automatically generated for a wide range of product variety. First, the kit of parts is modeled with an object class hierarchy. Second, the process plan is defined parametrically for the entire range of products that the manufacturing system is capable of producing. Third, the design validator prevents designs outside this envelope, essentially filtering them out of the process to prevent errors.

This approach can be applied to any products for which there exists a well-defined kit of parts and a well defined production process. Examples in the housing industry include: wood cabinet production, in which a large percentage of orders are custom or semi-custom; structural and non-structural wall framing panels, including both open wall and closed wall panels; prefabricated utility cores; and, modular and HUD-code homes. It is also applicable to other non-residential pre-assembled components, including: HVAC systems and ducts, elevators and escalators, and pre-engineered metal buildings.

This approach is not applicable to on-site general construction for several reasons. First, the range of products that can be produced is undefined. Essentially, anything can be built (so the kit of parts is unbounded). Second, planning in manufacturing and planning in construction differ in that construction planning is usually undertaken by a team of specialists, each knowledgeable about a particular aspect of the planning process,<sup>6</sup> while manufacturing process plans are generated by a single individual. For example, high level construction planning will be performed by a general contractor, but subcontractors (and tradesmen) will focus on detailed planning for their own processes. In short, the production resources are also undefined for on-site production since they differ from subcontractor to subcontractor. Thus, the required production planning information cannot be predefined in the object hierarchy.

The approach described in this chapter allows one to integrate a design system, human production resources and automated machines into an efficient production system. Manual production resources become linked to what are currently islands of automation and a CIM/IT infrastructure is created throughout design and production. As an ancillary benefit, it is easier to develop or adopt additional systems for automated material processing as task automation becomes cost effective. The process parameters of the new production resource must simply be defined and added to the planning system.

Computers have been used extensively in design, analysis, testing, and administrative functions, as well as to control production equipment, but the integration of these islands of computing resources is only beginning to occur. This integration will increase

---

<sup>6</sup>Yamazaki, Yasuke, "Integrated Design and Construction Planning System for Computer Integrated Construction," *Automation in Construction* 1 (1992) 21-26.



efficiency.<sup>7</sup> Off-site producers can build an information infrastructure throughout the firm to take advantage of the efficiencies of CIM. CIM and CAPP increase process flexibility by eliminating slow, costly, manual planning processes which hinder customization. Numerous off-site production systems for homebuilding can benefit from the technology.

In summary, this Chapter described an approach to how one can embed a representation of the production process in a design system and automatically generate the required instance specific information for flexible production. This capability results from that fact that the kit of parts is well defined for a specific range of product variety and there is a well defined process plan for a given factory environment. Thus, the process plan for a particular product becomes a collection of "scripts" which define how each component part is to be made. This approach is an implementation of variant process planning. The object oriented representation allows flexibility to be maintained by easily allowing the off-line creation of new parts and production resources as well as the modification of existing parts and resources. The prototype system shows that such an approach is feasible for automating the generation of process planning information for flexible off-site production in housing.

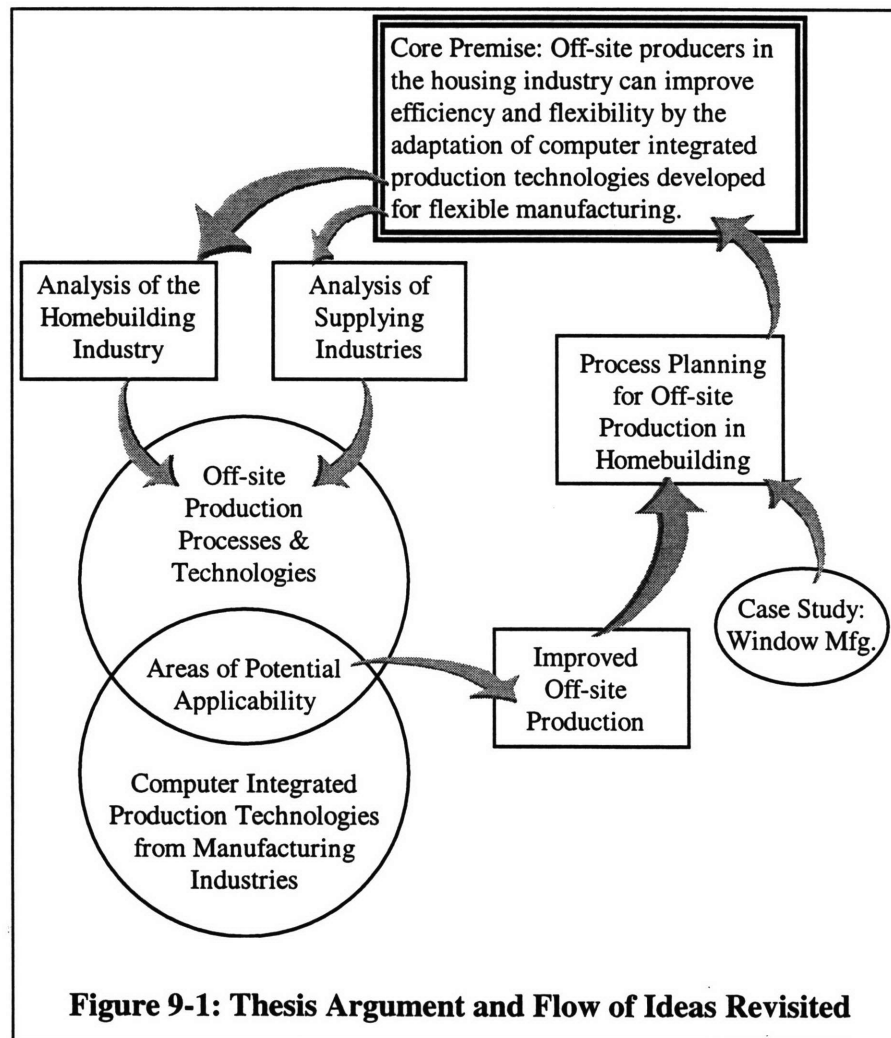
---

<sup>7</sup> Litke, H.D. and A.A. Voegelé, "Information Management and CAD/CAM - The New Challenge," 1985.

## 9. Summary and Conclusions

### 9.1 Summary of Content and Results

As stated in Chapter One, the overall purpose of this thesis was to develop an understanding of how the U.S. homebuilding industry can improve the effectiveness of its production processes by adopting flexible manufacturing system technologies. Figure 9-1 shows the diagram which was first presented in the Introduction and which graphically demonstrates the development of the thesis argument. The summary and conclusions provided here are presented in the context of this argument.



#### 9.1.1 Analysis of the Homebuilding Industry

The analysis of the structure of the homebuilding industry revealed that the housing industry is a huge, fragmented industry that exhibits many types of flexibility. However, the fragmentation and the extremely cyclical demand have contributed to a lack of

investment in dedicated production technologies (or other fixed costs). On-site, costs and production times are higher and quality is lower than they would be with dedicated off-site production resources.

### **9.1.2 Analysis of Supplying Industries**

The analysis of industries that supply housing showed that houses are composed of a vast number of products, most of which contribute a small portion to cost. The products are made by numerous supplying industries. However, components that are pre-assembled off-site collectively make up a significant contribution to value-added in housing. Component suppliers produce doors, windows, kitchen cabinets, wood trusses, framed wall panels, and prefabricated wood buildings. There is a substantial and growing demand for more customized production of these high-value components.

### **9.1.3 Off-site Production Processes and Technologies**

An examination of the production processes and technologies that are currently used in off-site production for housing found all types of production processes and technologies. Many materials are mass-produced with high volume mechanized processes, while modular housing production is dominated by manual processes similar to on-site production but with greater use of powered hand tools. At the center of this spectrum is the production of pre-assembled components, which typically utilizes special purpose (inflexible) machines. However, flexible, computer integrated systems are beginning to be used for some applications in components production.

### **9.1.4 Computer Integrated Production Technologies from Manufacturing Industries**

Chapter Five described the computer integrated production technologies utilized in flexible manufacturing systems. It was shown that automated process planning is a critical technology in flexible production, since instance-specific process information is required to make each unique part. Computer aided process planning systems have been largely constrained to applications with homogeneous production resources, such as in the machining industry. In off-site production in housing, diverse types of production resources exist, including: human workers, manually operated machines, computer controlled machines, and information processing systems.

### **9.1.5 Areas of Potential Overlap / Improved Off-site Production**

Chapter Six described a vision of how flexible manufacturing systems could be applied in housing production. It identified the potential benefits of the technology, including: higher quality, decreased cost, shorter production times, higher flexibility and other strategic benefits resulting from the increased flexibility and production capability. It also identified some of the barriers to adoption of the technologies. One barrier was the ability of process planning software to deal with diverse production resource types. Finally, the Chapter described how the vision conforms to the current best thinking in construction automation

research, in which high value pre-assembled components and subassemblies are installed on-site with “smart tools.”

#### **9.1.6 A Case Study in Window Manufacturing**

The case study at Marvin Windows further clarified off-site production. It illustrated some real world examples of design-manufacturing integration and presented the cost, quality, flexibility, and time benefits that have been realized in those cases. It also showed the inefficiency and difficulty of manual process planning in a flexible production environment. Window manufacturing utilizes multiple types of production resources. For flexible manufacturing, each of these resource types needs information in a timely manner and in a useful form.

#### **9.1.7 Process Planning for Off-site Production in Housing**

Chapter Eight presented an object oriented approach to process planning which is capable of dealing with both the diversity of production resources and the flexibility required. The approach takes advantage of the fact that homebuilding’s kit of parts is well defined, as is an off-site production system. The prototype system is implemented as an object oriented, parametrically defined, variant process planning system. Such a system can be used to develop an information technology infrastructure in an off-site factory.

#### **9.1.8 Core Premise Confirmed**

In summary, Chapters One and Two identified off-site pre-assembled components as an area where improved efficiency and flexibility could provide substantial benefit to the housing industry, both through increasing the efficiency and flexibility of production and by reducing wholesale and retail trade costs by linking flexible producers directly with builders. Chapters Four and Five confirmed that flexible manufacturing system technology can indeed be applied to off-site production, albeit in the context of the special purpose machines and the diverse production resources found off-site. Chapter Six presented a vision of off-site production under the new flexible manufacturing approach and showed how it fits with the current thinking in construction automation research toward smart-tools for on-site installation. Chapter Seven identified process planning as a significant contributor to cost and time in window manufacturing. Chapter Eight demonstrated how the flexible manufacturing approach can be implemented in off-site production of windows, drawing heavily on Chapter Seven’s detailed account of window production at the largest made to order window manufacturer in the world. The prototype system that was developed and described in Chapter Eight proved the feasibility of the variant process planning approach for a production system with diverse resources. Thus, flexible manufacturing system technology can be applied to off-site production in housing and will benefit the housing industry.

## **9.2 Contributions**

The contributions of this thesis correspond to the focal points of the thesis. The first contribution of the thesis is an analysis of the housing industry and of the industries that supply housing. This analysis identified off-site pre-assembled components as a class of input with high value added and high production flexibility required. The second contribution is an extensive review of the production technologies used in off-site production for housing and in traditional manufacturing environments. The review highlighted differences in the types of production systems, including the utilization of diverse resource types in off-site production in housing. The third contribution is the development and demonstration of an approach for applying the flexibility-enhancing, computer-aided process planning technology to a production environment with multiple resource types. The approach is novel in that CAPP has traditionally been applied only to automated production equipment such as machining systems. Feasibility of the approach is confirmed through the implementation of a hypothetical process planning system for flexible window production.

## **9.3 Recommendations for Further Work**

Although this thesis confirmed the feasibility of the approach, by no means does that ensure that the approach will be adopted by the industry. There are several areas where further work is warranted, primarily with regard to the efficient and timely deployment of real world systems. First, the integration with existing plant information systems should be studied more closely. It is the experience of the author that no standards exist for the integration of enterprise applications. Thus, integration may require a custom translator for each legacy system. Although this is technically feasible, it adds some degree of extra time and cost to a real world deployment. Second, the deployment of real world systems will require some type of object modeling and system development tools. It is possible that CASE (computer aided software engineering) tools could be used to model the class hierarchies and to generate code. This option should be explored. Finally, interface issues are influential in the widespread adoption of software. Some effort should be made toward developing user profiles for potential applications of the technology so that the optimal level of design abstraction and ease of use is ensured.

## **9.4 Final Comment**

*Time* magazine's "Man of the Year" for 1982 has clearly changed the world of manufacturing. This thesis has presented a vision of how it can improve off-site production in the housing industry. This author hopes it will come to pass.

# Appendix A : Housing Varieties and Consumer Preferences

This Appendix presents a description of the design variations and product varieties as well as a corresponding description of the consumer preference profiles for many of the features found in housing today. The information contained here is based on market surveys of consumer preferences and on industry statistics of what builders are actually building.

A house consists of an assembly of roughly twenty thousand pieces<sup>1</sup> chosen from a range of roughly an order of magnitude more parts. For example, the Japanese firm Sekisui House builds homes from a kit of over 330,000 parts. As consumer preferences evolve, builders choose different combinations of parts and reconfigure existing parts.

“The typical home of the future will be a two-story colonial with or without a basement (depending on location). It will be larger in size than today’s average home, but will sit on a smaller lot. New homes will have master bedrooms on both the first and second floors, with a master bathroom that has a separate shower and tub and two walk in closets. New homes will also contain a media room, an exercise room/area, a large and well-lighted kitchen, two full- and two half-baths, at least one fireplace, and a two- or three-car garage. But, in order to meet individual needs and tastes, few homes will be typical.”  
...Ahluwalia, 1991.<sup>2</sup>

## A1 . Architecture

Traditional architecture is preferred by more new home buyers than any other style, followed closely by contemporary (see Figure A-1). Combined, these two styles are preferred by nearly two out of three buyers.<sup>3</sup> Preferred architectural styles differ regionally, with West Coast and New England buyers preferring Contemporary styles and other regions preferring Traditional styles.<sup>4</sup> On the supply side, three of four new homes built are either Traditional or Contemporary architecture. It has been found that consumers would prefer that more homes be built with Contemporary, Colonial, Victorian, and Tudor architecture, and less with Traditional and Spanish architecture.

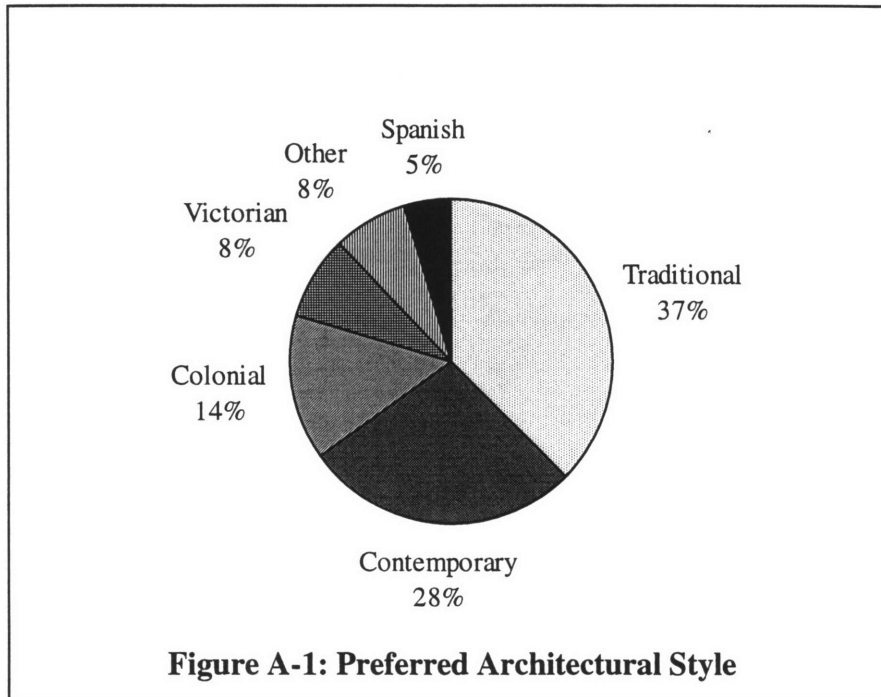
---

<sup>1</sup> Binsacca, Richard, “10 Steps to Zero Defects,” *Builder*, June, 1991.

<sup>2</sup> Ahluwalia, Gopal, “The House of the Future,” *Housing Economics*, June, 1991.

<sup>3</sup> Benderoff, Eric L., “What Buyers Want in Housing,” *Professional Builder*, December, 1989.

<sup>4</sup> Benderoff, Eric L., “What Buyers Want in Housing,” *Professional Builder*, December, 1989.



## A2 . Number of Stories

The share of one story homes built between 1971 and 1989 fell from seventy-three to forty-six percent, while two story homes rose in prevalence from seventeen to forty-nine percent.<sup>5</sup> Clearly, the trend is toward the construction of multi-story homes. According to surveys, consumer preferences agree with this trend. Professional Builder found that forty-three percent of 1990 home buyers preferred single story homes,<sup>6</sup> while Professional Builder and Remodeler found that forty-seven percent of 1991 home buyers preferred single story homes.<sup>7</sup> Essentially, consumers are split between single and multi-story homes, with a trend favoring multi-story homes. Split level homes represent a small and decreasing market share.

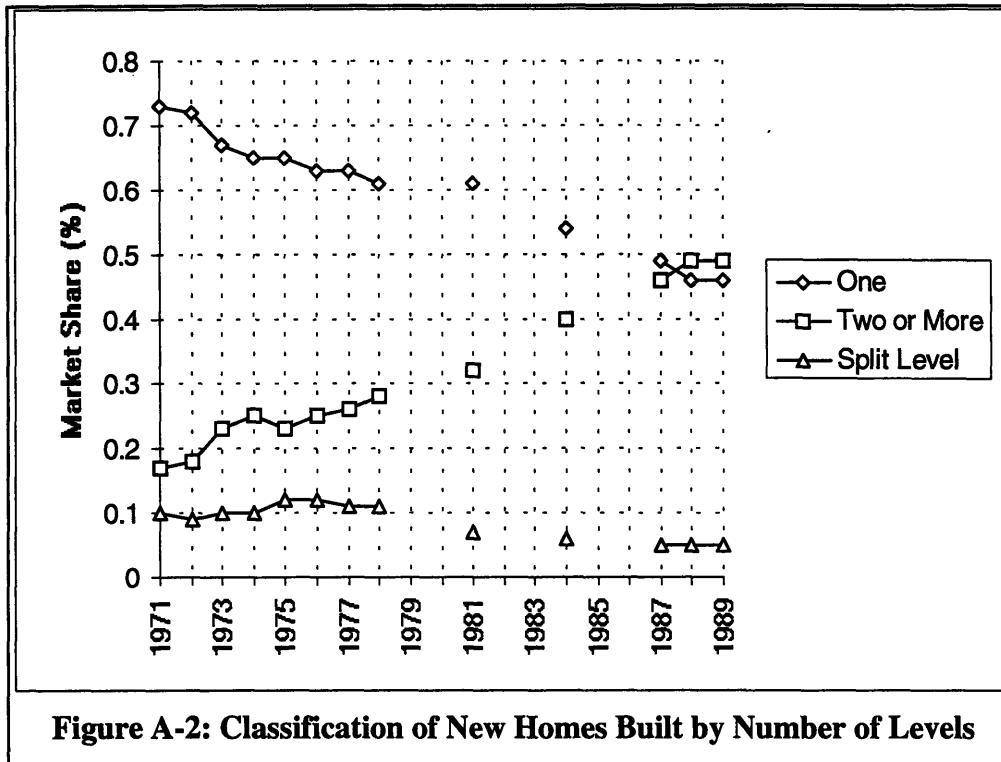
Regionally, two story homes are the most popular in New England, the Mid-Atlantic, and South-Atlantic regions, with single level homes more popular in other regions of the country.<sup>8</sup>

<sup>5</sup> Ahluwalia, Gopal, "Consumer Preferences for Design and Features," *Blueprint - Home Builders Association of Charlotte*, February, 1989.

<sup>6</sup> Benderoff, Eric L., "What Buyers Want in Housing," *Professional Builder*, December, 1989.

<sup>7</sup> Wells, Karen, "What 1991 Buyers Want in Housing," *Professional Builder & Remodeler*, December 1, 1990.

<sup>8</sup> Wells, Karen, "What 1991 Buyers Want in Housing," *Professional Builder & Remodeler*, December 1, 1990.



### A3 . Exterior Finishes

Although builders produce a wide variety of exterior finishes, the overall favorite exterior finish is brick. According to a National Association of Home Builders consumer preference survey, brick is preferred on the front exterior by fifty-two percent of homeowners and the side exterior by thirty-eight percent, while wood is preferred on the front exterior by only eleven percent of homeowners and the side exterior by eighteen percent.<sup>9</sup>

Regionally, the preferred exterior finish material varies widely.<sup>10</sup> In the Mid-Atlantic, South Atlantic, Central, and Mountain regions, brick is preferred. In the Northeast, more than two thirds of buyers prefer wood siding or wood shingle exteriors,<sup>11</sup> followed by vinyl siding and brick.<sup>12</sup> On the West Coast, stucco is the preferred material, followed by brick and wood siding.

<sup>9</sup> Ahluwalia, Gopal, and Michael Carliner, *What Home Buyers Want - Consumer Preference Survey Results*, National Association of Home Builders, Washington, D. C., 1989.

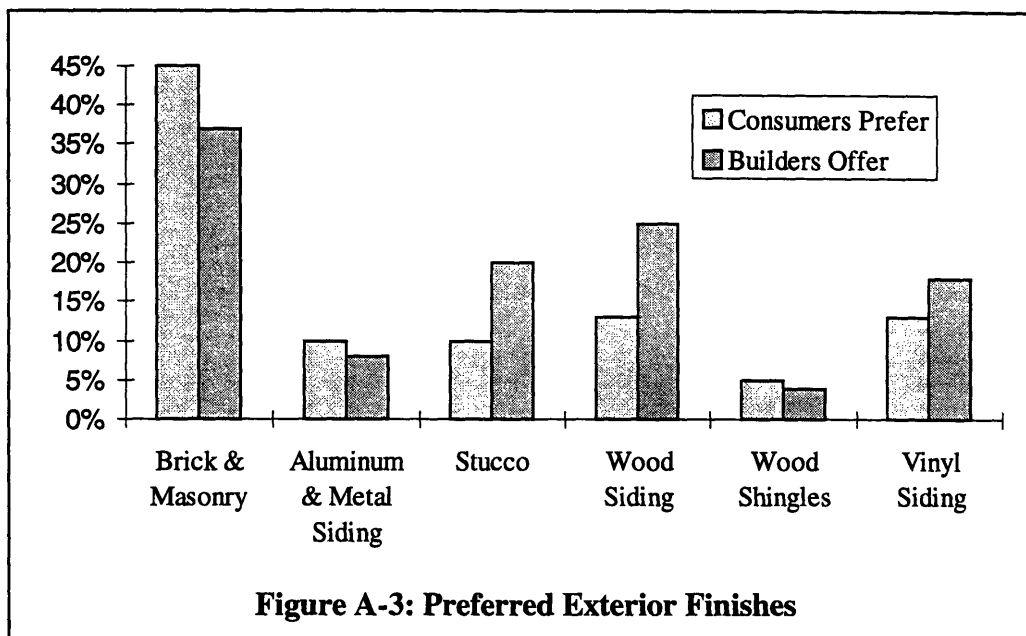
<sup>10</sup> Sichelman, Lew, "Innovation: Best From the West?" *Builder*, October, 1988

<sup>11</sup> Fletcher, June, "Trade Offs, 1989 Home Buyer Survey" *Builder*, November, 1989.

<sup>12</sup> Benderoff, Eric L., "What Buyers Want in Housing," *Professional Builder*, December, 1989.



Figure A-3 provides the results of a 1989 survey by Professional Builder.<sup>13</sup> It shows that builders are not supplying what consumers desire in exterior finishes. According to these results, builders use too much stucco, wood siding, and vinyl siding for exterior finishing and not enough brick, aluminum siding and wood shingles.



#### A4 . Roofing

Even roofing material, a product with which consumers have little interaction, has a wide range of product variety. Standard shingles (asphalt composition) are preferred by thirty-seven percent of consumers. Slate is the second most preferred roofing material.<sup>14</sup> Tile and wood shakes follow, each being preferred by twenty percent of consumers.<sup>15</sup> Roofing material preference also shows regional variations.

#### A5 . Exterior Doors and Windows

Entry doors come in many styles and configurations. It has been found that double doors are preferred over single doors, decorative wooden doors are preferred over decorative metal doors, and windows above or on the side of the door is favored over glass in the

---

<sup>13</sup> Benderoff, Eric L., "What Buyers Want in Housing," *Professional Builder*, December, 1989.

<sup>14</sup> Fletcher, June, "Trade Offs, 1989 Home Buyer Survey" *Builder*, November, 1989.

<sup>15</sup> Ahluwalia, Gopal, and Michael Carliner, *What Home Buyers Want - Consumer Preference Survey Results*, National Association of Home Builders, Washington, D. C., 1989.

door.<sup>16</sup> Within each configuration there is an enormous variety of styles which are available.

Wood is the most preferred material for windows, followed by clad wood. Metal windows are the least favored.<sup>17</sup> Double pane glass is standard, with low emissivity coatings and argon filled spaces becoming more popular. Currently, windows have an "R" rating of between three and four, and in the near future, R-5 will be standard. Storm windows are preferred by fifty-eight percent of new home buyers.<sup>18</sup> Special windows such as bay windows and skylights are very popular, and for high priced homes, are essential.<sup>19</sup>

## **A6 . Square footage**

The average square footage of new homes has increased over the past twenty years, as shown in Figure A-4. According to a National Association of Home Builders survey, home buyers want their new home to be about thirty percent larger than their present home.<sup>20</sup> In the nineties, the market for new homes will be dominated by move-up buyers who prefer bigger homes with more amenities. This demographic shift is expected to further increase the size of new homes. Ahluwalia writes that according to builders and architects, home buyers will compromise on amenities, but not on size.<sup>21</sup>

Sources do vary slightly in the actual numbers provided for the size of new homes, but are essentially in agreement. According to the NAHB, the average size of new homes increased from 1,520 to 1,905 square feet between 1971 and 1987.<sup>22</sup> Least-squares regression was applied to this data to forecast the average size of new homes in the future. According to this estimate, new homes will contain just over two thousand square feet by the end of the century (See Figure A-4).

---

<sup>16</sup> Fletcher, June, "Trade Offs, 1989 Home Buyer Survey" *Builder*, November, 1989.

<sup>17</sup> Fletcher, June, "Trade Offs, 1989 Home Buyer Survey" *Builder*, November, 1989.

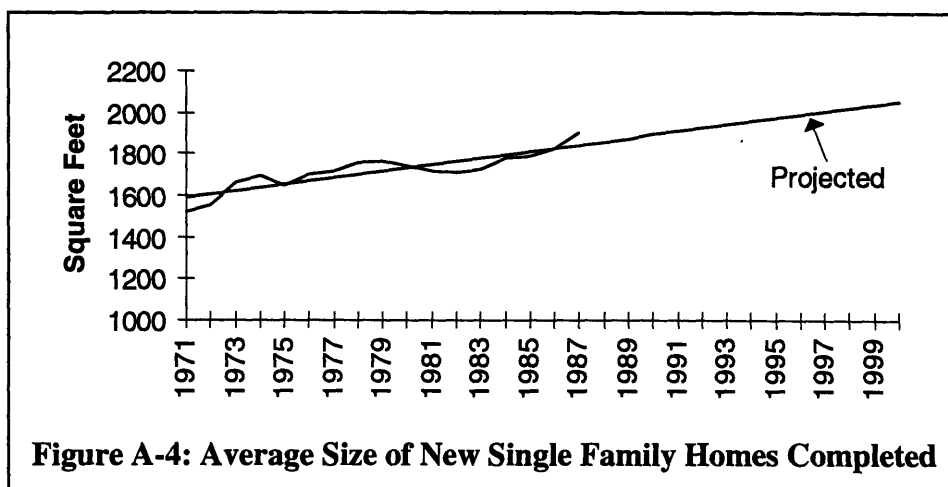
<sup>18</sup> Wells, Karen, "What 1991 Buyers Want in Housing," *Professional Builder & Remodeler*, December 1, 1990.

<sup>19</sup> Fletcher, June, "Trade Offs, 1989 Home Buyer Survey" *Builder*, November, 1989.

<sup>20</sup> Ahluwalia, Gopal, "Consumer Preferences for Design and Features," *Blueprint - Home Builders Association of Charlotte*, February, 1989.

<sup>21</sup> Ahluwalia, Gopal, "The House of the Future," *Housing Economics*, June, 1991.

<sup>22</sup> Sumicrast, Michael, et. al., *Housing Fact Book Housing and Housing Related Statistics*, National Association of Home Builders Economics Division, Washington, D. C.



Benderoff states that during the 1980's, the average home buyer expected roughly 1,900 square feet of usable space.<sup>23</sup> While Wells claims that in 1991, the median size of a detached home was 1,869 square feet.<sup>24</sup> (Note that the median size is expected to be smaller than the average size because the distribution is unbounded on the high side.) According to a survey by Builder magazine, the square footage desired by home buyers in 1989 ranged from 1,898 for single persons to 2,427 for couples with children. The average desired size was 2,342 square feet.<sup>25</sup>

## A7 . Basement

A full basement is preferred by roughly three of four home buyers.<sup>26</sup> The degree to which builders are satisfying this preference varies regionally (with climate and soil conditions). For example, in 1989, seventy-nine percent of homes built in New England and the Mid-West had full or partial basements, but in the South and West, fifty four and sixty-seven percent of homes, respectively, were built on a slab.

## A8 . Garage

Garages vary in the number of spaces provided as well as the number of garage doors. Surveys have found that between sixty-one percent<sup>27</sup> and sixty-six percent<sup>28</sup> to as many as

<sup>23</sup> Benderoff, Eric L., "What Buyers Want in Housing," *Professional Builder*, December, 1989.

<sup>24</sup> Wells, Karen, "What 1991 Buyers Want in Housing," *Professional Builder & Remodeler*, December 1, 1990.

<sup>25</sup> Fletcher, June, "Trade Offs, 1989 Home Buyer Survey" *Builder*, November, 1989.

<sup>26</sup> Shutt, Craig A., "What Homebuyers Want in 1989," *Building Supply Home Centers*, February, 1989.

<sup>27</sup> Benderoff, Eric L., "What Buyers Want in Housing," *Professional Builder*, December, 1989.

eighty-eight percent<sup>29</sup> of new home buyers prefer two car garages. Among homes completed in 1989, seventy percent had two or more car garages.<sup>30</sup> For two car garages, fifty-five percent of home buyers prefer a single garage door rather than two separate doors.<sup>31</sup>

## **A9 . Ceiling Height**

More than one third of survey respondents prefer eight foot ceilings, one fourth prefer nine foot ceilings, and thirty percent prefer ten or eleven feet. Although the most popular height is still eight feet, the trend in homebuilding is toward higher ceilings. Nine foot high ceilings are becoming more common, and today's luxury homes have ten foot ceilings on the entry level and nine foot ceilings on the second level.

## **A10 . Number of Bedrooms**

Between 1971 and 1978, sixty-four percent of new homes contained three bedrooms, twenty-four percent contained four or more bedrooms, and only twelve percent contained two bedrooms or less.<sup>32</sup> Today, three bedroom homes still comprise roughly half of new construction. A survey of 1991 new home buyers found that fifty-four percent favored three bedroom homes while thirty-five percent chose homes with four or more bedrooms.<sup>33</sup>

Buyers prefer master bedroom suites located on the first floor. This was true for all buyer types, from first time buyers (50.7 percent) to move up buyers (64.3 percent) to retirees (82.3 percent) and empty nesters (86.6 percent).<sup>34</sup> Walk-in closets are becoming standard

---

<sup>28</sup> Wells, Karen, "What 1991 Buyers Want in Housing," *Professional Builder & Remodeler*, December 1, 1990.

<sup>29</sup> Ahluwalia, Gopal, and Michael Carliner, *What Home Buyers Want - Consumer Preference Survey Results*, National Association of Home Builders, Washington, D. C., 1989.

<sup>30</sup> Carliner, Michael, "Characteristics of 1989 Homes," *Housing Economics*, August 1990.

<sup>31</sup> Ahluwalia, Gopal, and Michael Carliner, *What Home Buyers Want - Consumer Preference Survey Results*, National Association of Home Builders, Washington, D. C., 1989.

<sup>32</sup> Sumicrast, Michael, et. al., *Housing Fact Book Housing and Housing Related Statistics*, National Association of Home Builders Economics Division, Washington, D. C.

<sup>33</sup> Wells, Karen, "What 1991 Buyers Want in Housing," *Professional Builder & Remodeler*, December 1, 1990.

<sup>34</sup> Wells, Karen, "What 1991 Buyers Want in Housing," *Professional Builder & Remodeler*, December 1, 1990.

in master bedrooms. Eighty percent of home buyers want at least one in the master bedroom<sup>35</sup>

## A11 . Number of Bathrooms

As shown in Figure A-5, the percentage of new homes completed and sold having 2½ or more bathrooms has been rising in recent years, with forty-four percent of 1989 homes having 2½ or more bathrooms.<sup>36</sup> However, the number of bathrooms desired by home buyers is not in complete agreement with the number in recently built homes. According to a 1990 survey by Professional Builder, the average number of bathrooms desired by new home buyers is 2.3, which probably corresponds to a mode of the distribution of two bathrooms. Professional Builder & Remodeler's survey of 1991 new home buyers found that forty-three percent prefer two baths.<sup>37</sup> However, Ahluwalia writes that seventy percent of home buyers would like 2½ or more bathrooms,<sup>38</sup> and that two full and two half baths will be standard in homes built during the 1990's.<sup>39</sup> This apparent discrepancy can be explained by the fact that Ahluwalia's survey consisted predominantly of move-up buyers, while the others were based on a more uniform distribution of buyer type.

---

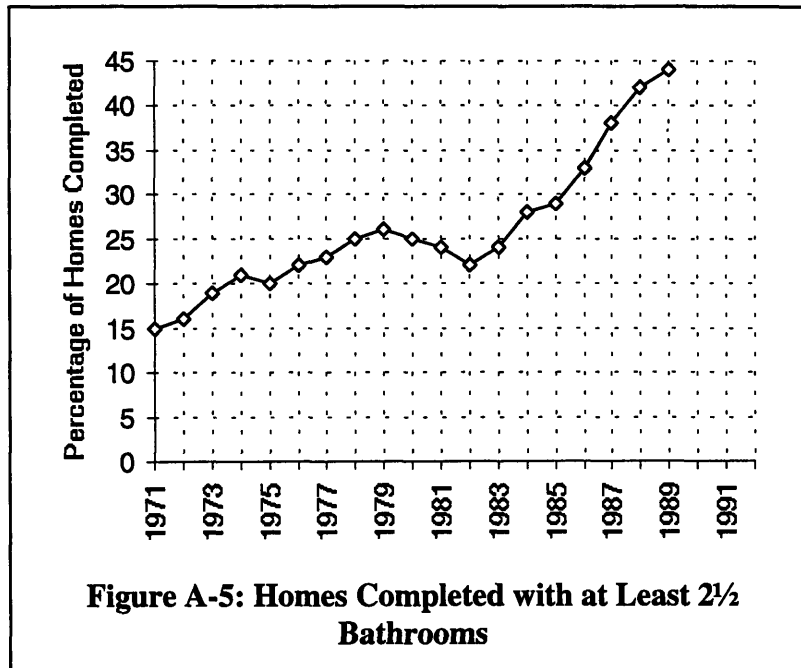
<sup>35</sup> Ahluwalia, Gopal, "Consumer Preferences for Design and Features," *Blueprint - Home Builders Association of Charlotte*, February, 1989.

<sup>36</sup> Carliner, Michael, "Characteristics of 1989 Homes," *Housing Economics*, August 1990.

<sup>37</sup> Wells, Karen, "What 1991 Buyers Want in Housing," *Professional Builder & Remodeler*, December 1, 1990.

<sup>38</sup> Ahluwalia, Gopal, "Consumer Preferences for Design and Features," *Blueprint - Home Builders Association of Charlotte*, February, 1989.

<sup>39</sup> Ahluwalia, Gopal, "The House of the Future," *Housing Economics*, June, 1991.



## A12 . Bathroom Amenities

In the nineties, bathroom amenities will increase, with increased use of high quality flooring, marble vanities, and linen closets.<sup>40</sup> Seventy percent of home buyers surveyed want two-bowl vanities in the master bathroom.<sup>41</sup> Other popular amenities include an exhaust fan (desired by eighty-seven percent of respondents), a medicine cabinet (by eighty-five percent), linen storage (by eighty-three percent), a tub/shower door (by sixty four percent), ceramic tile walls (by forty-seven percent), and a bathroom heater (by forty percent).<sup>42</sup>

## A13 . Kitchens and Kitchen Amenities

Eat-in kitchens are standard for virtually all types of homes. In addition, fifty-eight percent of home buyers prefer separate dining rooms. Buyers prefer kitchens with center islands, and walk-in pantries are favored by seventy-eight percent of surveyed home buyers.<sup>43</sup> The

<sup>40</sup> Ahluwalia, Gopal, "The House of the Future," *Housing Economics*, June, 1991.

<sup>41</sup> Ahluwalia, Gopal, "Consumer Preferences for Design and Features," *Blueprint - Home Builders Association of Charlotte*, February, 1989.

<sup>42</sup> Wells, Karen, "What 1991 Buyers Want in Housing," *Professional Builder & Remodeler*, December 1, 1990.

<sup>43</sup> Ahluwalia, Gopal, and Michael Carliner, *What Home Buyers Want - Consumer Preference Survey Results*, National Association of Home Builders, Washington, D. C., 1989.

most popular type of sink is a double stainless steel sink. The most popular type of kitchen lighting is fluorescent, which fifty-two percent of home buyers prefer.<sup>44</sup>

Like bathroom amenities, kitchen amenities are also on the rise. Designs featuring more than average amount of counter space are popular, with additional drop leaf counter space being preferred by sixty-one percent of buyers and center island counter space being preferred by fifty percent. Other preferred kitchen features include special use storage (by sixty-one percent), bay windows (sixty-two percent), and built in microwaves (sixty-nine percent).

Wood cabinets are much preferred over laminates or laminates with wood trim.<sup>45</sup> Larger and more kitchen cabinets are also preferred.

Kitchen appliances that are typically supplied by the builder include a range/oven (by ninety-three percent), a dishwasher (by ninety-three percent), and a garbage disposal by seventy-nine percent, while refrigerators were only included by eighteen percent of builders (but fifty-eight percent of consumers wanted them).<sup>46</sup>

## **A14 . Laundry Facilities**

Only nine percent of surveyed respondents preferred the washer and dryer in the basement. Forty-four percent preferred a special utility room, nineteen percent preferred a separate area near the kitchen, and nineteen percent said in a special place near bedrooms.<sup>47</sup>

## **A15 . Flooring Material**

In the entry foyer, ceramic tile is preferred by forty percent of homeowners, with twenty-seven percent choosing hardwood. In the living room, wall to wall carpet is preferred by eighty-four percent, while fifteen percent prefer hardwood. In the dining room, fifty-eight percent prefer wall to wall carpeting, while thirty-one percent prefer hardwood. In the family room/den, seventy-nine percent chose carpet and fifteen percent chose hardwood. In the kitchen, forty-four percent chose vinyl sheet, twenty-two percent ceramic tile, and seventeen percent vinyl tile. In the bedrooms, ninety-one percent chose wall to wall carpeting. In the bathrooms, forty-five percent chose ceramic tile, twenty-eight percent

---

<sup>44</sup> Wells, Karen, "What 1991 Buyers Want in Housing," *Professional Builder & Remodeler*, December 1, 1990.

<sup>45</sup> Fletcher, June, "Trade Offs, 1989 Home Buyer Survey" *Builder*, November, 1989.

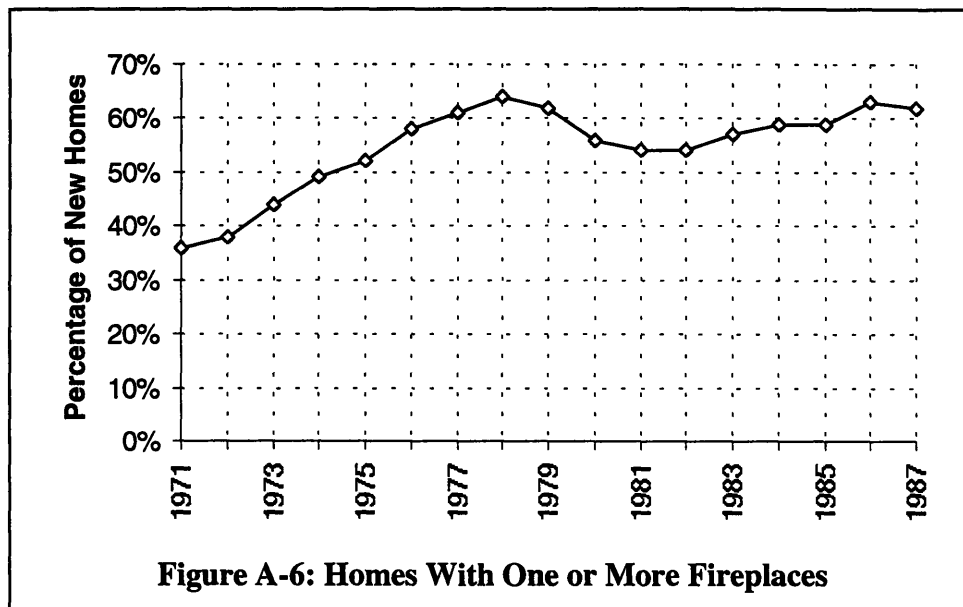
<sup>46</sup> Jones, Mary Beth, "Amenities in New Homes," *Housing Economics*, April, 1990.

<sup>47</sup> Ahluwalia, Gopal, and Michael Carliner, *What Home Buyers Want - Consumer Preference Survey Results*, National Association of Home Builders, Washington, D. C., 1989.

chose vinyl sheet, thirteen percent chose wall to wall carpeting, and twelve percent chose vinyl tiles. In hallways, seventy-five percent prefer wall to wall carpet, with fifteen percent choosing hardwood.<sup>48</sup>

## A16 . Fireplaces

Percentage of homes completed with one or more fireplaces has grown over the past two decades, as shown in Figure A-6.<sup>49</sup> Nearly two-thirds of new homes built in 1988-1989 had at least one fireplace.<sup>50</sup> Surrounding the fireplace, most surveyed buyers preferred brick, followed closely by stone, with marble the third choice.<sup>51</sup>



## A17 . Heating, Ventilation, and Air Conditioning System

As shown in Figure A-7, central air conditioning has become a standard item in new homes, with seventy-one percent of new homes having it installed and seventy-six percent of surveyed home buyers preferring it.<sup>52</sup> Zoned heating systems are becoming more

<sup>48</sup> Ahluwalia, Gopal, and Michael Carliner, *What Home Buyers Want - Consumer Preference Survey Results*, National Association of Home Builders, Washington, D. C., 1989.

<sup>49</sup> Sumicrast, Michael, et. al., *Housing Fact Book Housing and Housing Related Statistics*, National Association of Home Builders Economics Division, Washington, D. C.

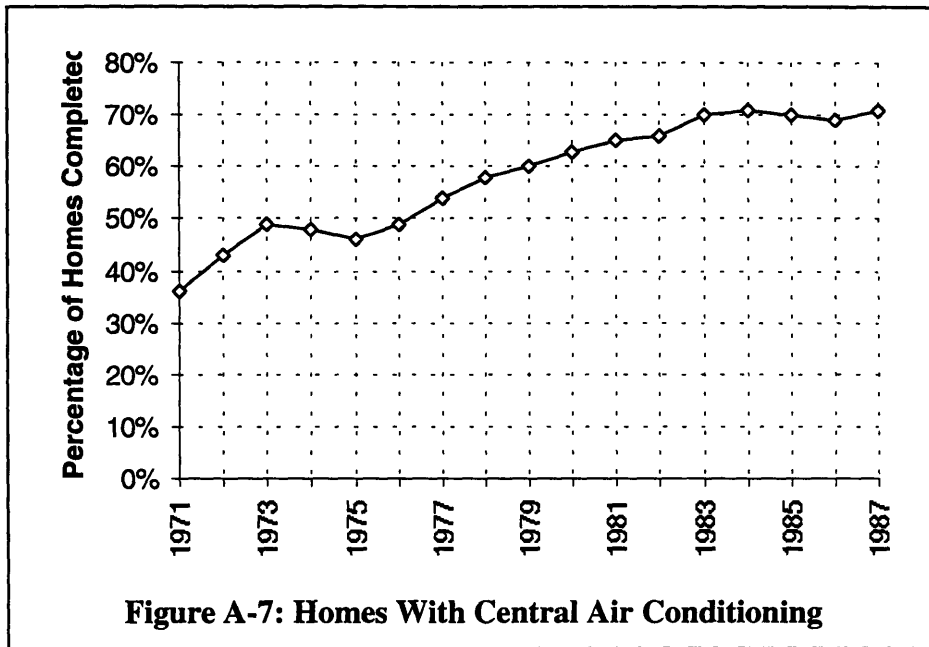
<sup>50</sup> Carliner, Michael, "Characteristics of 1989 Homes", *Housing Economics*, August, 1990.

<sup>51</sup> Fletcher, June, "Trade Offs, 1989 Home Buyer Survey" *Builder*, November, 1989.

<sup>52</sup> Ahluwalia, Gopal, and Michael Carliner, *What Home Buyers Want - Consumer Preference Survey Results*, National Association of Home Builders, Washington, D. C., 1989.



popular since they are more efficient and are better able to provide comfortable conditions throughout the house. Gas heat has grown from thirty-seven percent of new construction to fifty-eight percent in 1989.<sup>53</sup>



## A18 . Summary

There are numerous varieties, styles, and options that are offered by builders and desired by different consumers. This Appendix provided a very brief overview of some of the variety. It is important to note that preferences vary regionally and change over time due to demographic shifts and changing tastes. However, in spite of all the differences described in this Appendix, housing is essentially similar in choice of materials and more importantly for this Thesis, in the method of construction. In other words, the wide variety of materials and designs are essentially interchangeable and are fabricated in a similar manner.

Nonetheless, when considering process changes for housing, it is essential to consider the extremely high degree of product flexibility currently provided by the industry, as well as the near certainty of changes to the product mix over time.

---

<sup>53</sup> Jones, Mary Beth, "Amenities in New Homes," *Housing Economics*, April, 1990.

# Appendix B: Code Excerpts

## B1: Casement Windows

### *B1.1 Casement Window Class*

```
\(Declarations)
Option Explicit
Public itsFrame As New CasementFrame
Public itsSash As New CasementSash
Dim theFrameWidth As Double
Dim theFrameHeight As Double
Dim itsID As Long
Dim AssemblyResource As Integer
Dim theInteriorPrimed As Boolean
Dim theExteriorFinish As String
Dim theColorMatchNumber As Long
Dim theJambExtension As Double
Dim theDripCap As Boolean
Dim theClearBrickMoldCasing As Boolean
Dim theClearSill As Boolean
Dim theMuntinType As String
Dim theScreen As Boolean
Dim theStormPanel As Boolean

Public Sub Define(ByVal theID As Long)
    ' Instantiate Window
    ' Read Casement Window DB, call define methods
    itsID = theID
    MainForm.CMWindows.Refresh
    MainForm.CMWindows.Recordset.MoveFirst
    Do Until MainForm.CMWindows.Recordset.EOF
        If MainForm.CMWindows.Recordset.ID = theID Then
            ' Read Entry
            theFrameWidth=MainForm.CMWindows.Recordset.FrameWidth
            theFrameHeight=MainForm.CMWindows.Recordset.FrameHeight
            theInteriorPrimed=MainForm.CMWindows.Recordset.InteriorPrimed
            theExteriorFinish=MainForm.CMWindows.Recordset.ExteriorFinish
            theColorMatchNumber=MainForm.CMWindows.Recordset.ColorMatchNumber
            theJambExtension = MainForm.CMWindows.Recordset.JambExtension
            theDripCap = MainForm.CMWindows.Recordset.DripCap
            theClearBrickMoldCasing=
                MainForm.CMWindows.Recordset.ClearBrickMoldCasing
            theClearSill = MainForm.CMWindows.Recordset.ClearSill
            theMuntinType = MainForm.CMWindows.Recordset.MuntinType
            theScreen = MainForm.CMWindows.Recordset.Screen
            theStormPanel = MainForm.CMWindows.Recordset.StormPanel
        End If
        MainForm.CMWindows.Recordset.MoveNext    ' Move to next record.
    Loop
    ' Define Window Parts
    itsFrame.DefineWidth (theFrameWidth)
```

```

        itsFrame.DefineHeight (theFrameHeight)
        itsFrame.DefineParts
        itsSash.DefineWidth (theFrameWidth - itsFrame.GetJambOffset)
        itsSash.DefineHeight (theFrameHeight - itsFrame.GetHeaderOffset)
        itsSash.DefineParts (itsID)
    End Sub

    Public Sub Make()
        itsFrame.Make
        itsSash.Make
    End Sub

```

## *B1.2 Casement Frame Class*

```

' (Declarations)
Option Explicit
Dim AssemblyResource As Integer
Dim Width As Double
Dim Height As Double
Dim itsHeader As New CasementFramePart
Dim itsLeftJamb As New CasementFramePart
Dim itsRightJamb As New CasementFramePart
Dim itsSill As New CasementFramePart

Public Sub DefineParts()
    ChooseAssemblyResource
    itsHeader.SetPartUse (HEADER)
    itsHeader.Define (Width)
    itsLeftJamb.SetPartUse (LEFT_JAMB)
    itsLeftJamb.Define (Height)
    itsRightJamb.SetPartUse (RIGHT_JAMB)
    itsRightJamb.Define (Height)
    itsSill.SetPartUse (SILL)
    itsSill.Define (Width)
End Sub

Public Sub Make()
    ' Create DB Entry for CM Frame
    Dim MyWorkspace As Workspace, MyDatabase As Database
    Dim MyTable As Recordset
    Dim ErrorCondition As Integer
    Dim TableName As String
    Dim UpdateDb As Boolean
    UpdateDb = True
    On Error GoTo DBErrorHandler ' Enable error trapping.
    Set MyWorkspace = Workspaces(0)
    ' Open database
    Set MyDatabase = MyWorkspace.OpenDatabase(theDBFile)
    If Not ErrorCondition Then
        On Error GoTo TableErrorHandler ' Enable error trapping.

        ' Open table.
        If AssemblyResource = CNC Then
            TableName = "ProcCMFramePartsCNC"
        Else ' AssemblyResource = CNC
            TableName = "ProcCMFrameParts"
        End If
    End If

```

```

Set MyTable = MyDatabase.OpenRecordset(TableName)
If Not ErrorCondition Then
    On Error GoTo ErrorHandler ' Enable error trapping.
    'Add Part to List
    MyTable.AddNew
    MyTable![Header Stock Size] = itsHeader.GetStockSize
    MyTable![Sill Stock Size] = itsSill.GetStockSize
    MyTable![LeftJamb Stock Size] = itsLeftJamb.GetStockSize
    MyTable![RightJamb Stock Size] = itsRightJamb.GetStockSize
    MyTable![Header Cut Size] = Width
    MyTable![Sill Cut Size] = Width
    MyTable![LeftJamb Cut Size] = Height
    MyTable![RightJamb Cut Size] = Height
    If UpdateDb Then MyTable.Update
    MyTable.Close ' Close table.
End If
MyDatabase.Close ' Close database.
End If

GoTo endFunction
'Catch Errors
DEErrorHandler:
    ErrorCondition = True
    UpdateDb = False
    MsgBox "Can't open database.", vbExclamation
    Resume Next
TableErrorHandler:
    ErrorCondition = True
    UpdateDb = False
    MsgBox "Can't open Casement Frame Parts Pulling Process table.",
        vbExclamation
    Resume Next
EditErrorHandler:
    ErrorCondition = True
    UpdateDb = False
    MsgBox "Can't add record to Casement Frame Parts Pulling Process table.",
        vbExclamation
    Resume Next
endFunction:

End Sub

```

### *B1.3Casement Frame Part Class*

```

'(Declarations)
Option Explicit
Dim Thickness As Double
Dim Length As Double
Dim itsResource As Single
Dim PartUse As Integer

Public Sub Define(ByVal aDimension As Double)
    Length = aDimension
    If PartUse = HEADER Then
        Thickness = CASEMENT_HEADER_THICKNESS
    Else
        If PartUse = SILL Then

```

```

        Thickness = CASEMENT_SILL_THICKNESS
    Else
        If PartUse = LEFT_JAMB Then
            Thickness = CASEMENT_LEFT_JAMB_THICKNESS
        Else
            If PartUse = RIGHT_JAMB Then
                Thickness = CASEMENT_RIGHT_JAMB_THICKNESS
            End If
        End If
    End If
End If
End Sub

```

```

Function GetStockSize()
    Dim MyWorkspace As Workspace, MyDatabase As Database
    Dim MyTable As Recordset
    Dim ErrorCondition As Integer
    Dim theSize As Double
    Dim flag As Boolean

    flag = False
    On Error GoTo DBErrorHandler ' Enable error trapping.
    Set MyWorkspace = Workspaces(0)
    ' Open database
    Set MyDatabase = MyWorkspace.OpenDatabase(theDBFile)
    If Not ErrorCondition Then
        On Error GoTo TableErrorHandler ' Enable error trapping.
        ' Open table and find entry
        If PartUse = HEADER Then
            Set MyTable = MyDatabase.OpenRecordset("InvCMFrameHeader")
            If Not ErrorCondition Then
                On Error GoTo EditErrorHandler ' Enable error trapping.
                MyTable.Index = "Size" ' Define current index.
                MyTable.Seek ">=", Length ' Seek record.
                If MyTable.NoMatch Then
                    flag = False
                Else
                    flag = True
                    theSize = MyTable![Size]
                End If
                MyTable.Close ' Close table.
                If flag = False Then GoTo StockErrorHandler
            End If
        Else
            If PartUse = SILL Then
                Set MyTable = MyDatabase.OpenRecordset("InvCMFrameSill")
                If Not ErrorCondition Then
                    On Error GoTo EditErrorHandler ' Enable error trapping.
                    MyTable.MoveFirst
                    MyTable.Index = "Size" ' Define current index.
                    MyTable.Seek ">=", Length ' Seek record.
                    If MyTable.NoMatch Then
                        flag = False
                    Else
                        flag = True
                        theSize = MyTable![Size]
                    End If
                    MyTable.Close ' Close table.
                End If
            End If
        End If
    End If
End Function

```

```

        If flag = False Then GoTo StockErrorHandler
    End If
Else
    If PartUse = LEFT_JAMB Then
        Set MyTable = MyDatabase.OpenRecordset("InvCMFrameJamb")
        If Not ErrorCondition Then
            On Error GoTo EditErrorHandler ' Enable error trapping.
            MyTable.MoveFirst
            MyTable.Index = "Size" ' Define current index.
            MyTable.Seek ">=", Length ' Seek record.
            If MyTable.NoMatch Then
                flag = False
            Else
                flag = True
                theSize = MyTable![Size]
            End If
            MyTable.Close ' Close table.
            If flag = False Then GoTo StockErrorHandler
        End If
    Else
        If PartUse = RIGHT_JAMB Then
            Set MyTable = MyDatabase.OpenRecordset("InvCMFrameJamb")
            If Not ErrorCondition Then
                On Error GoTo EditErrorHandler ' Enable error trapping.
                MyTable.MoveFirst
                MyTable.Index = "Size" ' Define current index.
                MyTable.Seek ">=", Length ' Seek record.
                If MyTable.NoMatch Then
                    flag = False
                Else
                    flag = True
                    theSize = MyTable![Size]
                End If
                MyTable.Close ' Close table.
                If flag = False Then GoTo StockErrorHandler
            End If
        End If
    End If
End If
End If
End If
End If
MyDatabase.Close ' Close database.
End If

GoTo endFunction
DEErrorHandler:
    ErrorCondition = True
    MsgBox "Can't open database.", vbExclamation
    Resume Next
TableErrorHandler:
    ErrorCondition = True
    MsgBox "Can't open table.", vbExclamation
    Resume Next
EditErrorHandler:
    ErrorCondition = True
    MsgBox "Can't read from Casement Frame Part Inventory table.",
        vbExclamation
    Resume Next
StockErrorHandler:
    ErrorCondition = True
    MsgBox "No stock is available to make this part", vbExclamation

```

```

    Resume Next
endFunction:
GetStockSize = theSize
End Function

```

```

Public Function GetThickness() As Double
    GetThickness = Thickness
End Function

```

```

Public Sub SetPartUse(ByVal aPartUse As Integer)
    PartUse = aPartUse
End Sub

```

```

Public Sub SetResource(ByVal theResource As Integer)
    itsResource = theResource
End Sub

```

```

Public Sub Make(ByVal theID As Long)
    Dim MyWorkspace As Workspace, MyDatabase As Database
    Dim MyTable As Recordset
    Dim ErrorCondition As Integer
    Dim UpdateDb As Boolean

    UpdateDb = True
    On Error GoTo DBErrorHandler ' Enable error trapping.
    Set MyWorkspace = Workspaces(0)
    ' Open database
    Set MyDatabase = MyWorkspace.OpenDatabase(theDBFile)
    If Not ErrorCondition Then
    On Error GoTo TableErrorHandler ' Enable error trapping.

    ' Open table.
    Set MyTable = MyDatabase.OpenRecordset("ProcCMFrameParts")
    If Not ErrorCondition Then
        On Error GoTo EditErrorHandler ' Enable error trapping.
        'Add Part to List
        MyTable.Index = "ID"
        MyTable.Seek "=", theID 'Find correct record
        If PartUse = HEADER Then
            MyTable![Header Cut Size] = Length 'Populate Record
            MyTable![Header Stock Size] = GetStockSize
        Else
            If PartUse = SILL Then
                MyTable![Sill Cut Size] = Length
                MyTable![Sill Stock Size] = GetStockSize
            Else
                If PartUse = LEFT_JAMB Then
                    MyTable![LeftJamb Cut Size] = Length
                    MyTable![LeftJamb Stock Size] = GetStockSize
                Else
                    If PartUse = RIGHT_JAMB Then
                        MyTable![RightJamb Cut Size] = Length
                        MyTable![RightJamb Stock Size] = GetStockSize
                    End If
                End If
            End If
        End If
    End If
End Sub

```

```

        End If
        If UpdateDb Then MyTable.Update ' Save Changes
        MyTable.Close ' Close table.
    End If
    MyDatabase.Close ' Close database.
End If
GoTo endFunction
DErrorHandler:
    ErrorCondition = True
    UpdateDb = False
    MsgBox "Can't open database.", vbExclamation
    Resume Next
TableErrorHandler:
    ErrorCondition = True
    UpdateDb = False
    MsgBox "Can't open Casement Frame Parts Pulling Process table.",
        vbExclamation
    Resume Next
EditErrorHandler:
    ErrorCondition = True
    UpdateDb = False
    MsgBox "Can't enter data to Casement Frame Parts Pulling Process table.",
        vbExclamation
    Resume Next
endFunction:
End Sub

```

#### *B1.4Casement Sash Class*

```

'(Declarations)
Dim AssemblyResource As Integer
Dim Width As Double
Dim Height As Double
Dim itsTopRail As New CasementSashPart
Dim itsLeftStile As New CasementSashPart
Dim itsRightStile As New CasementSashPart
Dim itsBottomRail As New CasementSashPart
Dim itsGlazingAssembly As New GlazingAssembly

Public Sub DefineParts(ByVal CasementID As Long)
    ChooseAssemblyResource
    itsTopRail.SetPartUse (TOP_RAIL)
    itsTopRail.Define (Width)
    itsLeftStile.SetPartUse (LEFT_STILE)
    itsLeftStile.Define (Height)
    itsRightStile.SetPartUse (RIGHT_STILE)
    itsRightStile.Define (Height)
    itsBottomRail.SetPartUse (BOTTOM_RAIL)
    itsBottomRail.Define (Width)
    itsGlazingAssembly.DefineNumPoints (4)
    'point 1
    itsGlazingAssembly.SetX (0#)
    itsGlazingAssembly.SetY (0#)
    'point 2
    itsGlazingAssembly.SetX (Width - GetStileOffset)

```



```

itsGlazingAssembly.SetY (0#)
'point 3
itsGlazingAssembly.SetX (Width - GetStileOffset)
itsGlazingAssembly.SetY (Height - GetRailOffset)
'point 4
itsGlazingAssembly.SetX (0#)
itsGlazingAssembly.SetY (Height - GetRailOffset)
itsGlazingAssembly.DefineParts (CasementID)
End Sub

Public Sub Make()
'Create DB Entry for CM Sash
Dim theID As Long
Dim MyWorkspace As Workspace, MyDatabase As Database
Dim MyTable As Recordset
Dim ErrorCondition As Integer
Dim TableName As String
Dim UpdateDb As Boolean

itsGlazingAssembly.Make
UpdateDb = True
On Error GoTo DBErrorHandler ' Enable error trapping.
Set MyWorkspace = Workspaces(0)
' Open database
Set MyDatabase = MyWorkspace.OpenDatabase(theDEFfile)
If Not ErrorCondition Then
On Error GoTo TableErrorHandler ' Enable error trapping.
' Open table.
If AssemblyResource = CNC Then
TableName = "ProcCMSashPartsCNC"
Else 'AssemblyResource = CNC
TableName = "ProcCMSashParts"
End If
Set MyTable = MyDatabase.OpenRecordset(TableName)
If Not ErrorCondition Then
On Error GoTo EditErrorHandler ' Enable error trapping.
'Add Part to List
MyTable.AddNew
MyTable![TopRail Stock Size] = itsTopRail.GetStockSize
MyTable![BottomRail Stock Size] = itsBottomRail.GetStockSize
MyTable![LeftStile Stock Size] = itsLeftStile.GetStockSize
MyTable![RightStile Stock Size] = itsRightStile.GetStockSize
MyTable![TopRail Cut Size] = Width
MyTable![BottomRail Cut Size] = Width
MyTable![LeftStile Cut Size] = Height
MyTable![RightStile Cut Size] = Height
If UpdateDb Then MyTable.Update
MyTable.Close ' Close table.
End If
MyDatabase.Close ' Close database.
End If
GoTo endFunction

'Catch Errors
DBErrorHandler:
ErrorCondition = True
UpdateDb = False
MsgBox "Can't open database.", vbExclamation
Resume Next

```

```

TableErrorHandler:
    ErrorCondition = True
    UpdateDb = False
    MsgBox "Can't open Casement Sash Parts Pulling Process table.",
        vbExclamation
    Resume Next
EditErrorHandler:
    ErrorCondition = True
    UpdateDb = False
    MsgBox "Can't add record to Casement Sash Parts Pulling Process table.",
        vbExclamation
    Resume Next
endFunction:
End Sub

```

### *B1.5Casement Sash Part Class*

```

Option Explicit

Dim thickness As Double
Dim Length As Double
Dim itsResource As Single
Dim PartUse As Integer

Public Sub Define(ByVal aDimension As Double)

    Length = aDimension

    If PartUse = TOP_RAIL Then
        thickness = CASEMENT_TOP_RAIL_THICKNESS
    Else
        If PartUse = BOTTOM_RAIL Then
            thickness = CASEMENT_BOTTOM_RAIL_THICKNESS
        Else
            If PartUse = LEFT_STYLE Then
                thickness = CASEMENT_LEFT_STYLE_THICKNESS
            Else
                If PartUse = RIGHT_STYLE Then
                    thickness = CASEMENT_RIGHT_STYLE_THICKNESS
                End If
            End If
        End If
    End If
End If

End Sub

Function GetStockSize()

Dim MyWorkspace As Workspace, MyDatabase As Database
Dim MyTable As Recordset

Dim ErrorCondition As Integer

Dim theSize As Double
Dim flag As Boolean
Dim UpdateDb As Boolean

```

```

UpdateDb = True
flag = False

On Error GoTo DBErrorHandler ' Enable error trapping.

Set MyWorkspace = Workspaces(0)
' Open database
Set MyDatabase = MyWorkspace.OpenDatabase(theDEFfile)
If Not ErrorCondition Then
    On Error GoTo TableErrorHandler ' Enable error trapping.

    ' Open table and find entry
    If PartUse = TOP_RAIL Then
        Set MyTable = MyDatabase.OpenRecordset("InvCMSashTopRail")
        If Not ErrorCondition Then
            On Error GoTo EditErrorHandler ' Enable error trapping.

            MyTable.MoveFirst
            MyTable.Index = "Size" ' Define current index.
            MyTable.Seek ">=", Length ' Seek record.
            If MyTable.NoMatch Then
                flag = False
            Else
                flag = True
                theSize = MyTable![Size]
                MyTable.Edit
                MyTable![Number Available] = MyTable![Number Available] - 1
                MyTable.Update
            End If

            MyTable.Close ' Close table.

            If flag = False Then GoTo StockErrorHandler

        End If
    Else
        If PartUse = BOTTOM_RAIL Then
            Set MyTable = MyDatabase.OpenRecordset("InvCMSashBottomRail")
            If Not ErrorCondition Then
                On Error GoTo EditErrorHandler ' Enable error trapping.

                MyTable.MoveFirst
                MyTable.Index = "Size" ' Define current index.
                MyTable.Seek ">=", Length ' Seek record.
                If MyTable.NoMatch Then
                    flag = False
                Else
                    flag = True
                    theSize = MyTable![Size]
                    MyTable.Edit
                    MyTable![Number Available] = MyTable![Number Available] - 1
                    MyTable.Update
                End If

                MyTable.Close ' Close table.

                If flag = False Then GoTo StockErrorHandler
            End If
        End If
    End If
End If

```

```

    End If
Else
    If PartUse = LEFT_STILE Then
        Set MyTable = MyDatabase.OpenRecordset("InvCMSashStile")
        If Not ErrorCondition Then
            On Error GoTo EditErrorHandler ' Enable error trapping.
            MyTable.MoveFirst
            MyTable.Index = "Size" ' Define current index.
            MyTable.Seek ">=", Length ' Seek record.
            If MyTable.NoMatch Then
                flag = False
            Else
                flag = True
                theSize = MyTable![Size]
                MyTable.Edit
                MyTable![Number Available] = MyTable![Number Available] - 1
                MyTable.Update
            End If

            MyTable.Close ' Close table.

            If flag = False Then GoTo StockErrorHandler
        End If
    Else
        If PartUse = RIGHT_STILE Then
            Set MyTable = MyDatabase.OpenRecordset("InvCMSashStile")
            If Not ErrorCondition Then
                On Error GoTo EditErrorHandler ' Enable error trapping.

                MyTable.MoveFirst
                MyTable.Index = "Size" ' Define current index.
                MyTable.Seek ">=", Length ' Seek record.
                If MyTable.NoMatch Then
                    flag = False
                Else
                    flag = True
                    theSize = MyTable![Size]
                    MyTable.Edit
                    MyTable![Number Available] = MyTable![Number Available]

                    MyTable.Update
                End If

                MyTable.Close ' Close table.

                If flag = False Then GoTo StockErrorHandler
            End If
        End If
    End If
    End If
    End If
    End If

    MyDatabase.Close ' Close database.

End If

GoTo endFunction

DEErrorHandler:

```

```

        ErrorCondition = True
        MsgBox "Can't open database.", vbExclamation
        Resume Next
TableErrorHandler:
        ErrorCondition = True
        MsgBox "Can't open table.", vbExclamation
        Resume Next
EditErrorHandler:
        ErrorCondition = True
        MsgBox "Can't read from Casement Sash Inventory table.", vbExclamation
        Resume Next
StockErrorHandler:
        ErrorCondition = True
        MsgBox "No stock is available to make this part", vbExclamation
        Resume Next

```

```
endFunction:
```

```
Public Function GetThickness() As Double
```

```
    GetThickness = thickness
```

```
End Function
```

```
Public Sub Make(ByVal theID As Long)
```

```
Dim MyWorkspace As Workspace, MyDatabase As Database
Dim MyTable As Recordset
```

```
Dim ErrorCondition As Integer
Dim UpdateDb As Boolean
```

```
UpdateDb = True
```

```
On Error GoTo DBErrorHandler ' Enable error trapping.
```

```
Set MyWorkspace = Workspaces(0)
```

```
' Open database
```

```
Set MyDatabase = MyWorkspace.OpenDatabase(theDBFile)
```

```
If Not ErrorCondition Then
```

```
    On Error GoTo TableErrorHandler ' Enable error trapping.
```

```
    ' Open table.
```

```
Set MyTable = MyDatabase.OpenRecordset("ProcCMSashParts")
```

```
If Not ErrorCondition Then
```

```
    On Error GoTo EditErrorHandler ' Enable error trapping.
```

```
    'Add Part to List
```

```
MyTable.Index = "ID"
```

```
MyTable.Seek "=", theID 'Find correct record
```

```
If PartUse = TOP_RAIL Then
```

```
    MyTable![TopRail Cut Size] = Length 'Populate Record
```

```
    MyTable![TopRail Stock Size] = GetStockSize
```

```
Else
```

```
    If PartUse = BOTTOM_RAIL Then
```

```
        MyTable![BottomRail Cut Size] = Length
```

```
        MyTable![BottomRail Stock Size] = GetStockSize
```

```

Else
    If PartUse = LEFT_STYLE Then
        MyTable![LeftStile Cut Size] = Length
        MyTable![LeftStile Stock Size] = GetStockSize
    Else
        If PartUse = RIGHT_STYLE Then
            MyTable![RightStile Cut Size] = Length
            MyTable![RightStile Stock Size] = GetStockSize
        End If
    End If
End If

If UpdateDb Then MyTable.Update ' Save Changes
MyTable.Close ' Close table.

End If

MyDatabase.Close ' Close database.

End If

GoTo endFunction

DEErrorHandler:
    ErrorCondition = True
    UpdateDb = False
    MsgBox "Can't open database.", vbExclamation
    Resume Next
TableErrorHandler:
    ErrorCondition = True
    UpdateDb = False
    MsgBox "Can't open Casement Sash Parts Pulling Process table.",
vbExclamation
    Resume Next
EditErrorHandler:
    ErrorCondition = True
    UpdateDb = False
    MsgBox "Can't enter data to Casement Sash Parts Pulling Process table.",
vbExclamation
    Resume Next

endFunction:

End Sub

Public Sub SetPartUse(ByVal aPartUse As Integer)

    PartUse = aPartUse

End Sub

Public Sub SetResource(ByVal theResource As Integer)

    itsResource = theResource

End Sub

```

## B2: Polygonal Windows

```
`(Declarations)
Option Explicit
Dim Thickness As Double
Dim Length As Double
Dim itsResource As Single
Dim PartUse As Integer

Public Sub Define(ByVal aDimension As Double)
    Length = aDimension
    If PartUse = TOP_RAIL Then
        Thickness = CASEMENT_TOP_RAIL_THICKNESS
    Else
        If PartUse = BOTTOM_RAIL Then
            Thickness = CASEMENT_BOTTOM_RAIL_THICKNESS
        Else
            If PartUse = LEFT_STILE Then
                Thickness = CASEMENT_LEFT_STILE_THICKNESS
            Else
                If PartUse = RIGHT_STILE Then
                    Thickness = CASEMENT_RIGHT_STILE_THICKNESS
                End If
            End If
        End If
    End If
End Sub

Function GetStockSize()
    Dim MyWorkspace As Workspace, MyDatabase As Database
    Dim MyTable As Recordset
    Dim ErrorCondition As Integer
    Dim theSize As Double
    Dim flag As Boolean
    flag = False
    On Error GoTo DEErrorHandler ' Enable error trapping.

    Set MyWorkspace = Workspaces(0)
    ' Open database
    Set MyDatabase = MyWorkspace.OpenDatabase(theDEFfile)
    If Not ErrorCondition Then
        On Error GoTo TableErrorHandler ' Enable error trapping.

        ' Open table and find entry
        If PartUse = TOP_RAIL Then
            Set MyTable = MyDatabase.OpenRecordset("InvCMSashTopRail")
            If Not ErrorCondition Then
                On Error GoTo EditErrorHandler ' Enable error trapping.
                MyTable.MoveFirst
                MyTable.Index = "Size" ' Define current index.
                MyTable.Seek ">=", Length ' Seek record.
                If MyTable.NoMatch Then
                    flag = False
                Else
                    flag = True
                    theSize = MyTable![Size]
                End If
            End If
        End If
    End If
End Function
```

```

        MyTable.Close ' Close table.
        If flag = False Then GoTo StockErrorHandler
    End If
Else
    If PartUse = BOTTOM_RAIL Then
        Set MyTable = MyDatabase.OpenRecordset("InvCMSashBottomRail")
        If Not ErrorCondition Then
            On Error GoTo EditErrorHandler ' Enable error trapping.
            MyTable.MoveFirst
            MyTable.Index = "Size" ' Define current index.
            MyTable.Seek ">=", Length ' Seek record.
            If MyTable.NoMatch Then
                flag = False
            Else
                flag = True
                theSize = MyTable![Size]
            End If
            MyTable.Close ' Close table.
            If flag = False Then GoTo StockErrorHandler
        End If
    Else
        If PartUse = LEFT_STILE Then
            Set MyTable = MyDatabase.OpenRecordset("InvCMSashStile")
            If Not ErrorCondition Then
                On Error GoTo EditErrorHandler ' Enable error trapping.
                MyTable.MoveFirst
                MyTable.Index = "Size" ' Define current index.
                MyTable.Seek ">=", Length ' Seek record.
                If MyTable.NoMatch Then
                    flag = False
                Else
                    flag = True
                    theSize = MyTable![Size]
                End If
                MyTable.Close ' Close table.
                If flag = False Then GoTo StockErrorHandler
            End If
        Else
            If PartUse = RIGHT_STILE Then
                Set MyTable = MyDatabase.OpenRecordset("InvCMSashStile")
                If Not ErrorCondition Then
                    On Error GoTo EditErrorHandler ' Enable error trapping.
                    MyTable.MoveFirst
                    MyTable.Index = "Size" ' Define current index.
                    MyTable.Seek ">=", Length ' Seek record.
                    If MyTable.NoMatch Then
                        flag = False
                    Else
                        flag = True
                        theSize = MyTable![Size]
                    End If
                    MyTable.Close ' Close table.
                    If flag = False Then GoTo StockErrorHandler
                End If
            End If
        End If
    End If
    MyDatabase.Close ' Close database.
End If

```



```

GoTo endFunction
DBErrorHandler:
    ErrorCondition = True
    MsgBox "Can't open database.", vbExclamation
    Resume Next
TableErrorHandler:
    ErrorCondition = True
    MsgBox "Can't open table.", vbExclamation
    Resume Next
EditErrorHandler:
    ErrorCondition = True
    MsgBox "Can't read from Casement Sash Inventory table.", vbExclamation
    Resume Next
StockErrorHandler:
    ErrorCondition = True
    MsgBox "No stock is available to make this part", vbExclamation
    Resume Next
endFunction:
    GetStockSize = theSize
End Function

```

```

Public Function GetThickness() As Double
    GetThickness = Thickness
End Function

```

```

Public Sub Make(ByVal theID As Long)
    Dim MyWorkspace As Workspace, MyDatabase As Database
    Dim MyTable As Recordset
    Dim ErrorCondition As Integer
    Dim UpdateDb As Boolean
    UpdateDb = True
    On Error GoTo DBErrorHandler ' Enable error trapping.
    Set MyWorkspace = Workspaces(0)
    ' Open database
    Set MyDatabase = MyWorkspace.OpenDatabase(theDBFile)
    If Not ErrorCondition Then
        On Error GoTo TableErrorHandler ' Enable error trapping.

        ' Open table.
        Set MyTable = MyDatabase.OpenRecordset("ProcCMSashParts")
        If Not ErrorCondition Then
            On Error GoTo EditErrorHandler ' Enable error trapping.
            'Add Part to List
            MyTable.Index = "ID"
            MyTable.Seek "=", theID 'Find correct record
            If PartUse = TOP_RAIL Then
                MyTable![TopRail Cut Size] = Length 'Populate Record
                MyTable![TopRail Stock Size] = GetStockSize
            Else
                If PartUse = BOTTOM_RAIL Then
                    MyTable![BottomRail Cut Size] = Length
                    MyTable![BottomRail Stock Size] = GetStockSize
                Else
                    If PartUse = LEFT_STILE Then
                        MyTable![LeftStile Cut Size] = Length
                        MyTable![LeftStile Stock Size] = GetStockSize
                    Else
                        If PartUse = RIGHT_STILE Then

```

```

        MyTable![RightStile Cut Size] = Length
        MyTable![RightStile Stock Size] = GetStockSize
    End If
    End If
    End If
    If UpdatedDb Then MyTable.Update ' Save Changes
    MyTable.Close ' Close table.
End If
MyDatabase.Close ' Close database.
End If
GoTo endFunction
DErrorHandler:
    ErrorCondition = True
    UpdatedDb = False
    MsgBox "Can't open database.", vbExclamation
    Resume Next
TableErrorHandler:
    ErrorCondition = True
    UpdatedDb = False
    MsgBox "Can't open Casement Sash Parts Pulling Process table.",
        vbExclamation
    Resume Next
EditErrorHandler:
    ErrorCondition = True
    UpdatedDb = False
    MsgBox "Can't enter data to Casement Sash Parts Pulling Process table.",
        vbExclamation
    Resume Next
endFunction:
End Sub

```

```

Public Sub SetPartUse(ByVal aPartUse As Integer)
    PartUse = aPartUse
End Sub

```

```

Public Sub SetResource(ByVal theResource As Integer)
    itsResource = theResource
End Sub

```

### *B2.1 Polygonal Window Class*

```

\ (Declarations)
Option Explicit
Public itsFrame As New PolygonalFrame
Public itsSash As New PolygonalSash
Dim NumPoints As Integer
Dim PointIndex As Integer
Dim Points() As Double
Dim itsID As Long
Dim thePolyShapeID As Long
Dim theInteriorPrimed As Boolean
Dim theExteriorFinish As String
Dim theColorMatchNumber As Long

```

```

Dim theJambExtension As Double
Dim theDripCap As Boolean
Dim theClearBrickMoldCasing As Boolean
Dim theClearSill As Boolean

Public Sub Define(ByVal theID As Long)
    ' Instantiate Window
    ' Read Polygonal Window DB, call define methods
    Dim MyWorkspace As Workspace, MyDatabase As Database
    Dim MyTable As Recordset
    Dim ErrorCondition As Integer

    itsID = theID
    On Error GoTo DBErrorHandler ' Enable error trapping.
    Set MyWorkspace = Workspaces(0)
    ' Open database
    Set MyDatabase = MyWorkspace.OpenDatabase(theDBFile)
    If Not ErrorCondition Then
        On Error GoTo TableErrorHandler ' Enable error trapping.
        ' Open table.
        Set MyTable = MyDatabase.OpenRecordset("DefPolygonalWindow")
        If Not ErrorCondition Then
            On Error GoTo EditErrorHandler ' Enable error trapping.
            MyTable.Index = "ID"
            MyTable.Seek "=", theID
            If MyTable.NoMatch Then
                ' catch error here
            Else
                ' Read Entry
                thePolyShapeID = MyTable![PolyShapeID]
                theInteriorPrimed = MyTable![InteriorPrimed]
                theExteriorFinish = MyTable![ExteriorFinish]
                theColorMatchNumber = MyTable![ColorMatchNumber]
                theJambExtension = MyTable![JambExtension]
                theDripCap = MyTable![DripCap]
                theClearBrickMoldCasing = MyTable![ClearBrickMoldCasing]
                theClearSill = MyTable![ClearSill]
            End If
            MyTable.Close ' Close table.
        End If
        MyDatabase.Close ' Close database.
    End If
    GetVertices 'Read them from DB
    ' Define Window Parts
    itsFrame.SetNumPoints (NumPoints)
    itsFrame.DefineParts Points
    itsSash.SetNumPoints (NumPoints)
    itsSash.DefineParts Points

    GoTo endFunction
DBErrorHandler:
    ErrorCondition = True
    'UpdateDb = False
    MsgBox "Can't open database.", vbExclamation
    Resume Next
TableErrorHandler:
    ErrorCondition = True
    'UpdateDb = False
    MsgBox "Can't open Polygonal Window Definition table.", vbExclamation
    Resume Next

```

```

EditErrorHandler:
    ErrorCondition = True
    'UpdateDb = False
    MsgBox "Can't read Polygonal Window Definition table.", vbExclamation
    Resume Next
endFunction:
End Sub

```

```

Private Sub GetVertices()
    Dim MyWorkspace As Workspace, MyDatabase As Database
    Dim MyTable As Recordset
    Dim ErrorCondition As Integer
    Dim TableName As String
    Dim UpdateDb As Boolean
    Dim i As Integer
    Dim GeometryIndex, tempIndex, tempIndex2 As Long

    UpdateDb = True
    On Error GoTo DEErrorHandler ' Enable error trapping.
    Set MyWorkspace = Workspaces(0)
    ' Open database
    Set MyDatabase = MyWorkspace.OpenDatabase(theDEFfile)
    If Not ErrorCondition Then
        ' Open table.
        On Error GoTo TableErrorHandler1 ' Enable error trapping.
        TableName = "DefPolyShape"
        Set MyTable = MyDatabase.OpenRecordset(TableName)
        If Not ErrorCondition Then
            On Error GoTo FindIDErrorHandler ' Enable error trapping.
            MyTable.Index = "ID"
            MyTable.Seek "=", thePolyShapeID 'Find correct record
            If MyTable.NoMatch Then
                'Catch Error
                MyTable.Close ' Close table.
                GoTo FindIDErrorHandler
            Else
                GeometryIndex = MyTable![FirstPoint]
            End If
        End If
    End If
    If Not ErrorCondition Then
        TableName = "DefPointsLinkedList"
        Set MyTable = MyDatabase.OpenRecordset(TableName)
        If Not ErrorCondition Then
            On Error GoTo TableErrorHandler2 ' Enable error trapping.
            'Read Geometry from DefPointsLinkedList
            MyTable.Index = "ID"
            MyTable.Seek "=", GeometryIndex 'Find correct record
            i = 0
            ReDim Preserve Points(2, i + 1) As Double
            Points(0, i) = MyTable![X]
            Points(0, i) = MyTable![Y]
            GeometryIndex = MyTable![Next]
            Do While GeometryIndex <> -1
                MyTable.Seek "=", GeometryIndex 'Find correct record
                i = i + 1
                ReDim Preserve Points(2, i + 1) As Double
                Points(0, i) = MyTable![X]
                Points(1, i) = MyTable![Y]
            Loop
        End If
    End If
End Sub

```

```

        GeometryIndex = MyTable![Next]
    Loop
        NumPoints = i + 1
    End If
    MyTable.Close ' Close table.
End If
MyDatabase.Close ' Close database.

GoTo endFunction

'Catch Errors
DErrorHandler:
    ErrorCondition = True
    UpdateDb = False
    MsgBox "Can't open database.", vbExclamation
    Resume Next
FindIDErrorHandler:
    ErrorCondition = True
    UpdateDb = False
    MsgBox "Can't find the shape definition in the database.", vbExclamation
    Resume Next
TableErrorHandler1:
    ErrorCondition = True
    UpdateDb = False
    MsgBox "Can't find the shape identifier in the database.", vbExclamation
    Resume Next
TableErrorHandler2:
    ErrorCondition = True
    UpdateDb = False
    MsgBox "Can't read a polygon vertex from database.", vbExclamation
    Resume Next
endFunction:
End Sub

Public Sub Make()
    itsFrame.SetID (itsID)
    itsFrame.Make
    itsSash.SetID (itsID)
    itsSash.Make
End Sub

```

## *B2.2 Polygonal Frame Class*

```

\ (Declarations)
Option Explicit
Dim NumPoints As Integer
Dim theParts() As New PolygonalFramePart
Dim thePoints As Double
Dim theWindowID As Long

Public Sub DefineParts(ByRef Points() As Double)
    Dim x1, y1, x2, y2, x3, y3 As Double
    Dim dot, maga, magb, angleA As Double
    Dim ratio, inrads, indegs As Double
    Dim i As Integer

```

```

'Copy array to local array with 2 points repeated for calculation
ReDim itsPoints(NumPoints + 2, 2)
For i = 0 To NumPoints - 1
    itsPoints(i, 0) = Points(0, i)
    itsPoints(i, 1) = Points(1, i)
Next
itsPoints(NumPoints, 0) = Points(0, 0)
itsPoints(NumPoints, 1) = Points(1, 0)
itsPoints(NumPoints + 1, 0) = Points(0, 1)
itsPoints(NumPoints + 1, 1) = Points(1, 1)

ReDim theParts(NumPoints)

For i = 0 To NumPoints - 1
    'Define a frame part
    x1 = itsPoints(i, 0)
    y1 = itsPoints(i, 1)
    x2 = itsPoints(i + 1, 0)
    y2 = itsPoints(i + 1, 1)
    x3 = itsPoints(i + 2, 0)
    y3 = itsPoints(i + 2, 1)
    dot = (x2 - x1) * (x3 - x2) + (y2 - y1) * (y3 - y2)
    maga = Sqr((y1 - y2) ^ 2 + (x1 - x2) ^ 2)
    magb = Sqr((y3 - y2) ^ 2 + (x3 - x2) ^ 2)
    ratio = dot / maga / magb
    inrads = Atn((-ratio) / Sqr((-ratio) * ratio + 1)) + 2 * Atn(1)
    indegs = inrads * 180 / pi
    If ratio <= 0 Then
        angleA = (180 - indegs) / 2
    Else
        angleA = (180 + indegs) / 2
    End If
    theParts(i).SetLength (maga)
    theParts(i).SetAngle2 (angleA)
    If i < NumPoints - 1 Then
        theParts(i + 1).SetAngle1 (angleA)
    End If
    If i = NumPoints - 1 Then
        theParts(0).SetAngle1 (angleA)
    End If
Next
End Sub

Public Sub Make()
    Dim i As Integer
    For i = 0 To NumPoints - 1          'loop over all frame parts
        theParts(i).SetWindowID (theWindowID)
        theParts(i).Make (theWindowID) 'make it
    Next
End Sub

Public Sub SetID(ByVal anID As Long)
    theWindowID = anID
End Sub

Public Sub SetNumPoints(ByVal Pts As Integer)
    NumPoints = Pts
End Sub

```

### B2.3 Polygonal Frame Part

```
\(Declarations)
Option Explicit
Dim Angle1 As Double
Dim Angle2 As Double
Dim Length As Double
Dim theWindowID As Long

Function GetStockSize()
    Dim MyWorkspace As Workspace, MyDatabase As Database
    Dim MyTable As Recordset
    Dim ErrorCondition As Integer
    Dim theSize As Double
    Dim flag As Boolean

    flag = False
    On Error GoTo DBErrorHandler ' Enable error trapping.
    Set MyWorkspace = Workspaces(0)
    ' Open database
    Set MyDatabase = MyWorkspace.OpenDatabase(theDEFfile)
    If Not ErrorCondition Then
        On Error GoTo TableErrorHandler ' Enable error trapping.
        ' Open table and find entry
        Set MyTable = MyDatabase.OpenRecordset("InvPolyFrameParts")
        If Not ErrorCondition Then
            On Error GoTo EditErrorHandler ' Enable error trapping.
            MyTable.Index = "Size" ' Define current index.
            MyTable.Seek ">=", Length ' Seek record.
            If MyTable.NoMatch Then
                flag = False
            Else
                flag = True
                theSize = MyTable![Size]
            End If
            MyTable.Close ' Close table.
            If flag = False Then GoTo StockErrorHandler
        End If
        MyDatabase.Close ' Close database.
    End If

    GoTo endFunction
DBErrorHandler:
    ErrorCondition = True
    MsgBox "Can't open database.", vbExclamation
    Resume Next
TableErrorHandler:
    ErrorCondition = True
    MsgBox "Can't open table.", vbExclamation
    Resume Next
EditErrorHandler:
    ErrorCondition = True
    MsgBox "Can't read from Polygonal Frame Part Inventory table.",
        vbExclamation
endFunction
```

```

        Resume Next
    StockErrorHandler:
        ErrorCondition = True
        MsgBox "No stock is available to make this part", vbExclamation
        Resume Next
    endFunction:
    GetStockSize = theSize
End Function

Public Sub Make(ByVal theWindowID As Long)
    'Open Database and table...
    'Then write out theWindowID, Length, Angle1, Angle2, and StockSize
    Dim MyWorkspace As Workspace, MyDatabase As Database
    Dim MyTable As Recordset
    Dim ErrorCondition As Integer
    Dim UpdateDb As Boolean

    UpdateDb = True
    On Error GoTo DBErrorHandler ' Enable error trapping.
    Set MyWorkspace = Workspaces(0)
    ' Open database
    Set MyDatabase = MyWorkspace.OpenDatabase(theDEFfile)
    If Not ErrorCondition Then
        On Error GoTo TableErrorHandler ' Enable error trapping.
        ' Open table.
        Set MyTable = MyDatabase.OpenRecordset("ProcPolyFrameParts")
        If Not ErrorCondition Then
            On Error GoTo EditErrorHandler ' Enable error trapping.
            'Add Part to List
            MyTable.AddNew
            MyTable.WindowID = theWindowID
            MyTable.Length = Length
            MyTable.Angle1 = Angle1
            MyTable.Angle2 = Angle2
            MyTable.StockSize = GetStockSize
            If UpdateDb Then MyTable.Update ' Save Changes
            MyTable.Close ' Close table.
        End If
        MyDatabase.Close ' Close database.
    End If
    GoTo endFunction
DBErrorHandler:
    ErrorCondition = True
    UpdateDb = False
    MsgBox "Can't open database.", vbExclamation
    Resume Next
TableErrorHandler:
    ErrorCondition = True
    UpdateDb = False
    MsgBox "Can't open Polygonal Frame Parts Fabrication Process table.",
        vbExclamation
    Resume Next
EditErrorHandler:
    ErrorCondition = True
    UpdateDb = False
    MsgBox "Can't enter data to Polygonal Frame Parts Fabrication Process
        table.", vbExclamation
    Resume Next
endFunction:

```



```

End Sub

Public Sub SetAngle1(ByVal anAngle As Double)
    Angle1 = anAngle
End Sub

Public Sub SetAngle2(ByVal anAngle As Double)
    Angle2 = anAngle
End Sub

Public Sub SetLength(ByVal aLength As Double)
    Length = aLength
End Sub

Public Sub SetWindowID(anID As Long)
    theWindowID = anID
End Sub

```

#### *B2.4 Polygonal Sash Class*

```

'(Declarations)
Option Explicit
Dim AssemblyResource As Integer
Dim itsGlazingAssembly As New GlazingAssembly
Dim NumPoints As Integer
Dim theParts() As New PolygonalSashPart
Dim thePoints As Double
Dim theWindowID As Long

Public Sub DefineParts(ByRef Points() As Double)
    Dim x1, y1, x2, y2, x3, y3 As Double
    Dim dot, maga, magb, angleA As Double
    Dim ratio, inrads, indegs, offset1, offset2 As Double
    Dim i As Integer

    'Copy array to local array with 2 points repeated for calculation
    ReDim itsPoints(NumPoints + 2, 2)
    For i = 0 To NumPoints - 1
        itsPoints(i, 0) = Points(0, i)
        itsPoints(i, 1) = Points(1, i)
    Next
    itsPoints(NumPoints, 0) = Points(0, 0)
    itsPoints(NumPoints, 1) = Points(1, 0)
    itsPoints(NumPoints + 1, 0) = Points(0, 1)
    itsPoints(NumPoints + 1, 1) = Points(1, 1)

    ReDim theParts(NumPoints)

    For i = 0 To NumPoints - 1
        'Define a sash part
        x1 = itsPoints(i, 0)
        y1 = itsPoints(i, 1)

```

```

x2 = itsPoints(i + 1, 0)
y2 = itsPoints(i + 1, 1)
x3 = itsPoints(i + 2, 0)
y3 = itsPoints(i + 2, 1)
dot = (x2 - x1) * (x3 - x2) + (y2 - y1) * (y3 - y2)
maga = Sqr((y1 - y2) ^ 2 + (x1 - x2) ^ 2)
magb = Sqr((y3 - y2) ^ 2 + (x3 - x2) ^ 2)
ratio = dot / maga / magb
inrads = Atn((-ratio) / Sqr((-ratio) * ratio + 1)) + 2 * Atn(1)
indegs = inrads * 180 / pi
If ratio <= 0 Then
    angleA = (180 - indegs) / 2
Else
    angleA = (180 + indegs) / 2
End If
theParts(i).SetLength (maga)
theParts(i).SetAngle2 (angleA)
If i < NumPoints - 1 Then
    theParts(i + 1).SetAngle1 (angleA)
End If
If i = NumPoints - 1 Then
    theParts(0).SetAngle1 (angleA)
End If
Next

'Reduce Lengths based on offsets for frame (angles are ok)
For i = 0 To NumPoints - 1
    offset1 = POLYGONAL_FRAME_PART_THICKNESS / Tan(theParts(i).GetAngle1 *
        pi / 180) 'adjust maga for angle 1 offset
    offset2 = POLYGONAL_FRAME_PART_THICKNESS / Tan(theParts(i).GetAngle2 *
        pi / 180) 'adjust maga for angle 2 offset
    theParts(i).SetLength (theParts(i).GetLength - offset1 - offset2)
Next
End Sub

Public Sub Make()
    Dim i As Integer
    For i = 0 To NumPoints - 1
        theParts(i).SetWindowID (theWindowID)
        theParts(i).Make (theWindowID)
    Next
End Sub

Public Sub SetID(ByVal anID As Long)
    theWindowID = anID
End Sub

Public Sub SetNumPoints(ByVal Pts As Integer)
    NumPoints = Pts
End Sub

```

## *B2.5 Polygonal Sash Part*

```

\ (Declarations)
Option Explicit
Dim Angle1 As Double
Dim Angle2 As Double
Dim Length As Double
Dim theWindowID As Long

Public Sub SetAngle1(ByVal anAngle As Double)
    Angle1 = anAngle
End Sub

Public Sub SetAngle2(ByVal anAngle As Double)
    Angle2 = anAngle
End Sub

Public Sub SetLength(ByVal aLength As Double)
    Length = aLength
End Sub

Public Sub SetWindowID(anID As Long)
    theWindowID = anID
End Sub

Public Sub Makes(ByVal theWindowID As Long)
    'Open Database and table...
    'Then write out theWindowID, Length, Angle1, Angle2, and StockSize
    Dim MyWorkspace As Workspace, MyDatabase As Database
    Dim MyTable As Recordset
    Dim ErrorCondition As Integer
    Dim UpdateDb As Boolean

    UpdateDb = True
    On Error GoTo DBErrorHandler ' Enable error trapping.
    Set MyWorkspace = Workspaces(0)
    ' Open database
    Set MyDatabase = MyWorkspace.OpenDatabase(theDEFfile)
    If Not ErrorCondition Then
        On Error GoTo TableErrorHandler ' Enable error trapping.
        ' Open table.
        Set MyTable = MyDatabase.OpenRecordset("ProcPolySashParts")
        If Not ErrorCondition Then
            On Error GoTo EditErrorHandler ' Enable error trapping.
            'Add Part to List
            MyTable.AddNew
            MyTable.WindowID = theWindowID
            MyTable.Length = Length
            MyTable.Angle1 = Angle1
            MyTable.Angle2 = Angle2
            MyTable.StockSize = GetStockSize
            If UpdateDb Then MyTable.Update ' Save Changes
            MyTable.Close ' Close table.
        End If
        MyDatabase.Close ' Close database.
    End If
End Sub

```

```

GoTo endFunction
DBErrorHandler:
    ErrorCondition = True
    UpdateDb = False
    MsgBox "Can't open database.", vbExclamation
    Resume Next
TableErrorHandler:
    ErrorCondition = True
    UpdateDb = False
    MsgBox "Can't open Polygonal Sash Parts Fabrication Process table.",
        vbExclamation
    Resume Next
EditErrorHandler:
    ErrorCondition = True
    UpdateDb = False
    MsgBox "Can't enter data to Polygonal Sash Parts Fabrication Process
        table.", vbExclamation
    Resume Next
endFunction:
End Sub

```

## B3: Glazing Assemblies

### *B3.1 Glazing Assembly Class*

```

\ (Declarations)
Option Explicit
Dim ArgonGas As Boolean
Dim NumGlazings As Integer
Dim AssemblyResource As Integer
Dim itsInnerGlazing As New Glazing
Dim itsMiddleGlazing As New Glazing
Dim itsOuterGlazing As New Glazing
Dim NumPoints As Integer
Dim PointIndex As Integer
Dim Points() As Double

Public Sub DefineNumPoints(ByVal aNum As Double)
    NumPoints = aNum
    ReDim Points(NumPoints, 2) As Double
End Sub

Sub SetX(ByVal X As Double)
    Points(PointIndex, 0) = X
End Sub

Sub SetY(ByVal Y As Double)
    Points(PointIndex, 1) = Y
    PointIndex = PointIndex + 1
End Sub

```

```

Public Sub DefineParts(ByVal WindowID As Long)
    Dim theGlazingID As Long
    Dim MyWorkspace As Workspace, MyDatabase As Database
    Dim MyTable As Recordset
    Dim winType As Integer
    Dim ErrorCondition As Integer

    On Error GoTo DEErrorHandler ' Enable error trapping.
    Set MyWorkspace = Workspaces(0)
    ' Open database
    Set MyDatabase = MyWorkspace.OpenDatabase(theDEFfile)
    If Not ErrorCondition Then
        On Error GoTo TableErrorHandler ' Enable error trapping.
        Set MyTable = MyDatabase.OpenRecordset("Windows")
        MyTable.Index = "ID"
        MyTable.Seek "=", WindowID
        If MyTable.WindowType = "Polygonal" Then
            winType = POLYGONAL
        Else
            winType = CASEMENT
        End If

    If winType = CASEMENT Then
        ' Open table.
        Set MyTable = MyDatabase.OpenRecordset("DefCasementWindow")
        If Not ErrorCondition Then
            On Error GoTo EditErrorHandler ' Enable error trapping.
            MyTable.Index = "ID"
            MyTable.Seek "=", WindowID 'Find correct record
            If MyTable.NoMatch Then
                'Catch Error
                MyTable.Close ' Close table.
                GoTo GlazingErrorHandler
            Else
                ' Read Entry
                theGlazingID = MyTable![GlazingID]
                MyTable.Close ' Close table.
                'Read data from Glazing Table
                Set MyTable = MyDatabase.OpenRecordset("DefGlazingAssy")
                If Not ErrorCondition Then
                    On Error GoTo EditErrorHandler ' Enable error trapping.
                    MyTable.Index = "ID"
                    MyTable.Seek "=", theGlazingID 'Find correct record
                    If MyTable.NoMatch Then
                        'Catch Error
                        MyTable.Close ' Close table.
                        GoTo GlazingErrorHandler
                    Else
                        NumGlazings = MyTable![NumGlazings]
                        itsInnerGlazing.DefineTempered
                            (MyTable![InnerTempered])
                        itsInnerGlazing.DefineThickness
                            (MyTable![InnerThickness])
                        itsInnerGlazing.DefineCoating (MyTable![InnerCoating])
                        itsInnerGlazing.DefineNumPoints (NumPoints)
                        If NumGlazings > 1 Then
                            itsOuterGlazing.DefineTempered
                                (MyTable![OuterTempered])
                            itsOuterGlazing.DefineThickness
                                (MyTable![OuterThickness])

```

```

        itsOuterGlazing.DefineCoating
            (MyTable![OuterCoating])
        itsOuterGlazing.DefineNumPoints (NumPoints)
    End If
    If NumGlazings > 2 Then
        itsMiddleGlazing.DefineTempered
            (MyTable![MiddleTempered])
        itsMiddleGlazing.DefineCoating
            (MyTable![MiddleCoating])
        itsMiddleGlazing.DefineThickness
            (MyTable![MiddleThickness])
        itsMiddleGlazing.DefineNumPoints (NumPoints)
    End If
    MyTable.Close ' Close table.
End If
End If
End If
End If

Else
    ' Open table.
    Set MyTable = MyDatabase.OpenRecordset("DefPolygonalWindow")
    If Not ErrorCondition Then
        On Error GoTo EditErrorHandler ' Enable error trapping.
        MyTable.Index = "ID"
        MyTable.Seek "=", WindowID 'Find correct record
        If MyTable.NoMatch Then
            'Catch Error
            MyTable.Close ' Close table.
            GoTo GlazingErrorHandler
        Else
            ' Read Entry
            theGlazingID = MyTable![GlazingID]
            MyTable.Close ' Close table.
            'Read data from Glazing Table
            Set MyTable = MyDatabase.OpenRecordset("DefGlazingAssy")
            If Not ErrorCondition Then
                On Error GoTo EditErrorHandler ' Enable error trapping.
                MyTable.Index = "ID"
                MyTable.Seek "=", theGlazingID 'Find correct record
                If MyTable.NoMatch Then
                    'Catch Error
                    MyTable.Close ' Close table.
                    GoTo GlazingErrorHandler
                Else
                    NumGlazings = MyTable![NumGlazings]
                    itsInnerGlazing.DefineTempered
                        (MyTable![InnerTempered])
                    itsInnerGlazing.DefineThickness
                        (MyTable![InnerThickness])
                    itsInnerGlazing.DefineCoating (MyTable![InnerCoating])
                    itsInnerGlazing.DefineNumPoints (NumPoints)
                    If NumGlazings > 1 Then
                        itsOuterGlazing.DefineTempered
                            (MyTable![OuterTempered])
                        itsOuterGlazing.DefineThickness
                            (MyTable![OuterThickness])
                        itsOuterGlazing.DefineCoating
                            (MyTable![OuterCoating])
                        itsOuterGlazing.DefineNumPoints (NumPoints)
                    End If
                End If
            End If
        End If
    End If
End If

```

```

        End If
        If NumGlazings > 2 Then
            itsMiddleGlazing.DefineTempered
                (MyTable! [MiddleTempered])
            itsMiddleGlazing.DefineCoating
                (MyTable! [MiddleCoating])
            itsMiddleGlazing.DefineThickness
                (MyTable! [MiddleThickness])
            itsMiddleGlazing.DefineNumPoints (NumPoints)
        End If
        MyTable.Close ' Close table.
    End If
End If
End If
End If
End If

MyDatabase.Close ' Close database.

End If

itsInnerGlazing.DefineNumPoints (NumPoints)
itsInnerGlazing.Define Points
If NumGlazings > 1 Then
    itsOuterGlazing.DefineNumPoints (NumPoints)
    itsOuterGlazing.Define Points
End If
If NumGlazings > 2 Then
    itsMiddleGlazing.Define Points
    itsMiddleGlazing.DefineNumPoints (NumPoints)
End If

GoTo endFunction

DBErrorHandler:
    ErrorCondition = True
    MsgBox "Can't open database.", vbExclamation
    Resume Next
TableErrorHandler:
    ErrorCondition = True
    MsgBox "Can't open table containing Glazing Assembly ID.",
        vbExclamation
    Resume Next
EditErrorHandler:
    ErrorCondition = True
    MsgBox "Can't read Glazing Assembly ID from table.", vbExclamation
    Resume Next
GlazingErrorHandler:
    ErrorCondition = True
    MsgBox "Can't find Glazing Assembly ID in table", vbExclamation
    Resume Next
endFunction:
End Sub

Public Sub Make()
    itsInnerGlazing.Make

```

```

    If NumGlazings > 1 Then itsOuterGlazing.Make
    If NumGlazings > 2 Then itsMiddleGlazing.Make
End Sub

```

### B3.2 Glazing Class

```

\ (Declarations)
Option Explicit
Dim Coating As Integer
Dim thickness As Double
Dim Tempered As Boolean
Dim NumPoints As Integer
Dim AssemblyResource As Integer
Dim itsPoints() As Double

Sub ChooseAssemblyResource()
    Dim x1, y1, x2, y2, x3, y3 As Double
    Dim dot, maga, magb, angleA As Double
    Dim ratio, inrads, indegs As Double
    Dim smallestAngle As Double
    Dim left, right, top, bottom As Double
    Dim bbMin, bbMax As Double
    Dim i As Integer
    Dim theGlazingResourceSpec As GlazingResourceSpec

    ' find resource with required capabilities
    ' 96 and 4 inch bounding box (send bbMin and bbMax)
    ' Angles > 15 deg (send smallestAngle)
    ' < 3/16 thick (send thickness)

    'Find Bounding Box
    For i = 0 To NumPoints - 1
        If itsPoints(i, 0) < left Then left = itsPoints(i, 0)
        If itsPoints(i, 0) > right Then right = itsPoints(i, 0)
        If itsPoints(i, 1) < bottom Then bottom = itsPoints(i, 1)
        If itsPoints(i, 1) > top Then top = itsPoints(i, 1)
    Next
    bbMin = right - left
    If bbMin > top - bottom Then bbMin = top - bottom
    bbMax = right - left
    If bbMax < top - bottom Then bbMax = top - bottom

    'Find Smallest Angles
    For i = 0 To NumPoints - 1
        x1 = itsPoints(i, 0)
        y1 = itsPoints(i, 1)
        x2 = itsPoints(i + 1, 0)
        y2 = itsPoints(i + 1, 1)
        x3 = itsPoints(i + 2, 0)
        y3 = itsPoints(i + 2, 1)
        dot = (x2 - x1) * (x3 - x2) + (y2 - y1) * (y3 - y2)
        maga = Sqr((y1 - y2) ^ 2 + (x1 - x2) ^ 2)
        magb = Sqr((y3 - y2) ^ 2 + (x3 - x2) ^ 2)
        ratio = dot / maga / magb
        inrads = Atn((-ratio) / Sqr((-ratio) * ratio + 1)) + 2 * Atn(1)
        indegs = inrads * 180 / pi
    Next
End Sub

```



```

    If ratio <= 0 Then
        angleA = (180 - indegs) / 2
    Else
        angleA = (180 + indegs) / 2
    End If
    If angleA < smallestAngle Then smallestAngle = angleA
Next

G_GlazingResourceSpec.bbMin = bbMin
G_GlazingResourceSpec.bbMax = bbMax
G_GlazingResourceSpec.smallestAngle = smallestAngle
G_GlazingResourceSpec.thickness = thickness

'find valid resource
If G_GlazingCNC.RequestUtilization() = True Then
    AssemblyResource = CNC
Else
    If G_GlazingManual.RequestUtilization() = True Then
        AssemblyResource = MANUAL
    Else
        AssemblyResource = NO_RESOURCE
    End If
End If
End Sub

Public Sub Define(ByRef thePoints() As Double)
    Dim i As Integer
    ReDim itsPoints(NumPoints + 2, 2)
    For i = 0 To NumPoints - 1
        itsPoints(i, 0) = thePoints(i, 0)
        itsPoints(i, 1) = thePoints(i, 1)
    Next
    itsPoints(NumPoints, 0) = thePoints(0, 0)
    itsPoints(NumPoints, 1) = thePoints(0, 1)
    itsPoints(NumPoints + 1, 0) = thePoints(1, 0)
    itsPoints(NumPoints + 1, 1) = thePoints(1, 1)
    ChooseAssemblyResource
End Sub

Public Sub DefineCoating(ByVal aCoating As Integer)
    Coating = aCoating
End Sub

Public Sub DefineNumPoints(ByVal Number As Integer)
    NumPoints = Number
End Sub

Public Sub DefineTempered(ByVal aTempered As Boolean)
    Tempered = aTempered
End Sub

Public Sub DefineThickness(ByVal aThickness As Single)
    thickness = aThickness
End Sub

```

```

Public Sub Make()
    Dim MyWorkspace As Workspace, MyDatabase As Database
    Dim MyTable As Recordset
    Dim ErrorCondition As Integer
    Dim TableName As String
    Dim UpdateDb As Boolean
    Dim i As Integer
    Dim GeometryIndex, tempIndex, tempIndex2 As Long

    UpdateDb = True
    On Error GoTo DBErrorHandler ' Enable error trapping.
    Set MyWorkspace = Workspaces(0)
    ' Open database
    Set MyDatabase = MyWorkspace.OpenDatabase(theDBFile)
    If Not ErrorCondition Then
        On Error GoTo TableErrorHandler ' Enable error trapping.
        TableName = "DefPointsLinkedList"
        Set MyTable = MyDatabase.OpenRecordset(TableName)
        If Not ErrorCondition Then
            On Error GoTo EditErrorHandler1 ' Enable error trapping.
            'Add Geometry to DefPointsLinkedList
            'Add first points and get start index for polygon
            MyTable.AddNew
            GeometryIndex = MyTable![ID]
            tempIndex = MyTable![ID]
            MyTable![X] = itsPoints(0, 0)
            MyTable![Y] = itsPoints(0, 1)
            MyTable![Next] = -1
            If UpdateDb Then MyTable.Update
            'Add remaining points
            For i = 1 To NumPoints - 1
                'add the point
                MyTable.AddNew
                MyTable![X] = itsPoints(i, 0)
                MyTable![Y] = itsPoints(i, 1)
                MyTable![Next] = -1
                tempIndex2 = MyTable![ID]
                If UpdateDb Then MyTable.Update
                'fix the previous point
                MyTable.Index = "ID"
                MyTable.Seek "=", tempIndex
                MyTable.Edit
                MyTable![Next] = tempIndex2
                If UpdateDb Then MyTable.Update
                tempIndex = tempIndex2
            Next
        End If
        'If UpdateDb Then MyTable.Update
        MyTable.Close ' Close table.

        If AssemblyResource = CNC Then
            TableName = "ProcGlazingCNC"
        Else
            TableName = "ProcGlazingManual"
        End If
        Set MyTable = MyDatabase.OpenRecordset(TableName)
        If Not ErrorCondition Then
            On Error GoTo EditErrorHandler2 ' Enable error trapping.
            'Add Part to ProcGlazingsCNC List

```

```

        MyTable.AddNew
        MyTable![Coating] = Coating
        MyTable![thickness] = thickness
        MyTable![Tempered] = Tempered
        MyTable![Glazing Geometry] = GeometryIndex
    End If
    If UpdateDb Then MyTable.Update
    MyTable.Close ' Close table.
End If
MyDatabase.Close ' Close database.

GoTo endFunction

'Catch Errors
DBErrorHandler:
    ErrorCondition = True
    UpdateDb = False
    MsgBox "Can't open database.", vbExclamation
    Resume Next
TableErrorHandler:
    ErrorCondition = True
    UpdateDb = False
    MsgBox "Can't open Glazing Assembly Process table.", vbExclamation
    Resume Next
EditErrorHandler1:
    ErrorCondition = True
    UpdateDb = False
    MsgBox "Can't add record to Glazing Geometry table.", vbExclamation
    Resume Next
EditErrorHandler2:
    ErrorCondition = True
    UpdateDb = False
    MsgBox "Can't add record to Glazing Assembly Process table.", vbExclamation
    Resume Next
endFunction:

End Sub

```

## B4: Production Resources

### *B4.1 GlazingCNC Class*

```

' (Declarations)
Option Explicit
Dim bbMin As Double
Dim bbMax As Double
Dim smallestAngle As Double
Dim maxThickness As Double

Public Function RequestUtilization()
    If bbMin <= G_GlazingResourceSpec.bbMin And
        bbMax >= G_GlazingResourceSpec.bbMax And
        smallestAngle >= G_GlazingResourceSpec.smallestAngle And
        maxThickness >= G_GlazingResourceSpec.thickness Then

```

```

        RequestUtilization = True
    Else
        RequestUtilization = False
    End If
End Function

```

#### *B4.2 GlazingManual Class*

```

\ (Declarations)
Option Explicit

Public Function RequestUtilization()
    'No Restrictions
    RequestUtilization = True
End Function

```

#### *B4.3 Class*

```

\ (Declarations)
Option Explicit

Public Function RequestUtilization()
    'No Restrictions
    RequestUtilization = True
End Function

```

### **B5: Constants, Globals, and Other**

```

\ (Declarations)
Option Explicit

Public Const CASEMENT As Integer = 100
Public Const POLYGONAL As Integer = 101

Public Const ROUGH_INCREMENT As Single = 0.5
Public Const CNC As Integer = 1
Public Const MANUAL As Integer = 2
Public Const NO_RESOURCE As Integer = 3

Public Const CM_RO_WIDTH_2_FS_WIDTH = -1#
Public Const CM_MO_WIDTH_2_FS_WIDTH = -3.625
Public Const CM_GS_WIDTH_2_FS_WIDTH = 4.4375
Public Const CM_RO_HEIGHT_2_FS_HEIGHT = -0.5
Public Const CM_MO_HEIGHT_2_FS_HEIGHT = -1.8125
Public Const CM_GS_HEIGHT_2_FS_HEIGHT = 6.1875

Public Const CASEMENT_FRAME_CNC_MIN As Double = 4
Public Const CASEMENT_FRAME_CNC_MAX As Double = 96
Public Const CASEMENT_SASH_CNC_MIN As Double = 4
Public Const CASEMENT_SASH_CNC_MAX As Double = 96
Public Const POLYGONAL_FRAME_CNC_MIN As Double = 3
Public Const POLYGONAL_FRAME_CNC_MAX As Double = 48

```

```

'Part Sizes
Public Const CASEMENT_HEADER_THICKNESS = 3.8
Public Const CASEMENT_SILL_THICKNESS = 2.1
Public Const CASEMENT_LEFT_JAMB_THICKNESS = 1.3
Public Const CASEMENT_RIGHT_JAMB_THICKNESS = 3.8
Public Const CASEMENT_TOP_RAIL_THICKNESS = 2.1
Public Const CASEMENT_BOTTOM_RAIL_THICKNESS = 1.3
Public Const CASEMENT_LEFT_STILE_THICKNESS = 3.8
Public Const CASEMENT_RIGHT_STILE_THICKNESS = 2.1
Public Const POLYGONAL_FRAME_PART_THICKNESS = 1.7
Public Const POLYGONAL_SILL_THICKNESS = 1.6

Public Const theDBFile As String = "C:\research\vb_app\CWDS.MDB"

'PartUse Constants
Public Const TOP_RAIL As Integer = 20
Public Const BOTTOM_RAIL As Integer = 21
Public Const LEFT_STILE As Integer = 22
Public Const RIGHT_STILE As Integer = 23
Public Const HEADER As Integer = 24
Public Const SILL As Integer = 25
Public Const LEFT_JAMB As Integer = 26
Public Const RIGHT_JAMB As Integer = 27

'Glazing Coatings
Public Const NO_COATING As Integer = 0
Public Const SOUTHERN_LOW_E As Integer = 1
Public Const NORTHERN_LOW_E As Integer = 2

Public Const pi As Double = 3.14159265385979

Public GlazingDefined As Boolean
Public G_ArgonGas As Boolean
Public G_NumGlazings As Integer
Public G_InnerCoating As Integer
Public G_OuterCoating As Integer
Public G_MiddleCoating As Integer
Public G_InnerThickness As Single
Public G_OuterThickness As Single
Public G_MiddleThickness As Single
Public G_InnerTempered As Boolean
Public G_OuterTempered As Boolean
Public G_MiddleTempered As Boolean

' Production Resources
Public theCasementFrameCNC As New CasementFrameCNC
Public theCasementSashCNC As New CasementSashCNC
Public thePolygonalFrameCNC As New PolygonalFrameCNC
Public thePolygonalSashCNC As New PolygonalSashCNC

Type Point ' Create user-defined type.
    X As Single
    Y As Single
End Type

Type PolyPart ' Create user-defined type.
    Length As Double

```

```

    Angle1 As Double
    Angle2 As Double
End Type

Type Polygon ' Create user-defined type.
    NumPoints As Integer
    ShapeType As String
    Vertices() As Point
    Part() As PolyPart
End Type

Public G_Polygon As Polygon

Type GlazingResourceSpec ' Create user-defined type.
    bbMin As Double
    bbMax As Double
    smallestAngle As Double
    thickness As Double
End Type

Public G_GlazingResourceSpec As GlazingResourceSpec

Public G_GlazingCNC As New GlazingCNC
Public G_GlazingManual As New GlazingCNC

Sub Main()
    Load MainForm
    MainForm.Visible = True
End Sub

Sub DoCasement(ByVal WindowID As Long)
    ' Instantiate Casement Window Object
    Dim theCasement As New CasementWindow
    theCasement.Define (WindowID)

    ' Call Make Method to generate process plan
    theCasement.Make
End Sub

Sub DoPolygonal(ByVal WindowID As Long)
    ' Instantiate Polygonal Window Object
    Dim thePolygonal As New PolygonalWindow
    thePolygonal.Define (WindowID)

    ' Call Make Method to generate process plan
    thePolygonal.Make
End Sub

```