

MODIFICATION OF A BIOSAND FILTER
IN THE NORTHERN REGION OF GHANA

By

Izumi Kikkawa

B. S. Chemical Engineering
The University of Tokyo, 2007

SUBMITTED TO THE DEPARTMENT OF CIVIL AND ENVIRONMENTAL
ENGINEERING IN PARTIAL FULFILLMENT OF THE REQUIREMENTS FOR THE
DEGREE OF

MASTER OF ENGINEERING IN CIVIL AND ENVIRONMENTAL ENGINEERING
AT THE
MASSACHUSETTS INSTITUTE OF TECHNOLOGY

JUNE 2008

© 2008 Izumi Kikkawa. All Rights Reserved

The author hereby grants to MIT permission to reproduce
and to distribute publicly paper and electronic
copies of this thesis document in whole or in part.

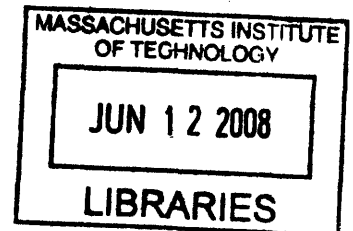

ARCHIVES

Signature of Author: _____

Izumi Kikkawa
Department of Civil and Environmental Engineering
May 22, 2008

Certified by: _____

Susan E. Murcott
Lecturer of Civil and Environmental Engineering
Thesis Supervisor

Accepted by: _____

Daniele Veneziano
Chairman, Departmental Committee of Graduate Students

MODIFICATION OF A BIOSAND FILTER IN THE NORTHERN REGION OF GHANA

By

Izumi Kikkawa

Submitted to the Department of Civil and Environmental Engineering
on May 22, 2008 in Partial Fulfillment of the Requirements for the
Degree of Master of Engineering in Civil and Environmental Engineering

ABSTRACT

Four local plastic design (LPD) BSFs were constructed in Northern Region, Ghana, to test and evaluate an experimental modification of the LPD BSF for treatment of highly turbid water. Modifications of the LPD BSFs were made in order to provide an additional “biolayer,” the core layer of a BSF where most removal and degradation of pathogens occur. This adjustment was carried out by providing an additional diffuser basin, with an additional layer of sand in it. Along with two unmodified LPD BSFs, two modified LPD BSFs were built: one with an additional 5-cm sand layer, one with an additional 10-cm sand layer. Filter ripening was confirmed through an increase in turbidity removal after 13 days. All four LPD BSFs removed turbidity by an average of 92-95 % after Day 13, with average effluents of 10 - 16 TU (14 – 22 NTU). The modified BSFs showed slightly higher removal of turbidity after 27 days of operation. This could be an indication that the modified BSFs potentially withstand greater operational variation, or that the modified BSFs require less frequent cleaning. The average total coliform removal after 11 days was 87 % with an average effluent concentration of 430 cfu/100 ml from an influent concentration of 15,000 cfu/100 ml.

Concurrently, 30 BSFs (HydrAid™ BioSand Water Filter) that were installed in a local village were tested for flow rate, turbidity, and *E. coli*/total coliform bacteria. These HydrAid BSFs showed an average turbidity removal of 87 %, and an average total coliform removal of 95 %, with average effluents of 2.9 NTU for turbidity and 710 cfu/100 ml of total coliform. Further research, such as testing the BSFs with influent of higher turbidity, which is typical in Northern Region, Ghana, is recommended to evaluate the effectiveness of the HydrAid BSF.

Thesis Supervisor: Susan E. Murcott

Title: Lecturer of Civil and Environmental Engineering

Contents

1	Introduction	12
1.1	Water Supply in Developing Countries.....	12
1.2	Biosand Filter Overview.....	13
1.3	Objectives.....	15
1.4	Drinking Water in the Northern Region of Ghana.....	16
1.4.1	Geography of Ghana	16
1.4.2	Drinking Water.....	17
1.4.3	Dugouts.....	19
1.5	Summary	20
2	Slow Sand Filtration.....	22
2.1	Slow Sand Filtration Overview.....	22
2.2	Mechanisms of Filtration	24
2.3	Design and Operation of Slow Sand Filtration.....	28
2.3.1	Filter Medium.....	28
2.3.2	Flow Rate	28
2.3.3	Ripening and Cleaning	29
2.3.4	Dissolved Oxygen	30
2.3.5	Continuous Operation	30
3	Water Treatment Efficiency	31
3.1	Water Quality	31
3.2	Criteria for Safe Water	31
3.2.1	Total Coliform.....	31
3.2.2	Escherichia coli (E. coli)	32
3.2.3	Turbidity	32
3.3	Analytical Methods.....	32
3.3.1	Turbidity	32
3.3.2	Microbial Testing	33
4	BioSand Filter.....	36
4.1	Development of the Biosand Filter.....	36

4.2	Design and Comparison of Biosand Filters.....	37
4.2.1	Concrete Rectangular BSF.....	37
4.2.2	Plastic Davnor BSF.....	39
4.2.3	Comparison of the Concrete Rectangular BSF and the Plastic Davnor BSF .	41
5	Local Plastic Design Biosand Filter and its Modification.....	43
5.1	Field Site Description	43
5.2	Local Plastic Design Biosand Filter.....	45
5.3	Local Plastic Design Biosand Filter Construction Method.....	46
5.4	Research Approach for Modification	49
5.5	Design Modification.....	50
5.6	Operation and Evaluation Methods.....	53
5.7	Results.....	55
5.7.1	Flow Rate	55
5.7.2	Turbidity.....	57
5.7.3	Microbial Testing.....	62
5.8	Discussion.....	64
5.9	Conclusions	65
6	HydrAid Biosand Filters.....	67
6.1	Research Approach.....	67
6.2	HydrAid BSF Design.....	68
6.3	Field Site Description	69
6.4	Sampling and Evaluation Methods.....	71
6.5	Results.....	73
6.5.1	Flow Rate	73
6.5.2	Turbidity.....	73
6.5.3	Microbial Testing.....	77
6.5.4	Average Turbidity and Microbial Testing Results.....	80
6.6	Discussion.....	82
6.7	Conclusions	84
7	Comparison of Local Plastic Design BSFs, HydrAid BSFs and Other BSF Designs.....	85
8	Summary and Conclusions	87

9	References	88
Appendix A	Summary of Peer-Reviewed and Grey Literature on BSFs	93
Appendix B	Raw Data.....	96
	Local Plastic Design BSFs (Microbial Testing).....	96
	Local Plastic Design BSFs (Flow Rate and Turbidity).....	97
	HydrAid BSFs (Microbial Testing)	98
	HydrAid BSFs (Turbidity)	100
	HydrAid BSFs (Flow Rate)	101
Appendix C	Construction and Installation Manual of LPD BSF.....	102
Appendix D	Correlation Analysis of Turbidity Values Measured in Nephelometric Turbidity Units (NTU) and Turbidity Units (TU)	128

List of Tables

Table 1-1 Field Test Results of BSFs	15
Table 2-1 Typical Treatment Performance of Conventional Slow Sand Filtration	22
Table 2-2 Design Criteria of Slow Sand Filtration	24
Table 4-1 Comparison of the Concrete BSF and the Plastic Davnor BSF Design	42
Table 5-1 Equipment for BSF Construction	47
Table 5-2 Average Flow Rate of Standard and Modified BSFs	55
Table 5-3 Average Turbidity of the Ghanasco Dam and the Water Filtered Through the LPD BSFs (Days 7 to 11).....	60
Table 5-4 Average Turbidity of the Ghanasco Dam and the Water Filtered Through the LPD BSFs (TU Converted to NTU; Days 13 to 46).....	60
Table 5-5 Average Turbidity Percent Removal after Day 13.....	62
Table 5-6 Hydrogen Sulfide Bacteria Presence/Absence Test Results.....	63
Table 7-1 Comparison of Four BSF Designs.....	85
Table 7-2 Comparison of LPD BSFs and HydrAid BSFs.....	86

List of Figures

Figure 1-1 Countries that have Biosand Filters Installed	13
Figure 1-2 Map of Ghana.....	16
Figure 1-3 Regional Poverty Profile, Ghana	17
Figure 1-4 Water and Sanitation Coverage in Ghana.....	18
Figure 1-5 Diarrhea and Mortality for Children in Ghana	18
Figure 1-6 Types of Water Sources Used in Households in Northern Ghana	19
Figure 1-7 Dugout in Ghana.....	20
Figure 2-1 Schematic of a Slow Sand Filter	23
Figure 2-2 Relation between Grain Size and Pore Size.....	25
Figure 3-1 Picture of Hach 2100P Turbidimeter (left) and DelAgua Turbidity Tube (right)	33
Figure 3-2 3M Petrifilms (left), Red and Blue Colonies with Bubbles (right)	34
Figure 3-3 Membrane Filtration Method: Millipore portable membrane filtration assembly unit (left) and a sample showing results (right)	35
Figure 3-4 H ₂ S Bacteria Presence/Absence Test	35
Figure 4-1 Diagram of a Biosand Filter.....	36
Figure 4-2 Concrete Rectangular BSF; Picture of Concrete BSFs in Haiti (left), Picture of Inner and Outer Mold (middle), Dimension of the Walls of the Inner Mold (right).....	38
Figure 4-3 Dimensions and Media Specifications of the Concrete Rectangular BSF	39
Figure 4-4 Picture of the Plastic Davnor BSF.....	40
Figure 4-5 Dimensions and Media Specifications of the Plastic Davnor BSF	41
Figure 5-1 Map of Tamale and the Nearby Village/Dugouts.....	44
Figure 5-2 Dimensions and Media Specifications of the LPD BSF.....	45
Figure 5-3 Picture of a LPD BSF and Diffuser Basin.....	46
Figure 5-4 Dimensions and Media Specification of a Modified LPD BSF.....	51

Figure 5-5 Modified and Unmodified LPD BSFs	52
Figure 5-6 Pictures of the Constructed LPD BSFs.....	53
Figure 5-7 Flow Rate of Unmodified (BSF A & A') and Modified BSFs (BSF B & C).....	56
Figure 5-8 Turbidity of the Ghanasco Dam.....	58
Figure 5-9 Turbidity of the Ghanasco Dam and Effluents of the LPD BSFs (Day 7 – Day 46; TU units converted to NTU)	59
Figure 5-10 Turbidity Removal of the LPD BSFs.....	61
Figure 5-11 Log ₁₀ Removal of Total Coliform for Day 7 through Day 11'	63
Figure 6-1 HydrAid BSF Provided by International Aid (left) and the Author Taking Water Samples in Kpanvo (right)	68
Figure 6-2 Dimensions of HydrAid BSF (Sand size specification unknown)	69
Figure 6-3 Villagers Using Foot Pump at the Kpanvo Dam	70
Figure 6-4 House in Kpanvo Village.....	70
Figure 6-5 Water Samples from Kpanvo Dam (right) and Ghanasco Dam (left) in Whirlpak® Bags.....	71
Figure 6-6 Picture of the Author Collecting a Water Sample from a HydrAid BSF	72
Figure 6-7 Histogram of Flow Rates for HydrAid BSFs	73
Figure 6-8 Turbidity Values of Influent/Effluent of the HydrAid BSFs.....	75
Figure 6-9 Turbidity Percent Removal of HydrAid BSFs	75
Figure 6-10 Histogram of Turbidity of Influent for HydrAid BSFs.....	76
Figure 6-11 Histogram of Turbidity of Effluent for HydrAid BSFs.....	76
Figure 6-12 Histogram of Turbidity Removal for HydrAid BSFs.....	77
Figure 6-13 Total Coliform Concentration of Influent/Effluent of HydrAid BSFs.....	78
Figure 6-14 Total Coliform Percent Removal for HydrAid BSFs in Kpanvo.....	78
Figure 6-15 Histogram of Total Coliform Log ₁₀ Removal for HydrAid BSFs.....	79
Figure 6-16 Average Turbidity Values at Different Stages of Treatment	80

Figure 6-17 Average *E. coli* Concentrations at Different Stages of Treatment..... 81

Figure 6-18 Average Total Coliform Concentrations at Different Stages of Treatment.... 82

Abbreviations

BSF	Biosand Filter
CAWST	Center for Affordable Water and Sanitation Technology
CFU	Colony Forming Units
<i>E. coli</i>	<i>Escherichia coli</i>
HWTS	household water treatment and safe storage
LPD BSF	local plastic design Biosand Filter
MDG	Millennium Development Goals
NGO	non-governmental organization
NTU	Nephelometric Turbidity Units
TU	Turbidity Units

1 Introduction

1.1 *Water Supply in Developing Countries*

Lack of access to safe drinking water is a pressing issue worldwide. Having access to safe drinking water, which is mostly taken for granted in developed countries, is essential for living a healthy life. The lack of access to safe water is the cause of water-related diseases and hinders work and development by weakening people's bodies and spirits and also by robbing time, especially from women and children who typically are the ones that collect water and suffer the consequences of contaminated water the most.

According to the United Nations, more than one billion people lack access to safe drinking water and approximately 1.8 million children are dying from diarrheal diseases every year (WHO/UNICEF, 2004). In the Millennium Development Goals (MDGs), the United Nations have set Target 10 (Goal 7) to "Halve, by 2015, the proportion of people without sustainable access to safe drinking water and basic sanitation" (United Nations, 2005). While the meta-analysis conducted by Esrey et al. (1985) has emphasized the importance of hygiene and sanitation for diarrheal illness reduction, Fewtrell and Colford (2002) have shown the importance of water quality. Thus, national governments, local and international non-governmental organizations (NGOs), private enterprises, communities, and individuals have been trying to increase access to safe water and sanitation.

For water supply, the United Nations has reported good progress towards meeting the MDGs (WHO/UNICEF, 2004). However, it has also been recognized that there are serious gaps between the results in rural and urban areas. Among the population without access to an improved source of drinking water, 84 % live in rural areas (WHO/UNICEF, 2006). Lack of safe drinking water in rural areas is more profound since water distribution systems cannot be easily and cost-effectively extended. Therefore, greater effort is required to provide water to the poor and those living in the rural areas.

In the past decade, household water treatment and safe storage (HWTS) has been gaining in recognition as an effective way to provide clean water to the developing countries, especially in rural areas (Sobsey, 2002). It is also a good solution to any household seeking an additional barrier of safe water protection. Different types of HWTS systems have been developed, including technologies based on disinfection, coagulation, filtration, and other water treatment processes. Among the many household filters that have been developed, this research focuses on biosand filters (BSFs).

1.2 Biosand Filter Overview

Approximately 270,000 BSFs have been successfully installed in 25 countries reaching more than 2.5 million people (Nichols, 2007). These countries are Brazil, Cambodia, Dominican Republic, Ecuador, El Salvador, Ethiopia, Ghana, Guatemala, Haiti, Honduras, India, Indonesia, Kenya, Lao PDR, Madagascar, Mexico, Mozambique, Nepal, Nicaragua, Nigeria, Pakistan, Peru, Tanzania, Uganda, Vietnam (Figure 1-1). This filter employs a treatment method called slow sand filtration and is designed to be operated intermittently at a household level.

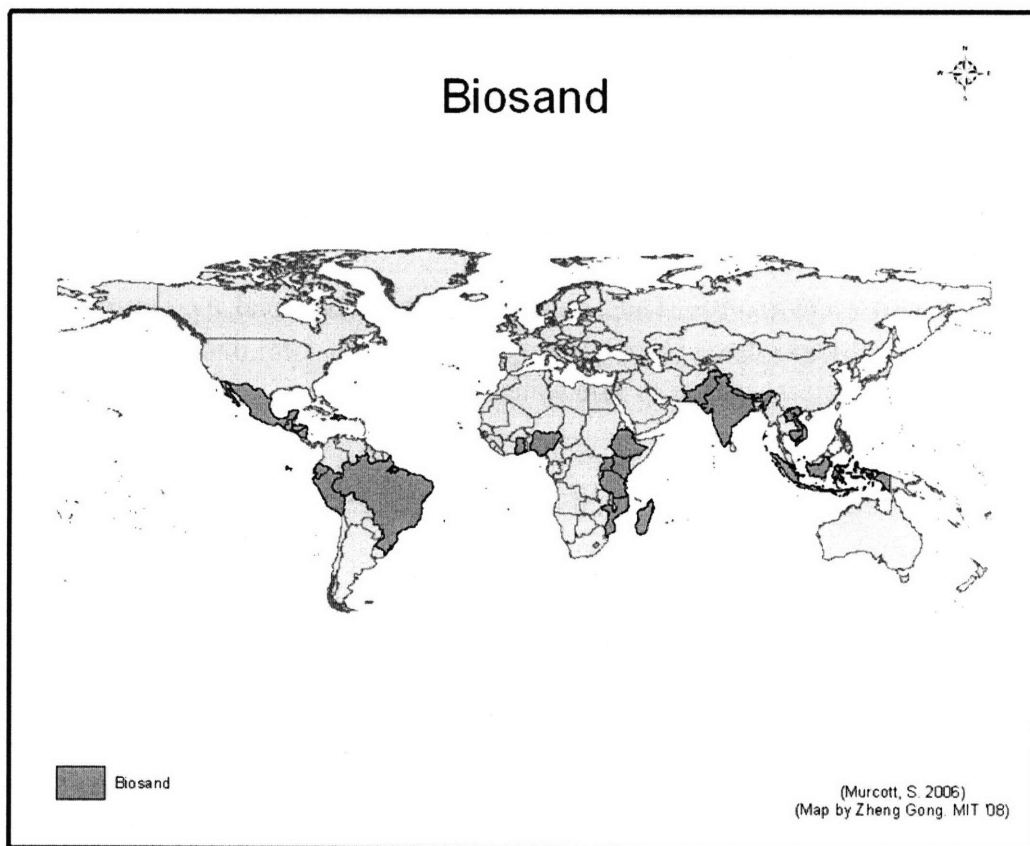

Figure 1-1 Countries that have Biosand Filters Installed

The BSF effectively removes giardia cysts, cryptosporidia oocysts, water-borne parasites, bacteria, viruses, iron (and iron bacteria), manganese, sulphur smell and other obnoxious odors, color, poor taste, and small particles (silt, clay and organic materials) from source waters (Lee, 2001). For physical quality, Buzunis has reported filtrate quality of less than 1NTU in laboratory studies (Buzunis, 1995). Laboratory studies have shown that the BSF is

capable of removing more than 5 log₁₀ units of *Giardia* and 99.98 % for *Cryptosporidium* (Palmateer et al., 1999). Other laboratory tests have shown reduction of 99.5 % of bacteria, once the biolayer has ripened (Lee, 2001).

In addition to the laboratory studies, there have also been a significant number of field tests carried out on the BSF. Results from field tests have been summarized by Earwaker (2006) and are shown in Table 1-1. Peer-reviewed and grey literatures on BSF performance in laboratory and field sites have also been summarized by Stauber (2007), and are shown in Appendix A. It must be noted that, while there have been many results showing the effectiveness of the treatment that the BSF provides, the results are affected by raw water quality, as well as by aspects of the BSF itself such as the filter ripening and operating conditions.

However, the efficacy of the BSF treatment under conditions of highly turbid influent water is largely unknown. Center for Affordable Water and Sanitation Technology (CAWST) recommends that the turbidity of the influent water should not exceed 50 NTU (CAWST, 2008), since the operation with highly turbid influent water will clog the filter, thus compromising performance and requiring more maintenance. This is the same value of turbidity limitation for slow sand filtration treatment (Schulz & Okun, 1984). Surface water in developing countries can easily exceed this limit. To take one extreme example, some of the dugouts in Northern Ghana show turbidity values as high as 1000-2000 TU (1350 – 2700 NTU) (Foran, 2007), with average turbidities of 248 NTU and 690 TU (930 NTU) for the dry and rainy season, respectively (Foran, 2007; Johnson, 2007). Extending the BSFs' abilities to treat highly turbid water would enable provision of this household drinking water treatment to many areas that only have highly turbid water.

Table 1-1 Field Test Results of BSFs

Tested by, Place, Year	Time since installation	Average faecal coliform removal rate (%)
Dr Manz, Nicaragua, 1993	21 days	97
	2 months	96.4
Agua de Saude, Brazil, 1998	2 weeks	98.64
Samaritan's Purse, Vietnam, 1998	unknown	95.8
Samaritan's Purse, East Africa, 1998	8 weeks	93.32
MedAir, Kenya, 2000	3-4 weeks	93
Nicaragua	unknown	79.9 (64.4-95)
GOSA, Guatemala, 2001	14 days	99.61
FBS, Guatemala/El Salvador, 2002	unknown	83.1
Samaritan's Purse, 6 countries, 2002	unknown	Honduras 100 %
		Nicaragua 99%
		Mozambique 98 %
		Kenya 94 %
		Cambodia 83 %
		Vietnam 81 %
		(Average 93 %)
MedAir, Kenya, 2003	2.5-4	80.7 % producing < 10 CFU
Duke, Haiti, 2005	2.5 (average)	98.5
Dejachew, Ethiopia, 2002	2.5	90
Samaritan's Purse, Ethiopia, 2005	2.5	97.3

(Source: Earwaker, 2006)

1.3 Objectives

The objectives of this research is to

- Construct a local plastic design (LPD) BSF as a control unit in the treatment of highly turbid water in Northern Region, Ghana
- Design and construct a modified LPD BSF that would potentially treat highly turbid water more effectively in Northern Region, Ghana
- Pilot test and evaluate the LPD BSF and the modified LPD BSF in Northern Region, Ghana using a local surface water source, and give recommendations for further improvement
- Evaluate the performance of HydrAid BSFs that were concurrently installed in a local village in Northern Region, Ghana

1.4 Drinking Water in the Northern Region of Ghana

1.4.1 Geography of Ghana

The Republic of Ghana is located in West Africa (Figure 1-2). It is bordered by Togo, Côte d'Ivoire, Burkina Faso, and the Gulf of Guinea. The total area is approximately 240,000 km², and the population is 23.3 million. The percentage of population living in rural areas is 64 %, while 36% lives in the urban areas (CIA, 2008). Although English is the official language, 79 languages are spoken in Ghana (Gordon, 2005).

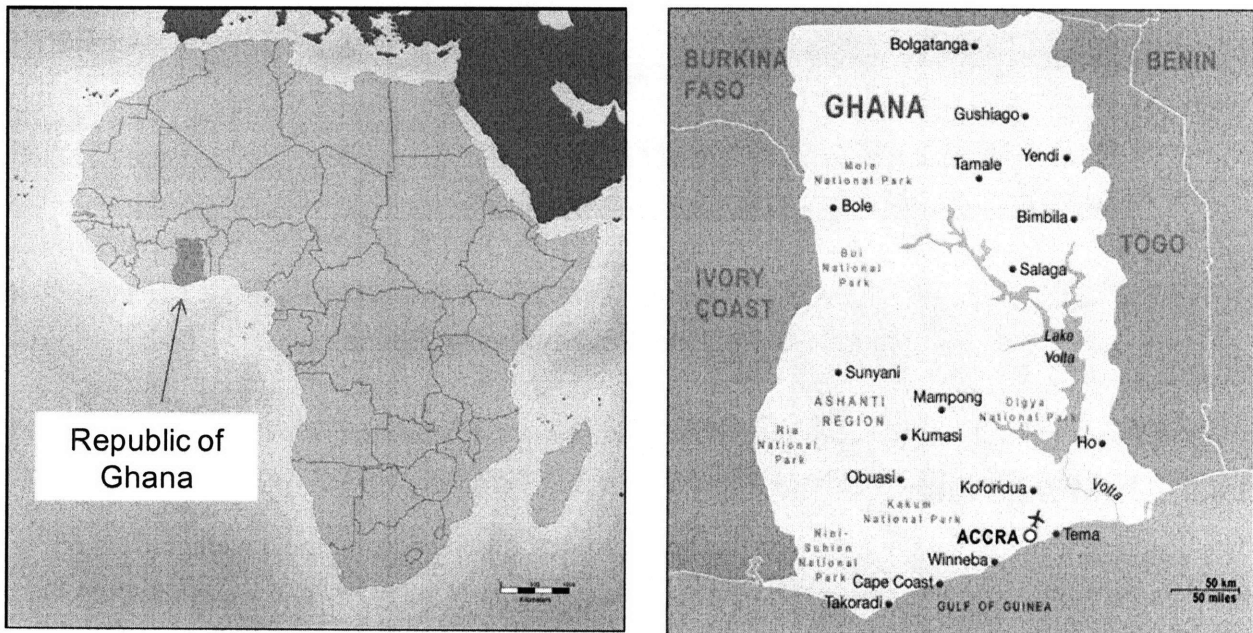

Figure 1-2 Map of Ghana

(Source: <http://www.valdosta.edu/~clmaxwell/africa%20map.jpg>,
http://www.wordtravels.com/images/map/Ghana_map.jpg)

The major diseases prevalent in Ghana are malaria, diarrhea, yellow fever, schistosomiasis (bilharzias), typhoid, and hepatitis A (CIA, 2008). It is also one of the few countries that still suffer from guinea worm incidences, together with Sudan, Mali, and Nigeria. The major cause of diarrheal disease is lack of safe and sufficient drinking water, and adequate hygiene and sanitation.

The climate in southern Ghana is tropical; warm and comparatively dry along the southeast coast and hot and humid in the southwest. The climate in northern Ghana is savannah: hot and dry. In the north, the rainy season is May to October, and the rest is the dry season (BBC, 2006).

Ghana is divided into 10 regions (Figure 1-5). As shown in Figure 1-3, poverty is highest in the regions in the northern sector, comprised of the Upper West, Upper East, and the Northern regions.

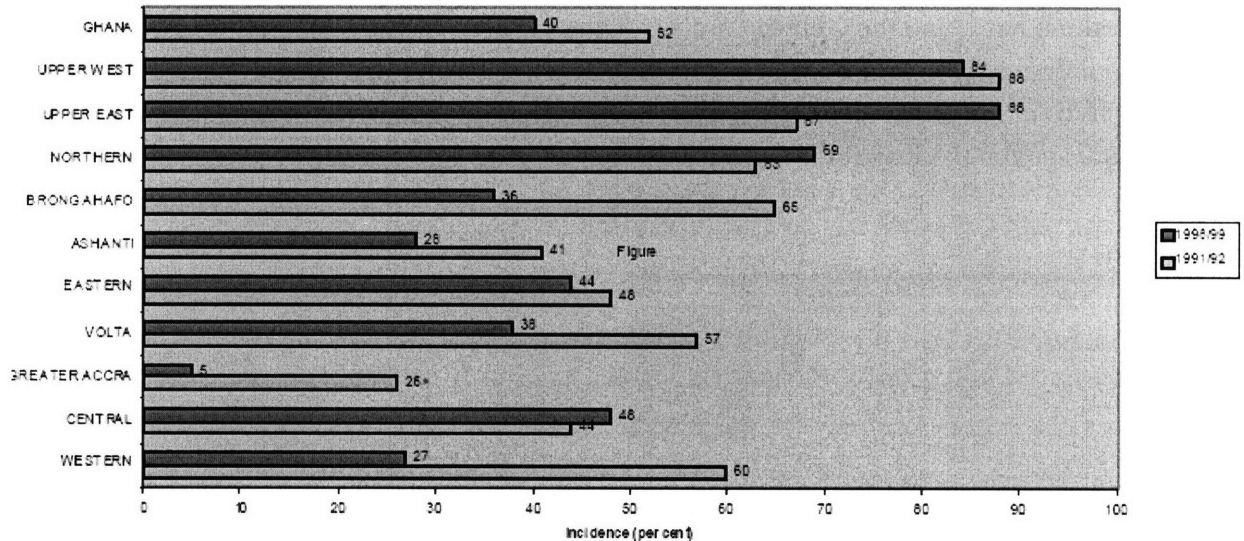
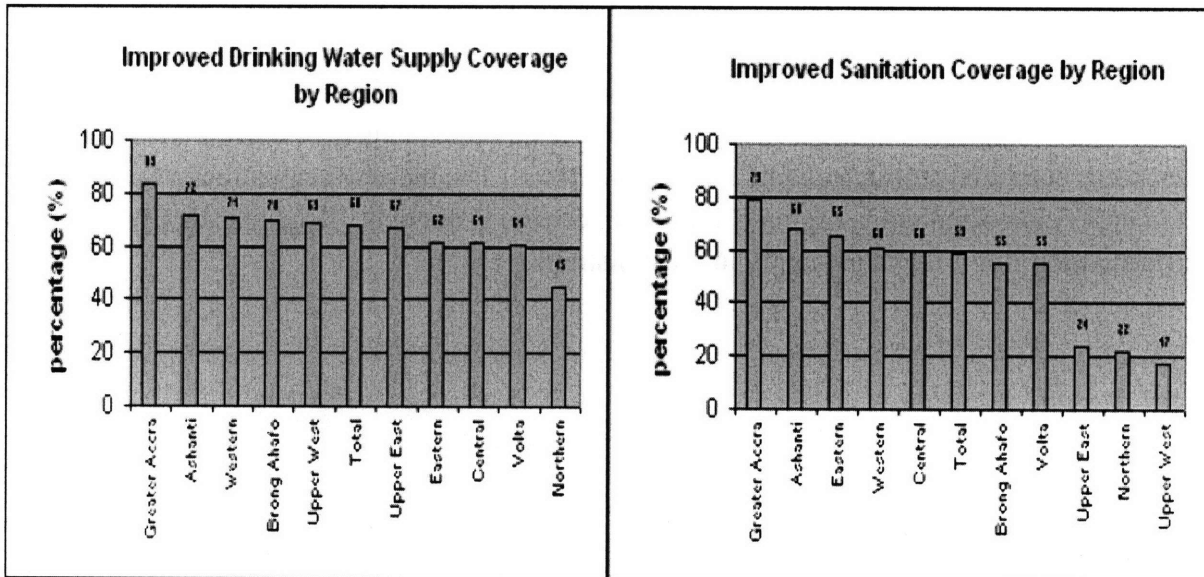

Figure 1-3 Regional Poverty Profile, Ghana

1.4.2 Drinking Water

The drinking water coverage in Ghana has been progressing, increasing the coverage from 54 % to 79 % between 1990 and 2002 (WHO/UNICEF, 2004). However, 50 % of the population in the Northern Region currently lacks access to improved water sources. Moreover, according to the survey conducted in 2003 by the Ghana Statistical Service, “More than 90 per cent of households are within 30 minutes of their source of drinking water.”

Figure 1-4 illustrates the water and sanitation coverage in Ghana. Figure 1-5 shows the mortality and diarrhea incidences in children by region. In both figures, we can see differences between the southern and northern parts of the country. The supply and quality of water and sanitation remains poor especially in the Northern sector.



Source: Ghana Statistical Service, 2003 DHS

Figure 1-4 Water and Sanitation Coverage in Ghana

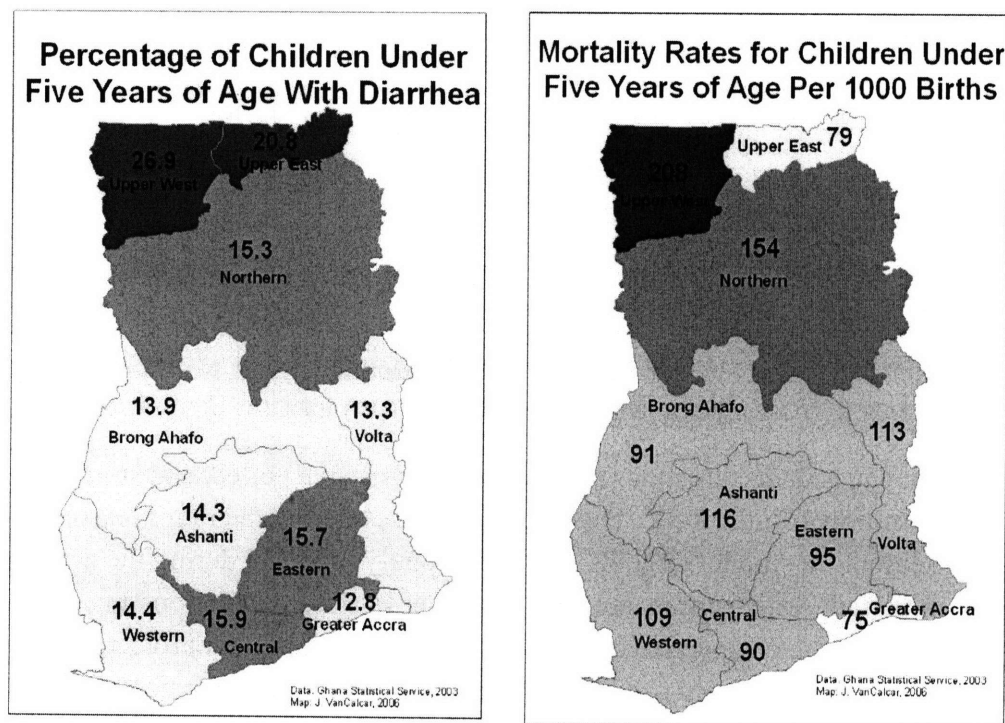

Figure 1-5 Diarrhea and Mortality for Children in Ghana

1.4.3 Dugouts

Figure 1-6 shows the types of water sources that are used in the Northern Region of Ghana. There are nine categories shown in the legend: pipe inside the home, pipe outside the home, tanker, well, borehole, spring or rain water, stream, dugout, and other. The main water source in Savelugu-Nanton and Tolon-Kumbungu region (Figure 1-6, center) is dugouts. Dugouts are also a significant contributor to water supply in most districts.

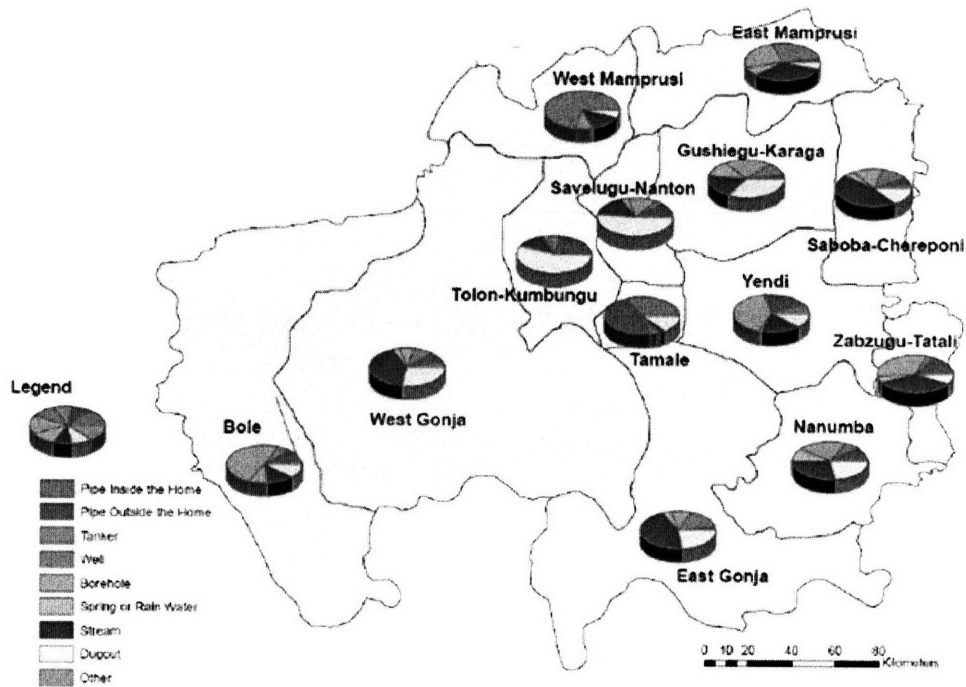

Figure 1-6 Types of Water Sources Used in Households in Northern Ghana (Map by J. VanCalcar, MIT, 2007. Data from Ghana Statistical Services, 2003)

Dugouts, also known as dams, are man-made lakes or ponds that collect and store rainwater and intermittent stream flow (Figure 1-7). The water level rises during the rainy season and declines during the dry season. In smaller dugouts, the water totally dries out during the dry season. While it is an important water source that supplies water to a big population, dugouts are also very problematic from the perspective of water quality. Since it is an unprotected source, the water is contaminated by pathogens and therefore the water requires treatment before drinking. Dugouts are also breeding areas for the anopheles mosquitoes that transport malaria, and for the water flea that is the guinea worm vector. Moreover, due to the dry and clayish soil, the water is highly turbid.

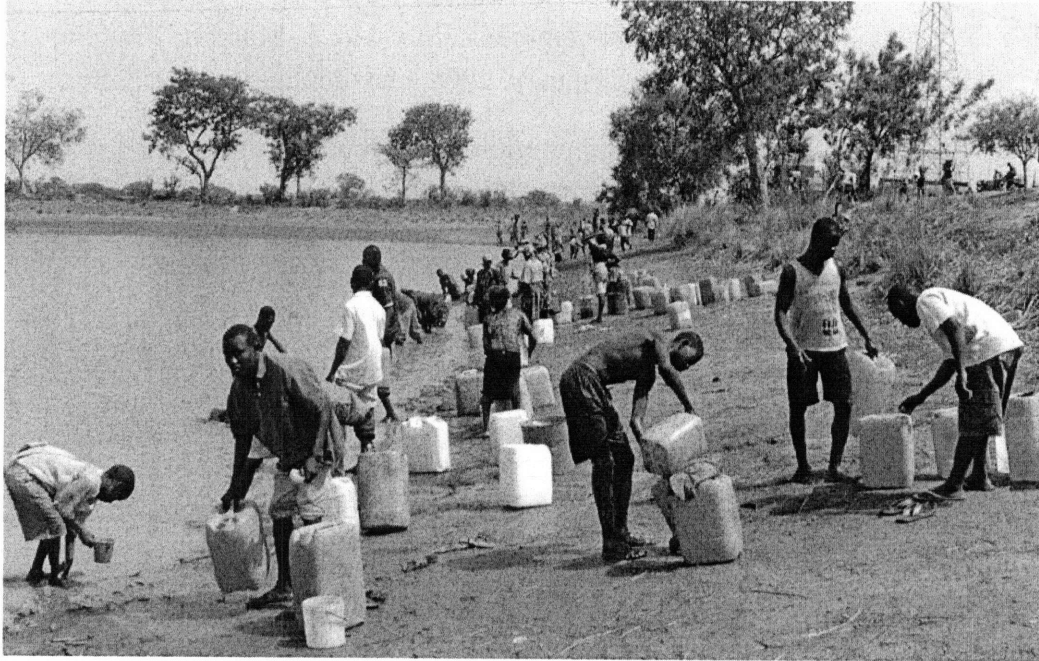

Figure 1-7 Dugout in Ghana

1.5 Summary

This research was conducted in order to provide better water treatment solutions in Northern Region, Ghana. Our research group was based in Tamale (Figure 1-2), the district capital of the Northern Region. While our team has focused on various aspects of household and community scale treatment of highly turbid water from dugouts and other unimproved sources, the research described in this thesis focused on biosand filtration.

There were two aspects to this research. The first and main part was to design, construct, and evaluate local plastic design BSFs (LPD BSFs) and modified LPD BSFs that would potentially treat highly turbid water. These BSFs were constructed by a dugout called the “Ghanasco Dam,” by the author with substantial and invaluable assistance from local Peace Corps volunteers in Ghana: Carl Allen, Kim Weaver, and Mike Dreyfuss. All construction materials used were obtained locally.

The second part of this research was to evaluate HydrAid™ BioSand Filters that had been installed during December, 2007. These HydrAid BSFs were provided by the NGO, International Aid, and were installed in a village called Kpanvo, likewise with assistance from the Peace Corps volunteer, Carl Allen. Apparently unbeknownst to International Aid, this same village was also one in which the NGO, Pure Home Water had sold *Kosim* Filters in May, 2007. Indeed, some households had both *Kosim* Filters and HydrAid BSFs. The HydrAid BSF is produced internationally and their full cost is \$50 - \$65, but was distributed in Kpanvo to all

households for free (J. Bodennes, personal communication with S. Murcott, 2008; International Aid, 2007). The testing was conducted in January, 2008, one month after installation.

Chapter 2 discusses slow sand filtration and provides background to the mechanisms of filtration that is essential to understand the BSF. Chapter 3 discusses water quality for drinking water, and analytical methods to evaluate water quality. In Chapter 4, the BSF is discussed, including a comparison of two BSF models that are well distributed. The experiments of the local plastic design (LPD) BSF is presented in Chapter 5, and the evaluation of the HydrAid BSFs is discussed in Chapter 6. The two designs, the LPD BSF and HydrAid BSF, are compared in Chapter 7.

2 Slow Sand Filtration

2.1 Slow Sand Filtration Overview

This section gives an overview of slow sand filtration in order to provide essential background for the discussions of the BSFs.

Slow sand filtration (SSF) is a treatment method for water, developed in the 19th century. While there have been strong movements in the developed countries to adopt more rapid and high-filtration techniques, the simplicity and effectiveness of SSF still makes it the chosen method for water treatment in many cities in the developed world and is definitely a good option in developing countries where land is cheap (Huisman & Wood 1974). Typical treatment performance of conventional SSF summarized by Collins is shown in Table 2-1 (Lee, 2001).

Table 2-1 Typical Treatment Performance of Conventional Slow Sand Filtration

<i>Parameters</i>	<i>Values</i>
Turbidity	<1.0 NTU
Coliforms	1-3 log units
Enteric Viruses	2-4 log units
Giardia Cysts	2-4+ log units
Cryptosporidium Oocysts	>4 log units
Dissolved Organic Carbon	<15-25%
Biodegradable Dissolved Organic Carbon	<50%
Trihalomethane Precursors	<20-30%
Zn, Cu, Cd, Pb	>95-99%
Fe, Mn	>67%
As	<47%

(Source: Lee,2001)

While the main process in action for rapid filtration is mechanical straining, there is an additional process in action for slow sand filtration: biological degradation. Due to the significant

contribution of the biological activities within the slow sand filter, it is also called the “biological” filter.

As shown in Figure 2-1, a slow sand filter consists of:

- a) supernatant (raw) water reservoir
- b) filter bed
- c) under-drainage system
- d) weir
- e) control valves

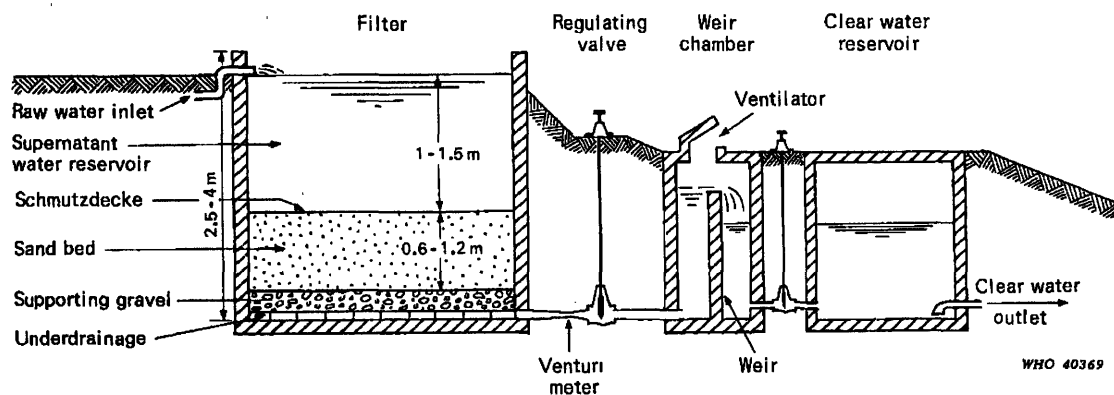

Figure 2-1 Schematic of a Slow Sand Filter

Source: (Huisman & Wood, 1974)

SSF is accomplished by slowly passing raw water through a sand bed. The whole treatment consists of several mechanisms that can be called transport, attachment, and purification mechanisms. These mechanisms interact and must be considered together when discussing slow sand filtration. The mechanisms will be discussed in more depth in Section 2.2.

The process of SSF proceeds as the water passes through the filter by gravity. First, the raw water enters the supernatant water reservoir and sits there for 3-12 hours. During this time, the heavier particles start to settle. Since the filter is gravity fed, the head of the supernatant is the driving force of filtration.

On the surface of the sand, there is a thin slimy material called the *schumutzdecke* or the filter skin. This consists of threadlike algae and various other organisms such as plankton, diatoms, protozoa, rotifers, and bacteria. Furthermore, in the upper layer of the sand bed, bacteria breed on sand surfaces and produce slimy substances called zoogloea, also known as the “biofilms.” The upper layer of the sand bed where the *schumutzdecke* and biofilms are located is called the biologically active layer, or the “biolayer.” Suspended materials that are relatively large get strained out by the sand grains and smaller particles get attached to the *schumutzdecke* and

biofilm. The active microorganisms breeding in the biolayer feed on the incoming organic matter, by entrapping, digesting and breaking them down into simple inorganic forms. Other inorganic suspended particles that enter with the raw water either get entrapped in the bed until cleaning, or leave the bed with the filtrate.

The under-drainage system supports the filter medium, and also keeps the sand from emerging with the treated water. Since there are various biological activities going on in the filter bed, it is undesirable for the water level to decrease below the filter bed. For this reason, the weir and flow control are designed in such a way as to keep the water level above the sand at all times. Furthermore, due to the biological activities in the sand bed, the filtrate would be deprived of oxygen. By driving the water over the weir, an aeration process proceeds to some extent, increasing the oxygen in the treated water. The box holding the filter bed is commonly built wholly or partly below ground.

Commonly recommended design criteria for SSF are shown in Table 2-2.

Table 2-2 Design Criteria of Slow Sand Filtration

Design Criteria	Recommended Level
Design period	10-15 years
Period of operation	24 h/d
Filtration rate in the filters	0.1-0.2 m ³ /m ² h
Filter bed area	5-200 m ² per filter, minimum of 2 units
Height of filter bed:	
initial	0.8-0.9 m
minimum	0.5-0.6 m
Specification of sand	
effective size	0.15-0.30 mm
uniformity coefficient	< 5, preferably below 3
Height of underdrains (including gravel layer)	0.3-0.5 m
Height of supernatant water	1 m
detention time:	
in supernatant wter	5-10 h
in filter bed	2.5-9 h

Source: (AWWA, 1991)

2.2 Mechanisms of Filtration

The BSF is a filter developed based on slow sand filtration. The basic mechanisms of SSF will be discussed in this section.

As discussed in the previous section, the filtration process is accomplished by passing raw water slowly through a sand bed. Raw surface water usually contains clay particles, inorganic metals and ions, and microorganisms such as plankton, diatoms, protozoa, rotifers, and bacteria. The substances in the water will go through a process of transport, attachment, and purification. As a result, organic matter is degraded to simpler inorganic forms and will pass through the filter with the effluent. Some inert materials such as metals will remain within the sand bed until cleaning.

Transport Mechanisms

The particles within the water are brought into contact with sand grains through the following processes: straining, sedimentation, inertial and centrifugal forces, and other forces of molecular scale, such as diffusion, mass attraction, and electrostatic attraction.

Straining

This is the process where the sand bed works as a sieve. Particles larger than the interstices within the sand bed will not pass through. This process occurs within the whole sand bed, and does not depend on the filtration rate. Generally, pores within a tightly packed bed of spherical grains of uniform size would prevent the passage of particles with $1/7$ (0.156) of the diameter of the grains, as shown in Figure 2-2. Therefore, if the effective grain size of the sand is $150\ \mu\text{m}$, the smallest pore size would be about $20\ \mu\text{m}$, which is much larger than colloidal particles or bacteria. However, by filtering water through the sand bed, more strained material will get attached to the sand bed, thus enhancing the straining ability but also increasing the resistance (Huisman & Wood, 1974).

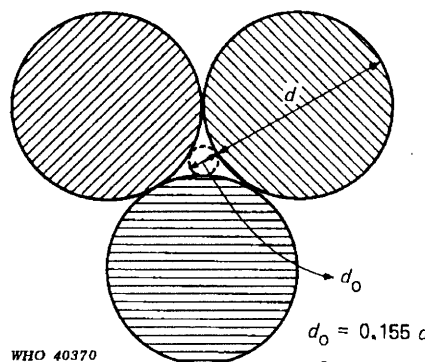

Source: Huisman & Wood,

Figure 2-2 Relation between Grain Size and Pore Size

Sedimentation

Sedimentation would occur within the pores, meaning that the upward facing surface area of all the grains would function as settling tanks. In $1\ \text{m}^3$ of sand bed with a porosity of p and grain diameter of d , there would be a surface area of,

$$\frac{6}{d}(1 - p) \quad [\text{m}^2]$$

Therefore, in 1 m³ of sand with a porosity of 38%, and an average diameter of 0.25 mm, the surface area of the sand is approximately 15000 m². Even if we

This can be derived using the ratio of the area to the volume of a sphere, $\pi d^2 / (\pi d^3 / 6) = 6 / d$

only consider the surface area that is facing upwards, and the area that is not in contact with other grains, the surface area would still be in the order of 1000 m² (Huisman & Wood 1974).

The sedimentation efficiency is determined by the surface loading rate and settling velocity of the suspended particles. If the settling velocity is equal to or greater than the surface loading rate, complete removal of the particles can be expected. The settling velocity can be estimated by Stokes law of laminar settling,

$$u = \frac{1}{18} \frac{g \Delta \rho}{\nu \rho} d_p^2$$

Where

- d_p = particle diameter
- ρ = density of water
- $\rho + \Delta \rho$ = density of suspended particle
- g = acceleration due to gravity (9.81 m/s²)
- ν = kinematic viscosity of water

At 20 °C, the kinematic viscosity of water ν is 1.01×10^{-6} m²/s. For suspended organic matter, $\Delta \rho / \rho$ is usually smaller than 0.01 (Huisman & Wood, 1974). Substituting these values give us,

$$u = 5.40 \times 10^3 d_p^2 \quad [\text{m/s}]$$

Since a normal loading rate for slow sand filtration is 0.2 m³/m²/hr, and the surface area for deposition within 1 m³ is 1000 m², the surface loading rate would be 0.2×10^{-3} m/hr. Therefore, complete removal of particles is possible when,

$$5.40 \times 10^3 d_p^2 \times 3600 \geq 0.2 \times 10^{-3}$$

$$\therefore d_p \geq 3.2 \quad [\mu\text{m}]$$

However, this calculation does not account for the effects of particle accumulation. Smaller and lighter particles would settle partially, and flocculation will increase the sedimentation efficiency.

Inertial and centrifugal forces cause particles, with higher density than water, to leave flow lines and come in contact with sand grains. *Electrostatic (Coulomb) forces* bring particles with opposite electrical charges together, at a smaller scale compared to the forces stated above. Other forces that work on a molecular scale are *diffusion* and *mass attraction*. Molecules diffuse through water by *Brownian Movement*. Diffusion occurs independently of flow rate, throughout

the whole filter, and helps particles to come in contact with grains, even when the water is not flowing. Mass attraction (*Van der Waals force*) has even less contribution to transport, but would work supplementary when particles are at very close proximity (Huisman & Wood, 1974).

Attachment Mechanisms

The *electrostatic forces*, *Van der Waals force* also contribute to attachment. Again, the *Van der Waals force* contributes only when molecules are at close proximity. The electrostatic force creates attraction between particles of opposite charges, and repels particles with the same charge. Clean quartz sand has a negative charge, and thus attracts particles with positive charge such as, crystals of carbonates, and metal ions (iron, manganese, aluminum, etc.). Colloidal particles of organic origin and bacteria normally have negative charges. Therefore, they get repelled by clean sand, yet they get attracted as the positive charges accumulate on the sand grain surfaces (Huisman & Wood, 1974).

Adhesion

The main force of attachment is adhesion due to slimy substances produced by microbiological activity. During the ripening period of a sand bed, organic material will be deposited on the sand grains, and will become the breeding ground of bacteria and other microorganisms. This would develop a slimy substance called zoogloea (also known as the biofilm), which consists of active bacteria, their wastes and dead cells, and partly assimilated organic materials. The biofilm forms a sticky gelatinous film on the sand grains, which enables the suspended particles to adhere to it. This adhesion will hold inert materials from the raw water until they are removed by cleaning. The organic materials that get attached will be biodegraded to inert inorganic forms; this is the purification process.

Purification Mechanisms

Bacterial Activity

The purification process proceeds mainly through chemical and microbiological oxidation. The bacteria derived initially from the raw water, breed within the *schmutzdecke* and biofilm by using the deposited organic matter as food. Here, metabolism (dissimilation) and assimilation proceeds as the bacteria oxidize part of the food to consume the energy for their metabolism, and use part of the energy for their growth.

The bacteria would be highly populated in the upper part of the sand layer. Therefore, the great majority of the biodegradable organic matter in the raw water would be consumed within this region. As the food gets consumed, bacteria also die due to lack of food. These dead bacteria get consumed as food by the bacteria living in the lower depths of the sand layer. Thus, the microorganisms and other organic matter are gradually broken down and converted into water, carbon dioxide, and inorganic salts such as sulfates, nitrates and phosphates, and finally leave the filter with the effluent (Huisman & Wood, 1974).

2.3 Design and Operation of Slow Sand Filtration

2.3.1 Filter Medium

The filter medium that is commonly used in SSF is fine sand.

As shown in Table 2-2, sand specifications are commonly assessed by effective size and uniformity coefficient. The *Manual of Design for Slow Sand Filtration* (AWWA, 1991) gives an overview of sand characterizations developed by Allen Hazen. The *effective size* (d_{10}) and *uniformity coefficient* (UC) are defined as,

d_{10} = the size of grain such that 10 percent by weight of the total sample is smaller [mm]

UC = the ratio of the size of grain that has 60 percent of the sample finer than itself to the size that has 10 percent finer than itself, that is, d_{60}/d_{10}

The effective size is important because (1) the grain size determines the surface area and void space within the bed, (2) the smaller grains would occupy the void space created by the larger grains, and the water would be forced between the smaller particles. The uniformity coefficient provides the ratio between larger grains and smaller grains, and determines the size of pore openings and surface area. Therefore, the grain size and uniformity would affect the required sand depth (p. 113).

Huisman and Wood (1974) recommended the effective size of sand grains for slow sand filtration to be 0.15-0.35 mm. This is based on the fact that the grain size should be small enough to produce good quality filtrate and to also keep the penetration within the top layer, so that the scrapping of the sand would be minimum. The filtrate quality would be better with smaller grain size (AWWA, 1991; Van der Hoek et al, 1996). The sand should be slightly rounded, as from a river bed (Huisman & Wood, 1974).

Di Bernardo and Rivera (1996) have evaluated the effect of sand uniformity coefficient, and concluded that with high uniformity the penetration would be deeper thus leading to longer filter runtime.

2.3.2 Flow Rate

The recommended flow rate for SSF is 0.1-0.2 $m^3/m^2/h$ (Table 2-2). Slower flow rates enable longer contact time and less shear on the biofilms. Therefore, slower flow rates would be beneficial in general. However, Paramasivam et al. have also stated that if the flow rate is too slow, enough dissolved oxygen would not be provided to the microorganisms, and therefore

make anaerobic processes to proceed. This will produce undesirable taste and odor, and the bacteriological effluent quality will decline (Buzunis, 1995)

2.3.3 Ripening and Cleaning

When a slow sand filter is first installed, the sand should be cleaned and be free of small particles such as clay. Since clean quartz sand is normally negatively charged, it does not allow the negatively charged bacteria and microorganisms to become attached to the sand particle surface. Therefore, the filter bed would initially only show effects of mechanical straining. This period until the filter develops its “biological” effects is called the ripening period. As raw water is passed through the sand bed, it will collect particles within its interstices. Positively charged particles will attach to the sand surface, and consequently allow the microorganisms to get attached. As more organic matter gets attached to the sand, the *schumutzdecke* and biofilm will start to develop, thus promoting the purification mechanism of degrading the organic matter in the raw water.

It is said that the filter ripening takes 1-3 weeks (Huisman & Wood, 1974; Buzunis, 1995), depending on the flow rate and raw water quality. Here, temperature is an important factor in the raw water quality. A 10 °C increase in water temperature would double the respiration rate of the microbes and thus account for a decrease in ripening time (Buzunis, 1995).

The biolayer, the upper region of the sand bed where the *schumutzdecke* and biofilms develop, is estimated to be 30-40 cm (Huisman & Wood, 1974), also depending on the flow rate and raw water quality. If the filter is operated with a high flow rate, it will enable the microorganisms to survive in the lower layers of the sand, thus increasing the depth of the biolayer. Another parameter that would affect the depth of the biolayer is the size of sand particles.

As the filter is operated for some period, it will collect more particles, especially in the upper layer. These particles will block the interstices and increase the head loss within the filter. When the head loss is too great, or even clogs the filter, cleaning is required. The cleaning frequency may be once in a couple of weeks or a month, depending on the operation and raw water quality. Since the majority of the suspended solids would be deposited close to the surface layer, the cleaning will be restricted to the upper layers (Huisman & Wood, 1974). For continuously operated SSFs, cleaning is operated by scrapping off the top layer of the filter bed. The layer removed is approximately 1-2 cm (Huisman & Wood, 1974).

For filtration plants, a minimum of two filter units are necessary in order to keep the plant running while one filter is being cleaned. The filter bed criterion in Table 2-2 includes an initial depth and a minimum bed depth. After continuous operation and cleaning, the filter bed would reach the minimum bed, and would then be added clean sand.

2.3.4 Dissolved Oxygen

The purification mechanism in SSF is an aerobic process. The biology existing in the filter requires a minimum of 3mg/l of dissolved oxygen (Buzunis, 1995). Without sufficient oxygen, the bacteria that perform aerobic decomposition would not survive. If anaerobic decomposition occurs, compounds such as hydrogen sulfide and ammonia would be produced, and would lead to an effluent with unfavorable taste and odor.

In continuous slow sand filtration, the oxygen is provided as dissolved oxygen in the raw water.

2.3.5 Continuous Operation

For slow sand filtration, it is typically said that intermittent operation is not good for effective filtration (Visscher et al., 1987). When operated intermittently, decline in bacteriological water quality had been seen 4-5 hours after filtration had restarted. This coincides with decline in dissolved oxygen. The worst water quality was seen from the water associated with the biological layer during the stoppage of filtration (Paramasivam et al., 1980). This is why large scale slow sand filtration requires a continuous flow: the provision of dissolved oxygen.

3 Water Treatment Efficiency

3.1 Water Quality

Provision of safe drinking water is necessary to avoid outbreaks of water-borne diseases. Pathogens in water such as, bacteria, viruses, and protozoa are the causes of millions of deaths per year. Pathogenic bacteria are common causes of gastrointestinal diseases, such as typhoid, cholera, and dysentery. It often takes several million organisms to cause sickness, but can be disinfected with proper treatment such as chlorination. Viruses, such as hepatitis A and polio, can cause sickness with much less organisms (WHO, 2006).

While microbial contamination is the causes of many water-borne diseases, many chemicals that can exist in water are hazardous to human health. The *WHO Guidelines for Drinking-Water Quality (First Addendum to 3rd Edition)* sets guideline values for numerous chemicals (2006). Physical quality such as turbidity is also important because it affects the level of treatment possible or necessary. As discussed in previous sections, the turbidity should be less than 50 NTU for slow sand filtration and less than 0.1 NTU for chlorination. Another important factor of drinking water is acceptability. People perceive the quality of water through their own senses, primarily appearance, taste and odor. Water that is aesthetically unpleasant or unacceptable can lead people to use other water sources that could be more harmful to human health.

3.2 Criteria for Safe Water

Most disease-causing water-borne pathogens are transported through faeces of animals or human beings. In order to verify the microbial safety of drinking water, microbial testing should be conducted. Since it is neither safe nor economical to test for every known water-borne pathogen, limited organisms are normally tested for as the indication of faecal contamination and treatment effectiveness. In order to assess the treatment efficiency, testing for total coliform and *Escherichia coli* (*E. coli*) is common. Another parameter of water quality that is important in this research is the turbidity. Since the goal in this research is treatment of highly turbid water, turbidity values will be closely observed.

3.2.1 Total Coliform

Total coliform bacteria is a group of aerobic and facultatively anaerobic, Gram-negative, non-spore-forming bacilli that produces an enzyme, β -galactosidase, through lactose fermentation. The total coliform group includes both faecal and environmental species, and also includes organisms that can survive and grow in water. Therefore, they are not an indicator of faecal pathogens, but can be used as an indicator of treatment effectiveness. They are tested for based on the production of acid from lactose or the production of β -galactosidase. Total coliforms should not be present in 100-ml samples after treatment (WHO, 2006).

3.2.2 Escherichia coli (E. coli)

Escherichia coli (*E. coli*) is a subset of the total coliform group that is thermotolerant: able to ferment lactose at 44 – 45 °C. *E. coli* is present in very high numbers in human and animal faeces, and is rarely found in the absence of faecal contamination. Therefore, it is commonly tested for as an index of faecal contamination for drinking water quality. Presence of *E. coli* in a 100 ml sample is evidence of recent faecal contamination (WHO, 2006).

3.2.3 Turbidity

Turbidity is a measurement of water clarity that indirectly indicates the amount of suspended matter within the water. The suspended matter such as silt, clay, algae, microorganisms, organic and inorganic particles, obstructs the transmittance of light through the water. Highly turbid water is more difficult to treat compared to clear water with low turbidity. The particulates can stimulate bacterial growth and protect microorganisms from disinfection. The turbidity concentration also limits the level of treatment. For example, disinfection requires a very low turbidity concentration of less than 0.1 NTU (WHO, 2006).

3.3 Analytical Methods

3.3.1 Turbidity

For the fieldwork in Ghana, turbidity measurements were conducted using two different instruments: HACH 2100 P turbidimeter and the DelAgua turbidity tube (Figure 3-1). The HACH 2100 P turbidimeter measures turbidity in nephelometric turbidity units (NTU) by detecting light that transmits through the water sample. To operate the HACH instrument, a 20 ml sample of water is placed in a glass vial, inserted into the detector, and the measurement is recorded.

A turbidity tube measures turbidity in turbidity units (TU), by measuring the depth of water that one can see through. The turbidity tube is a graduated clear plastic (PET) cylinder with a bulls-eye painted at the bottom of the tube. While observing the bulls-eye from the top of the tube, the water sample will be added gradually. The turbidity reading is taken when the bulls-eye is no longer visible, by noting the appropriate pre-drawn lines/values on the side of the tube.

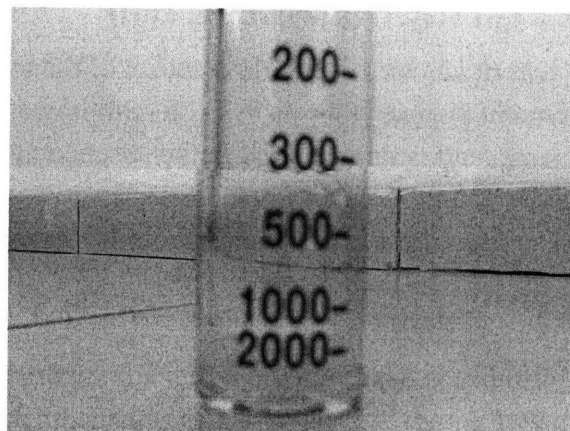

Figure 3-1 Picture of Hach 2100P Turbidimeter (left) and DelAgua Turbidity Tube (right)
Sources: (<http://www.hach.com/>) (Yazdani, 2007)

With the limit of detection of 5 TU, the turbidity tube is not as precise as a turbidimeter. However, the turbidity tube is an excellent field instrument which does not require electricity or batteries to operate and is easy to use on-site.

A correlation analysis of the two units (NTU and TU) was conducted by Losleben on samples from the same pilot test site as that of the present thesis (2008). The correlation analysis is described in Appendix D. Based on this analysis, the turbidity values can be converted between the two units with the following equation,

$$y = 0.74 x$$

where y is the turbidity value in TU, and x is the turbidity value in NTU.

3.3.2 Microbial Testing

Three different methods were used for microbial testing: 3M Petrifilm, Membrane Filtration (MF), and H₂S Bacteria Presence/Absence test. The testing method and characteristics of each method is discussed below.

For the 3M Petrifilm method, 1 ml of the sample or diluted sample is put on a Petrifilm (3M), by lifting the top film, adding the sample, and then rolling the top film down. The Petrifilms are incubated at 35 °C for 24 ± 2 hours. Then the colonies are counted for *E. coli* (blue colonies with gas) and total coliform (blue and red colonies with gas). Coliform density is reported as the number of colony forming units (CFU) per 100 ml of sample. Samples that produce more than 250 colonies are reported as “too numerous to count” (TNTC). The detection limit of the 3M Petrifilm is 1 CFU/ 1 ml of sample. Therefore, Petrifilms that show no colony forming units on the plate indicated < 100 CFU/100 ml.

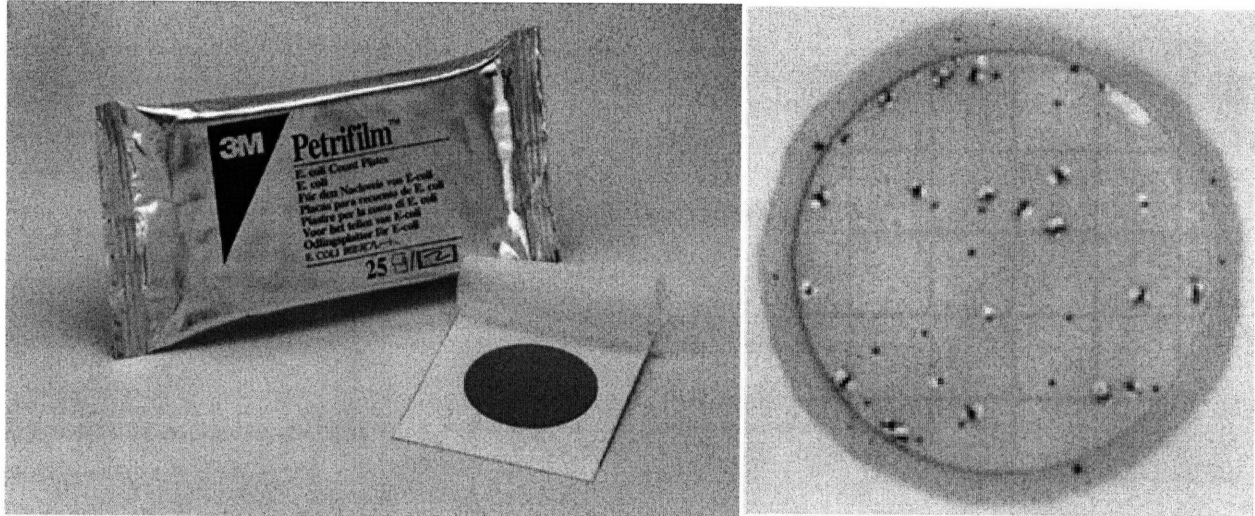

Figure 3-2 3M Petrifilms (left), Red and Blue Colonies with Bubbles (right)
(Source: http://solutions.3m.com/wps/portal/3M/en_US/Food_Industry/Home/Prod_Info/Products/Microbiology/Petrifilm_Plates/)

The membrane filtration method (11th Edition of Standard Methods) is conducted by using the Milipore portable membrane filtration assembly unit (Figure 3-3), which can be sterilized by igniting methanol and having the filter unit in contact with the formaldehyde that forms from the incomplete combustion of methanol, for 15 minutes. After sterilization, the funnel is detached, and a 47 μm pore space paper is placed on the mesh screen that sits atop the pedestal section of the filter, beneath the funnel. The funnel is reattached, and 100 ml of the sample or diluted sample is filtered by creating a vacuum below the filter. Once the sample is completely filtered, the funnel is removed and the filter is placed on a petri dish that contains an absorbent pad with mColi-Blue24 broth. The petri dish is then incubated upside down (to prevent condensate from dripping on the filtering paper) for 24 hours at 35 °C. Finally, the colonies will be counted for *E. coli* (blue colonies) and total coliform (both red and blue colonies).

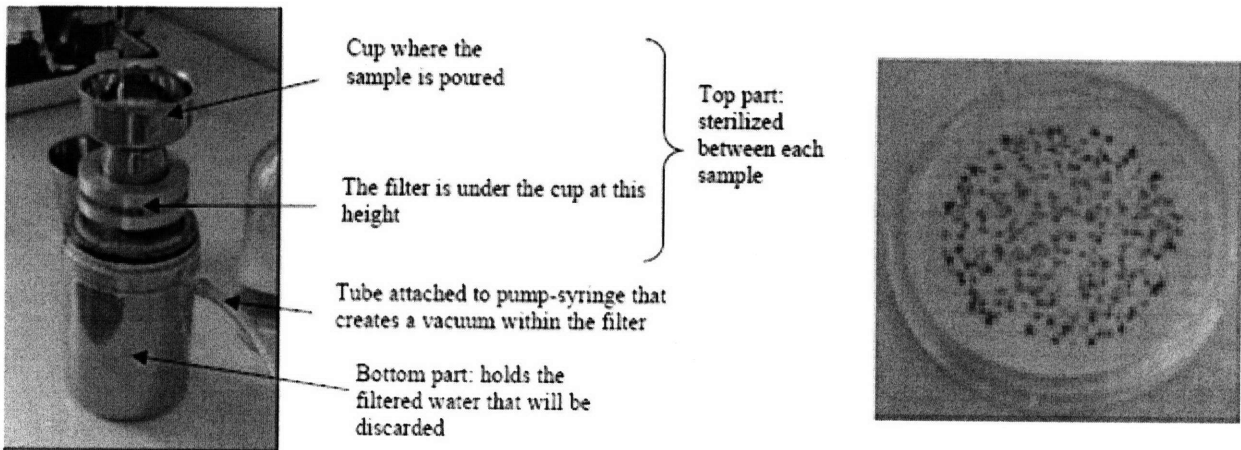

Figure 3-3 Membrane Filtration Method: Milipore portable membrane filtration assembly unit (left) and a sample showing results (right)
 (Source: Ngai & Walewijk, 2003)

While the 3M Petrifilm and Membrane Filtration method using mColi-Blue24 broth measures the *E. coli* and total coliform concentration, the H₂S Bacteria Presence/Absence test (HACH Pathoscreen) indicates the presence/absence of hydrogen sulfide producing bacteria. Thirty ml of the water sample was poured into 20 ml glass vials that contained the medium (Hach Permachem, Reagents Pathoscreen, Medium MPN pillows, Lot A4289) and was incubated for 24 hours at 35 °C. If hydrogen sulfide producing bacteria is present, the mixture of the sample and medium turns black (Figure 3-4).

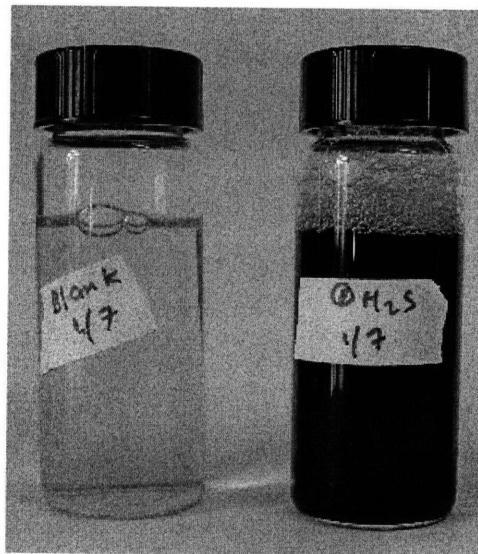

Figure 3-4 H₂S Bacteria Presence/Absence Test
 (Source: Ngai & Walewijk, 2003)

4 BioSand Filter

4.1 Development of the Biosand Filter

The BioSand Filter (BSF) was developed by Dr. David Manz, formerly of the University of Calgary. It is an application of slow sand filtration, modified to suite household water treatment that could be operated intermittently (Buzunis, 1995).

As shown in Figure 4-1 the BSF consists of a container with a lid, a diffuser plate, the filtration media, and piping. The filtration media typically consists of a layer of fine sand (< 1.0 mm), coarse sand (1-6 mm), and gravel (6-15 mm), although variations exist among organizations implementing the BSF. The coarse sand and gravel are provided to support the sand layer. Several designs have evolved through the development of the BSF, and they will be discussed in the next section.

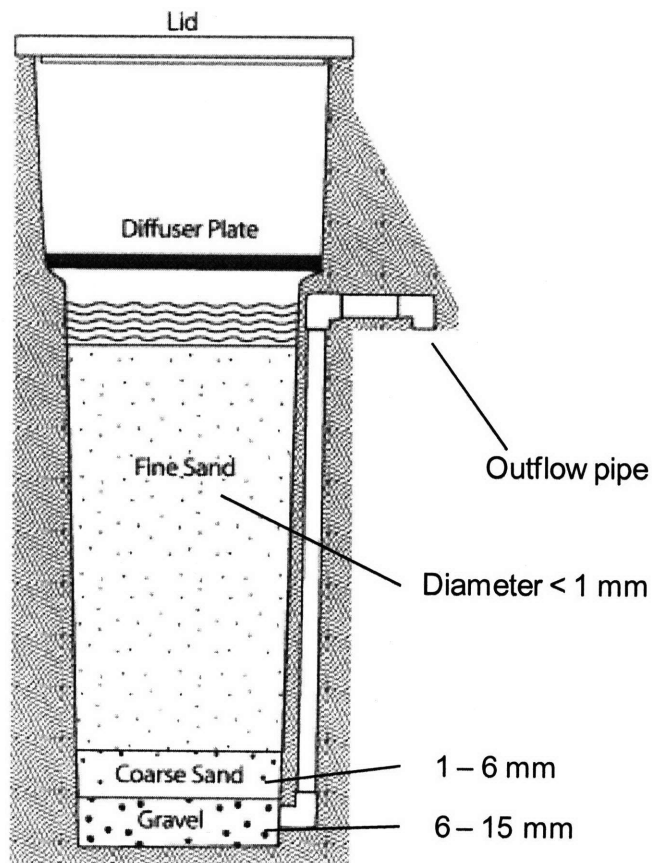

Figure 4-1 Diagram of a Biosand Filter

The general purification mechanism of the BSF is the same as SSF which has been discussed in Chapter 2. The raw water is filtered through a media of sand slowly. As the water passes through the *schumutzdecke* and the biolayer, the suspended particles get entrapped and biodegraded into simpler inorganic forms.

The difference between a continuously operated SSF and a BSF is that the BSF is a household-scale filter, and that it is operated intermittently. The intermittent operation was enabled by several modifications that were designed to maintain the biolayer active.

The key to maintaining the microbiological community alive, or even thriving, is to keep the water-sand interface undisturbed, wet and provided with sufficient oxygen and food (Buzunis, 1995). First, in order to keep the biolayer wet at all times, the piping was designed so that the water level is always above the sand layer (Figure 4-1). A diffuser plate was added so that the *schumutzdecke* would not be disturbed when pouring water in. In addition, it is instructed that the BSF should not be moved after installation.

Food is provided to the biolayer through the raw water. If the pause times are too long, there would be decline in effluent quality due to the lack of food. (Buzunis, 1995)

For SSF, the oxygen is provided by the dissolved oxygen in the raw water. However, in developing the biosand filter (an intermittently operated slow sand filter) Buzunis (1995) has indicated that sufficient oxygen would diffuse, from the air into the standing water, when the standing water depth is shallow. Through calculations of oxygen diffusion and consumption by bacteria, an effective depth of the standing water was indicated to be approximately 5 cm for a temperature of 20 °C. While the optimal standing water depth can vary between 2-10 cm according to the oxygen demand and temperature (p. 85), various models of BSFs have been designed with a standing water depth of 5 cm (Buzunis, 1995; Ngai, 2003, p.7).

Since the operating conditions and the size of the BSF is different from SSF, the depth of the biolayer is significantly different. The biolayer in a BSF is predicted to be 5-10 cm (Buzunis, 1995, p.67), while the biolayer in a SSF is 20-40 cm. This difference is due to intermittent operation of the BSF. In SSF, the continuous flow of influent enables bacteria to survive at lower depths. However, for a BSF, the bacteria cannot survive at lower depths during the pause times. While operation of the BSF, the biolayer may be expanded to a relatively lower depth, but during pause times, bacteria that can migrate will move toward the upper layer where oxygen concentration is higher. Bacteria that cannot migrate will die due to lack of oxygen.

4.2 Design and Comparison of Biosand Filters

Since the development of the BSF in the 1990s, several designs have evolved. Two designs that have widely been distributed will be discussed in this section: the Concrete Rectangular BSF and the Plastic Davnor BSF.

4.2.1 Concrete Rectangular BSF

A photo of Concrete Rectangular BSFs are shown in Figure 4-2, left. The Concrete BSF is constructed by pouring concrete into a steel mold as shown in Figure 4-2, middle. While the container (and outer mold) of the concrete is rectangular with a square base, the inner mold and

the inner chamber, where the filter media and water will be put in, is a slight trapezoid body with a square base.

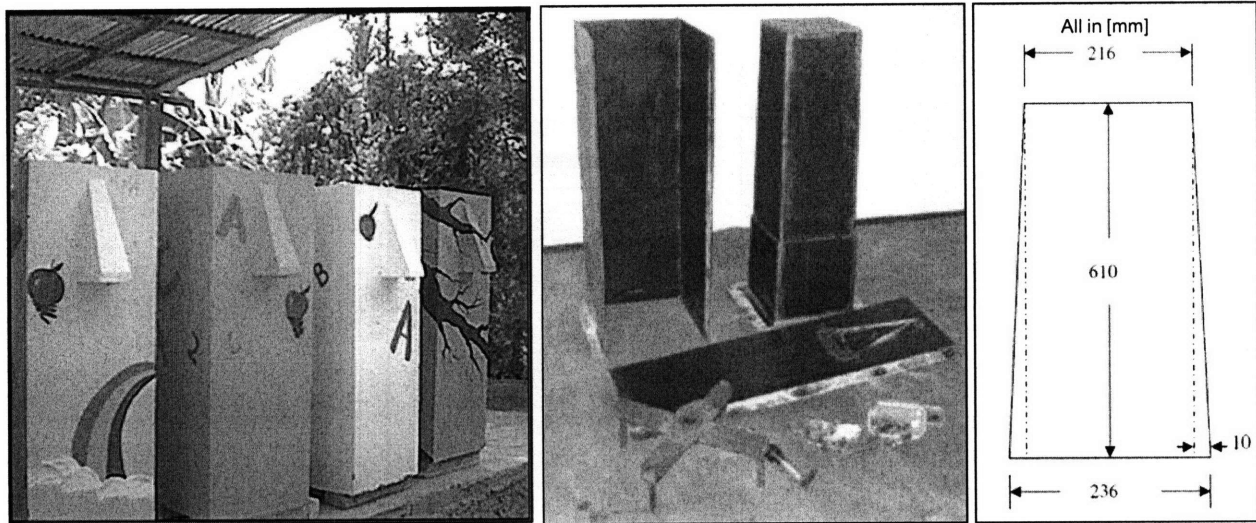

Figure 4-2 Concrete Rectangular BSF; Picture of Concrete BSFs in Haiti (left), Picture of Inner and Outer Mold (middle), Dimension of the Walls of the Inner Mold (right)

The dimensions of the Concrete rectangular BSF are shown in Figure 4-3. The outer dimensions of the Concrete Rectangular BSF are 30 cm × 30 cm (base) × 90 cm (height). The inner chamber, which is equal to the inner mold, is a trapezoid body. The dimensions of the inner mold are 21.6 cm × 21.6 cm (base) × 61 cm (height) up to above the water surface. The total height up to the lid is 90 cm. The picture on the right in Figure 4-2 shows the dimensions of the wall of the inner mold. The length of the wall (61 cm) and the height of the inner mold are approximately equal (60.9 cm) since the wall is not so slanted. From these dimensions, the volume of the inner chamber is approximately 47 L.

The minimum and maximum design flow rates for the Concrete Rectangular BSF are 12 L/hr and 36 L/hr, respectively (CAWST, 2006). The maximum water standing depth, which is the length between the sand layer surface and the container top, is 34 cm. This maximum water standing depth is a factor that would affect flow rate, since it is the maximum head possible. It will provide a wider range for the possible design flow rate. While flow rate is important since it determines the time it takes for users to obtain their filtered water, the surface loading rate and sand depth are also important factors since it indicates the contact time with sand grains, and therefore will affect the treatment efficiency (Section 2.3.2). The slower the surface loading rate is, the longer the contact time will be with sand grains. The surface loading rate of the Concrete Rectangular BSF, calculated from the average cross sectional area of the sand layer and the minimum/maximum design flow rates, is 0.23 – 0.70 m³/m²/hr (Table 4-1). The sand layer is 46 cm, as shown in Figure 4-3.

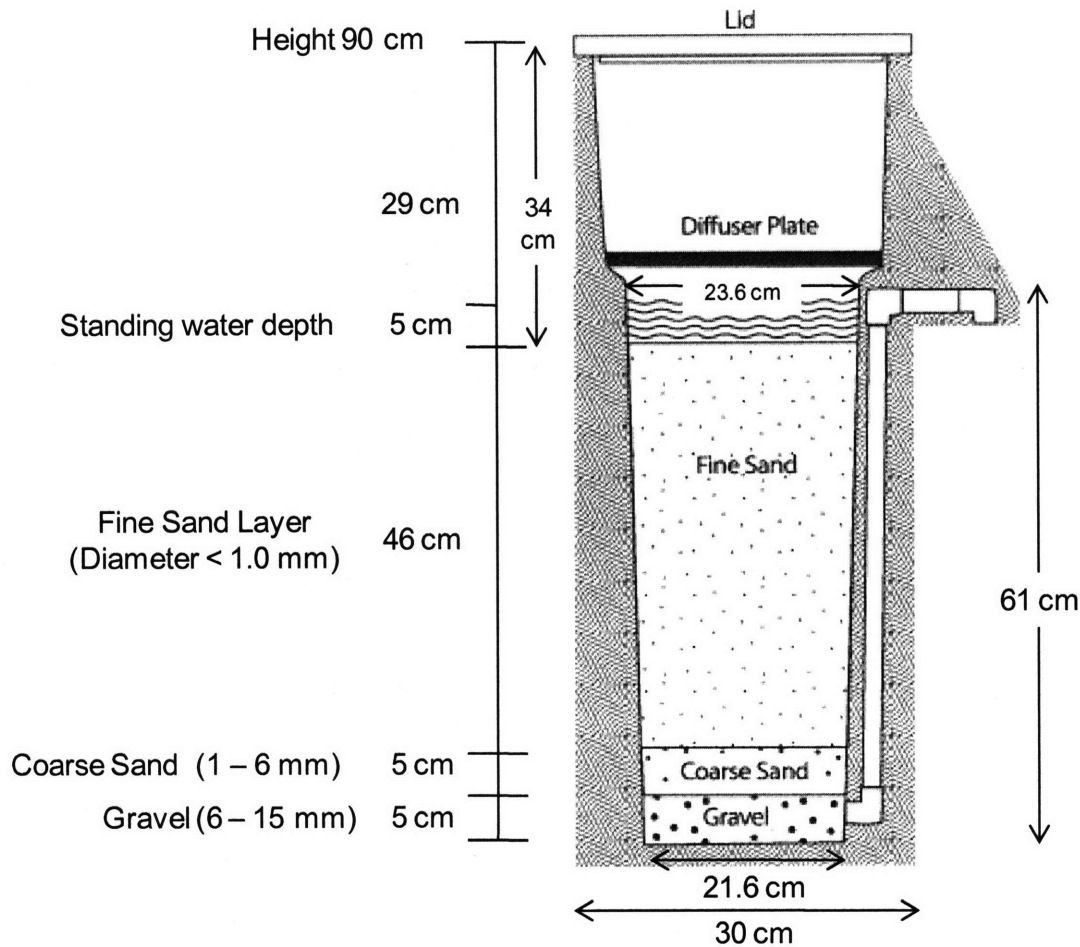

Figure 4-3 Dimensions and Media Specifications of the Concrete Rectangular BSF

4.2.2 Plastic Davnor BSF

The Plastic Davnor BSF was a design previously commercialized by Dr. Manz at the former Davnor Water Treatment Technologies, Ltd. Figure 4-4 shows a picture of a Plastic Davnor BSF. While there were several sizes of the Plastic Davnor BSF, Figure 4-5 shows the dimensions and media specifications of one type. Based on the dimensions, the container volume is calculated to be 24 L. Based on a measurement of filling water to the container of a Plastic Davnor BSF in the MIT lab, the total volume was 23.8 L. This value also includes the volume of the piping system. The design flow rate of this Plastic Davnor BSF is 20 L/hr (Pincus, 2003).

Through calculations of the average cross sectional area for the sand layer, the surface loading rate is estimated to be $0.78 \text{ m}^3/\text{m}^2/\text{hr}$ (Table 4-1). The Plastic Davnor BSF had five layers of media. The media are gravel (6-15 mm), coarse sand (3-6 mm), and three layers of fine sand: sand1 (<0.4 mm), sand2 (0.4 – 0.6 mm), sand3 (1 – 3 mm). The depth of each layer is unknown. However, the total sand layer depth (sand 1 through 3) can be estimated as $42 \pm 2 \text{ cm}$, if the support gravel and coarse sand layer is calculated to be $13 \pm 2 \text{ cm}$. The maximum water standing

depth can also be estimated as 23 cm, if we assume that the standing water is 5cm, which is a commonly selected value (Section 4.1).

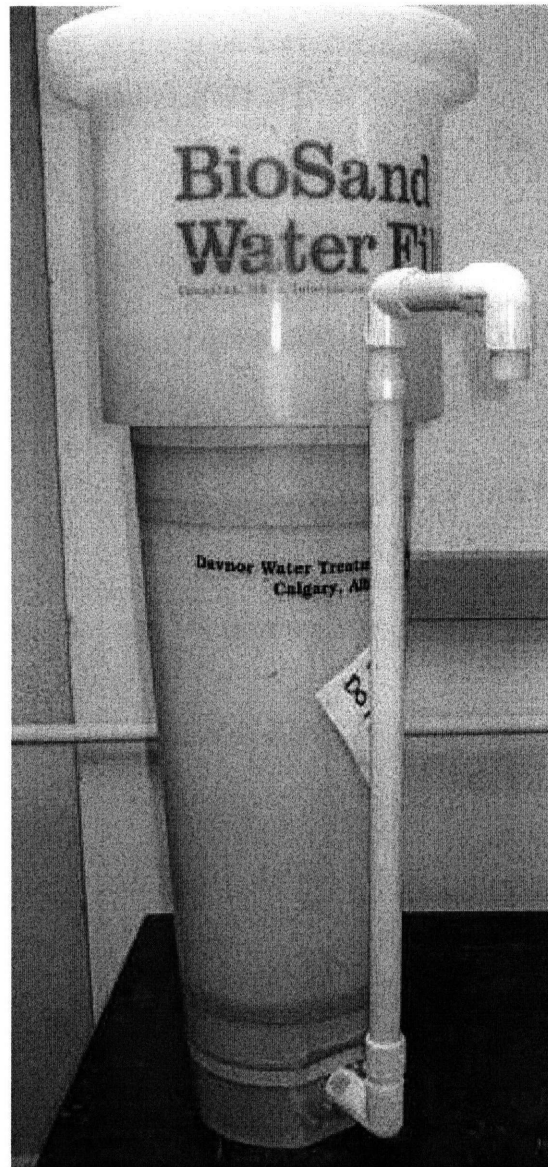

Figure 4-4 Picture of the Plastic Davnor BSF

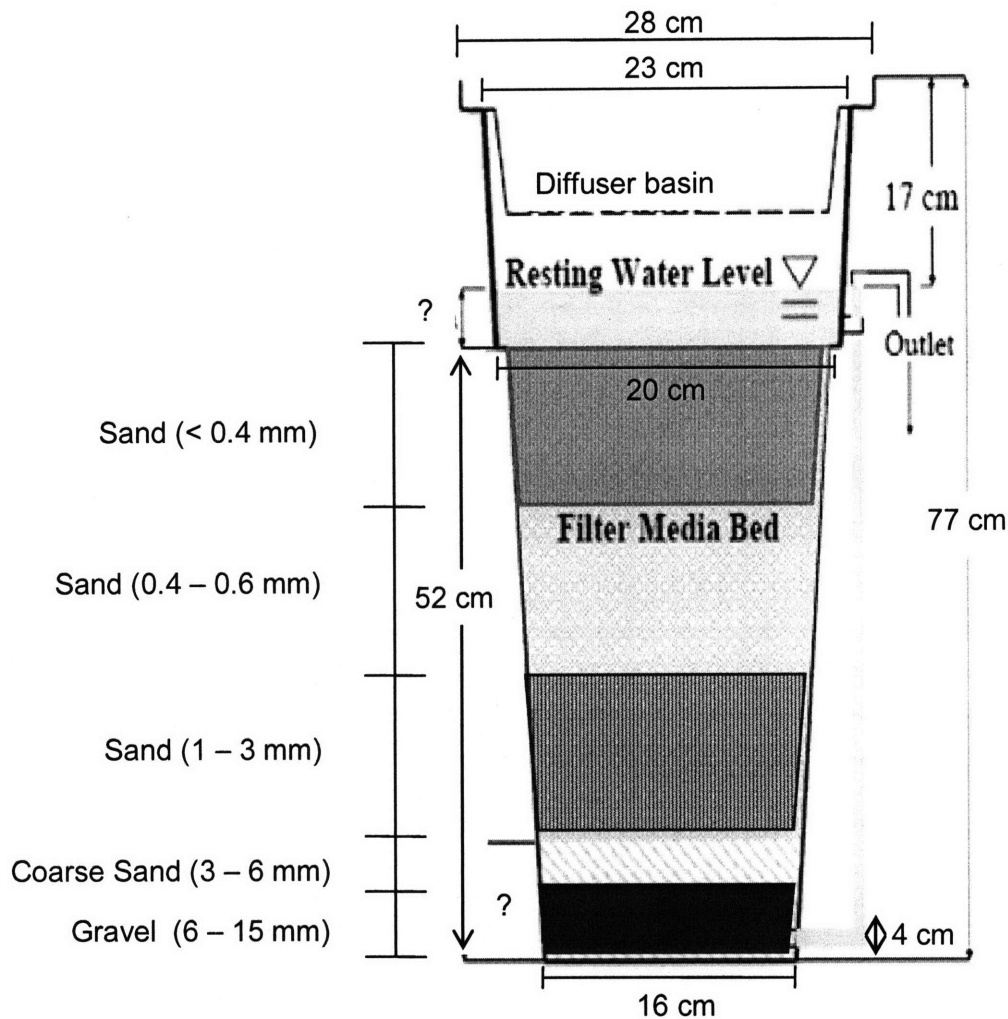

Figure 4-5 Dimensions and Media Specifications of the Plastic Davnor BSF
(Picture: Adapted from Stauber, 2007)

4.2.3 Comparison of the Concrete Rectangular BSF and the Plastic Davnor BSF

As discussed in Chapter 2 and Section 4.1, there are several design factors that would affect the performance efficacy of a BSF, such as sand size, sand depth, and surface loading rate. In general, the better performance is expected with smaller sand size (larger surface area) and longer contact time. However, it is not straightforward to consider the best design since these factors all affect the performance in a way that cannot be described in a single formula.

Table 4-1 shows the values of design factors for the Concrete Rectangular BSF and the Plastic Davnor BSF. It should be noted again that the Plastic Davnor BSF has five different media layers, whereas the Concrete Rectangular BSF has three media layers.

The two designs have similar sand depths of 46 cm and 42 ± 2 cm. Although, the Concrete Rectangular BSF has twice as large values for both the container volume and the cross sectional area, the design flow rate of the two BSFs are similar. As a result, the Plastic Davnor BSF has a surface loading rate that is above the upper value of that of the Concrete Rectangular BSF.

Table 4-1 Comparison of the Concrete BSF and the Plastic Davnor BSF Design

	Container Volume [L]	Average Cross section area [cm ²]	Sand Depth [cm]	Maximum Water Standing Depth [cm]	Surface Loading Rate [m ³ /m ² /hr]	Design Flow Rate [L/hr]
Concrete BSF	47	512	46	34	0.23-0.70	12-36
Plastic Davnor BSF	24	258	* 42 ± 2	* 22	0.78	20

* Estimated Values

In Chapter 7, these two designs will be compared with the two designs (LPD BSF and HydrAid BSF) that will be discussed Chapter 5 and Chapter 6.

5 Local Plastic Design Biosand Filter and its Modification

5.1 Field Site Description

The experiments of the local plastic design (LPD) BSF and its modification were conducted by a dugout called the Ghanasco Dam, located close to the Peace Corps sub office in Tamale. Figure 5-1 shows a map of Tamale, Ghana, and local villages and dugouts. The Ghanasco Dam, shown as a star in the map, is approximately 6 km from Downtown Tamale. As mentioned in Section 1.4.3, the dugouts in Northern Ghana are man-made reservoirs that collect rainwater and intermittent stream flow, and are a common water source for rural homes. Villagers, mostly women and children, walk to the dugout to fetch water for in-house use. They also wash their laundry by the dugouts.

The LPD BSFs were constructed at the Peace Corps sub office by the author with substantial assistance from Peace Corps volunteers, and installed by the Ghanasco Dam. Two modified and two unmodified LPD BSFs were constructed. Material acquisition, construction and installation of the four LPD BSFs took place from December, 2007, through January 13, 2008. This field site was chosen because it was close to the Peace Corps sub office and the water from the dugout, which was used to supply the BSFs on a daily basis, had relatively high turbidity (approximately 300 NTU). The BSFs were installed by the dugout so that the operation of adding water could be done easily, as large volumes were required. Since the BSFs were set in an open field beside the dam, guards were hired to watch the BSFs during day and night.

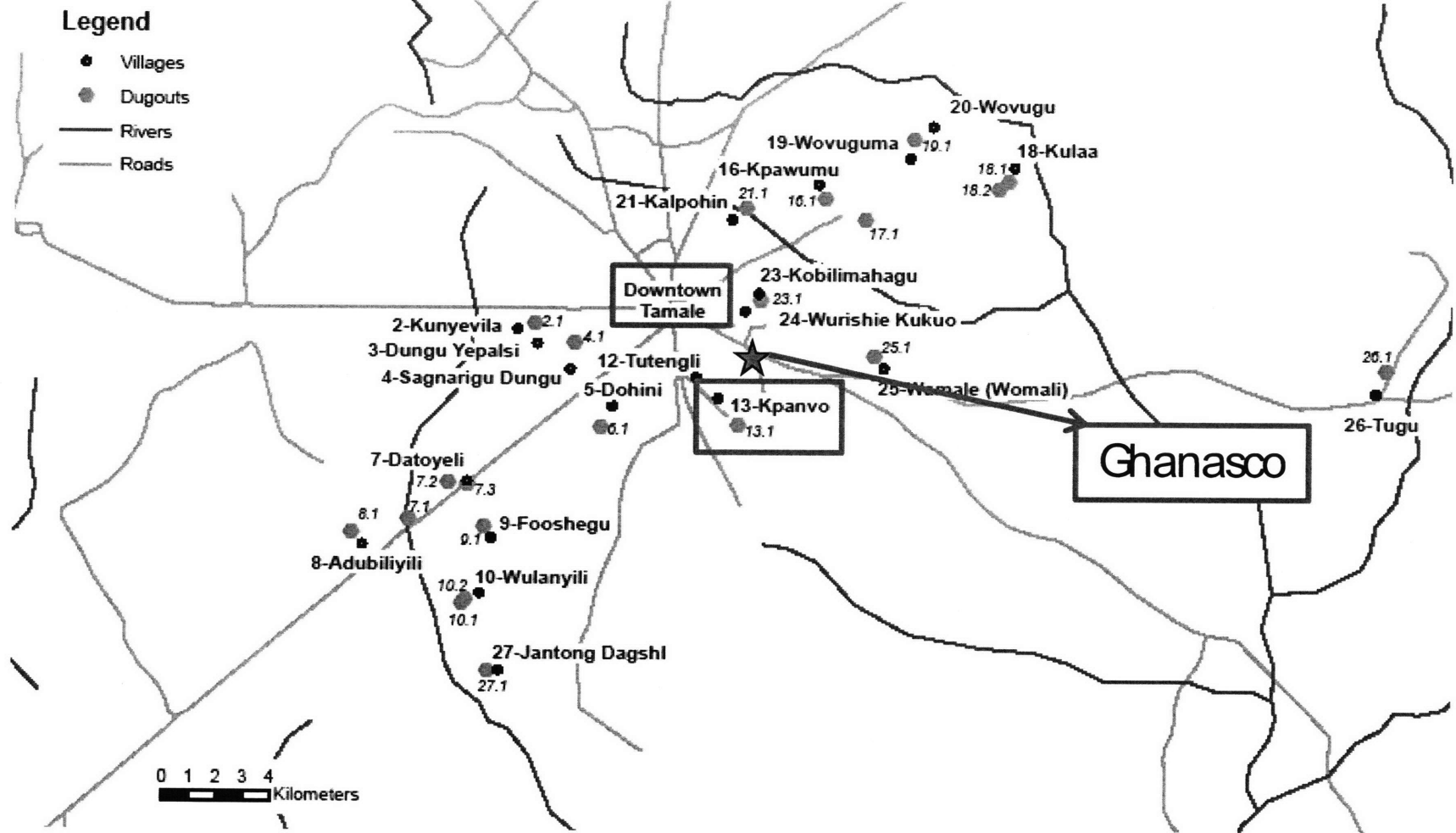

Figure 5-1 Map of Tamale and the Nearby Village/Dugouts

5.2 Local Plastic Design Biosand Filter

The dimensions and media specifications of the local plastic design (LPD) BSF that was constructed is shown in Figure 5-2. The construction of the LPD BSF was carried out based on a construction and installation manual for a plastic BSF (Ngai et al., 2006a), with some minor changes due to availability of equipment in Ghana (Appendix C). The design flow rate of these BSFs is 15-20 L/hr. Maximum and minimum limits of the design flow rate are 30 L/hr and 5 L/hr, respectively (Ngai et al., 2006b). Figure 5-3 shows a picture of a LPD BSF and its diffuser basin constructed with a 50 L plastic bucket following the same construction manual (Ngai et al., 2006a). The volume of the plastic bucket used for the LPD BSF in this research is 50 L as well, but a different type that was obtained from a distributor called Declorplast located in Accra, Ghana.

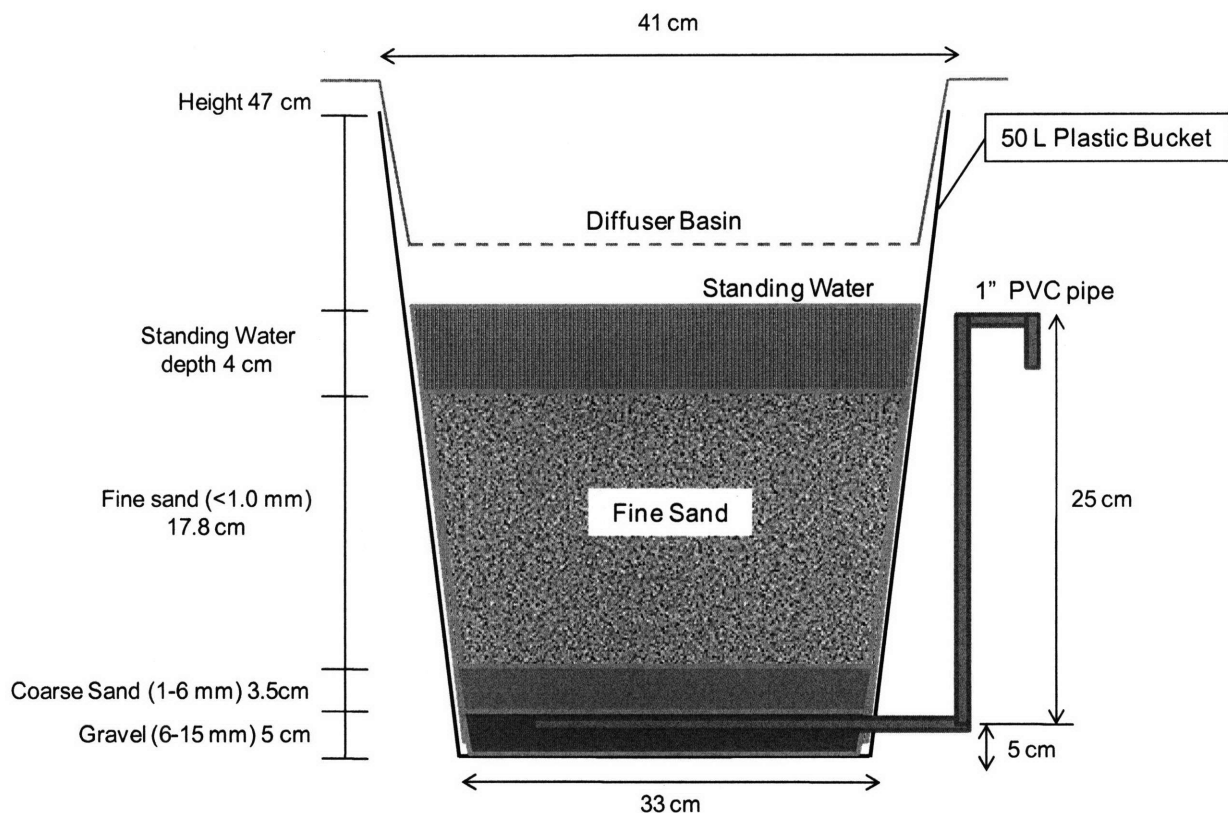

Figure 5-2 Dimensions and Media Specifications of the LPD BSF

The sand depth is approximately 18 cm in the LPD BSF. The gravel and sand sizes of the LPD BSF are identical to the Concrete Rectangular BSF: gravel (6 – 15 mm), coarse sand (1 – 6 mm), and fine sand (<1.0 mm). The surface loading rate calculated from the average cross sectional area and design flow rate is 0.14 - 0.18 m³/m²/hr. These are important design parameters that affect the treatment efficacy, and will be discussed in Chapter 7.



Figure 5-3 Picture of a LPD BSF and Diffuser Basin

5.3 Local Plastic Design Biosand Filter Construction Method

Major filter components and equipment used for one BSF are listed in Table 5-1, with an estimated cost. All of the equipment was obtained locally. The cost was estimated from prices in Ghana, 2005 with 15 % added for assumed price increases. With consideration to the cost of transportation, the cost can be roughly estimated as \$16 - \$25 US dollars.

Table 5-1 Equipment for BSF Construction

Item	Used for...	Cost [US \$]
Plastic Bucket with lid	filter container	\$5.16
Plastic Basin	diffuser plate	\$1.00
PVC Pipe (1 inch)	stand pipe	\$0.64
PVC Pipe fittings (1 inch)	stand pipe	
3 elbows		\$2.31
1 cap		\$0.77
2 adapters		\$1.54
1 bulkhead fitting		\$0.91
Gravel	media	\$1.29
Coarse Sand	media	\$1.04
Fine Sand	media	\$1.29
Other		
PVC glue	piping connections	\$0.07
teflon tape	piping connections	\$0.13
nails	opening small holes in plastic	
metal pipe (copper or GI)	opening holes in plastic bucket	

Sum of Cost = \$16.15

Procedures of Construction of a LPD BSF

A brief step-by-step overview of the construction procedure is given below. The complete construction and installation manual is provided in Appendix C.

1. Sieve the gravel and sand
2. Wash the gravel and sand
3. Construct the filter:
 - a) Cut the PVC pipe (1 inch) in lengths of two 2 inch, one 4 inch, one 8 inch, one 10 inch
 - b) Connect the 3 elbows, the 4", 10", 2" length PVC pipe, and an adapter as shown in Figure4-1. Use PVC glue for the connection.
 - c) On the 8" pipe, mark locations 2 inches from both ends. Connect the cap, 8" PVC pipe, and an adapter as shown in Figure 4-1. This would be the interior pipe in the filter.
 - d) Heat up a small nail and melt two holes (2 mm diameter) at the locations you have marked in c). Be careful not to make the holes to big. The size of the holes would be the limiting factor of the flow rate.

- e) Open a hole in the bucket for setting the standpipe. First, mark a location 2 inches from the bottom of the bucket. Heat the copper pipe with a fire, and melt a hole in the marked location. Be careful not to push too hard. Small cracks near the hole may eventually become big cracks and damage the container.
 - f) Fit and glue the bulkhead fitting in the hole in the bucket.
 - g) After the bulkhead fitting is dry and stable, glue the interior pipe to the inner side of the bulkhead fitting. Make sure that the holes in the interior pipe are facing downwards.
 - h) Glue the standpipe to the outer side of the bulkhead fitting.
4. After all the connections are dry, fill up the container to the top with water. Check for visual leakage from the outside, especially near the bulkhead fitting. Check the flow rate. This should be 0.3-0.5 L/min. If the flow rate is too fast, there may be a leakage in the pipe connection. Check to see if there is no flow when you close the two holes in the interior pipe using your fingers.
5. Construct the diffuser basin:
- Purchase a plastic basin of the correct diameter to fit the plastic bucket. Heat a small nail (1-2 mm in diameter), and melt holes into the plate. The holes should be small and evenly distributed.
6. Filter installation:
- a) Set the container on a flat and stable surface. The filter should not be moved or disturbed after installation.
 - b) Pour water into the filter bucket.
 - c) Slowly add gravel until it covers the interior PVC pipe. In this case it was 3 inches deep.
 - d) Add coarse sand on top of the gravel so that it would form a layer of 1.5 inches.
 - e) Add water until the normal water level.
 - f) Add fine sand until it is 2 inches below the standing water level.
- ** It is normally recommended to chlorinate the bucket and sand before installation. However, in this case the procedure was left out, in order to shorten the ripening period.

5.4 Research Approach for Modification

The next step in this research was to design and construct a modified LPD BSF that would treat highly turbid water. In order to improve the standard (plastic or concrete) BSF, six possible approaches were considered at the outset:

1. Add a unit of sedimentation
2. Add a unit of coagulation
3. Add a unit of roughing filtration
4. Circulate the water flow within the filter
5. Use finer sand in place of the <1.0 mm sand layer
6. Add an additional biolayer

Approaches 1 through 3 are conventional techniques that have been proven to be effective (Schulz & Okun, 1984; Galvis, 1999). Murcott et al. (2007) performed studies of sedimentation and coagulation with raw water from the dugouts in northern Ghana. Sedimentation effects for Libga Dam showed that the turbidity was reduced from 47 TU (64 NTU) to 21 TU (28 NTU), a 55 % reduction within one day. Sedimentation testing of Ghanasco Dam (same site as for this study) was conducted by Losleben (2008) in January, 2008. Turbidity reduction of 57 % was observed in one day for plain sedimentation at the field site. The effects of using a locally obtained coagulant (Alum) also showed good results of an average total coliform reduction of 99.7 %, and an average *E.coli* reduction of 99.4 % (Foran, 2007).

Although approaches 1 through 3 are known to be effective, combining them with the BSF would not be easy. First, sedimentation is actually commonly practiced already by the villagers. When villagers collect water, they often store the water in a clay vessel outside their house. They then use the water at demand. In addition, Ghanasco Dam and all the other dugouts throughout the Northern sector can be considered as settling ponds. Since sedimentation is already being practiced at this household scale, and is taking place at the dugouts, having another unit of sedimentation was rejected as a useful alternative.

The procedure for coagulation is to add a coagulant to raw water, stir it rapidly and then slowly, and let the particles settle. After the particles have settled, the supernatant can be scooped out or the settled particles can be filtered through a cloth or a sand filter. Again, combining this procedure into one process with the BSF was not considered easy or user-friendly, and therefore was rejected.

Roughing filtration at a community scale requires a large amount of gravel (Galvis, 1999). The water is slowly passed through the gravel which could be packed in a vessel that is several

meters long. The amount of media that is necessary for this pre-treatment is not realistic for household treatment. Moreover, the mechanism of the filtration is very similar to slow sand filtration, yet less effective due to the large gravel size and thus small surface area. Therefore, for household treatment, it would be more effective to use sand as pre-treatment instead.

Approaches 4 through 6 are options that would modify the BSF unit itself. Approach 4, circulating a proportion of the water within the BSF was an idea taken from recycling reactions, a common approach in chemical process engineering. The proportionally increased detention time would enhance the extent of reactions. However, if the effluent of a standard BSF has low dissolved oxygen levels, circulating a proportion of this effluent will not be effective.

Using finer sand (Approach 5), will increase the capacity of treatment since the surface area of sand grains will be immensely larger. However, this will also lead to frequent clogging. Moreover, finer sand is likely to be more expensive.

Finally, creating an additional biolayer within the standard BSF unit was selected as the approach to pursue. This idea evolved from the roughing filtration mechanism. Roughing filtration is effective at community levels (Galvis, 1999). While the mechanism follows mechanical straining and effects of biofilms that develop on the gravel surface, it cannot be as effective as using sand. This is actually the virtue of roughing filtration since it enables treatment of large amounts of water with less cleaning frequency. However, for household-scale treatment, using sand as a roughing filtration material will be more effective since it would require smaller amounts of media. The cleaning process is also easier at a household level. Since the biolayer is where most of the purification process proceeds within the BSF, having an additional biolayer will enable more depth to treatment.

5.5 Design Modification

As discussed in the previous section, the design modification in this research was to create an additional biolayer within a BSF. This was carried out by inserting, between the diffuser basin and the filter container, an additional diffuser basin with a sand layer (<1.0 mm) in it (Figure 5-4). The depth of the biolayer within a BSF is roughly estimated to be 5-10 cm (Buzunis, 1995, P. 67). Therefore, the depth of the additional sand layer was set to 5 cm and 10 cm. It was not possible to have a unit with 20 cm of an additional sand layer due to its weight.

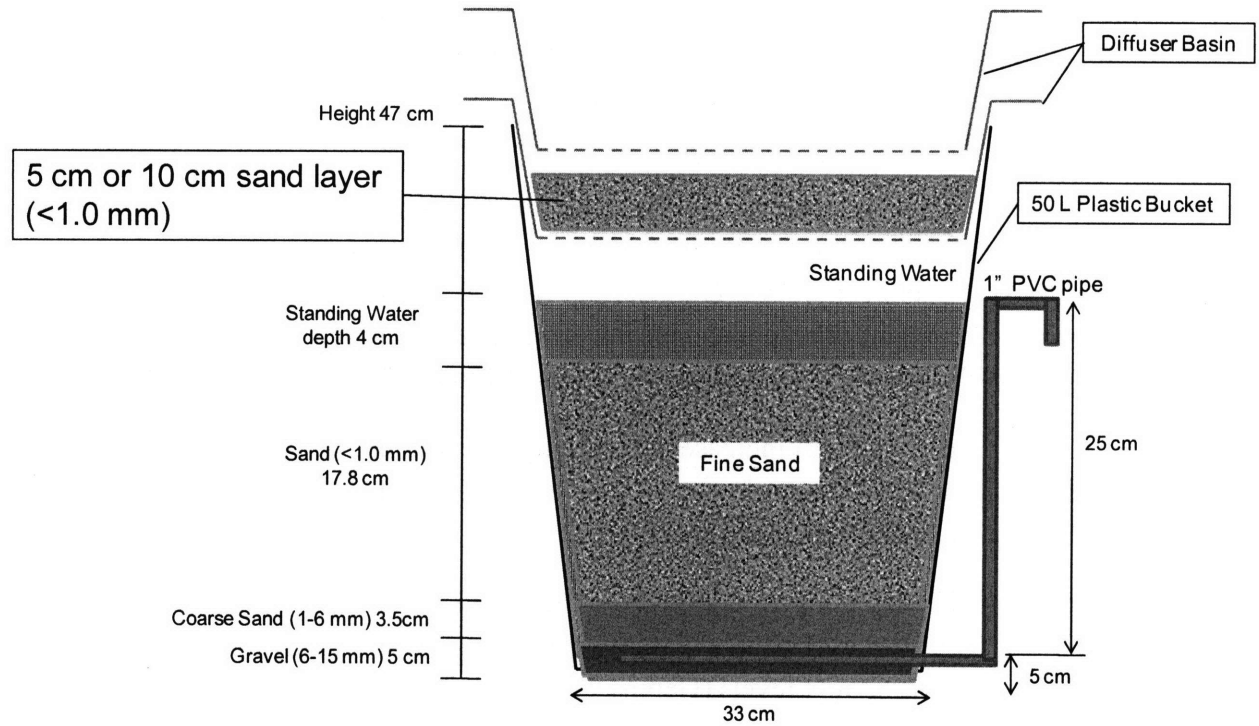

Figure 5-4 Dimensions and Media Specification of a Modified LPD BSF

As shown in Figure 5-5, four BSFs were constructed in total: two BSFs without modification (BSF A and A'), one BSF with an additional sand layer of 5 cm (BSF B), and one BSF with an additional sand layer of 10 cm (BSF C).

For the modified BSFs, it was essential that both biolayers were kept wet and provided with sufficient oxygen. Therefore during pause times (when the filter was not operated), the additional diffuser basins with the sand layer in it were kept inside another basin with water (from the dugout), so that the water level would be roughly 5 cm above the sand layer. During operation, these diffuser basins were placed on the filter container (and beneath the original diffuser basin) (Figure 5-5, Figure 5-6).

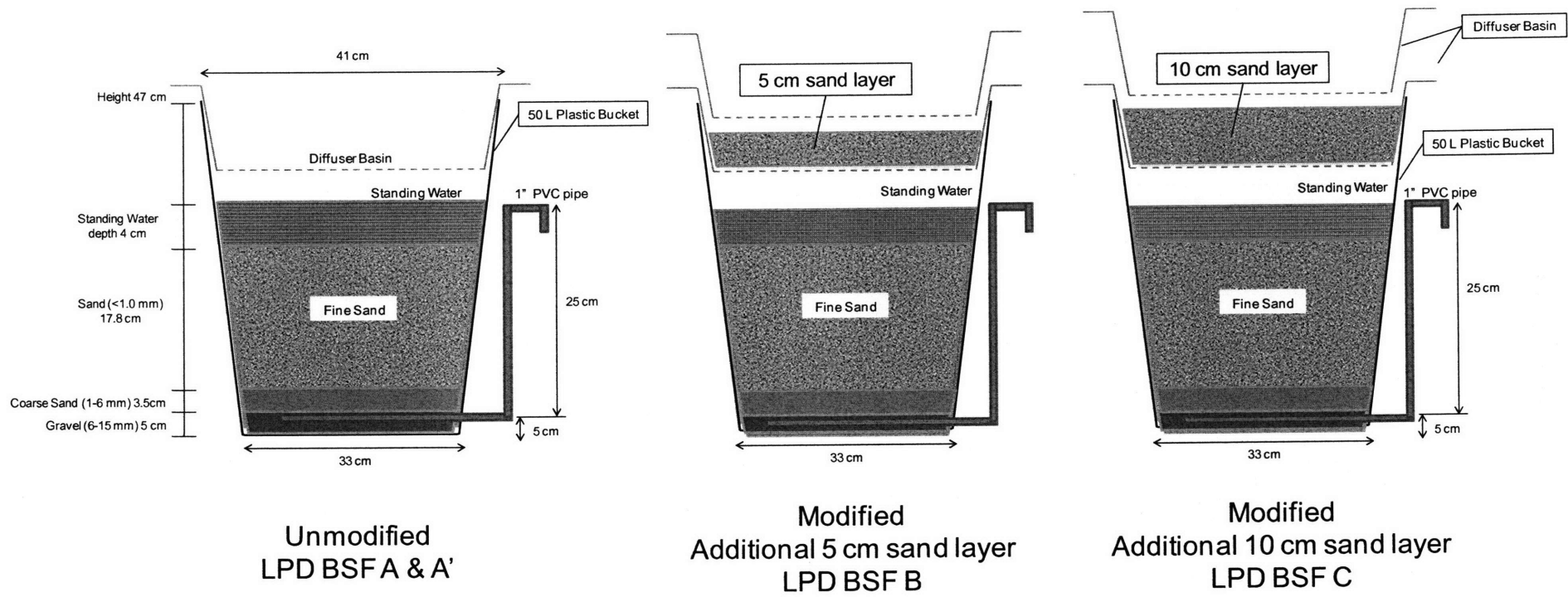

Figure 5-5 Modified and Unmodified LPD BSFs

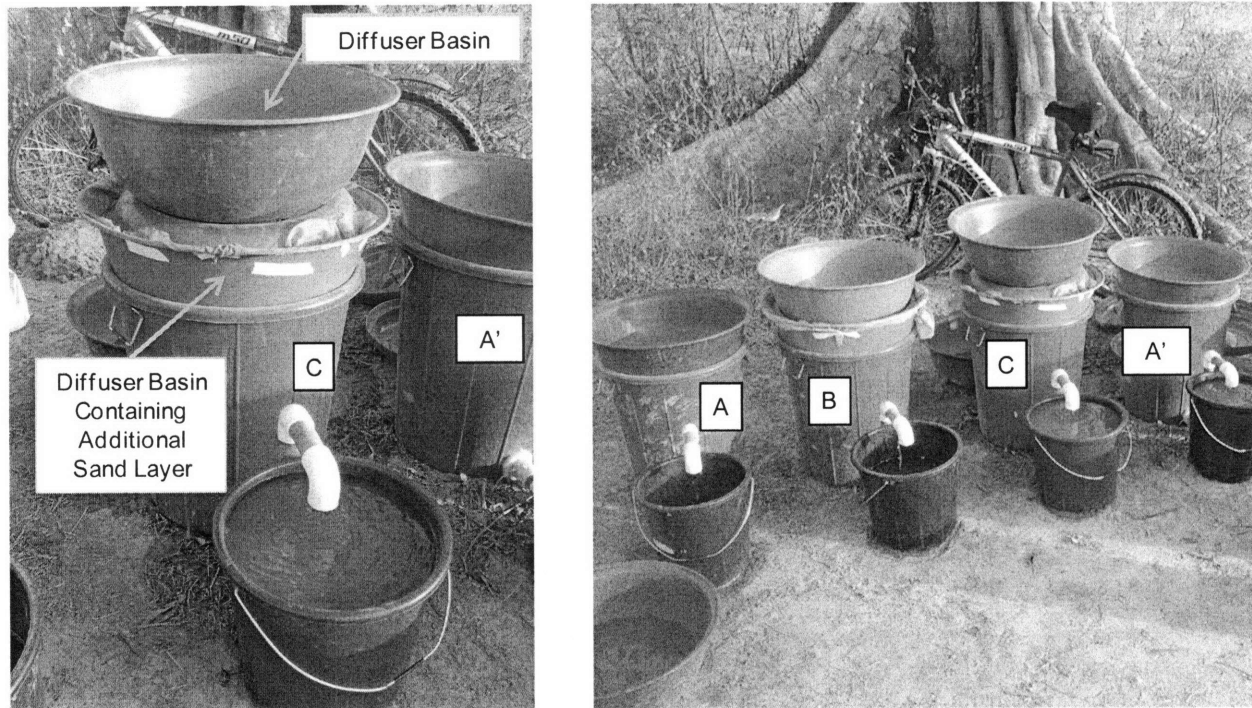

Figure 5-6 Pictures of the Constructed LPD BSFs

5.6 Operation and Evaluation Methods

Following the construction and installation of the four LPD BSFs in December, 2007 through January 13, 2008, operations and evaluations were conducted by the author, with assistance from Peace Corps volunteers, during January 13 through January 24, 2008. This is the period designated as Day 0 through Day 11 after the installation of the BSFs. However, since it takes several weeks for the BSF to ripen, operations and evaluations were subsequently carried out by Peace Corps volunteers after the author's departure until February 28, 2008 (Day 12 through Day 46), in order to determine if performance improved over time. The total period that the LPD BSFs were operated was 46 days.

Basic Operation and Evaluation Methods

All four BSFs were fed 20-30 L of water from the Ghanasco Dam once every day. Before operation, the additional basins with sand were put in place on BSF B and C. First, all four BSFs had 10-15 L of water added. After letting the water flow for 3-5 min, the effluent was sampled for microbial testing, by collecting water in a Whirlpak[®] bag. Then, the Whirlpak[®] bags were put into an insulated cooling bag with icepacks. Next, a clean plastic bottle was used to collect water for turbidity sampling. Finally, additional water was poured into the filters, so that the water level would reach the top of the filter. Flow rates were measured when the water level was maximum, thus providing a consistent head when measuring flow rate. The four BSFs were intentionally not cleaned during the entire 46 days of the experiment.

Ideally, the water level should have been the same for all four BSFs when measuring the flow rate. However, due to the additional basin for the locally-constructed modified BSFs (BSF B and C), it was not possible to make the water level exactly the same as the locally-constructed unmodified BSFs (BSF A and A'). This was because the flow rate through the additional basin was slower than the flow rate through the unmodified BSF unit itself.

The samples in the Whirlpak[®] were taken back to the lab and processed within six hours. Upon arrival at the lab, all surfaces were sterilized with isopropyl alcohol. Sterile technique was followed throughout. First, the pipette tips and glassware were sterilized by boiling. Dilutions were chosen by previous results. After the samples were prepared to the preferable dilutions, 1 ml of the sample was put on a petrifilm (3M), and the petrifilms were put into an incubator (35 °C) for 24 ± 2 hours. Lastly, the coliform colonies were counted.

For turbidity testing, the samples were brought to the lab and tested with a HACH 2100 P turbidimeter. The instrument had been calibrated upon arrival to Ghana. For turbidity measurements taken at the Ghanasco Dam study site, a turbidity tube was used.

Operations and Measurements Conducted by Peace Corps Volunteers

Operations on Days 12 – 46 by Peace Corps volunteers were followed in the same manner as stated above. However, since the Peace Corps volunteers were not available every day, operations were conducted with help from the guards on some days. It must be noted that, according to the Peace Corps volunteers, the guards started drinking the water from the BSFs beginning around Day 20. While the BSFs were fed with influent water once a day until Day 20, it is likely that water was reputedly added to the BSFs multiple times in one day after this date.

Flow rate measurements were conducted in the same method as stated above. However, turbidity readings and microbial testing were conducted in a different method due to logistics with equipment. The turbidity measurements were read by a turbidity tube (HACH), which uses the unit of TU. The detection limit of the turbidity tube is 5 TU.

For microbial testing, the membrane filtration tests (MF) and Hydrogen Sulfide Bacteria Presence/Absence tests were conducted by a Peace Corps volunteer instead of 3M Petrifilm, due to a shortage of 3M media.

5.7 Results

5.7.1 Flow Rate

The flow rate results of the BSF are shown in Figure 5-7. The flow rate ranged from 15 L/hr to 38 L/hr with one minimum outlier at 13 L/hr and one maximum outlier at 45 L/hr. The design flow rate of the unmodified LPD BSF is 15 – 20 L/hr with a minimum limit of 5 L/hr and maximum limit of 30 L/hr. However, it can be observed that during the 46-day period of operation and measurements, the flow rates did not decline (Figure 5-7). Again, the BSFs were not cleaned during this period.

The average flow rates of the four LPD BSFs are shown in Table 5-2. The modified LPD BSFs (BSF B and C) have a slower flow rate. This is likely because the additional basins with sand had slower flow rates than the basic BSF unit, as discussed in Section 5.6. Moreover, since the additional basin induced a slower flow rate, it was not possible to measure the flow rates at the same head as the standard BSFs. The flow rate of BSF A was unintentionally above the design flow rate. The flow rate of BSF A', B, and C were within the design flow rate range.

Table 5-2 Average Flow Rate of Standard and Modified BSFs

BSF	Average flow rate [L/hr] (standard deviation)
A (without modification)	32.0 (4.1)
A' (without modification)	25.9 (4.9)
B (additional 5 cm sand layer)	21.8 (6.0)
C (additional 10 cm sand layer)	21.1 (4.3)

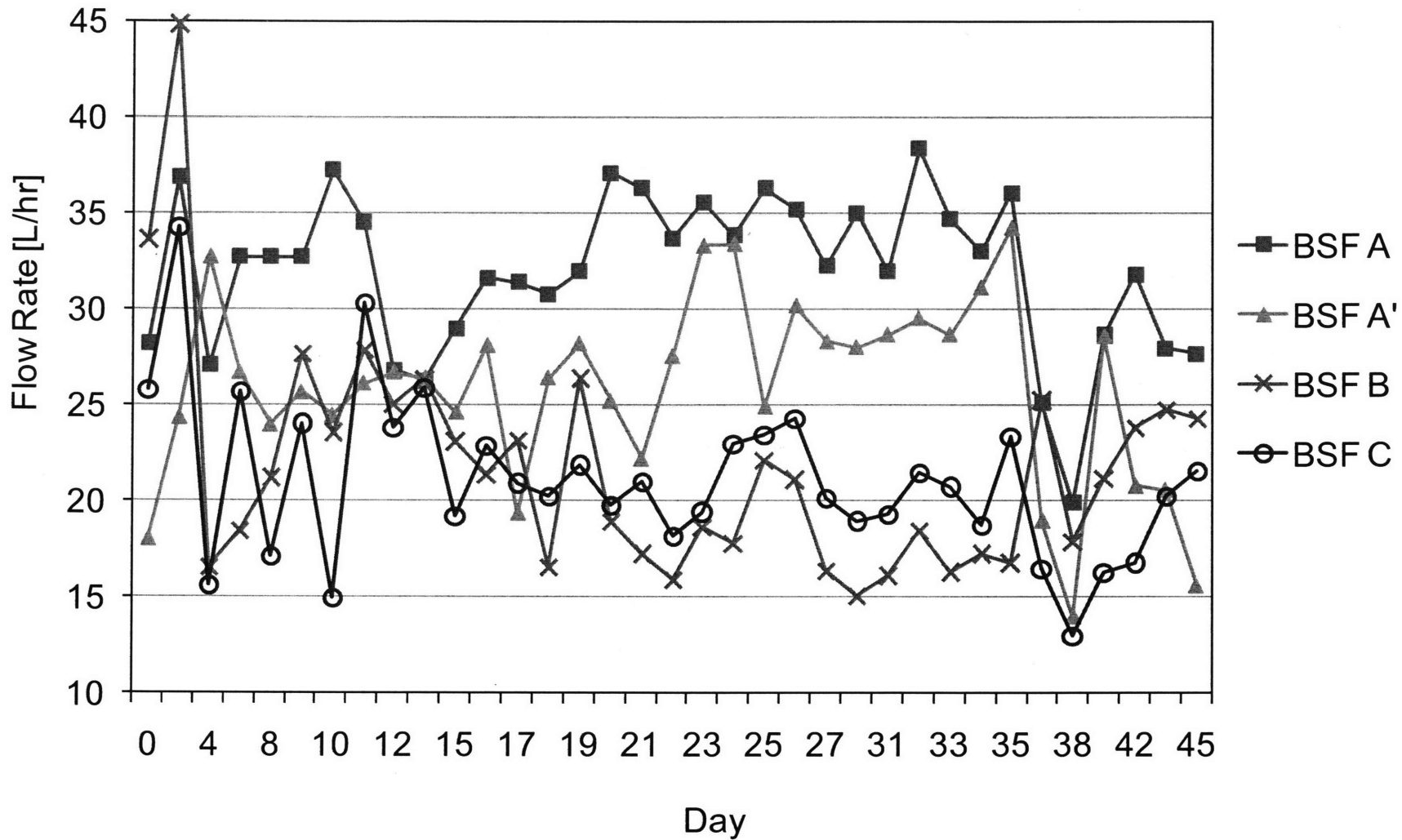

Figure 5-7 Flow Rate of Unmodified (BSF A & A') and Modified BSFs (BSF B & C)

5.7.2 Turbidity

Since the turbidity measurements were conducted in two different methods that give result values in different units, TU and NTU, the turbidity values measured in TU were converted to NTU by using the linear relation between TU and NTU, as discussed in Section 3.3.1.

The turbidity of the dugout varied widely from 175 NTU to 540 NTU (Figure 5-8). However, the turbidity is overall very high with an average of 306 NTU.

As shown in Figure 5-9, the water filtered through the LPD BSFs showed turbidities substantially lower than the raw water from the dugout. The initial turbidity results from all four BSFs were relatively high with turbidity values of 29 – 90 NTU. However, the values decline on Days 11 through 13. The average turbidity of the water from the dugout and water filtered through the BSF are shown in Table 5-3 and Table 5-4. The average turbidity of the filtered water through Days 7 to 11 for BSF A, A', B, and C are 82, 68, 73, and 56 NTU, respectively. The average turbidity of the water filtered through BSF A, A', B, and C during Days 13 to 46 are 22, 20, 15, and 14, respectively. Day 12 is not included since there was no measurement taken on that day. Overall, the turbidity removal of the BSFs was significant during the period of Day 13 to Day 46.

The water filtered through the unmodified BSFs (BSF A and A') showed higher turbidity values after Day 27. The modified BSFs (BSF B and C) showed a mostly constant lower value of 14 NTU during this period.

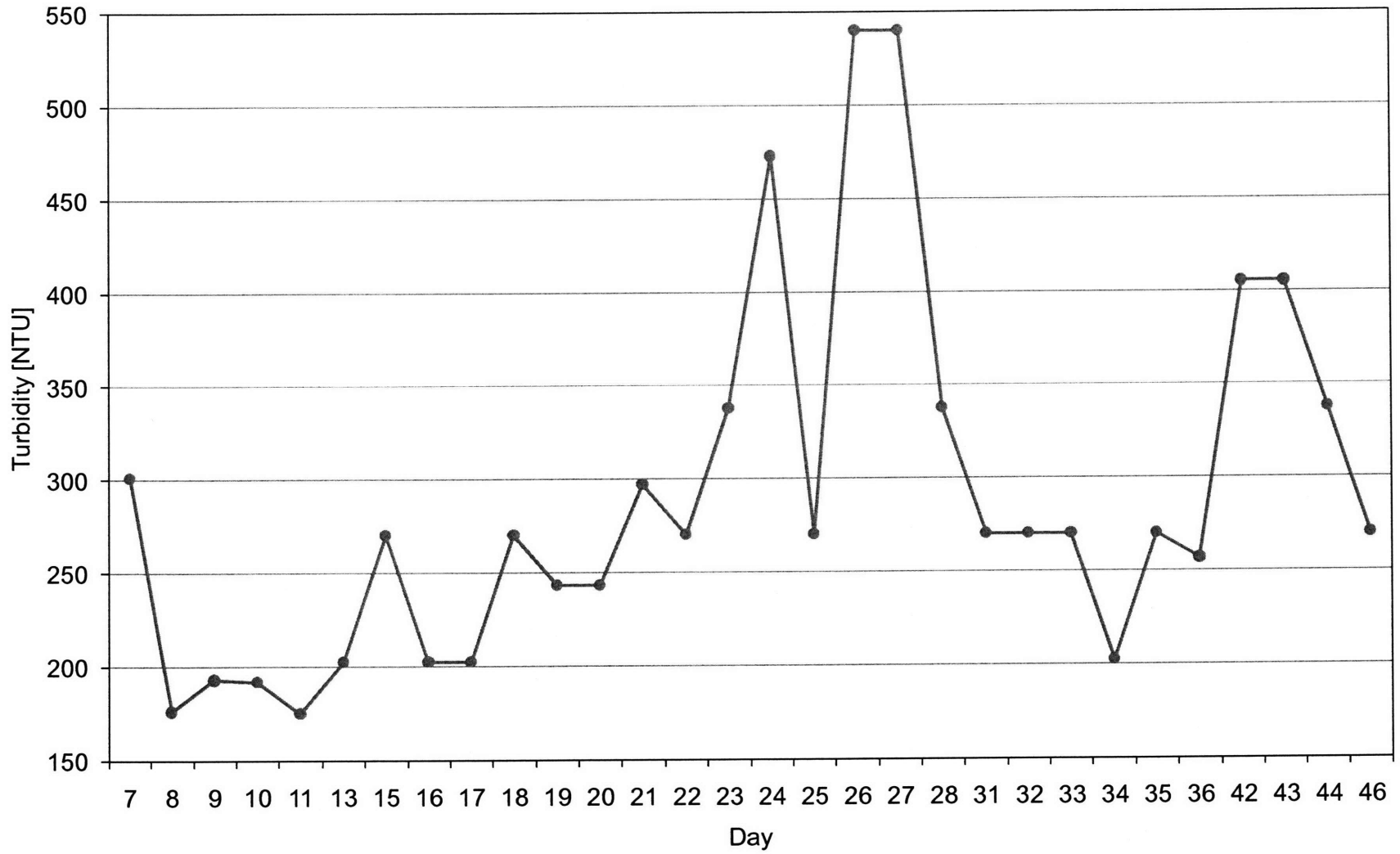

Figure 5-8 Turbidity of the Ghanasco Dam

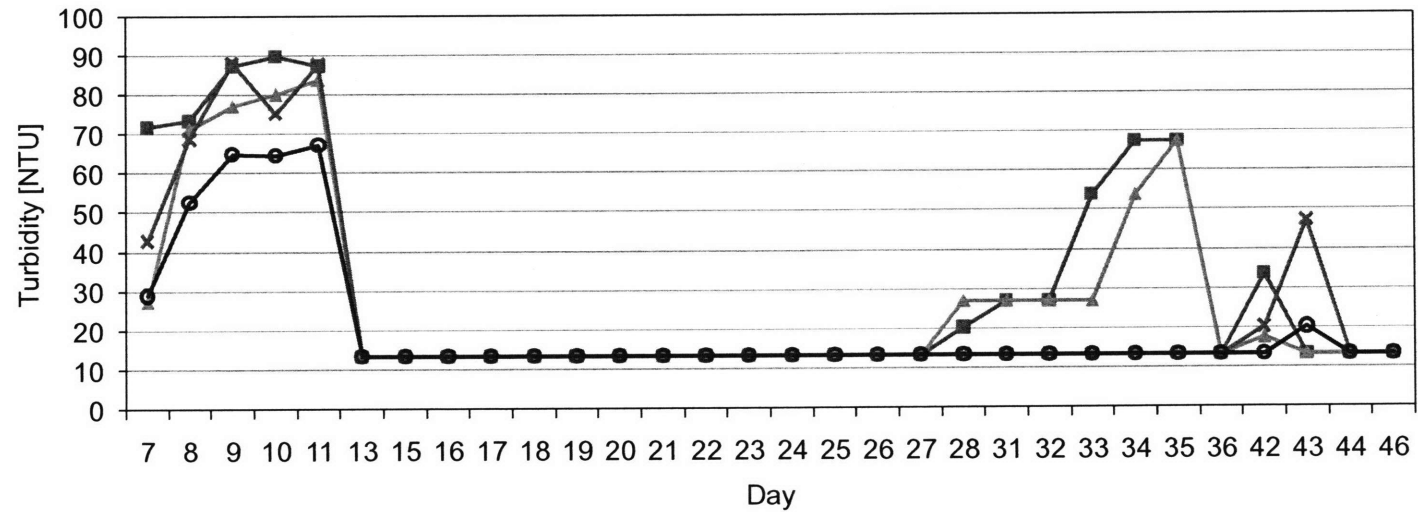
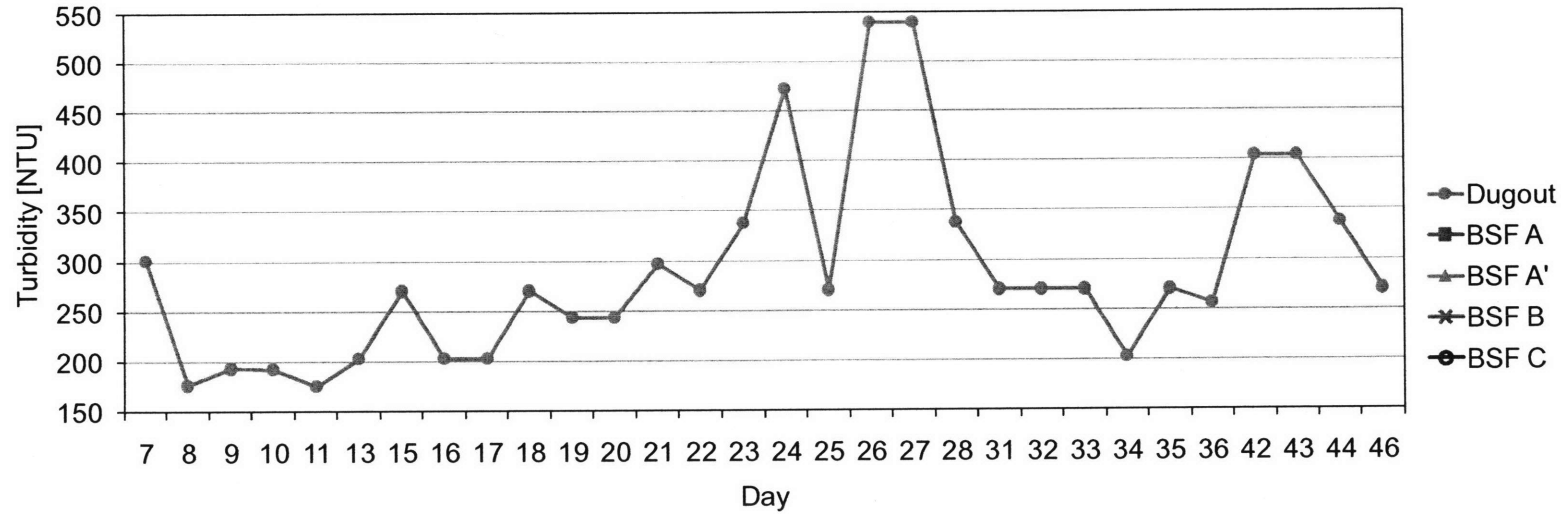

Figure 5-9 Turbidity of the Ghanasco Dam and Effluents of the LPD BSFs (Day 7 – Day 46; TU units converted to NTU)

Table 5-3 Average Turbidity of the Ghanasco Dam and the Water Filtered Through the LPD BSFs (Days 7 to 11)

Dugout and BSF	Average turbidity [NTU] (standard deviation)
Ghanasco Dam	207 (53)
A (without modification)	82 (8.6)
A' (without modification)	68 (23)
B (additional 5 cm sand layer)	73 (19)
C (additional 10 cm sand layer)	56 (16)

Table 5-4 Average Turbidity of the Ghanasco Dam and the Water Filtered Through the LPD BSFs (TU Converted to NTU; Days 13 to 46)

Dugout and BSF	Average turbidity [NTU] (standard deviation)
Ghanasco Dam	306 (97)
A (without modification)	22 (17)
A' (without modification)	20 (14)
B (additional 5 cm sand layer)	15 (6.8)
C (additional 10 cm sand layer)	14 (1.4)

The turbidity percent removal is shown in Figure 5-10. Here, we can see that the turbidity removal of the BSFs improved dramatically after Day 13. This indicates that the filter had ripened by this time. The figure also clearly illustrates the decline in turbidity removal for the unmodified BSFs (BSF A and A') for Days 27 through 36.

The average turbidity percent removal from Day 13 to the end of the study on Day 46 is shown in Table 5-5. The modified BSFs show slightly higher turbidity removal than the standard BSFs. However, it is not clear if this is a statistically significant difference from the standard deviation.

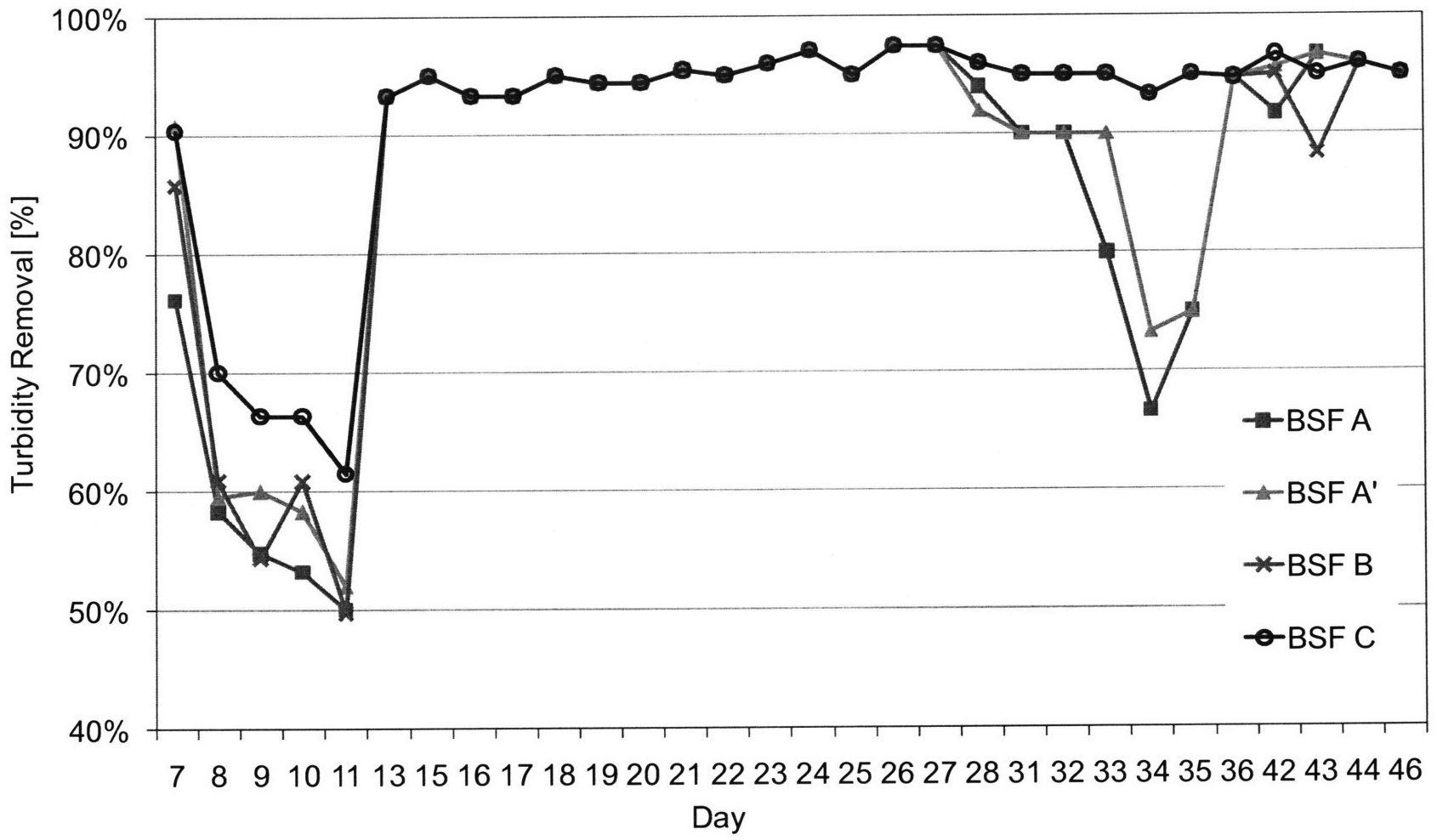

Figure 5-10 Turbidity Removal of the LPD BSFs

Table 5-5 Average Turbidity Percent Removal after Day 13

BSF	Average turbidity removal (standard deviation)
A (without modification)	92 % (7 %)
A' (without modification)	93 % (6 %)
B (additional 5 cm sand layer)	95 % (2 %)
C (additional 10 cm sand layer)	95 % (1 %)

5.7.3 Microbial Testing

Raw water from the dugout and the water that was filtered through the LPD BSFs were tested for total coliform and *E. coli*. *E. coli* colonies were only detected for one sample (100 CFU/100 ml) out of the total 5 samples from the dugout. The samples of water filtered through the BSFs were measured with no dilution. *E. coli* colonies were only detected in two samples (100 CFU/100 ml and 400 CFU/100 ml) out of the 20 samples even in these cases. This indicates that 18 samples were < 100 CFU/100 ml. Raw data of *E. coli* colony counts are shown in Appendix B.

The result of \log_{10} removal of total coliform for Days 7 to 11 is shown in Figure 5-11. This was calculated as $(\log_{10}[\text{influent}] - \log_{10}[\text{effluent}])$. This is the period before the filter had ripened. The average of total coliform colonies in the influent (water from dugout) during this period was 12,000 cfu/100 ml. The average removal percentage for the four BSFs was 86 % for Day 11, with an average effluent concentration of 430 cfu/100 ml. The removal percentage for BSF A, A', B, and C on Day 11 was 90 %, 83 %, 80 %, and 90 %, respectively. The effluent concentration of total coliform for BSF A, A', B, and C on Day 11 was 300 CFU/100 ml, 500 CFU/100 ml, 600 CFU/100 ml, and 300 CFU/100 ml, respectively.

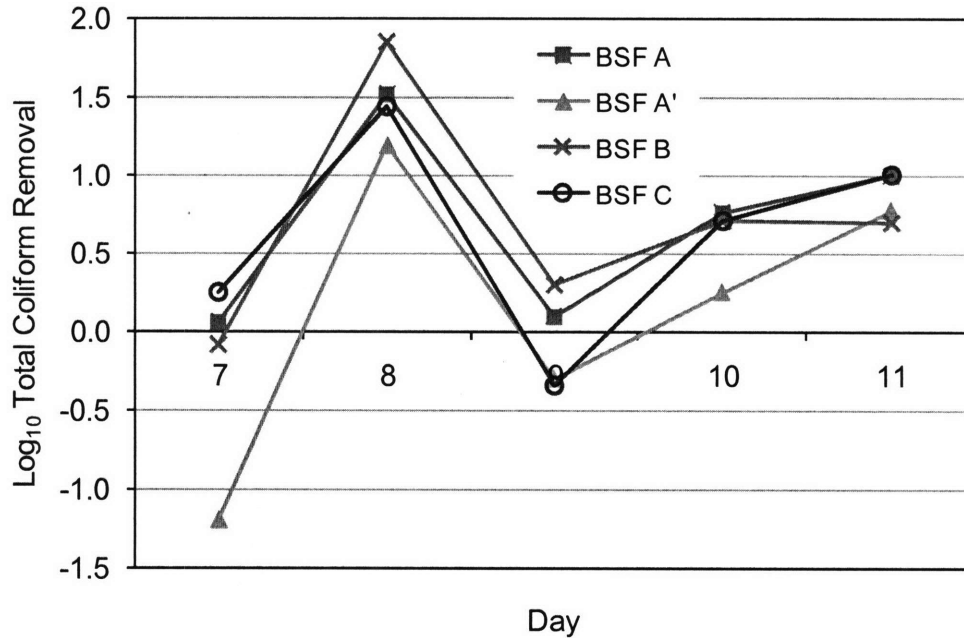

Figure 5-11 Log₁₀ Removal of Total Coliform for Day 7 through Day 11

After Day 12, microbial testing was conducted by a trained Peace Corps volunteer with prior microbiology experience. However, the results from Membrane Filtration tests were inconsistent usually showing no total coliform colony counts for the raw water from the dugout, which seems unlikely, given that prior research had shown total coliform levels of 15,000 cfu/100 ml in Ghanasco Dam. The results from Hydrogen Sulfide Bacteria Presence/Absence tests are shown in Table 5-6. The results indicate that the water from the dugout had microbial contamination, and the water from the BSFs did not have the hydrogen sulfide bacteria in some cases. Therefore, while H₂S Presence/Absence tests do not show quantitative results, we can see the trend that the BSFs seem to be removing bacteria to some extent.

Table 5-6 Hydrogen Sulfide Bacteria Presence/Absence Test Results

Day	38	43	46
Dugout	Present	Present	Present
A (without modification)		Present	Absent
A' (without modification)	Absent	Absent	Present
B (additional 5 cm sand layer)		Absent	Absent
C (additional 10 cm sand layer)		Present	Absent

5.8 Discussion

Flow Rate

As shown in Figure 5-7, the flow rate ranged from 15 L/hr to 38 L/hr with one minimum outlier at 13 L/hr and one maximum outlier at 45 L/hr. The flow rates of the modified and unmodified BSFs did not decline after 46 days of operations. This indicates that the filter did not clog after 46 days of operation.

As mentioned in Section 5.2, the design flow rate of these basic BSF units was 15-20 L/hr. Maximum and minimum limits of the design flow rate are 30 L/hr and 5 L/hr, respectively (Ngai et al., 2006). BSF A shows an average flow rate of 32 L/hr, which is above the maximum limit. This could be due to a slight variation in the construction process. The flow rate greatly depends on the size of the hole in the under drain system. Since this hole is made by melting the PVC pipe by using a heated small nail (<2 mm), the size of the hole can easily become bigger than expected. The other BSFs are well within the normal range. Again, the modified BSFs have slower flow rates due to the additional basin.

Turbidity

The overall average of the water from the dugout was 227 TU (307 NTU). However, turbidities of water from the dugouts in Northern Ghana are known to be extraordinarily high as much as 1000 TU (1350 NTU) or even 2000 TU (2700 NTU) in extreme cases. Therefore, the turbidity of the raw water was not as extreme as possible, but nonetheless still very high.

The variation in the turbidity of the water from the dugout may be due to the time and location of where the water was taken from. The water was more turbid when taken closer to the bank or closer to the bottom. Other effects may be the wind conditions and the usage of the sampling site by others stirring up the sediment. It is also known that the turbidities from the dugout may differ as the dry season proceeds (Murcott et al., 2007). While the turbidity measurements taken by Murcott et al. showed a higher average turbidity value during the rainy season, they have also heard local users say that the water becomes more turbid as the water level in the dugout declines as the dry season proceeds. The turbidity measurement of the Ghanasco Dam presented in this research was taken during January through February, 2008, under the conditions of advancing dry season.

The turbidity removal increased significantly for all four LPD BSFs during Day 11 to 13. This indicates that the filters had ripened at this period. The time for filter ripening was consistent with previous literature stating that it takes 1-3 weeks for filter ripening. All four BSFs showed effective turbidity reduction with averages of 92-95 %, which is typical of BSF performance (Murcott, 2008).

Some of the higher turbidity values from BSF effluents, mostly from the unmodified BSFs (BSF A and A'), toward the end of the experiment period (after Day 27), may be due to presumed difference in operation, such as adding water multiple times a day. It may also be an indication that the unmodified BSFs were in need of cleaning. According to the Peace Corps volunteer that was conducting the operations and measurements during the period after Day 13, the filters were occasionally operated more than one time a day, due to the guard's drinking water from the BSFs.

While it is unknown, to what extent the operation varied, or if the four LPD BSFs were operated with the same variation, the modified LPD BSFs (BSF B and C) did not show the same trend as the unmodified LPD BSFs. The modified BSFs showed the same effluent turbidities as the period of Day 13 through Day 26. Although there is a possibility that the modified BSFs were treated differently by the guards, the difference in the results between the modified and unmodified BSFs could possibly be an indication that the modified BSFs have longer filter life (less frequent need of cleaning), or an indication that the modified LPD BSFs withstand greater operational variation.

E. coli/Total Coliform

Due to unforeseen glitches in power supply, hence in Membrane Filtration sample incubation, quantitative results were not obtained for *E. coli*/total coliform removal after the ripening period. However, the total coliform removal was effective on Day 11 with removal percentages of 80 % - 90 %, and an average effluent concentration of 430 cfu/100 ml.

It is unknown why no total coliform/*E. coli* colonies were detected in the membrane filtration tests after the ripening period. However, it is worth noting that some dugouts in Northern Region, Ghana are being treated with a larvicide, ABATE (BASF AG, Ludwigshafen, Germany) in order to eradicate guinea worm incidences. The effects of ABATE on coliform bacteria is unknown.

The Hydrogen Sulfide Bacteria Presence/Absence test shows the trend that the water from the dugout had microbial contamination, while the effluent from the BSFs were absent of Hydrogen Sulfide Bacteria in some cases. In order to prove the true efficacy of the BSFs, further microbial testing is essential.

5.9 Conclusions

The flow rates of the four BSFs were mostly within range of the design flow rate. The modified LPD BSFs had slower flow rates due to the additional basin. After 46 days of operation, the flow rates did not decline, indicating that the filters did not clog during this period.

All four LPD BSFs showed effective turbidity reduction with averages of 92-95 %. Modified BSFs showed better turbidity removal after Day 27. This could possibly be indications of the enhanced capacity of the modified BSFs, either having longer filter life (less frequent cleaning), or the ability to withstand greater operational variation.

Effective removal of *E. coli*/total coliform was not confirmed quantitatively. However, the total coliform removal was effective on Day 11 with removal percentages of 80 % - 90 %, and an average effluent concentration of 430 cfu/100 ml. *E. coli* colonies were mostly not detected in the influent or effluent.

6 HydrAid Biosand Filters

6.1 Research Approach

The second part of the research was to evaluate BSFs that had been already installed in Ghana. One month prior to the author's visit to Ghana, 200 BSFs were installed in a local village called Kpanvo (Figure 5-1), which coincidentally was a village in which Pure Home Water had already sold ceramic pot (*Kosim*) filters in May, 2007. In December, 2007, these BSFs were provided free by the NGO, International Aid, to the entire Kpanvo community including to households with *Kosim* Filters. The installation was helped by a trained Peace Corps volunteer. These BSFs are called the HydrAid™ BioSand Water Filter. The HydrAid BSFs' plastic container are produced in the U.S. and cost \$32 for the plastic container (International Aid, 2007). The complete system with sand and gravel costs \$50 - \$65 (J. Bodennes, personal communication with S. Murcott, 2008; International Aid, 2007). The design flow rate for this unit is approximately 47 L/hr (International Aid, 2007).

The HydrAid BSF that is provided by International Aid also has a modification from a conventional BSF. As shown in Figure 4-1, a conventional BSF has three layers: gravel, coarse sand (or fine gravel), and fine sand. The HydrAid BSF (Figure 6-1) has an additional layer of superfine sand at the very top. As discussed earlier, using finer sand would increase the surface area of sand that entraps suspended solids and microorganisms. Therefore, this modification is not dissimilar to those made on the LPD BSFs described in Chapter 5, and may extend the ability of treatment of the HydrAid BSF. However, studies are required to understand to what extent the treatment is improved.

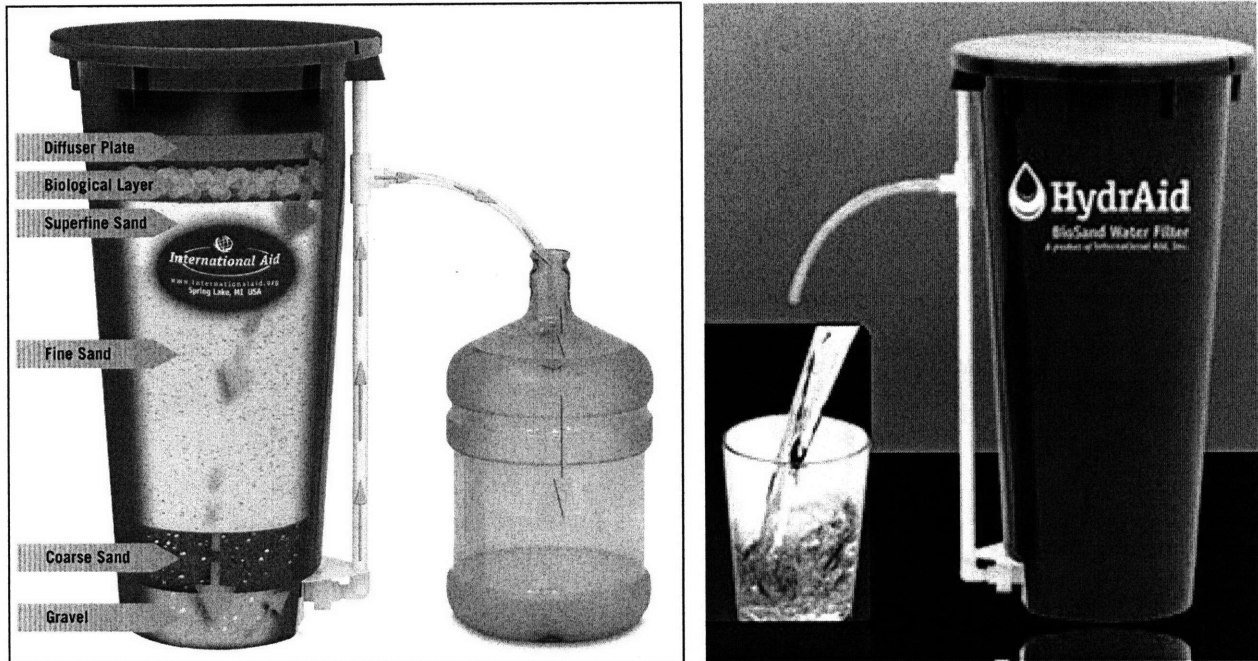

Figure 6-1 HydrAid BSF Provided by International Aid (left) and the Author Taking Water Samples in Kpanvo (right)

(Source: http://www.internationalaid.org/initiatives/safe_water/bio_sand_filter.php)

6.2 HydrAid BSF Design

The dimensions of the HydrAid BSF are shown in Figure 6-2. The design flow rate of the HydrAid BSF is 47 L/hr (International Aid, 2007). By calculating the average cross sectional area, the surface loading rate can be estimated as $0.52 \text{ m}^3/\text{m}^2/\text{hr}$. The additional layer of superfine sand is 5.1 cm. The sand size of this superfine sand is estimated to be $< 0.4 \text{ mm}$ based on the author's observation. The other gravel and sand sizes are also unknown. However, it is likely that the sizes are in the same range as stated in the Concrete Rectangular BSF and LPD BSF: gravel (6-15 mm), coarse sand (1-6 mm), fine sand ($< 1.0 \text{ mm}$). The total sand layer depth (superfine sand and fine sand) is 43 cm.

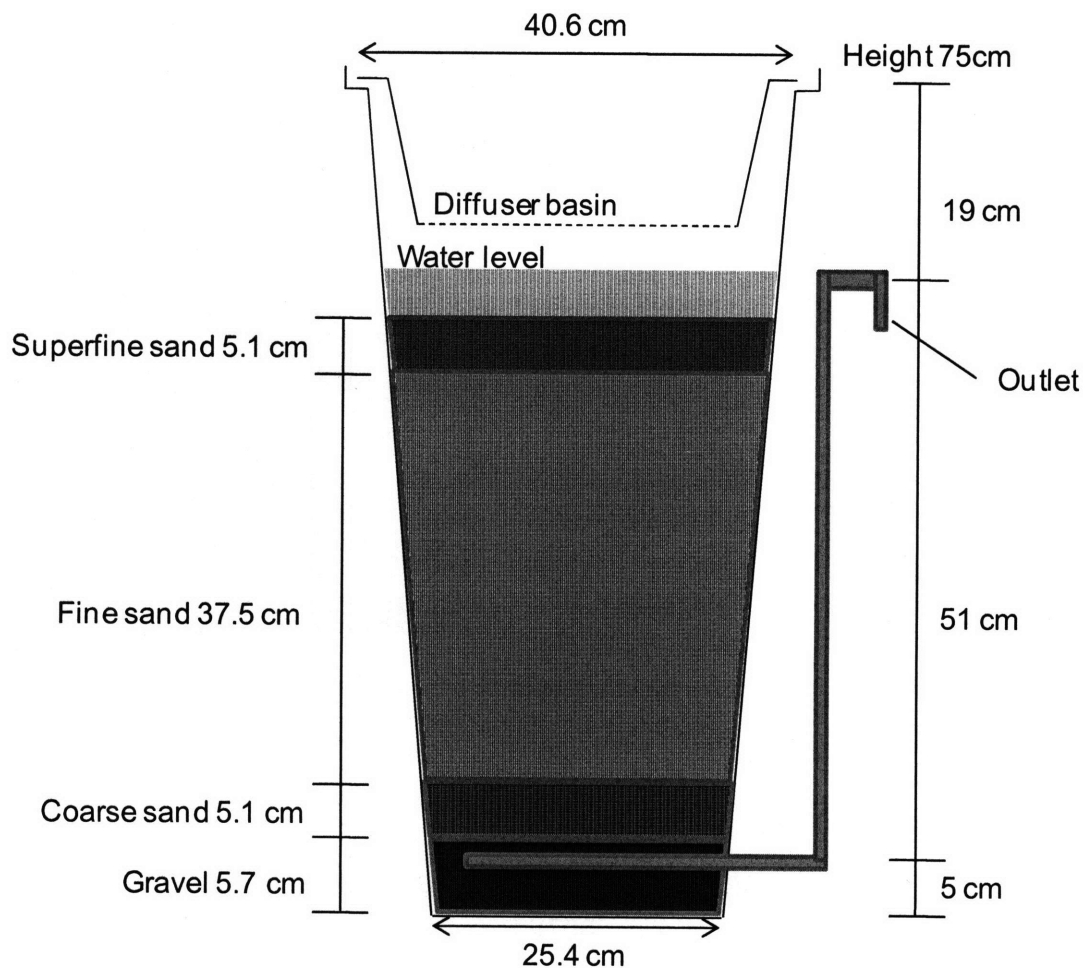

Figure 6-2 Dimensions of HydrAid BSF (Sand size specification unknown)

6.3 Field Site Description

The villagers at Kpanvo used water from the Kpanvo dugout as their water source. Women normally walked to the dugout in the morning, carried water back to their homes, and stored the water in a large clay storage vessel outside their houses. When in need of drinking water, they fetched water from their outside storage using a container, commonly a metal can, and poured it into their BSF. Figure 6-3 shows the villagers using a foot pump to extract water from Kpanvo Dam, the local dugout in Kpanvo village. Figure 6-4 shows a woman of Kpanvo collecting water, with a tin can, from the clay storage vessel in her household compound.

While the author's primary goal was to evaluate the treatment efficacy of the HydrAid BSF for highly turbid influent water, the turbidity of the Kpanvo Dam was not as high as the worst situations in Northern Region, Ghana (Figure 6-5). As it will be discussed in Section 6.5, the

average turbidity of Kpanvo Dam was 85 NTU. The total coliform concentration was high with an average of 20,000 CFU/100 ml.



Figure 6-3 Villagers Using Foot Pump at the Kpanvo Dam

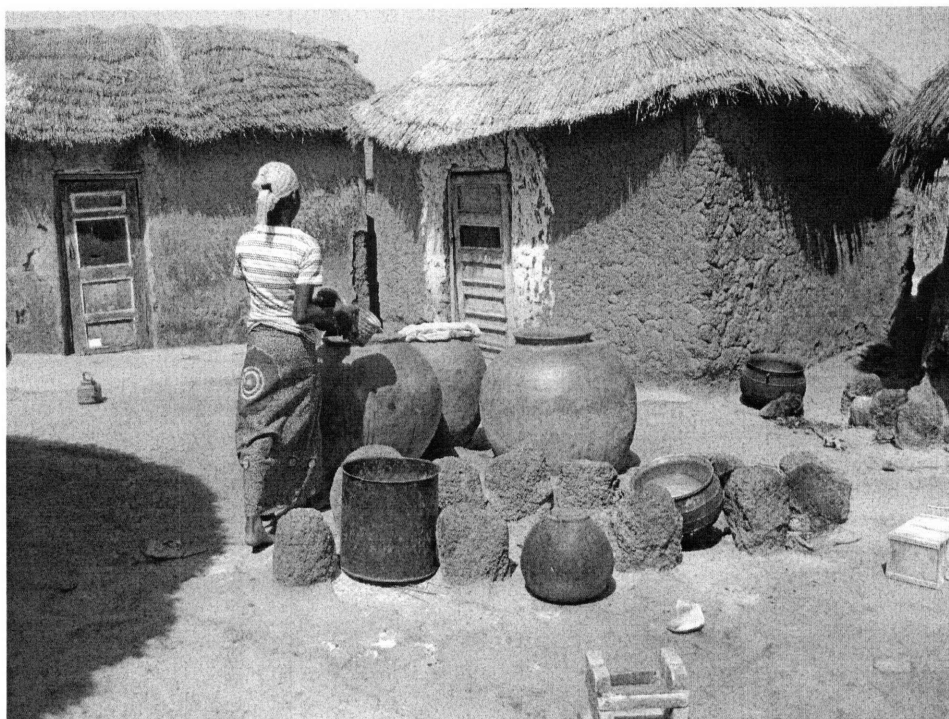

Figure 6-4 House in Kpanvo Village

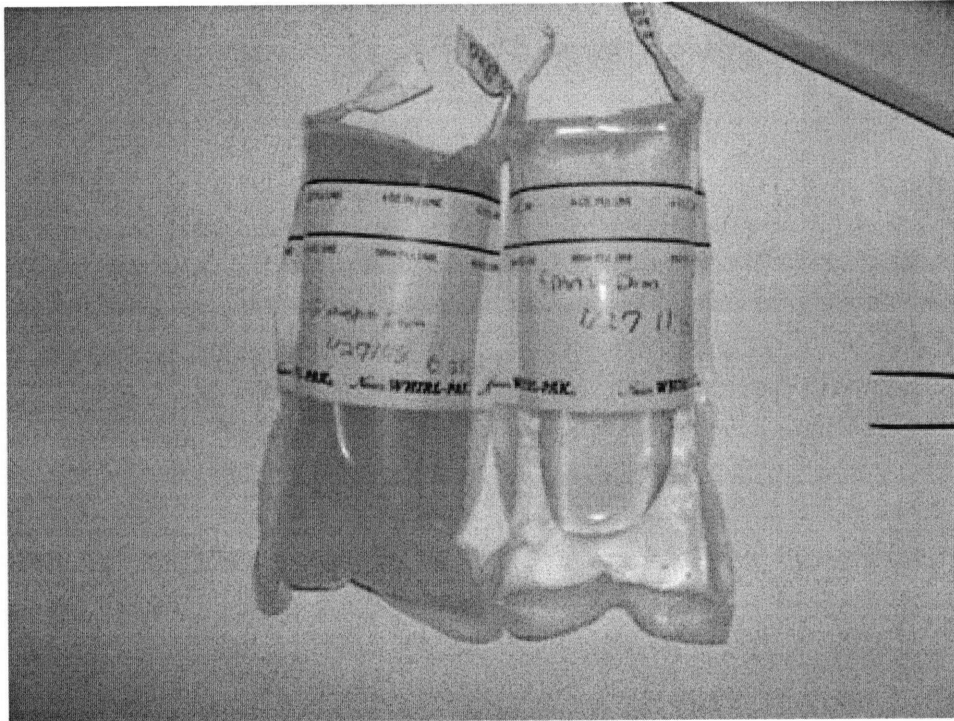

Figure 6-5 Water Samples from Kpanvo Dam (right) and Ghanasco Dam (left) in Whirlpak® Bags

(Photo Credit: Sophie Walewijk)

6.4 Sampling and Evaluation Methods

Sampling and evaluations of the HydrAid BSFs were jointly conducted by the author and Sophie Walewijk, a PhD candidate in Civil and Environmental Engineering at Stanford University. We have visited 30 households and evaluated the treatment efficiency of their filters. Whirlpak® bags were used to take water samples for microbial testing (Figure 6-5, Figure 6-6). For seven households, samples were taken only from the outlet of the BSF. For the rest of the households, samples were taken from the water that was stored outside the household in storage pots (Figure 6-4) from the household compound (the influent), the outlet of the BSF, and the post treatment storage vessel that was placed beneath the BSF, if there was one. The Whirlpak® bags were stored in an insulated cooling bag with icepacks, until the samples were transported to the lab and analyzed within 6 hours.



Figure 6-6 Picture of the Author Collecting a Water Sample from a HydrAid BSF

Upon arrival at a household, we asked the householder to pour some water into the BSF so that we could sample the effluent. For the LPD BSFs, it was typical that large amounts of water (20 – 30 L) were poured into the LPD BSFs during operation and measurements of flow rate (Section 5.6). However, we did not ask the villagers to pour a large amount of water into their HydrAid BSF when we measured the flow rate. This was because the villagers spend a lot of time and effort in collecting the water. Therefore, the flow rates measured are not exactly comparable to the flow rates measured for the LPD BSFs tested by the Ghanasco Dam, where the flow rate was measured when the head was maximum. In addition, it should be mentioned that the overall volume of the two systems differ. While the LPD BSF has an overall container volume of 50 L, the HydrAid BSF has an overall container volume of 66 L (estimated from dimensions shown in Figure 6-2). The amount of water poured into the HydrAid BSFs by the villagers was not consistently the same amount, meaning that the flow rate was not measured at constant head. The water added was typically less than 2 L. Nevertheless, the flow rate of an operating BSF is an important parameter, and therefore the results will be discussed in Section 6.5.1.

Samples were taken back to the lab, and microbial testing was conducted using the Petrifilms (3M) as well as the Membrane Filtration, in the same manner as described in Section 3.3.2. Turbidity measurements were taken from the samples collected in the Whirlpak[®] bags, and measured with the HACH 2100 P Turbidimeter.

6.5 Results

The flow rate results are presented in Section 6.5.1. The turbidity and microbial testing results are presented in Section 6.5.2 and Section 6.5.3. These sections focus on the treatment efficiency of the HydrAid BSF unit itself. Therefore, the results are limited to the water quality of the dugout and influent/effluent of the HydrAid BSF. The transition of the water quality through the different stages of treatment will be presented in Section 6.5.4, including the water quality of the post-treatment storage unit.

6.5.1 Flow Rate

A histogram of the measured flow rates for the HydrAid BSFs is shown in Figure 6-7.

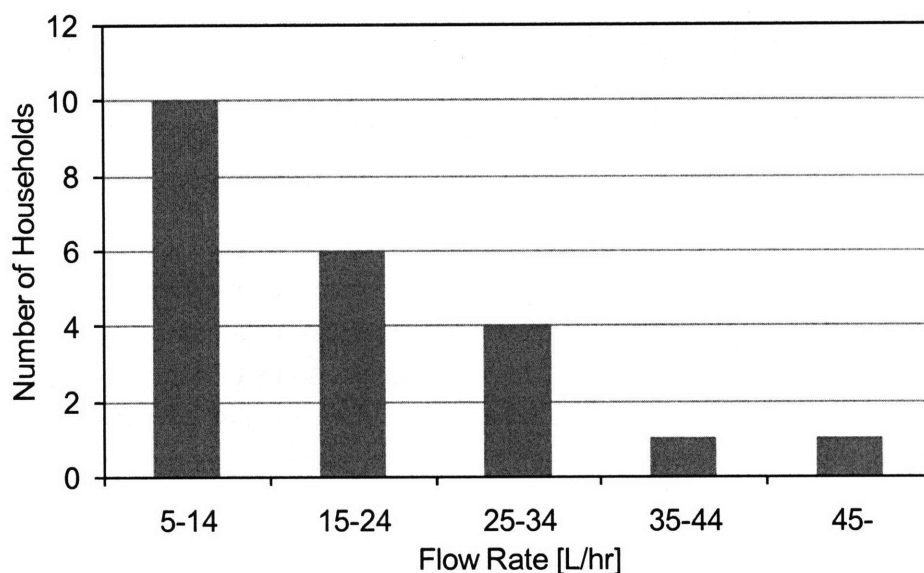

Figure 6-7 Histogram of Flow Rates for HydrAid BSFs

As mentioned in Section 6.1, the design flow rate of the HydrAid BSF is 47 L/hr. Since the flow rates were not measured at maximum head, the results in Figure 6-7 show much slower flow rates than the design flow rate. The average flow rate was 17 L/hr.

Most of the villagers have stated that they clean their filter once in every 3 days.

6.5.2 Turbidity

The average turbidity of Kpanvo Dam was 85 NTU, from three data points of 36 NTU, 85 NTU, and 100 TU (135 NTU). The turbidity values of the influent and effluent to the HydrAid BSFs are shown in Figure 6-8. The average turbidity of the influent water was 32 NTU, and the average effluent was 2.9 NTU. The percent removal percentage of turbidity is shown in Figure

6-9. The household numbers in Figure 6-9 correspond with Figure 6-8. The average removal percentage was 87 %.

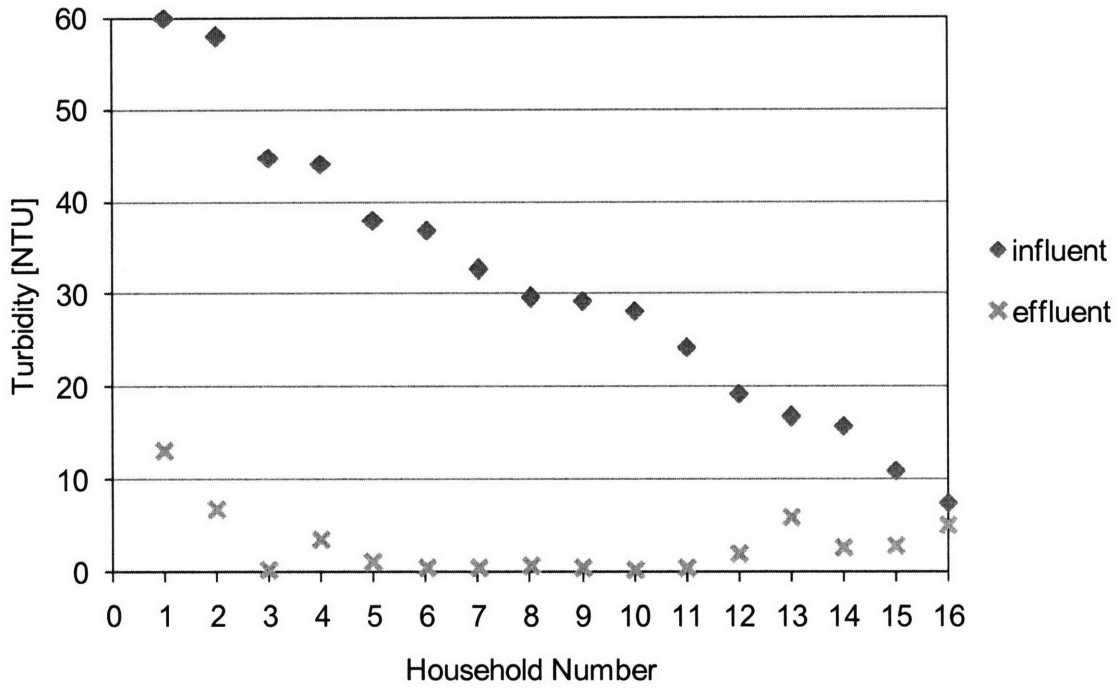

Figure 6-8 Turbidity Values of Influent/Effluent of the HydrAid BSFs

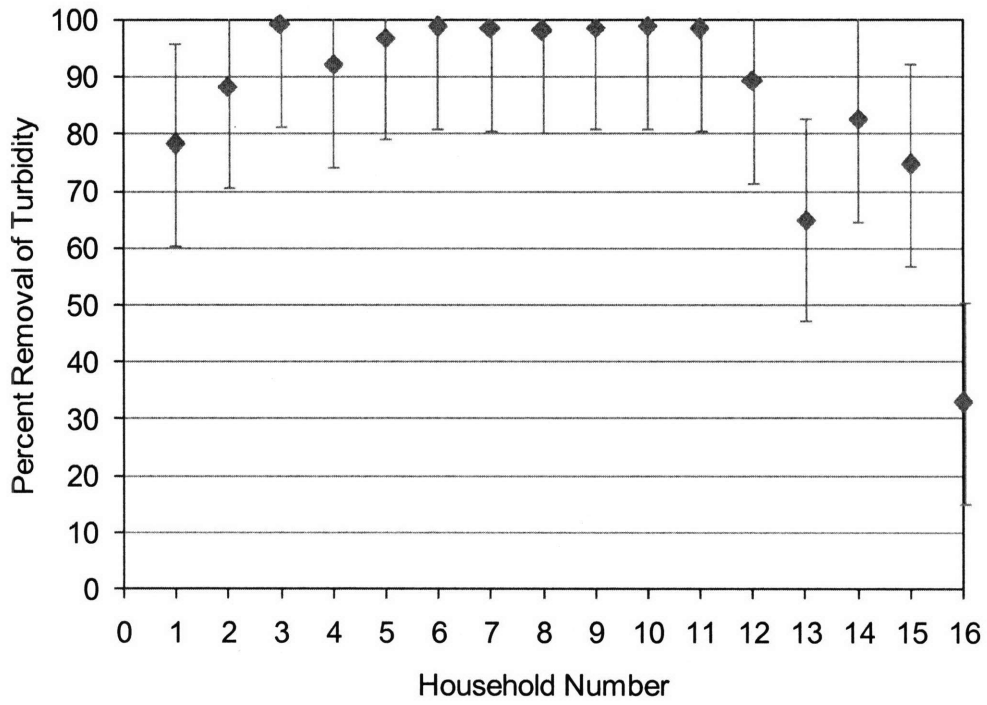

Figure 6-9 Turbidity Percent Removal of HydrAid BSFs

The histogram of the influent turbidity is shown in Figure 6-10. The average influent turbidity was 32 NTU.

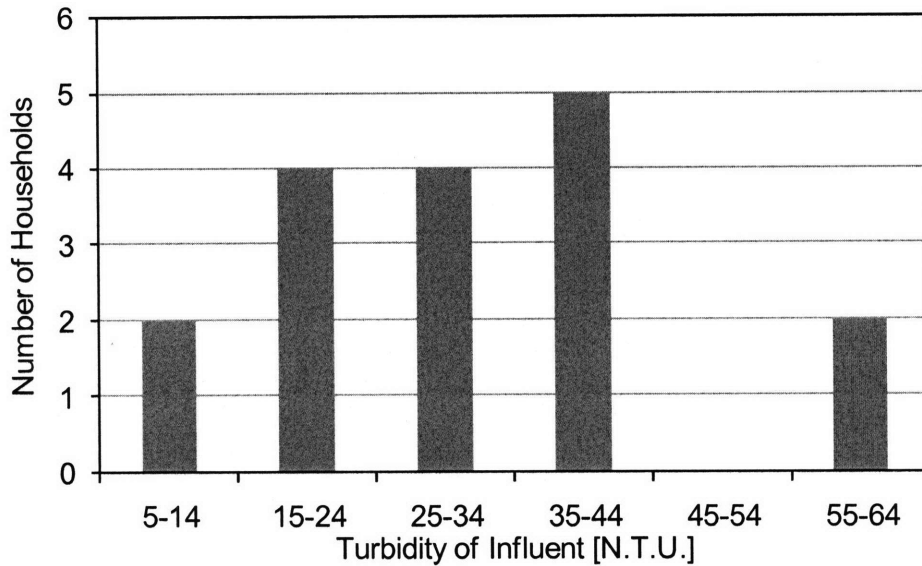

Figure 6-10 Histogram of Turbidity of Influent for HydrAid BSFs

The histogram of the turbidity of the effluent of the BSF is shown in Figure 6-11. Although 25 % of the BSFs gave effluent turbidities that were > 5 NTU, 44 % of the effluent samples have shown turbidities < 1 NTU. The average effluent turbidity was 2.9 NTU.

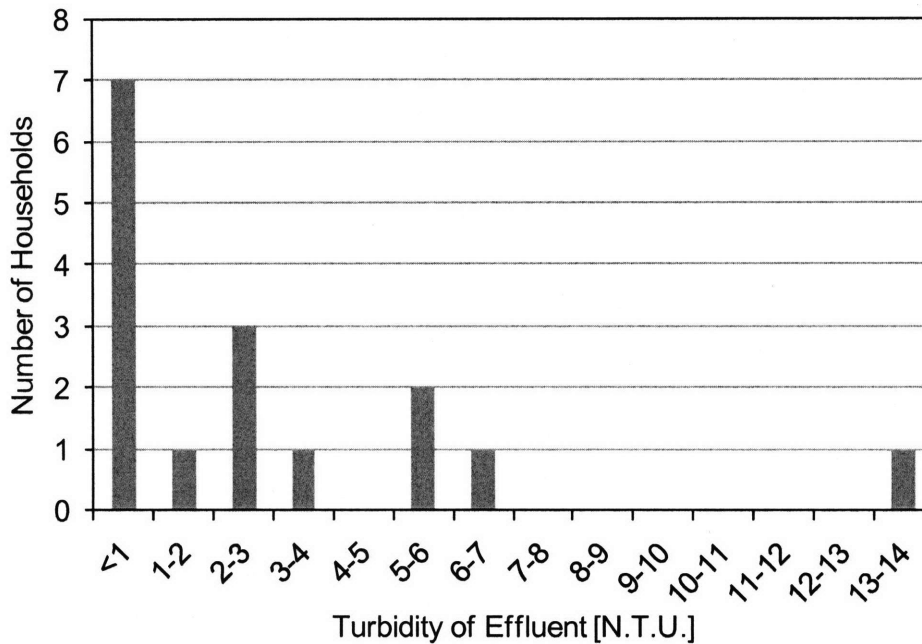

Figure 6-11 Histogram of Turbidity of Effluent for HydrAid BSFs

The histogram of the percent removal of turbidity is shown in Figure 6-12. The overall average was 87 %. However, 56 % of the results have shown turbidity removal of above 90 %.

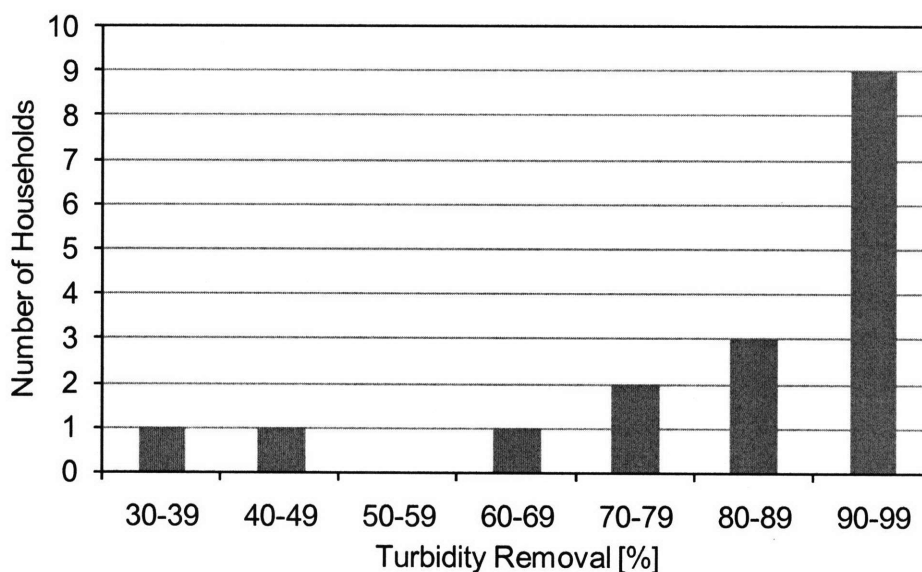

Figure 6-12 Histogram of Turbidity Removal for HydrAid BSFs

6.5.3 Microbial Testing

Total Coliform

Seven water samples were taken from the dugout. The total coliform concentration ranged from 3000 cfu/100 ml to 46,000 cfu/100 ml, with an average of 20,000 cfu/100 ml.

Twenty-two BSFs were sampled for both the inlet and outlet of the BSF. Total coliform was detected in every sample from the inlet. The total coliform colonies counted in \log_{10} units for the influent and effluent is shown in Figure 6-13. The bar graph in lighter shade represents the influent concentration, and the darker shaded bar represents the effluent concentration. Therefore, the difference between the two bars equals the \log_{10} removal of total coliform. The first bar on the left represents a sample with an influent total coliform concentration of 130,000 cfu/100 ml and an effluent concentration 1 cfu/100 ml tested with the membrane filtration method, indicating a 5.1 \log_{10} unit reduction.

The total coliform percent removal is shown in Figure 6-14. The household numbers correspond between Figure 6-13 and Figure 6-14, so you can compare both the influent/effluent concentration and the percent removal at the same time. However, it should be noted that the household numbers for Figure 6-13 and Figure 6-14 do not correspond to the household numbers in Figure 6-8 and Figure 6-9. The histogram of total coliform removal calculated by differences in \log_{10} units are shown in Figure 6-15. The overall average removal was 95 % (1.9 \log_{10} units). The average influent and effluent was 31,000 cfu/100 ml and 710 cfu/100 ml, respectively.

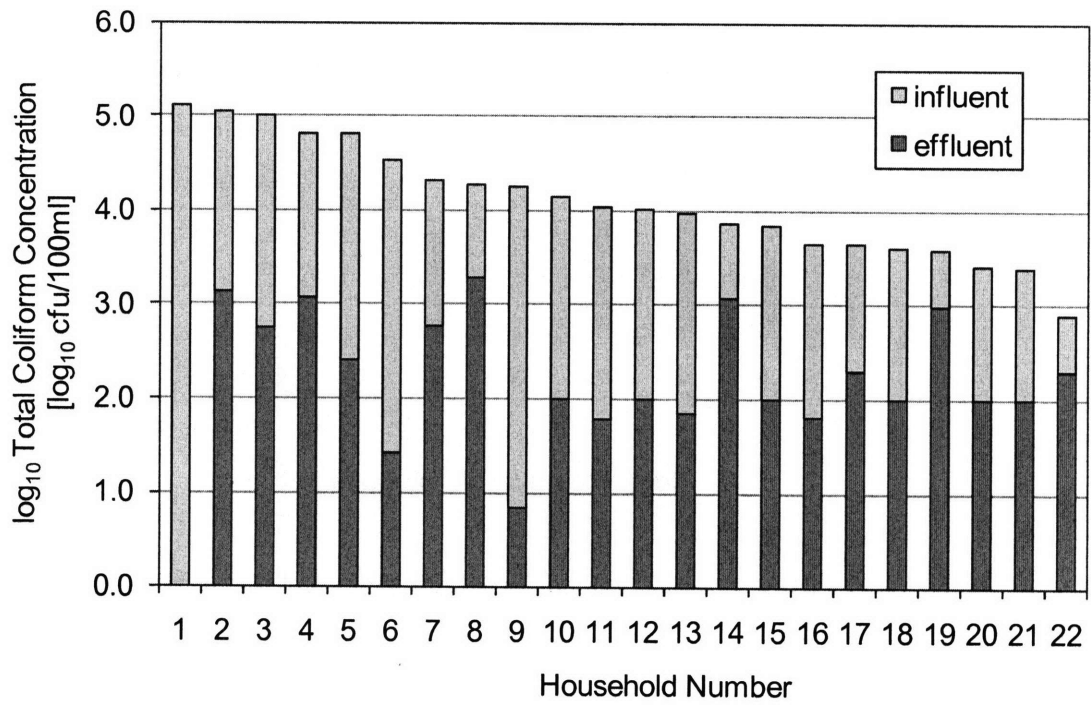

Figure 6-13 Total Coliform Concentration of Influent/Effluent of HydrAid BSFs

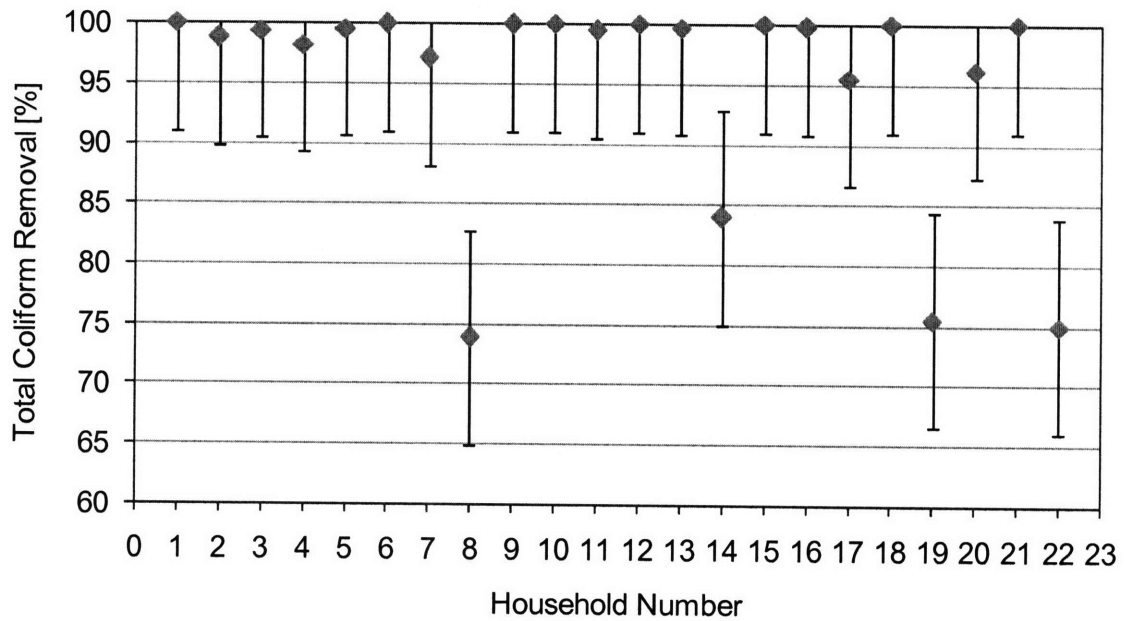

Figure 6-14 Total Coliform Percent Removal for HydrAid BSFs in Kpanvo

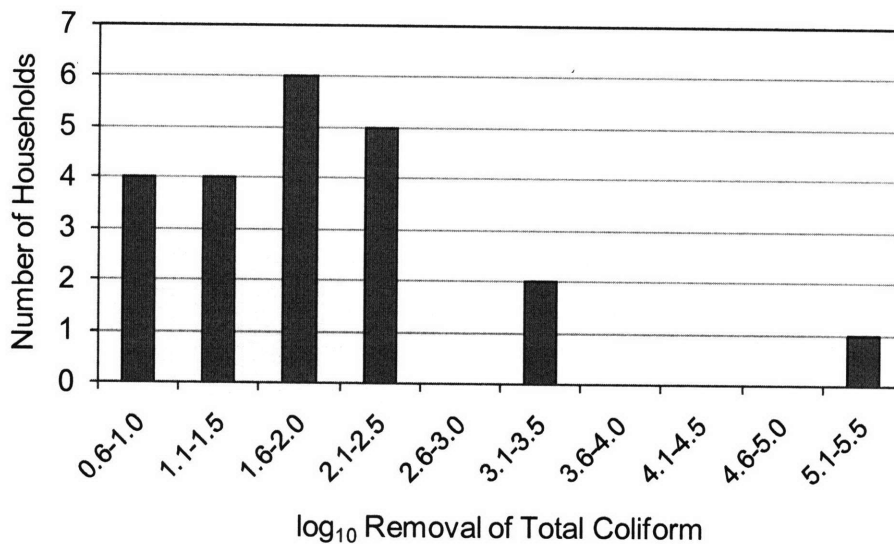

Figure 6-15 Histogram of Total Coliform Log₁₀Removal for HydrAid BSFs

E.coli

For the seven samples from the dugout, *E. coli* was only detected in one sample and the value was 10,000 cfu/100 ml (Appendix B).

Twenty-two BSFs were sampled for both the inlet and outlet of the BSF. *E. coli* was detected in nine samples out of the 22 samples. The average *E. coli* concentration of these nine samples is 960 cfu/100 ml. Out of these nine samples, no *E. coli* colonies were detected from the outlet of the HydrAid BSF. By calculating the 0 count/plate results in the 3M Petrifilm method as 100 cfu/100 ml, the average percent reduction of *E. coli* within these nine samples was 55 %. The overall average *E. coli* concentration for all samples, including the samples in which *E. coli* was not detected, will be presented in Section 6.5.4.

6.5.4 Average Turbidity and Microbial Testing Results

The average turbidity, *E. coli*/total coliform concentrations at different stages of treatment will be discussed in this section. The stages are Kpanvo Dam, the pre-treated stored water, the post-treated water from the HydrAid BSFs, and the post-treated stored water unit below the HydrAid BSFs.

The average turbidity at different treatment stages are shown in Figure 6-16. The turbidity value declines from 85 NTU to 2.9 NTU through the three stages of the dugout, pre-treated stored water, and post-treated water from the HydrAid BSF. The turbidity increases slightly to 3.0 NTU at the post-treatment storage unit.

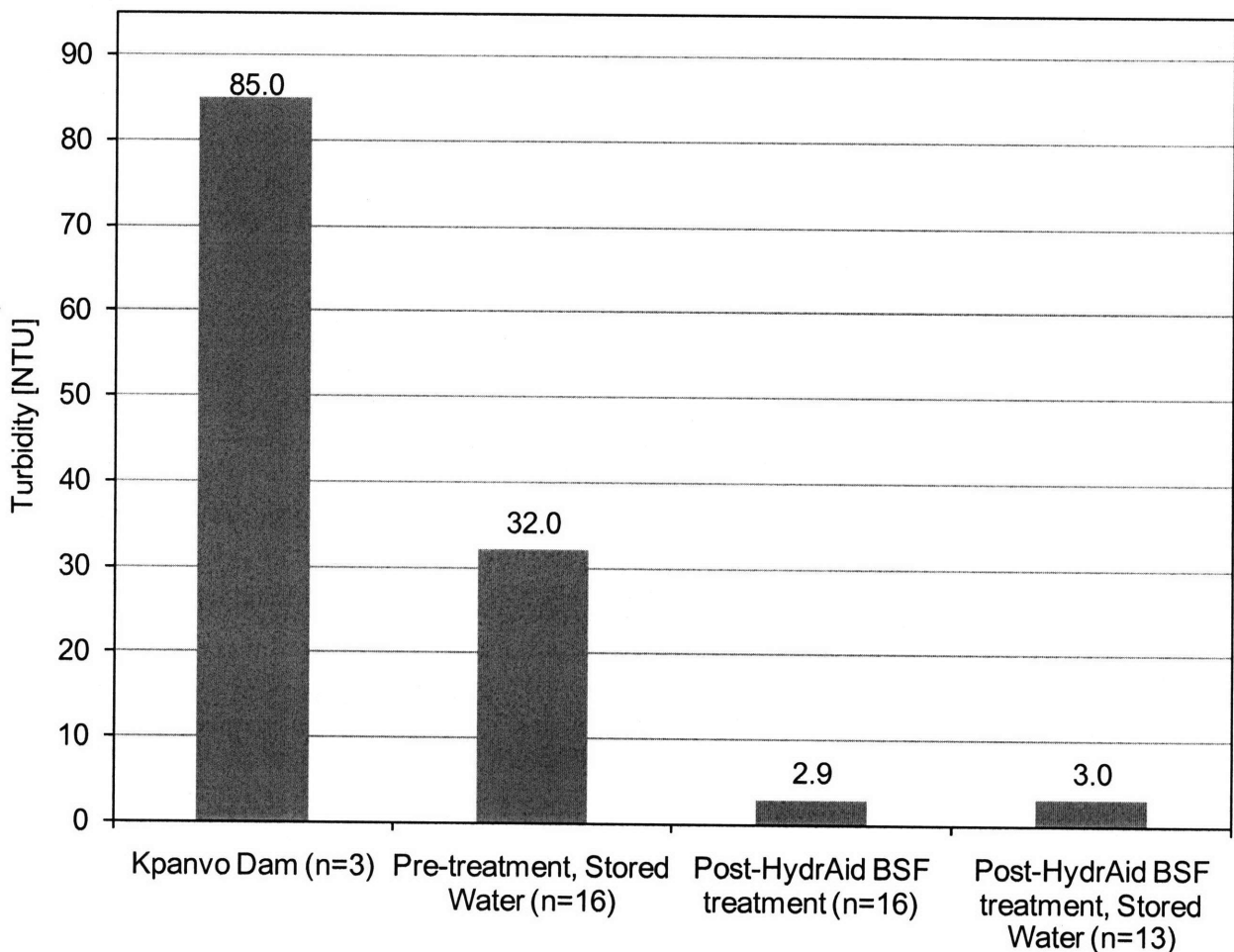

Figure 6-16 Average Turbidity Values at Different Stages of Treatment

The average *E. coli* concentration at different treatment stages are shown in Figure 6-17. The *E. coli* concentration declines from 14,000 cfu/100 ml at the dugout to 0.27 cfu/100 ml at the post-treatment stage. The percent reduction from the pre-treatment to post-treatment is 99.9 % (370 cfu/100 ml to 0.27 cfu/100 ml). However, the *E. coli* concentration slightly increases to 7.7

cfu/100 ml within the storage unit located below the HydrAid BSF. It should be noted that, as discussed in the previous section, *E. coli* was detected in limited numbers of samples. However, the average is taken from all samples including the samples in which *E. coli* was not detected. For the dugout, *E. coli* was detected in only one sample out of the seven samples.

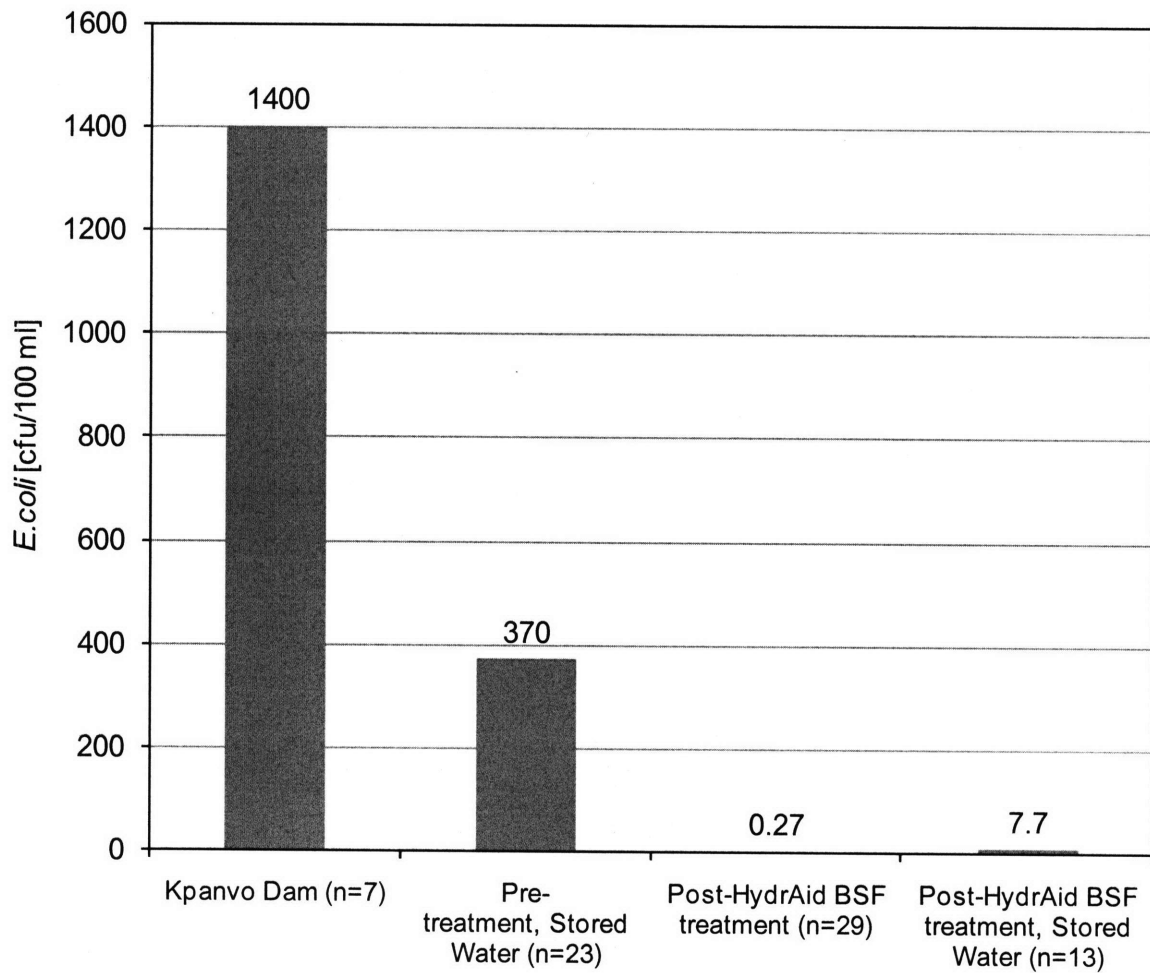

Figure 6-17 Average *E. coli* Concentrations at Different Stages of Treatment

The average total coliform concentrations at different stages of treatment are shown in Figure 6-18. The total coliform concentration increases from 20,000 cfu/100 ml at the dugout, to 31,000 cfu/100 ml at the pre-treatment storage unit. The total coliform concentration declines to 530 cfu/100 ml at the post-treatment storage unit.

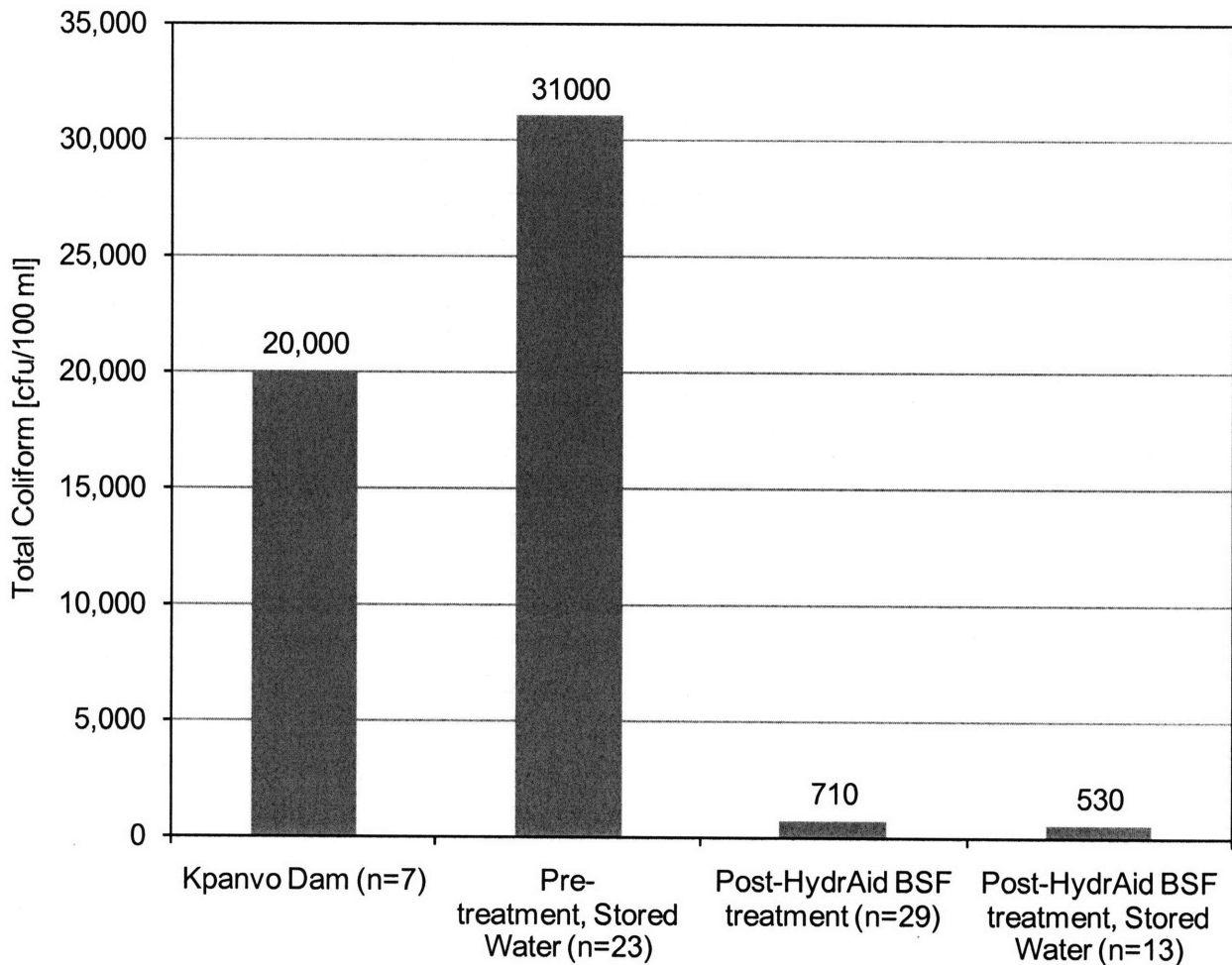

Figure 6-18 Average Total Coliform Concentrations at Different Stages of Treatment

6.6 Discussion

Flow Rate

The measured flow rates of the HydrAid BSFs were slower than the design flow rate of 47 L/hr. However, this is understandable since the flow rates were not measured at maximum head. Ngai et al. (2006) sets the minimum design flow rate of the locally constructed BSF as 5 L/hr, and recommends cleaning or inspection of the filter if the flow rate is slower than the minimum design flow rate. While most villagers of the household that were visited in Kpanvo had expressed that they clean their BSFs once in every 3 days, every HydrAid BSF that was measured had flow rates higher than 5 L/hr. Therefore, observed in January, 2008, after these filters have been in operation for one month, clogging does not seem to be problematic under the operating conditions.

Turbidity

The HydrAid BSFs have shown effective turbidity removal with an average of 87 % reduction. In Figure 6-9, there is one data point showing a turbidity removal of 32 %. However, the data point in Figure 6-8 that corresponds to this 32 % removal shows the influent and effluent turbidity to be 7.5 NTU and 5.0 NTU, respectively. Since the influent turbidity was already low, it is understandable that the removal percentage is also low. Without this data point, the turbidity removal of all the other HydrAid BSFs is above 65 %.

However, it must be noted that the influent turbidity (average 32 NTU) was not extremely high. While lower turbidity in the influent water is highly desirable, it is not representative of typical field conditions of many other dugouts in Northern Region, Ghana. In order to truly assess the capability of treating highly turbid water, further field or laboratory experiments with representative turbidity influent water is recommended.

The turbidity reduction through different stages of the treatment has been shown in Figure 6-16. The influent turbidity (average 32 NTU) is lower than the average turbidity of the dugout (85 NTU) due to effects of sedimentation within the pre-treatment storage vessel. The turbidity is successfully reduced to an average of 2.9 NTU through the HydrAid BSF treatment. The turbidity slightly increases to 3.0 NTU in the post-treatment storage unit. However, this increase is a substantially small value, and it can be concluded that the turbidity did not increase within the post-treatment storage unit.

Total Coliform

The HydrAid BSFs have also shown effective reduction of total coliform colonies with an overall average of 95 % reduction. However, the average effluent concentration of 710 cfu/100ml is significantly higher than guideline levels set by WHO (0 cfu/100ml) (WHO, 2006).

Although the total coliform reduction of the HydrAid treatment is effective, it is concerning that the total coliform concentration increases within the pre-treatment storage vessel, as shown in Figure 6-18. This indicates that bacteria are breeding within the storage vessel. The average total coliform concentration declines from 710 cfu/100ml to 530 cfu/100ml within the post-treatment storage unit.

E.coli

The *E. coli* results are not as straightforward as the total coliform results since *E. coli* was not detected in a substantial proportion of the samples. In the influent samples that *E. coli* was detected, the average concentration was 960 cfu/100 ml. This was reduced to an average of <100 cfu/100 ml through the HydrAid treatment (55 % reduction). Although the percent reduction is not high, *E. coli* was reduced to an undetectable limit.

The overall average concentration with the undetected samples included into calculation, were shown in Figure 6-17. Again, this result is not as reliable as the total coliform result due to the many samples in which *E. coli* was not detected. However, the figure shows a good trend of the *E. coli* reduction through the treatment process. The *E. coli* concentration increases slightly within the post-treatment storage from 0.27 cfu/100 ml to 7.7 cfu/100 ml, which is not a substantial increase considering the fact of that *E. coli* was not detected in many samples.

6.7 Conclusions

Out of the 200 HydrAid BSFs that were installed in Kpanvo village (Tamale district, Ghana), 30 HydrAid BSFs were tested for flow rate, turbidity, and *E.coli*/total coliform, one month after installation. The average flow rate (17 L/hr) was slower than the design flow rate (47 L/hr). However, the flow rate was not measured with a maximum head. The HydrAid BSFs have shown effective removal of turbidity (average 87 % reduction) and total coliform (average 95 % reduction). The average *E. coli* concentration was reduced by 99.9 % through the HydrAid treatment. However, this value is not as reliable as the other values, since *E. coli* was not detected in a substantial number of samples.

The turbidity and total coliform concentration slightly increased within the post-treatment storage unit, but the value was not substantial.

7 Comparison of Local Plastic Design BSFs, HydrAid BSFs and Other BSF Designs

A comparison of four BSF designs are shown in Table 7-1: the Concrete Rectangular BSF, Plastic Davnor BSF, modified/unmodified LDP BSF, and the HydrAid BSF. While the Concrete BSF and the LDP BSFs have approximately the same container volume, the Plastic Davnor BSF has a smaller volume, and the HydrAid BSF has the largest container volume. The LPD BSFs and the HydrAid BSFs have larger cross sectional area compared to the other two conventional BSFs. Increasing the cross sectional area enables treatment of larger capacity of water at the same time required. For the sand depth, the LDP BSF has a very small sand depth, but the other designs share a similar value. The LDP BSF also shows a slow surface loading rate compared to the other designs.

Table 7-1 Comparison of Four BSF Designs

	Container Volume (L)	Average Cross section area (cm ²)	Sand Depth (cm)	Maximum Water Standing Depth (cm)	Surface Loading Rate (m ³ /m ² /hr)	Design Flow Rate (L/hr)
Concrete BSF	47	512	46	34	0.23-0.70	12-36
Plastic Davnor BSF	24	258	* 42 ± 2	* 22	0.78	20
Unmodified LDP BSF	50	1088	18	* 25	0.27	** 29
Modified LDP BSF	50	1088	18 (+5, +10)	* 25	0.19	** 21
HydrAid BSF	65	905	43	22	0.52	47

* Estimated values

** Average Flow Rate results from Chapter 5

Table 7-2 shows a comparison of the LPD BSFs discussed in Chapter 5, and the HydrAid BSFs discussed in Chapter 6. Since these BSFs are different models operated under different conditions, the comparison is not straightforward.

First, the design flow rates of the two models are different. The measured flow rate is faster for the locally constructed BSF since the flow rate was measured at maximum head, and the HydrAid BSFs were not. The operation conditions were also different. The LDP BSFs were fed water one time every day, whereas the HydrAid BSFs were in regular use. This variable alone could have a large impact on the results.

Table 7-2 Comparison of LPD BSFs and HydrAid BSFs

		Locally Constructed BSFs		HydrAid BSFs
		unmodified;	modified	
Design Flow Rate		15-20 L/hr		47 L/hr
Measured Flow Rate		29 L/hr; 21 L/hr		17 L/hr *
Turbidity	influent	227 TU		32 NTU
	effluent	16 TU; 11 TU		2.9 NTU
	removal	93 %; 95 %		87%
Total Coliform	influent	15,000 cfu/100ml		20,000 cfu/100ml
	effluent	430 cfu/100 ml **		710 cfu/100ml
	removal	87 % **		95%
Cost		\$ 16 - \$ 25		\$ 50 - \$ 65

* Not measured at maximum head

** Average values on Day 11

*** Average value after 30+ days of operation

Both models have shown effective removal of turbidity. The locally constructed BSFs show higher removal percentages, which could be due to the fact that the influent turbidity is much higher. Nonetheless, the effluent turbidity concentration difference between of the two designs is not large.

Interestingly, although the influent water for the HydrAid BSFs had a lower value for turbidity, the total coliform concentration is higher. While the HydrAid BSF has shown effective removal of total coliform, these results were unable to be obtained for the LPD BSFs. However, the removal percentage and effluent quality on Day 11 of the LDP BSFs (estimated to be 1-2 days before the filter ripening was complete) is relatively good. In fact, the total coliform concentration of effluent is lower than the effluent from the HydrAid BSFs. The percent removal of total coliform is greater for the HydrAid BSFs (95 %) compared to the LDP BSFs (87 %).

8 Summary and Conclusions

Two unmodified local plastic design (LPD) BSFs and two modified LPD BSFs were constructed and operated in Northern Region, Ghana. The treatment efficacy of the modified and unmodified LPD BSFs was evaluated in this research.

Modifications of the LPD BSFs were made in order to provide an additional “biolayer,” the core layer of a BSF where most removal and degradation of pathogens occur. This was carried out by having one LPD BSF with an additional sand layer of 5 cm, and one LPD BSF with an additional sand layer of 10 cm. All four BSFs showed effective removal of turbidity with an average removal of 92-95 %. However, the turbidity removal of the standard BSFs declined after 27 days of operation. There was no decline in the modified BSFs. This could possibly be an indication of the enhanced capacity of the modified BSFs, either having longer filter life (less frequent cleaning), or the ability to withstand greater operational variation. Total coliform data for the locally constructed BSFs was not obtained on a daily basis due to time/resource constraints. However, the total coliform removal on Day 11 (estimated to be 1-2 days before the filter ripening was complete) is relatively good with an average of 87 % removal and an average effluent concentration of 430 cfu/100 ml from an influent concentration of 15,000 cfu/100 ml. *E. coli* colonies were not detected in the majority of the influent/effluent samples of the LPD BSFs.

Out of 200 HydrAid BSFs that were concurrently installed in Kpanvo village, 30 HydrAid BSFs were evaluated. These HydrAid BSFs showed an average of 87 % removal turbidity, and an average of 95 % removal of total coliform. *E. coli* was not detected in a substantial number of samples for the HydrAid BSFs, but an overall average reduction of 99 % was observed. However, the influent turbidity was not extremely high (average of 32 NTU). Therefore, further research, such as testing the BSFs with water with higher turbidity, is recommended to evaluate the true efficacy of the HydrAid BSF.

The total coliform concentration of the filtrate of the LPD BSFs was 430 cfu/100 ml (on Day 11), which was a lower value than that of the internationally imported HydrAid BSFs (710 cfu/100 ml). However, both these values are well above the guideline value set by WHO. Therefore, an additional water treatment step to disinfect post-BSF filtered water is highly recommended.

9 References

- American Water Works Association. (1991). *Manual of Design for Slow Sand Filtration*. Denver: Hendricks, D. (Ed.).
- BBC Weather. (2006). *BBC Weather; Tamale, Ghana*. Retrieved April 17, 2008 from http://www.bbc.co.uk/weather/world/city_guides/results.shtml?tt=TT000250
- Buzunis, B. (1995). Intermittently Operated Slow Sand Filtration, Unpublished Master's of Engineering, The University of Calgary, Calgary, Canada
- Center for Affordable Water and Sanitation Technology (CAWST). (2006). *Steel Mold Fabrication Instructions; For Concrete BioSand Filter, Filter Version 9.0*.
- Center for Affordable Water and Sanitation Technology (CAWST). (2008). *Biosand Filter Manual, Design, Construction, Installation, Operation, and Maintenance*.
- Center for Affordable Water and Sanitation Technology (CAWST). *Household Water Treatment*. Retrieved March 30, 2008 from <http://www.cawst.org/index.php?id=128#BSF>
- Central Intelligence Agency (CIA). (15 April, 2008). *CIA - The World Factbook - Ghana*. Retrieved April 17, 2008 from <https://www.cia.gov/library/publications/the-world-factbook/geos/gh.html>
- Clearinghouse, for Low-cost Household Water Treatment Technologies. Retrieved March 30, 2008 from <http://www.jalmandir.com/>
- Di Bernardo, L., Rivera, A. E. (1996). Influence of Sand Uniformity Coefficient on Slow Sand Filtration Performance. In N. Graham & R. Collins (Eds.), *Advances in Slow Sand Filtration and Alternative Biological Filtration* (pp. 233-243). West Sussex, England: John Wiley & Sons Ltd.
- Donison, K. S. (2004). *Household Scale Slow Sand Filtration in the Dominican Republic*. Master's of Engineering, Civil and Environmental Engineering Department, Massachusetts Institute of Technology, Cambridge, MA. Available at <http://web.mit.edu/watsan/> > Documents > Students Thesis > Dominican
- Earwaker, P. (2006). *Evaluation of Household Biosand Filters in Ethiopia*. Unpublished Master's of Science in Water Management, Cranfield University, Silsoe.

- Esrey, S. A., Feachem, R. G., & Hughes, J. M. (1985). Interventions for the control of diarrhoeal diseases among young children: improving water supplies and excreta disposal facilities. *Bull World Health Organ*, 63(4), 757-772.
- Fewtrell, L., & Colford, J. M. J. (2004). *Water, Sanitation and Hygiene: Interventions and Diarrhoea*. Washington, DC: The International Bank for Reconstruction and Development/ The World Bank.
- Foran, M. (2007). *An Analysis of the Time to Disinfection and the Source Water and Environmental Challenges to Implementing a Solar Disinfection Technology (SolAgua)*. Unpublished Masters' Thesis, Department of Population and International Health, Harvard School of Public Health. Boston.
- Gordon, Raymond G., Jr. (ed.), 2005. *Ethnologue: Languages of the World, Fifteenth edition*. Dallas, Tex.: SIL International. Retrieved May 17, 2008 from <http://www.ethnologue.com/>
- Graham, N. J. D., Clarke, B. A., Jones, C. J., Lloyd, B. J. (1996). Effect of Reduced Depth, Fabric-Protected Slow Sand Filters on Treated Water Quality. In N. Graham & R. Collins (Eds.), *Advances in Slow Sand Filtration and Alternative Biological Filtration* (pp. 233-243). West Sussex, England: John Wiley & Sons Ltd.
- Galvis, G. (1999). *Development and Evaluation of Multistage Filtration Plants; An Innovative, Robust and Efficient Water Treatment Technology*. Unpublished Doctor of Philosophy, University of Surrey, United Kingdom, Guildford.
- Huisman, L. and Wood, W. E. (1974). *Slow Sand Filtration*. World Health Organization, Geneva
- International Aid. (2007). *Initiative; Safe Water; HydrAid Biosand Water Filter*. Retrieved April 20, 2008 from http://www.internationalaid.org/initiatives/safe_water.php
- Johnson, S. (2007). *Health and Water Quality Monitoring of Pure Home Water's Ceramic Filter Dissemination in the Northern Region of Ghana*. Master of Engineering Thesis. Civil and Environmental Engineering Department, Massachusetts Institute of Technology, Cambridge, MA.
Available at <http://web.mit.edu/watsan/> > Documents > Students Thesis > Ghana
- Lee, T. L. (2001). *Biosand Household Water Filter Project in Nepal*. Master of Engineering Thesis. Civil and Environmental Engineering Department, Massachusetts Institute of Technology, Cambridge, MA.

Available at <http://web.mit.edu/watsan/> > Documents > Students Thesis > Nepal

Losleben, T. R. (2008). *Pilot Study of Horizontal Roughing Filtration in Northern Ghana as Pretreatment for Highly Turbid Dugout Water*. Master of Engineering Thesis. Civil and Environmental Engineering Department, Massachusetts Institute of Technology, Cambridge, MA.

Available at <http://web.mit.edu/watsan/> > Documents > Students Thesis > Ghana

Lukacs, H. A. (2002). *From Design to Implementation: Innovative Slow Sand Filtration for Use in Developing Countries*. Master of Engineering Thesis. Civil and Environmental Engineering Department, Massachusetts Institute of Technology, Cambridge, MA.

Available at <http://web.mit.edu/watsan/> > Documents > Students Thesis > Nepal

Massachusetts Institute of Technology. (2006). *Construction, Installation, & Trouble-shooting of the Biosand Filter*. Tamale, Ghana: Murcott.

Murcott, S., Johnson, S., Foran, M., Yazdani, I., & Doyle, K. (2007). *Water Quality of Dugout Water in Northern Region Ghana and Methods to Reduce Turbidity, Microbes and Guinea Worm*. Unpublished Internal Report, Massachusetts Institute of Technology, Cambridge, MA.

Murcott, S. (2008). *Biosand Filter Fact Sheet. Household Water Treatment and Safe Storage (HWTS) Product and Implementation Fact Sheet*.

Nichols, D. (2007). Biosand Filters Presentation given at Rotary International Conference (June 17-20, 2007). Salt Lake City, Utah

Ngai, T., Walewijk, S. (2003). *The Arsenic Biosand Filter (ABF) Project: Design of an Appropriated Household Drinking Water Filter for Rural Nepal*. Retrieved April 20, 2008 from <http://web.mit.edu/watsan/Docs/Other%20Documents/KAF/NgaiWalewijk-%20ABF%20Report2003.pdf>

Ngai, T., Murcott, S., Dangol, B. (2006a). *Construction, Installation, Operation, and Troubleshooting of Kanchan™ Arsenic Filter (KAF) Gem505 Version*. Presentation at the Kanchan™ Arsenic Filter Local Entrepreneur's Training Workshop on January 16-20, 2006. Kathmandu, Nepal.

Ngai, T., Dangol, B., Murcott, S., Shrestha, R. R. (2006b). *Kanchan Arsenic Filter*. Massachusetts Institute of Technology (MIT) and Environment and Public Health Organization (ENPHO). Kathmandu, Nepal.

- Paramasivam, R., Joshi, N. S., Dhage, S. S. & Tajne, D. S. (1980). Effect of Intermittent Operation of Slow Sand Filters on Filtered Water Quality, *Indian Journal of Environmental Health*, 22(2)136-150.
- Palmateer, G., Manz, D., & Jurkovic, A. (1999). Toxicant and Parasite Challenge of Manz Intermittent Slow Sand Filter. *Environmental Toxicology*, 14, 217-225.
- Samaritan's Purse Canada Website. Biosand Water Filter. Retrieved March 25, 2008 from http://www.samaritanspurse.ca/ourwork/water/biosandfilter_general.aspx
- Schulz, C. R. & Okun, D. A. (1984). *Surface Water Treatment for Communities in Developing Countries*. John Wiley & Sons, New York.
- Sobsey, M. D. (2002). *Managing Water in the Home: Accelerated Health Gains from Improved Water Supply*. World Health Organization, Geneva.
- Stauber, C. E., Elliott, M. A., Koksai, F., Ortiz, G. M., DiGiano, F. A., & Sobsey, M. D. (2006). Characterization of the Biosand Filter for E. coli Reductions from Household Drinking Water under Controlled Laboratory and Field Use Conditions. *Water Science & Technology*, 54 (3), 1-7.
- Stauber, C. E. (2007). *The Microbiological and Health Impact of the Biosand Filter in the Dominican Republic: A Randomized Controlled Trial in Bonao*. Unpublished Doctor of Philosophy, University of North Carolina at Chapel Hill, Chapel Hill.
- United Nations. (2005). *UN Millennium Development Goals*. Retrieved March 30, 2008 from <http://www.un.org/millenniumgoals/>
- Van der Hoek, J. P., Bonne, P. A. C., Kors, L. J., Te Welscher, T. A. G. (1996). Slow Sand Filtration: Effect of Grain Size and Filtration Rate on Operation and Performance. In N. Graham & R. Collins (Eds.), *Advances in Slow Sand Filtration and Alternative Biological Filtration* (pp. 233-243). West Sussex, England: John Wiley & Sons Ltd.
- Visscher, J. T., Paramasivam, R., Raman, A. & Heijnene, H. A. (1987). *Slow Sand Filtration for Community Water Supply*. International Water and Sanitation Center, The Hague.
- Weber-Shirk, M. L. & Dick, R. I. (1999). Bacterivory by a Chrysophyte in Slow Sand Filters. *Wat. Res*, 33 (3), 631-638
- World Health Organization and United Nations Children's Fund. (2004). *Meeting the MDG*

Drinking Water and Sanitation Target, A Mid-term Assessment of Progress. Retrieved March 30, 2008 from http://www.unicef.org/wes/files/who_unicef_watsan_midterm_rev.pdf

World Health Organization and United Nations Children's Fund. (2006). *Meeting the MDG Drinking Water and Sanitation Target : The Urban and Rural Challenge of the Decade.* Retrieved March 30, 2008 from http://www.wssinfo.org/pdf/JMP_06.pdf

World Health Organization. (2006). *Guidelines for Drinking-water Quality First Addendum to 3rd ed.* World Health Organization, Geneva.
Available at http://www.who.int/water_sanitation_health/dwq/gdwq0506.pdf

Appendix A Summary of Peer-Reviewed and Grey Literature on BSFs

(Source: Stauber, 2007)

Reference	Summary of Study	Average Reduction (Sample Size)
(Manz et al., 1993) Field study in Nicaragua	Four BSFs installed and sampled two months later.	99.5% for fecal coliforms (n = 3)
(Buzunis, 1995) Laboratory study in Canada	Tested filter for 2.5 months: dosed daily with environmentally contaminated surface water.	96% (range 99.7-91.1%) for fecal coliforms during sampling on days 10-42.
(Sattar, 1998) Laboratory study in Canada	Filter dosed with 60 L of water with high algal content: then dosed for 28 days with 20 L of untreated surface water. Hepatitis A virus dosed onto filter: other bacteria measured were naturally occurring.	89.8% for total coliforms (n= 4) 87.4% for fecal coliforms (n = 4) 66 % for Hepatitis A virus (n = 3)
(Palmateer et al., 1999) Laboratory study in Canada	Filters dosed with surface waters until biofilm formed (~ two weeks). Chemicals and microorganisms were dosed. One-time dose of 10^6 <i>Cryptosporidium</i> and 10^5 <i>Giardia</i> then sampled. Naturally occurring bacteria measured.	>99.999% for <i>Giardia</i> (n=1) 99.98% for <i>Cryptosporidium</i> (n=1) 83% for heterotrophic plate counts bacteria (n = 5) 50-99% reduction of organic and inorganic chemicals

(Kaiser & Chang, 1998) Field study in Vietnam	100 filters installed in Ha Tay province in the community of Lai Yen.	95.8% for fecal coliforms (n= 38)
(Snider, 1998) Field study in Western Kenya	25 filters installed in Londiani, Western Kenya	93% for <i>E. coli</i> (n = 25)
(Lee, 2001) Field study in Nepal, Laboratory study at MIT	39 filters sampled in Nepal. In laboratory at MIT, BSF studied for 2 months. Filter dosed daily for 45 days with 20 L surface water prior to sampling. Naturally occurring bacteria sampled.	99.5% for fecal coliforms in laboratory study (n=5)
(Mol, 2001) Field study in Kenya	110 filters installed in Machakos District in Eastern Kenya.	93% <i>E. coli</i> (n=110)
(Kaiser et al., 2002) Field study in Honduras, Nicaragua, Mozambique, Kenya, Cambodia and Vietnam	Evaluated the BSFs in six countries; tested 577 filters and interviewing users. 94.6% - 100% of users said BSF improved health of their household. 98.4% still used the filter and 88.5% on a daily basis.	93% for fecal coliforms (n=577) Honduras 100% Nicaragua 99% Mozambique 98% Kenya 94% Cambodia 83% Vietnam 81%
(Lantagne, 2004) Field visit in Dominican Republic	Visited 10 BSFs in Playa Oeste, Puerto Plata, Dominican Republic. Filtered water sampled.	Filtered water positive for total coliforms but not <i>E. coli</i> .
(Donison, 2004) Field study in the Dominican Republic and laboratory study at MIT	45 BSFs in Dominican Republic were visited. Laboratory study at MIT, filters dosed with 5 L of a 1:10 mix of waste water to river water for 29 days; sampled twice each week.	In 5 communities, 80% for total coliforms, and in two communities <0% for total coliforms. 90% <i>E. coli</i> in laboratory study (range 52-97%) (n = 7)
(Maertens & Buller, 2006) Field study in Ethiopia	> 500 filters installed in the Oromia region, Liben Woreda district, Ethiopia. 50 BSF households and 50 control households were interviewed. Filters test for bacterial reductions. Control households reported higher two week point prevalence of worms, skin infections, vomiting, and diarrhea.	98.6% for total coliforms (n=50) 97.3% <i>E. coli</i> (n=50) 85% for turbidity (n=50)

(Earwaker, 2006) Field study in Ethiopia	57 BSFs from the Oromia region Liben Woreda district of Ethiopia. 39 filters were sampled.	87.9% for <i>E. coli</i> (n=39)
(Duke et al., 2006) Field study in Haiti	107 households with BSFs installed in Artibonite Valley, Haiti were interviewed and water samples were taken. Filters had been in use for an average of 2.5 years.	98.5% for <i>E. coli</i> (n = 92) (10 samples omitted)
(Baker, 2006; CAWST, 2006) Field study in Haiti (longitudinal component of study listed in Duke et al., 2006)	80 households received BSFs and were followed for 3 months for water quality and diarrheal disease. Diarrheal disease was assessed prior to and after filter installation and compared with households who had received filters > 2 years prior. Most indicators of diarrheal disease improved after installation of filter.	76% <i>E. coli</i> (n = 80 filters but sampled repeatedly)
(Stauber et al., 2006) Field study in Dominican Republic and laboratory study at UNC	Two laboratory BSFs were dosed daily with 40 L of surface water inoculated with <i>E. coli</i> . Filters sampled over 3-6 weeks. 55 BSFs in Bonao, Dominican Republic had been installed 4-11 months prior to sampling.	94% for <i>E. coli</i> in laboratory studies. 93% for <i>E. coli</i> in filters in the field (n=55)
(Elliott et al., 2006) Laboratory study at UNC	4 experiments with daily dosing volumes of 20 or 40 L surface water inoculated with <i>E. coli</i> and viruses (coliphage and echovirus type 12).	73.6% was initial reduction for <i>E. coli</i> reduction. Improved to 97.5% after 30 days. Similar results for coliphage 69% initially then improving to 90% after 30 days. 95% for Echovirus
(CAWST) Summary of all lab and field tests (website)*	-Family Bible Fellowship in Guatemala and El Salvador. 31 field tests performed in 2002. -Global outreach student's association in Guatemala in 2001. -Biosand water filter project in Nicaragua in 1999 -Samaritan's Purse in Brazil in 1998	-83.1% for <i>E. coli</i> . 89.16% for coliforms (n=31) -99.6% for coliforms (n=3) -79.9% for fecal coliforms (64.4-95.0%) -99.7% for fecal coliforms. 98.64% for <i>E. coli</i> (n=55)

Appendix B Raw Data

Local Plastic Design BSFs (Microbial Testing)

Sample #	Date	Day	name	results from no dilution samples		results from 1:10 dilutions (3M Petrifilm)		ultimate concentration	
				E.Coli CFU/100 ml	Total CFU/100 ml	E.Coli CFU/100 ml	Total CFU/100 ml	E.Coli CFU/100 ml	Total CFU/100 ml
1	1/20	7	Dugout			0	3000	0	3000
2	1/20	7	BSF A	0	2600	0	4000	0	2600
3	1/20	7	BSF A'	0	TTNC	0	47000	0	47000
4	1/20	7	BSF B	400	3600	0	4000	400	3600
5	1/20	7	BSF C	0	1700	0	2000	0	1700
6	1/21	8	Dugout	0	TTNC	0	50000	0	50000
7	1/21	8	BSF A	0	1500	0	3000	0	1500
8	1/21	8	BSF A'	0	3200	0	4000	0	3200
9	1/21	8	BSF B	100	700	0	1000	100	700
10	1/21	8	BSF C	0	1800	0	4000	0	1800
11	1/22	9	Dugout			0	1000	0	1000
12	1/22	9	BSF A	0	800			0	800
13	1/22	9	BSF A'	0	2000			0	2000
14	1/22	9	BSF B	0	500			0	500
15	1/22	9	BSF C	0	2200			0	2200
16	1/23	10	Dugout	0	4100	0	22000	0	4100
17	1/23	10	BSF A	0	700			0	700
18	1/23	10	BSF A'	0	2300			0	2300
19	1/23	10	BSF B	0	800			0	800
20	1/23	10	BSF C	0	800			0	800
21	1/24	11	Dugout	100	3000	0	1000	100	3000
22	1/24	11	BSF A	0	300			0	300
23	1/24	11	BSF A'	0	500			0	500
24	1/24	11	BSF B	0	600			0	600
25	1/24	11	BSF C	0	300			0	300

* The detection limit of 3M Petrifilms is 100 CFU/100 ml. Therefore, for calculations of coliform removal, samples with no counts of colonies are calculated as < 100 CFU/ 100 ml

Selected Value

** For samples that were tested with both no dilution and 1:10 dilution, the result was selected based on the number of counts/plate. Counts/plate can be obtained by dividing the no dilution samples and 1:10 dilution samples by 100 and 1000, respectively.

Local Plastic Design BSFs (Flow Rate and Turbidity)

DATE	Day	Flow Rate (L/hr)				Turbidity (TU & NTU)				
		BSF A	BSF A'	BSF B	BSF C	BSF A	BSF A'	BSF B	BSF C	Dam
1/13	0	28.2	18.0	33.6	25.8					
1/14	1	36.9	24.3	44.8	34.3					
1/17	4	27.1	32.7	16.6	15.7					
						[NTU]				
1/20	7	32.7	26.7	18.5	25.7	71.7	27.5	42.8	28.9	301
1/21	8	32.7	24.0	21.2	17.1	73.4	71.1	68.8	52.7	176
1/22	9	32.7	25.7	27.7	24.0	87.3	77.2	88.1	64.9	193
1/23	10	37.2	24.5	23.5	15.0	89.8	80.1	75.2	64.5	192
1/24	11					87.4	83.9	87.9	67.3	175
1/25	12	34.5	26.1	27.9	30.4					
						[TU]				
1/26	13	26.8	26.7	25.1	23.9	10	10	10	10	150
1/28	15	26.3	26.4	26.4	25.9	10	10	10	10	200
1/29	16	29.0	24.6	23.0	19.3	10	10	10	10	150
1/30	17	31.6	28.1	21.4	22.9	10	10	10	10	150
1/31	18	31.4	19.3	23.2	20.9	10	10	10	10	200
2/1	19	30.8	26.4	16.6	20.3	10	10	10	10	180
2/2	20	32.0	28.2	26.3	21.8	10	10	10	10	180
2/3	21	37.1	25.2	19.0	19.8	10	10	10	10	220
2/4	22	36.3	22.2	17.2	21.0	10	10	10	10	200
2/5	23	33.7	27.6	16.0	18.2	10	10	10	10	250
2/6	24	35.6	33.3	18.7	19.4	10	10	10	10	350
2/7	25	33.8	33.4	17.8	23.0	10	10	10	10	200
2/8	26	36.3	24.9	22.1	23.5	10	10	10	10	400
2/9	27	35.2	30.2	21.1	24.3	10	10	10	10	400
2/10	28	32.2	28.3	16.4	20.2	15	20	10	10	250
2/13	31	35.0	28.0	15.1	18.9	20	20	10	10	200
2/14	32	32.0	28.7	16.1	19.3	20	20	10	10	200
2/15	33	38.3	29.5	18.5	21.5	40	20	10	10	200
2/16	34	34.7	28.7	16.3	20.7	50	40	10	10	150
2/17	35	33.0	31.1	17.2	18.8	50	50	10	10	200
2/18	36	36.1	34.2	16.7	23.4	10	10	10	10	190
2/20	38	25.1	19.0	25.2	16.5					
2/21	39	19.9	14.0	17.9	13.0					
2/24	42	28.7	28.6	21.2	16.3	25	13	15	10	300
2/25	43	31.8	20.8	23.8	16.7	10	10	35	15	300
2/26	44	28.0	20.6	24.8	20.3	10	10	10	10	250
2/28	45	27.7	15.6	24.3	21.6	10	10	10	10	200

10	Turbidity < 10
10	Turbidity actually equals 10

HydrAid BSFs (Microbial Testing)

For households 1 through 8, samples were tested with both the Membrane Filtration method and the 3M Petrifilm method. For these samples, cells are color code to indicate which values were selected for further analysis, such as percent reduction of *E. coli*/total coliform. The color indicates how the values were selected: (1) the fact that Membrane Filtration has a better accuracy than 3M Petrifilm, and (2) number of counts/plate. Overall, most of the results were consistent between the Membrane Filtration and 3M Petrifilm method.

Method	Date	Household #	BSF inlet		BSF outlet		Storage Unit under BSF	
			<i>E.Coli</i> CFU/100 ml	Total CFU/100 ml	<i>E.Coli</i> CFU/100 ml	Total CFU/100 ml	<i>E.Coli</i> CFU/100 ml	Total CFU/100 ml
MF	1/16	Dugout	0	10000				
MF	1/17	Dugout	10000	40000				
MF	1/21	Dugout	0	21000				
MF	1/24	Dugout	0	5000				
MF	1/27	Dugout	0	3000				
3M	1/16	Dugout	0	46000				
3M	1/19	Dugout	0	17000				
MF	1/16	1			0	0		
3M	1/16				0	0		
MF	1/17	2			0	15		
3M	1/17				0	0		
MF	1/17	3			0	10		
3M	1/17				0	0		
MF	1/18	4	0	10000	1	48	0	74
3M	1/18			0	9000	0	0	0
MF	1/18	5	0	10000	1	40		
3M	1/18			0	2100	0	0	0
MF	1/20	6	0	30000	0	7		
3M	1/19			1000	40000	0	0	0

MF	1/22	7	1000	121000	0	640		
3M	1/22		0	36000	0	100	0	900
MF	1/22	8	0	42000	0	1100		
3M	1/22		100	7000	0	3500		
3M	1/17	9			0	3800		
3M	1/17	10			0	400		
3M	1/17	11			0	2600		
3M	1/17	12			0	3100		
3M	1/18	13	700	4500	0	200	0	200
3M	1/18	14	0	2600	0	100	100	100
3M	1/18	15	0	4100	0	0	0	2100
3M	1/18	16	200	67000	0	1200	0	700
3M	1/18	17	0	7500	0	1200	0	100
3M	1/18	18	5000	116000	0	1400	0	1100
3M	1/19	19	100	7050	0	0	0	0
3M	1/19	20	0	800	0	200	0	1500
3M	1/19	21	100	10400	0	0		
3M	1/22	22	400	14000	0	0		
3M	1/22	23	0	2500	0	0		
MF	1/20	24	0	21000	6	606		
MF	1/21	25	0	100000	0	580		
MF	1/21	26	0	130000	0	1		
MF	1/24	27	0	18000	0	7	0	100
MF	1/26	28	0	4000	0	980		
MF	1/26	29	0	11000	0	60		
MF	1/27	30	0	11000				

Selected value based on the fact that Membrane filtration has a better accuracy than 3M Petrifilm

Selected value based on the number of counts/plate

HydrAid BSFs (Turbidity)

Date	Dugout & Household #	BSF inlet	BSF outlet	Storage Unit	turbidity removal [%]
		turbidity [NTU]	turbidity [NTU]	turbidity [NTU]	
1/17	Kpanvo Dam	100 (TU)			
1/19	Kpanvo Dam	85.3			
1/22	Kpanvo Dam	36.1			
1/18	4	24.3	0.4	0.52	98.4
1/18	13	60	13.1	5.01	78.2
1/18	5	16.7	5.85	4.39	65.0
1/18	14	10.9	2.77	2.51	74.6
1/18	15	28.2	0.31	2.23	98.9
1/18	16	57.9	6.73	4.46	88.4
1/18	17	19.3	2.07	2.14	89.3
1/18	18	44	3.44	6.6	92.2
1/19	6	29.6	0.58	1.59	98.0
1/19	19	29.2	0.4	0.9	98.6
1/19	20	7.46	5.01	5.15	32.8
1/19	21	32.6	0.48		98.5
1/19	22	15.7	2.74	2.4	82.5
1/22	8	44.7	0.33		99.3
1/22	24	36.9	0.48		98.7
1/22	25	38	1.19	1.49	96.9
1/22	7	40			

HydrAid BSFs (Flow Rate)

Date	Household #	flow rate [//hr]
1/17	3	17.1
1/17	10	45.0
1/17	2	15.7
1/17	11	30.0
1/17	12	18.0
1/18	4	13.3
1/18	13	11.6
1/18	5	5.1
1/18	14	25.7
1/18	15	32.7
1/18	16	7.8
1/18	17	6.0
1/18	18	20.0
1/19	6	6.5
1/19	19	15.0
1/19	20	36.0
1/19	21	25.7
1/19	22	8.6
1/22	8	17.1
1/22	24	5.9
1/22	25	6.3
1/22	7	11.6

Appendix C Construction and Installation Manual of LPD BSF

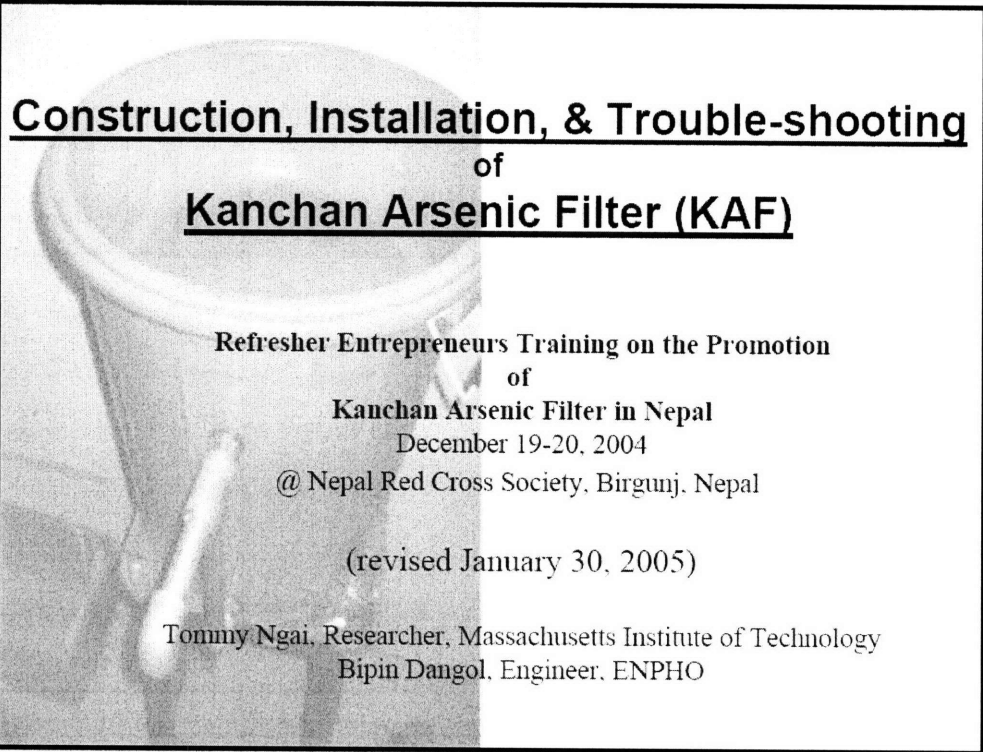

Construction, Installation, & Trouble-shooting of Kanchan Arsenic Filter (KAF)

Refresher Entrepreneurs Training on the Promotion
of

Kanchan Arsenic Filter in Nepal

December 19-20, 2004

@ Nepal Red Cross Society, Birgunj, Nepal

(revised January 30, 2005)

Tommy Ngai, Researcher, Massachusetts Institute of Technology
Bipin Dangol, Engineer, ENPHO

Presentation Outline

- Major Filter Components
- Filter Construction
- Filter Installation
- Trouble-shooting

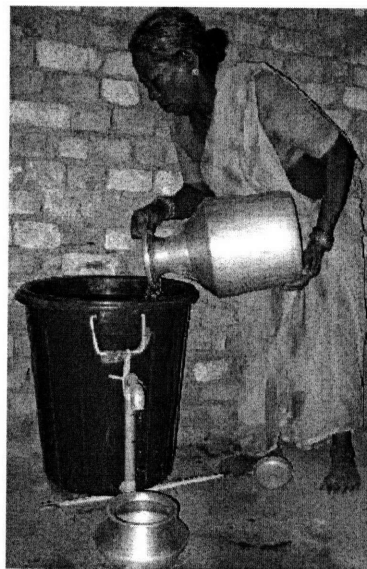

Major Filter Components

Major Filter Components

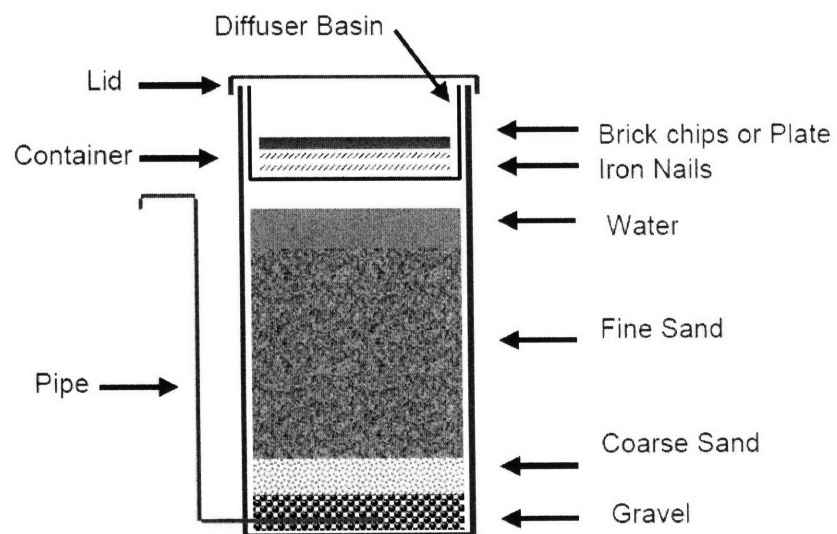

Major Filter Components

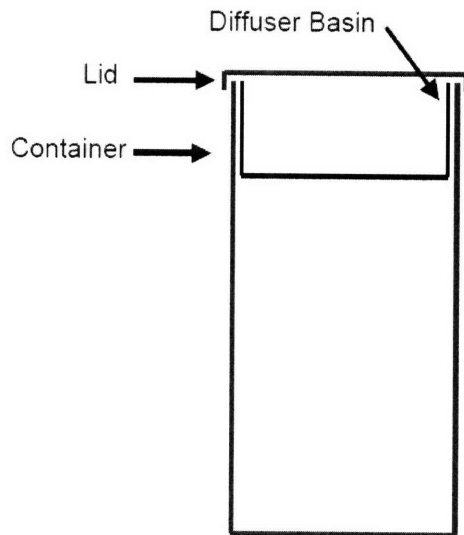

Specifications:

Container & Lid
→ Gem model 505

Diffuser Basin
→ Gem model 1700

Major Filter Components



Container & Lid
→ Gem model 505



Diffuser Basin
→ Gem model 1700

Major Filter Components

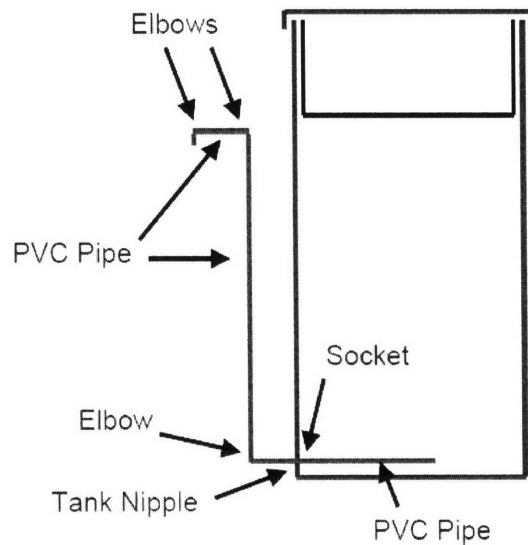

Specifications:

Pipe (PVC or GI)
→ ½ inch

Pipe fittings (PVC or GI)
→ 3 elbows
→ 1 tank nipple
→ 1 socket

Major Filter Components

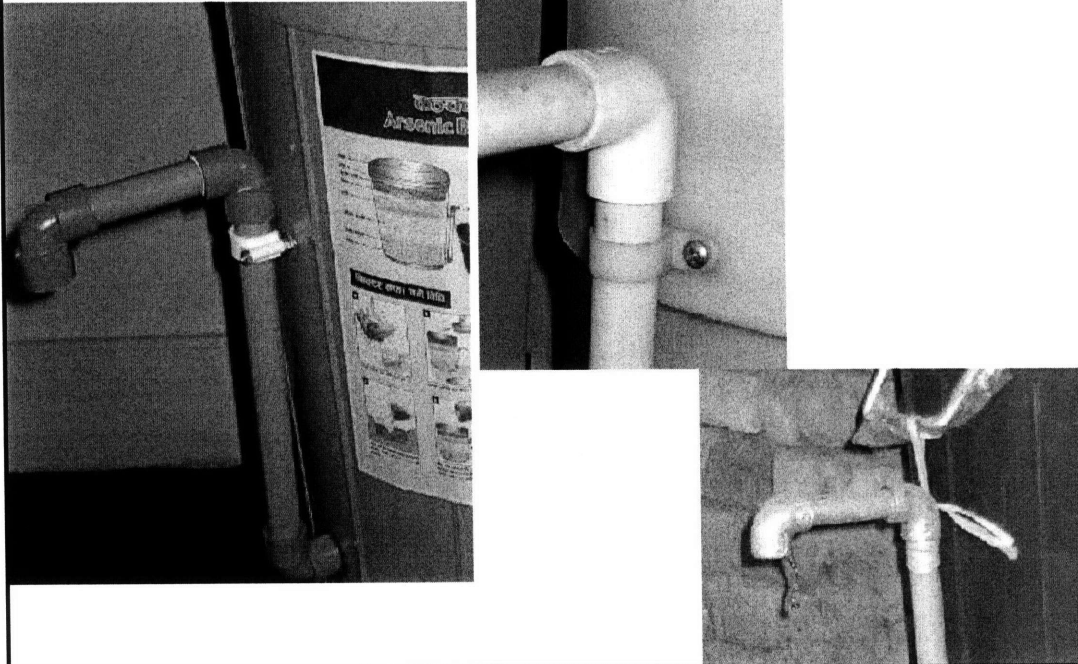

Major Filter Components

Specifications:

Fine Sand
→ 20 to 22 Liters
→ less than 1mm diameter

Coarse Sand
→ 4 Liters
→ 3 to 6 mm diameter

Gravel
→ 6 Liters
→ 6 to 15 mm diameter

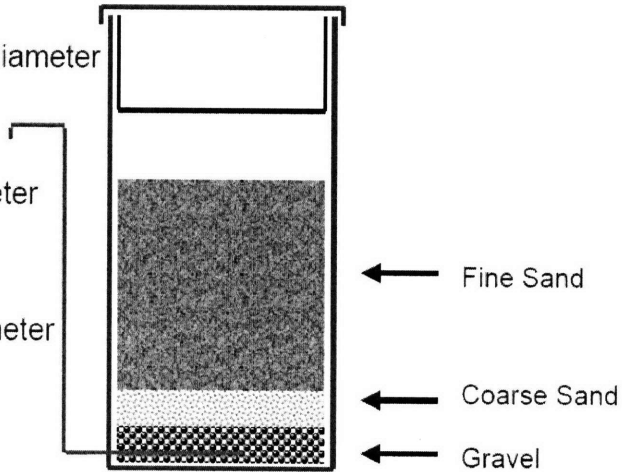

Major Filter Components

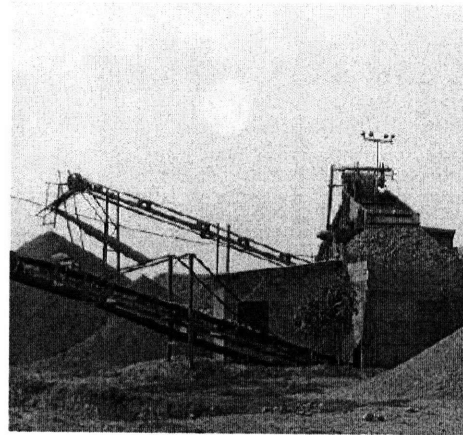

Sand and Gravel can be obtained from nearby rivers or crushers

Major Filter Components



Ideal gravel
– correct size, uniform size,
clean with no silt, dirt, small
particles or other visual
contaminations



Poor gravel
– too big size, mixed up large
and small sizes

Major Filter Components

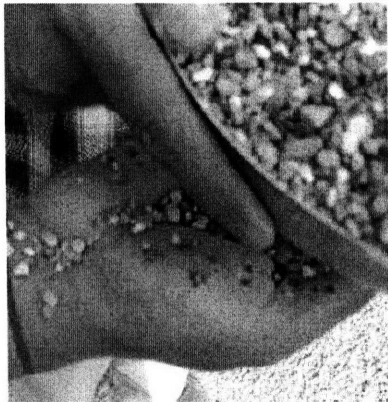

Ideal coarse sand
- correct size, clean with no
silt, dirt, small particles or
other visual contaminations



Poor coarse sand
– non uniform size, mixed up
with lots of dirt, silt, and fine
sand

Major Filter Components



Ideal fine sand
- correct size, no large particles
or visual contamination



Poor fine sand
- non uniform size, mixed up
with lots of dirt, silt, and large
particles

Major Filter Components

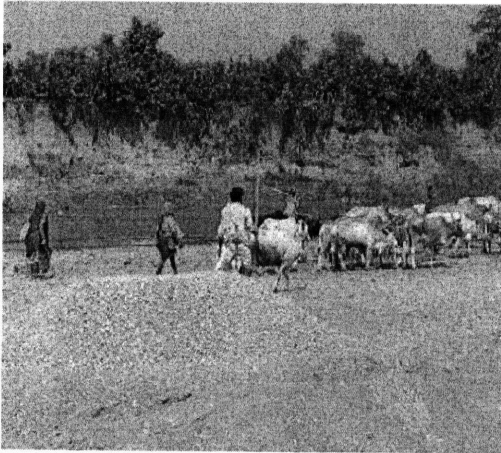

Avoid sand/gravel sources
with animal contamination

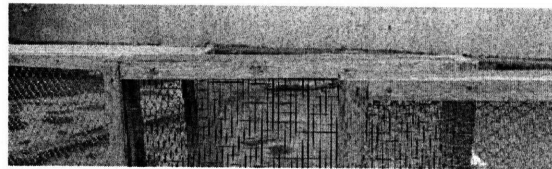

Use gauge 2 screen for gravel,
gauge 5 for coarse sand,
gauge 14 for fine sand

Major Filter Components

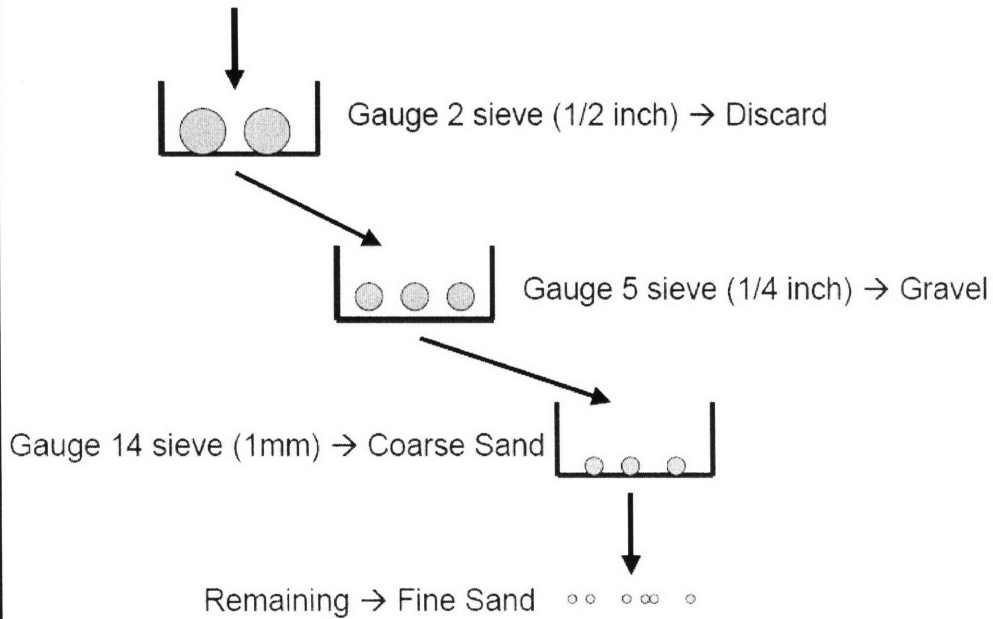

Major Filter Components

- Fine sand should be washed fairly clean.
- If sand is placed in a clear glass of water, and the sand is stirred, the suspended solids should be minimal.

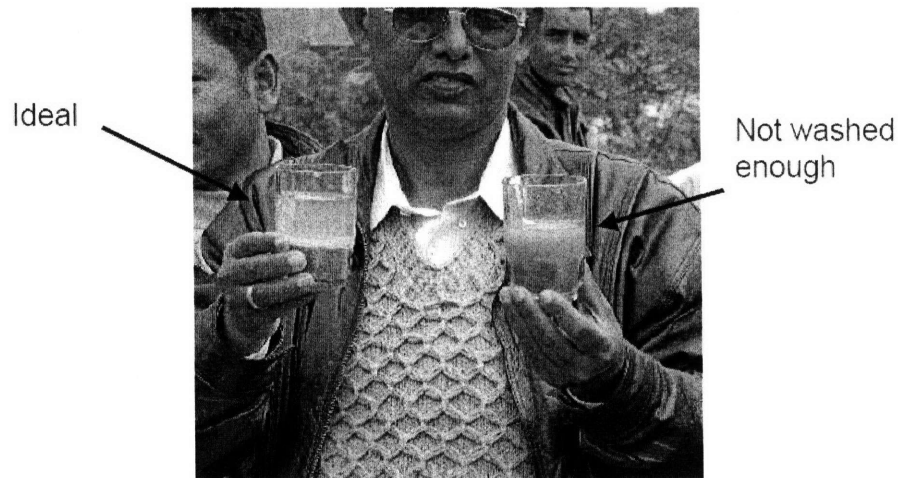

Major Filter Components

Specifications:

Iron nails

- 5 kg
- smallest size is best
- length < 20mm
- must be non-galvanized (must rust)

Brick chips

- any brick is fine
- about 5 to 10 cm diameter

Plate

- any perforated plate that can protect the iron nails

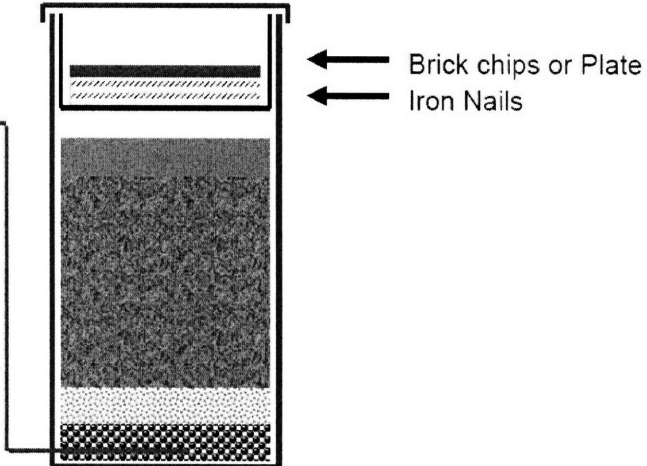

Major Filter Components

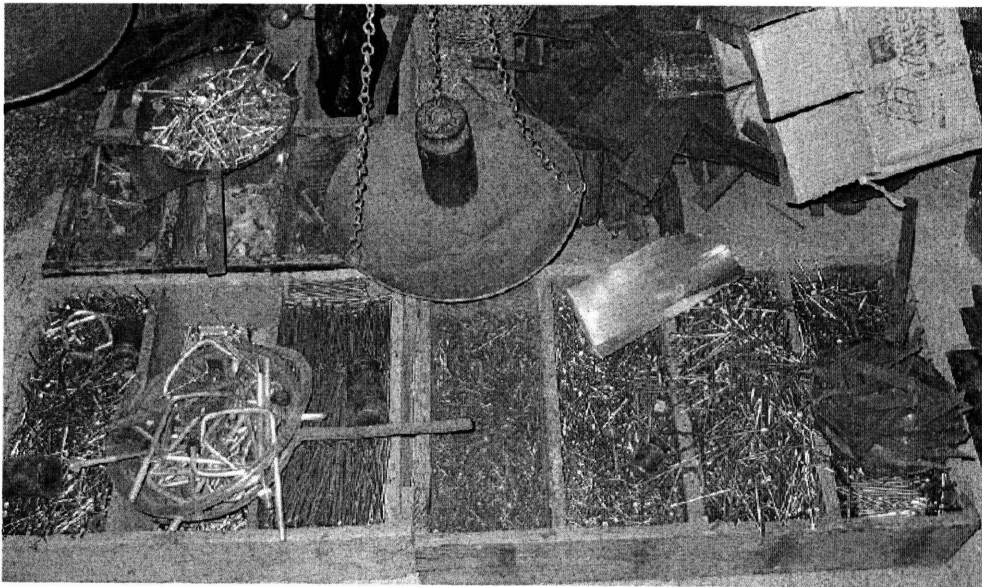

Choose the smallest, cheapest, non-galvanized iron nails from your local dealers. Buying in bulk to save money.

Filter Construction

Filter Construction

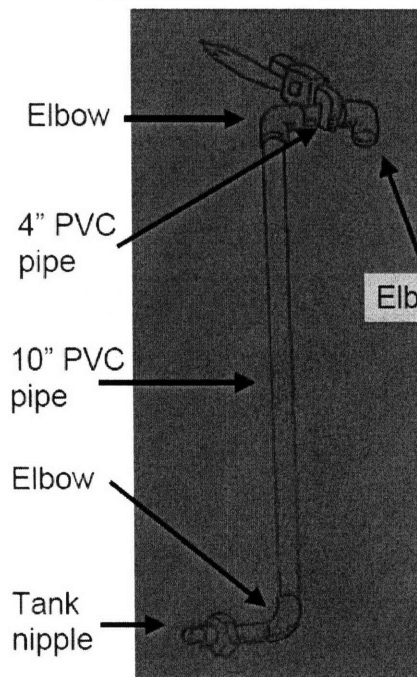

1. Measure and cut two pieces of PVC pipe (10 inches and 4 inches long)
2. Thread both ends of both PVC sections

Filter Construction



3. Attach elbows and tank nipple. Tighten the pipe fittings to the PVC pipe using a pair of wrenches (spanners)

Filter Construction



4. Pipes should be properly sealed with Teflon Tape and Glue to avoid leakage



Filter Construction

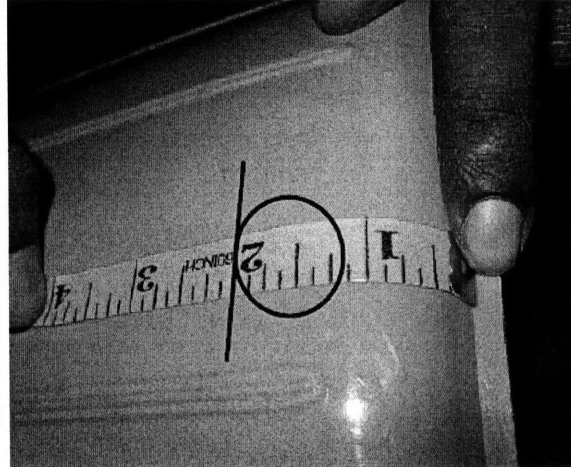
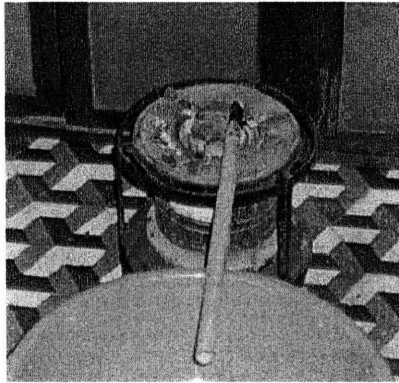

5. Make a fire to heat a $\frac{1}{2}$ inch G.I. Pipe
6. Draw a line at 2 inches from the bottom of the Gem505.
Puncture one hole below the line using the hot pipe

Filter Construction

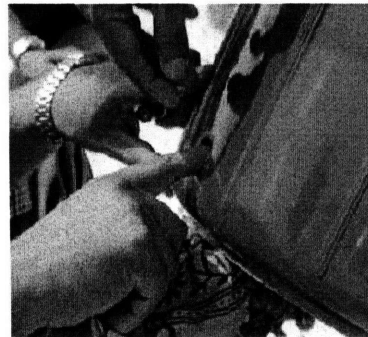

Filter Construction

7. Measure and cut a PVC pipe 8 inches long
8. Seal one end of the PVC pipe with a cap
9. Connect the PVC pipe to a socket



10. Drill two holes on PVC pipe (at location 2 inches from the sealed end, and at 2 inches from open end), using a hot bicycle spike/rod.

Filter Construction

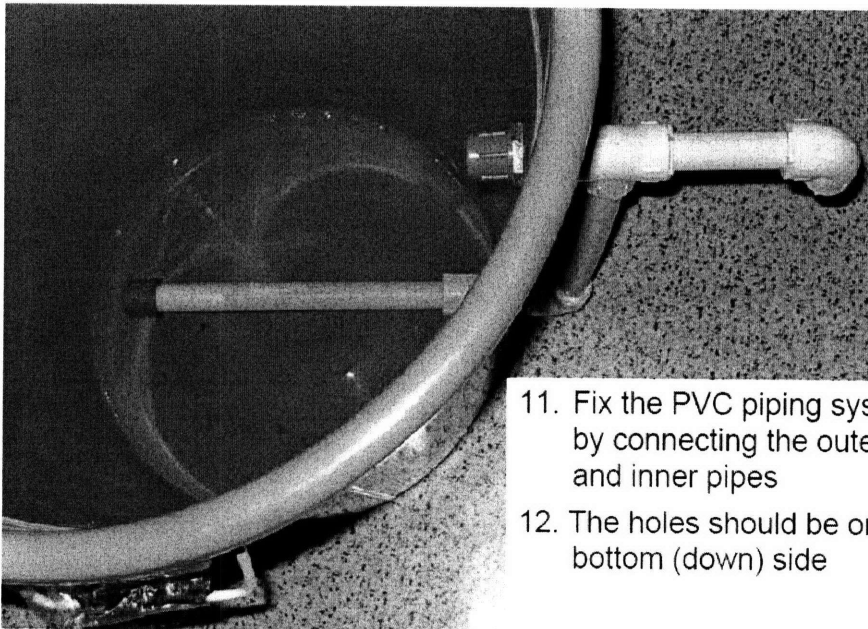

11. Fix the PVC piping system by connecting the outer and inner pipes
12. The holes should be on the bottom (down) side

Filter Construction

Tank
nipple

Socket

Drainage
pipe

Sealed end

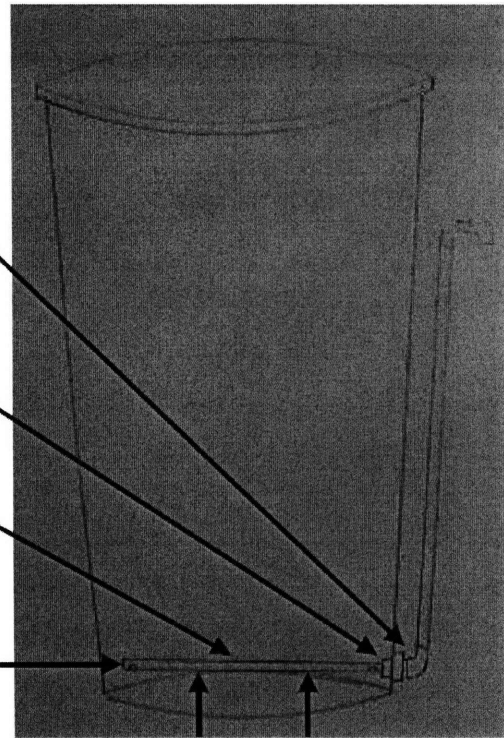

Two holes, 2 mm diameter

Filter Construction



13. Heat bicycle wheel rod.
14. Puncture holes on the bottom side of basin

40 evenly distributed holes →

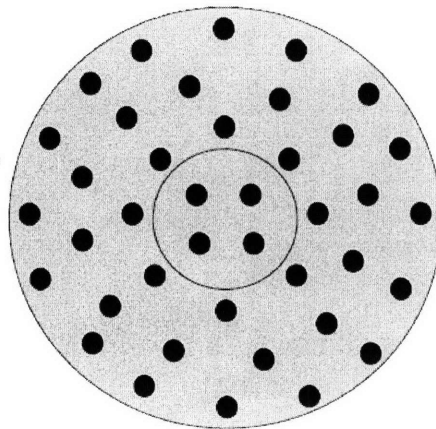

Filter Construction

15. Fill up the container to full with water
16. Visually check for leakage from the outside
17. Check time needed to fill a 1L jug (Gem016). Time should be between 2 to 3 minutes.

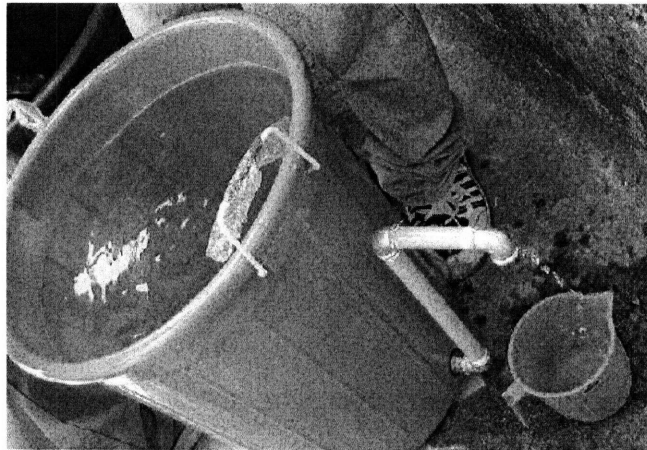

Filter Construction

18. If time is less than 2 minutes (i.e. flow rate too fast), then
19. Use your fingers to close the two holes in the drainage pipe. There should be no flow
20. If there is no flow → the hole is too big. Need to make a new drainage pipe
21. If there is flow → check for leakage



Filter Construction

22. Check for leakage at the socket/ tank nipple connection
23. Tighten if necessary
24. Otherwise the filter construction is finished



Filter Installation

Filter Installation

1. Use bricks to prepare a flat surface. The surface must be very flat or the filter may become unstable and be broken

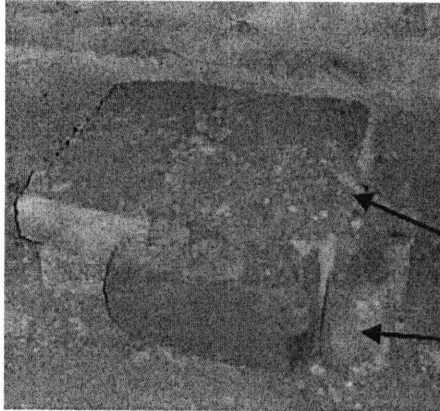

2. Put a thick layer (at least 3 cm) of mud and sand on the brick surface. This mud/sand layer should be flat.

Mud and sand layer

Brick layer

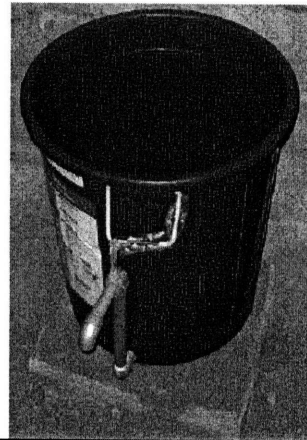

3. Place the filter securely on the layer of mud and sand.

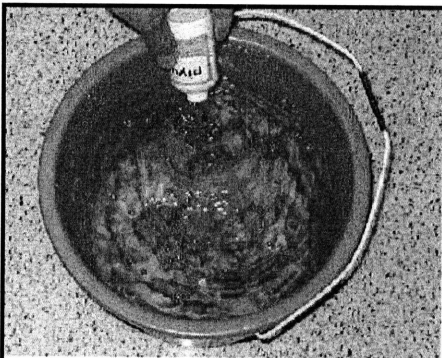

Filter Installation

4. Add two bottles of Piyush in 10 Liters of water.

5. Pour Piyush water into filter

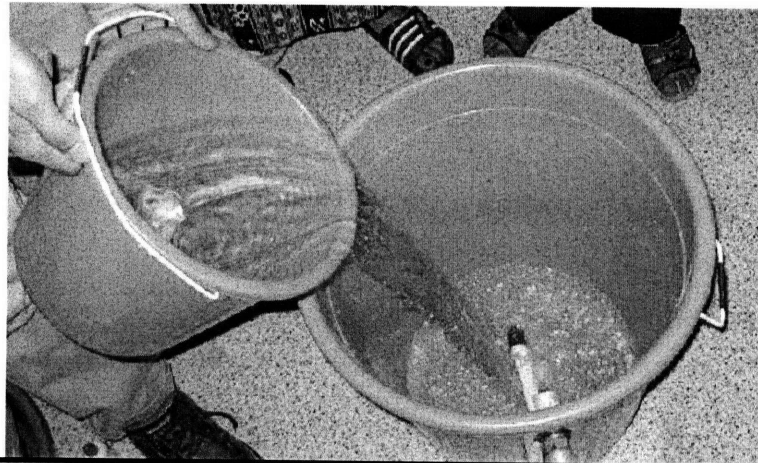



6. Using a Gem016 jug (1 L capacity), measure 6 L of previously washed gravel.

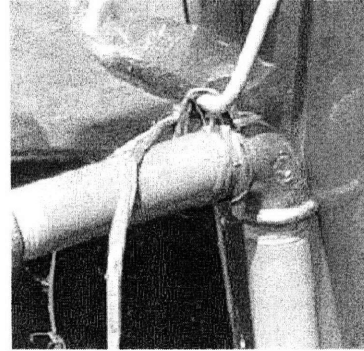

7. Slowly add gravel to the filter. Flatten the gravel surface with your hand. The gravel should cover the entire drainage pipe. If not, then the drainage pipe was incorrectly setup. Either the hole in the Gem505 is at the wrong location, or the tank nipple was not tight enough. Secure the outer PVC pipe may also help to level (lower) the drainage pipe inside.

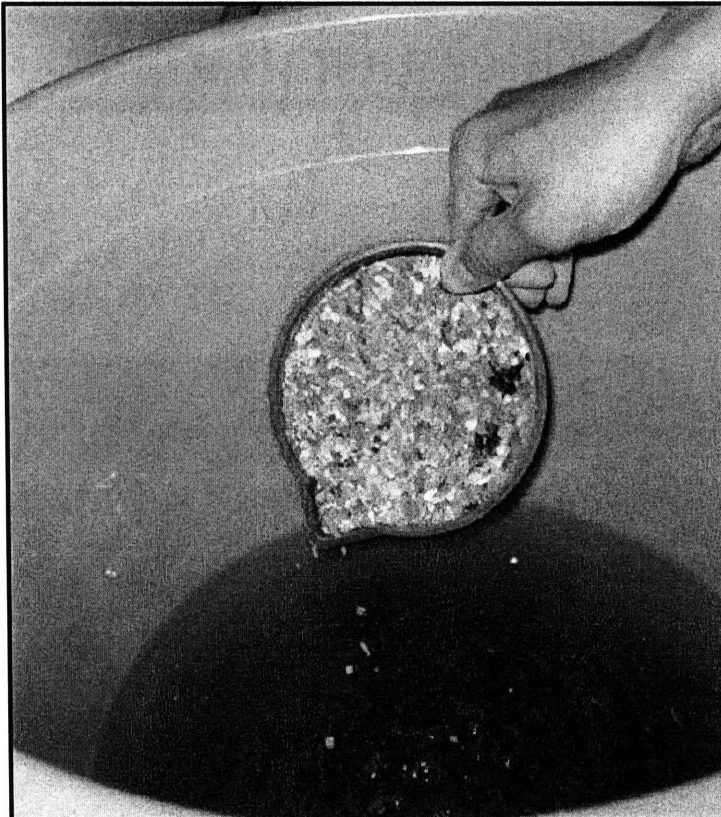

8. Using a Gem016 jug, measure 4 L of previously washed coarse sand.

9. Slowly add coarse sand to the filter. Make sure the interface is flat, and do not mix the gravel and sand

10. Using the Gem016 again, slowly add 5 L of water (non-Piyush) to the container. Do not disturb the sand and/or gravel layers.

Filter Installation



12. Slowly add fine sand to the filter. Make sure not to disturb/ mix the different media layers. Add until there is 5 cm of standing water.

11. Measure about 20-22 L of previously washed fine sand.



Filter Installation



13. The water may appear little dirty with minimal foam. (as shown in left) This is fine. However, if there is too much foam (as shown below), then the fine sand has not been cleaned enough. The fine sand must be cleaned again, and the filter must be re-installed again.

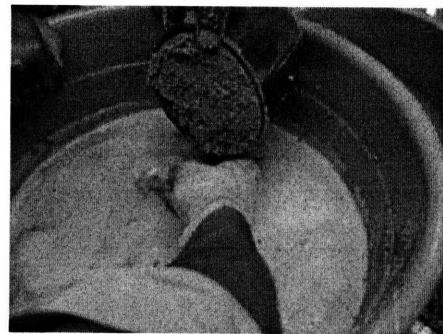

Filter Installation



13. Put iron nails in the diffuser basin. Lay the nails flatly. Then add brick chips to cover the entire basin.



If iron nails is not protected, then arsenic removal efficiency will decrease as water passes through the basin without contact with iron nails.



Filter Installation



14. Cover with lid.
15. Wait for 48 hours for Piyush to disinfect the sand and gravel.
16. After 48 hours, perform filter maintenance, that is, to clean the top layer of sand according to maintenance procedure.

Filter Installation



17. Clean the top layer of sand until you get clear water

Filter Installation

18. Pour 50 L of water in the filter and discard the filtered water.
19. Now the filter is ready to be used



Trouble Shooting

Trouble-Shooting

Problem No.1 - Too low flow rate (less than 5 Liters per hour)

1. Filter maintenance. Clean the top layer of sand. If doesn't work, then
2. Check clogging in the diffuser basin. Take the basin out and pour water into the basin. If basin clogs, then remove and wash iron nails and brick chip to clean out the dirt. Also wash the basin and clear out any holes that has been blocked by iron sludge/ dirt. If doesn't work, then
3. Remove all sand and gravel. Check for blockage in the pipe. Sieve sand and gravel. Re-install gravel and sand. Keep in mind that that there should be always water in the filter before adding gravel and/or sand to avoid trapped air bubbles. If doesn't work, then
4. Contact ENPHO. This is interesting. We also want to know why.



Top sand layer will clog. It is normal. It is because of the accumulation of dirt, dust, iron particles, and/or other contaminant particles.

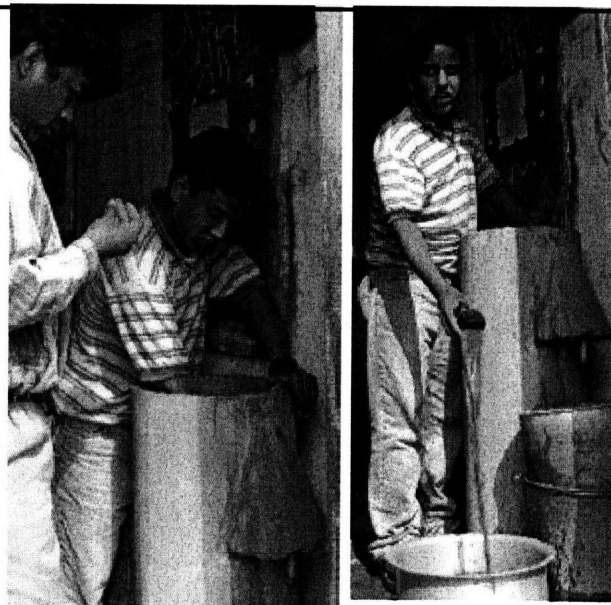

Filter maintenance (i.e. cleaning the top layer of sand) can often return the flow rate to normal

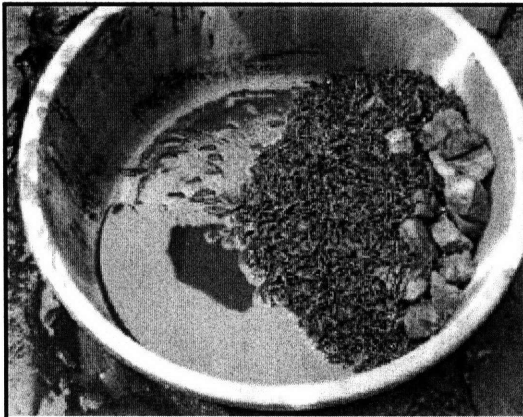

Iron nails and/or brick chips can be very dirty. They must be washed to remove dirt and sand particles before placing into the diffuser basin

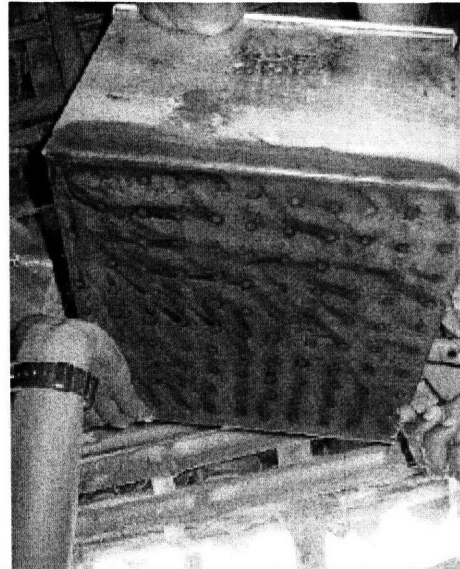

Remove the diffuser basin to check for clogging in the basin



Iron nails and/or brick chips were not washed prior to installation. Dirt from nails and/or brick clogs the holes in the diffuser basin.



Holes too small will get clogged easily.
Holes too large will allow iron nails to pass.
Proper size is necessary.

Trouble-Shooting

Problem No.2 – Gem505 container breakage

1. The filter should be placed on a flat, stable surface.
2. The filter should be placed indoors, away from the sun. Sun's UV ray may damage the plastic, making it fragile.
3. Be careful when making the hold in the Gem505 filter. Small crack near the hole may become a big crack, and eventually damage the container.

Trouble-Shooting

Problem No.3 – Leakage

1. If the leakage in on the outside pipe system, re-seal with Telfon tape and/or glue. If not, then
2. Check leakage at the bottom of the Gem505 container. There may be a crack. Seal with glue. Put the filter on a very flat surface with a 3cm layer of mud and sand. If not, then
3. Remove all sand and gravel. Check for seal for the entire piping system. Re-seal if necessary. The tank nipple rings may be jammed. Replace entire pipe or fitting parts if necessary. If doesn't work, then
4. Replacement of the plastic Gem505 container may be needed. If doesn't work, then
5. Contact ENPHO. This is interesting. We also want to know why.

Trouble-Shooting

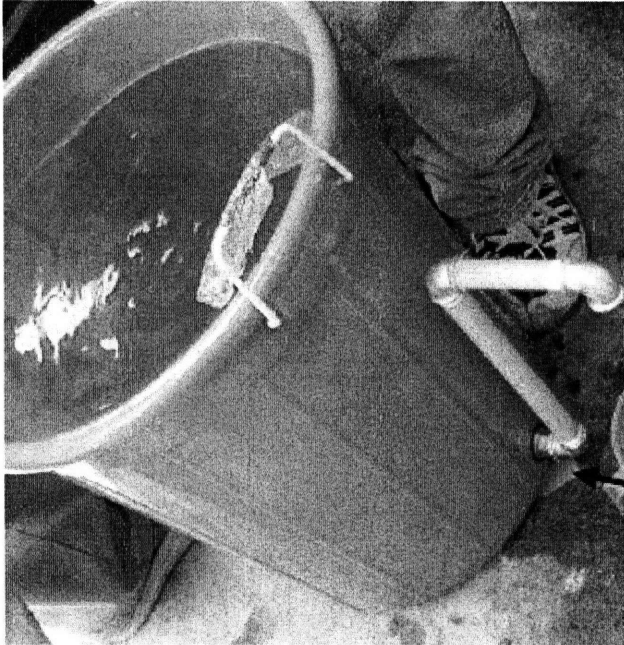

Leakage is commonly found here. Possible reasons may include: Inadequate tightening of the tank nipple, tank nipple ring jammed, insufficient Telfon tape.

Trouble-Shooting



Due to the pressure of the sand and water, the bottom of the Gem505 container may crack. To prevent this problem, the filter must be placed on a very flat surface with a 3cm thick layer of sand and mud. This will help support the pressure of the sand and water.

Appendix D Correlation Analysis of Turbidity Values Measured in Nephelometric Turbidity Units (NTU) and Turbidity Units (TU)

(Source: Adapted from Losleben, 2008)

Based on a t -test conducted on turbidity values obtained in laboratory and field testing, Losleben has reported that “it is likely that there is significant difference between the outcomes of the Nephelometric Turbidity Units (NTU) and Turbidity Units (TU)” measurements. As shown in the figure below, the results obtained in laboratory studies show a relatively good linear relation ($R^2 = 0.923$). The relation between turbidity values measured in NTU (x) and TU (y) is,

$$y = 0.740 x$$

In this thesis, this equation was used to convert turbidity values measured in TU to NTU.

