

MASSACHUSETTS INSTITUTE OF TECHNOLOGY

RESEARCH LABORATORY OF ELECTRONICS

Technical Report 432

March 31, 1965

SUPERPOSITION IN A CLASS OF NONLINEAR SYSTEMS

Alan V. Oppenheim

Submitted to the Department of Electrical Engineering, M. I. T.,
May 15, 1964, in partial fulfillment of the requirements for the
degree of Doctor of Sciences.

(Manuscript received November 27, 1964)

MASSACHUSETTS INSTITUTE OF TECHNOLOGY

RESEARCH LABORATORY OF ELECTRONICS

Technical Report 432

March 31, 1965

SUPERPOSITION IN A CLASS OF NONLINEAR SYSTEMS

Alan V. Oppenheim

Submitted to the Department of Electrical Engineering, M. I. T.,
May 15, 1964, in partial fulfillment of the requirements for the
degree of Doctor of Sciences.

(Manuscript received November 27, 1964)

Abstract

Many nonlinear systems can be interpreted as linear transformations between vector spaces under appropriate definitions for the vector operations on the inputs and outputs. The class of systems which can be represented in this way, is discussed here. This class, referred to as the class of homomorphic systems, is shown to include all invertible systems. Necessary and sufficient conditions on a noninvertible system such that it is a homomorphic system, are derived.

A canonic representation of homomorphic systems is presented. This representation consists of a cascade of three systems, the first and last of which are determined only by the vector space of inputs and the vector space of outputs, respectively. The second system in the canonic representation is a linear system. Necessary and sufficient conditions are presented under which all of the memory in the system can be concentrated in the linear portion of the canonic representation. A means for classifying homomorphic systems, suggested by the canonic representation, is discussed. This means of classification offers the advantage that systems within a class differ only in the linear portion of the canonic representation. Applications of the theory are considered for a class of nonlinear feedback systems.



TABLE OF CONTENTS

I.	INTRODUCTION	1
II.	VECTOR SPACES AND LINEAR TRANSFORMATIONS	3
	2.1 Introduction	3
	2.2 Groups, Fields, and Vector Spaces	3
	2.3 Quotient Spaces	8
	2.4 Linear Transformations	10
	2.5 Infinite-Dimensional Vector Spaces	15
III.	GENERALIZED SUPERPOSITION AND HOMOMORPHIC SYSTEMS	25
	3.1 Introduction	25
	3.2 Generalized Principle of Superposition	25
	3.3 Invertible Homomorphic Systems	27
	3.4 Noninvertible Homomorphic Systems	31
IV.	CANONIC REPRESENTATION FOR HOMOMORPHIC SYSTEMS	40
	4.1 Introduction	40
	4.2 Canonic Representation	41
	4.3 Classifying Homomorphic Systems	43
	4.4 Conditions on a Homomorphic System Such That the Characteristic Systems are Memoryless	43
	4.5 Application to Nonadditive Feedback Systems	54
APPENDIX	Isomorphic Mapping of a Separable Hilbert Space into the Space F^n	59
	Acknowledgment	61
	References	62

I. INTRODUCTION

The analysis and characterization of linear systems rely heavily on the principle of superposition which these systems satisfy. The superposition integral and system function representations, for example, are a direct consequence of the fact that the response of a linear system to each input in a set of inputs determines the response to any linear combination of inputs in that set.

In contrast, nonlinear systems do not satisfy this principle of superposition. The determination of a means for representing nonlinear systems has been the subject of considerable attention for many years. In 1887, Volterra¹ formulated a functional expansion of continuous nonlinear operators in the form of a generalization of the Taylor's series expansion of a nonlinear function. This expansion, applied to systems, provides a representation of the system operator. A representation of time-invariant, realizable nonlinear systems was presented by Wiener,² in 1958. In his theory, system response to shot noise is used to determine the parameters of the representation. Wiener's formulation is based on the expansion of the past of an input in terms of Laguerre functions, which was first presented by Cameron and Martin.³ The response of a realizable time-invariant nonlinear system is expressed as a nonlinear combination of the coefficients in this expansion. Cameron and Martin represented the nonlinear combination of these coefficients in terms of Hermite functions. An alternative representation of the nonlinear combination of the coefficients was developed by Bose,⁴ in 1956. Much of the research being conducted, at present, on the representation of nonlinear systems is based on Wiener's original ideas.

This report presents a different approach to the characterization of nonlinear systems, which is based on linear algebra. The fact that vector spaces of time functions can be constructed under a variety of choices for the definitions of vector addition and scalar multiplication permits many nonlinear systems to be representable as linear transformations between vector spaces. Specifically, if $f_1(t)$ and $f_2(t)$ represent any two system inputs, let $f_1(t) \circ f_2(t)$ denote the combination of these inputs under a specified rule, such as addition, multiplication or convolution. If c is any scalar, let $c > f_1(t)$ denote the combination of the scalar c and the input $f_1(t)$. Similarly, let \square denote a rule of combination between any two outputs, and $/$ denote a rule of combination between any scalar and any output. If the system inputs constitute a vector space when \circ is interpreted as vector addition and $>$ is interpreted as scalar multiplication, and if the system operator ϕ has the property that

$$\phi[f_1(t) \circ f_2(t)] = \phi[f_1(t)] \square \phi[f_2(t)]$$

and

$$\phi[c > f_1(t)] = c / \phi[f_1(t)],$$

then it is representable as a linear transformation between vector spaces. In the case

for which the operations $+$ and \square are addition and the operations $>$ and $/$ are multiplication, the system is a linear system. Otherwise, the system is in general nonlinear. Systems representable in this way are referred to here as homomorphic systems, a term motivated by the algebraic definition of a homomorphic mapping between vector spaces.

The algebraic fundamentals for the study of homomorphic systems are presented in Section II. This presentation sets down the basic postulates of linear algebra and develops the algebraic theorems that are needed in the study of homomorphic systems.

In Sections III and IV the properties of linear transformations are used to investigate homomorphic systems. It is shown in Section III that every invertible system is homomorphic for any choice of the input vector space. For noninvertible systems, necessary and sufficient conditions are derived under which the systems are homomorphic.

In Section IV a canonic representation for homomorphic systems is developed. This representation consists of a cascade of three systems, the first and last of which are determined entirely by the input and output vector spaces, respectively. The second system in the representation is a linear system. Necessary and sufficient conditions are derived in Section IV under which the first and last systems in the canonic representation are memoryless. Section IV also includes a discussion of the use of the canonic representation in treating a class of nonadditive feedback systems.

The canonic representation presented here offers a convenient means for classifying homomorphic systems. Systems within a given class differ only in the linear portion of their canonic representation and hence a comparison of systems within a class reduces to a comparison of linear systems. Alternatively, the analysis of a homomorphic system, when its class is known, reduces to the analysis of a linear system.

II. VECTOR SPACES AND LINEAR TRANSFORMATIONS

2.1 INTRODUCTION

The results presented in this report draw heavily on the notation, concepts, and theorems of linear algebra. Hence it is appropriate to introduce the fundamental properties of vector spaces and linear transformations, and to remind the reader who is familiar with vector spaces of the properties used here. Although proofs of all theorems have been included, it is the theorems themselves that will assume primary importance. For the reader who is familiar with linear algebra, a quick review should be adequate to convey the point of view toward linear algebra which is used in this report. Many of the theorems and proofs presented here have been published by others.⁵⁻⁷ Some of these were reformulated in terms that were more meaningful within the context of this report. The remainder of the theorems were formulated and proved specifically for the purposes of this report.

2.2 GROUPS, FIELDS, AND VECTOR SPACES

It is convenient to introduce the postulates of the algebra of vector spaces by introducing the postulates of groups, which constitute a weaker algebraic system.

DEFINITION 1: A group G is a collection of objects for which a binary operation $*$ is defined, subject to the following postulates:

1. If a and b are in G , then $a*b$ is in G .
2. If a , b , and c are in G , then

$$(a*b)*c = a*(b*c).$$

3. There exists a unique element e in G , called the identity element, such that for all a in G ,

$$a*e = e*a = a.$$

4. For every element a in G , there exists a unique element a^{-1} in G , such that

$$a*a^{-1} = a^{-1}*a = e.$$

If the group G has the property that for all elements a and b in G , $a*b = b*a$, then G is referred to as a commutative or Abelian group. Often when discussing Abelian groups, the binary operation associated with the group is denoted $+$ to emphasize the fact that the group operation is commutative. In this case, the identity element is referred to as the zero element. This notation will be used now. Little confusion results when the elements of the groups are abstract objects. When the group elements are real or complex numbers or functions, however, the reader should remember that the element $a+b$ in the group is not necessarily the addition of the numbers (or functions) a and b . The algebraic postulates can be satisfied, for example, if $a+b$ is defined as the product of the numbers or functions a and b .

DEFINITION 2: A field F is a collection of objects associated with which there are two binary operations. The first operation is denoted $a+b$. The second operation is denoted $a \cdot b$. These operations satisfy the following postulates:

1. The field F is an Abelian group under the operation $+$.
2. The nonzero elements of F are an Abelian group under the operation \cdot . The identity under this operation is denoted by 1 .

3. For any a, b , and c in F ,

$$a \cdot (b+c) = a \cdot b + a \cdot c.$$

It should again be mentioned that the operations $+$ and \cdot , although satisfying the same algebraic postulates satisfied by addition and multiplication of numbers or functions, are not necessarily restricted to be these operations when the elements of the field are chosen to be real or complex numbers or functions.

DEFINITION 3: A vector space consists of

1. A field F of scalars;
2. A set V of objects called vectors and a binary operation called vector addition (to be denoted $+$) under which the set V constitutes an Abelian group; and
3. An operation called scalar multiplication which associates with each scalar c in F and vector v in V a vector cv in V called the product of c and v in such a way that

$$(a) \quad 1v = v \text{ for every } v \text{ in } V$$

$$(b) \quad (c_1 \cdot c_2)v = c_1(c_2v)$$

$$(c) \quad c(v_1+v_2) = cv_1 + cv_2$$

$$(d) \quad (c_1+c_2)v = c_1v + c_2v.$$

The inverse of a vector v is denoted $-v$. It can easily be verified that

$$(-1)v = -v$$

and

$$(0)v = 0$$

DEFINITION 4: Let V be a vector space over the field F . A subspace of V is a subset V_1 of V which is itself a vector space over F with the operations of vector addition and scalar multiplication on V .

A simple example of a subspace of V is the space consisting of the zero vector alone. When verifying that a subset of a vector space is a subspace we need not verify all of the postulates of a vector space, since many of the postulates are implied by the fact that the set is a subset of a vector space. In general, it is sufficient to show that if v_1 and v_2 are in V_1 , then any linear combination of v_1 and v_2 is also in V_1 .

DEFINITION 5: A vector space can be extended to what is termed an inner product space by defining the inner product between any two vectors in the space. The inner product assigns to each ordered pair of vectors v_1, v_2 in V a scalar (v_1, v_2) in F in such a way that

1. $(v_1 + v_2, v_3) = (v_1, v_3) + (v_2, v_3)$.
2. $(cv_1, v_2) = c \cdot (v_1, v_2)$.
3. $(v_1, v_2) = \overline{(v_2, v_1)}$, where the bar denotes complex conjugation.
4. $(v, v) > 0$ if $v \neq 0$.

Two vectors having the property that their inner product is zero are said to be orthogonal. The length of a vector v in an inner product space is defined as the square root of (v, v) and is denoted $\|v\|$. A set of vectors that are orthogonal to each other and have unit length is termed an orthonormal set.

Vector spaces can be constructed for which the elements are functions of time, but for which the operations of vector addition and scalar multiplication do not correspond to addition of time functions and multiplication of time functions by scalars. For example, consider the set of all time functions of the form $v = e^{nt}$, where n is a real number. If we associate with this set the field of real numbers and define vector addition and scalar multiplication as

$$v_1 + v_2 = v_1(t) + v_2(t) = e^{n_1 t} + e^{n_2 t}$$

and

$$cv = [v(t)]^c = [e^{nt}]^c,$$

then this set constitutes a vector space.

Many of the important and useful theorems concerning vector spaces and linear transformations between vector spaces stem from the fact that a set of basis vectors can always be found for a finite-dimensional vector space. The notion of a basis is presented in the following definitions and theorems.

DEFINITION 6: Let V be a vector space over F . A finite subset S of V is said to be linearly dependent if there exist scalars c_1, c_2, \dots, c_n in F , not all of which are 0, and distinct vectors v_1, v_2, \dots, v_n in S such that

$$c_1 v_1 + c_2 v_2 + \dots + c_n v_n = 0.$$

A set that is not linearly dependent is called linearly independent. If a set of vectors is infinite, then it is said to be a linearly independent set if every finite subset of it is linearly independent. A set of vectors in V which is linearly independent and spans V , that is, is such that any vector in V can be expressed as a finite linear combination of the vectors in the set, is referred to as a basis for V ;

It can be verified that any set containing the zero vector is a linearly dependent set, and that the representation for any vector in terms of a basis is unique.

THEOREM 1: Let V be a vector space for which the finite set of vectors v_1, v_2, \dots, v_n forms a basis. Then any other basis for V contains exactly n vectors.

PROOF: First, we shall show that any set of vectors containing more than n elements must be linearly dependent. To this end, let w_1, w_2, \dots, w_m be a set of m vectors from V with $m > n$. Since the set v_1, v_2, \dots, v_n is a basis, each of the vectors w_i is expressible as a linear combination of the vectors v_1, v_2, \dots, v_n ; that is,

$$w_i = \sum_{j=1}^n c_{ji} v_j.$$

Let $\lambda_1, \lambda_2, \dots, \lambda_m$ be scalars from F . Then

$$\sum_{i=1}^m \lambda_i w_i = \sum_{i=1}^m \lambda_i \sum_{j=1}^n c_{ji} v_j = \sum_{j=1}^n \left(\sum_{i=1}^m c_{ji} \lambda_i \right) v_j.$$

Since $m > n$, the set of equations

$$\sum_{i=1}^m c_{ji} \lambda_i = 0, \quad j = 1, 2, \dots, n$$

has a nontrivial solution for the unknowns $\lambda_1, \lambda_2, \dots, \lambda_m$. Thus a set of scalars can be found, not all of which are zero, with the property that

$$\sum_{i=1}^m \lambda_i w_i = 0.$$

Hence the set w_1, w_2, \dots, w_m cannot be a linearly independent set; therefore, no linearly independent set in V , in particular, no basis for V can contain more than n vectors. Now assume that there exists a basis with p vectors, where $p < n$. Then, by virtue of the discussion above, there could not exist a basis with more than p vectors. But the set of basis vectors v_1, v_2, \dots, v_n has more than p vectors. Thus there could not have existed a basis with p vectors, where $p < n$.

By virtue of Theorem 1, we see that any basis for a vector space with a finite number of basis vectors contains the same number of vectors. It is this property of vector spaces that permits the definition of the dimension of a vector space independently of any particular basis.

DEFINITION 7: The dimension of V is defined to be the number of elements in a basis of V . The dimension of a vector space V will be denoted $\dim V$.

Many of the theorems of linear algebra center around finite-dimensional vector spaces. Infinite-dimensional vector spaces present special problems and many theorems concerning these spaces require special restrictions on the spaces. Infinite-dimensional vector spaces will be considered. Before doing so, it is important that the properties of finite-dimensional vector spaces be understood so that the extensions of these properties to infinite-dimensional spaces will be clearer.

THEOREM 2: Let S be a linearly independent subset of a finite-dimensional vector space V . Then S is part of a basis for V .

PROOF: Let W be the subspace of V spanned by S . Then, by definition, S is a basis for W . If $W = V$, then S is also a basis for V and the proof is complete. If W is a proper subspace of V (that is, contained in but not equal to V), let v_1 be a vector that is in V but not in W . The set $\{v_1, S\}$ obtained by adjoining v_1 to S is linearly independent, for if v_1 could be expressed as a linear combination of vectors in S , then v_1 would be in W .

Let V_1 be the subspace of V spanned by $\{v_1, S\}$. If $V_1 = V$, then $\{v_1, S\}$ is a basis for V , since it is a basis for V_1 . If V_1 is a proper subspace of V , let v_2 be a vector that is in V but is not in V_1 . Then the set $\{v_2, v_1, S\}$ must be linearly independent. Let this process be continued until the set $\{v_n, v_{n-1}, \dots, v_2, v_1, S\}$ contains exactly $\dim V$ elements. Since these vectors are all linearly independent, the space V_n spanned by this set must be all of V ; otherwise, a vector v_{n+1} that is in V but not in V_n could be adjoined to this set, forming a linearly independent set with more than $\dim V$ elements. In the proof of Theorem 1, however, it was shown that no linearly independent set of V could contain more than $\dim V$ elements.

By the procedure above, then, the set S was extended to a basis of V and hence is itself part of a basis.

It follows from Theorem 2 that if V_1 is a proper subspace of a finite-dimensional vector space V , then $\dim V_1 < \dim V$. This follows from the fact that any basis for V_1 is part of a basis for V . Since V_1 is a proper subspace of V , however, a set of vectors must be adjoined to the set of basis vectors for V_1 to form a basis for V , these vectors being chosen by the procedure given in the proof of Theorem 2.

The existence of a basis leads to a representation of a vector as an n -tuple of scalars. This representation comes about by expressing every vector in terms of an ordered basis for the space V . A one-to-one correspondence can then be drawn between any vector in V and the n -tuple of the coordinates expressing this vector in terms of the ordered basis. This is done formally by first defining a vector space, the elements of which are n -tuples having entries from the field F .

DEFINITION 8: The vector space F^n is defined to be the vector space having elements of the form (a_1, a_2, \dots, a_n) , where a_1, a_2, \dots, a_n are scalars from the field F . The vector addition of two vectors (a_1, a_2, \dots, a_n) and (b_1, b_2, \dots, b_n) in F^n is defined as

$$(a_1, a_2, \dots, a_n) + (b_1, b_2, \dots, b_n) = (a_1 + b_1, a_2 + b_2, \dots, a_n + b_n).$$

The scalar multiplication of a vector (a_1, a_2, \dots, a_n) in F^n with a scalar c in F is defined as

$$c(a_1, a_2, \dots, a_n) = (ca_1, ca_2, \dots, ca_n).$$

Let V be a finite dimensional vector space over F with

$$\dim V = n.$$

If v_1, v_2, \dots, v_n is an ordered basis for V , then any vector v can be expressed in the form

$$v = a_1 v_1 + a_2 v_2 + \dots + a_n v_n.$$

If we draw a correspondence between v and the n -tuple (a_1, a_2, \dots, a_n) in F^n , then this correspondence will be one-to-one, since any vector v in V can be expressed in one and only one way in terms of a given ordered basis.

2.3 QUOTIENT SPACES

A concept that will have application in the discussion of linear transformations, and also in the discussion of homomorphic systems, is that of a quotient space. The essence of the idea is to divide a vector space V into sets of vectors, S_1, S_2, \dots, S_n with the property that the sets S_1, S_2, \dots, S_n can themselves be considered as vectors in a vector space.

DEFINITION 9: Let V_1 be a subspace of V , and v_1 be a vector in V . Let S_1 be the set of all vectors in V which can be expressed in the form $v_1 + w$ for some w in V_1 . Denote this set by $v_1 + V_1$. This set is called a coset of V generated by v_1 and V_1 . The set of all cosets generated by vectors v in V , and the subspace V_1 is called a quotient space of V , modulo V_1 , and is denoted by V/V_1 .

THEOREM 3: Let V be a vector space over F , and V_1 be a subspace of V . The quotient space V/V_1 is a vector space over F with the following definitions of vector addition and scalar multiplication:

$$(v_1 + V_1) + (v_2 + V_1) = [v_1 + v_2] + V_1$$

$$c(v_1 + V_1) = [cv_1] + V_1.$$

PROOF: To show that V/V_1 is a vector space we must verify that all the postulates of a vector space as presented in Definition 3 are satisfied.

1. The set V/V_1 is an Abelian group, since

(a) If $v_1 + V_1$ and $v_2 + V_1$ are any two cosets of V , then their vector sum $(v_1 + v_2) + V_1$ is also a coset of V , and

$$\begin{aligned} (v_1 + V_1) + (v_2 + V_1) &= (v_1 + v_2) + V_1 \\ &= (v_2 + v_1) + V_1 \\ &= (v_2 + V_1) + (v_1 + V_1). \end{aligned}$$

(b) Let $v_1 + V_1, v_2 + V_1,$ and $v_3 + V_1$ be cosets of V ; then

$$\begin{aligned}
[(v_1+V_1)+(v_2+V_1)] + (v_3+V_1) &= [(v_1+v_2)+V_1] + (v_3+V_1) \\
&= [(v_1+v_2)+v_3] + V_1 \\
&= [v_1+(v_2+v_3)] + V_1 \\
&= (v_1+V_1) + [(v_2+V_1)+(v_3+V_1)].
\end{aligned}$$

(c) It can be verified that the coset $(0+V_1)$ has the properties required for an identity element in V/V_1 .

(d) Let $v + V_1$ be a coset of V ; then $(-v) + V_1$ is the inverse of $v + V_1$.

2. The four properties required of scalar multiplication are satisfied.

(a) $1(v+V_1) = 1v + V_1 = v + V_1$.

(b) $(c_1 \cdot c_2)(v+V_1) = c_1 \cdot c_2 v + V_1 = c_1 [c_2(v+V_1)]$.

(c) $c[(v_1+V_1)+(v_2+V_1)] = c[(v_1+v_2)+V_1]$
 $= [(cv_1+cv_2)+V_1]$
 $= (cv_1+V_1) + (cv_2+V_1)$.

(d) $(c_1+c_2)(v+V_1) = [(c_1+c_2)v+V_1]$
 $= [c_1v+c_2v+V_1]$
 $= (c_1v+V_1) + (c_2v+V_1)$.

To aid in understanding the concept of a quotient space, consider a geometrical two-dimensional coordinate system in the x - y plane. All vectors in this plane form a vector space, which we can denote by V . Let V_1 be the subspace of V consisting of all vectors lying in the x direction. Let v be a vector in V having a component in the y direction equal to v_y . Then the coset $v + V_1$ is the set of all vectors in the plane having v_y as their y component. The quotient space V/V_1 is the set of all such cosets for different values of v_y .

THEOREM 4: Let $v_a + V_1$ and $v_b + V_1$ be any two cosets in V/V_1 . If these cosets have any element in common, then they are identical.

PROOF: Let v be any vector that is in $v_a + V_1$ and also in $v_b + V_1$. Then there exists v_1 in V_1 such that

$$v = v_a + v_1,$$

and there exists v_1' in V_1 such that

$$v = v_b + v_1'.$$

Hence,

$$v_a = v_b + (v_1' - v_1).$$

Consequently,

$$v_a + V_1 = (v_b + v_1' - v_1) + V_1.$$

But $v_1' - v_1$ is in V_1 ; hence,

$$v_a + V_1 = v_b + V_1.$$

2.4 LINEAR TRANSFORMATIONS

The properties of the class of nonlinear systems to be discussed in Sections III and IV are based on the properties of linear transformations between vector spaces. The theorems to be derived concerning these systems will be for the most part an interpretation of theorems presented here, placed in the context of the discussion of Sections III and IV.

DEFINITION 10: Let V and W be vector spaces over the field F . A linear transformation from V into W is a function T from V into W which maps every vector in V onto a unique vector in W in such a way that

$$T(cv_1 + v_2) = cT(v_1) + T(v_2)$$

for all vectors v_1 and v_2 in V and all scalars c in F . A linear transformation is said to be one-to-one and onto if for each vector w in W there is one and only one vector v in V such that

$$T(v) = w.$$

A linear transformation that is one-to-one and onto is invertible.

If a transformation is onto but is not necessarily one-to-one, it is sometimes referred to as a homomorphic transformation. A transformation that is one-to-one and onto is sometimes referred to as an isomorphic transformation, that is, an isomorphic transformation is an invertible homomorphic transformation.

DEFINITION 11: The domain of a linear transformation is the set of vectors V over which the transformation T is defined. The range R of T is defined as the set of vectors in W onto which vectors in V are mapped, that is, $T[V] = R$. The null space N of T is the set of vectors in V that map onto the zero vector in W , that is, $T[N] = 0$.

An example of a linear transformation is the identity mapping I of V onto V so that

$$I(v) = v, \quad \text{for every } v \text{ in } V.$$

The domain and range of I are V . The null space of I is the zero vector. Another simple example of a linear transformation is the zero transformation Z from V to W defined as $Z(v) = 0$; all v in V . The domain and null space are both the space V . The

range of Z is the set containing only the zero vector in W .

THEOREM 5: If T is a linear transformation from V to W , then $T(0) = 0$.

PROOF: $T(0) = T(0+0) = T(0) + T(0)$. Hence, $T(0) = 0$.

THEOREM 6: Let T be a linear transformation from the vector space V into the vector space W . Then the range of T is a subspace of W , and the null space of T is a subspace of V .

PROOF: Let R denote the range of T . If the range contains only one vector, then this vector must be the zero vector, since by Theorem 5 the zero vector must be in the range. But the zero vector alone is a subspace of W , and hence in this case R is a subspace of W . If R contains more than one vector, then we must show that, for every pair of vectors w_1 and w_2 in R , the vector $c_1w_1 + c_2w_2$ is in R for any c_1 and c_2 . But if w_1 is in R and w_2 is in R , then there are (not necessarily unique) vectors v_1 and v_2 in V such that

$$T(v_1) = w_1$$

$$T(v_2) = w_2.$$

The vector $c_1v_1 + c_2v_2$ is in the domain V for any c_1 and c_2 , since V is a vector space. Hence $T(c_1v_1 + c_2v_2)$ is in R , that is, $c_1w_1 + c_2w_2$ is in R . Consequently, R is a vector space.

To show that the null space N is a vector space, we must show either that N consists of the zero vector alone or $c_1v_1 + c_2v_2$ is in N for every c_1 and c_2 , if v_1 and v_2 are in N .

From Theorem 5, the zero vector must be in N . Hence if N contains only one vector, it must be the zero vector and consequently N is a subspace of V . If N contains more than one vector, then let v_1 and v_2 be in N , that is, $T(v_1) = 0$ and $T(v_2) = 0$. Then

$$\begin{aligned} T(c_1v_1 + c_2v_2) &= c_1T(v_1) + c_2T(v_2) \\ &= c_10 + c_20 \\ &= 0 \end{aligned}$$

and hence $c_1v_1 + c_2v_2$ is in N for any c_1 and c_2 .

THEOREM 7: Let V be a finite-dimensional vector space over F , and $\{v_1, v_2, \dots, v_n\}$ be a basis for V . Let W be a vector space over F , and $\{w_1, w_2, \dots, w_n\}$ be any vectors in W . Then there is one and only one linear transformation from V into W such that

$$T(v_i) = w_i, \quad i = 1, 2, \dots, n.$$

PROOF: Any vector v in V can be expressed as

$$v = \sum_{j=1}^n c_j v_j,$$

where the coefficients c_j are unique. If we define $T(v) = \sum_{j=1}^n c_j w_j$, then

$$T(v_i) = w_i, \quad i = 1, 2, \dots, n.$$

It can be verified that, with this definition, T is a linear transformation. To prove uniqueness, let T_1 be any linear transformation with the property that

$$T_1(v_i) = w_i, \quad i = 1, 2, \dots, n.$$

Then

$$T_1(v) = T_1\left(\sum_{j=1}^n c_j v_j\right) = \sum_{j=1}^n c_j T_1(v_j) = \sum_{j=1}^n c_j w_j.$$

since T_1 is linear. Hence $T_1(v) = T(v)$ for all v ; consequently, the transformation T defined above, is unique.

THEOREM 8: Let V and W be vector spaces over F , and T be a linear transformation from V into W . If T is one-to-one and onto, then the inverse transformation T^{-1} is a linear transformation from W onto V .

PROOF: We must show that if $T^{-1}(w_1) = v_1$ and $T^{-1}(w_2) = v_2$, then $T^{-1}(cw_1 + w_2) = cv_1 + v_2$. The fact that $T(cv_1 + v_2) = cw_1 + w_2$ follows from the linearity of T . Furthermore, $cv_1 + v_2$ is the only vector in V that maps onto $cw_1 + w_2$, since T is one-to-one. Hence T^{-1} is linear.

DEFINITION 12: A linear transformation T is defined to be nonsingular if the null space of T consists of the zero vector alone.

THEOREM 9: Let T be a linear transformation from V into W . Then T is nonsingular if and only if T carries each linearly independent subset of V into a linearly independent subset of W .

PROOF: First, suppose T is nonsingular. Let the set $\{v_1, v_2, \dots, v_n\}$ be a linearly independent subset of V . If

$$c_1 T(v_1) + c_2 T(v_2) + \dots + c_n T(v_n) = 0,$$

then

$$T(c_1 v_1 + c_2 v_2 + \dots + c_n v_n) = 0.$$

But T is nonsingular and hence

$$c_1 v_1 + c_2 v_2 + \dots + c_n v_n = 0.$$

Since the set $\{v_1, v_2, \dots, v_n\}$ is linearly independent, this then requires that $c_i = 0$, $i = 1, 2, \dots, n$. Hence the set $\{T(v_1), T(v_2), \dots, T(v_n)\}$ is a linearly independent subset of W .

Next, suppose that T maps every linearly independent subset of V onto a linearly

independent subset of W . Let v be any nonzero vector in v . Then the set consisting only of the vector v is a linearly independent subset of V . Thus the set in W consisting only of the vector $T(v)$ must be a linearly independent subset of W and hence must be nonzero. Hence, T is nonsingular.

THEOREM 10: Let V and W be finite-dimensional vector spaces over F , with $\dim V = \dim W = n$. If T is a linear transformation from V into W , then the following are equivalent:

- (i) T is invertible.
- (ii) T is nonsingular.
- (iii) If $\{v_1, v_2, \dots, v_n\}$ is any basis for V , then $\{T(v_1), T(v_2), \dots, T(v_n)\}$ is a basis for W .

PROOF: It should be clear that (i) implies (ii), since the existence of an inverse requires that the transformation be one-to-one.

(ii) implies (iii); for example, assume that T is nonsingular. If $\{v_1, v_2, \dots, v_n\}$ is a basis for V , then the set $\{T(v_1), T(v_2), \dots, T(v_n)\}$ is a linearly independent subset of W . Hence it is part of a basis for W . But any basis of W must contain exactly n vectors. Hence the set $\{T(v_1), T(v_2), \dots, T(v_n)\}$ must be a basis for W .

To show that (iii) implies (i), we must show that for every vector w in W , there is a unique vector v in V such that $T(v) = w$. Since $\{T(v_1), T(v_2), \dots, T(v_n)\}$ is a basis for W , the vector w can be expressed as

$$w = \sum_{j=1}^n c_j T(v_j).$$

Hence the vector $v = \sum_{j=1}^n c_j v_j$ is such that $T(v) = w$. Assume that there is some other vector v_a in V such that $T(v_a) = w$. If v_a is expressed in terms of the basis $\{v_1, v_2, \dots, v_n\}$ as

$$v_a = \sum_{j=1}^n a_j v_j,$$

then

$$T(v_a) = w = \sum_{j=1}^n a_j T(v_j).$$

But the set $\{T(v_1), T(v_2), \dots, T(v_n)\}$ is a basis for W ; hence, any vector in W can be expressed in one and only one way as a linear combination of vectors that form a basis. Hence,

$$a_j = c_j, \quad j = 1, 2, \dots, n;$$

consequently, $v_a = v$.

Theorems 7 and 10 together imply that if we have two finite-dimensional vector spaces V and W of the same dimension, then an invertible linear transformation can always be defined with domain V and range W , by mapping each vector in a set of basis vectors for V , onto a different basis vector in W . When infinite-dimensional vector spaces are discussed, this result will be extended to state that an invertible linear transformation between V and W can always be defined when a one-to-one correspondence can be drawn between basis vectors of V and basis vectors of W , that is, that two vector spaces V and W are isomorphic whenever a one-to-one correspondence can be drawn between basis vectors of V and basis vectors of W .

THEOREM 11: Every n -dimensional vector space V over the field F is isomorphic to the space F^n .

PROOF: Let $\{v_1, v_2, \dots, v_n\}$ be a basis for V . Then every vector v in V is expressible in the form

$$v = \sum_{k=1}^n c_k v_k.$$

Let T , a transformation from V to F^n , be defined as

$$T(v) = (c_1, c_2, \dots, c_n)$$

It can be verified that T is linear, one-to-one, and maps V onto F^n .

THEOREM 12: Let T be a linear transformation from V onto W with null space N . Then the quotient space V/N is isomorphic with W .

PROOF: Let $v + N$ be a coset of V . Define the mapping \tilde{T} from V/N to W as

$$\tilde{T}(v+N) = T(v).$$

We must first show that this mapping is well defined, that is, that $\tilde{T}[(v+n)+N] = \tilde{T}(v+N)$ for any v in V and any n in N . But

$$\tilde{T}[(v+n)+N] = T(v) + T(n) = T(v) = T[v+N],$$

since n is in the null space of T . Hence, \tilde{T} is well defined. \tilde{T} is linear, since

$$\begin{aligned} \tilde{T}[c(v_1+N)+(v_2+N)] &= \tilde{T}[(cv_1+v_2)+N] \\ &= cT(v_1) + T(v_2) \\ &= c\tilde{T}[v_1+N] + \tilde{T}[v_2+N]. \end{aligned}$$

The null space of \tilde{T} is the coset $(0+N)$; for example, assume that $\tilde{T}(v+N) = T(v) = 0$. Then v is in N and hence is in the coset $(0+N)$. Thus \tilde{T} is nonsingular and, by Theorem 10, is then invertible.

2.5 INFINITE-DIMENSIONAL VECTOR SPACES

Many of the theorems that have been presented required that the vector spaces under consideration be finite-dimensional. In Sections III and IV the primary concern will be with infinite-dimensional vector spaces and linear mappings between such spaces. In this section, therefore, infinite-dimensional vector spaces will be considered and some of the important theorems previously discussed for finite-dimensional spaces will be reformulated for the infinite-dimensional case.

Many of the properties of finite-dimensional vector spaces relied on the fact that such spaces, by definition, always possess a countable basis. Theorems such as Theorem 7, for example, rely heavily on the fact that the basis is countable. Although it can be shown in general that any vector space possesses a basis, some of the properties to be discussed in the rest of the report will require that the vector spaces under consideration have countable bases. Hence, the discussion of infinite-dimensional vector spaces to be presented here will be restricted to spaces of countably infinite dimensions.

Even with the restriction that the bases are countable, it is important to reconsider the meaning of a linear combination of an infinite set of vectors. We wish eventually to carry over to the infinite-dimensional case a similar interpretation of the meaning of a basis as a set of vectors spanning the space and providing a unique representation for any vector in the space.

Many of the problems concerned with the extensions to the infinite-dimensional case center around a precise definition of the equality of two vectors. When an inner product is defined on the space, two vectors can be defined to be equal when their difference is a vector of length zero. This definition enables many of the desired extensions to follow in a straightforward manner. An infinite-dimensional inner-product space with certain convergence properties is a Hilbert space. These spaces have been extensively studied and are the most straightforward infinite-dimensional extensions of finite-dimensional vector spaces.

DEFINITION 13: Let H denote an inner-product space. H is defined to be a Hilbert space if for any sequence of vectors in H , $v_1, v_2, \dots, v_n, \dots$ having the property that $\|v_m - v_n\| \rightarrow 0$ as $m, n \rightarrow \infty$, there exists a vector v in H such that $\|v_n - v\| \rightarrow 0$ as $n \rightarrow \infty$.

DEFINITION 14: A sequence of vectors v_n is called an orthonormal basis for a Hilbert space if it is orthonormal and has the property that the only vector in H which is orthogonal to all vectors in the sequence is the zero vector. A Hilbert space with an orthonormal basis is called a separable Hilbert space.

THEOREM 13: If v_n is an orthonormal sequence of vectors in a Hilbert space and

λ_n is a sequence of scalars such that $\sum_1^{\infty} |\lambda_k|^2 < \infty$, then the sequence $w_n = \sum_1^n \lambda_k v_k$

converges to a limit v in H denoted $v = \sum_1^{\infty} \lambda_k v_k$.

PROOF: We must first show that the sequence w_n has the property that $\|w_m - w_n\| \rightarrow 0$ as $m, n \rightarrow \infty$. Letting $m = n + p$ for some integer p , we have

$$\|w_{n+p} - w_n\|^2 = \left\| \sum_{n+1}^{n+p} \lambda_k v_k \right\|^2.$$

Since the sequence v_n is an orthonormal sequence, however,

$$\left\| \sum_{n+1}^{n+p} \lambda_k v_k \right\|^2 = \sum_{n+1}^{n+p} |\lambda_k|^2.$$

But

$$\sum_{n+1}^{n+p} |\lambda_k|^2 = \sum_1^{n+p} |\lambda_k|^2 - \sum_1^n |\lambda_k|^2.$$

Since $\sum_1^{\infty} |\lambda_k|^2 < \infty$, however, we conclude that

$$\sum_{n+1}^{n+p} |\lambda_k|^2 \rightarrow 0 \text{ as } n \rightarrow \infty.$$

Consequently, $\|w_m - w_n\| \rightarrow 0$ as $m, n \rightarrow \infty$; hence, there exists a vector v in H such that $\|w_n - v\| \rightarrow 0$ as $n \rightarrow \infty$, that is, the sequence w_n converges to the limit vector v .

THEOREM 14: Let v_n be an orthogonal sequence of vectors in a Hilbert space.

Given any vector v in H , the scalars $\lambda_k = (v, v_k)$ satisfy the inequality $\sum_1^{\infty} |\lambda_k|^2 < \infty$.

PROOF: Let v_1, \dots, v_j be orthogonal vectors in H . By direct expansion, it can be verified that for any v in H ,

$$\left\| v - \sum_1^j (v, v_k) v_k \right\|^2 = \|v\|^2 - \sum_1^j |(v, v_k)|^2.$$

Since $\left\| v - \sum_1^j (v, v_k) v_k \right\|^2$ must always be greater than or equal to zero, it follows that

$$\|v\|^2 \geq \sum_1^j |(v, v_k)|^2.$$

Since this is true for any j , we have

$$\sum_1^{\infty} |(v, v_k)|^2 = \sum_1^{\infty} |\lambda_k|^2 < \infty.$$

THEOREM 15: If v_n is an orthonormal basis for a Hilbert space H , then each vector v can be expressed as

$$v = \sum_1^{\infty} (v, v_k) v_k.$$

PROOF: We note, first, that the infinite sum is defined in Theorem 13, since the sequence of scalars $\lambda_n = (v, v_n)$ was shown in Theorem 14 to have the required property of being square summable. Consider the vector $w = v - \sum_1^{\infty} (v, v_k) v_k$. We wish to show that this vector is the zero vector. But $(w, v_j) = 0$ for any j , since

$$(w, v_j) = (v, v_j) - (v, v_j) = 0;$$

consequently, the vector $\left[v - \sum_1^{\infty} (v, v_k) v_k \right]$ is orthogonal to every vector in the sequence v_n . From Definition 14, however, the only vector orthogonal to each vector in an orthonormal basis is the zero vector. Hence

$$v - \sum_1^{\infty} (v, v_k) v_k = 0$$

or

$$v = \sum_1^{\infty} (v, v_k) v_k.$$

These theorems provide a framework for the infinite-dimensional Hilbert spaces that are to be considered. Theorem 15 requires the existence of an orthonormal basis for the spaces. This set of basis vectors spans H by virtue of Theorem 15. It can be verified that this set of vectors is linearly independent, by virtue of the property that the only vector orthogonal to the entire set is the zero vector. In general, it is not true that every Hilbert space possesses an orthonormal basis.

An example of a Hilbert space that has an orthonormal basis is the space of square

integrable functions either on the infinite interval $(-\infty, +\infty)$ or on the semi-infinite interval $(0, +\infty)$. This space on the infinite interval is usually denoted $L^2(-\infty, +\infty)$, and on the semi-infinite interval $L^2(0, +\infty)$. An orthonormal basis for $L^2(-\infty, +\infty)$ is the set of Hermite functions. An orthonormal basis for $L^2(0, +\infty)$ is the set of Laguerre functions. In both of these spaces, the inner product is defined as the integral over the interval of the product of the functions.

In the previous discussion on finite-dimensional vector spaces, it was shown that the domain of any linear transformation is a vector space. If the domain of the transformation is a Hilbert space, it is not true in general, however, that the range will also be a Hilbert space. If continuity as defined below is imposed on the transformation, then, as will be seen in the following discussion, the range of the transformation will be a separable Hilbert space if the domain is a separable Hilbert space.

DEFINITION 15: Let V and W be inner product spaces, and T be a linear transformation from V onto W . T is said to be continuous at v if $T(v_n) \rightarrow T(v)$ as $n \rightarrow \infty$ if $v_n \rightarrow v$ as $n \rightarrow \infty$, where v_n is a sequence of vectors in V . T is a continuous transformation if it is continuous at every v in V . Continuity of the transformation T is not a severe restriction when T is linear, for it can be shown that T will always be continuous if it is bounded, that is, if there exists a constant $M > 0$ such that for every vector v in H , $\|T(v)\| \leq M\|v\|$. (See, for example, Berberian.⁸) The set of theorems that follows is chosen to show that the range of a continuous linear transformation is a separable Hilbert space if the domain is a separable Hilbert space. In carrying out the proof the following preliminary results will be demonstrated.

(1) The null space N of T is a closed subspace of H , that is, the limit of any sequence of vectors in N is in N when this limit exists.

(2) From (1), it follows that H can be decomposed into two spaces M and N . The space N is the null space of T , and the space M is the space of all vectors in H which are orthogonal to every vector in N . Any vector in H can then be expressed as a unique linear combination of a vector in M and a vector in N .

(3) On the basis of (2), it will be shown that the quotient space H/N is a separable Hilbert space, and that the linear transformation T from H/N to the range of T is a continuous transformation.

(4) It follows directly from (3) that the range of T is a separable Hilbert space. Steps (1)-(4) will be stated formally in Theorems 16-19. In each of these theorems H denotes a separable Hilbert space, and T denotes a continuous linear transformation with H as the domain.

THEOREM 16: The null space N of T is a closed subspace of H .

PROOF: Let n_1, n_2, \dots be any sequence of vectors in N , and v in H be the limit of this sequence. We wish to show that v is in N . Since n_1, n_2, \dots are in N , $T(n_1) = T(n_2) = \dots = 0$. The limit of any sequence in $T[N]$ is in $T[N]$ because $T[N] = 0$. Since T is continuous, $T(n_p) \rightarrow T(v)$ as $p \rightarrow \infty$, that is, $T(v)$ is the limit of the sequence $T(n_p)$ in $T[H]$. Hence $T(v) = 0$, and v is in N . Thus N is a closed subspace of H .

THEOREM 17: Let M denote the set of all vectors in H which are orthogonal to every vector in N . Then every vector in H can be expressed in one and only one way as the linear combination of a vector in M and a vector in N .

PROOF: Let v be any vector in H . It is stated without proof that there exists a vector n_0 in N such that $\|v-n_0\| \leq \|v-n\|$ for all n in N . (The proof of this statement is found in Berberian.⁹) Define $m_0 = v - n_0$. We must show that m_0 is in M , that is, m_0 is orthogonal to every vector in N .

Let n be any vector in N , and λ equal (m_0, n) . There is no loss in generality if n is assumed to be unity, since, if m_0 is orthogonal to every vector of unit length in N , it is orthogonal to every vector in N . It can be verified by direct expansion that

$$\|m_0 - \lambda n\|^2 = \|m_0\|^2 - |\lambda|^2.$$

Now, $m_0 - \lambda n = (v - n_0) - \lambda n = v - (n_0 + \lambda n)$. But $n_0 + \lambda n$ is in N ; hence,

$$\|v - n_0\| \leq \|v - (n_0 + \lambda n)\|$$

from the choice of n_0 . Hence

$$\|m_0\| \leq \|m_0 - \lambda n\|$$

and therefore

$$\|m_0\|^2 \leq \|m_0\|^2 - |\lambda|^2.$$

Consequently, $|\lambda|^2 = 0$, i. e. $(m_0, n) = 0$. Thus m_0 is in M .

We see, then, that any vector v in H can be written as the sum of a vector m in M and a vector n in N . We must show, next, that for any vector v , m and n are unique. Assume that m_1 and m_2 are in M , n_1 and n_2 are in N , and

$$v = m_1 + n_1 = m_2 + n_2.$$

Then $(m_1 - m_2) + (n_1 - n_2) = 0$. But $m_1 - m_2$ is in M and $n_1 - n_2$ is in N . Taking the inner product of $(m_1 - m_2) + (n_1 - n_2)$ with $(n_1 - n_2)$, we have

$$\|(n_1 - n_2)\|^2 = 0.$$

Similarly,

$$\|(m_1 - m_2)\|^2 = 0.$$

Hence $n_1 = n_2$ and $m_1 = m_2$.

THEOREM 18: The quotient space H/N is a separable Hilbert space, and the linear transformation \tilde{T} from H/N to the range of T is a continuous transformation.

PROOF: To prove that H/N is a separable Hilbert space, we must first define an

inner product in H/N . This can be done with the aid of the preceding theorem.

Let $[v+N]$ be any coset in H/N . Since v can be written uniquely in the form $v = m + n$, the coset $[v+N]$ is equal to the coset $[m+N]$, since n is in N . Furthermore, any coset of the form $[m+N]$ for some m is in H/N . Consequently the set of cosets of the form $[m+N]$ is equal to the quotient space H/N , that is, every coset has a representative element in M . Furthermore, for every coset $[v+N]$ in H/N , there exists only one element m in M such that

$$m + N = v + N,$$

since the component of v in M is unique.

Let $[m_a+N]$ and $[m_b+N]$ be any two cosets in H/N , and define the inner product of these cosets as

$$([m_a+N], [m_b+N]) = (m_a, m_b).$$

It can be verified that this inner product satisfies the required conditions stated in Definition 13. Let $[m_1+N], [m_2+N], \dots$ denote any sequence in H/N having the property that $\|[m_m+N] - [m_n+N]\| \rightarrow 0$ as $m, n \rightarrow \infty$. But $\|[m_m+N] - [m_n+N]\| = \|m_m - m_n\|$, and hence $\|m_m - m_n\| \rightarrow 0$ as $m, n \rightarrow \infty$. Since H is a Hilbert space, there exists a vector v in H such that $\|m_n - v\| \rightarrow 0$ as $n \rightarrow \infty$. In particular, v is in M . This follows directly from the statement without proof, that if n_o is any vector in N , then $(m_n, n_o) \rightarrow (v, n_o)$ as $n \rightarrow \infty$ (the proof of this statement follows from Berberian.¹⁰) Hence $\|[m_n+N] - [v+N]\| \rightarrow 0$ as $n \rightarrow \infty$, and thus H/N is a Hilbert space.

To show that H/N is a separable Hilbert space, we must demonstrate that H/N has an orthonormal basis. Let v_1, v_2, \dots be an orthonormal basis for H , and let

$$v_j = m_j + n_j, \quad m_j \text{ in } M \text{ and } n_j \text{ in } N.$$

Any vector m can be expressed as a linear combination of the m_j , since

$$m = \sum_1^{\infty} c_k v_k = \sum_1^{\infty} c_k m_k + \sum_1^{\infty} c_k n_k.$$

But m can be written in only one way as the sum of a vector in M and a vector in N ; hence, since $m = m + o$, it follows that

$$m = \sum_1^{\infty} c_k m_k.$$

Let m'_1, m'_2, \dots be the subsequence of the sequence m_1, m_2, \dots consisting of all the nonzero elements. Then any vector in M can be expressed as a linear combination of the vectors m'_1, m'_2, \dots . Let

$$m_1'' = m_1' / \|m_1'\|$$

and

$$m_j'' = \frac{\left[m_j' - \sum_{k=1}^{j-1} (m_j', m_k'') m_k'' \right]}{\left\| m_j' - \sum_{k=1}^{j-1} (m_j', m_k'') m_k'' \right\|}.$$

as dictated by the Gram-Schmidt orthogonalization procedure. Then the set m_1'', m_2'', \dots will be an orthonormal basis for M . It follows in a straightforward manner that the cosets $[m_1''+N], [m_2''+N], \dots$ are an orthonormal basis for H/N . Hence, H/N is a separable Hilbert space.

The final step in the proof of this theorem is to show that \tilde{T} is a continuous transformation, that is, we wish to show that if

$$[m_n + N] - [m + N] \rightarrow 0 \quad n \rightarrow \infty,$$

then

$$\tilde{T}[m_n + N] - \tilde{T}[m + N] \rightarrow 0 \quad n \rightarrow \infty.$$

But

$$\tilde{T}[m_n + N] = T[m_n]$$

and

$$\tilde{T}[m + N] = T[m],$$

and, since T is continuous, $T[m_n] - T[m] \rightarrow 0 \quad n \rightarrow \infty$.

THEOREM 19: Let W denote the range of T . Then W is a separable Hilbert space.

PROOF: By virtue of Theorem 18, we need only demonstrate this result for the case in which T is invertible. When T is not invertible we can replace H by H/N , and T by \tilde{T} .

Let w_1 and w_2 be any two vectors in W . Define the inner product of two vectors in W as

$$(w_1, w_2) = (T^{-1}(w_1), T^{-1}(w_2)).$$

We must show that this inner product satisfies the conditions stated in Definition 5.

$$\begin{aligned} (1) \quad (w_1 + w_2, w_3) &= (T^{-1}(w_1 + w_2), T^{-1}(w_3)) \\ &= (T^{-1}(w_1) + T^{-1}(w_2), T^{-1}(w_3)) \\ &= (T^{-1}(w_1), T^{-1}(w_3)) + (T^{-1}(w_2), T^{-1}(w_3)) \\ &= (w_1, w_3) + (w_2, w_3). \end{aligned}$$

$$\begin{aligned}
(2) \quad (cw_1, w_2) &= (T^{-1}(cw_1), T^{-1}(w_2)) \\
&= (cT^{-1}(w_1), T^{-1}(w_2)) \\
&= c(T^{-1}(w_1), T^{-1}(w_2)) \\
&= c(w_1, w_2).
\end{aligned}$$

$$\begin{aligned}
(3) \quad (w_1, w_2) &= (T^{-1}(w_1), T^{-1}(w_2)) \\
&= \overline{(T^{-1}(w_2), T^{-1}(w_1))} \\
&= \overline{(w_2, w_1)}.
\end{aligned}$$

$$(4) \quad (w_1, w_1) = (T^{-1}(w_1), T^{-1}(w_1)) > 0 \quad \text{if } T^{-1}(w_1) \neq 0.$$

But $T^{-1}(w_1) \neq 0$ if $w_1 \neq 0$, and hence $(w_1, w_1) > 0$ if $w_1 \neq 0$. Thus, under this inner product, W is an inner product space. To show that W is a Hilbert space, we must verify Definition 13.

Let $w_1, w_2, \dots, w_n, \dots$ be a sequence of vectors in W having the property that $\|w_m - w_n\| \rightarrow 0$ as $m, n \rightarrow \infty$. From the definition of the inner product in W , $\|w_m - w_n\| = \|T^{-1}(w_m) - T^{-1}(w_n)\|$. Hence the sequence $T^{-1}(w_n)$ in H also has the property that $\|T^{-1}(w_m) - T^{-1}(w_n)\| \rightarrow 0$ as $m, n \rightarrow \infty$. Consequently, since H is a Hilbert space, there exists a vector v in H such that $T^{-1}(w_n) \rightarrow v$ as $n \rightarrow \infty$. Since T is continuous, it follows that $w_n \rightarrow T(v)$ as $n \rightarrow \infty$. Consequently, W is a Hilbert space. We must show, next, that W has an orthonormal basis.

To this end, let v_1, v_2, \dots be an orthonormal basis for H and consider the sequence $T(v_1), T(v_2), \dots$ in W . The vectors in this sequence are orthonormal, since

$$(T(v_i), T(v_j)) = (v_i, v_j).$$

Furthermore, if w is any vector in W , then there exists a unique set of scalars such that

$$T^{-1}(w) = \sum_1^{\infty} c_k v_k$$

or

$$w = \sum_1^{\infty} c_k T(v_k).$$

Thus, the set $T(v_1), T(v_2), \dots$ is an orthonormal basis for W ; consequently, W is a separable Hilbert space.

In Section IV, we shall be concerned with systems described by continuous transformations for which the inputs constitute a separable Hilbert space. The primary result there will be the derivation of a canonic representation of such systems. The result rests heavily on the fact that, by virtue of the preceding theorem, the set of system outputs also constitutes a separable Hilbert space. This fact, in conjunction with the following theorem leads to the canonic representation.

THEOREM 20: Let H_1 and H_2 be two infinite-dimensional Hilbert spaces having orthonormal bases. Then there exists an invertible linear transformation from H_1 onto H_2 .

PROOF: Let v_1, v_2, \dots be an orthonormal basis for H_1 , and w_1, w_2, \dots be an orthonormal basis for H_2 . Define a linear transformation T as

$$T(v) = \sum_1^{\infty} (v, v_k) w_k.$$

We must show that T is linear and invertible, and that its range is all of W . The linearity is easily verified. To show that it is invertible, we must show that its null space is zero, that is, $T(v) = 0$ implies $v = 0$, which follows directly from the linear independence of the orthonormal basis for H_2 . To show that its range is all of W , we must show that if w is any vector in H_2 , then there exists a vector v in H_1 such that

$$T(v) = w.$$

Since H_2 has an orthonormal basis, w can be expressed in the form

$$w = \sum_1^{\infty} (w, w_k) w_k.$$

The sequence $\lambda_k = (w, w_k)$ is square summable, as was shown in Theorem 14. Hence,

from Theorem 13, the sum $\sum_1^{\infty} (w, w_k) v_k$ has a limit vector v in H_1 , that is,

$$v = \sum_1^{\infty} (w, w_k) v_k.$$

But

$$T(v) = \sum_1^{\infty} (w, w_k) T(v_k)$$

and from the definition of T , $T(v_k) = w_k$. Hence,

$$T(v) = \sum_1^{\infty} (w, w_k) w_k = w$$

which was to be shown.

The result of Theorem 20 also applies when H_1 and H_2 are finite dimensional and $\dim(H_1) = \dim(H_2)$

In the Appendix another result concerned with separable Hilbert spaces having time functions as vectors is derived. This result plays an important role in the discussion of Section IV. It is reserved for an appendix rather than developed here because it relies on some of the notation and ideas discussed in Sections III and IV.

From the preceding theorems and definitions it should be clear that a separable Hilbert space is an inner-product space that can be approximated arbitrarily closely by a finite-dimensional inner-product space. If the domain of a linear transformation is a separable Hilbert space and the transformation is continuous, then the outputs can be approximated arbitrarily closely by a finite-dimensional approximation to the input space. Under these restrictions on a linear transformation and its domain, then, all of the results derived for finite-dimensional spaces can be extended directly.

III. GENERALIZED SUPERPOSITION AND HOMOMORPHIC SYSTEMS

3.1 INTRODUCTION

In the past, the concepts of linear algebra have been applied to a restricted class of systems, those that can be represented as linear transformations when vector addition is defined as the sum of the time functions in the vector space of inputs and the vector space of outputs. Because of the principle of superposition which these systems satisfy, they are relatively simple to analyze. This principle of superposition leads to characterization by means of the superposition integral. This representation can be interpreted as resulting from a decomposition of each of the inputs into a linear combination of infinitesimally narrow pulses. These pulses constitute a basis for the vector space of inputs. By virtue of the principle of superposition, the effect of the system on any function in the vector space of inputs is determined from its effect on the basis functions, with the result that the input and output are related through the convolution integral.

Alternatively, the set of complex exponentials of the form e^{st} , where s is a complex number, can be chosen as the set of basis functions for the input vector space. Such functions are eigenfunctions of linear time-invariant systems, and hence such systems have the effect of multiplying these functions by constants. Thus, when complex exponentials are used as a basis for the vector space of inputs to a linear, time-invariant system the system is described by the set of constants by which it attenuates these exponentials, that is, it is described by its system function.

We have noted that vector spaces of time functions could be constructed with a variety of definitions for vector addition. When advantage is taken of the generality afforded by the postulates of vector addition and scalar multiplication, systems that are generally considered to be nonlinear can be represented as linear transformations between vector spaces. Formulated in terms of system theory, this procedure leads to a generalization of the principle of superposition. This principle encompasses the class of linear systems, as well as many nonlinear systems. In particular, it encompasses all invertible systems, as well as many systems that are not invertible.

3.2 GENERALIZED PRINCIPLE OF SUPERPOSITION

A linear system with transformation T is characterized by the property that if $v_1(t)$ and $v_2(t)$ are any two system inputs, then

$$T[c_1 v_1(t) + c_2 v_2(t)] = c_1 T[v_1(t)] + c_2 T[v_2(t)]$$

for any scalars c_1 and c_2 . From this definition, it is clear that the transformation ϕ , defined as

$$\phi[v(t)] = e^{v(t)} \tag{1}$$

is nonlinear, since

$$\phi [c_1 v_1(t) + c_2 v_2(t)] = [\phi(v_1)]^{c_1} [\phi(v_2)]^{c_2}. \quad (2)$$

The transformation of Eq. 1 does obey a form of superposition in the sense that its response to the linear combination of a set of inputs is determined by its response to each of the inputs in the set. The manner in which the individual responses are combined to produce the response to a linear combination of inputs is defined by the right-hand side of Eq. 2.

If the set of inputs to the system of Eq. 1 constitutes a vector space under addition, then the set of outputs constitutes a vector space under multiplication and the transformation of Eq. 1 is an algebraically linear transformation between these spaces. Thus this system falls within the framework of linear algebra.

In order to avoid confusion with the more conventional notion of a linear system, systems that are algebraically linear will be referred to as homomorphic systems, since they are represented by homomorphic transformations between vector spaces. The vector space of inputs to a homomorphic system will be denoted V , and the vector space of outputs will be denoted W . The vector addition of two inputs v_1 and v_2 will be denoted $v_1 \circ v_2$, and the multiplication of an input vector v with a scalar c will be expressed as $(c \succ v)$. The operations \circ and \succ will be referred to as the input operations of the homomorphic system. The vector addition of two outputs w_1 and w_2 will be denoted $w_1 \square w_2$, and the multiplication of an output vector w by a scalar c will be expressed as (c/w) . The operations \square and $/$ will be referred to as the output operations of the system.

A homomorphic system with system transformation ϕ has the property that

$$\phi[(c_1 \succ v_1) \circ (c_2 \succ v_2)] = [c_1 / \phi(v_1)] \square [c_2 / \phi(v_2)] \quad (3)$$

for any inputs v_1 and v_2 and any scalars c_1 and c_2 . The property described by Eq. 3 will be referred to as the generalized principle of superposition. In the particular case for which the operations \circ and \square are chosen to be addition and the operations \succ and $/$ are chosen to be multiplication, Eq. 3 reduces to the principle of superposition as it applies to linear systems.

A homomorphic system with system transformation ϕ , input operation \circ and output operation \square , will be denoted as shown in Fig. 1. An example of a homomorphic system is that system having the transformation specified by Eq. 1. In this case, the operations \circ , \succ , \square , and $/$ are chosen as

$$v_1 \circ v_2 = v_1 + v_2$$

$$c \succ v = cv$$

$$w_1 \square w_2 = w_1 w_2$$

$$c/w = (w)^c.$$

This system is thus represented as shown in Fig. 2.

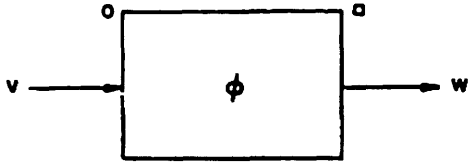

Fig. 1. Representation of a homomorphic system with input operation o , output operation \square , and system transformation ϕ .

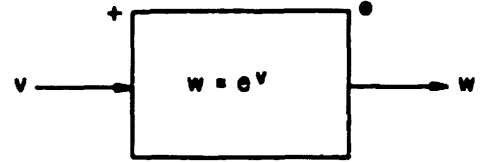

Fig. 2. Example of a homomorphic system with addition as the input operation and multiplication as the output operation.

Since homomorphic systems are represented by linear transformations between vector spaces, algebraic theorems applying to such transformations can be reformulated in terms of homomorphic systems. One of the objectives here will be to discuss the application of these theorems to homomorphic systems.

3.3 INVERTIBLE HOMOMORPHIC SYSTEMS

THEOREM 21: Let ϕ be the system transformation of an invertible system (a system for which the system transformation is invertible) for which the inputs constitute a vector space V with operations o and $>$. Then the system can be homomorphic under, at most, one choice for the output operations.

PROOF: We wish to show that if the system is homomorphic, then the output operations are unique. Assume that there are two sets of output operations under which the system is homomorphic. Let the first set be denoted \square and $/$, and the second set be denoted \blacksquare and \swarrow . If w_1 and w_2 are any two outputs, then we wish to show that $c/w = c\swarrow w$ for all scalars c in the field F and all outputs w .

If we denote the inverse of ϕ by ϕ^{-1} , then if $\phi(v) = w$ it follows that $v = \phi^{-1}(w)$. By assumption, the system ϕ is homomorphic with input operations o and $>$ and output operations \square and $/$. By virtue of Theorem 8, the inverse system, having system transformation ϕ^{-1} , is homomorphic with input operations \square and $/$ and output operations o and $>$. Hence if w_1 and w_2 are any two outputs and c is any scalar in F , we have

$$\phi^{-1}[w_1 \square w_2] = \phi^{-1}(w_1) o \phi^{-1}(w_2) \quad (4)$$

and

$$\phi^{-1}[c/w_1] = c > \phi^{-1}(w_1). \quad (5)$$

By assumption, however, ϕ is also homomorphic with input operations o and $>$ and output operations \blacksquare and \swarrow . Hence ϕ^{-1} is homomorphic with input operations \blacksquare and \swarrow and output operations o and $>$. Consequently,

$$\phi^{-1}[w_1 \oplus w_2] = \phi^{-1}(w_1) \circ \phi^{-1}(w_2) \quad (6)$$

and

$$\phi^{-1}[c \int w_1] = c \int \phi^{-1}(w_1). \quad (7)$$

Comparing Eqs. 4 and 6, we have

$$\phi^{-1}[w_1 \oplus w_2] = \phi^{-1}[w_1 \oplus w_2]. \quad (8)$$

If the vector in V given in Eq. 8 is put through the system ϕ , we have

$$w_1 \oplus w_2 = w_1 \oplus w_2 \quad (9)$$

for all outputs w_1 and w_2 . Similarly, comparing Eqs. 5 and 7, we find

$$\phi^{-1}[c/w_1] = \phi^{-1}[c \int w_1] \quad (10)$$

or

$$c/w_1 = c \int w_1 \quad (11)$$

for all outputs w_1 and all scalars c .

THEOREM 22: Let ϕ be an invertible system the inputs to which constitute a vector space under the operations \circ and \int . Then there always exists a unique set of output operations under which the set of outputs constitutes a vector space, and the system is homomorphic.

PROOF: Let W denote the set of outputs of ϕ . If w_1 and w_2 are any two outputs, let their vector sum be defined as

$$w_1 \oplus w_2 \equiv \phi \left[\phi^{-1}(w_1) \circ \phi^{-1}(w_2) \right]. \quad (12)$$

Similarly, let the scalar multiplication of any output w by a scalar c be defined as

$$c/w \equiv \phi [c \int \phi^{-1}(w)]. \quad (13)$$

We need to verify only that under this choice of output operations, the system ϕ is homomorphic. Theorem 6 then requires that the set of outputs constitutes a vector space under these operations.

Let v_1 and v_2 be any two inputs, and c_1 and c_2 be any two scalars. Then ϕ is homomorphic if

$$\phi[(c_1 \int v_1) \circ (c_2 \int v_2)] = [c_1 / \phi(v_1)] \oplus [c_2 / \phi(v_2)]. \quad (14)$$

Evaluating the right-hand side of Eq. 14 according to Eqs. 12 and 13, we have

$$\begin{aligned}
[c_1/\phi(v_1)] \circ [c_2/\phi(v_2)] &= \left[\phi(c_1 > \phi^{-1}\phi(v_1)) \right] \circ \left[\phi(c_2 > \phi^{-1}\phi(v_2)) \right] \\
&= [\phi(c_1 > v_1)] \circ [\phi(c_2 > v_2)] \\
&= \phi \left[\left(\phi^{-1}\phi(c_1 > v_1) \right) \circ \left(\phi^{-1}\phi(c_2 > v_2) \right) \right]
\end{aligned}$$

or

$$[c_1/\phi(v_1)] \circ [c_2/\phi(v_2)] = \phi[(c_1 > v_1) \circ (c_2 > v_2)]. \quad (15)$$

Hence, ϕ is a homomorphic system.

Furthermore, for a specified input space the set of output operations under which ϕ is homomorphic is unique. This is seen by a direct application of Theorem 21.

Theorem 22 states that the class of homomorphic systems includes all invertible systems. When the input operations and the system transformation are specified, the output operations are given uniquely by Eqs. 12 and 13. In applying the theory of homomorphic systems, it would not be expected that the output operations would be constructed by means of Eqs. 12 and 13, since this would require a precise characterization of the system transformation. Because of the uniqueness of the output operations, however, we know that no matter how these operations are obtained, they must satisfy Eqs. 12 and 13. Equations 12 and 13 allow us to construct examples of homomorphic systems as an aid to developing the theory. By virtue of the uniqueness of the output operations, examples constructed in this way will not depend on a restricted choice for the output operations of the system.

As an example of the application of Eqs. 12 and 13, consider a linear, invertible, time-invariant system. Let $h(t)$ denote the impulse response of the system, and $\tilde{h}(t)$ the impulse response of the inverse system. Let the set of inputs V be a vector space under addition. Since the system was specified to be linear, we know, without application of Eqs. 12 and 13 that the system is homomorphic if vector addition of the outputs is chosen as the sum of the time functions, and scalar multiplication on the output set is chosen as the product of the time function and the scalar.

Since this set of output operations is unique under the specified choice of input operations, application of Eqs. 12 and 13 must yield this result. Specifically, Eq. 12 requires that if w_1 and w_2 are any two outputs, then

$$w_1 \circ w_2 = h(t) \otimes [\tilde{h}(t) \otimes w_1(t) + \tilde{h}(t) \otimes w_2(t)], \quad (16)$$

where \otimes denotes convolution. Expanding Eq. 16,

$$w_1 \circ w_2 = h(t) \otimes \tilde{h}(t) \otimes w_1(t) + h(t) \otimes \tilde{h}(t) \otimes w_2(t),$$

since convolution distributes over addition. The convolution of $h(t)$ and $\tilde{h}(t)$ is the unit

impulse $u_0(t)$; hence,

$$w_1 \square w_2 = u_0(t) \otimes w_1(t) + u_0(t) \otimes w_2(t)$$

or

$$w_1 \square w_2 = w_1(t) + w_2(t).$$

Similarly, Eq. 13 requires that

$$c/w(t) = h(t) \otimes [c(\tilde{h}(t) \otimes w(t))]$$

or

$$c/w(t) = c[h(t) \otimes \tilde{h}(t) \otimes w(t)]$$

and hence

$$c/w(t) = cw(t).$$

As another example of the application of Eqs. 12 and 13, consider the system having the transformation ϕ given by

$$w = \phi(v) = e^v. \tag{17}$$

The transformation corresponding to the inverse system is

$$v = \phi^{-1}(w) = \ln w. \tag{18}$$

If the set of inputs is chosen as a vector space under addition with the field chosen as the field of real numbers, then application of Eq. 12 requires that

$$w_1 \square w_2 = \exp[\ln w_1 + \ln w_2]$$

or

$$w_1 \square w_2 = w_1 w_2 \tag{19}$$

and Eq. 13 requires that

$$c/w = \exp[c \ln w_1]$$

or

$$c/w = [w_1]^c. \tag{20}$$

The transformation of Eq. 17, however, is an invertible transformation under any input vector space. If we choose as the set of inputs, a vector space over the field of real numbers with vector addition defined as the product of the time functions and scalar multiplication defined as the time function raised to the scalar power, then the set of output operations corresponding to the transformation of Eq. 17 will be different from those given in Eqs. 19 and 20. These output operations can, however, be determined

through the use of Eqs. 12 and 13. Applying Eq. 12, the vector sum of any two outputs w_1 and w_2 is given by

$$w_1 \oplus w_2 = e^{[\ln w_1 \ln w_2]}$$

or

$$w_1 \oplus w_2 = \left[e^{\ln w_1} \right]^{\ln w_2}.$$

Similarly, scalar multiplication in the set of outputs is given by

$$c/w = e^{[\ln w]^c}.$$

3.4 NONINVERTIBLE HOMOMORPHIC SYSTEMS

Theorem 22 guarantees that a system that is invertible for an input vector space V , is homomorphic for this set of inputs. When a system is not invertible for a given set of inputs we are no longer assured that the system will be homomorphic with respect to these inputs. Theorems 6 and 12, together with the properties of quotient spaces, lead to necessary and sufficient conditions on the system transformation and the set of inputs associated with a given system such that the system is homomorphic. Before proceeding to a statement of the conditions in terms of a theorem, it would be well to indicate the direction which we take in this theorem.

Consider a system with transformation ϕ and input vector space V . By choosing any subspace N of V , V can be divided into cosets. It is necessary that these cosets be formed with respect to a subspace of V rather than with respect to any arbitrary set of vectors in V , in order that these cosets be well defined. If N is the null space of the system, each vector in a given coset will result in the same output. Furthermore, it will be seen in Theorem 23 that if each vector in a given set of vectors in V maps onto the same vector and if the system is homomorphic, then this set of vectors must be an element in the quotient space V/N . In particular, any coset in V/N which does not map onto the identity element in the vector space of outputs cannot be a subspace of V .

The approach to deriving necessary and sufficient conditions on a system in such a way that it be homomorphic, will be based on a consideration of conditions under which an invertible transformation can be defined from a quotient space associated with V , to the set of outputs of the system. If such an invertible transformation can be defined, then Theorem 22 can be employed to determine a set of output operations under which the system is homomorphic.

THEOREM 23: Let ϕ be the transformation of a system with an input vector space V . Let S_1, S_2, \dots, S_n be subsets of V with the properties that

- (1) All elements in a given set S_j produce the same output. This output corresponding to a set S_j will be denoted $\phi[S_j]$.
- (2) If $\phi[S_i]$ is the output produced by the set of inputs S_i and $\phi[S_j]$ is the output produced by the set S_j , all i and j , then $\phi[S_i] = \phi[S_j]$ implies that $i = j$.

Then, at most, one of the sets S_1, S_2, \dots, S_n can be a subspace of V .

PROOF: Properties (1) and (2) imply that no two sets S_i and S_j have an element in common. For, assume that s is in S_i and s is in S_j , then from property (1),

$$\phi[S_i] = \phi(s)$$

and

$$\phi[S_j] = \phi(s),$$

and hence

$$\phi[S_i] = \phi[S_j],$$

which by virtue of property (2) requires that $i = j$.

Any subspace of V must contain the identity element in V . Hence if two of the sets S_1, S_2, \dots, S_n are subspaces of V , they must both contain the identity element, and hence would have an element in common. Thus, at most, one of the sets S_1, S_2, \dots, S_n can be a subspace of V .

THEOREM 24: Let ϕ be the transformation of a system with an input vector space V . Let S_1, S_2, \dots, S_n be subsets of V with the properties that

- (1) All elements in a given set S_j produce the same output.
- (2) If v is a vector in V , then $\phi(v) = \phi[S_j]$ implies that v is in S_j .
- (3) The sets are distinct; that is, if $\phi[S_i] = \phi[S_j]$, then $i = j$.
- (4) The union of the sets S_1, S_2, \dots, S_n is all of V .

If none of the sets S_1, S_2, \dots, S_n is a subspace of V , then the system cannot be homomorphic.

PROOF: Let e denote the identity element in V and let S_e denote the set of elements such that

$$\phi(e) = \phi(S_e).$$

If ϕ is homomorphic, then the element $\phi(e)$ must be the identity element in the vector space of outputs W by virtue of Theorem 4. Because of property (2) imposed on the sets S_1, S_2, \dots, S_n , the set S_e contains all of the elements in V which map through ϕ to the identity in W . Hence, by definition, S_e is the null space of V and Theorem 6 then requires that S_e be a subspace of V .

Property (4) imposed on the sets S_1, S_2, \dots, S_n requires that this set of subsets of V must contain the subset of all elements of V that map onto $\phi(e)$ and hence must contain S_e . If ϕ is homomorphic, then one of these subsets must be a subspace of V ; hence, if none of these subsets is a subspace of V , then the system cannot be homomorphic.

Theorems 23 and 24 together require that a necessary condition so that a system be homomorphic is that we can find one and no more than one subspace in V which contains all of the elements that map onto a single element in the set of outputs. In general, if the system transformation is well defined, then we are guaranteed that no more than one such subspace can be found. If one such subspace exists, then it must contain the identity element from V . Hence, if e denotes the identity element in V , then Theorem 24 can be reformulated to require that a system with transformation ϕ cannot be homomorphic unless the set of all elements v in V such that $\phi(v) = \phi(e)$ is a subspace of V . As shown in Theorem 25, this condition, together with one other condition, provides necessary and sufficient conditions on a system so that it will be homomorphic.

THEOREM 25: Let ϕ be the system transformation of a system with input vector space V . Then necessary and sufficient conditions so that the system be homomorphic are

- (1) The set of elements S_e in V is a subspace of V , where S_e is the set of all elements s in V with the property that $\phi(s) = \phi(e)$, where e is the identity in V .
- (2) Consider the quotient space V/S_e , where S_e is a subspace of V . Let $v \circ S_e$ be any coset in the quotient space. If v' is any element in $v \circ S_e$, then $\phi(v') = \phi(v)$. (This condition requires that any given coset in the quotient space V/S_e have a unique mapping in W , that is, $\phi[v \circ S_e]$ will be well defined for every v in V , and each coset will produce a different output.)

PROOF: To prove that these two conditions are necessary, we assume that the system is homomorphic and show that this requires that conditions (1) and (2) hold.

Assume that the system is homomorphic. Then, by definition, S_e is the null space of ϕ . Theorem 6 then requires that S_e be a subspace of V . To show that condition (2) is implied by the assumption that the system is homomorphic, let W denote the output vector space with vector addition and scalar multiplication denoted by \square and $/$, respectively. If e is the identity in V , then $\phi(e)$ is the identity in W . Let $v \circ S_e$ be any coset in V/S_e , and v' be an element in $v \circ S_e$. Then there exists some element s of S_e such that

$$v' = v \circ s.$$

Hence $\phi(v) = \phi(v \circ s) = \phi(v) \square \phi(s)$. But, since s is in S_e , $\phi(s)$ is the identity element in W . Consequently,

$$\phi(v') = \phi(v) \quad \text{all } v' \text{ in } v \circ S_e,$$

and therefore condition (2) holds.

To show that conditions (1) and (2) are sufficient, we shall assume that these conditions hold, and prove that the system must then be homomorphic. Condition (1) permits the construction of a quotient space with respect to the set S_e , since it requires that this set be a subspace of V . Condition (2) then provides an invertible transformation between the quotient space V/S_e and the set of outputs W , since for any coset

$v \circ S_e$ in the quotient space V/S_e there exists a well-defined mapping to an element in W given by

$$\tilde{\phi}[v \circ S_e] \equiv \phi(v).$$

The transformation $\tilde{\phi}$ can then be considered as the system transformation associated with an invertible system with inputs that are elements in the quotient space V/S_e . Theorem 22 requires that the system with transformation $\tilde{\phi}$ be a homomorphic system and that the set of outputs W be a vector space. Specifically, vector addition in the set of outputs is defined by

$$w_1 \square w_2 = \tilde{\phi} \left[\tilde{\phi}^{-1}(w_1) \circ \tilde{\phi}^{-1}(w_2) \right], \quad (21)$$

where w_1 and w_2 are any two elements in W . The elements $\tilde{\phi}^{-1}(w_1)$ and $\tilde{\phi}^{-1}(w_2)$ are cosets in the quotient space V/S_e . Scalar multiplication in W is defined as

$$c/w = \tilde{\phi} [c \triangleright \tilde{\phi}^{-1}(w)]. \quad (22)$$

It remains only to show that with this choice of output operations the system with system transformation ϕ and input vector space V , is homomorphic. Let v_1 and v_2 be any two elements in V . Then

$$\phi(v_1) = \tilde{\phi} [v_1 \circ S_e],$$

$$\phi(v_2) = \tilde{\phi} [v_2 \circ S_e],$$

$$\phi(v_1 \circ v_2) = \tilde{\phi} [(v_1 \circ v_2) \circ S_e].$$

From the definition of vector addition in the quotient space V/S_e as stated in Theorem 3, however,

$$(v_1 \circ v_2) \circ S_e = (v_1 \circ S_e) \circ (v_2 \circ S_e);$$

hence,

$$\phi(v_1 \circ v_2) = \tilde{\phi} [(v_1 \circ S_e) \circ (v_2 \circ S_e)].$$

Since $\tilde{\phi}$ is homomorphic,

$$\tilde{\phi} [(v_1 \circ S_e) \circ (v_2 \circ S_e)] = \tilde{\phi} [v_1 \circ S_e] \square \tilde{\phi} [v_2 \circ S_e].$$

By definition of $\tilde{\phi}$, however,

$$\tilde{\phi} [v_1 \circ S_e] = \phi(v_1)$$

$$\tilde{\phi}[v_2 \circ S_e] = \phi(v_2).$$

Consequently,

$$\phi(v_1 \circ v_2) = \tilde{\phi}[v_1 \circ S_e] \circ \tilde{\phi}[v_2 \circ S_e] = \phi(v_1) \circ \phi(v_2). \quad (23)$$

Next, let v be any element in V , and c any scalar in the field. Then

$$\phi(v) = \tilde{\phi}[v \circ S_e]$$

$$\phi(c \circ v) = \tilde{\phi}[(c \circ v) \circ S_e].$$

From the definition of scalar multiplication in V/S_e , however,

$$(c \circ v) \circ S_e = c \circ (v \circ S_e);$$

hence,

$$\phi(c \circ v) = \tilde{\phi}[c \circ (v \circ S_e)].$$

But, since $\tilde{\phi}$ is homomorphic,

$$\tilde{\phi}[c \circ (v \circ S_e)] = c \circ \tilde{\phi}(v \circ S_e)$$

or

$$\tilde{\phi}[c \circ (v \circ S_e)] = c \circ \phi(v)$$

Therefore

$$\phi(c \circ v) = c \circ \phi(v). \quad (24)$$

Equations 23 and 24 are sufficient for the system to be homomorphic.

THEOREM 26: Let ϕ be a homomorphic system with input vector space V and null space N . Let the subset S of V be defined by the properties

- (1) If s_1 and s_2 are any two elements in S , then $\phi(s_1) = \phi(s_2)$.
- (2) If s is in S and v is in V , then $\phi(s) = \phi(v)$ implies that v is in S .

Then each such subset is a distinct coset in V/N . In particular, each subset S is the coset $s \circ N$, where s is any element in S .

PROOF: Let S be any subset of V having properties (1) and (2). Consider the coset $s \circ N$, where s is in S . Let $s \circ n$ be any element in this coset. Then $\phi(s \circ n) = \phi(s) \circ \phi(n)$, since ϕ is homomorphic. But $\phi(n)$ is the identity in the output set W , since n is in the null space. Hence

$$\phi(s \circ n) = \phi(s);$$

consequently, $s \circ n$ is in S by virtue of property (2). Thus the coset $s \circ N$ is contained in the set S .

We must show next that the set S is contained in the coset $s \circ N$. Let s_1 be any element in S . Then s_1 can be expressed as

$$s_1 = s \circ (s^{-1} \circ s_1).$$

But $s^{-1} \circ s_1$ is in the null space N , since

$$\phi(s) = \phi(s_1),$$

and the system is homomorphic. Hence for any s_1 in S , there exists an n_1 in N such that

$$s_1 = s \circ n_1;$$

consequently, s_1 is in the coset $s \circ N$. Thus S is contained in $s \circ N$ and therefore

$$S = s \circ N.$$

The fact that each of these cosets is distinct follows directly from property (2) and Theorem 4.

Theorems 25 and 26 provide a procedure for investigating whether or not a given system is homomorphic. Specifically, according to Theorem 25, we first find all elements in the input-vector space V which produce the same output as that produced by the identity element in V . If this set is not a subspace of V , then the system cannot be homomorphic. If it is a subspace of V , we must then determine whether or not every coset constructed by adjoining each vector in V to the null space has a unique output. If each of these cosets has a unique mapping, then the system is homomorphic. If not, the system cannot be homomorphic. Alternatively, the second condition can be reformulated in terms of Theorem 25. The input vector space can be divided into all of those sets that produce unique outputs in W . The system is only homomorphic if each of these sets is a coset in the space V/S_e , where S_e is the subspace of V defined previously.

As an example of the application of this procedure, consider an invertible system with input vector space V and system transformation ϕ . Since the system is invertible, the set S_e contains only the identity in V . The identity alone constitutes a subspace; hence, the first condition of Theorem 25 is met. Each of the cosets in the quotient space V/S_e when S_e is the identity alone contain only a single vector; specifically, the coset $v \circ S_e$ contains only the vector v . Thus all of the vectors in any given coset produce the same output and each coset is associated with a different output. Consequently the second condition of Theorem 25 is satisfied. Alternatively, if we interpret the second condition of Theorem 25 by means of Theorem 26, we can divide V into sets defined by the property that any given set contains all of the inputs that produce a given output. Again, since the system is invertible, each of these sets contains a single vector from V . These are the cosets in V/S_e , and hence by this interpretation, the

second condition of Theorem 25 is satisfied. It can be ascertained that when S_e consists of the identity alone, which by Theorem 10 is a necessary and sufficient condition for a homomorphic system to be invertible, Eqs. 21 and 22 reduce to Eqs. 12 and 13. It follows, then, that as we have already shown by other means, any invertible system is homomorphic.

As another example of the application of Theorem 25, consider a system with transformation ϕ defined as

$$\phi(v) = v^2.$$

Let us choose the input vector space V to be a space under addition and require that it contain more than just the identity element. Since the identity element in V is the element 0, the set S_e is the set of all elements s in V with the property that

$$\phi(s) = \phi(0) = 0.$$

From Eq. 25 we see that there is no element in V other than the identity which will produce zero output; hence, the set S_e contains the identity alone. The identity is a subspace of V ; hence, the first condition of Theorem 26 is met. Because the set S_e is the identity alone, the coset $v \circ S_e$ in V/S_e is the vector v . But the coset $v \circ S_e$ and $(-v) \circ S_e$ produces the same output; hence, condition (2) of Theorem 26 is not met. Thus the given system is not homomorphic.

As a third example, consider the system with transformation ϕ defined by

$$\phi(v) = \frac{1}{v} \frac{dv}{dt}. \quad (25)$$

Let the input vector space be chosen as a space under multiplication, in which case the identity e in V is $e = 1$. The set S_e is then the set of all elements s in V such that

$$\frac{1}{s} \frac{ds}{dt} = 0,$$

which is the set of all constant inputs in V . It can be verified that this set is a subspace of V . Now, consider any coset $v \circ S_e$. We must show that all elements of the form $v \cdot c$, where c is a constant, produce the same output, for any c . But

$$\phi(v \cdot c) = \frac{1}{v \cdot c} \frac{d}{dt} (v \cdot c) = \frac{1}{v} \frac{dv}{dt}$$

and hence $\phi(v \cdot c)$ is independent of c , as required. We must then ascertain that each distinct coset is associated with a different output. In Theorem 4 we noted that if two cosets have any element in common, they are identical cosets. Conversely, if two cosets differ by at least one element, then they will have no elements in common. Consider two distinct cosets $v_1 \circ S_e$ and $v_2 \circ S_e$. Then

$$\phi[v_1 \circ S_e] = \frac{1}{v_1} \frac{dv_1}{dt} = \frac{d}{dt} [\ln v_1]$$

and

$$\phi[v_2 \circ S_e] = \frac{1}{v_2} \frac{dv_2}{dt} = \frac{d}{dt} [\ln v_2].$$

The system with the transformation of Eq. 25 will be homomorphic if and only if

$$\phi[v_1 \circ S_e] = \phi[v_2 \circ S_e] \quad (26)$$

implies that $v_1 \circ S_e$ and $v_2 \circ S_e$ are identical cosets, i. e. that v_1 is a scalar multiple of v_2 . But Eq. 26 requires that

$$\frac{d}{dt} [\ln v_1] = \frac{d}{dt} [\ln v_2]$$

or

$$\ln v_1 = \ln v_2 + c$$

for some constant c . Hence

$$v_1 = c' v_2 \quad (27)$$

for some constant c' ; therefore, we conclude that the system is homomorphic.

In Theorem 22 we investigated the necessary and sufficient conditions on an invertible system such that a set of output operations could be selected to make the system homomorphic. These output operations were shown to be unique. Similarly, in Theorem 25 necessary and sufficient conditions on a noninvertible system were given so that the system was homomorphic. It was shown that when these conditions were met, and the output operations were chosen according to Eqs. 21 and 22, then the system would be homomorphic. As for an invertible system, it can be shown that the output operations chosen according to Eqs. 21 and 22 are a unique choice.

THEOREM 27: Let ϕ be the system transformation of a (not necessarily invertible) system, with input vector space V . Then there is, at most, one choice for the output operations under which the system is homomorphic.

PROOF: The desired result can be shown by assuming that the system is homomorphic under more than one choice for the output operations, and from this deriving a contradiction.

Specifically, let W denote the set of outputs. Let N_1 denote the null space of the system when the output operations are \square and $/$, and let N_2 denote the null space of the system when the output operations are \blacksquare and \surd . If e denotes the identity in V , then N_1 contains all of the elements n in V , with the property that $\phi(n) = \phi(e)$. Similarly, N_2 contains all of the elements n' in V such that $\phi(n') = \phi(e)$. Hence, $N_1 = N_2$, that is, the null spaces under the two choices for the output operation are identical. Let N_1 and N_2 both be denoted by N , and consider the quotient space V/N . Theorem 12 requires that the system having the space V/N as the input space and the space W as the output

space be an invertible homomorphic system. If the original system had more than one choice for the output operations, however, this invertible system would also have more than one choice for the output operations, which contradicts Theorem 22.

Because of Theorem 27, the output operations of a homomorphic system which are constructed according to Eqs. 21 and 22 represent a unique choice for these operations. Consider, for example, the system having the transformation of Eq. 26, with the input vector space being a space under multiplication. It has been determined that this system is homomorphic. An element $v \in N$ in the space V/N , where N is the null space, is the set of elements in V that are scalar multiples of v . The mapping $\tilde{\phi}$ from V/N to W , and the inverse of $\tilde{\phi}$ are defined by

$$\tilde{\phi}[cv] = \frac{1}{v} \frac{dv}{dt} = w$$

and

$$\tilde{\phi}^{-1}(w) = e^{\int w dt} = [cv].$$

Using Eqs. 21 and 22, we find that the output operations of the system must be

$$\begin{aligned} w_1 \square w_2 &= \tilde{\phi} \left[\tilde{\phi}^{-1}(w_1) \tilde{\phi}^{-1}(w_2) \right] \\ &= \frac{d}{dt} \ln \left[\left(e^{\int w_1 dt} \right) \left(e^{\int w_2 dt} \right) \right] = w_1 + w_2 \end{aligned}$$

and

$$c/w_1 = \frac{d}{dt} \ln \left[\left(e^{\int w_1 dt} \right)^c \right] = cw_1$$

for any w_1 and w_2 in W , and any scalar c in the field.

IV. CANONIC REPRESENTATION FOR HOMOMORPHIC SYSTEMS

4.1 INTRODUCTION

The class of homomorphic systems has been introduced. The generalized principle of superposition which is satisfied by these systems is similar in form to the principle of superposition describing a linear system; when the input and output operations of a homomorphic system are addition, the system is linear and the generalized principle of superposition reduces to the statement of superposition in its usual form.



Fig. 3. Homomorphic system with multiplication as the input operation and output operation.

A canonic representation for homomorphic systems will now be derived. This representation amounts to a substitution of variables which reduces the system to a linear system. For any

particular homomorphic system the input and output variables that are chosen so that the equivalent system will be linear, are dependent only on the input vector spaces, and not on the details of the homomorphic mapping between these spaces.

As an example of the form that the canonic representation takes, consider a homomorphic system having multiplication as both the input operation and the output operation, as indicated in Fig. 3. This system has the property that for any two inputs v_1 and v_2 and any scalar c ,

$$\phi[v_1^c v_2] = [\phi(v_1)]^c \phi(v_2) = w_1^c w_2, \quad (28)$$

where $w_1 = \phi(v_1)$, and $w_2 = \phi(v_2)$.

If we perform the substitution of variables

$$x = \ln v \quad (29)$$

and

$$y = \ln w, \quad (30)$$

then the relation between x and y becomes

$$e^y = \phi(e^x)$$

or

$$y = \ln [\phi(e^x)] \equiv \phi'(x) \quad (31)$$

But the transformation ϕ' is linear because if x_1 and x_2 are any two inputs and c is any scalar

$$\phi'[cx_1 + x_2] = c\phi'(x_1) + \phi'(x_2).$$

Hence by the substitution of variables defined by Eqs. 29 and 30, the system has been reduced to a linear system. The system of Fig. 3 is thus representable in the form of Fig. 4 where the linear transformation ϕ' is defined by Eq. 31. In the representation

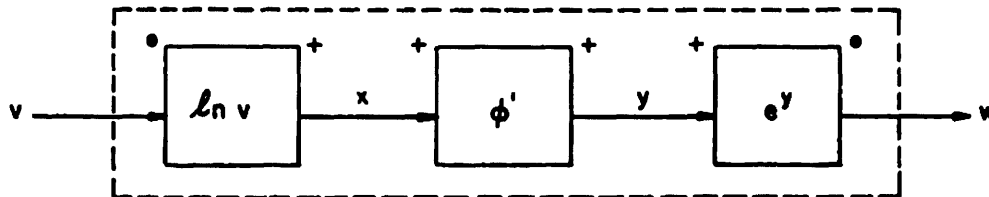

Fig. 4. Equivalent representation of the system of Fig. 3.

in Fig. 4, the first and last systems depend only on the input and output vector spaces; they do not depend on the details of the transformation ϕ . We notice also for this particular example, that all of the memory in the system of Fig. 3 is concentrated in the linear system ϕ' of Fig. 4, since the first and last systems in this representation are memoryless. Here we shall derive necessary and sufficient conditions under which this can be done.

4.2 CANONIC REPRESENTATION

In the example just presented, a homomorphic system was reduced to a linear system by means of a substitution of variables. This essentially requires a mapping of the vector space of inputs onto a vector space under addition, in a one-to-one manner. Similarly, the vector space of outputs must also be mapped onto a vector space under addition in a one-to-one manner. Our objective now is to show that for any vector space such a mapping exists, and to discuss the resulting representation.

Let us restrict the system inputs to constitute a Hilbert space with an orthonormal basis, and restrict the system transformation to be a continuous homomorphic transformation. Under these restrictions, the system outputs will also constitute a Hilbert space with an orthonormal basis. This is equivalent to assuming that the input and output spaces can be approximated arbitrarily closely by finite dimensional spaces. By virtue of Theorem 20, both the input vector space and the output vector space are isomorphic with any infinite dimensional Hilbert space having an orthonormal basis. In particular, each of these spaces will be isomorphic with a Hilbert space in which vector addition is interpreted as the sum of the corresponding time functions, for example, the space of functions that are square integrable. Thus we can always define an invertible

homomorphic system that maps the inputs onto a Hilbert space under addition, and an invertible homomorphic system that maps the outputs onto a Hilbert space under addition.

Consider a homomorphic system, then, with input vector space V which is a Hilbert space with an orthonormal basis, output vector space W , and continuous system transformation ϕ . Let α_0 denote the system transformation of an invertible homomorphic

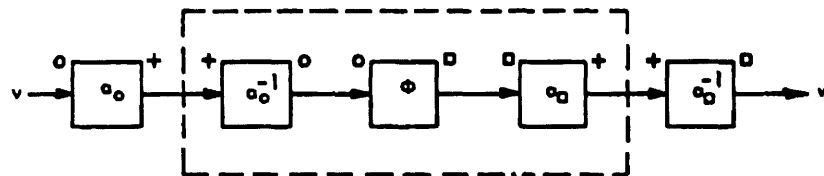

Fig. 5. Equivalent representation of a homomorphic system.

system with V as the input vector space, and a vector space under addition, denoted by V_+ , as the output vector space. Similarly, let α_0 denote the system transformation of an invertible homomorphic system with W as the input vector space, and a vector space under addition, denoted by W_+ , as the output vector space. Since the systems α_0 and

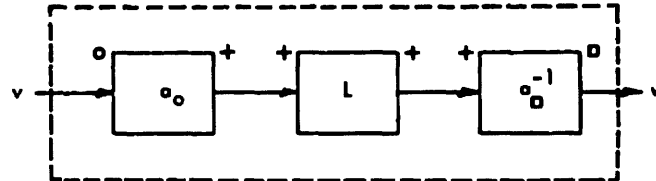

Fig. 6. Canonic representation of a homomorphic system.

α_0 are invertible, the system ϕ can be represented in the form shown in Fig. 5. The system enclosed in the dotted lines, however, is a linear system and hence the system of Fig. 5 can be redrawn in the form of Fig. 6, where L is a linear system. We recognize furthermore that the system of Fig. 6 is a homomorphic system with V as the input vector space and W as the output vector space, for any choice of the linear system L . The representation of Fig. 6 will be referred to as a canonic representation of homomorphic systems.

An example of the canonic representation of a homomorphic system was shown in Fig. 4. In this case the homomorphic system had multiplication as both the input and output operations. An example of such a system is that system having a transformation ϕ defined as

$$\phi(v) = v^k, \quad k \text{ a real number.}$$

In this case, the canonic representation takes the form of Fig. 7. To obtain any

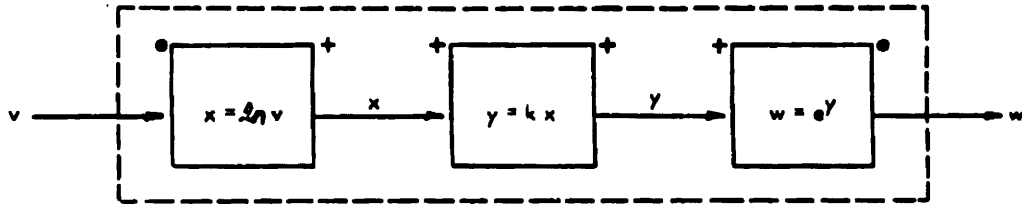

Fig. 7. Canonic representation of a homomorphic system with transformation $\phi[v] = v^k$.

homomorphic system having the same input and output vector spaces as the system of Fig. 7, we need only replace the amplifier of gain k with other linear systems.

From the form of the canonic representation, we recognize it as a substitution of variables which reduces a homomorphic system to a linear system. The particular choice for the substitution of variables associated with any specified homomorphic system is governed only by the input vector space and output vector space associated with the system. The details of the mapping between these spaces is then contained in the linear system L .

4.3 CLASSIFYING HOMOMORPHIC SYSTEMS

The canonic representation suggests a means for classifying homomorphic systems. Specifically, let us classify homomorphic systems according to their input and output spaces. Since the characteristic systems α_0 and α_1 are determined entirely by the input vector space and output space associated with the homomorphic system, all systems within a specified class will have identical systems α_0 and α_1 in the canonic representation. The systems within each class will differ only in the details of the linear system appearing in this representation.

As a simple example of this means of classifying homomorphic systems, we would consider all linear systems as representing one class of homomorphic systems. Another class of homomorphic systems would be the class having the characteristic systems that appear in the representation of Fig. 7. In this case vector addition is defined as multiplication of the associated time functions, and scalar multiplication is defined as the associated time function raised to the scalar power.

4.4 CONDITIONS ON A HOMOMORPHIC SYSTEM SUCH THAT THE CHARACTERISTIC SYSTEMS ARE MEMORYLESS

In the class of homomorphic systems characterized by multiplication as both the input operation and the output operation, we observe that the characteristic systems α_0 and α_1 are memoryless systems, i. e., that output of each at any given instant of time is dependent only on the input at the same instant of time. Hence, for this particular class of systems, all of the system memory can always be concentrated in the linear

system in the canonic representation.

The question arises as to the conditions on a class of homomorphic systems under which the characteristic systems α_o and α_{\square} are memoryless. Since these systems represent invertible mappings from the input and output vector spaces respectively we wish to determine the necessary and sufficient conditions on a vector space consisting of time functions, such that a memoryless, invertible, homomorphic mapping to a vector space under addition can be constructed. In the following discussion it will be shown that the necessary and sufficient conditions are that the operations of vector addition and scalar multiplication must themselves be memoryless.

To show first of all that these conditions on the vector space are necessary, consider an invertible homomorphic system with transformation α_o , input vector space V and output vector space W . Let the operation of vector addition in V be denoted by \circ and the operation of scalar multiplication in V be denoted by $>$. Let W be a vector space under addition. Then by virtue of Theorem 22, vector addition and scalar multiplication in V must be expressible uniquely as

$$v_1 \circ v_2 = \alpha_o^{-1} [\alpha_o(v_1) + \alpha_o(v_2)] \quad (32)$$

$$c > v_1 = \alpha_o^{-1} [c \alpha_o(v_1)] \quad (33)$$

for any v_1 and v_2 in V and any scalar c . Let us denote the instantaneous value of a vector v in V at a time t_1 by $v|_{t_1}$. Then we wish to determine whether Eqs. 32 and 33 require that the operations \circ and $>$ be defined on the instantaneous value of v_1 and v_2 if α_o is memoryless. Consider first, Eq. 32. Since α_o is memoryless, its inverse α_o^{-1} is also memoryless. Hence, the right-hand side of (32) is defined on the instantaneous values of v_1 and v_2 . Hence, the left-hand side of (33) must also be defined on instantaneous values of v_1 and v_2 . We must next ascertain that

$$[v_1 \circ v_2]|_{t_1} = (v_1|_{t_1}) \circ (v_2|_{t_1}). \quad (34)$$

But

$$[v_1 \circ v_2]|_{t_1} = \left\{ \alpha_o^{-1} [\alpha_o(v_1) + \alpha_o(v_2)] \right\} |_{t_1} \quad (35)$$

and

$$(v_1|_{t_1}) \circ (v_2|_{t_1}) = \alpha_o^{-1} [\alpha_o(v_1|_{t_1}) + \alpha_o(v_2|_{t_1})]. \quad (36)$$

But, since α_o is memoryless, Eq. 36 becomes

$$(v_1|_{t_1}) \circ (v_2|_{t_1}) = \alpha_o^{-1} [\alpha_o(v_1)|_{t_1} + \alpha_o(v_2)|_{t_1}].$$

Since addition is memoryless, we see that

$$(v_1|t_1) \circ (v_2|t_1) = a_o^{-1}([a_o(v_1)+a_o(v_2)]|t_1).$$

Finally, since a_o^{-1} is memoryless,

$$(v_1|t_1) \circ (v_2|t_1) = a_o^{-1}[a_o(v_1)+a_o(v_2)]|t_1. \quad (37)$$

Comparing Eqs. 35 and 37, we see that

$$[v_1 \circ v_2]|t_1 = (v_1|t_1) \circ (v_2|t_1)$$

whenever a_o is a memoryless system. Similarly, we wish to show that the assumption that a_o is memoryless implies that $>$ is memoryless, that is

$$[c_{>}v_1]|t_1 = [c_{>}(v_1|t_1)]. \quad (38)$$

Referring to Eq. 33, we see that the operation $>$ is defined on instantaneous values of v_1 , since a_o is memoryless. To show that (38) is satisfied, we observe that because scalar multiplication is memoryless and a_o is memoryless,

$$a_o^{-1}[c_{a_o}(v_1|t_1)] = \{a_o^{-1}[c_{a_o}(v_1)]\}|t_1. \quad (39)$$

But, the left-hand side of (39) is

$$a_o^{-1}[c_{a_o}(v_1|t_1)] = c_{>}(v_1|t_1)$$

and the right-hand side of (39) is

$$\{a_o^{-1}[c_{a_o}(v_1)]\}|t_1 = [c_{>}(v_1)]|t_1. \quad (40)$$

Comparing Eqs. 39 and 40, we see then that Eq. 38 is satisfied; consequently, $>$ is a memoryless operation. Hence, a necessary condition on the vector space V so that a_o is a memoryless system is that the operations \circ and $>$ must be memoryless operations. The next step is to show that this also constitutes a sufficient condition. To this end, let V be a vector space with vector addition denoted \circ and scalar multiplication denoted $>$. Elements of the vector space are time functions, that is, they are scalars indexed over time t . Vector addition and scalar multiplication in V are assumed to be memoryless, that is, at any value of t ,

$$(v_1 \circ v_2)|t = (v_1|t) \circ (v_2|t) \quad (41)$$

$$(c_{>}v)|t = c_{>}(v|t) \quad (42)$$

for any v_1 and v_2 in V and any scalar c in F . Let e denote the identity in V .

Consider the set of all scalar values which the time functions in V can assume at an

instant of time t . Let this set be denoted S_t . Then the set S_t is itself a vector space, for

- (a) Let η_1 and η_2 be any scalars in S_t . Then there is a vector v_1 in V and v_2 in V such that $v_1|_t = \eta_1$ and $v_2|_t = \eta_2$. Since V is a vector space, $v_1 \circ v_2$ is in V ; hence, $(v_1 \circ v_2)|_t$ is in S_t . But from Eq. 41, $(v_1 \circ v_2)|_t = (\eta_1 \circ \eta_2)$; hence, $(\eta_1 \circ \eta_2)$ is in S_t . By similar reasoning, it can be seen that $\eta_1 \circ \eta_2 = \eta_2 \circ \eta_1$ and that $(\eta_1 \circ \eta_2) \circ \eta_3 = \eta_1 \circ (\eta_2 \circ \eta_3)$ for any η_1, η_2 and η_3 in S_t .
- (b) There is a unique element e_t in S_t such that $\eta \circ e_t = \eta$ for any η in S_t . To show the existence of such an element, let v be an element in V such that $v|_t = \eta$. If e is the identity in V , then $v \circ e = v$. Hence $(v \circ e)|_t = v|_t$, or $(v|_t) \circ (e|_t) = v|_t$. Since $v|_t = \eta$, we have

$$\eta \circ (e|_t) = \eta.$$

Thus $e|_t$ will be an element in S_t such that $\eta \circ (e|_t) = \eta$, that is, $e_t = e|_t$. To show that the element e_t in S_t is unique, consider two elements e_t and e'_t in S_t with the property that

$$\eta \circ e_t = \eta \tag{43}$$

and

$$\eta \circ e'_t = \eta \tag{44}$$

for all η in S_t . Then, by virtue of (43),

$$e'_t \circ e_t = e'_t \tag{45}$$

and by virtue of (44),

$$e_t \circ e'_t = e_t. \tag{46}$$

But we have stated that \circ was a commutative operation in S_t ; hence,

$$e_t \circ e'_t = e'_t \circ e_t.$$

Therefore, from Eqs. 45 and 46, $e_t = e'_t$.

- (c) Every element η in S_t has a unique inverse in S_t . For, let v be the vector in V such that $v|_t = \eta$. Then, if v^{-1} denotes the inverse of v in V , we have $v \circ v^{-1} = e$; hence, $(v|_t) \circ (v^{-1})|_t = e|_t$, or $\eta \circ (v^{-1})|_t = e_t$. Denoting $(v^{-1})|_t$ by η^{-1} , we have $\eta \circ \eta^{-1} = e_t$. To show that this inverse is unique, let η^{-1} and η_1^{-1} denote two elements in S_t such that $\eta \circ \eta^{-1} = e_t$ and $\eta \circ \eta_1^{-1} = e_t$. Then if $\eta = v|_t$, $\eta^{-1} = v^{-1}|_t$ and $\eta_1^{-1} = v_1^{-1}|_t$, it follows that

$$(v \circ v^{-1})|_t = (v \circ v_1^{-1})|_t.$$

If v_1^{-1} is chosen by considering all possible values for t , then $v \circ v^{-1} = v \circ v_1^{-1} = \epsilon$. But the inverse of v is unique; hence $v_1^{-1} = v^{-1}$ for all values of t ; in particular, $v_1^{-1}|_t = v^{-1}|_t$ or $\eta_1^{-1} = \eta^{-1}$.

- (d) The final step in showing that S_t is a vector space is to show that scalar multiplication in S_t has the necessary properties. If η is any element in S_t , where $\eta = v|_t$, then $1_{>}\eta = 1_{>}v|_t = (1_{>}v)|_t = v|_t$; hence, $1_{>}\eta = \eta$. By a similar argument it can be seen that

$$(c_1 c_2)_{>}\eta = c_{1>}(c_{2>}\eta)$$

and

$$(c_1 + c_2)_{>}\eta = (c_{1>}\eta) \circ (c_{2>}\eta),$$

for any c_1 and c_2 , and

$$c_{>}(\eta_1 \circ \eta_2) = (c_{>}\eta_1) \circ (c_{>}\eta_2),$$

for any η_1 and η_2 in S_t and any c .

If V is a separable Hilbert space, as we have assumed, the vector space S_t is isomorphic with the space F^n , where n is the dimension of S_t (see the Appendix). Let this isomorphism be denoted α_t . Define a vector space W having elements that are n -tuples indexed over time, that is, if w is in W , then $w|_t$ is representable in the form (c_1, c_2, \dots, c_n) , where c_1, c_2, \dots, c_n are elements of the field. Then W is a vector space under addition, since n -tuples are added and multiplied by scalars according to the operations of addition and multiplication in the field. Now, there is a mapping α from V onto W which is invertible and homomorphic. Specifically, let α be defined by the property that $[\alpha(v)]|_t = \alpha_t(v|_t)$ for any value of t . Then α is also a memoryless transformation; consequently, it has the properties that we set out to derive. Hence we have shown that a sufficient condition on a vector space V so that a memoryless, homomorphic, invertible transformation from V to a vector space under addition exists is that the operations of vector addition and scalar multiplication in V be memoryless.

To summarize, we see that in the canonic representation of a homomorphic system the system α_o can be memoryless if and only if the operations \circ and $>$ are memoryless operations. Similarly, the system α_\square (or equivalently α_\square^{-1}) can be memoryless if and only if the operations \square and $/$ are memoryless operations. In the canonic representation for systems in a class specified by memoryless input and output operations, all of the memory in the systems can always be concentrated in the linear portion of the canonic representation. In contrast, if either the set of input operations or the set of output operations is not memoryless, then the memory of systems in such classes can never be concentrated only in the linear portion of the canonic representation.

Before proceeding to some examples of the construction of memoryless invertible homomorphic transformations from the input and output vector spaces of a homomorphic

system to spaces under addition, it would be well to investigate in more detail, the properties of these transformations and the consequences in terms of the canonic representation.

When the canonic representation was first presented, the linear system was interpreted as a system having a single input and a single output. We have seen, however, that when we desire the systems α_0 and α_0^{-1} to be memoryless systems, the input and output of the linear system may not be a simple time function, that is, they may not simply be a set of scalars indexed over time. Specifically, consider a homomorphic system with memoryless input and output operations. Consider this system in its canonic representation with the systems α_0 and α_0^{-1} constructed to be memoryless. Then the output of α_0 will be of the form $(f_1(t), f_2(t), \dots)$, where $f_1(t), f_2(t) \dots$ are each scalars indexed over time. Similarly, the set of inputs to α_0^{-1} will be of the form $(g_1(t), g_2(t), \dots)$, where $g_1(t), g_2(t), \dots$ are each scalars indexed over time. In this case, we would interpret the system α_0 as a memoryless system having a single input and multiple outputs. For any input v the individual outputs would be the time functions $f_1(t), f_2(t), \dots$ corresponding to the mapping of the input at any instant of time onto an n -tuple of scalars. Similarly, each output of α_0^{-1} would arise from the effect of a set of inputs $g_1(t), g_2(t), \dots$ that correspond at each instant of time to the representation of the output as an m -tuple of scalars. With this interpretation, the canonic representation of Fig. 6 would

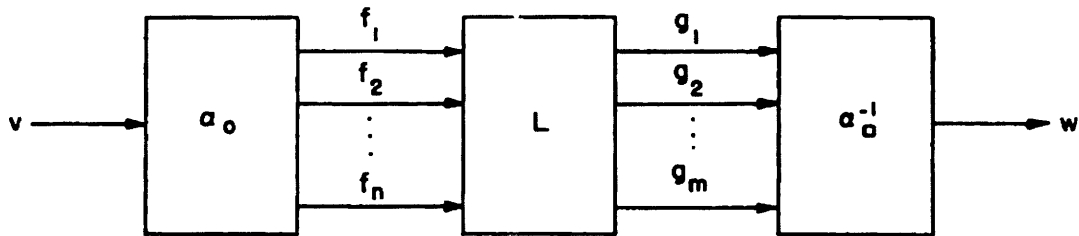

Fig. 8. Canonic representation of a homomorphic system with memoryless input and output operations.

appear in the form of Fig. 8. In this interpretation the system L has n inputs and m outputs. It is linear in the sense that, if g_1, g_2, \dots, g_m are the responses to a set of inputs f_1, f_2, \dots, f_n , and g'_1, g'_2, \dots, g'_m are the responses to a set of inputs f'_1, f'_2, \dots, f'_n , then

$$(g_1 + g'_1), (g_2 + g'_2), \dots, (g_m + g'_m)$$

will be the responses to the inputs

$$(f_1 + f'_1), (f_2 + f'_2), \dots, (f_n + f'_n),$$

and

$$cg_1, cg_2, \dots, cg_m$$

will be the responses to cf_1, cf_2, \dots, cf_n for any scalar c and for any set of inputs.

If an inner product can be defined on the vector space S_t , then the output of α_o at time t can be described as the result of the inner product of v with each of the basis vectors of S_t . Specifically, let the inner product of $v|_t$ and $v_2|_t$ be denoted $(v|_t, v_2|_t)$. Let $\beta_{1t}, \beta_{2t}, \dots$ denote a basis of S_t . Then any scalar value $v|_t$ in S_t can be written

$$v|_t = [(v|_t, \beta_{1t})\beta_{1t}] \circ [(v|_t, \beta_{2t})\beta_{2t}] \circ \dots$$

The n -tuple representing $v|_t$ is, then, (c_1, c_2, \dots, c_n) , where $c_j = (v|_t, \beta_{jt})$. In general, for different values of t , the spaces S_t will differ; hence, both the inner product and the set of basis vectors $\beta_{1t}, \beta_{2t}, \dots$ will be functions of time. Let us denote the operation of taking the inner product of the input at any instant of time t with the j^{th} orthonormal basis vector in S_t by $H_j|_t(v|_t)$, that is,

$$H_j|_t(v|_t) \equiv (v|_t, \beta_{jt}).$$

Then, as we consider all instants of time, we have constructed a function $H_j(v)$ with the property that

$$[H_j(v)]|_t = H_j|_t(v|_t).$$

By referring to the definition of the outputs of α_o , we see, then, that

$$H_j(v) = f_j(t) \quad j = 1, 2, \dots, n.$$

To construct the inverse of H_j , we observe that the inverse of $H_j|_t$ corresponds simply to the combination of $H_j|_t(v|_t)$ with the basis vector β_j according to the operation of scalar multiplication in the vector space V , that is,

$$H_j|_t^{-1}[c] = c \beta_{jt}.$$

Hence, the inverse of H_j is

$$H_j^{-1}[f(t)] = f(t) \beta_j(t),$$

where $\beta_j(t)$ denotes the j^{th} orthonormal basis vector in S_t as a function of t . Interpreting Fig. 8 in the light of this discussion, then, we can replace the systems α_o and α_o^{-1} as shown in Fig. 9.

As an example of the application of these ideas to the construction of the systems α_o and α_o^{-1} , consider a homomorphic system with addition as the input operation and addition as the output operation, that is, a linear system. The operations of vector addition and scalar multiplication on the input vector space are

$$v_1 \circ v_2 = v_1 + v_2,$$

and

$$c \cdot v = cv.$$

Let S_t denote the set of all possible values that the input can assume at time t . We have shown that S_t is a vector space. In particular, it is a one-dimensional vector space.

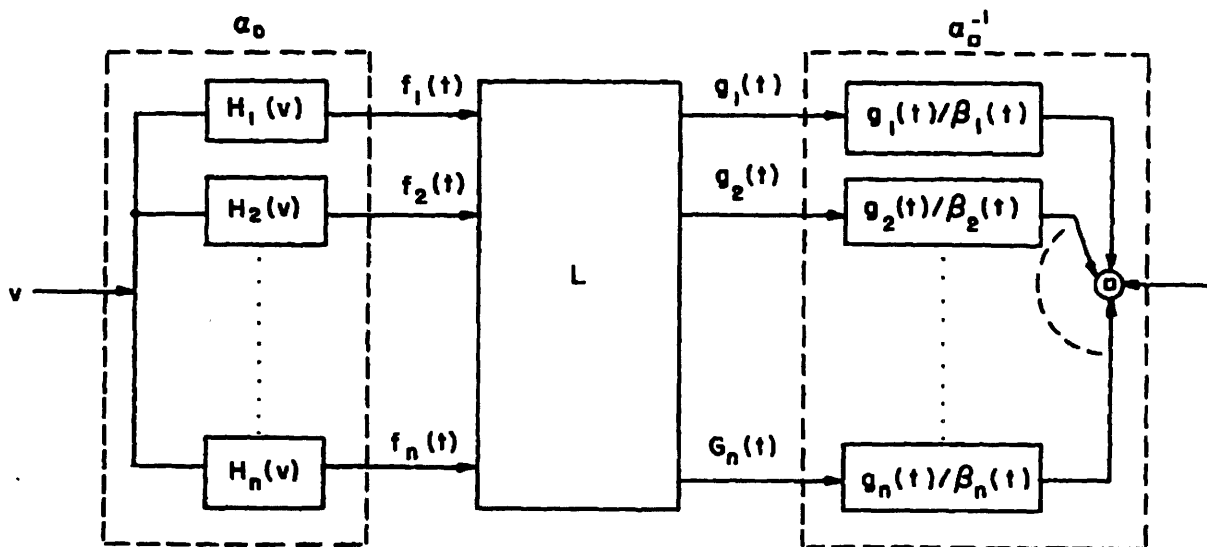

Fig. 9. Canonic representation of a homomorphic system with memoryless input and output operations, illustrating the construction of the characteristic systems.

For, choose any nonzero value β in S_t as a basis vector, then any value η in S_t can be expressed in the form $\eta = c \cdot \beta = c\beta$ for some scalar c in the field. Specifically,

$$c = \frac{1}{\beta}(\eta).$$

where $\frac{1}{\beta}$ is well defined, since it is a nonzero scalar in the field, and hence has an inverse under multiplication. Thus the vector β in S_t spans S_t . Let an inner product be defined in S_t as follows: if η_1 and η_2 are any two vectors in S_t , then the inner product of η_1 and η_2 , denoted by (η_1, η_2) will be defined as

$$(\eta_1, \eta_2) = \eta_1 \bar{\eta}_2.$$

If the field is the field of real numbers rather than the field of complex numbers, then

$$(\eta_1, \eta_2) = \eta_1 \eta_2.$$

To verify that Eq. 47 defines an inner product, we refer to Definition 5. Let $\eta_1, \eta_2,$ and η_3 be any vectors in S_t . Then

$$(1) ((\eta_1 + \eta_2), \eta_3) = (\eta_1 + \eta_2) \bar{\eta}_3$$

and thus

$$((\eta_1 + \eta_2), \eta_3) = (\eta_1, \eta_3) + (\eta_2, \eta_3).$$

$$(2) (c\eta_1, \eta_2) = c\eta_1 \bar{\eta}_2 = c \cdot (\eta_1, \eta_2).$$

$$(3) (\eta_1, \eta_2) = \overline{(\eta_2, \eta_1)}$$

$$(4) (\eta_1, \eta_1) = \eta_1 \bar{\eta}_1 > 0, \quad \eta_1 \neq 0.$$

An orthonormal basis for S_t under this choice for the inner product is the choice $\beta = 1$. We are guaranteed that the scalar 1 is in S_t ; for, if η is any scalar in S_t then $\frac{1}{\eta}$ must be a scalar in the field, and since S_t is a vector space, the scalar

$$\frac{1}{\eta} \eta = 1$$

must be in S_t .

Since S_t is a one-dimensional vector space, the system α_o has a single output. The operation $H|_t(v|_t)$ is given by

$$H|_t(v|_t) = (v|_t, \beta) = v|_t,$$

and hence $H(v) = v$. Consequently, the system α_o is simply the identity system, as would have been expected without recourse to this formalism. By a similar procedure, the system α_\square and hence α_\square^{-1} is the identity transformation.

The choice of inner product specified by Eq. 47 is by no means a unique choice. As the inner product changes, the orthonormal basis also changes. In terms of a different inner product, the systems α_o and α_\square will be different. Consider, for example, the inner product (η_1, η_2) defined as

$$(\eta_1, \eta_2) = k\eta_1 \bar{\eta}_2$$

for some positive real scalar k in the field. It can be verified that this inner product has the properties required of an inner product. Under this inner product, an orthonormal basis for S_t is the vector

$$\beta = k^{-1/2}.$$

The operator $H|_t(v|_t)$ is then given by

$$H|_t(v|_t) = (v|_t, \beta) = k^{1/2} v|_t$$

and hence

$$H(v) = k^{1/2} v.$$

Thus the system α_0 is an amplifier of gain $k^{1/2}$. If this same inner product is associated with the output vector space, then the system α_0^{-1} will be an amplifier of gain $k^{-1/2}$. Alternatively, different inner products can be associated with the input and output vector spaces; the systems α_0 , L and α_0^{-1} will depend in general on the manner in which these inner products are defined.

As another example, consider the class of systems having an input vector space V with vector addition and scalar multiplication defined as

$$v_1 \circ v_2 = v_1 v_2$$

$$c \cdot v_1 = [v_1]^c$$

for all v_1 and v_2 in V and all scalars c in the field. Let the field be restricted to the field of real numbers, and the time functions be restricted to have only positive values. Again, S_t will denote the set of values which the inputs can assume at time t . S_t is a one-dimensional vector space. For, let β be any vector in S_t other than unity, then for any vector η in S_t there exists a scalar c in F such that

$$c \cdot \beta = [\beta]^c = \eta. \tag{48}$$

This follows from the fact that all scalars in S_t must be positive. Hence the natural logarithms of β and η are defined, and the natural logarithm of β is nonzero, since β is not equal to unity. The choice of the scalar c in Eq. 48 is given by

$$c = \frac{\ln(\eta)}{\ln(\beta)}.$$

In the previous example, the system α_0 was constructed by first defining an inner product. Let us instead, in this example, determine α_0 by first constructing the inverse α_0^{-1} . We know that this approach can be used, since there is always some inner product under which the basis for S_t is orthonormal when the dimension of S_t is finite, as it is in this example. Hence we do not need to define an inner product in S_t in order to determine an orthonormal basis for S_t . From the previous discussion we see that the system α_0^{-1} is described by

$$a_0^{-1}(x) = x_{>\beta}$$

where $x = a_0(v)$ for some input v . Since

$$x_{>\beta} = [\beta]^x,$$

we have

$$a_0^{-1}(x) = [\beta]^x.$$

We recognize the inverse of this system as the logarithm to the base β and hence

$$a_0[v] = \log_{\beta} [v].$$

It would be instructive to determine the inner product under which β is orthonormal. To do this, consider the fact that with the above-mentioned choice of a_0 , the operator $H|_t$ is given by

$$H|_t(v|_t) = \log_{\beta} [v|_t].$$

Hence, from the definition of $H|_t$,

$$(v|_t, \beta) = \log_{\beta} [v|_t].$$

Consider the inner product of any two vectors η_1 and η_2 in S_t given by

$$(\eta_1, \eta_2) = [\log_{\beta} (\eta_1)][\log_{\beta} (\eta_2)]. \quad (49)$$

Before showing that β is orthonormal under this inner product, let us first verify that (49) does in fact define an inner product.

$$\begin{aligned} (1) \quad (\eta_1 \eta_2, \eta_3) &= [\log_{\beta} (\eta_1 \eta_2)][\log_{\beta} (\eta_3)] \\ &= [\log_{\beta} \eta_1 + \log_{\beta} \eta_2][\log_{\beta} (\eta_3)] \\ &= (\log_{\beta} \eta_1)(\log_{\beta} \eta_3) + (\log_{\beta} \eta_2)(\log_{\beta} \eta_3) \end{aligned}$$

and thus

$$(\eta_1 \eta_2, \eta_3) = (\eta_1, \eta_3) + (\eta_2, \eta_3).$$

$$(2) \quad (\eta_1^c, \eta_2) = c(\log_{\beta} \eta_1)(\log_{\beta} \eta_2) = c(\eta_1, \eta_2)$$

(3) Property (3) does not have to be verified, since the field has been restricted to the field of real numbers.

$$(4) (\eta_1, \eta_1) = (\log_{\beta} \eta_1)^2 > 0 \quad \text{for } \eta_1 \neq 1 \text{ as required.}$$

It follows directly that the vector β is orthonormal under this inner product for

$$(\beta, \beta) = [\log_{\beta} (\beta)]^2 = 1.$$

4.5 APPLICATION TO NONADDITIVE FEEDBACK SYSTEMS

The notion of homomorphic systems can be used to transform some systems with nonadditive feedback to systems with additive feedback. In certain special cases this transformation has the effect of removing the system nonlinearities. In such cases, stability of the nonlinear feedback system can be investigated by using the techniques available for the study of linear feedback systems.

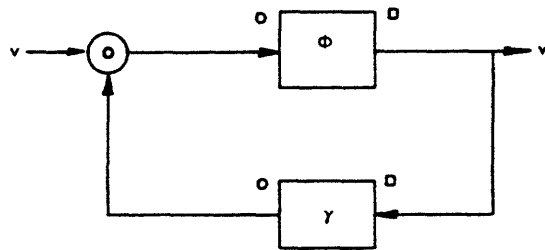

Fig. 10. Homomorphic feedback system with nonadditive feedback.

Consider a feedback system of the form shown in Fig. 10. The inputs are assumed to be a Hilbert space with an orthonormal basis, in which vector addition is the operation \circ . The system ϕ is a homomorphic system with input operation \circ and output operation \circ . The system γ is a homomorphic system with input operation \circ and output operation \circ . The feedback operation is identical to the input operation of ϕ and the output operation of γ .

The first step in the transformation of the system of Fig. 10 is to replace ϕ and γ with their canonic representations. We recognize that since the input operation of ϕ is identical to the output operation of γ , the first system in the canonic representation for ϕ can be chosen as the last system in the canonic representation for γ . Similarly, since the output operation of ϕ is identical to the input operation of γ , the last system in the canonic representation for ϕ is identical to the first system in the canonic representation for γ . When ϕ and γ are replaced by their canonic representations, the system of Fig. 11 results. From Fig. 11 we see that the input x_2 to the linear system L_1 is given by

$$x_2 = a_o \left[v \circ a_o^{-1}(y_2) \right]$$

or, since α_o is a homomorphic system,

$$x_2 = \alpha_o(v) + y_2.$$

The input y_1 to the linear system L_2 is given by

$$y_1 = \alpha_{\square} \left[\alpha_{\square}^{-1}(x_3) \right].$$

Hence, the block diagram of Fig. 11 can be transformed to that shown in Fig. 12. From the block diagram of Fig. 12 we recognize the feedback system as a cascade of α_o , a linear system, and α_{\square}^{-1} . Hence, it is a homomorphic system with o and \square as the input

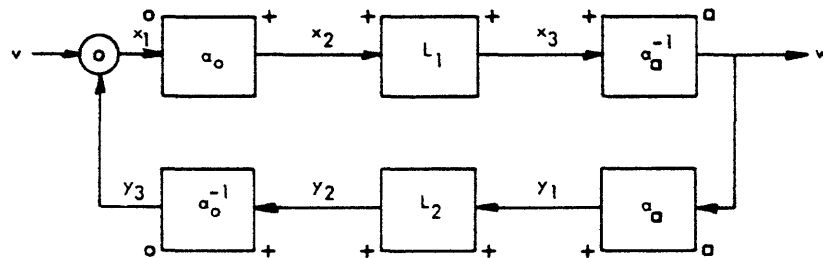

Fig. 11. Equivalent representation of a homomorphic feedback system.

and output operations, respectively. The canonic representation for this homomorphic system is, of course, the block diagram of Fig. 12. The linear portion of the canonic representation is a linear feedback system having the linear portion of ϕ in the forward path and the linear portion of γ in the feedback path.

The systems α_o and α_{\square}^{-1} in the system of Fig. 12 are determined by the classes to

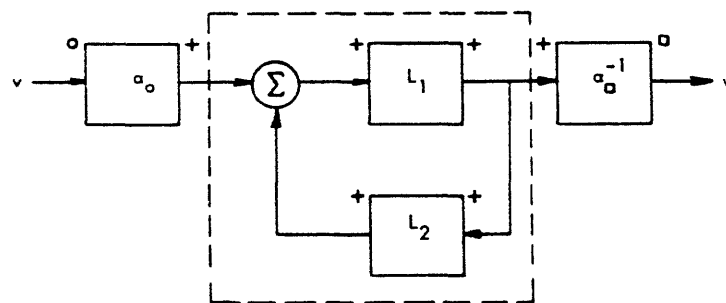

Fig. 12. Canonic representation of a homomorphic feedback system.

which the systems ϕ and γ belong. Hence, as ϕ and γ are varied within their respective classes, the systems α_o and α_{\square}^{-1} remain the same; changes in ϕ and γ are represented by changes in the linear systems L_1 and L_2 . Thus the behavior of the feedback

system of Fig. 10 as the systems ϕ and γ are varied within their respective classes can be studied by concentrating on the behavior of the linear feedback system enclosed in the dotted line in Fig. 12.

The fact that the nonlinearities in the system of Fig. 10 can be removed from the feedback loop depends on the fact that the feedback operation is identical to the input operation of ϕ and the output operation of γ , and that the output operation of ϕ and the input operation of γ are identical. Under these restrictions, and the restriction that the system inputs constitute a vector space under \circ , the system outputs will constitute a vector space under \circ . It can also be verified that the set of inputs to ϕ is a vector space under \circ and the set of outputs of γ is a vector space under \circ .

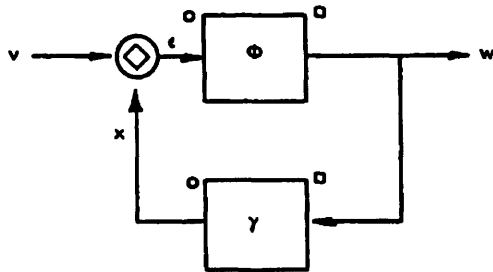

Fig. 13. Nonadditive feedback system with homomorphic systems in the forward and feedback paths.

If we do not impose the restriction that the feedback operation be identical to the input operation of ϕ and the output operation of γ , we can still, in certain cases, transform the system to a feedback system with additive feedback. The over-all system will no longer be a homomorphic system; consequently, the feedback loop will remain nonlinear.

Specifically, consider the feedback system in Fig. 13. The system inputs constitute part of a Hilbert space under the operation \circ . It is assumed that the system of Fig. 13 is well defined, that is, the operation \circ is defined on all inputs to ϕ and the operation \circ is defined on all the outputs of γ . This would be true, for example, if ϕ and γ were both linear systems and the operation were multiplication.

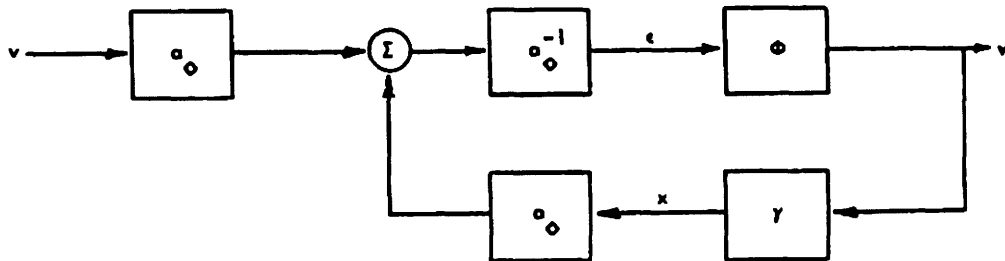

Fig. 14. Equivalent representation of the feedback system of Fig. 13.

Since the system inputs constitute a vector space under the operation \circ , there exists an invertible homomorphic system a_\circ , having \circ as the input operation and addition as the output operation.

The input ϵ to ϕ is given by

$$\epsilon = v \diamond x$$

or, equivalently,

$$\epsilon = a_{\diamond}^{-1}[a_{\diamond}(v \diamond x)].$$

Since a_{\diamond} is a homomorphic system, (50) can be rewritten

$$\epsilon = a_{\diamond}^{-1}[a_{\diamond}(v) + a_{\diamond}(x)].$$

Consequently, the system of Fig. 13 can be redrawn as shown in Fig. 14. When the canonic representations for ϕ and γ are substituted in the block diagram of Fig. 14, and appropriate block diagram manipulations are performed, the system of Fig. 14 can

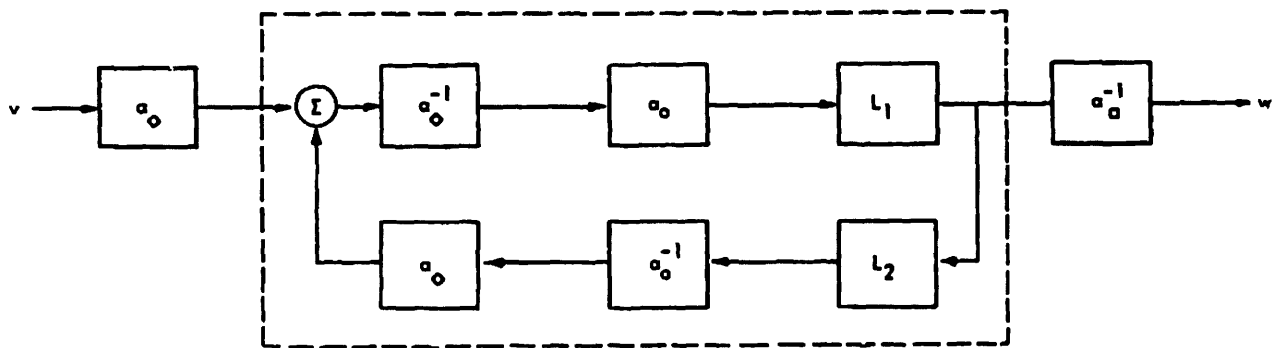

Fig. 15. Equivalent representation of the feedback system of Fig. 13.

be transformed to that shown in Fig. 15. If the system γ is an invertible system, then the system L_2 will also be invertible. In this case, the system for Fig. 15 can be transformed to that shown in Fig. 16, for which

$$a = a_{\diamond} a_{\diamond}^{-1}$$

$$L = L_1 L_2^{-1}$$

$$\beta = a_{\diamond}^{-1} L_2^{-1} a_{\diamond} a_{\diamond}^{-1}.$$

If this feedback system is to be studied as the system ϕ is varied within its class, then, the systems a and β will remain invariant with changes in ϕ . Hence, properties of the feedback system of Fig. 13, as ϕ is varied within any one class, can be studied by

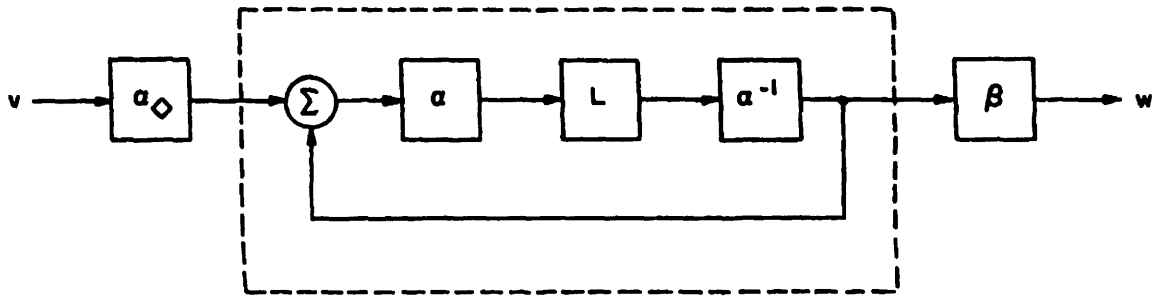

Fig. 16. Equivalent representation of the feedback system of Fig. 13 for the case in which γ is invertible.

concentrating on the feedback system enclosed in the dotted line in Fig. 16. Although this feedback system is nonlinear, it is characterized by the property that it is a unity feedback system in which the forward path contains a linear system inserted between a nonlinear system and its inverse.

APPENDIX

Isomorphic Mapping of a Separable Hilbert Space into the Space F^n

In Section IV, we were concerned with the construction of an isomorphic mapping from the input and output spaces of a homomorphic system into spaces under addition. The input and output spaces were restricted to be separable Hilbert spaces, i.e., Hilbert spaces having orthonormal bases. When the operations of vector addition and scalar multiplication were memoryless operations, the set of values which the associated time functions could assume at any instant of time was shown to constitute a vector space. It was then stated that an isomorphism could be defined which mapped the set of values at any instant of time onto the space F^n . The purpose of this appendix is to carry out the derivation of these results.

Consider a separable Hilbert space in which the orthonormal basis is denoted $f_1(t)$, $f_2(t)$, Then if $f(t)$ is any function in the space, $f(t)$ can be expressed in the form

$$f(t) = \sum_0^{\infty} [(f(t), f_k(t))_{>} f_k(t)], \quad (\text{A. 1})$$

where \sum_0 denotes the combination of the functions $[(f(t), f_k(t))_{>} f_k(t)]$ according to the operation o . Let S denote the set of all values that can be assumed by the functions in the space at any given time t_0 . If o and $>$ are memoryless operations, then, from Eq. A. 1,

$$f(t_0) = \sum_0^{\infty} [(f(t), f_k(t))_{>} f_k(t_0)].$$

Consequently, for any scalar $f(t_0)$ in S there exists a set of scalars $\lambda_1, \lambda_2, \dots$ such that

$$f(t_0) = \sum_0^{\infty} \lambda_k > f_k(t_0).$$

The scalar λ_k is given by

$$\lambda_k = (f(t), f_k(t)).$$

The vector space S is spanned by the scalars $f_1(t_0), f_2(t_0), \dots$ in the sense that any scalar in S is the limit of a linear combination of the scalars $f_1(t_0), f_2(t_0), \dots$ under the operations o and $>$. The set of scalars $f_1(t_0), f_2(t_0), \dots$ is a countable set, since an orthonormal basis for a separable Hilbert space is countable. This set of scalars may or may not constitute a basis for S , that is, they may or may not be independent. They contain, however, an independent set in terms of which any scalar in S can be

expressed as a (possibly infinite) linear combination, as the following argument shows.

If the set S contains only one scalar, then this scalar must be the identity in S because S is a vector space. Since $f_1(t_0), f_2(t_0), \dots$ are each in S , they must all be equal to the identity in S . In this case, any one of these scalars is a basis for S , and hence the proof is complete.

If the set S contains more than one scalar, then the set $f_1(t_0), f_2(t_0), \dots$ must contain at least one scalar that is not the identity in S . Let s_1, s_2, \dots denote the sequence of all scalars from the sequence $f_1(t_0), f_2(t_0), \dots$ which are other than the identity in S . This sequence is nonempty by virtue of the comments just made. Let S_1 be the subspace of scalars s in S which is spanned by s_1 . Let s'_2 be the first scalar in the sequence s_1, s_2, \dots which is not in S_1 , and let S_2 denote the subspace of S spanned by s'_1 and s'_2 , where $s'_1 \equiv s_1$. Continuing this process, we obtain a sequence of subspaces S_1, S_2, \dots of S . Since S is the limit of the sequence of partial sums $\sum_{k=1}^n [(f(t), f_k(t)) > f_k(t_0)]$, the limit of the sequence of subspaces S_1, S_2, \dots is S . Hence the sequence s'_1, s'_2, \dots spans S , since the space S_n can be expressed as a combination of s'_1, s'_2, \dots, s'_n under the operations \circ and $>$. Furthermore, by the manner in which the sequence s'_1, s'_2, \dots was generated, it is independent. This sequence forms a basis for the space S in the sense that it is independent and that any element in S can be expressed as the limit of partial sums of scalars in the sequence.

We wish to show next that S is isomorphic with F^n for some n . Let s be any scalar in S . Since the sequence s'_1, s'_2, \dots spans S and since this sequence is independent, s can be expressed in one and only one way in the form

$$s = \sum_{\circ, 1}^n c_k > s'_k$$

for a set of scalars $\{c_k\}$ from F , where $c_k = [(f(t) > f_k(t))]$. The isomorphism T from S to F^n is then defined as

$$T(s) = (c_1, c_2, \dots).$$

Acknowledgment

The study of Modern Algebra and the possibilities of its application to the treatment of nonlinear systems was first suggested to me by Dr. Manuel V. Cerrillo of the Research Laboratory of Electronics, M.I.T. I am grateful to Dr. Cerrillo for both this suggestion and for many stimulating discussions during my introduction to research.

Before and during the development of the thesis I was fortunate to have the benefit of a close association with Professor Amar G. Bose and Professor Henry J. Zimmermann. I am grateful for their contributions to my thesis research and to my personal development. I thank Professor Trenchard More, Jr., and Professor Thomas G. Stockham, Jr., who assisted in the supervision of the thesis. Their discussions and suggestions with regard to both details and philosophy have had a major effect in shaping the final work. I would also like to express my appreciation to Mr. Thomas G. Kincaid of the Department of Electrical Engineering, M. I. T. Our long and stimulating discussions during the early phases of the research contributed significantly to the results presented in this work. Finally, I express my gratitude for the support of this work by the Research Laboratory of Electronics, M. I. T.

References

1. V. Volterra, Theory of Functionals and Integro-differential Equations, (Dover Publications, Inc., New York, 1959).
2. N. Wiener, Nonlinear Problems in Random Theory (The Technology Press of Massachusetts Institute of Technology, Cambridge, Mass., and John Wiley and Sons, Inc., New York, 1958).
3. R. H. Cameron and W. T. Martin, The orthogonal development of nonlinear functionals in series of Fourier-Hermite functionals, Ann. Math. 48, 385-389 (1947).
4. A. G. Bose, A Theory of Nonlinear Systems, Technical Report 309, Research Laboratory of Electronics, M. I. T., Cambridge, Mass., May 15, 1956.
5. S. K. Berberian, Introduction to Hilbert Space (Oxford University Press, New York, 1961).
6. K. Hoffman and R. Kunze, Linear Algebra (Prentice-Hall, Inc., Englewood Cliffs, New Jersey, 1961).
7. A. E. Taylor, Introduction to Functional Analysis (John Wiley and Sons, Inc., New York, 1958).
8. S. K. Berberian, op. cit., Theorem IV. 7. 3.
9. Ibid., Theorems III. 4. 1 and III. 5. 1; see especially example 5. 1.
10. Ibid., Theorem II. 5. 1.



JOINT SERVICES DISTRIBUTION LIST

Department of Defense

Dr Edward M. Reilley
Asst Director (Research)
Ofc of Defense Res & Eng
Department of Defense
Washington, D.C. 20301

Dr James A. Ward
Office of Deputy Director (Research
and Information Rm 3D1037
Department of Defense
The Pentagon
Washington, D.C. 20301

Director
Advanced Research Projects Agency
Department of Defense
Washington, D.C. 20301

Mr Charles Yost, Director
For Materials Sciences
Advanced Research Projects Agency
Department of Defense
Washington, D.C. 20301

Defense Documentation Center
Attn: TISIA
Cameron Station, Bldg 5
Alexandria, Virginia 22314

Director
National Security Agency
Attn: C3/TDL
Fort George G. Meade, Maryland 20755

Department of the Army

Chief of Research and Development
Headquarters, Department of the Army
Attn: Physical Sciences Division P&E
Washington, D.C. 20310

Research Plans Office
U. S. Army Research Office
3045 Columbia Pike
Arlington, Virginia 22204

Commanding Officer
Foreign Service & Technology Center
Arlington Hall
Arlington, Virginia

Commanding General
U. S. Army Materiel Command
Attn: AMCRD-RS-PE-E
Washington, D.C. 20315

Commanding General
U. S. Army Strategic Communications
Command
Washington, D.C. 20315

Commanding General
U. S. Army Materials Research Agency
Watertown Arsenal
Watertown, Massachusetts 02172

Commanding Officer
U. S. Army Ballistics Research Laboratory
Attn: V.W. Richards
Aberdeen Proving Ground
Aberdeen, Maryland 21005

Commandant
U. S. Army Air Defense School
Attn: Missile Sciences Division, C&S Dept.
P.O. Box 9390
Fort Bliss, Texas 79916

Commanding General
U. S. Army Missile Command
Attn: Technical Library
Redstone Arsenal, Alabama 35809

Commanding General
Frankford Arsenal
Attn: SMUFA-1310 (Dr Sidney Ross)
Philadelphia, Pennsylvania 19137

U. S. Army Munitions Command
Attn: Technical Information Branch
Picatinney Arsenal
Dover, New Jersey 07801

Commanding Officer
Harry Diamond Laboratories
Attn: Mr Berthold Altman
Connecticut Avenue and Van Ness Street N. W.
Washington, D.C. 20438

Commanding Officer
Harry Diamond Laboratories
Attn: Dr R. T. Young
Electron Tubes Division
Connecticut Avenue and Van Ness Street N. W.
Washington, D.C. 20438

Commanding Officer
U. S. Army Security Agency
Arlington Hall
Arlington, Virginia 22212

Commanding Officer
U. S. Limited War Laboratory
Attn: Technical Director
Aberdeen Proving Ground
Aberdeen, Maryland 21005

JOINT SERVICES DISTRIBUTION LIST (continued)

Commanding Officer
Human Engineering Laboratories
Aberdeen Proving Ground
Maryland 21005

Director
U. S. Army Engineer Geodesy,
Intelligence and Mapping
Research and Development Agency
Fort Belvoir, Virginia 22060

Commandant
U. S. Army Command and General Staff
College
Attn: Secretary
Fort Leavenworth, Kansas 66207

Dr. H. Robl, Deputy Director
U. S. Army Research Office (Durham)
P. O. Box CM, Duke Station
Durham, North Carolina 27706

Commanding Officer
U. S. Army Research Office (Durham)
Attn: CRD-AA-IP (Richard O. Ulsh)
P. O. Box CM, Duke Station
Durham, North Carolina 27706

Commanding General
U. S. Army Electronics Command
Attn: AMSEL-SC
Fort Monmouth, New Jersey 07703

Director
U. S. Army Electronics Laboratories
Attn: Dr S. Benedict Levin, Director
Institute for Exploratory Research
Fort Monmouth, New Jersey 07703

Director
U. S. Army Electronics Laboratories
Attn: Mr Robert O. Parker, Executive
Secretary JSTAC (AMSEL-RD-X)
Fort Monmouth, New Jersey 07703

Superintendent
U. S. Army Military Academy
West Point, New York 10996

The Walter Reed Institute of Research
Walter Reed Army Medical Center
Washington, D. C. 20012

Director
U. S. Army Electronics Laboratories
Fort Monmouth, New Jersey 07703

Attn: AMSEL-RD-DR NE SS
 X NO PE
 XE NP PR
 XC SA PF
 XS SE GF
 NR SR ADT
 FU#1

Commanding Officer
U. S. Army Electronics R&D Activity
Fort Huachuca, Arizona 85163

Commanding Officer
U. S. Army Engineers R&D Laboratory
Attn: STINFO Branch
Fort Belvoir, Virginia 22060

Commanding Officer
U. S. Army Electronics R&D Activity
White Sands Missile Range
New Mexico 88002

Director
Human Resources Research Office
The George Washington University
300 N. Washington Street
Alexandria, Virginia 22314

Commanding Officer
U. S. Army Personnel Research Office
Washington, D. C.

Commanding Officer
U. S. Army Medical Research Laboratory
Fort Knox, Kentucky

Department of the Air Force

Director
Air University Library
Maxwell A. F. Base, Alabama

Commander
Air Force Office of Scientific Research
Washington 25, D. C.
Attn:-SREE

Department of The Air Force
Headquarters-United States Air Force
Washington 25, D. C.
Attn: AFTAC/TD-1

Dr. Harvey E. Savely, SRL
Air Force Office of Sci. Res.
Office of Aerospace Research, USAF
Washington 25, D. C.

Mr. C. N. Hasert
Scientific Advisory Board
Hq, USAF
Washington 25, D. C.

JOINT SERVICES DISTRIBUTION LIST (continued)

APGC (PGBAP-1)
Elgin Air Force Base
Florida 32542

AFETR
(AFETR Tech. Library MU-135)
Patrick Air Force Base
Cocoa, Florida

Air Force Cambridge Res. Lab.
L.G. Hanscom Field
Bedford, Massachusetts 01731
Attn: CRDM, Mr. Herskovitz

Commander, AFCRL
Attn: C. P. Smith (CRBS)
L.G. Hanscom Field
Bedford, Massachusetts

Dr. L. C. Block
AFCRL (CROV)
L. G. Hanscom Field
Bedford, Massachusetts

AFCRL
Office of Aerospace Res., USAF
Bedford, Mass.
Attn: CRDA

Mr. Rocco H. Urbano, Chief
AFCRL, Appl. Math. Branch
Data Sciences Laboratory
Laurence G. Hanscom Field
Bedford, Massachusetts

AFCRL (CRFE-Dr. Nicholas Yannoni)
L.G. Hanscom Field
Bedford, Massachusetts

S. H. Sternick
Aerospace Comm. - Attn: ESNC
Waltham Federal Center
424 Trapelo Road
Waltham, Massachusetts 02154

Rome Air Dev. Center (RAWL, H. Webb)
Griffiss Air Force Base
New York 13442

Systems Engineering Group
Deputy for Systems Eng'g., SEPRR
Directorate of Tech. Pubs. and Specs.
Wright-Patterson AFB, OHIO 45433

Aeronautical Systems Division
Attn: ASRPE, Mr. Robt. Cooper
Wright-Patterson AFC, Ohio 45433

Aeronautical Systems Division
Attn: ASRPP-20 (Mr. Don R. Warnock)
Wright-Patterson AFB, Ohio 45433

AFAL
AVR (L)
Wright-Patterson AFB
Ohio 45433

Dr. H. H. Kurzweg
Director Research - OART
NASA
Washington, D. C. 20546

Systems Engineering Group (RTD)
Attn: SEPIR
Wright-Patterson AFB, Ohio 45433

AFAL (AVTE)
Wright-Patterson AFB
Ohio 45433

Mr. Roland Chase
National Aeronautics & Space Administration
1512 H Street, N.W.
Washington 25, D. C.

Professor Arwin Dougal
University of Texas
EE Department
Austin, Texas

Honorable Alexander H. Flax
Asst Secretary of the Air Force (R&D)
Office of the Secretary of the Air Force
Washington 25, D. C.

Professor Nicholas George
California Institute of Technology
EE Department
Pasadena, California

Dr. Lowell M. Hollingsworth
AFCRL
L.G. Hanscom Field
Bedford, Massachusetts

Dr. Zohrab Kaprielian
University of Southern California
University Park
Los Angeles 7, California

JOINT SERVICES DISTRIBUTION LIST (continued)

Dr. John M. Ide
National Science Foundation
Washington 25, D. C.

Lt Col Edwin M. Myers
Headquarters USAF (AFRDR)
Washington 25, D. C.

Professor Wm. H. Radford
Director, Lincoln Laboratories
Lexington, Massachusetts

Brig Gen B.G. Holzman, USAF (Ret.)
Electronics Research Center, NASA
30 Memorial Drive
Cambridge, Mass.

Dr. R. L. Sproull
Director, Advanced Research Projects
Agency
Washington 25, D. C.

Brigadier General J. T. Stewart
Director of Science & Technology
Deputy Chief of Staff (R&D)
USAF
Washington 25, D. C.

Mr. James Tippet
National Security Agency
Fort Meade, Maryland

Dr. H. Harrison
NASA (Code RRE)
Fourth and Independence Streets
Washington, D. C. 20546

AEC
Civ of Tech Info Ext
P. O. Box 62
Oak Ridge, Tenn.

AFRST (SC/EN)
Lt Col L. Stone
Rm 4C 341
The Pentagon
Washington, D. C. 20301

U. S. Atomic Energy Commission
Library
Gaithersburg, Md. 20760

ARL (ARD/Col R. E. Fontana)
Wright-Patterson AFB,
Ohio 45433

Office of Research Analyses
Attn: Col K. W. Gallup
Holloman AFB, NMex 88330

AFCLRL (CRXL)
L. G. Hanscom Fld
Bedford, Mass 01731

Frank J. Seiler Resch Lab
Library
USAF Academy, Colo 80840

ARL (AROL)
Wright-Patterson AFB,
Ohio 45433

Office of Research Analyses
Library
Holloman AFB, NMex 88330

LOOAR (Library)
AF Unit Post Office
Los Angeles, Calif 90045

Churchill Research Range
Library
Fort Churchill
Manitoba, Canada

Los Alamos Scientific Lab
Attn: Technical Library
Los Alamos, NMex 87544

Battelle Memorial Institute
Technical Library
505 King Avenue
Columbus, Ohio 43201

John Crerar Library
35 West 33rd St.
Chicago, Ill.

Linda Hall Library
5109 Cherry St.
Kansas City, Mo.

National Science Foundation
Library
1951 Constitution Ave., N. W.
Washington, D. C. 20550

JOINT SERVICES DISTRIBUTION LIST (continued)

Johns Hopkins University
Applied Physics Lab Library
White Oak
Silver Spring, Md. 20910

Stanford Research Institute
Library
820 Mission St.
South Pasadena, Calif. 91030

Southwest Research Institute
Library
8500 Culebra Road
San Antonio, Texas

ARPA, Tech Info Office
The Pentagon
Washington, D.C. 20301

DDR&E (Tech Library)
Rm 3C 128
The Pentagon
Washington, D.C. 20301

Industrial College of the
Armed Forces
Attn: Library
Washington, D.C.

AFIT (MCLI)
Tech Library
Wright-Patterson AFB
Ohio 45433

AUL 3T-9663
Maxwell AFB, Ala 36112

USAFA (DLIB)
USAF Academy, Colorado 80840

AFSC (Tech Library)
Andrews AFB
Washington, D.C. 20331

ASD (Tech Library)
Wright-Patterson, AFB
Ohio 45433

BSD (Tech Library)
Norton AFB, Calif 92409

ESD (ESTI)
L. G. Hanscom Field, F172
Bedford, Mass 01731

RTD (Tech Library)
Bolling AFB, D.C. 20332

AFFTC (Tech Library)
Edwards AFB, Calif 93523

AFMDC (Tech Library)
Holloman AFB, NMex 88330

AFWL (WLIL, Tech Library)
Kirtland AFB, NMex 87117

APGC (Tech Library)
Eglin AFB, Fla 32542

AEDC (Tech Library)
Arnold AFS, Tenn 37389

RADC (Tech Library)
Griffiss AFB, N.Y. 13442

Director
National Aeronautical Establishment
Ottawa, Ontario, Canada

CIA
OCR/LY/IAS
IH 129 Hq
Washington, D.C. 20505

National Defense Library
Headquarters
Ottawa, Ontario, Canada

Technical Library
White Sands Missile Range
NMex 88002

NASA/AFSS/1 FOB6
Tech Library, Rm 60084
Washington, D.C. 20546

Space Systems Division
Los Angeles Air Force Station
Air Force Unit Post Office
Los Angeles, California 90045
Attn: SSSD

U.S. Regional Science Office/LAOAR
U.S. Embassy
APO 676
New York, N.Y.

Ames Resch Center (NASA)
Technical Library
Moffett Field, Calif 94035

JOINT SERVICES DISTRIBUTION LIST (continued)

High Speed Flight Center (NASA)
Technical Library
Edwards AFB, Calif 93523

Goddard Space Flight Center (NASA)
Greenbelt, Md. 20771

Geo. C. Marshall Space Flight
Center (NASA)
Redstone Arsenal, Ala 35808

Lewis Research Center (NASA)
Technical Library
21000 Brookpark Road
Cleveland, Ohio

Aerospace Corp (Tech Library)
P.O. Box 95085
Los Angeles, Calif 90045

Rand Corporation
1700 Main St.
Santa Monica, Calif 90401

Carnegie Institute of Technology
Science & Engineering Hunt Library
Schenley Park
Pittsburgh, Pa. 15213

California Institute of Technology
Aeronautics Library
1201 East Calif St.
Pasadena 4, Calif

AVCO Research Lab
Library
2385 Revere Beach Parkway
Everett, Mass 02149

Dr. G. E. Knausenberger
c/o Hq. Co. Munich Post
APO 09407
New York, N. Y.

Commander
Space Systems Division (AFSC)
Office of the Scientific Director
Inglewood, California

Commander
Aerospace Systems Division
AFSC
Office of the Scientific Director
Wright-Patterson AFB, Ohio

Commander
Aerospace Research Laboratories (OAR)
Office of the Scientific Director
Wright-Patterson AFB, Ohio

Commander
Air Force Cambridge Research Laboratories
Office of the Scientific Director
L. G. Hanscom Field
Bedford, Massachusetts

Commander
Air Force Systems Command
Office of the Chief Scientist
Andrews AFB, Maryland

Commander
Research & Technology Division
AFSC
Office of the Scientific Director
Bolling AFB 25, D.C.

Commander
Rome Air Development Center
AFSC
Office of the Scientific Director
Griffiss AFB, Rome, New York

Department of the Navy

Dr. Arnold Shostak, Code 427
Head, Electronics Branch
Physical Sciences Division
Department of the Navy
Office of Naval Research
Washington, D.C. 20360

Chief of Naval Research, Code 427
Department of the Navy
Washington, D.C. 20360

Chief, Bureau of Weapons
Department of the Navy
Washington, D.C. 20360

Chief, Bureau of Ships
Department of the Navy
Washington, D.C. 20360
Attn: Code 680

Commander
U.S. Naval Air Development Center
Johnsville, Pennsylvania
Attn: NADC Library

JOINT SERVICES DISTRIBUTION LIST (continued)

**Library
U. S. Navy Electronics Laboratory
San Diego, California 92152**

**Commanding Officer
U. S. Navy Underwater Sound Laboratory
Ft Trumbull
New London, Connecticut**

**Director
Naval Research Laboratory
Washington, D. C. 20390**

**Commanding Officer
Office of Naval Research Branch Office
Navy 100, Fleet P.O. Box 39
New York, New York**

**Chief of Naval Operations
Pentagon OP 07T
Washington, D. C.**

**Commanding Officer
Officer of Naval Research Branch Office
495 Summer Street
Boston, Massachusetts 02110**

**Commander
Naval Ordnance Laboratory
White Oak, Maryland
Attn: Technical Library**

**U. S. Navy Post Graduate School
Monterey, California
Attn: Electrical Engineering Department**

