

Massachusetts Institute of Technology
Department of Electrical Engineering and Computer Science
6.061/6.979 Introduction to Power Systems

Problem Set 9

Issued April 14, 2003
Due April 23, 2003

Problem 1: This problem deals with a salient pole machine with the following characteristics:

Number of Poles	p	4
Frequency	f	60 Hz
Peak Field to Armature Mutual Inductance	M	300 mHy
Direct Axis Stator Inductance	L_d	11 mHy
Quadrature Axis Stator Inductance	L_q	8 mHy
Rated (Line-Line, RMS) Terminal Voltage	V_B	13,800 V
Machine Rating	P_B	100 MVA

1. Ignoring effects of saturation, what is the no-load field current for this machine (AFNL)?
2. Find the required field current for operation of this machine as a generator at its volt-ampere rating and at 80% power factor, over-excited.
3. Now we are to operate this machine as a synchronous condenser, which is simply a synchronous machine with its shaft unloaded. How much field current is required to reach the full VA capability of the armature, at zero real power over-excited?
4. In under-excited operation we find that we can actually go to some value of *negative* field current (what does this mean?). Find that value of field current. What is the full range of VARs that can be absorbed and/or supplied by this machine? (Hint: consider stability)

Problem 2: Suppose we have a machine with the same stator as the machine you considered in Problem Set 8, but with a rotor wound with a winding just like the stator. It might have characteristics as shown here:

Number of Poles	p	4
Armature Phase Self Inductance	L_a	8.2 mHy
Armature Phase-to-Phase Mutual Inductance	L_{ab}	-4.0 mHy
Rotor Phase Self Inductance	L_A	8.2 mHy
Rotor Phase-to-Phase Mutual Inductance	L_{AB}	-4.0 mHy
Rotor to Stator (Peak) Mutual Inductance	L_{aA}	8.0 mHy
Rotational Speed		1800 RPM
Terminal Voltage (RMS, Line-Line)	V_a	480 v
Rated Power		100 kVA
Frequency		60 Hz

The rotor windings are connected to a set of slip rings and so can be driven. Machines such as these are used for adjustable speed drives and as windmill generators.

Now: suppose this machine is operating as a generator at some speed other than synchronous. The stator is supplying rated volt-amperes at a power factor of 0.8 (so that the stator is supplying VARs). What is the complex power required into the rotor terminals if the machine speed is:

1. 75% of synchronous?
2. 125% of synchronous?

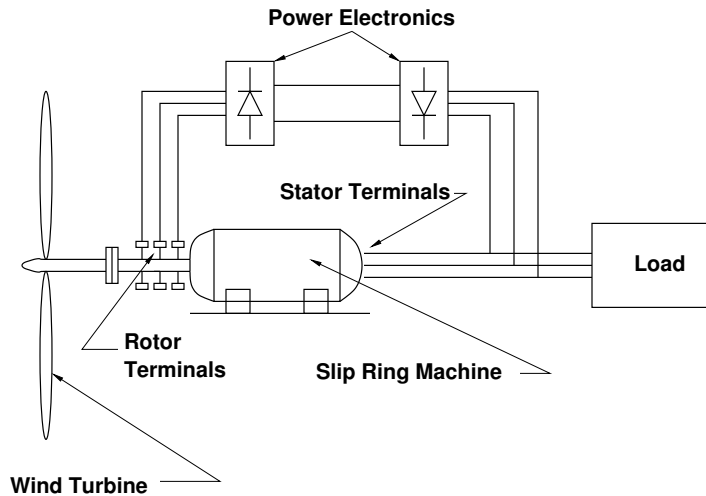

Figure 1: Wind Turbine Generator Setup

Problem 3: for 6.979 The type of machine contemplated in Problem 2 is often used as the generator in wind turbine generation schemes, as shown in Figure 1. Here the slip rings are fed through a bidirectional converter which can provide both real and reactive power to the rotor windings. Assume that the power electronics interacts with the machine (and power bus) terminals at unity power factor (that is, the reactive power either drawn or supplied by the right-hand end of the converter is zero).

Assume that the load is drawing $P=50$ kW, $Q=30$ kVAR. Ignoring losses in the system, find and plot the following quantities over a speed range of between 75% and 125% of synchronous:

1. Power *out of* the stator winding
2. Power *in to* the slip rings (and rotor winding)
3. Power delivered by the wind turbine