

Social Congestion in Shanghai

An Urban Housing Project Designed on Its Sections

by

Wenjun Ge

Bachelor of Architecture, Southeast University, China, 2005

Submitted to the Department of Architecture
in Partial Fulfillment of the Requirement of the Degree of
Master of Science in Architectural Studies
at the
Massachusetts Institute of Technology
August 2008

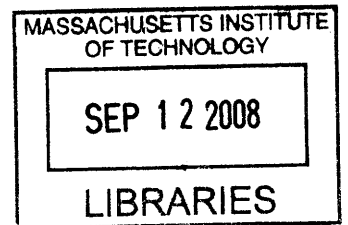

©2008 Wenjun Ge. All rights reserved.

The author hereby granted to MIT permission to reproduce
and to distribute publicly paper and electronic
copies of this thesis document in whole or in part
in any medium now known or hereafter created.

ARCHIVES

Signature of Author:

Aug 8, 2008
Department of Architecture
August 8, 2008

Certified by:

Stanford Anderson
Professor of History and Architecture
Thesis Co-Advisor

Certified by:

Yung Ho Chang
Professor of Architecture
Thesis Co-Advisor

Accepted by:

Julian Beinart
Professor of Architecture
Chair of the Department Committee on Graduate Students

Social Congestion in Shanghai

An Urban Housing Project Designed on Its Sections

by

Wenjun Ge

Submitted to the Department of Architecture

on August 8, 2008

in Partial Fulfillment of the Requirement of the Degree of
Master of Science in Architectural Studies

Abstract

The new housing developments of Shanghai rely on high-rise building, demolishing the prevailing low-rise high-density housing, known as Lilong housing, built in the early 20th century, and known as Lilong housing. The high-rise building, a symbol of modern living providing open view, better sanitation facilities, and higher building density, is usually considered to be a positive architectural revolution. The Lilong housing, despite its tranquil appearance sustained over a century, also experienced a revolution, caused by densification resulting from population explosion and poor maintenance of the buildings. Living in extremely tight space, often less than 6 square meters per person, Lilong residents had to find flexible ways of living by modifying and using space in creative ways. The residents built subtle social connections through the intense contacts of their shared lives. People who have moved from Lilong to high-rise when asked to compare their changed lifestyle, usually appreciate the good privacy, generous space, and full facilities in high-rise housing. However, most of them also dislike being isolated and lament their loss of the “big warm family” of old Lilong (Hammond, 2006, p.41). Believing that a good design should bring people together I am searching for an alternative way to develop hyper-dense urban housing to support communal culture while also actively responding to various modern trends.

Thesis co-advisor: Stanford Anderson

Title: Professor of History and Architecture

Thesis co-advisor: Yung Ho Chang

Title: Professor of Architecture

Content

1. Introduction	7
2. Courtyard housing, a family-centred living system, developed in rural society	14
3. Lilong housing, a community-centred living system, formed at the beginning of urbanization and industrialization	17
4. Work unit, a compact living system, built in an economically difficult period	31
5. Private development residential housing block, after the economic reform	37
6. Conclusion of the housing transformation study.....	42
7. Proposal for a compact neighborhood that brings people together ...	45
8. Conclusion	53
Appendix: Two urban projects as precedents for the concept of compact neighborhood	55
Bibliography	61

1. Introduction:



Figure 1.1 Enjoy the cool breeze in a summer dusk in Lilong neighborhood.



Figure 1.2 A sink in shared kitchen suggests the crowded living in Lilong housing

Lilong housing, an urban living icon of Shanghai famous for its dynamic communal life, dates from the late 19th century. Addressing the high-end housing market, Lilong were built by foreign businessmen as commercial developments (Zhao, 2004, p.13). With rapid growth of the housing market for over a century, original single-family units were broken up to be rented to several households, resulting in a population density in Lilong today multiplies five times the original. In public eyes, Lilong housing, on the bright side, represents the unique dwelling culture of Shanghai (Figure 1.1), while on the dark side, it suggests crowded living lacking in basic privacy and sanitation facilities (Figure 1.2).

Although the Lilong is famous for its dynamic communal life, on the housing market this housing typology is losing its vital energies for many reasons. The most important reason is the limit of density. With Lilong housing, composed of rows

of low-rise bar buildings, it is difficult to reach a FAR greater than 1.8 under the strict sunlight regulation for housing in Shanghai. In the most crowded Lilong neighbourhoods, the population density is as high as 2200 people per hectare. In a new housing development, each person will be allocated approximately 15 square meters, the average living area per person in Shanghai (Lu, Rowe, and Zhang, 2001, p.31). Hence, one can calculate that a new residential development should reach a FAR as high as 3.3 to accommodate the same number of people. Therefore, the limit of the building density of the bar building neighbourhood suggests the fate of Lilong housing – being replaced by high-rise housing. Today in Shanghai, the maintenance of Lilong housing basically has two reasons: 1) some neighbourhoods that are built and preserved well, or have significant historical value, will be preserved by the government; 2) others have not been redeveloped because the cost to compensate current dwellers is too high to pay.

The high cost of the land as well as high population density force housing developers to choose high-rise building as the optimal way for pursuing profit. However the high-rise housing does change urban morphology greatly and create many social problems. In a high-rise building, units are arranged outwards each floor, apart from open space on ground floors. Circulation in open space on ground floors. Circulation in spacious open space is simplified and only occupies a small part of open space; the rest of land is vast and left as recreational space. Each space in high-rise housing is given a specific program, independent from others. The clearly defined space in high-rise housing, compared with lanes in Lilong, does not encourage encounters between people on which social activities are based (Gehl, 1987, p.11).



Figure 1.3 Distinct urban environment formed by high-rise and Lilong housing

The contrast in morphology between high-rise housing and Lilong seems to be a sudden mutation (Figure 1.3) but actually suggests a gradual housing typological evolution lasting over a century. Four major types of Chinese living system

will be discussed from Chapter 1 to Chapter 4: 1) Courtyard housing, a family-centred living system, developed in rural society; 2) Lilong housing, a community-centred living system, formed at the beginning of urbanization and industrialization; 3) Work unit, a compact living system, developed in an economically difficult period; 4) Private development residential housing, developed after economic reform (Figure 1.4-1.7). In each stage, I will use a diagram to demonstrate the transformation of spatial configuration in these living systems. And then by connecting the illustration of spatial configuration in each stage, one can see the trends in transformation (Figure 1.8). After I introduce four typical housing typologies in four periods, I will illustrate the transformation as an evolutionary road map. Having the housing transformation analogous to organic evolution, I will discover the inherited genes in Chinese housing system and impacts from external factors in each phase of evolvement.

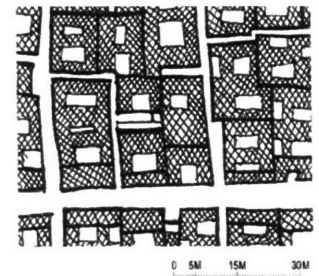

Figure 1.4 Courtyard housing

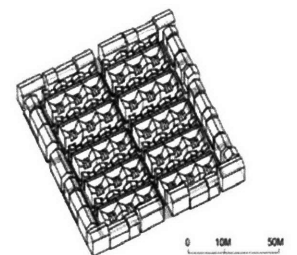

Figure 1.5 Lilong housing

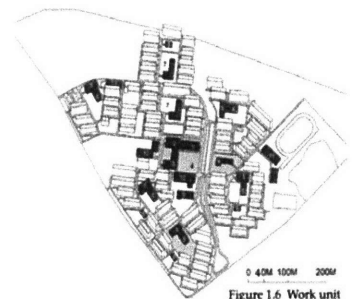

Figure 1.6 Work unit

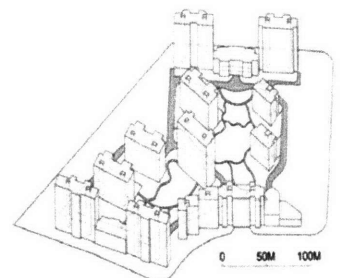
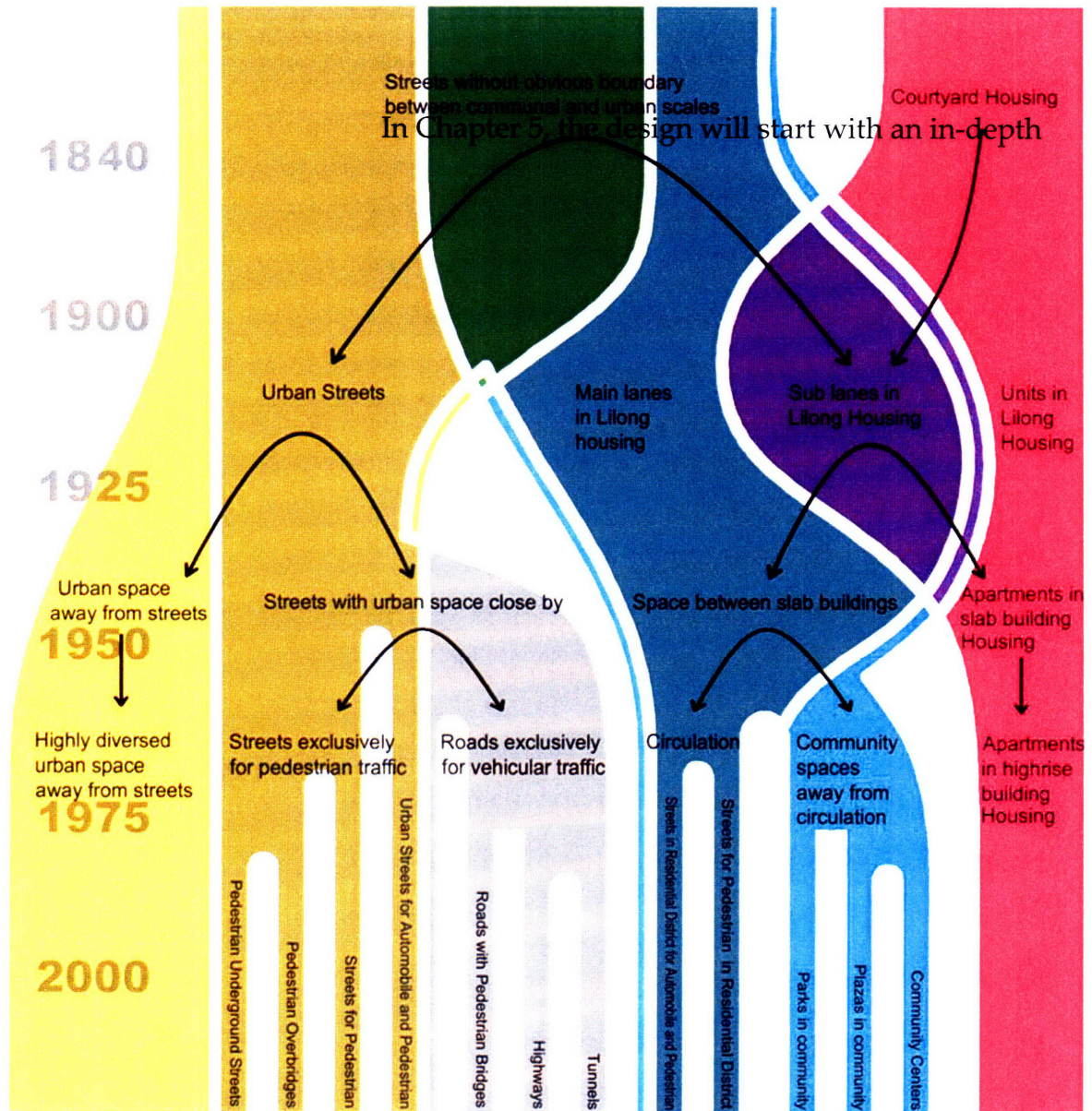

Figure 1.7 Private development housing



By referring to the viewpoints from Jan Gehl, in life between buildings, density of social activities is highly affected by the mixed condition among different programs. I chose the urban spatial configuration as the most representative factor to diagram the morphological transformation of living systems from 1850 to now. Shown as the diagram, four abstract programs, urban life, transportation, communal life, and home life, are selected to represent the spatial configurations of different living systems. Mixed, attached, or isolated conditions among these programs will be represented by overlapping, adjacency and separation among the four colors.

investigation of Lilong housing and relevant urban systems to identify the latent values that are useful to enhance the social life in new urban living contexts. I will focus on the delicate reciprocation between changing architecture and dwelling culture by examining Lilong housing in two perspectives: 1) examine the transformation of this housing prototype, illustrating the process by which architecture adapted to demographic, social, and urban changes over time; 2) inspect the evolution of the social life of Lilong residents by demonstrating how urban living as a dynamic program is altered by nearly static architecture.

Believing that a good design should “bring people together in ways that enhance their enjoyment of the place where they communally are,” (Scruton, 2008, p.3) more specific criticism on communal activities in Lilong will be discussed: 1) the interface defining communal and urban spaces and 2) the interface between housing and communal space. Then I will define that the strategy in design is “Option.” With support from

historical models characterized by particular spatial configurations, a new communal space will be developed to provide 1) option to communicate or separate between households 2) option to share with urban spaces but still keep security.

2. Courtyard housing, a family-centred living system, developed in rural society

Shanghai, as a seaport located at the mouth of the Yangzi River, was founded during the Song Dynasty (AD960-1279). The city wall, the Cheng Huang Miao district today, was built in AD 1553. Inside the walled city, the urban fabric was mostly composed of private courtyard housing, walled and with internal yards open to the air for sunlight and ventilation. In each yard-centered unit, rooms are arranged hierarchically on the ground floor is the living area – south facing rooms usually serve for meeting rooms for important ceremony; east and west wings are more related to daily life, usually serving as reading rooms or dining rooms. The rooms on the ground floor facing north are the kitchen and rooms for servants. On the second floor, south facing rooms are for the elders. East and west facing rooms are for the second or third generation; and north facing rooms are for servants or guests. (Figure 2.1) The boundaries of properties are defined by solid walls, which

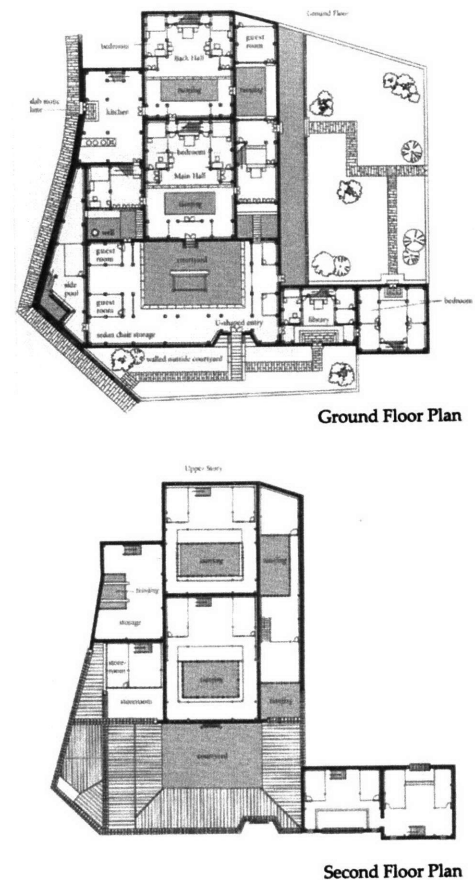

Figure 2.1

provide privacy, tranquillity and safety for households. An integral family-based life style corresponds with the enclosed courtyard-centred housing very well.

Walls, providing introverted spaces surrounding courtyards, have very few openings and few possibilities for either visual nor physical contacts. In a typical urban block, the area, occupied by private courtyard housing appears as a void taken from urban space. Walking into a housing block through a meandering path defined by those solid walls, one can experience a quiet and safe space, only shared by a small number of households.

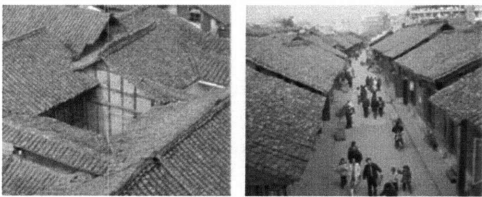

Figure 2.2 Inside and outside the wall

The boundary along the edges of urban blocks is a distinct world. With demands for commerce, walls are set back for certain distance to accommodate shops open to the streets (Figure 2.2). The interface between residential and urban spaces transform from solid walls to be volumes – shops, arranged along main streets and standing back to back to the housing inside. The whole urban configuration can

be described as follows: independent courtyard housings, where diverse domestic lives were carried on in and around the centred yards, were isolated from urban space (Figure 2.3). Urban space can be divided into two categories. One is main streets defining urban blocks, along which many shops are arrayed (brown shows streets, yellow shows shops). The other type is local streets within the blocks, where a few informal shops or vendors exist (illustrated in dark green). In the diagram shown below I applied the colours from the urban configuration diagram to the map of a section of a traditional Chinese city in order to show the spatial configuration in this urban morphology.

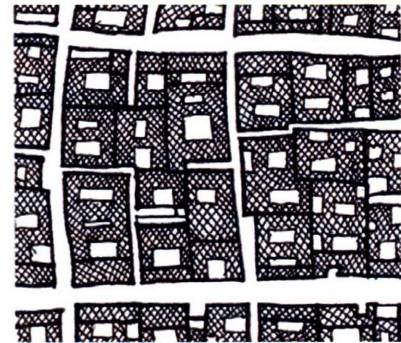
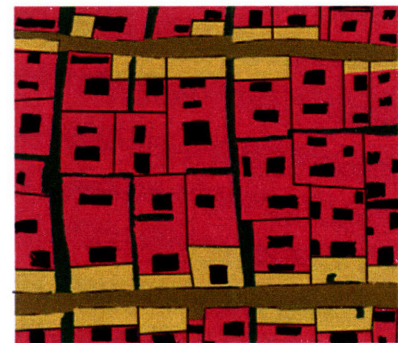
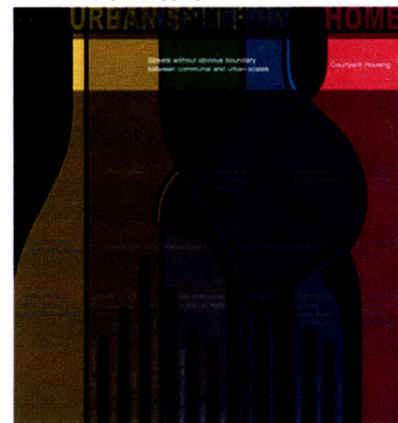

Figure 2.3 Plan of courtyard housing neighborhood



Colored plan of courtyard housing neighborhood showing the relationship among programs



The spatial configuration in courtyard living system

3. Lilong housing, a community-centred living system, formed at the beginning of urbanization and industrialization

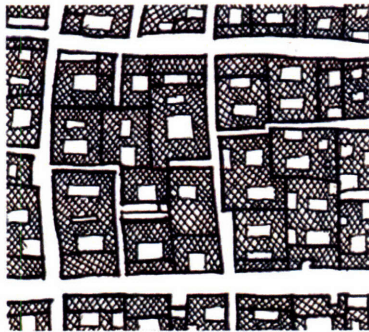
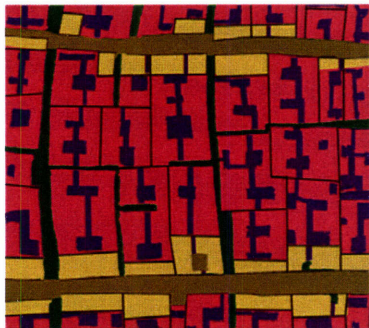
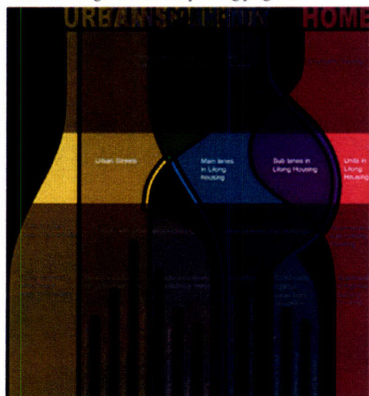

Figure 3.1 Plan of courtyard housing neighborhood



Colored plan of distributed courtyard housing neighborhood showing the relationship among programs



The spatial configuration in distributed courtyard living system

The beginning of the story for Lilong housing is not the birthday of this architectural prototype, but the nutrition for the pregnancy – distributed courtyard housing adapted to the lifestyle of modern time (Figure 3.1). After 1850, economic development and population growth caused a continuous rise in dwelling prices. The owners of courtyard housing started to break up their properties and lease them to tenants such as workers for newborn industries who were coming from the countryside. In the industrialized period, the average size of family decreased dramatically because the occupations of family members were not related to their patrimonial lands as in rural society, but scattered according to the locations of factories. The courtyards, which were once private, were turned into semi-public communal space for those families surrounding them (Figure 3.2).

Moreover, courtyards and light wells were

connected by corridors (illustrated in purple in Figure 3.1), which linked directly to urban space. Therefore the structure of the urban space was reshaped, presenting a fishbone type that is similar to the one in Lilong housing introduced below. However, the layout of this fragmented traditional courtyard housing could not meet the needs of the new society, since their unit plans were designed for the former large-sized families with strict hierarchy, which resulted in the fact that natural resources such as sunlight were allocated unevenly to every room. On the other hand, the strong notion of south-facing is inherited from feudal society, and placed on the top preference by every single family. The contradiction leads to the emergence of a new collective housing suitable to industrial society.

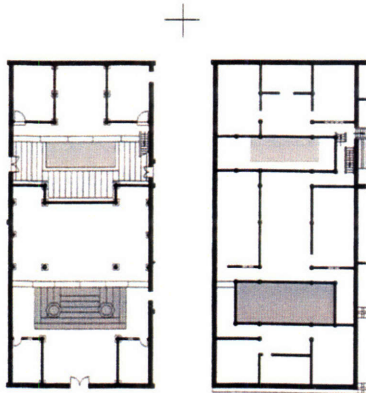

Figure 3.2 Courtyard as a communal space, shared by several households

After the policy segregating the foreign concession areas from Chinese residents was abandoned in 1854, foreign merchants started to invest in building a type of collective housing called Lilong housing. The clients were wealthy Chinese people



British style townhouse



Chinese courtyard housing
Ming Dynasty



Fish-bone-type circulation in Lilong Housing

Figure 3.3 The formation of Lilong housing

from the countryside escaping to the foreign concessions, seeking refuge from the rebellious movement called “Xiao Dao Hui” – “little knife society.” (Zhao, 2004, p.21) Investors hired local builders for the Lilong housing neighbourhoods comprised of a combination of the efficient western row-house layout and the traditional enclosed house plan of courtyard centred living (Figure 3.3).

In the next decades, driven by rising land prices and higher population density, the evolution of Lilong housing implies that the lifestyles of Shanghainese experienced a transition from “the clan/family-based courtyard-centred living to the community-based alley-centred living” (Zhao, 2004, p.49). In the earlier Lilong housing, each house has three or five bays and a centred courtyard enclosed by two wings, thus providing a very similar spatial configuration to that of traditional courtyard housing. Soon, the form of Lilong housing started to transform with rapid social changes. There are three major trends of the

unit plans of Lilong housing: firstly, the number of the bays decreased from three or five to one. Secondly, the number of the floors increased from two to three or four. Thirdly, resulting from these two trends, dimensions, shapes, and positions of yards are forced to change. (Figure 3.4) Because of the increase of floors and decrease of width, the introverted voids such as yards and light wells, on which sunlight and ventilation of rooms relies, are not as efficient as they were in the generous plans of courtyard housing. They are shrunk, squeezed out between the living room and the sub-lane outside. In the later versions of Lilong housing, the



Figure 3.4 Evolution of Lilong housing

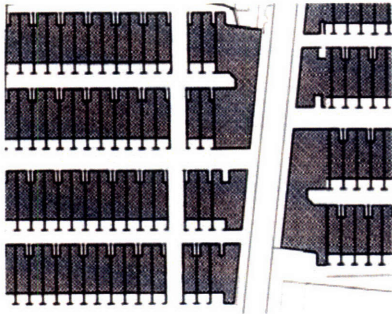
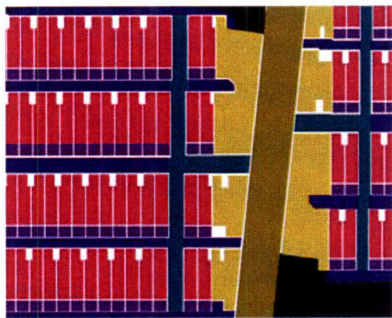
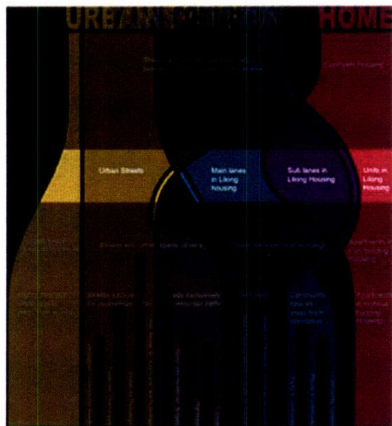

Figure 3.5 Plan of Lilong housing neighborhood, Mei Lan Fang



Colored plan of Lilong housing neighborhood showing the relationship among programs



The spatial configuration of Lilong housing living system

front yard is only defined by a fence or a garden, serving as a buffer space between public and semi-private space, meanwhile, the north light well transformed to be a recess on the north façade for providing natural light and ventilation for those servant spaces near the core of the plan such as staircases and bathrooms. In one of the tightest versions of Lilong housing, (Zhong Lan Li, built around 1930's), the FAR¹ of the whole site reached as high as 1.8, providing smaller unit plans, starting from 86 m², for smaller families. (Figure 3.5)

With the establishment of a community in Lilong housing, urban streets outside are naturally defined by the edges of the housing, which are two to four stories high. "Wai Pu Nei Li" is a standard land use strategy in Lilong housing development, which means the buildings on the edges accommodate shops open to urban streets in their lower part and also wall the communal space inside. The upper and lower dividing way of mixed use between commercial and residential is

¹ Floor Area Ratio

considered to be a densified version of the back-to-back mixed-use strategy in the city composed of courtyard housing. (Figure 3.6)



Figure 3.6

Lilong housing may be seen as a private architectural model for the concept of a compact city and a belief in bringing people together. Units can be reached directly by sub-lanes, which creates a highly mixed condition for activities with different purposes in sub-lanes, such as housework, circulation, recreation, and communicating. The main lanes, a transitional space between more public urban streets and more private sub-lanes, are intensively used as a space for a number of activities such as sports, communication, and commerce. (Figure 3.7 – 3.12)

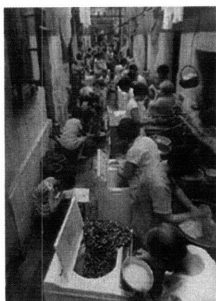

3.7 Housework in a sub-lane



3.8 Reading in a sub-lane

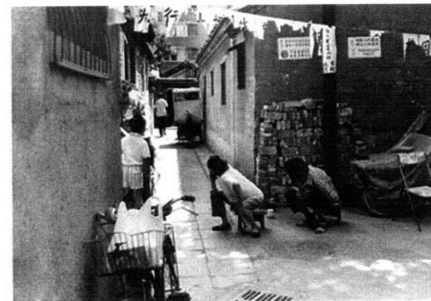

3.9 Neighborhood watching in a sub-lane

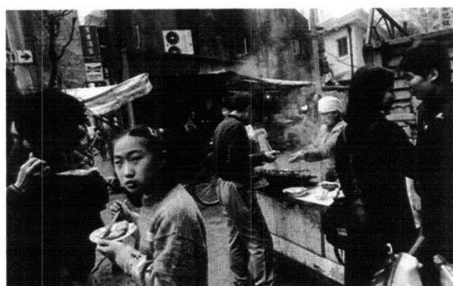

3.10 Small commercials in a main lane

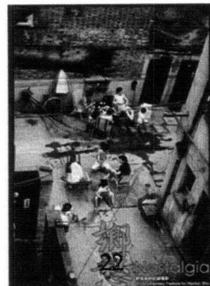

3.11 chatting and enjoying the cool in a main lane



3.12 sporting facilities in a main-lane

According to Jan Gehl's theory, isolation of different programs directly leads to the decrease of the density of resultant (social) activities². In his book *Life between Buildings*, he divides human activities into three categories: they are "necessary activities³, optional activities⁴, and resultant (social) activities⁵." ⁶ Then, he claimed that, to create a good communal space, first of all, we need to improve the quality of environment to encourage optional activities, and second, we need a proper mixture among activities with different purposes in order to stimulate more resultant (social) activities. (Gehl, 1987, p.12)

The Lilong housing, despite its tranquil appearance sustained over a century, experienced

² Jan Gehl, *Life between buildings – using public space*, Van Nostrand Reinhold Company, new york, 1987, p.11

³ Necessary activities include those that are more or less compulsory – going to school or work, shopping, waiting for a bus or a person, running errands, distributing mail.

⁴ Optional activities are those pursuits that are participated in if there is a wish to do so and if time and place make it possible, such as walk to get a breath of fresh air, standing around enjoying life, or sitting and sunbathing.

⁵ Social activities are all activities that depend on the presence of others in public spaces, include children at play, greetings and conversations, communal activities of various kinds.

⁶ Jan Gehl, *Life between buildings – using public space*, Van Nostrand Reinhold Company, new york, 1987, p.11

a social revolution, caused by densification resulting from population explosion and poor maintenance of the buildings. In a typical Lilong housing neighborhood, Zhao Fu Li, composed of three bays units, its population density in 1930 was around 790 people per hectare, which means each person has a living area of 20 square meters. In 2002, even though the average number of family members has dropped from 5.6 to 2.9, the population density rose to 1930 people per hectare, and the living area per capita dropped to 8.2 square meters. In housing neighborhoods with the highest density, this figure is as high as 2200 people per hectare. This increase in the population density pushes the land value to a level without precedent.

In the last 20 years, more than 43% of Lilong housing neighborhoods were demolished and replaced by new developments. However, many Lilong housing neighborhoods still remain in the old city for two reasons. First, some are listed to be preserved as cultural heritage sites. Others are

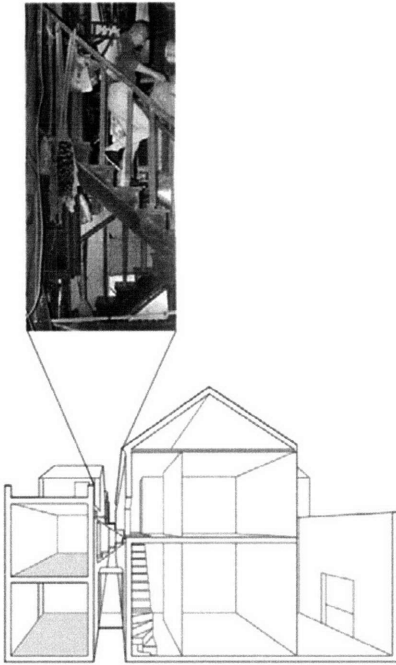

Figure 3.13 Typical Section of Lilong housing

planned to be demolished but linger for lack of funds. In both conditions, residents' way of living has changed greatly compared to the original condition in colonial times (1900-1940), although the architecture has transformed little. A typical Lilong housing neighborhood, San Wen Li, located close to the bund, will be investigated below. This neighborhood, developed in the 1910's, was a typical early Lilong housing, with a relatively spacious living space for wealthy Chinese families. Two-story three-bay-units, with an area of 225 square meters, are divided into two parts by a centre light well. The south building serves as living rooms and bedrooms, and the north building serves as auxiliary spaces such as kitchen, storage, and servants' bedrooms. (Figure 3.13)



Figure 3.14 11 households, 23 people share 1 unit

With an increase in population density of almost three-fold, and decrease in family size of almost 50% at the same time, the investigated unit was broken up and leased to eight households with twenty-three to twenty-eight people plus five people claim that for living here temporarily. (Figure 3.14) Six of the eight households own one

room in the south building; the other two are in the north building. Two shared kitchens locate are in the middle of the north building on the first and second floors (Figure 3.15), above which a shared

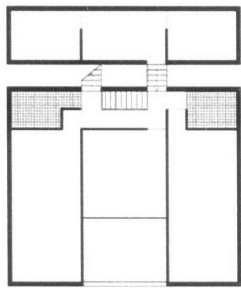

4 house holds share 1 kitchen

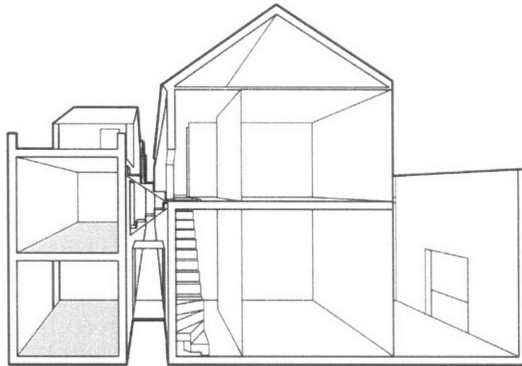

2 shared kitchens and 1 shared terrace



Figure 3.15 shared kitchen in Lilong housing

terrace can serve as a place for laundry drying. Four shared bathrooms are arranged along the north edge of the south building, two for each floor, vented from a light well.

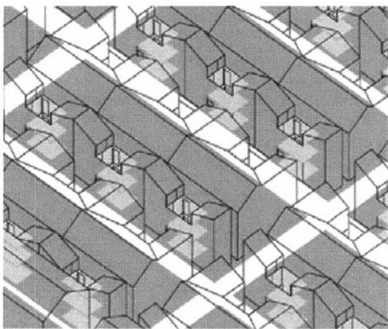
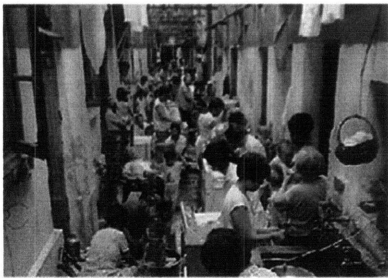

Figure 3.16 Photos and diagram showing the penetration between programs in Lilong housing

With the process of densification, the interface between the communal and residential space changes dramatically. On one hand, the kitchen in a unit that once served as a private kitchen, is now shared by three or four households, causing overlaps in their daily lives. On the other hand, many domestic activities are squeezed out from over-tight indoor living space into the lanes, formally considered to be a semi-public area (Figure 3.16).

In single-room units, Lilong residents had to find flexible ways of living by modifying and using space in creative ways. Living in a single space, residents have to switch programs such as dining, living, and sleeping, so they can make use of the largest available space at a given time. Folding tables and Futon take much time for residents to set them up; however, this flexibility in living creates the possibility to be accommodated in the dense Lilong housing. (Rooney, 2003, p.23)

In shared kitchens, a strong and subtle relationship

between households is built because of the ultra-intensive interaction in their daily lives. When sharing facilities or spaces, people sometimes would quarrel for trivial conflicts. However, most of time, they show tolerance and are ready to help each other. For instance, if a housewife who lives on upper level wants to wash dishes, she probably asks her neighbor downstairs to stop using the faucet in order to have greater water pressure. People are warmhearted to the neighbors with whom they have a good relationship, and indifferent to those they dislike. Sharing engenders ultra complicated interpersonal relationships. Among friends, strangers, and enemies, themes of drama are stages in Lilong daily life. (Lok, 2008, p.18)

In streets, such an intensive use of communal space not only results from the scarcity of living space, but also from the spatial configuration in Lilong, where there is no specific communal space is there. Yet lanes, which serve as circulation and also set-back space for natural light between bar

buildings, are perfect as communal spaces for several reasons. Firstly, lanes enable diverse programs because of their horizontal extension. Compared with the staircases in mid-rise housing and elevators in high-rise housing block, these horizontal linear spaces play many roles in the daily life of residents. Second, the programs in lanes are diverse and mixed: circulation for biking, walking, and strolling; working spaces for laundry; preparing for cooking; relaxing space for reading the newspaper, playing games, or even taking a nap. When people meet with each other, they stop to greet, gossip, or watch a chess game. Its undefined identity is the origin for dynamic activities. Third, the configuration allowing for programs to overlap is based on a dense interlacing of residential and communal space, in contrasting to the isolation between residential and communal space in high-rise housing. The ambiguity between different programs results from strong connections between residential and communal spaces. At dusk, if a housewife feels too crowded in a shared kitchen, she takes a basket of

vegetables outside to clean, enjoying the sun set. In morning, an old man opens the front door and hangs his bird on a hook in the wall, and then plays Taiji and greets passersby from time to time. There is also a strong connection between communal and urban spaces. A school girl doing some leisure exercise in main-lane would buy some fresh lichee from a vendor who walked into neighborhood from streets outside. A transition from urban to communal, and then to the residential, is built.

4. Work Unit, a compact living system, built in an economically difficult period

“To be sure, scarcity, the condition of not having enough, is not a natural given, instead, it is a constructed notion whose meaning shifts across time and space” (Lu, 2006, p.7). After 1949, with the founding of new China, and the intend to control inflation and reduce consumption, the central government adopted a planned economic system to accumulate material, financial and personnel resource to support the recovering industry and ensure the basic needs of people. Under the “high accumulation and low consumption” policy, the importance of the primary-industry and secondary-industry is over-emphasized and the tertiary-industry is ignored. Commercial and recreational facilities in the city are undeveloped because of the limited resource from central government. In this social background, the Work Unit, a dual social and economic entity, was created to provide working place, residence and other necessary daily-life

facilities such as canteen, sports field, schools, kindergarten, club, nursery, clinic, and bath house.

(Figure 4.1)



Figure 4.1 Typical Work Unit, New Village, Shanghai, 1958

The system of the Work Unit provided many solutions to lower living consumption and supporting primary and secondary industry.

Firstly, guided by the principle of “production first and livelihood second” (Lu, Rowe, and Zhang, 2001, p.105), the Work Unit was designed for the spirit of solidarity, where people were supposed to share many facilities such as kitchen, bathroom, washing room, and sunny court. By being educated in the spirit of collectivism, most people could enjoy their collective life in daily living, which is also helpful to enhance their working morale. Secondly, simple and basic facilities provided in work units were helpful to purify their minds and diminish their desires. People were encouraged to be proud of sacrificing comfortable life and dedicated themselves to work or study. Thirdly, for the government because necessary facilities are provided to be shared in a residential neighbourhood; collective housing can be built in the tightest area both for living and sleeping by not including kitchen or bathroom. This strategy was very effective to solve the acute housing shortage in a difficult period. Finally, work units are designed to be a self-sufficient working and living entity, and then the personnel exchanges with

other parts of city are minimized. Therefore the budget on urban transportation and infrastructure can also decrease. (Lu, 2006, p.43)

Housing form is also transformed to a unique morphology. Like the distributed courtyard housing, the prelude to Lilong housing, distributed Lilong housing reflected the needs of modern people (Figure 4.2). As the population density kept rising, Lilong housing as a type of multi-story, private entrance row housing was not able to accommodate more and more families. Their owners started to sublet rooms to other families. Although the physical structure in Lilong housing changed a little, the spatial structure was redefined by the different way of using it. The entrance and staircase in unit were no longer private, but shared by several families. Diagrammatically, the spatial configuration in Lilong housing has been basically transformed to the one in slab buildings.



Figure 4.2 Distributed Lilong housing

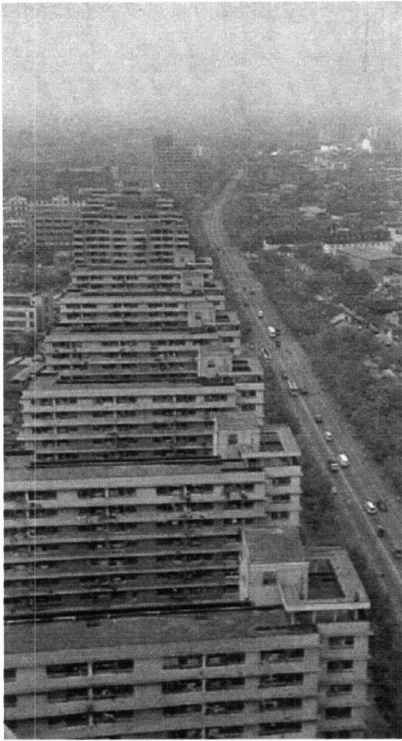

Figure 4.3 Slab building in work unit

However, a new housing typology needed to be developed to reach higher FAR, to provide better sanitation quality, and to equalize the natural resource allocation to all the units. Housing slabs, formed by the strong notion of preference for south facing and the notion of egalitarianism, show a monotony of form with parallel and equal-height slab buildings at uniform spacing (Figure 4.3). Employing six-or-seven-story slabs, the ratio of the distance between buildings to the height of the south building is at least 1 inside third ring, or 1.2 outside the third ring (Figure 4.4).

The whole city was unified by this type of planning. Communal space is divided evenly and without any enclosure. As private courtyards disappeared, sunlight and ventilation of units came to rely on outer walls.

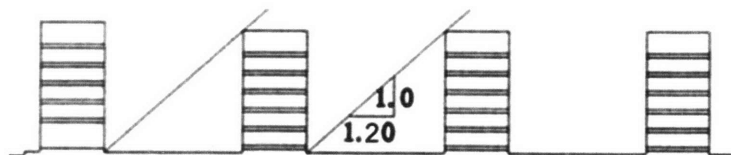

Figure 4.4 Sunlight regulation

Entrances of flats are arranged on each floor and then connected to communal spaces by staircases

which are hardly considered to be a suitable communal space. Since the connections between them are elongated and weakened, the communal space cannot be reached as the extension of the dwelling. Standing in the open spaces between the slabs, which often connect spatially with the urban space outside, residents have difficulty feeling the sense of belongingness that can be clearly felt in lanes of Lilong housing. Similarly, urban spaces such as streets outside are also not well defined by the mass of housings, but fences instead. Because of the increase in size of the city and in speed of commuting, the scale and the morphology of the city starts to transform from small to big, enclosed to open, while the city is sprawling at the periphery. (Figure 4.5)

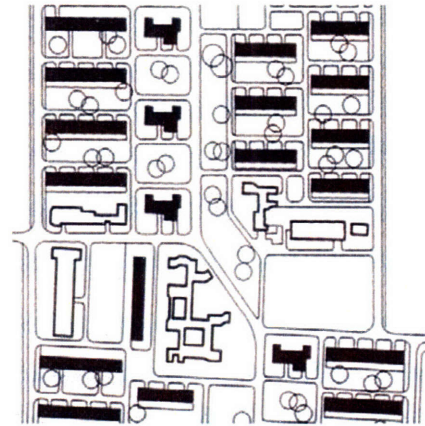
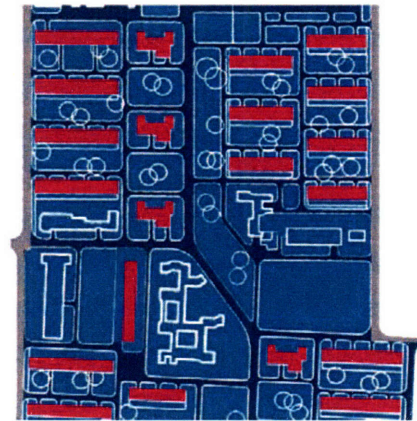
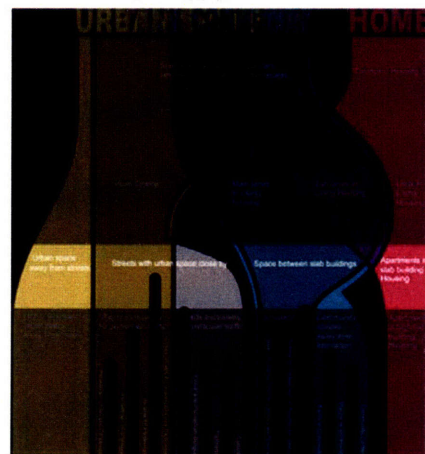

Figure 3.1 Plan of work unit neighborhood



Colored plan of work unit neighborhood showing the relationship among programs



The spatial configuration in work unit living system

5. Private development residential housing block, after the economic reform

After the 1978 social and economic reform, the planned economy was replaced by a “socialist market economy with Chinese characteristics”, which resulted in reform of the housing market as well. With the development of a real estate industry, planning of the residential block and housing design shifted from supply-driven welfare housing to demand-driven commodity. The living area per capita and quality of living space improved markedly due to the competition brought by market economy (Rowe, 2005, p.121).

Chinese housing morphology changes again through this housing market reform. Since the purchase of housing is considered to be the most important investment in a person’s life, his or her housing requirements become much stricter than that on welfare housing. Moreover, one’s

experience with poor sanitation conditions such as insufficient natural light and ventilation, further strengthen the preference for south facing units. Additionally, with a lack of affordable heating, cooling, and mechanical ventilation, east-west facing units are not acceptable. In order to meet the needs of the buyers, providing best the quality in south exposure for individual space dominated the design of commercial residential housing, while the design of the collective space such as community has to be subject to the former rule. Hence, the retrogression of the built-environment in the residential block is inevitable. Landscape as a design element, becomes the decoration of the problematic communal space, which does improve the environment significantly, but is ineffective to enhance social contacts among people.

Being driven by demand is only one of the major solutions to reach the ultimate goal – maximum profit. Other efforts are also being made to pursue higher profit. Increase of building density by introducing new housing typology, such as

high-rise point tower, is the most effective way. Being restricted by sunlight regulations, the typology of the slab with a depth of less than 13.5m has as its maximum FAR at 2.2. Since point towers do not cast a continuous shadow as do slabs, it is the optimal choice when pursuing an FAR higher than two, and also protects the communal space from extensive shadow. Building codes for point towers are accordingly different from those for slabs. For example, for towers lower than 100m, a minimum distance of 35m is required between any two.

Consequently, the spatial configuration as well as built-environment in housing neighbourhood transform according to the alteration of the building form. Observing the recent prevailing model, high-rise housing, we can discern that as the floors increase, shared common space is transformed from introverted to extroverted. For instance, lanes in Lilong housing are an introverted void space on which lighting and ventilation of units rely. Windows and doors as

the openings linking home and common space face to others surrounding the common space. The elevator hall way in high-rise buildings is usually located near the core of the building, hardly able to be lit or vented. Therefore few windows will open to the space, and doors only open for access. A looser connection between units and communal space results from the vertical circulation – the elevator, a closed capsule is exclusively for circulation and has little chance to interact with other programs. People’s movements are controlled by mechanics (Figure 5.1). Units in high-rise towers are more physically isolated than the ones in Lilong housing because no effective communal space is nearby (Figure 5.2). Moreover, since open spaces are not well defined by buildings and have a weak connection with housing units, it hardly provides the sense of belonging and security compared to that of Lilong housing. Moreover, because the principal circulation relies on elevators, horizontal circulation is highly simplified and physically or even visually separated from other communal

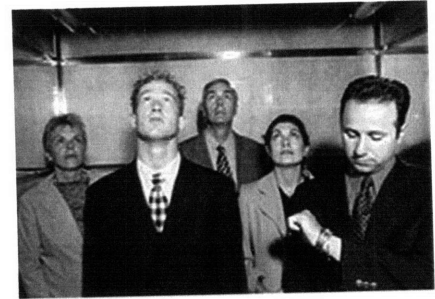

Figure 5.1 People in elevator



Figure 5.1 People in home

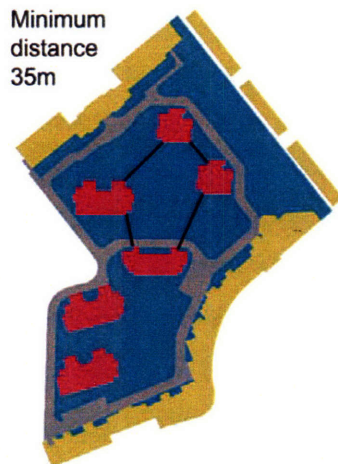

Figure 5.1 People in community

spaces such as play ground, green land (Figure 5.3). This trend leads to the separation of the activities with different purposes (Figure 5.4).



Figure 5.4 Plan of high-rise housing neighborhood



Colored plan of high-rise housing neighborhood showing the relationship among programs

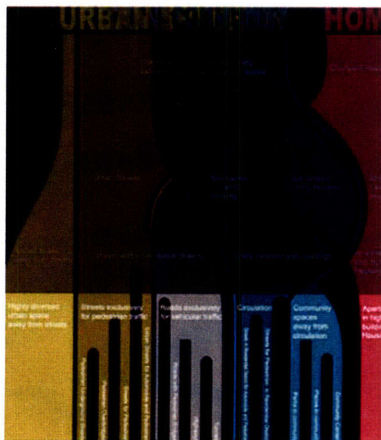

The spatial configuration in high-rise housing living system

6. Conclusion for the housing transformation study

With the general information provided in previous studies, this part of the research will be focused on more critical study on the transformation of housing typology and urban morphology. To consider the transformation of housing typology shown, the diagram below (Figure 6.1), relates

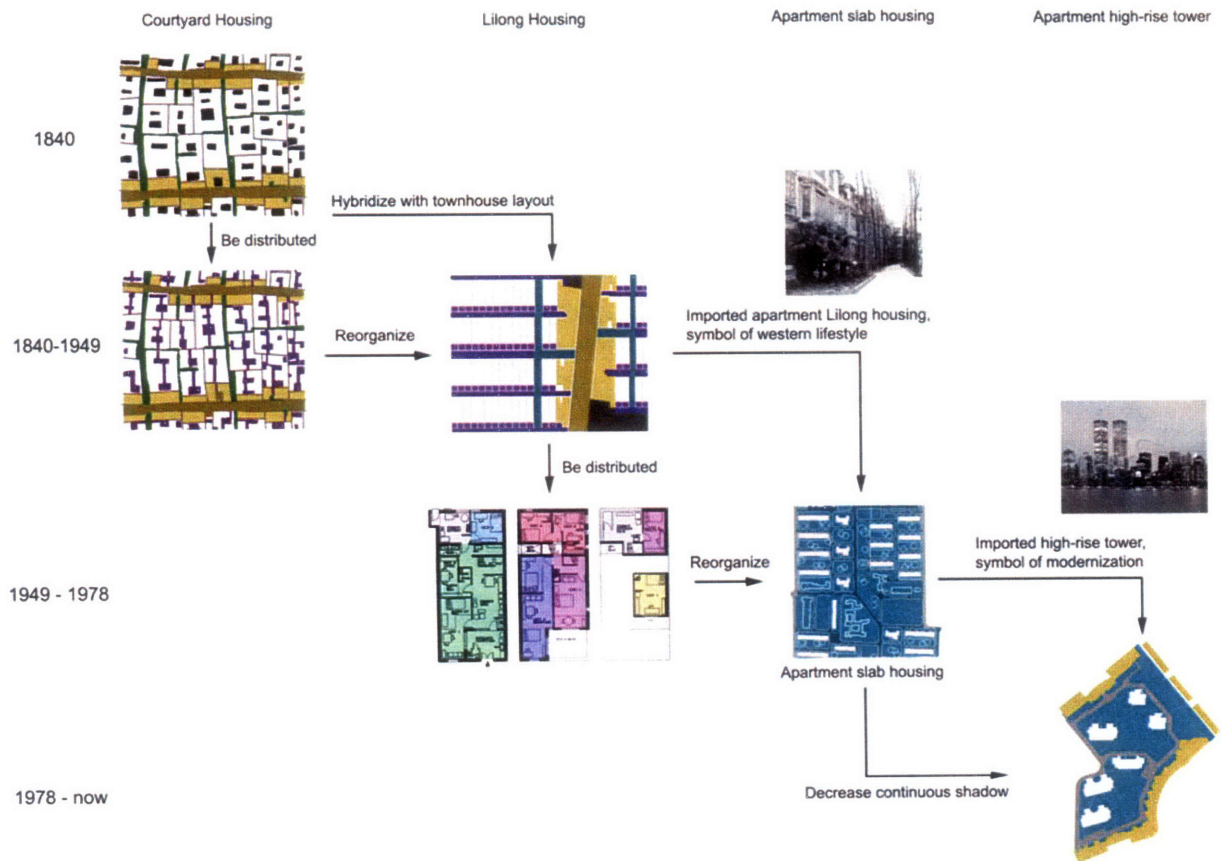

Figure 6.1

types of urban living systems and periods of time separately. Along the X axis four types of urban housing systems are arrayed in the chronological sequence of their emergence. The process of the transformation presents a complexity, which is basically composed of two interactive paths: 1) the one above is the external influences to cause the changes directly, 2) the one below is intrinsic factors that create foundations for the changes. In the transformation diagram, horizontal rows show different periods in history, meanwhile, vertical columns present different typology. There are two different ways to complete each step of transformation. The process goes downwards first and then rightwards, showing the process by social changes directly, which result in the fact that residents use the same dwell in different ways. These soft trends are considered to be the premise of physical transformation in architectural typology. The other process, going rightwards first and then downwards shows the changes by selection, in which the prevailing housing typology is one of many typologies introduced

from out of the country. They survive in their adaptation to local society.

7. An ideal compact neighborhood that brings people together

Recently, Shanghai government enacted a new regulation for residential buildings, suggesting a maximum FAR of 2.5 for the inner city. This would be a great opportunity to revive low-rise high-density housing, not only because the FAR is possible to be achieved by low-rise housing, but also the consideration of living quality for individual and common space become another force against the pursuit of higher profit.

Here is a brief description of my proposed low-rise-high-density housing complex design in Shanghai. The initial concept focused on “option” of keeping privacy or seeking communication, generated from a comparison between densified Lilong housing and high-rise residential housing (Figure 7.1). This interface is composed of a series of common spaces shared by adjacent neighbours, which connect private living space with a bar-shape space containing very tight kitchen and

dinner spaces. The tightness encourages people to go out to use the shared space. Being a buffer space that enables people to choose being away from common space, the idea of elevated streets will be fully supported. They will serve as a major circulation to replace vertical circulation such as elevator or staircase (Figure 7.2).

The concept of elevated streets is also generated from the comparative study between Lilong housing and high rise housing. Horizontal circulation that can access private entrance will be inherited for keeping strong connection between housing and communal spaces. Some of those lanes once at the ground level in Lilong housing will be elevated to different levels in order to access those one or two-story high units on different levels. Elevated streets on different level will be connected by the vertical circulation – a series of continuous ramps combining with public spaces. Compared to conventional housing, the vertical circulation will be a much more positive element in my design.

At a larger scale, the interface between urban and communal space will be discussed noting the fact that the needs for increased urban space and transport efficiency conflict with the needs for a tranquil human-friendly community. Two precedents, Newbury Street in Boston, as a mixed-use residential commercial district, and Tudor City a tranquil residential neighbourhood in New York that is able to coexist with high speed passing-by traffic will be cited as examples with new urban configurations (See Appendix). In this design, the concept of “option” is also used to deal with the interface between communal and urban space. An optionally penetrable interface between communal and urban spaces will be proposed, via which urban space such as commercial or recreational space can penetrate into the territory of community without connecting communal space directly but space such as commercial or communal space. The facilities in urban space are accessible both for people from the residential block and those from outside. Underlying security problems are controlled by neighbourhood watch

from central communal space. The space below the elevated surface is for commercial use (Figure7.3), and able to be accessed both from communal space above and urban space below.

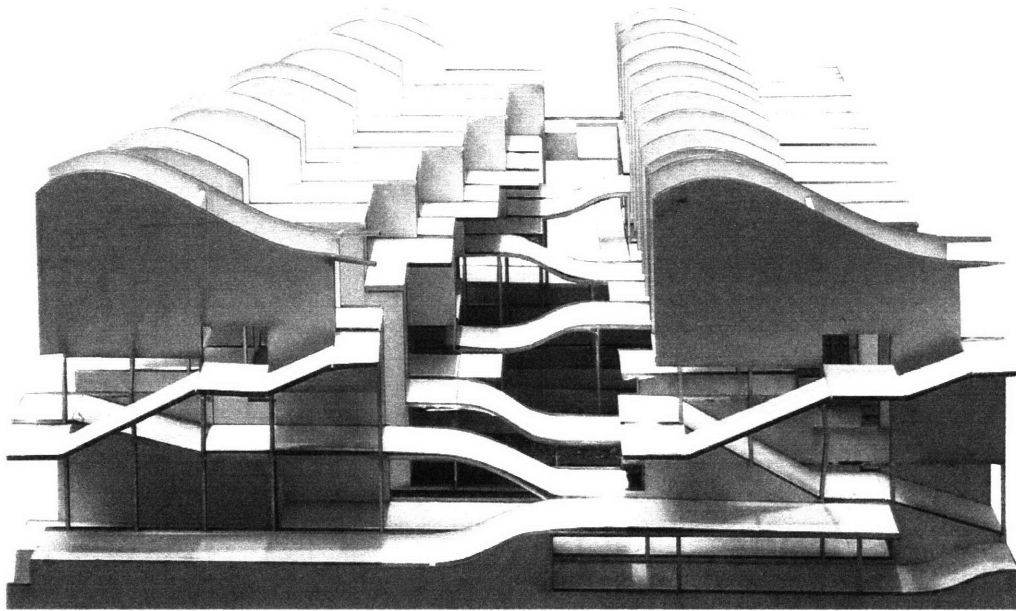

Design



Typical Floor Plan with eight self-contained units in High-Rise Housing

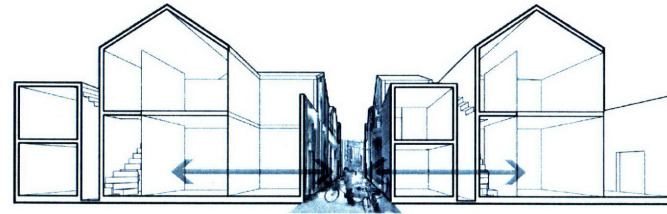

Street as shared living room = high density of social activities

50

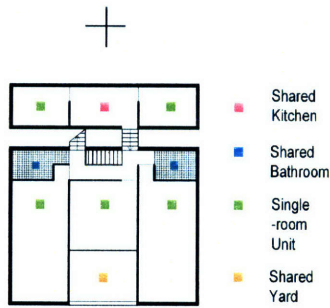

Typical Floor Plan with Five Single-Room Units in Lilong Housing



Stacked = High building density

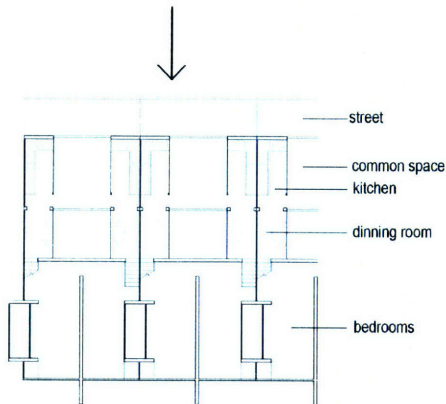
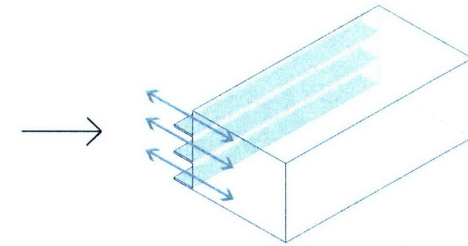

In high-rise housing, residents have few chances to have social contact, while in Lilong housing people have to share for lack of space. "Option" is the keyword in my design. I set the private rooms facing the south and pull the most public part in one unit into common spaces connected by a street. The bar is tight but contains all basic facilities and space. The tightness encourages people to use shared common space.

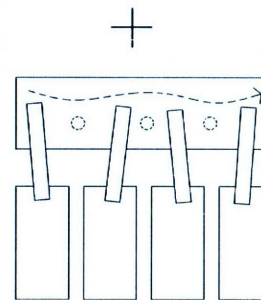

Providing a buffer space between residential space and public street, this floor plan enables the idea of stacked streets, which aims to introduce public space into buildings.

Elevated streets also create some problems such as natural lighting, ventilation, and too much common space. Which space will be given southern exposure, public or private should also be discussed.

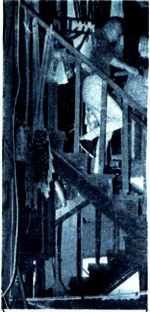

A section of one type of Lilong housing provides some solution to these problems.

Light-well provides better natural light and ventilation, split-level creates more flexibility between shared and private space.

51

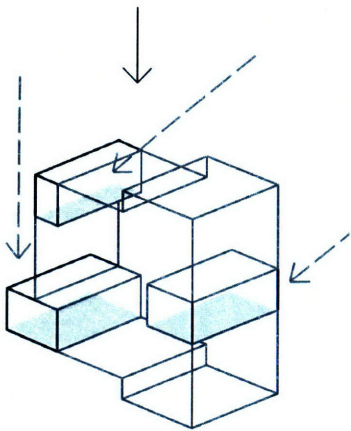
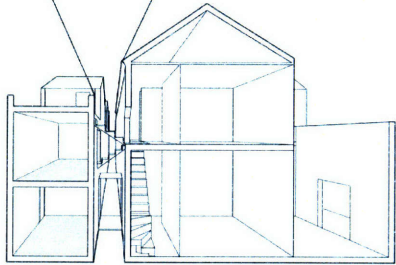

Good natural light for every elevated street



By using split-level, each street can serve two stories. Although there is one south-facing common space, every unit has at least one south-facing room.

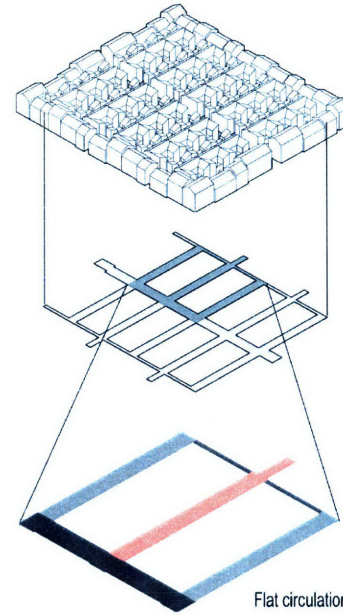
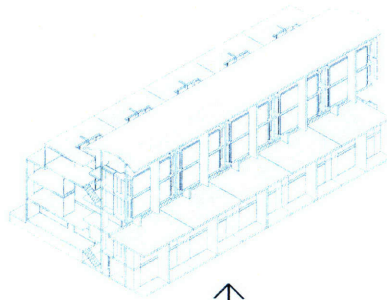
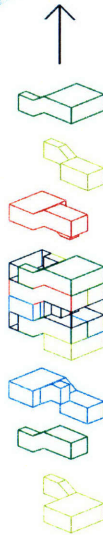

- Entrance lane
- short-cut lane
- Sub-lane
- Main lane

Flat circulation



With one section of a bar building, three elevated streets and the connections between them will be imposed the spatial configuration in Lilong housing

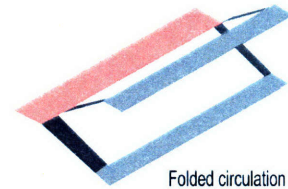

Folded circulation

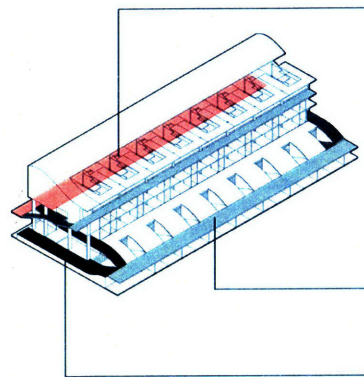

South-facing elevated entrance lane can receive more sunlight in winter

Lighter traffic on ground floor more green space

Ramps are combined with common spaces serving as a main lane

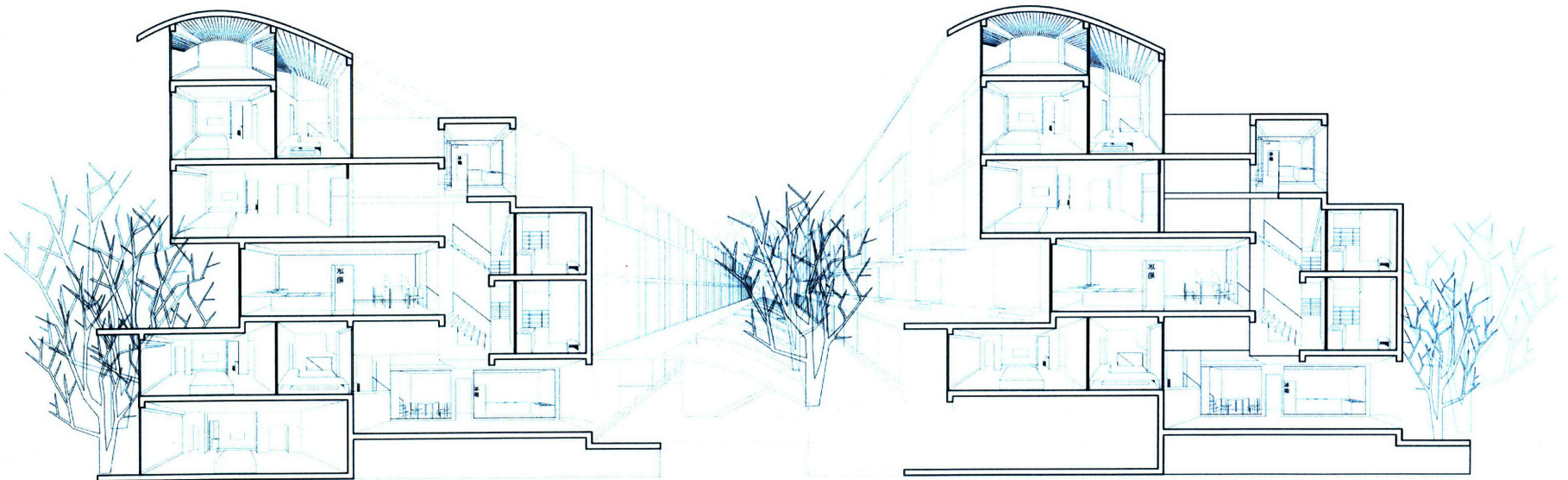

8. Conclusion

Seeking to demonstrate design through research, I have employed a systematic case study as the method to discover the relationship between urban living and urban morphology. By comparing these models, I can identify qualities that once existed in previous models and also the trends of modern life. Aware that people's daily life is switching from communal to domestic and urban space due to changes of lifestyle, we have to admit that many social problems are created by the isolation of physical contact between households, additionally there are social, economic, and ecological problems created by the overloaded urban transportation system, on which most urban life depends. Specific strategies to encourage social life need to be developed. Two interfaces 1) between residential and communal spaces and 2) between communal and urban spaces are employed. "Option" is the keyword to operate at these two interfaces. Communal spaces can be used as circulation and also domestic spaces will be created by interface

between residential and communal space. The interface between communal and urban space creates options for communal spaces to serve as public spaces. Pursuing options that can be projected between and among these interfaces, a compact neighbourhood that can bring people together again is developed within the context of contemporary Shanghai urban living.

Appendix: Two urban projects as precedents for the concept of a compact neighborhood

1. Back Bay, Boston – living coexists with commercial

The Back Bay area is recognized as the best mixed-use neighbourhood in the center of Boston, composed of restaurants, commercial, establishment, churches, museums, colleges, and residential buildings. It was designed by Arthur Gilman with Gridley James Fox Bryant in 1870s, and built for middle-class residential purposes after filling the back (landlord) bay area of Boston. The design follows a strict grid and applied European design elements, such as the boulevards, and wide-sidewalks.

The spatial configuration of the combination of commercial and residential space is the most successful part of this area, which brought urban living into the originally residential street life. The general layout is that the commercial stores take the ground and first level of the building, facing

the street, while the upper floors are used for living. Those two parts are separated by two entrance doors for the purpose of control of entry and privacy of living. There are more specific spatial details, which veritably enriched the activities happened between the low floors and the wide street sidewalk. There are five types (figure 8.1).



Figure 8.1

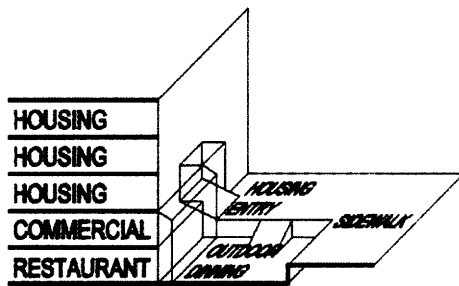

Figure 8.1 Diagram of the sidewalk in Newbury Street

The first one the open public space in front of public buildings. Vendors and small floating businesses are able to make use of them. The second type is the big brand store that needs a more monumental sense for its design, usually leaving a big empty side walk before their store. The third one is of small shops are sharing commercial space by split levels. The fourth one is of stores that start to take advantages of the wide sidewalk space. The last and most complicated one shows different levels of space use (figure 8.2).

All the facilities in the lower floors of the buildings can be used not only by local residences, but also by the public. Nevertheless, because of the good control of the privacy by the spatial design method, different programs in Back Bay coexist and co-operate and finally form a combination of the most enjoyable urban space and one of the most desirable places to live in the city.

2. Tudor city, New York-- a secured housing project without a wall

Tudor city is a historical residential area in mid-town Manhattan, composed of twelve buildings (around ten-to-thirty-story height), green parks, three thousand apartments, six hundred hotel rooms, restaurants, laundry, café, stores, church, etc. The site is encircled by 1st Avenue, 40th Street, 2nd Avenue and 44th Street, near United Nation Plaza.

In the 1920s, the area that used to be slums and a low-class residential area, was designed and developed by Fred French and H. Douglas Ives, as a utopian urban residential community in Manhattan for middle-class residents, including comprehensive facilities and delightful natural conditions. By its specific topographic design, Tudor city has become a quiet and comfortable living area, isolated from the chaos of Manhattan.

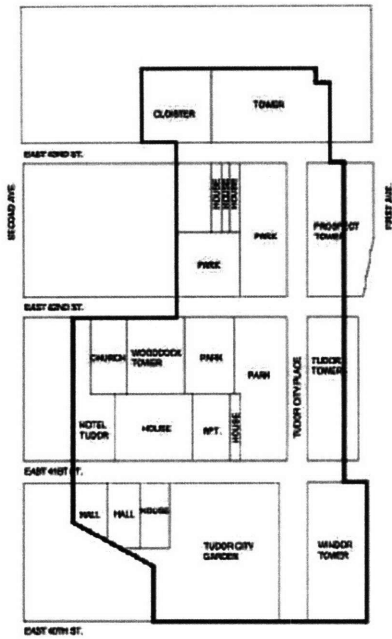

Figure 8.3 Plan of Tudor City

The design of Tudor City follows the topography of the site and uses a split-level system to separate major automobile traffic and create a secured, quiet residential community. The natural terrain of the site is that the west side adjacent 2nd Avenue is higher than the east side adjacent 1st Avenue. The designer created a plateau-like base of the community at the height of the 2nd Avenue and a tunnel for the major automobile of 42nd street going to the 1st Avenue. Most of the activities happen on the platform. (Figure 8.3)

The most prominent feature of Tudor city is the 42nd street goes through from 1st Avenue as a tunnel, which provides several benefits for the residential community. First, urban space is naturally brought into the community by using the stories below the lobby level and finally makes the community self-sufficient. Second, it efficiently separates the residential area from the public, which makes the area quiet and private naturally. (Figure 8.4)



Figure 8.4 See 42nd street from inner street in Tudor City

Because of the no-walled security, facilities for Tudor city residences can also be used by the public. However, the split level of the public and community means the general public does not enter this area. In other words, the public has the option to use the urban space which is infiltrated into the residential community, but the physical design makes the probability much lower. What's more, the spatial configuration makes this area relatively more private and safe like a community, which is different from the sense of normal residential area.

Bibliography:

Arkaraprasertkul, Non. "Toward Shanghai's Urban Housing: Re-Defining Shanghai's Lilong" Proceeding of the Sixth China Urban Housing Conference in Beijing, P.R. China (Hong Kong: Center of Housing Innovations, CUHK, 2007)

Dawkins, Casey J, "Regional Development Theory: Conceptual Foundations, Classic Works, and Recent Developments," *Journal of Planning Literature*, Vol.18, No.2 (November 2003)

Gehl, Jan. *Life between buildings – using public space*, Van Nostrand Reinhold Company, new york, 1987.

Hammond, Paul H. *Community Eclipse and Shanghai's Lilong*, Thesis, University of Missouri, May 2006

Huang, Lei. "Housing Development in the Context of Modernization, Urbanization, and Conservation of Chinese Traditional Cities: Beijing, Shanghai, Suzhou," D.Des. dissertation,

Jacobs, Jane. *The death and life of great American cities*, Random House, 1966.

Lok, Leslie. *Final Term Paper for Contemporary Architecture and Critical Debate*, 2008.

Lu, Duanfang. *Remaking Chinese urban form: modernity, scarcity and spaces 1949-2005*, Routledge, 2006.

Lu, Junhua. Rowe, Peter. and Zhang, Jie. *Modern urban housing in China 1840-2000*, Prestel, 2001.

Marshall, Alex. *How cities work: suburbs, sprawl, and the roads not taken*, University of Texas press Austin, 2000.

Rooney, Nuala. *At home with density*, Hong Kong University Press, 2003.

Rowe, Peter. *East Asia modern: shaping the contemporary city*, Reaktion Books, 2005.

Sherwood, Roger, *Modern Housing Prototypes*, Cambridge: Harvard University

Scruton, Roger, *Cities for Living*, City Journal, Spring 2008, vol. 18, no. 2

Zhao, Chunlan, From Shikumen to new-style: a rereading of Lilong housing in modern Shanghai, *The Journal of Architecture* Volume 9, spring 2004.