

Tectonic Studies in Beichuan: Rebuilding the Beichuan Middle School

by
Christopher Taylor

B.A. Economics, Environmental Studies
Tufts University, 2002

Submitted to the Department of Architecture in partial fulfillment of the requirement for the degree of Master of Architecture at the Massachusetts Institute of Technology, February 2009

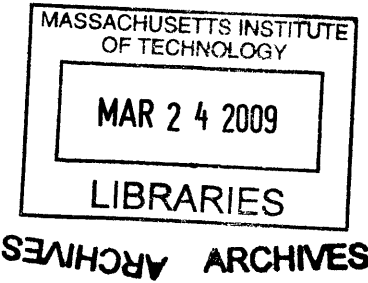

Signature of Author: _____

Christopher Taylor
Department of Architecture
January 15, 2009

Certified by: _____

Weijen Wang
Visiting Associate Professor of Architecture
Thesis Supervisor

Certified by: _____

Yung Ho Chang
Professor of Architecture
Thesis Supervisor

Accepted by: _____

Julian Beinart
Professor of Architecture
Chair of the Department Committee on Graduate Students

© 2009 Christopher Taylor. All Rights Reserved.

The author hereby grants to MIT permission to reproduce and to distribute publicly paper and electronic copies of this thesis document in whole or in part in any medium now known or hereafter created.

COMMITTEE

Weijen Wang

Visiting Associate Professor of Architecture

Yung Ho Chang

Professor of Architecture

Department Head

Tectonic Studies in Beichuan: Rebuilding the Beichuan Middle School

by
Christopher Taylor

Submitted to the Department of Architecture on January 15th, 2009 in partial fulfillment of the requirement for the degree of Master of Architecture.

ABSTRACT

In his essay, *Studies in Tectonic Culture*, Kenneth Frampton asserts that the built environment is “first and foremost a construction, and only later an abstract discourse.” Building upon this logic, this thesis asks how can we evaluate and critique architecture on its material, tactile and tectonic dimensions, as opposed to the purely figurative, spatial or iconographic representations that have become so commonplace in Modern architecture?

In developing the notion that the architect serves as a link between available resources and the project’s needs, this thesis aims to create a tectonic building system for a new middle school in Beichuan county, Sichuan Province, China. How can traditional construction methods and locally available materials be developed into a sound construction typology that will provide the flexibility to adapt to the various scenarios and sites that are inherent in a large scale project? How can it retain key design issues and serve as a catalyst for the future development of the surrounding community?

Thesis Supervisors: Weijen Wang, Visiting Associate Professor of Architecture
Yung Ho Chang, Professor of Architecture

ACKNOWLEDGEMENTS

Many thanks:

To Mom, Dad and Billie, for their love and support.

Hatsy, thank you for your support, and putting up with years of my late nights, stress and complaining - I couldn't have made it through without you!

My studio team of Erica and Ethan - thank you for all your hard work on this project, I could never have put this together without your help!

Weijen, thank you for your guidance and support.

To all my friends and those who aided and inspired me over the past three and a half years, Thank you!



CONTENTS

11	Background
21	Tectonic Context
53	System
67	Project
97	Appendix
105	Bibliography

BACKGROUND



INTRODUCTION

12|

On May 12th 2008, a devastating earthquake hit the central and northern portion of Sichuan province, China, causing massive damage and destruction. Measuring 8.0 on the Ms scale, it was the strongest earthquake to hit China since 1975. It cost the lives of nearly ninety thousand people, and left millions of people homeless. According to the central government, nearly seven thousand school buildings collapsed and five thousand school children lost their lives, raising questions about the faulty construction methods and practices for these schools.

In the city of Beichuan, which is nestled in a valley approximately 160 kilometers north of Chengdu, over eighty percent of buildings collapsed during the initial earthquake, with aftershocks and seasonal flooding causing further damage. Beichuan, which is home to the

Qiang ethnic minority, was located along a fault line, and the earthquake caused landslides to come crashing down the steep, narrow-sided valley, burying the town in rubble and debris. The town of Beichuan had been relocated once before in the early 1950's for seismic reasons, and now for a second time in it's history, the town will be rebuilt in a new location, safe from the fault line. The ruins of the existing town will be left as a memorial to the many lives that were lost.

This thesis serves as the schematic design phase for a new middle school that will eventually be constructed in the new town of Beichuan. As schools should be considered safe and welcoming environments where parents can feel comfortable sending their children, the collapse of many schools following the earthquake left not only



rubble from the former Beichuan school



14|

trauma to the children and parents who lost family and friends, but shook the community's trust towards the government and educational institutions. As a politically and symbolically important rebuilding project for the Chinese government and people, this project can provide an opportunity to rebuild trust in the educational system, restore the identity of a community that has been damaged both physically and spiritually.

The middle school project outlined in this thesis has been developed in collaboration with Erica Weiss and Ethan Lacy. The design of the overall school campus is a joint collaboration between three universities: Massachusetts Institute of Technology in Cambridge, Tsinghua University in Beijing and University of Hong Kong in Hong Kong. It is sponsored and funded by Yihai Property, Beijing, as well as the government of Beichuan county in Sichuan, supported by All-China Federation of Returned Overseas Chinese.



the site of the former Beichuan School



PROGRAM

16 |

Despite a recent trend towards smaller, decentralized educational facilities worldwide, our program called for the creation of a larger, consolidated school that will accommodate approximately 5000 students from grades 7-12. Because many students come from remote areas within the region, the school must also provide boarding facilities for all of its students.

Due to the large scale of the program, the school will be divided into six clusters; three junior-high school clusters of approximately 600 students each, and three high school clusters of approximately 1030 students each. Each cluster will contain standard classrooms as well as specialty classrooms and laboratories, multi-function spaces, service areas, dining halls, and dormitory facilities. Administrative buildings, athletic facilities, and libraries will be located in a central location on the campus, and shared by all schools.

To facilitate the design of this program, a conceptual site plan has been developed, with 250m by 50m strips running east to west across the site. Each strip contains an autonomous school cluster of classrooms, dorms, and dining facilities. Junior-high clusters are located on the northern third of the site, while high school clusters are located to the south of the central shared facilities.

Because of the reality-based nature of an ongoing development project and its many stakeholders, this project was developed within general rather than specific guidelines. This inherent flexibility ensures that it will be adaptable to different sites and scenarios in the future, while retaining key design issues. As the school will likely be constructed within the first phase of a much larger rebuilding project, it offers the opportunity to act as a catalyst for the project, and create a series of design principles that can be applied broadly.



middle school :: 1800 students
three clusters of 600 students each

teaching
 3,500sm
 15 classrooms +
 specialty rooms

dining hall
 600sm
 kitchen + service

dormitory
 3,600sm
 100 rooms
 6 students / room

shared facilities
 administration / office
 library
 athletic fields / gym

high school :: 3100 students
three clusters of 1,030 students each

teaching
 5,500sm
 24 classrooms +
 specialty rooms

dining hall
 900sm
 kitchen + service

dormitory
 6500sm
 180 rooms
 6 students / room



potential site

Monthly averages

January	Avg low: 37°	Avg hi: 49°	Avg precip: 0.26 in
February	Avg low: 40°	Avg hi: 53°	Avg precip: 0.33 in
March	Avg low: 47°	Avg hi: 61°	Avg precip: 0.59 in
April	Avg low: 56°	Avg hi: 72°	Avg precip: 1.44 in
May	Avg low: 64°	Avg hi: 79°	Avg precip: 2.01 in
June	Avg low: 70°	Avg hi: 83°	Avg precip: 3.13 in
July	Avg low: 73°	Avg hi: 86°	Avg precip: 5.58 in
August	Avg low: 72°	Avg hi: 85°	Avg precip: 5.58 in
September	Avg low: 66°	Avg hi: 78°	Avg precip: 3.14 in
October	Avg low: 58°	Avg hi: 69°	Avg precip: 1.17 in
November	Avg low: 49°	Avg hi: 61°	Avg precip: 0.38 in
December	Avg low: 39°	Avg hi: 51°	Avg precip: 0.13 in

temperature and precipitation data for Mianyang

SITE, TOPOGRAPHY + CLIMATE

18 |

The old city of Beichuan is nestled into the mountains of Sichuan Province, approximately 160 kilometers north of the provincial capital city Chengdu. Despite being relocated once before in the early 1950's, the city was built in a valley on the Longmen Mountain Fault line. More than eighty percent of the buildings were damaged in the May 12th earthquake, and the ensuing flooding caused further destruction. The local government has decided to leave the existing city as it remains, and rebuild in nearby Anxian county. The exact location of the new city and school site remains unknown, although we did visit a potential location, approximately 50km from the city of Beichuan. Currently farmland, the notable characteristics of the potential site include relatively flat terrain, proximity to a major roadway, and adjacency to a medium sized river.

The climate in the region is a subtropical monsoon. There are four distinct seasons, with a moderate winter, and rainy summers. The average low temperature ranges from approximately 38 to 73 degrees Fahrenheit, while the average high ranges from 50 to 85 degrees. It is unlikely that the school will use mechanical heating or cooling.



TECTONIC CONTEXT

What is constant in a thing, its consistency, lies in the fact that matter stands together with a form. The thing is formed matter.

- Martin Heidegger

TECTONIC CULTURE

22 |

The notion of architecture as spatial displacement has preoccupied modern architectural thinking since the late 19th century, and has been mirrored by the phenomenon of drawing architectural legitimacy from other fields. Yet it is our tendency to engage with the built environment through the touch and feeling of surfaces as we move through space. It is the body's engagement with the physical world that allows us to understand both who we are, and the world around us. As Tadao Ando writes, "The body articulates the world. At the same time, the body is articulated by the world. When 'I' perceive the concrete to be something cold and hard, 'I' recognize the body as something warm and soft." It is the tactility and materiality of architecture that engages the body. Heidegger extends this logic by questioning the nature of a 'thing.' He states that the thing itself cannot be defined by its form alone. Instead, we must simul-

taneously comprehend its components and also the logic by which those components are assembled into form.

Kenneth Frampton argues for the expressive potential of construction processes and techniques in his essay, *Tectonic Culture*. Without denying the spatiality and volume of architectural form, he writes that "the built invariably comes into existence out of the constantly evolving interplay of three converging vectors, the topos, the typos and the tectonic." The latter he states, when taken with the site and type, can become in itself a source of legitimacy. The word *tectonic* derives its meaning from the Greek word *tekton*, meaning carpenter or builder. However, as soon as an aesthetic, rather than purely utilitarian perspective to the built environment is introduced, its definition broadens significantly.



Laugier's Primitive Hut of 1753

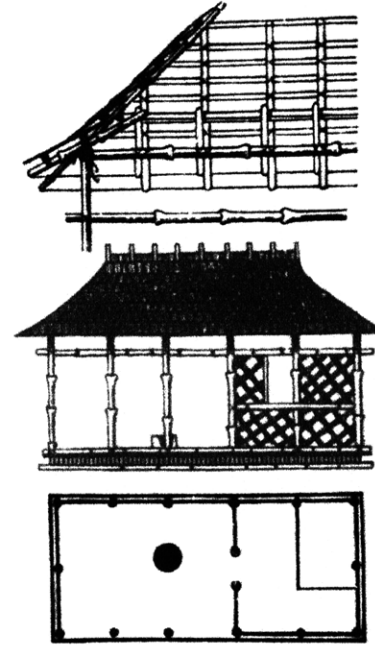

Caribbean hut from the Great Exhibition of 1851 in London

In his work "The Tectonic of the Hellenes," Karl Botticher expanded upon the relationship between the core or fundamental form (kernform), and the artistic or aesthetic form (kunstform). He writes, "the concept of each part can be thought of as being realized by two elements: the kernform and the kunstform. The former is the mechanically necessary and statically functional structure; the latter, on the other hand, is only the characterization by which the mechanical-statical function is made apparent." The kernform here signifies the physical structure of a building, which responds to both material and function. The role of the Kunstform is to make the underlying structure and essence of the building intelligible. The supplemental nature of the kunstform is reinforced when Botticher defines it as the "explanatory layer.... [that] make[s] visible the concept of structure and space that in its purely structural state cannot be perceived." For

Botticher, the tectonic is essentially a complete system that binds both the kernform and kunstform together into a single, comprehensible whole.

In his 1951 essay *Die vier Elemente der Baukunst* (Four elements of Architecture), Gottfried Semper developed a taxonomy of building elements from a Caribbean hut he saw in the 1851 Crystal Palace Exhibition. Elaborating on Laugier's premise of the 1753 primitive hut, Semper proposed a more articulated system including four basic elements: (1) the earthwork (2) the hearth (3) the framework/roof and (4) a lightweight enclosing membrane. From these four elements, he grouped the building processes into two primary systems: the light tectonics of the frame, where linear components were assembled or woven together to form a spatial matrix, and the heavy stereotomics

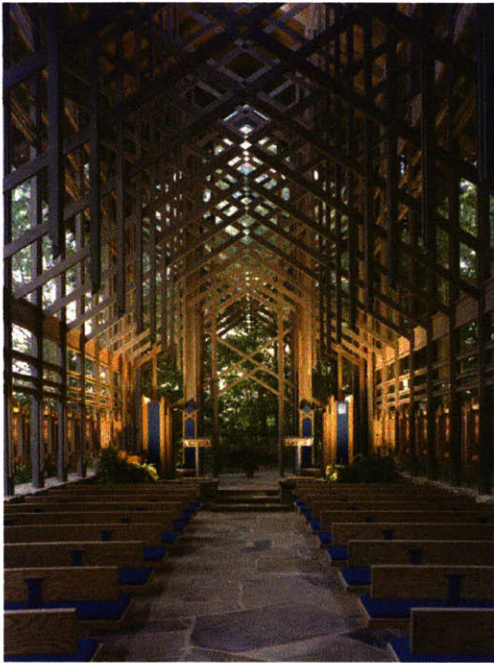

Thorncrown Chapel by E. Fay Jones, Eureka Springs, Arkansas

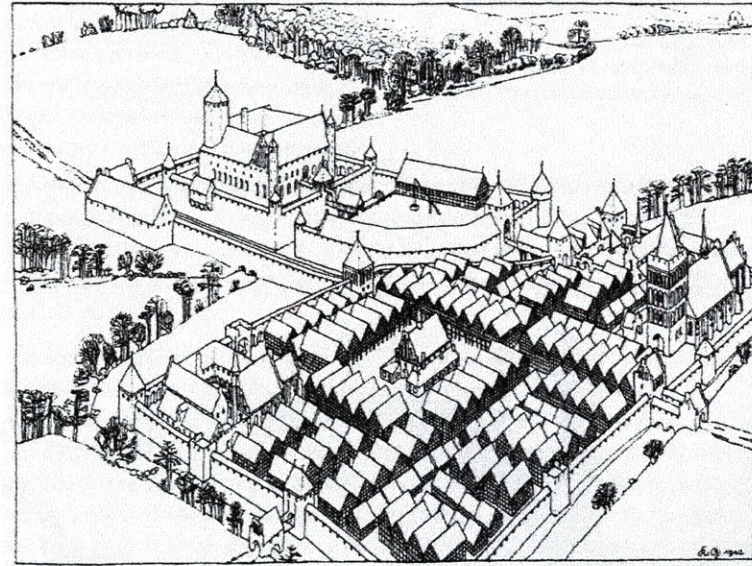

Karl Gruber, Reconstruction of a typical medieval city showing heavily fortified walls and lightweight infill

24 |

of the earthwork, where mass and volume were formed through the piling of load bearing materials. His notion of these light and heavy systems of construction were further articulated through his choice of words: the heavy, fortified wall was called *die Mauer*, while the lighter screen-like system was indicated by the word *die Wand*. Both terms suggest an enclosure of sorts, yet the etymological roots of the latter can be traced back to the German word for dress and to the verb “to embroider.”

Semper’s building elements can be found invariably in buildings throughout the world, but their respective roles can vary greatly, as they are informed by and adapted to local climatic conditions, available materials and skills. In some cases, such as the traditional Japanese house, the stereotomic is limited to point foundations. In the case of E. Fay Jone’s Thorncrown chapel, the chapel’s remote site prohibited larger structural members or heavy equipment to be

brought into the forested site, so lightweight wood framing was chosen as a construction method. The earthen Hakkas houses of China represent a system where heavy mass walls dominate the exterior building form, while the roof and interior partitions are framed with wood. Like the typical German medieval city seen in Karl Gruber’s 1937 image, a clear distinction can be drawn between the heavily fortified masonry walls that are needed for protection from invaders, and the lightweight residential infill of wood framing, wattle and daub. At the far end of the spectrum, the vaulting of roofs usually represents a purely stereotomic system. However, this system can be made to feel lightweight, porous and thin. In Eladio Dieste’s work, for instance, his gaussian vaulted catenary forms allow for thin, lightweight roofs that seem to float above their slender supporting columns. He achieves this effect through the introduction of pre-stressed steel reinforcing, sandwiched between layers of masonry.



Hakka Round Earth Buildings in Fujian



Hakka rammed earth wall, typically 1m thick



TEM factory, by Eladio Dieste



Henri Labrouste, *Bibliothèque Nationale*, 1854

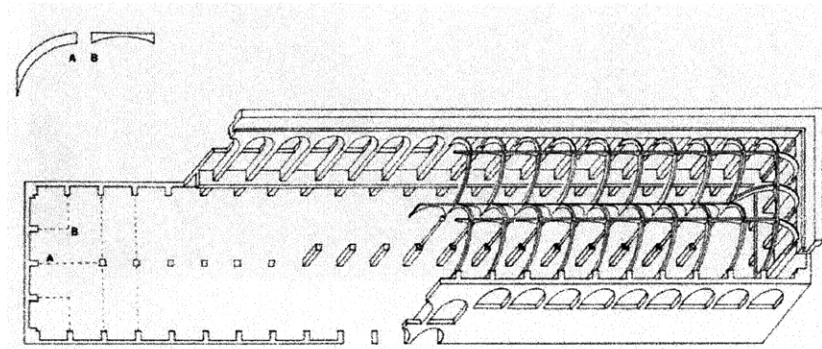

Henri Labrouste, *Bibliothèque Ste. Geneviève*, axonometric showing iron ribs within masonry shell

26 |

While Semper would not write of the relationship between the tectonic and stereotomic until the 1950's, there was a clear comprehension of its potential well before that. In his 1854 design for the reading room of the Bibliothèque Nationale in Paris, Henri Labrouste embarked on a project that would insert a new, fireproof iron framework into the existing masonry shell of the library. Like his previous project for the Bibliothèque Ste. Geneviève, Labrouste shifted away from the traditional masonry vaulting in favor of slender iron columns that supported a lattice of wrought iron arches, covered with terra-cotta panels and glassed cupolas. This lightweight velarium-like system allowed for an airy, top-lit space that recalled the weightlessness of a tented structure, especially when contrasted with the enclosing masonry shell. This contrasting relationship was not only expressed in the roof. It is also found throughout the building in

its cast iron beams, rails and fittings, as well as iron tie rods that ran from the steel arches through the masonry shell to metal plates on the exterior.

Perhaps inspired by Labrouste's Bibliothèque Nationale, Auguste Perret created his Théâtre des Arts Décoratif of 1925 with a similar top-lit lightweight steel roof. Because this was a temporary structure, wood columns and a lightweight concrete beam system replaced the masonry shell of the Bibliothèque. A steel grid of trusses spanned delicately across the roof, and 150 linen screens filled both the clerestories and the latticework of the ceiling, allowing translucent light to permeate through the theater.

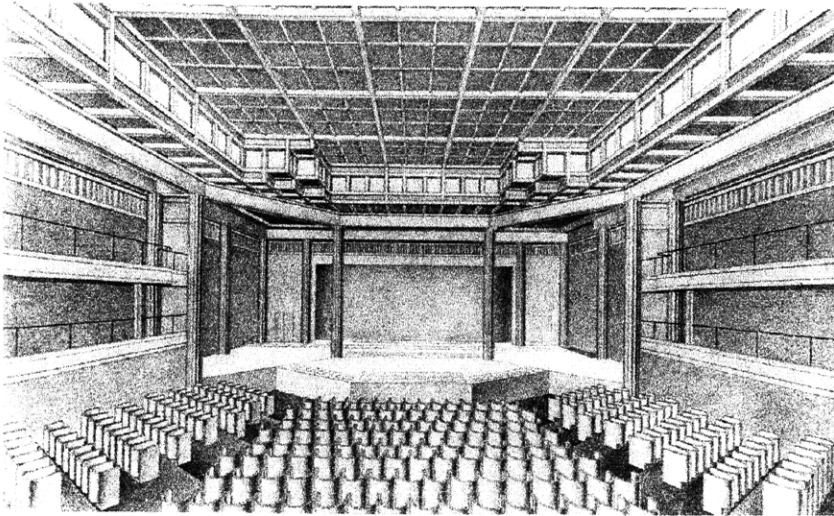

*Auguste Perret, Théâtre de L'Exposition des Arts Décoratifs,
Perspective*

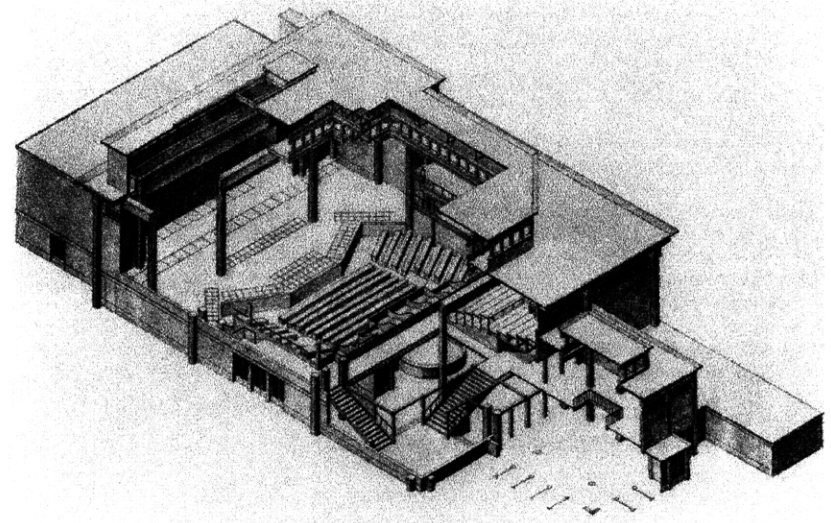

*Théâtre de L'Exposition des Arts Décoratifs
Axonometric*

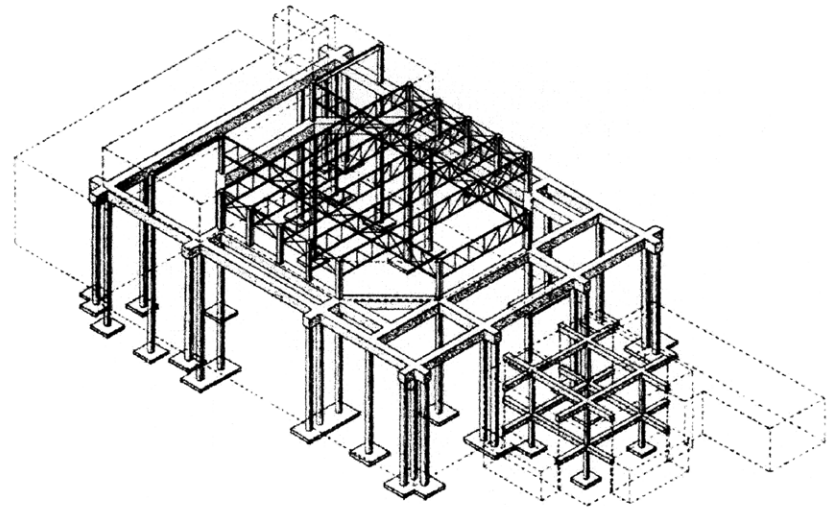

*Théâtre de L'Exposition des Arts Décoratifs
Axonometric showing metal trussed roof and concrete beams*

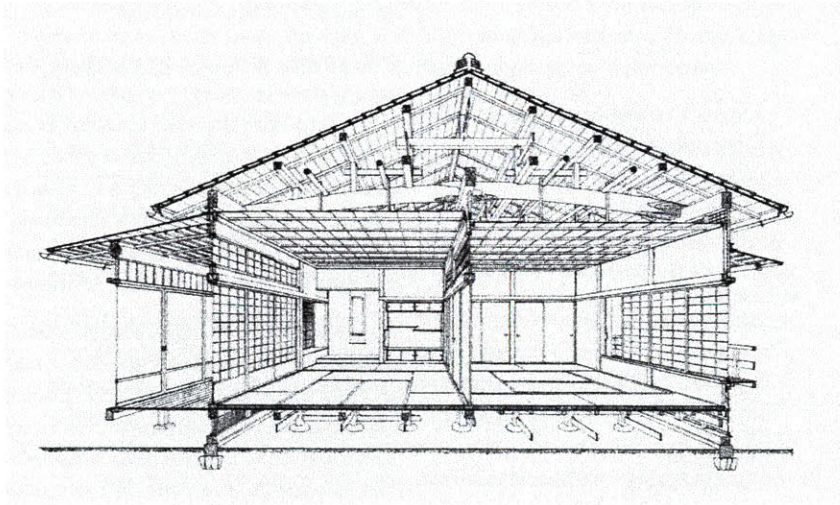

Traditional Japanese one-story house



Pyramid of the Moon, Teotihuacán City

28 |

Jorn Utzon understood the impact that perceptible and tactile forms could have on the subject. In his essay "Platforms and Plateaus: The Ideas of a Danish Architect,"⁵ Utzon describes the act of moving through architecture as experiential, rather than visual:

"The floor in a traditional Japanese house is a delicate bridge-like platform. This Japanese platform is like a table top. It is a piece of furniture. The floor here attracts you as the wall does in a European House. You want to sit close to the wall in a European house, and here in Japan, you want to sit on the floor and not walk on it. Contrary to the Mexican rock-like feeling of the plateau, here you have a feeling similar to the one you have when standing on a small wooden bridge, dimensioned just to take your weight and nothing more."

Here Utzon recognizes the cross cultural distinction between the light and heavy, as it relates to experience of moving through space. Some cultures tend to embrace the tectonic, while others embrace the stereotomic; for example the traditional Japanese house and the Mayan pyramids of Mesoamerica respectively. In many cultures, one can find both the tectonic and the stereotomic in opposition to each other. For example, as Utzon shows in his sketch of a typical Chinese temple, a lightweight timber roof often floats above a heavy masonry podium. This juxtaposition can be found in many of Utzon's works, from his small patio houses to the Sydney Opera house, where a lightweight folded structures are suspended above terraced earthworks.

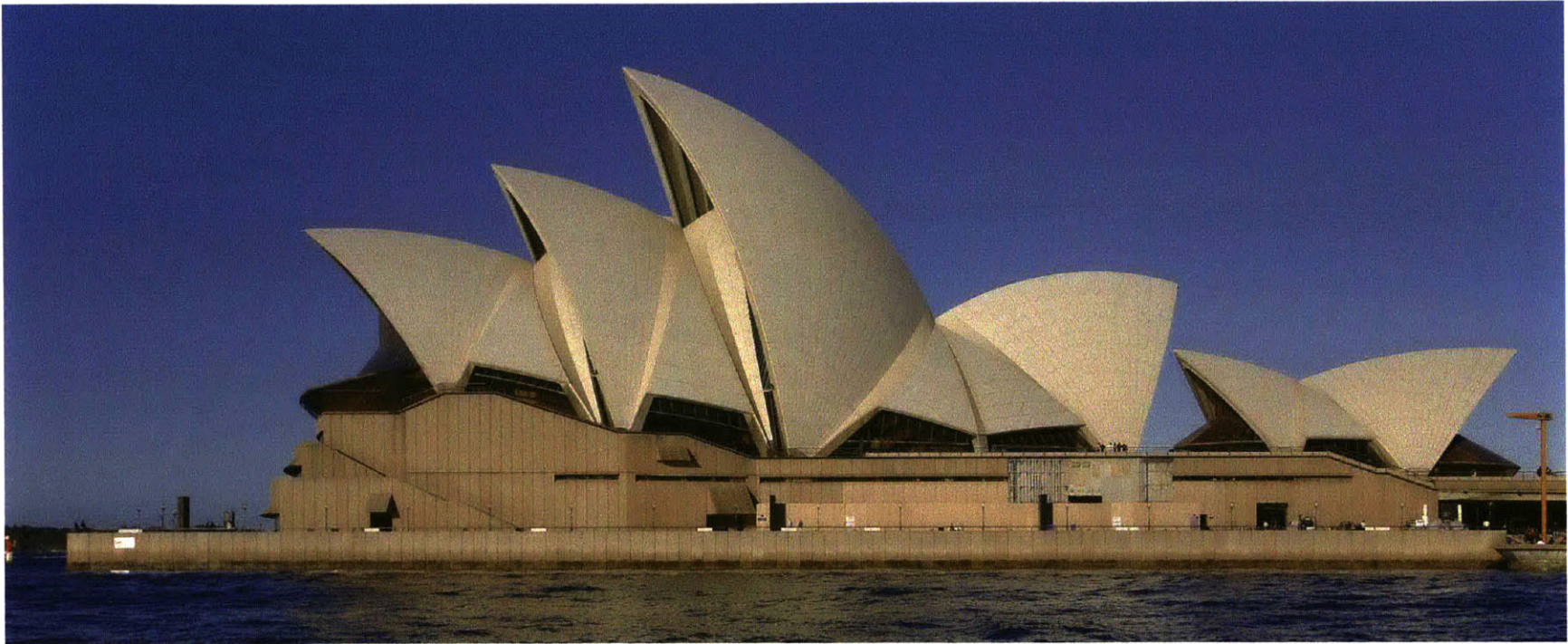

Sydney Opera house, Jorn Utzon

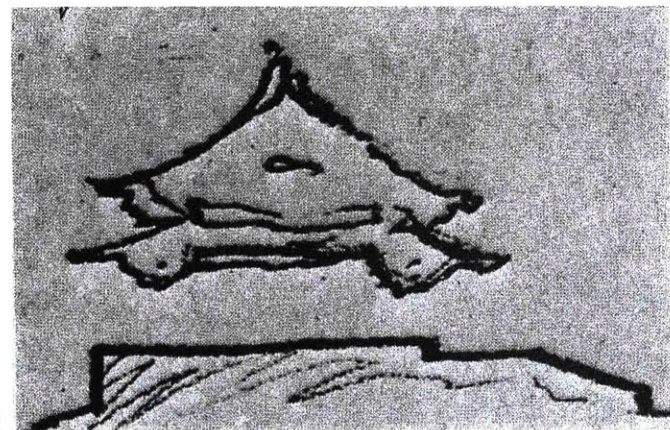

sketch of a Chinese temple, Jorn Utzon

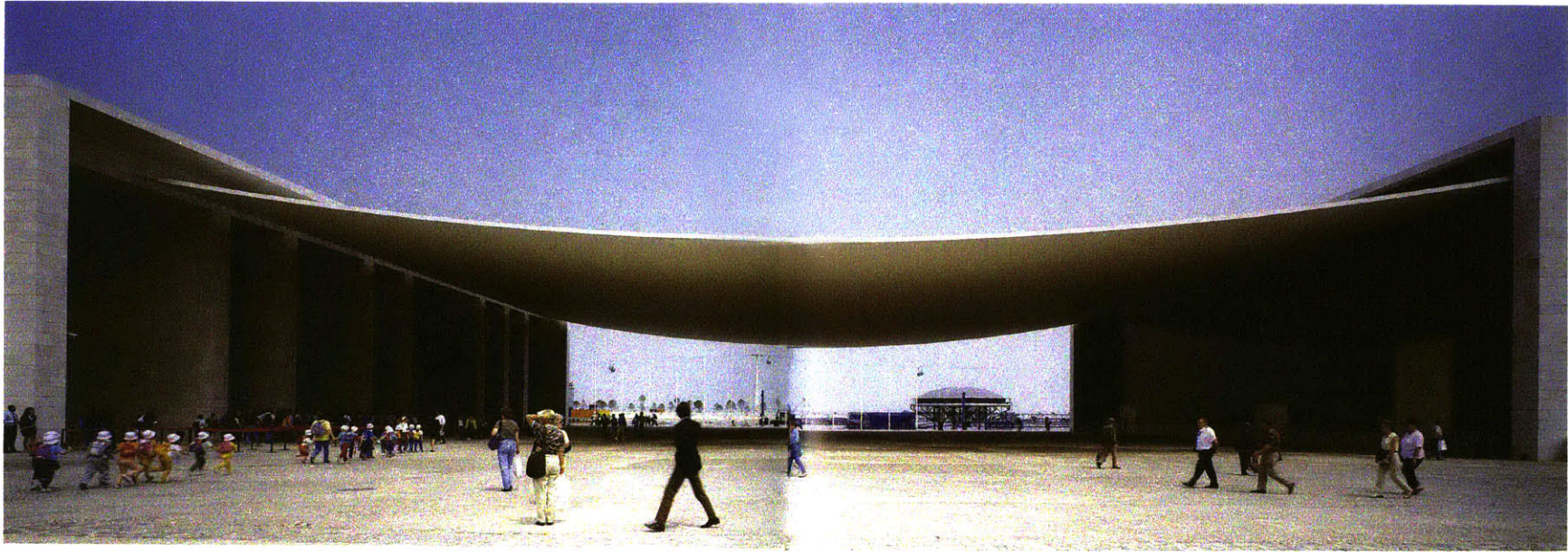

*Portuguese Pavilion at the '98 Expo in Lisbon,
Alvaro Siza*

30 |

Alvaro Siza provides a modern interpretation of this tension between the light and heavy with his Portuguese Pavilion in the Expo '98 in Lisbon Portugal. A thin, concrete veil is suspended by steel cables between two large stone masses, juxtaposing the light shell with the weight of the anchoring programmatic buildings. As a variant of the podium and floating roof relationship described by Utzon, this form stretches a taut, floating roof between two massive stereotomic forms. Furthermore, Siza's use of reinforced concrete as the "floating" form reveals the multiple tectonic uses of materials.



Portuguese Pavilion details showing reinforced concrete shell roof



*photographs from the Beichuan School
taken 5/11/2008, 24 hours before the earthquake*

SCHOOL TYPOLOGIES

32 |

This project serves as an opportunity to rebuilt trust in the Chinese educational system. The government estimates that upwards of seven thousand school buildings failed during the earthquake, and has acknowledged that sub-standard construction has been to blame for much of the failure. In rebuilding a school following an earthquake, we must ask what the psychological implications of returning to a similar school might be. While a new campus and school building may be an opportunity to restore faith in the school system and restore a lost identity, it also has the potential to invoke fear and mistrust.

Many of the collapsed schools were constructed using precast concrete panels, but lacked proper reinforcement and connection details. Poorly graded aggregate and insufficient cement mixtures

contributed to concrete failure. When the earthquake hit, columns buckled, and panels came loose and fell, rather than deforming in place.

Much of the failure was due to negligence during construction, rather than during the design phase. Controlling the quality of construction in the new school is of utmost importance. However, shifting away from old design typologies can also allow the students and community to restore their faith in the schools and experience a fresh beginning.



Beichuan School rubble, showing poorly graded aggregate in concrete

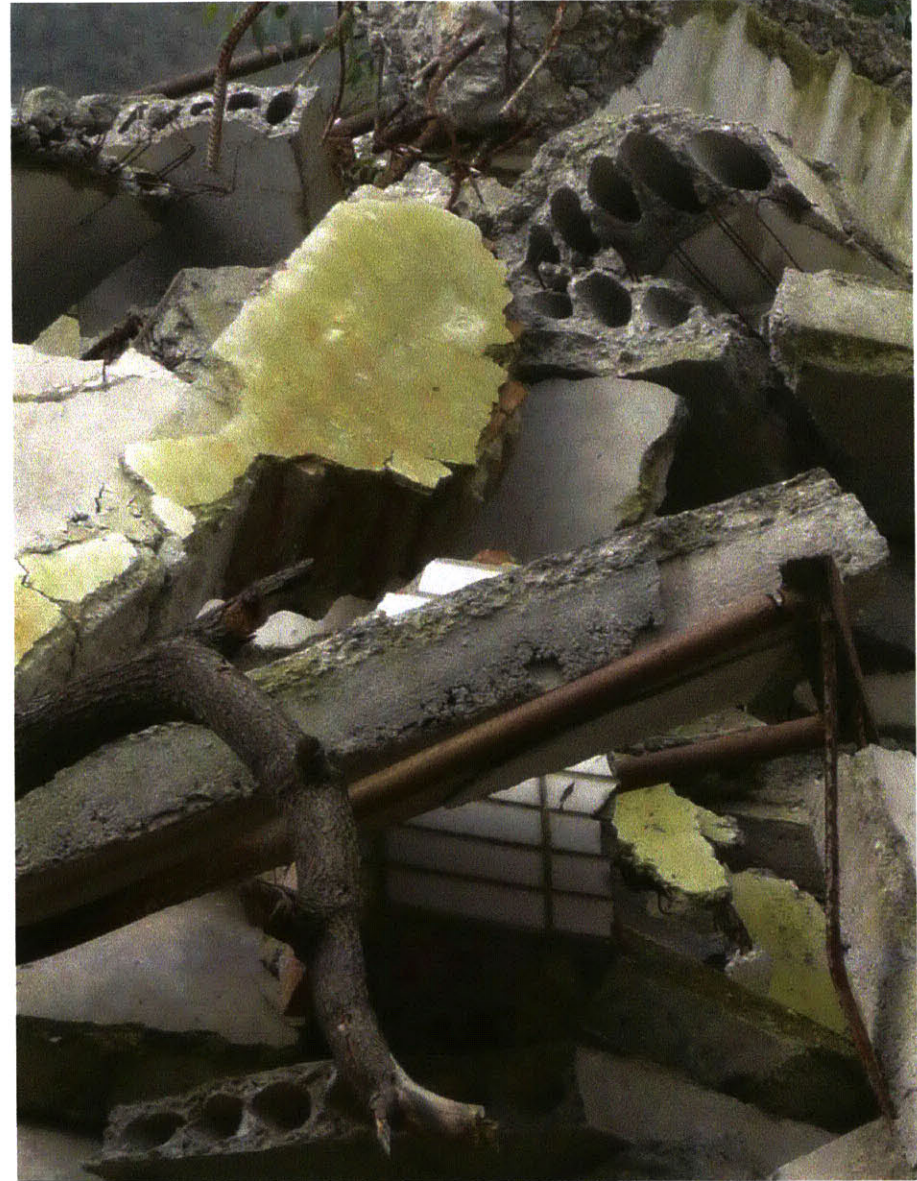

Beichuan School rubble, showing precast slab construction



Temporary school classrooms in Mianyang



Temporary school dorms in Mianyang

TEMPORARY SCHOOLS

- 34| In the town of Mianyang, just south of Beichuan, a television manufacturing company has donated their training facility as a temporary school site for middle and high school students from Beichuan county. The existing training facilities function as makeshift classrooms, and single story, lightweight barracks have been erected for dorms, with up to 12 students per room. During lunch, students return to their dorm rooms to eat and socialize, as the temporary campus lacks proper cafeteria and communal spaces. In Chengdu, Shigeru Ban has designed a temporary elementary school for students from Sichuan province. Using a simple cardboard tube structure sheathed with plywood and corrugated plastic, Ban has developed a simple yet elegant construction process that allows for natural lit spaces with a unique character.



Shigeru Ban's temporary cardboard tube school in Chengdu



*typical classroom
Yihai Gardens, middle school, Beijing*

EXISTING SCHOOLS

36 |

Chinese education is centered primarily around the classroom. Unlike the American system where students change classrooms for different subjects, Chinese students generally remain in the same classroom throughout the day, with the exception of science labs and music class. Lab rooms often have adjacent prep-rooms, but classrooms are typically square rooms connected by a single or double loaded corridor. Boarding schools are common, as many students' families live far away, especially in rural areas.

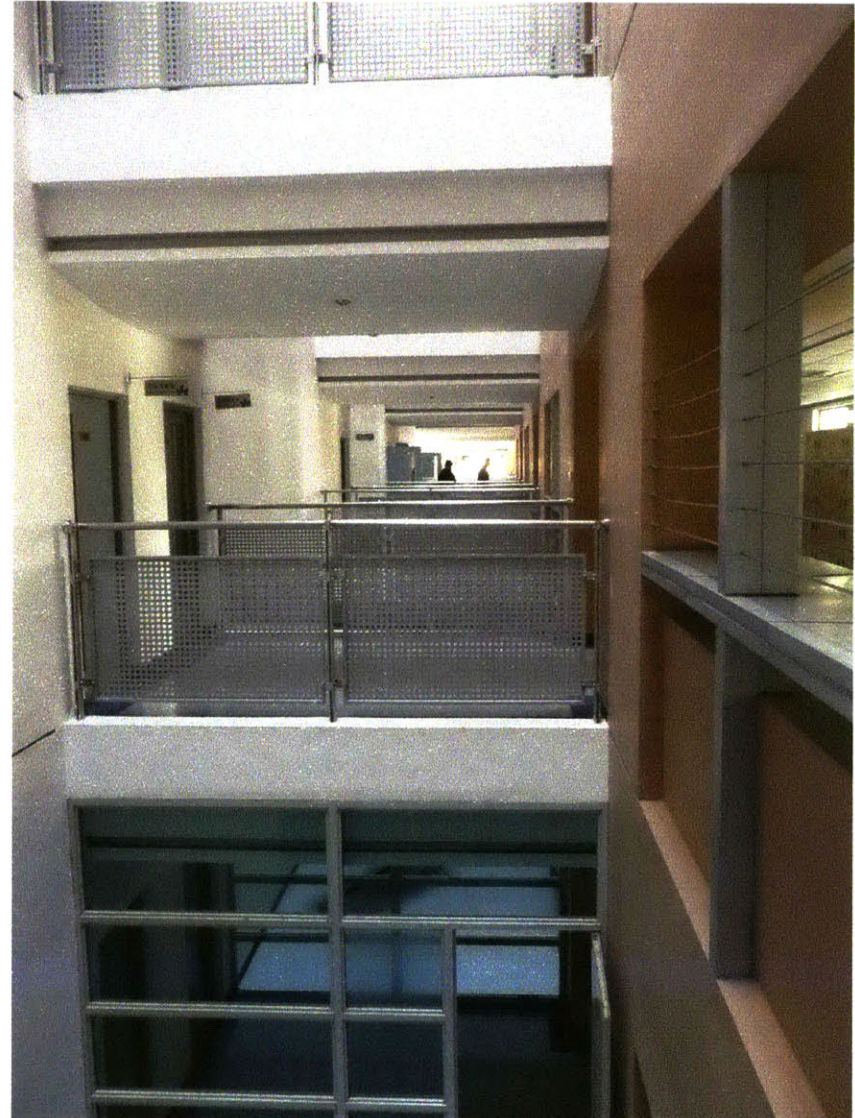

*hallway atrium / light well
Yihai Gardens, middle school, Beijing*

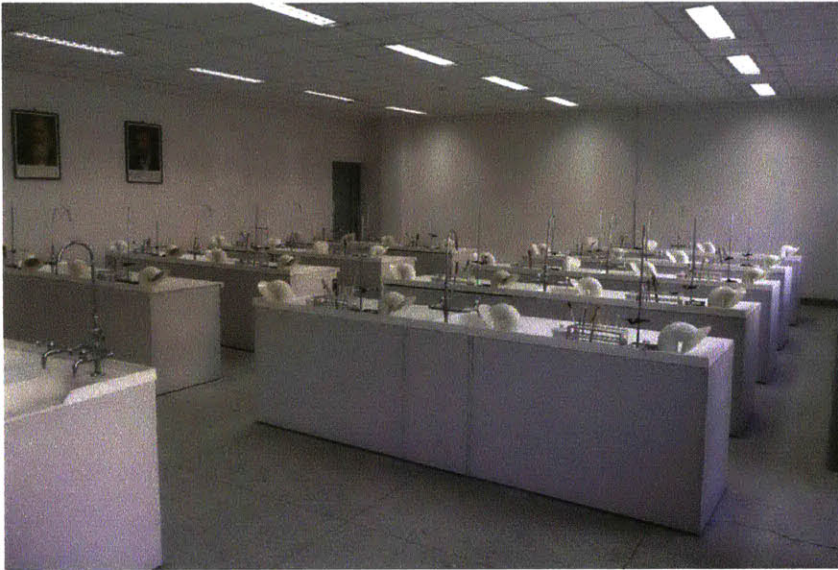

typical science laboratory



prep room adjacent to laboratory



occupied dorm room



dining hall



covered walkway, showing partially embedded wood columns and beams

TRADITIONAL CONSTRUCTION

38 |

Traditional Qiang minority buildings in Sichuan Province are constructed primarily with a palette of locally available material: stone, earth and timber. In these historic villages, where protection from invaders was of utmost importance, buildings were designed with defense in mind. Constructed with thick stone and earth masonry walls, these low, squat forms, which often included watch towers, were usually in square or hexagonal forms. Walls were traditionally wider at the bottom to provide added fortification and stability. Timber was embedded within the walls as lintels and beams.

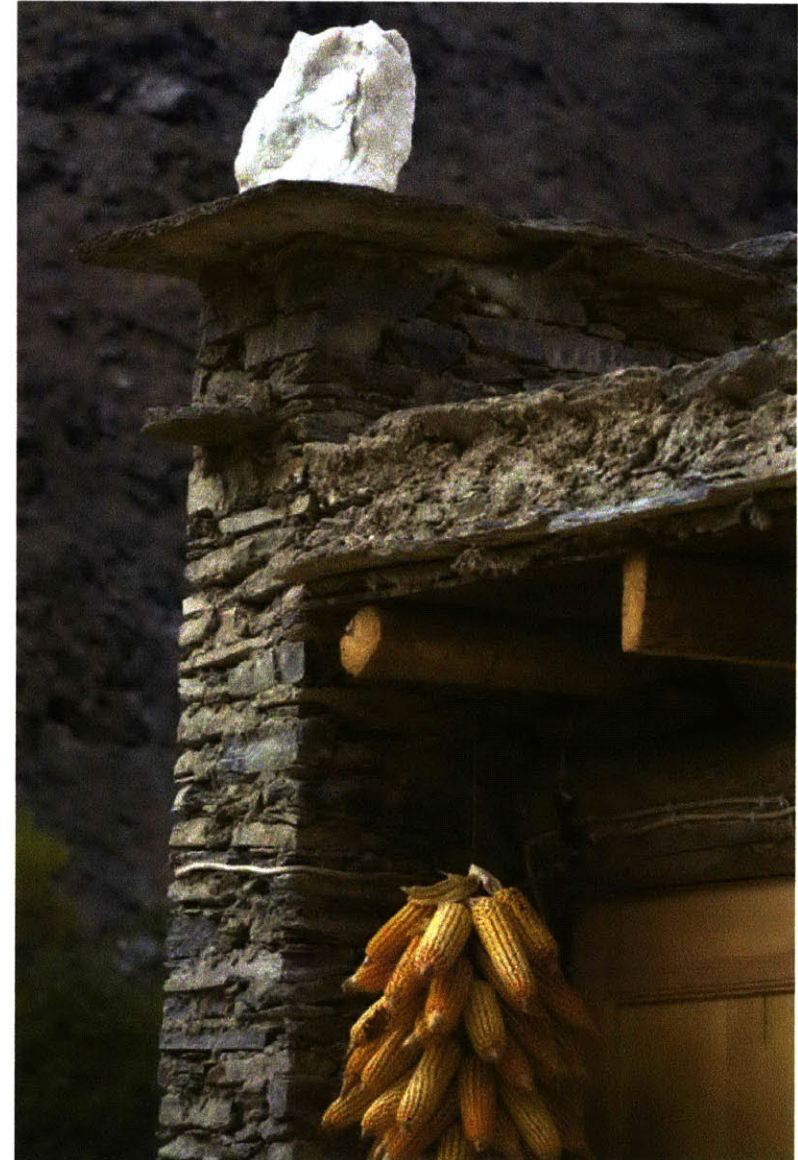

typical Qiang construction detail, showing rammed earth and stone construction, and wood lintels/beams



*typical Qiang construction in Taoping Village with heavy, tapered walls,
and attached wood balconies*



red clay fired brick



typical lightweight roofing material

LOCAL CONSTRUCTION MATERIALS

40 |

Present day construction methods in Sichuan Province are predominantly brick and concrete. Despite taxes levied by the government on clay bricks due to their negative environmental impacts, they remain the least expensive form of construction, and are widely used throughout the region. Both cast-in-place and pre-cast concrete construction are commonly used, often with brick infill. Timber and steel framed buildings are rare. A panel system consisting of foam sheeting sandwiched between two thin steel sheets is often used as an inexpensive roofing material, especially in rural residential construction.



due to its low cost, brick construction is extremely common in Sichuan Province



brick walls will be used as formwork for concrete columns

LOCAL CONSTRUCTION PRACTICES

42 |

Visits to construction sites in Beichuan county revealed local construction practices and techniques, as well as contemporary interpretations of Qiang minority building typologies. In this recent development, approximately 40 townhouse homes were being constructed using brick and reinforced, cast-in-place concrete. In a reversal of the usual practice of pouring concrete columns and slabs using formwork and then infilling with brick, here the brickwork was done first and served as formwork. Thick, tapered brick walls were built upwards, leaving gaps where columns would be placed. Rebar was placed into the column gaps, and concrete was poured. With the exception of the upper level, where the columns became exposed due to the taper in the walls, minimal amounts of formwork were needed.



cast-in place column and precast-lintel



Beichuan county housing project under construction



cast in place floor slab



brick walls are clad with stone tile

44 |

Once wall and column construction is complete, roof and floor slabs are built of reinforced concrete. In the completed "model home," the exterior walls were clad with stone tile, perhaps a tribute to the traditional stone and earth construction of Qiang minority buildings. While these construction methods take advantage of local bricklaying skills and available materials, its design seems ill-suited for a wet, humid climate. Overhangs are small, leaving little sheltered outdoor space, and small window openings result in poorly lit and ventilated interior spaces.



completed "model" home



wheat branches, cement and recycled aggregate form the basic ingredients of the "rebirth brick"



a common brick-pressing machine uses human power and leverage to create bricks

LOCAL ARCHITECTS

46 |

The role of an architect is one of negotiation between clients, budgets, sites and many other conditions and constraints. Two architects who have located their practices in Sichuan province have been particularly adept at using locally available resources and skills in innovative and strategic ways.

Based in Chengdu, Liu Jiakun of Jiakun Architects has built his practice around this negotiation between resources and needs. In his Rebirth Brick project, he has developed a manufacturing process for reconstruction in earthquake stricken zones. Construction debris from the earthquake is collected, cleaned and recycled to be used as aggregate. Wheat branches, which are abundant in the region, are used as reinforcing fibers, and also serve to reduce weight. Bricks are created using a semi-manual press that is commonly used in the

region. The result is a lightweight brick that can be created on site using existing technology, but with lower embodied energy than a typical clay-fired brick. It also serves as a metaphorically "reborn" construction practice, shifting from a situation of turmoil and destruction to one of rebuilding and "rebirth."

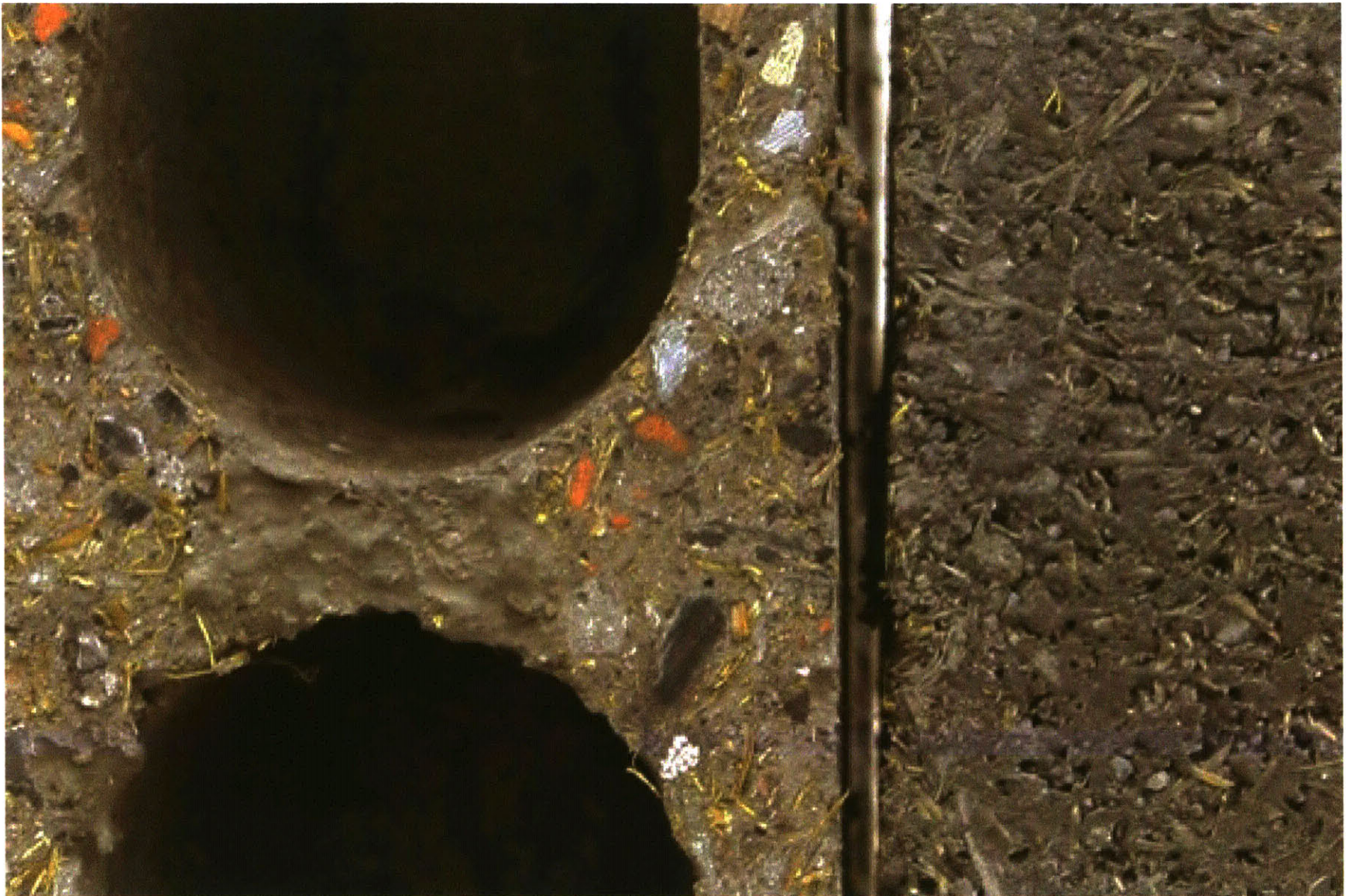

samples of the "rebirth brick"



brick being used as formwork during construction of the Luyeyuan Museum



entrance to Luyeyuan Museum

48 | In the Luyeyuan Stone Sculpture Museum in Sichuan Province, Liu Jiakun adapted construction methods to take advantage of local conditions. His design called for fair-faced concrete, but local workers could not be relied upon to erect plumb formwork. Instead, Jiakun used the bricklaying skills of the workers to his advantage: brick walls served as both the supporting structure for the formwork, as well as one side of the form itself. The brick walls were left inside the concrete faces, which functioned as an insulating cavity wall layer within the concrete wall, negating the need for any foam insulation.



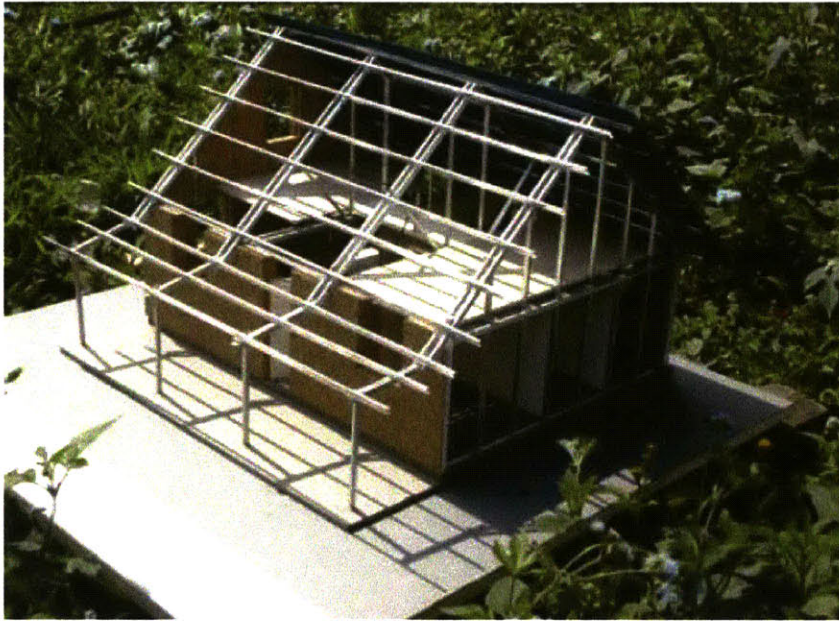

model



lightweight steel bents being erected

50 |

With his firm, Atelier-3, Hsieh Ying-Chun works with rural communities to create sustainable housing in low-income areas. While his projects are based on vernacular forms and draw from their ecological principles, they also incorporate modern industrial building materials. Hsieh has developed a simplified lightweight steel framing system that is easily constructed by unskilled laborers using bolted connections, and uses locally available materials for infill. It was conceived as an open system that is easy to repair and replace, and has the adaptability to adjust to various building applications. With steel's inherent strength and flexibility, the system allows for robust structures in seismic zones, with minimal environmental impact. Lateral support comes from bracing and shear walls, while infill can vary depending on locally available materials and climatic conditions. Various projects have used wood, straw, mud, stone and

bamboo, and often combine multiple materials. While the building industry is typically differentiated and highly professional, this system allows for self-sufficient construction with reduced material transportation costs and market dependence. As Hsieh notes, this promotes community engagement and solidarity while simultaneously constructing well-built and environmentally friendly homes.



workers securing roof purlins



workers apply sheathing over a simple, bolted steel roof



lightweight steel framed home with infill of stone, brick, bamboo and plywood

SYSTEM

TECTONIC SYSTEM

This thesis aims to create a tectonic system that can be implemented throughout the project. This toolkit of parts, that ranges from the stereotomic masses of rammed earth and masonry, to lightweight floating roofs and walkways, allows for the creation of identity through materiality. Building forms throughout the school may vary, but are held together cohesively through the application of similar construction techniques.

This system has been developed to achieve excellent climatic performance, while minimizing resource use and impacts. All materials are used locally, minimizing transportation costs, and can take advantage of a surplus of labor.



paving stones



brick



light steel framing



rammed earth



glass



concrete

material palette

CONCRETE FRAME AND INFILL

Building cores are constructed using a simple cast-in-place concrete frame, and slab construction. With proper reinforcement and aggregate mixtures, a robust structure can be developed that will deform, rather than fail in the event of an earthquake. Each core is structurally autonomous and isolated from the next. This ensures that they are structurally sound regardless of whether they stand alone or are linked to others.

Wall infill is a standard brick and concrete masonry unit cavity wall construction, providing a natural thermal break without the use of foam insulation materials. Wood paneling is also used as infill, with operable windows and vents to ensure cross ventilation.

Clay-fired brick is common in the region, although the government has placed a tax on the use of these bricks due to the negative environmental impact caused by their production. However, despite this tax, the use of clay-brick remains commonplace, as it is still one of the least expensive building materials available in the region. Because the infill is not load bearing, it may be possible to use cast-on-site bricks such as Jiakun Architect's "rebirth brick." While labor intensive, these bricks do not require any excavation or firing, and will minimize transportation costs as they can be made on site.

cast in place concrete frame

cavity wall construction with brick and cmu units

concrete floor slabs

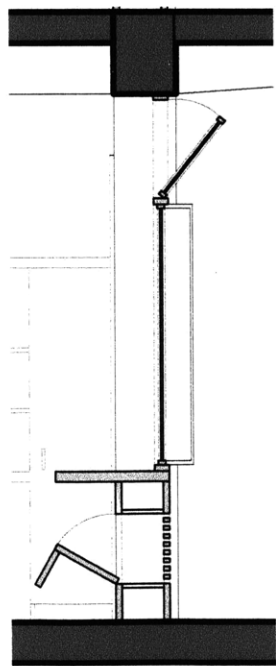

typical sectional detail of infill panel, showing operable windows and vents

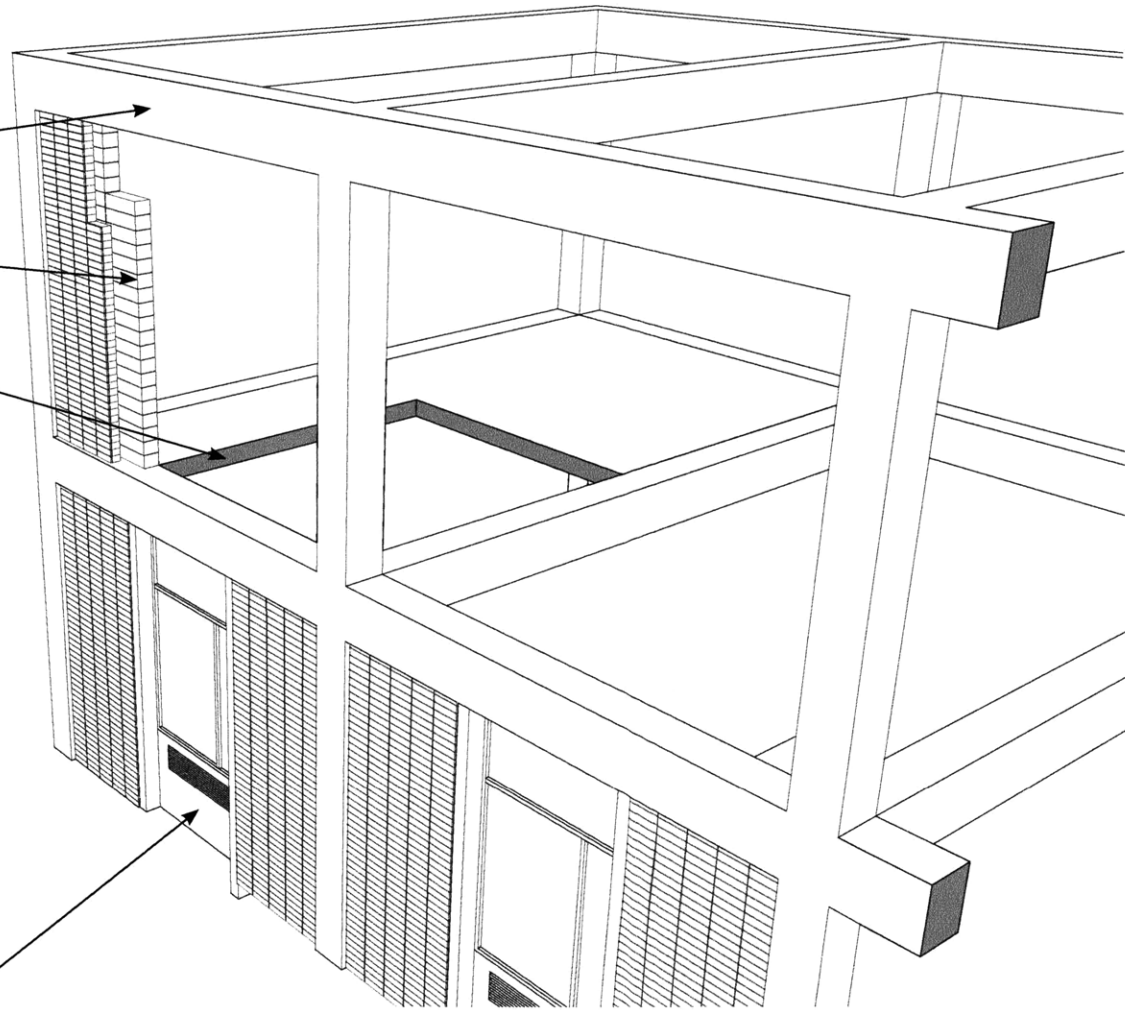

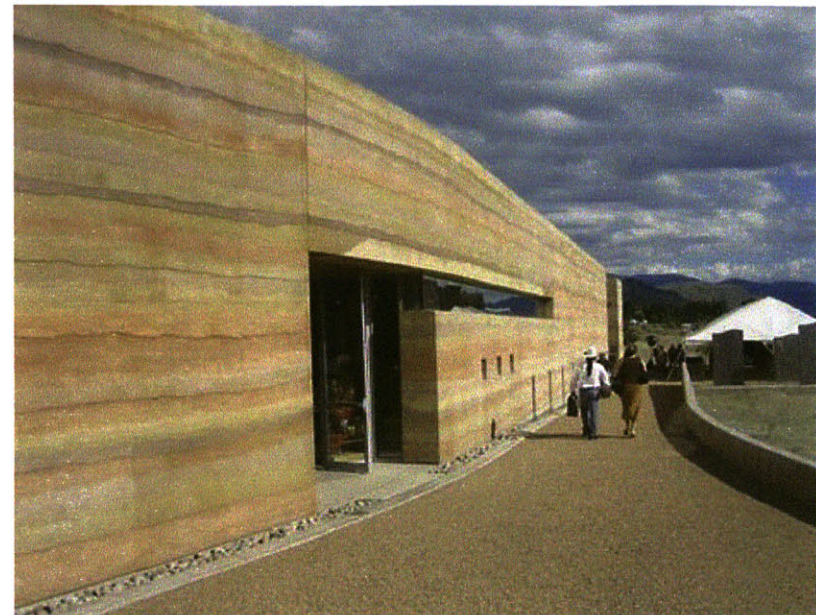
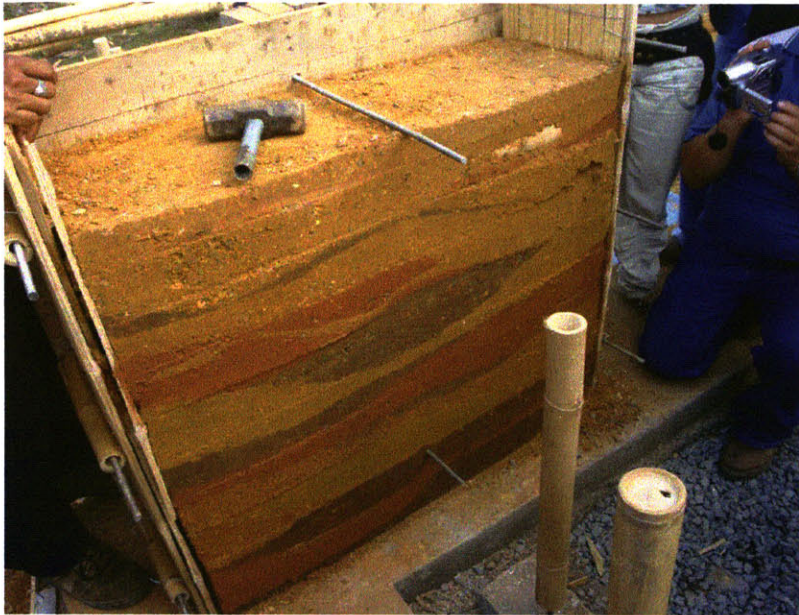

RAMMED EARTH CONSTRUCTION

58 |

Rammed earth construction has been used in China for centuries, and ancient rammed earth buildings often last longer than their timber framed counterparts, due in part to their fire resistance. This system proposes the use of 60cm thick rammed earth walls, resting upon an elevated concrete foundation with a moisture barrier to reduce moisture uptake from the earth.

While rammed earth can act as a load bearing structure, Chinese building code prevents it from being used structurally. For this reason, steel I-beams are partially embedded into the earthen wall, in a manner similar to the wood columns of traditional Qiang construction. Steel "I" beams rest on these columns, and support a flat roof hidden behind the earthen parapet. Like the brick formwork

in the Luyeyuan museum, the embedded columns and rammed earth wall have a symbiotic relationship; the columns are used to support the rammed earth formwork during construction, while the earth walls in turn provide lateral bracing and also serve as partial fireproofing of the steel frame.

Window and door openings are created using upturned steel "T"-beams as lintels. The wall is capped with a steel plate, with overhangs and drip edges to prevent rain from running down the wall.

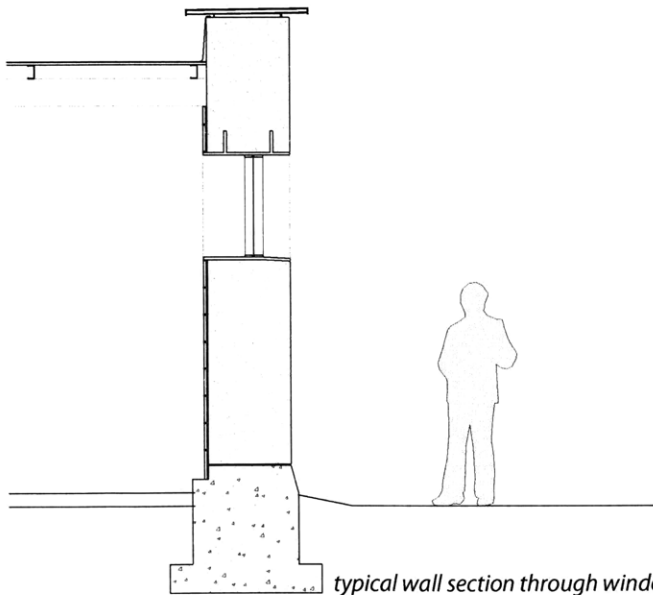

typical wall section through window, with embedded steel "T" beams as lintels. angled footing and sloped ground allow water to splash away from wall during rainstorms

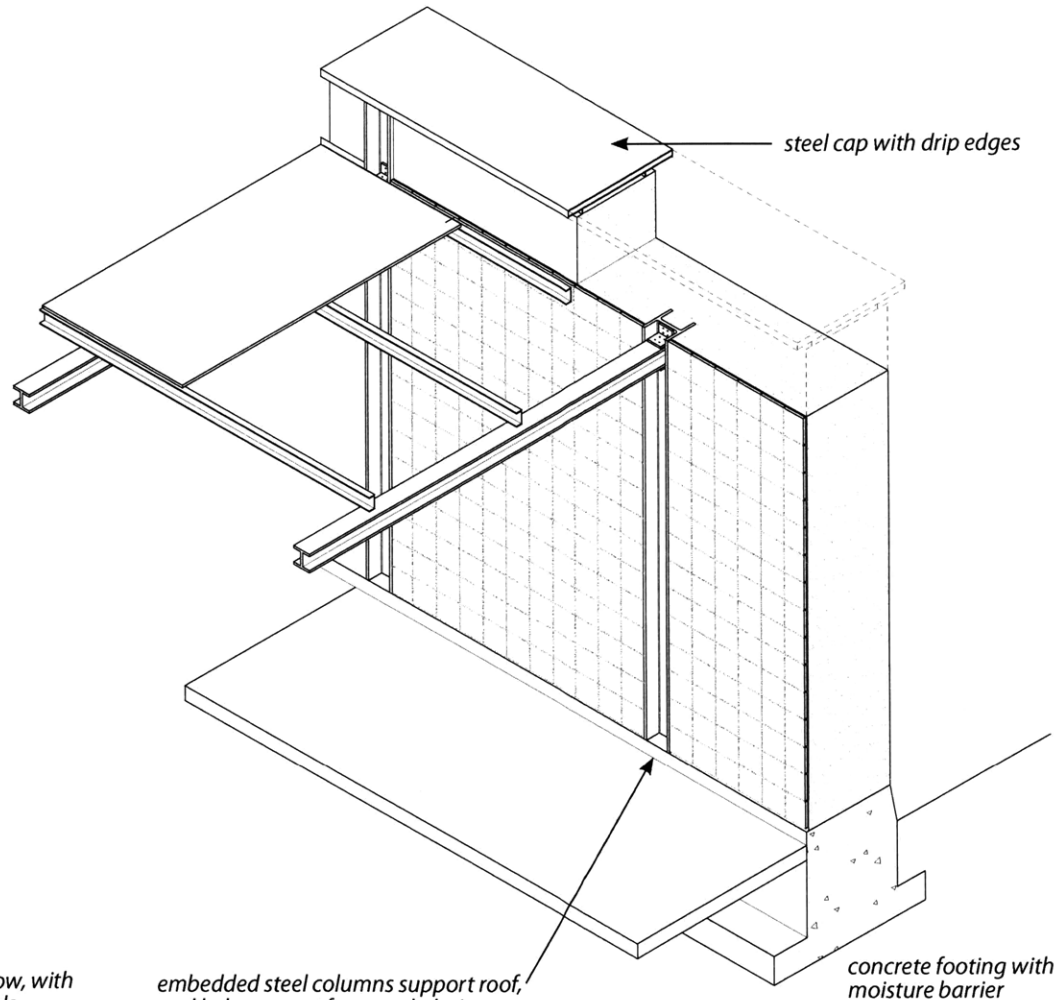

embedded steel columns support roof, and help support formwork during rammed earth wall construction

steel cap with drip edges

concrete footing with moisture barrier



house by Hsieh Ying-Chun using lightweight steel exterior walkway system

LIGHTWEIGHT STEEL CONSTRUCTION

60 |

A light weight steel framed walkway system wraps around the southern facade of the building clusters. It is supported by independent footings, and attaches to the main building using brackets that mount directly onto the concrete beams. This system functions as the primary circulation between clusters, as well as a shading system for south-facing exterior windows. On the east and west facades of the clusters, the walkways widen and function as outdoor gathering places for students.

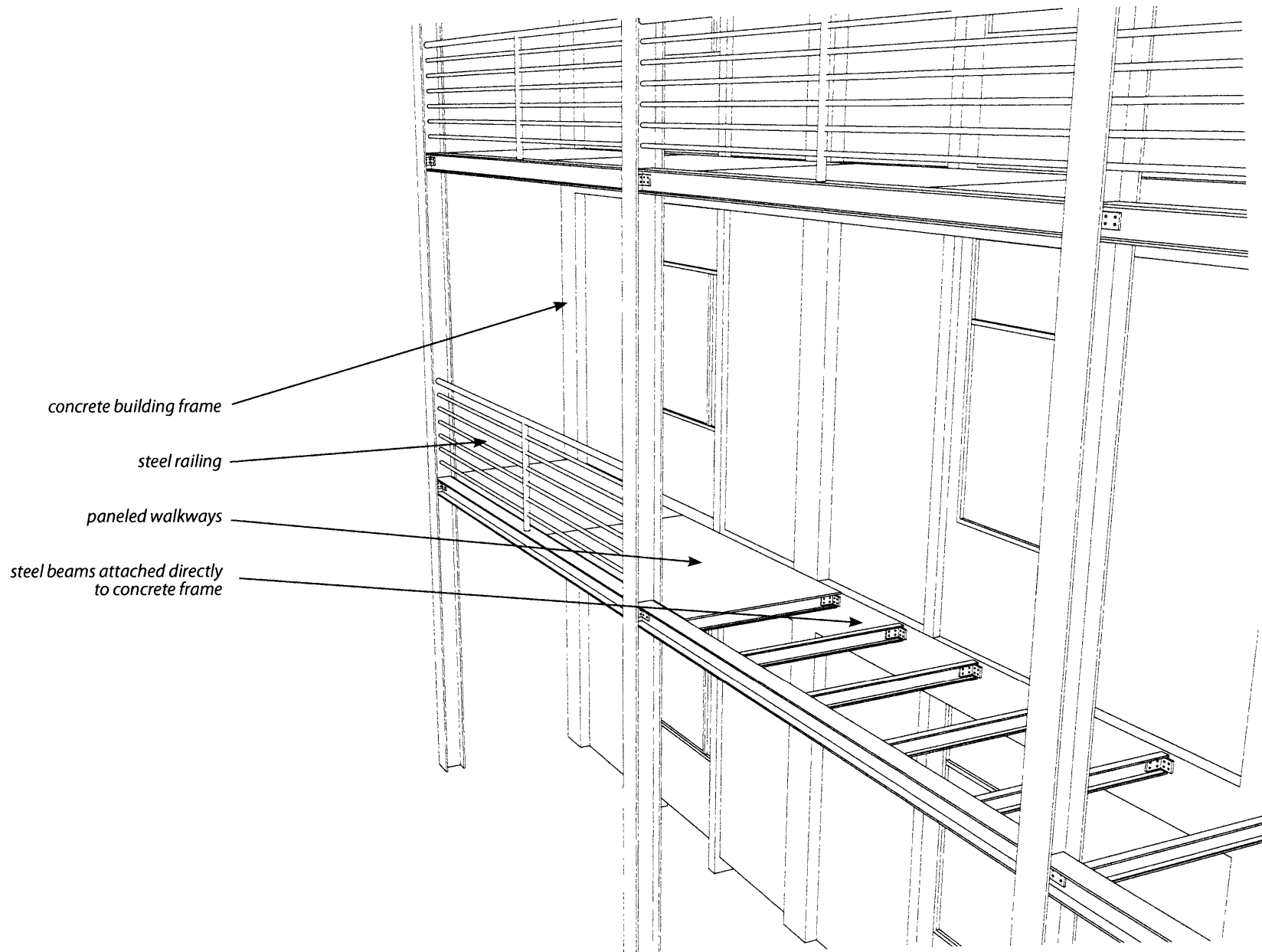

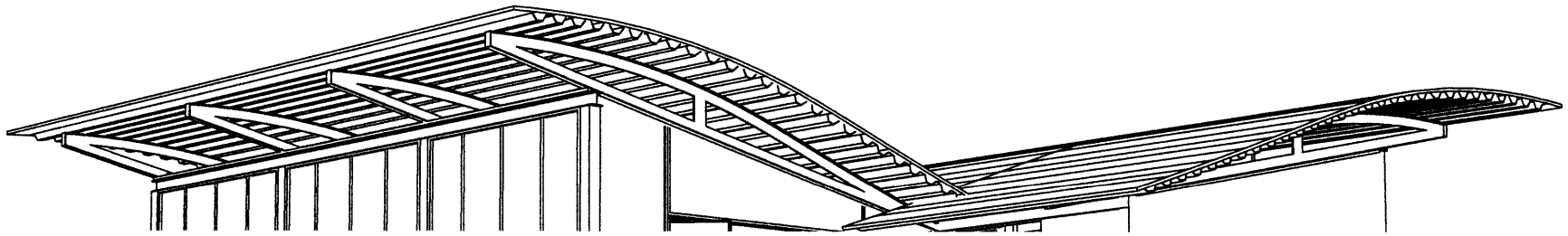

LIGHTWEIGHT ROOF CONSTRUCTION | CURVED

62| The lightweight metal roof system consists of three layers: Curved steel trusses form the basis of the roof, allowing for both concave or convex forms. The trusses rest on the structure below, and are cross braced to prevent racking. Corrugated steel wraps over the trusses, providing structural sheathing for the roof. The orientation of the corrugation allows for curvature within the sheet, while the depth of the corrugation allows the overhangs to extend beyond the supporting trusses, providing protection from the rain. The roof is capped with thin metal sheathing, and a water proofing membrane. On “U”-shaped members, gutters are formed as an integral part of the truss, with a gap in the top layers of the roof.

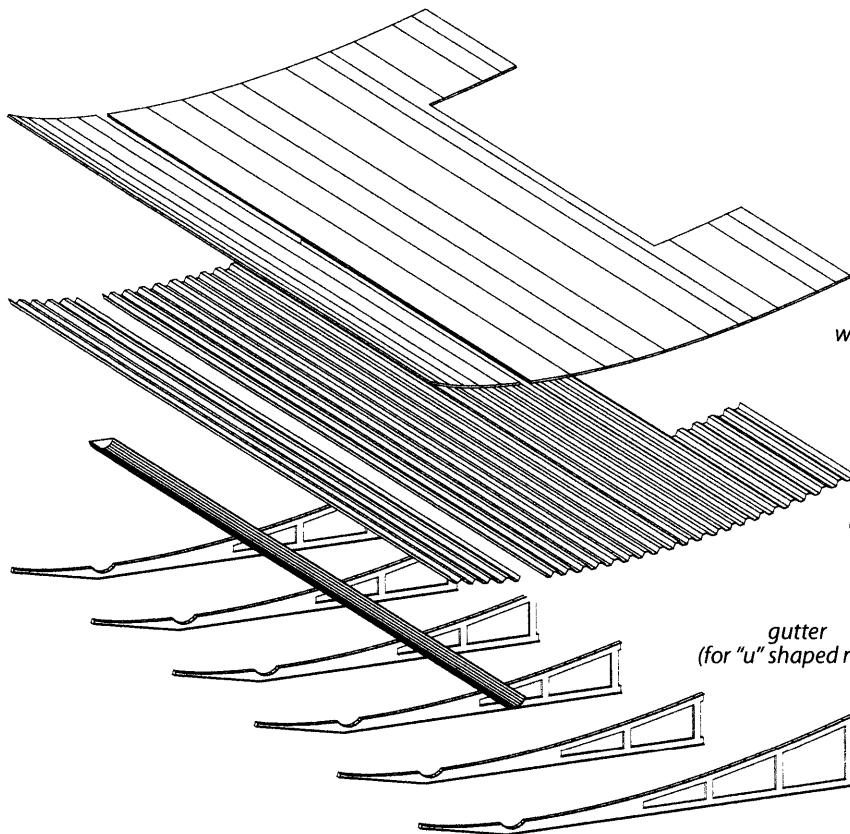

roofing material /
waterproofing membrane

corrugated sheet metal

gutter
(for "u" shaped roofs)

curved steel trusses

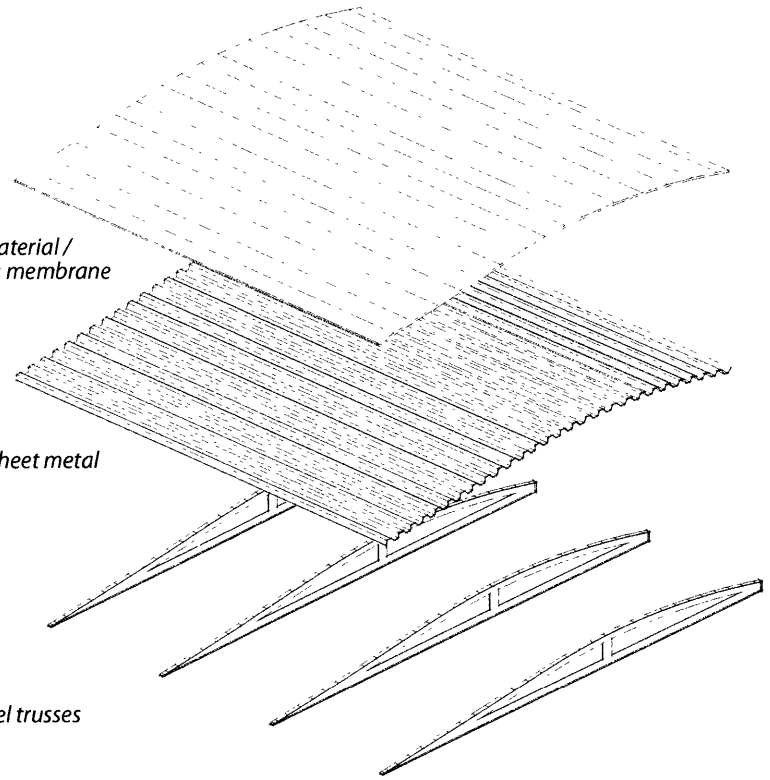

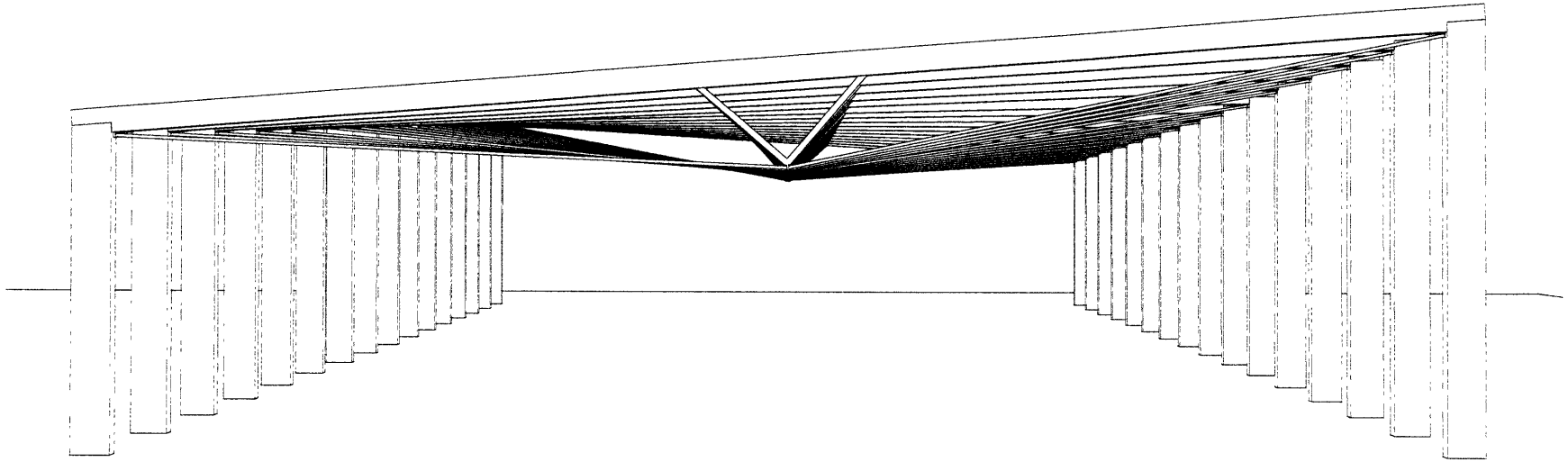

LIGHTWEIGHT ROOF CONSTRUCTION | ROTATING

64 |

The double curvature of the roof is achieved through the repetition and rotation of a simple truss upon its center axis. These prefabricated glulam and steel trusses rest on glulam columns of incrementally increasing and decreasing heights. Based upon the unit of a single sheet of plywood, the trusses are spaced at 2.4m on center. Small steel purlins span between the trusses at 1.2m intervals, and the entire roof is sheathed with staggered sheets of plywood. The inherent flexibility of a single sheet of plywood allows each individual sheet to adjust within its limits to the roof's double curvature. When aggregated together, they create a rigid, twisting plane. Lateral bracing is achieved through tension rods between columns, and the rigid sheathing of the roof also prevents shear.

flexible waterproofing membrane ensures a waterproof roof

staggered sheets of 2.4m x 1.2m plywood adjust to the roofs curvature

lightweight "c" channel purlins spaced at 1.2m

glulam beams, with metal rods and steel cable form rotating trusses

columns of incrementally increasing / decreasing height are spaced at 2.4 m

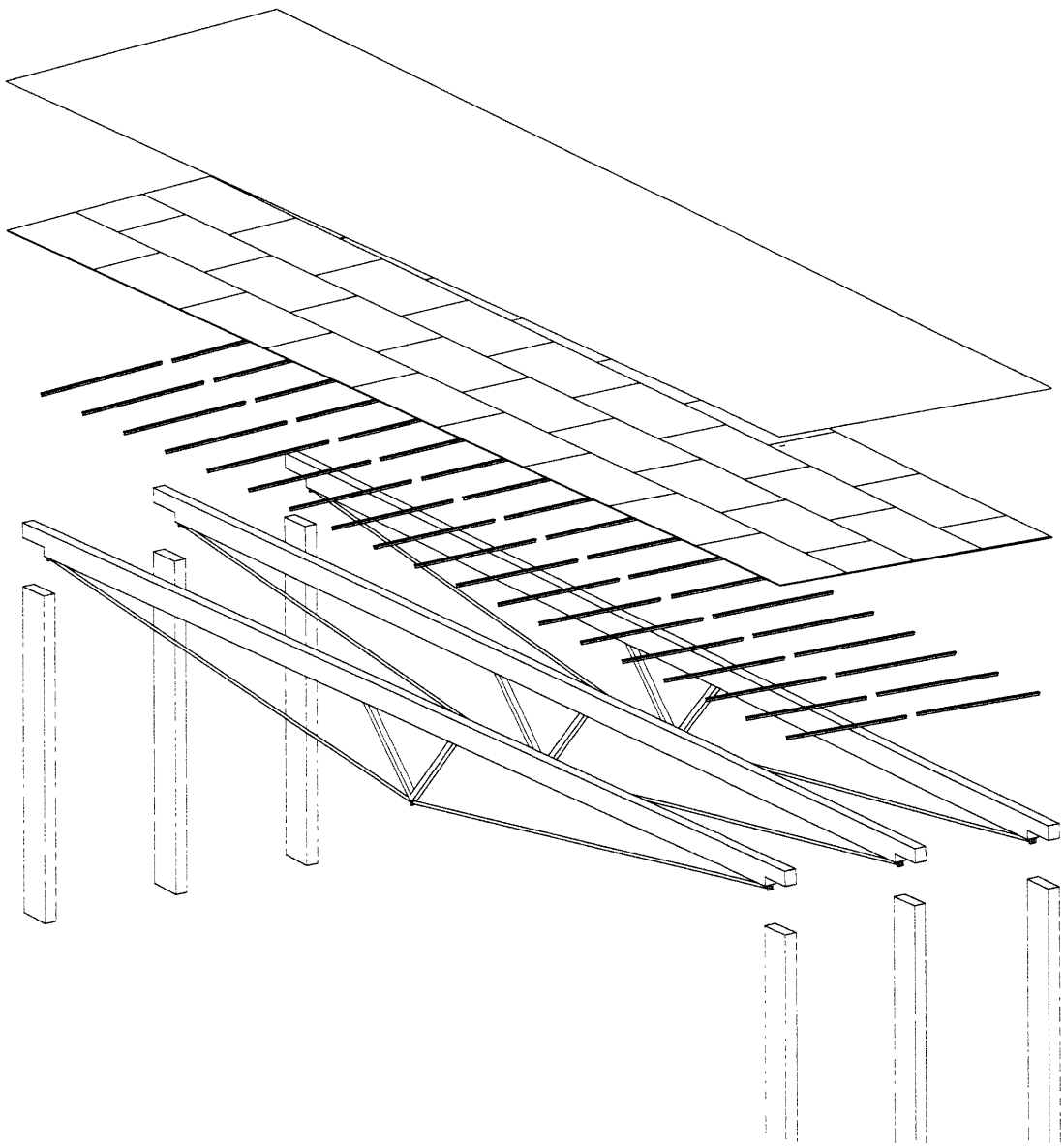

PROJECT

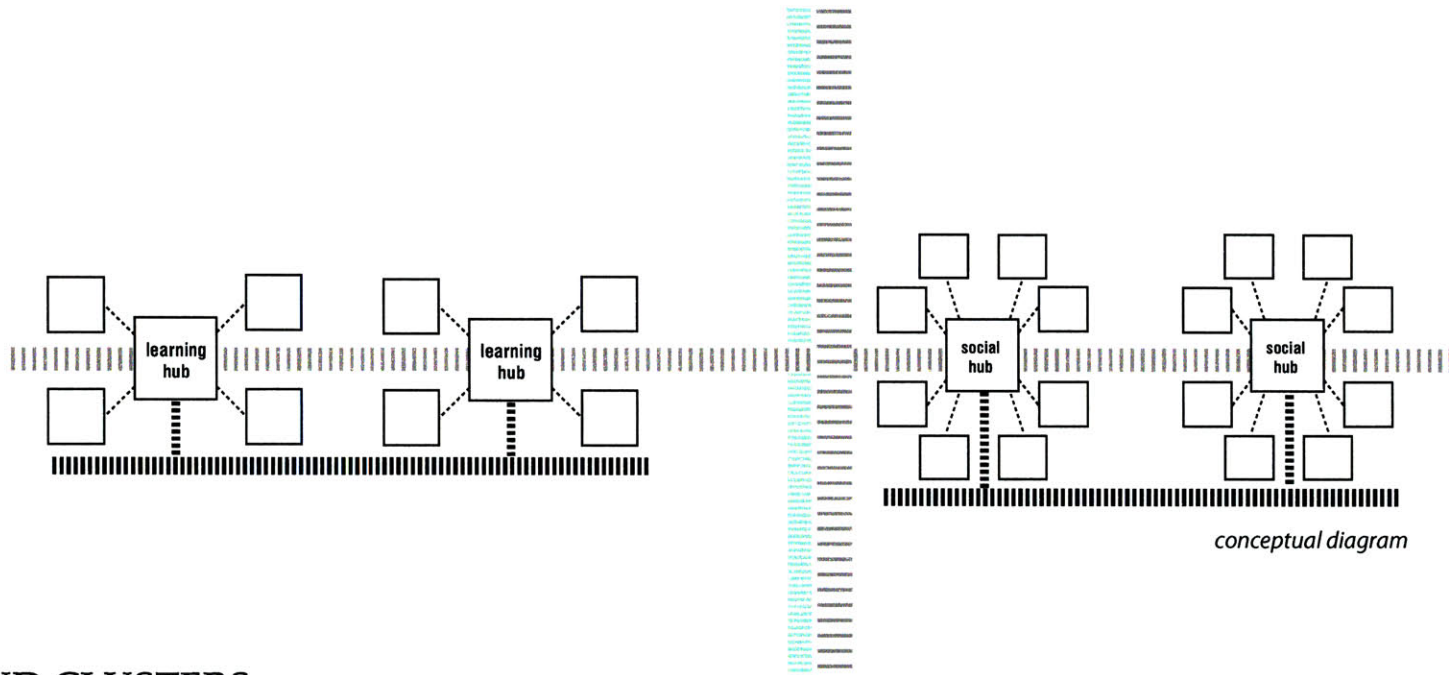

conceptual diagram

SITE AND CLUSTERS

68 | In response to the given program of repetitive classrooms and dormitory rooms, this project proposes a system of clustering around social and learning “hubs” which can be deployed throughout the campus. Both the school and the dorms are built upon an individual cluster of room units, which offers the flexibility of expansion in multiple directions, as well as the opportunity for variation within a systematic construction system.

Urbanistically, the cluster buildings can be deployed in relation to one another in a variety of ways, creating varying scales of outside space including enclosed courtyards, recreational spaces, large gathering places, and vibrant pathways.

A central circulation path runs along the north-south axis of the site, and buildings are aligned along a pedestrian “street.” On the west side of this street, a strip of constructed wetland serves two purposes: it uses natural processes to cleanse and process all of the grey water and storm water from the site, and it provides a natural division between the school and dorm zones which is both beautiful and functional.

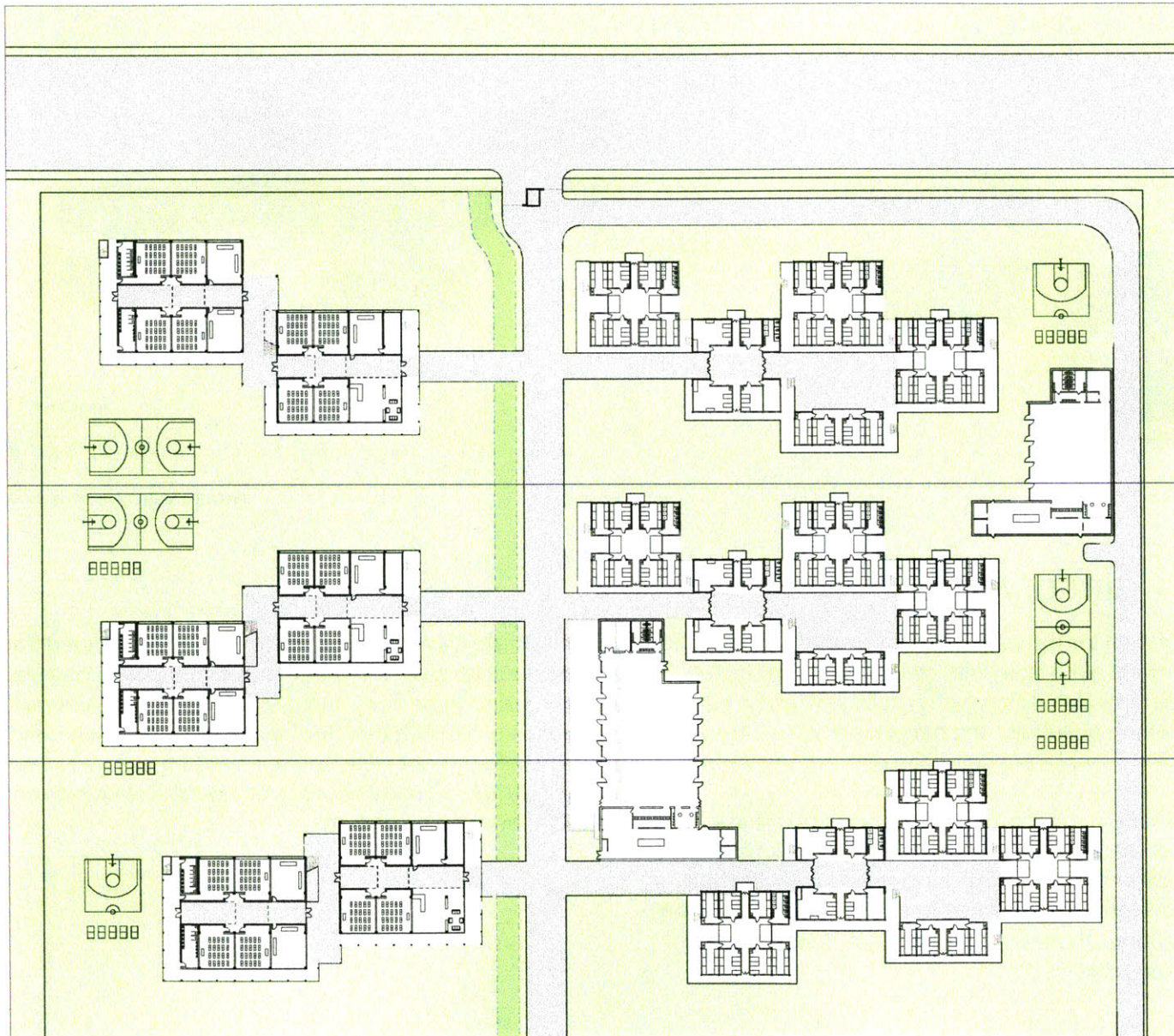

ground level site plan

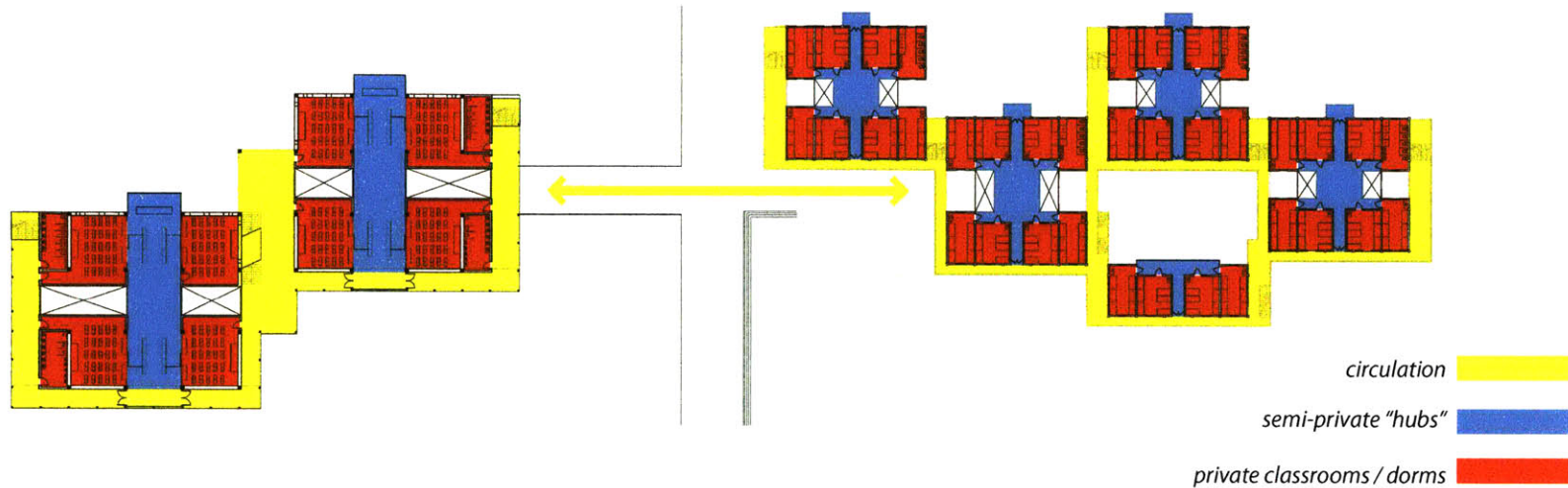

CLUSTERS + CIRCULATION

70 |

The primary circulation for the school and dorm wraps around the southern exterior walls, with stairwells located between clusters. The light-weight steel frame circulation paths contrast with the heavier masonry masses of the buildings. The paths block harsh direct sunlight into the rooms while providing the opportunity for fresh air.

Entrance into the semi-public "hubs" is from the south. These naturally lit shared spaces function as places where groups can informally learn, gather, and socialize. By prioritizing these "hubs" and locating them within a dynamic and airy light well in the heart of each cluster building, moments of unstructured, improvised learning become possible.

The private classrooms and dorm rooms are entered from these intermediate spaces, rather than from the public circulation paths, which tend to be noisy and distracting. Ample natural lighting and ventilation of both the "hub" spaces and classrooms and dorm rooms is ensured by light wells and open atriums, as well as windows to the outside. All rooms have large operable windows on two sides to allow for cross ventilation.

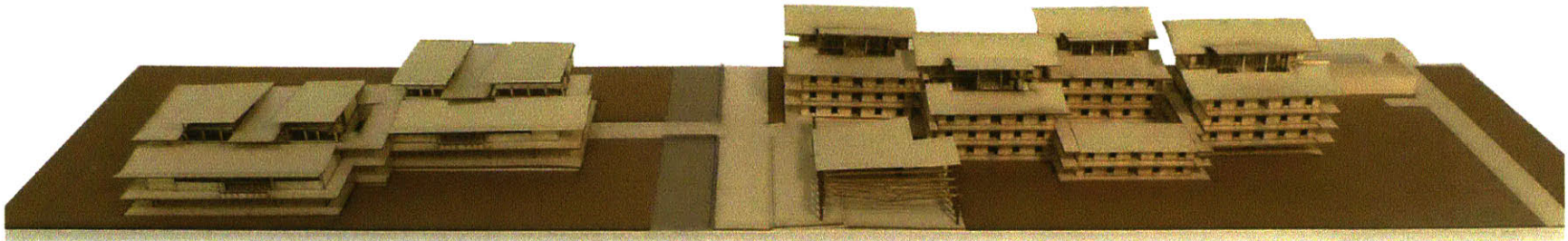

view of model showing classrooms clusters on the left, and dorms clusters on the right

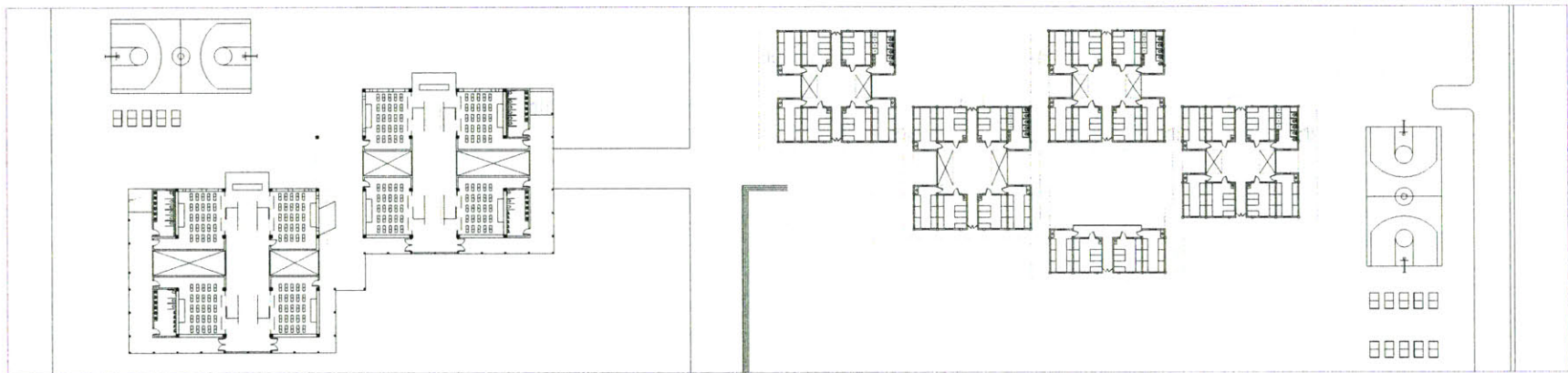

second level plan

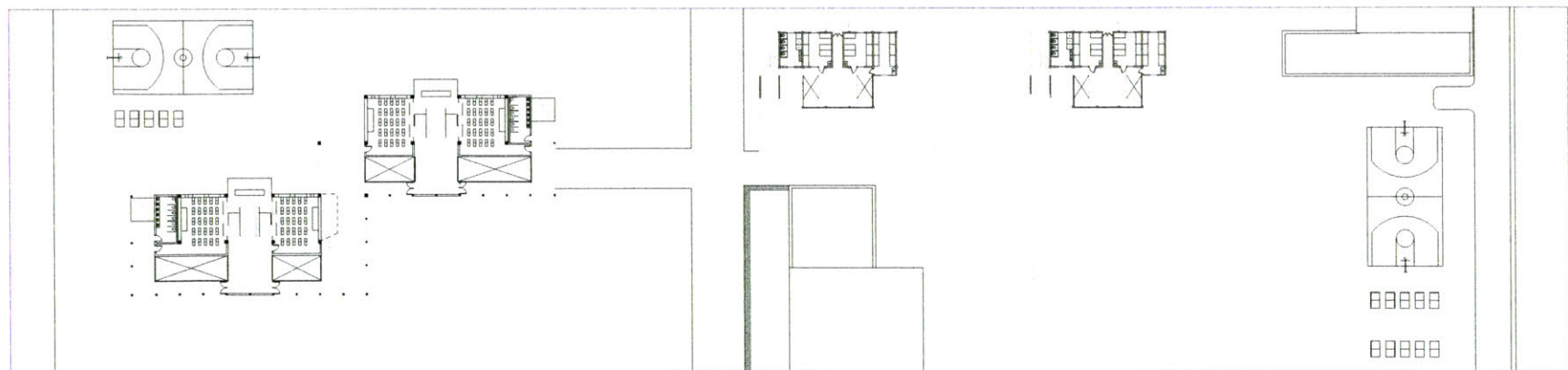

typical upper level plan

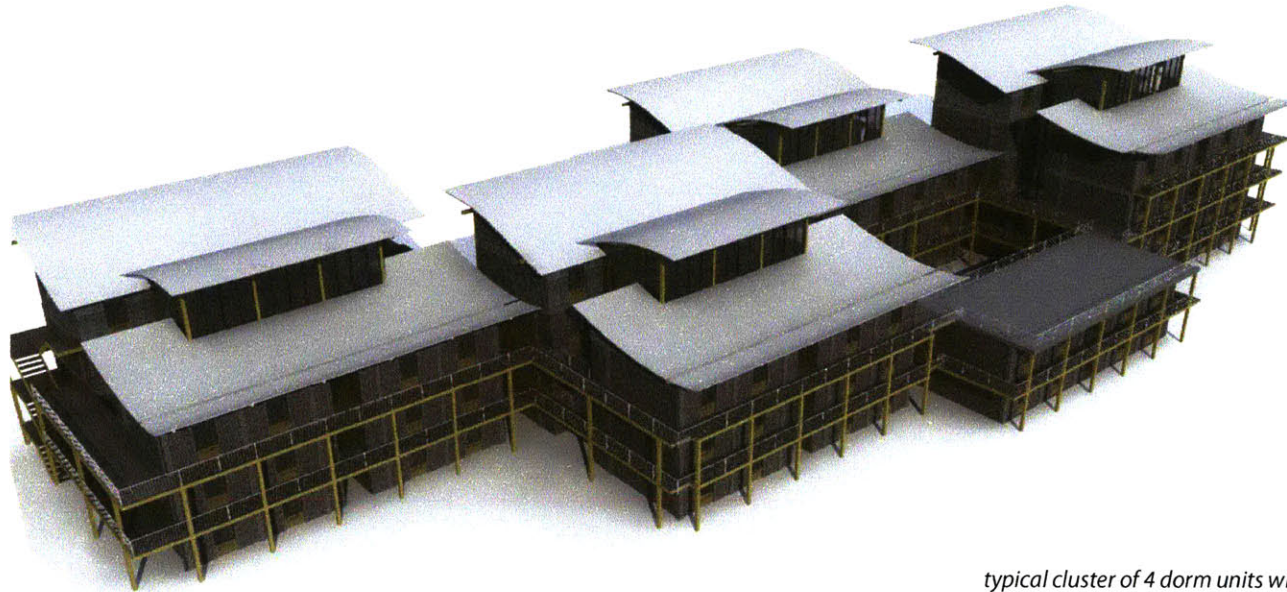

typical cluster of 4 dorm units with a courtyard and roof deck.

DORMS

72| Each dorm cluster is designed around a semi-private gathering space (the “hub”), that serves as an entry into the individual rooms. Seven rooms and one bathroom cluster around each “hub” space and are flanked by two light wells. Each “hub” has a small private balcony, where students can relax, or hang laundry. Large operable windows enclosing the light wells can be opened to allow for ample air flow and ventilation through the rooms and spaces. Each dorm room has two large operable windows and vents which allow natural light to enter and air to flow through.

The primary circulation paths are located on the south, east, and west facades of the buildings, and are constructed of a lightweight steel frame system. They are covered by the large roof overhangs from the lightweight steel roof. By locating the circulation on the

outside of the buildings, interior space becomes free for different types of informal interactions among the residents. The circulation paths also block the hot summer light from entering the rooms directly and causing them to heat up. Low winter sun is allowed to enter, allowing for passive solar heating during the cool winter months.

Access to the courtyard is through a widened cluster to the west of the courtyard, and the larger ground level rooms of this cluster provide housing for dorm monitors. The stairs are on the east and west facades, tucked between the cluster buildings. On these facades, the circulation paths are widened to 4 meters to allow for outdoor gathering spaces for table tennis or other forms of recreation.



view of the entry into the dorms, with the rammed earth dining hall wall on the right

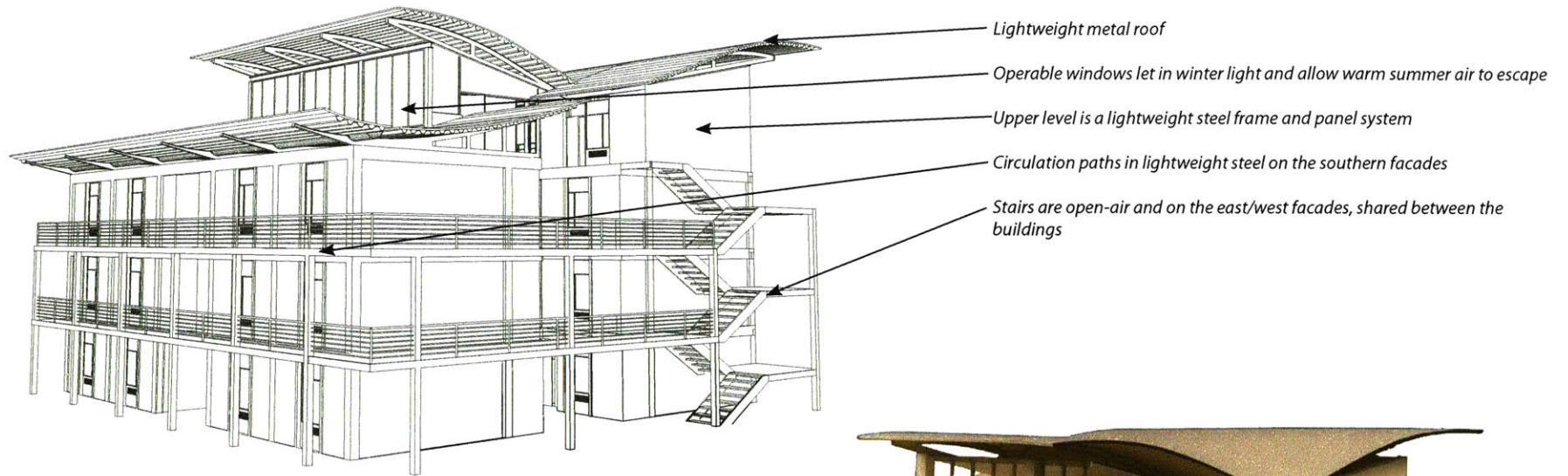

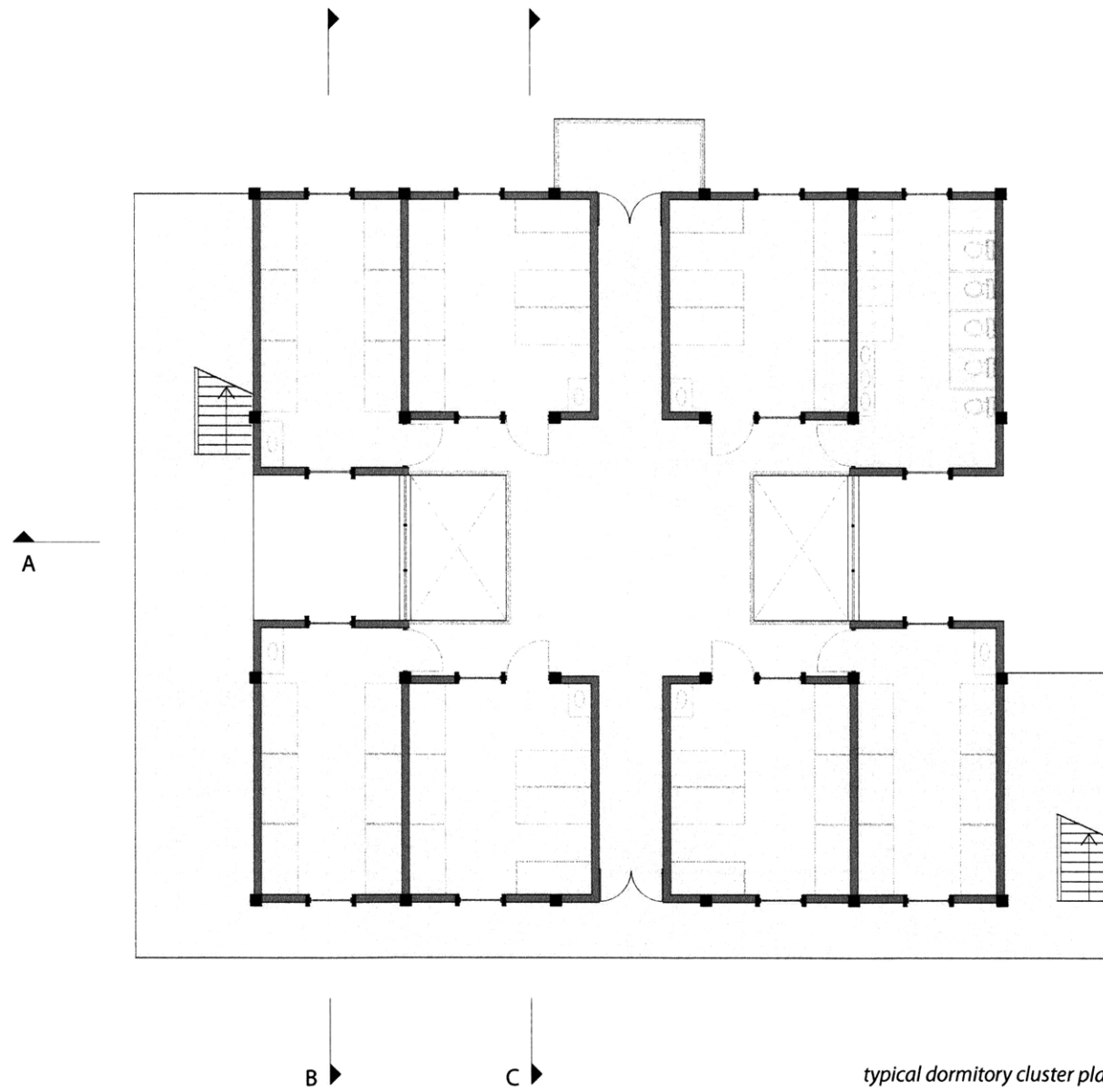

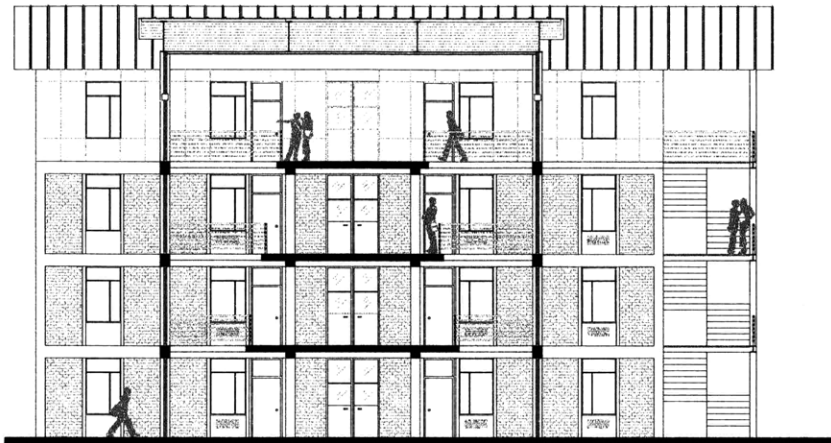

section A

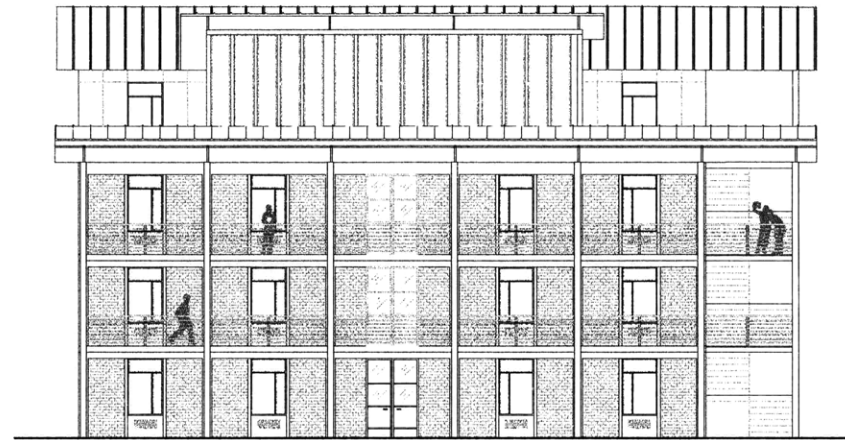

south elevation

76 |

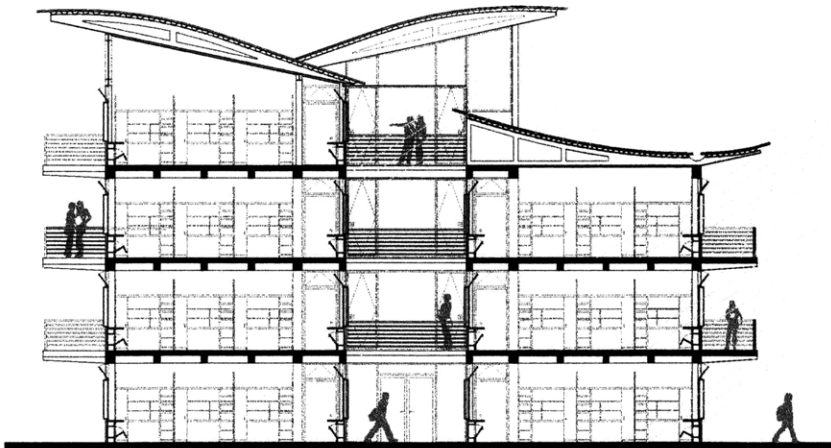

section B
summer/winter sun angles

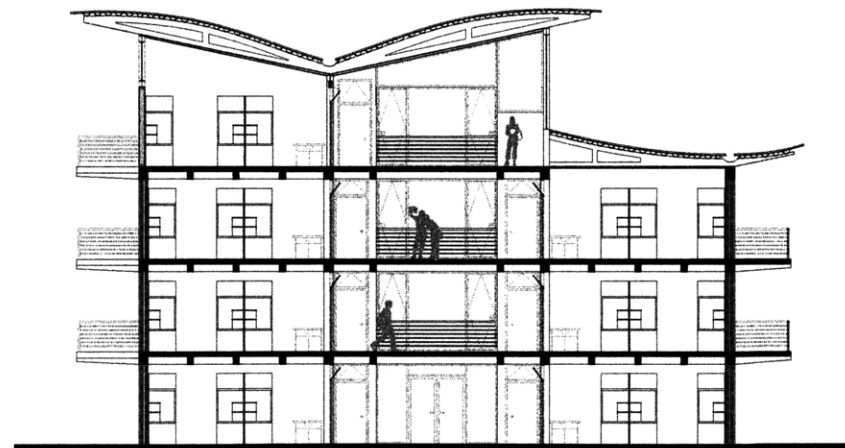

section C



sectional model through "hubs"



night view of light well and entrance to dorms

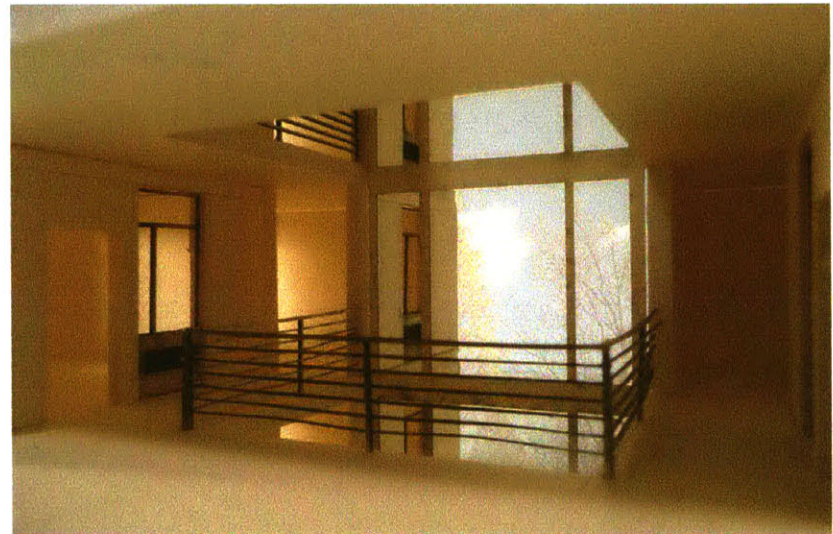

interior view, showing entrances to dorm rooms and light well



interior view of "hub" and atrium



*dorm room interior, with integrated bed, desks and storage.
south facing wall contains operable windows and vents*



view of dormitory courtyard



view from shared roof deck

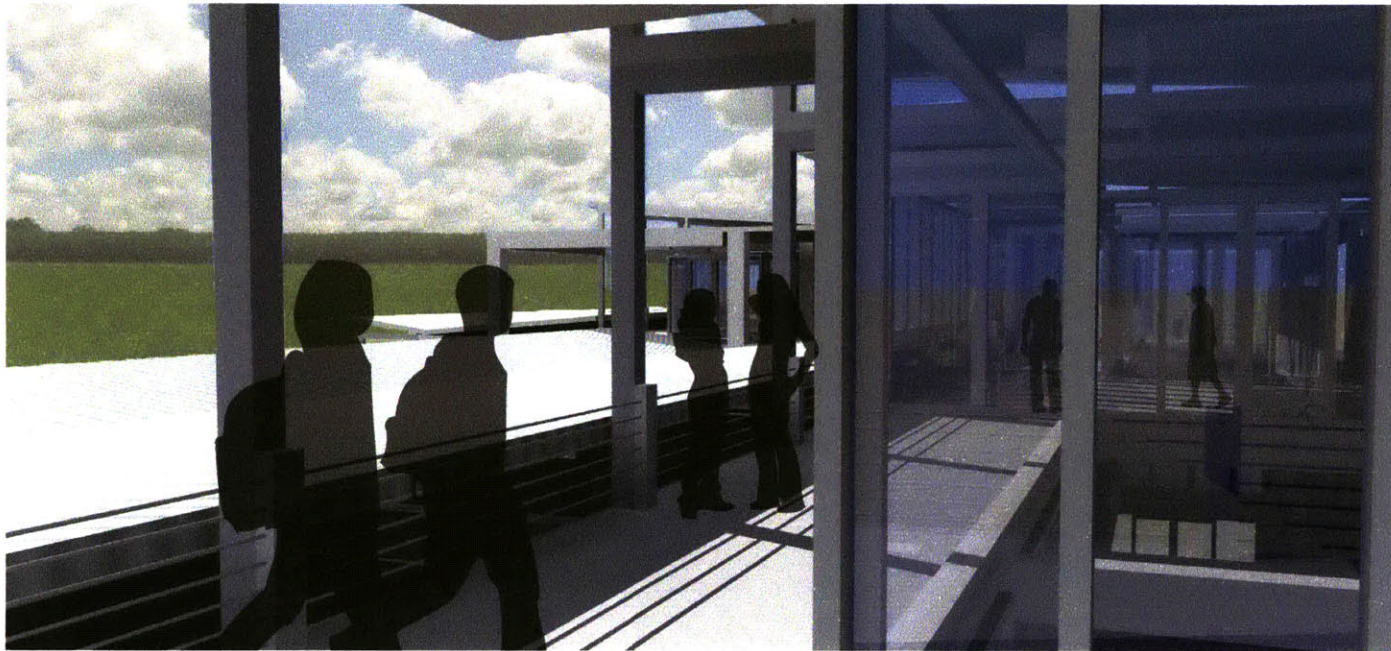

*view of upper level
circulation between hubs*

CLASSROOMS

82 |

Similarly to the dorms, each school unit is centered around a semi-public shared learning “hub” that runs on a north-south axis through the unit, with four classrooms clustered around the “hub.” The classrooms are designed to maximize both privacy and natural light: walls facing the exterior and the central light well have large operable windows to maximize natural light and cross-ventilation, while the massive walls facing public areas are designed to maximize privacy and regulate temperature.

The walls of the classrooms that face the learning hub are made of storage shelves and windows, allowing for cross flow between the two spaces. Movable partitions allow for flexible use of space, and the northern end of the hub functions as a small private study space.

Primary circulation occurs on the south side of the building, where a light weight steel framed system functions as both a shading system for the exterior windows, and as an outdoor gathering place for students.

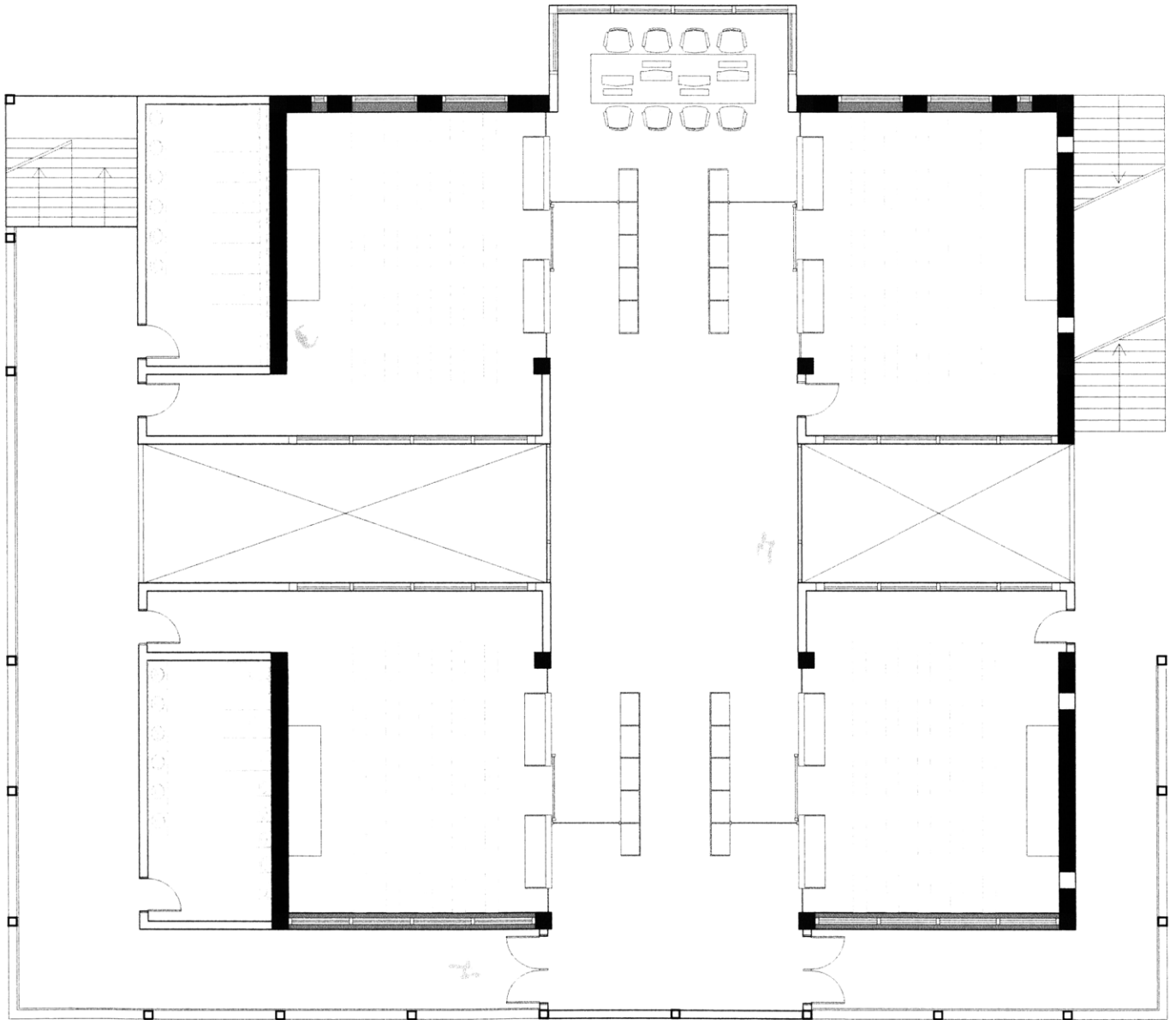

typical upper level plan



sectional model through learning "hub", showing storage shelves and windows along classroom walls

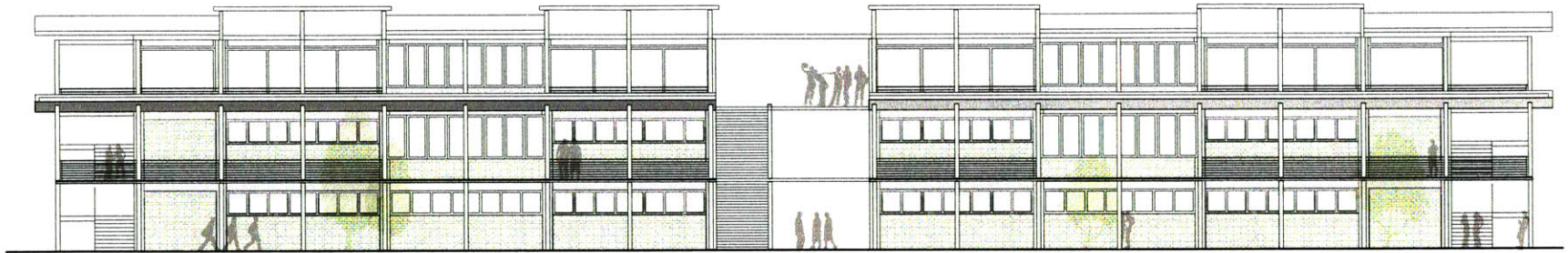

southern elevation

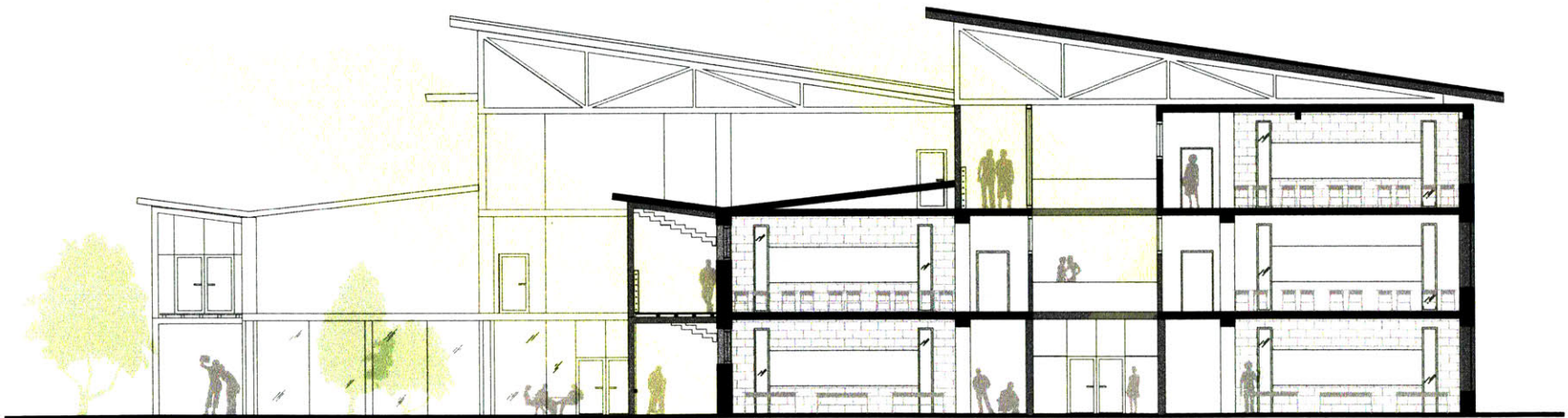

section through classrooms and light well

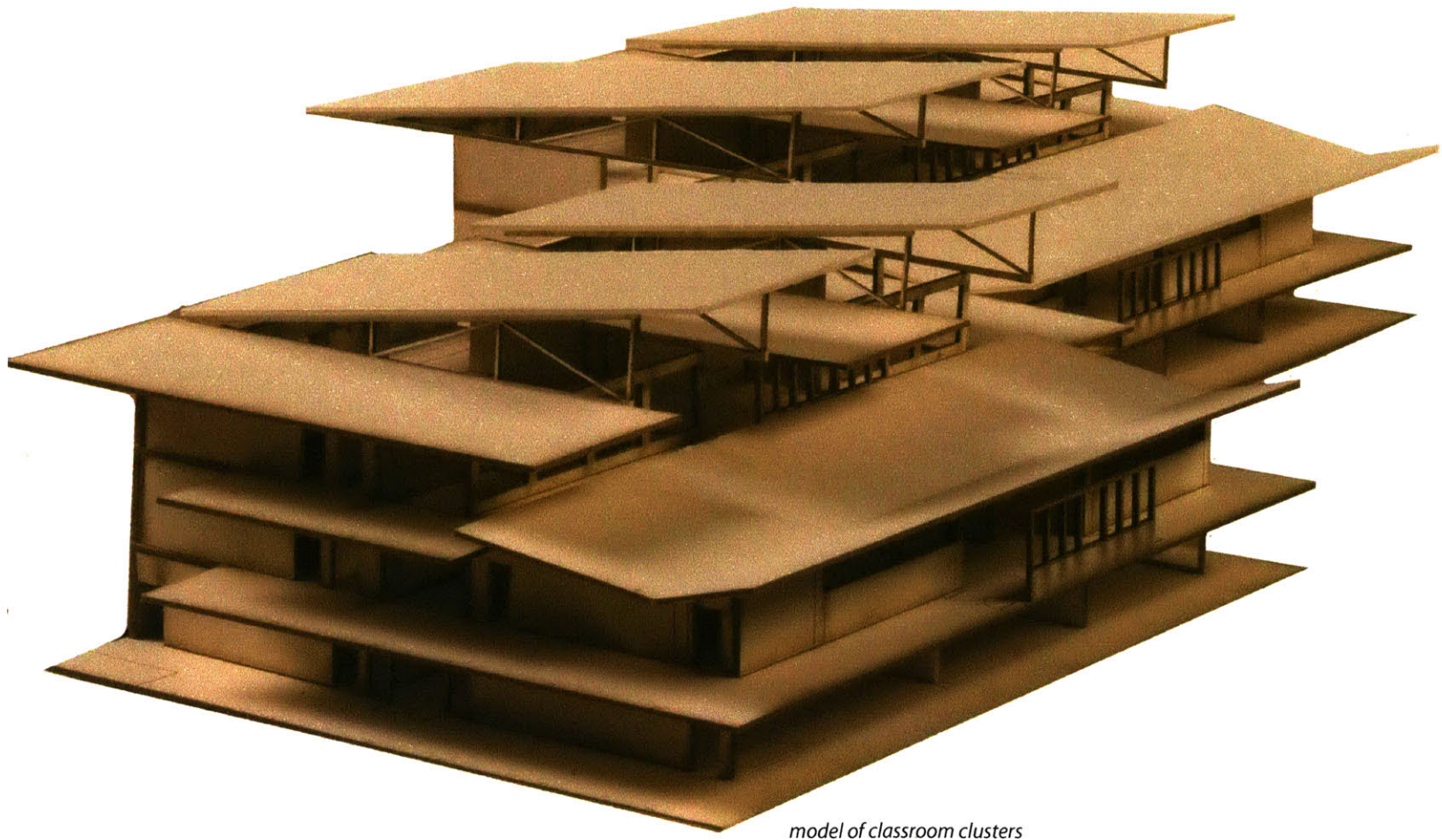

model of classroom clusters



view of shared learning "hub" and storage walls of classrooms

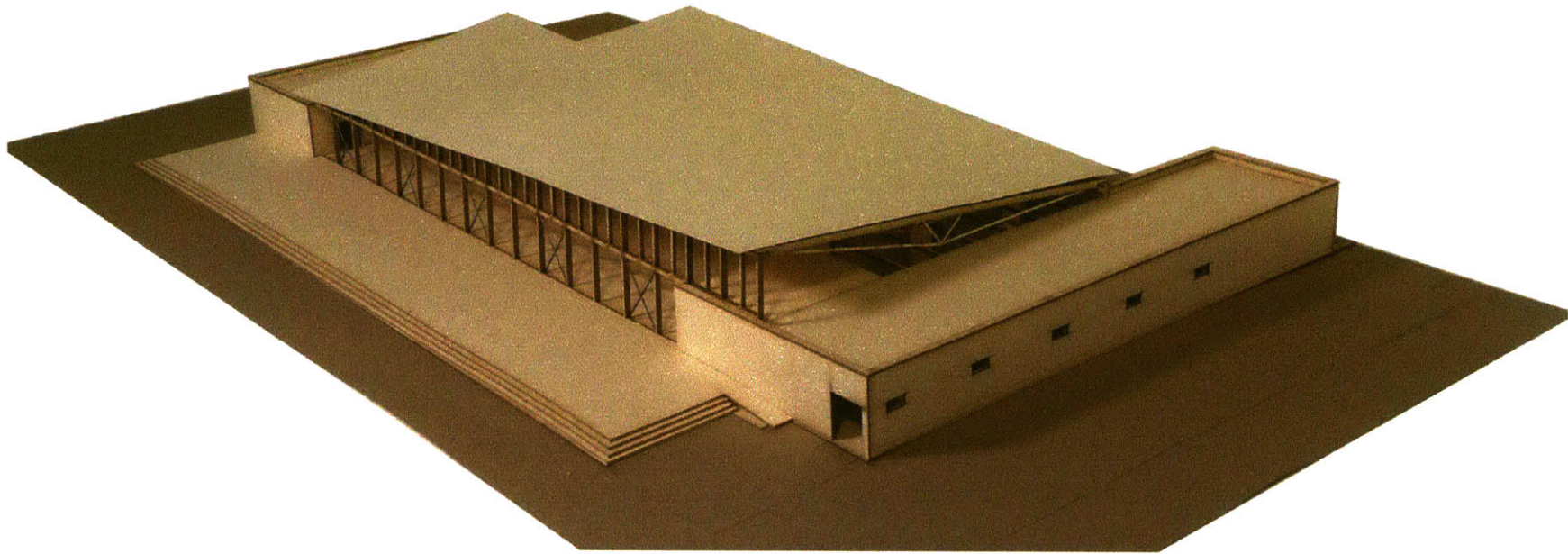

DINING HALL

88 |

While the initial program called for three separate dining halls of approximately 600sm each, they have been consolidated into two halls, one larger than the other. This allows greater flexibility for special events, as the larger hall can be used as a gathering space for all three middle schools. The smaller dining hall is located on the eastern edge of the site, adjacent to the northernmost dorm cluster. This is envisioned to be a more private hall to be used by younger students. The larger hall is centrally located along the main street running between clusters.

The dining hall was conceived as a light framed enclosure stretched between two heavier masses. This juxtaposition of heavy and light construction mirrors the tectonic concepts of the school and dorms, and also marks the distinction between the weighty, earthen masses

of the kitchen and “service” areas with the lightweight trussed roof over the larger “served” space.

A raised plinth extends along the length of the building, with terraced steps leading up from the street up to an outdoor eating and gathering area that flows directly into the building, blurring the line between interior and exterior. Pivoting doors and glazing on both the east and west facades allow for free circulation and ventilation across the building, while maintaining a visual link across the site. The low, rammed-earth walls on the northern and southern edges of the building help define the primary circulation paths from school buildings to their respective dorms, while the twisting roof slopes upward to meet the adjacent buildings.

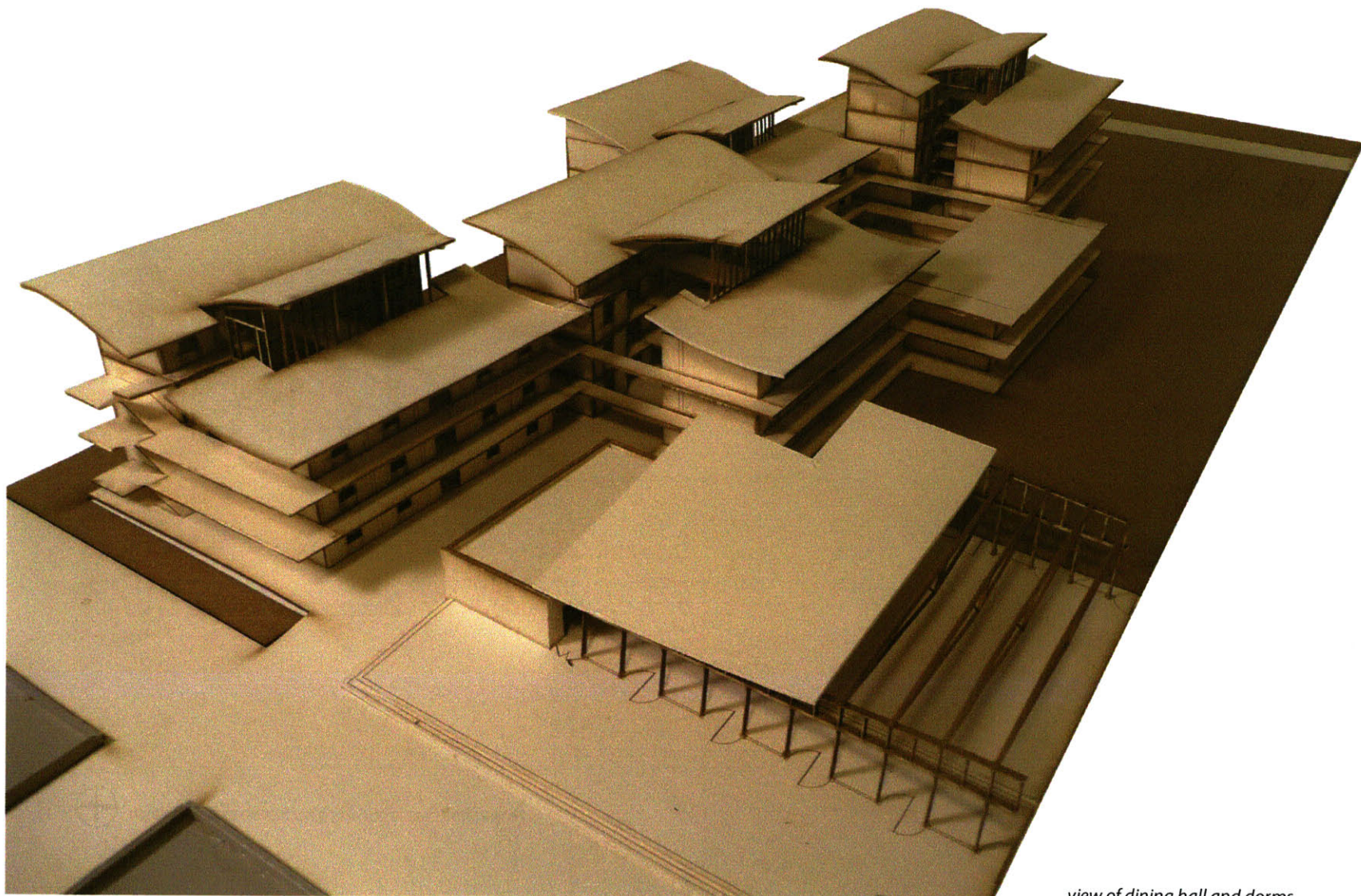

view of dining hall and dorms

90 |

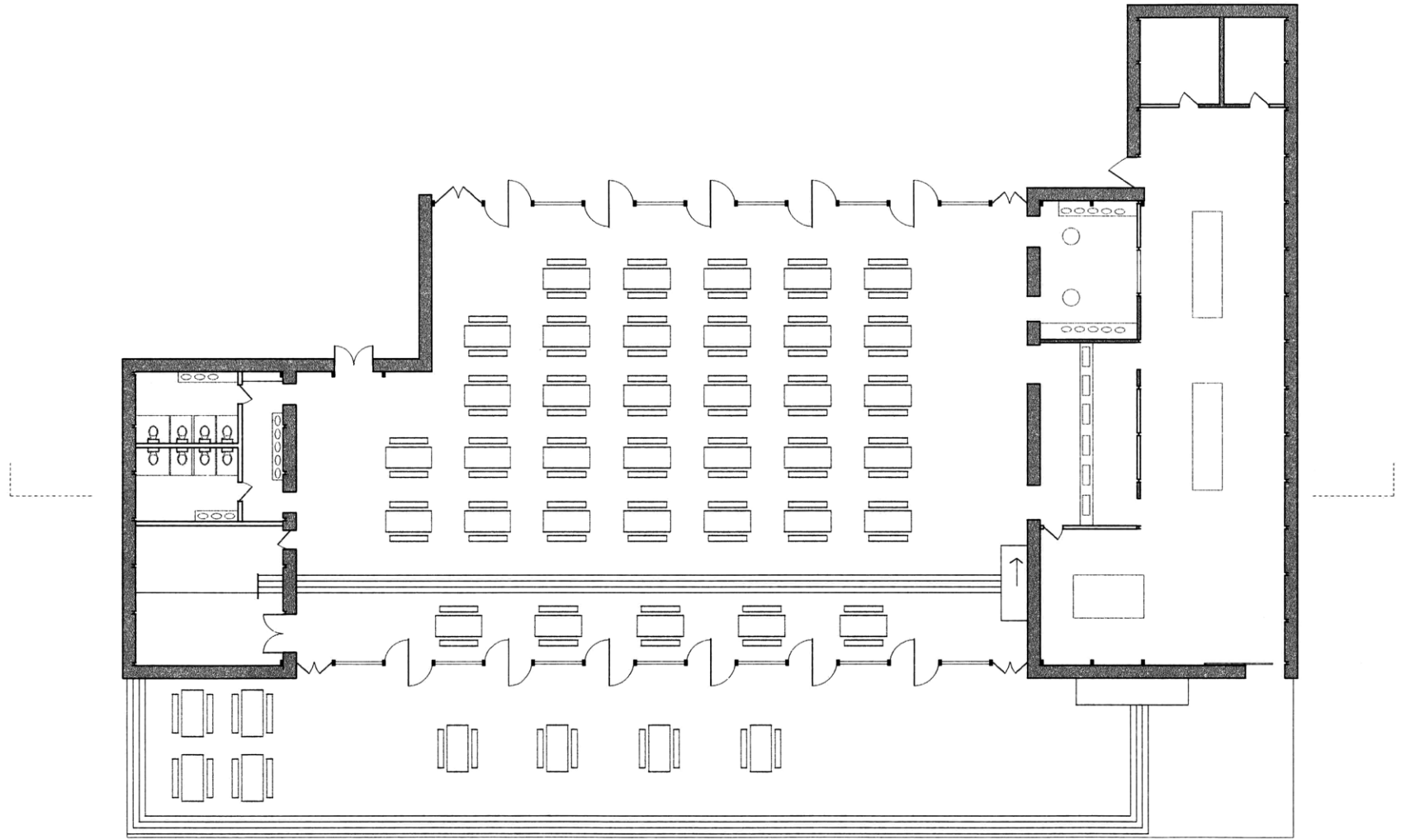

dining hall plan, showing benches on exterior plinth 

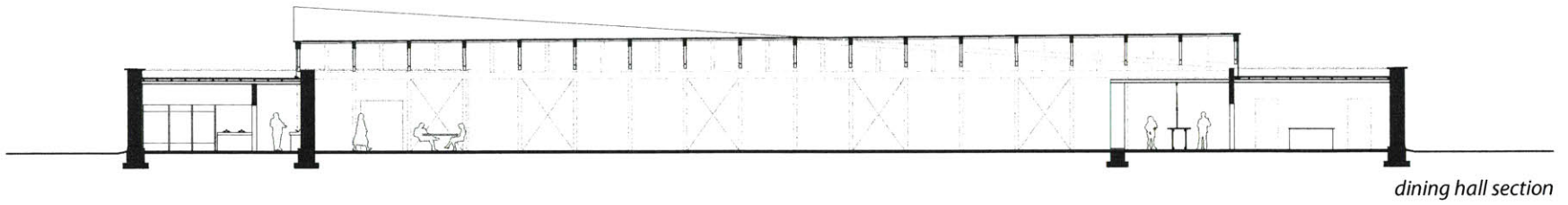

dining hall section

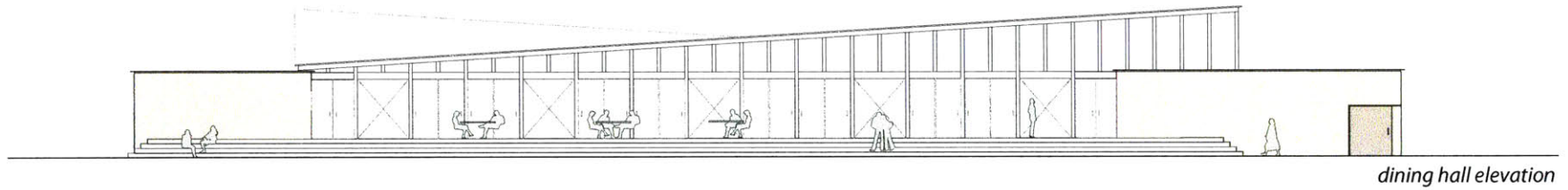

dining hall elevation

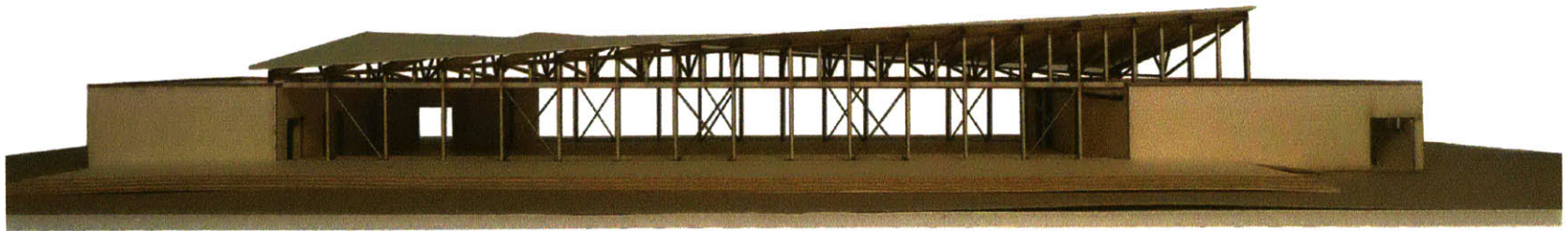

view of dining hall from central pedestrian street

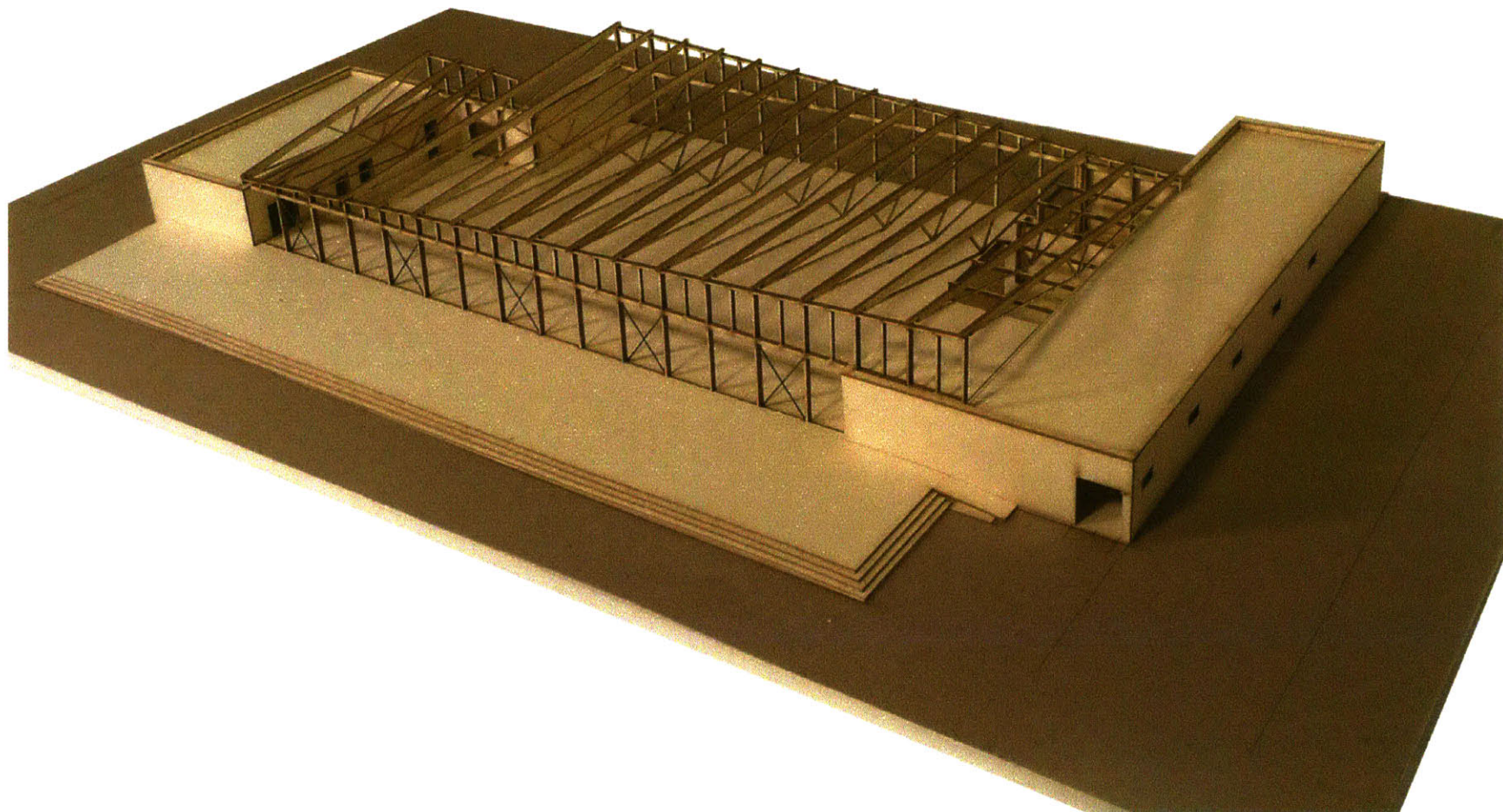

*lightweight rotating truss structure, stretched between
rammed earth masses to the north and south*





dining hall kitchen entrance



dining hall rear entrances

APPENDIX

The most important task of education is the insertion of the individual into the community through the development of a sense of personal responsibility, in such a way that the community that results represents more than the sum total of individuals it contains. This aspect of education cannot be taught directly, it is rather a matter of general experience and the gradual formation of consciousness which allows the individual to find the right contact with public life and with the political community.

- Hans Scharoun

INITIAL RESEARCH

98 |

I began by exploring the notion of the classroom as the underlying unit behind education. How can the classroom adapt as the needs of its users change? Flexible classroom sizes and orientations, outdoor space, incorporated storage and breakout spaces form a classroom unit, which can be repeated and clustered together.

Breaking away from the typical school corridor typology, the clustering of the units promotes the concept of corridors as identifiable space, rather than simply a link. Semi-private gathering spaces exist within public areas, while open gardens and courtyards bring in natural light, and blur boundaries between interior and exterior.

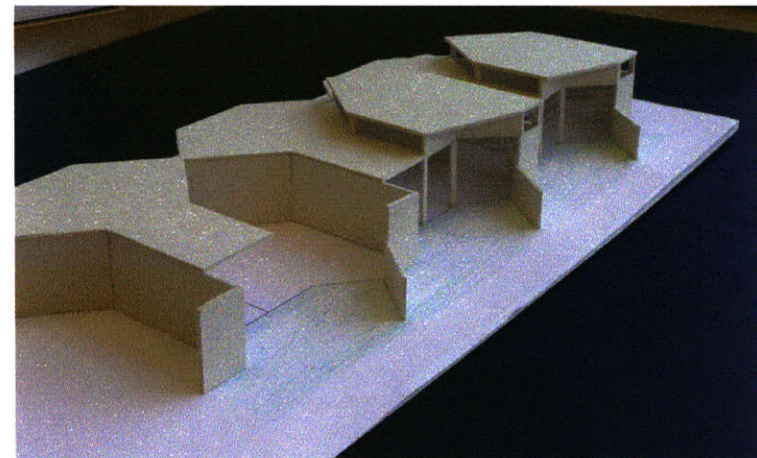

initial concept model showing clustered units

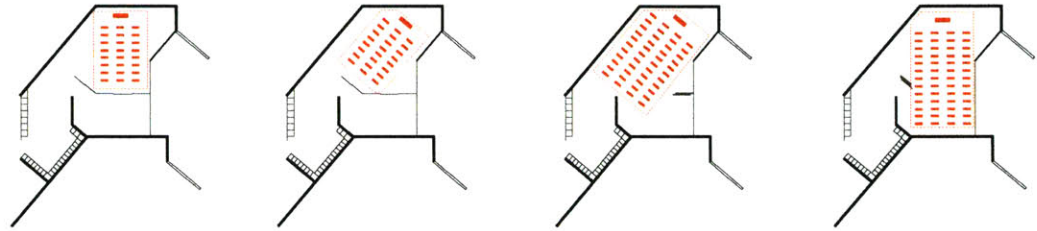
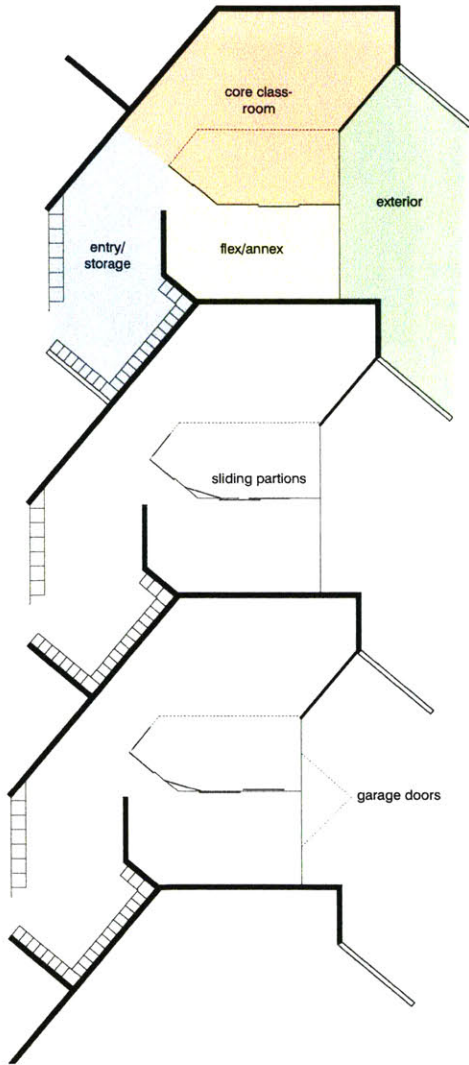

classroom size and orientation

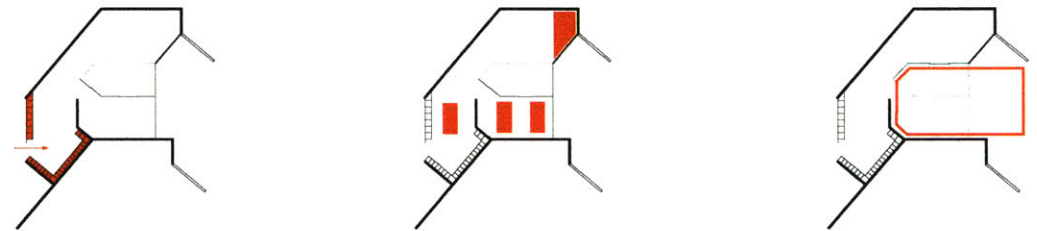

non-disruptive entry space and storage

small group work areas

indoor / outdoor class

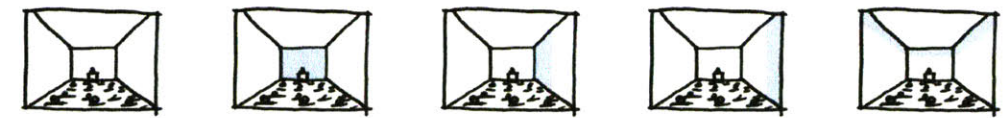

classroom lighting options

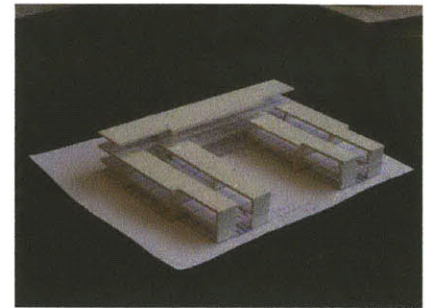
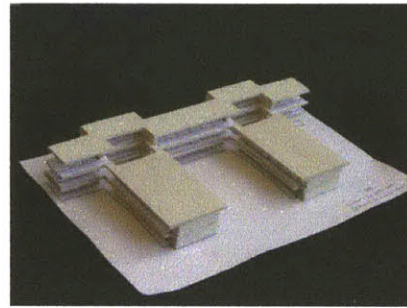
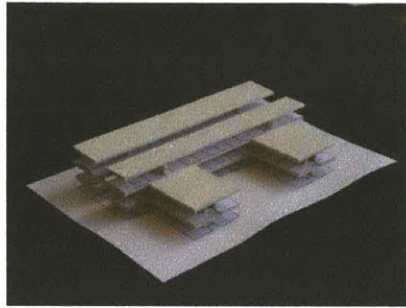
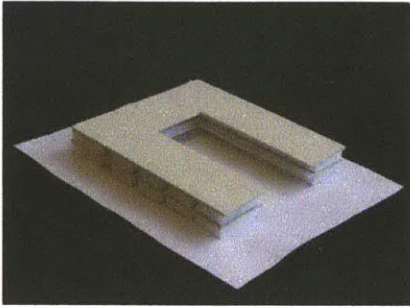

study models

100 |

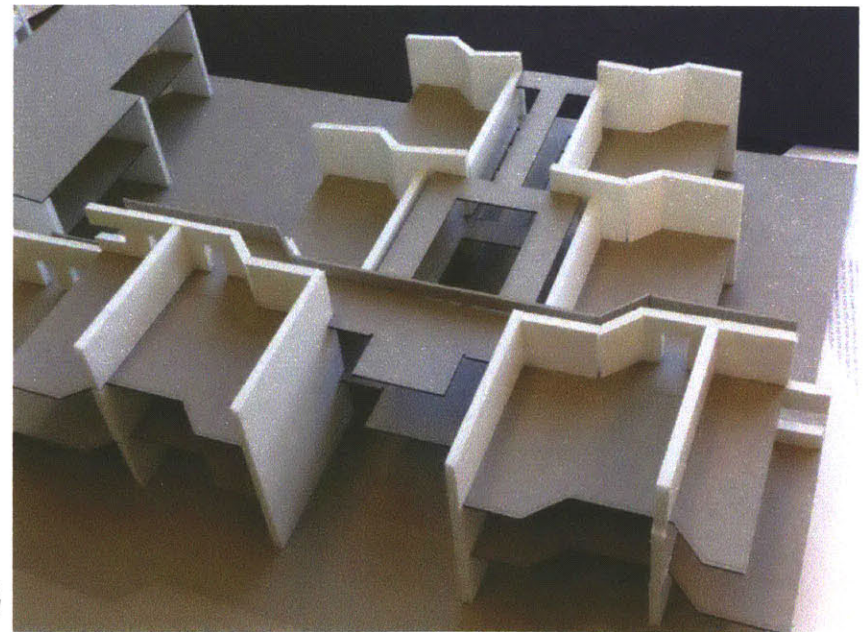

initial model showing heavy masonry construction with "floating" walkway above courtyard

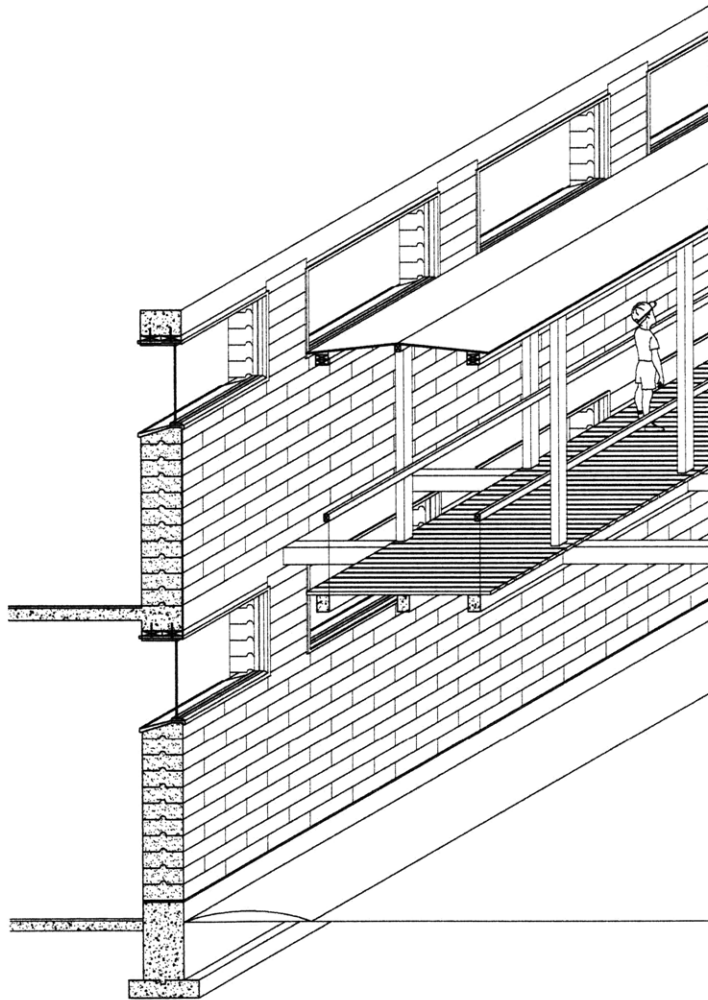

axonometric section showing "floating" walkway and wall construction

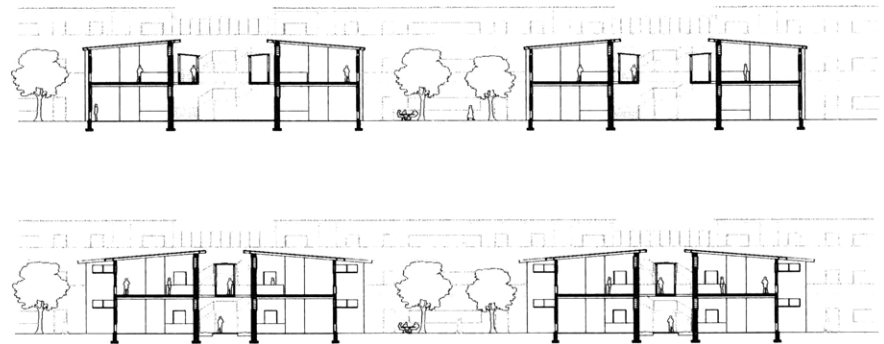

sectional studies through floating walkways and courtyards

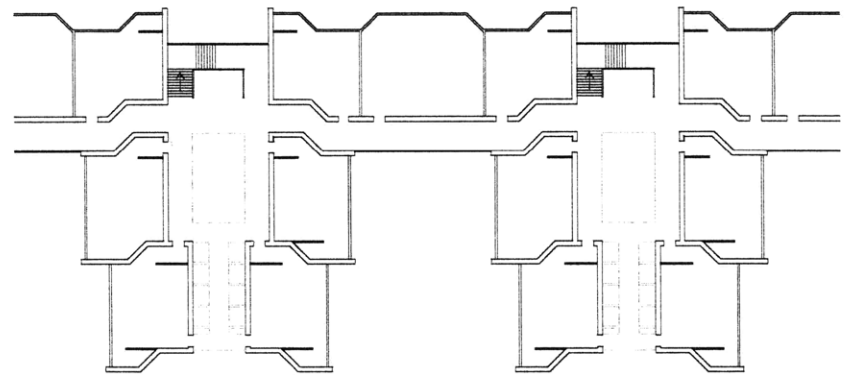

ground floor plan

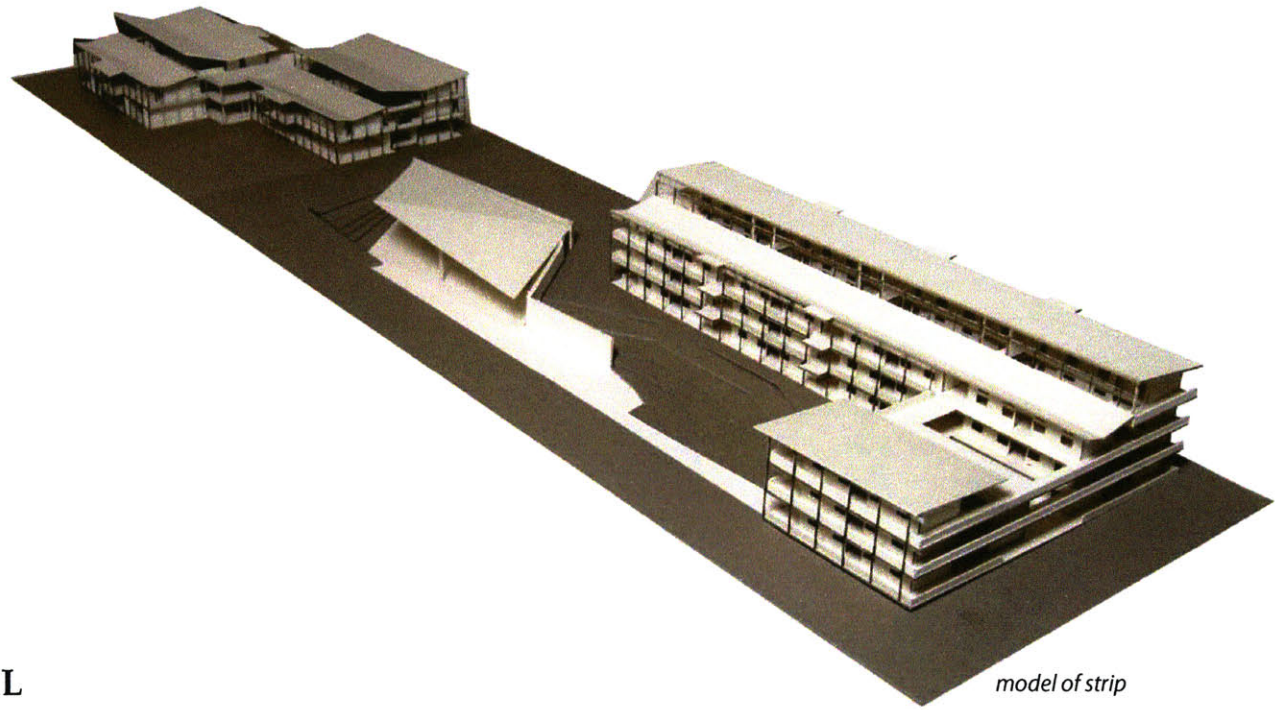

model of strip

MID-TERM PROPOSAL

102|

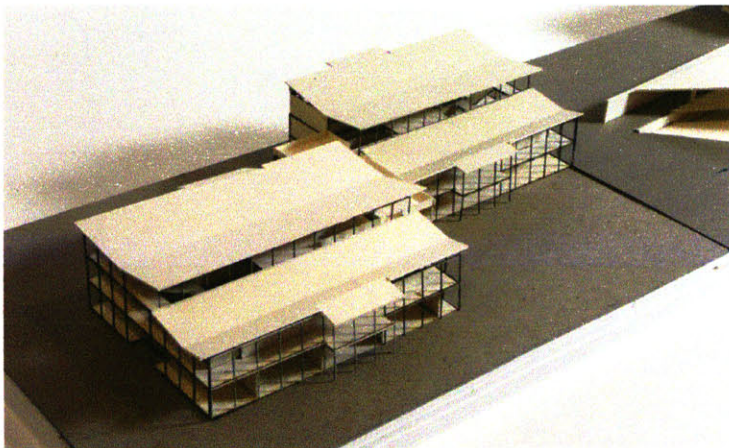

classroom model

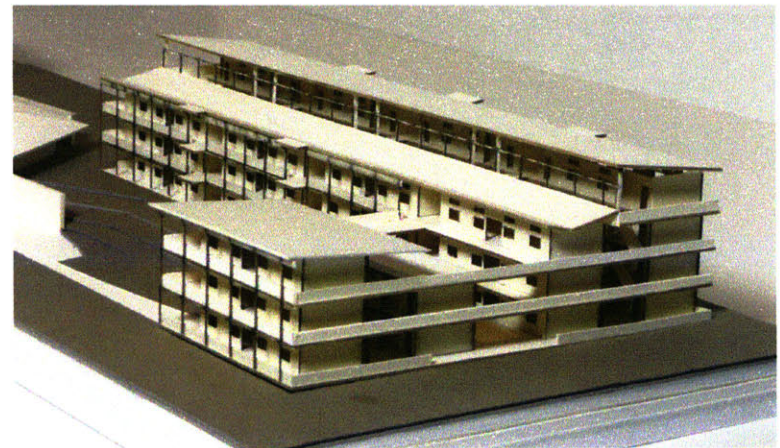

dormitory model



dormitory section through roof deck and courtyard

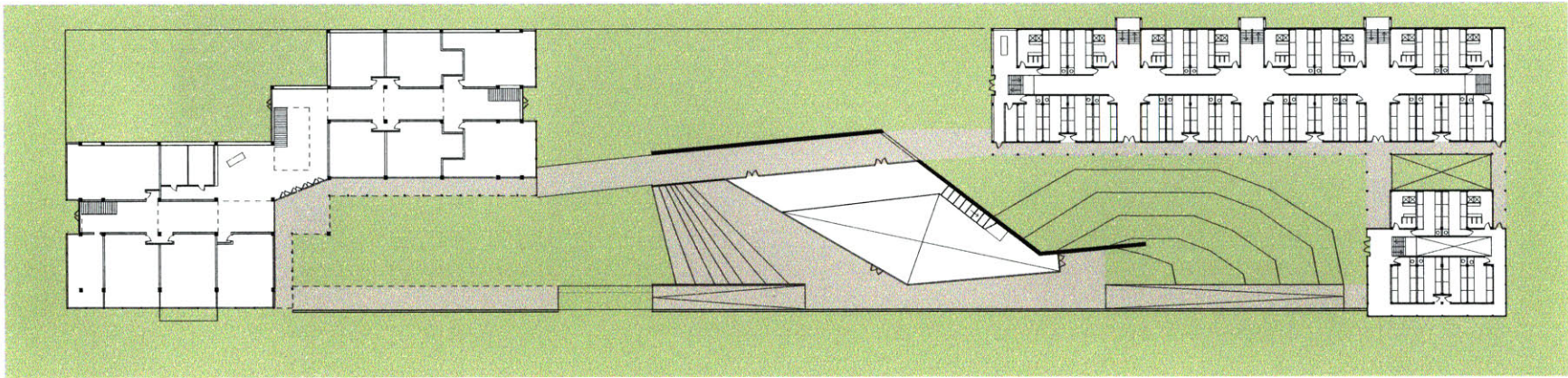

ground level plan



strip elevation

BIBLIOGRAPHY

All images and illustrations are by the author, Ethan Lacy and Erica Weiss, unless, otherwise specified:

- page 9: Steven Preston
- page 10: Guiquan Sun
- page 16: *(right)* Kanda Song
- page 23: Kenneth Frampton, based on Semper's sketches
- page 24: *(left)* © greg hurley
- page 25: *(top)* <http://flickr.com/photos/marshsu/70866162/>
(bottom) © Alejandro Leveratto
- page 28: *(left)* Kenneth Frampton
(right) http://www.thelivingmoon.com/43ancients/02files/Pyramids_World_02.html
- page 29: *(top)* © Matthew Field
- page 30-31: © Christian Richters
- page 32: http://blog.sina.com.cn/s/blog_3f7fd78e01009pkh.html
- page 38-39: © Steen Heilesen
- page 46-47: Jiakun Architects
- page 48: *(left)* Jiakun Architects
- page 50-51: Hsieh Ying Chun
- page 58: source unknown
- page 60: Hsieh Ying Chun

Anderson, Stanford, ed. *Eladio Dieste: Innovation in Structural Art*. Princeton: Princeton University Press, 2004

Ando, Tadao. "Shintai and Space," in *Architecture and Body*. New York: Rizolli, 1988

Blundell-Jones, Peter. *Hans Scharoun*. London : Phaidon Press, 1995

Botticher, Karl. *Die Tektonik der Hellenen*. 2 vols. Potsdam, 1852

Frampton, Kenneth. *Studies in Tectonic Culture*. Cambridge: The MIT Press, 1996

Giedion, Sigfried. *Space, Time and Architecture*. Cambridge: Harvard University Press, 1941; 2d ed. 1955

Heidegger, Martin. "On the Origin of the Work of Art," in *Poetry, Language, Thought*. New York: Harper & Row, 1971

Hermann, Wolfgang, trans. and intro. *In What Style Should We Build? The German Debate on Architectural Style*. Santa Monica: Getty Center for the History of Art and the Humanities, 1991

Kögel, E. and U. Meyer, curators. *Tu Mu: Young Architecture of China*. Aedes East Forum: Beijing, 2001

Laugier, Marc-Antoine. *Essai sur l'architecture*. Paris, 1753. English translation as *An Essay on Architecture*; Los Angeles: Hennessey & Ingalls, 1977

Muller, Karl Otfried. *Ancient Art and Its Remains, or a Manual of the Archaeology of Art*. Trans. J. Leitch. London, 1847

Semper, Gottfried. *Style in the Technical and Tectonic Arts*. Trans. Harry Francis Mallgrave and Michael Robinson. Los Angeles: The Getty Research Institute, 2004

Semper, Gottfried. *The Four Elements of Architecture and Other Writings*. Trans. Harry Francis Mallgrave and Wolfgang Herrmann. Cambridge: Cambridge University Press, 1989

Stokes, Adrian. "The Stones of Rimini" in *The Critical Writings of Adrian Stokes*, vol. 1. London: Thames & Hudson, 1978

Utzon, Jorn, "Platforms and Plateaus: The Ideas of a Danish Architect." *Zodiac* 10, 1962

The Utzon Library: Utzon and the New Tradition. The Danish Architectural Press: Copenhagen, 2005

Walker, Peter, et. al. *Rammed Earth: Design and Construction Guidelines*, Watford: BRE Bookshop, 2005