

# The Exploration of Concepts for Projectile Toys

by

William J. Fienup  
B.S. Mechanical Engineering  
Massachusetts Institute of Technology, 2003

Submitted to the Department of Mechanical Engineering  
in Partial Fulfillment of the Requirements for the Degree of  
Master of Science in Mechanical Engineering

and

Barry M. Kudrowitz  
B.S. Mechanical Engineering  
University of Central Florida, 2004

Submitted to the Department of Mechanical Engineering  
in Partial Fulfillment of the Requirements for the Degree of  
Master of Science in Mechanical Engineering

at the

MASSACHUSETTS INSTITUTE OF TECHNOLOGY

June 2006

©Massachusetts Institute of Technology 2005. All rights reserved.

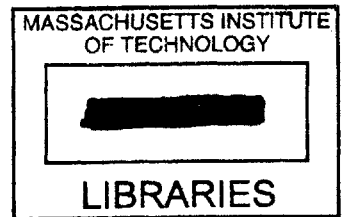
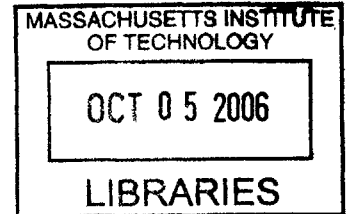

**BARKER**

Signature of Author.....

 Department of Mechanical Engineering  
May 22, 2006

Signature of Author.....

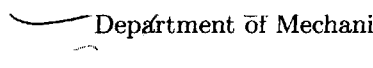
 Department of Mechanical Engineering  
May 22, 2006

Certified by.....

 David Wallace  
Esther and Harold E. Edgerton Associate Professor, Co-Director MIT CADlab  
Thesis Supervisor

Accepted by.....

 Lallit Anand  
Chairman, Department Committee on Graduate Students

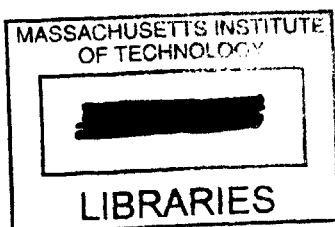



Room 14-0551  
77 Massachusetts Avenue  
Cambridge, MA 02139  
Ph: 617.253.2800  
Email: docs@mit.edu  
<http://libraries.mit.edu/docs>

## **DISCLAIMER OF QUALITY**

Due to the condition of the original material, there are unavoidable flaws in this reproduction. We have made every effort possible to provide you with the best copy available. If you are dissatisfied with this product and find it unusable, please contact Document Services as soon as possible.

Thank you.

**Due to the quality of the original material there is some bleed through.**

[REDACTED]

[REDACTED]

# The Exploration of Concepts for Projectile Toys

by

William J. Fienup and Barry M. Kudrowitz

Submitted to the Department of Mechanical Engineering  
on May 22nd, 2006 in partial fulfillment of the  
requirements for the degree of  
Master of Science in Mechanical Engineering

## Abstract

The goal of this research has been to develop new concepts for foam projectile toys. The team followed a standard design practice and brought two unique concepts to an alpha-prototype level. Through brainstorming sessions the team generated over 100 concepts of which the sponsor selected twelve high potential concepts for first order prototyping. Of these prototypes, the team chose two concepts worthy of refinement and further development. The operational principles of the highest potential concepts were thoroughly analyzed and developed through a series of prototypes.

The first concept, Hopper Popper Activation, involved using a bi-stable rubber spring to propel foam balls. This concept created a simple, space-saving, and effective means of storing energy. The hopper popper was implemented in several devices, the most successful being a small hand held toy called the Hand Popper. The greatest issue of concern with the Hopper Popper Activated concepts was the force required to load the toy. The final design implemented a low friction system with a ball guiding channel to reduce this loading force. The final design required a lower operational force than the comparable product on the market, while capable of propelling foam balls 20% further.

The second concept, eDarts, involved incorporating a capacitor powered micro-circuit and LED into foam darts similar to those used in the current line of Nerf® products. The eDarts created a tracer shot or “laser bullet” effect when used in low light conditions. Safety, projectile mass, and axially symmetric loading were the greatest issues of concern. The final suggested eDart incorporated a standard DC power connection with a simple mechanical switch. The eDarts reached comparable distances to the current foam darts on the market, while maintaining a safe Kinetic Energy Density.

Thesis Supervisor: David Wallace

Title: Esther and Harold E. Edgerton Associate Professor, Co-Director MIT CADlab



## Acknowledgments

The design team would like to thank several people for their assistance with this project. Foremost, Professor David Wallace has provided much of his time and advice. We are unable to express how much we admire him and his many abilities. We would like to thank our sponsor, Hasbro<sup>®</sup>, for their generosity and guidance throughout the process. We give special thanks to Amanda Bligh, Bill Gajda, and Leif Askeland from Hasbro<sup>®</sup>. This was an amazing experience and we are fortunate our sponsor provided the opportunity. The team would like to thank Dick Fenner, Joe Cronin, Bob Gertsen, Bob Nuttall, and Steve Haberek for assisting us in the machine shop. We would also like to thank Maureen Lynch and Leslie Regan for their administrative wisdom. The team would like to thank those that helped with our research and development: Zia Sobhani, Josh Weaver, Brenden Epps, Shauna Jin, William Becker, Timothy Vanderpoel, Professor Woody Flowers, Professor Alex Slocum, Amy Banzaert, and Professor Anette Hosoi. We would like to thank those that helped edit the document: Professor David Wallace, Amy J. Fienup Kramer, Joshua D. Kramer, and Maureen Lynch. We are also very appreciative of our peers in the CADLAB who supported us and put up with our antics: Thank you Iason Chatzakis, Jacob Wronski, Monica Rush, Andrew Carvey, Stacy Figueredo, Qing Cao, Sangmok Han, Sittha Sukkasi, Wei Mao, Vishal Saxena and Keiko. Finally, Bill and Barry would like to thank their families for their love and support throughout this project.

Bill Fienup would like to thank Barry.

Barry Kudrowitz would like to thank Bill.

We like to thank each other often.

Thank you.

Thanks.

Welcome.



# Contents

- 1 Introduction 19**
  - 1.1 Objective . . . . . 19
  - 1.2 Outcomes . . . . . 19
    - 1.2.1 Hopper Popper Activation (Hand Popper) . . . . . 20
    - 1.2.2 LED Darts (eDarts) . . . . . 21
  - 1.3 About this Thesis . . . . . 22
  
- 2 Planning 25**
  - 2.1 Customer Needs . . . . . 25
  - 2.2 State of the Art . . . . . 27
  - 2.3 Standards and Safety . . . . . 29
  
- 3 Ideation 31**
  - 3.1 Introduction . . . . . 31
  - 3.2 Brainstorming . . . . . 31
    - 3.2.1 Distilling to 30 High Potential Concepts . . . . . 33
    - 3.2.2 Ranking and Focusing . . . . . 36
  - 3.3 Sketch Models . . . . . 38
    - 3.3.1 String Shooter . . . . . 38
    - 3.3.2 Rocket Darts/Matrix Darts/Fart Darts . . . . . 41
    - 3.3.3 Mist Blaster . . . . . 44
    - 3.3.4 Water “Chunks” . . . . . 46
    - 3.3.5 Foam Grenade / Hopper Popper Activation . . . . . 51



3.3.6	LED Darts . . . . .	60
3.4	Summary . . . . .	68
<b>4</b>	<b>Hopper Popper Activation</b>	<b>69</b>
4.1	Detailed Design . . . . .	69
4.1.1	Foam Grenade . . . . .	70
4.1.2	Hand-Popper . . . . .	76
4.2	Refining the Concept . . . . .	81
4.2.1	Understanding the Popper . . . . .	81
4.2.2	Means of Lowering the Loading Force . . . . .	89
4.2.3	Final Hand Popper Iteration . . . . .	97
4.3	Summary . . . . .	101
<b>5</b>	<b>LED Darts (eDarts)</b>	<b>103</b>
5.1	Detailed Design . . . . .	103
5.1.1	eDart (1st Iteration) - Conductive Paint Contacts . . . . .	106
5.1.2	eDart (2nd Iteration) - Stereo Connection . . . . .	109
5.2	Refining the Concept . . . . .	120
5.2.1	eDart Analysis . . . . .	120
5.2.2	Final Design Suggestions . . . . .	125
5.3	Summary . . . . .	132
<b>6</b>	<b>Conclusion</b>	<b>135</b>
6.1	Summary . . . . .	135
6.1.1	Hopper Popper Activation (Hand Popper) . . . . .	135
6.1.2	LED Darts (eDarts) . . . . .	136
6.2	Future Work . . . . .	137
6.2.1	Hopper Popper Activation (Hand Popper) . . . . .	137
6.2.2	LED Darts (eDarts) . . . . .	137

<b>A</b>	<b>Text Documents</b>	<b>139</b>
A.1	Hasbro Inc Corporate Quality Assurance Safety and Reliability Specification . . . . .	140
A.2	Raw Brainstorm Concept List . . . . .	153
<b>B</b>	<b>Figures</b>	<b>157</b>
B.1	30 Potential Concepts . . . . .	158
B.2	Final Hand Popper CAD . . . . .	173
B.3	Final eDart CAD . . . . .	175
<b>C</b>	<b>MATLab Documents</b>	<b>177</b>
C.1	Rocket Dart Mathematical Model . . . . .	178
C.2	Trajectory of Dart with Given Mass . . . . .	182
C.3	Maximizing Dart Distance with a Given Impact Diameter . . . . .	185
<b>D</b>	<b>Tabular Data</b>	<b>191</b>
D.1	String Shooter Data . . . . .	192
D.2	Hand Popper Force Data . . . . .	193
D.3	Hopper Popper Ball Height Recordings . . . . .	194
D.4	Hand Popper Part Comparison . . . . .	195
D.5	Dart Mass Data . . . . .	196



# List of Figures

1-1	Final Iteration of the Hand Popper . . . . .	20
1-2	Operational Force Comparison . . . . .	20
1-3	The Final eDart . . . . .	21
1-4	Standard and eDart Trajectories . . . . .	22
2-1	Overview of Super Soaker <sup>®</sup> and Nerf <sup>®</sup> Product History . . . . .	28
3-1	High Potential Concepts . . . . .	34
3-2	High Potential Concepts Continued . . . . .	35
3-3	Three Tier Hierarchy of Preferred Concepts . . . . .	38
3-4	Conceptual Drawing of a Handheld String Shooter . . . . .	39
3-5	The String Shooter Sketch Model . . . . .	40
3-6	Distances Achieved for Various Projectiles using the String Shooter . . . . .	41
3-7	Streamline of Air Exiting Balloon . . . . .	42
3-8	The Rocket Dart Sketch Model . . . . .	43
3-9	Trajectory of Rocket Dart with and without Self-Propulsion . . . . .	44
3-10	A Variety of Misting Nozzles . . . . .	46
3-11	Photograph of a Fountain creating the Water Worm Effect . . . . .	48
3-12	The Water Worm Shooter Sketch Model . . . . .	49
3-13	Components of the Water Ball Launcher Sketch Model . . . . .	50
3-14	The Hopper Popper in the Natural and Inverted State . . . . .	52
3-15	Foam Ball Resting in an Inverted Hopper Popper . . . . .	53
3-16	Cross Section of the Popper Holder . . . . .	53
3-17	The Hopper Popper Holder . . . . .	54

3-18 Hopper Popper Implemented into the Atom Blaster™ . . . . .	54
3-19 The Hopper Popper Implemented into the Zero Toys® Products . . . . .	55
3-20 The Trigger Activated Post-Pickup Sketch Model . . . . .	55
3-21 The Blow-Dart-Like Post-Pickup Sketch Model . . . . .	56
3-22 Retainer Ring Used in the Atom Blaster™ . . . . .	56
3-23 The Redesigned Holder Incorporating Rubber Tabs . . . . .	57
3-24 Concept Drawings of the Hand Popper . . . . .	58
3-25 The Hand Popper Sketch Model . . . . .	58
3-26 Concept Sketch of Stomp Grenade . . . . .	59
3-27 Refined Popper Holder . . . . .	59
3-28 The Stomp Grenade Sketch Model . . . . .	60
3-29 Concept Sketch of LED Dart . . . . .	61
3-30 The General Circuit for the LED Dart . . . . .	62
3-31 The Optimized Circuit for the LED Dart Sketch Model . . . . .	64
3-32 The Electronic Components of the LED Dart Sketch Model . . . . .	65
3-33 The Assembled LED Dart Sketch Model . . . . .	66
3-34 The Nerf® PowerClip™ . . . . .	66
3-35 The Modified Clip with Shim Stock Contacts . . . . .	67
3-36 The LED Dart Sketch Model . . . . .	67
4-1 Alternative Inner Geometries of the Popper Holder . . . . .	70
4-2 SLS Prototyped Popper Holder . . . . .	70
4-3 SLA Prototyped Stomp Grenade Body . . . . .	71
4-4 Press-Fit Delrin Support . . . . .	71
4-5 The Assembled Stomp Grenade . . . . .	72
4-6 Model of a Grenade with Timer Mechanism . . . . .	73
4-7 Customized Drive Assembly in SLS Housing for the RC Grenade . . . . .	74
4-8 The Assembled RC Grenade . . . . .	75
4-9 Trigger Pushing the Side of an Inverted Popper . . . . .	76
4-10 Foam and SLA Versions of the Hand Popper Backing Plate . . . . .	77

4-11 1st Iteration of the Hand Popper . . . . .	78
4-12 Bump Located in the Backing Plate . . . . .	79
4-13 Adjustable Ball-End Set Screw . . . . .	79
4-14 2nd Iteration of the Hand Popper with Flared Channel . . . . .	80
4-15 2nd Iteration of the Hand Popper with Cylindrical Channel . . . . .	80
4-16 Average Loading Forces for Various Popper Scenarios . . . . .	82
4-17 Average Operational Force Comparison . . . . .	83
4-18 Average Triggering Force Comparison . . . . .	84
4-19 Hole Patterns Created in Poppers . . . . .	85
4-20 High Speed Photography of the Popper Accelerating Vertically . . . . .	86
4-21 High Speed Photography of an Unconstrained Popper Launching a Foam Ball . . . . .	87
4-22 High Speed Photography of a Constrained Popper Launching a Foam Ball . . . . .	87
4-23 Residual Markings from Impact Testing . . . . .	88
4-24 Motion Path of Popper . . . . .	89
4-25 Means of Inverting Popper with Less Force . . . . .	90
4-26 Fingers Guided on a Track . . . . .	90
4-27 Loading Motion of a Cross-Sectioned Unconstrained Holder . . . . .	91
4-28 The Unconstrained Popper Mechanism . . . . .	92
4-29 Wax Mold Used to Create an Elastic Holder . . . . .	92
4-30 CAD Cross-Section of the Casted Silicone Ring . . . . .	93
4-31 The Elastically Constrained Popper . . . . .	94
4-32 Rubber Skirt Extending from the Popper Rim . . . . .	95
4-33 High Friction Areas inside the Popper Holder . . . . .	95
4-34 Operational Force Comparison . . . . .	96
4-35 Vertical Distances Achieved by Foam Ball Launched with Various Mech- anisms . . . . .	97
4-36 Adjusting the Trigger/Popper Contact Location . . . . .	97
4-37 Redesigned Back Plate . . . . .	98

4-38	Final Iteration of the Hand Popper . . . . .	98
4-39	Number of Parts Comparison . . . . .	99
4-40	The Nerf <sup>®</sup> Ball Blaster <sup>™</sup> . . . . .	101
4-41	Hopper Popper Activation Evolution . . . . .	102
5-1	Various Dart Contact Layouts . . . . .	104
5-2	Redesigned Circuit with Two Blaster-Side Contacts . . . . .	105
5-3	Revised Dart Component Layout . . . . .	107
5-4	Painted Exterior Dart-Side Contacts . . . . .	107
5-5	Two Contacts on the Blaster Side . . . . .	108
5-6	Final 1st Iteration Clip . . . . .	108
5-7	Standard 1/8 <i>in</i> Stereo Plug . . . . .	110
5-8	Revised Contact Orientation . . . . .	110
5-9	Wire Contact for Dart Insert . . . . .	111
5-10	Shim Stock Contacts for Dart Insert . . . . .	111
5-11	Contact Component for Back Illuminating Dart . . . . .	112
5-12	Final Back Illuminating Dart . . . . .	113
5-13	Shim Stock Switch for Impact Dart . . . . .	113
5-14	Impact Dart Circuit . . . . .	114
5-15	Final Impact Dart Insert . . . . .	114
5-16	Contact Component for Front Illuminating Dart . . . . .	115
5-17	Final Front Illuminating Dart . . . . .	116
5-18	Contact Component for Alternating Color Blinking Dart . . . . .	116
5-19	Securing the Electronics Inside the Dart Body . . . . .	117
5-20	Modifications to the Magazine . . . . .	118
5-21	Redesigned Blaster Post . . . . .	118
5-22	2nd Iteration Blaster . . . . .	119
5-23	Dart Contact Bridging Blaster Contacts . . . . .	119
5-24	DC Power Connection . . . . .	120
5-25	2nd Iteration Dart Mass Comparison . . . . .	120

5-26 Dart Component Mass Contribution . . . . .	121
5-27 Trajectories of Standard Dart and 2nd Iteration Darts . . . . .	121
5-28 Maximum Allowable Trajectories of Standard Dart and 2nd Iteration eDarts . . . . .	122
5-29 Standard and High Resilience Dart Impact Markings . . . . .	122
5-30 Effect of Changing the Impact Area for Standard Dart and 2nd Itera- tion Darts . . . . .	123
5-31 Final Circuit Design . . . . .	125
5-32 Final Circuit . . . . .	126
5-33 The Final eDart . . . . .	126
5-34 Final eDart Components . . . . .	127
5-35 Dart Mass Comparison . . . . .	127
5-36 Standard and eDart Trajectories . . . . .	128
5-37 PowerClip™ Pressure Release Mechanism . . . . .	129
5-38 Piston Pump with Four One-Way Valves . . . . .	130
5-39 Comparison of Dart Component Mass Contribution . . . . .	131
5-40 Maximum Allowable Distances of Final eDart and Standard Dart . .	132
6-1 Final Hand Popper Iteration . . . . .	136
6-2 Final eDart Cross Section . . . . .	137





# List of Tables

3.1 Misting Nozzle Properties . . . . .	46
---	----



# Chapter 1

## Introduction

### 1.1 Objective

The goal of this research was to apply the product design process to develop new projectile toy technologies. The developed products were required to fit within one of Hasbro<sup>®</sup>'s current lines of projectile toys; Nerf<sup>®</sup> and Super Soaker<sup>®</sup>. Nerf<sup>®</sup> is a product line which incorporates foam plastic and Super Soaker<sup>®</sup> is a product line which involves high performance pressurized water guns. The products were required to meet all safety specifications and regulations provided by the sponsor company Hasbro<sup>®</sup> Incorporated. An emphasis was placed on the development of a technology that was capable of being applied to a variety of toys.

### 1.2 Outcomes

The team reduced an initial group of over 100 concepts to 30 potential concepts. Six high potential concepts were prototyped with a sketch model: String Shooter, Rocket Darts, Mist Blaster, Water Blobs, Foam Grenade, and LED Darts. The Foam Grenade concept evolved into a more general concept of Hopper Popper Activation which involved a bi-stable rubber spring capable of projecting foam balls. The Hopper Popper Activation and LED Darts, being the most promising, advanced to a detailed design stage.

## 1.2.1 Hopper Popper Activation (Hand Popper)

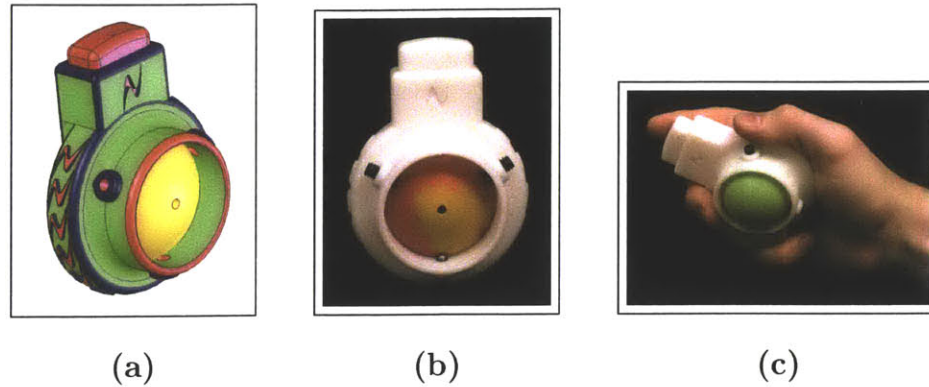

Figure 1-1: Final Iteration of the Hand Popper

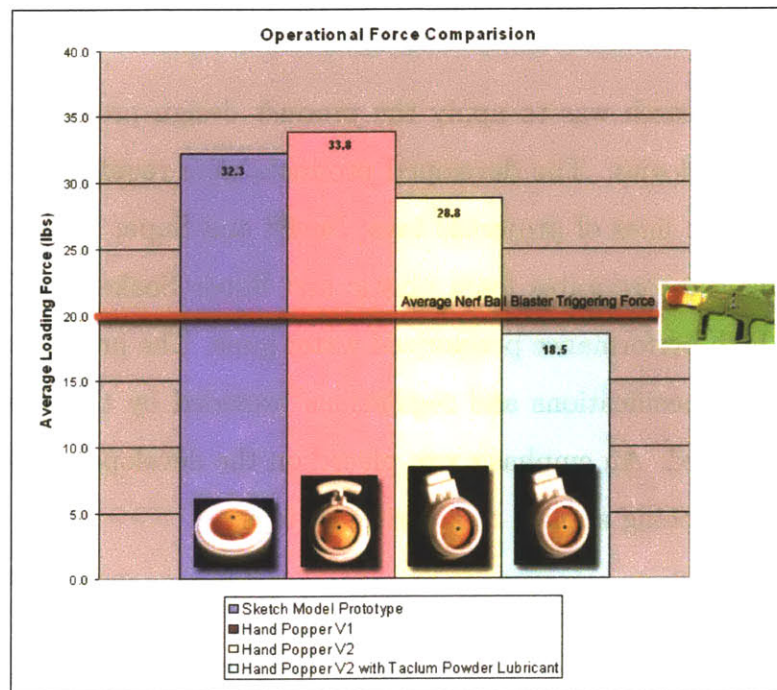

Figure 1-2: Operational Force Comparison

In the Detailed Design phase, the Hopper Popper Application was applied to two iterations of a Hand Popper, a small hand-held toy capable of launching foam balls, as well as two versions of a Foam Grenade. The sponsor showed a greater interest in the Hand Popper over the Foam Grenade. The greatest issue of concern was the force required to load the popper. After testing several means of lowering the loading

force, a low friction design, shown in Figure 1-1 was chosen for the final iteration of the Hand Popper. This final iteration required an average of 18.5 *lbs* of force to load, which was less than the operating force on firing of the state of the art devices. This is shown in Figure 1-2. The final iteration was capable of projecting a foam ball 20% further than the state of the art. The Hand Popper was determined to be a successful projectile toy meeting all requirements presented by the sponsor.

### 1.2.2 LED Darts (eDarts)

In the detailed design phase, the LED Dart concept evolved through two iterations, both in attempt to provide for axially symmetric loading. The first iteration involving conductive film/paint contacts did not meet expectations. The second iteration using a 1/8 *in* stereo plug on the blaster post and a customized jack in the eDart body was highly successful. Four versions of eDarts were developed: Back Illuminating, Impact, Front Illuminating, and Alternating Color Blinking. The mass of the eDart was the greatest issue of concern with this second iteration.

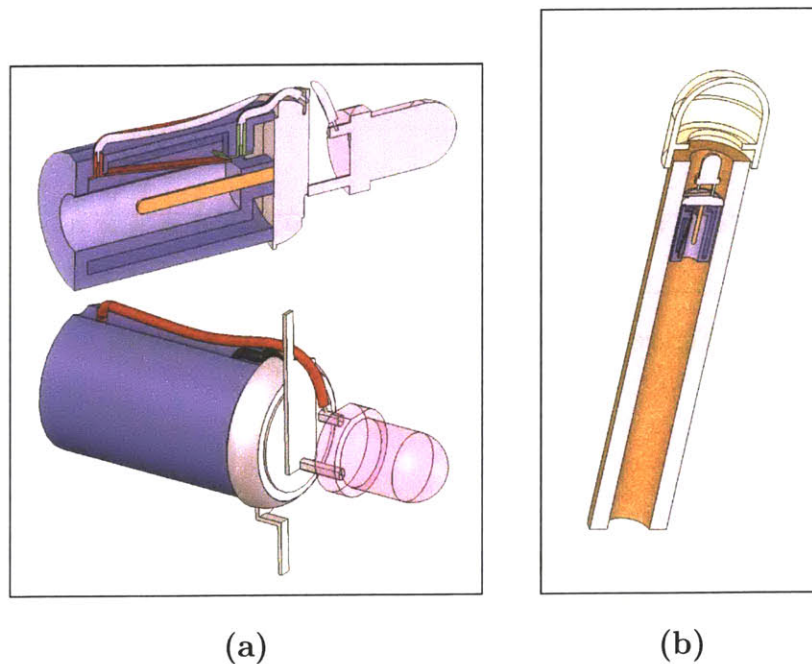

Figure 1-3: The Final eDart

The final design, shown in Figure 1-3 implemented a simple mechanical switch,

which allowed for fewer and lighter dart circuit components. The mass of this final eDart was reduced to approximately 1.45 g. This is slightly greater than the mass of a standard foam dart being 1.25 g. The final design was capable of traveling 19 m when fired at 35 degrees from a PowerClip™ elevated 1.5 m off the ground. This trajectory as compared to the standard dart trajectory is shown in Figure 1-4. Implementing a resilient cap with an impact diameter of 20 mm, the eDart was allowed to travel up to 33 m to remain under the Kinetic Energy Density limit. Although not required, the blaster can be modified to allow the eDarts to reach this limit. The eDarts were very successful and the sponsor has begun their initial stages of manufacturing.

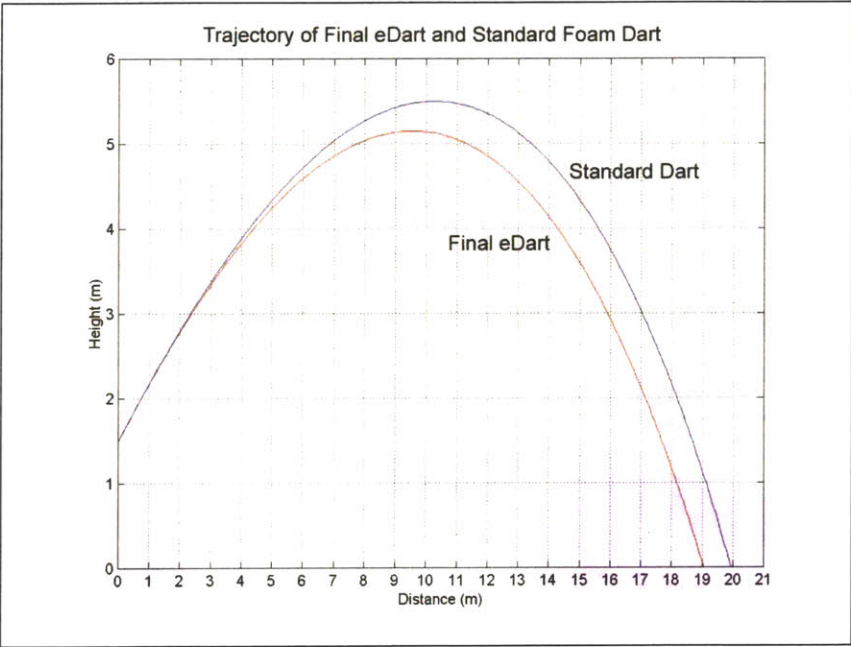

Figure 1-4: Standard and eDart Trajectories

### 1.3 About this Thesis

The team adapted a standard structured method of product design similar to those presented in the M.I.T Product Engineering Processes Course 2.009 and the Ulrich and Eppinger text Product Design and Development [11]. Structured methods reduce the possibility of moving forward with unsupported decisions, insure that all

important issues are included, and are self-documenting which aids in formatting and referencing. Some minor deviations were made in the standard structure to better accommodate the sponsor, designer, and subject matter. These deviations will become apparent later in the text.

There are four standard phases of product development addressed in this paper: Planning, Ideation, Detailed Design, and Testing and Refinement. The Planning section discusses the sponsor needs, the state of the art technology, and the standards and safety requirements. The Ideation section details the brainstorming and sketch model development. The Sketch Model section describes six high potential concepts: String Shooter, Rocket Darts, Mist Blaster, Water Blobs, Foam Grenade, and LED Darts. Hopper Popper Activation (a variant of the Foam Grenade) and the LED Darts were selected for further development.

Following the Ideation section, the paper is divided by concept to allow for a clear understanding of each concept progression. Each concept section is divided into the last two stages of product development: Detailed Design and Testing and Refinement.

The Hopper Popper Activation section was authored primarily by Barry Kudrowitz. In the Hopper Popper Activation Detailed Design, two applications are discussed: Hand Popper and Foam Grenade. A focus was placed on the Hand Popper in the Testing and Refinement Section. The Testing and Refinement Section is composed of the following sections: Understanding of the Popper, Means of Lowering the Loading Force, and the Final Hand Popper Iteration. The Final Hand Popper Iteration section covers the design, safety, manufacturing, and a comparison to the state of the art technology.

The LED Dart section was authored primarily by William Fienup. The LED Dart Detailed Design section discusses two iterations made on the LED Dart. The LED Dart Testing and Refinement section is divided into an eDart Analysis section and a Suggested Final Design section. The former explains the issues related to masses and distances. The latter recommends a final design and compares it to the state of the art.





# Chapter 2

## Planning

The planning phase precedes the actual product development process. This phase involves assessing the available technology and objectives, determining the sponsor needs, developing a mission statement, and thoroughly analyzing the state of the art. These steps allow the designers to become familiar with the subject matter and determine the opportunities in the market.

### 2.1 Customer Needs

Planning begins with identifying the consumers and their many needs and then using these needs to provide product specifications. In this design process, the sponsor, Hasbro<sup>®</sup>, had clearly defined their requirements as well as provided a list of specifications. The sponsor's needs were few and general, which broadened the scope and allowed for the development of a wide range of loosely related concepts. The specifications provided by Hasbro<sup>®</sup> are elaborated in the Standards and Safety section. For this endeavor, the sponsor was not the primary user; however, the needs of both the sponsor (Hasbro<sup>®</sup>) and the consumer (children) were taken into consideration at all stages of the design process.

The key sponsor needs provided by Hasbro<sup>®</sup> are as follows:

- The product is a projectile toy or a technology that can be applied to a projectile toy.

- The product fits within one of their current lines of projectile toys (Nerf<sup>®</sup> and Super Soaker<sup>®</sup>).
- The product is safe and meets all safety specifications and regulations provided in the Standards and Safety section.

A final sponsor need involved the nature of the development project. According to Ulrich and Eppinger [11], there are four types of product development projects :

- New product platforms involve creating a new family of products based on a common platform.
- Derivatives of existing product platforms extend an existing product platform to address different needs.
- Incremental improvements to existing products are slight changes to enhance or eliminate flaws.
- Fundamentally new products are radically different products or production technologies to address new or unfamiliar markets, usually at a high risk.

The sponsor emphasized the highest priority to be the development of a technology that can be applied to create a new product platform (within the overall Nerf<sup>®</sup> or Super Soaker<sup>®</sup> line). The sponsor was open to fundamentally new products and derivatives of existing product platforms. The sponsor, however, discouraged projects of incremental improvement to existing products. These preferences were taken into account during brainstorming sessions.

Using the sponsor needs, the following mission statement was developed to guide the team through the process:

**To design and develop safe, innovative, projectile toys that fit within the line of Nerf<sup>®</sup> or Super Soaker<sup>®</sup>**

## 2.2 State of the Art

The MIT environment presents many opportunities for exploration of ideas. The team investigated the current research in such labs as the Hatsopoulos Fluids Lab and the Precision Engineering Research Group for possible applicable emerging technologies.

The team made frequent visits to toy stores (Toys “R” Us<sup>®</sup>, Kay-Bee Toys<sup>®</sup>, Spencer’s Gifts<sup>®</sup>, etc.) and local toy manufacturers (Hasbro<sup>®</sup>, Zero Toys<sup>®</sup>) to become acquainted with the state of the art technology. At Hasbro<sup>®</sup>, the team met with current toy developers (including engineers, industrial designers, and marketing representatives) and attended official brainstorming sessions to become familiar with the toy design process.

The team performed general toy patent searches and reviewed the detailed listings and specifications of the complete line of Nerf<sup>®</sup> and Super Soaker<sup>®</sup> Brand products. Nerf<sup>®</sup> and Super Soaker<sup>®</sup> are projectile toys developed by the “Big Kids” division of Hasbro<sup>®</sup>. Nerf<sup>®</sup>, developed in 1969 as an indoor safe ball, can be described as a line of projectile toys that involve foam plastics, such as dart launchers, foam ball launchers, and sports equipment. Super Soaker<sup>®</sup>, dating back to 1982, describes a line of high performance pressurized water guns [5].

Figure 2-1 is a condensed overview of the breakthrough Nerf<sup>®</sup> and Super Soaker<sup>®</sup> products over the years [7] [4].

Nerf<sup>®</sup> products have evolved from the original plunger and spring launching mechanisms to the contemporary Constant Pressure System (CPS) powered products. A few Nerf<sup>®</sup> products are motorized, such as the Nerf<sup>®</sup> Ballzooka<sup>™</sup>. Most of the improvements in Nerf<sup>®</sup> and Super Soaker<sup>®</sup> design, however, have been derivatives of existing product platforms or incremental improvements on existing products.

The team researched some projectile toys outside of the Hasbro<sup>®</sup> line such as the AirZooka<sup>™</sup> and Zero Blaster<sup>™</sup>. These products propel toroid vortices of air or air/smoke mixture. These products do not clearly fit into the line of Nerf<sup>®</sup> or Super Soaker<sup>®</sup>; however, the technology is referenced later in the Ideation section of this paper.



Super Soaker<sup>®</sup> 50 (1993). This was the first water gun on the market to fire water using stored air pressure.



Super Soaker<sup>®</sup> 100 (1993). This water gun utilized a pressure chamber separated from the water supply.



Super Soaker<sup>®</sup> CPS 2000 (1997). Utilizing a CPS bladder, the blaster always fired at a maximum strength.

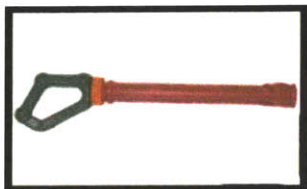

Nerf<sup>®</sup> Blast-A-Ball<sup>™</sup> (1989). This was the first Nerf<sup>®</sup> product to fire foam balls.



Nerf<sup>®</sup> Bow 'n' Arrow (1990). This was the first Nerf<sup>®</sup> product to feature new ammunition: the foam arrow.



Nerf<sup>®</sup> Sharpshooter (1992). This was the first dart firing Nerf<sup>®</sup> blaster utilizing a spring activated plunger.



Nerf<sup>®</sup> Arrowstorm<sup>™</sup> (1993). This was the first Nerf<sup>®</sup> product to feature an automatically rotating barrel for rapid fire.



Nerf<sup>®</sup> SuperMAXX<sup>™</sup> (1997). This was the first line of Nerf<sup>®</sup> products to utilize stored air pressure.



Nerf<sup>®</sup> WildFire<sup>™</sup> (1999). This was the first fully automatic Nerf<sup>®</sup> blaster.



Nerf<sup>®</sup> Ball Blaster<sup>™</sup> (1999). This is the current foam ball blaster on the market.



Nerf<sup>®</sup> PowerClip<sup>™</sup> (1999). This is a more compact redesign of the Nerf<sup>®</sup> WildFire<sup>™</sup>.

Figure 2-1: Overview of Super Soaker<sup>®</sup> and Nerf<sup>®</sup> Product History

## 2.3 Standards and Safety

In designing projectile toys, standards are needed to minimize any potential for injury (especially eye injury), while maintaining the traditional (or expected) play value of the toy. The sponsor provided a detailed listing of all safety specifications for projectiles in a document entitled, “Corporate Quality Assurance, Safety and Reliability Specification, SRS-045, Projectiles” [1]. This document addresses the various structural characteristics and kinetic parameters of projectiles used on Hasbro® products. Only applicable clauses of this document will be referred to in this Standards and Safety section. The full Safety and Reliability Specifications can be found in Appendix A.

The scope of the research is limited to toys that are intended to launch projectiles by means of a discharge mechanism in which the kinetic energy of the projectile is determined by the toy and not the consumer. This refers to toys that are capable of storing and releasing energy under the control of the operator. Projectiles without stored energy (propelled solely by the energy of the consumer) were considered outside of the scope. It is assumed that all projectile guns are to be operated by children, ages five years and up.

The following are brief summaries of the applicable safety specifications provided by Hasbro® which have influenced the design process.

### **Improvised Projectile Testing**

The discharge mechanism must not be capable of discharging projectiles other than the projectile specifically designed for use with that mechanism. The following is a list of the more common hazardous improvised projectiles: pens, pen caps, pen refills, markers, marker caps, paperclips, batteries, marbles, and pebbles. Additional information and dimensions of these products can be found in Appendix A.

### **Projectile Configuration Evaluation**

Projectiles with protrusions such as ribs or fins that extend outward from the main body must meet Hasbro® safety requirements. Protrusions that are not “blended” to the body cannot be over  $3/16$  in and subtend an angle of 30-90 degrees from the

body. All projectile configurations, however, must be approved by Quality Assurance.

### **Impact Test for Projectiles**

Projectiles must withstand an impact test without generating a hazardous condition or reducing the integrity of the projectile. This impact test involves discharging the projectile six times into a concrete block wall at a distance of one foot plus the length of the projectile from the end of the discharge mechanism. The discharge mechanism must be perpendicular to the test wall.

### **Unexpected Discharging of Projectiles**

Projectiles must not be discharged in an unexpected manner. The projectile must discharge within four seconds of user activation.

### **Sharp Edges**

Projectiles must not have sharp edges or sharp points. Sharp edges and points are defined by Hasbro<sup>®</sup> Documents SRS-003 and SRS-002.

### **Projectile Tip**

The tip is the portion of the projectile that is expected to contact an impact surface during flight. Tips are usually the leading edge of the projectile; however, in the case of a Frisbee or disk the circumferential edge is considered the “tip.”

Projectiles must have a tip radius greater than 2 *mm* (.08 *in*). The minimum allowable tip radius increases in direct proportion to the kinetic energy of the projectile as can be found in Appendix A. Tips must not be able to detach from the projectile when subjected to a torque test of 8 *in.lbs* or a tension test of 20.5 *lbs*. Tips must not detach to reveal hazardous points or edges.

### **Kinetic Energy and Kinetic Energy Density**

Projectiles fired from a toy with a kinetic energy exceeding .08 *Joules* must have an impact surface (tip) of a resilient material. Resilient tips have a Shore A durometer rating that is under 55. The Kinetic Energy Density (KED) must be determined for all projectiles exceeding a kinetic energy of .08 *Joules*. The Kinetic Energy Density (expressed in *Joules/area*) is the kinetic energy of the projectile divided by its contact area. The Kinetic Energy Density of a projectile must not exceed 1600 *J/m<sup>2</sup>*.

# Chapter 3

## Ideation

### 3.1 Introduction

This section describes the processes used to develop concepts and determine which were best suited for further development. Brainstorming techniques were used to generate over 100 original projectile toy concepts. Narrowing the concepts involved several methods. The initial reduction from over 100 concepts to 30 potential concepts involved intuition and multivoting. Concept drawings were developed for these 30 and the sponsor chose twelve concepts worthy of further development. The sponsor ranked these twelve concepts into three tiers of importance and provided feedback for concept improvement. The team physically and analytically prototyped the highest tiered concepts with sketch models. These concepts included: String Shooter, Rocket Darts, Mist Blaster, Water Blobs, Foam Grenade, and LED Darts. The concepts of the Hopper Popper Activation (a variant of the Foam Grenade) and LED Darts had the greatest potential as agreed on by the sponsor and the design team and were selected for further development.

### 3.2 Brainstorming

Brainstorming is the most common method for generating conceptual designs. Individual and group brainstorming sessions are critical for building consensus, commu-



nicating information, and refining concepts. Two brainstorming sessions were held to generate concepts. The first was a more internal and private session between the two members of the team, William Fienup and Barry Kudrowitz. Approximately fifty concepts were generated and many of these appeared again in the second session. The second brainstorming session involved more planning and structure. Essentially, there are no standard rules in brainstorming; however, a suggested format proposed by Slocum [9] referencing Pahl and Beitz [8] was loosely followed for this session.

Brainstorming groups should be composed of a minimum of five members to insure a significant amount of views, opinions, and therefore, concepts. A group should also be limited to fifteen members to avoid segmentation within the group. The organized group contained seven members: Barry Kudrowitz, William Fienup, Tim Vanderpoel, Amy Banzaert, Professor David Wallace, Professor Alex Slocum, and Professor Woody Flowers.

The group should be composed of experts from a variety of fields to ensure a sufficient representation of technology. Usually a few laypeople should be involved in the session. The session contained experts in all areas of product design and development including a current toy designer and several product design instructors.

A leader should be appointed to organize, take notes, ensure that all subtle comments are recorded, and to keep the group on track within the bounds of the mission statement. In this session Barry Kudrowitz acted as leader and recorded all concepts proposed by the group.

Some additional guidelines suggested by Slocum were also regarded. All participants must be able to speak freely without fear of being subjected to harassment. No ideas are to be considered “silly” or discarded as infeasible, as these irrelevant or fanciful ideas may lead to plausible concepts. Criticism is suggested, but to be constructive and kept to a minimum. All ideas must be recorded for later review. Finally, sessions should not last longer than 30 to 45 minutes as people tend to become less productive.

The format of the second session involved all members freely sketching concepts and assigning a name to each concept. The members then proposed the concept to

the group and the group leader recorded the concept title with a brief description. Appendix A contains a listing of the 111 original concepts generated from these brainstorming sessions. Each concept is composed of a title and a short description. The concepts are listed alphabetically. Please note that the term “blaster” is used in this paper in place of “gun” to avoid a hazardous association.

### **3.2.1 Distilling to 30 High Potential Concepts**

The initial reduction from over 100 original concepts to 30 potential concepts involved intuition and multivoting. Multivoting is the process in which each member of the team votes for several concepts and those concepts with the most votes move on to a secondary analysis. The highest ranked concepts presented in this section were those which best reflected the mission statement, met the sponsor needs, and/or seemed highly innovative. In some instances, similar original concepts were combined into a slightly more general all-encompassing concept.

Figures 3-1 and 3-2 are a listing of the top 30 high potential concepts chosen by the team to be presented to the sponsor for review. These concepts are listed in alphabetical order to avoid a presentation bias. Large figures with captions can be found in Appendix B.

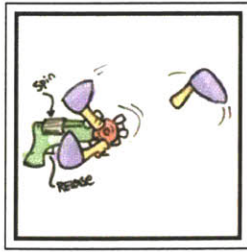

Axe Thrower

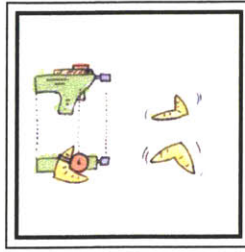

Boomerang Launcher

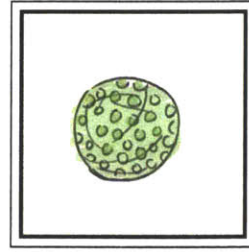

Dimpled Foam Ball

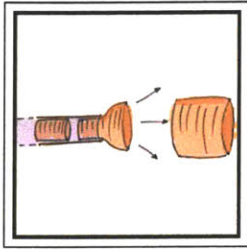

Enlarging Ammo

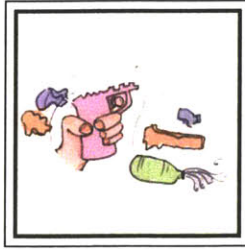

Fall-Apart Blaster

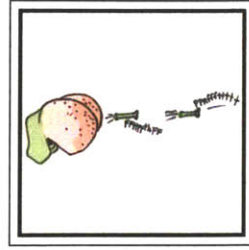

Fart Darts

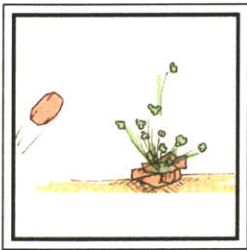

Foam Grenade

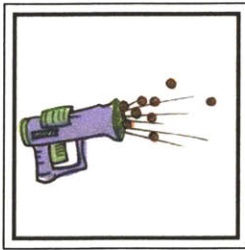

Foam Shotgun

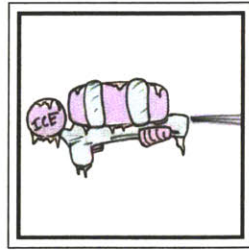

Freeze Blaster

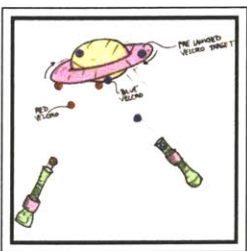

Kid Skeet Game

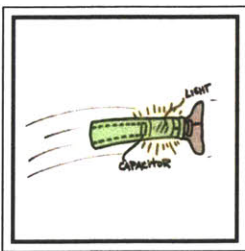

LED Darts

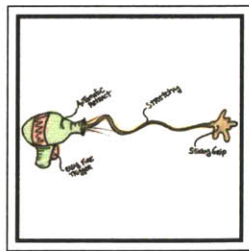

Lizard Tongue



Matrix Darts

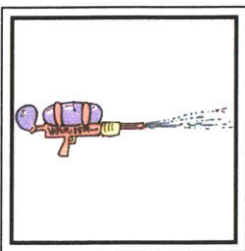

Mist Blaster

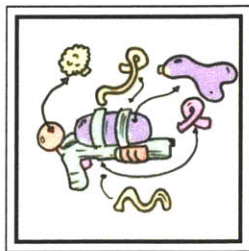

MrPotatoSoaker

Figure 3-1: High Potential Concepts

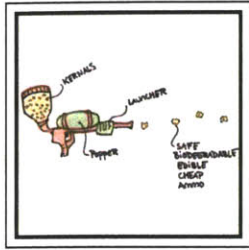

Popcorn Blaster

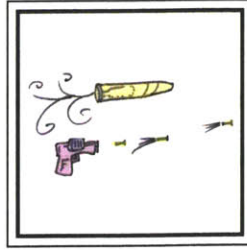

Rocket Darts

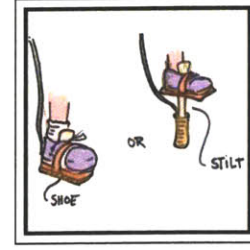

Shoe Pump

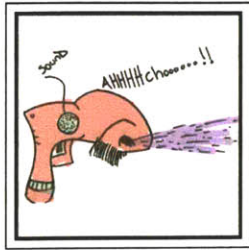

Sneeze Blaster

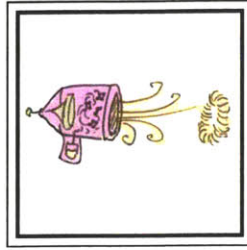

Sound/Scent-Zooka

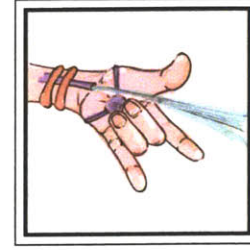

Spiderman Soaker

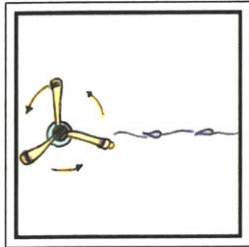

Spinning Sling

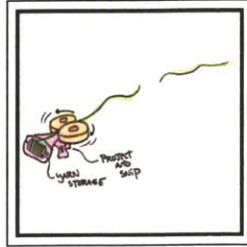

String Shooter

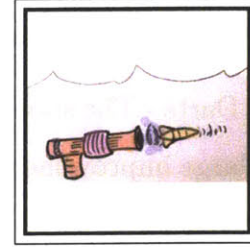

Torpedo Blaster

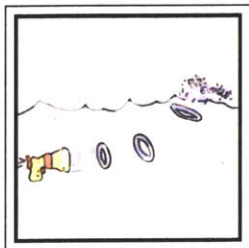

Underwater Bubble



Wall Mounting

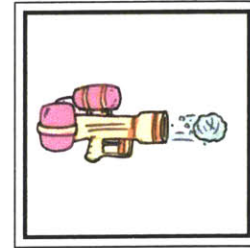

Water Ball

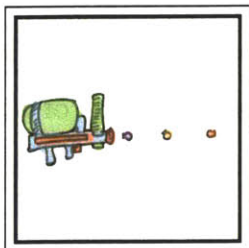

WaterBalloon Blaster

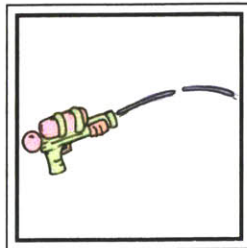

Water Worm

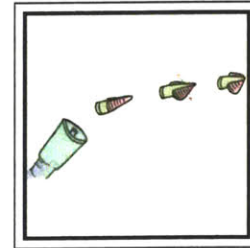

Wingman

Figure 3-2: High Potential Concepts Continued

### 3.2.2 Ranking and Focusing

The team presented the 30 potential concept sketches to the sponsor and explained the benefits of each concept. The sponsor then commented on each concept, discarded some concepts, and placed the remaining concepts into a three tier hierarchy of preference as shown in Figure 3-3.

In the first tier, the sponsor placed those concepts which they felt deserved immediate prototyping and further development. First tier concepts are as follows:

- Mist/Snow Blaster - The sponsor was interested in having a Super Soaker® product that can be used off season. Their current Super Soaker® products are inherently seasonal toys.
- Axe Thrower - The sponsor was interested in a “throwing” mechanism and experimenting with new Nerf® ammunition shapes.
- LED Darts - The sponsor expressed a great interest in this concept as this would be a large improvement over the glow-in-the-dark darts, the current product for nighttime play.
- Rocket Darts / Fart Darts / Matrix Darts - The sponsor grouped these products as they all combined an element of adjusting the manner of which the darts fly. The team also suggested that these concepts could all involve an internal bladder.
- String Shooter - Although this product does not fit within the line of Nerf®, the sponsor felt that this concept deserved immediate prototyping. They also suggested a licorice rope launcher.
- Water Worm Shooter / Spinning Sling / Water Ball Launcher - The sponsor grouped these concepts as they all involved propelling a “chunk” of water. They showed a great interest in these concepts as they had been prototyping similar ideas.

In the second tier, the sponsor placed those concepts which they felt worthy of prototyping and further development, but with a lesser priority. Second tier concepts

are as follows:

- Kid Skeet - The sponsor showed interest in a Nerf® game, but showed more interest in a hovering Nerf® toy.
- Foam Grenade - The sponsor expressed a great interest in this concept, however, they stressed the safety issues presented by a toy of this nature.
- Shoe Pump / Stilt Power - The sponsor expressed interest in a new means of pumping and also suggested a pogo stick pump.
- Enlarging Ammunition - The sponsor stressed the aspect of quick loading and to avoid consumable ammunition if this concept was prototyped.

In the third tier, the sponsor placed the concepts of interest in which further development was not highly desired. Third tier concepts are as follows:

- Lizard Tongue - The sponsor believed this to be a “novelty” item, but, none the less, intriguing as an innovative projectile toy.
- Dimpled Foam Ball - The sponsor viewed this concept as a means to teach pitching technique by harnessing its directional capabilities.

A large number of concepts placed in the first two tiers can be considered platform concepts. These concepts present a technology which the sponsor could apply to a wide variety of different products. Many of the 30 high priority concepts which the sponsor discarded were termed “novelty” or only applicable for one product (Sneeze Blaster, Spiderman Soaker, Fall Apart Blaster, Mr. PotatoSoaker, Popcorn Blaster, Boomerang Gun). Some of the other discarded concepts, the sponsor determined to be inappropriate within the line of Nerf® or Super Soaker® (Underwater Bubble Ring, Sound Cannon / Scent-Zooka, Torpedo Blaster).

Having the sponsor’s preferences in mind, the team began a second stage of ideation.

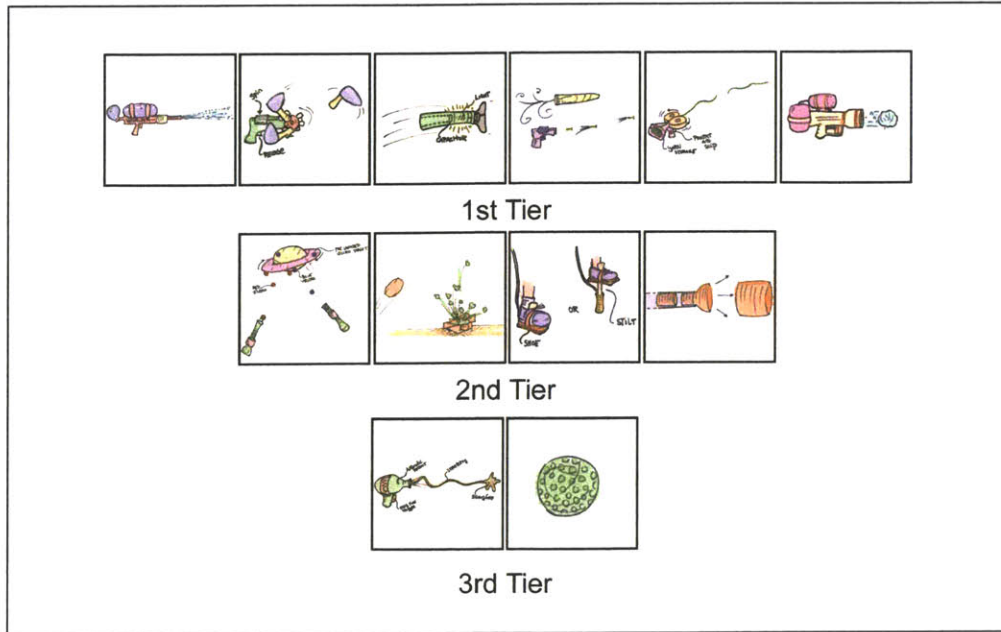

Figure 3-3: Three Tier Hierarchy of Preferred Concepts

### 3.3 Sketch Models

A prototype can be defined as any entity exhibiting at least one aspect of the product that is of interest to the development team. Prototypes can include: Physical prototypes which are models that look and feel like the product, proof-of-concept prototypes which are those used to test an idea quickly, and analytical prototypes which represent the product in a non-tangible, usually mathematical, manner. The majority of the sketch model prototypes were proof-of-concept or “works-like” models, as the team needed to first focus the research and determine which concepts were worth pursuing. This section describes the development of the sketch models used to test the following high-tier concepts: String Shooter, Rocket Darts, Mist Blaster, Water Blobs, Foam Grenade, and LED Darts.

#### 3.3.1 String Shooter

The String Shooter concept described a device that can propel string a relatively far distance (over 20 *ft*). The original concept involved propelling a continuous spool of string, however, given the safety issues presented by the sponsor, the team opted to

design for determined lengths of string. A sketch model was developed to determine if a length of string (or like material) could be propelled over 20 *ft*.

The team determined that the simplest design to launch different diameter and lengths of strings would involve two oppositely spinning disks. A length of string would be fed between the disks where it would be accelerated and propelled. A conceptual drawing for a handheld version of this design is shown in Figure 3-4.

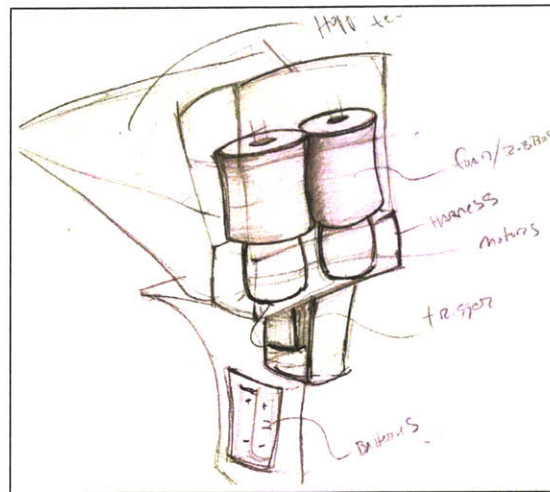

Figure 3-4: Conceptual Drawing of a Handheld String Shooter

The team first looked into the means of powering the disks. The team used high speed, low torque motors as it was assumed the string would not produce a high amount of resistance when passing between the disks. One motorized disk and one disk on a bearing could have been used in place of two motorized disks; however, the team felt the current design was comparable, less costly, and time efficient for a sketch model prototype. Before mounting the motors, the team had to determine what disks were to be used.

The team desired a disk material that would grip the string but also be compliant to adapt to different string diameters and materials. Soft closed-cell polyurethane foam was used to construct the disks. The foam was a 4 *in* OD, 1 *in* ID tube stock extrusion cut to 1 *in* thicknesses. A coupler was needed to join the foam rings to the motor shaft. The team formed couplers from a 1.25 *in* OD wooden dowel cut to .75 *in* segments. These cylindrical segments were press-fit into the foam rings.



The motors were then press-fit into a wooden block (1.5 in x 3.5 in x 12 in) with a 4 in space between motor shafts. At this distance, the foam disks touched and allowed for a slight compression on the projectile. A sheet of PVC plastic (14 in x 16 in) of .13 in thickness was heated and shaped around the wooden block and then reinforced with screws. The plastic was added to make the device more presentable and serve as an inclined guide for the string. The disks were then press-fit onto the motor shafts. The String Shooter sketch model is shown in Figure 3-5.

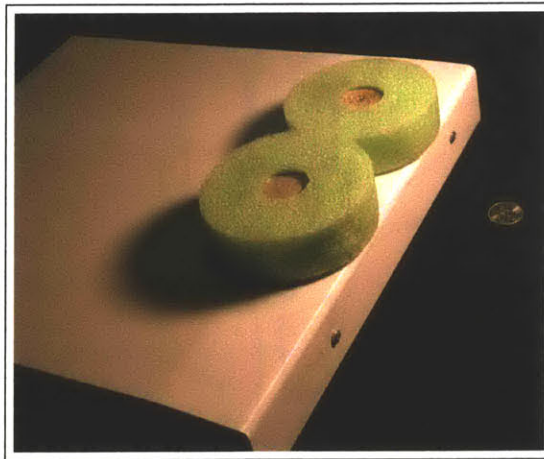

Figure 3-5: The String Shooter Sketch Model

Upon initial testing, the team found that the air currents generated behind the spinning disks prevented a string from being hand-fed between the disks. To overcome the air turbulence, the team fed the string through a one foot long aluminum tube with a .14 in ID and .155 in OD. Using this tube, the string could be properly aligned and launched.

Different material strings of different lengths and diameters were tested in the String Shooter. The three types of strings tested were as follows: yellow nylon string (.055 in diameter), plastic Glow String (.07 in diameter), and rubber string (.09 in diameter). The Glow String was of similar consistency and diameter to rope licorice, being a sponsor suggested application. Lengths of 12 in and 24 in were both tested. The longer string had a greater resistance and the tail end tended to be projected after the front end had decelerated resulting in a minimally projected mass of string.

Only the 12 *in* length string measurements were recorded in this testing. In addition to string, hazardous objects such as pens, pen caps, batteries, darts, and paperclips were projected by the String Shooter. All projectiles were launched at a 24 degree angle from the horizontal. Figure 3-6 is a chart of the average horizontal distances achieved by the different projectiles.

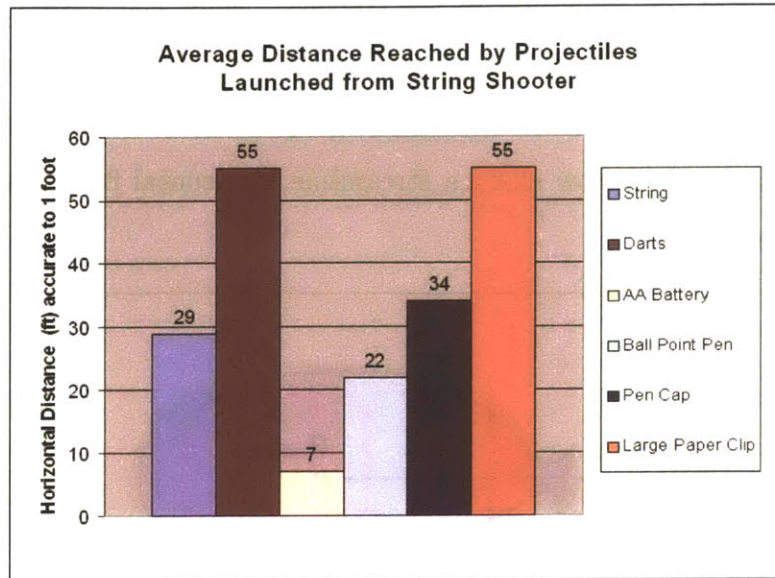

Figure 3-6: Distances Achieved for Various Projectiles using the String Shooter

Although capable of projecting string and darts a desirable distance, the String Shooter was also capable of projecting hazardous items an unsafe distance with unsafe velocities. It was determined that further design was needed to meet the safety requirements. In addition to safety issues, the disks produced an unpleasantly loud noise while in use. The sponsor showed interest in the concept, and in particular, its ability to launch darts, but ranked it lower in priority (than other prototypes) for further design.

### 3.3.2 Rocket Darts/Matrix Darts/Fart Darts

The concept of the rocket dart involved darts that appeared to maintain a constant height and velocity profile. These darts would propel themselves after the initial firing. This effect would be similar to that desired by the Matrix Darts or “Slow

Flying Darts,” thus the two concepts were grouped. The concept of the Fart Dart was not prototyped, but the design would be similar to the rocket dart with the addition of a reed element.

The team determined that a constant-pressure balloon was the optimal means of creating a self-propulsion system within a dart. An analytical prototype was first developed to insure the feasibility of the concept. With the illustration shown in Figure 3-7, the Bernoulli Equation was used to determine an exit velocity equation of the air leaving the dart. The following assumptions were made: inviscid, steady flow, incompressible flow, flow along a streamline, horizontal flow, and atmospheric pressure at balloon exit.

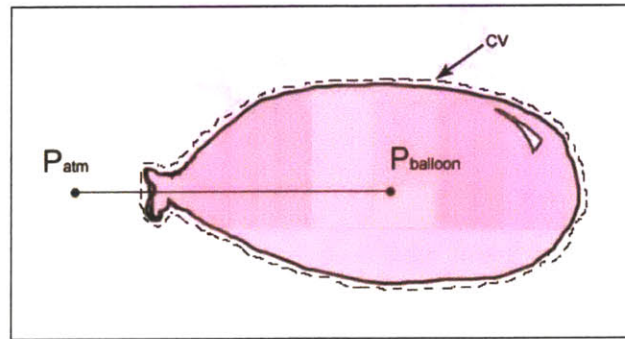

Figure 3-7: Streamline of Air Exiting Balloon

The exit velocity of the air escaping from the balloon,  $V_e$ , can be expressed by Equation (3.1), where  $P_b$  is the pressure inside the balloon,  $P_{atm}$  is atmospheric pressure, and  $\rho$  is the density of air [2]:

$$V_e = \sqrt{\frac{2 \cdot (P_b - P_{atm})}{\rho}} \quad (3.1)$$

A MATLAB program was created to model the path of a hypothetical Rocket Dart taking into account: thrust, horizontal form drag, vertical form drag, and weight. The MATLAB code can be found in Appendix C along with the constants and assumptions. The program modeled the balloon thrust as a constant value for given time governed by the amount of pressure in the balloon. The horizontal drag was modeled as that of a circular disk with a drag coefficient of 1.17. The vertical drag on a cylindrical

body varies with Reynolds number and thus velocity. The program accounted for this changing vertical drag coefficient. A Taylor series expansion was performed on the sum of forces to approximate the vertical and horizontal position over time of a Rocket Dart with given initial conditions. Various initial condition scenarios were tested supporting the development of a physical prototype.

To maximize distance, assuming a fixed launch height, the Rocket Dart was designed to maximize thrust. Thrust can be increased by increasing the exit velocity of the air escaping the balloon,  $V_e$ , or increasing the ratio of air supply to mass of dart. The exit velocity of air escaping the balloon,  $V_e$ , is increased by increasing the pressure inside the balloon. The ratio of air supply to mass of dart and the pressure inside the balloon were the two critical design parameters used to create the physical prototype.

The dart body was designed to be lightweight, but with sufficient room for a large supply of air. A sheet of thin transparent acrylic was wrapped around a foam nose cone and tail piece. This created a hollow dart that was approximately 3 *in* in diameter and 29 *in* in length. A stiff 260-balloon (commonly used to make balloon animals) was placed into the body of the dart as shown in Figure 3-8a. Three fins were added to the tail of the Rocket Dart for stability. The final Rocket Dart sketch model is shown in Figure 3-8b.



(a)

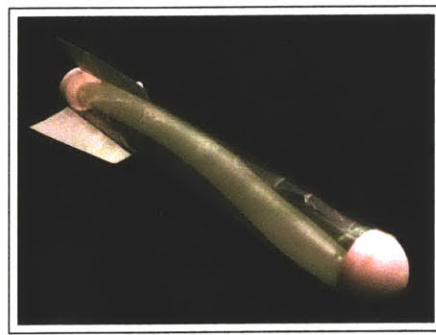

(b)

Figure 3-8: The Rocket Dart Sketch Model

Using values taken from the sketch model in the MATLAB program, a horizontally

thrown Rocket Dart with propulsion can hypothetically travel an additional 3 *m* further than the same dart thrown without self propulsion. This corresponds to a 60% increase in horizontal distance. Figure 3-9 shows the trajectory of the two hypothetical scenarios. The sketch model was successful and produced very similar results.

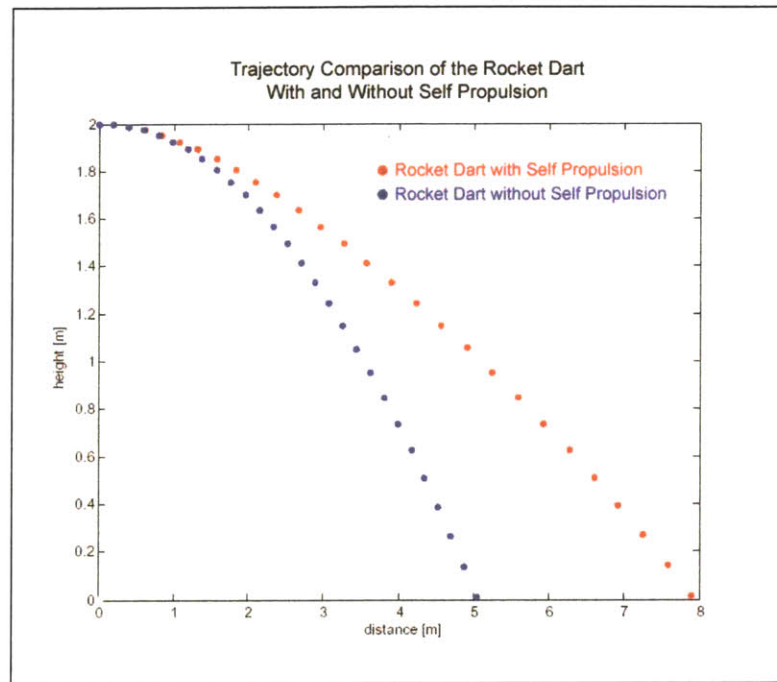

Figure 3-9: Trajectory of Rocket Dart with and without Self-Propulsion

This concept, however, was unfit for small standard foam darts, as the mass of the dart is several orders of magnitude larger than the amount of uncompressed air capable of being stored in a dart of that size. The sponsor was impressed with the Rocket Darts, but placed emphasis on other concepts.

### 3.3.3 Mist Blaster

The Mist Blaster concept involved spraying a fine cloud or jet of water droplets from a water gun. There are several advantages of this concept over the current Super Soaker<sup>®</sup> products. The Mist Blaster water supply lasts a significant amount of time longer, as the volumetric flow rate is considerably low. The Mist Blaster could

essentially be used indoors or on those who are less comfortable with being overly saturated. During winter months, the Mist Blaster (depending on conditions) could potentially produce a cloud of snow.

Background research was performed to determine if a “snow blaster Super Soaker®” was feasible. Current snow guns, found at ski resorts, produce snow by projecting super-cooled water with compressed air. This method is successful within a wide range of ambient conditions. A handheld Super Soaker® version would be similar to a common type of snow machine called an airless snow gun. These devices use simple nozzles (similar to the ones you find on household spray bottles) to atomize the water into a fine mist (100-700 *microns* in diameter). Airless snow guns are highly dependant on temperature and humidity. If the ambient temperature is approximately 30 F (-1 C), a fairly low relative humidity (less than 30 percent) is required for snow-making conditions. If the temperature is less than 20 F (-6.7 C), snow can form if the relative humidity is at 100 percent. An air temperature between 10 and 20 F is ideal for snow-making [3]. The process can be enhanced with the addition of a nucleator into the water supply. The water supply will already contain many forms of nucleators, but increasing the count ensures that more water droplets will freeze before they reach the ground. Aware of the feasibility, a sketch model was produced to test both the misting and snow making capabilities of a mist blaster.

In prototyping the Mist Blaster, the team first developed a looks-like model using an ultrasonic vibrator. These types of misters are commonly used in special effects and fountains. The team placed the ultrasonic vibrator submerged in water inside a PVC chamber. Two holes were placed in the chamber; one on the side to blow air in and one on the top for the mist to escape. The spray of mist generated was faint and unimpressive.

The team chose to prototype a works-like model with spray nozzles. Several different high quality ultra-fine misting nozzles were attached to a Super Soaker® (CPS 2500). These nozzles are shown in Figure 3-10. The nozzles produced a full cone spray of different angles and flow rates given by the Table 3.1. It was assumed the pressure of the Super Soaker® was approximately 20-30 psi.

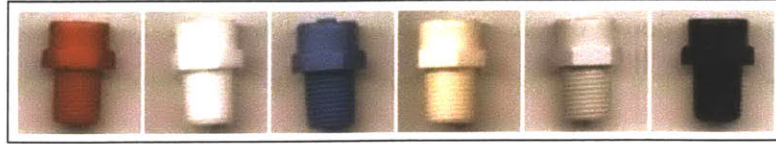

Figure 3-10: A Variety of Misting Nozzles

Table 3.1: Misting Nozzle Properties

Nozzle Color	Angle of Spray (degrees)	Flow Rate (L/min)
Cream	105	0.058
Blue	80	0.058
White	80	0.036
Gray	80	0.044
Black	120	0.11
Red	115	0.036

The resulting effect was less than impressive. The water droplets could not reach an adequate distance with the pressure provided by the current Super Soaker<sup>®</sup> bladders. A cloud of mist was produced but remained localized around the nozzle head. Nozzles with a larger flow rate could be used, but would result in a less mist-like effect. Outdoor weather conditions were not suitable for testing the snow-making application.

The team decided that this concept would best fit as a supplementary feature to a current Super Soaker<sup>®</sup>, creating a cloud of mist around the blaster and user. Its application as a winter toy is highly dependant on weather conditions and is not suitable for a product. The sponsor was supportive of this concept, but emphasized further development in other concepts.

### 3.3.4 Water “Chunks”

The Water “Chunk” concept involved projecting a cohesive section of water that maintained a clearly defined shape through the air. The Water Worm Shooter, the Water Ball Launcher, and the Spinning Sling constitute this general Water “Chunk” Concept. This section details the prototyping and background research behind the

Water Worm Shooter and the Water Ball Launcher. The Spinning Sling concept is discussed in this section; however, a bench level prototype was not created.

A water “chunk” has several advantages over the current water streams produced by the line of Super Soaker®. The visual appearance of a glassy airborne liquid mass is one of the most significant advantages. Having a clearly defined segment of water creates the illusion of a solid projectile. A water “chunk” can achieve great distances, as a coherent laminar segment has low turbulence, and therefore less drag. In addition, a coherent water stream is capable of transmitting light through internal refraction. A coherent water stream can also be cut to desired lengths.

### **Water Worm Shooter**

The sponsor was aware of some of the benefits of laminar flow and had previously researched means of improving current Super Soaker® nozzles to increase distance. A paper by Zia Sobhani [10] discussed ways of improving Super Soaker® stream distance. Sobhani added flow straighteners, including honeycomb matrices of straws and screen mesh, into the exit nozzle. The straighteners were added to damp out turbulence and calm the flow before exiting. An approximate 5% increase in distance was achieved using this method. Sobhani suggested increasing the shaft/exit-hole ratio to improve performance. With this redesign, the flow comes nearly to rest in a calm pool of zero turbulence behind the nozzle and is then accelerated into a glassy stream through a small exit hole.

The described concept had been implemented in the past in the form of a fountain (Leapfrog Fountain™, Jumping Jet™, etc.). These fountains were developed by Mark W. Fuller and Allen Robinson of WET Labs/Design. The fountains involve a cylindrical water chamber with an internal screen structure or honeycomb mesh to remove the turbulence from the water. Water is pumped into the chamber at one end, and a continuous stream of water is accelerated out of a small hole on the opposite end. Directly in front of the exit nozzle is a cutting mechanism that blocks the laminar flow at regular intervals to create the illusion of a “water worm” or a jumping segment of water. This effect is shown in Figure 3-11. A portable version of



this concept was the basis for the Water Worm Shooter.

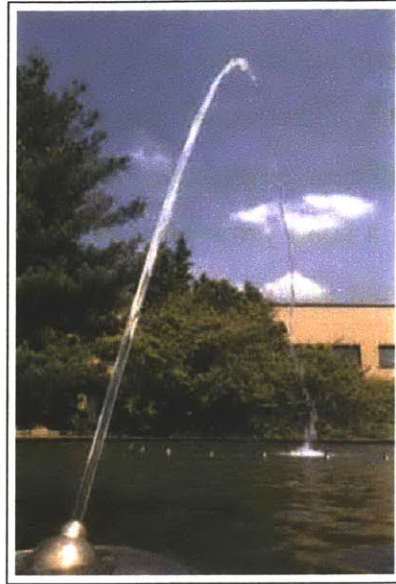

Figure 3-11: Photograph of a Fountain creating the Water Worm Effect

Before constructing a sketch model, a simple calculation was made to determine the target velocity desired inside the water chamber. Velocity was calculated using a Reynolds number of 2300 to identify the maximum bound for laminar flow, density and viscosity of water at 20 degrees Celsius, and an assumed pipe diameter of 4.5 *in* (taken from the current fountain design). It was determined that a velocity of approximately .7 *in/s* was needed to produce a fully developed laminar flow. This relatively slow flow was achieved through the use of mesh screening. Using conservation of volumetric flow rate, an exit stream velocity of 30 *ft/s* was calculated assuming an exit-hole diameter of .2 *in*.

The sketch model involved attaching a chamber to a preexisting Super Soaker<sup>®</sup> (CPS 2500). The chamber was composed of two PVC piping ends with 4.5 *in* ID. The back end piece was fitted with a screw off section to allow for interchanging of flow reducing materials. Different amounts of mesh screen layers and a honeycomb straw matrix (composed of .1 *in* thin walled straws) were tested inside the chamber. A .2 *in* hole was drilled into the center of the front end piece. The chamber is shown in Figure 3-12a. A plastic tube was attached with waterproof putty to the back end

of the chamber and connected to the nozzle of the Super Soaker<sup>®</sup>. The Water Worm Shooter sketch model is shown in Figure 3-12b.

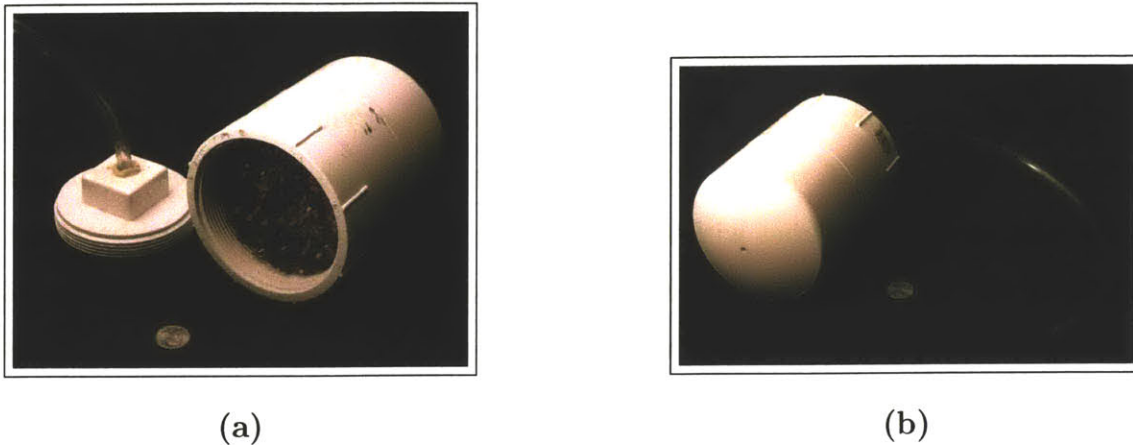

Figure 3-12: The Water Worm Shooter Sketch Model

A borderline laminar flow stream was created using the chamber, and the mesh screen produced a better stream than the straw matrix. The overall distance was not greater than current blasters, but a high quality prototype that eliminates all sources of internal turbulence could essentially produce better results. The sponsor produced a similar working prototype in parallel.

Several problems arise from the Water Worm Shooter. A cutting mechanism needed to be attached to the front of the blaster nozzle to redirect the stream. If water is not to be wasted while cutting the flow, a means of redirecting the cut sections needed to be developed. A large chamber is required at the end of the water gun. In addition to increasing the size of the blaster, this chamber requires an additional amount of water supply. The team looked into other means of creating a “chunk” of water.

### Water Ball Launcher

The Water Ball Launcher involved projecting a ball or “blob” of water rather than a segmented worm. The team decided to prototype this using a slingshot type mechanism. A tube filled with water would be accelerated over a distance and then quickly

decelerated. Calculations were performed to determine possible acceleration and distance achieved by a “blob” of water modeling the “blob” as a solid.

The sketch model consisted of an acceleration tube and water canister. The acceleration tube, shown in Figure 3-13a, was a 4 in ID PVC tube with a length of 4.5 ft. The water canister, shown in Figure 3-13b, was an acrylic tube closed on one end with 2.25 in ID and 2.5 in OD. The canister was fitted with two plastic bearings on either end. Four latex tubes with a length of 1.5 ft were attached to the bearing at the open end of the canister. The latex tubes acted as the spring mechanism and were attached to the perimeter of the expelling end of the acceleration tube. A rope was attached to the canister as a means to pull the canister through the acceleration tube and stretch the latex. A rubber o-ring stop was placed in the acceleration tube approximately 1.5 ft from the expelling end.

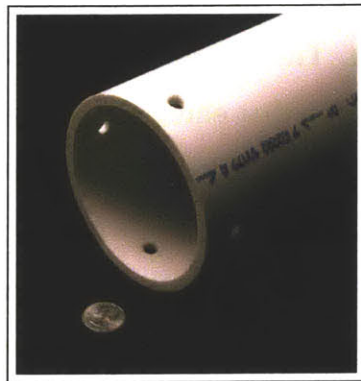

(a)

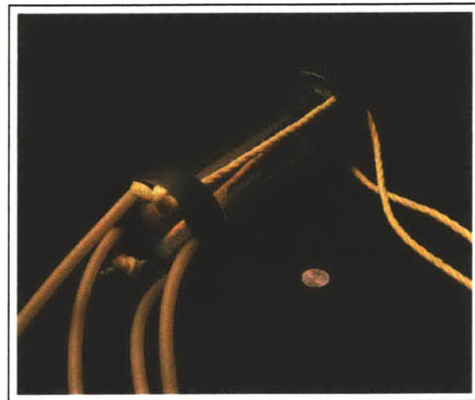

(b)

Figure 3-13: Components of the Water Ball Launcher Sketch Model

The sketch model was unsuccessful in launching a “chunk” of water. The hard stop gave rise to significant amounts of turbulence in the water and the result was a scattered splash out of the expelling end of the acceleration tube. The wall friction of the acrylic canister also added to the turbulence. A redesign could involve a softer stop and a low friction (perhaps waxed) inner canister surface. The laminar flow Water Worm Shooter was a better means of creating a “chunk” of water.

## **Spinning Sling**

The Spinning Sling was not prototyped due to time constraints. The concept involved a horizontal in-plane spinning hose that expelled a small volume of water at a timed interval. The water would be expelled when the hose reached a certain position. The resulting effect would be similar to water bullets in machine fire. This concept is a simple means of creating a sectioned water projectile.

The sponsor sought interest in the laminar flow mechanism (Water Worm Shooter) and possibly the Spinning Sling. However, at this point in the research, the sponsor had decided to keep the water products in-house for further development and focus the team solely on Nerf<sup>®</sup> or foam-related products.

### **3.3.5 Foam Grenade / Hopper Popper Activation**

The original concept of a Foam Grenade was a package that was thrown and expelled pieces of foam on impact. This concept presented inherent safety issues regarding launching foreign objects and high Kinetic Energy Density; it was ranked as a second tier concept by the sponsor. The team felt that this concept was worthy of a physical prototype. This section documents the prototyping and evolution of the Foam Grenade concept.

The team decided that the safest means of creating an exploding package was through the use of a bi-stable mechanism embedded in a rubber or foam skin. Foam pieces would be squeezed inside an inverted bi-stable rubber pouch. Upon impact, the pouch would invert, expelling the foam pieces. The first attempt at physically prototyping this concept involved cloth coated spring stock (slap bracelets). Two slap bracelets were inverted around a foam ball and the entire package was thrown into the air. The bracelets returned to their original shape and projected the ball a small distance. A better solution involved an injection-molded rubber bi-stable toy called a “hopper popper” or “dropper popper.” These toys will be referred to as “poppers” for the entirety of this thesis.

## Hopper Popper

The popper, shown in Figure 3-14a, is approximately half of a hollow rubber ball which stores energy when inverted, as shown in Figure 3-14b. An inverted popper, when placed or dropped onto a surface, converts the stored energy into kinetic energy and propels itself into the air. The poppers referenced in this paper are injection molded rubber with a diameter of 2.2 *in* and an average mass of 20.5 *g*.

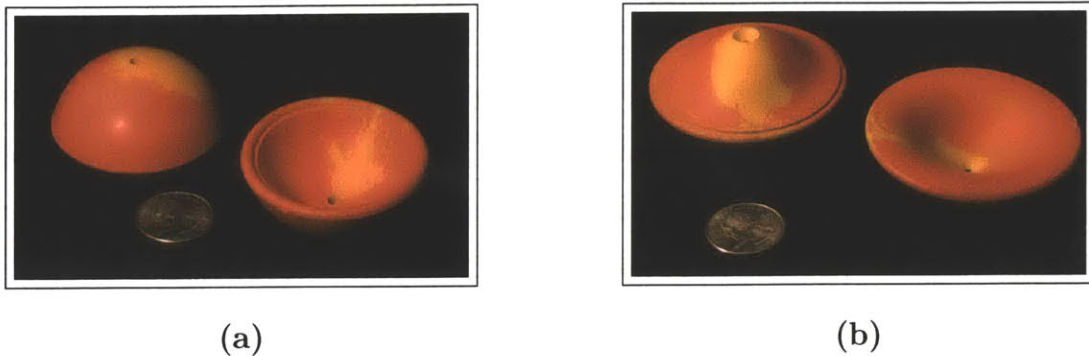

Figure 3-14: The Hopper Popper in the Natural and Inverted State

The team found that these poppers can be used to propel foam balls (mass of 4.34 *g*) a great distance. A ball resting inside an inverted popper, as shown in Figure 3-15, can be projected approximately 16 *ft* into the air vertically. This translates to a horizontal distance of approximately 32 *ft* if launched at a 45 degree angle. The team determined that the popper was suitable for much more than a grenade application. It can be applied to different blasters as a new means of projecting foam balls and possibly darts.

A device had to be designed to hold the popper and allow it to invert and return to its normal configuration. The team decided to machine this popper holder from 3 *in* delrin rod stock. The popper was modeled in SolidWorks™ in its inverted state in order to design the interior geometry of the holder.

Figure 3-16 shows the cross section of the inner structure of the popper holder. A lip was incorporated into the holder. This lip acted to retain the ball, thus keeping the popper from inverting until triggered by the user. Without the lip, an inverted popper restored immediately. In loading, the device is usually pressed down onto a



Figure 3-15: Foam Ball Resting in an Inverted Hopper Popper

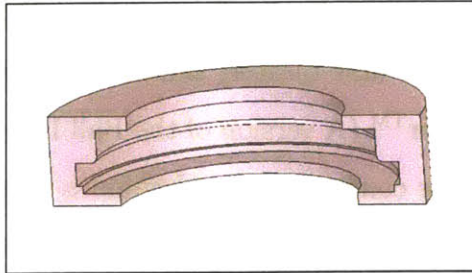

Figure 3-16: Cross Section of the Popper Holder

ball with a good amount of force. This inverts the popper and retains the ball until firing is desired. The final popper device is shown in Figure 3-17.

### Implementation

The popper device had several advantages over the current Hasbro® Ball Blasters™. The entire mechanism is two pieces and can fit inside the palm of your hand. The concept is simple, effective, and relatively inexpensive to manufacture. Finally, the concept can be applied to a variety of different toys. As expressed by Ulrich and Eppinger [11], although concept selection is usually a convergent process, occasionally a concept is improved, which temporarily enlarges the set of concepts under consideration. This occurred with the Foam Grenade, as the development of the popper device led to the generation of several additional concepts. The versatility of the popper device is shown in this section.

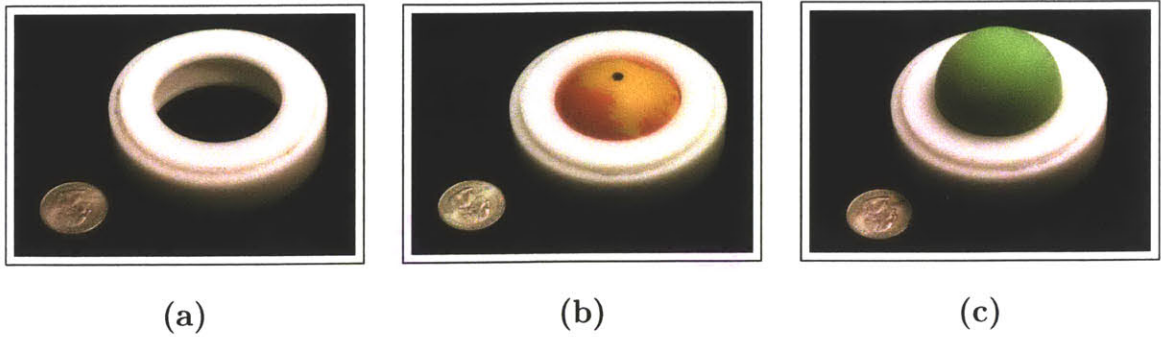

Figure 3-17: The Hopper Popper Holder

**Ball Blasters** The team first applied the popper device to handheld blasters as a means of comparison to current Hasbro® products. Three blasters were created using the popper device. The first blaster, shown in Figure 3-18, incorporated the body of a Nerf® Atom Blaster™ (A version of the Ball Blaster™). The Nerf® Atom Blaster™ fires foam balls by compressing air behind a retained ball. In this design, the popper device was attached to the front end of the blaster. A wooden dowel on a bearing was attached to the body interior to act as a trigger. When “pumping” the blaster, instead of increasing the pressure behind the ball, the trigger activates the popper device.



Figure 3-18: Hopper Popper Implemented into the Atom Blaster™

The next two blaster models incorporated the frames of Zero Toys® Products: the Zero Blaster™ and Zero Launcher™. The Zero Toys® products create smoke rings or toroidal vortices by hitting a diaphragm behind a chamber filled with smoke. Figure 3-19a, shows the popper device installed in the body of the Zero Blaster™. In this

sketch model, the trigger mechanism used to hit the diaphragm was modified to trigger the popper device. A similar sketch model was made using the Zero Launcher™, shown in Figure 3-19b. This sketch model was a more compact design and utilized a simpler trigger mechanism. The team noticed that the popper device was relatively hard and uncomfortable to load, especially when attached to a blaster. Another variety of prototype was created in an attempt to solve this problem.

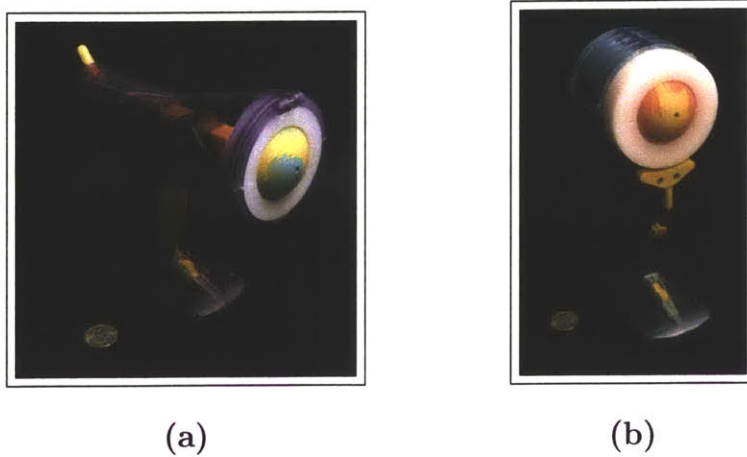

Figure 3-19: The Hopper Popper Implemented into the Zero Toys® Products

**Post-Pickup** The team decided that a blaster which picked up balls from the ground can ease the loading by allowing the user to invert the popper with their body weight. This design also allowed the user to refrain from bending over to pick up balls. Two sketch models were made to demonstrate the concept of a post-pickup.

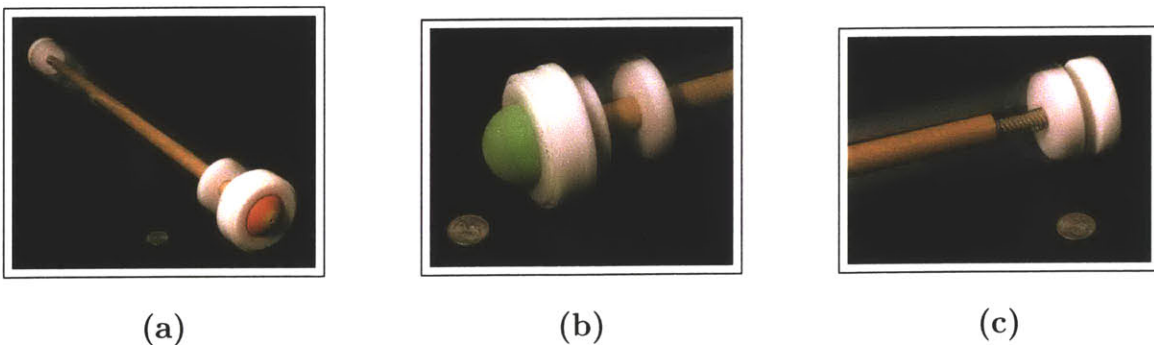

Figure 3-20: The Trigger Activated Post-Pickup Sketch Model



In the first post-pickup design, shown in Figure 3-20, the popper device was affixed to a piece of delrin press-fit into a 2 in acrylic tube. A spring loaded wooden dowel on a delrin bearing acted as a touch sensitive trigger mechanism. Foam balls were loaded and picked up off the floor in one motion and then fired with a gentle press of a button. The second post-pickup design, shown in Figure 3-21 was similar to a blow-dart gun. In this sketch model, the popper device was directly press-fit into a 3 in acrylic tube. Opposite the popper end, a delrin mouthpiece was machined to press-fit. The hole at the top of the popper was sealed with silicone to prevent the ball from ejecting prematurely. This design was unsuccessful as the popper device was not created to seal completely; the ball was blown out before the air pressure inside the tube could trigger the popper. A better means of retaining the ball was needed.

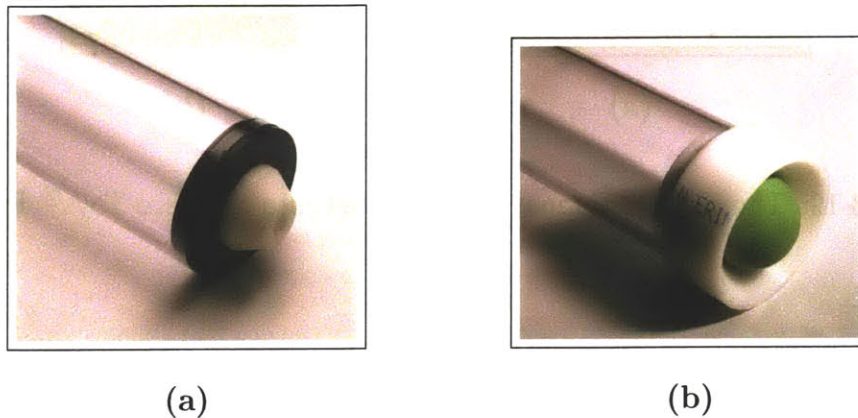

Figure 3-21: The Blow-Dart-Like Post-Pickup Sketch Model

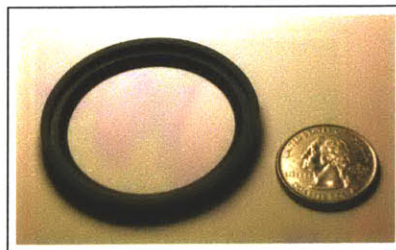

Figure 3-22: Retainer Ring Used in the Atom Blaster™

At first, the team incorporated the entire rubber retainer rings, show in Figure

3-22, used in the Hasbro® Ball Blaster™. These rings were unsuitable for the popper device as they were overly restricting. The team found that segments of the rubber retainer ring spaced evenly around the device opening worked well to restrain the ball. A new machined holder composed of three parts was developed to incorporate the retainer tabs. The tabs were held between a face plate and grooved plate. These plates were then bolted to a thinner version of the popper holder. This redesigned popper device incorporating rubber retainer tabs is shown in Figure 3-23.

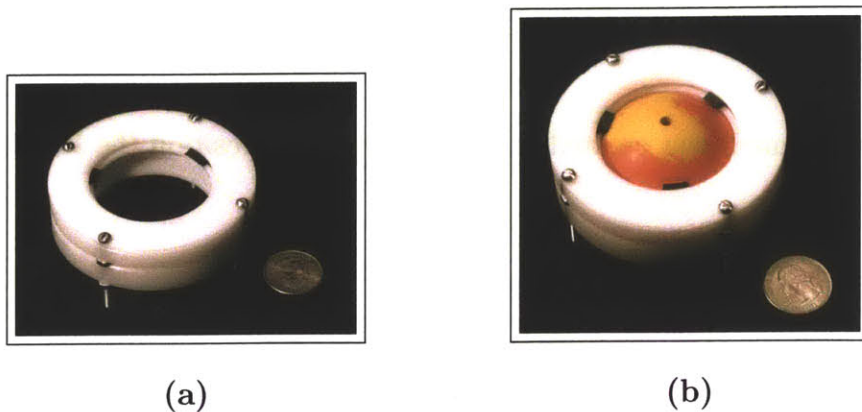

Figure 3-23: The Redesigned Holder Incorporating Rubber Tabs

**Hand Popper** The team implemented this improved popper device in a sketch model called the Hand Popper. The team determined that a trigger mechanism was not needed to activate the popper. The popper can be activated simply by touch. The popper device was also small enough to be handheld. These realizations led to the concept of the Hand Popper as shown in the concept sketches of Figure 3-24. The popper device itself served as the Ball Blaster™, thus simplifying the design. The team determined that the device should be comfortably strapped directly to the user's hand in such a way that allows the user to both load balls easily and trigger the popper with the palm of the hand.

The sketch model of the Hand Popper is shown in Figure 3-25. It was developed by simply attaching a Velcro backed strap to the enhanced popper device. The strap was connected with bolts joining the tab holder section and the popper holder section.

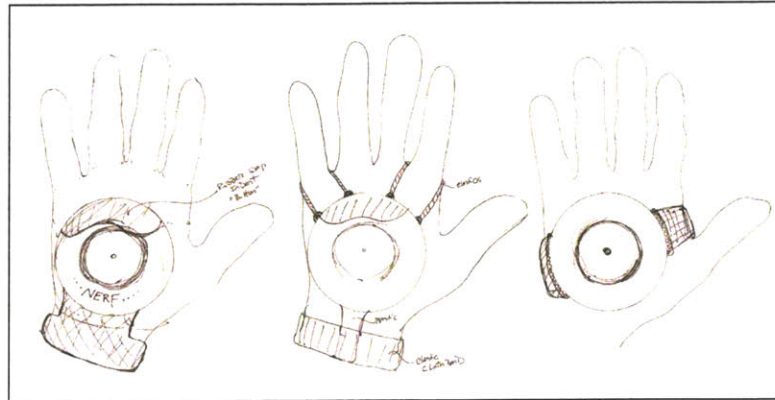

Figure 3-24: Concept Drawings of the Hand Popper

A hole for the thumb was created in the strap to help position the Hand Popper on the palm.

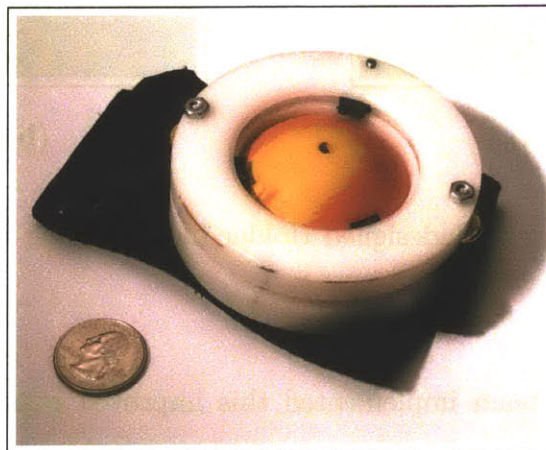

Figure 3-25: The Hand Popper Sketch Model

Occasionally the palm would trigger the popper prematurely or restrict the popper device from properly loading a ball. The Hand Popper, although somewhat uncomfortable and temperamental in loading and firing, proved to be a means of simply and discretely launching foam balls.

**Stomp Grenade** A sketch model was made to show how the popper device can be implemented as a Foam Grenade. The idea involved multiple popper devices facing outward from a central bladder. When all devices were loaded, the user would stomp

on an external bladder/pump that would expand the bladder inside the grenade thus activating all poppers simultaneously. This concept is shown in Figure 3-26.

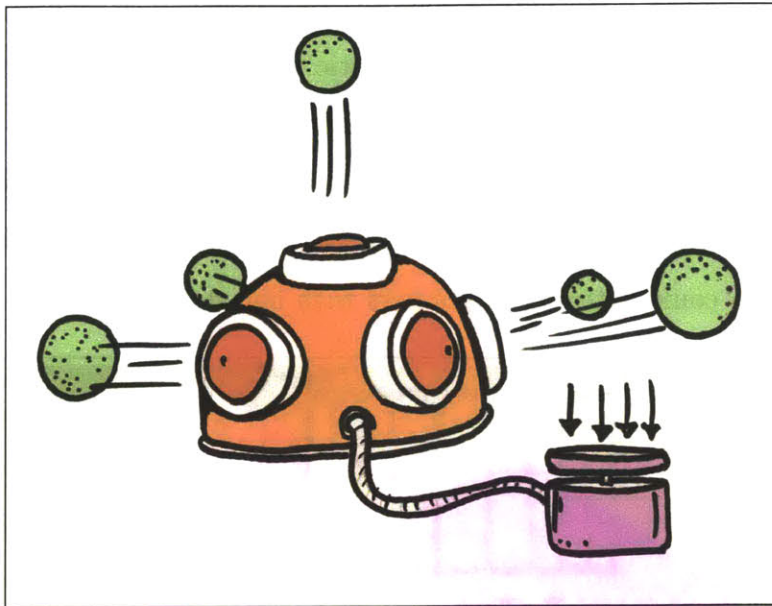

Figure 3-26: Concept Sketch of Stomp Grenade

Before constructing a sketch model, an improvement was made on the actual popper device. As shown in Figure 3-27, the popper-holding section was merged with the tab-holder section. A taper on the upper edge was added for aesthetics. A face plate was still needed to hold the rubber tabs in place. This face plate was bolted to the main section of the device.

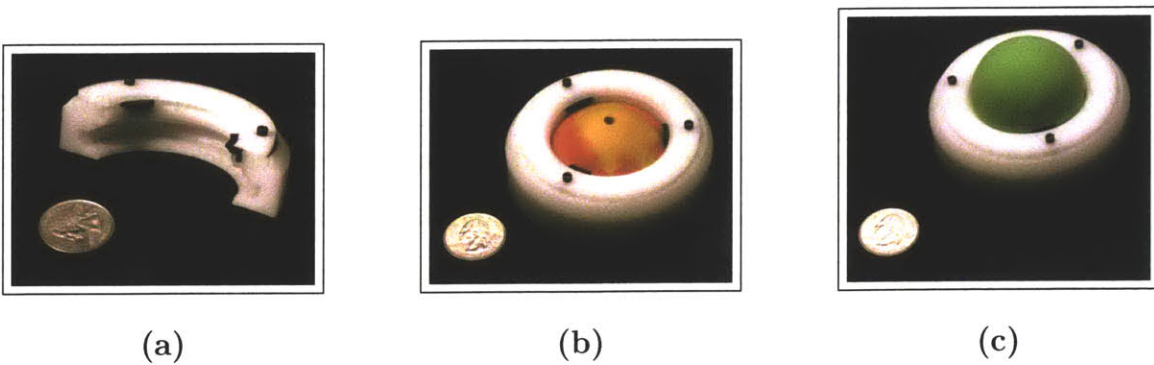

Figure 3-27: Refined Popper Holder

In prototyping the Stomp Grenade, it was determined that a balloon can serve

as the central triggering bladder. A hollow cubic frame was machined from high density polyurethane foam. Four popper devices were affixed to four faces of the cube, leaving one solid plate with a hole for the balloon and one face to act as a support. The balloon was attached to a plastic tube with a hose clamp. The other end of the tube was attached to a plastic bladder with a hose clamp. This plastic bladder served as the user stomp pad. The Stomp Grenade sketch model can be seen in Figure 3-28. To function properly, the bladder system needed an initial volume of air so the balloon could activate all poppers with one stomp.



Figure 3-28: The Stomp Grenade Sketch Model

The Stomp Grenade was capable of launching four foam balls simultaneously. Air leakage was occasionally a problem, as well as time-staggered launching.

The sponsor was impressed with the simplicity, effectiveness, and versatility of the concept of Hopper Popper Activation and encouraged further development. The sponsor emphasized improving the ergonomics and loading of the Hand Popper. The sponsor requested further research into the Foam Grenade applications.

### 3.3.6 LED Darts

The concept of the LED Dart involved incorporating a light source into a foam dart to enhance the visual experience during play and especially during nighttime play.

The resulting effect produced by the LED Dart in low light conditions would be comparable to tracer shots or “laser bullets” as seen in science fiction media. The concept, shown in Figure 3-29 incorporated a light-source, a power source, and a switch all embedded inside a single dart. Darts would charge while inside the blaster and then upon firing, the darts would illuminate during flight. This section documents the development of the LED Dart sketch model.

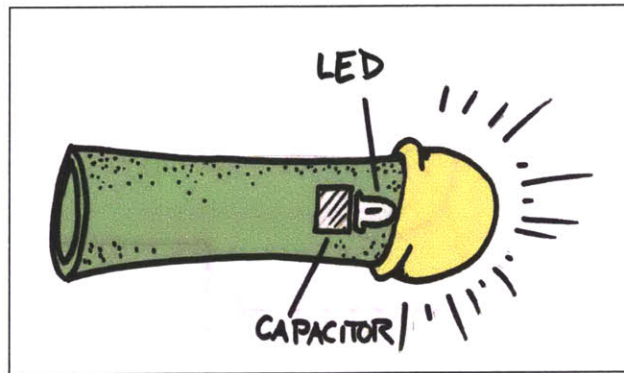

Figure 3-29: Concept Sketch of LED Dart

All internal dart components must be as light as possible so as not to decrease performance. Therefore, the team chose a capacitor, as opposed to batteries, as the means of supplying power to an LED. Capacitor technology has rapidly advanced as Farad capacitors with low internal resistance are now relatively inexpensive. Capacitors have a longer life expectancy than rechargeable batteries. In addition, batteries contain toxic chemicals and are unsuitable for disposable items such as darts. The team determined the feasibility of a capacitor-powered LED Dart through analytical models and circuit design.

### Circuit Design

The team wanted the LED in the dart to be strongly illuminated for the full duration of flight. A first order energy calculation using Equation (3.2) was performed to determine if a capacitor is capable of providing the required energy to illuminate an LED.

$$energy = \frac{VI}{t} = \frac{1}{2}CV^2 \quad (3.2)$$

Assuming a high frequency LED is illuminated for 5 seconds, consumes 3.7 V, draws 25 mA of current, and uses all of the energy of the capacitor, a capacitance of .0027 F would be required. This value appears large, but is reasonable with current technology.

A general circuit layout was then developed shown in 3-30.

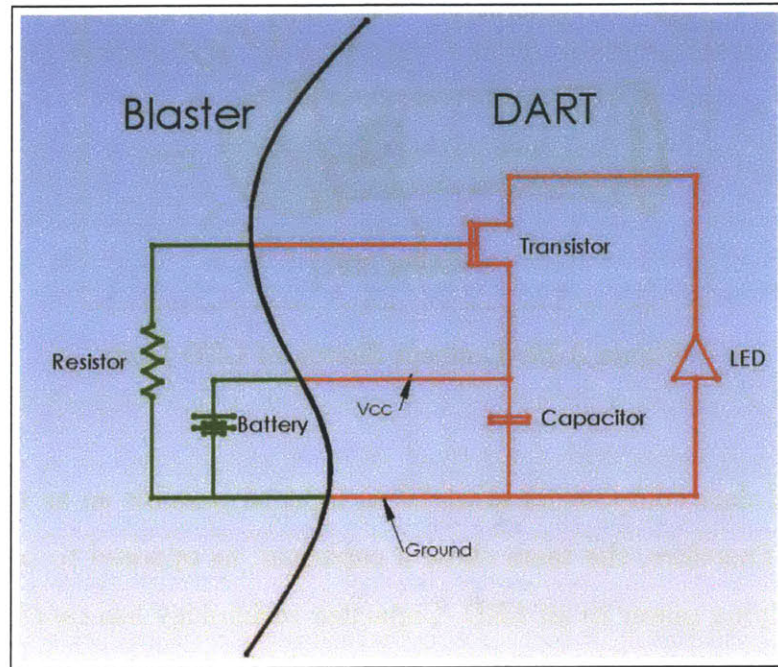

Figure 3-30: The General Circuit for the LED Dart

The design of the circuit began with the capacitor being the most critical component. The team approached the selection of the capacitor with the following analytical method.

$$V = V_{cap}e^{-\frac{t}{RC}} \quad (3.3)$$

Equation (3.3) describes a capacitor discharging; Where  $V$  is the voltage across the LED,  $V_{cap}$  is the voltage of the capacitor,  $t$  is time,  $R$  is the resistance and  $C$  is the capacitance.

To illuminate a very bright blue or green LED, at least 3.0  $V$  are required throughout the duration of flight (about 2 seconds). Electric double-layer capacitors (high Farad) are available in either 2.5  $V$  or 5.5  $V$  and the latter was chosen for this analysis and sketch model. The electric double-layer capacitors have an internal resistance of 100  $\Omega$ . These values were placed into Equation (3.3) to determine that a capacitance of approximately .025  $F$  was required. The team chose a .022 $F$  capacitor which provided more than enough energy for red, yellow and orange LEDs and sufficient energy for blue and green LEDs. The team tested this capacitor on the variety of LED colors and it proved to be successful. These capacitors kept the low frequency LEDs bright for 15 seconds and continued to be dim for 10 minutes. In addition, they kept the high frequency LEDs bright for over 2 seconds.

A circuit had to be designed to allow the capacitor to charge while the dart was in the blaster and discharge upon the dart exiting the blaster. The LED must remain off while the dart was in the blaster. These requirements were made possible using a transistor as a switch. Three electrical contacts were needed; one ground, one positive (or high potential) and one contact to activate the switch.

It was determined that the transistor must be naturally “on” or in depletion mode until activated. The team tested several N-channel depletion mode FETs in the circuit of Figure 3-30. Most of the transistors had a large voltage drop which prevented the LED from illuminating. Other transistors had a leakage voltage greater than 3  $V$  which resulted in the LEDs illuminating while the transistor was in the off configuration. The MPF 102 transistor leakage voltage varied around 3  $V$  which was the breakdown voltage of the blue, green, and white LEDs. This transistor did not work for the lower frequency LEDs (red, orange, and yellow). An LP395z transistor with a much lower leakage voltage worked for all color LEDs; however, it was several times more expensive. This low leakage voltage transistor was implemented in only the lower frequency LED Dart sketch model.

Having chosen the capacitor and transistor elements, the team optimized the circuit. As shown in the general circuit illustration (Figure 3-30), the capacitor was connected in parallel with the battery from ground to the emitter. The LED was



connected from the collector to ground. The team found that a bleed resistor was needed to bring the base up to  $V_{cc}$  in order to turn on the transistor when disconnected from ground. To maximize circuit efficiency, the highest value resistor (10K) capable of keeping the transistor turned off was used to connect the ground to base. No external resistor was needed in series with the LED as the electric double-layer capacitors have an internal resistance of about  $100 \Omega$ . The optimized circuit to be used in the sketch model is shown in Figure 3-31.

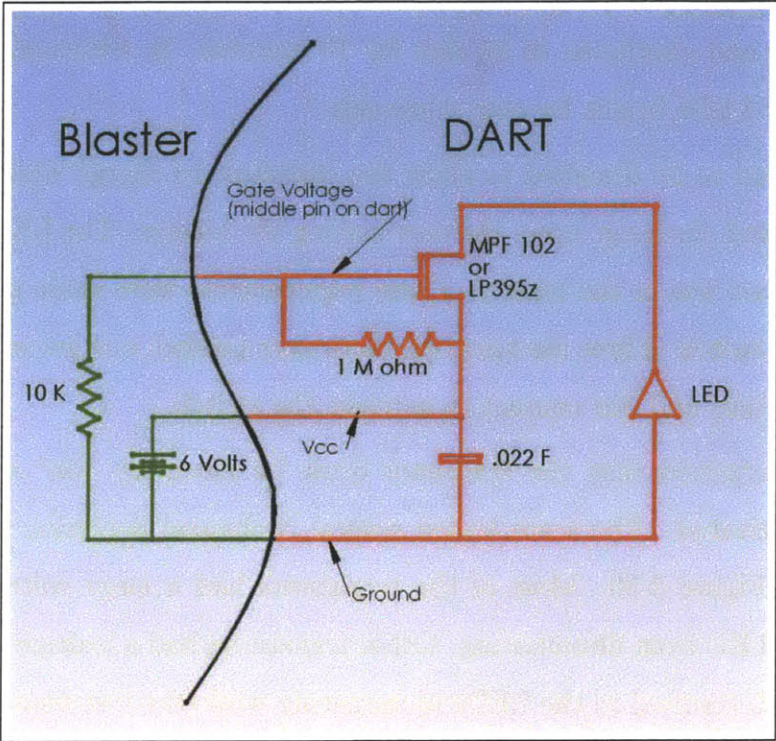

Figure 3-31: The Optimized Circuit for the LED Dart Sketch Model

The optimized circuit shows the three connections needed between the dart and blaster. Inside the blaster, a battery and resistor were required. The battery served to charge the capacitor, and the resistor served to ground the transistor to switch it off. With a working circuit tested on a breadboard, the team proceeded to implement the circuit into a dart.

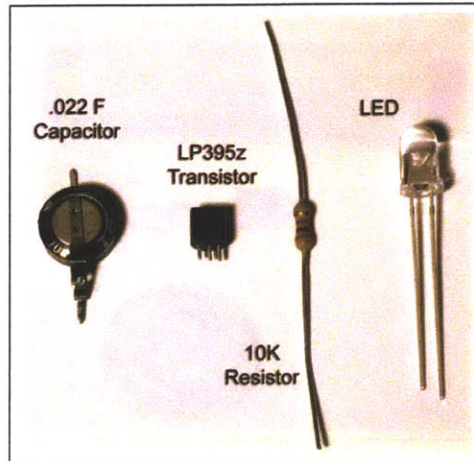

Figure 3-32: The Electronic Components of the LED Dart Sketch Model

## Implementation

The team first determined if the added weight of the circuit components, shown in Figure 3-32, would effect the flight performance of the dart. After several tests of firing component-filled darts from a Nerf® PowerClip™, the team determined that the orientation of the components, rather than the weight, was the dominant factor in flight performance. It was found that the weight must be symmetric about the dart axis and near the front end of the dart. Without axial symmetry, the dart fishtailed and decelerated immediately after firing. With a weighted front, the dart flew effectively as the drag remained behind the mass. A properly oriented component-filled dart reached comparable distances to unaltered darts. The layout of components for the LED Dart sketch model is shown in Figure 3-33.

The LED was oriented facing away from the direction of travel, so the user can experience the full effect. In this position, the LED also illuminated the foam body of the dart. All other components were placed as close to the front end of the dart as possible in a symmetric manner. The heaviest component, the capacitor, was placed closest to the dart tip. The transistor was centered directly behind the capacitor. The resistor was centered behind the transistor. All components were soldered together as described by the optimized circuit of Figure 3-31. The three leads extended out the front end of the dart and wrapped around the outside of the dart body as shown

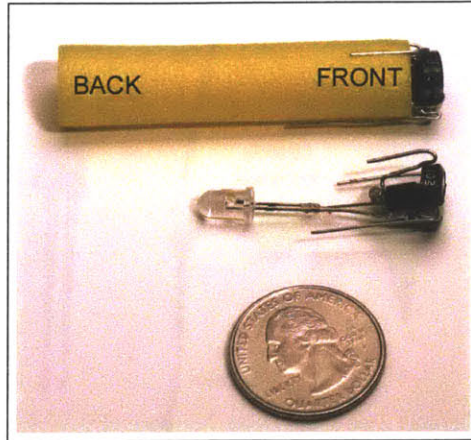

Figure 3-33: The Assembled LED Dart Sketch Model

in Figure 3-33. The total average weight of the sketch model was 2.09 *g* without a resilient tip and 2.71 *g* with a resilient tip (not shown in the figure). Current unaltered foam darts range from .8 *g* to 1.8 *g*.



Figure 3-34: The Nerf® PowerClip™

The team determined that the Nerf® PowerClip™ was the optimal means of firing the LED Darts. The PowerClip™, with its ten-dart-magazine rapid fire, enhanced the overall effect. In addition, only one component, the magazine, needed to be modified to support the LED Darts. The PowerClip™, shown in Figure 3-34, utilizes a CPS bladder to advance the magazine and propel the ten darts in sequence.

The first step in modifying the PowerClip™ for the LED Dart application was removing the internal safety posts in the magazine barrels. The posts served to

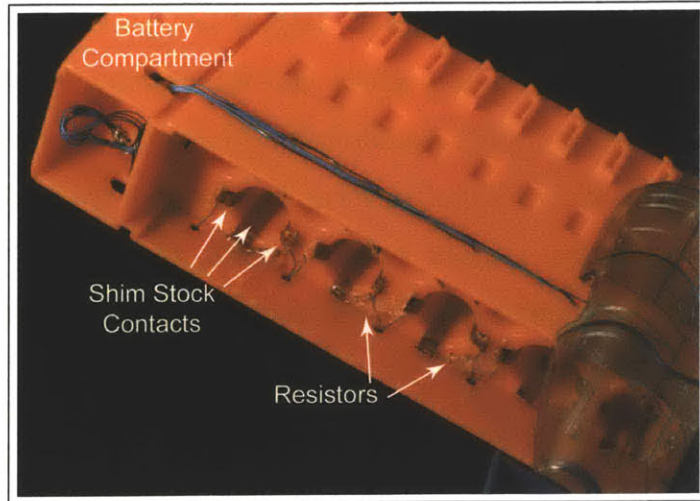

Figure 3-35: The Modified Clip with Shim Stock Contacts

prevent the user from launching foreign objects. Later iterations introduce the safety posts back into the blaster. The team then created the blaster-side contacts from strips of .001 *in* copper shim stock. These contacts were secured into place with epoxy as shown in Figure 3-35. The base contact was connected to ground through a 10K  $\Omega$  resistor. All power contacts were painstakingly soldered to 30 gage wire segments. These wires traversed the side of the magazine and to a 6 V Alkaline battery placed in the top compartment of the magazine. A push-button was placed in series to allow the user to charge the capacitors before use.

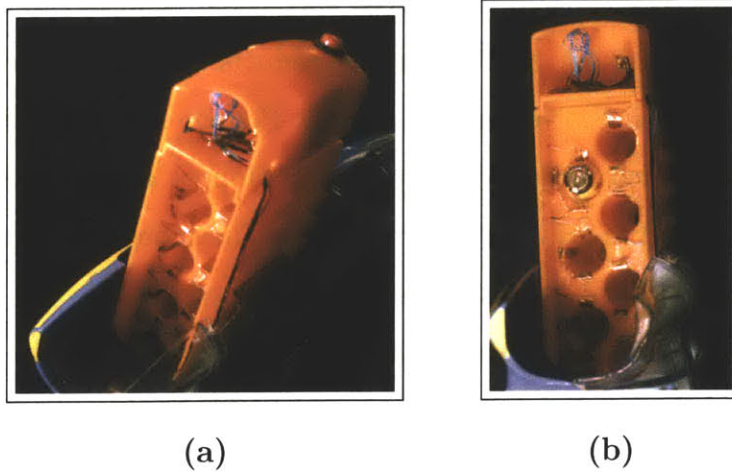

Figure 3-36: The LED Dart Sketch Model

The sketch model, shown in Figure 3-36, worked as expected; however, there were several knowingly unaddressed design issues. The three contact orientation made the darts directionally dependant which is undesirable for loading. In addition, there were several safety concerns with the design, including exposed sharp electrical contacts and possible Kinetic Energy Density issues. Overall, the sponsor was very pleased with the concept and its implementation and requested a second iteration.

### **3.4 Summary**

The original set of over 100 concepts was reduced to thirty potential concepts by intuition and multivoting. These thirty concepts were presented to the sponsor and twelve concepts were selected and placed into a three tier hierarchy. Sketch Models were made for selected high tier concepts: String Shooter, Rocket Darts, Mist Blaster, Water Blobs, Foam Grenade, and LED Darts.

The sponsor felt the String Shooter, when applied to darts, fits within the line of Nerf®. The String Shooter, however, would require a design that prevented projecting foreign objects. The Rocket Dart sketch model proved that an increase in distance can be achieved with a bladder-filled dart; however, the sponsor did not request immediate redesign. The Mist Blaster sketch model did not meet expectations and its application for snow production is highly dependant on ambient conditions. The Water Blob sketch models were somewhat successful; however, the sponsor urged the team to focus solely on Nerf® related products in further development. The Foam Grenade concept evolved into a Hopper Popper Activated line of concepts. The sponsor emphasized further development in Hopper Popper Activation applied to Foam Grenades and the Hand Popper concept. The sponsor was very pleased with the LED Dart concept and suggested further development.

With the sponsor feedback, the team chose to progress with the detailed design of the concepts of Hopper Popper Activation and LED Darts.

# Chapter 4

## Hopper Popper Activation

This section documents the detailed design and refining of the hopper popper activation concept. The detailed design stage covers the enhancement of the sponsor selected sketch models including the Foam Grenade and the Hand Popper. The refinement stage focuses solely on the Hand Popper; detailing the physics of the hopper popper, final apparatus design, manufacturing, and a comparison to the state of the art.

### 4.1 Detailed Design

The Detailed Design stage involved improving the geometry and materials to produce better functioning and aesthetically pleasing high-level prototypes. In this stage, the popper device was recreated in SolidWorks<sup>TM</sup> to be rapid prototyped. By rapid prototyping the popper device, the team was able to maintain consistency, increase accuracy, eliminate the machining time, and allow for space-saving external contours.

Three different internal geometries were prototyped with Selective Laser Sintering (SLS) technology to determine the optimal interior design for performance and loading. The three different geometries are shown in Figure 4-1. These prototyped devices are made in two parts, the body which houses the inserted popper and the o-ring which seals the rubber gasket segments inside. The team chose the internal configuration which involved the tightest internal geometry that allowed for sufficient

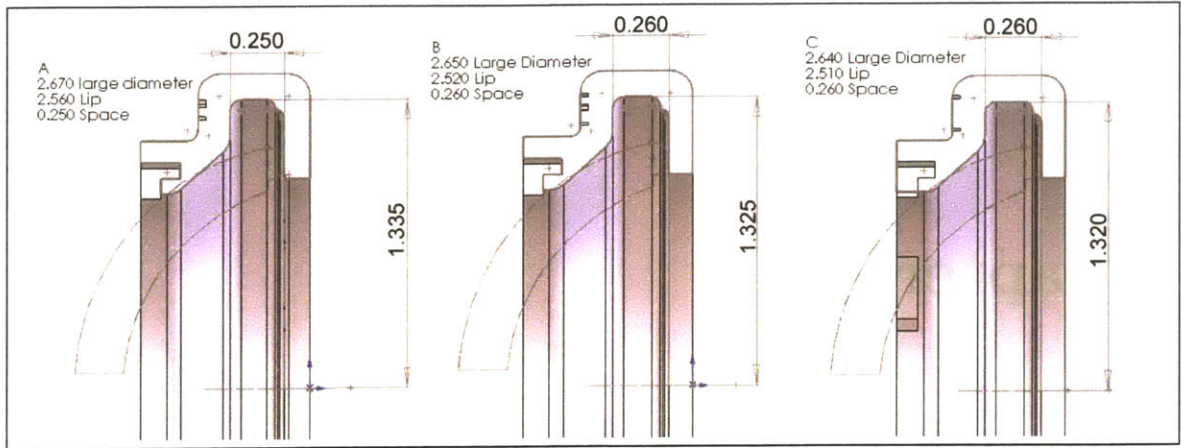

Figure 4-1: Alternative Inner Geometries of the Popper Holder

space to invert freely. A tight fitting internal geometry restrained the popper from shifting during loading. This popper device design, shown in Figure 4-2, was implemented in the prototypes discussed in this section. The sponsor was most interested in advancing the Foam Grenade concept and the Hand Popper Concept. This section discusses the evolution of these two Hopper Popper Activated concepts.



Figure 4-2: SLS Prototyped Popper Holder

#### 4.1.1 Foam Grenade

The Foam Grenade branched into three separate concepts including a stationary Stomp Grenade (an advancement of the sketch model prototype), a Remote Control Car Grenade, and a “Tossable” Grenade. The first two concepts were physically prototyped at a higher level of detail, and the latter remained at a concept level.

## Stomp Grenade

The team first redesigned the current Stomp Grenade concept. The sketch-model prototype had several opportunities for improvement. The team decided that a second generation prototype should launch more foam balls, implement the redesigned internal structure, and have an enhanced visual appeal. The team changed the design from the hollow cube shape, being the easiest geometry to construct by hand, to a hollow sphere which was easily created with Stereolithography (SLA) technology. The sphere shape allowed for many foam balls (nine) to be launched simultaneously. This was an improvement over the sketch model prototype capable of launching only four foam balls. The sphere shape was also aesthetically pleasing and more suitable for the round internal bladder.

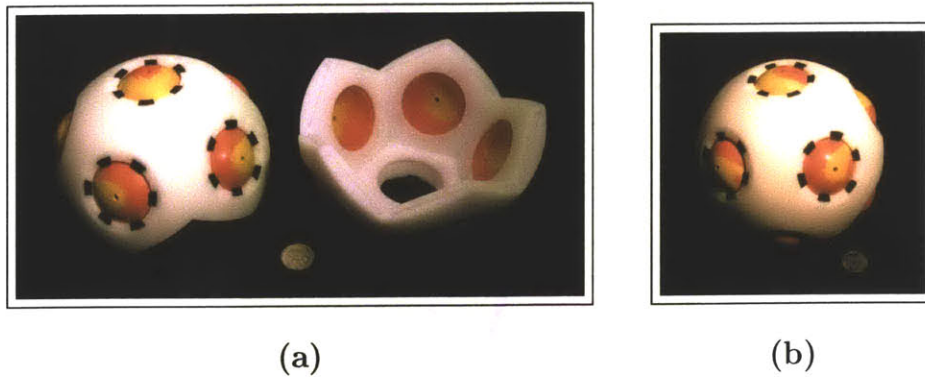

Figure 4-3: SLA Prototyped Stomp Grenade Body



Figure 4-4: Press-Fit Delrin Support



In physically prototyping the spherical Stomp Grenade, the team first developed a CAD model in SolidWorks™. The design began with the improved CAD model of the popper device. The team altered the popper device shown in Figure 4-2 to a form a pentagon. This shape was chosen to allow the popper device segments to piece together evenly creating a hollow dodecagon (12-sided) structure. The exterior was rounded thus joining all pentagons and creating a spherical exterior surface. The sphere was modeled as two hemispheres, shown in Figure 4-3a. This was done to allow for easier insertion of the poppers, conservation of space in the SLA machine, and possible addition of internal structure or post processing. Male and female mating tabs were added to the hemispheres to allow for easy assembly. The assembled sphere with poppers and rubber gasket tabs is shown in Figure 4-3b.

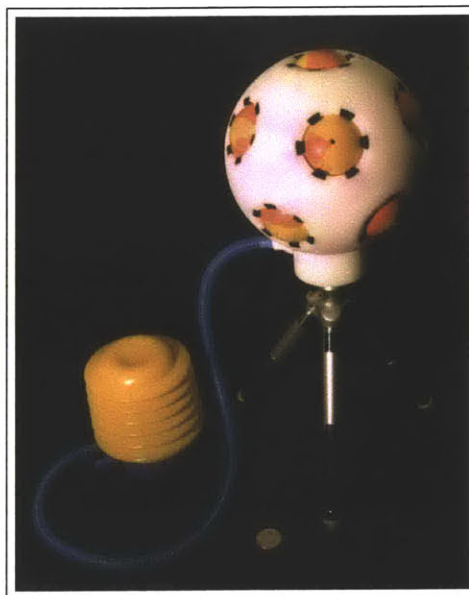

Figure 4-5: The Assembled Stomp Grenade

The team decided to mount the sphere onto an aluminum tripod. A delrin fitting was machined to press-fit into the sphere and thread onto a tripod stand. A channel was machined into the delrin fitting to direct air from a foot pump to a balloon inside the sphere. Fittings were machined into the delrin to allow for balloon attachment to the top and the press-fit of a foot pump tube on the side. This delrin fitting is shown in Figure 4-4. A foot pump with two one-way valves was attached to the delrin. The

assembled Stomp Grenade is shown in Figure 4-5.

This higher level prototype was successful as all nine balls launched at approximately the same time. A delayed effect might also be desirable. There were several design issues which can be overcome with proper manufacturing. The weight of the SLA prototype was much heavier than expected, but excess material can be eliminated. Occasionally, the two hemispheres separated on bladder expansion; however, in the refined toy, the sphere would be made in one piece. The greatest issue of concern involved the amount of force required to load the foam balls into the popper devices, and the ability to retain the balls until the bladder activates the poppers. The loading force and means of retention are both addressed in later sections as key issues of concern.

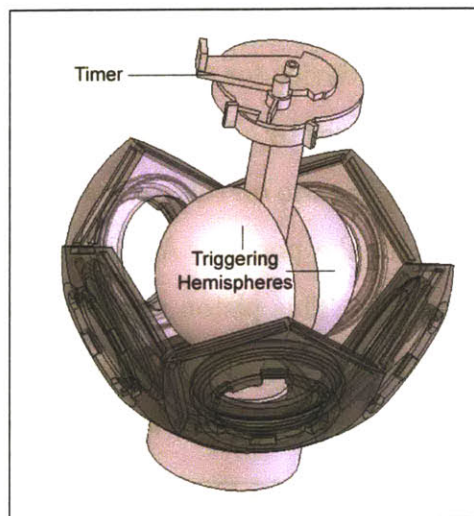

Figure 4-6: Model of a Grenade with Timer Mechanism

An additional suggested concept involved replacing the bladder and stopping activation with a timed spring-loaded internal mechanism. The Timer Grenade, although more complicated, detached the user from the grenade and created more “realistic” play. This concept was not prototyped, but a CAD model of this concept implementing a spring loaded timer is shown in Figure 4-6 (top hemisphere not shown). In this concept, the user sets a spring loaded timer, which turns an internal plate. When the timer reaches a certain location, the plate spins quickly separating two triggering

hemispheres thus activating all popper devices simultaneously.

## RC Grenade

The desire to separate the user from the grenade led to the implementation of a radio control activation. The team decided to create an inconspicuous grenade which launched only one foam ball. The concept involved attaching a popper device to a miniature radio controlled car and incorporating a means of remotely triggering the popper.

The team began with the smallest radio controlled (RC) car capable of supporting the weight of the popper device. The RC car was required to have at least three-channels to allow for the additional RC popping mechanism. The team procured a small RC car capable of normal steering with an additional RC motor feature. The team then redesigned the popper device for use on this RC car.

The team first modified the RC car by adding an additional external gear driven by the third function motor. The gear ratio on this external drive was reduced to provide higher torque needed to activate the popper. A friction drive piston was developed and coupled to the gear assembly. This piston extends to activate the popper. The team decided to use a friction drive to allow the system to be back-driven when inverting the popper. The drive assembly is shown in Figure 4-7.

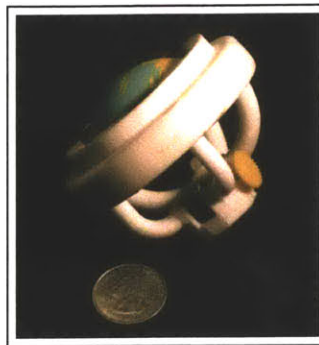

Figure 4-7: Customized Drive Assembly in SLS Housing for the RC Grenade

The team modeled a housing which incorporated both the popper device and the friction drive. The housing was designed to press-fit into the RC car chassis. The team

rewired the electronics to allow room for the housing attachment. The assembled RC Grenade is shown in Figure 4-8.

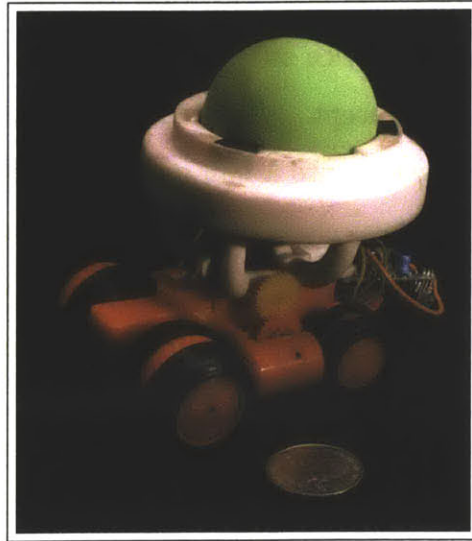

Figure 4-8: The Assembled RC Grenade

The RC Grenade performed as expected; however, the sponsor felt that an RC Grenade would not fit well within the line of Nerf® products.

### **“Tossable” Grenade**

The idea of the “Tossable” Grenade was a secondary use of the Stomp Grenade sphere. The concept involved placing a rubber ball inside the sphere, and as the sphere was tossed around, the ball inside triggered random poppers. This concept was not prototyped as the SLA sphere was much too heavy (and expensive) to be tossed around. The idea, however, is feasible and makes for an exciting toy.

A physical prototype would require a much lighter popper sphere and a layer of foam padding to allow for safe play. A possible design alternative could involve the timer concept presented in the Stomp Grenade section. Replacing the ball with an internal time-activated mechanism would allow for a simultaneous release of all the foam balls. This design lends itself to a Hot Potato-like children’s game.

### 4.1.2 Hand-Popper

The Hand Popper concept went through two detailed design iterations. Both iterations were rapid prototyped (the first with SLS and the second with SLA) using the redesigned internal popper device structure. There were several issues that were addressed in developing this concept. The Hand Popper needed to be much easier to load when pushing downwards onto a ball on a flat surface. The firing had to be reliable; the hand cannot prematurely activate the popper and the ball must be well retained. The Hand Popper was also in need of tactile and visual enhancement. This section documents the progression of the Hand Popper concept through two higher level prototype iterations.

#### Hand Popper (1st Iteration)

The greatest initial concern of the Hand Popper was its inability to fire reliably. In designing a new Hand Popper, the team decided to change from palm-triggering to a push-button trigger. This allowed for covering the backside of the Hand Popper, thus eliminating the possibility of premature launching by the palm. The team designed the trigger to push the side of the inverted hopper popper as shown in Figure 4-9. The trigger slides along a groove, created in an extrusion of the popper device body, and relies on a compression spring to return to its original position after firing.

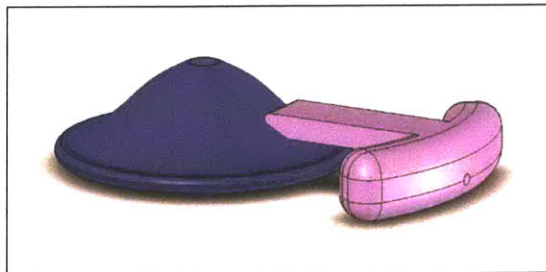

Figure 4-9: Trigger Pushing the Side of an Inverted Popper

An extra set of rubber gasket retainer segments was used to secure the foam ball from unintended firing. Grooves were modeled into the body to allow for easy attachment of a strap. The trigger top was rounded to match the contour of the

popper device body and a hard stop for the trigger was modeled as two aesthetically pleasing ribs.

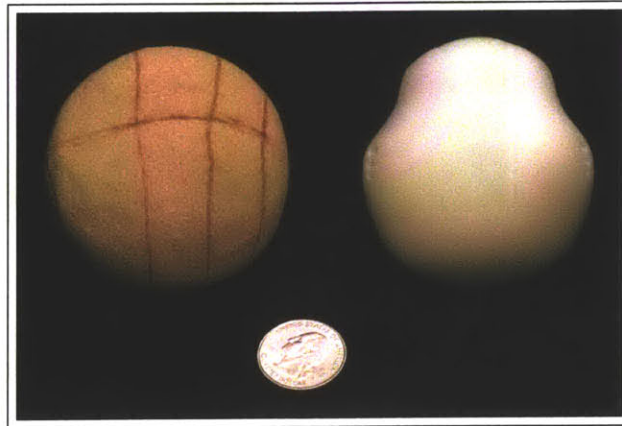

Figure 4-10: Foam and SLA Versions of the Hand Popper Backing Plate

The backing plate for the Hand Popper was SLA rapid prototyped as a separate part to allow for internal modifications, easy loading of the hopper popper into the device, and post processing. The backing plate was designed to fit the contour of the hand to allow for a comfortable grip on the toy. High density polyurethane foam was first used to sculpt a comfortable backing plate. This foam model was then reproduced in SolidWorks™ by following contour lines sketched onto the foam. The foam and SLA versions of the backing plates are shown in Figure 4-10. The inside of the backing plate was created by determining the room required by the inverted hopper popper. A guide ring was modeled into the backing plate to allow for easy assembly onto the Hand Popper. Vent holes were added to prevent a vacuum from forming behind the popper. The team found that the strap was uncomfortable and unnecessary. The assembled Hand Popper (1st Iteration) is shown in Figure 4-11.

This first iteration proved to be somewhat successful. The loading issue was improved, but still not sufficiently so, with the addition of the backing plate, as the entire hand could freely apply a loading force. The backing plate eliminated the possibility of premature firing by the palm. The force required to load was still relatively high for a children's toy and was addressed in further iterations. The backing plate, push button trigger, and additional gaskets improved the firing reliability; however,

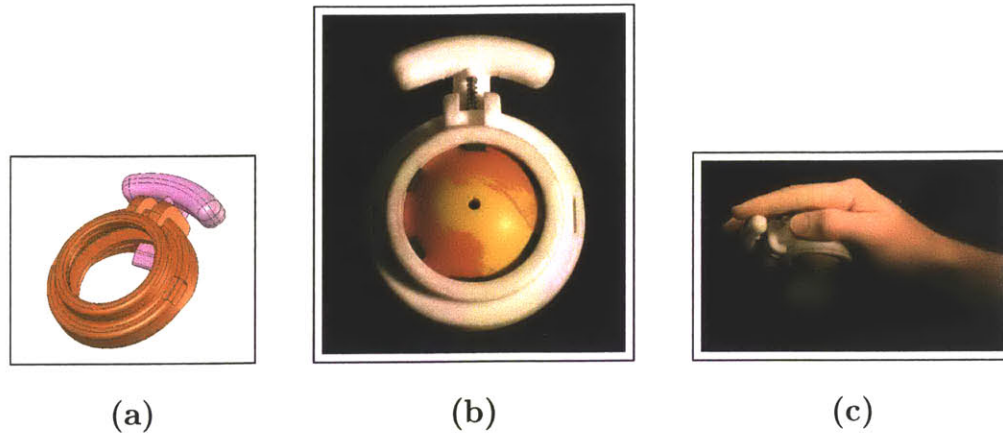

Figure 4-11: 1st Iteration of the Hand Popper

several issues remained. The trigger had a delayed response fire, and occasionally, the gaskets were not able to retain the ball. In addition, the trigger created a possible pinch point and needed redesign. The overall feel and appearance of the Hand Popper was increased, but there was need for further improvements.

### **Hand Popper (2nd Iteration)**

In the second iteration, the team addressed delayed trigger response, the trigger pinch point, the loading issues, and the tactile and visual elements. It was determined that the delay in trigger response was a result of the trigger force being applied at the side of the inverted popper. This resulted in the popper being pushed downward first before triggering the activation. The team decided to overcome this by adding a raised bump into the back plate opposing the trigger contact location. The bump, shown in Figure 4-12, restricted the popper from moving downward and resulted in immediate activation.

The team reduced the size of the trigger top and enclosed it in a sleeve. This sleeve eliminated the possible pinch point and added to the overall aesthetic by unifying the Hand Popper. The sleeve converted the trigger into a small button-like feature.

The team eliminated all strap elements and incorporated small dimples along the outer surface of the Hand Popper body. The dimples served as a grip for the user and enhanced the feel of the product. The dimples also added a visual appeal.

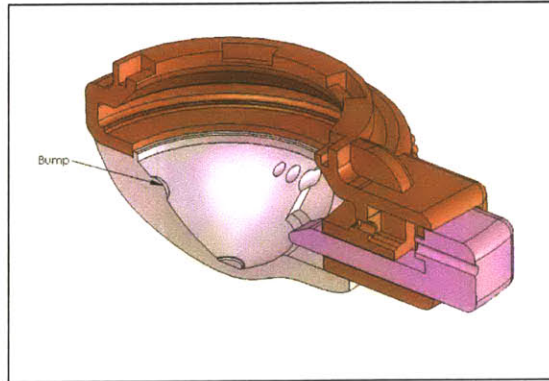

Figure 4-12: Bump Located in the Backing Plate

A loading channel was developed and attached to the front of the Hand Popper. This channel serves as a means of directing the ball to the center of the popper. The team found that loading was mollified when the ball was properly aligned. Two different channels were produced: a cylinder and flared cylinder. Both channels were approximately .5 *in* off the edge of the Hand Popper. This distance allowed the ball to be completely loaded into the Hand Popper before the channel makes contact with the loading surface. The flared channel directed the ball to the center; however, the cylindrical channel aligned the ball to the proper location. The cylindrical channel keeps the popper safely recessed into the toy.



Figure 4-13: Adjustable Ball-End Set Screw

With the cylindrical channel, the team addressed a solution for the unreliable ball retention as the rubber gaskets were occasionally unable to retain a ball. The team implemented ball-ended set screws, shown in Figure 4-13, which can be finely adjusted for appropriate retention. The set screws were able to control the direction of fire and thus align the system. Future references to the second iteration Hand



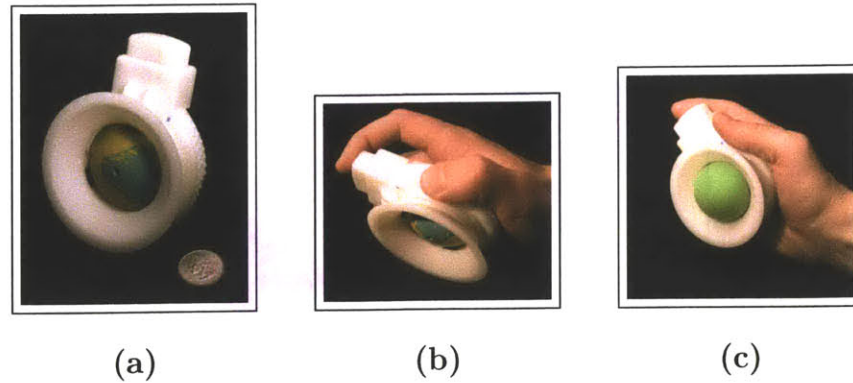

Figure 4-14: 2nd Iteration of the Hand Popper with Flared Channel

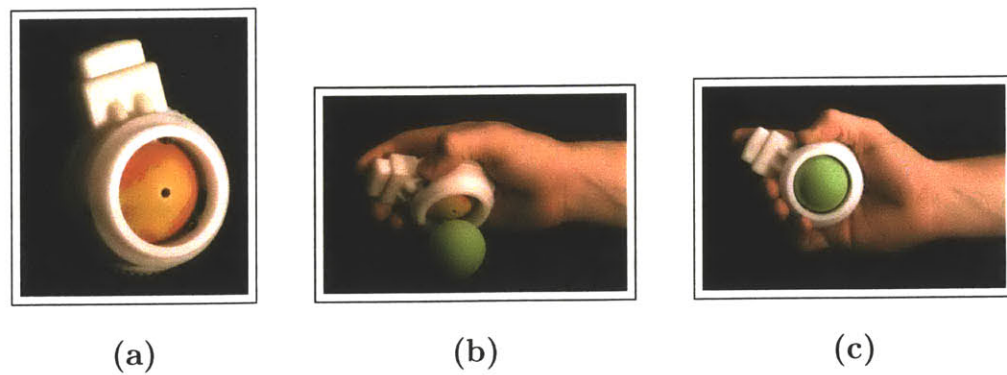

Figure 4-15: 2nd Iteration of the Hand Popper with Cylindrical Channel

Popper assume the cylindrical channel in place of the cone channel.

The second iteration of the Hand Popper is shown in Figure 4-14 with a flared cone channel and Figure 4-15 with the cylindrical channel. This prototype was a vast improvement over the first iteration in both performance and aesthetics. The team and the sponsor, however, agreed that the amount of force required in loading this device was still too high and too variable. In order to bring the concept to market, the popping mechanism needed to be analyzed at a higher level and the team needed to determine a means of reducing the required loading force. These topics are addressed in refining the concept.

## 4.2 Refining the Concept

In the refinement stage, the team analyzed the physics and form of the hopper popper as a means to improve upon the higher level prototypes of the previous section. High speed photography was used to determine forces and motion paths involved in Hopper Popper Activation. The collected information was then used to redesign and enhance the most promising hopper popper related concept, the Hand Popper. This section documents means of lowering the loading force, the Hand Popper final iteration, and its comparison to the state of the art.

### 4.2.1 Understanding the Popper

The greatest issues of concern in Hopper Popper Activation are the required loading forces and Kinetic Energy Density limit. The team was able to address these issues with a greater understanding of the physics and motion path of the hopper popper.

#### Loading and Triggering Forces

The team found two varieties of the 2.2 *in* diameter hopper poppers used in this research. The more common variety, colored in red and yellow, is much stiffer, harder to invert, and transmits more energy into a ball. A second, green and yellow variety, formed from a rubber with a lower durometer but identical in size and shape, is softer, much easier to invert, and transmits less energy into a ball. In addition, there is a slight range of stiffness within both varieties. Both varieties and their variances are taken into account throughout the analysis presented in this section.

The team quantified the loading force as a means of comparison to the Nerf<sup>®</sup> Ball Blaster<sup>™</sup> (the most similar product on the market) and for later comparison to the final design. Loading and triggering forces were determined for the following:

- Original Sketch Model
  - With Soft Popper and Ball Aligned with Center of Popper
  - With Soft Popper and Ball Misaligned from Center of Popper

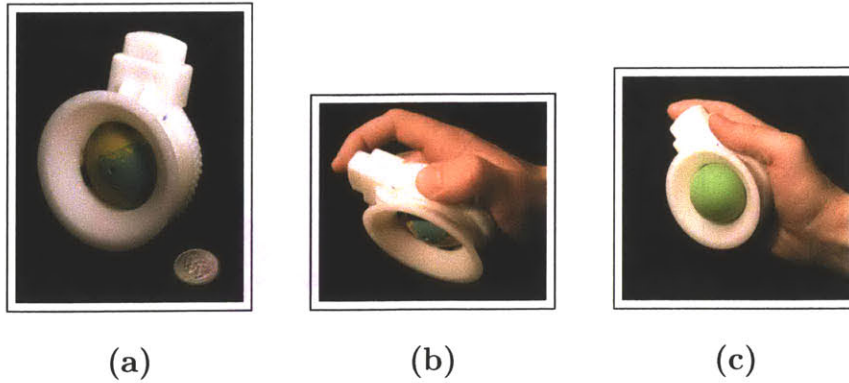

Figure 4-14: 2nd Iteration of the Hand Popper with Flared Channel

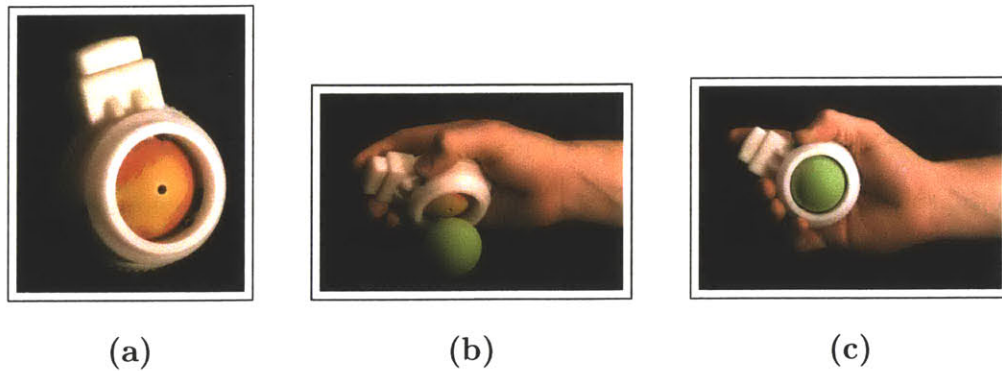

Figure 4-15: 2nd Iteration of the Hand Popper with Cylindrical Channel

Popper assume the cylindrical channel in place of the cone channel.

The second iteration of the Hand Popper is shown in Figure 4-14 with a flared cone channel and Figure 4-15 with the cylindrical channel. This prototype was a vast improvement over the first iteration in both performance and aesthetics. The team and the sponsor, however, agreed that the amount of force required in loading this device was still too high and too variable. In order to bring the concept to market, the popping mechanism needed to be analyzed at a higher level and the team needed to determine a means of reducing the required loading force. These topics are addressed in refining the concept.

- With Hard Popper and Ball Aligned with Center of Popper
- With Hard Popper and Ball Misaligned from Center of Popper
- Hand Popper (1st Iteration)
  - With Soft Popper and Ball Aligned with Center of Popper
  - With Soft Popper and Ball Misaligned from Center of Popper
  - With Hard Popper and Ball Aligned with Center of Popper
  - With Hard Popper and Ball Misaligned from Center of Popper
- Hand Popper (2nd Iteration with the cylindrical channel for ball alignment)
  - With Soft Popper
  - With Hard Popper
- Nerf® Ball Blaster™

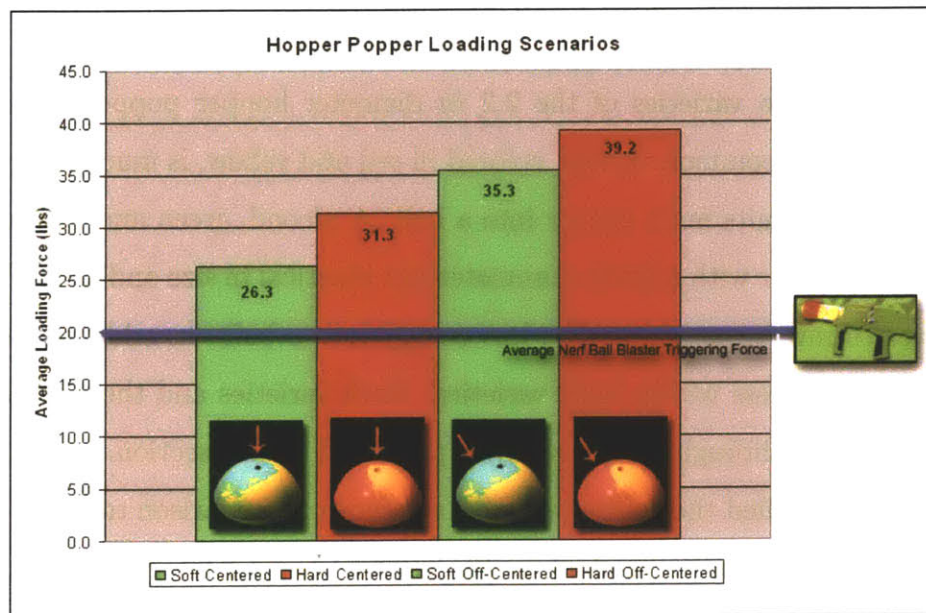

Figure 4-16: Average Loading Forces for Various Popper Scenarios

All prototypes were tested using both soft and hard varieties of hopper popper. The loading force when applied aligned (centered) and misaligned (off-centered) was

second high-level iteration of the Hand Popper had a decrease in required loading force of 15%. This reduction was a result of the addition of the cylindrical channel for centering the ball. As shown, the required loading force of the Hand Popper was still 30% higher than the triggering force of the current Nerf<sup>®</sup> Ball Blaster<sup>™</sup>. Means of further lowering the loading force are addressed in later sections.

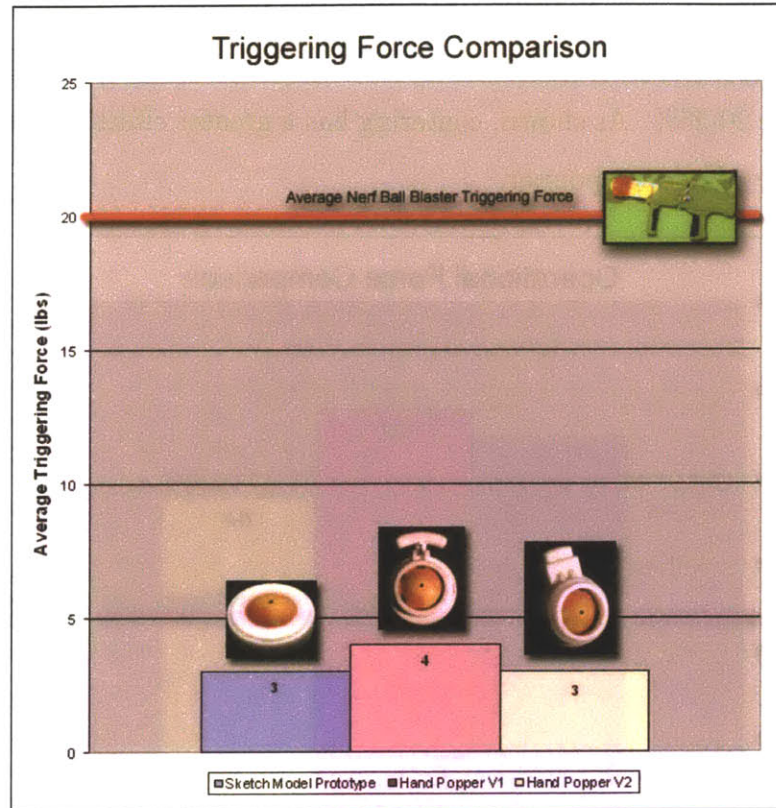

Figure 4-18: Average Triggering Force Comparison

Although the loading force is comparatively high, the force required to trigger is an order of magnitude lower than that of the current Nerf<sup>®</sup> Ball Blaster<sup>™</sup>. Figure 4-18 shows the average triggering force for the different Hand Popper Prototypes as well as that of the Nerf<sup>®</sup> Ball Blaster<sup>™</sup>. It is much harder for the user to control the toy when applying a large force. The Hand Popper, although harder to load than the Nerf<sup>®</sup> Ball Blaster<sup>™</sup>, gives the user much more control when firing.

In an attempt to decrease loading force, the team experimented with drilling equally spaced holes around the body of a popper. The holes were added to weaken

the structural integrity of the popper and allow for easier inversion. Several different patterns of holes, shown in Figure 4-19, were tested; however, the required loading forces did not change significantly. The team opted to analyze the motion path to redesign the popper holder for easier loading. This is explained later in the following section.

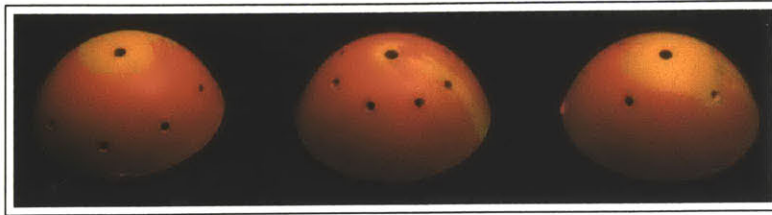

Figure 4-19: Hole Patterns Created in Poppers

### High Speed Imaging

This section documents the high speed photography used in analyzing the hopper popper. The team used the high speed images to determine the velocities and energies related to the hopper popper and launched foam balls. The team overlaid high speed images to determine the motion path of an inverting hopper popper.

The team used a Redlake MASD Ektapro High Speed Video camera from the Edgerton Center at MIT. The camera recorded 256 gray scale black and white digital image data at 1900 frames per second with a resolution of 512x1024 pixels. This resulted in 526 microseconds between frames with a  $100 \mu s$  exposure. The low time of exposure in high speed photography required extreme lighting. The team used two 1000 *Watt* spotlights to illuminate the hopper popper testing assembly. To record the exact changes in position two rulers were positioned horizontally and vertically in frame.

The team analyzed the hard (red) hopper poppers to determine the maximum energies involved in the system. The following scenarios were captured on film for analysis:

- Hard hopper popper inverting

- Hard hopper popper unconstrained launching a foam ball
- Hard hopper popper constrained (with a high level prototype device) launching a foam ball

The team first recorded footage of an unconstrained popper inverting. The team captured still frames from the video to determine the velocity of the popper leaving the surface. Using the known time between frames of  $526 \mu s$  the average initial popper velocity was calculated to be  $6.2 \text{ m/s}$ . Figure 4-20 shows the still frames of the popper accelerating upward. This initial velocity was used to calculate a maximum vertical height of  $2.0 \text{ m}$  neglecting air resistance. To support this calculation the team physically measured the average height of twelve hard poppers to be  $1.9 \text{ m}$  with a standard deviation of  $.1$ . This observed measurement takes into account air resistance as well as the variation in popper stiffness. The team then used the experimental maximum height to determine the maximum energy stored in a hard popper to be  $.4 \text{ J}$ .

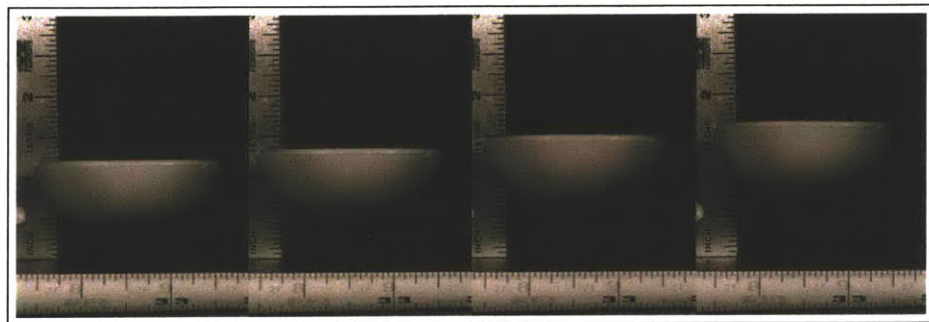

Figure 4-20: High Speed Photography of the Popper Accelerating Vertically

Finding the maximum energy imparted into a ball was crucial for determining if the toy exceeded the allowable Kinetic Energy Density provided in the standards and safety section. The team recorded footage of a foam ball being launched from both a constrained and unconstrained popper. The constraining device was the popper holder implemented in both high-level Hand Popper iterations referenced in the Detailed Design section. Still images were captured to determine the average initial ball velocities launched from constrained and unconstrained hard poppers. Using the

known time between frames of  $526 \mu s$ , the average initial ball velocity was calculated to be  $12.1 \text{ m/s}$  constrained and  $13.3 \text{ m/s}$  unconstrained. Still frames of these two scenarios are shown in Figure 4-21 and Figure 4-22. Ignoring air resistance, a foam ball can reach a vertical height of  $7.5 \text{ m}$  from a constrained popper and  $9 \text{ m}$  from an unconstrained popper. On average, a constrained popper compared to an unconstrained popper restricted the distance a ball travels by almost 17%. Part of this reduction was from the rubber gasket tabs used to hold the ball inside the popper device. Comparing the original ball height measurements in the Prototyping Section, it is apparent that air resistance on the foam ball is significant. With air resistance, the average height is decreased by half.

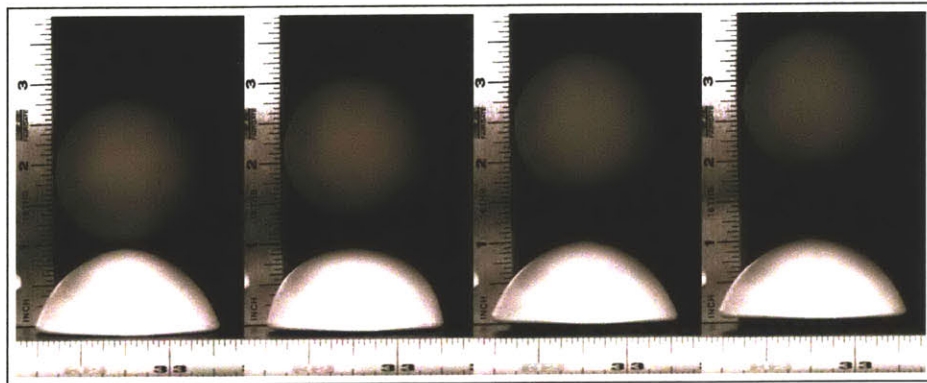

Figure 4-21: High Speed Photography of an Unconstrained Popper Launching a Foam Ball

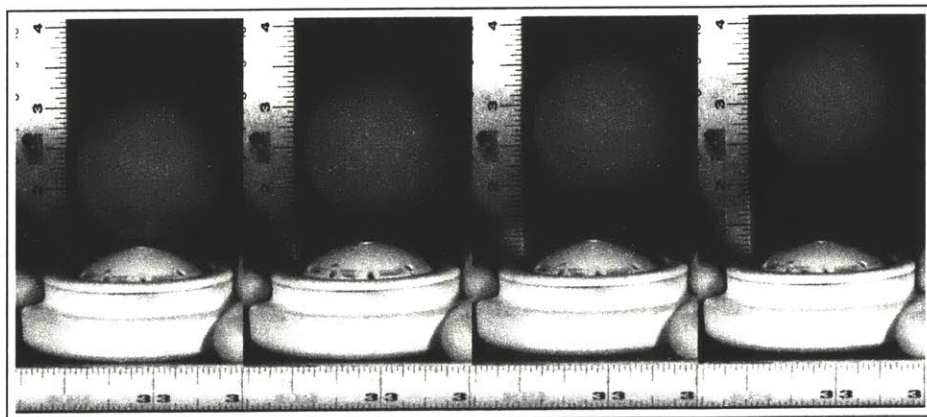

Figure 4-22: High Speed Photography of a Constrained Popper Launching a Foam Ball



The team used the unconstrained calculated initial ball velocity ( $13.3 \text{ m/s}$ ) to determine the maximum energy imparted into the ball to be  $.38 \text{ J}$ . To find the maximum Kinetic Energy Density, the team needed to measure the contact area of the projected ball from an unconstrained popper. The procedure suggested by the sponsor involved staining and firing the ball from the mechanism at a distance of  $1 \text{ ft}$  from a surface (explained in further detail in Appendix A). The residual marking area left on the surface from the stained ball was measured as the contact area of the projectile. Six different poppers of different strengths were tested. The residual marking areas are shown in Figure 4-23. The average area was measured to be  $500.00 \text{ mm}^2$  for a foam ball. The maximum Kinetic Energy Density of hopper popper activation was then calculated to be  $759.37 \text{ J/m}^2$  which is less than half the maximum allowable  $1600 \text{ J/m}^2$ .

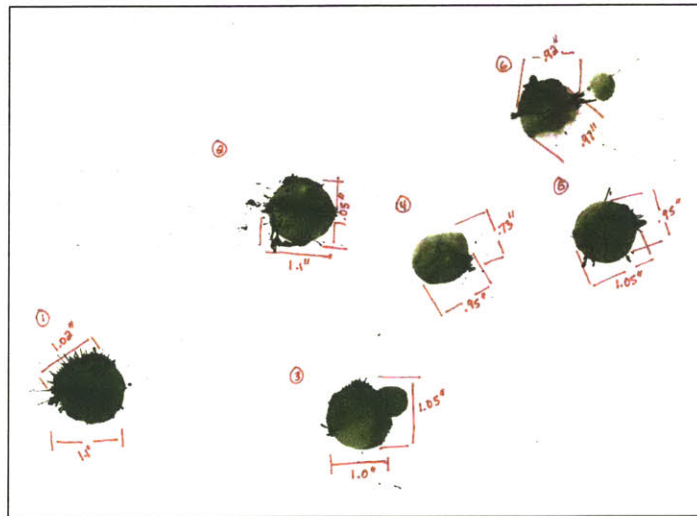

Figure 4-23: Residual Markings from Impact Testing

In order to determine the motion path taken by an inverting popper, the team overlaid still frames taken from two different experiments. Figure 4-24a shows an unconstrained hard popper inverting from an initial position of rim on the surface. Figure 4-24b shows an unconstrained hard popper inverting in the opposite direction with a foam ball. This second figure better represents the orientation used in the popper devices to launch balls. The team now had a clearer understanding of the motion

path taken by a transitioning unconstrained popper. The team inferred from these images that an unconstrained popper should be easier to invert than a constrained popper. Simple testing by hand supported this theory.

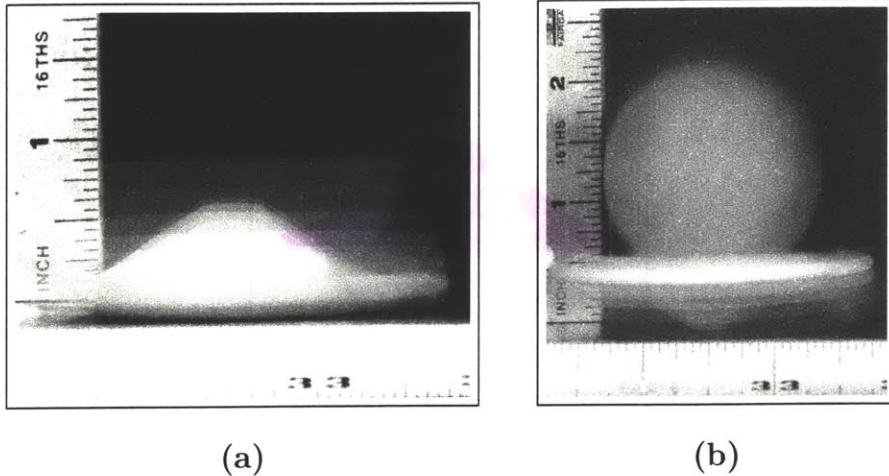

Figure 4-24: Motion Path of Popper

Through the experiments presented in this section, the team uncovered four important factors which were implemented in finalizing the design. The team found from the loading and firing force analysis that a soft popper material and centering the ball before loading both decreased the required loading force. From the high speed motion study, the team found that an unconstrained popper projected a ball a significantly greater distance and should be easier to load than a constrained popper. The team determined the exact motion path taken by an inverting popper. This path was used in a redesign.

#### 4.2.2 Means of Lowering the Loading Force

The team found from observations in high speed photography that an unconstrained hopper popper was more efficient in firing. The team found that a popper should require less force to invert if it follows an unconstrained motion path. These key findings resulted in the generation of an unconstrained popper inverter, an elastically constrained popper, and a low friction Hand Popper. Both the elastic constraint and low friction designs were successful in lowering the loading force. The low friction

design was chosen as the final design, being the simplest and most effective.

### Unconstrained Popper Inverting Mechanism

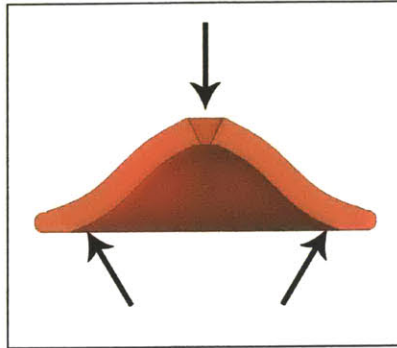

Figure 4-25: Means of Inverting Popper with Less Force

The team's first attempt to create an unconstrained Hopper Popper Activation system involved a mechanism that applies an inverting force normal to its inherent path of motion at all times. In previous designs related to the popper, the base was constrained while a force was applied to the top. The team found that the popper inverts with less force when the popper is stretched at the base while being pressed at the top, as shown in Figure 4-25. The team developed a mechanism which reproduces this effect.

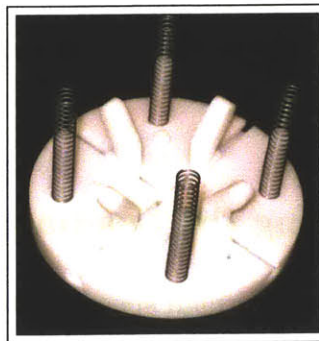

Figure 4-26: Fingers Guided on a Track

The basic stretch-to-invert mechanism utilized four equally spaced finger-like tabs that pull outward at the inner base of the popper. These fingers applied a force normal

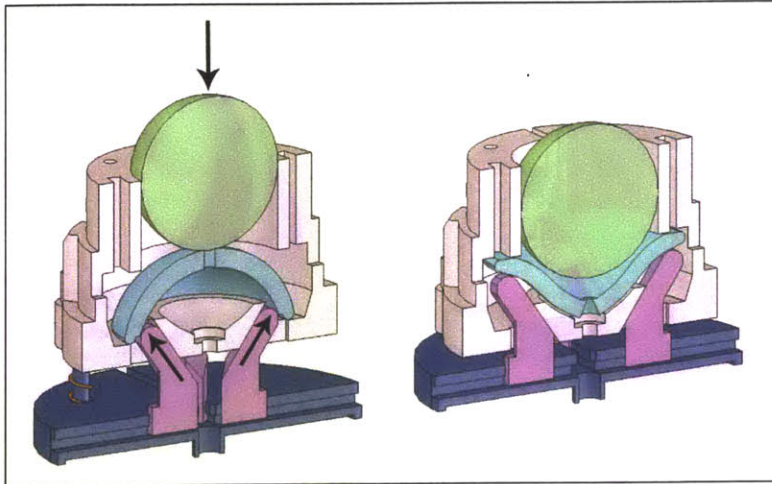
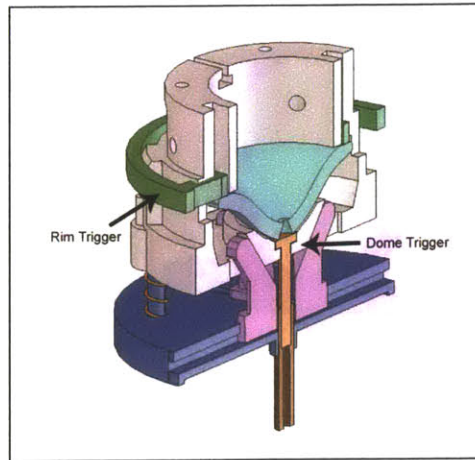

Figure 4-27: Loading Motion of a Cross-Sectioned Unconstrained Holder

to the popper motion as a foam ball is pressed into the dome of the popper. The team chose to guide the fingers on a track shown in Figure 4-26 and have a popper housing which slides on posts perpendicular to the track. The fingers are constrained to a second track inside the housing which guides the path of motion. As the housing slides down, the fingers slide outward inverting the popper. This motion is shown in the cross sections in Figure 4-27. Springs were needed on the track posts to return the housing and fingers to their original position after the popper is inverted.

The team designed two alternative triggers, shown in Figure 4-28a, to activate the inverted popper. The first trigger places a force onto the rim of the inverted popper. The second trigger is a post similar to the previous designs which push the inverted popper at the inverted dome. This post, however, presses the back of the popper dome instead of the side.

The completed SLA design, shown in Figure 4-28b did not function as expected as a result of multiple locations of jamming. The high static friction of SLA material on itself was unfit for this prototype as the design relies heavily on sliding parts. In addition, the size and complexity of the mechanism was unfit for application to the Hand Popper; however, it was well suited for a Shotgun Ball Blaster™ concept. The team decided to explore simpler means of inverting the hopper popper with less constraint.



(a)



(b)

Figure 4-28: The Unconstrained Popper Mechanism

### Elastic Constraint

The team decided that an elastically constrained system would be simpler to implement than an unconstrained system, and would provide better results. The concept involved suspending the hopper popper in a very soft rubber within a holder. This design is more suitable for adaptation to the Hand Popper than the unconstrained inverting mechanism.



Figure 4-29: Wax Mold Used to Create an Elastic Holder

Having the popper suspended in a soft rubber allowed for support, and in addition, allowed for a relatively free range of motion. Inverting a popper within a soft rubber casing should reduce the force required to load. To test the concept, the team

produced silicone castings for popper suspension. A two-piece mold was needed to cast the silicone. Using hard machining wax, the team created a mold, shown in Figure 4-29. The mold was designed to cast a silicone ring around a non-inverted popper. The ring was to extend a short distance above and below the popper rim to secure the popper inside. The wall thickness of the silicone ring was a critical design parameter. The popper rim diameter expands .4 *in* radially when transitioning to an inverted state. The silicone ring outer diameter had to be larger than the inverted popper diameter to allow room for elastic deformation of the silicone ring when inside a rigid holder. The cross-sectioned silicone ring is shown in Figure 4-30.

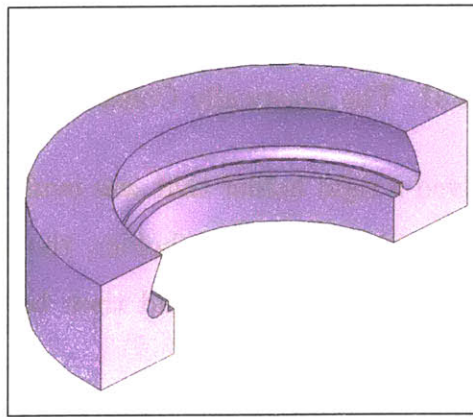

Figure 4-30: CAD Cross-Section of the Casted Silicone Ring

A soft, two-part mold making rubber silicone with a durometer of 30 was used to mold the ring. The popper encased in the silicone ring is shown in Figure 4-31a. Loading a foam ball into the silicone encased popper, as shown in Figure 4-31b, required on average 20 *lbs* of force, which is the average required triggering force of the Nerf<sup>®</sup> Ball Blaster<sup>™</sup>. These measurements were taken without harnessing the band inside a rigid holder. If the silicone ring was secured inside a rigid holder, the loading force should increase as applied force goes into compressing the silicone ring inside the walls of the holder while the popper inverts and expands radially. The resulting loading force should fall between the unrestricted 20 *lbs* and the current loading force of approximately 30 *lbs*. Upon testing, the team found the loading force of the silicone encased popper inside a press-fit rigid holder to be approximately 28

*lbs.* The team brainstormed three means of harnessing the elastic popper support in such a way to prevent the loading force from increasing over 20 *lbs.*

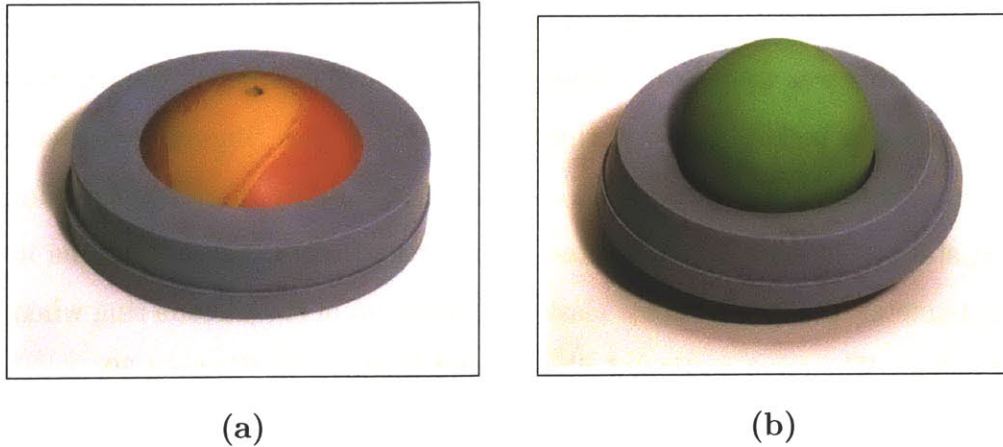

Figure 4-31: The Elastically Constrained Popper

The first concept involved a rigid holder that was ovular in shape. When placing the silicone encased popper inside the ovular holder, the harness would distort the popper initially. The compressed popper would then be easier to invert. Simple testing disproved the idea.

The second concept involved molding the entire Hand Popper device out of silicone. The loading force should remain at 20 *lbs.* An additional stiff retainer ring would be needed as a mold insert, as the silicone ring was not capable of ball retention. This method was a promising means of creating a simple, one piece Hand Popper with low loading force; however, more research and development would be needed. The triggering method would most likely revert back to the original palm activation.

The third concept involved extending the rim of the hopper popper into a rubber skirt, as shown in Figure 4-32. The skirt acts as a lever arm and gives the user a mechanical advantage in loading as a lower force is applied over a longer distance. In this concept, the skirt edges would be clamped to a rigid support. The skirt will increase the overall size of the mechanism, rendering it unsuitable for use in the Hand Popper. This concept, however, can be applied to a Ball Blaster™ type of toy.

The elastically constrained designs were effective in reducing the loading force in

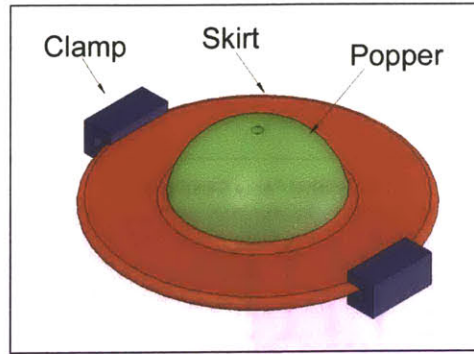

Figure 4-32: Rubber Skirt Extending from the Popper Rim

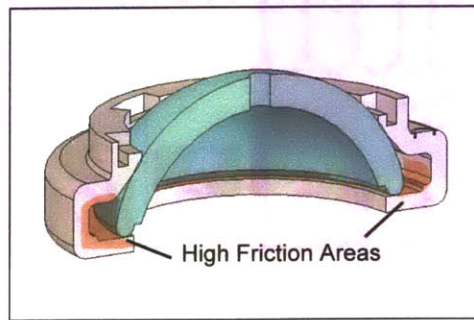

Figure 4-33: High Friction Areas inside the Popper Holder

part due to the low contact friction (and almost none in the case of the skirt concept). The high loading forces associated with the past Hand Popper iterations as well as the original popper holders were a result of the contact friction involved between the rubber popper lip and the inside of the plastic holder, as shown in Figure 4-33. This is another explanation on why the SLS Hand Popper of the first Iteration had a larger loading force than the delrin sketch model and the SLA second iteration. The SLS material is much rougher than delrin and the SLA material. The team then looked into means of lowering the friction of the second Hand Popper iteration.

### Low Friction

To test the concept, the team placed talcum powder inside the popper holder of the second iteration Hand Popper. The addition of the dry lubricant lowered the average force required to load by approximately 35% to an average of 18 *lbs*. As shown in Figure 4-34, the Low Friction Hand Popper required less operational force than the



current Nerf<sup>®</sup> Ball Blaster<sup>™</sup>.

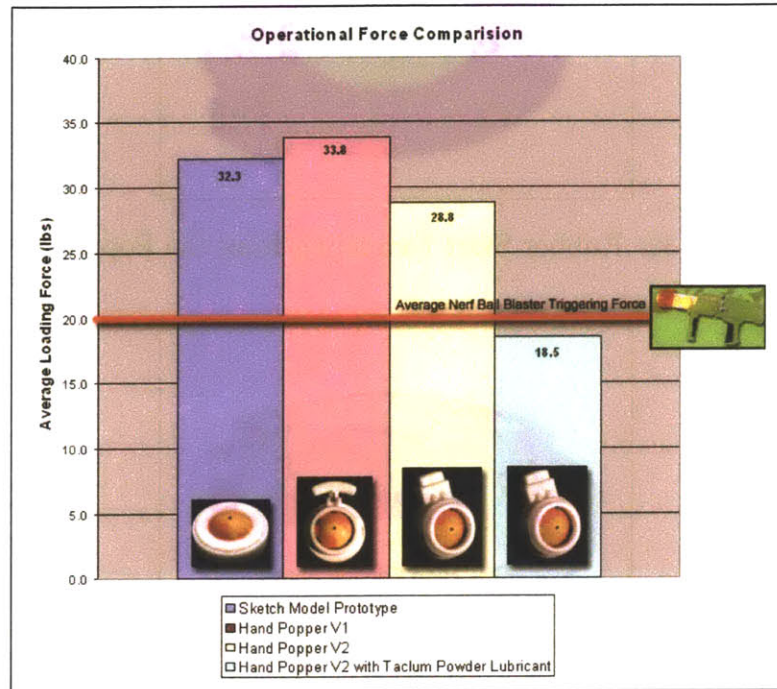

Figure 4-34: Operational Force Comparison

In firing, the dry lubricant allowed the popper to operate as if it was completely unconstrained. As shown in Figure 4-35, a foam ball launched vertically from the Low Friction Hand Popper reached comparable heights as a foam ball launched from an unconstrained hopper popper. The Low Friction Hand Popper also outperformed the Nerf<sup>®</sup> Ball Blaster<sup>™</sup> in range by approximately 20%.

Future work can involve implementing ball bearings into the design in place of the dry lubricant. The bearings would provide a cleaner and longer lasting solution with the possibility of an even lower loading force. Bearings, however, would be more expensive. Other research could involve low friction coatings for the rubber popper or holder. With the given time constraints, the team used the dry lubricant in the Final Hand Popper Iteration as a means of lowering the required loading force.

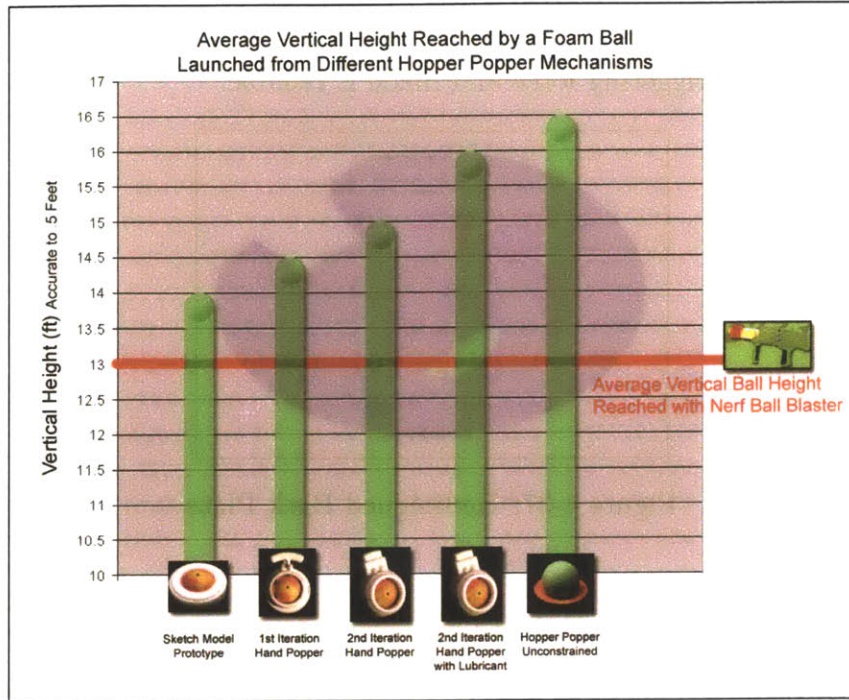

Figure 4-35: Vertical Distances Achieved by Foam Ball Launched with Various Mechanisms

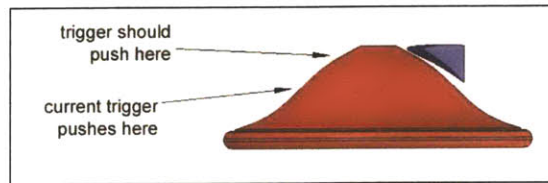

Figure 4-36: Adjusting the Trigger/Popper Contact Location

### 4.2.3 Final Hand Popper Iteration

The team had to make several modifications on the second Hand Popper iteration to make it more reliable in firing. In the second iteration, the trigger presses the side of the popper. Occasionally, this pinched the popper against the back plate and delayed the firing until the trigger force was removed. The addition of the talcum powder reduced this occurrence; however, the team redesigned both the trigger and the raised bump on the back plate. The redesigned trigger was adjusted to press the very top of the inverted dome as shown in Figure 4-36. The trigger extension also secured the trigger within the body of the Hand Popper. The raised bump was enlarged and

also shifted to touch the top of the inverted dome. Altering the trigger and bump lowered the required triggering force and made it reliable.

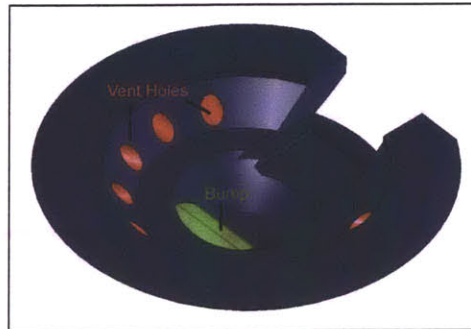

Figure 4-37: Redesigned Back Plate

In the second iteration, conical and cylindrical loading channels were tested and the cylindrical channel ensured on-center loading which was important in lowering the loading force. This cylindrical channel was incorporated into the Hand Popper body in this third iteration. The ball screw method of ball retention was also incorporated into this third iteration as it is a means of finely tuning the amount of retention force. The ball screws are still required in this iteration because of uncertainties in rapid prototyping tolerances.

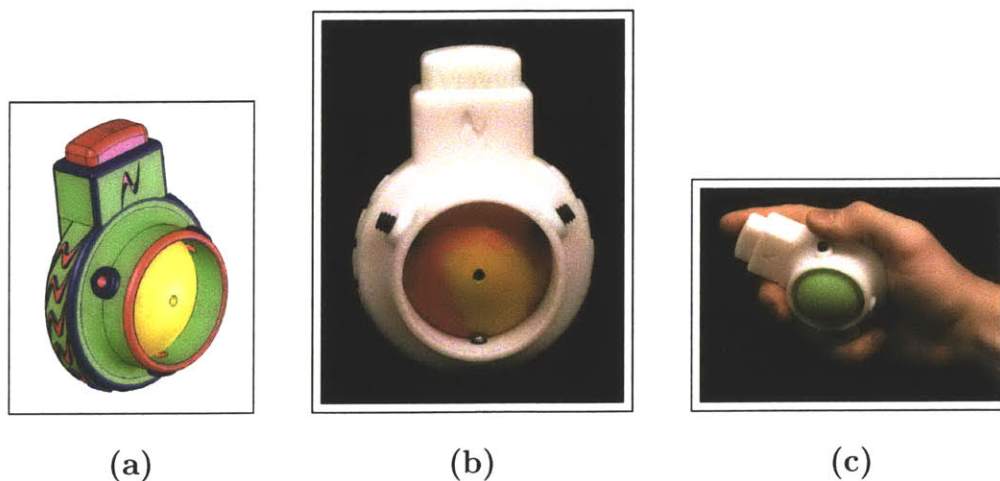

Figure 4-38: Final Iteration of the Hand Popper

The team decreased the size of the back plate to allow the Hand Popper to fit in hands of all sizes. The redesigned back plate is shown in Figure 4-37. The back plate

vent holes were enlarged to allow air to flow more easily when the popper inverts. The back plate was redesigned to contour into the trigger housing as well as the popper housing. The raised grip around the housing was also redesigned to incorporate a new suggested Nerf® logo. The final Hand Popper Iteration is shown in Figure 4-38.

### Suggestions for Manufacturing

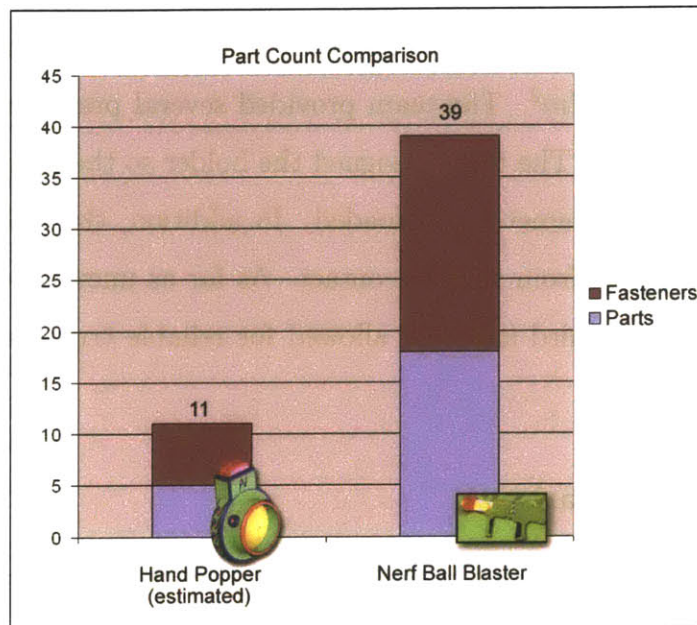

Figure 4-39: Number of Parts Comparison

In manufacturing the Hand Popper, the team determined that the body would be plastic injection molded in two pieces. The back plate would be incorporated into the body. This division allows for the easy insertion of the hopper popper and the trigger. Most likely, four fasteners (screws) are needed to attach the two body halves. The trigger, also plastic injection molded, would be made in one piece (including the spring guide post) instead of the prototyped three-piece design. The ball screws will be replaced with raised bumps incorporated into the injection mold of the body. The manufactured Hand Popper would be composed of the following eleven parts: Two body halves, the hopper popper, the trigger, a return spring, and six fasteners (screws). Figure 4-39 compares the suggested number of parts in the Hand Popper

to that of the Ball Blaster™. Future work could involve the manufacture or redesign of the hopper popper itself.

## **Safety**

There are three pertinent safety issues regarding the Hand Popper: The Kinetic Energy Density limit, firing of foreign objects, and unexpected discharge. The Kinetic Energy Density was found to be well under the allowable  $1600 J/m^2$ . The maximum possible Kinetic Energy Density attainable using an unconstrained hard popper was found to be  $759.37 J/m^2$ . The team provided several preventative measures in launching foreign objects. The team designed the holder so the popper only remains inverted with a specific diameter ball loaded. In addition, the loading channel encloses the hopper popper from surface contact. As far as unexpected discharge, the alterations made in the third iteration allowed for reliable triggering of the hopper popper.

## **State of the Art Comparison**

The Hand Popper has many advantages over the projectile toys on the market. Its size allows for concealment, which is a novelty in the area of foam ball launching toys. Its design allows for quick loading off of surfaces or directly from the hand. The concept is simple and easy to manufacture. A downside to the Hand Popper is that it can only store and fire one foam ball at a time as compared to the other ball launching toys on the market. The concept of using a small rubber spring as a means of storing energy can be applied to almost any projectile toy and possibly ones involving multiple-ball ammunition.

The final Hand Popper iteration is compared to the Nerf® Ball Blaster™, Figure 4-40, being the most similar product on the market. As shown in Figure 4-34, the Hand Popper with dry lubricant requires an average of 1.5 *lbs* less force to operate than the Ball Blaster™. As shown in Figure 4-35, the Hand Popper is capable of firing 20% further than the Ball Blaster™. In comparing only triggering forces in Figure 4-18, the Hand Popper requires much less force than the Ball Blaster™ giving

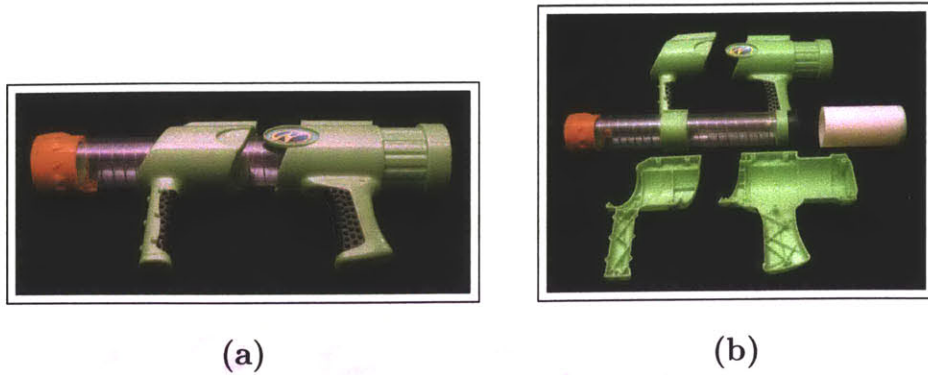

Figure 4-40: The Nerf<sup>®</sup> Ball Blaster<sup>™</sup>

the user more control during firing. As shown in Figure 4-39 the Hand Popper can be manufactured with a much lower number of parts than the Ball Blaster<sup>™</sup>.

### 4.3 Summary

Hopper Popper Activation was proven to be an effective means of launching foam balls. As shown in Figure 4-41, the concept was originally applied to four different varieties of projectile toys: Blasters, Post Pickups, Hand Popper, and Grenade. The Grenade application diverged into a Stomp Grenade and a Radio Control Grenade; both were successful iterations. The Hand Popper concept, being the product with the highest potential, was also very successful and passed through two high level detailed design iterations to improve functionality and aesthetics. The greatest issue of concern in Hopper Popper Activation, and in particular the Hand Popper, was the amount of required force to load the toy. After thoroughly analyzing the physics and motion path of the hopper popper, several design suggestions were developed in a refinement stage. A final iteration was made incorporating a low friction means of reducing the loading force. This final Hand Popper iteration was capable of launching balls 20% further than the most similar product on the market while requiring a lower operating force.

## Hopper Popper Activation Evolution

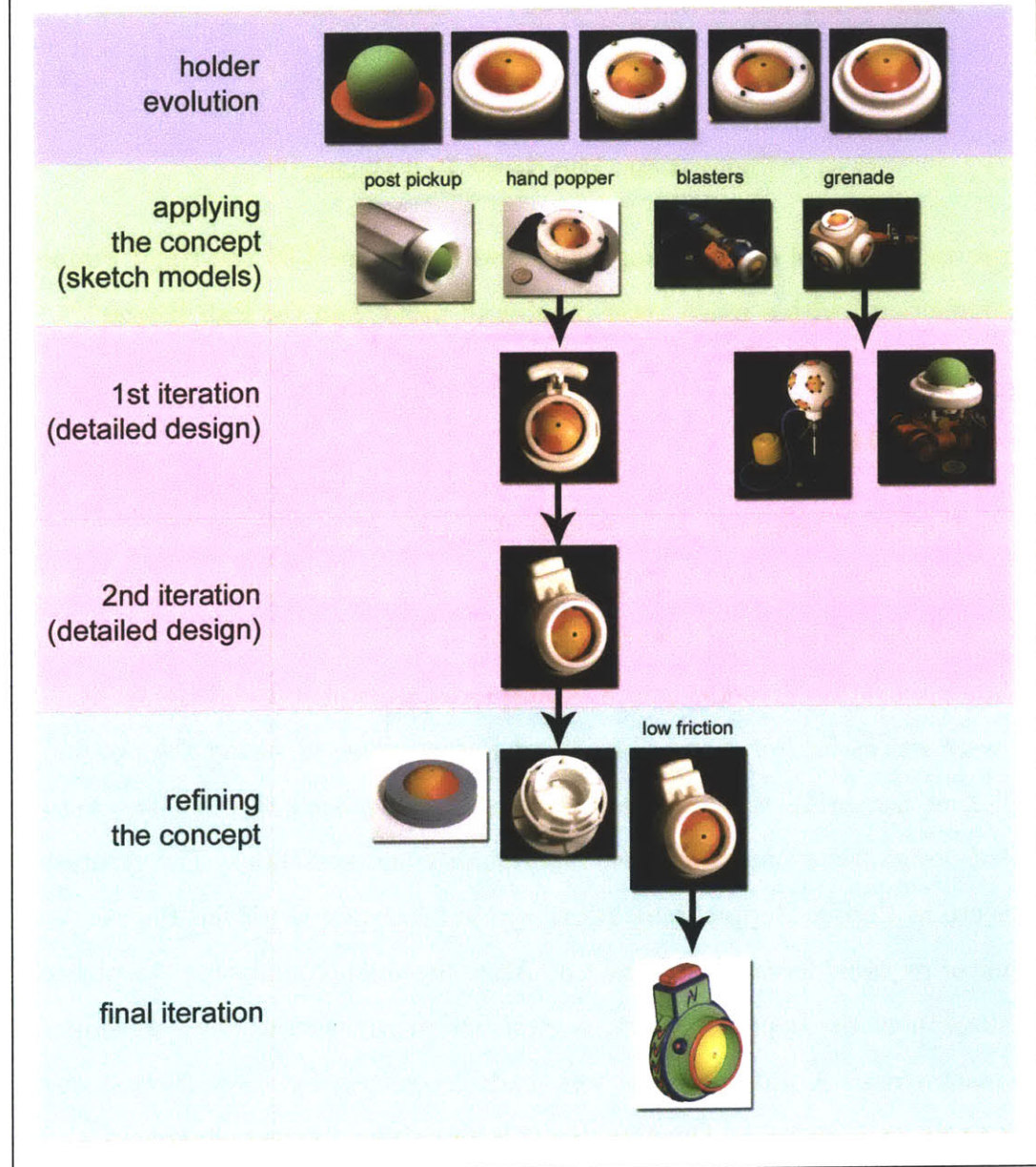

Figure 4-41: Hopper Popper Activation Evolution

# Chapter 5

## LED Darts (eDarts)

This section documents the detailed design and refining of the LED Dart concept renamed eDarts by the sponsor. The detailed design stage covers the enhancement of the sketch model prototype. The refinement stage covers the analysis of the eDarts, a suggested final design, and a comparison to the state of the art.

### 5.1 Detailed Design

There were several issues of concern with the eDart concept. The sketch model prototype required the darts to be loaded in a specified orientation to allow for the three-contact alignment. The contacts needed to be axially symmetric to allow for quick and simple loading independent of orientation. Safety was another issue of concern, as the sketch model prototype contained exposed sharp electric contacts not suitable for a projectile toy. In the detailed design stage, the team developed two higher level iterations on the LED Dart concept addressing these issues. The first involved the use of conductive paint as contacts. The second iteration was more reliable and used male audio plugs and customized female jacks. Both iterations made use of the Nerf<sup>®</sup> PowerClip<sup>™</sup> with alterations on the magazine.

The team considered six contact layouts prior to the higher level iterations detailed in this section. These layouts addressed the issue of axially symmetric loading. In some of these layouts, the team assumed the possibility of implementing a conductive



foam film on the exterior and/or interior of the dart. The use of conductive film required a reliable means of connection to the circuit.

Layout 1, shown in Figure 5-1a, uses three internal annulus contacts located at different depths inside the dart. This requires three matching contacts on the blaster-side located along a post (not shown in figure). This design is advantageous as all of the contacts are internal and thus much safer; however, the user must push every dart completely onto its post to keep the entire circuit from shorting.

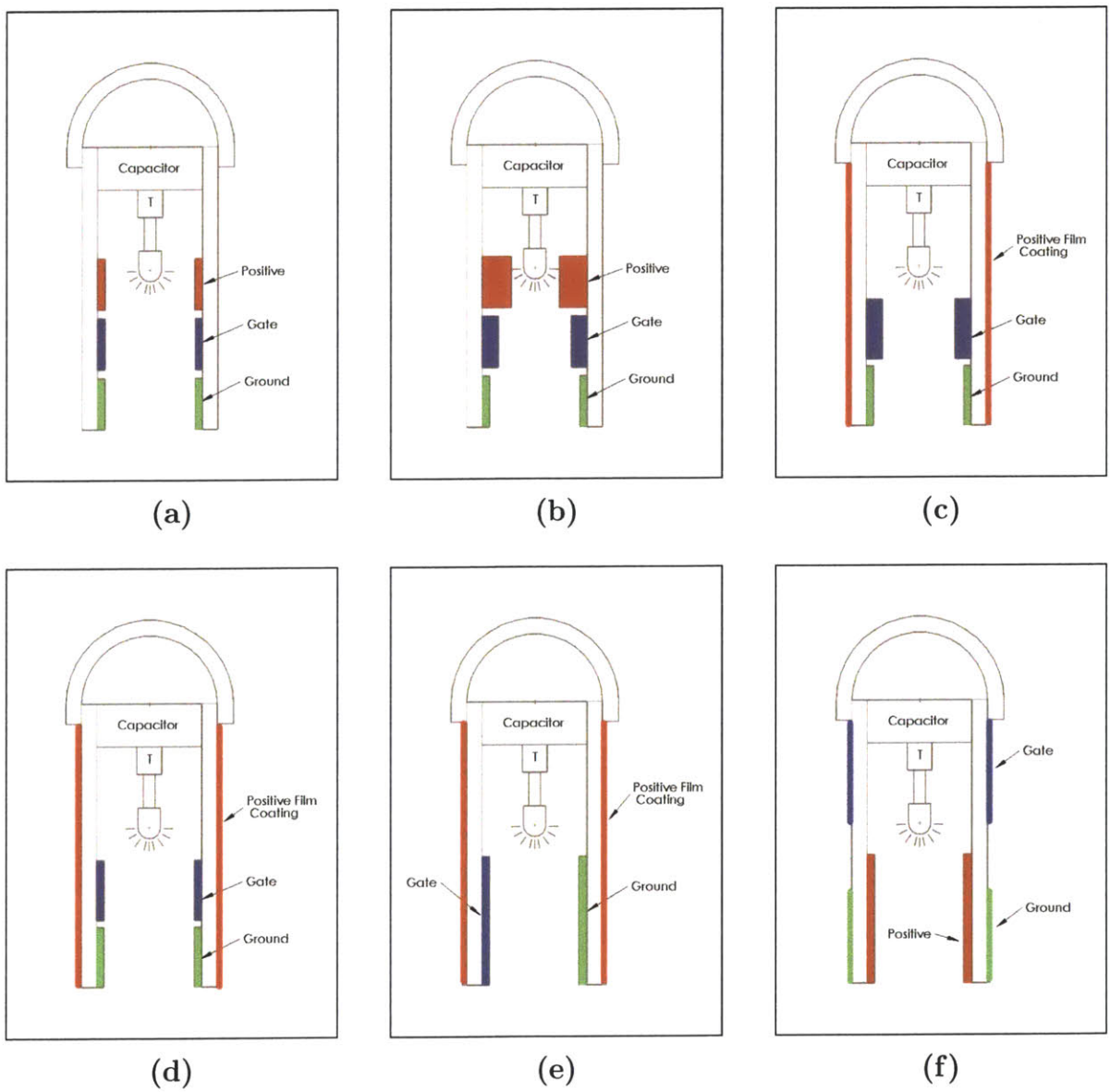

Figure 5-1: Various Dart Contact Layouts

Layout 2, shown in Figure 5-1b, is a similar layout as the former, but the three contacts are stepped at different radii. This design involved all internal contacts without the issue of shorting; however, it presented much complication in prototyping and manufacturing. In addition, the stepping interfered with the LED.

Layout 3, shown in Figure 5-1c, uses two internal step contacts and one external conductive film contact on the dart-side. This design is slightly less complicated to prototype and manufacture; however, it required a conductive film coating. The contacts on the blaster-side consisted of a male plug post with two contacts and a third contact on the inner wall of the barrel.

The team found that by transferring the resistor in the blaster-side of the circuit into the dart-side of the circuit only two contacts were needed in the blaster-side of the circuit. This is shown in the circuit of Figure 5-2. Although this design increased the weight of the dart by that of a resistor, this allowed for a more simple contact layout. Two contacts on the dart-side were now able to touch a common ground contact on the blaster-side. The following contact layouts make use of this alternative design.

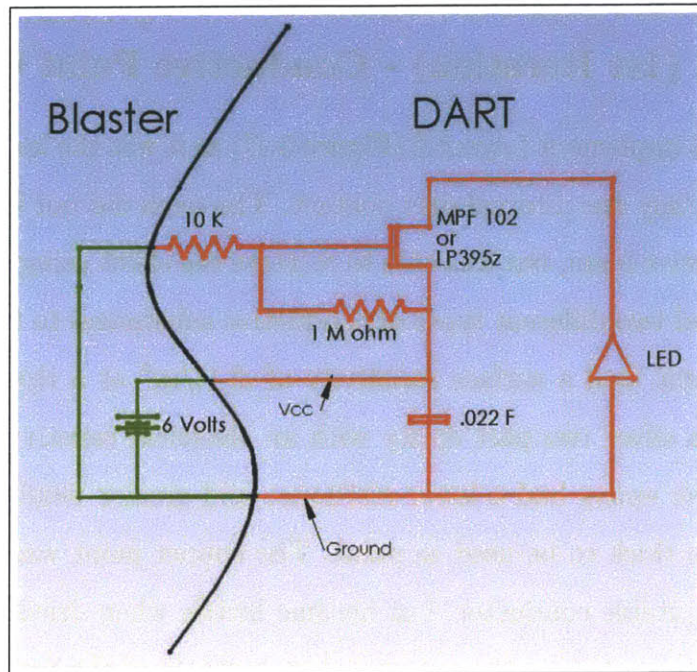

Figure 5-2: Redesigned Circuit with Two Blaster-Side Contacts

Layout 4, shown in Figure 5-1d, uses two annular internal contacts and one con-

ductive film coating as an external positive contact on the dart-side. The two internal dart contacts touched a common ground on the blaster post. This allowed for the removal of the steps and thus more internal room for an LED. Insulation is needed to bypass the first contact if the two annular contacts are at the same radii. A contact is also needed on the inner wall of the blaster barrel.

Layout 5, shown in Figure 5-1e, was similar to Layout 4, but two parallel strips replaced the two internal annular rings. With this design no insulation is needed to bypass a contact. The team found that annular contacts on the dart are not required if there are annular contacts on the blaster post.

Layout 6, shown in Figure 5-1f, uses one positive internal contact and two external contacts on the dart-side. The two external contacts can touch a common ground on the interior of the blaster barrel. This design requires custom conductive film layout on the exterior of the dart as well as a means of attaching the film to the dart.

The team determined that Layout 6 was the best suited design for a first iteration prototype. The following section details the implementation of this design.

### **5.1.1 eDart (1st Iteration) - Conductive Paint Contacts**

The team chose to implement Layout 6 (Figure 5-1f) as it was the least complicated to prototype having only one internal dart contact. The team did not have the resources to develop conductive foam, but was able to recreate the effect using conductive paint. The team procured two different types of conductive substances to test on foam. The first, a copper paint, had a surface resistivity of  $.3 \Omega/in^2$  at a thickness of  $.001 in$ . The second was a silver two part epoxy with an electrical resistivity of  $.003 \Omega/in^2$ . Although the silver epoxy had a lower resistance and greater flexibility, it was more expensive and too thick to be used as paint. The copper paint was easy to apply to foam and was a suitable conductor, but became brittle when dried. The team chose the copper paint to prototype the external dart contacts of the first iteration eDart.

The dart component layout was the same as that of the sketch model prototype with the addition of the 10K resistor relocated from the blaster. This additional resistor was placed next to the bleed resistor along the transistor shown in Figure

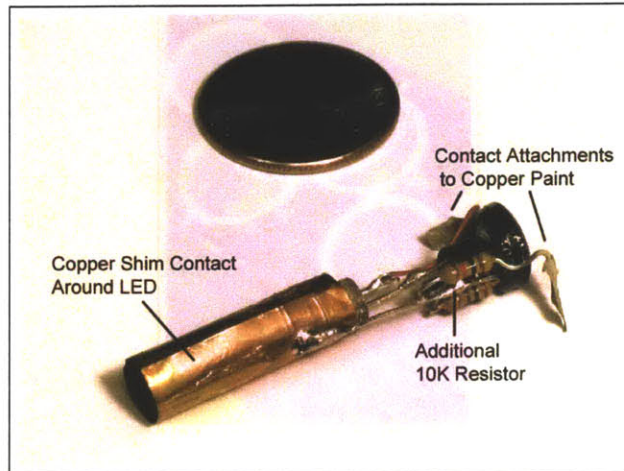

Figure 5-3: Revised Dart Component Layout

5-3. The team painted the two external dart contacts with copper paint following the configuration shown in Figure 5-4. The paint continued under the dart cap and onto the circuit contacts inside the dart. This layout allowed for no exposed metal contacts. The internal dart contact was composed of a tube formed from copper shim stock. The LED fit into the end of the shim stock tube which created a reflective light guide.

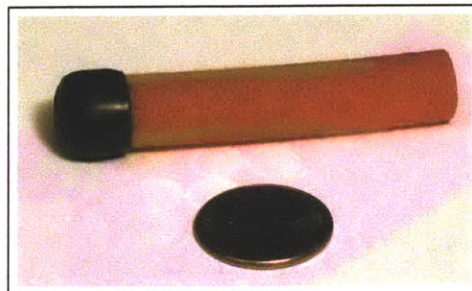

Figure 5-4: Painted Exterior Dart-Side Contacts

Two contacts were needed on the blaster-side shown in Figure 5-5; one along the post inside the barrel and one on the inner surface of the barrel. The team painted the inside of the barrels with the conductive copper paint. A wire was wrapped through a small hole in each barrel and was painted over to ensure conduction. All wires were led to the negative battery terminal in the top compartment of the magazine. The battery compartment had the same configuration as the sketch model prototype.

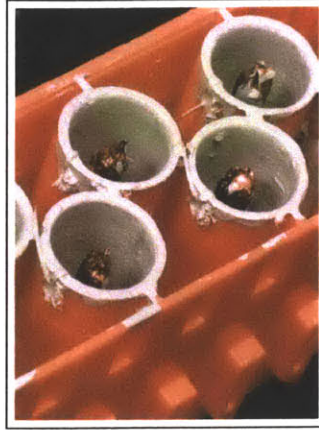

Figure 5-5: Two Contacts on the Blaster Side

In this prototype, the posts were left in the magazine but shortened to 1.75 *in* to not interfere with the internal dart components. The clip was cut down to allow for easy assembly of the posts. Wire was soldered to copper shim which was glued around the entirety of the post. All post wires were led around the barrel bottoms and to a common positive terminal in the battery compartment. The final clip is shown in Figure 5-6.

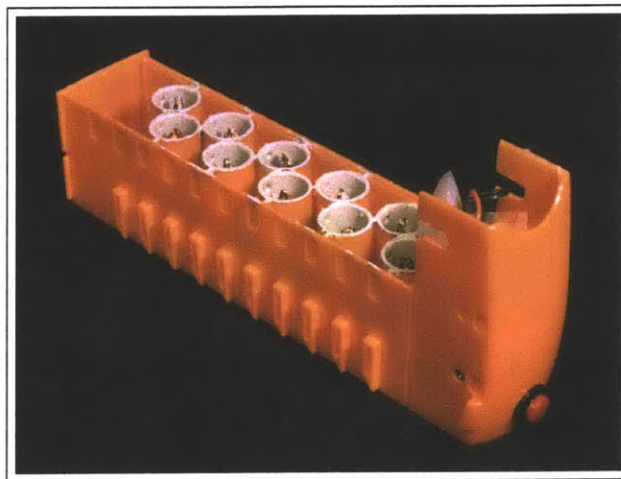

Figure 5-6: Final 1st Iteration Clip

At first the conductive paint on the exterior of the dart was not making sufficient contact with the conductive paint on the barrel interior. Extra coatings of paint were needed which increased the friction and made the darts heavier. These efforts along

with the shortening of the magazine barrels and the weight of the internal dart circuit decreased the distance of dart travel. This iteration was mildly successful and worked until the brittle conductive paint on the flexible foam darts began to chip and peel off. If manufactured, the conductive foam film would be more reliable assuming the two-strip orientation can be achieved. In addition, the connection between conductive paint and the dart components was not reliable, especially after multiple impacts. The team chose to approach the eDarts in a different manner.

### **5.1.2 eDart (2nd Iteration) - Stereo Connection**

The team decided to combine elements of contact Layouts 1 and 5 to create an all-internal-contact eDart iteration. A design with all internal components is safer for the user and easier to manufacture and implement with the current darts. A solid internal contact insert is also more robust than a conductive film or paint which can wear after use. The team prototyped four different types of eDarts in this iteration: Back Illuminating, Impact illuminated, Front Illuminating, and Alternating Color Blinking. The team decided to redesign the entire magazine of the PowerClip™ to allow for wire channeling, internal electrical housing, and a new post design.

#### **Contact Redesign**

The team began with a 1/8 *in* stereo plug, shown in Figure 5-7, as the male contact on the blaster-side. This type of connection was chosen for its axial symmetry and slender shape suitable for adapting to the blaster posts. A mono plug could have been used as only two contacts are required on the blaster-side; however, stereo plugs have longer shafts better suited for attaching to a post. The team considered using the 1/8 *in* stereo jack counterpart as the female contact in the dart, but the flexural contacts in the jack require a large force for disconnection. For the dart to fire adequately, there must be a low frictional resistance when exiting the barrel. The team decided that it was necessary to create a custom female jack to adapt to the 1/8 *in* stereo plug capable of low frictional resistance disconnection.

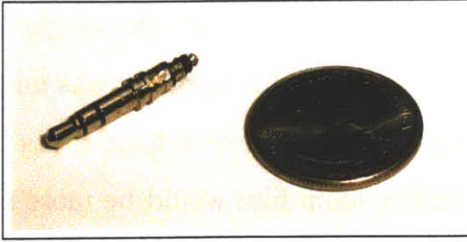

Figure 5-7: Standard 1/8 in Stereo Plug

Many factors contributed to the design of the custom female jack. The team needed to take into consideration size requirements, contact design and configuration, LED placement, and the location of the jack inside the dart. The jack needed to fit tightly inside the dart body and loosely adapt to the male 1/8 in stereo plug. The jack needed to be as light as possible, as the sketch model and 1st iteration did not contain this added weight.

The team chose to pair both the ground and the base on the dart-side to the second contact on the male plug. The positive contact on the dart was connected to the first contact on the male plug. This orientation is shown in Figure 5-8. The team designed a female jack insert that incorporated this three contact orientation. The most efficient means of producing a large quantity of eDarts was to SLA rapid prototype the inserts.

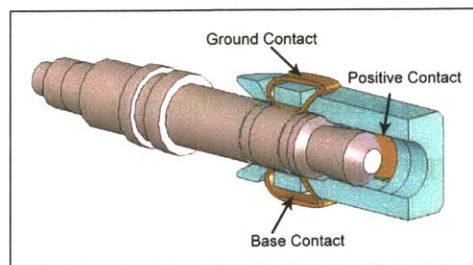

Figure 5-8: Revised Contact Orientation

The team considered two means of attaching contacts to the prototyped inserts. An insert design was needed that was both reliable and allowed for easy assembly. The first design involved looping copper wire through holes in the SLA insert, shown in Figure 5-9. The wire coil served as a soft contact and was simple for connection to



Figure 5-9: Wire Contact for Dart Insert

the dart circuit. The second design involved looping  $.1$  in width x  $.75$  in length copper shim stock through slots in the SLA insert. The copper also served as a soft contact, but required additional soldering for circuit connection. In testing both designs, the team found that the wire was very difficult to loop through the small holes in the insert. The copper shims, however, were relatively easy to assemble into the insert if curled into a coil shape, shown in Figure 5-10a, prior to insertion. The curl in the shim guided it through the narrow slots in the insert. After the shim stock was curled into the insert, it was soldered closed and to a wire. An assembled insert with shim stock contacts is shown in Figure 5-10b.

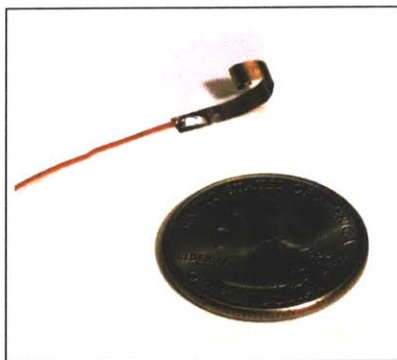

(a)



(b)

Figure 5-10: Shim Stock Contacts for Dart Insert



## Dart Redesign

The contact insert was applied to four different types of darts: Back Illuminating, Impact Illuminating, Front Illuminating, and Alternating Color Blinking. Their functions will be explained in the corresponding sections. In all dart redesigns, translucent white and yellow foam was used to allow for more light to transmit out the body of the dart. The following sections describe the prototyping of the four different types of eDarts used in the second iteration.

**Back Illuminating** The original concept, prototyped as a sketch model and in a first iteration, was a dart that illuminated out its back end. With this configuration, the user gets the full visual experience. To allow the LED to illuminate out the back of the dart, there could not be any obstructions within the dart. All components had to fit between the cap of the dart and the placement of the LED. The contact insert jack, however, needed to come before the LED to engage the blaster-side plug. The team made the contact insert tubular, as shown in Figure 5-11a, to allow the LED to snap fit into the front end of the insert and still transmit light out the rear of the dart. This orientation is shown in Figure 5-11b.

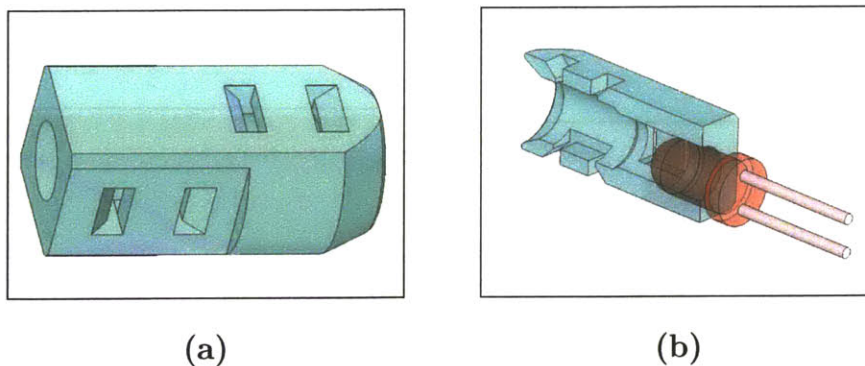

Figure 5-11: Contact Component for Back Illuminating Dart

The component layout was altered to allow the capacitor to fit entirely inside the dart body. The capacitor was rotated 90 degrees along its diameter. The resistors were placed beside each other between the capacitor and the transistor. This layout is shown in Figure 5-12a. Back illuminated darts are shown in Figure 5-12b.

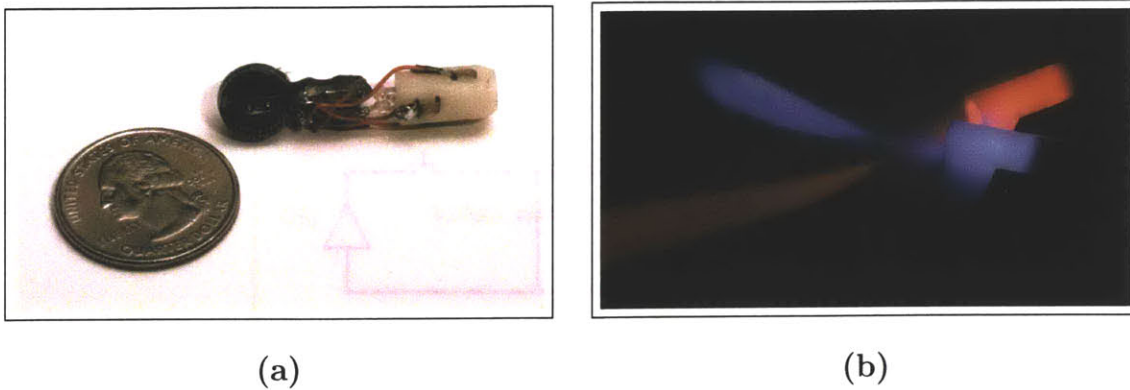

Figure 5-12: Final Back Illuminating Dart

**Impact Illuminating** Another dart design which the team felt worthy of prototyping was a dart that illuminated when the dart tip impacted a surface. The effect would be similar to a small light explosion on impact for play enhancement. The design required the dart to be back illuminated, as an impact switch was needed at the front of the dart. The tube-like contact insert was therefore implemented in the Impact Illuminating darts.

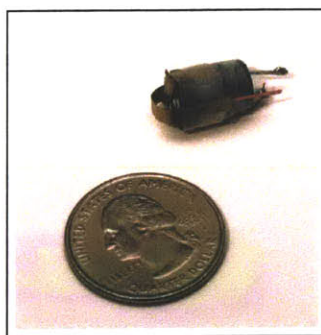

Figure 5-13: Shim Stock Switch for Impact Dart

To form an impact switch, two strips of copper shim stock were bowed around the front end of the dart and crossed, as shown in Figure 5-13. One shim was attached to the positive terminal and the other to the capacitor ground. Upon impact the two shim strips would touch for a small amount of time, thus completing the circuit to discharge the capacitor into the LED. The LED would then flash brightly for an instant.

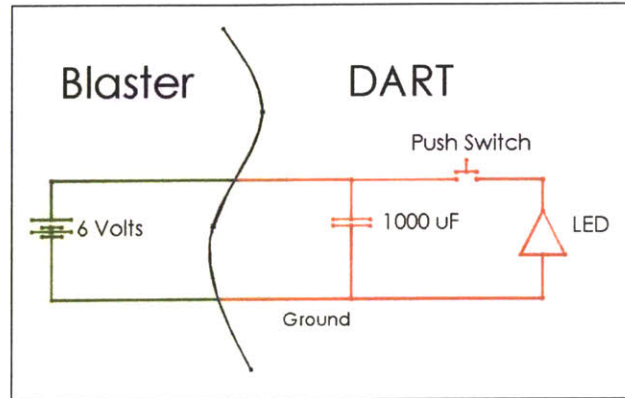

Figure 5-14: Impact Dart Circuit

As the LED was only required to be illuminated for a short amount of time, the team decided to use a smaller capacitor. The chosen was an electrolytic aluminum with a capacitance of  $1000 \mu F$ . This capacitor had a relatively low resistance allowing for a large amount of current discharge resulting in a brighter flash. No resistor was needed due to the short duration of flash. In addition, no transistor was needed as the shim stock acted as an impact switch. Without a transistor, only two contacts were required as shown in the circuit diagram of Figure 5-14. The Impact Illuminating eDarts had a much simpler circuit. The assembled impact dart components are shown in Figure 5-15.

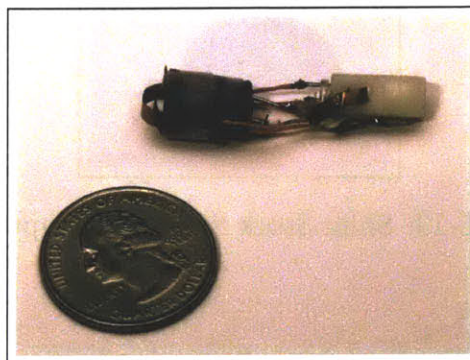

Figure 5-15: Final Impact Dart Insert

These darts were the least reliable of the four varieties, as the shim stock switch cracked after multiple uses. A redesign on the switch would be needed for a successful Impact Illuminating eDart.

**Front Illuminating and Alternating Color Blinking** The sponsor suggested, from a marketing point of view, that the eDarts illuminate out of the front end so onlookers may have the full visual experience. This design allowed for a less complicated layout. The LED no longer had to interfere with the contacts and was placed at the front of the dart. However, positioning the LED at the front of the dart required a special translucent resilient cap to allow light to pass through. For safety, the LED, as well as the other components, was inserted completely inside the body of the dart.

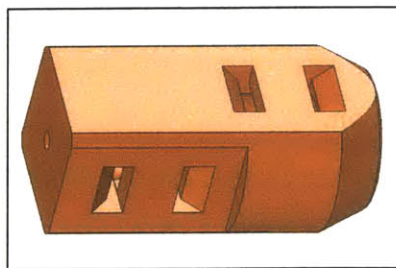

Figure 5-16: Contact Component for Front Illuminating Dart

A different contact insert was created for the Front Illuminating darts, as shown in Figure 5-16. This jack was not required to be tubular as the LED light did not have to pass through it. The jack was similar to those used in the Back Illuminating darts, but the end closest to the front of the dart was closed to allow for the mounting of the other components. The component layout is shown in Figure 5-17a. Front Illuminating darts are shown in Figure 5-17b. The Front Illuminating darts appear less bright than the Back Illuminating darts as the light is focused mainly into the cap.

The team wanted to experiment with the concept sampling to create the effect of slow flying darts (Matrix Darts) or darts frozen in mid-air. Recreating this effect would involve strobe firing of darts, or in this prototype, having darts that blink. If the darts blink at the same rate of rapid fire, the darts will only be seen at exactly the same position in the air and will appear stationary. As far as sampling terminology, this phenomenon corresponds to zero aliasing frequency [6]. If the darts blink somewhat faster or slower, they will appear to be moving very slowly through the air either

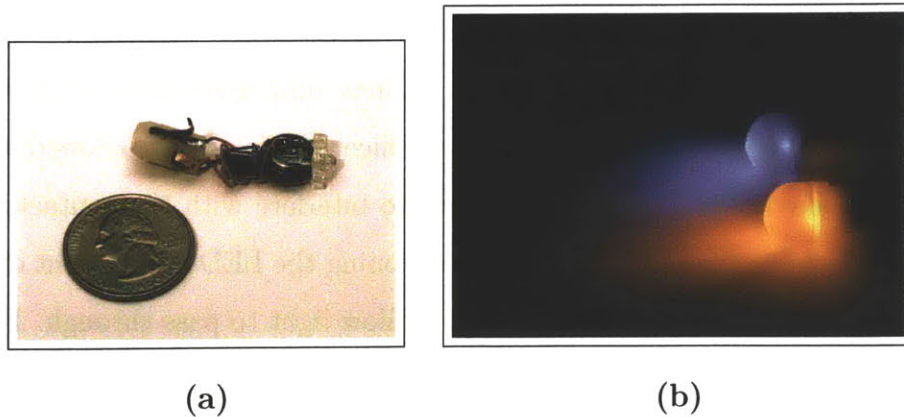

Figure 5-17: Final Front Illuminating Dart

forward or backward in direction.

In prototyping this concept, the team used the Front Illuminating orientation. An Alternating Color Blinking LED was found that would fit inside the body of the dart. Alternating color LEDs were used as they are capable of a high blinking frequency able to match that of the rapid fire. The component layout is shown in Figure 5-18. Future work on this concept would involve implementing an RC timer circuit to match the firing frequency.

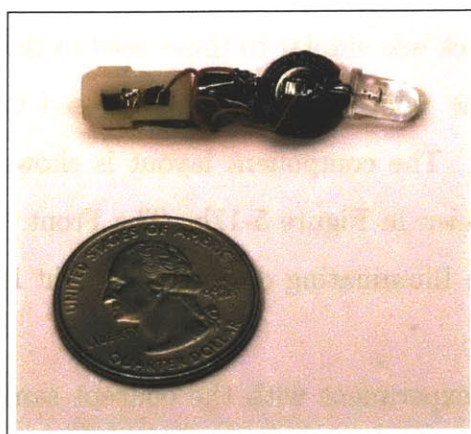

Figure 5-18: Contact Component for Alternating Color Blinking Dart

At first, in all dart designs, the dart components were press-fit into a straw segment to allow for easy insertion into the dart body. The team decided that shrink fit tubing, although slightly heavier, was better suited for these iterations. Having

the components held fixed with the shrink tubing, as shown in Figure 5-19a (Back Illuminated), allowed for easier insertion, as well as secured all components and their solder joints. The shrink fit components are shown in the body of the dart in Figure 5-19b.

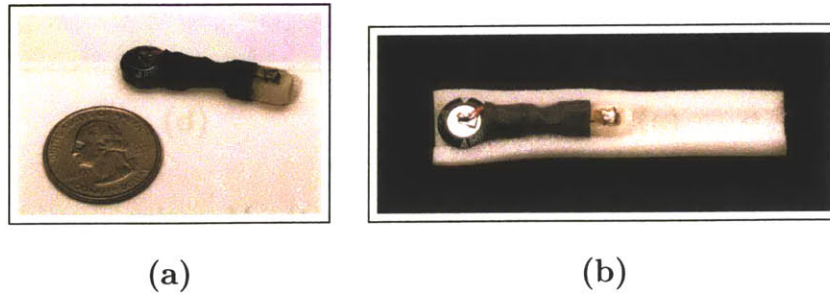

Figure 5-19: Securing the Electronics Inside the Dart Body

A round of each variety of eDart was prototyped, and the sponsor showed interest in all of them.

### Clip Redesign

The team decided to SLS prototype the entire magazine of the PowerClip™ to allow for wire channeling, internal electrical housing, and a new post design. In the first iteration, the exposed wires running from the barrels to the battery housing occasionally interfered with the firing as well as posed a safety hazard. Wire guides, as shown in Figure 5-20a, were modeled into the magazine to keep the wires safely enclosed. The top of the magazine (the battery compartment), as shown in Figure 5-20b, was redesigned to electrically and mechanically secure the battery and switch button.

The current posts in the Nerf® PowerClip™ are 2.3 *in*. The team adjusted the blaster post height to allow for proper alignment between dart jack and post plug. As shown in Figure 5-21a, the posts were shortened .95 *in*, and with the male plug insert, the posts became 1.5 *in*. The post height is crucial, as the sponsor requires a 1.57 *in* post to prevent the firing of foreign objects. The posts were designed for the 1/8 *in* stereo jack to snap fit inside. The post was hollow to allow the wires to pass inside and then along channels in the rear. An assembled post is shown in

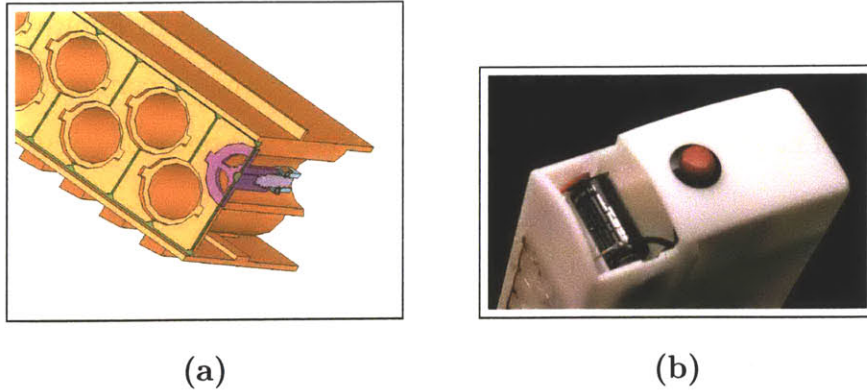

Figure 5-20: Modifications to the Magazine

Figure 5-21b. The assembled magazine is shown in Figure 5-22. The PowerClip™ magazine advancement mechanism was very sensitive, so the screws holding the outer housing around the PowerClip™ had to be finely adjusted when incorporating the SLA prototyped magazine.

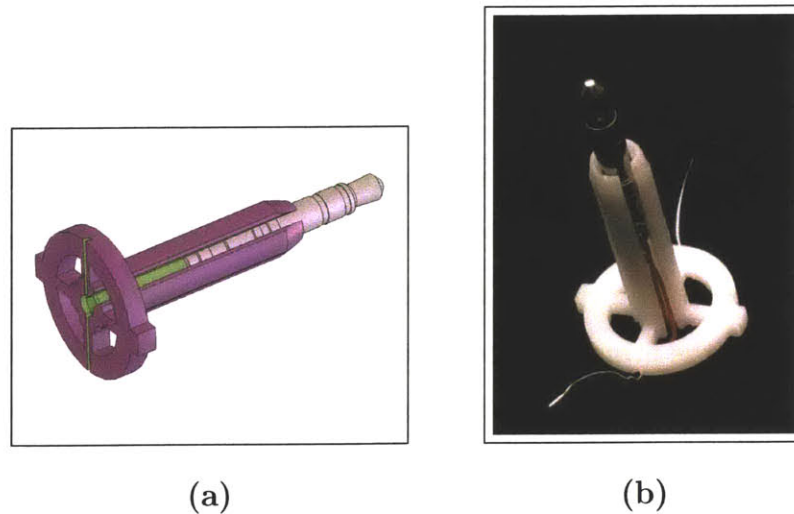

Figure 5-21: Redesigned Blaster Post

This iteration was successful and all varieties of darts worked well in the redesigned magazine. The sponsor felt this iteration was ready for manufacturing preparation and continued to develop the product in-house. There was, however, a problem with these second iteration darts involving shorting the capacitors. If one or several darts are not inserted completely into their barrels, the dart contacts bridge the blaster-

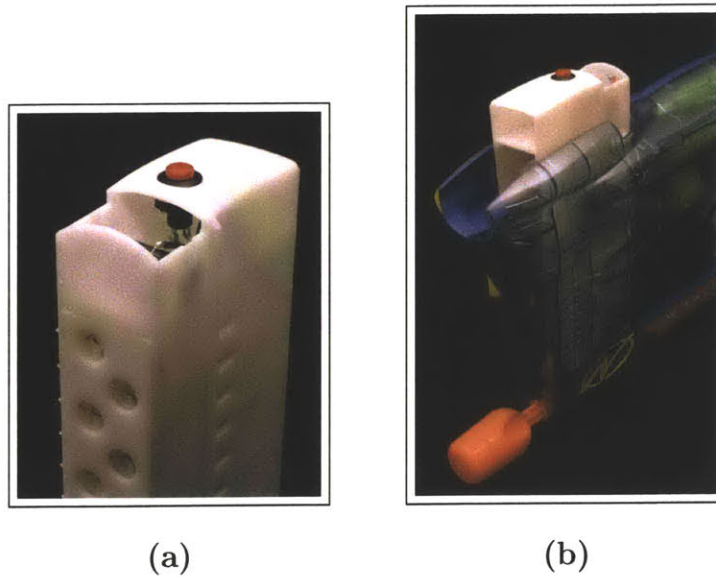

Figure 5-22: 2nd Iteration Blaster

side positive and ground terminals as shown in Figure 5-23. This results in the discharging of all eDart capacitors as the capacitors are charged in parallel. This happens briefly every time a dart is inserted or fired. The team was aware of this problem when designing the contacts, but it was assumed acceptable for an easily constructed second iteration.

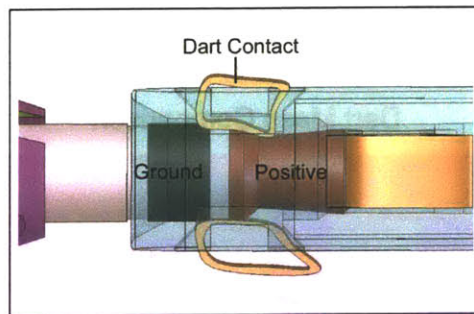

Figure 5-23: Dart Contact Bridging Blaster Contacts

To avoid the shortage problem, the contact orientation shown in Figure 5-24a can be implemented. This layout, similar to a DC power connection of Figure 5-24b, eliminates the possibility of shorting the circuit. In this configuration, the blaster plug is a tube having the positive contact on the inner surface and the ground contact on the outer surface. On the dart jack, a pin acts as the positive contact to engage the



inner plug surface. The ground and gate contacts on the dart jack are soft flexures which touch the common outer surface of the blaster plug.

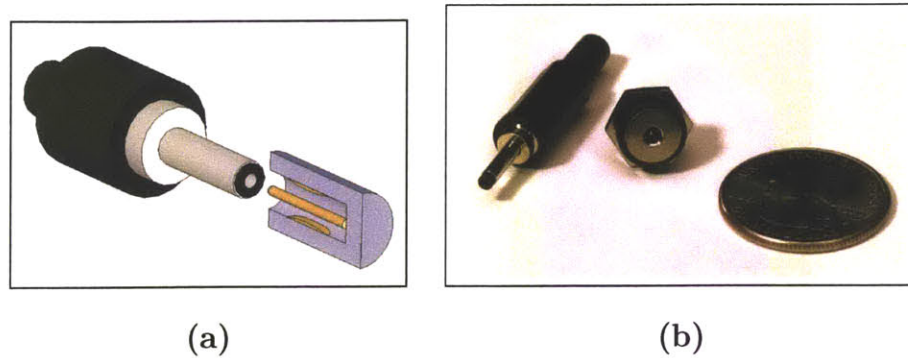

Figure 5-24: DC Power Connection

## 5.2 Refining the Concept

This section describes the analysis of the eDarts, provides suggestions for improvement for a final iteration, and makes a comparison to the state of the art.

### 5.2.1 eDart Analysis

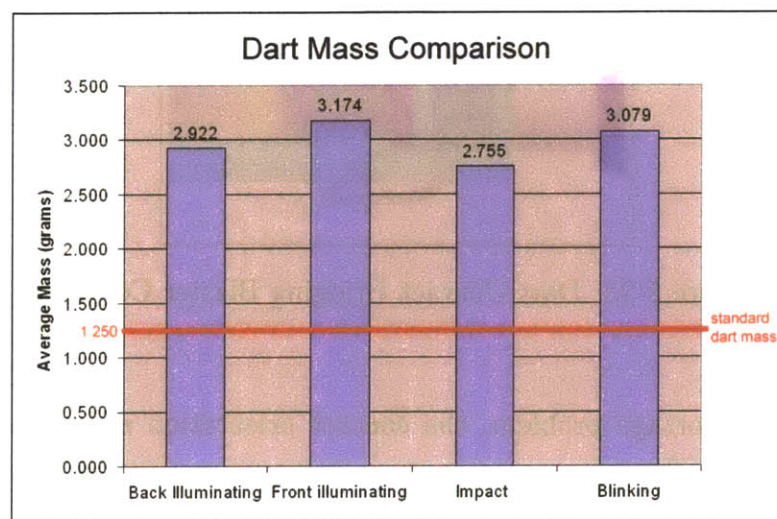

Figure 5-25: 2nd Iteration Dart Mass Comparison

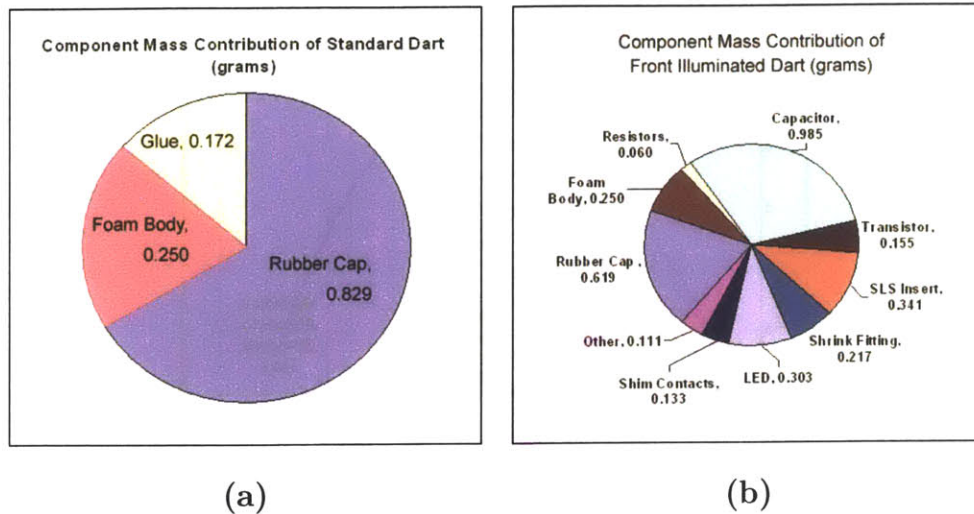

Figure 5-26: Dart Component Mass Contribution

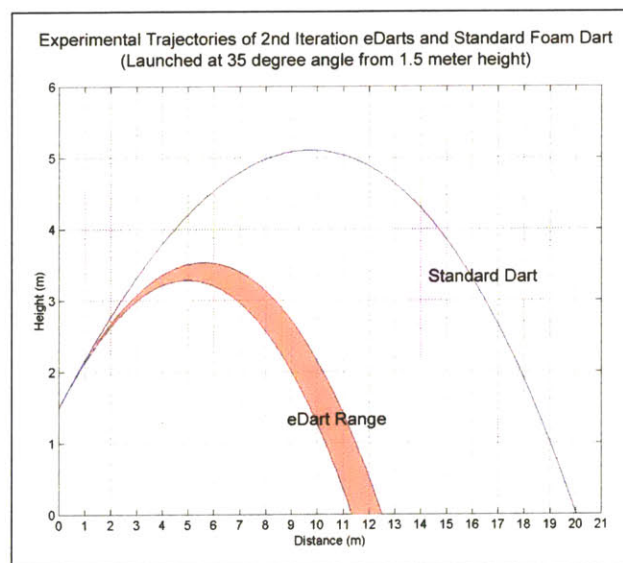

Figure 5-27: Trajectories of Standard Dart and 2nd Iteration Darts

Analysis was required to determine if the eDarts met the sponsor’s safety requirements. The Kinetic Energy Density was the critical safety issue, as the mass of the eDarts is much greater than that of the standard foam darts. The team first determined the mass of the eDarts and the contribution of each component.

Figure 5-25 shows the average masses of the different eDarts compared to the mass of the standard foam dart of equal size. As shown, a standard foam dart has approximately 58% less mass than the average eDart.

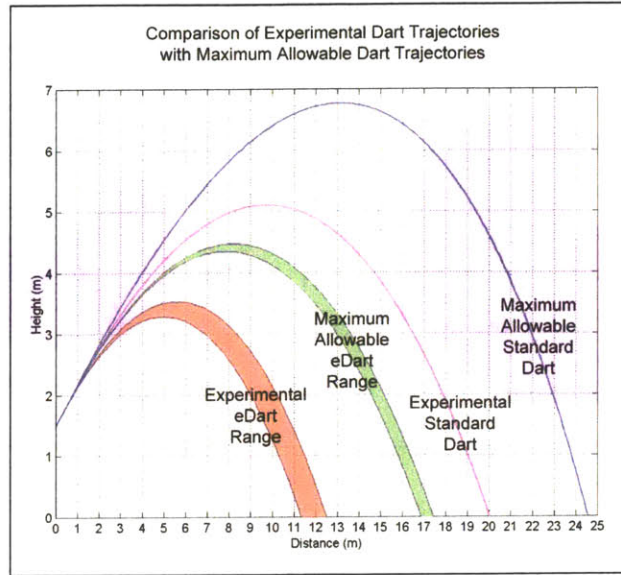

Figure 5-28: Maximum Allowable Trajectories of Standard Dart and 2nd Iteration eDarts

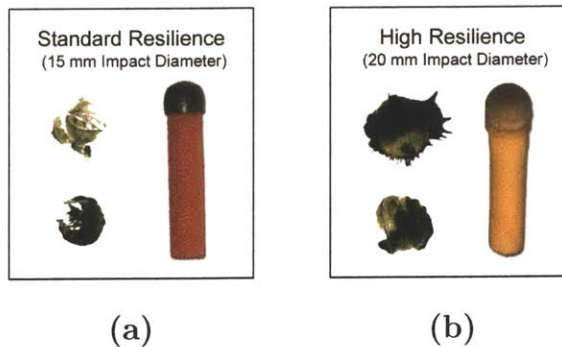

Figure 5-29: Standard and High Resilience Dart Impact Markings

The mass contribution of the components in the standard foam dart is shown in Figure 5-26a. The mass of the standard dart being 1.250 g is approximately the optimal mass for its given size and impact area. The weight of the glue holding the cap to the body is in excess to raise the overall mass to this optimum.

As shown in Figure 5-26b, the largest percentage of eDart mass (represented by the Front Illuminating eDarts) was the capacitor, followed by the rubber resilient cap and the SLS insert. The LED, the foam body, and the shrink fitting also contribute a significant amount of mass. The “other” category was calculated by subtracting the total eDart mass from the combined mass of the individual components. In the case

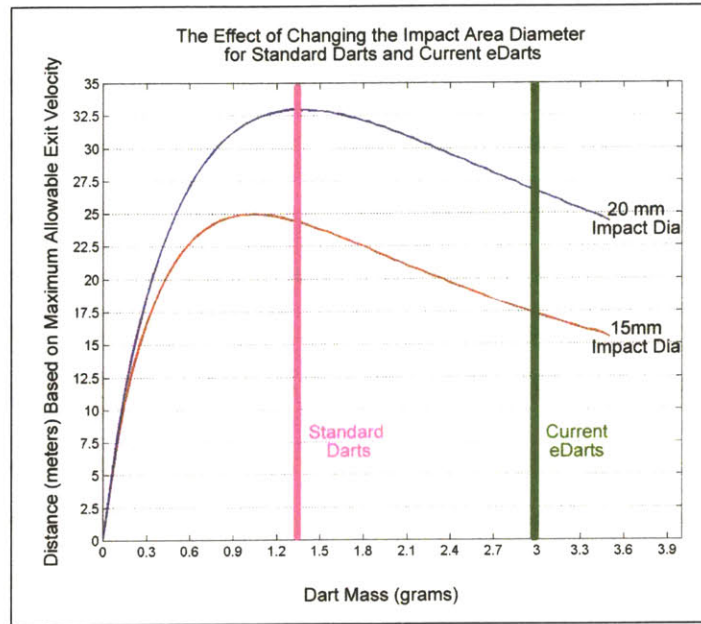

Figure 5-30: Effect of Changing the Impact Area for Standard Dart and 2nd Iteration Darts

of the eDarts, this category represents the solder and extra wire.

The team then tested these second iteration eDarts as well as standard foam darts for maximum horizontal distance using the Nerf® PowerClip™. The PowerClip™ was angled at 35 degrees from the horizontal and elevated 1.5 m off the ground. The heaviest (Front eDarts) and the lightest (Impact eDarts) were tested. Figure 5-27 compares the range of horizontal distances achieved by the eDarts to that of the standard foam dart of equal size. The graph shows that the average eDart traveled approximately 40% of the distance traveled by the standard foam dart. This difference was a result of its larger mass and possible increased drag from off-centered mass. If the mass is off center, fishtailing occurs and the drag on the dart drastically increases. The team then needed to determine if the eDarts remained under the required Kinetic Energy Density limit.

Amanda Bligh, a Hasbro® engineer, provided a MATLAB program which determined the dart distance based on maximum allowable exit velocity with an input of dart mass, a given standard impact diameter (taken from the projected area of surface contact), and a given Kinetic Energy Density limit of 1600 J/m<sup>2</sup>. The code

accounts for drag and assumes the darts are fired at a 35 degree angle from a height of 1.5 *m*. Figure 5-28 shows the maximum allowable trajectory of the different eDart varieties and the standard dart compared to the experimental trajectories.

The distance achieved by both the eDarts and the standard darts was 5 *m* less than their allowable distances. As the current eDart iteration (and even the standard darts) is far under the allowable distance (i.e. Kinetic Energy Density), the team decided that the eDarts and the PowerClip™ could benefit from optimization.

The maximum allowable distance is dependant on the maximum exit velocity. This maximum allowable distance can be further increased by increasing the impact diameter and by decreasing the mass of the dart. This is shown in the Kinetic Energy Density equation (5.1) with rearranged variables; where *v* is the initial dart velocity, *KE* is the kinetic energy, *m* is the dart mass, and *d* is the impact diameter.

$$v = \sqrt{\frac{8 \cdot KE}{\pi \cdot m \cdot d^2}} \quad (5.1)$$

The impact diameter can be increased by implementing a larger resilient cap as shown in Figures 5-29 or by using larger darts (the latter, however, will also increase the mass). The larger cap increased the impact diameter by 5 *mm*.

A MATLAB program was created which plots distance based on maximum allowable exit velocity as a function of dart mass with a given impact area. Figure 5-30 shows the current eDarts and standard darts on the mass vs. maximum distance plot.

With the larger more compliant dart cap, the darts are allowed a larger distance for the same dart mass. With the standard dart cap, the optimal mass is at 1.1 *g* where the dart is allowed to travel 25 *m*. Using the more resilient dart cap, it can be seen that the optimal dart mass is 1.3 *g*, and the dart can travel 33 *m*.

Note that the standard darts are close to the optimal mass for maximum allowable distance. The current eDarts are much heavier and further from the optimal mass; therefore, they have a lower allowable distance. The next section describes the optimization of the design.

## 5.2.2 Final Design Suggestions

The sponsor felt that the second iteration eDarts design was suitable for overseas in-house engineers to use in finalizing the product; however, the team felt further improvement was possible. In this section the team makes suggestions for further improving the circuit and contacts to reduce the eDart mass. The team also suggests a means of improving the blaster to achieve the allowable eDart distance.

### eDarts

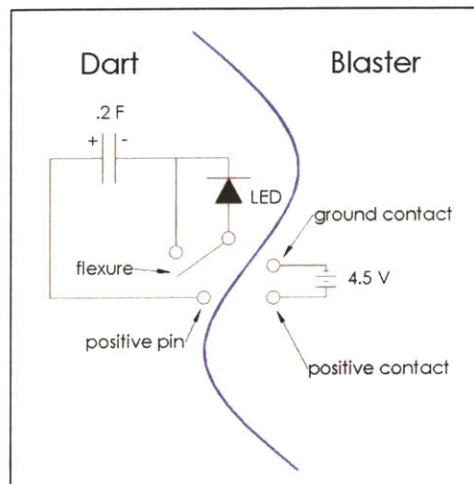

Figure 5-31: Final Circuit Design

The team desired to reduce the dart mass as much as possible without sacrificing the LED brightness. The team began by evaluating the heaviest component, the capacitor. Lighter and smaller capacitors are available with 10x the capacitance of the capacitors of the second iteration. These capacitors are only available in 3.3 V, so to illuminate the blue, green, and white LEDs, two of these small capacitors would be needed in series. The team tested the current circuit with these alternative capacitors and found that their internal resistance was too high to provide the required current to illuminate any color LED. Bypassing the transistor, with the LED directly connected to the capacitor, the LED illuminated to previous standards. The team found that the transistor and the two resistors can be replaced by a mechanical switch. To avoid

implementing an additional component, the team incorporated the mechanical switch into the contact. Without the transistor, only two contacts are needed in the dart. This much simpler circuit is shown in Figure 5-31.

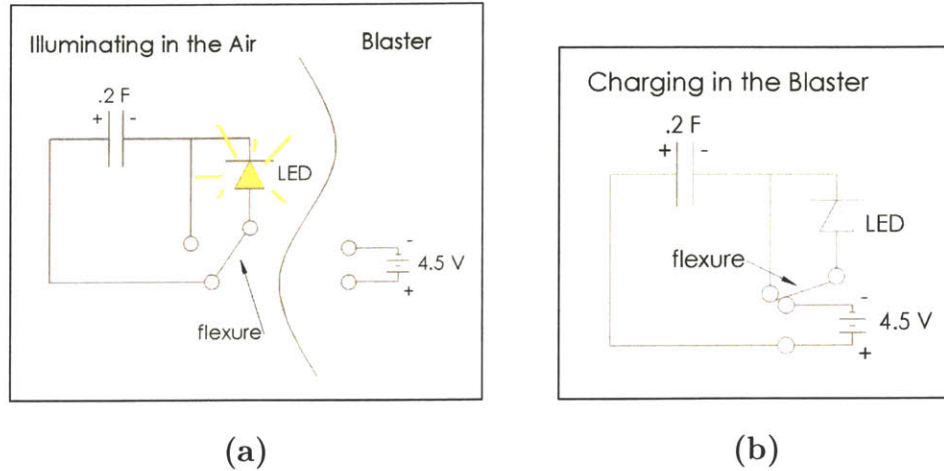

Figure 5-32: Final Circuit

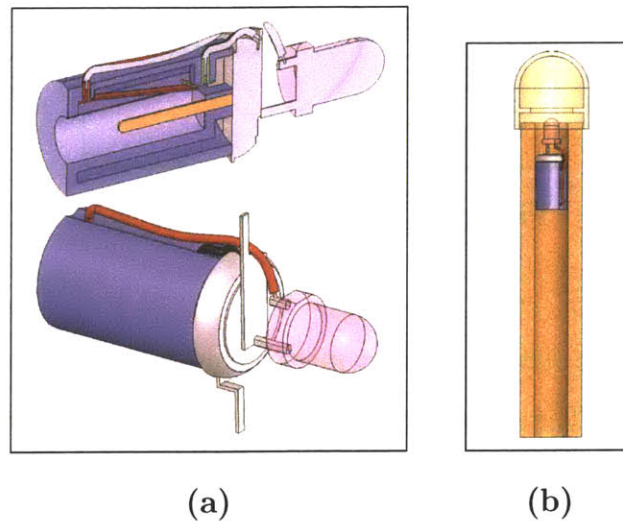

Figure 5-33: The Final eDart

As shown in the Figure 5-32a, when the eDart is not in the blaster, the capacitor discharges through the LED. The team used the standard  $.7 \text{ mm}$  ID/ $2.35 \text{ mm}$  OD DC power plug, as suggested in the second iteration in the blaster. When the eDart is inserted into the barrel, the flexure connecting the LED and capacitor moves aside

and breaks the circuit. The LED is then disconnected from the circuit and the positive contact on the post charges the capacitor. This is shown in Figure 5-32b.

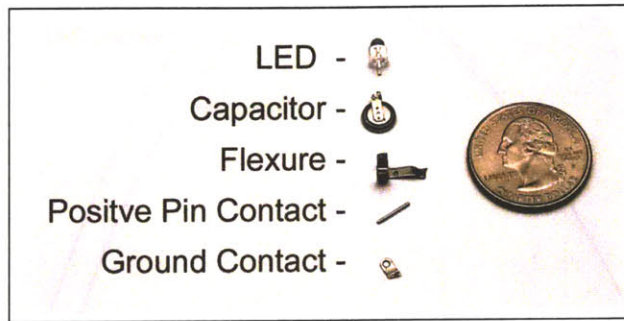

Figure 5-34: Final eDart Components

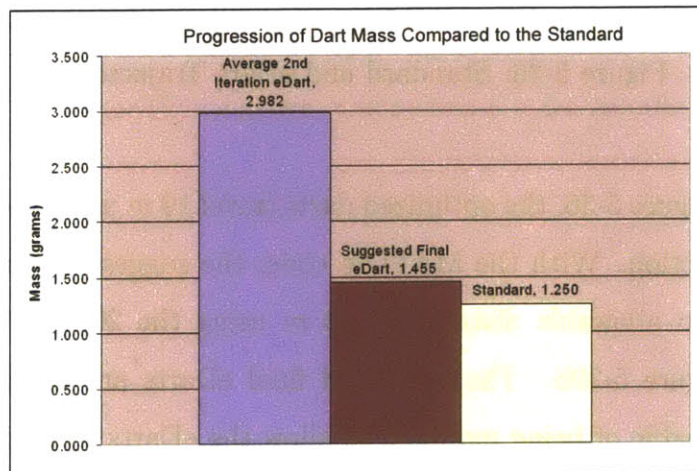

Figure 5-35: Dart Mass Comparison

With this simplified circuit, the mass of the eDart was significantly reduced. The number of dart circuit components then included a small capacitor, a small LED, a flexure, two contacts, and housing. These components, aside from the housing, are shown in Figure 5-34. A CAD model of an assembled front illuminating eDart is shown in Figure 5-33. The team generated a mass of the housing by assigning polypropylene density to the CAD model. The total mass of this redesigned eDart was approximately 1.455 g which is 50% less than the current eDart iterations and just 16% more than the standard dart. This is shown in Figure 5-35. The length of the insert was also reduced from 40.5 mm to 17 mm.



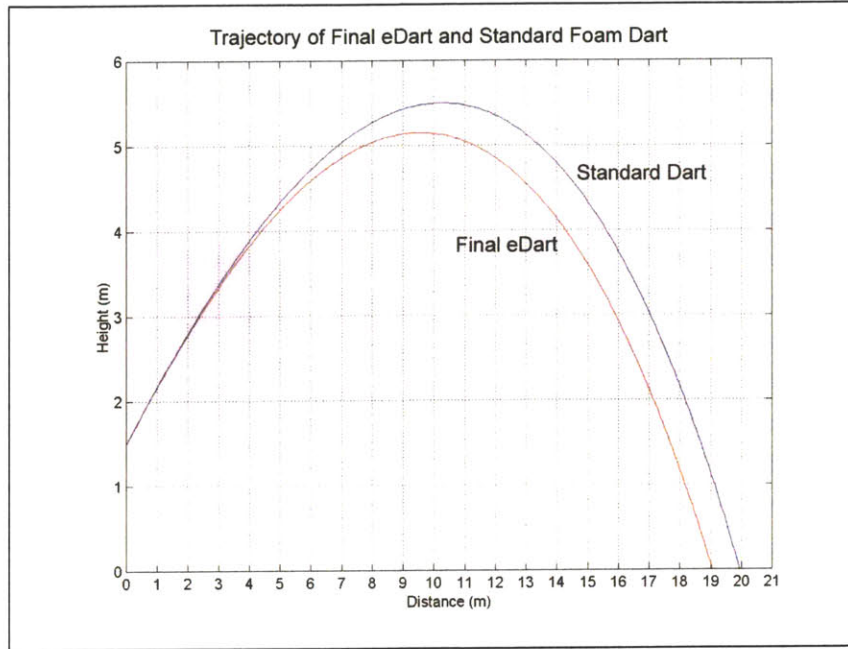

Figure 5-36: Standard and eDart Trajectories

As shown in Figure 5-36, the optimized darts travel 19 *m* using the testing scenario in the analysis section. With the MATLAB code, the suggested final eDart of 1.455 *g* has a maximum allowable distance of 33 *m* using the 20 *mm* impact diameter tip, shown in Figure 5-29b. The suggested final eDarts are at the optimal mass. The blaster is capable of being modified to allow the eDarts to reach this maximum allowable distance (reaching max KED). This is explained in the following section.

## Blaster

Both the PowerClip™ Magazine and Pressure system can be optimized for this suggested eDart redesign. With the new 3.3 *V* capacitor, three AA 1.5 *V* batteries are suggested. Two batteries can be used, but the time to charge the capacitors becomes slightly longer and the LEDs cannot reach their maximum luminescence. The magazine battery housing must be redesigned to fit these standard size batteries.

The redesigned eDarts have fewer and smaller components. These components can be condensed into a very small region at the head of the eDart body. This allows for more room in the inside of the dart body; therefore the blaster posts can be longer.

In the second iteration the blaster posts were just under the allowable safety length. In this suggested redesign, the posts can be well over the minimum allowable length.

The improved eDarts travel 19 *m* with the current PowerClip™ blaster, but are allowed to go up to 33 *m* to remain under the 1600  $J/m^2$  KED given the use of the 20 *mm* impact diameter. There are several possible means of increasing the blaster pressure to reach this allowable distance. The bladder stiffness can be increased to allow for a higher constant pressure. This method, however, would require a modification in the timing, as the pressure governs the speed of the magazine advancement.

Another means of increasing the pressure requires altering the pressure release mechanism shown in Figure 5-37. This mechanism is the heart of the PowerClip™; it is responsible for advancing the magazine and releasing equal blasts of air in a timed manner. Air enters the mechanism chamber and compresses the large spring which pushes the mechanism forward and the wedge advances the magazine. In moving forward, the mechanism stretches the smaller spring. At a certain distance, determined by the smaller spring constant, the force of the smaller spring overcomes the pressure and the yellow stopper releases the air in the chamber.

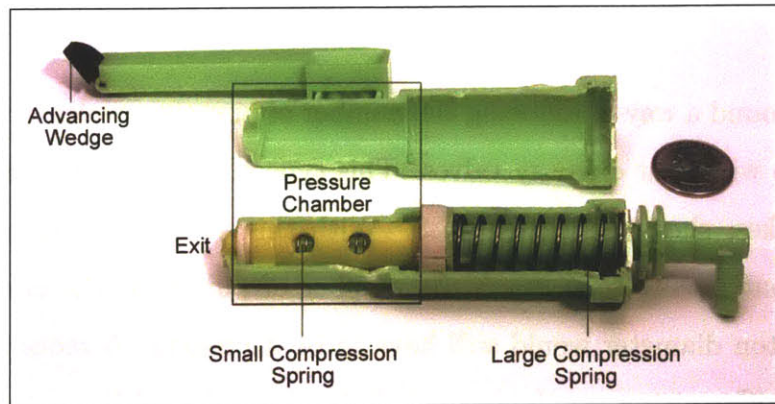

Figure 5-37: PowerClip™ Pressure Release Mechanism

In order to use more pressure for each blast of air without having the mechanism travel a greater distance, one can either increase the stiffness of both spring constants equally or decrease the piston areas equally. Decreasing the area, however, reduces the volume and thus the amount of air used to propel the dart. Increasing the stiffness of

the springs would be a better means of transmitting higher pressure air to the darts. Altering the mechanism would slow the rate of fire.

The optimal means of increasing the amount of pressure while maintaining the current firing rate would require stiffening both the bladder and the two springs. All these methods would require either more pumping at the current pumping force (18 lbs) or a greater pumping force at the same number of pumps (12-13). The former would require a smaller pumping piston diameter. These methods are not acceptable solutions as they are inconvenient for the user.

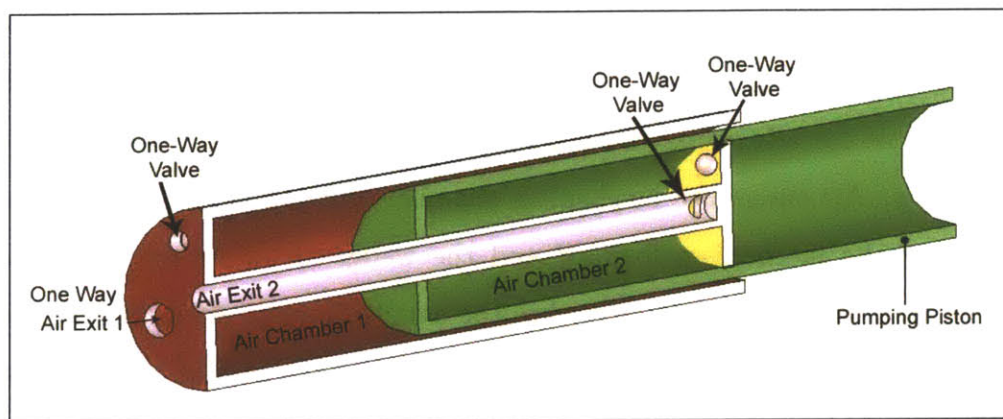

Figure 5-38: Piston Pump with Four One-Way Valves

The team found a way of reducing the number of pumping cycles by implementing a piston pump with four one-way valves. This type of pump expels air on both pull and push strokes, shown in Figure 5-38. With this pump, the stiffer bladder can be filled without having to increase the number of pumps or the current pumping force. The piston diameter would still have to be decreased. A redesign should also implement a stiffer piston, as the current design is weak and flexes easily. A hollow tube should be used as it has a greater bending stiffness.

## Safety

The suggested final eDart design is well under the allowable KED limit using the unmodified blaster. The blaster can be altered as described in the previous section to increase the eDart distance to the maximum allowable. The final design allows

for proper length safety posts in the barrels to prevent the firing of random objects. The greatest issue of concern regarding the eDarts is the small electrical components embedded within the dart. These have to be manufactured to ensure that they remain within the dart for the lifetime of the product.

### Comparison to State of the Art

The greatest differences between the standard darts and the eDarts, aside from cost, are the masses and distances. The standard dart has a mass of 1.25 g while the eDart has a mass of 1.455 g. Figure 5-39 compares the mass contributions of the standard dart to that of the suggested final eDart. Using the unaltered PowerClip™ set at a 35 degree angle, 1.5 m off the ground, the standard darts traveled a distance of 20 m and the suggested final eDarts traveled a distance of 19 m. This is shown in Figure 5-36. Implementing the cap with a 20 mm impact diameter, both the standard darts and suggested final eDarts are allowed a maximum distance of 33 m. This is shown in Figure 5-40. The suggested final eDarts are at their optimal mass.

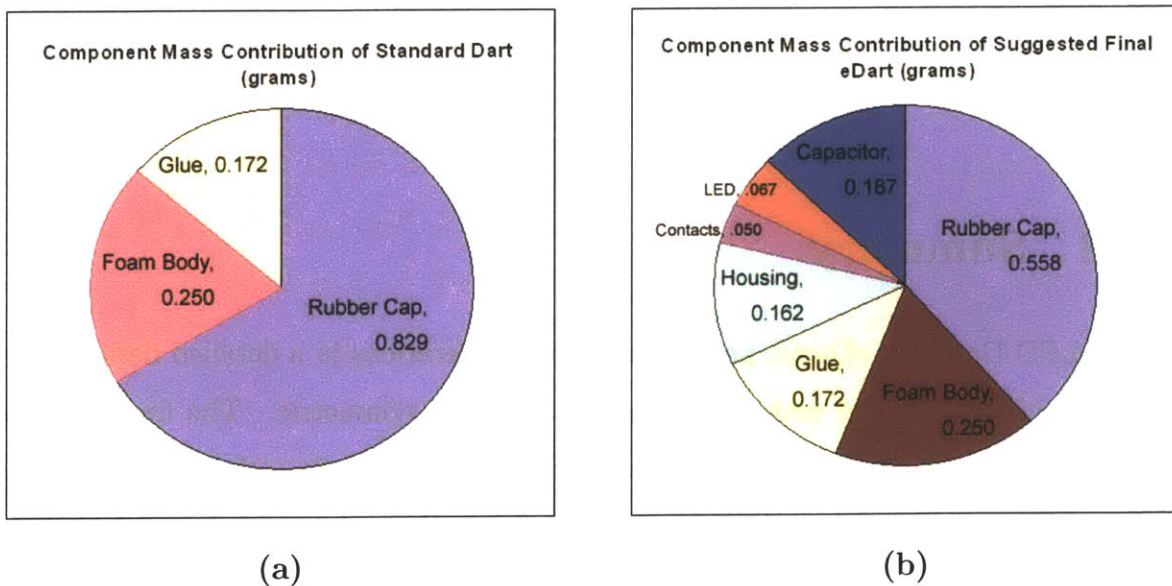

Figure 5-39: Comparison of Dart Component Mass Contribution

Although not required, the blaster can be optimized to have the eDarts reach their maximum allowable distance. This can be achieved with the same amount of pumps

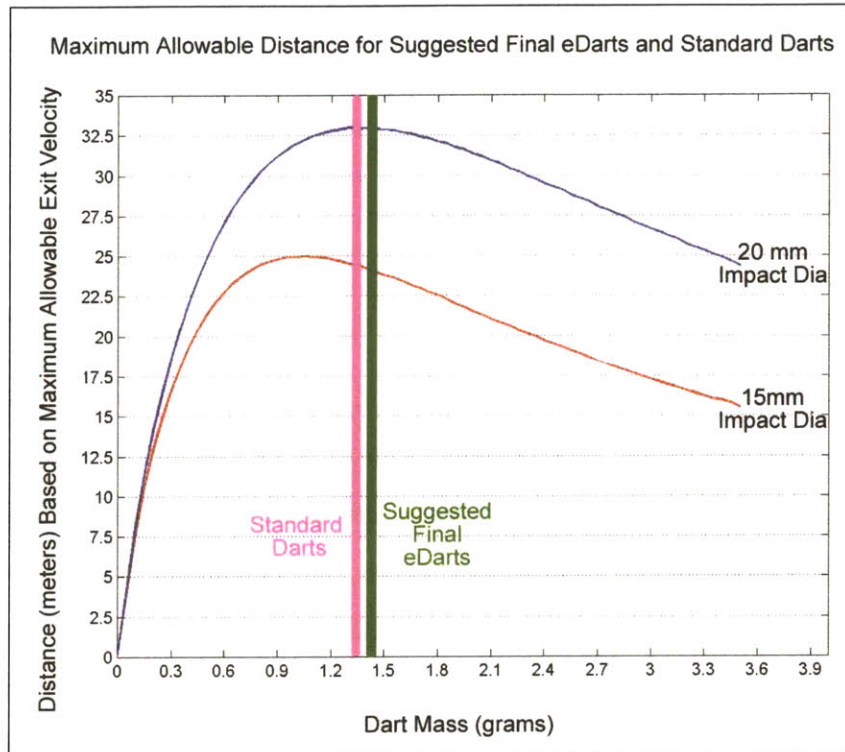

Figure 5-40: Maximum Allowable Distances of Final eDart and Standard Dart

as the unaltered blaster when implementing a pump that expels air on both pull and push strokes.

### 5.3 Summary

The LED Darts (or eDarts) passed through two iterations in a detailed design phase both with the goal of making the contacts axially symmetric. The first iteration involved using conductive paint as a means of creating simple and safe external contacts. This design was crude and unsuccessful as the paint tended to flake off the foam body. The second iteration involved incorporating a 1/8 in stereo plug into the blaster posts and a custom SLS contact jack into the dart. This concept was applied to four different varieties of eDarts: Front Illuminating, Impact Illuminated, Back Illuminating, and Alternating Color Blinking. This design was more robust and efficient, but very heavy compared to the standard foam dart. A final iteration

was developed incorporating a standard DC connection. The circuit was simplified by replacing the transistor and two resistors with a mechanical switch. Without the transistor, a smaller capacitor was able to be used. The suggested final eDart mass was reduced to 1.455 *g* which is slightly greater than the mass of the standard foam dart being 1.25 *g*. Fired from an unaltered PowerClip™ at a 35 degree angle 1.5 *m* off the ground, the suggested final eDarts traveled a distance of 19 *m*, which is only 1 *m* less than the standard foam darts. With a 20 *mm* impact diameter resilient cap, these eDarts were allowed to go 33 *m* to remain under the Kinetic Energy Density limit. The PowerClip™ can be modified, if desired, to reach this maximum distance by stiffening the compression springs and bladder in the pumping system. A new pump piston was suggested to reduce the number of required pumps. The sponsor was very pleased with the concept and iterations and continued to develop the eDarts in-house for manufacture with these final suggestions.



# Chapter 6

## Conclusion

### 6.1 Summary

The team reduced an initial group of over 100 concepts to 30 high potential concepts. The following six high potential concepts were prototyped with a sketch model: String Shooter, Rocket Darts, Mist Blaster, Water Blobs, Foam Grenade, and LED Darts. The Foam Grenade concept evolved into a more general concept of Hopper Popper Activation which involved a bi-stable rubber spring capable of projecting foam balls. Both Hopper Popper Activation and LED Darts, being the most promising, advanced to a detailed design stage.

#### 6.1.1 Hopper Popper Activation (Hand Popper)

In the Detailed Design phase, the Hopper Popper Application was applied to two iterations of a Hand Popper, a small hand-held toy capable of launching foam balls, as well as two versions of a Foam Grenade. The sponsor showed a greater interest in the Hand Popper over the Foam Grenade. The greatest issue of concern was the force required to load the popper. After testing several means of lowering the loading force, a low friction design was chosen for the final iteration of the Hand Popper. This final iteration, shown in Figure 6-1, required an average of 18.5 *lbs* of force to load, which was less than the operating force on firing the Nerf<sup>®</sup> Ball Blaster<sup>™</sup>. The final



iteration was also capable of projecting a foam ball 20% further than the state of the art.

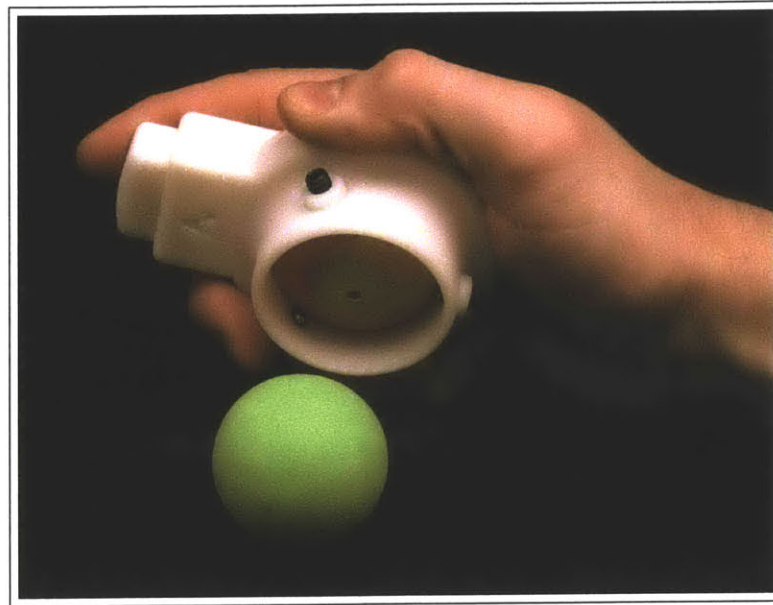

Figure 6-1: Final Hand Popper Iteration

### 6.1.2 LED Darts (eDarts)

In the Detailed Design phase, the LED Dart concept evolved through two iterations, both in attempt to provide for axially symmetric loading. The first iteration involving conductive film/paint contacts did not meet expectations. The second iteration using a 1/8 in stereo plug on the blaster post and a customized jack in the eDart body was highly successful. Four versions of eDarts were developed: Back Illuminating, Impact Illuminating, Front illuminating, and Alternating Color Blinking. The mass of the eDart was the greatest issue of concern with this second iteration.

The final design, shown in Figure 6-2, implemented a simple mechanical switch, which allowed for fewer and lighter dart circuit components. The mass of this final eDart was reduced to approximately 1.45 g. This is slightly greater than the mass of a standard foam dart being 1.25 g. The final design was capable of traveling 19 m when fired at 35 degrees from a PowerClip™ elevated 1.5 m off the ground. Implementing a resilient cap with an impact diameter of 20 mm, the eDart is allowed to travel up

to 33 *m* to remain under the Kinetic Energy Density limit. Although not required, the blaster can be modified to allow the eDarts to reach this limit.

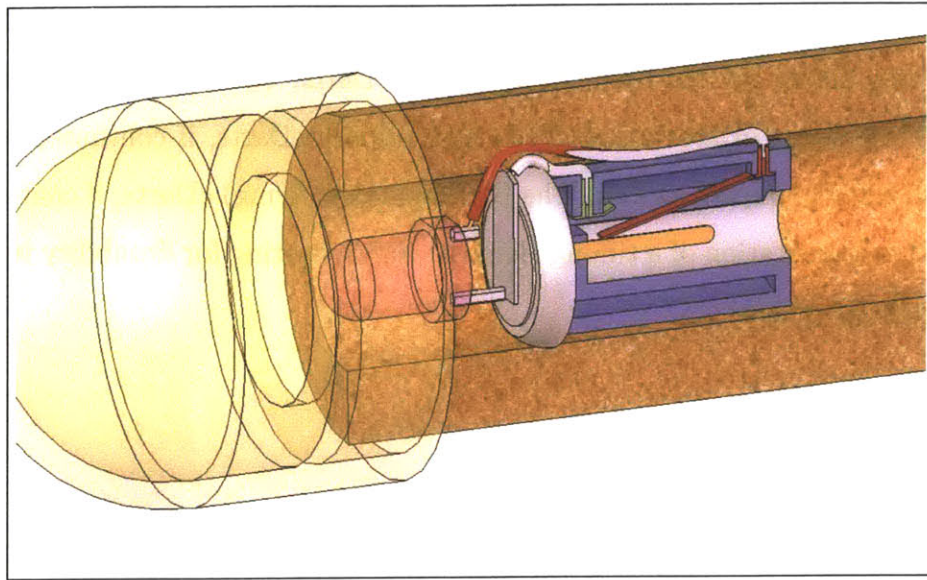

Figure 6-2: Final eDart Cross Section

## 6.2 Future Work

### 6.2.1 Hopper Popper Activation (Hand Popper)

This research focused mainly on implementing the hopper popper into a small hand-held device. Future work can include refining the grenade applications of the hopper popper as well as the blaster and shotgun applications. The Hand Popper requires further refinement regarding manufacturing and a better means of reducing the loading force. Using the dry lubricant was sufficient for a final prototype, but the team suggests other means of reducing the loading force such as bearings, elastic constraint, a lever-arm skirting, or a redesigned softer hopper popper.

### 6.2.2 LED Darts (eDarts)

The eDarts are currently in the process of being analyzed in-house for manufacturing. Future work is needed in prototyping the mechanical switch circuit in the suggested

final design and constructing a lightweight housing for the internal dart components. Currently, the suggested final circuit requires an extra capacitor and battery to illuminate high frequency LEDs; the circuit is acceptable for all other colors. This final design is well suited for the Front Illuminating eDarts, but further design is needed if Back Illuminating eDarts are desired. The Impact eDarts, if continued, require a redesigned reliable impact switch. The Blinking (slow flying) eDarts, if continued, require the implementation of a timing element. Safety testing for durability is required on the finalized design.

# Appendix A

## Text Documents

# A.1 Hasbro Inc Corporate Quality Assurance Safety and Reliability Specification

**HASBRO INC.**

**CORPORATE QUALITY ASSURANCE  
SAFETY AND RELIABILITY SPECIFICATION**

**SRS - 045  
TITLE: PROJECTILES**

**BY: C. FISCHER  
DATE: JUNE 16, 1999**

**APPROVAL:  
REVISION: G**

## **1.0. PURPOSE**

To establish specifications for the various structural characteristics and kinetic parameters of projectiles used on Hasbro, Inc. products. The intent of these specifications is to minimize any potential for injury (especially eye injury) to children while simultaneously maintaining the traditional play value represented by projectiles at an acceptable, but under reasonably foreseeable conditions of use and abuse, safe level. Conformance to the requirements of this specification will also ensure compliance to global requirements for projectiles.

## **2.0. SCOPE**

This specification applies to both toys A) that are intended to launch projectiles into free flight by means of a discharge mechanism in which the kinetic energy of the projectile is determined by the toy and not by the user and B) certain projectile toys without stored energy. (i.e. arrows and darts intended to be thrown, helicopter rotors, propeller blades, bows and arrows and other items intended to be thrown, but not intended to be caught).

This specification does not apply to discharge mechanisms intended to propel a ground based vehicular toy along a track or other surface, nor when a projectile is inaccessible to a child when it leaves the discharge mechanism (e.g. a pin ball machine).

Projectiles without stored energy are acceptable only for toys with a minimum age grade of 3 years and up.

Projectiles are acceptable only for toys with a minimum age grade of 4 years and up)

Projectile guns and bows and arrows are acceptable only for toys with a minimum age grade of 5 years and up.

Helicopter-type projectiles that are intended for vertical discharges are only acceptable for toys with a minimum age grade of 6 years and up.

## **3.0 DEFINITIONS**

3.1 **PROJECTILE WITH STORED ENERGY:** an object propelled by means of a discharge mechanism capable of storing and releasing energy under the control of the operator.

- 3.2 **PROJECTILE WITHOUT STORED ENERGY:** An object propelled solely by the energy imparted by a child.
- 3.3 **DISCHARGE MECHANISM:** an inanimate system for releasing and propelling projectiles.
- 3.4 **PROJECTILE TIP** - Any portion of a projectile that can reasonably be expected to contact an impact surface (e.g. an eye) during flight. A tip end or leading edge of a projectile is not the only possible "tip". On disc or saucer like projectiles, the "edge" of the disc is considered as the tip. On rotor-type projectiles that have a ring around the perimeter, all exposed surfaces of the ring should be considered "tips".
- Note: The requirements of 6.3 apply to all "tips".
- See Figure 2 for a pictorial depiction of the proper radii on a disc-type projectile.
- 3.5 **PROTECTIVE TIP:** - a component that is attached to the impacting end of a projectile to minimize injury if it should impact on the body and also to prevent damage to the projectile on striking a target, or prevent damage to inanimate objects.
- 3.6 **RESILIENT TIP:** a tip on impact surface of a projectile that has a Shore A durometer not greater than 55 (as measured on the impact surface of the tip).
- 3.7 **RIGID PROJECTILES:** projectiles with an impact tip that has a shore A durometer that is greater than 55.
- 3.8 **PROJECTILE GUNS AND BOWS AND ARROWS:** are hand-held projectile launchers that are comparable in scale to a real firearm or bow and arrow. For purposes of this specification, small projectile launchers scaled to the size of toy figures (e.g. G.I. Joe) are not "projectile guns".

#### **4.0. TEST EQUIPMENT**

- 4.1 A radar gun capable of measuring a small projectile (larger than Hasbro small part gage) traveling at a high speed (e.g. 11 miles/hour).
- 4.2 Hasbro small parts cylinder (per SRS-001, figure 2).
- 4.3 Laboratory balance with an accuracy of +/- 0.1 gram. (i.e. Sauter K800).
- 4.4 Aluminum foil complying with the requirements of 5.2.
- 4.5 A steel ball having a nominal diameter of 15 mm and a mass of 14.00 +/- 0.05 grams.
- 4.6 Clamps to uniformly clamp the diaphragm in the supporting frame - See Figure 1.

## 5.0 TEST PROCEDURE

### 5.1 KINETIC ENERGY DETERMINATION

5.1.1 The kinetic energy (in joules, j) of a projectile shall be determined from the following equation:

$$\text{kinetic energy} = 1/2 mv^2$$

where: m = mass of projectile (Kg) and,

v = velocity of the projectile (meter/sec.)

Conversion factor: Meters/sec = .447142 x miles/hour

5.1.2 The mass of projectile (kg) shall be determined by weighing a sample on a laboratory balance. A sufficient sample size (at least 30) of projectiles shall be weighed to determine the average weight plus 3 standard deviations. This upper limit weight in

Kg is used for "m".

5.1.3 The velocity of a projectile (v) shall be determined by firing a sample from the discharge mechanism of the toy projected out in front of the radar gun. Recording m.p.h.). The velocity of the projectile shall be calculated from the expression

$v$  (meters/seconds) = mph x .447142. The value of  $v$  in the equation is the average of five measurements of a given projectile.

### 5.2 Test for Penetration of Toy Projectiles with Stored Energy

#### 5.2.1 Foil

From a roll of aluminum foil, cut out twenty samples measuring 105 mm x 105 mm. Ensure that each sample is free from obvious imperfections including creases or wrinkles. Ten samples of aluminum foil are required to verify the quality of the aluminum foil and ten samples are required to test the toy.

#### 5.2.2 Foil Verification.

- a) The quality of the foil should be verified as follows:
- b) Place one of the samples of foil between the two O-rings of the clamping frame and clamp the foil between the clamps so that the foil diaphragm is evenly tensioned with no creases or wrinkles.
- c) Place the clamping frame on a substantially horizontal surface so that the foil diaphragm makes an angle between 15 degrees and 20 degrees relative to the horizontal.

- d) Position the steel ball so that when the ball is released, it would fall freely through a vertical distance of 300 mm to strike the central 25 mm diameter area of the foil diaphragm.
- e) Examine whether or not the foil diaphragm ruptured, as specified in 5.2.3
- f) If the steel ball does not cause the foil diaphragm to rupture, repeat steps b) to d) a further four times, provided that each time the foil diaphragm does not rupture.
- g) If all five of the foil diaphragms do not rupture, repeat steps b) to d), but this time, drop the steel ball through a height of 500 mm.
- h) If the ball causes the foil diaphragm to rupture, as specified in 5.2.3, repeat steps b) to d) a further four times, provided that each time the foil diaphragm does rupture.

#### 5.2.3 Interpretation

The foil diaphragm shall be considered as not ruptured if the foil shows, without magnification, no split or hole. A mere dent shall not be considered as a rupture.

The foil diaphragm shall be considered as ruptured if the foils shows, without magnification, a split or hole.

The ten remaining foil samples that are to be used to test the toy shall be considered as verified as being of a suitable quality if all five samples that were subjected to the ball drop height of 500 mm did rupture.

#### 5.2.4 Test Specimen

The toy submitted for this test shall be representative of the normal population and shall not have been subjected to any normal use and reasonably foreseeable abuse tests prior to penetration testing the toy.

#### 5.2.5 Procedure

The procedure shall be carried out in a conditional environment as follows:

- a) Place one of the verified foil samples between the two O-rings of the clamping frame and clamp the foil using the clamps so that the foil diaphragm is evenly tensioned with no crease or wrinkles.
- b) Place the clamping frame such that the foil diaphragm lies in a substantially vertical plane.
- c) Load the projectile into the discharge mechanism.



d) Position the toy so that:

- 1) The end of the toy, that is, the end of the projectile or the end of the discharge mechanism whichever protrudes furthest, is 150 mm from the foil diaphragm; and
- 2) When the projectile is ejected, the flight path of the projectile would be substantially normal relative to the foil diaphragm and the projectile would strike the foil's center as possible.

e) Eject the projectile.

f) Observe whether or not the projectile ruptures the foil diaphragm as specified in 5.2.3.

g) Repeat steps a) to f) a further nine times using the other nine verified foil samples.

#### 5.2.6 Report

The report shall state the number of times the projectile ruptured the foil diaphragm when the toy was tested in accordance with 5.2.5.

#### 5.3 Impact Test For Projectiles

Projectiles shall be propelled by their discharge mechanism six times into a concrete block wall (or equivalent surface) located at a distance 1 foot (300 mm) plus the length of the projectile from the front end of the discharge mechanism. The discharge mechanism shall be aimed perpendicular to the wall.

#### 5.4 Use and Abuse Testing

Perform all pertinent use, abuse, life, and environmental testing on the projectile per the appropriate test plan for its parent product.

#### 5.5 Improvised Projectile Test

Determine through experimentation if discharge mechanism is capable of discharging projectiles other than the projectile specifically designed for use with the discharge mechanism. Testing of improvised projectiles shall include, but is not limited to, the following objects:

SRS-045  
PAGE 6 OF 12  
REVISION G

### **DIMENSIONS OF IMPROVISED PROJECTILES**

(All measurements in inches)

A) Correction Pen Cap

Dimensions

- 1) Pentel Opaqing Fluid Correction Pen  
Oil-Based Quick Dry  
18 ml. ZLC1-W

- A1) total length-1.10 inches  
maximum diameter - 0.57 inch  
minimum diameter - .53 inch

Manufacturer: Pentel Co. Ltd.  
Made in Japan

B) Marker

Dimensions

- 1) Pentel Marker  
F50  
Made in Japan

- B1) total length - 3.3 inches  
diameter - 0.91 inch  
  
Tip: length - 0.28; width-0.18 inch  
Tip Body: length - 0.70 inch  
max. diameter-0.65 inch  
min. diameter-0.36 inch

C) Marker Caps

Dimensions

- 1) Fluorescent Pen Cap  
Zebra Pen 2  
Thin Size Cap
- 2) Fluorescent Pen Cap  
Zebra Pen 2  
Thin Size Cap
- 3) Fiber Tip Permanent Marker Cap  
Artline 70 High Performance  
Xylene Free EK-70  
Manufacturer: Shachihata Product  
Made in Japan
- 4) Fiber Tip Permanent Marker Cap  
Artline 70 High Performance  
Xylene Free EK-700  
Manufacturer: Shachihata Product  
Made in Japan

- C1) length - 0.93 inch  
max. diameter - 0.35 inch  
min. diameter - 0.23 inch
- C2) length - 1.82 inches  
max. diameter - 0.58 inch  
min. diameter - 0.28 inch
- C3) length - 1.71 inches  
max. diameter - 0.66 inch  
min. diameter - 0.51 inch
- C4) length - 1.52 inches  
max. diameter - 0.70 inch  
min. diameter - 0.69 inch

D) Paper Clip

Dimensions

- 1) Trigonal Clip  
# Elephant Trigonal  
Art. No. PM121  
Made in China

- D1) length - 1.19 inches  
max. diameter - 0.37 inch  
min. diameter - 0.15  
diameter of wire - 0.04 inch

E) Pen

Dimensions

- 1) Ball Pen Body  
Zebra - New Crystal  
N-5000  
Made in Japan

- E1) length - 4.56 inches  
max. diameter - 0.32 inch  
min. diameter - 0.200 inch

- 2) Ball Pen Body  
Zebra - Hard-Crystal  
N-5100  
Made in Japan

- E2) length - 4.83 inches  
max. diameter - 0.31 inch  
min. diameter - 0.21 inch

- 3) Ball Pen Body  
Bic #C-B-19

- E3) length - 5.32 inches  
max. diameter - 0.29 inch  
min. diameter - 0.24 inch

- 4) Ball Pen Cap  
Zebra N-5000  
Made in Japan

- E4) length - 2.32 inches  
max. diameter - 0.47 inch  
min. diameter - 0.25 inch

- 5) Ball Pen Metal Nozzle  
Zebra - Hard Crystal  
N-5100

- E5) length - 0.46 inch  
max. diameter - 0.22 inch  
min. diameter - 0.13 inch

F) Pen Refill

Dimensions

- 1) Bic #C-B-19

- F1) length - 5.17 inches  
max. diameter - 0.19 inch  
min. diameter - 0.12 inch

- 2) Zebra Ballpoint Pen Refill BR-6A-H-BK

- F2) length 5.48 inches  
max. diameter - 0.12 inch  
min. diameter - 0.09 inch

<u>G) Battery</u>	<u>Dimensions</u>
1) "Energizer" AA	G1) length - 1.74 inches diameter - 0.41 inch
2) "Energizer" AAA	G2) length - 1.97 length diameter - 0.52 inch
3) "Energizer" C Size	G3) length - 1.95 inches diameter - 0.99 inch

<u>H) Marble &amp; Pebble</u>	<u>Dimensions</u>
1) Diameter 1"	H1) diameter - 1 inch
2) Diameter 0.635"	H2) diameter - 0.635 inch
3) Diameter 0.642"	H3) diameter - 0.642

Hazard evaluation of launched improvised projectiles shall include (but is not limited to) the following: Tip radii relative to kinetic energy; for rigid projectiles, the kinetic energy; for non-rigid or resilient tipped projectiles; the kinetic energy density.

#### 5.6 Projectile Configuration Evaluation

Projectiles must not have projections (i.e. ribs, missiles, fins, etc.) that protrude from the main body of the projectile and have the potential to generate a "fishhook" effect. Generally, projections that extend 3/16" or more from the body of the projectile and subtend an angle of 30-90 degrees from the body and are not "blended" to the body will be considered as having the potential to generate a "fishhook" effect and are not acceptable for use on the Hasbro, Inc., products. However, projectiles of a size and/or shape such that they don't penetrate to the full depth of the Hasbro Supplemental Test Fixture (see SRS-004, Figure 2) in their normal flight orientation shall be considered acceptable regardless of configuration. The configuration of all projectiles must be approved by Quality Assurance.

#### 5.7 Unexpected Discharging Of Projectiles

Determine through experimentation if the discharge mechanism is capable of discharging projectiles in an unforeseeable, unexpected, or inordinately delayed fashion. When the projectile is in its normal launching position only the activating button, lever or switch must be capable of discharging the projectile. The actions and movements of the toy during all of its reasonably foreseeable normal play modes must not activate the discharge mechanism.

Also, reasonably foreseeable and normally expected handling or carrying the toy must not activate the discharge mechanism. In addition, the projectile should discharge within a reasonable time period after activation. (see 6.8)

#### 5.8 Projectile Kinetic Energy Density

The projectile kinetic energy density must be determined on all projectiles with a kinetic energy greater than .08joule. The Projectile Kinetic Energy Density is the kinetic energy of the projectile divided by its contact area. On non-rigid (i.e. including resilient tipped) projectiles the contact area is measured by applying a suitable staining agent (e.g. Prussian Blue) to the projectile, firing it at a suitable surface 1 foot away and measuring the area of the residual impression. Area is determined by the following:

$$\begin{aligned}\text{Radius in meters: Area} &= \pi r^2 \\ \text{Radius in inches: Area} &= .0006452 \pi r^2\end{aligned}$$

The kinetic energy density is expressed as joules/area.

#### 5.9 Arrows, Darts and Other "Thrown" Items and Bows

The kinetic energy of arrows, darts and other projectiles intended to be thrown shall be imparted to the projectile by a adult throwing the projectile with the highest reasonably foreseeable velocity. To determine the highest reasonably foreseeable velocity, child testing with children of the highest age for which the toy is intended may be required.

For bows, use an arrow intended for the bow and stretch the bow string, using a maximum force of 8.0 lbs. (35.6 newton), as far as the arrow allows, but to a 28 inch maximum (71 cm).

### 6.0 SPECIFICATIONS

- 6.1 No projectile intended to be fired from the toy shall have sharp edges per SRS-003, sharp points per SRS-002, or parts that fit without compression (i.e. the 1 lb. weight is NOT used) into the Hasbro cylinder per SRS-001. (NOTE: pieces that detach as a result of abuse test and cannot be launched by the discharge mechanism are not projectiles).
- 6.2 No projectile shall have a configuration that generates a "fishhook" effect. (See 5.6).
- 6.3 No projectile fired from a toy shall have a tip radius less than 2 mm (.08 in.). The minimum allowable tip radius increases in direct proportion to the kinetic energy of the projectile per the table below:

**PROJECTILE ENERGY LEVEL    MINIMUM ALLOWABLE TIP RADIUS**

up to .025 joule	2 mm
from .025 to .05 joule	3 mm
from .05 to .10 joule	4 mm
from .10 to .15 joule	5 mm
from .15 to .20 joule	6 mm

NOTE: Any projectile with an energy level of .25 joule or greater must be reviewed and approved by Senior Vice President, Hasbro Quality Assurance.

Projectiles in the form of arrows or darts or other missile-shaped objects that are intended to be thrown by the user must have resilient tips with an impact area of at least 4 cm<sup>2</sup>. (.620 in<sup>2</sup>)

Helicopter rotors and single propellers intended to be powered into vertical or nearly vertical flight by a spring mechanism or similar device must have a ring around the perimeter that complies with all the radii requirements of this section.

- 6.4 Any projectile fired from the toy that has a kinetic energy that exceeds .08 joule (as determined by section 5.1) shall have an impact surface (s) of a resilient material.

NOTE: If the flight characteristics of the projectile are such that it tumbles or turns around in flight when the kinetic energy exceeds .08 joule, then all profile surfaces are to be treated as impact surfaces.

- 6.5 Discharge mechanisms must be unable to discharge hazardous improvised projectiles.
- 6.6 All projectiles must withstand the impact test for projectiles (5.3 above) without the generation of a hazardous condition.
- 6.7 A protective tip shall not be detached from the projectile when subjected to torque/tension test per SRS-006 (i.e. 8 in-lbs torque/20.5 lbs tension) and shall not detach or produce or reveal hazardous points or edges when fired into a solid object according to test procedure described in 5.3 above.
- 6.8 Projectiles must not be discharged in an unexpected fashion. Projectiles must discharge within 4 seconds after launch activation (unless there is ample warning in the form of lights, sounds, etc.)
- 6.9 The Kinetic Energy Density of projectiles must not exceed 1600 joules/m . (See section 5.8).

NOTE: Kinetic Energy Density determination is not required for projectiles with an energy level less than .08 joule.

- 6.10 A toy, when tested in accordance with 5.2, shall not eject a stored energy projectile that results in the rupturing of more than two out of the ten foil diaphragms.
- 6.11 Any subject toy capable of discharging a projectile with a kinetic energy greater than 0.08 joule must carry a cautionary statement on the toy (see SRS-070 - Section 4.8).
- 6.12 All projectiles must meet above specifications both before and after all pertinent use, abuse, life and environmental testing per the appropriate test plan.
- 6.13 Summary of Selected Requirements

Projectile Type	Tip Radii (Section 6.3)	Resilient Tip* (6.4)	K.E.D. (6.9)	Foil Test (6.10)
Rigid	Yes	Yes	No	Yes**
Stored energy	Yes	Yes	Yes*	Yes**
No stored energy	Yes	Yes	Yes*	No

\*Applies only if K.E. is > .08 joule

\*\*Does not apply to disc or saucer type projectiles.

**7.0 REFERENCES**

- 7.1 F963 (ASTM), sections 4.20 and 8.15
- 7.2 Product Safety and Liability Reporter, 8/21/81, pp 645-646
- 7.3 NBS report No. 10-893 "Ocular injury potential of projectile-type toys, 8/1/72
- 7.4 EN71-1: 1998, Sections 4.17 and 8.25
- 7.5 "Guidelines for relating children's ages to toy characteristics", CPSC, 10/7/85, Page 181.
- 7.6 Australian Standard 1647.2-1992, "Children's Toys (Safety Requirements), Constructional Requirements", Section 7.15, Appendix K and Appendix DD.

SRS-045

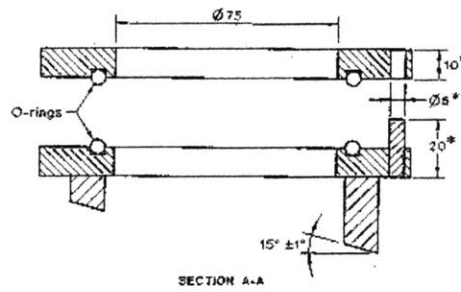
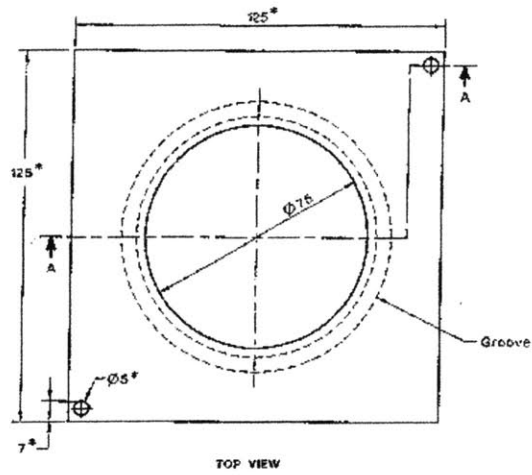

- NOTES:
- 1 The dimensions marked \* shall be within a tolerance of  $\pm 1$  mm.
  - 2 The dimensions not marked \* shall be within a tolerance of  $\pm 0.2$  mm.

DIMENSIONS IN MILLIMETRES

**FIGURE 1**

FIGURE DD1 PLAN VIEW OF CLAMPING FRAME

REVG



SRS-045  
REV G  
FIGURE 2

DISK PROJECTILES

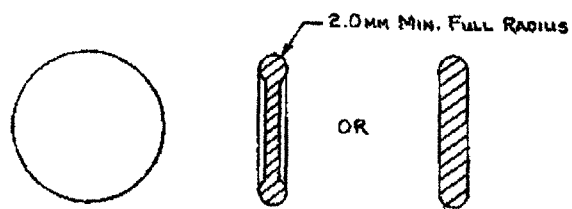

## A.2 Raw Brainstorm Concept List

- Ammunition Collector - means of collecting darts from opponents while playing
- Axe Thrower - launches eccentric ammunition
- Bike Powered Water Blaster - foot pedaling pumps and fires water
- Biodegradable Ammunition - blaster that shoots packing peanut-like ammunition
- Biodegradable Water Balloons - water balloons that biodegrade
- Bladder Blaster - squishy fun-feeling firing
- Blow Dart - foam version of the blow dart
- Booby Trap - foam mine triggered by touch or sensor
- Boomerang Launcher - ammunition that comes back to the user
- Butt Cheek-Zooka - air cannon that looks like a butt
- Camera Tipped Dart - user sees from the point of view of the dart
- Catapult - alternative means of launching
- Cluster Bomb - foam projectile that explodes in the air
- Compost Launcher - for fun yard work
- Confetti Blaster - sprays tiny pieces of paper
- Crossbow - alternative means of launching darts
- Curve Shot - blaster that shoots balls with curved trajectories
- Dancing String Blaster - string appears to wiggle or dance as it exits the blaster
- Dart Tracking - means to find lost darts
- Dimpled Foam Ball - the ammunition is directional like a golf ball
- Directional Megaphone - megaphone that projects to specific locations
- Disk Launcher - shoots foam disks
- Dog Food Launcher - blaster for playtime with dogs
- Electromagnetic Launching - magnets propel darts
- Enlarging Ammunition - ammunition expands when leaving the blaster
- Exploding Target - target that explodes when hit
- Fall-Apart Water Blaster - can be rigged to fall apart on unsuspecting user

- Fart Darts - darts that fly through the air with excessive flatulence
- Foam Artillery - remote launched foam cannon
- Foam Blaster - water blaster that is made of foam for safe play
- Foam Grenade - foam filled ball explodes on impact
- Foam Shotgun - a blaster that shoots several balls at once
- Food Pellet Launcher - fun animal/human toy
- Freeze Blaster - sprays chilled water
- Gatlin Blaster - firing mechanism for launching foam balls
- Glowing Water - uses an additive to make the water glow
- Grapple Blaster - launches a foam grapple hook
- Ground Sky Writer - writes messages in the air with smoke
- Helix Water Stream - two water streams create a helix
- Hopper Fed Launcher - continuous loading feature
- Hose Cannon - water blaster that attaches to the garden hose
- Huge Bubble Maker - creates four-foot diameter bubbles
- Inner Tube Fighter Pod - pool toy with water blasters attached
- Kid Skeet - shoot down your opponent's flying target
- Laser Eye Water Blaster - water blaster with a laser scope attachment
- LED Darts - darts that light up
- Linked Darts - darts that are attached
- Lizard Tongue - sticky hook-shot that can grab and bring back lightweight objects
- Long Foam Noodle Blaster - launches foam pool toys
- Matrix Darts - darts that move slowly through the air
- Mini-Helicopter Launcher - ammunition that ascends in the air when launched
- Mist Blaster - sprays mist and can possibly form snow during winter
- Motion Sensor Water Bomb - water grenade that explodes when someone nears
- Mr. PotatoSoaker - water blaster with fun parts that the user puts together
- Multi-Ball Cannon - a cannon that shoots many balls at once
- Net Blaster - deploys a net

- Paper Airplane Blaster - folds and launches paper airplanes
- Paper Roll Blaster - continuous looping band with air blowing it outward
- Pedaling Launcher - fires and loads by pedaling
- Pogo Blaster - pogo stick is used to pump and fire
- Pool Piston - pool toy with syringe like loading and firing
- Popcorn Blaster - pops and shoots popcorn
- Pulsating Film Blaster - uses a thin rubber film to create water spurts
- Quick Clip Water Balloons - water balloons that do not require tying
- Raft Blaster - pool raft with attached water blasters that feed from the pool water
- RC Missile Launcher - RC car with foam dart launchers
- Real Feel Dart Blaster - vibrates when shooting
- Revolver Dart Blaster - blaster with a six shot barrel
- Rocket Dart - darts that maintain a constant height and velocity when deployed
- Scentzooka - blaster that shoots scented vortices of air
- Shoe Pump - water blaster with pumps that connect to the user's shoes
- Slug Launcher - a blaster that launches fake slugs
- Slushy Blaster - creates frozen water slush and sprays it
- Sneeze Blaster - sprays water and air with a sneeze sound
- Snow Blaster - blaster that shoots snow
- Snowball Launcher - forms and shoots snowballs
- Soaker Tent - enclosed waterproof tent for inside fun
- Soda Blaster - shoots any soda with carbon dioxide pressure
- Sound Cannon - records and shoots sounds and insults
- Sound Effect Darts - darts that make crash noises on impact
- Spiderman Ball Shot - projects foam balls from wrist
- Spiderman Soaker - sprays water from the wrist
- Spinning O-Ring - blaster that launches rings
- Spinning Sling - water blaster that uses centrifugal forces to launch water beads
- Spiral Water Blaster - water sprays out in a spiral

- Sponge Blaster - shoots wet sponges
- Spray Chalk - chalk blaster for color wars or sidewalk painting
- Spy Shot - fiber optics are used to see around corners
- Stilt Power - stilts pump or trigger the water blaster
- String Launcher - shoots lengths of string far distances
- Strobe Darts - strobe attachment makes darts seem frozen in the air
- Tattoo Launcher - launches stick-on pictures
- Timed Water Grenade - water balloon that can be tossed around until the time runs out
- Torpedo Blaster - launches underwater torpedoes
- Trombone Blaster - can change tones and play music while firing
- Underwater Bubble Ring - creates underwater toroidal vortices
- Wall Mounting for Blasters - can hang blasters on wall for storage or remote attacks
- Wash-the-Car Soaker - mixes soap and water and makes car-washing fun
- Water Ball Launcher - water cannon that releases a sphere of water
- Water Balloon Blaster - fills, ties and launches water balloons
- Water Balloon Mine - water grenade that explodes on touch
- Water Blaster Hat - water blaster is attached to a hat so hands can hold more blasters
- Water Dart Blaster - a water blaster that launches foam darts in the water stream
- Water Grenade - timed water balloon
- Water Machinegun - rapidly shoots small water bullets
- Water Sling Shot - propels water with elastic
- Water Swords - swords that spray water
- Water Worm Shooter - a laminar flow water blaster that shoots worm-like segments
- WaterTag Shirts - shirts that change color when hit
- Wet Darts - dart blaster that wets the suction tip of the dart to stick longer
- Wingman - dart that deploys wings in air to increase distance

# Appendix B

## Figures

## B.1 30 Potential Concepts

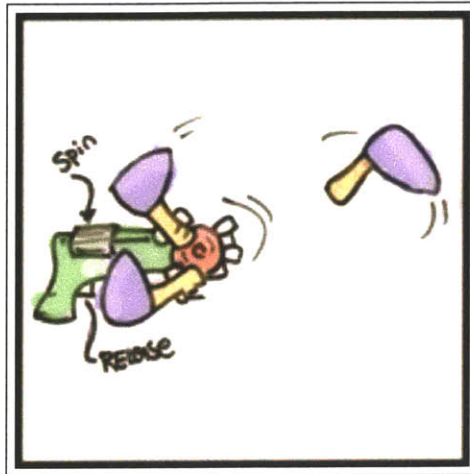

Axe Thrower - This blaster propels foam objects with an eccentricity. The projectile motion resembles that of an axe or hammer being thrown.

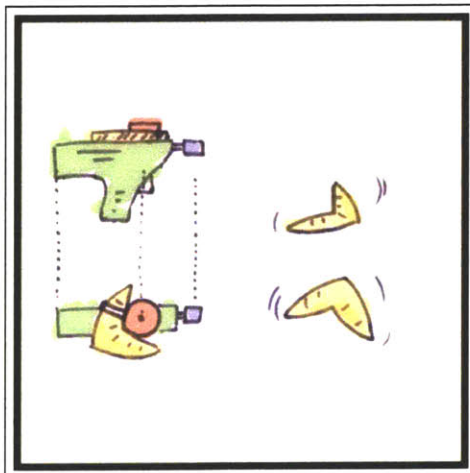

Boomerang Launcher - This blaster propels foam boomerangs that come back to the user.

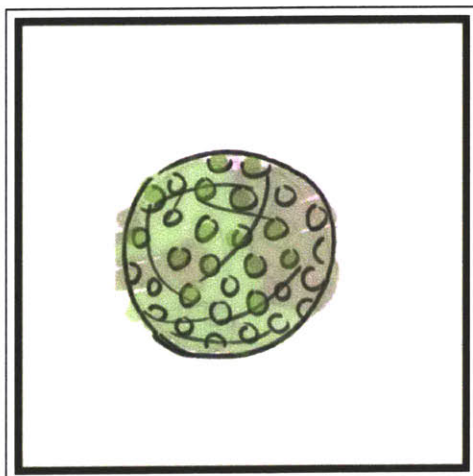

Dimpled Foam Ball - Like a golf ball, the foam is covered in small dimples to allow for further distance and directional shooting.

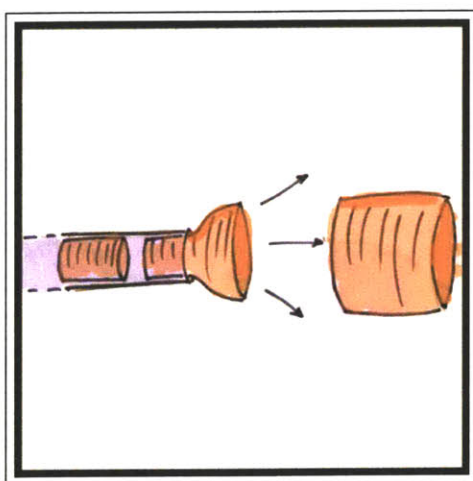

Enlarging Ammunition - Small foam pellets are loaded into the blaster and significantly expand after launch.



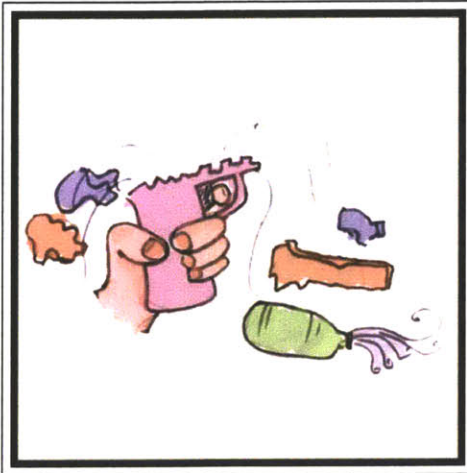

Fall-Apart Blaster - This water blaster falls apart when the trigger is pulled. The water supply then drenches the surprised user and a good laugh is had at their expense.

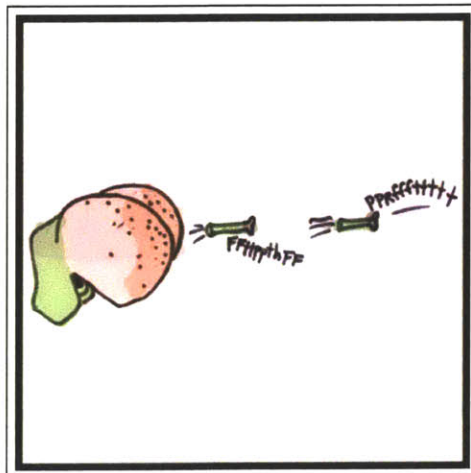

Fart Darts - A reed-like tip in the dart creates a humorous flatulent noise like a flying Whoopee Cushion.

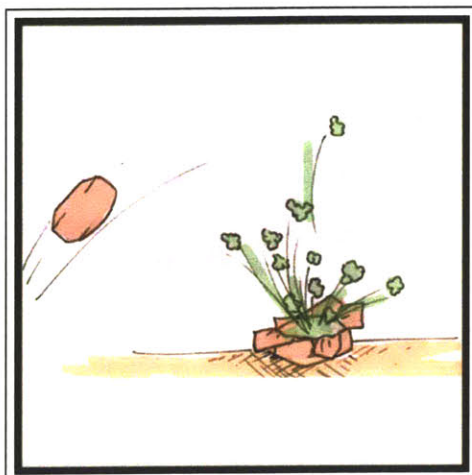

Foam Grenade - This is a soft package filled with small pieces of foam which explodes on impact.

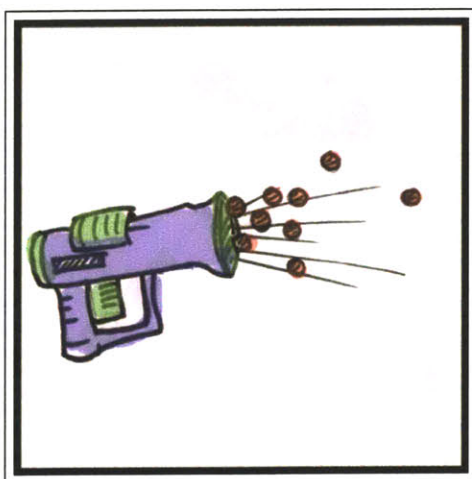

Foam Shotgun - This foam blaster shoots several balls at the same time.

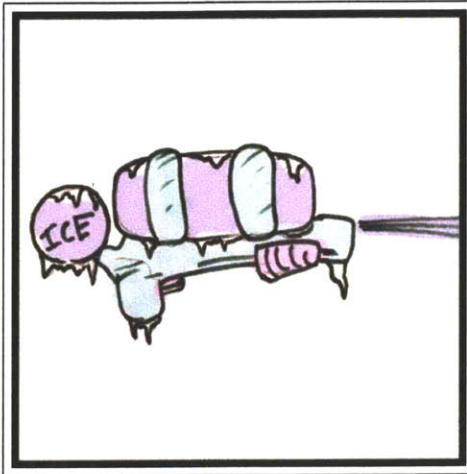

Freeze Blaster - A section of the blaster is kept at a low temperature to spray chilled water.

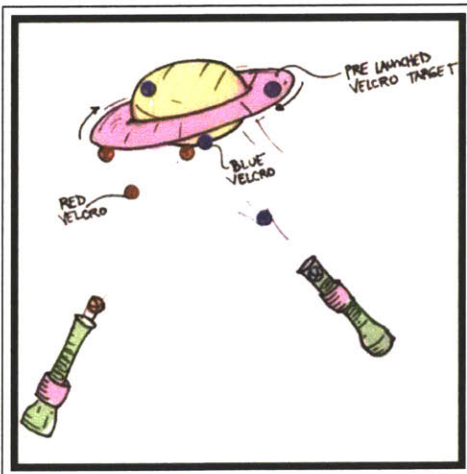

Kid Skeet - A target covered in Velcro hovers or is suspended from the ground. Users shoot down or cover their opponent's target with Velcro-covered foam balls.

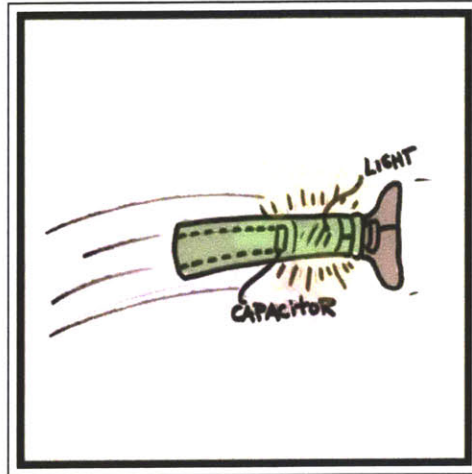

LED Darts - An LED embedded inside the dart body illuminates after exiting the blaster. This produces a tracer effect, most effective during night play.

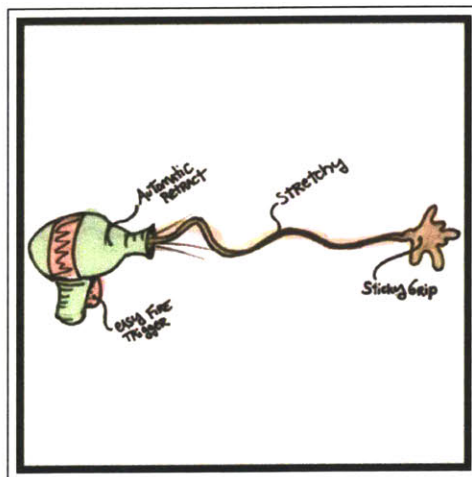

Lizard Tongue - The blaster fires a sticky mass on a cord and immediately recoils it. The hook shot effect is used to grab and retrieve lightweight objects.

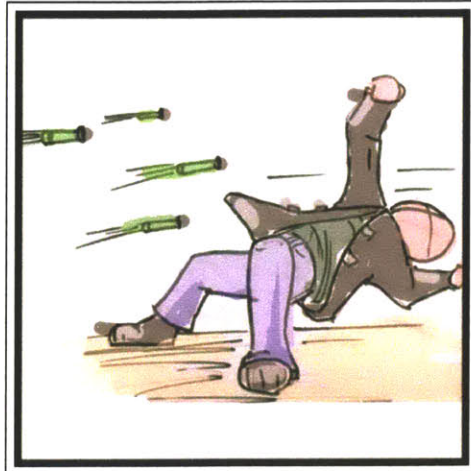

Matrix Darts - These darts move relatively slow through the air producing the effect of slowing down time.

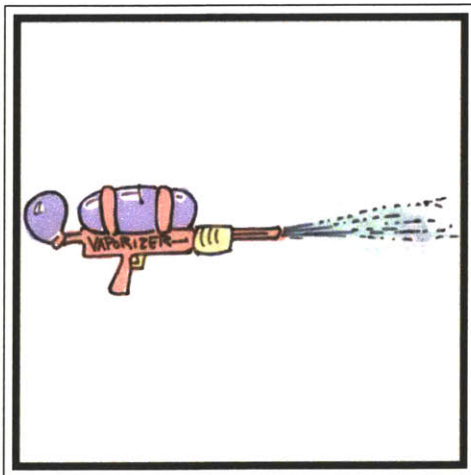

Mist Blaster - The blaster atomizes water allowing the user to spray a concentrated cloud of mist. The water reserve lasts much longer, play can continue indoors, and if temperature permits, the mist can freeze into snow.

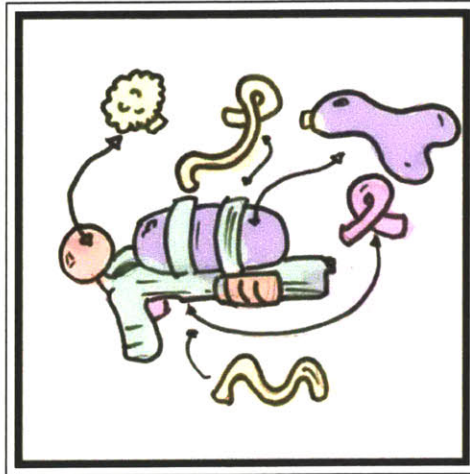

Mr. PotatoSoaker - This allows the user to piece together different water blaster components to make a custom toy.

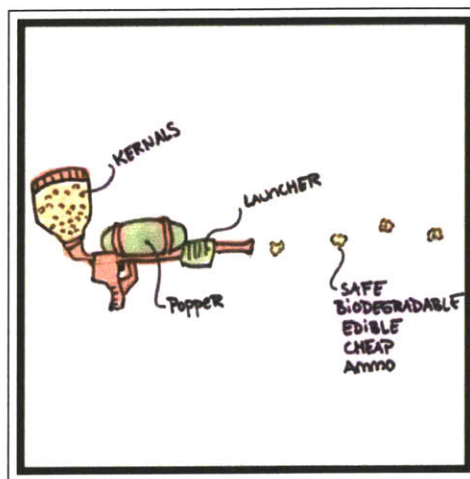

Popcorn Blaster - Popcorn kernels are loaded into a hopper and the blaster pops and shoots one kernel at a time. The ammunition is inexpensive, biodegradable, edible, safe, and can reach far distances.

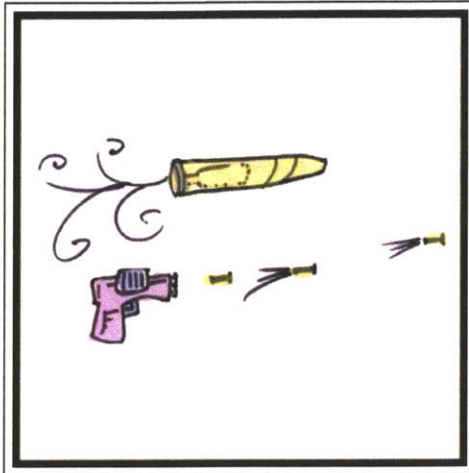

Rocket Dart - Foam darts maintain a constant height and velocity profile. Darts may require an internal bladder for propulsion after firing.

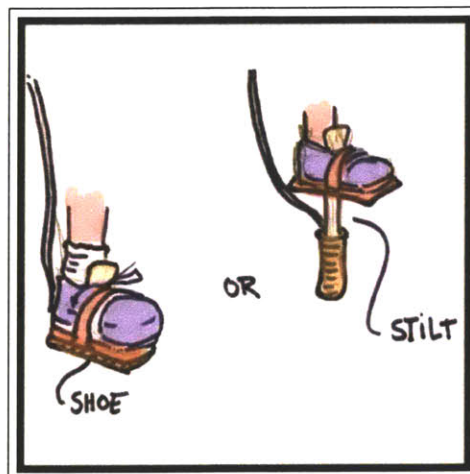

Shoe Pump / Stilt Power - This water blaster transfers the energy of the users running during play to pressurizing the water tank.

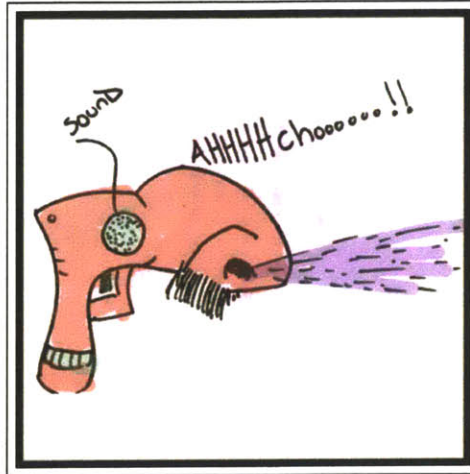

Sneeze Blaster - A fake sneeze effect is achieved by accompanying a blast of water mist with sound effects.

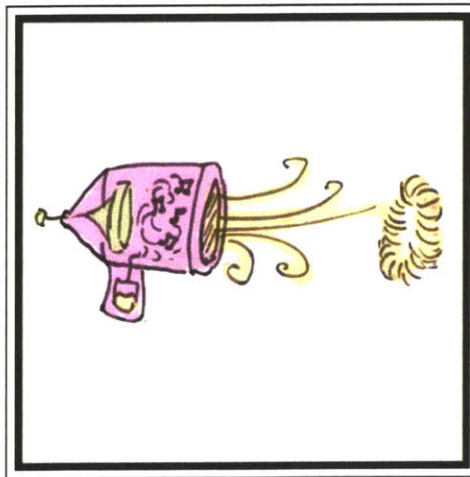

Sound Cannon / ScentZooka - An air-cannon stores and shoots sound or scent vortices.



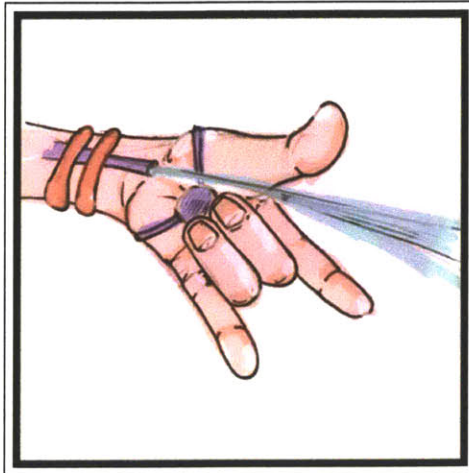

Spiderman Soaker - The water blaster is concealed and a tube transports water to an exit nozzle at the user's wrist. Water is sprayed in a "Spiderman-like" manner.

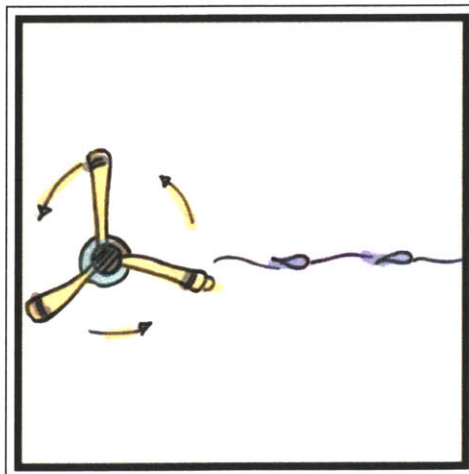

Spinning Sling - The water blaster uses centrifugal force to launch small water beads. The effect is similar to a rapid fire water blaster.

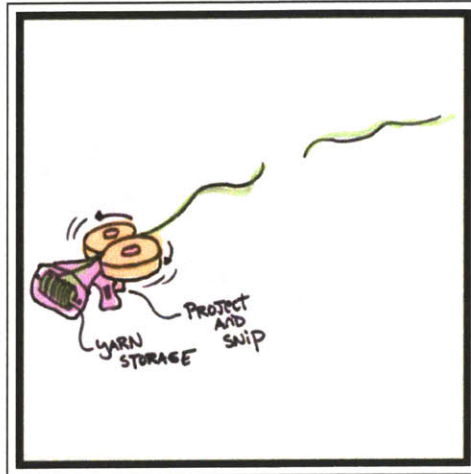

String Launcher - This blaster shoots lengths of string far distances. A desired effect is covering your opponent in a tangled mess of string.

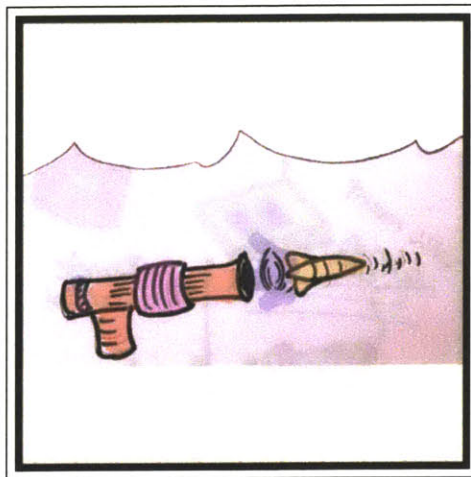

Torpedo Blaster - This blaster is used for underwater play to launch foam torpedoes.

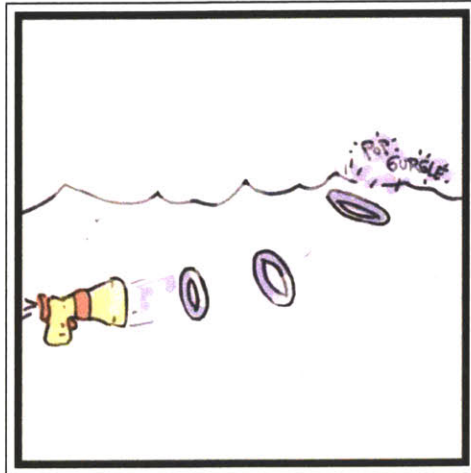

Underwater Bubble Ring - For use underwater, this blaster creates small toroidal vortices that travel large distances.

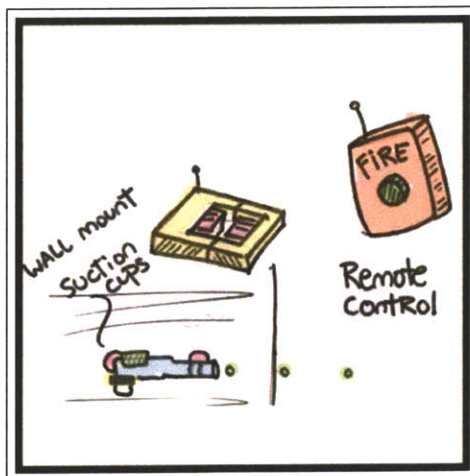

Wall Mounting - Users hang blasters on the wall for storage or remote attacks.

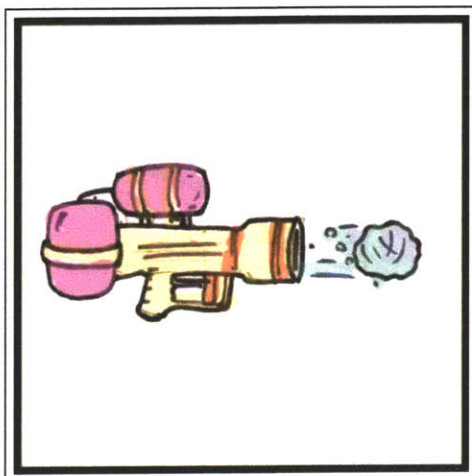

Water Ball Launcher - A blaster or cannon propels a large chunk of water.

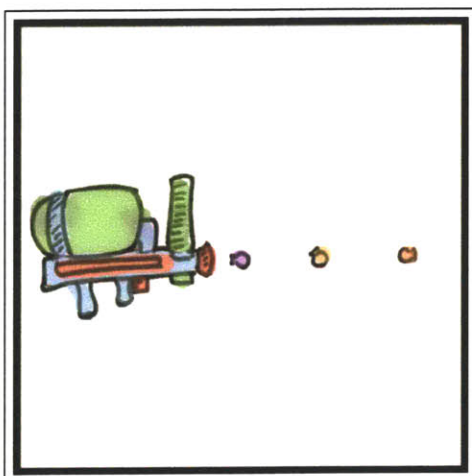

Water Balloon Blaster - Cartridges of small empty balloons are loaded into the blaster. The water blaster fills, seals, and launches individual balloon bullets.

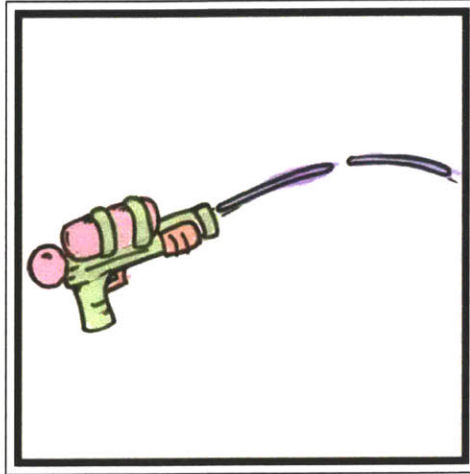

Water Worm Shooter - This water blaster shoots long worm-like segments by cutting a laminar flow stream.

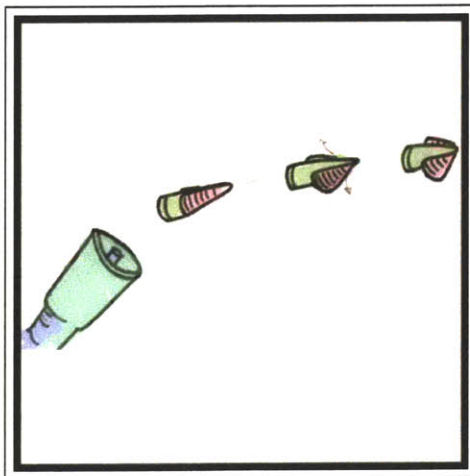

Wingman - Darts deploy wings after firing to increase distance.

## B.2 Final Hand Popper CAD



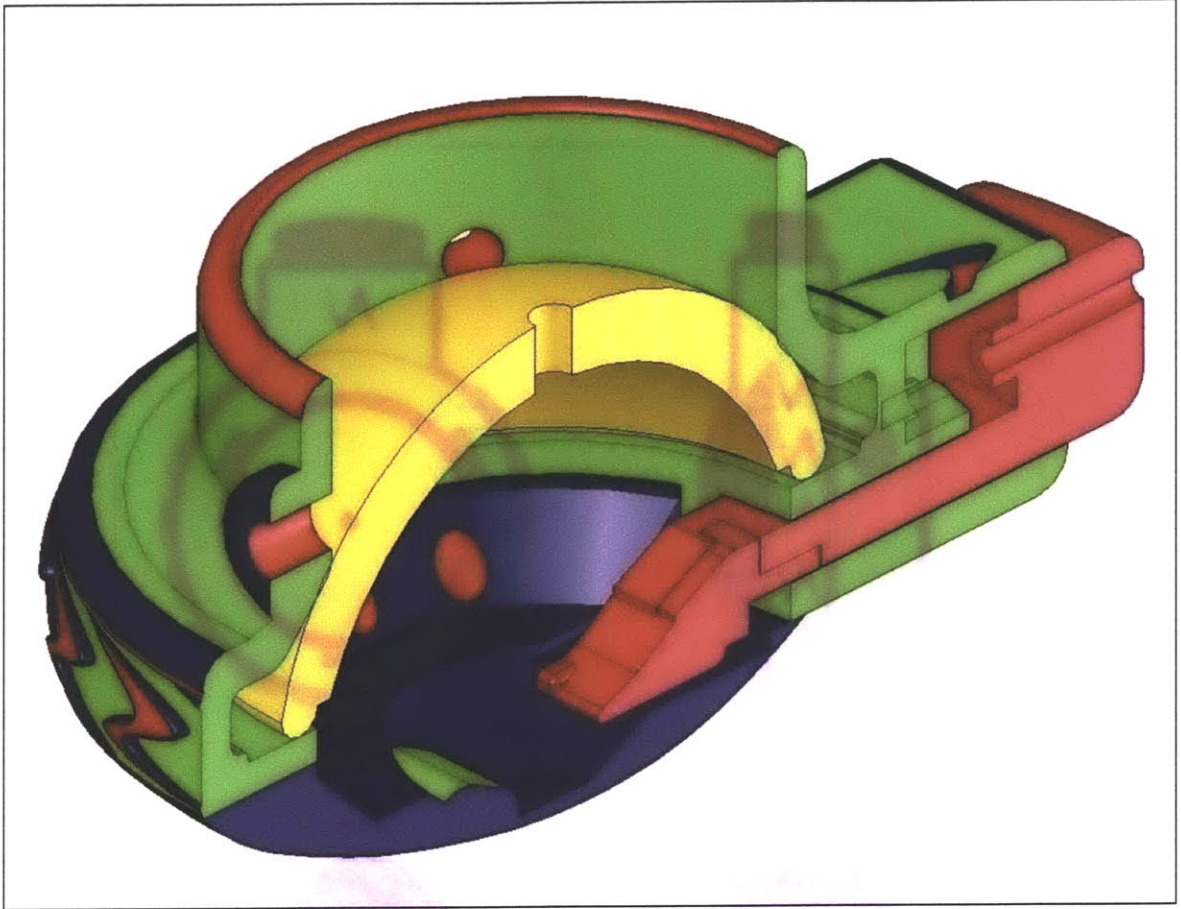

### B.3 Final eDart CAD

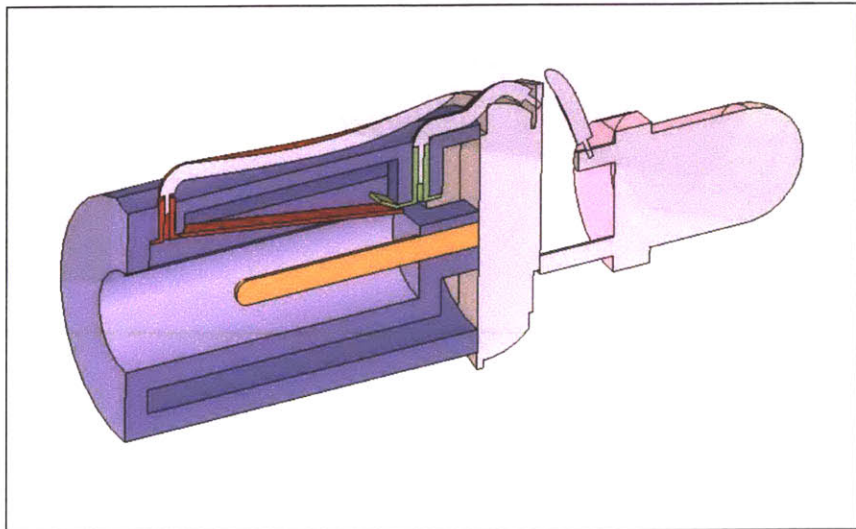
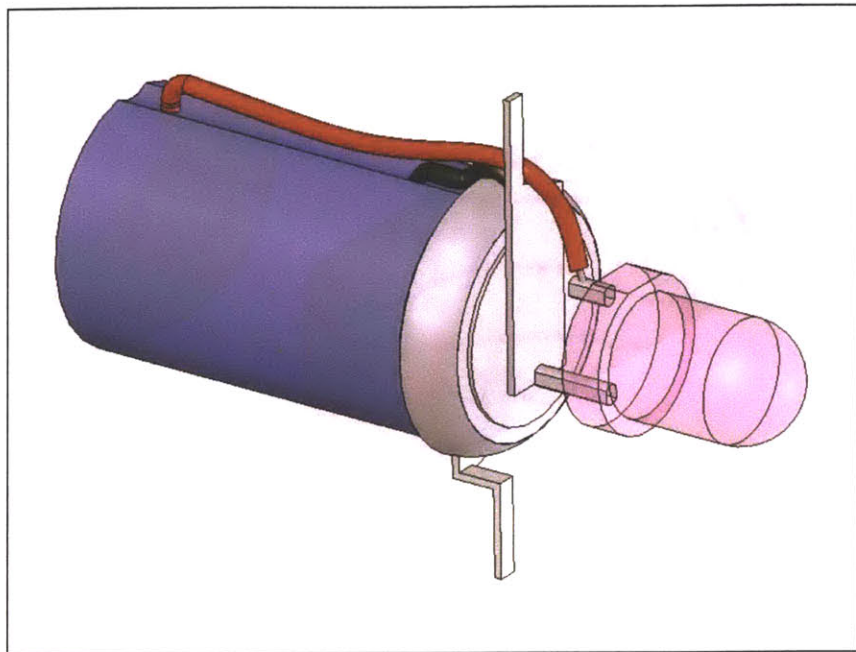



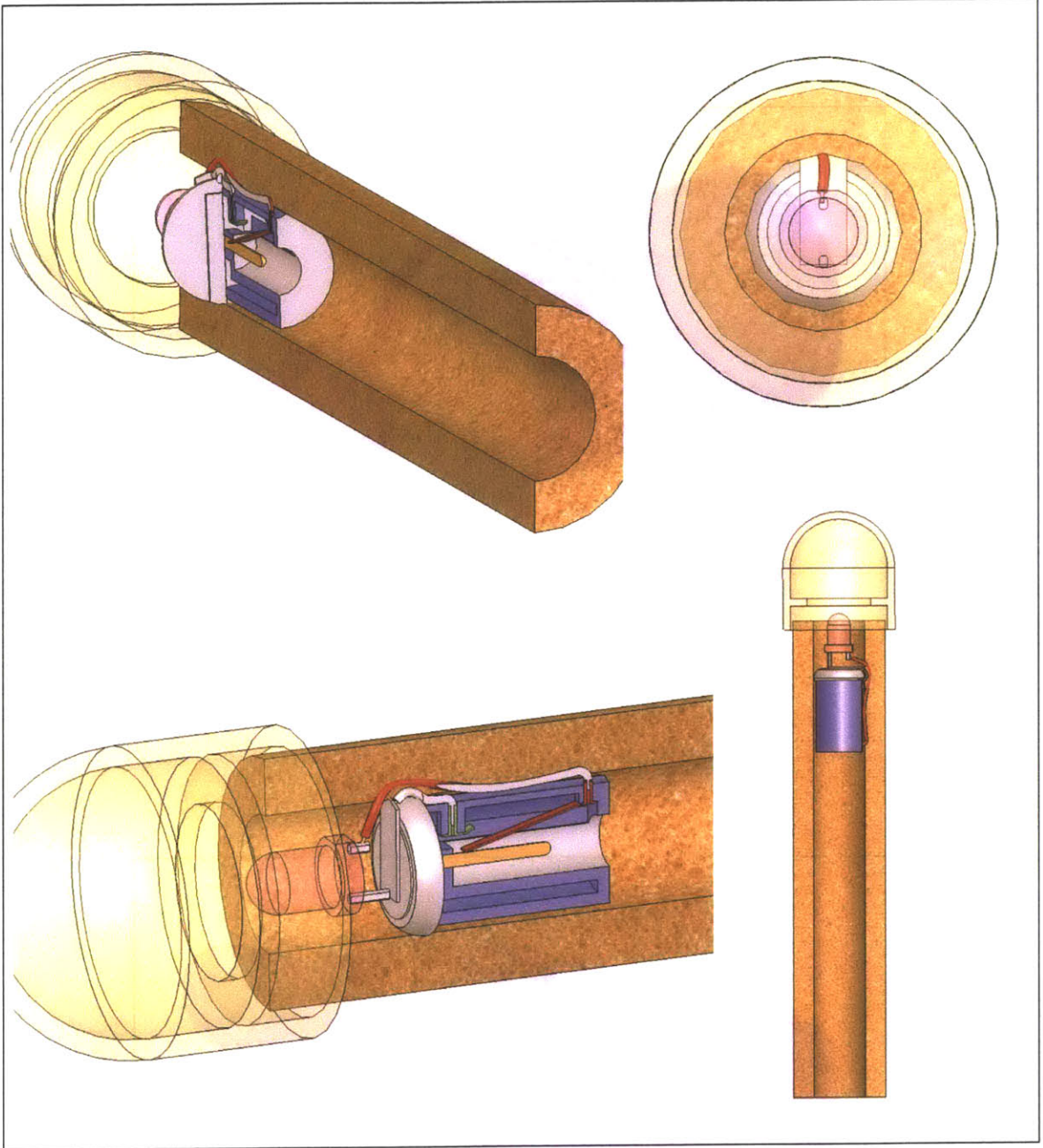

# Appendix C

## MATLab Documents

## C.1 Rocket Dart Mathematical Model

```
%%%%%%%%%%%%%%%%%%%%%%%%%%%%%%%%%%%%%%%%%%%%%%%%%%%%%%%%%%%%%%%%%%%%%%%%%
% Mathematical model of the Rocket Dart trajectory incorporating drag, %
% thrust, and weight components. %
% This program calculates the accleration, velocity and position of the %
% dart over time givin the initial balloon pressure, initial velocity, %
% initial height, and air properties. %
% %
% This program assumes a constant pressure air source allowing %
% for a constant thrust until all the air is expelled %
% %
% Created by Barry Kudrowitz, barryk@mit.edu, 6/22/05 %
% %
%%%%%%%%%%%%%%%%%%%%%%%%%%%%%%%%%%%%%%%%%%%%%%%%%%%%%%%%%%%%%%%%%%%%%%%%%

%close all;
clear;

%%%%%%%%%%%%%%%%%%%%%%%%%%%%%%%%%%%%%%%%%%%%%%%%%%%%%%%%%%%%%%%%%%%%%%%%% Step 1: Initialize Variables %%%%%%%%%%
% %
time_initial = 0; % s
time_final = 2; % s
timestep = 0.025; % s
nstep = (time_final-time_initial)/timestep;

g = 9.8; % m/s^2, acceleration of gravity
rho = 1.27; % kg/m^3,density of air
nu = 1.6*10^(-4); % m^2/s, kinematic viscosity of air
```

```

mass_rocket      = 0.2;           % kg,    dry mass of the rocket
mass_gas         = 0.007;        % kg,    initial mass of gas in the rocket
height_initial   = 2;           % m,    throwing height

V_x_throw        = 8;           % m/s,    initial horizontal throw speed
P_b              = 35000;        % Pa,    (N/m^2), gauge pressure of balloon

C_d_x            = 1.17;        % [],    coefficient of drag for a flat disc
C_d_y            = 0;           % [],    coefficient of drag for a cylinder
diameter         = 0.1;         % m,    diameter of rocket
length           = .7;         % m,    length of rocket
A_exit           = 0.00005;     % m^2,    exit area of the balloon
V_exit           = sqrt(2*P_b/rho); % exit velocity of gas from balloon
mass_flow_rate   = rho*V_exit*A_exit; % kg/s
t_gas            = mass_gas/mass_flow_rate; % time when gas is all expelled

t                = zeros(1,nstep); % time
m                = zeros(1,nstep); % total mass as a function of time
T                = zeros(1,nstep); % thrust as a function of time
D                = zeros(2,nstep); % drag as a function of time
a                = zeros(2,nstep); % acceleration as a function of time
v                = zeros(2,nstep); % velocity as a function of time
x                = zeros(2,nstep); % position as a function of time

a(1,1) = 0; % initial acceleration in the X-direction
a(2,1) = -g; % initial acceleration in the Y-direction
v(1,1) = V_x_throw; % initial velocity in the X-direction
v(2,1) = 0; % initial velocity in the Y-direction
x(1,1) = 0; % initial position in the X-direction
x(2,1) = height_initial; % initial position in the Y-direction

```

```

%
%
%%%%%%%%%%%%%%%%%%%%%%%%%%%%%%%%%%%%%%%%%%%%%%%%%%%%%%%%%%%%%%%%%%%%%%%% End Step 1 %%%%%%%%%%%%%%%%%%%%%%%%%%%%%%%%%%%%%%%%%%%%%%%%%%%%%%%%%%%%%%%%%%%%%%%%%
%%%%%%%%%%%%%%%%%%%%%%%%%%%%%%%%%%%%%%%%%%%%%%%%%%%%%%%%%%%%%%%%%%%%%%%% Step 2: Loop Over Timesteps %%%%%%%%%%%%%%%%%%%%%%%%%%%%%%%%%%%%%%%%%%%%%%%%%%%%%%%%%%%%%%%%%%%%%%%%%
%
%
for i = 2: nstep,
    t(i) = i*timestep;

    if t(i) < t_gas          % t_gas is the time when the gas runs out
        m(i) = mass_rocket + mass_gas - mass_flow_rate*t(i);
        T(i) = mass_flow_rate * V_exit;
    else
        m(i) = mass_rocket;
        T(i) = 0;
    end

    D(1,i) = (1/2)*rho*(v(1,i-1))^2*(pi*diameter^2/4)*C_d_x;

    Re = abs(v(2,i-1))*diameter/nu;

    if Re < .5
        C_d_y = 75;
    elseif Re < 10
        C_d_y = exp(2.2-0.6*log(Re));
    else
        C_d_y = 1;
    end

    D(2,i) = (1/2)*rho*(v(2,i-1))^2*(diameter*length)*C_d_y;

```

```

a(1,i) = (T(i)-D(1,i))/m(i);
a(2,i) = D(2,i)/m(i) - g;

v(1,i) = v(1,i-1) + a(1,i-1)*timestep;
v(2,i) = v(2,i-1) + a(2,i-1)*timestep;

x(1,i) = x(1,i-1) + v(1,i-1)*timestep + (1/2)*a(1,i-1)*timestep^2;
x(2,i) = x(2,i-1) + v(2,i-1)*timestep + (1/2)*a(2,i-1)*timestep^2;

if x(2,i) < 0
    x(1,i) = 0;
    x(2,i) = 0;
    break
end
end

%
%%%%%%%%%%%%%%%%%%%%%%%%%%%%%%%%%%%%%%%%%%%%%%%%%%%%%%%%%%%%%%%%%%%%%%%%%% End Step 2 %%%%%%%%%%%%%%%%%%%%%%%%%%%%%%%%%%%%%%%%%%%%%%%%%%%%%%%%%%%%%%%%%%%%%%%%%%%

%%%%%%%%%%%%%%%%%%%%%%%%%%%%%%%%%%%%%%%%%%%%%%%%%%%%%%%%%%%%%%%%%%%%%%%%%% Step 3: Report Results %%%%%%%%%%%%%%%%%%%%%%%%%%%%%%%%%%%%%%%%%%%%%%%%%%%%%%%%%%%%%%%%%%%%%%%%%%%
%
figure(1) plot(x(1,:),x(2,:),'r.') xlabel('distance [m]')
ylabel('height [m]') title('height versus distance')
%
%%%%%%%%%%%%%%%%%%%%%%%%%%%%%%%%%%%%%%%%%%%%%%%%%%%%%%%%%%%%%%%%%%%%%%%%%% End Program %%%%%%%%%%%%%%%%%%%%%%%%%%%%%%%%%%%%%%%%%%%%%%%%%%%%%%%%%%%%%%%%%%%%%%%%%%%

```

## C.2 Trajectory of Dart with Given Mass

```
%Trajectory of Dart with given dart mass
%Projectile Motion: Using an adaptation of the Euler method
(keeping %second order terms) by Amanda Bligh

clear all;

%user input values

m=input('Input Mass(kg): '); %Mass of projectile
d=.011;
dimpact=.011; %dart impact-area diameter
Aimpact=(.5*dimpact)^2*pi; A=(.5*d)^2*pi;
%A=input('Input Frontal Area(m^2): ');
%Frontal area of projectile
theta=35;
%theta=input('Input Initial Angle(deg): ');
%Initial angle at take off
v_0=sqrt(1600*Aimpact*2/m);
%v_0=input('Input Initial Absolute Velocity (m/sec): ');
%Initial velocity at take off
%s=input('Type of Surface (1=Rounded Nose(L/D^4), 2=Suction Cup,
3=Flat Faced Cylinder(L/D^4)):''); %Select fronal surface
s=1;

%constants
if s==1 | s==2 | s==3 %defining drag coefficient based on shape
if s==1
    C=.68;
```

```

end if s==2
    C=1.4;
end if s==3
    C=.87;
end else
    disp ('Read the directions dunderhead!');
end

    %Drag coefficient
p=1.2;    %Density of air (kg/m^3)
g=9.81;   %Acceleration due to gravity (m/s^2)
pos=[0,1.5]; %Starting position of projectile (m) [x,y]

%calcs

rads=pi*theta/180;    %changing deg to rads
v_comp(2)=v_0*sin(rads); %y-component of velocity
v_comp(1)=v_0*cos(rads); %x-component of velocity
drag=p*A*C/2;        %air resistance

maxstep= 1000;        %Max number of calculated values
timestep= .01;        %Increment of time

for i=1:maxstep
    x_pos(i) = pos(1);    %creating a x-position matrix
    y_pos(i) = pos(2);    %creating a y-position matrix
    a(1)=-((drag*sqrt(v_comp(1)^2+v_comp(2)^2)*v_comp(1))./m);
    %creating a acelleration matrix (x-direction)
    a(2)=-((drag*sqrt(v_comp(1)^2+v_comp(2)^2)*v_comp(2))./m)-g;

```



```

%adding y-direction to the acelleration matrix
pos=pos+v_comp.*timestep+.5.*a.*timestep^2;
%finding new position value
v_comp=v_comp+timestep.*a;
%finding new velocity value
%disp(x_pos(i));
%disp(y_pos(i));
if(pos(2)<0)      %stopping when y is less than zero
    break
end
end
x_pos(i+1)=pos(1); %finding final value of x
y_pos(i+1)=pos(2); %finding final value of y

grid on;
plot(x_pos, y_pos); %plotting y vs x position
%axis([0 20 0 10]); %axis setting

xlabel('Distance (m)'); ylabel('Height (m)');

disp('Flight Distance:');

feet=x_pos(i+1)*3.28; %changing the largest x-value to feet
disp(feet);          %disply the largest x-value

```

### C.3 Maximizing Dart Distance with a Given Impact Diameter

```
%Maximizing Distance with user input of impact diameter
%Projectile Motion: Using an adaptation of the Euler method
(keeping %second order terms)by Amanda Blight, modified by William Fienup
clc; clear all; format long;

%user input values
disp('please input the impact-area diameter in meters, as a
reference, ') disp ('here are the impact-area diameters of the
following tips:'); disp('new clear tip =.02, old tip=.015, dart no
tip=.011'); dimpact=input('input: '); count=1; maxdistance=0;
bestmass=0;
m=0.0000; %start Mass of projectile
d=.011; Aimpact=(.5*dimpact)^2*pi; A=(.5*d)^2*pi;
%A=input('Input Frontal Area(m^2): '); %Frontal area of projectile
theta=35;
%theta=input('Input Initial Angle(deg): '); %Initial angle at take off
v_0=sqrt(1600*Aimpact*2/m);
%v_0=input('Input Initial Absolute Velocity (m/sec): ');
%Initial velocity at take off
%s=input('Type of Surface (1=Rounded Nose(L/D~4), 2=Suction Cup,
3=Flat Faced Cylinder(L/D~4)):'); %Select fronal surface
s=1;

%constants
if s==1 | s==2 | s==3 %defining drag coefficient based on shape
if s==1
```

```

        C=.68;
end if s==2
        C=1.4;
end if s==3
        C=.87;
end else
        disp ('Read the directions dunderhead!');
end

        %Drag coefficient
p=1.2;   %Density of air (kg/m^3)
g=9.81;  %Acceleration due to gravity (m/s^2)
pos=[0,1.5]; %Starting position of projectile (m) [x,y]
maxdis=[50,.0006];
%calcs

rads=pi*theta/180;      %changing deg to rads
v_comp(2)=v_0*sin(rads); %y-component of velocity
v_comp(1)=v_0*cos(rads); %x-component of velocity
drag=p*A*C/2;          %air resistance

maxstep= 1000;
%Max number of calculated values
timestep= .01;         %Increment of time
for gd=1:maxstep for i=1:maxstep
        x_pos(i) = pos(1);      %creating a x-position matrix
        y_pos(i) = pos(2);      %creating a y-position matrix
        a(1)=-((drag*sqrt(v_comp(1)^2+v_comp(2)^2)*v_comp(1))./m;
                %creating a acelleration matrix (x-direction)

```

```

a(2)=-((drag*sqrt(v_comp(1)^2+v_comp(2)^2)*v_comp(2))./m)-g;
    %adding y-direction to the acelleration matrix
pos=pos+v_comp.*timestep+.5.*a.*timestep^2;
    %finding new position value
v_comp=v_comp+timestep.*a;    %finding new velocity value
if(pos(2)<0)    %stopping when y is less than zero
    break
end
end
x_pos(i+1)=pos(1); %finding final value of x
y_pos(i+1)=pos(2); %finding final value of y

%axis([0 20 0 10]); %axis setting

feet=x_pos(i+1)*3.28; %changing the largest x-value to feet

x_maxdis(gd+1)=m; y_maxdis(gd+1)=feet;

m=m+.00005; %mass step
i=0; pos=[0,1.5];

    %Drag coefficient
p=1.2; %Density of air (kg/m^3)
g=9.81; %Acceleration due to gravity (m/s^2)
pos=[0,1.5]; %Starting position of projectile (m) [x,y]

%calcs
v_0=sqrt(1600*Aimpact*2/m);
rads=pi*theta/180; %changing deg to rads
v_comp(2)=v_0*sin(rads); %y-component of velocity

```

```

v_comp(1)=v_0*cos(rads); %x-component of velocity
drag=p*A*C/2;

for i=1:maxstep
    x_pos(i) = pos(1); %creating a x-position matrix
    y_pos(i) = pos(2); %creating a y-position matrix
    a(1)=-((drag*sqrt(v_comp(1)^2+v_comp(2)^2)*v_comp(1))./m);
    %creating a acelleration matrix (x-direction)
    a(2)=-((drag*sqrt(v_comp(1)^2+v_comp(2)^2)*v_comp(2))./m)-g;
    %adding y-direction to the acelleration matrix
    pos=pos+v_comp.*timestep+.5.*a.*timestep^2;
    %finding new position value
    v_comp=v_comp+timestep.*a; %finding new velocity value
    if(pos(2)<0) %stopping when y is less than zero
        break
    end
end

x_pos(i+1)=pos(1); %finding final value of x
y_pos(i+1)=pos(2); %finding final value of y

%axis([0 20 0 10]); %axis setting

feet2=x_pos(i+1)*3.28; %changing the largest x-value to feet
x_maxdis(gd+2)=m; y_maxdis(gd+2)=feet2;

if (feet2<feet & count==1)
    count=2;

```

```

    maxdistance=feet;
    bestmass=m;
end
if (m>.0035) %stops at .0035 kg
    disp('max distance (ft) is:');
    disp(maxdistance);
    disp('with the Mass (kg) of:');
    disp(bestmass);
    xlabel('Mass (g)');
    ylabel('Distance (meters)');
    title('axes title');
    plot(x_maxdis*1000, y_maxdis*.3048);
    %last minute conversion to grams and meters cause Metric rules
    break
end
end
end

```



# Appendix D

## Tabular Data



## D.1 String Shooter Data

**String Shooter Projectile Distances**

	Projectile (Launched at 24 Degrees)	Horizontal Distance (ft) accurate to 1 ft
String	nylon 6"	22
	rubber 6"	39
	plastic glow 6"	26
	AVERAGE	29
Darts	dart 1	51
	dart 2	54
	dart 3	60
	AVERAGE	55
Various	AA Battery	7
	Ball Point Pen	22
	Pen Cap	34
	Large Paper Clip	55

**Average Distance Reached by Projectiles Launched from String Shooter**

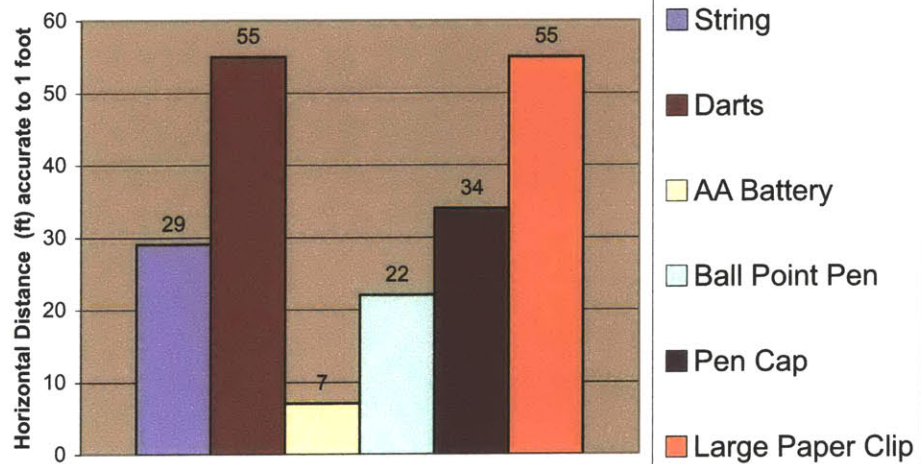

## D.2 Hand Popper Force Data

Loading and Triggering Force Comparison									
Original Delrin Popper Device	Loading Force (lbs)				Triggering Force (lbs)				
		popper 1	popper 2	popper 3	average	popper 1	popper 2	popper 3	average
	With Soft Popper Centered	23	28	22	24.3	2	3	4	3
	With Soft Popper Off-Centered	36	38	28	34.0				
	With Hard Popper Centered	36	30	33	33.0				
With Hard Popper Off-Centered	42	33	38	37.7					
Hand Popper (Version 1)	Loading Force (lbs)				Triggering Force (lbs)				
		popper 1	popper 2	popper 3	average	popper 1	popper 2	popper 3	average
	With Soft Popper Centered	28	28	26	27.3	3	5	4	4
	With Soft Popper Off-Centered	36	40	34	36.7				
	With Hard Popper Centered	28	28	36	30.7				
With Hard Popper Off-Centered	40	36	46	40.7					
Hand Popper (Version 2 with cylindrical channel)	Loading Force (lbs)				Triggering Force (lbs)				
		popper 1	popper 2	popper 3	average	popper 1	popper 2	popper 3	average
	With Soft Popper	28	28	26	27.3	3	3	3	3.00
With Hard Popper	28	28	35	30.3					
Nerf Ball Blaster		10	10	12	10.7	22	18	20	20.0
Averages									
Soft Centered	Hard Centered								
26.3	31.3								
Soft Off-Centered	Hard Off-Centered								
35.3	39.2								
Sketch Model Prototype	Hand Popper V1								
32.3	33.8								
Hand Popper V2	Nerf Ball Blaster								
28.8	10.7								
Nerf Ball Blaster Firing									
20.0									
Hand Popper V2 with Talcum Powder Lubricant									
with soft popper	18	19	18	18.3	Average				
with hard popper	20	18	18	18.7	18.5				
change in force from powder									
with soft	10	9	8	9.0					
with hard	8	10	17	11.7					

**Raw Data from Vertical Height Testing for Hopper Popper Mechanisms**

Popper Type	Vertical Height (ft) accurate to a half foot			
	hard popper 1	hard popper 2	soft popper 1	soft popper 2
popper (free)	17.5	17.5	16	15.5
popper (in hand)	17	16.5	15.5	15.5
delrin sketch model	14	14	13.5	14
sls iteration 1	15	15	13.5	14.5
sla iteration 2	16	15	14	14
sla iteration 2 with powder	17.5	17	15.5	15
Ball Blaster				

	Hard Average	Soft Average	Total Average	Average Distance if fired at 45
popper (free)	17.5	15.75	16.6	33.25
popper (in hand)	16.75	15.5	16.1	32.25
delrin sketch model	14	13.75	13.9	27.75
sls iteration 1	15	14	14.5	29
sla iteration 2	15.5	14	14.8	29.5
sla iteration 2 with powder	17.25	15.25	16.3	32.5
Ball Blaster			13	26

## D.4 Hand Popper Part Comparison

**Hand Popper and Ball Blaster Part Count Comparison**

Handle 1	1	Body Half	1
Handle 2	1	Body Half	1
Body 1	1	Hopper Popper	1
Body 2	1	Trigger	1
Alignment Pin	1	Return Spring	1
Piston Cylinder	1	Screws	6
Piston Cylinder Cap	1		
Spacer	1	Hand Popper Parts	11
Clear Body Tube	1	Hand Popper Parts (no fasteners)	5
Plastic Stop on Tube	1		
Back of Piston Cap inner	1		
Back of Piston Cap outer	1		
Back of Piston Gasket	1		
Spring	1		
Spring Cap	1		
Piston Cap Inner	1		
Piston Cap Outer	1		
Piston Gasket	1		
13 outer screws	13		
8 inner screws	8		
total screws	21		
Ball Blaster Total Parts	39		
Ball Blaster Total Parts (no fasteners)	18		

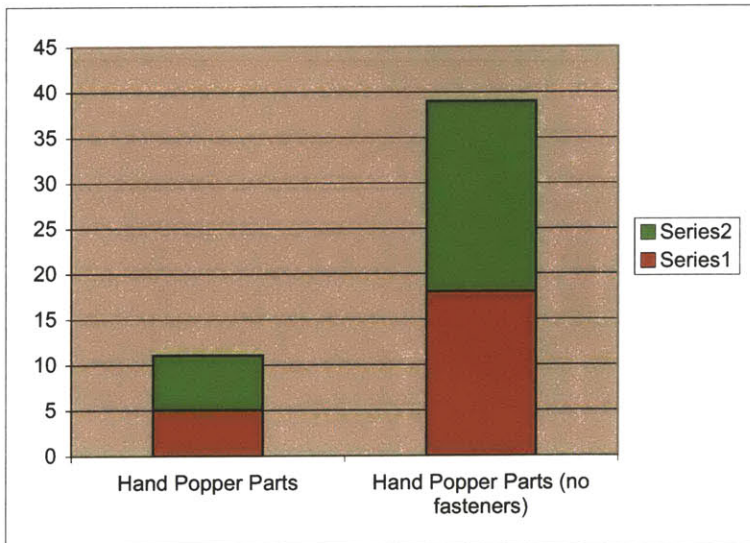

## D.5 Dart Mass Data

Mass of 2nd Iteration eDarts and Component Masses				
Part	Mass (g)	with cap (g)	overall mass minus components	
Back Illuminating	2.3029	2.922	0.065	(wire and solder)
Front illuminating	2.5549	3.174	0.111	(wire and solder)
Impact	2.1365	2.755		
Blinking	2.4604	3.079		
Standard		1.250	0.3814	(glue)
Average 2nd Iteration eDart		2.982		
2nd Iteration Components				
cap		0.6186		
body		0.2498		
resistor no pins		0.03		
capacitor		0.9846		
trans (no pins)		0.1552		
SLS insert		0.3406		
shrink tubing		0.217		
large LED (no pins)		0.303		
small LED (no pins)		0.0975		
shim		0.0444		
Just Components of 2nd Iteration				
back lit		2.8565		
front lit		3.062		
standard		0.8684		

### Component Mass Comparisons

Front Lit	mass (g)
Rubber Cap	0.619
Foam Body	0.250
Resistors	0.060
Capacitor	0.985
Transistor	0.155
SLS Insert	0.341
Shrink Fitting	0.217
LED	0.303
Shim Contacts	0.133
Other	0.111
<b>Total</b>	<b>3.174</b>
<b>total - other</b>	<b>3.062</b>

Back Lit	mass (g)
Rubber Cap	0.619
Foam Body	0.250
Resistors	0.060
Capacitor	0.985
Transistor	0.155
SLS Insert	0.341
Shrink Fitting	0.217
LED	0.098
Shim Contacts	0.133
Other	0.065
<b>Total</b>	<b>2.922</b>
<b>Total - other</b>	<b>2.857</b>

Standard	mass (g)
Rubber Cap	0.829
Foam Body	0.250
Glue	0.172
<b>Total</b>	<b>1.250</b>
<b>Total - other</b>	<b>1.078</b>

Suggested Final eDart	mass (g)	
Rubber Cap	0.558	20 mm impact dia cap
Foam Body	0.250	
Glue	0.172	assuming same as standard
Housing	0.162	assuming p.p. density
Contacts/Wire	0.050	
LED	0.067	
Capacitor	0.187	smaller capacitor
<b>Total</b>	<b>1.258</b>	

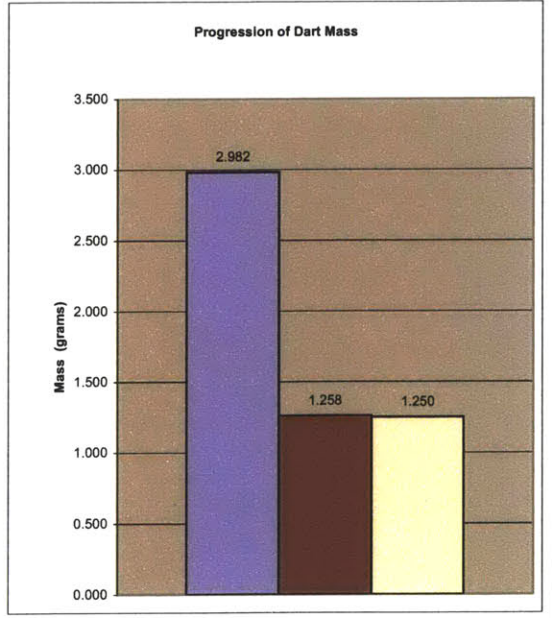
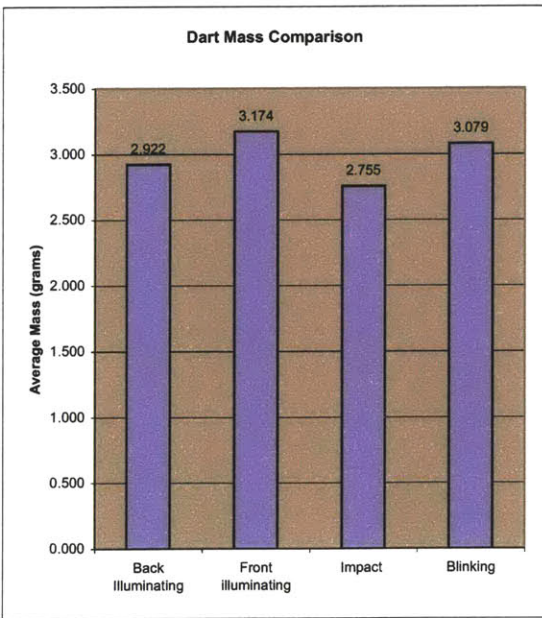



# Bibliography

- [1] C. Fischer. Corporate quality assurance, safety and reliability specifications, srs-045: Projectiles. Technical report, Hasbro Incorporated, Pawtucket, RI, 1999.
- [2] Robert W. Fox and Alan T. McDonald. *Introduction to Fluid Mechanics*. John Wiley & Sons, New York, fifth edition, 1998.
- [3] Tom Harris. How snow makers work. Available on the Internet: <http://science.howstuffworks.com/snow-maker.htm>, 2005.
- [4] Hasbro Incorporated. Official website. <http://www.hasbro.com>, 2005.
- [5] Lonnie Johnson. History of the super soaker. Available on the Internet: <http://www.isoaker.com>, 2000.
- [6] Milivoje Kostic. The art of signal sampling and aliasing. In *NIWeek99 Annual International Conference Proceedings CD*, 1999.
- [7] Matt Michal. Nerf center review. Available on the Internet: <http://www.nerfcenter.com>, 2003.
- [8] Gerhard Pahl and Wolfgang Beitz. *Konstruktionslehre*. Springer-Verlag, Berlin, 1977.
- [9] Alexander H. Slocum. *Precision Machine Design*. Society of Manufacturing Engineers, Dearborn, Michigan, 1992.
- [10] Zia Sobhani. Improving distance for cps 4100 through flow straightener design. Technical report, Hasbro Incorporated, Pawtucket, RI, 2003.



- [11] Karl Ulrich and Steven Eppinger. *Product Design and Development*. McGraw Hill, Boston, third edition, 2004.