

A DESIGN AND CONSTRUCTION OF A MICROWAVE ACCELERATOR

Staff Professor J C Slater
 Professor A F Kip
 Dr W H Bostick
 Dr J Halpern
 R J Debs
 P T Demos
 H Labbitt
 B Lax
 L. Maier
 S J Mason
 I Polk
 J R Terrall

The last Progress Report gives an account of the reasons building a microwave accelerator and of the plans which had been developed for building a full-scale test model. This model is to be 20 ft long and is expected to give electron energies of the order of 30 Mev. It is expected that all of the problems of building a much longer tube will be met in this test model, and that work on it will provide most of the necessary information for building any desired size of machine in the future. It is the purpose of this report to state the progress which has been made on the various problems connected with the design and construction of the 20-foot model.

The Accelerator Tube A series of measurements have been made on the effects of small changes in the dimensions of the iris-type accelerator tube. From these tolerance measurements it is possible to predict the exact dimensions which will give a satisfactory resonant frequency and an arbitrary degree of coupling between sections. A method of fabrication has been developed and a one-foot length (containing 6 sections) has been built in the same fashion as will be the final tube. The method of construction consists of soldering together lengths of copper tube (of 4" inner diameter and 3/8" thickness) with the irises placed between each junction of the copper tubes. The soldering operation is very critical in that any defects in the joints may seriously affect the electrical characteristics of the tube. It has been found that very good joints can be obtained by placing 2-mil BT (silver-copper) foil in the joints to be soldered, and then heating in a hydrogen oven. Since the entire 20-foot tube cannot be soldered all at once, it is planned to build up the tube in suitable sections and to join them at the iris. Irises at the ends of sections will be made of half the normal thickness so that upon being joined to the adjacent section, a normal iris will be formed. This method avoids the need for soldering sections together since no current will flow across the split iris.

The first one-foot length has already been tested in preliminary fashion. It is found to have an unloaded Q of about 14 000, and the frequencies of the various modes are found to occur as predicted by theory. This section will be used to determine final dimensions of the coupling hole through which the magnetron power is coupled and to make various other preliminary measurements before longer sections

are constructed

Mode and Field Testing In connection with the problems of identifying the nature of various modes which are obtained and of measuring the fields set up by the microwave power in the cavities a number of conventional methods (e g various types of probes) have been used In addition a very useful new method has been developed which not only shows the type of mode but will in fact measure the magnitude of the field at any required point in the cavity Upon suitable calibration this field measurement can be made absolute

This new test method makes use of the fact that if the volume of a resonant cavity is changed by a small amount the frequency of resonance is shifted and this frequency change depends on the percentage volume change and on the field strength in the volume removed Thus a very small metal ball (of the order of 1 mm diameter) is introduced into a resonating cavity and the shift of resonant frequency is measured As the ball moves through regions of various field strengths, the frequency shift is proportional to the square of the field in each region This method will be particularly useful in testing sections of the iris tube since a great deal can be learned about the field without making undesired extra holes for probes (The ball can be introduced through the iris openings by mounting it on a fine thread)

Also under consideration is the possibility of extending this method by using materials which perturb either the electric or magnetic field alone and thus permit separate measurement of each field This will lead to measurements of the dielectric properties of small amounts of material at microwave frequencies

The Electronics of the Beam Experimentally the study of the electron beam problem has been advanced by the building of an analyzer for measuring the energy spectrum of an electron beam This analyzer is attached to a 250,000-volt Van de Graff generator in a manner which will allow the electron beam to pass through an accelerating field in a microwave cavity Thus measurements of the acceleration in the cavity can be made under various conditions and compared with theory

On the theoretical side most of the problems of the behavior of electrons which are injected into the accelerator tube have been solved The effects of injection energy on the energy and intensity of the emergent beam and on the energy spectrum have been worked out Optimum injection energy can be computed for a given maximum r-f field in the cavity These computations have been based on the assumption of a wave traveling down the tube with the velocity of light, as will be the case for the tube being constructed It will also be possible to calculate the way in which the wave velocity should be varied if low injection energies are used

Physical Design of the Tube Mounting and Associated Equipment Preliminary design work has been finished on the tube mounting and the auxiliary apparatus (magnetrons vacuum system, modulators, etc) Actual construction awaits the availability of space for the apparatus In the meantime, orders have been placed for all of the main items needed Construction will begin as soon as the space is available

The largest piece of auxiliary apparatus is the Van de Graff generator which will be used to provide electron injection energies up to 2 Mev. The design of this generator is completed and it is now on order.

Miscellaneous Items. There are a number of additional studies proceeding which should be mentioned. Work is continuing on the characteristics of reentrant type cavities. This type of cavity will not be used in the first accelerator, but it is felt that the information will be of considerable interest. Some work has been done on the problem of mode suppression in iris cavities. Dimension-determining measurements have been made on iris cavities designed for a wave velocity less than the velocity of light. This latter information will be of great value if it is decided at any later date to use lower electron injection energies.

III. B ULTRASONICS RESEARCH PROGRAM

Staff Dr. C. Kittel
J. K. Galt
J. R. Pellam
R. A. Rapuano
W. Roth
Professor G. F. Squire, Low Temperature Group

Description of Project Radar pulse technique and microwave power sources are employed to study ultrasonic properties of solids, liquids, and gases. Some of the techniques applied are discussed in the Final Report of June 1946. The principal projects of the group are

1. Measurements of velocity and absorption of sound in liquefied gases including liquid helium at 15 Mc/sec and 45 Mc/sec
2. Absorption measurements at 200 Mc/sec
3. Absorption in solids at 1 to 100 Mc/sec
4. Paramagnetic relaxation experiments using ultrasonic waves at 15 Mc/sec
5. Attenuation in single crystals

Several reports by members of the group have been, or are about to be, published¹. The investigations mentioned above are now discussed in turn.

1 a Measurements in Liquid Argon

Status The last Quarterly Progress Report gave results for the velocity and absorption in liquid argon at 84°K and at 15 Mc/sec. The absorption value was found to be in the neighborhood of the value calculated from viscosity and heat conductivity. To obtain better accuracy of the absorption value, equipment has now been set up for measurements at 45 Mc (since absorption varies as the square of the frequency). Measurements are being made but results are not yet ready for publication.

1 b Measurements in Liquid Helium

Description of Project A cooperative program with the Low Temperature Group² is under way for determining the ultrasonic velocity and absorption in liquid He I and He II as functions of temperature.

1 See list of technical reports on page 2 of this report.

2 For other low temperature experiments see Section II D.

Acoustic gear designed to function within the helium liquifier makes possible the use of pulse techniques previously reported¹. The arrangement is shown in Fig 1. At the left the upper portion of the sound gear (A) may be seen protruding from the liquifier (B). The electronic gear, shown at the right of the picture, operates as follows. A trigger is generated by the A/R Radar Range Scope (C) simultaneously with the start of the sweep. This trigger sets off the pulse generator (D) which in turn drives the tunable oscillator-amplifier (E). The resulting r-f pulse passes through the electrical impedance-matching network (not visible in Fig 1) and into the sound gear (A). A 15-Mc/sec quartz crystal immersed in helium at the lower extremity of the sound gear transduces the electrical signal into an ultrasonic pulse.

Figure 2 is an interior view of this portion of the gear, and shows the crystal (G) which projects the pulse upward against the fused quartz reflector (H) also immersed in liquid helium. The returned echo is reconverted to an electrical pulse by (G). The position of the reflector with respect to the crystal may be controlled through a calibrated screw arrangement by means of the hand wheel (I) shown in Fig 1. Stirring is accomplished by means of the electric motor (L) and the stirrer (M).

The electrical r-f signal due to the echo passes through the impedance-matching network, encounters a series of attenuators (J) and thence arrives at the receiver (K). The resulting video pulse, applied to the range scope, provides the observable signal. Velocity is determined from the increased time delay introduced in the echo by an increased sonic path length. Absorption is determined by keeping the ultrasonic attenuation within the liquid helium compensated electrically, i. e., the echo signal strength is held constant as the reflector is moved.

The low density and low sound velocity in liquid helium together result in a very low characteristic acoustic impedance, causing narrow crystal bandwidth and increasing the difficulty of generating acoustic waves. The primary problem at present is to reduce signal fluctuations presumably caused by boiling, attributable either to heat conduction or acoustic energy. The total range of acoustic power available is limited by cavitation in the helium.

Thus far measurements have been made at 15 Mc/sec. The velocity results agree with values previously reported by investigators² using continuous-wave methods. Absorption coefficients measured above the λ -point (2.19°K) are in order-of-magnitude

1 J. R. Pellam and J. K. Galt "Ultrasonic Propagation in Liquids. I. Application of Pulse Technique to Velocity and Absorption Measurements at 15 Megacycles", RLE Technical Report No. 4, also published in J. Chem. Phys. 14, 608 (1946).

2 J. C. Findley, A. Pitt, H. Grayson Smith, and J. O. Wilhelm, Phys. Rev. 54, 506 (1938) 56, 122 (1939).

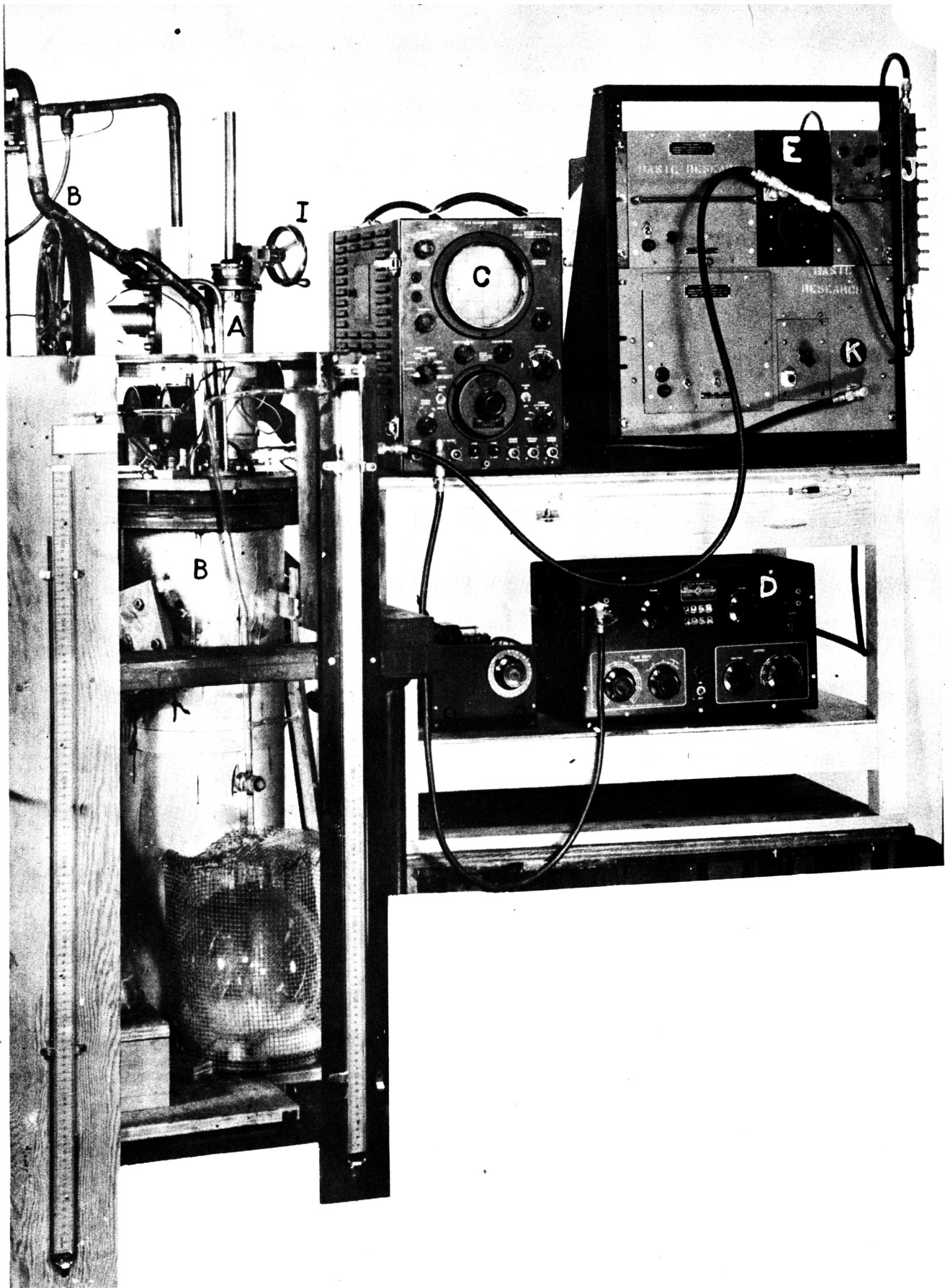

Figure 1. Low temperature and electronic gear. (A) sound gear, (B) helium liquefier, (C) radar range scope, (D) pulse generator, (E) oscillator-amplifier, (I) handwheel, (J) electrical attenuator, (K) receiver.

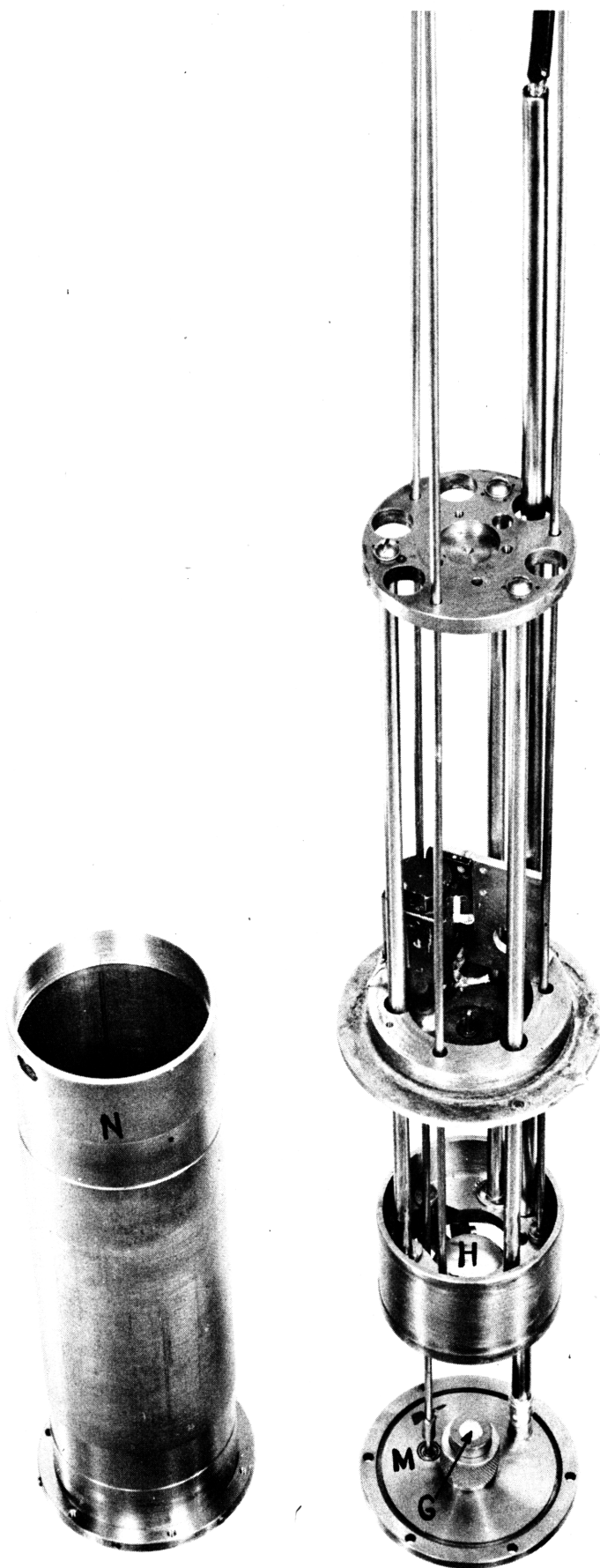

Figure 2. Transducer-reflector system (disassembled view).
(G) crystal, (H) fused quartz reflector,
(L) stirrer motor, (M) stirrer, (N) housing.

agreement with theoretically computed values based on viscous and thermal losses. A complete disappearance of the echo is observed in the immediate region of the λ -point. Least absorption occurs just below the λ -point, the absorption again increases as the temperature in He II is lowered (i.e. within the range thus far measured). The lowest temperature at which values have been obtained in these experiments is 1.77°K .

2. Absorption Measurements at 200 Mc/sec

Status A quartz crystal operated at a high harmonic has been used to set up in water ultrasonic waves of frequency 225 Mc. Crystal resonances have been measured and show quite a strong increase in sharpness with order of harmonic. A program of measurements over a wide band of frequencies is being planned and equipment is being constructed for this purpose.

3 Absorption in Solids

Status The main emphasis since the previous report has been on the design of receiving equipment to operate continuously throughout the 1-100 Mc/sec region in conjunction with the continuously variable carrier frequency pulse transmitter mentioned therein.

A review of possible receiving systems was made including such general types as crystal video and superheterodyne. The latter was selected on the basis of minimum detectable signal, ease of design, stability and convenience. In accordance with this choice, the tuning unit of an AN/APR-1 receiver which operates from 40 to 100 Mc/sec is being modified to cover the desired frequency range.

Before this work was attempted, an analysis of the complete loop (transmitter, transmitting quartz crystal, acoustic load, receiving crystal, the receiver, and in some cases, a transmit-receive switch) was made to determine the impedance relations leading to optimum performance. General equations were derived which are applicable to any case under consideration. The system might comprise, for example, (a) a single crystal for both transmitting and receiving with or without a transmit-receive (TR) switch; (b) two crystals, thus separating the transmit-receive functions; (c) an acoustic medium in which length of sample under test can be varied so that either single- or multiple-echo measurements may be made, (d) a fixed length acoustic medium with which either single- or multiple-echo techniques may be used.

A method for determining experimentally the loss upon reflection at the crystal boundaries has also been worked out. This has not yet been tried so that the accuracy is still not known. Knowledge of this loss permits correcting the experimentally determined attenuation in the sample for the reflection at the surfaces. The theory indicates that the equipment now under construction will be roughly 70 db more sensitive than existing equipment used for multiple-echo work.

4 Relaxation in Paramagnetic Salts

Status Equipment has been set up at 15 Mc/sec to observe the change in absorption to be expected in solutions of paramagnetic salts under a magnetic field. This consists of a bridge, one arm of which is a variable length acoustic delay line in series

with an attenuator (The tank used for the liquid measurements reported in RLE Technical Report No. 4 was slightly modified and serves as the variable delay line) The other arm is a fixed delay line placed between the poles of an electromagnet This second arm also has an attenuator in it A pulser excites both arms at one end and a receiver picks up the output from the other ends. The delay lines are filled with the solution to be investigated and with the magnetic field off, the attenuators and the length of the variable line are adjusted so that the signals from the two arms of the bridge almost cancel each other in the input to the receiver. Then when the magnetic field is turned on, the relaxation effect should produce a change in this difference signal

The substance for which the largest effect is expected at 15 Mc is $MnCl_2 \cdot 4H_2O$ A two-normal solution of this was used in these experiments and no effect was observed A more concentrated solution would produce a larger effect, but it would have too high an attenuation to transmit an adequate signal. The experimental arrangement was such that an effect 50 db below the signal transmitted through either arm of the bridge could be observed Calculations indicate that the effect was down 55 to 60 db Since the change in signal should be proportional to the square of the magnetic field, it is hoped that it will be possible to repeat the experiment with a larger magnet. The field used in this experiment was approximately 10,000 gauss

5 Attenuation in Single Crystals

Status Equipment is being set up to make measurements correlating slip in single crystals with sound attenuation The first work will be done in NaCl and Al Stresses can be produced in sound waves of the same order as that which causes slip in the static case in these materials The question then is whether this means that sound attenuation will be a function of crystallographic direction, at least at high sound pressure (or stress) amplitudes Arrangements are being made to obtain crystals, and high-powered pulsers are being constructed for the work at large signal amplitudes It should be mentioned that elastic constant measurements for these materials will also come out of this work This new method will thus provide a check on previous measurements and permit data on some new materials to be obtained

6 Review Paper on Ultrasonics

Dr C Kittel

At the invitation of the Physical Society of London, a comprehensive review has been written on ultrasonics research with particular reference to the properties of matter in the gaseous, liquid, and solid states The paper is to appear in "Reports on Progress in Physics"

In the course of preparing the review, several original calculations were made Of particular interest the Landau-Teller calculation¹ of the probability of

1 L Landau and E Teller Physik Zeits Sowjetunion 10 34 (1946)

transfer of vibrational and rotational energy in gases was refined considerably by use of the impact parameter method. A simple relation was derived between the transfer probability and the vibrational frequency of the molecule, the result is in qualitative agreement with a number of experimental findings.

III C HIGH SPEED OSCILLOSCOPE AND HIGH VOLTAGE PULSE-MEASURING TECHNIQUES

Staff O T Fundingsland
L A Harris
D F Winter

Description of Project The construction of two fast sweep synchrosopes capable of measuring time intervals of 10^{-9} sec on single pulses has been completed. Component circuits have been tested in both units and found to meet design specifications. The first unit has been successfully used for about 100 hours in several experiments including measurement of rapidly rising voltage pulses applied to a 3-cm magnetron load, and random noise generation in a 30-Mc/sec amplifier (designed by G E Duvall).

Status Measurements of the input impedance of ten cathode-ray tubes, type K1017, have been made at 150 Mc/sec. The impedance was found to be capacitive and equivalent to from 4 to 4.5 μ f. Measurements were also taken at 3000 Mc/sec, but at this frequency there was no consistency in impedance from tube to tube. This project has now been concluded and a detailed final report on it is in preparation (RLM Technical Report No. 27).

D DEVELOPMENT OF FLASH TUBE

Staff Professor H E Edgerton
B F Logan, Jr

Description of Project Precision methods are being developed for measuring light and electrical characteristics of the electric flash tube as used by the Air Forces for night reconnaissance.

The program contemplates a careful study of overload characteristics of the tube. The object of these tests is to determine light-producing efficiency and the fundamental physics of the flash tube so that a more efficient and useful form may be developed.

Status By using an A/R ranging scope, oscillograms are being made of light intensity and current as a function of time during the discharge. A photoelectric tube working into a cathode-follower circuit is used to feed a voltage proportional to light intensity into the scope. The sweep is synchronized to trip when an ionizing-voltage pulse is applied to the flash tube. Thus the oscillograms record the ionization time of the tube.

A suitable network is being prepared to record the tube voltage as a function of time during the discharge.

Staff J N Thurston
P L Richman

Review of Previous Work The Final Report of June 30, 1946 and the last Quarterly Progress Report have dealt with the progress made in the preliminary development of certain compact electronic units that are designed around subminiature tubes similar to those used in the proximity fuse. Some of the reasons for the development of such units are listed below

a Ease and speed in design and construction of complex circuits. All units to date have been constructed on an octal base so that they fit a standard octal socket

b Standardization of performance of the packaged unit

c Ease and speed of replacement of functional units in case of failure

d Decreased parts and labor cost in apparatus assembly

The units developed prior to the period covered by this report are

a D-c Amplifier No 1. This is a four-tube unit with cathode-follower output. The first stage is a parallel-balanced amplifier, with the circuit arranged to permit the subtraction of two independent inputs. No feedback is employed.

b D-c Amplifier No 2. This unit, which also employs four tubes, is similar to D-c Amplifier No 1 except that a second differential amplifier is used instead of the cathode-follower output stage. The operation of this unit is discussed in some detail later.

c A-c Amplifier No 1. This is a three-tube amplifier with cathode-follower output. Negative feedback is employed to reduce the voltage gain from about 4000 to a standard value of 1000.

d A-c Amplifier No 2. This utilizes two pentodes instead of triodes, but has a triode cathode-follower output stage. Here the voltage gain without feedback of approximately 10,000 is reduced to 1000 by adjustment of the feedback network. This circuit, which now practically supersedes A-c Amplifier No 1, has been adapted for tentative commercial production by Sylvania Electric Products Company.

e Multivibrator Frequency Divider No 1. This unit, which employs three tubes, was designed to provide convenient means of obtaining timing pulses at frequencies of 20, 10, 5, 1, and 1/5 cps.

e Units Developed and Tested 1 Direct-Coupled Amplifiers. As was described in some detail in the last Progress Report, a second design of the differential-input direct-coupled package unit amplifier was devised (see Fig 1) employing two pentode stages of differential amplification and having a relatively high output impedance (about 35K). The entire package is the left-hand unit in Fig 2. This unit achieved an improvement over the previous design in that it was much less subject to fluctuations in the negative supply. These were introduced previously at the grid of the second stage, the first stage contributing but one one-hundredth of the amplification of the whole unit. This improvement is secured at the expense of sensitivity of

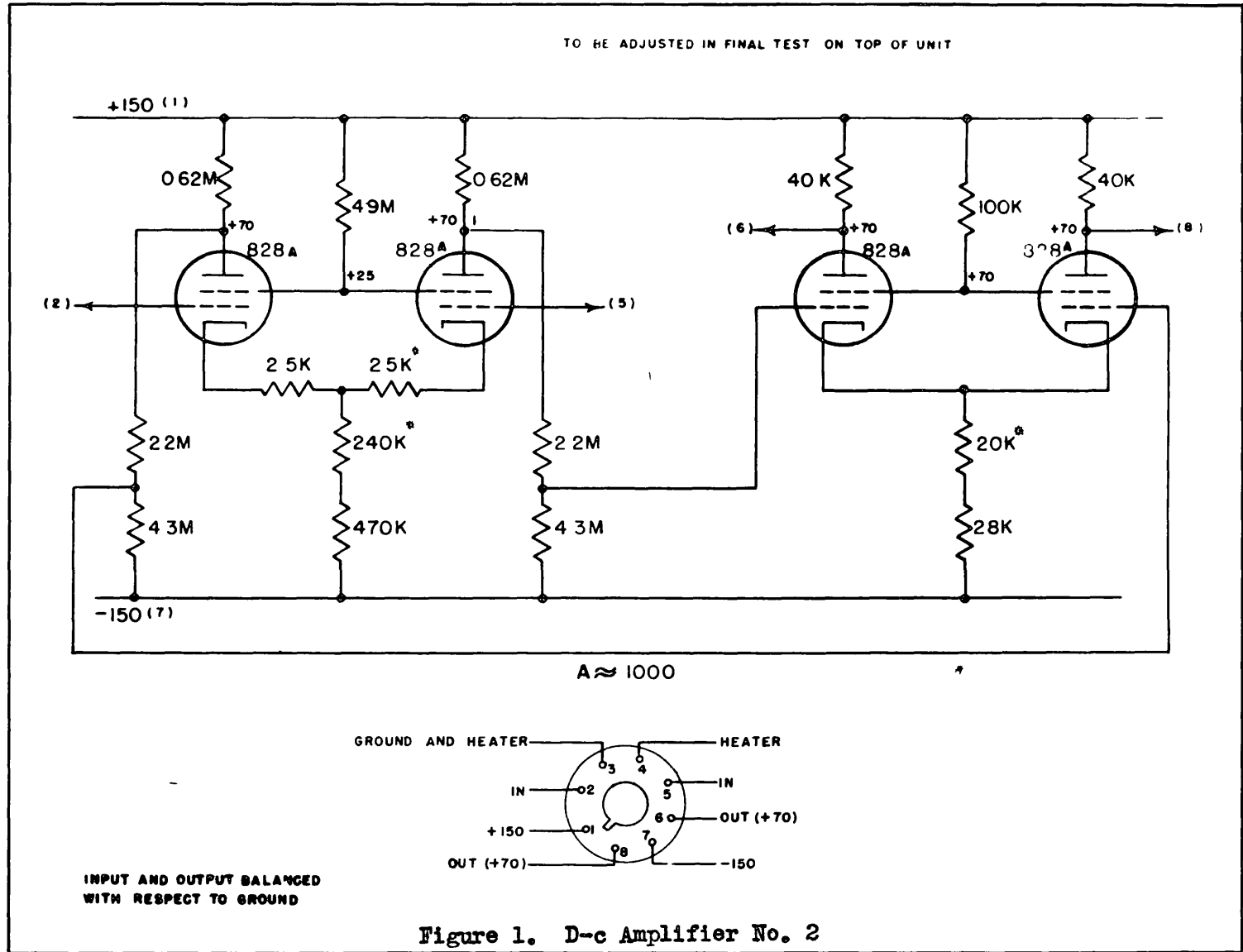

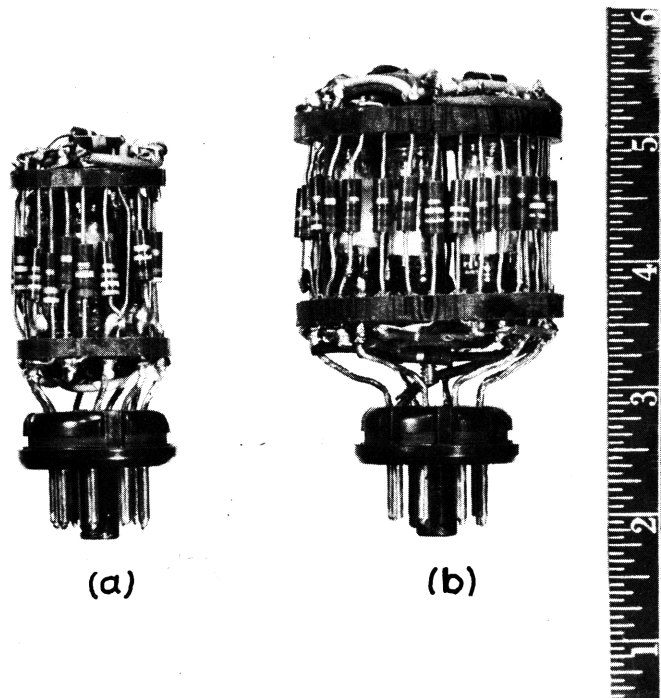

Figure 2. (a) D-c Amplifier No. 2
 (b) D-c Amplifier No. 3.

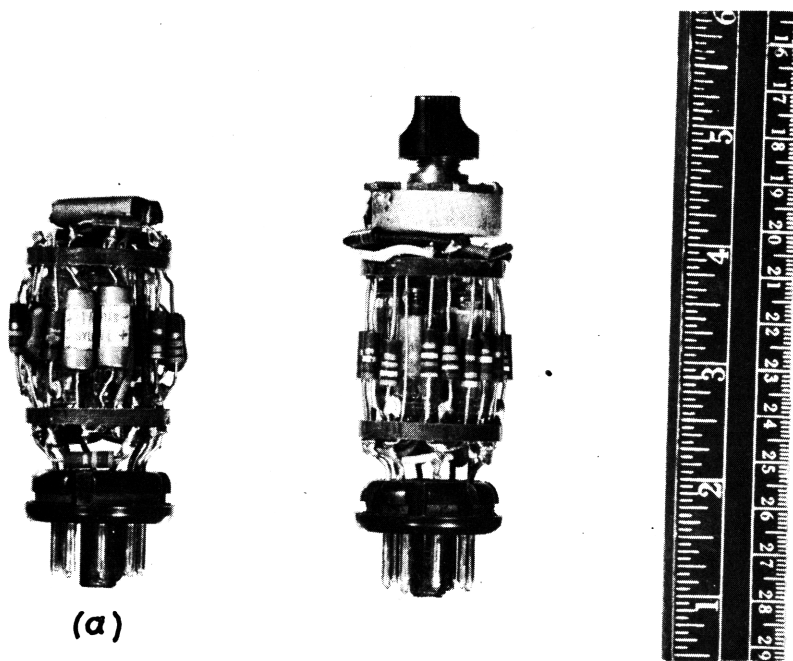

Figure 3. (a) Square-wave Generator No. 1
 (b) D-c Amplifier No. 2 with
 incorporated potentiometer.

input grid balance, which is much greater with the new unit since the balance of the second stage depends on $|A|$ times the balance of the first stage where $|A|$ is the gain of the first stage. It is found that for an output-plate voltage difference of about 20 volts, the gain of the unit is reduced by 30-40 per cent. This is a serious disadvantage since it implies constant check of the output plates of each unit during the first few hundred hours of service. The gain of the unit is roughly 1000-1200, and input grid current is usually less than $0.005 \mu\text{a}$ with a noise level of 10-15 μv for a 10-kc bandwidth. The maximum differential formation (signal common to both input grids that will be just indistinguishable above the noise) averages about 1 mv for various units of this design which have been constructed. If balancing the tubes of the first stage with a suitable resistor network is accomplished, this figure may be increased to roughly 15 mv, corresponding to a crosstalk rejection or differential formation of about one part in 1000.

Crosstalk rejection is an important feature of the differential amplifier which makes it suitable for use in applications wherein a voltage common to both grids - often larger than the signal - must be cancelled in order that the signal appear significant. It is expected that a differential amplifier unit capable of rejecting better than one part in 1000 will be packaged in the near future.

Drift tests on D-c Amplifier No. 2 give an average value for drift of about 2 mv/hr, with a flicker of approximately the same order of magnitude. (See Fig. 4 for representative drift test as recorded on an Esterline-Angus recording milliammeter. Scales are 15 min/div and 2 mv/div. Drift is about 1 mv/hr in this particular run while flicker averages about 2 mv.) A test unit of this amplifier incorporating a potentiometer appears on the right in Fig. 3.

In order to overcome the difficulties of (a) extreme sensitivity of gain to output plate balance, (b) sensitivity of unit to tube ageing, (c) high output impedance, (d) sensitivity of output plate voltage balance to input grid bias, a direct-coupled amplifier was designed as an eight-tube unit, -- a radical departure from the four-tube and three-tube units designed and employed until now. There is still some doubt as to the practicability of employing more than four or five tubes in a single package, but the advantages of doing so for the direct-coupled amplifier seemed to warrant a trial. Subsequent use of the new unit in measurement applications (one of which is described later) offers some justification for the step. The diagram for the amplifier appears in Fig. 5 and the unit as it looks when assembled is shown on the right-hand side of Fig. 2, next to its four-tube predecessor.

This latest direct-coupled amplifier has differential action in the first three stages, with separate cathode-follower outputs in order to facilitate closing the feedback loop, as well as to secure low output impedance when desirable. The first stage employs triodes (SD-917a) for two reasons: first so that the first stage gain will be relatively low and second in order to better the differential formation which improves by a factor of two or three when triodes are substituted for pentodes. The second and third stages afford the principal gain of the unit.

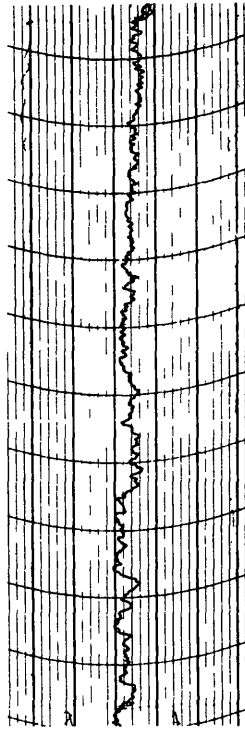

Figure 4 Representative drift test on D-c Amplifier No 2 as recorded on Esterline-Angus milliammeter Scales are 15 min/div and 2 mv/div

The open loop gain is about 2500 to 3000, which may be cut back to any desired value (about 400 is advised in order to secure reasonable stability) by introducing feedback in the differential mode, closing the loops through the current-carrying tubes as shown on the diagram. As a result of this feedback, it is possible to unbalance the output by 20 volts or so with only a small percentage reduction in gain.

Provision is made for μ -balance in order to optimize the differential formation (the 5M resistors in the first stage). Gain balance may be secured in applications where it is necessary by means of adjusting the feedback resistors.

Microphonics, grid current noise, drift and flicker are all about the same for the D-c Amplifier No 3 as for the D-c Amplifier No 2.

2 Square-wave Generator The square-wave generator designed and constructed in packaged form is only one of many possible types of such generators, and was selected because it affords a demonstration of several techniques peculiarly adaptable to sub-miniature package assemblies.

The Germanium crystal diode is a relatively new feature in electronic circuits,^{1,2} and finds application as a substitute for vacuum diodes where a very large

1 B. Chance, "Some Precision Circuit Techniques Used in Wave-form Generation and Time Measurement", RSI 17, 396 (1946).

2 W E Stephens, "Crystal Rectifiers", Electronics 19, 112 (1946)

-72-

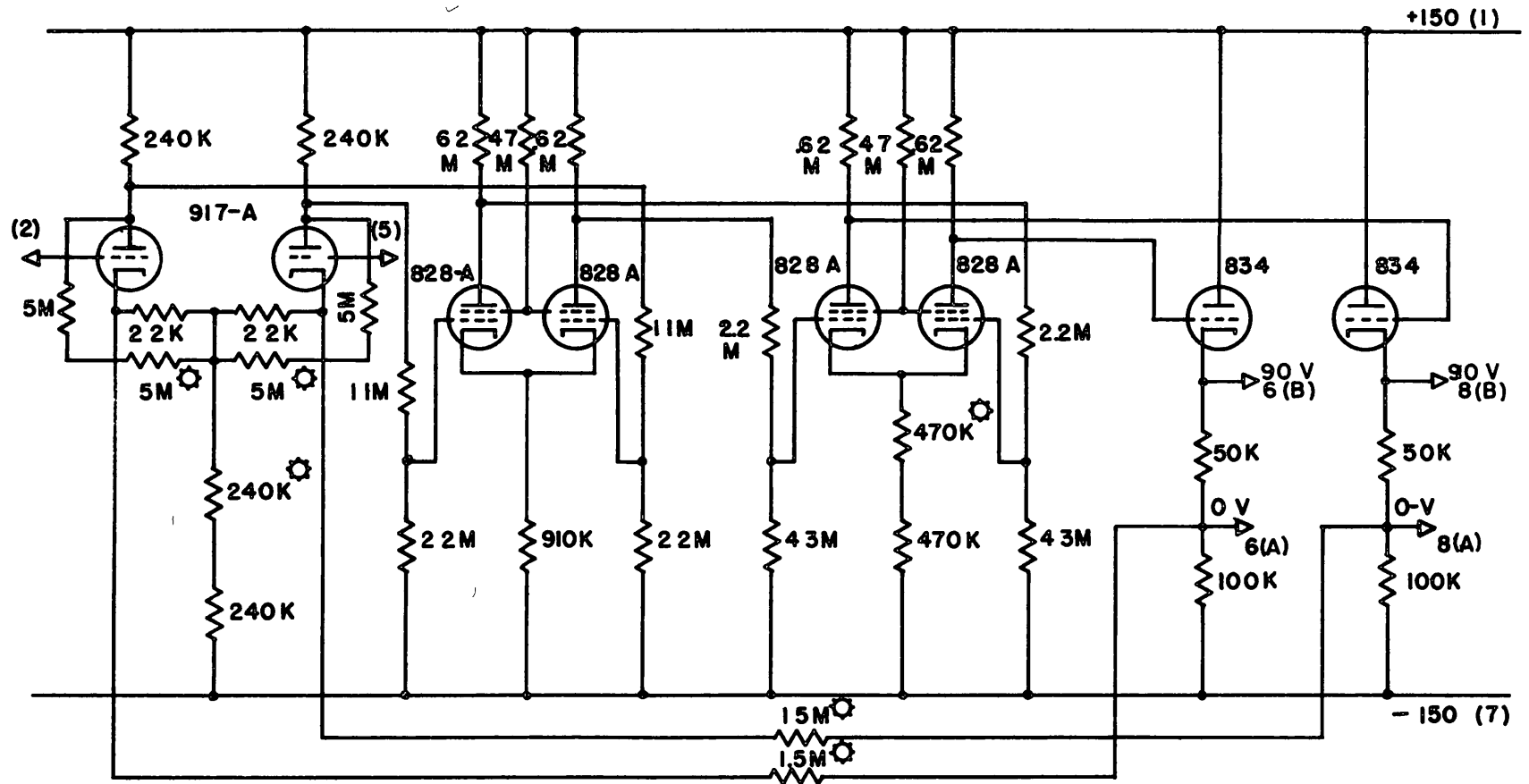

⊗ SIGNIFIES (ADJUST TO SPECIFIED PERFORMANCE)
 OPEN-LOOP GAIN \sim 2500
 CLOSED-LOOP GAIN \sim 250-500

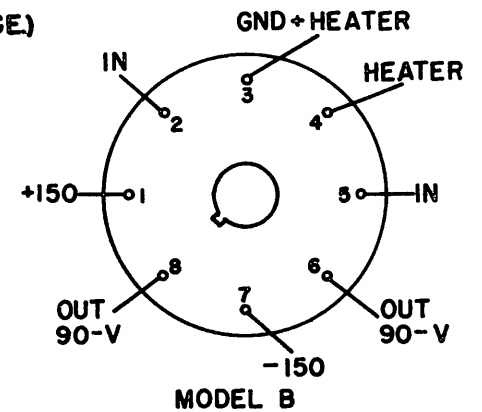
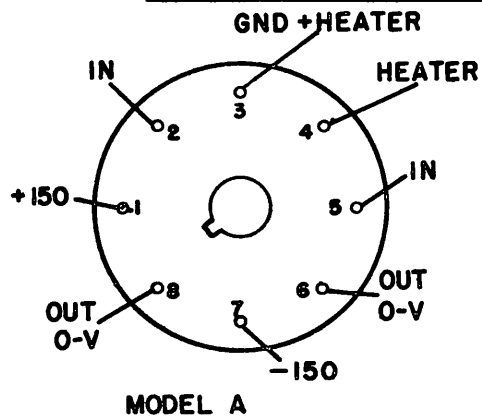

Figure 5 D-c Amplifier No 3

reverse resistance is not required. The advantage of the crystal diode in package assemblies is its small size and the fact that it has, of course, no filament dissipation. The diagram of the square-wave generator appears in Fig 6. The coupling capacitor is fairly large electrically (0 μ f) but is of the "hearing-aid" or miniature variety and hence is physically quite small. The entire unit is pictured in the left-hand side of Fig 3, showing the two Ge diodes (two are employed in series to effect a higher reverse resistance) in the main body of the assembly and the 0 μ f miniature coupling capacitor on the top.

3 R-C Oscillator-amplifier No. 1 Many control and measurement devices require as a vital part of them a self-contained oscillator. A package R-C oscillator-amplifier unit that utilizes the circuit of Fig 7 was developed to fill such a need. The circuit is a cathode-coupled type, the frequency of which is determined by the constants of the ladder network shown between the second and third tubes. The output voltage from the second cathode follower is approximately 10 volts rms, when good sinusoidal waveform is obtained. The frequency range can be extended above or below the frequency at which the circuit normally oscillates (about 300 cps) by means of external shunt resistors or capacitors. Terminals 2, 3, and 4 are provided at the socket for this purpose.

When the circuit is used as an oscillator, terminal 5 should be grounded. If this terminal is connected to an external signal instead, the circuit can be used as an amplifier of adjustable selectivity. The selectivity is controlled by the resistor used above to modify the waveform of the oscillator output. The frequency is controlled just as it was for the circuit when used as an oscillator. As indicated on the diagram, both the selectivity and frequency adjustments can be made externally as before.

4 Voltage Stabilizers Work has begun and is almost completed on miniature stabilizer units with stabilized output voltages of plus and minus 150 volts, suitable for use with previously constructed assemblies using these supply voltages. These units incorporate potentiometers for accurate adjustment, and employ a single stage direct-coupled amplifier to provide amplification of the error signal. The circuit diagram for the -150-volt stabilizer appears in Fig 8. The +150-volt stabilizer is still in developmental stages.

5 Null-indicating Gain Meter Employing Package Unit Techniques As an aid in the work with package unit amplifiers, both a-c and d-c, and as a demonstration of package unit techniques as applied to measurement problems, a gain meter was designed so that mid-band gains and frequency responses of the units already constructed, and any units which might be constructed in the future, might be measured accurately, rapidly, easily, and independently of the phasing of the output and input signals. In its final form, the meter is a direct-reading instrument in the region of the null condition. The circuit diagram of the meter appears in Fig 9 wherein package units are represented schematically. The meter is simply a calibrated attenuator with a means for comparing the attenuated-amplified signal with itself. When the null balance is secured, the gain of the amplifier unit in question is given by

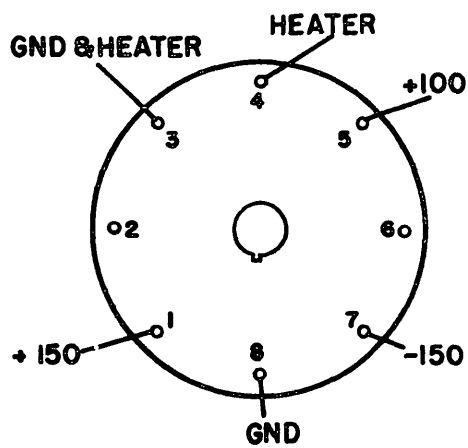
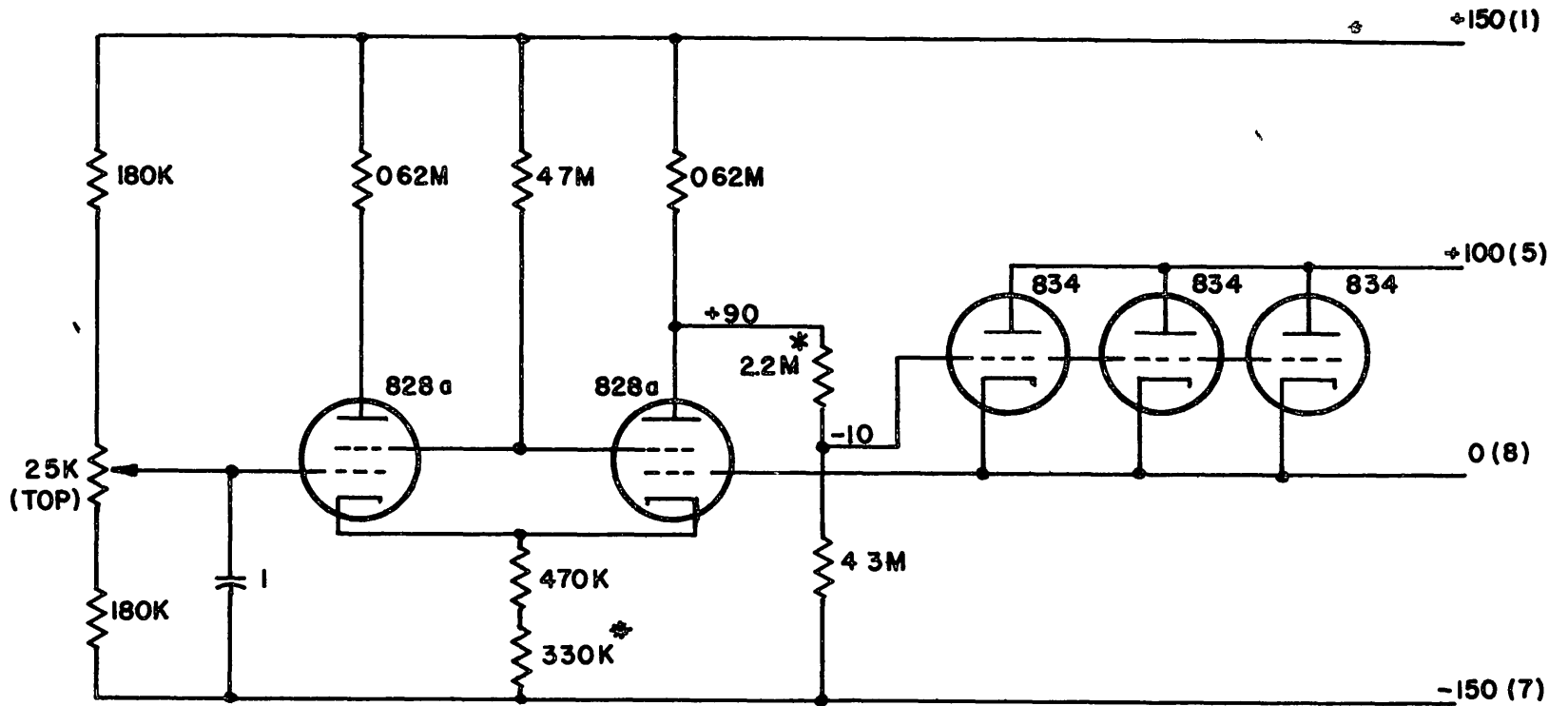

* SIGNIFIES ADJUST TO SPECIFIED PERFORMANCE
25 MILS OUTPUT AT -150V

Figure 8. B-Supply Stabilizer

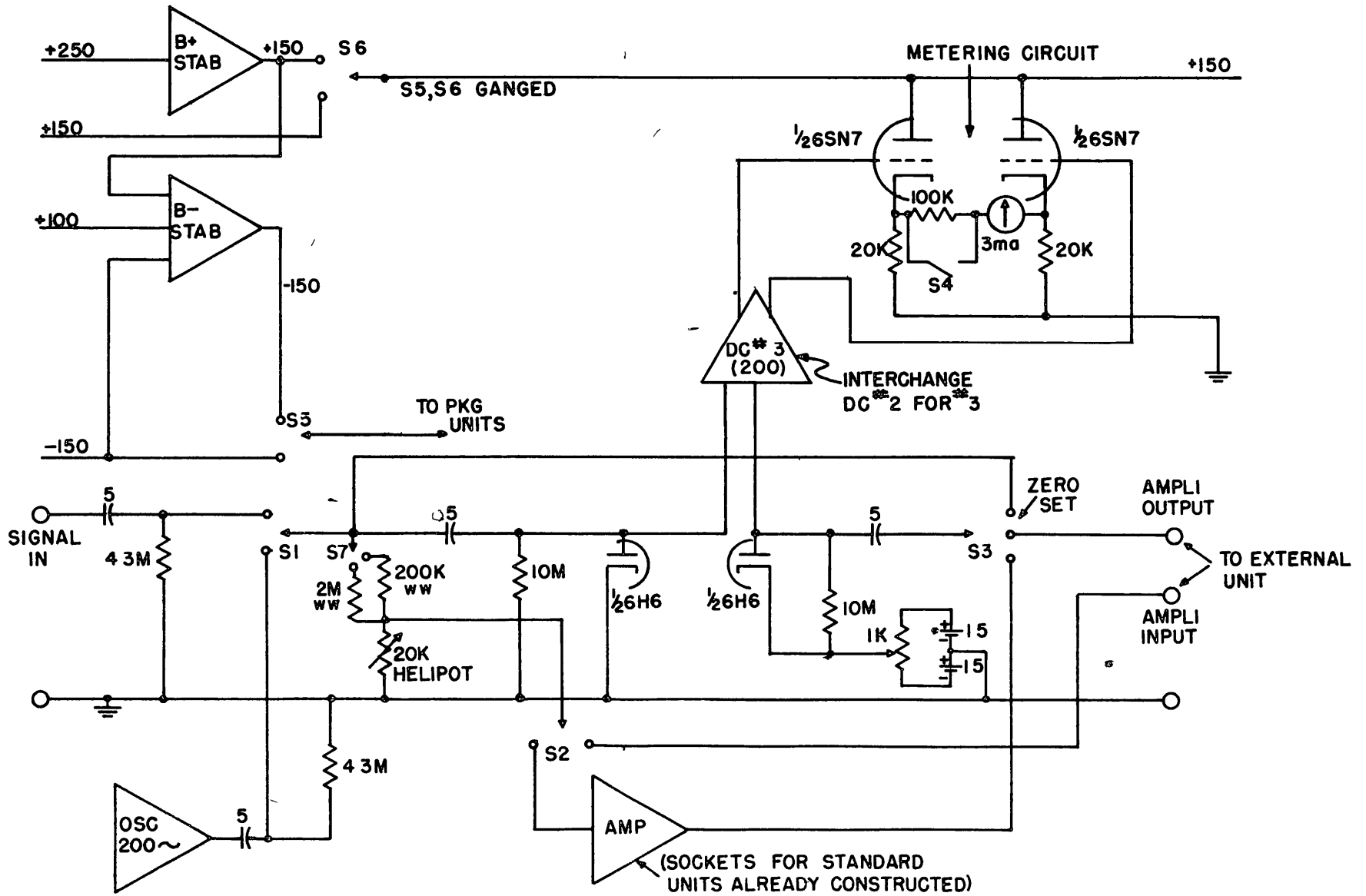

Figure 9. Null-indicating Gain Meter

200K or 2M divided by the value of the 20K helipot, plus unity. Sockets equipped to handle already constructed amplifiers are incorporated in the meter, and arrangements are made for measuring mid-band gain - which often is all that is desired - by means of a package-unit oscillator previously described. Means are also provided for the inclusion of the package-unit stabilizers - both plus and minus 150 volts - in the unit, so that the meter may be as independent of external equipment as possible.

The meter as designed measures a range of gains from 10 to about 5000. In the region of null balance, maintaining the amplitude of the signal fixed while changing its frequency causes the meter to give a direct reading of the change in gain of the amplifier under test. For this reason the instrument is adaptable for the recording of gain drift or variations. A special dial is employed on the 20K helipot in order to secure a high degree of accuracy in the gain calibration.

F CYCLOTRON R-F DESIGN

Staff Professor G G Harvey
T Moreno
M Plotkin Brookhaven National Laboratories

Description of Project. The purpose of this project is to investigate the design of r-f resonant circuits suitable for large, frequency-modulated cyclotrons. A variety of circuits has been proposed; the most promising will be more carefully analyzed, and experimental investigations conducted with the use of scale models at higher frequencies.

The immediate object of the investigation is to design a resonant circuit for use with the 600-Mev proton cyclotron to be constructed at Brookhaven National Laboratories. The magnet poles of this cyclotron will be twenty feet in diameter, and the operation frequency will be modulated over a range of 26 to 13 Mc/sec. It is most feasible at present to accomplish this frequency modulation with the use of a mechanically rotating condenser, giving a modulation frequency of 120 cycles.

The large physical dimensions preclude the use of dee structures, such as are found in smaller, conventional cyclotrons. Cavity resonator techniques as developed at much higher frequencies are, however, applicable.

Status A one-fifth scale model of one proposed resonator design has been constructed. Experimental checks of modes, tuning, and Q are being made and will be compared with the calculated values. This resonator is essentially a quarter-wave section of flattened coaxial line, short-circuited at one end and open-circuited at the other. The protons will be accelerated by the voltage developed across the open end of the resonator, and the frequency modulation accomplished by a pair of mechanically rotating condensers at the open end.

III G TEN-CM SWEEP-FREQUENCY OSCILLATOR

Staff Professor J B Wiesner
H M Bollinger

Description of Project In the development of the microwave sweep-frequency oscillator to be used in the measuring of component characteristics the problem of broad-banding the detectors and directional coupler has been considered

Status Load impedance of the bolometer detector has been determined experimentally as a function of frequency Investigation showed that load impedance is also somewhat dependent upon bolometer power level the impedance vs frequency characteristics were taken at a relatively high power level, and at this level the power reflected from the bolometer mount, due to mismatch, never exceeded 0.15 db over a 10 per cent bandwidth Taking similar data at the actual operating level of the bolometer is difficult, as standing-wave ratio measurements at such a low level require a large probe depth which introduces error into the readings Such error is not believed to be greatly significant in this case and it has been assumed that the bolometer reflects less than about 0.25 db over a 10 per cent bandwidth at the actual operating power level Determination of similar frequency-response characteristics of the thermistor mount used to measure the main generator output showed an extreme dependency on power level Because of this the thermistor has been abandoned, and an additional broadband bolometer is in process of construction in the machine shop

The problem of obtaining reasonably broadbanded detectors having been dealt with attention has been shifted to the coupling characteristics of the directional coupler used to sample the generator output power For accurate sampling it is essential that the coupling coefficient be as frequency insensitive as possible Measurements indicated a total variation of 0.5 db over the 10 per cent bandwidth, and these agreed within 0.25 db with theoretical calculations of frequency sensitivity Although not so important as coupling characteristics directivity measurements have been made over the 10 per cent bandwidth As expected there is a rather large variation with frequency from 33 db at the high frequency end to 21 db at the low frequency end

H THREE-CM SWEEP-FREQUENCY OSCILLATOR

Staff R M Fano
R B Adler

Description of Project For the investigation and alignment of microwave filters, it is desirable that a relatively wide-band sweep oscillator be made available The range of the sweep should cover approximately a 10 per cent band, and the rate of sweep should be rapid enough to permit observation of the response on an oscilloscope Although work is already being done on a 10-cm oscillator, the 3-cm application presents certain new features requiring separate investigation

Status The Western Electric 2K49 tunable reflex oscillator furnishes the only presently available 3-cm model of this type of tube with an external cavity The

design of an appropriate cavity for this application has been carried out, but final performance data on the oscillator are not yet available. Preliminary tests have indicated that although the tube oscillates satisfactorily at about 3 cm, some revision of the coupling method is required to obtain sufficient output power.

A rotatable vane which is expected to vary the frequency of the oscillator over the desired range is now under construction. No tests can be carried out until the vane and drive-motor assembly are completed because of the small size of the cavity and the consequent close tolerances required in the alignment of the vane.

The need for a broadband directional coupler led to consideration of a special type described in Sperry Report No. 5224-1061 (by T. Moreno), which should give a coupling constant of 20 ± 10 db over the band. Design of such a directional coupler is in progress.

The design of the reflector control circuit to work in conjunction with the available 1200-volt supply has been carried out, but construction will not be undertaken until more data on the operation of the tube are available.