

VIII. COMMUNICATIONS RESEARCH

As reported in detail in the last progress report, the work in the Communication Group may be considered in two parts, the first containing a group of independent researches on technique and equipment, as for example, the work on FM multipath phenomena, and the second, a somewhat coordinated series of investigations encompassing noise theory, information theory, and statistical design of systems.

A. PULSE MODULATION STUDIES

Staff: E. R. Kretzmer

The present study of the interference problem in certain types of pulse modulation was first outlined in the Progress Report of October 15, 1947. Some of the basic phenomena resulting from interference between two pulsed carriers were discussed and illustrated in the last progress report.

The work has continued, with emphasis on experimental analyses of common and adjacent channel interference; although this has been done by means of a pulse-duration modulation system, many of the results are applicable also to pulse-position modulation or more generally to any type of pulse modulation which involves only time modulation of the pulse edges. Theoretical considerations have accompanied much of the experimental work.

The following items have been covered:

- (1) A mathematical derivation has been made of the time shift suffered by a desired-signal pulse edge as a result of interference. This has been expressed as a function of the phase difference between carriers and of the ratio of their amplitudes. Linearly rising and falling pulse edges were assumed. From this, the average effective noise time shift has been evaluated, based on the random nature of the phase difference between carriers. The results have been modified to apply to the exponentially shaped pulse edges and take into account the slicing level used in detecting the time position of the pulse edges.
- (2) A qualitative theoretical analysis has been carried out with the object of predicting the types of disturbances resulting from interference under various conditions. Common and adjacent channel as well as two-path interference were considered.
- (3) An experimental investigation has been made of the character of the semi-random noise that results from common or adjacent channel interference, when the interference ratio is less than one-half. The study was made by photographing cathode-ray traces and making noise-power measurements.

Following are the characteristics considered:

- (a) Crest factor.
- (b) Relation between actual noise output and pulse-edge noise time shift.

- (c) Some rough consideration of the noise spectrum.
- (d) Dependence of (a), (b), and (c) on the output low-pass filter bandwidth.
- (e) The effect of detector slicing level on certain characteristics of the noise.

(4) Experimental measurements have been performed of rms noise voltage resulting from interference, as a function of the following variables:

- (a) The interference ratio.
- (b) The direction of the desired pulses.
- (c) The duration of the interfering pulses.
- (d) The difference between carrier frequencies (the interference ratio being held constant at the detector).

Mathematical work has been commenced in order to check the curves obtained from these measurements.

(5) A single-channel pulse-position modulation system, to be used for interference tests, has been designed and partially constructed and tested. The two transmitters are capable of either small or large pulse-position deviations, and they can be switched to either pulsed-oscillator or pulsed-amplifier operation. The receiver obtains its timing information from the modulated pulses so that the system can operate without synchronizing pulses.

(6) The experimental investigation of the pulse-position demodulator first mentioned in the Progress Report of October 15, 1947 has been completed. This demodulator converts the position-modulated pulses into long flat-topped, amplitude-modulated pulses ("box cars"), such as were analyzed in RLE Technical Report No. 12. It has been found entirely practical and in certain respects superior to other types.

B. MULTIPATH TRANSMISSION

Staff: Professor L. B. Arguimbau
 L. Dolansky
 J. Granlund
 W. L. Hatton
 C. F. Hobbs
 H. D. Field

Speech and Music. In the last report it was noted that a new receiver is under construction to approximate the characteristics assumed in the calculations. Progress on this has been slow. The main difficulty at the moment is in the construction of a discriminator with proper bandwidth and decay time.

As a separate project an attempt is being made to apply wideband principles to the Bradley¹ detector circuit. Early results look promising.

1. W. E. Bradley, "Single-Stage FM Detector", Electronics, p. 88, October 1946.

Television. A video amplifier for use with a type A/R oscilloscope for checking waveforms has been completed. Under construction as an undergraduate thesis is a fast-sweep generator for use in conjunction with the amplifier.

A 200-Mc amplitude-modulated transmitter delivering about 100 mw has been constructed, and a video modulator for it will be made. Three stages are used in the transmitter so that there will be very little incidental frequency modulation.

Preliminary parallel work on a frequency-modulated transmitter is being started.

C. MICROWAVE MODULATION TECHNIQUES

Staff: L. D. Smullin
W. Coffey

Current practice in microwave repeater systems is to impress the information signal (television, etc.) upon a "sub-carrier" by standard modulation techniques that can be made quite linear. For instance, a 5-Mc/sec television signal is impressed on a (60-100)-Mc/sec "sub-carrier" at the first link station. This modulated high frequency is in turn impressed on the microwave carrier by some modulation scheme. In this way non-linearities of the microwave modulation produce harmonics of the "sub-carrier", and there is no distortion produced within the sideband which is to be amplified and radiated. Figure VIII-1 illustrates the various steps.

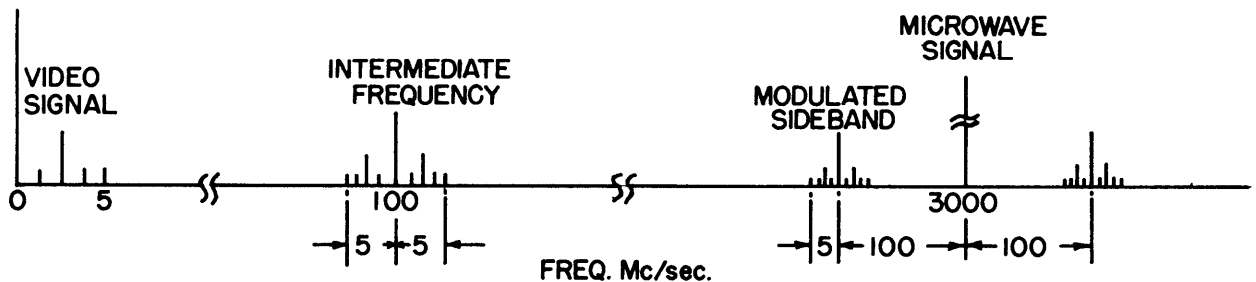

Figure VIII-1. Microwave modulation system.

One of the sidebands of the microwave output is filtered out, amplified if necessary, and radiated to the next station. At that point the signal is detected, beat down to about 100 Mc/sec, amplified, and shifted back up to microwave frequencies, etc. Thus the actual low-frequency signal is handled only once at the beginning and once at the end of the link.

It is obvious from the foregoing that an essential element in such a system is a method of wide-band modulation of a microwave carrier. A reflex klystron, frequency-modulated by the repeller voltage, will permit

swings of only about ± 10 to 20 Mc/sec. If this is done at a rate of 100 Mc/sec, the available sideband power will be about 5 per cent of the carrier power. Thus, a 1-watt klystron might produce 50 mw of useful sideband power. Since the sidebands are about 100 Mc/sec from the carrier, filtering out the carrier would not be very difficult.

One might also wish to use amplitude modulation produced in some non-linear impedance such as a diode or a crystal rectifier. Ordinary crystals (1N21B, etc.) have very small power-handling abilities because of their limited range of back-voltage operation. Germanium high-voltage crystals are presumably not very good at microwave frequencies. Some high back-voltage silicon crystals useful at microwaves have been produced by the University of Pennsylvania group. It is hoped that these may be developed into useful high-level modulation crystals.

The current experimental program is concerned with obtaining a more or less detailed knowledge of the modulation capabilities of conventional crystals, and of the high back-voltage crystals which are being produced for us by Sylvania Electric Products Co. from silicon furnished by the University of Pennsylvania group. Figure VIII-2 is a typical set of curves for a 1N21B crystal in which the square root of the power in one sideband is plotted against low-frequency (5 Mc/sec) modulating voltage for various values of carrier power absorbed by the crystal.

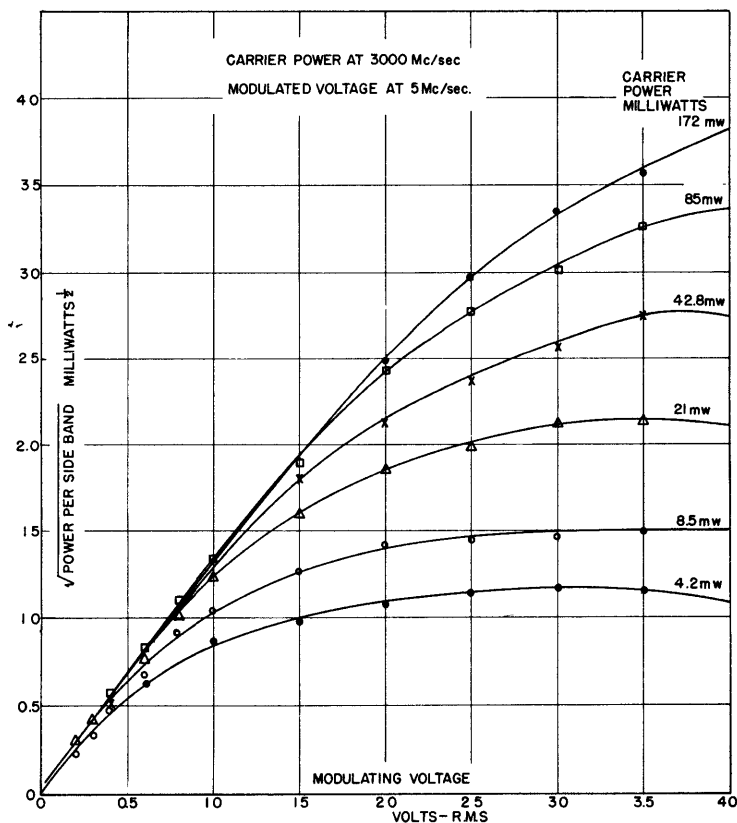

Fig. VIII-2. 1N21B silicon crystal as absorption modulator.

VIII. D. COMMUNICATIONS AND NOISE THEORY

1. Autocorrelation Function: Electronic Correlator

Staff: Professor Y. W. Lee
Professor J. B. Wiesner
T. P. Cheatham
E. R. Kretzmer

The synthesis of the optimum linear network for the various operations of filtering, predicting, differentiating, etc., is based largely upon the statistical characteristics of the time functions upon which we are to operate. It has been shown by Wiener that one of the most basic characteristics of a stationary time series is its autocorrelation function, mathematically defined as:

$$\varphi_{11}(\tau) = \lim_{T \rightarrow \infty} \frac{1}{2T} \int_{-T}^T f_1(t) f_1(t + \tau) dt .$$

Wiener has shown that the Fourier transform of the autocorrelation function is the power spectrum of the actual ensemble of messages which we wish to operate.

It is extremely important that a means be devised that will accurately and efficiently determine the autocorrelation function of any arbitrary stationary time series (for example : general or special types of speech, music, and noise).

Considerable thought has been given to various means of electronically performing autocorrelation (and cross-correlation) upon a desired random time function. Complicated methods involving storage of samples of $f(t)$ by means of magnetic tapes, special tubes, etc. have been temporarily discarded in favor of what appears to be a much simpler method involving pulse-sampling technique and multiplication in time-amplitude coordinates.

The design and construction of such an electronic correlator has been completed. The testing and modification of the circuits are now under way and progressing satisfactorily, with approximately two-thirds of the circuits operating within reasonable tolerances.

2. Optimum Prediction

Staff: Professor Y. W. Lee
R. Cohen

Trial calculations have led to the result that very poor prediction may be expected unless the autocorrelation curve $\varphi_{11}(\tau)$ is very closely approximated around zero. Both the slope and the radius of curvature of the autocorrelation are significant at zero and must be reproduced by the approximating function. Incidentally, the autocorrelation of any physical

function, having finite derivatives, must present a downward curvature at zero.

A study of the Wiener error of prediction has shown that if one plots $2[\phi_{11}(0) - \phi_{11}(\alpha)]$ vs. the prediction time α , the error starts tangent to this curve at zero (Fig. VIII-3), and goes asymptotically to $\phi_{11}(0)$.

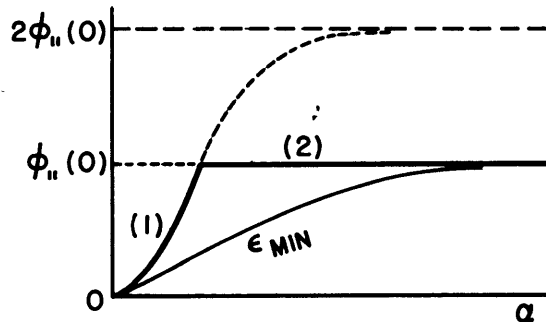

Fig. VIII-3.

Portion (1) of the curve $2[\phi_{11}(0) - \phi_{11}(\alpha)]$ represents the error that would be obtained under open-circuit conditions; portion (2) represents error under short-circuit conditions.

3. Random Noise

Staff: Professor Y. W. Lee
 Professor J. B. Wiesner
 T. P. Cheatham
 W. B. Davenport, Jr.
 L. Bressack

Since the last progress report, it has been decided that photographic techniques of obtaining statistical data are too slow and inefficient for determining many of the statistical characteristics desired. Attention has been directed toward electronic, and where possible, automatic methods of obtaining such data. It has been recognized that in determining a distribution function for the envelope, or instantaneous values, of a time function on a straight sampling and recording basis (i.e. time constant) that the range of possible error for each experimentally determined point on the distribution function will not be constant and will of course increase with decreasing values of the distribution function. If, however, the number of samples taken at each amplitude level is kept constant and time is made the variable, a distribution function will be obtained that has a percentage range of possible error that is the same for each point of the distribution function.

Equipment has been designed and constructed for determining the amplitude distribution of the envelope of random noise when viewed through a bandpass filter of variable bandwidth centered at 20 kc. The previous

center frequency of 400 cycles has been discarded in order to avoid as nearly as possible the effects of microphonics, flicker, and 60-cycle hum.

Data so far obtained on the amplitude distributions of random noise through a bandpass filter have been quite interesting in that they differed to a considerable extent from the theoretically expected values. These data have been insufficient for drawing any conclusions.

The conditions of the original experiment leave some question as to the degree of isolation of the experiment from outside and non-calculated sources. A second set of experiments is to be performed under much more carefully controlled conditions.

4. Amplitude Probability Distributions

Staff: D. F. Winter

The percentage of time spent by a stationary time signal in a given incremental amplitude is related to the probability distribution. The problem is to obtain a plot of percentage of time vs. amplitude for any given signal voltage. The probability curves can be computed for simple signals such as square waves, sawtooth waves, and sine waves. The calculation becomes quite difficult for slightly more complicated waveforms and one may best resort to experimental methods for their determination.

The probability curves may be determined experimentally by any one of several means.

(1) The signal is recorded (photographically) as a function of time, and one measures the percentage of the total time interval spent within a small increment of amplitude. Such a method has been used but it is very expensive in time and material.

(2) The time function is applied to a cathode-ray oscilloscope and a long time exposure is made on a photographic film. The density of various parts of the record is measured with a microdensitometer and compared with calibration density records to obtain the true probability. This method has been tried. It is also very expensive in time and further is subject to unavoidable errors due to cathode-ray tube phosphor characteristics.

(3) A third method has been devised which produces a probability plot directly on a cathode-ray tube. The plot may be observed visually with the aid of a long persistence screen or photographed for subsequent study. Basically the scheme is as follows: The signal voltage to be analyzed is applied to the vertical deflection plates of a cathode-ray tube. A slowly varying sawtooth sweep is applied to the horizontal deflection plates. The face of the cathode-ray tube is completely masked with the exception of a narrow slit set at 45° with respect to the vertical. A portion of the light from the electron beam striking the screen comes through this slit

and falls on a phototube. The output current from the phototube is averaged, passed through a resistor, and the resulting voltage is amplified and applied to the vertical plates of a second cathode-ray tube. The vertical deflection thus produced is proportional to the percentage of time spent by the signal in the slit width. By using the same slowly varying sawtooth sweep on both cathode-ray tubes, a probability plot is obtained on the second tube. Figure VIII-4 shows several amplitude distributions and the

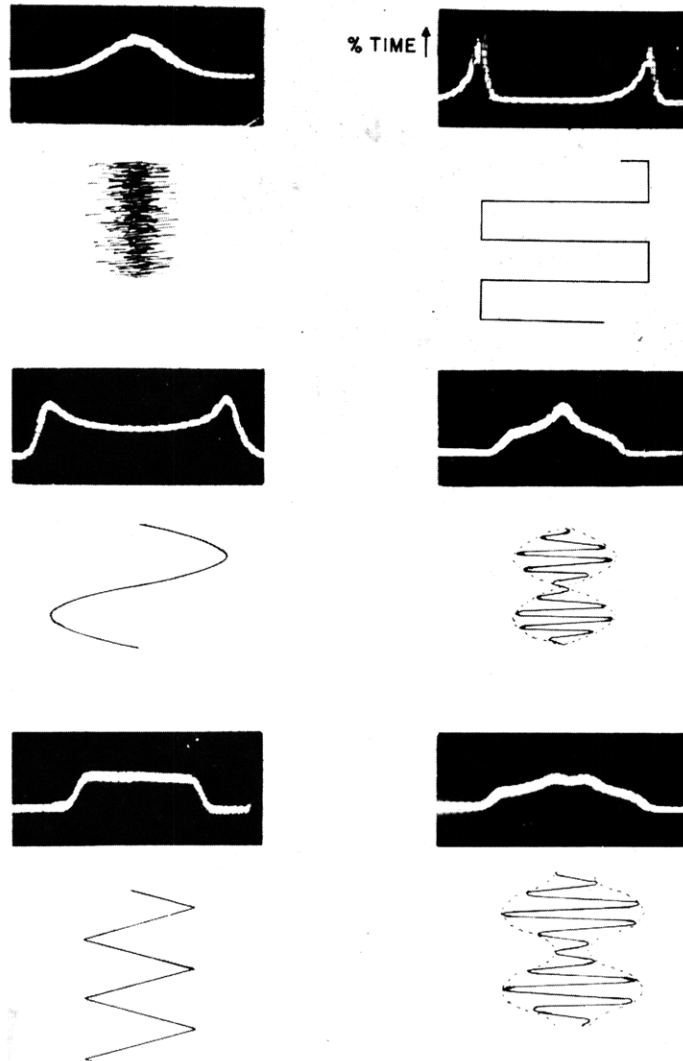

Fig. VIII-4. Amplitude distributions of a few signals.

corresponding time signals. These plots were obtained as explained above. The effect of the width of the slit can be seen in that the plots obtained do not have sharp discontinuities at the peak amplitudes. This method is good for a qualitative picture and as such has certain distinct advantages.

However, the problems of phosphor characteristics also enter here to give errors that cannot be compensated.

(4) Another scheme is being investigated which uses only receiving tubes. Basically the idea is to develop a pulse of constant height which begins whenever the signal to be analyzed enters the increment of amplitude under consideration and which ends when the signal leaves that increment, and to obtain the average pulse duration. This is accomplished by applying the signal directly to the grid of a pentode which is biased to a value that determines the lower limit of the amplitude increment. When the signal voltage at the grid exceeds the cutoff value, the pentode turns on. The input signal is also connected to a second tube which is biased slightly more negative than the first one. This bias determines the upper limit of the incremental amplitude. When the second tube is turned on, the negative pulse at its plate is used to turn the first tube off through its suppressor grid. The length of the pulse which results at the plate of the first tube is therefore proportional to the time spent by the signal within the specified incremental amplitude. This plate pulse is then squared and fed to an averaging circuit. A design of this scheme is being built at present. The first model is designed to accommodate input signals with frequency components between 50 and 20,000 cycles per second.

5. Information Theory

Staff: Professor R. M. Fano

Work is in progress on the statistical approach to communication problems. It has been stated by Wiener that information can be considered, from a statistical point of view, as negative entropy. By starting with the definition of unit of information as the answer to a yes-or-no question (the answer having the same a priori probability of being yes or no), it has been possible to obtain a detailed proof of Wiener's statement. An expression has also been obtained for the amount of information provided by a message corrupted by noise, when the message consists of a long series of independent indications of a point of an infinite line, and the probability distributions of both the signal and the noise are known. It is believed that the results of this work are not available at present in published form, but they are likely to be known to a number of workers in the field. A report on this subject will be written as soon as the material developed will warrant it.

6. Effects of Transit Angle on Shot Noise in Vacuum Tubes

Staff: G. E. Duvall

During the last quarterly period a transit-time diode has been constructed and put in operation at 30 Mc. Its anode is a kovar ring 6 cm

in diameter and 2 cm long; its cathode is a directly heated thoriated tungsten filament roughly concentric with the anode and also 2 cm long.

The amplifier and associated equipment for measuring the noise produced by this diode have been assembled and some preliminary measurements made. These measurements have served primarily as a guide to refinements in the equipment. It has been found necessary to replace the WE708A, which was originally used as a standard noise source, by a Sylvania X6030, which has proved very satisfactory. Fluctuations in the 15-ampere filament current of the transit-time diode have been minimized by using a ballast resistor. Over-all fluctuations in the gain of the amplifier have been reduced to about 5 per cent and at present a scheme is being considered which will make the noise measurements independent of slow changes in gain.

E. TRANSIENT PROBLEMS

1. Envelope Studies

Staff: Dr. M. V. Cerrillo

In the theory of the synthesis of networks for a specific transient response, it is important to obtain a compact analytical expression for the so-called "envelope" function of the whole wave. This envelope expression is also important in the transient theory to construct the final waves which result from the summation of a fairly large number of highly oscillatory components.

By using some of the results from the asymptotic solution of the integrals of the type $\int F(s)e^{W(s,t)} ds$, compact expressions for the envelope and phase deviation functions can be obtained for a rather general pole distribution of the function $F(s)$ and in the case in which $W(s,t)$ is not linear in s . Some results will be given in Technical Report No. 55. The general study of the envelopes for $w(s,t)$ linear and for another pole distribution of $F(s)$ is now under investigation.

2. Transient Theories

Staff: Dr. M. V. Cerrillo

An extensive study of the theory of asymptotic solutions of integrals of the type $\int_{\Gamma} F(s,t)e^{W(s,t)} ds$ has been completed and the corresponding final report (No. 55) is now under preparation. Integrals of the above type appear constantly in Fourier transforms, etc., and are connected with propagation of electromagnetic waves in dispersive media, with all sorts of electrical and mechanical transients, with the theory of frequency modulation, and with other problems. Also, these integrals have been used as a basic tool of network design for transient response.

A general discussion of the solutions of these integrals will be given for the initiation, main signal formation, and coda regions of transients.

3. Response of Networks to Frequency Transients

Staff: Professor E. A. Guillemin
D. M. Powers

The saddle-point method of contour integration is being applied to the problem of determining the response of electrical networks to frequency transients. In the Laplace transform method of solution a given time function is directly transformed to the frequency domain where it is multiplied by the system function of the network. An inverse transformation to the time domain gives the desired result. In the case of functions which represent frequency transients, the integrals involved in the transformations are solved by the saddle-point method.

In order not to obscure the procedures for solution, the simple case of a linear frequency transient was handled first. By treating time as a complex variable, the method of steepest descents was used to find the direct Laplace transform of the linear frequency function. This function was then applied to a simple parallel tank circuit. The tank circuit has two poles in its representation in the complex plane. The saddle point and the corresponding line of steepest descent move with time in the complex frequency plane. When the line of steepest descent touches a pole, main signal formation takes place and interest is therefore centered on the region of this formation. It was necessary to discover a way of evaluating the contribution in the vicinity of a pole, and this has been done. A complete solution will be presented later.

F. ACTIVE NETWORKS

1. General Theory

Staff: Dr. M. V. Cerrillo

Not much advance has been made in the general theory of active networks, mainly because all efforts were concentrated on the studies of the asymptotic solution of integrals as indicated in Secs. VIII-E1 and E2.

VIII. F. 2. Broadbanding of Amplifiers by the Use of Active Elements in the Interstage

Staff: Professor E. A. Guillemin
J. G. Linvill

The present topic is a sub-topic to the general problem of synthesis of active networks. For several months a study was made of the synthesizing of active networks through the use of linear constraints as explained in the last progress report; it appeared, however, that the solution to that general problem was much too distant to justify an attack along broad lines at this time. The present work was undertaken to consider a specific problem, the solution of which would throw light on the more general problem.

Bandwidth Limitations of Amplifiers with Passive Interstages. Bode¹ has shown that a passive two-terminal impedance which has associated with it a shunt capacitance, C , can present a constant magnitude of impedance up to a radian frequency of ω_0 of no greater magnitude than $2/\omega_0 C$ ohms. In view of the parasitic capacitance of the tubes, this fact establishes a maximum gain bandwidth product for any stage of an amplifier consisting of a pentode feeding a passive two-terminal interstage. The above result is obtained from the following relationship developed by Bode:

$$\int_0^1 \frac{\alpha}{\sqrt{1 - \left(\frac{\omega}{\omega_0}\right)^2}} d\frac{\omega}{\omega_0} + \int_1^\infty \frac{\frac{\pi}{2} + \beta}{\sqrt{\left(\frac{\omega}{\omega_0}\right)^2 - 1}} d\frac{\omega}{\omega_0} = \frac{\pi}{2} \ln \frac{2}{C\omega_0}$$

where

$$\ln Z = \alpha + j\beta$$

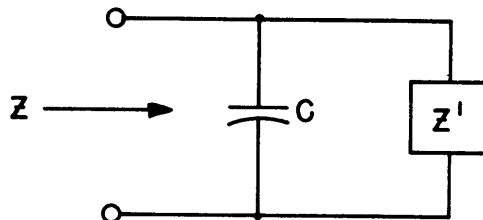

The optimum condition obtains when α is prescribed up to ω_0 as a constant, α_0 , and β is prescribed as $-\frac{\pi}{2}$ for frequencies above ω_0 , which condition may be approximated by an appropriate passive impedance.

Relaxation of Limitations for Interstage Impedances Realizable only with Active Networks. The preliminary thought that the use of active networks introducing negative capacitance to cancel the parasitic capacitance proves

1. H. W. Bode, "Network Analysis and Feedback Amplifier Design", Van Nostrand, New York, 1945, p. 408.

impractical when one finds that such active networks for high enough frequencies actually introduce more positive capacitance. From the following considerations it may be seen, however, that this added capacitance introduced by the active elements is not necessarily a limiting factor provided other conditions are appropriately chosen. That an impedance function with all poles and zeros in the left half-plane, behaving as a capacitance as $\omega \rightarrow \infty$, can have any arbitrarily high constant-impedance level up to any finite ω_0 is appreciated by consideration of the special distribution of poles and zeros shown (Fig. VIII-5). The poles and zeros are each distributed symmetrically

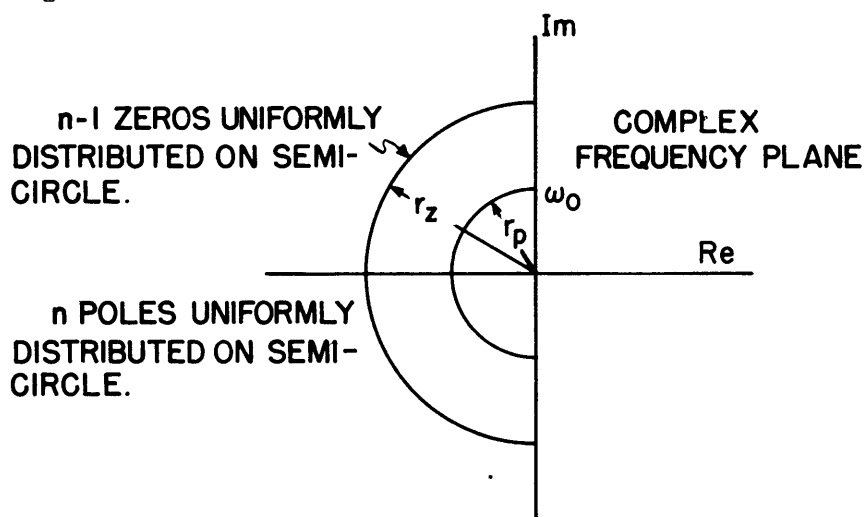

Fig. VIII-5.

with respect to the real axis. As may conveniently be shown by use of potential theory, such a distribution approximates a constant magnitude of impedance from $\omega = 0$ to $\omega = \omega_0 = r_p$ and in this range (if as $\omega \rightarrow \infty$ the impedance $\rightarrow 1/C\lambda$) the impedance level is r_z^{n-1}/Cr_p^n which for any value of n can still be fixed at will through an appropriate choice of r_z . Such an impedance function is not positive real, of course, and could not be realized by a passive network. The special configuration of poles and zeros shown above is not necessarily the optimum one for active impedances but merely illustrates that parasitic capacitance does not impose the same barrier on active impedance functions that it does on passive ones.

Consideration of a Particular Network Configuration for Active Interstages.

The next problem is that of considering possible network configurations which could be utilized in the network realization of impedance (or admittance) functions with all poles and zeros in the left half-plane (open-circuit and short-circuit stable) degenerating into a capacitance as $\omega \rightarrow \infty$. It is appreciated that the parasitic capacitance of tubes in the circuit must be accounted for in order that practical results be obtained. The first configuration to be considered is shown with its equivalent circuit in Fig. VIII-6.

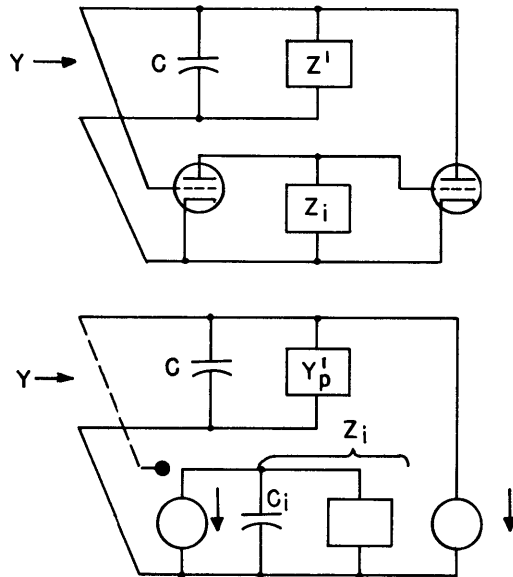

Fig. VIII-6. Simple active interstage and its equivalent circuit.

In Fig. VIII-6, C includes the output capacitance of the driving stage, and the input capacitance of the driven stage plus the input capacitance of the first tube of the interstage and the output capacitance of the last tube of the interstage. The grid-plate capacitances are not shown. Their influence is to shunt Y_p' by the series combination of $2C_{gp}$ and Z_1 (Z_1 is the plate load of the first tube of the interstage which must include the parasitic capacitance designated as C_1). This is a very slight influence because $2C_{gp}$ is small compared to C_1 or C .

The admittance presented by the network can be written as $Y = Y_p + Y_a$ where $Y_p = Y_p' + \lambda C$ and Y_a , the admittance presented by the active part of the interstage, is seen by conventional analysis to be $-g_m^2 Z_1$. Y_p must be a positive real function and Y_a must be a negative real function. The basic idea is to arrange the circuit in such a way that any negative conductance prescribed in a choice of Y will be supplied by Y_a .

The following procedure may be used to realize a network having an admittance with poles and zeros in the left half-plane in which the real part of Y ($\text{Re}Y$) is positive as $\omega \rightarrow \infty$ and the imaginary part of $Y \rightarrow \omega C$ as $\omega \rightarrow \infty$. First one evaluates the real part of a prescribed Y as $\lambda = j\omega$, finding it to be negative in certain regions. Then a Z_1 (including a capacitance, C_1) is found which has a real part in the regions of frequency where $\text{Re}Y$ is negative large enough that $-\text{Re}Y/g_m^2 < \text{Re}Z_1$. With such a Z_1 there results a Y_a supplying all of the negative conductance required by the prescribed Y . Then $Y - Y_a = Y_p$ is surely a positive real function and can be realized by standard procedures. The necessity for requiring that the $\text{Re}Y$ be positive as $\omega \rightarrow \infty$ arises from the presence of C_1 which requires that $\text{Re}Y_a \rightarrow 0$ as $\omega \rightarrow \infty$.

Consideration of this special network configuration brings up two possible difficulties which must be taken into account.

(1) $\text{Re}Y$ must never be so large while it is negative that physical tubes may not be found to make $\text{Re}Y_a$ of slightly greater magnitude.

(2) The size of C_1 imposes a limit on the integral of $\text{Re}Y_a$ over the frequency range from 0 to ∞ making the absolute value of this integral less than $\pi g_m^2 / 2C_1$ (Bode's resistance integral theorem). The importance of the limitations applying to the special network configuration is difficult to evaluate because they involve the physical limitations of vacuum tubes in a rather complicated way. As a first step a very simple arrangement of poles and zeros was tried giving a magnitude of impedance $6/\omega_0 C$ ohms which was fairly constant up to ω_0 . Work with this function indicated that its use in networks with a 30-Mc band requires tubes in the interstage of no greater factor of merit than is possessed by the 6AC7. The apparent advantage of 3-to-1 of this interstage over the optimum passive case should be reduced to $1\frac{1}{2}$ -to-1 since inserting the active components increased the parasitic capacitance by a factor of two. On the other hand, the simple example was worked out in such a way that the circuit would be stable for any value of g_m up to the prescribed value, and this precaution kept the relative advantage low.

The use of the special network configuration and, in particular, the example are of the nature of stabs in the dark from which it is necessary to go to more general cases. The possibility of evaluating the ultimate limit for the special network configuration discussed here is now being considered by looking for a more satisfactory way of splitting Y into $Y_p + Y_a$ and determining more definitely the seriousness of the limitations mentioned. Once this problem is solved other possible configurations will be tried if a change seems desirable to attain the practical limit. Finally it will be necessary to confirm the result by laboratory tests.

G. HIGHER MODE PROBLEMS

1. Steady-State Propagation of Electromagnetic Waves along Cylindrical Structures

Staff: Professor L. J. Chu
R. B. Adler

The solution to electromagnetic wave problems involving cylindrical symmetry have become of increasing importance in the electrical engineering field. The boundary-value problems involving guided waves, which had been treated primarily by the physicist in the earlier years, became significant in engineering applications, and their solutions were in need of reduction to systematic and practical procedures. The problems of the behavior of waveguides with discontinuities or current distributions

were handled by many people, in terms of the "normal modes" of propagation in the infinite guide. In order to reduce the problems to transmission-line equivalents, and to introduce the concepts of impedance, the properties of these normal modes must be understood thoroughly. In particular, their "orthogonality" properties in the cross section are of great importance in simplifying the calculations involved when more than one such mode is present. It is known, however, that these orthogonality properties are present only when the boundaries of the region containing the waves take certain simple forms. Among the most important of these forms is the perfect conductor. Moreover, the cross section within the boundaries must be uniformly filled with material of constant dielectric properties if the usual orthogonality conditions are to be used. Such conditions were fulfilled in the majority of earlier applications of waveguides. Now, however, there are a number of practical problems in which these conditions are no longer completely satisfied. The propagation of waves down cylindrical guides containing an electron beam is important in devices like the klystron and traveling-wave tube, and perhaps future development of millimeter-wave generation will also involve such problems. In addition, the requirement that the electromagnetic wave shall travel slowly in devices like the traveling-wave tube has led to the introduction of various "loaded" guides, and of the helical structure, to surround the beam. These problems do not admit of a "normal mode" solution in the same sense as ordinary waveguides, either because of the "open boundary" (like the helix) or because of a finite-size electron beam (like the loaded-guide traveling-wave tube). Yet a certain amount has been done in this direction by Hahn,^{1,2} Pierce,³ and Chu,⁴ although the meaning of the normal modes, and the method of combining them to satisfy boundary conditions in the absence of the orthogonality property, has not been made entirely clear.

It is felt therefore that further work should be done on the physical interpretation of "normal modes", and of the orthogonality conditions involved in separating them when more than one are simultaneously present. It appears that the multi-mode difficulties which come up in the practical problems cited above might possibly be separated by treating essentially four types of more idealized problems:

-
1. W. C. Hahn, "Small Signal Theory of Velocity-Modulated Electron Beams"; G. E. Rev., 42, 258, June 1939.
 2. W. C. Hahn, "Wave Energy and Transconductance of Velocity-Modulated Electron Beams"; G. E. Rev. 42, 497, November 1939.
 3. J. R. Pierce, "Theory of the Beam-Type Traveling-Wave Tube"; IRE Proc. 35, 111, February 1947.
 4. L. J. Chu and J. D. Jackson, "Field Theory of Traveling-Wave Tubes", RLE Technical Report No. 38, April 28, 1947.

- (a) Waveguide with "reactive wall", but uniformly filled with dielectric material.
- (b) Waveguide with perfectly conducting wall, but having a cross section only partially filled with dielectric.
- (c) Infinite dielectric cylinder in free space.
- (d) Waveguide with reactive wall, but completely or partially filled with an electron beam.

Although most of these problems have been treated previously,¹ at least in part, interest has almost always centered about the properties of individual modes, outside of their relations to one another and the means for separating them analytically when more than one are simultaneously present. In fact the very questions of their physical meaning, or completeness, for satisfying boundary conditions have not been clarified. Hahn² has suggested that in certain cases where dissipation is absent, the modes do form a complete set, which can be separated by using the fact that the time average flowing across each transverse section of the cylindrical system must be the same. The extent to which this point of view may be applied, beyond the cases treated by Hahn, should be determined, and the method clarified, particularly where radiation may be involved.

To date several of the problems cited have been examined, although the details have by no means been entirely completed:

(a) The circular waveguide with a reactive wall has been formally solved in the steady state for all modes, including those with angular variation. It has been found that the usual "orthogonality" of the scalar functions which describe the field cannot possibly hold under such boundary conditions, because of the necessity of supplying reactive energy to the walls. In addition, although it is at once clear from energy considerations that the real power flowing across every transverse section must be the same, it turns out that this conclusion is also valid for the reactive power. The latter fact does not follow immediately from a direct consideration of Poynting's theorem.

-
- 1. W. W. Hansen, Unpublished Lecture Notes (RLE Document Room T-2).
L. Pincherele, "Electromagnetic Waves in Metal Tubes Filled Longitudinally with Two Dielectrics"; Phys. Rev., 66, 118 (1944).
H. Bondi, M. D. L. Pryce, "Dielectric Cylinders as Waveguides", ASE Report M434, August 1942 (RLE Document Room No. 1723).
 - 2. W. C. Hahn, "Wave Energy and Transconductance of Velocity-Modulated Electron Beams"; G. E. Rev., 42, 497, November 1939.

(b) The circular waveguide with a perfectly conducting wall and a center "conductor" of lossless dielectric has been similarly investigated, but only for the circularly symmetric modes of propagation. Again, the usual orthogonality properties must fail because of the additional reactive energy stored in the center rod, but the longitudinal components of both real and reactive power flow over the cross section are conserved. The consideration of modes which are not circularly symmetric would not appear to add anything significant to the results, because of similarity to case (a).

(c) The waveguide with a reactive wall, but completely filled with an electron beam, has been partially studied for the circularly symmetric modes. Only enough work has been completed to see that the "modes" are similar to those in the iris-loaded traveling-wave tube, and that the usual orthogonality of the scalar functions does not hold. There is considerable question about the approximations made regarding the electron beam in this problem, and these should be settled before continuing along the line of this investigation.

(d) At present the propagation of waves along an infinite dielectric cylinder in free space is being re-examined. Although it has not been emphasized in the literature, it appears that for any given frequency and cylinder constants there are only a finite number of guided cylindrical waves for each type of circular variation in the fields; in fact there are no "cut-off" modes in the normal sense. This conclusion would appear to apply to any "open structure", like a helix for example, and the question of the completeness of the modes, or their physical meaning in the helix case, is still an open one. As an introduction to the understanding of such situations, the solution to the problem of an infinite dielectric rod containing a dipole source on its axis is currently being examined.

2. Transmission Through Large Metallic Waveguides

Staff: Professor L. J. Chu
T. Moreno

If a waveguide connecting a generator and load is sufficiently large to be above cutoff for more than one transmission mode, the problem of energy transmission may be attacked by considering the waveguide as a number of transmission lines connecting generator and load, with each transmission line equivalent to one mode of transmission in the waveguide.

From this point of view, the existence of inter-mode resonances in the waveguide was predicted. For the particular case of two transmission modes, the characteristics of these resonances have been examined, and expressions have been obtained for the input impedance of the guide, for

the power loss in the resonances, and for the spacing of the resonances and their severity as affected by such parameters as line length, attenuation, and relative strength of excitation of the transmission modes. Criteria have been established which give the required purity of mode excitation and required attenuation to reduce these resonances to negligible amounts. Similar detailed results have not yet been obtained for more than two transmission modes, although the resonances have been shown to exist under these conditions.

Experimental work has consisted of transmitting 1-cm waves through 3-cm and 10-cm rectangular waveguides, with horn antennas at each end. The predicted resonances have been found, and the 3-cm guide results correlated with the two-mode theoretical analysis (for reasons of symmetry, only two of the above-cutoff modes are excited). Experimental results with the 10-cm guide have not yet been fully explained, although resonances have been found.

H. LOCKING PHENOMENA IN MICROWAVE OSCILLATORS

Staff: Professor J. B. Wiesner
E. E. David, Jr.

Studies of a pulsed magnetron, synchronized by an invariant c-w signal, are being continued. Correlations of magnetron starting noise and phase, as they affect the locking action, are to be made.