



PRODUCTION OF FURFURALDEHYDE FROM D-LYXOSE AND D-RIBOSE

by

ALVIN GUTTAG

SUBMITTED IN PARTIAL FULFILLMENT OF THE
REQUIREMENTS FOR THE DEGREE OF

BACHELOR OF SCIENCE

from the

MASSACHUSETTS INSTITUTE OF TECHNOLOGY

1940

Signature of Author*y*.....

Department of Chemistry, May 16, 1940

Signature of Professor

in Charge of Research

Signature of Head of Department*y*.....

✓

ACKNOWLEDGMENTS

28

I wish to express my sincere thanks to Professor Robert C. Hockett for his kindly advice and help. I also would like to thank Dr. B. Edwin Blaisdell, Worden Waring and Henry Harrison for their help in making this thesis a success.

Table of Contents

INTRODUCTION	1-18
A. Discussion of Pentoses and Pentosans	1-3
B. Determination of Pentoses	3-5
C. Methods of Pentose Determination	5-13
1. Tollen's Phloroglucinol Method	5-8
2. Barbituric Acid Method	8
3. Thiobarbituric Acid Method	8
4. Bisulphite Method	9
5. Bertrand Method	9-10
6. Phenylhydrazine Method	10
7. Bromate-Bromide Method	10-11
8. Acree Modification of the Bromate-Bromide Method	11-13
D. Results of Other Investigators	13-17
E. Object of this Thesis	17-18

Table of Contents

EXPERIMENTAL WORK AND RESULTS	19-37
A. Preparation and Purification of Reagents Used in the Standard Procedure	19
B. The Standard Phloroglucinol Procedure	19-21
C. Results of Determination of Xylose and Arabinose by the Standard Procedure	21-22
D. Results of Determination of d-Lyxose by the Standard Procedure	22-24
E. Results of Determination of d-Ribose by the Standard Procedure	24-28
1. Preparation of Crystalline Ribose	24-27
2. Results Obtained with the Standard Procedure	27-28
F. Conclusions on the Standard Phloroglucinol Procedure	28-29
G. Steam Distillation Procedure	29-37
1. Preparation of Additional Reagents	29-30
2. Test of Technique	30-31
3. Steam Distillation of Furfural from d-Lyxose	31-34
4. Calculation of the Order of Reaction for the Production of Furfural from d-Lyxose by a Steam Distillation	34-36
5. Test Run on d-Xylose	36
6. Results with d-Ribose	36-37
SUMMARY	38-39
BIBLIOGRAPHY	40

INTRODUCTION

A. Discussion of Pentoses and Pentosans

In the sugar series there are theoretically 2^n isomers if n is the number of asymmetric carbon atoms. Theoretically there should be eight open chain aldopentoses. All eight have been discovered. The four d-forms may be represented by the following formulae:

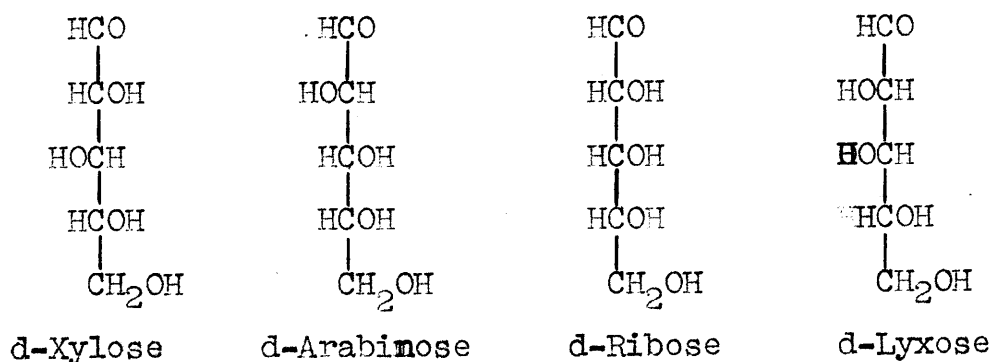

The enantiomorphs, l-Xylose, l-Arabinose, l-Ribose, and l-Lyxose, may be pictured as the mirror images of the corresponding d-forms.

Pentoses occur in nature as the free sugars or, more commonly, as polysaccharides or "pentosans". The pentosans are of a similar structure to cellulose. For example xylan has the structure shown on the next page.

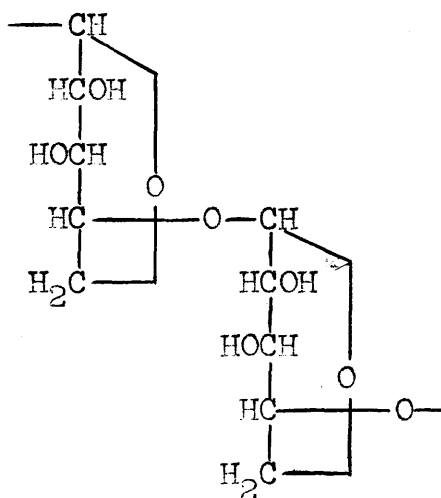

Pentoses also occur in nature occasionally as components of disaccharides. (I)

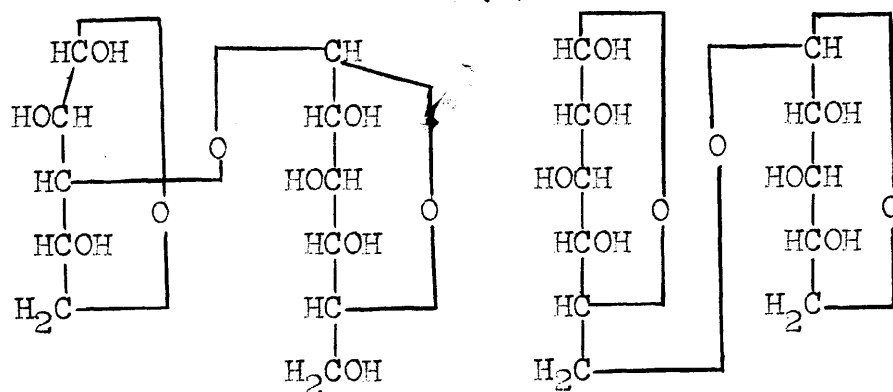

d-glucosido- d-arabinose

primverose

The most common pentose found in nature is d-xyloosan. It occurs in straw, wood, bran, cottonseed hulls, oat hulls, corn cobs and many other places.

L-arabinose is found next most abundantly. It has been isolated from pectin, gum arabic, cherry gum, cottonseed husks and sugar beet residues. (I, II)

The d-form of this sugar is much rarer but it has been discovered in the tubercle bacilli and in barbaloin. (II)

D-ribose has been found in small quantities in nature. Both plants and animals contain it in nucleic acids. (I) It has become important recently because it is one of the elements of Vitamin B₂ (riboflavin).

So far lyxose is the only pentose which has not been found in nature. However, there is good reason for believing that it will be found in natural sources because **mannuronic acid**, which forms lyxose by losing CO₂, occurs in certain seaweeds.

Frequently associated with d-xylose in natural materials is glucuronic acid. Similarly galacturonic acid is found together with l-arabinose. As the percentage of pentoses in a young growing plant is smaller than in the later stages of its growth it is probably a fact that the uronic acids break down to the pentoses and CO₂. (IV)

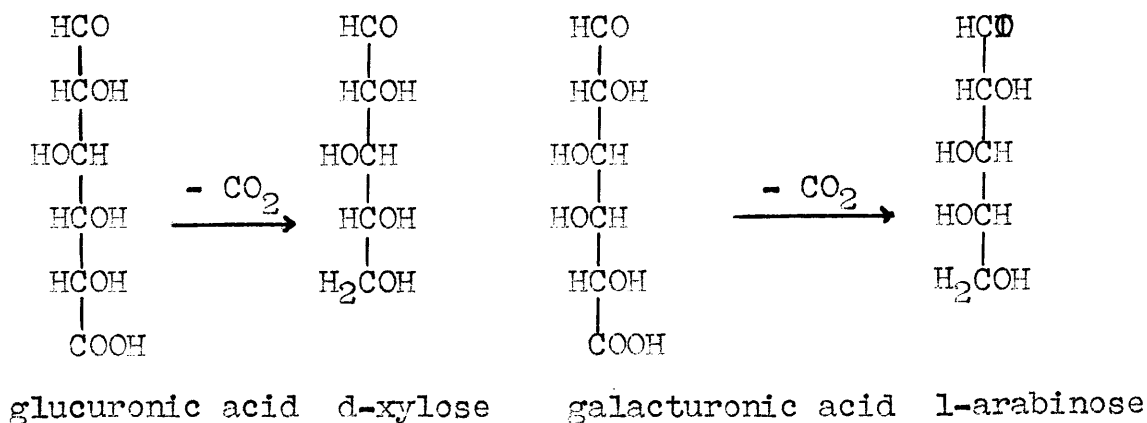

B. Determination of Pentoses

Hexoses and pentoses frequently occur together. The problem arises to find a means of determining pentoses in

the presence of hexoses. Both form phenylhydrazones, osazones, oximes and react similarly in many other ways. However, pentoses give furfuraldehyde when treated with hot acids while hexoses give unstable hydroxymethyl-furfuraldehyde. The reaction of the pentoses is given below.

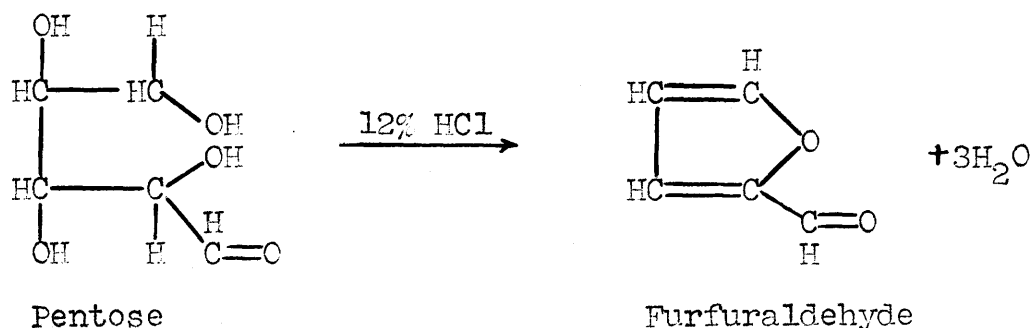

All the common methods of determining pentoses depend upon this reaction. They vary only in the way in which the furfural is determined after it is obtained.

In addition to the pentoses the uronic acids also give furfural because they lose CO₂ in hot acid and form the corresponding pentoses. Corrections must be made therefore for the presence of uronic acids. The amount of uronic acid present can be easily determined because they lose CO₂ quantitatively. (III,V) Because they do not form furfural quantitatively it is difficult to make the necessary corrections for them.

The methyl pentoses give methylfurfural with the acid treatment and correction must also be made for them. This is easier to do than in the previous case because the yield

of methyl furfural has been accurately determined by several investigators. Furthermore some of the methods of determination readily distinguish between methyl furfural and furfural. For example in the standard phloroglucinol method the precipitate with methyl furfural is soluble in alcohol while that with furfural is insoluble in alcohol. (III)

The situation has been further complicated because until recently no method had been devised which would report theoretical yields of furfural from the pentoses. In every case less furfural was obtained than was equivalent to the samples used. This has been taken advantage of though in simultaneously determining the amounts of two different pentoses in a sample. A glance at Figure 1 will show why this can be done.

C. Methods of Pentose Determination

In the next few pages are summarized the more important methods of determining pentoses.

1. Tollen's Phloroglucinol Method

This is the oldest of all the methods. Because the technique and apparatus involved are relatively simple in this method and because none of the others have been shown to give better results it is the only one recognized as standard by the Association of the Official Agricultural Chemists of America.

The sample to be tested for pentose is placed in a distillation flask with one hundred milliliters of 12% hydrochloric acid. The liquid is distilled off at a rate

of thirty milliliters every ten minutes. At the end of each ten minute period acid is added to the distilling flask through a separatory funnel so that the volume is again one hundred milliliters. The distillation is continued in this manner until no more furfuraldehyde is detected in the distillate. The furfural may be tested for with aniline acetate paper. As long as furfural is present a pink color is obtained. When there is no longer a test for furfural in the distillate a solution of phloroglucinol in 12% hydrochloric acid is added and the distillate is diluted to exactly four hundred milliliters with 12% hydrochloric acid. In no event is the distillation continued beyond the time when the combined volume of the distillate and the phloroglucinol solution to be added to it is **equal** to four hundred milliliters. (III,VII)

After the addition of the phloroglucinol solution to the distillate the initial light yellow color of the mixture gradually darkens and then turns to a deep greenish black. The precipitate obtained at this point is believed to be formed by one of the following reactions:

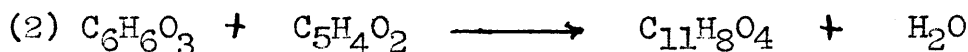
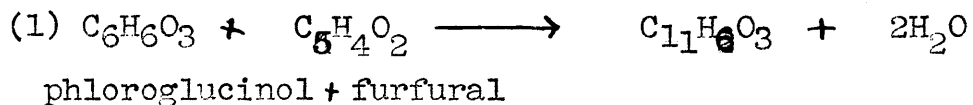

The precipitate is allowed to stand overnight and is then collected on a gooch crucible and weighed.

By taking samples of a pure pentose but of varying weights a graph may be made of the weight of precipitate against the weight of the sample of pentose. The results may also be used to find the constants in the following equation. (VIII)

$$A = a + bp$$

A is the weight of the sample

a and b are constants which vary with the pentose used

p is the weight of the precipitate

However, there are several disadvantages to the phloroglucinol procedure. An important one is that substances other than furfural also form precipitates with phloroglucinol. Many of these such as methyl furfural form precipitates which are soluble in alcohol. As this solvent does not dissolve the furfural precipitate they can be corrected for. (III,IX) Not all interfering constituents in plants can be removed in this way though and they give rise to inaccuracies in the method.

There are further difficulties which stem from the importance of standardization of the apparatus used. For example, slightly different results are obtained if the distillation is carried out at thirty one milliliters

every ten minutes instead of thirty milliliters every ten minutes. Finally, because of the length of time involved in this procedure it is not one which is advisable for use in routine analysis.

Because of the several disadvantages of the standard method other methods have been devised with the aim of eliminating them.

2. Barbituric Acid Method

This method is similar to the phloroglucinol one just described except that barbituric acid is the precipitating agent. The reaction proceeds according to the equation

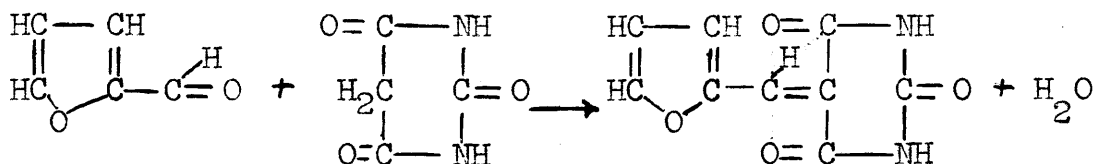

In this case correction must also be made for a slight solubility of the precipitate in 12% hydrochloric acid. One of the advantages of this method is that hydroxymethyl 2 furfuraldehyde, an interfering constituent in the phloroglucinol method, is not precipitated by barbituric acid. It has not been proved to be more accurate than the standard method, however. (X,XI)

3. Thiobarbituric Acid Method

This modification is identical with the last one except that precipitation occurs through the use of thiobarbituric acid. It has been found to be inadequate for small amounts of furfuraldehyde. (XII)

4. Bisulphite Method

Originally this method was tried by Jollé with potassium bisulphite. It has been tried with equal success with sodium bisulphite. In contrast to the methods previously described it involves a volumetric determination. The furfural formed is distilled with steam in an attempt to prevent the furfural from decomposing in the distilling flask. The distillate is neutralized and a measured amount of either sodium or potassium sulphite is added. The excess bisulphite is titrated with standard iodine solution using starch as an indicator. Thus the amount of bisulphite combined with the furfural and the amount of furfuraldehyde itself can be determined indirectly. This method is one of questionable accuracy and difficult technique, however. (III, XIII)

This method gives one important contribution to pentose determination. It is the first method which attempts to obtain 100% yields of furfural directly and thus not depend on a graph or formula for finding the amount of pentose present. Later Acree showed that a plain steam distillation would not be successful in driving over all the furfural before it decomposed. (XIV)

5. Bertrand Method

This is another volumetric method. The furfural in the distillate is treated with Fehling's solution. The cuprous oxide produced is titrated with standard potassium permanganate solution. Although there have been reports of

satisfactory results the accuracy of the method is in dispute. (XV, XVI)

6. Phenylhydrazine Method

In this method the furfural is treated with phenylhydrazine. The precipitated phenylhydrazone is filtered off and the excess phenylhydrazine is determined with excess standard iodine solution. The excess iodine is back titrated with standard thiosulphate solution. As can be seen by the following reaction one mole of phenylhydrazine is equal to four equivalents of iodine.

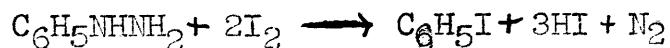

The authors claim that the results of this method agree closely with those of the standard method. (XVII)

7. Bromate-Bromide Method

The furfural is obtained in a manner similar to the phloroglucinol method. In an effort to increase the distillation yields twenty grams of sodium chloride were added to the distillation flask. Two samples of one hundred milliliters each are taken from the four hundred milliliters of distillate and the acidity is neutralized with sodium hydroxide. Then to each sample are added ten milliliters of ammonium molybdate solution and then twenty five milliliters of a standard bromate-bromide solution approximately 1/20 normal in bromate. The flask is placed over a white surface and the

liquid is allowed to stand for four minutes after a yellow color appears. (This color should appear in less than two minutes.) Then one gram of solid potassium iodide is added and the solution is shaken. After five or ten minutes the excess iodine liberated is titrated in the usual way with standard sodium thiosulphate. The bromate consumed by the furfural is equal to the total bromate added minus the bromate equivalent to the thiosulphate required. (III, XIV)

The main reaction that occurs is:



The method is quicker than the phloroglucinol method but it is no more accurate and it too does not give 100% yields.

8. Acree Modification of the Bromate-Bromide Method

This is the newest of the methods and gives indications of being the best in several respects. The main work on this method is reported in two papers. (XIV, XVIII)

In the earlier paper Acree and Hughes report their failure to obtain 100% yields of furfural by a slow steam distillation. However, they reported success in obtaining 100% yields of furfural from xylose by using a fast steam distillation and a solution of hydrochloric acid saturated with common salt in the distillation flask. Briefly the procedure is as follows:

The pentose is placed in a solution of 12% hydrochloric acid to which twenty grams of sodium chloride have been added. Steam is passed through rapidly and the distillation

is carried out at a rate of two hundred milliliters every half hour in contrast to ninety milliliters every half hour and without the aid of steam in the standard procedure. As in the standard method more acid is added to the distillation flask as it is needed. The acidity of the distillate is adjusted to about one normal and the furfural is determined by the bromate method except that no ammonium molybdate is added.

Acree and Hughes found that if the bromate solution was allowed to act for exactly five minutes at 0°C. only one mole of bromine would be added by furfural. With methylfurfural after five minutes 1.38 moles of bromine were added. These values were constant provided that the time of interaction was just five minutes. However, with methylfurfural eventually over two mols would be added and with furfural slightly more than a mole was found to add after ten minutes. (XIX)

This method differs from the others in that the distillation is continued beyond the point where four hundred milliliters of distillate are obtained. In this method the distillation is continued until there is no longer a test for furfural in the distillate.

Different pentoses and methyl pentoses can be distinguished by this method because it has been found that it takes them different lengths of time to arrive at 100% yields.

It has been found that common salt is the best one to use in the distillation flask. Many other salts were tried but in no case did they shorten the time required for complete furfural formation and in some cases they failed to give 100% yields. (XVIII)

As mentioned previously this method is significant because it gives 100% yields of furfural from pentoses. Its chief disadvantage is that it takes a long time and continual watching.

D. Results of Other Investigators

Kröber's tables have long been used as the standards for the determination of arabinose and xylose. These tables were made from results obtained by the phloroglucinol method. Representative values from the tables are given below. (All the values are in grams.) (VI)

Precipitate	Arabinose	Araban	Xylose	Xylosan
.030	.0391	.0344	.0324	.0285
.060	.0721	.0634	.0598	.0526
.090	.1051	.0925	.0872	.0767
.120	.1380	.1214	.1146	.1008
.150	.1710	.1505	.1419	.1249
.180	.2039	.1794	.1692	.1489
.210	.2363	.2079	.1965	.1729
.240	.2687	.2365	.2239	.1970
.270	.3011	.2650	.2511	.2210
.300	.3335	.2935	.2784	.2450

To convert the value for the simple pentose to that of the pentosan it is only necessary to multiply the weight of the pentose corresponding to the phloroglucinol precipitate by the factor 0.88.

In graphic form the tables for xylose and arabinose are shown in figure one.

Several years after Kröber's tables were published similar work was done on the methyl-pentoses by Mayer and Tollens. In the case of the methyl-pentoses the precipitate formed is red in color rather than a greenish black.(XX) The tables they arrived at are given below. (XX,XIII)
All values are weights in grams

Precipitate	Fucose	Rhamnose
.010	.0260	.0266
.015	.0377	.0343
.020	.0489	.0423
.025	.0594	.0500
.030	.0693	.0578
.035	.0786	.0655
.040	.0874	.0731
.045	.0954	.0803
.050	.1029	.0879

To convert the values of the simple methyl-pentoses to those of the methyl-pentosans it is necessary to multiply the weight of the pentoses corresponding to the phloroglucinol precipitates by the factor 0.89.

Figure 1
Phloroglucinol Precipitate vs. Pentose

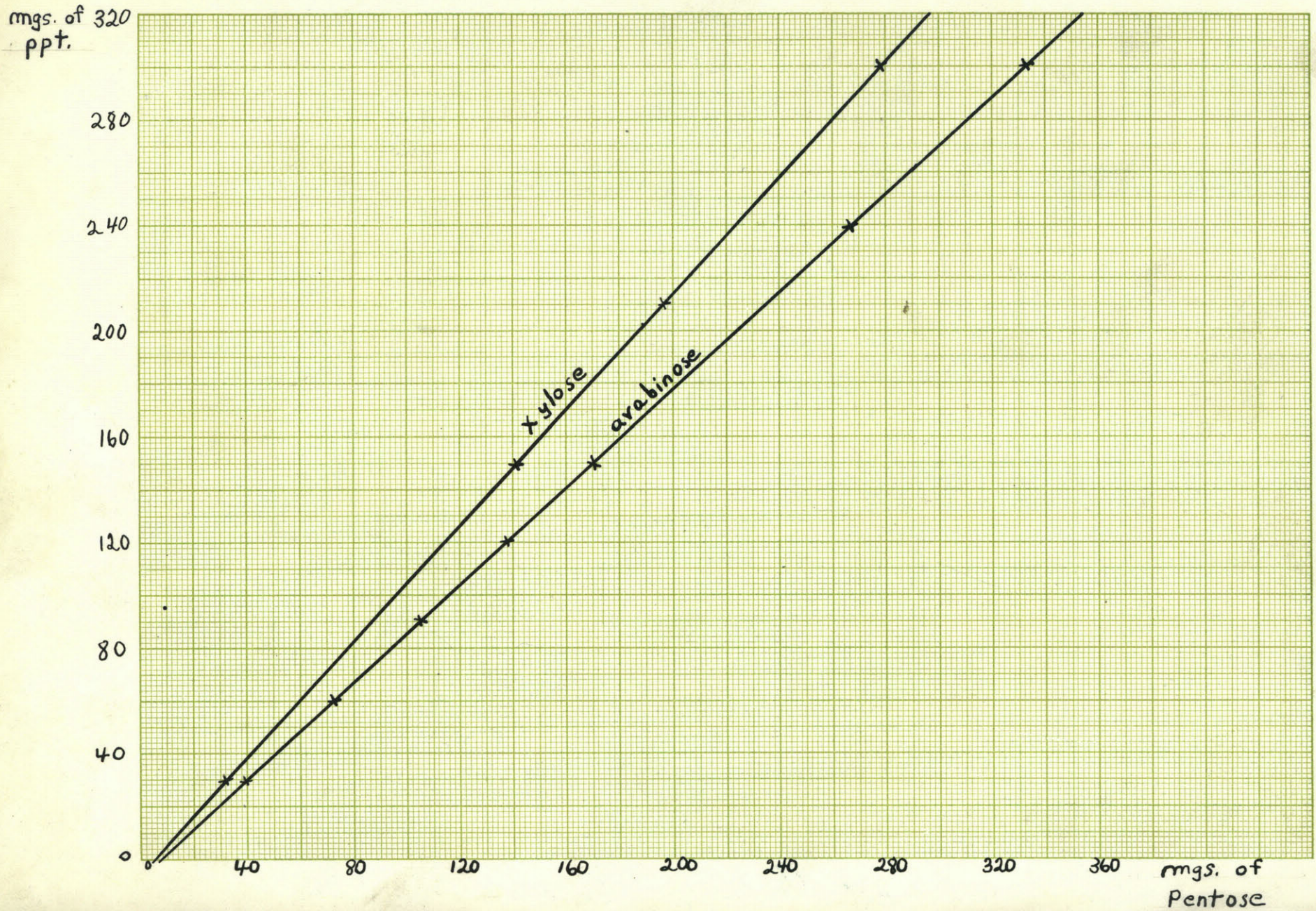

The tables for fucose and rhamnose are expressed graphically in figure two. By comparing figure two with figure one it is readily seen that the methyl-pentoses give much lower yields of the precipitate for a fixed weight of sample.

It was previously mentioned in this thesis (Page 7) that the following equation could be used to obtain the weight of pentose corresponding to a known weight of phloroglucinol precipitate:

$$A = a + bp$$

A slightly different equation is used with the methyl-pentoses:

$$A = a + bp + cp^2$$

A is the weight of the methyl-pentose

a, b, and c are constants

p is the weight of the phloroglucinol precipitate

The exact equation for **fucose** is:

$$\text{fucose} = .0586 + 2.660p - .0123p^2 \quad (\text{XX})$$

The equation for rhamnose is:

$$\text{rhamnose} = .004 + 1.85p - .00625p^2 \quad (\text{XIII})$$

Last year for the first time work was done on making a similar table and graph for d-lyxose. (II) Smith, who did the work, gave the following reasons for choosing the phloroglucinol method:

1. It is the only pentose-pentosan determination that is officially accepted by the Association of Official Agricultural Chemists of America.

Figure 2

Phloroglucinol Precipitate vs. Methyl-pentose

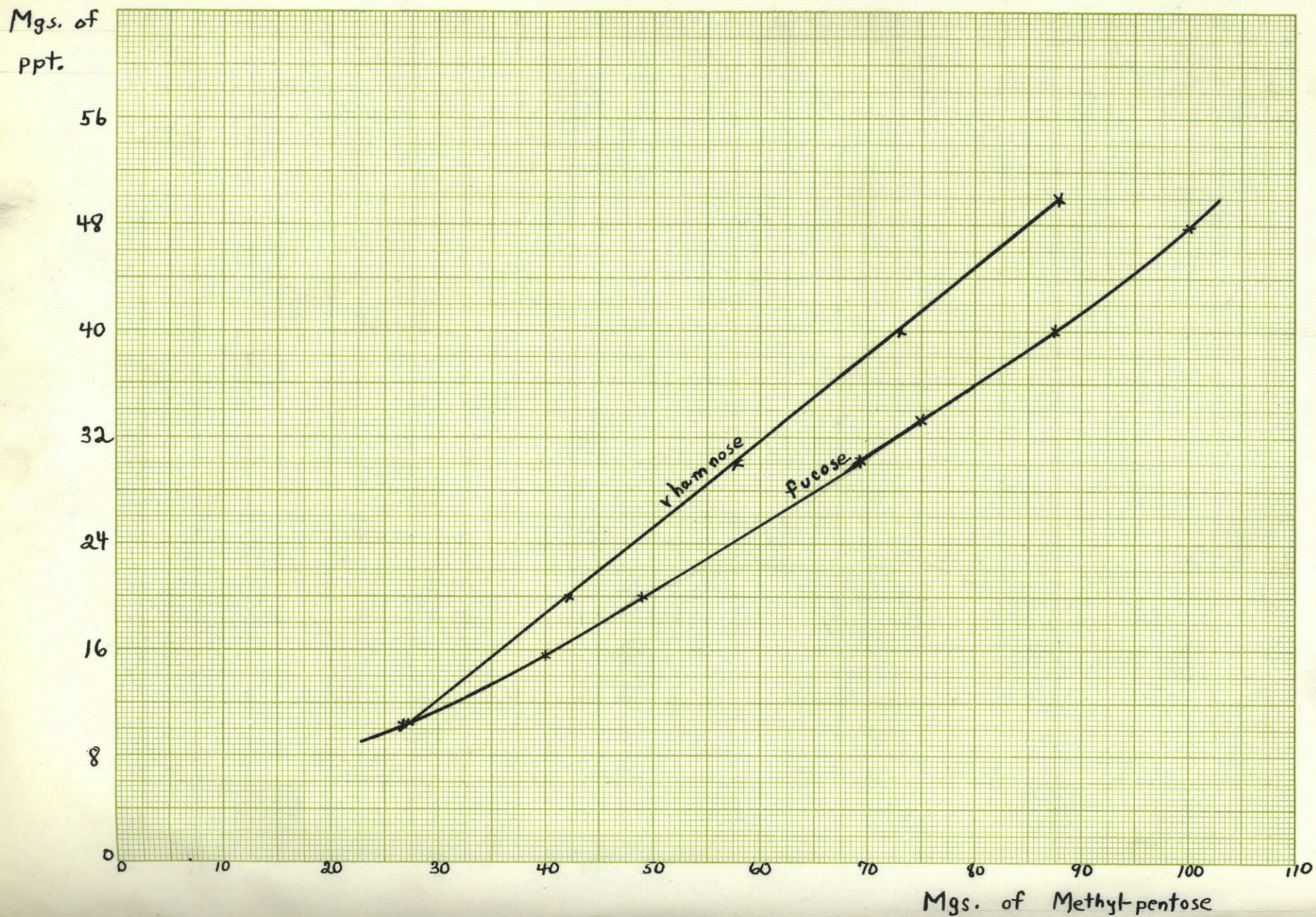

2. It is the method that was employed in making Kröber's tables which are universally used in pentose determinations.

3. It is the method that possesses the largest amount of supporting evidence that it is representative of the best attainable accuracy.

4. Erratic results due to interfering constituents found present in practical use are eliminated when pure pentoses are used.

5. The technique and apparatus required for this procedure are relatively simple.(II)

The results he obtained are given below. (All weights are given in grams.)

d-lyxose	precipitate	d-lyxose	precipitate
.0100	.0080	.1000	.0915
.0200	.0173	.1000	.0911
.0200	.0172	.1500	.1295
.0300	.0264	.2000	.1749
.0500	.0443	.2000	.1729
.0700	.0604	.3000	.2598

From these values Smith obtained the equation

$$\text{lyxose} = .0044 + 1.142p$$

His results are also shown graphically along with mine in figure four. By comparing figure four with figure one it is readily seen that lyxose gives a smaller yield of precipitate for a fixed weight of sample than does either arabinose or xylose.

As stated earlier in this thesis a new method has been reported within the last two years which gives 100% yields

Figure 4
Phloroglucinol Precipitate vs. Lyxose

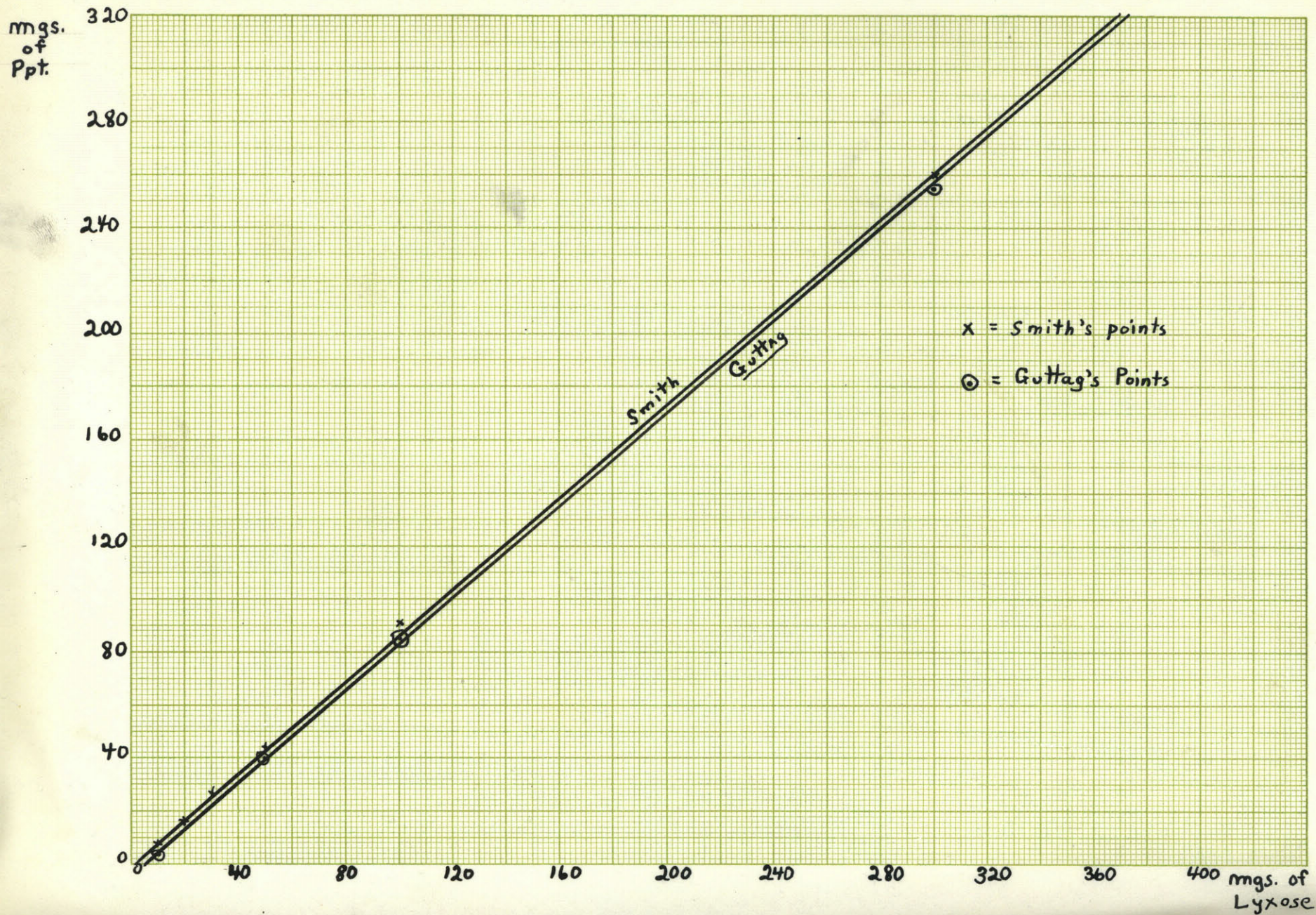

of furfural and methyl-furfural from pentoses and methyl-pentoses. (XIV,XVIII) This method has been tried on xylose, arabinose and rhamnose. In every case it gives 100% yields. The investigators report that the results with rhamnose were the most erratic. This is due, no doubt, to the fact that the amount of bromine added by methyl-furfural changes quite rapidly with time and it is therefore extremely important that a reaction time of just five minutes be permitted between the bromate solution and the distillate. (XIX)

Acree and Hughes also pointed out in their latest report, (XVIII), that each sugar took a different length of time to complete the formation of furfuraldehyde. Thus the different sugars may be identified by this method and it is also possible to find out the percentage of each sugar present in a mixture of pentoses.

The time curves for xylose, arabinose and rhamnose are shown in figure three which is an enlargement of the graph given by Acree and Hughes on page 295 of Volume 23 of the Bureau of Standards Journal of **Research**.

E. Object of this Thesis

Last year Smith obtained values for the formation of furfural from lyxose. One of the purposes of this thesis is to obtain checks on those values. As yet no data has been obtained on the quantitative determination of ribose. Because it has been found naturally it is important that this work should be done. In this thesis a start will be made in the quantitative determination of ribose.

Figure 3
Yield of Furfural vs. Time of Distillation

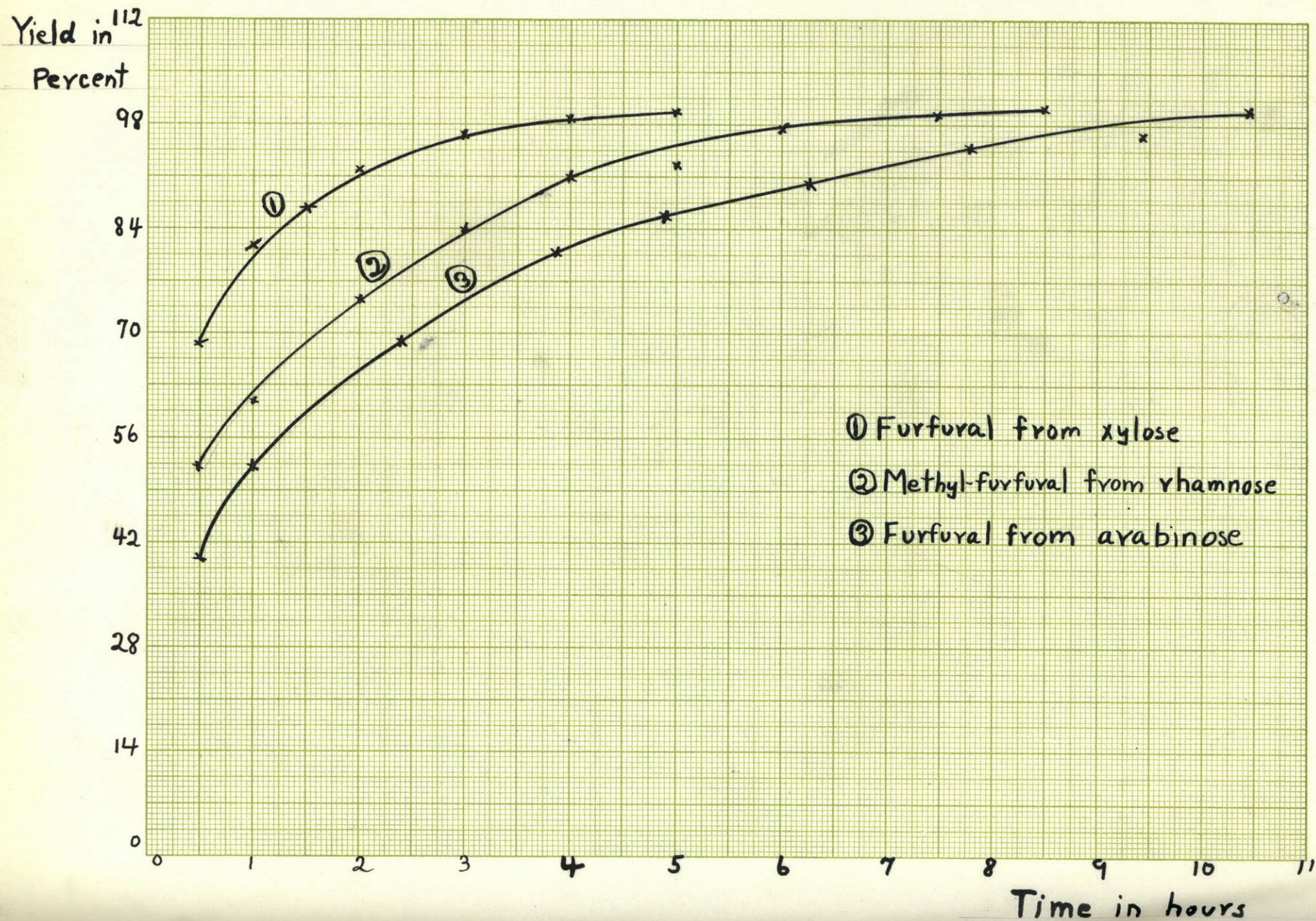

The method giving 100% yields of furfural has not been tried yet on lyxose and ribose. This thesis will undertake the task of discovering whether or not these pentoses also give 100% yields. Furthermore time curves will also be plotted for lyxose and ribose if it turns out that they do give 100% yields.

EXPERIMENTAL WORK AND RESULTS

A. Preparation and Purification of Reagents Used in the Standard Procedure

Twelve per cent (3.49 N) hydrochloric acid was prepared by adding distilled water to concentrated hydrochloric acid, sp. gr. 1.19. The amount of water required as a diluent was calculated by assuming that twelve per cent hydrochloric acid had a sp. gr. of 1.06. The normality of the acid used varied from 3.55 to 3.78 in the four batches of acid prepared.

Aniline acetate, which gives a pink color with furfural, was used as a test reagent to determine when furfural was no longer present in the distillate. This reagent was made by adding 20 cc. of aniline to 20 cc. of water and then adding glacial acetic acid until complete solution occurred.

Phloroglucinol solution was made by adding 10.9 grams of phloroglucinol to 1500 cc. of 3.547 N hydrochloric acid. This solution was always filtered before being used.

Samples of pure crystalline d-xylose, d-arabinose, l-arabinose and d-lyxose were dried in a vacuum oven overnight and then were stored in a desiccator. The preparation of d-ribose is described later in this thesis.

B. The Standard Phloroglucinol Procedure

An important factor in the accuracy of results obtained by this procedure is the apparatus used. For example, until ground glass joint 2 (Diagram A) was introduced into

Diagram A

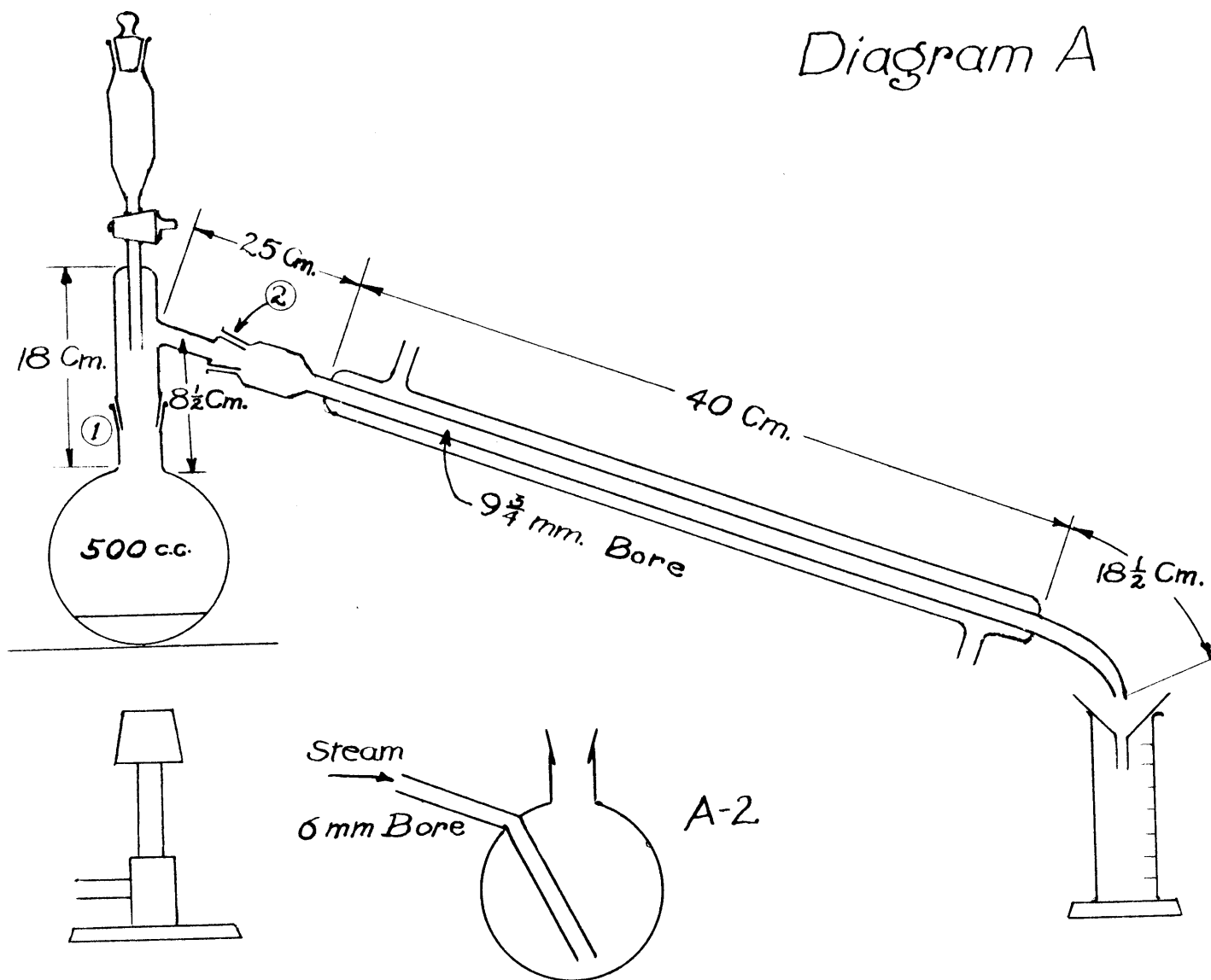

the apparatus in place of a cork or rubber stopper it was impossible to obtain consistent results with small samples of pentose. Diagram A gives a description of the apparatus used and important dimensions.

The exact procedure followed in the determination of the pentoses by the standard phloroglucinol method was as follows:

The weighed sample of pentose (between .01 gram and .3 gram) was placed in the distilling flask and then 100 ml. of approximately 12% hydrochloric acid was added and distillation was then maintained at a rate of 30 ml. in ten minutes. The bunsen burner (or, in the runs with d-ribose, the electric heater) was readjusted from time to time in order to maintain this rate. At the end of ten minutes 30 ml. more of acid solution were added through the dropping funnel and the 30 ml. of distillate which had collected in the previous ten minutes in the graduate were poured into a 500 cc. stoppered erlenmeyer flask. This process was continued until 360 ml. had been collected or, if the distillate gave a negative test with aniline acetate reagent (absence or a pink color) before that point, until the negative test was given.

Then phloroglucinol solution slightly in excess of that amount needed for complete precipitation of the furfural obtained was added. (The weight of phloroglucinol required to completely precipitate a 100% yield of furfural

from apentose is equal to the weight of the pentose times 126/150.) Next the volume of liquid in the collection flask was made up to 400 ml. A precipitate was gradually formed and this was allowed to settle overnight. The precipitate was then collected on a Gooch crucible which had previously been dried overnight at 105-110^o C. and weighed. The precipitate was washed with exactly 150 cc. of distilled water. Then the crucible containing the precipitate was placed in the drying oven at 105^o C. and left overnight. Finally the crucible was reweighed. The difference in the two weighings was the weight of the precipitate. As the precipitate is hygroscopic all weighings were made in a weighing bottle.

C. Results of Determination of Xylose and Arabinose by the Standard Procedure

The following tables were obtained by treating d-xylose, d-arabinose and l-arabinose according to the standard procedure and recording the results

d-xylose

Gms. of sugar	Gms. of ppt.	Duplicate error in grams	Kröber table value	Error with table	Smith value	Error with Smith value
.0603	.0639	.0021	.0604	+ 4.0%	.0615	+ 2.1%
.0603	.0618	-	-	-	-	-
.1000	.1027	.0009	.1040	- 0.8%	.1044	- 0.8%
.1000	.1036	-	-	-	.1034	-

d-arabinose

Gms. of sugar	Gms. of ppt.	Duplicate error in grams	Krober table value	Error with table	Smith value	Error with Smith value
.0500	.0378	.0010	.040	- 4.4%	.0451	-14.5%
.0500	.0388	-	-	-	.0446	-
.2000	.1775	.0000	.1764	+ 0.6%	.1851	-4.1%
.2000	.1775	-	-	-	-	-

l-arabinose *

.2000	.1598	.0028	.1764
.2000	.1626		

* The l-arabinose used had an $[\alpha]_D^{20}$ of 96.1° according to Smith (II). Pure l-arabinose has an $[\alpha]_D^{20}$ of 105° . Assuming that all the impurities in the arabinose are of a type which do not have an optical rotation the corrected weights of precipitate from the l-arabinose come out as .1746 gm. and .1777 gm. which agree remarkably well with the values obtained for pure d-arabinose.

D. Results of Determination of d-Lyxose by the Standard Procedure

As apparatus differences are one of the causes of variation of results between different observers the fact that satisfactory check results were obtained by running duplicate samples was taken as a basis that my technique was not at fault and so it was decided that runs would next be made on samples of d-lyxose. Figure 4 shows the remarkable closeness in results obtained by Smith (II) and myself. The only difference noted is a constant one which can be assumed to be an apparatus error. The table on the next page compares the actual results obtained by the two observers.

Grams of d-lyxose	Weight of precipitate (grams)	
	Smith	Gutttag
.0100	.0080	.0049
.0100	-	.0036
.0200	.0173	-
.0200	.0172	-
.0300	.0264	-
.0500	.0443	.0401
.0500	-	.0393
.0700	.0604	-
.1000	.0915	.0845
.1000	.0911	.0855
.1500	.1295	-
.2000	.1749	-
.2000	.1729	-
.3000	.2598	.2568
.3000	-	.2534

From these values Smith and Gutttag were able to determine the constants in the equation $A = a + bp$. The constants were obtained in the following manner. For a weight of sample A_1 the appropriate weight of precipitate p_1 was chosen giving an equation with a and b as unknowns. Then a second equation was set up with a weight of sample A_2 and the corresponding weight of precipitate p_2 . By solving the two simultaneous equations the constants a and b were found. The values of

a and b chosen were averages obtained from using several different pairs of simultaneous equations.

From his values Smith obtained the equation

$$A = 0.0044 + 1.142p$$

Guttag obtained from his values the equation

$$A = 0.0052 + 1.133p$$

E. Results of Determination of d-Ribose by the Standard Procedure

1. Preparation of Crystalline Ribose

We were fortunate in obtaining a sample of sirupy d-ribose from Merck and Company of Rahway, N. J. We worked up samples of this sirup by the following procedure which is a modification of the one used by Steiger (XXI)

To ten grams of p-bromphenylhydrazine hydrochloride were added seventy five cc. of water. Then about two and one half grams of sodium hydroxide were added. The sodium hydroxide was slightly more than the theoretical amount of base needed to neutralize the hydrochloric acid present. The p-bromphenylhydrazine which was soluble in the water was gradually precipitated as the free acid present was neutralized by addition of base. The mixture was then shaken up with chloroform which is a good solvent for the free base. The chloroform solution of the free base was next boiled with decolorizing carbon to remove most of the red coloring matter present and then it was filtered through a carbon filter. The chloroform was distilled off under reduced pressure in an apparatus illustrated in Diagram B.

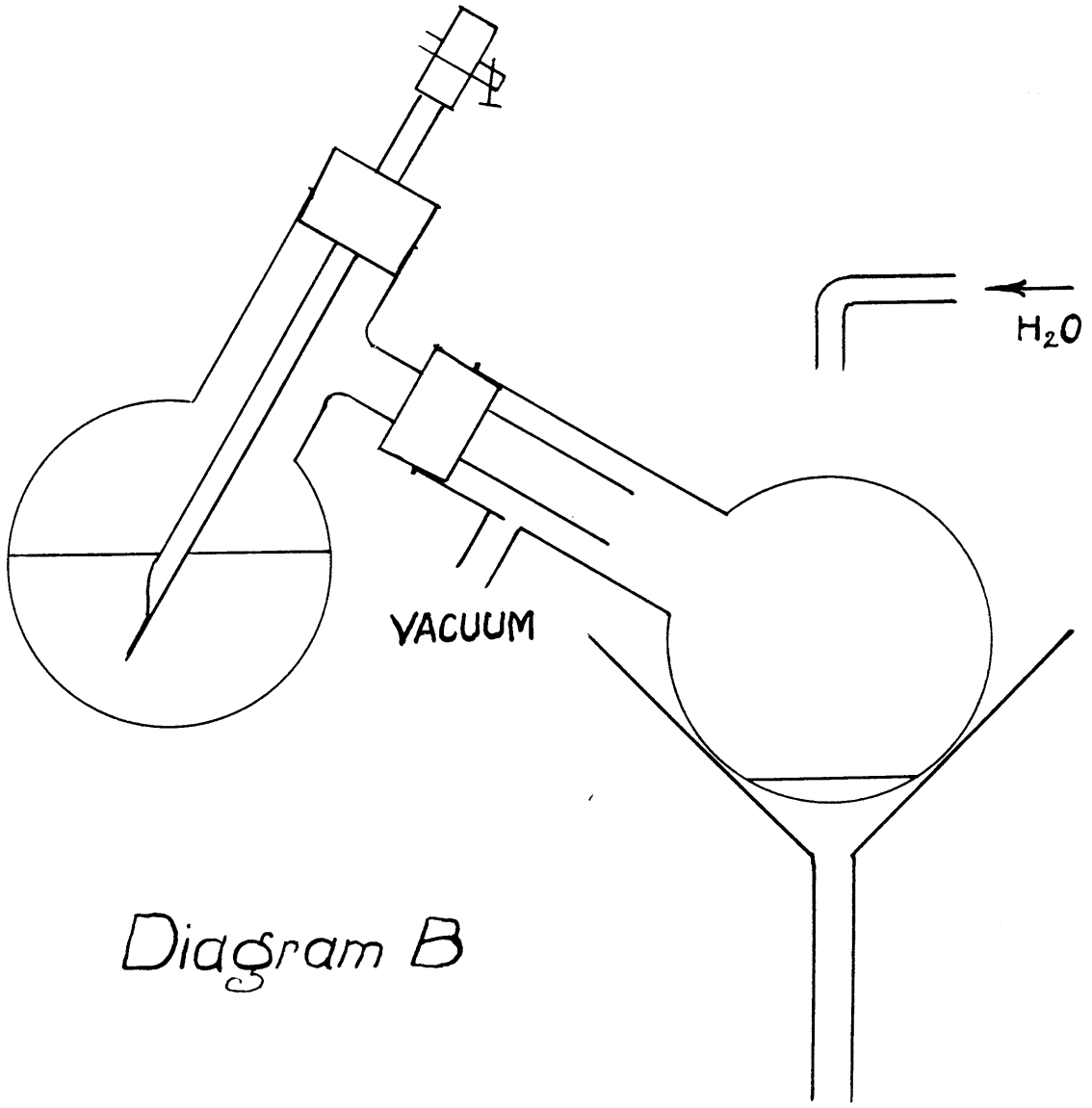

Diagram B

The p-bromphenylhydrazine was left behind in the distilling flask.

Ten cc. of methyl alcohol were added to eight grams of ribose sirup (a quantity theoretically equivalent to ten grams of p-bromphenylhydrazine). Ten cc. of methyl alcohol were also added to the p-bromphenylhydrazine. Then the ribose solution was poured into the bromphenylhydrazine-methyl alcohol mixture and a drop of glacial acetic acid added as a catalyst. The mixture was heated on the steam bath for three minutes, at which time complete solution had occurred, and the solution was allowed to stand overnight. The ribose bromphenylhydrazone had crystallized out as a light yellow precipitate. The liquid was filtered off and then the precipitate was washed first with alcohol and next with ether. The precipitate weighed about twelve grams (75% of theoretical).

The ribose bromphenylhydrazone was cleaved by using benzaldehyde in a manner similar to that described by Reichstein (XXII). To the ribose bromphenylhydrazone were added 350 cc. of boiling water. A light green fluorescent solution was formed. After fifteen minutes three cc. of benzaldehyde were added and a light yellow precipitate was formed. Fifteen minutes later three more cc. of benzaldehyde were added and allowed to react for fifteen minutes. In all the benzaldehyde added amounted to one and one half the amount theoretically needed for cleavage.

The ribose solution was then treated several times with decolorizing carbon and filtered through a carbon filter. After the final treatment the solution was pale green in color. The solution was next evaporated to about half its initial volume in a vacuum and then extracted eight times with small portions of chloroform. After the eighth extraction there was no longer a test for solids in the chloroform.

After the chloroform extractions the ribose solution was distilled in a vacuum in the apparatus shown in Diagram B. The distilling flask was placed on a water bath maintained at about 40°C. When all the water had been distilled off the ribose was left behind as a thick sirup. This sirup was taken up in a small amount of absolute ethyl alcohol and the alcohol was allowed to evaporate off in a desiccator. Despite the introduction of seed crystals the ribose came out in a sirupy form when all the alcohol had evaporated off.

A second sample of eight grams of impure ribose sirup was worked up according to the preceding procedure. In this case a yield of 41% of theoretical of the p-bromphenylhydrazone was obtained.

After several unsuccessful attempts to crystallize the ribose from absolute alcohol (thick sirups resulting in every case) the two samples of ribose were taken up separately in absolute ether. This proved to be a successful

crystallizing medium, the ribose coming out as a light yellow precipitate. The second sample of ribose crystals was washed with eighty five cc. of an equal mixture of absolute alcohol and absolute ether. The crystalline ribose thus obtained weighed 0.851 grams (10.6% of theoretical). The ribose crystals were found to have an $[\alpha]_D^{20}$ of -19.6° compared with an $[\alpha]_D^{20}$ -23.7° for pure ribose. The first sample of ribose was then dissolved in absolute alcohol and by a careful dropwise addition of ether a precipitate freed from impurities was obtained. This precipitate was white in color. It was separated from the mother liquor by filtration and washed with a two to one ether-alcohol mixture. The ribose attained at this stage was assumed to be pure enough to conduct experiments with it. This pure ribose weighed 0.55 grams.

2. Results Obtained with the Standard Procedure

Because of the limited time available it was decided that it would be best to go ahead and work with the small sample of pure crystalline ribose obtained and get as many individual values with it as possible. At the same time it was hoped that duplicate runs could be made later but this turned out to be impossible to do.

Therefore one portion of the d-ribose was used in the 100% method of analysis (to be described later in this thesis) and the rest was utilized in obtaining results by

the standard phloroglucinol procedure. Samples were taken as far apart in weight as the amount of material at hand allowed. Although no duplicate runs were made it was felt that if a straight line graph was obtained by plotting the points obtained this would be sufficient check that the results were accurate. Such a graph was arrived at. (Figure 6) The table of results is given below.

grams of d-ribose	weight of precipitate
.0512	.0499
.1010	.0980
.1500	.1461

These results were used to find the constants in the equation $A = a + bp$ for d-ribose. The manner of deriving these constants was explained when the similar constants were derived for d-lyxose. (This thesis page 23) The equation obtained was

$$A = 0.0036 + 1.027p$$

F. Conclusions on the Standard Phloroglucinol Procedure

With the plotting of the graph for d-ribose graphs have now been obtained for all four pentoses. The differences in the graphs for the pentoses are clearly shown in Figure 7. By considering Figure 7 the effects of the presence of d-ribose or d-lyxose in a mixture of pentoses can be determined. Previously in pentose determinations these possible effects have been neglected.

Figure 6

Phloroglucinol Precipitate vs. Ribose

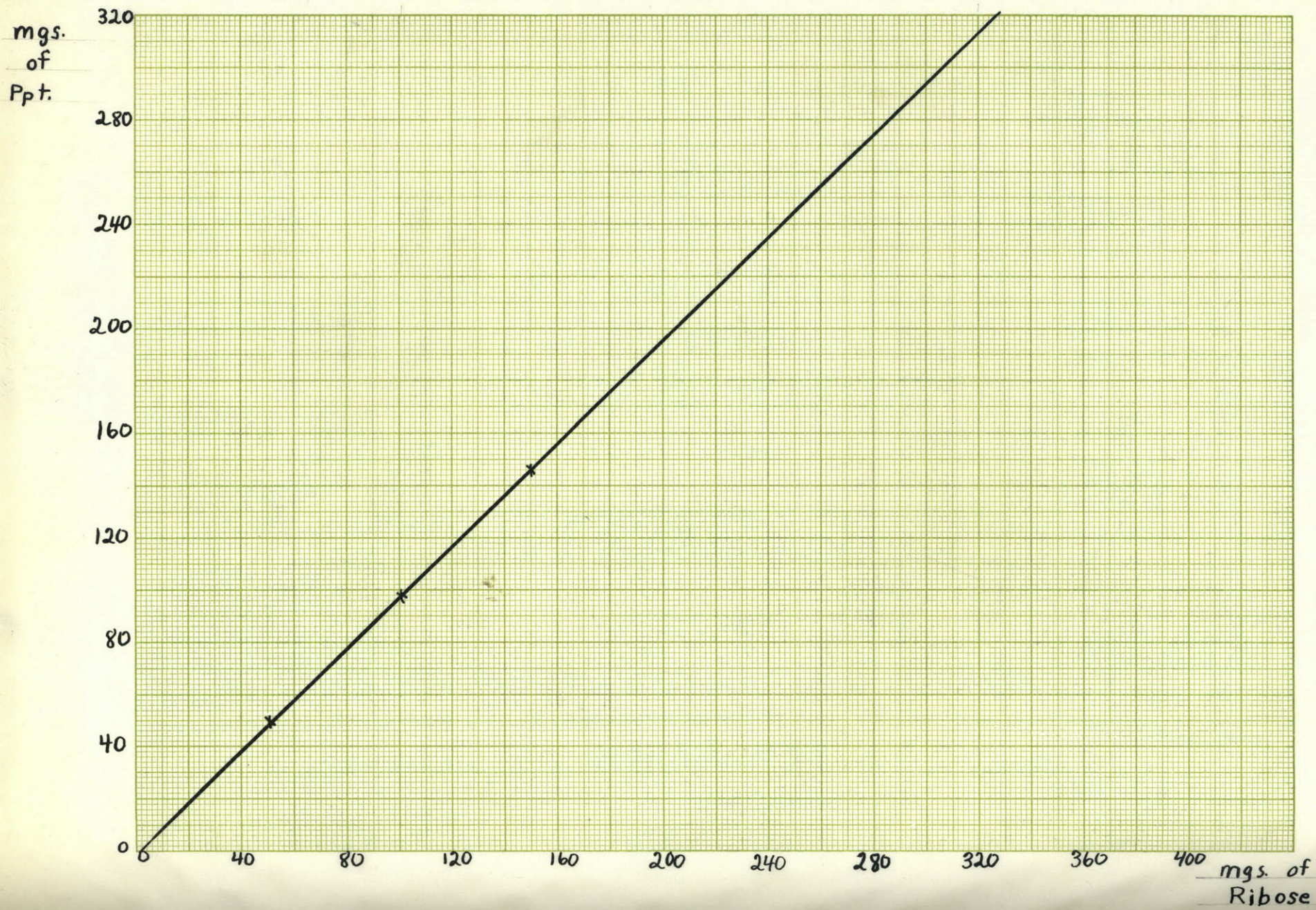
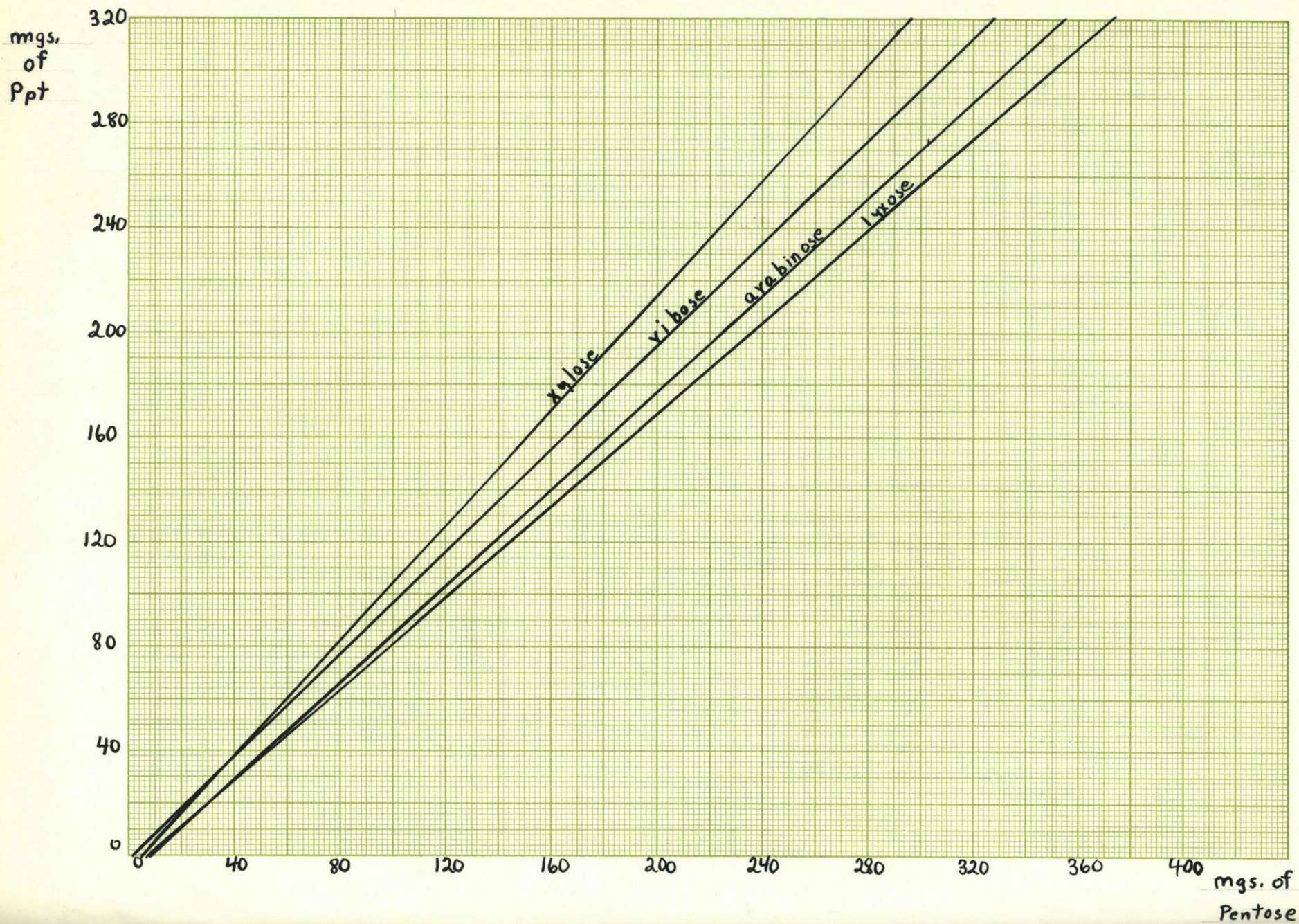

Figure 7
Phloroglucinol Precipitate vs. Pentose



The following equations have been determined for the four pentoses and for an artificial body labeled "pentose". This last is supposed to represent the equation for the normal mixture of arabinose and xylose as they occur in a natural sample.

$$\text{xylose} \quad A = 0.0053 + 0.911p$$

$$\text{ribose} \quad A = 0.0036 + 1.027p$$

$$\text{arabinose} \quad A = 0.0076 + 1.089p$$

$$\text{lyxose} \quad A = 0.0052 + 1.133p$$

$$\text{"pentose"} \quad A = 0.0052 + 1.007p$$

These equations show even more clearly than the graphs the effect of ribose or lyxose on pentose determinations. Ribose, if present, will throw off the value of "pentose" by several per cent while lyxose, if present in large amount, can throw this figure off by over 10%.

G. Steam Distillation Procedure

1. Preparation of Additional Reagents

Pure potassium dichromate was dried in the oven at 105°C. overnight. A carefully weighed sample (1.1623 gm.) was dissolved in water in a 100 cc. graduated flask. The solution was then made up to the mark.

Sodium thiosulfate ($\text{Na}_2\text{S}_2\text{O}_3 \cdot 5 \text{H}_2\text{O}$, 84.6 gm.) was dissolved in seven liters of water. This solution was then standardized against the potassium dichromate solution. To ten cc. of the dichromate were added five cc. of 12%

hydrochloric acid and one gram of potassium iodide. Then the thiosulfate solution was titrated against the dichromate using starch as an indicator. The normality of the thiosulfate turned out to be 0.04841 N.

Potassium bromate-potassium bromide solution was made by dissolving 9.8 grams of potassium bromate and 70.7 grams of potassium bromide in seven liters of water. This solution was then standardized against the thiosulfate by adding potassium iodide in acid solution to the bromate-bromide solution. Starch was used as an indicator. The bromate-bromide solution was 0.04875 N. One cc. of bromate-bromide solution was equivalent to 1.007 cc. of the thiosulfate solution.

2. Test of Technique

Test titrations were made by using pure furfuraldehyde (Boiling Point 159-159.6°). One cc. of furfural was added to thirty cc. of standard 12% hydrochloric acid and the mixture diluted to exactly 100 cc. in order to duplicate as nearly as possible the experiments later to be carried out on furfural obtained from lyxose and ribose. To ten cc. portions of this mixture were added seventy five cc. of bromate-bromide solution and the resulting solution was allowed to stand for exactly five minutes at 0°C. Then potassium iodide was added and after this had been allowed to act for about seven minutes at 0°C. the iodine liberated (corresponding to the excess bromate) was titrated against

the thiosulfate with starch as an indicator. Because very good check results were obtained it was decided that we would proceed with the work on the steam distillation of furfural obtained by the decomposition of d-lyxose in acid solution.

3. Steam Distillation of Furfural from d-Lyxose

The procedure used was essentially that of Hughes and Acree. (XIV, XVIII) To a .1000 gram sample (a size of sample which they claim gives the best results) were added 100 cc. of 12% hydrochloric acid and twenty grams of sodium chloride. The salt added corresponds fairly closely with the amount needed to saturate hydrochloric acid. The distillation was carried out in the apparatus shown in Photographs 1 and 2. The difference between this apparatus and that shown in Diagram A which was used in the work on the standard procedure lies in the fact that arrangement has been made to admit steam into the distilling flask by sealing a glass tube into the distilling flask. This type of distilling flask is shown in Diagram A₂. The glass tube was connected by a rubber tube to a pressure cooker which was used to generate steam. The amount of steam admitted to the distilling flask was controlled by regulating the bleed off valve A in Photographs 1 and 2. Unlike the runs with the standard procedure in which initially the distilling flask was heated by a bunsen burner in all the runs with the steam distillation procedure the distilling flask was heated by an electric cone heater.

Photograph 1

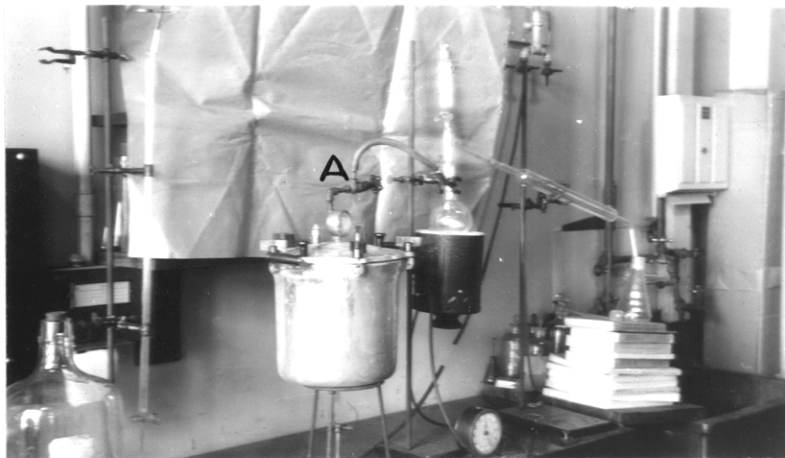

Photograph 2

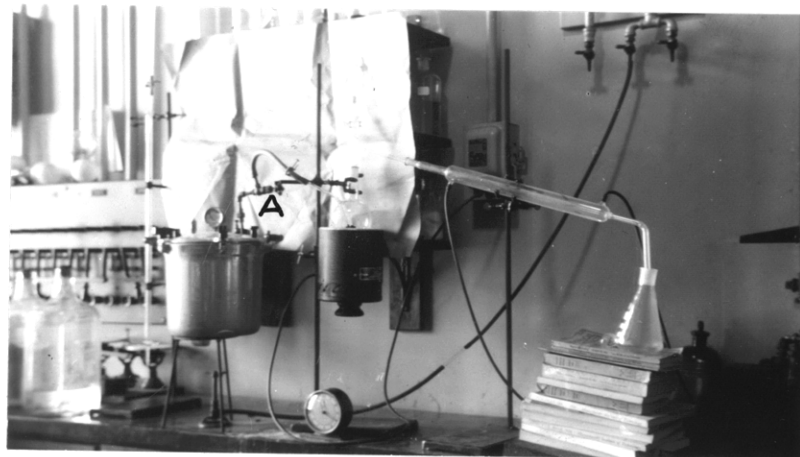

Distillation was carried out at a rate as close to 400 cc. an hour as possible. The volume of liquid in the distilling flask was kept between seventy and one hundred cc. by adding thirty cc. of 12% hydrochloric acid every ten or fifteen minutes. The distillate was collected in 500 cc. erlenmeyer flasks.

At the start of the runs determination of the furfural liberated from the pentose was made at half hour intervals. As the amount of furfural set free became smaller hour intervals and eventually two hour intervals were used. Distillation was continued until the distillate no longer gave a test for furfuraldehyde with aniline acetate reagent.

The distillate collected in each time interval was poured into a liter erlenmeyer flask which was equipped with a ground glass stopper. The flask was placed in an ice bath and allowed to cool to as near 0°C. as possible. Then twenty five cc. of bromate-bromide solution were added by means of a pipette and the bromate-bromide allowed to act for exactly five minutes. Next one gram of potassium iodide was added and this was allowed to act for from five to ten minutes. The iodine set free was titrated against standard thiosulfate using starch as an indicator. The iodine set free corresponds to the excess bromate used. As the total bromate used was known the bromate equivalent to the furfural present could be determined and thus the per cent yield of furfural from d-lyxose in each time inter-

val could be found as well as the total yield of furfural from d-lyxose.

Two runs were made with d-lyxose. The first one had to be stopped after six and one half hours because all the water had been removed from the pressure cooker. The second determination was run to completion and 100% yields of furfuraldehyde were obtained from d-lyxose in about ten and one half hours of distillation. The per cent yield of furfural at the various times of determination for the first and second runs gave very good checks on values up to six hours. The curve obtained for the steam distillation of furfural from d-lyxose is shown in Figure 5. It can be compared with the curves obtained for d-xylose, d-arabinose and d-rhamnose by Acree and Hughes. (Figure 3)

Although lyxose required a relatively long time for all the furfural to be formed it should be noted that the amount obtained in the early stages is relatively high. This is as would be expected from the results obtained by the standard phloroglucinol procedure. In the standard procedure the furfural came over very quickly from the decomposition of the lyxose in the distilling flask but low yields of the precipitate were obtained. The fact that the furfural came over quickly is the same phenomenon exhibited by the large initial yield of furfural in the steam distillation. The fact that low results were obtained in the standard procedure is the same phenomenon as the

Figure 5

Yield of Furfural vs. Time of Distillation

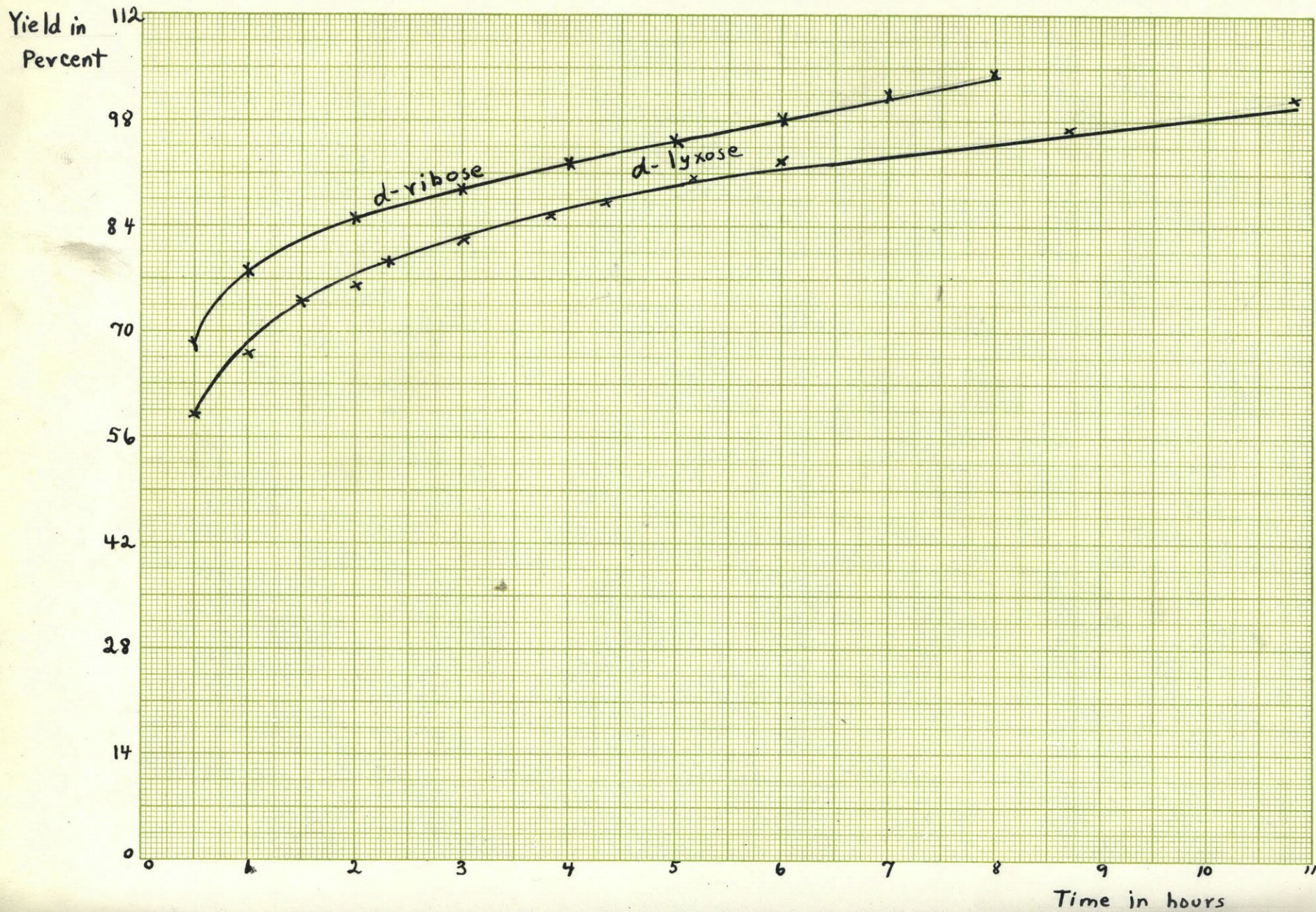

great length of time required to obtain 100% yields of furfuraldehyde.

4. Calculation of the Order of Reaction for the Production of Furfural from d-Lyxose by a Steam Distillation

It was believed that lyxose decomposed to form furfural by a first order reaction depending only on the weight of lyxose present at any time. However, this was proved to be erroneous as the following data show.

The integrated equation for a first order reaction is

$$2.303 \log \frac{C_0}{C_0 - Z} = kt$$

C_0 is the amount of sample at time 0
 Z is the amount of sample which has reacted at any time t

k is the constant for the reaction

First run of d-lyxose		Second run of d-lyxose	
Time	Value of k	Time	Value of k
1/2 hour	.0301	2 hrs. 20 min.	.0129
1 hour	.0185	4 hrs. 22 min.	.0087
1 1/2 hrs.	.0152	6 hrs. 30 min.	.0066
2 hours	.0139	8 hrs. 41 min.	.0068
3 hours	.0096		
3 hrs. 50 min.	.0084		
5 hrs. 10 min.	.0076		
6 hours	.0074		

Only slightly better results were obtained by using the following formula for a second order reaction:

$$\frac{Z}{(C_0 - Z)(C_0)} = kt$$

First run of d-lyxose		Second run of d-lyxose	
Time	Value of k	Time	Value of k
1/2 hour	.0365	2 hrs. 20 min.	.0206
1 hour	.0253	4 hrs. 22 min.	.0193
1 1/2 hrs.	.0256	6 hrs. 30 min.	.0235
2 hours	.0200	8 hrs. 41 min.	.0466
3 hours	.0190		
3 hrs. 50 min.	.0189		
5 hrs. 10 min.	.0226		
6 hours	.0272		

Calculated as a third order reaction by the following equation the results were worse than for either a first or second order reaction.

$$\frac{1}{(1-Z)^2} - \frac{1}{C_0^2} = kt$$

First run of d-lyxose		Second run of d-lyxose	
Time	Value of k	Time	Value of k
1/2 hour	.0928	2 hrs. 20 min.	.0897
1 hour	.0765	4 hrs. 22 min.	.1255
1 1/2 hrs.	.0862	6 hrs. 30 min.	.2490
2 hours	.0774	8 hrs. 41 min.	1.302
3 hours	.0934		
3 hrs. 50 min.	.1108		
5 hrs. 10 min.	.1916		
6 hours	.3136		

These results show that the reaction is not a simple one but of a more complex nature.

5. Test Run on d-Xylose

A run was made on a .1000 gram sample of d-xylose in order to further check up on the accuracy of the method. A graph very similar to the one of Hughes and Acree (Figure 3) was obtained. The final yield was only about 98.5% of the theoretical yield. This slightly low yield was explained by the fact that the rate of distillation for the first half hour was slow. (One of the difficulties with the steam distillation procedure is that at the beginning, when it is of the utmost importance that the rate be just right, the rate of distillation is not the desired one. Usually it takes fifteen minutes to half an hour to adjust the rate to 400 cc. an hour despite the fact that the apparatus may have been satisfactorily adjusted for the immediately previous run.)

6. Results with d-Ribose

A rapid steam distillation was carried out on a .1000 gram sample of d-ribose. Although not enough sample was available to run the distillation in duplicate a smooth curve was obtained and it appeared that a satisfactory run was made. By looking at Figure 5 it can be seen that furfural came over from the decomposition of d-ribose at a higher initial rate and more rapidly than from any other

pentose or methylpentose except d-xylose. This is what might have been suspected from the results obtained in the standard procedure. In that procedure the furfural came over very quickly and in a larger amount than from any other sugar except xylose.

It should be noted that the final results gave a 104% yield of furfural from ribose. The explanation of this is given below.

A blank run was made under conditions identical with those used in the regular steam distillations except that no pentose was placed in the distillation flask. It was discovered that there was a blank error of .0188 milliequivalents for each titration. This would account for the yield of ribose in excess of 100%. However, Acree and Hughes make no mention of a blank error in their runs. It is probable that this error is introduced only when the amount of furfural present in the distillate is extremely small.

SUMMARY

The following results have been accomplished by this thesis:

1. A check has been made on the work done on d-lyxose with the standard procedure by Smith. The check was very satisfactory. A graph and equation for the determination of the weight of lyxose in a sample from a known weight of phloroglucinol precipitate was obtained.
2. New work has been done on obtaining 100% yields of furfural from d-lyxose. Although the results appear satisfactory further investigation should be made of the possible effect of a blank error.
3. New work has been done on the standard procedure for pentose determination with d-ribose. A graph and equation for the determination of the weight of ribose in a sample from a known weight of phloroglucinol precipitate was obtained. Although the results obtained appear to be satisfactory they are not complete enough and a continuation of the work should be made in this direction.
4. New work has been done on obtaining 100% yields of furfuraldehyde from d-ribose. Although a smooth curve was obtained the fact that the yield was 104% and the fact that a blank error is known to be present warrant further investigation of this procedure.

The titration error can be virtually eliminated by making only one titration after all the furfural has come over into the collecting flasks. In this way 100% yields of furfural from pentoses may be assured. However, if this procedure is adopted no graph of the course of the reaction could be made and there would be no way of distinguishing how much of each of the four different pentoses was present.

5. For the first data has been obtained on the production of furfural from all the pentoses and so we can now find out the limits of accuracy of pentose determinations. Data has been obtained on the four pentoses for two procedures, the standard phloroglucinol procedure and the rapid steam distillation procedure.

6. The standard procedure is still the best one for routine analysis. It is simpler to carry out than the 100% method of a rapid steam distillation, it does not require as much skill to carry out and it can be done in a much shorter time of actual work. The fact that as much as thirteen or fourteen hours of steady work may be required in carrying out the 100% method alone will prevent it from being adopted for routine analysis.

- I F. Micheel---"Chemie der Zucker und Polysaccharide" (1939)
- II M. E. Smith---Bachelor's Thesis M. I. T. (1939)
- III C. Doree---"The Methods of Cellulose Chemistry" (1933)
- IV Nelson and Cretcher---J. Amer. Chem. Soc. 51, 1914 (1929)
- V A. D. Dickson, H. Otterson, K. P. Link---J. Amer. Chem.
Soc. 52, 775 (1930)
- VI E. Kröber---J. Landw. 48, 357 (1900)
- VII B. Tollens---"Abderhalden's Arbeitsmethoden" II, 130 (1909)
- VIII Norris---Biochem J. 30, 2146 (1936)
- IX N. C. Pervier and R. A. Gortner---Ind. Eng. Chem.
15, 1167 (1923)
- X R. Jager and E. Ungar---Ber. 36, 1222 (1903); Z. Untersuch
Lebensm. page 66 (1933)
- XI W. Gerisch---Cellulosechem. 6, 6 and 81 (1925)
- XII S. F. Acree---Bur. Standards Jl. Research 8, 29 (1932)
- XIII C. A. Browne---"Handbook of Sugar Analysis (1912)
- XIV E. E. Hughes and S. F. Acree---B. S. J. Research
21, 327 (1938)
- XV Zavodskoya---Lab. 6, 558 (1937) (Reported by Smith)
- XVI Brodilnaya---Prom. 11 No. 5, 26 (1934) (Reported by Smith)
- XVII H. R. Ling and D. R. Nanji---Biochem. J. 15, 466 (1921)
- XVIII Hughes and Acree---B. S. J. Research 23, 293 (1939)
- XIX Hughes and Acree---Ind. Eng. Chem., Anal. Ed. 9, 318 (1937)
- XX W. Mayer and B. Tollens---J. Landw. 55, 261 (1907)
- XXI M. Steiger---Helv. Chim. Acta 19, 189 (1936)
- XXII T. Reichstein---Helv. 17, 996 (1934)