

VII. ATOMIC BEAMS*

Prof. J. R. Zacharias	D. D. Babb	D. S. Edmonds, Jr.
Prof. J. G. King †	V. J. Bates	E. P. Hilar
Prof. G. W. Stroke †	H. H. Brown, Jr.	C. L. Searle
Dr. R. F. C. Vessot	A. W. Crooke	R. Weiss
	B. DiBartolo	

A. A SMALL TITANIUM ION PUMP (TIP)

1. Introduction

In a recent article on molecular-beam techniques (1) we wrote, "It may well turn out that the so-called Evapor-Ion Pump may so supplement the available devices that the present discussion will be obsolete by the time it appears in print." This statement has proved correct, and we wish to describe a small, simple, titanium-getter ion pump (TIP) based on the Evapor-Ion principle (2). Such devices are extraordinarily useful and, in our opinion, will ultimately have an important influence on both research and commercial applications of high vacuum.

2. Principle of Operation

The pumping action of vacuum gauges, in which ions are driven into a collector plate, and thus removed from general circulation, and the gettering action of freshly evaporated metal films are combined in the TIP by making the collector of a conventional triode ion gauge an evaporated film of titanium. Figure VII-1 is a scale drawing of the TIP. Several ways of making the titanium filament were tried, among them twisting together three 0.010-inch tungsten wires and three 0.010-inch titanium wires and winding a helix from the cable so formed. After the first flash, the titanium collects in the interstices between the tungsten wires, so that many subsequent flashes are possible. The electron filament is made of 0.010-inch thoriated tungsten. The grid is of 0.020-inch molybdenum. The titanium connection is made of wire fused to a patch of platinum. The dimensions are not to be taken too seriously – experience indicates that wide latitude is permissible.

3. Performance

We have been so delighted with the TIP that we have been content to use it without trying to understand its action in detail, nor have we obtained exhaustive data under different operating conditions. Some data that exhibit the performance that can be

*This research was supported in part by Purchase Order DDL-B187 with Lincoln Laboratory, which is supported by the Department of the Army, the Department of the Navy, and the Department of the Air Force under Contract AF19(122)-458 with M. I. T.

†Also of the Department of Physics, Graduate School, Boston University.

(VII. ATOMIC BEAMS)

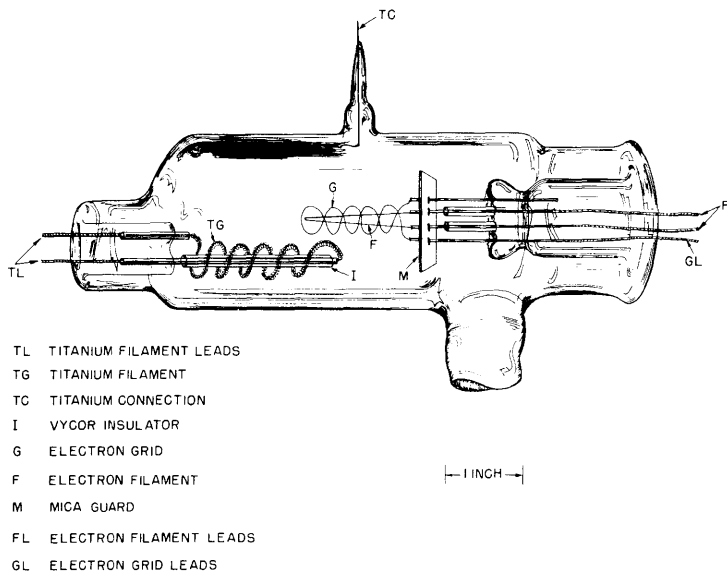

Fig. VII-1. Titanium ion pump.

expected were taken with the apparatus shown in Fig. VII-2. The TIP is connected to an ionization gauge of the Bayard-Alpert type (3) through a valve consisting of a 7/8 inch (diameter) magnetic stainless steel ball that can be lowered into a ground seat with a magnet. As part of another experiment, an appendage with a tapered ground joint sealed only on the outside with Myvawax had been placed on the gauge side of the valve. The whole assembly was sealed off at approximately 10^{-5} mm Hg with no baking at all. The titanium filament was heated until a barely opaque deposit was formed in the TIP bulb, and the apparatus was used for qualitative demonstrations for several months, during which a pressure of 2×10^{-8} mm Hg was consistently indicated by the ionization gauge. The data plotted in Fig. VII-3 were taken as follows. The ball valve was left closed overnight with the gauge off to allow gas to accumulate. When the gauge was turned on the next morning, the pressure rose in approximately 1 hour from approximately 10^{-5} mm Hg to approximately 10^{-4} mm Hg as the adsorbed gas in the gauge was driven off by the heat of the filament. Opening the valve produced the dramatic effect shown in Fig. VII-3.

At A on curve I the ion gauge was turned on with the ball valve still shut. When the pressure had risen to a steady value, the valve was opened at B. The pressure then drops by virtue only of getter pumping until C, when a 5-ma electron current was turned on in the TIP, whereupon more pumping took place. The data for curve II were taken under the same conditions except that the 5-ma electron current was on at the beginning of the experiment. The data for curve III were taken one month

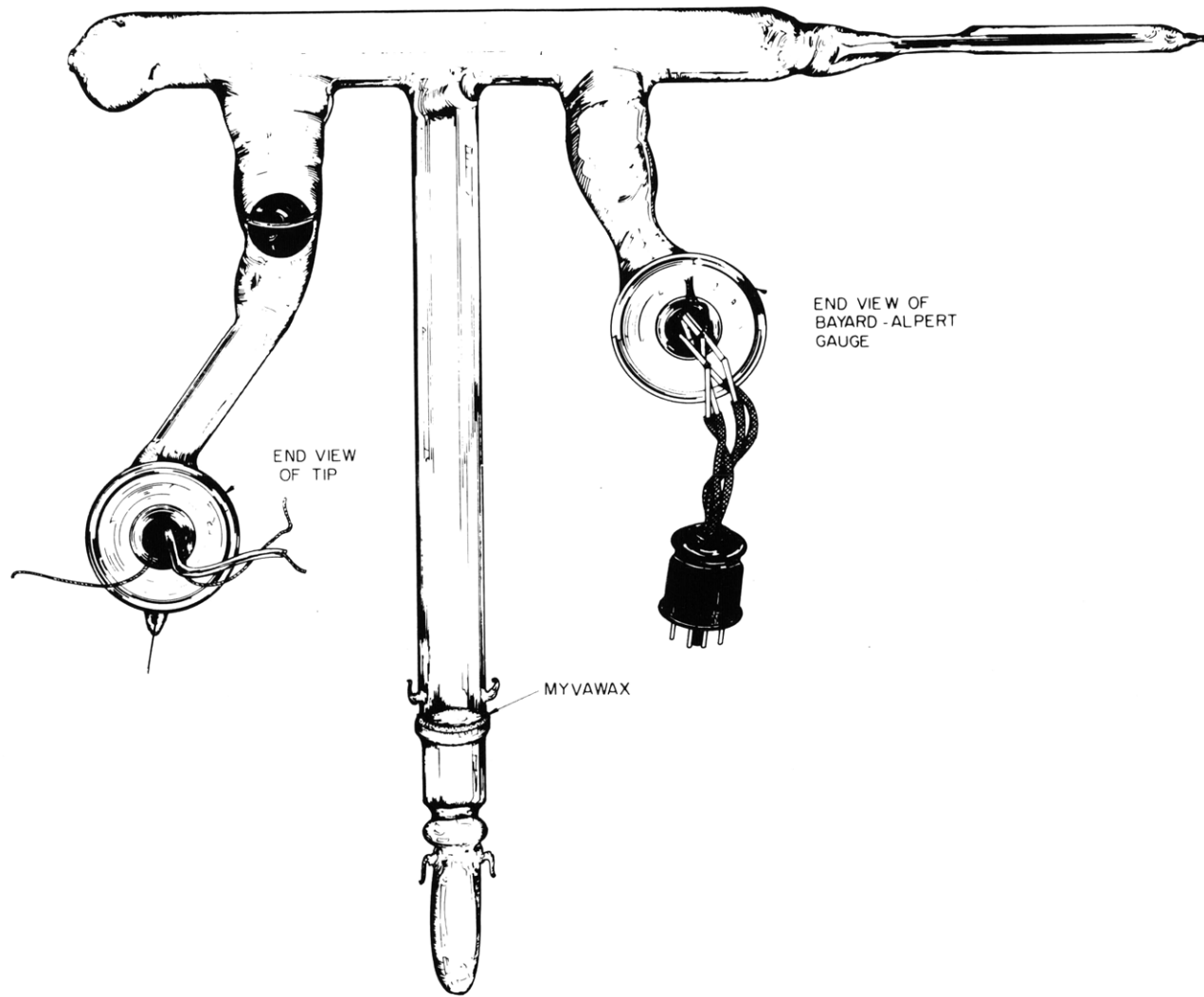

Fig. VII-2. Titanium ion pump test apparatus.

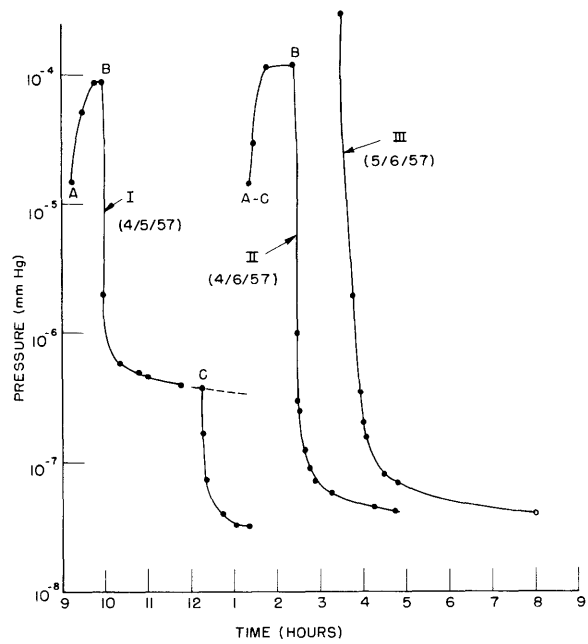

Fig. VII-3. Titanium ion pump performance.

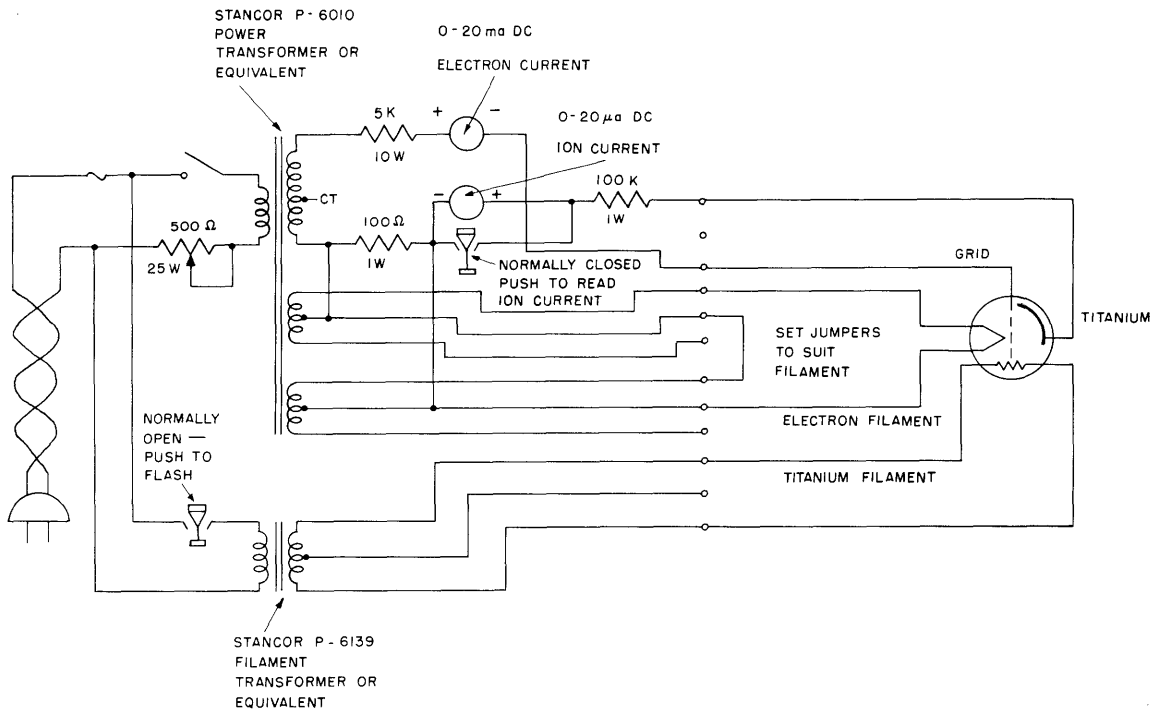

Fig. VII-4. Titanium ion pump circuit.

later. In all cases the pressure continued to fall to a final value between 1 and 2×10^{-8} mm Hg, which was attained within 12 hours.

The electrons were accelerated by making the grid 250 volts positive with respect to the filament, the temperature of which was adjusted to give the desired emission. A return path for the ion current to the titanium was provided by an external connection to the filament. Making the titanium as much as 300 volts negative with respect to the filament had a negligible effect on performance.

Although conventional dc power supplies were used in these tests, the TIP worked equally well on ac from a small power transformer with appropriate filament and high-voltage windings connected as shown in Fig. VII-4. Demonstrations of this device by closing and opening the ball valve to show the gas accumulation with subsequent pumping were performed scores of times, for our own pleasure and for visitors, with results qualitatively like that of the graph. Curve III of Fig. VII-3 (taken one month later than curves I and II) shows little change in performance. The "leak" in the system seemed to remain constant for months and the ultimate vacuum always stayed the same -- between 1 and 2×10^{-8} mm Hg.

4. Conclusion

1. From repeated measurements of the pressure rise when the ball valve is closed (10^{-4} mm Hg in 16 hours) and the estimated volume of the system (0.5 liter) we find that approximately 3×10^{10} atoms/sec are leaking into and/or are evolved in the system. Most of this gas did not condense at liquid-nitrogen temperature, since the pressure was only slightly reduced when the appendage shown in Fig. VII-2 was cooled. The equilibrium pressure maintained by the TIP with 5 ma of electron emission in the presence of this leak is near 10^{-8} mm Hg.

2. The equilibrium pressure has not changed significantly during a period of several months since the evaporation of the titanium, so that approximately 2×10^{17} atoms have been disposed of by the pump. Since the area of evaporated titanium film is 150 cm^2 , and there are 10^{17} titanium atoms per monolayer in the film, there must be some depth effects, and we might expect the pumping action to continue for a considerably longer time.

3. The importance of the ionization produced by the electrons, particularly in reducing the time required to reach the lowest pressures that were attained, is seen clearly from Fig. VII-3. Other rough experiments indicate that ionization plays an increasingly important role relative to pure getter action as the leak rate increases.

The TIP has nearly the same grid-filament geometry as our standard triode ion gauge. It is interesting to note that if it had the same constant $K = \frac{i_{\text{pos}}}{i_{\text{neg}}} \frac{1}{p} = 15 \text{ mm}^{-1}$, then, at 6×10^{-8} mm Hg, the number of ions formed per second with 5 ma of electron

(VII. ATOMIC BEAMS)

current would just equal the leak rate. Attempts were made to measure the ion current, but the ohmic leakage currents proved excessive. Newer designs, as yet untried, will be arranged to minimize ohmic leakage, and will include a form of Bayard-Alpert gauge in the TIP envelope.

4. Although the performance of the TIP at both higher and lower leak rates and pressures has not been investigated, the TIP in its present form bridges the gap between ordinary static and kinetic vacuum systems and provides a clean vacuum with a minimum of accessory equipment and utilities.

5. The results of a number of experiments indicate that it is not necessary to start the TIP at 10^{-5} mm Hg but that a pressure of 10^{-3} mm Hg is adequate. We believe that by using a water aspirator trapped with dry ice or by flushing the system with a vapor (e.g., carbon tetrachloride) that is then frozen out with dry ice, an adequate initial vacuum for the TIP might be provided. Our preliminary trials of these methods failed because sufficient heat could not be supplied to vaporize the titanium without burning out the tungsten heater, which was of an earlier design than that shown in Fig. VII-1 and required much larger currents. More than a dozen TIP's, with minor variations in design, have been used and none has failed to work essentially as described above. The prospective user should be cautioned against trying to use a small TIP with leak rates of, say, 10^{13} atoms/second, which may not seem large because, customarily, they are handled readily enough by diffusion pumps, nor should he mistake the low vapor pressure of greases and rubber O-rings for a low leak rate. This last word of caution may seem superfluous but several workers who tried these simple devices were disappointed in their performance for just this reason. For example, one should not substitute a conventional stopcock for the ball valve shown in Fig. VII-2.

J. G. King, J. R. Zacharias

References

1. J. G. King and J. R. Zacharias, Some applications and techniques of molecular beams, *Advances in Electronics and Electron Physics*, Vol. VIII (Academic Press, Inc., New York, 1956), p. 80.
2. Data Sheet No. 6-140, Consolidated Electrodynamics Corporation, Rochester, New York, n.d.
3. D. Alpert, *J. Appl. Phys.* 24, 860 (1953).

B. CRYSTAL OVEN TEMPERATURE CONTROL

A temperature control system with a high-temperature-coefficient quartz crystal as the sensing element was discussed in the Quarterly Progress Report of October 15, 1956, page 51. The design of such a system for a crystal oven (1) reveals

several important limitations, the most significant of which is the complex circuitry required. The minimum value of closed-loop, ambient-to-oven-temperature attenuation, for a crystal-thermometer control system in which a five-hour time constant oven and both phase-detector and frequency-discriminator feedback are used, was approximately 90 db. This minimum occurred at a frequency of approximately 10 cycles per day. The system was not built, since an equivalent, or better, attenuation could be obtained by using a resistance thermometer in a two-stage oven, with less complex circuitry (2).

The sensitivity of the temperature control, when a crystal thermometer is used, would be limited by the aging of the crystal. A crystal drift of 2 parts in 10^{-8} per day, and a temperature coefficient of 2 parts in $10^{-5}/^{\circ}\text{C}$, would result in an equivalent oven-temperature-error drift of 0.001°C per day. No figures are available on the aging effects in resistance wire. Thus, no comparison of the effects of aging on the resistance-thermometer and crystal-thermometer circuits could be made.

A. W. Crooke

References

1. A. W. Crooke, A crystal oven temperature control, S.M. Thesis, Department of Electrical Engineering, M.I.T., June 1957.
2. P. G. Sulzer, High stability bridge balancing oscillator, Proc. IRE 43, 701-707 (1955).