

VIII. FREQUENCY MODULATION

Prof. E. J. Baghdady
Prof. J. B. Wiesner

L. C. Bahiana
R. J. McLaughlin

G. J. Rubissow
D. D. Weiner

A. FEEDFORWARD ACROSS THE LIMITER

The effect of feedback around the limiter upon the interference rejection ability of an FM receiver has been demonstrated (1, 2). Some interesting generalizations can be achieved if a signal feedback arrangement is considered as involving fundamentally the creation of two unilateral signal paths, A and B, each of which can modify the character of the resultant impressed signal in some linear or nonlinear manner. These two signal paths are combined in the feedback arrangement by connecting the output terminals of B in series with the input terminals of A and with the source, and the input terminals of B in parallel with the output terminals of A and with the input terminals of the stage that follows the composite scheme.

An interesting variation can be introduced by connecting the input entries of A and B in parallel with each other and with the source, and connecting the output entries in series with each other and with the load. This arrangement is, in a sense, the dual of feedback, and so we call it "feedforward." Figure VIII-1 illustrates the general forms of feedback and feedforward combinations.

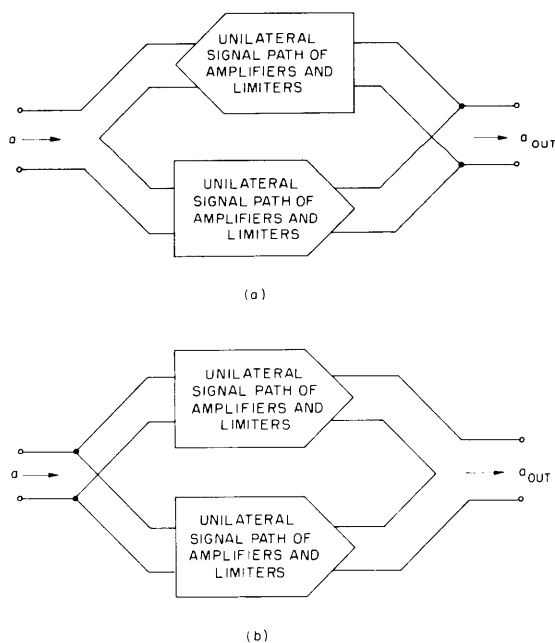

Fig. VIII-1. Combination of two signal paths for (a) feedback; (b) feedforward.

A detailed analysis of the effect of feedforward upon FM interference has been completed and a paper is being prepared for publication. The basic reasoning behind the feedforward technique starts from the fact that a chain of cascaded narrow-band limiters will process the resultant of two cochannel carriers in such a way that the predominance of the stronger signal over the weaker one is strengthened. This means that the equivalent ratio of weaker-to-stronger signal amplitude at the output of a properly designed chain of cascaded narrow-band limiters will be smaller than the corresponding ratio at the input. The greater the number of cascaded narrow-band limiters, the smaller the value of this equivalent ratio. As a result, if the two paths in Fig. VIII-1b incorporate

different numbers of narrow-band limiters, and if they are designed to offer approximately the same delay in transmitting a signal from input to output, and to have overall phase characteristics that will cause the transmitted signals to appear in phase opposition at the output, then the signal cancellations at the output can be made to suppress whichever of the two signals is undesired. The design parameter that decides which of the two signals will be captured is the ratio of path outputs. Easy control of this ratio enables the receiver to switch from the capture of the weaker signal to the capture of the stronger signal, or vice versa.

E. J. Baghdady

References

1. E. J. Baghdady, Theory of feedback around the limiter, IRE Convention Record, Part 8, 1957, pp. 176-202.
2. E. J. Baghdady, Feedback around the limiter, Quarterly Progress Report, Research Laboratory of Electronics, M.I.T., April 15, 1956, p. 42.

B. CAPTURE OF THE WEAKER SIGNAL

Various methods have been devised for achieving satisfactory capture of the weaker of two cochannel FM signals. The feedforward technique constitutes one method. A second approach depends, in principle, upon the ability of an FM demodulator (limiter-discriminator combination) to yield an output voltage whose value, after proper filtering, varies with the frequency of the stronger of two input signals. Thus a properly designed receiver signal path may be used to derive a low-frequency voltage that varies directly with the frequency of the stronger signal. If this low-frequency voltage is impressed upon the control grid of a reactance-tube circuit which forms a part of a high-Q tuned trap, it can be made to vary the resonant frequency of the trap in such a way that it introduces a dip in the over-all i-f response characteristic at the instantaneous-frequency position of the stronger signal.

A possible embodiment of this idea is shown in Fig. VIII-2. The i-f amplifier (unit 1) provides the usual i-f selectivity and gain in the FM receiver. If two signal carriers are passed simultaneously by this amplifier, then the average output voltage of the FM demodulator (unit 4) can be made to vary directly with the instantaneous frequency of the stronger signal. The output of unit 4 (after proper low-frequency filtering) can be impressed directly upon the input of a reactance tube that makes up the variable part of the tuning elements of a high-Q trap. The trap introduces a sharp dip in the response of the i-f amplifier (unit 2) that is centered approximately about the frequency of the stronger signal. This dip should decrease the amplitude of the stronger signal by a sufficient amount to enable the incipiently weaker signal to predominate. The average

(VIII. FREQUENCY MODULATION)

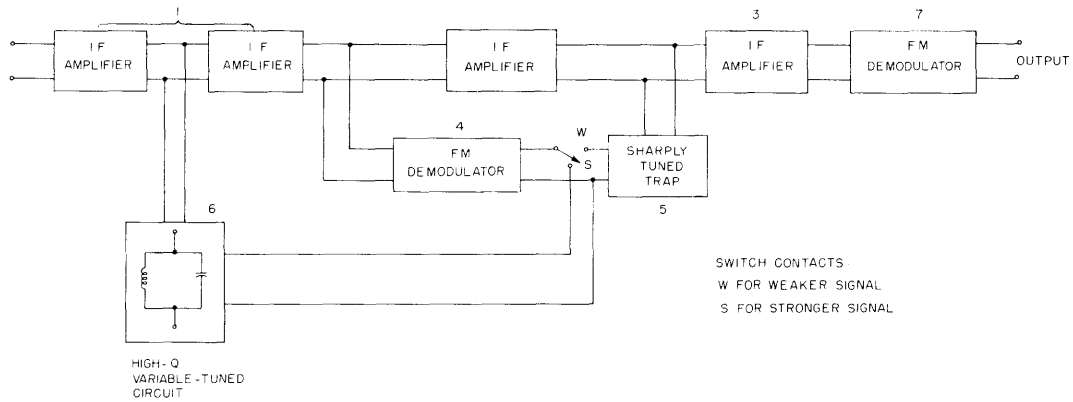

Fig. VIII-2. Variable-trap method for altering the relative amplitudes of two cochannel FM signals.

voltage at the output of the last FM demodulator (unit 7) will then vary directly with the instantaneous frequency of the weaker signal, except when both signals fall within the heavy-attenuation region of the trap dip. When this happens, the signal amplitudes will go through equality at least twice as the weaker signal sweeps across the dip. The resulting capture transitions from one signal to the other will be accompanied by corresponding bursts of distortion in the detected output waveform. (A similar difficulty is encountered when the feedforward technique is used to suppress the stronger signal.) The duration of these distortion bursts can be decreased by designing the FM demodulator (unit 7) to handle weaker-to-stronger signal-amplitude ratios that are close to unity. If the Q of the trap is sufficiently high, the dip which it introduces should simulate a sharp narrow spike that attenuates only in a frequency range that is a small fraction of the i-f bandwidth. While either signal is sufficiently strong to control the output, the disturbance at the output will be small when the frequency difference between the two signals is sufficiently small for them to lie within the trap dip simultaneously. But a very high Q trap swept by an FM signal can cause important FM transients. Nevertheless, it appears that reasonably clean capture of the weaker signal is possible over most of the modulation signal.

In the absence of interference the output of unit 4 should be disconnected from the trap. The trap should be so designed that this disconnection (by removing or adding a capacitor or an inductor) detunes the trap, and hence makes it resonate at a frequency that lies outside the desired i-f range. Alternatively, we may arrange the switch so that the trap circuit is completely disconnected from the signal path in the absence of interference.

If the stronger signal is the signal that is wanted, we can boost its amplitude by introducing a high- Q variable-tuned circuit (unit 6) whose center frequency is controlled by a reactance tube. This arrangement should help decrease the random-noise

bandwidth and improve the predominance of the stronger signal over the interference.

The distortion from capture transitions and FM transients is inherent only in the operations involved in the two schemes that have been discussed. Other methods have been devised that are free from these difficulties.

E. J. Baghdady

C. DYNAMIC TRAP

An experimental investigation of the practicability and potentialities of the dynamic-trap approach to the capture of the weaker signal has begun. A demodulated stronger signal, simulated by an audio oscillator, will be used in conjunction with a reactance-tube circuit to adjust a resonant trap (inserted in the i-f section of an FM receiver) so that its center frequency will follow the instantaneous-frequency position of the stronger signal and attenuate it.

Of especial interest is the distortion from the FM transients and the capture transitions that occur when the weaker signal is swept across the trap frequency.

G. J. Rubissow

D. AMPLITUDE LIMITERS

A theoretical study of amplitude limiters is in progress, the purpose of which is to provide parameters in terms of which the performance of a limiter can be described conveniently and accurately.

A resistive model for a double-diode crystal limiter was used, and relations between the input current and the fundamental component of the output voltage were found for several values of diode bias. Particular values calculated with the help of these relations are in close agreement with available experimental data (1, 2).

L. C. Bahiana

References

1. R. A. Paananen, IF and detector design for FM, TV and Radio Engr. 23, nos. 2-4 (1953).
2. E. P. Brandeau, A broad band limiter at 200 MC, S. M. Thesis, Department of Electrical Engineering, M.I.T., 1950.

E. FM TRANSIENTS

The experimental study of FM transients and the necessary conditions for FM quasi-stationary response of a single-tuned circuit has been completed. A report is being prepared.

D. D. Weiner

(VIII. FREQUENCY MODULATION)

F. DESIGN AND ADJUSTMENT OF BANDPASS AMPLIFIERS

1. Loci of Poles of Single- and Double-Tuned Circuits

The properties and s-plane plots of some simple circuits have been studied in connection with designing bandpass amplifiers. It has proved useful to know the locus of the poles of the single-tuned parallel RLC circuit shown in Fig. VIII-3 when any of the three parameters, C, R, L, is varied. If R is varied, α and ω_d vary, and ω_o is unchanged; thus the poles move along the semicircle of radius ω_o centered at the origin. If L is varied, ω_o and ω_d vary, and α is unchanged; thus the poles move along a line of constant α parallel to the j-axis. If C is varied, the locus can be found by rewriting the general equation

$$\alpha^2 + \omega_d^2 = \omega_o^2$$

in the form

$$\alpha^2 + \omega_d^2 = \frac{1}{LC} = 2\alpha \frac{R}{L}$$

whence

$$\left(\alpha - \frac{R}{L}\right)^2 + \omega_d^2 = \left(\frac{R}{L}\right)^2$$

which is the equation of a circle of radius R/L tangent to the j-axis at the origin. In all three cases, when $\alpha > \omega_o$, the circuit becomes overdamped and the poles move in opposite directions along the negative real axis (symmetrically with respect to the point $\sigma = -1/2RC$ when L is the changing parameter). The three loci are shown in Fig. VIII-4.

From these loci, the loci of the poles of the five possible configurations of the double-tuned circuit can be found. As an example, consider the double-tuned circuit with adjustable mutual-inductive coupling shown in Fig. VIII-5. Since the poles of the transfer impedance are given by the open-circuit natural frequencies of the network, they may be found by observing the (complex) frequencies at which the impedance

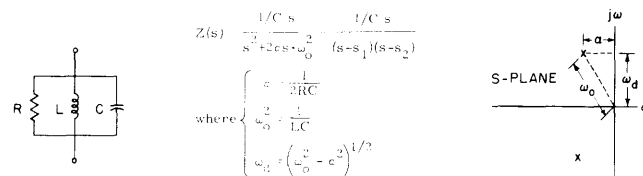

Fig. VIII-3. Single-tuned circuit.

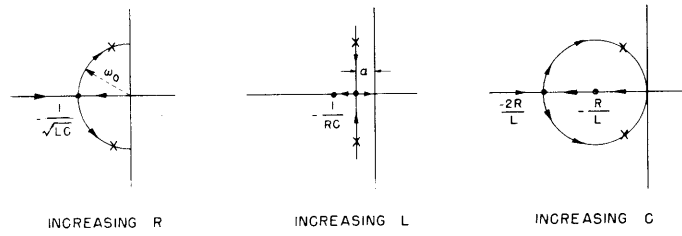

Fig. VIII-4. Loci for poles of single-tuned circuit.

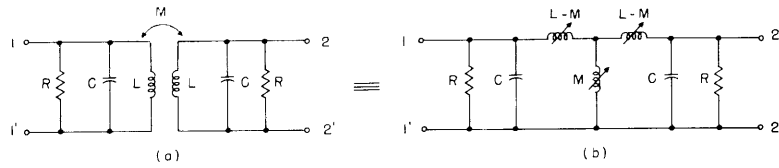

Fig. VIII-5. Double-tuned circuit with mutual-inductive coupling.

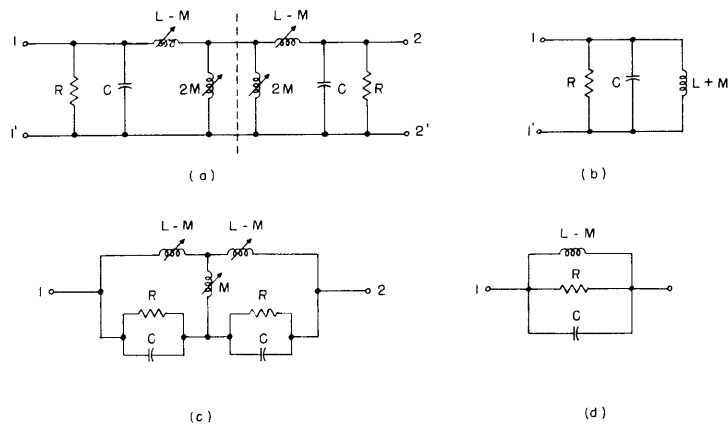

Fig. VIII-6. Analysis of double-tuned circuit.

(VIII. FREQUENCY MODULATION)

appears infinite when viewed across a soldering-iron entry. The poles placed in evidence at terminal pair 1-1' can be found by redrawing the circuit of Fig. VIII-5b as in Fig. VIII-6a. Because of the symmetry of the circuit, the poles of both halves are the same and are the poles of the circuit of Fig. VIII-6b,

$$s_{1,3} = -a \pm j \omega_1$$

where $a = 1/2RC$, $\omega_1 = (\omega_{o1}^2 - a^2)^{1/2}$, and $\omega_{o1}^2 = 1/(L+M)C$. Looking into the network from terminal pair 1-2, we see the circuit of Fig. VIII-6c which has the form of a balanced bridge. Thus the inductor M can be replaced by a short circuit, and the poles are those of either half, as shown in Fig. VIII-6d,

$$s_{2,4} = -a \pm j \omega_2$$

where $a = 1/2RC$, $\omega_2 = (\omega_{o2}^2 - a^2)^{1/2}$, and $\omega_{o2}^2 = 1/(L-M)C$. For $M = 0$, the poles coincide, as is evident from

$$s_{1,3} = s_{2,4} = -a \pm j \omega_c$$

where $a = 1/2RC$, $\omega_c = (\omega_{oc}^2 - a^2)^{1/2}$, and $\omega_{oc}^2 = 1/LC$. If M is increased from zero, the inductance in Fig. VIII-6d is decreased so that the poles separate and move in opposite directions from ω_c , along a line parallel to the j -axis. The separation is approximately symmetrical when it is small.

The other four configurations of the double-tuned circuit can be analyzed in a similar manner. The loci are all summarized in Fig. VIII-7.

2. Loci of Peaks and Half-Power Points for Symmetrical Pair of Poles

When adjusting a bandpass amplifier, it is desirable to distinguish the pole locations from steady-state frequency response measurements. The properties of a pair of poles that are at the same distance from the j -axis were investigated for this purpose. In Fig. VIII-8 the frequency at which a peak occurs will be the j -axis point for which the product of the vectors r_1 and r_2 is minimum. Since the area of the shaded triangle is given by

$$A = \frac{1}{2} 2ab = ab = \frac{1}{2} r_1 r_2 \sin \theta$$

we have

$$r_1 r_2 \stackrel{\Delta}{=} R = \frac{2ab}{\sin \theta}$$

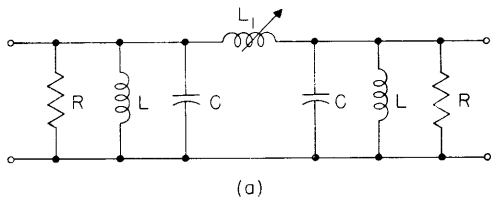

$$Z_{12}(s) = \frac{\frac{1}{C^2 L_1} s}{(s^2 + 2as + \omega_{01}^2)(s^2 + 2cs + \omega_{02}^2)}$$

$$a = \frac{1}{2RC}, \quad \omega_{01}^2 = \frac{1}{LC}$$

$$\omega_{02}^2 = \frac{1}{L_{eq}C}$$

where

$$L_{eq} = L // \frac{L_1}{2}$$

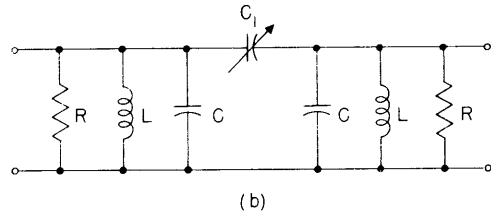
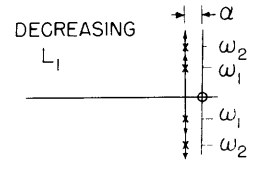

$$Z_{12}(s) = \frac{\frac{C_1}{C(C+2C_1)} s^3}{(s^2 + 2a_1s + \omega_{01}^2)(s^2 + 2a_2s + \omega_{02}^2)}$$

$$a_1 = \frac{1}{2RC}, \quad \omega_{01}^2 = \frac{1}{LC}$$

$$a_2 = \frac{1}{2R(C+2C_1)}, \quad \omega_{02}^2 = \frac{1}{L(C+2C_1)}$$

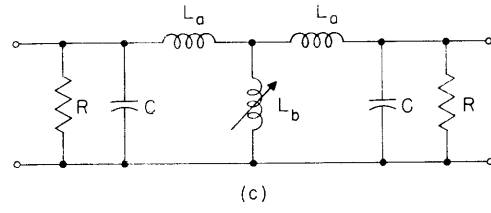
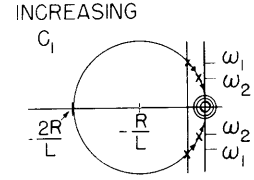

$$Z_{12}(s) = \frac{(L_a \omega_{01}^2 \omega_{02}^2) s}{(s^2 + 2as + \omega_{01}^2)(s^2 + 2cs + \omega_{02}^2)}$$

$$a = \frac{1}{2RC}, \quad \omega_{01}^2 = \frac{1}{L_a C}$$

$$\omega_{02}^2 = \frac{1}{(L_a + 2L_b) C}$$

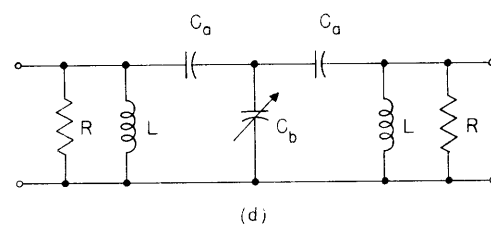
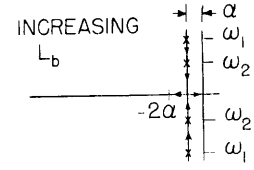

$$Z_{12}(s) = \frac{\frac{C_a \omega_{01}^2 \omega_{02}^2}{C_a + 2C_b} s^3}{(s^2 + 2a_1s + \omega_{01}^2)(s^2 + 2cs + \omega_{02}^2)}$$

$$a_1 = \frac{1}{2RC_a}, \quad \omega_{01}^2 = \frac{1}{LC_a}$$

$$a_2 = \frac{1}{2RC_s}, \quad \omega_{02}^2 = \frac{1}{LC_s}$$

where

$$C_s = \frac{C_a(2C_b)}{C_a + 2C_b}$$

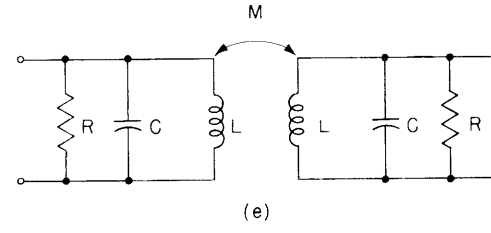
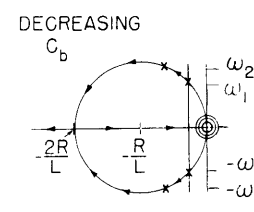

$$Z_{12}(s) = \frac{M \omega_{01}^2 \omega_{02}^2 s}{(s^2 + 2cs + \omega_{01}^2)(s^2 + 2cs + \omega_{02}^2)}$$

$$a = \frac{1}{2RC}, \quad \omega_{01}^2 = \frac{1}{(L+M)C}$$

$$\omega_{02}^2 = \frac{1}{(L-M)C}, \quad \omega_c^2 = \frac{1}{LC}$$

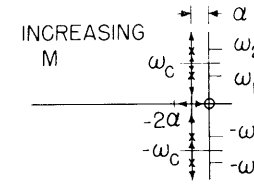

Fig. VIII-7. Loci for poles of double-tuned circuits. In all cases:

$$\omega_1 = (\omega_{01}^2 - a_1^2)^{1/2}, \quad \omega_2 = (\omega_{02}^2 - a_2^2)^{1/2}.$$

(VIII. FREQUENCY MODULATION)

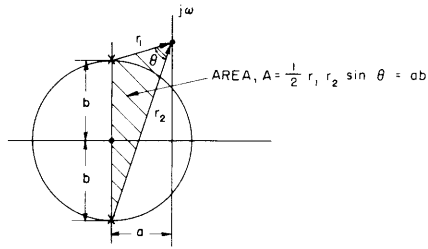

Fig. VIII-8. s-plane construction.

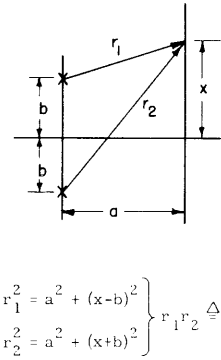

Fig. VIII-9. s-plane frequency factors.

which is minimum when $\sin \theta$ is maximum (1). There are two possible cases. When $a \leq b$ (the overcoupled case), the maximum of $\sin \theta$ occurs for $\theta = 90^\circ$; hence the vectors r_1 and r_2 must form a right triangle, and peaks occur at the intersection of the j -axis with the circle that is drawn with the line segment joining the poles as diameter. When $a \geq b$ (the undercoupled case), θ can never become as large as 90° ; hence there is only one peak, halfway between the poles. The intermediate case, in which $a = b$ and the circle is tangent to the j -axis, is the critically coupled, or maximally flat, case. Note that only in the overcoupled case is there a one-to-one correspondence between the loci of the poles and the peak frequencies.

The half-power points relative to the amplitude at the center frequency can be found by referring to Fig. VIII-9. At the center frequency, the product of the vectors is

$$R_c^2 = (a^2 + b^2)^2$$

and, at a frequency x from the center, it is

$$R^2 = [a^2 + (x-b)^2] [a^2 + (x+b)^2] = x^4 + 2x^2(a^2 - b^2) + (a^2 + b^2)^2$$

These two products must be related by $R = \sqrt{2} R_c$. Solving for x , we obtain

$$x^2 = (b^2 - a^2) + [2(a^4 + b^4)]^{1/2}$$

$$\left(\frac{x}{b}\right)^2 = \left[1 - \left(\frac{a}{b}\right)^2\right] + \sqrt{2\left[1 + \left(\frac{a}{b}\right)^4\right]}$$

Normalize, by letting $b = 1$, to obtain

$$x = \left(1 - a^2 + \sqrt{2(1 + a^4)}\right)^{1/2}$$

This relation gives the half-power frequency with respect to the center frequency in

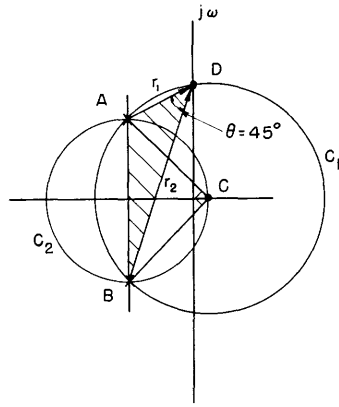

Fig. VIII-10. s-plane construction.

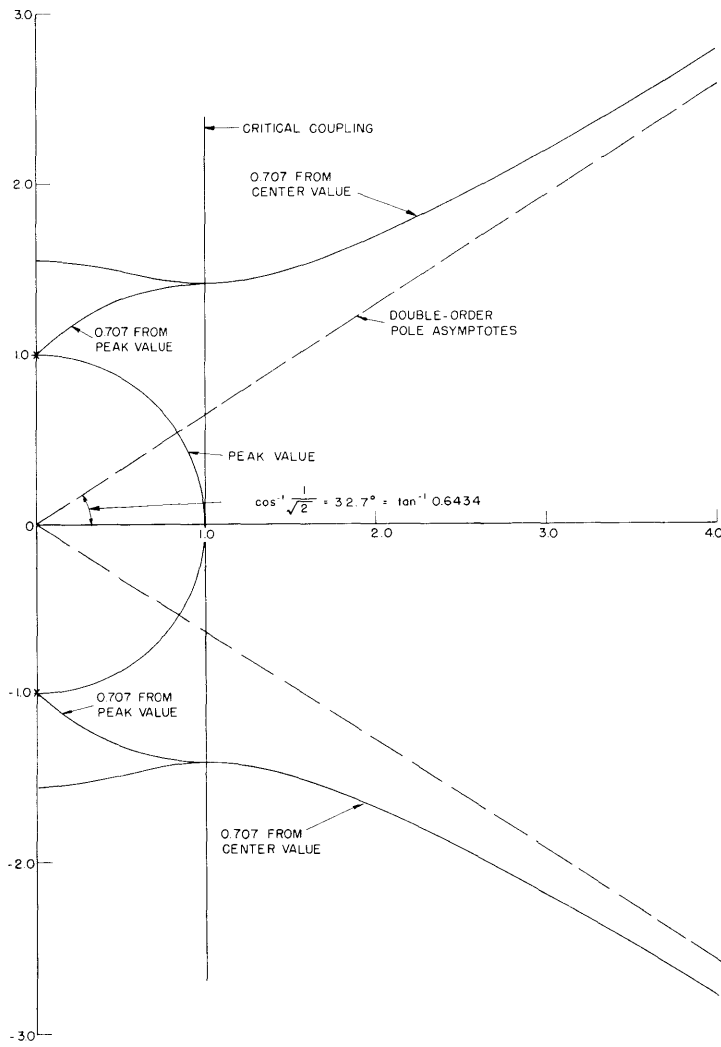

Fig. VIII-11. Loci of peaks and half-power points for symmetrical pair of poles.

(VIII. FREQUENCY MODULATION)

both the undercoupled and overcoupled cases.

In the overcoupled case it is of interest to find the frequency that corresponds to a half-power point relative to the peaks. At the peak frequencies, $\sin \theta = 1$, and $r_1 r_2 = R_p = 2ab$. At the half-power points relative to the peaks, $R = \sqrt{2} R_p$, so that the half-power frequencies occur when

$$\frac{2ab}{\sin \theta} = 2 \sqrt{2} ab \quad \text{or} \quad \theta = 45^\circ$$

Referring to Fig. VIII-10, we see that the right angle ACB intercepts a 90° arc on the circle C_1 . Since the sides of an angle whose vertex lies on the arc of a circle intercept $\theta^\circ/2$ of arc, the angle θ between the vectors AD and BD must be the required 45° . Thus the half-power points with respect to the peaks occur at the intersections of the large circle with the j -axis.

The normalized loci of peaks and half-power points for the symmetrical pair of poles is presented in Fig. VIII-11. These plots are useful in the design of bandpass amplifiers. We feel that the method of adjusting the positions of poles by the use of these loci has the advantage that the frequency response of the system can be directly observed and adjusted. It also offers a meaningful quantitative measure of the degree to which correct adjustment of the network has been achieved.

R. J. McLaughlin

References

1. E. J. Angelo, *Electronic Circuits Course Notes*, Polytechnic Institute of Brooklyn, 1957.