

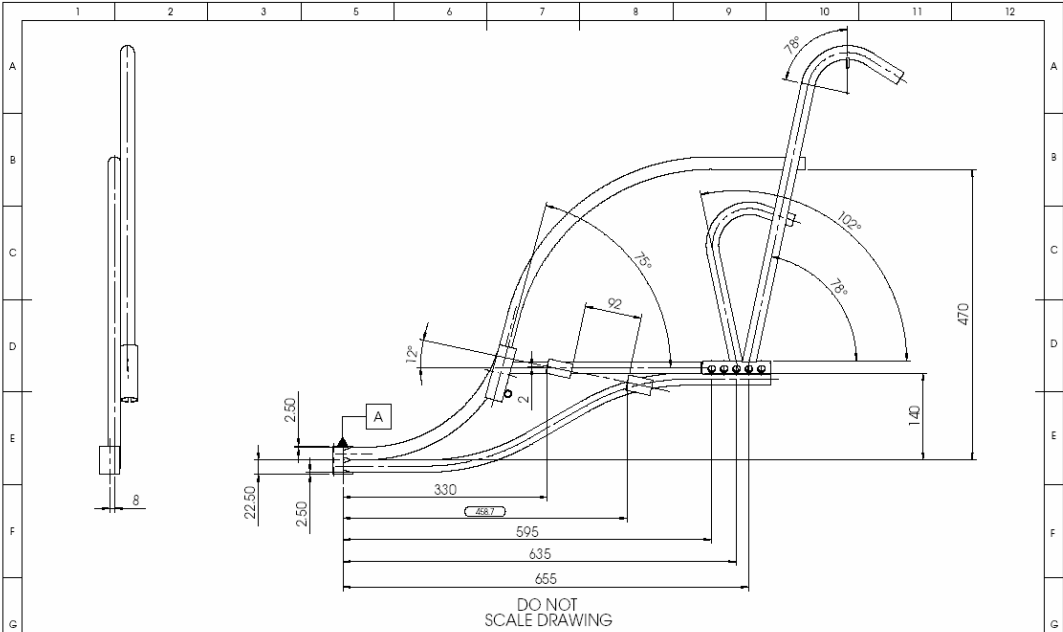

THE DESIGN PROCESS

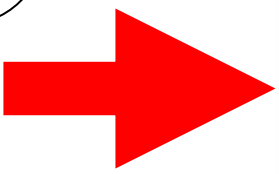

Drawn By: Whirlwind Wheelchair International	Approval Date: Not Approved	Material: See individual part sheets	Stock Dimensions: See individual part sheets	Finish: Debur, round all edges, clean brazed areas	Approx. Scale: 1:6	Sheet Number: 13 of 14	Sheet Format: A4	
Project Title: Ultra Liviano Wheelchair	Drawn By: C Howard	Description: The Side Frame Assembly dictates the chair's form and critically affects the wheelchair's overall quality.	UNLESS OTHERWISE SPECIFIED: DIMENSIONS ARE IN MILLIMETERS					
Part Title: Side Frame - General Assembly	Part Number: SFA	Additional Information:	TOLERANCES: LINEAR: ±0.5 ANGULAR: ±5°					
Part Created Date: 12/12/2003	Quantity: 2	Revision and Revision Date: 3 on 2/1/2004						© Whirlwind Wheelchair International



Ralf Hotchkiss
Whirlwind

Courtesy of Whirlwind Wheelchair International. Used with permission.



- **Creativity and Analytical skills**
 - Great engineers know when to use both
 - Know when to use enough
 - **Both can be improved with practice**
- **Have a passion for what you do**



POWER OF THE DESIGN PROCESS

- **Break down a complex system into manageable chunks**
- **Applicable to any system, in any area of engineering (or any other project)**

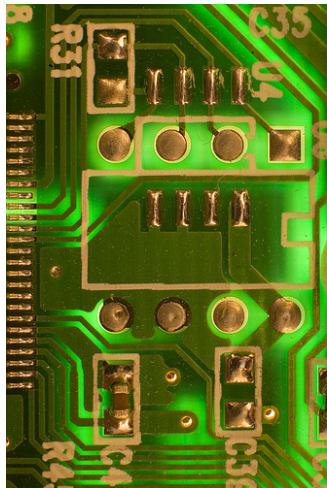

Courtesy of MarkyBon.
<http://www.flickr.com/photos/markybon/372533194/>



Courtesy of salihan.
<http://www.flickr.com/photos/salihan/635234235/>



Courtesy of NASA.



- **Make engineering choices for a reason**
 - “Determine” what best engineering decision
 - Example Factors: cost, size, time, color, etc.
- **Manage your projects effectively**
 - Time, money, performance
- **Always have a backup plan**
 - First rule of engineering – it rarely works perfectly the first time



MONITOR COST VS. PERFORMANCE

- **Use your energy effectively to achieve worthwhile performance**

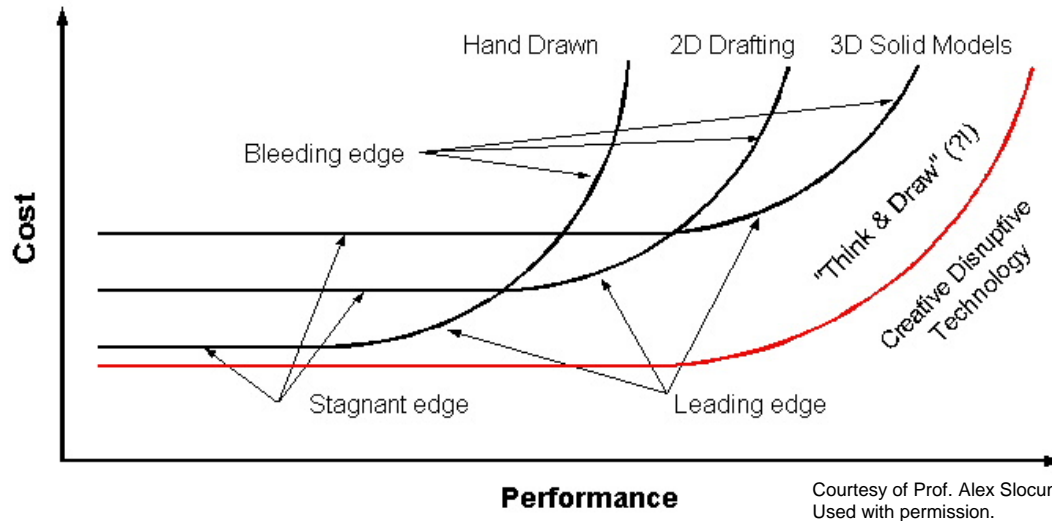

- Don't reinvent the wheel if you are only go 1% faster
- Cost is not just money, it is also time spent



Start vague and gradually become specific

1. **Strategy:** A **PLAN** of how to do something (with no specific embodiment)
2. **Concept:** Idea for **DEVICE** to fulfill need (rough physical picture)
3. **Module:** Important aspect of design (ex-linkage, motor, color scheme)
4. **Component:** Specific part design



THE DETERMINISTIC DESIGN PROCESS

Deterministic Design: *Funnels: Strategies* *Concepts* *Modules* *Components*

- Deterministic Design leaves LOTS of room for the wild free creative spirit, and LOTS of room for experimentation and play
- Deterministic Design is a catalyst to funnel creativity into a *successful* design

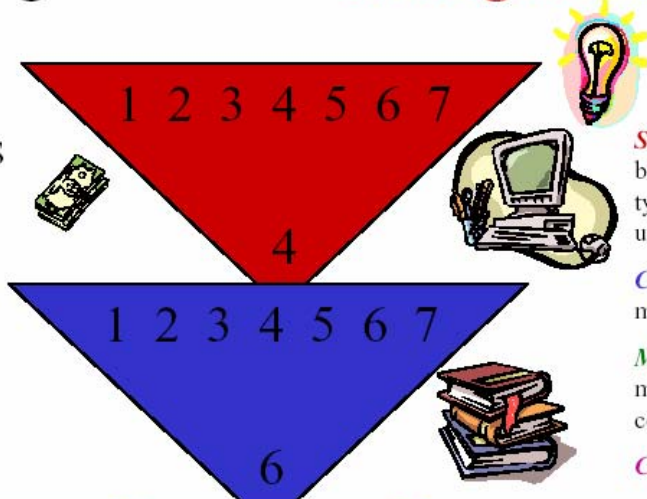

Strategy: Plan or tactics to score but there may be many different types of machines that could be used

Concept: An idea for a specific machine that can execute a strategy

Module: A sub assembly of a machine that by itself executes a certain function

Component: An individual part

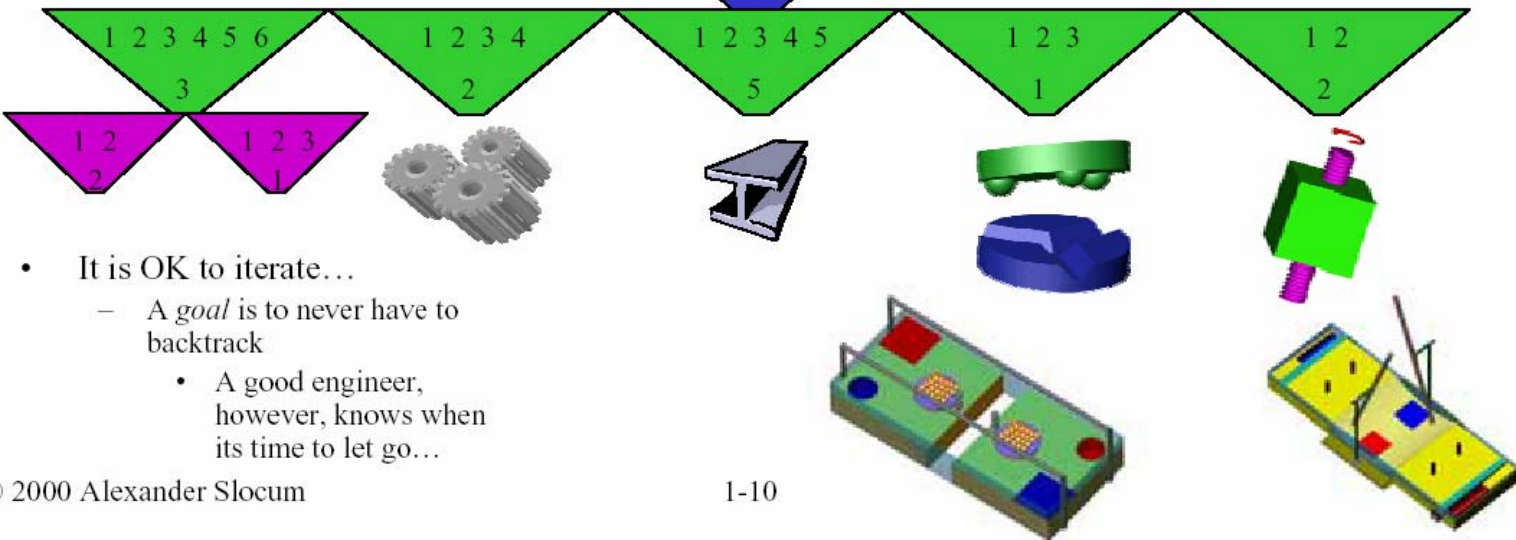

- It is OK to iterate...
 - A *goal* is to never have to backtrack
 - A good engineer, however, knows when its time to let go...

BE DETERMINISTIC AT EVERY STAGE OF THE PROCESS



Source: 2.007 lecture notes
Courtesy of Prof. Alex Slocum.
Used with permission.

FRDPARRC: Your new best friend

- **FR** = **Functional Requirements** (**WHAT** the design has to do)
- **DP** = **Design Parameters** (**HOW** the design is going to meet the FR)
- **A** = **Analysis** (justify your decisions; can be qualitative or quantitative)
- **R** = **Research** (don't reinvent the wheel)
- **R** = **Risk** (what is going to bit you in the ass if it doesn't work?)
- **C** = **Countermeasure** (If S*#T hits fan, how can you maintain progress?)

Identify your Design Freedoms: What elements of the local environment or available resources can you capitalize on?

Identify your Design Constraints: What material/processes/resources/knowledge/etc can you absolutely not use?

IT'S TIME TO DESIGN!

Example: FR – Allow a person who is disabled to have mobility

Image removed due to copyright restrictions.



**Whirlwind (USA)
designed, locally made**



**Wheelchair
Foundation
(USA)
designed,
made in
China**



**Locally designed,
locally made**

**Motivation (UK)
designed, locally made**



Image removed due to copyright restrictions. Photo of Wheelchair Foundation chair.



CAPITALIZING ON DESIGN FREEDOMS

Treadle pump



Photo courtesy of Alfinio Flores. Used with permission.

Courtesy of New Dawn Engineering. Used with permission.



CAPITALIZING ON DESIGN FREEDOMS

Bicycle component usage





CHOOSING PROJECT TEAMS

[See the proposed projects list]



HOMEWORK FOR NEXT WEEK

- **Read “Nothing about us without us”**
 - Focus on designing for specific problems and utilizing local materials
- **Read “2.007 Design Process notes”**
- **Watch remainder of workshop movies**
- **Coordinate with lab instructor and choose lab time**
 - I will email each team who their lab instructor is and make email lists
- **Email mentors and community partners**
- **Start working on defining functional requirements for your project**
 - Ask your community partners and mentors for input