

MIT Open Access Articles

*Task-space setpoint control of robots
with dual task-space information*

The MIT Faculty has made this article openly available. **Please share** how this access benefits you. Your story matters.

Citation: Cheah, C.C., and J. Slotine. "Task-space setpoint control of robots with dual task-space information." *Robotics and Automation*, 2009. ICRA '09. IEEE International Conference on. 2009. 3706-3711. © 2009 IEEE

As Published: <http://dx.doi.org/10.1109/ROBOT.2009.5152417>

Publisher: Institute of Electrical and Electronics Engineers

Persistent URL: <http://hdl.handle.net/1721.1/53750>

Version: Final published version: final published article, as it appeared in a journal, conference proceedings, or other formally published context

Terms of Use: Article is made available in accordance with the publisher's policy and may be subject to US copyright law. Please refer to the publisher's site for terms of use.



Task-space Setpoint Control of Robots with Dual Task-space Information

C. C. Cheah

*School of Electrical and Electronic Engineering
Nanyang Technological University
Block S1, Nanyang Avenue, S(639798)
Republic of Singapore*

J. J. E. Slotine

*Nonlinear Systems Laboratory
Massachusetts Institute of Technology
77 Massachusetts Ave
Cambridge, MA 02139 USA*

Abstract—In conventional task-space control problem of robots, a single task-space information is used for the entire task. When the task-space control problem is formulated in image space, this implies that visual feedback is used throughout the movement. While visual feedback is important to improve the endpoint accuracy in presence of uncertainty, the initial movement is primarily ballistic and hence visual feedback is not necessary. The relatively large delay in visual information would also make the visual feedback ineffective for fast initial movements. Due to limited field of view of the camera, it is also difficult to ensure that visual feedback can be used for the entire task. Therefore, the task may fail if any of the features is out of view. In this paper, we present a new task-space control strategy that allows the use of dual task-space information in a single controller. We shall show that the proposed task-space controller can transit smoothly from Cartesian-space feedback at the initial stage to vision-space feedback at the end stage when the target is near.

I. INTRODUCTION

Typical applications of robots are specified in task space such as Cartesian space or visual space. In task space control method [1], [2], [3], [4], [5], a task oriented information is used directly in the feedback control law to eliminate the need of solving inverse kinematics. However, most task-space controllers [1], [2], [3], [4], [5] have assumed that the exact kinematics and Jacobian matrix of the manipulator from joint space to task space are known. To overcome the problem of uncertain kinematics, several approximate Jacobian setpoint controllers have been proposed [6], [7], [8]. The controllers do not require the exact knowledge of robot kinematics. Recently, a region reaching control scheme is proposed in [9]. In this control concept, the desired objective can be specified as a region instead of a point. Since the desired region can be specified arbitrarily small, the region control concept is also a generalization of setpoint control problem.

If cameras are used to monitor the position of the end-effector, the task coordinates are defined as image coordinates. It is well known that the task-space controllers [1], [2], [3], [4], [5] can be directly extended to vision-space controllers if the exact image Jacobian matrix of the mapping from Cartesian space to image space is known. However, in presence of modeling and calibration errors, the image Jacobian matrix is uncertain. Though much progress has

also been obtained in the literature of visual servoing [10], [11], [12], [13], there are only a few theoretical results been obtained for the stability analysis in presence of the uncertain camera parameters [11], [12], [13]. In these results, the effects of nonlinearity and uncertainties of the robot kinematics and dynamics are not taken into consideration. The approximate Jacobian controller [6], [7], [8] can be used in visual servoing with uncertain camera parameters, taking the nonlinearity and uncertainties of the robot kinematics and dynamics into consideration. To deal with depth uncertainty, several image based controllers have been proposed in [15], [14].

In these task-space controllers, a single task-space information in either Cartesian space [1], [2], [3], [4], [5][9] or vision space [6], [7], [8][15], [14] is used for the entire task. While visual feedback is important to improve the endpoint accuracy in presence of uncertainty, the initial movement is mainly ballistic and hence visual feedback is not necessary. The relatively large sampling time from vision makes implementation of the image based controllers a difficult problem. In addition, it is difficult to choose cameras that cover the entire workspace of a robot since an increase in field of view results in a reduction in visual acuity and vice versa. In this paper, we present a new task-space control strategy that allows the use of dual task-space information for a single controller. The proposed task-space controller only requires vision feedback when the end effector is near the desired position. The proposed controller consists of a Cartesian-space region reaching controller that is activated at the initial stages and a vision based controller that is only activated when the end effector is in the vicinity of the desired position. We shall show that the proposed task-space controller can transit smoothly from Cartesian-space feedback to vision-space feedback. The controller is inspired from human visual guided reaching tasks where we do not track our hand using vision for the entire task but only when it is near the target. The main contributions of this paper are the development of a new task-space control strategy with dual task-space information and the establishment of a theoretical analysis on the stability of the system. The effects of the robot dynamics are taken into consideration in the stability analysis. The proposed controller is implemented

on an industrial robot and experiment results using shadow feedback are presented.

II. ROBOT KINEMATICS AND DYNAMICS

We consider a robot system with camera(s) fixed in the work space. Let $r \in \mathbb{R}^p$ denote a position of the end effector in Cartesian space as [3], [16],

$$r = h(q) \quad (1)$$

where $h(\cdot) \in \mathbb{R}^n \rightarrow \mathbb{R}^p$ is generally a non-linear transformation describing the relation between joint space and task space, $q = [q_1, \dots, q_n]^T \in \mathbb{R}^n$ is a vector of joint angles of the manipulator. The velocity of the end-effector \dot{r} is related to joint-space velocity \dot{q} as:

$$\dot{r} = J_m(q)\dot{q} \quad (2)$$

where $J_m(q) \in \mathbb{R}^{p \times n}$ is the Jacobian matrix from joint space to task space.

For a visually-servoed system, cameras are used to observe the position of the end-effector in image space. The mapping from Cartesian space to image space requires a camera-lens model in order to represent the projection of task objects onto the CCD image plane. We use the standard pinhole camera model, which has been proven adequate for most visual servoing tasks [10]. Let $x = [x_1, x_2, \dots, x_m]^T \in \mathbb{R}^m$ denote a vector of image feature parameters and \dot{x} the corresponding vector of image feature parameter rates of change. The relationship between Cartesian space and image space is represented by [10], [14],

$$\dot{x} = J_I(r)\dot{r}, \quad (3)$$

where $J_I(r) = Z^{-1}(q)L(r) \in \mathbb{R}^{m \times p}$ is the image Jacobian matrix, $Z(q)$ is a diagonal matrix that contain the depth information of the feature points with respect to the camera image frame, $L(r)$ is the remaining Jacobian matrix. The image Jacobian was first introduced by Weiss et al. [17], who referred to it as the feature sensitivity matrix. It is also referred to as the interaction matrix [18].

From equations (2) and (3), we have,

$$\dot{x} = J_I(r)J_m(q)\dot{q} = J(q)\dot{q}, \quad (4)$$

where $J(q) \in \mathbb{R}^{m \times n}$ is the Jacobian matrix mapping from joint space to image space.

The equations of motion of the robot in is given in joint space as [3], [16]:

$$M(q)\ddot{q} + \left(\frac{1}{2}\dot{M}(q) + S(q, \dot{q})\right)\dot{q} + g(q) = \tau, \quad (5)$$

where $M(q) \in \mathbb{R}^{n \times n}$ is an inertia matrix, $g(q) \in \mathbb{R}^n$ denotes a gravitational force vector, $\tau \in \mathbb{R}^n$ denotes the control inputs, and,

$$S(q, \dot{q})\dot{q} = \frac{1}{2}\dot{M}(q)\dot{q} - \frac{1}{2}\left\{\frac{\partial}{\partial q}\dot{q}^T M(q)\dot{q}\right\}^T.$$

Two important properties of the robot dynamics described by equation (5) are given as follows [3], [16]:

Property 1: The inertia matrix $M(q)$ is symmetric and positive definite for all $q \in \mathbb{R}^n$.

Property 2: The matrix $S(q, \dot{q})$ is skew-symmetric such that:

$$y^T S(q, \dot{q})y = 0, \quad (6)$$

for any $y \in \mathbb{R}^n$.

III. TASK-SPACE SETPOINT CONTROL WITH DUAL TASK-SPACE INFORMATION

In this section, we present a novel robot controller that do not use vision for the entire task but only when the end effector is near a desired position. The main idea is to use a Cartesian-space region reaching controller [9] at the initial stages (i.e. without using vision) and then introduce a vision based controller that is only activated when the end effector is in the vicinity of the desired position.

Let $x_d = [x_{1d}, x_{2d}, \dots, x_{md}]^T \in \mathbb{R}^m$ be a desired position of the end effector in image space. We define a region in the vicinity of the desired position as follows:

$$f_x(\Delta x) = (x_1 - x_{1d})^2 + (x_2 - x_{2d})^2 + \dots + (x_m - x_{md})^2 - r_x \leq 0, \quad (7)$$

where $\Delta x = x - x_d$, $f_x(\Delta x) \in \mathbb{R}$ is a scalar functions and r_x is a positive constant.

Using the above scalar function, a potential energy function is specified in image space as:

$$P_x(x) = \frac{k_{px}}{2}(r_x^2 - [\min(0, f_x(\Delta x))]^2). \quad (8)$$

where k_{px} is a positive constant. That is,

$$P_x(x) = \begin{cases} \frac{k_{px}}{2}r_x^2, & f_x(\Delta x) \geq 0, \\ \frac{k_{px}}{2}(r_x^2 - f_x^2(\Delta x)), & f_x(\Delta x) < 0, \end{cases} \quad (9)$$

The above energy function is lower bounded by zero. When $f_x(\Delta x) < 0$,

$$\begin{aligned} P_x(x) &= \frac{k_{px}}{2}(r_x^2 - f_x^2(\Delta x)), \\ &= \frac{k_{px}}{2}(r_x^2 - \{(x_1 - x_{1d})^2 + (x_2 - x_{2d})^2 + \dots \\ &\quad + (x_m - x_{md})^2 - r_x\}^2) \end{aligned} \quad (10)$$

Note that $P_x(x) = 0$ if $\Delta x = 0$ and $P_x(x) \rightarrow \frac{k_{px}}{2}r_x^2$ as $(x_1 - x_{1d})^2 + (x_2 - x_{2d})^2 + \dots + (x_m - x_{md})^2 \rightarrow r_x$ (or $f_x(\Delta x) \rightarrow 0$). An illustration of the energy function is shown in figure 1.

Partial differentiating the potential energy function (9) with respect to x , we have,

$$\left(\frac{\partial P_x(x)}{\partial x}\right)^T = \begin{cases} 0, & f(\Delta x) \geq 0, \\ -k_{px}f_x(\Delta x)\left(\frac{\partial f_x(\Delta x)}{\partial x}\right)^T, & f_x(\Delta x) < 0, \end{cases} \quad (11)$$

which can be written as,

$$\left(\frac{\partial P_x(x)}{\partial x}\right)^T = -k_{px}\min(0, f_x(\Delta x))\left(\frac{\partial f_x(\Delta x)}{\partial x}\right)^T. \quad (12)$$

where $\left(\frac{\partial f_x(\Delta x)}{\partial x}\right)^T = 2\Delta x$. Note that $-k_{px}\min(0, f_x(\Delta x))$ is positive when $f_x(\Delta x) < 0$.

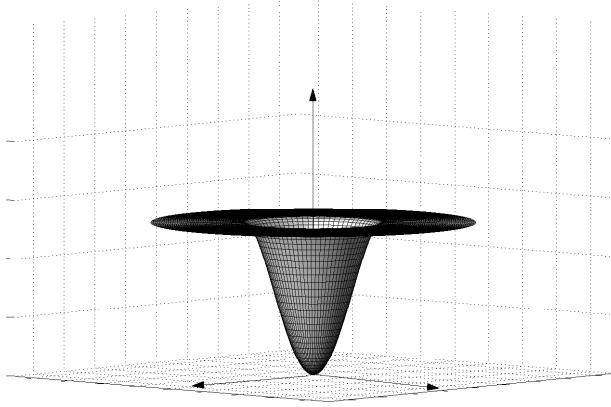

Fig. 1. Illustration of the potential energy function (image space)

For clarity of presentation, we first introduce the vision based controller that is activated when the end effector is within the visual region (7), and then combine it with the Cartesian-space region controller that drive the end effector to the region. Based on equation (12), a vision-space controller is proposed as:

$$\tau = -K_v \dot{q} + J^T(q) k_{px} \min(0, f_x(\Delta x)) \left(\frac{\partial f_x(\Delta x)}{\partial x} \right)^T + g(q), \quad (13)$$

where $K_v \in R^{n \times n}$ is a positive definite velocity feedback gain matrix, $J^T(q)$ is the transpose of the Jacobian matrix. As seen from (12) and figure 1, there is no change in potential energy with respect to position when x is on or outside the region. Hence, the position control term $-k_{px} \min(0, f_x(\Delta x)) \left(\frac{\partial f_x(\Delta x)}{\partial x} \right)^T$ is zero when x is outside the region (i.e. $f_x(\Delta x) > 0$). If the end effector enters the region, it is then attracted to a minimum point where $\Delta x = 0$ and $P_x(x) = 0$. It is clear that when $f_x(\Delta x) < 0$, the control term $-k_{px} \min(0, f_x(\Delta x)) \left(\frac{\partial f_x(\Delta x)}{\partial x} \right)^T = -2k_{px} f_x(\Delta x) \Delta x$ is non zero unless $\left(\frac{\partial f_x(\Delta x)}{\partial x} \right)^T = 2\Delta x = 0$.

Substituting the control law (13) into the robot dynamics (5), the closed-loop equation is obtained as:

$$M(q)\ddot{q} + \left(\frac{1}{2}\dot{M}(q) + S(q, \dot{q})\right)\dot{q} + K_v \dot{q} - J^T(q) [k_{px} \min(0, f_x(\Delta x)) \left(\frac{\partial f_x(\Delta x)}{\partial x} \right)^T] = 0. \quad (14)$$

A Lyapunov-like function is proposed as:

$$V = \frac{1}{2} \dot{q}^T M(q) \dot{q} + P_x(x), \quad (15)$$

where $P_x(x)$ is defined in equation (8). Since $f_x(x)$ is continuous in x , V is also a continuous scalar function with continuous first partial derivatives. Differentiating equation (15) with respect to time, yields:

$$\dot{V} = \dot{q}^T M(q) \ddot{q} + \frac{1}{2} \dot{q}^T \dot{M}(q) \dot{q} + \dot{x}^T \left(\frac{\partial P_x(x)}{\partial x} \right)^T. \quad (16)$$

Substituting equations (11) and (14) into equation (16), we

have,

$$\begin{aligned} \dot{V} = & -\dot{q}^T S(q, \dot{q}) \dot{q} - \dot{q}^T K_v \dot{q} \\ & + k_{px} \min(0, f_x(\Delta x)) \dot{q}^T J^T(q) \left(\frac{\partial f_x(\Delta x)}{\partial x} \right)^T \\ & - k_{px} \min(0, f_x(\Delta x)) \dot{x}^T \left(\frac{\partial f_x(\Delta x)}{\partial x} \right)^T. \end{aligned} \quad (17)$$

Since $\dot{x} = J(q)\dot{q}$, simplifying equation (17) and applying Property 2, \dot{V} reduces to:

$$\dot{V} = -\dot{q}^T K_v \dot{q} \leq 0. \quad (18)$$

Since $\dot{V} = 0$ implies $\dot{q} = 0$ as $t \rightarrow \infty$, the following maximum invariant set [19] is satisfied

$$2J(q)^T k_{px} \min(0, f_x(\Delta x)) \Delta x = 0.$$

Hence $\min(0, f_x(\Delta x)) \Delta x = 0$ and $\dot{q} = 0$ as $t \rightarrow \infty$ if $J(q)$ is of full rank. Note that only if $x(0) = h(q(0))$ is inside the region $f_x(\Delta x) < 0$ such that $P_x(x(0)) < \frac{k_{px}}{2} r_x^2$, then it follows from (18) that $\Delta x = 0$.

The above analysis shows that if x is within the region $f_x(\Delta x) < 0$ in vision space, then it converges to the desired position x_d as $t \rightarrow \infty$. However it is not activated when x is outside the region. In the following development, we introduce a position control term in Cartesian space to attract the end effector toward $f_x(\Delta x) < 0$. The control term is defined in Cartesian space to eliminate the need of vision at the initial stage where the end effector is far away from x_d . This control term has a reverse role in the sense that it will be inactive when the end effector is near the desired position.

We define a desired region in Cartesian space as follows:

$$f_r(r) \leq 0, \quad (19)$$

where $f_r(r) \in R$ is a scalar functions with continuous first partial derivatives. For example, a desired region can be specified as a sphere as:

$$f_r(r) = (r_1 - r_{1c})^2 + (r_2 - r_{2c})^2 + (r_3 - r_{3c})^2 - a^2 \leq 0, \quad (20)$$

where a is the radius of the sphere, $(r_1, r_2, r_3)^T$ is the position of end effector, $(r_{1c}, r_{2c}, r_{3c})^T$ is the center of the sphere.

A potential energy function is specified in Cartesian space as:

$$P_r(r) = \frac{k_{pr}}{2} [\max(0, f_r(r))]^2. \quad (21)$$

where k_{pr} is a positive constant. That is,

$$P_r(r) = \begin{cases} \frac{k_{pr}}{2} f_r^2(r), & f_r(r) > 0, \\ 0, & f_r(r) \leq 0, \end{cases} \quad (22)$$

Note that the above energy function is lower bounded by zero. An illustration of the energy function is shown in figure 2.

Partial differentiating the potential energy function (22) with respect to r , we have,

$$\left(\frac{\partial P_r(r)}{\partial r} \right)^T = \begin{cases} k_{pr} f_r(r) \left(\frac{\partial f_r(r)}{\partial r} \right)^T, & f_r(r) > 0, \\ 0, & f_r(r) \leq 0, \end{cases} \quad (23)$$

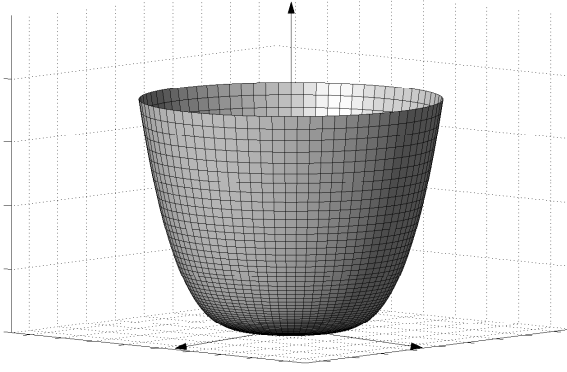

Fig. 2. Illustration of the potential energy function (Cartesian space)

which can be written as,

$$\left(\frac{\partial P_r(r)}{\partial r}\right)^T = k_{pr} \max(0, f_r(r)) \left(\frac{\partial f_r(r)}{\partial r}\right)^T. \quad (24)$$

Note that $f_r(r)$ should be specified so that $\frac{\partial f_r(r)}{\partial r}$ is not equal to zero outside the desired region. For example, if the region specified by (20), then $\frac{\partial f_r(r)}{\partial r} = [2(r_1 - r_{1c}), 2(r_2 - r_{2c}), 2(r_3 - r_{3c})]^T$ which is inside the region. In cases where $\frac{\partial f_r(r)}{\partial r}$ vanishes outside the desired region, then other local minimum exists. However, there always exist a subspace around the desired region such that the desired region is the isolated minimum region.

The above Cartesian-space position control term can be used to attract the end effector toward the vision-space region in the vicinity of x_d . The vision-space control term will then be activated to attract the end effector toward the desired position. The regions should be specified so that both control terms do not vanish at the same time during the transition from Cartesian space control to vision space control. This can be easily guaranteed by specifying the Cartesian space region to be slightly within the visual region. The overall potential energy function is a combination of (8) and (21), and is illustrated in figure 3.

The overall vision based controller with dual task-space information is thus proposed as follows:

$$\begin{aligned} \tau = & -K_v \dot{q} - J_m^T(q) k_{pr} \max(0, f_r(r)) \left(\frac{\partial f_r(r)}{\partial r}\right)^T \\ & + J_m^T(q) J_I^T(x) k_{px} \min(0, f_x(\Delta x)) \left(\frac{\partial f_x(\Delta x)}{\partial x}\right)^T + g(q), \end{aligned} \quad (25)$$

The closed-loop equation of the system is obtained by substituting equation (25) into equation (5) to yield

$$\begin{aligned} M(q) \ddot{q} + C(q, \dot{q}) \dot{q} + K_v \dot{q} \\ + J_m^T(q) k_{pr} \max(0, f_r(r)) \left(\frac{\partial f_r(r)}{\partial r}\right)^T \\ - J_m^T(q) J_I^T(x) k_{px} \min(0, f_x(\Delta x)) \left(\frac{\partial f_x(\Delta x)}{\partial x}\right)^T = 0 \end{aligned} \quad (26)$$

The Lyapunov-like function is proposed as:

$$V = \frac{1}{2} \dot{q}^T M(q) \dot{q} + P_r(r) + P_x(x). \quad (27)$$

Differentiating equation (27) with respect to time and substituting equation (26) into it, we have,

$$\begin{aligned} \dot{V} = & -\dot{q}^T S(q, \dot{q}) \dot{q} - \dot{q}^T K_v \dot{q} \\ & - k_{pr} \max(0, f_r(r)) \dot{q}^T J_m^T(q) \left(\frac{\partial f_r(r)}{\partial r}\right)^T \\ & + k_{pr} \max(0, f_r(r)) \dot{r}^T \left(\frac{\partial f_r(r)}{\partial r}\right)^T \\ & + k_{px} \min(0, f_x(\Delta x)) \dot{q}^T J^T(q) \left(\frac{\partial f_x(\Delta x)}{\partial x}\right)^T \\ & - k_{px} \min(0, f_x(\Delta x)) \dot{x}^T \left(\frac{\partial f_x(\Delta x)}{\partial x}\right)^T \\ = & -\dot{q}^T K_v \dot{q} \leq 0 \end{aligned} \quad (28)$$

We consider a compact set γ in the state space:

$$\Omega = \{(q, \dot{q}) : V \leq \gamma\} \quad (29)$$

where the combination of $P_x(\Delta x)$ and $P_r(r)$ has an isolated minimum at the desired position with a positive γ .

We are now ready to state the following Theorem:

Theorem: Consider the vision based controller described by equations (25), the closed-loop system gives rise to the convergence of x to x_d and \dot{q} to 0 as $t \rightarrow \infty$.

Proof: Since $\dot{V} = 0$ implies $\dot{q} = 0$ as $t \rightarrow \infty$, the following maximum invariant set [19] is satisfied

$$\begin{aligned} J_m^T(q) k_{pr} \max(0, f_r(r)) \left(\frac{\partial f_r(r)}{\partial r}\right)^T \\ - J_m^T(q) J_I^T(x) k_{px} \min(0, f_x(\Delta x)) \left(\frac{\partial f_x(\Delta x)}{\partial x}\right)^T = 0 \end{aligned}$$

Hence $\min(0, f_x(\Delta x)) \left(\frac{\partial f_x(\Delta x)}{\partial x}\right)^T = 0$ and $\dot{q} = 0$ if $J_m(q)$ and $J(q) = J_I(r) J_m(q)$ are of full rank. As stated in (29), we consider a compact set where the combined potential energy function of $P_x(\Delta)$ and $P_r(r)$ has an isolated minimum as the desired position (see figure 3). This means that the gradient of the potential energy, $J_m^T(q) k_{pr} \max(0, f_r(r)) \left(\frac{\partial f_r(r)}{\partial r}\right)^T - J_m^T(q) J_I^T(x) k_{px} \min(0, f_x(\Delta x)) \left(\frac{\partial f_x(\Delta x)}{\partial x}\right)^T$ is zero only if $\Delta x = 0$. This implies that $\Delta x \rightarrow 0$ in Ω as $t \rightarrow \infty$. $\triangle \triangle \triangle$

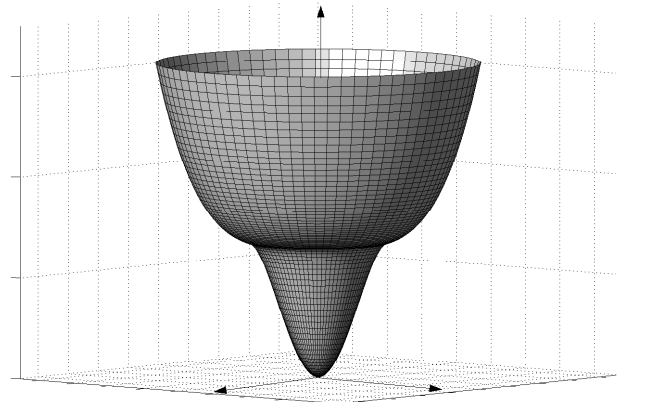

Fig. 3. Illustration of the overall potential energy function

The results can be extended to vision based control without camera calibrations by using an adaptive image Jacobian matrix. In vision control problems, the image velocity is inversely proportional to the depth information and hence the depth information appears nonlinearly in the overall Jacobian matrix thus cannot be adapted together with other unknown kinematic parameters. Some results on image based control with depth uncertainty have been proposed in [15], [14] but vision is used in the entire movement. In the proposed controller in this section, visual feedback is used only when the end effector is near to desired position.

From equation (3), the relationship between velocities of the image features in image space and robot end effector in Cartesian space is represented by

$$\dot{x} = Z^{-1}(q)L(r)\dot{r} \quad (30)$$

Note that both $Z(q)\dot{x}$ and $L(r)\dot{r}$ in equation (30) are linear in sets of kinematic parameters $\theta_L = (\theta_{L1}, \dots, \theta_{Lq})^T$ and $\theta_z = (\theta_{z1}, \dots, \theta_{zj})^T$, such as camera intrinsic and extrinsic parameters. Hence, $Z(q)\dot{x}$ and $L(r)\dot{r}$ can be expressed as, [14]

$$Z(q)\dot{x} = Y_z(q, \dot{x})\theta_z, \quad (31)$$

$$L(r)\dot{r} = Y_L(r, \dot{r})\theta_L, \quad (32)$$

where $Y_z(q, \dot{x})$ is called the depth regressor matrix and $Y_L(r, \dot{r})$ is called the camera regressor matrix. Although both $Z(q)$ and $L(r)\dot{r}$ are linear in kinematic parameters, the overall Jacobian matrix $Z^{-1}(q)L(r)$ is not linearly parameterizable because it is *inversely proportional* to the depths and hence the kinematic parameters in the image Jacobian cannot be extracted to form a lumped kinematic parameter vector.

In the presence of uncertainty in the image Jacobian matrix, the vision based controller is proposed as follows:

$$\tau = -K_v\dot{q} - J_m^T(q)k_{pr} \max(0, f_r(r)) \left(\frac{\partial f_r(r)}{\partial r}\right)^T + J_m^T(q)\hat{J}_I^T(x, \hat{\theta}_L, \hat{\theta}_z)k_{px} \min(0, f_x(\Delta x)) \left(\frac{\partial f_x(\Delta x)}{\partial x}\right)^T + g(q)$$

where $\hat{J}_I^T(x, \hat{\theta}_L, \hat{\theta}_z) = \hat{L}^T(x, \hat{\theta}_L)\hat{Z}^{-1}(q, \hat{\theta}_z)$ is an adaptive image Jacobian matrix, $\hat{\theta}_L$ denote the estimated parameters of the image Jacobian, $\hat{\theta}_z$ represent the estimated depth parameters. The estimated parameters $\hat{\theta}_L$ and $\hat{\theta}_z$ are updated using the following update laws:

$$\dot{\hat{\theta}}_L = -L_L Y_L^T(r, \dot{r})\hat{Z}^{-1}(q, \hat{\theta}_z)k_{px} \min(0, f_x(\Delta x)) \left(\frac{\partial f_x(\Delta x)}{\partial x}\right)^T$$

$$\dot{\hat{\theta}}_z = L_z Y_z^T(q, \dot{x})\hat{Z}^{-1}(q, \hat{\theta}_z)k_{px} \min(0, f_x(\Delta x)) \left(\frac{\partial f_x(\Delta x)}{\partial x}\right)^T$$

where L_L, L_z are symmetric positive definite matrices.

The Lyapunov-like function is proposed as:

$$V = \frac{1}{2}\dot{q}^T M(q)\dot{q} + P_r(r) + P_x(x) + \frac{1}{2}\Delta\theta_L^T L_L^{-1}\Delta\theta_L + \frac{1}{2}\Delta\theta_z^T L_z^{-1}\Delta\theta_z. \quad (33)$$

Differentiating equation (33) with respect to time and substituting the closed-loop equation into it, we can show that

$\dot{V} = -\dot{q}^T K_v \dot{q} \leq 0$. Since $\dot{V} = 0$ implies $\dot{q} = 0$ as $t \rightarrow \infty$, the following maximum invariant set [19] is satisfied

$$J_m^T(q)k_{pr} \max(0, f_r(r)) \left(\frac{\partial f_r(r)}{\partial r}\right)^T - J_m^T(q)\hat{J}_I^T(x, \hat{\theta}_L, \hat{\theta}_z)k_{px} \min(0, f_x(\Delta x)) \left(\frac{\partial f_x(\Delta x)}{\partial x}\right)^T = 0$$

Hence $\min(0, f_x(\Delta x)) \left(\frac{\partial f_x(\Delta x)}{\partial x}\right)^T = 0$ and $\dot{q} = 0$ if $J_m(q)$ and $J_m^T(q)\hat{J}_I^T(x, \hat{\theta}_L, \hat{\theta}_z)$ are of full rank. As seen from equation (23), this implies that $\Delta x \rightarrow 0$ in Ω as $t \rightarrow \infty$.

IV. EXPERIMENTS USING SHADOW FEEDBACK

Recent psychophysical evidence by Pavani and Castiello [20] suggests that our brains respond to our shadows as if they were another part of the body. This implies that body shadows may form part of the approximate sensory-to-motor transformation of the human motor control system. We implemented the proposed controller using visual feedback of the robot shadow. The joint motors of the robot are driven by amplifiers. The amplifiers are connected to a servo I/O card. The servo I/O card is an ISA-bus based general purpose data acquisition card. Each joint position is measured by an incremental encoder attached to the motor end. The counter outputs are read by a computer serving as the controller in which one Pentium III 450 MHz processor and 128 MB DRAM are installed. The control signals are fed through the digital-to-analogue converters of the servo I/O card to the amplifiers. The experimental setup consists of a camera, a light source and a SONY SCARA robot as shown in figure 4. An object was attached to second joint of the robot and was parallel to the second link. A robot's shadow was created using the light source and projected onto a white screen. The camera was located at a distance away from the screen and the tip of the object's shadow was monitored by the camera (see figure 4).

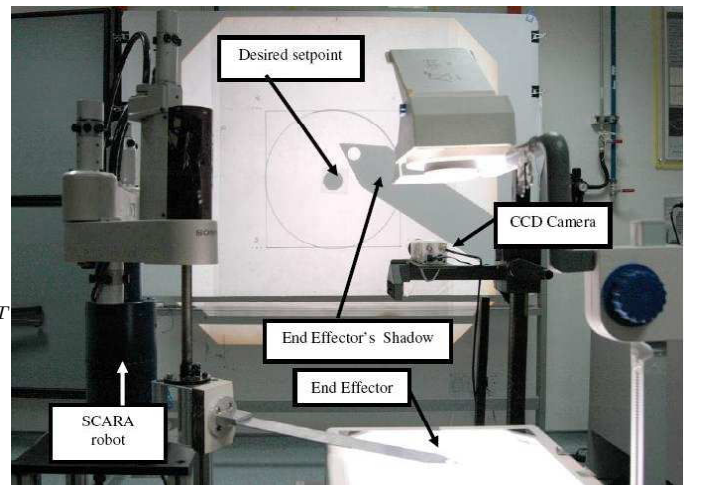

Fig. 4. A SONY Robot with its Shadow

A desired position was defined in image space as $x_d = [110, 107]^T$ pixels and a vision space region was then defined

as a circle with a radius of 33 pixels, around the desired position. The vision feedback was only used when the robot's shadow enter this vision region. To move the end effector toward the vision region without vision feedback, a circular region in Cartesian space was defined with a centroid of $[-0.67, -0.73]^T$ m and a radius of 0.05 m. A Cartesian-space controller was used when the end effector was outside the vision region and the lengths of the links were estimated as $l_1 = 0.35\text{m}$, $l_2 = 0.25\text{m}$. The experimental result in figure 5 shows the path of the end effector in Cartesian space. Figure 6 shows the position of the robot's shadow when the end effector enters the vision region.

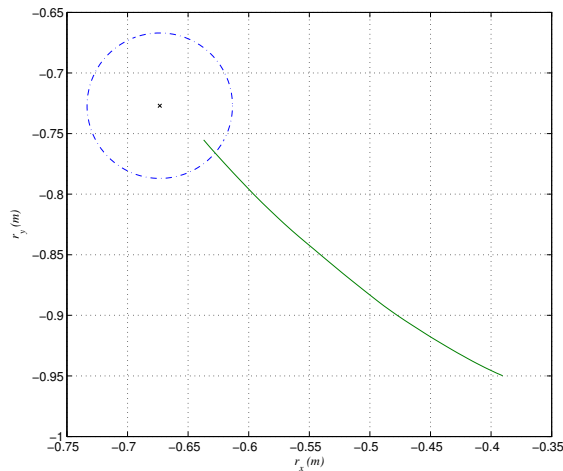

Fig. 5. Path of the end effector using Cartesian space reaching control

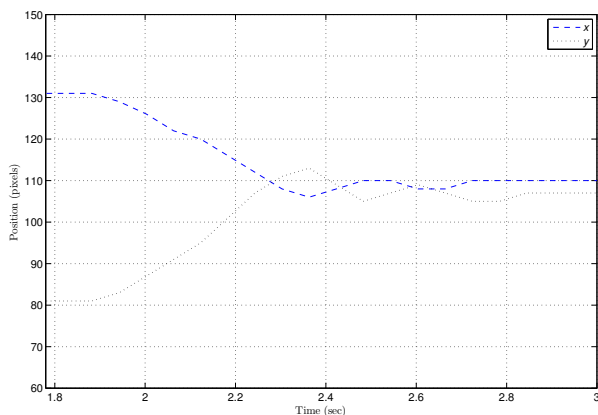

Fig. 6. Position of the end effector after entering visual region

V. CONCLUSION

In this paper, we have present a new task-space control strategy that allows the use of dual task-space information for a task. It is shown that the proposed task-space controller can transit smoothly from Cartesian-space feedback at the

initial stage to vision-space feedback at the end stage. The controller is inspired from human reaching tasks where we do not track our hand using vision for the entire task but only when it is near the target. The proposed controller is implemented on an industrial robot and experiment results are presented.

REFERENCES

- [1] M. Takegaki and S. Arimoto, "A new feedback method for dynamic control of manipulators," *ASME J. of Dynamic Systems, Measurement and Control*, vol. 102, pp. 119–125, 1981.
- [2] S. Arimoto and F. Miyazaki, "Stability and robustness of PID feedback control for robot manipulators of sensory capability," in *International Symposium on Robotics Research*, pp. 783–799, 1983.
- [3] S. Arimoto, *Control Theory of Non-Linear Mechanical Systems*. Oxford University Press, 1996.
- [4] R. Kelly, "Regulation of manipulators in generic task space: An energy shaping plus damping injection approach," *IEEE Trans. on Robotics and Automation*, vol. 15, pp. 381–386, 1999.
- [5] C. C. Cheah and H. Liaw, "Inverse Jacobian Regulator with Gravity Compensation: Stability and Experiment", *IEEE Trans. on Robotics*, vol. 21, no. 4, pp 741–747, 2005.
- [6] C. C. Cheah, S. Kawamura, and S. Arimoto, "Feedback control for robotic manipulators with an uncertain Jacobian matrix," *Journal of Robotic System*, vol. 12, no. 2, pp. 119–134, 1999.
- [7] C. C. Cheah, M. Hirano, S. Kawamura, and S. Arimoto, "Approximate jacobian control for robots with uncertain kinematics and dynamics," *IEEE Trans. on Robotics and Automation*, vol. 19, no. 4, pp. 692–702, 2003.
- [8] W. E. Dixon, "Adaptive regulation of amplitude limited robot manipulators with uncertain kinematics and dynamics," in *IEEE Transactions on Automatic Control*, (Boston, USA), vol. 52, no. 3, 488–493, 2007.
- [9] C.C. Cheah, D.Q. Wang, and Y.C. Sun "Region Reaching Control of Robots," *IEEE Trans. on Robotics*, Vol. 23, No. 6, pp 1260-1264, Dec 2007.
- [10] S. Hutchinson, G. Hager and P. Corke, "A tutorial on visual servo control," *IEEE Trans. on Robotics and Automation*, vol. 12, no. 5, pp. 651 – 670, 1996.
- [11] E. Malis and F. Chaumette, "Theoretical improvements in the stability analysis of a new class of model-free visual servoing methods", *IEEE Transactions on Robotics and Automation*, Vol. 18, No. 2, pp 176-186, April 2002.
- [12] B. Espiau, "Effect of camera calibration errors on visual servoing in robotics," in *Proc. of International Symposium on Experimental Robotics*, (Kyoto, Japan),r 1993.
- [13] E. Malis, "Visual servoing invariant to changes in camera intrinsic parameters", *IEEE Transaction on Robotics and Automation*, Vol. 20, No. 1, pp 72-81, 2004.
- [14] C. C. Cheah, C. Liu and J.J.E. Slotine, "Adaptive Vision based Tracking Control of Robots with uncertainty in Depth Information", *Proc. of IEEE Int. Conference on Robotics and Automation*, (Rome, Italy), pp 2817-2822, 2007.
- [15] Y.H. Liu, H. Wang, C. Wang; K.K. Lam, "Uncalibrated visual servoing of Robots using a depth-independent interaction matrix", *IEEE Transactions on Robotics*, Vol. 22, No. 4, pp 804 - 817, 2006.
- [16] F. L. Lewis, C. T. Abdallah, and D. M. Dawson, *Control of Robot Manipulators*. New York: Macmillan Publishing Company, 1993.
- [17] L. E. Weiss, A. C. Sanderson and C. P. Neuman, "Dynamic sensor-based control of robots with visual feedback," *IEEE Trans. on Robotics and Automation*, vol. RA-3, no. 5, pp. 404 – 417, 1987.
- [18] B. Espiau, F. Chaumette and P. Rives, "A new approach to visual servoing in robotics", *IEEE Trans. on Robotics and Automation*, Vol. 8 , No. 3, pp 313 - 326, 1992.
- [19] J. J. E. Slotine and W. Li, *Applied nonlinear control*. Englewood Cliffs, New Jersey: Prentice Hall, 1991.
- [20] F. Pavani and U. Castiello, "Binding personal and extrapersonal space through body shadows", *Nature Neuroscience*, vol. 7, pp. 14 - 16, 2004.