

A Technoregulatory Analysis of Government Regulation and Oversight in the United States for
the Protection of Passenger Safety in Commercial Human Spaceflight

by
Michael Elliot Leybovich

B.S. Engineering Physics
University of California at Berkeley, 2005

Submitted to the Department of Aeronautics and Astronautics and
the Engineering Systems Division
in partial fulfillment of the requirements for the degrees of

Master of Science in Aeronautics and Astronautics
and
Master of Science in Technology and Policy

at the
Massachusetts Institute of Technology
February 2009

© 2009 Massachusetts Institute of Technology. All rights reserved.

Signature of author:

Department of Aeronautics and Astronautics
Technology and Policy Program
December 22, 2008

Certified by:

Professor David A. Mindell
Professor of Engineering Systems & Dibner Professor of the History of Engineering and Manufacturing
Thesis Supervisor

Certified by:

Professor Dava J. Newman
Professor of Aeronautics and Astronautics & Engineering Systems, MacVicar Faculty Fellow
Thesis Supervisor

Accepted by:

Professor Dava J. Newman
Director of Technology and Policy Program

Accepted by

Professor David L. Darmofal
Chair, Committee on Graduate Students, Department of Aeronautics and Astronautics

A Technoregulatory Analysis of Government Regulation and Oversight in the United States for
the Protection of Passenger Safety in Commercial Human Spaceflight

by

Michael Elliot Leybovich

B.S. Engineering Physics
University of California at Berkeley, 2005

Submitted to the Department of Aeronautics and Astronautics and the Engineering Systems Division
on December 22, 2008 in partial fulfillment of the requirements for the degrees of
Master of Science in Aeronautics and Astronautics and
Master of Science in Technology and Policy
at the Massachusetts Institute of Technology

ABSTRACT

Commercial human spaceflight looks ready to take off as an industry, with “space tourism” as its first application. Paying passengers are likely to begin taking suborbital spaceflights within the next several years, both despite and because of the risks and hazards inherent in human spaceflight. As this activity poses dangers to passengers, there will be an increasing degree of government regulation and oversight to protect participant safety. Though human spaceflight is not a new endeavour, commercial human spaceflight poses a new set of challenges for regulators to grapple with. As is the case with many emerging technological industries, the regulatory challenge is to protect the safety of both participants and the uninvolved without regulating to a degree that stifles industry innovation and growth. This thesis examines the history and regulation of commercial human spaceflight to date. The technical background, systems engineering, and risk management of human spaceflight are explored, to determine which particular subsystem-mission phase combinations warrant closer regulatory attention. Finally, this paper gives recommendations on how future regulation of this nascent industry ought to be approached by the federal government and its regulatory agencies.

Thesis Supervisor: Professor David Mindell
Professor of Engineering Systems & Dibner Professor of the History of Engineering and Manufacturing
Director of Program in Science, Technology and Society

Thesis Supervisor: Professor Dava Newman
Professor of Aeronautics and Astronautics & Engineering Systems, MacVicar Faculty Fellow
Director of Technology and Policy Program

ACKNOWLEDGMENTS

Many thanks to my thesis advisors, Professors David Mindell and Dava Newman, for their guidance and support as I learned to be a scholar. David's ability to lead me to ask the right questions and Dava's multidisciplinary inspiration and optimism have made this thesis possible.

Thank you to the fine staff, faculty, and students of the Technology and Policy Program and the Department of Aeronautics and Astronautics for keeping me focused, learning, and laughing during my time at MIT. Special thanks to Sydney Miller, Yoko Urano, Shane Selleck, and Ed Ballo of TPP, and Barbara Lechner, Marie Stuppard, Beth Marois, and Sally Chapman of Aero-Astro. Also, thank you to my fellow students Jordan Peck, Jeff McAulay, Kenny Kamrin, Lisa Messeri, and Wilfried Hofstetter with whom I have been able to talk about my ideas and receive helpful feedback whenever I hit a dead end.

Much appreciation to the members of the Space, Policy, and Society research group who have helped me to expand my horizons in space policy. Thanks to Professor Jeff Hoffman, Professor Larry Young, Professor Annalisa Weigel, Dennis Shapiro, and Larry McGlynn. Special thanks to Dr. Scott Uebelhart, who was a valuable sounding board, officemate, and friend during this process. Also many thanks to the staff who have supported SPS, including Sarah Fowler, Danielle Mancini, Paree Pinkney, Kim Cowperthwaite, and Rose Rizzo.

Grateful thanks to the analysts at The Aerospace Corporation, with whom I have shared a similar research topic and from whom I have received very salient advice and valuable information. Special thanks to Bob Seibold, Jim Vedda, and Jay Penn.

A special thank you to a few individuals who agreed to let me interview them and pick their brains about this topic, especially Casey Dale, Gary Trudeau, and Tim Hughes. Thank you also to TPP alum Todd Curtis of AirSafe, who reviewed my draft in detail and provided excellent analysis and helpful suggestions.

Thank you to the MIT Libraries and librarians, who never ceased to amaze me with what they were able to help me find.

Finally, most special thank you to my inspirational parents Izzy and Larissa Leybovich, amazing sister Jenny Leybovich, and good friend Kate Barnes, who encouraged me along the entire path, never showed anything but confidence in me, and taught me the most important things I know.

TABLE OF CONTENTS

List of Tables	6
List of Figures	6
Chapter 1: Introduction	8
1.1 Dramatization	8
1.2 Background	10
1.3 Problem statement	12
1.4 Roadmap.....	13
Chapter 2: Regulation and risk background.....	14
2.1 Government regulation.....	15
2.2 Risk and safety	21
2.3 Technological risk and disaster	28
2.4 Adventure sports.....	29
Chapter 3: History and regulation of commercial human spaceflight	33
3.1 Commercial aviation regulatory history	33
3.2 Commercial spaceflight history.....	36
3.3 Commercial human spaceflight history to present	37
3.4 Commercial human spaceflight regulatory history	41
Chapter 4: Risk and safety in commercial human spaceflight.....	46
4.1 Definitions	46
4.2 Space system design.....	48
4.3 Space system operation	55
4.4 Incidents and accidents in human spaceflight	61
4.5 Mission safety criticality	68
Chapter 5: Conclusions and recommendations	72
5.1 Summary	72
5.2 Conclusions and recommendations	75
5.3 Future work	78
References.....	80
Biography.....	92
Appendices.....	93
Appendix A: Acronyms.....	94
Appendix B: COUHES documentation.....	95
Appendix C: Tag cloud	96

LIST OF TABLES

Table 1: Rule types 18
Table 2: Air and space vehicle definitions..... 47
Table 3: Vehicle body types and tradeoffs 48
Table 4: Design tradeoffs for suborbital space vehicles 49
Table 5: Suborbital CHS company systems..... 49
Table 6: Mission phase definitions and physical stresses: chronological 55
Table 7: Specific Impulses of chemical propulsion 57
Table 8: Incidents and accidents in human spaceflight chronologically 63
Table 9: Subsystems & mission phases, incidents & accidents, and criticality in HS 67
Table 10: Subsystems, mission phases, and criticality 69
Table 11: Subsystems & mission phases, incidents & accidents, and criticality in HS 71

LIST OF FIGURES

Figure 1: Mechanics of rule-making..... 17
Figure 2: The regulatory spectrum..... 20
Figure 3: History of US commercial aviation..... 35
Figure 4: Price elasticity: a market research comparison 39
Figure 5: Passenger demand forecast with different market maturation periods..... 39
Figure 6: Revenue forecast for suborbital space tourism..... 40
Figure 7: Types of X-15 research flights 51
Figure 8: X-15 flight paths in California 53
Figure 9: SpaceShipTwo flight profile 53
Figure 10: Modified X-15A-2 labeled schematic 54
Figure 11: Technical snapshot of Virgin Galactic’s SpaceShipTwo 54
Figure 12: Mission phase and physical stresses: graphical..... 56
Figure 13: Functional diagram of the X-15 stability augmentation system..... 58
Figure 14: Incidents and accidents in human spaceflight by mission phase..... 66
Figure 15: Incidents and accidents in human spaceflight by percentages 67
Figure 16: Safety criticality breakdown..... 70

CHAPTER 1: INTRODUCTION

1.1 Dramatization

The sun rises over the flat New Mexico horizon and the first rays of morning shorten the shadows below. From a birds-eye view, there is a bright glint from the ground as light reflects off of the gleaming hull of the craft emerging from the hangar.

The vehicle heading towards the long runway stretching out into the desert is really two flying machines held together, each designed and suited for a specific purpose. The larger machine on top appears to be cradling the smaller, blunter vehicle below its wing as if to protect it before releasing its companion to embark on its own flight.

The serene scene reflected in the windows of the buildings that the craft taxis past is, as is not unusual in this stage of the mission, unreflective of the more nervously raucous chatter echoing within the double-paned walls of the smaller vehicle. “Don’t worry ‘bout a thing, darlin’,” says the gregarious ex-Navy woman to the increasingly pale and sweating young cinema heartthrob, “the waiting’s the worst part!”

“Man, I don’t know about you guys, but I am so excited to take off! This is it!” exclaims the successful software developer to the rather reserved Russian businessman, as he glances behind to his other two co-passengers and bounces to a boil excitedly beneath his safety harness. As the dual vehicle reaches the start of the runway and glides to a pause, the four soon-to-be astronauts hear the pilot up front running through final checklists in preparation for takeoff.

With a cheery warning from the pilot to the passengers, the aircraft and spacecraft together quickly begin accelerating down the runway, picking up speed with each passing moment. Within a few seconds, the passengers all feel the familiar gentle lurch of the stomach as the system takes off and begins leaving the ground behind. The passengers gaze out the windows in rapt attention to judge how high they are climbing.

At an altitude above those reached by commercial jets, and already above the thickest parts of the atmosphere, the passengers are notified shortly before their smaller craft detaches from its carrier and begins to freefall. The pleasant, light sensation of the drop is replaced within a few seconds with the bone-jarring, tooth-rattling kick of energy that jerks through the vehicle as the rockets ignite and the craft takes a decidedly more vertical trajectory. This jolting feeling is surprisingly more energetic than expected to even the two passengers who had participated in the recommended training camp prior to flight.

The numbers on the digital altitude display increase rapidly and the passengers are tightly pressed into their seats by the acceleration. The former sailor manages a muffled whoop as the craft reaches Mach 1 and powers through the sonic boom on its way to a sky that is blacker than any that the passengers had ever seen. Then, as abruptly as it began, the rocket cuts out and the spacecraft soon begins a lazy drift over the top of its suborbital trajectory arc.

As soon as the pilot indicates that the passengers are “free to move about the cabin,” each in turn unbuckles themselves from his or her seat and gleefully begins to fly and flip within the enclosed and protected space. The businessman, dubbed the mission’s “assistant commander” by the pilot thanks to the premium he had negotiated to pay for the honor, reaches into his jacket pocket to pull out and open a small bag of specially-commissioned M&Ms, and the passengers delight in hunting them down with their mouths wide open as they float about the cabin. Even the young actor, inwardly terrified through the first stages of the flight, and initially even reluctant to leave his seat once it was permitted, smiles as he captures a renegade chocolate that he spies floating by his face.

Though they feel as though they could float and gaze out the windows at the curvature of the Earth and its thin band of blue atmosphere forever, the few minutes quickly pass and the pilot announces that it is time to return to their seats for reentry and landing. The computer programmer, having waited his entire life for this moment since dreaming of exploring space like his childhood heroes, is reluctant to be ripped from his gripping view at the main observation window to return to his seat. Not until a stern call from the pilot and a sincere plea from the “assistant commander” does he resignedly turn to float back to his seat.

Suddenly, the lights in the cabin go black and the whirring noises of the subsystems around them begin to fade. The passengers are confused as a red warning light begins to flash, and the software developer struggles to get strapped back into his seat amid the discord. This is nothing that they had anticipated, or which had been suggested in the promotional videos. The pilot quickly counsels the passengers to stay calm, but his words do little to soothe their worries as the cabin temperature begins to increase and a faint acrid smell hits their nostrils. Though the ex-sailor has been in tighter jams before, she begins to wonder if this spaceflight operator was the right choice as descent continues: chaotic, and clearly not nominal.

1.2 Background

A safety-threatening event such as just described, despite the best efforts of commercial human spaceflight (CHS) companies, may come to pass in one of a million different ways. It is not morbid or pessimistic to consider the potential failings of a new and exciting, if unproven, industry. Imagining the worst-case scenarios is a necessity if CHS is to succeed.

Human spaceflight (HS) has, since its inception, largely been the province of national governments. Only well-funded and large-scale programs, sponsored thus far by the United States (US), Union of Soviet Socialist Republics (USSR)/Russia, and China, could possibly meet the technical, economic, political, and regulatory challenges of sending human beings into space. Spurred primarily by geopolitical considerations of national prestige through impressive technological accomplishments, the competing government space exploration programs of the US and USSR engaged in a “space race” through the 1960s, with the Apollo moon landings as the pinnacle of accomplishment.

Since that time, the three spacefaring nations and their international partners have not ventured past low Earth orbit, focusing instead on space stations, international cooperative projects, and use of the Space Shuttle and Soyuz to access space. While there have been major accomplishments in this era, public interest and support has waned significantly since Apollo. Current public disenchantment with government-led HS in the US can be traced to several factors, including 1) a remade geopolitical paradigm after the fall of the Soviet Union, 2)

budgetary challenges stemming from fluctuating economies and entitlement programs leaving less funding available for discretionary government spending, and 3) catastrophic accidents that have resulted in loss of life, drained resources, and suspended HS for years at a time.

The US government HS program has suffered from lack of direction and purpose, and currently fails to excite the average American. The National Aeronautics and Space Administration (NASA) is not a defective organization, but it has for decades felt the frustration of being too important for the government to give up altogether, while not prioritized highly enough to be allocated the resources necessary to do work that excites the nation. For the children who grew up watching men land on the moon, the present lack of Martian colonies represents a failure of NASA to realize their future technological and exploration fantasies.

CHS, in its initial application of “space tourism,” is hoping to fill the excitement gap. The dream of comparatively more affordable, regular, personal access to space has been a long-awaited step in the progress of HS, and it is nearing possibility due to the efforts of a few enterprising companies with wealthy and patient benefactors. The suborbital flights soon to be offered are somewhat short of the once-promised Pan Am journey to the moon¹, but these efforts could represent the beginning of a new era in HS.

While HS has been happening since 1961, CHS is a new industry because of its unique characteristics. CHS brings a set of several smaller-scale actors to the scene compared with government HS programs. These companies have smaller budgets, smaller workforces, less diverse mission portfolios, and much less direct government oversight that do the government-run programs. The fundamental goal of a CHS company is to eventually turn a profit, rather than to seek geopolitical prestige or further planetary exploration and space science, and funding sources are different, with accountability to investors rather than to national governments.

This enterprise faces myriad technical challenges, with mission and life safety as critical to success as the economic efficiency required to be commercially sustainable. The required

¹ da Silva, W. (2006, December). *Children of Apollo*. Retrieved July 22, 2008, from Cosmos Magazine: <http://www.cosmosmagazine.com/features/print/1163/children-apollo>

seamless integration of subsystems over all phases of flight is no simple task. There are many things that can go wrong, between the 1) explosive energies required to reach space, the 2) unforgiving harshness of the space environment, and the 3) history of tragic accidents occurring even under careful control of the best personnel. Given the potentially disastrous consequences of these hazards, some sort of government safety regulation was inevitable.

For CHS, the regulatory framework is already being built before the operational beginning of the industry. This is especially true as compared with other high-risk recreational activities which are generally not regulated until government regulatory bodies become aware of their existence following their grass-roots evolutions. Because of CHS's prominent place in the public eye as compared to most new industries, and potential for significant damage to the uninvolved public if a mission should go awry, government regulation and oversight began relatively early. The long start-up time between public announcements of CHS companies and their maiden commercial voyages has provided plenty of time for governments to craft regulation and oversight policies that seek to prevent accidents.

The way that the US government will approach regulation protecting the safety of passengers in the long run is still being determined. Congress last passed related legislation in 2004, with the idea that CHS might be up and running as an industry by as early as 2006. This legislation delayed issuing design or operations rules protecting passenger safety in order to give the industry time to innovate and experiment with different concepts of operation. This way, best practices could emerge before setting on rules that could lock in certain design and operational features. As of 2008, the industry looks poised to not have its inaugural flights until perhaps 2010. CHS companies would like to avoid stricter regulation as long as possible, while other interested parties think it is already long overdue.

1.3 Problem statement

How to regulate CHS to protect passenger safety is a question that still has no definite answer. There is a scarcity of data available to regulators at present, which limits the ability to predict future trends. This thesis will synthesize an approach with an examination of risk and

regulatory theory, history of HS, CHS, and relatable industries such as “adventure sports”, and specific technical aspects of CHS that can be targeted for closer oversight. This will allow us to craft recommendations to policy-makers about passenger safety regulation in CHS. It is the conclusion of this thesis that federal regulators can best assure maximum welfare for the industry and public by regulating design and operations in a fashion that targets only the most critical mission phase-subsystem combinations, and avoiding making across-the-board rules until there are enough viable companies operating to make generalizations efficient and meaningful.

1.4 Roadmap

This thesis will address this problem by building upon the work of other scholars and deploying original analysis to add value to the discussion. After this introduction in Chapter 1, Chapter 2 will delve into the theoretical background of both government regulation and risk and safety literature. This will set the theoretical stage for a discussion of regulation by government of risk and safety in CHS. Chapter 2 also posits adventure sports as an analogy to CHS.

Chapter 3 will further the discussion with a detailed history of CHS from its origins to the present. It begins with a review of the history of commercial aviation and its regulatory system and is followed by the history of commercial space (CS) leading to CHS.

Chapter 4 gives a risk and safety background of CHS so that the regulatory regimes discussed can be technically informed and relevant. Included in this chapter are precise definitions that we will use with regards to CHS and space, different approaches to design, and cross analysis of mission phases and critical subsystems. Actual relevant incidents and accidents in the history of HS are examined to identify where risk and safety is most critical.

Chapter 5 concludes the entire discussion with a concise summary of the previous chapters and several conclusions. Recommendations are then given as to how regulation of passenger safety in CHS might proceed in a way that will ensure safety while not stifling innovation among entrepreneurial companies.

CHAPTER 2: REGULATION AND RISK BACKGROUND

There is at once a rich and lacking body of literature available upon which to build this research. Government safety regulation of CHS is very new, and there is little available academically about government safety regulation of existing high-risk recreational activities. However, there abound volumes of scholarly literature about government regulation, risk, and safety. In this body of work we will find that targeted government regulation of risk and safety is best for small, emerging industries. The optimal method is for Congress to delegate authority to independent agencies to both assess and manage risk without contaminating the two responsibilities with one another or becoming controlled by the regulated industries.

The related theoretical work will illuminate potential approaches to a new problem. We will begin by examining government regulation theory and use of expert agencies. Following that, we will look at market failures and regulatory justifications. Next will be types of regulation, rule-making strategies, and regulatory consequences. Then we will discuss regulatory capture and self-regulation.

Next, we will examine literature about risk and safety. Beginning with a discussion of risk at the individual level, we will compare and contrast risk issues in theory, government, and adventure. We will then explore risk perception, risk assessment, risk communication, risk acceptance, informed consent, uncertainty, and risk management.

We will then look at the specific subsets of technological risk and disaster theory, followed lastly by an exploration of adventure sports as an analogy for CHS. Through the course of this literature review, we will discover where the gaps in the body of knowledge are that we may help to fill with this research.

2.1 Government regulation

2.1.1 Regulation theory and background

We will begin with an exploration of how and why governments regulate in the first place as a “normal activity of government in an industrialized, urbanized society” (Bernstein, 1955). This thesis focuses specifically on US government passenger safety regulation for CHS. The US’s regulatory system provides a rich field of study, having “virtually invented the modern regulatory state” (Moran, 2002). The power of government to enact any sort of regulation is based on Article I, Section 8, Clause 3 of the United States Constitution, which states, “The Congress shall have power . . . To regulate commerce with foreign nations, and among the several states, and with the Indian tribes.” From this “Interstate Commerce Clause”, Congress derives its power to enact a broad range of regulation, since nearly every modern industry has some interstate aspect.

The US government, through Congress and the power it delegates, has an enormous impact on industry, able to help or hurt a large number of industries (Stigler, 1971). Congress utilizes this power over most industries, trying in theory to protect the public good. While Congress has broad power, it is limited in the amount of detailed oversight it can provide. There is simply not enough time or resources between 435 Representatives, 100 Senators, and their staffs, to provide the requisite support to, and oversight of, each industry.

As the United States became an industrialized nation, the first independent oversight agency created by Congress was the Interstate Commerce Commission (ICC) in 1887. It served as an experiment in government-industry relations, with Congress adopting a hands-off approach to reform policy (Bernstein, 1955). The ICC was weak at first because of limited enforcement mechanisms, but grew in power and scope through the years, retaining a relatively independent status. The ICC became a model for later independent regulatory agencies.

2.1.2 Agency regulation

One of the major benefits that an independent regulatory agency provides is a deep level of technical expertise and sophisticated understanding of an industry (Bernstein, 1955). The regulators maintain closer ties with industry and greater concentration of expertise than would be possible by Congress (Ogus, 2002). With detailed focus and analysis, however, come limitations of scope, power, and expediency. Slow-acting, commission-based regulation is a precise tool that is limited in its functionality (Eisner, 1993).

The independent agency model of government regulation is constructed to satisfy a wide variety of stakeholders, including Congress and the industries themselves (Bernstein, 1955). These players find broadly distributed power most beneficial to their own interests. This allows Congress more influence than if a regulatory body were centralized in the executive branch. It allows industry more flexibility and understanding from the government than if the regulatory bodies were not as independent and expert-based. The system also satisfies politicians who would rather not make difficult choices that may alienate one interest group or another (Ogus, 2002). Agencies, however, are not removed from politics, and a balance must be struck between providing pure technical expertise and recognizing the reality that agencies are led by political appointees (Kohlmeier, 1969).

Agencies must also remain responsive to public concern “heard in adversary proceedings” or else face problems with Congress (Hilton, 1972). Some ways of assuring accountability are collecting citizen comments, requirements of outside consultation, and publication of major decisions. An independent regulatory agency, while not controlled directly by its legislative and executive stakeholders, is also accountable to their requests for process transparency (Ogus, 2002).

Regulation is a two-way street, serving regulators and industry alike. Regulation serves industry because the scrutiny involved in regulation confers legitimacy to the industry (Shaffer, 1995). Without a trusted third party expert declaring that an industry’s products are safe, public

purchasing skepticism would be much higher. By weaving together the motivations of industry and regulators, a mutually beneficial regulatory paradigm is achieved (McCraw, 1984).

But is regulation always necessary? Can governmental bodies be too eager to regulate? Those with a strict market perspective would contend that regulation should only be turned to in the case of market failure (Ogus, 2002), which stems from a mismatch of stakeholder incentives and behaviors (Wolf, 1978). When this is the case, regulatory bodies are called upon to provide the proper incentives. There are several categories of market failure: monopolies, inadequate or asymmetrical information, externalities, and co-ordination problems.

2.1.3 Rulemaking

Regulatory intervention is never perfect, and no approach is guaranteed to succeed (Wolf, 1978). There are strategies on how to design rules, including questions that rule-makers should consider and pitfalls to avoid. Figure 1 shows the balance that regulators face:

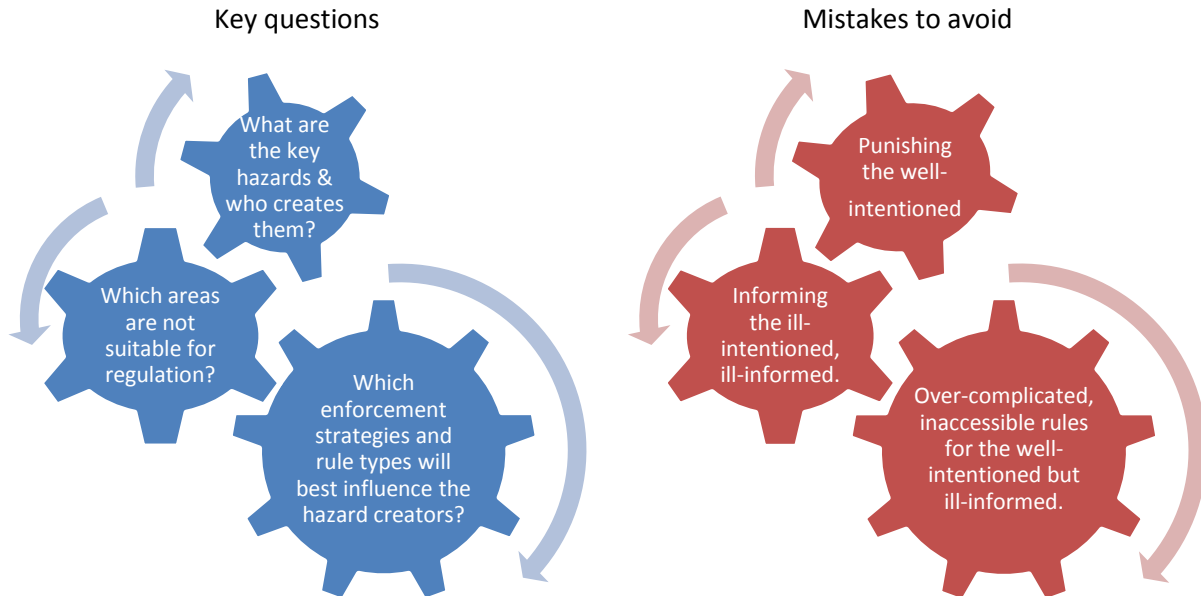

Figure 1: Mechanics of rule-making based on (Baldwin, 1990)

A regulatory body must remain flexible and open to change over time (McCraw, 1984). Circumstances, the public, and governments change, and firms adapt to regulation (Shaffer, 1995). The politics of regulation must also remain in a regulator’s mind, with an effective result being rationally, emotionally, and politically satisfying (Bernstein, 1955; Stone, 2002). Not every rule-type will fit every situation (Baldwin, 1990). Table 1 illustrates rule types versus requirements and costs.

Table 1: Rule types based on (Ogus, 2002)

Rule type	Requirements	Costs
Prior approval	Requirement of license from approving agency	<ul style="list-style-type: none"> • High administrative cost • Lost opportunity cost from approval delays • Can create social welfare cost of barriers to entry
Mandatory standards	Performance or specification standards	<ul style="list-style-type: none"> • Costs of being technologically informed as to feasibility of meeting standards goals • Administrative costs
Information disclosure	Disclose to purchasers of potential harms or risks of product	<ul style="list-style-type: none"> • No welfare losses from customers deprived of choice • Low administrative costs
Economic instruments	Tax or charge	<ul style="list-style-type: none"> • Optimally equal to consequences of undesired behavior • Conduct unconstrained, but firms must pay for undesired behavior

There are problems and benefits with centralized regulation. On one hand, it simplifies matters by reducing the number of rules that must be written, proposed, adopted, monitored, and enforced. However blanket policies can create outcomes that are less favorable to one segment of the population than another. Lastly, if only one regulatory scheme is available, it faces no competition and little incentive for experimentation.

2.1.4 Outcomes of regulation

While government regulation exists to protect the public, it seeks to avoid significantly retarding industrial growth (Eisner, 1993). Complaints about regulation often focus on it impeding “economic efficiency” (McCraw, 1984). Cost-benefit analyses may be used to evaluate regulation using objective criterion (Hahn, 1996) and tailored to each industry (Graham, 1996). The outcome may sway regulators to pursue alternative measures, if they buy the claim

that “more than half of the federal government's regulations would fail a strict benefit-cost test using the government's own numbers” (Hahn, 1998).

As the consequences of regulation may help create “winners” and “losers”, “the single constant in the American experience with regulation has been controversy.” (McCraw, 1984) Judgment of a regulatory body’s success in balancing efficiency and equitability (Stone, 2002) should be taken in their historical context (McCraw, 1984). Failure in regulation can be due to vague standards (Friendly, 1962), difficulty of understanding (Eisner, 1993), undisciplined enforcement (Lave, 1982), and inflexibility across contrasting situations (Baldwin, 1990).

Even where industry can see benefit from regulation, it is rare that regulation will be proposed without some amount of resistance (Bernstein, 1955). One reason that emerging technology industries resist is that they fear that too many rules too early will stifle innovation. This concern dates back to the 19th century when Congress puzzled with the dilemma of toughening railroad safety regulation without impeding development (McCraw, 1984).

While industries will often oppose government regulation, the regulatory mechanism is generally influenced by industry interest groups (Bernstein, 1955; Shaffer, 1995) and may even end up “captured” by the regulated (Stigler, 1971). The types of regulatory contributions and powers that an industry may seek from government are increased difficulty of entry by new competitors (McCraw, 1984), direct money, policy over “substitutes and complements”, and the fixing of prices (Stigler, 1971).

2.1.5 Self regulation

Government regulation ranges in degrees of control, from no regulation to full government ownership, and many steps in-between. Several grades are displayed in Figure 2 on the next page, which summarizes Garvin’s regulatory spectrum.

One regulatory option on the spectrum with a smaller degree of direct government control is self regulation (SR), which in its pure form is just slightly more restrictive than no

regulation at all. We will adopt the definition of SR as “a regulatory process whereby an industry-level, as opposed to a governmental- or firm-level, organization (such as a trade association or a professional society) sets and enforces rules and standards relating to the conduct of firms in the industry.” (Gupta & Lad, 1983). SR also encompasses information disclosure, product rating, coding conduct, creating safety standards, and guarding against deception from firms (Garvin, 1983).

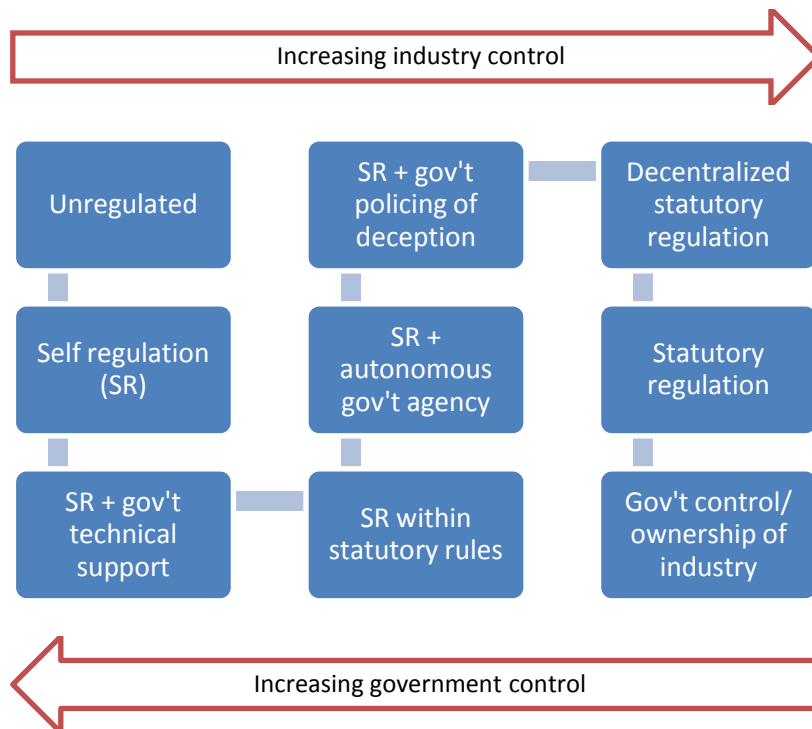

Figure 2: The regulatory spectrum based on (Garvin, 1983)

Certain conditions in an industry will make SR more appropriate and likely. One of these is effective internal governance (Doyle, 1997), such as a strong trade association which facilitates cooperation among firms (Gupta & Lad, 1983). External factors are important as well, such as strong incentives from both the public and private sectors to adopt SR (Gunningham & Rees, 1997). Market share stability is another important precursor (Garvin, 1983), as is allaying government anti-trust concerns (Hemphill, 1992) and being cost effective (Ogus, 1995).

The proper, non-fear-based (Nunez, 2001), incentives must exist to ensure SR in a way that increases the welfare of both industry and public (Maitland, 1985). Government incentives

such as less onerous inspections and preference in purchasing (Lenox & Nash, 2003), enable the prospect of industries “doing well by doing good.”

This system is only sustainable if firms truly earn these benefits and “adverse selection” (Akerlof, 1970) is avoided. SR bodies do not have the power of the state to “coerce” through taxation, seizure, and eminent domain (Stigler, 1971). However, mature trade associations sometimes serve as better mechanisms for enforcement, especially when they represent the large majority of firms and activity in the industry and can better assure compliance (Hemphill, 1992).

SR is “very rarely successful as a ‘stand-alone’ mechanism of social control.” (Gunningham & Rees, 1997) A mix between self and statutory regulation seems to offer the best combination of the positive traits that both have to offer, while offsetting each other’s weaknesses. SR includes the benefits of flexibility, cost savings, and more efficient information gathering. It also includes the weaknesses of barriers to entry, free-riding, and potential of reduced competition. The greatest weakness of SR is the difficulty of enforcing regulations, but this can be offset by government (Doyle, 1997). The governmental role can be either process-based (insuring “equitable procedures,” due process, and enforcement) or expertise-based (unbiased technical review, standards advising, and limited regulatory authority) (Garvin, 1983). Ultimately, the two systems can feed off of one another, with self regulation informing statutory regulation about industry-specific best practices (Hemphill, 1992).

2.2 Risk and safety

Before considering government regulation of risk and safety in high-risk recreational activities, we will discuss risk, adventure, and safety theory. Risk is the “potential to lose something of value” (Priest & Baillie, 1987), a combination of the “likelihood of an accident and the severity of the potential consequences” (Leveson, 1995). Adventure is “voluntary engagement in novel, uncertain, and most often emotionally intense recreational activity” (Holyfield, Jonas, & Zajicek, 2005). There are many sorts of adventure, each with different levels of risk and different participant motivations (Sung H. H., 2000). We will be considering

physical adventure that involves surrendering some or all control to equipment or professional guides in order for unskilled participants to be able to engage in the activity (Buckley, 2006).

The perception of safety is more flexible and contextual, as “a thing is safe if its attendant risks are judged to be acceptable.” (Lowrance, 1976) When considering safety and risk versus reward of an adventure activity, an individual must balance several factors, as must a governmental body in determining how to protect participant safety. To individual and government alike, the question is “how safe is safe enough?” (Fischhoff, Slovic, Lichtenstein, Read, & Combs, 1978)

2.2.1 Motivation of risk seeking

We first discuss the risk process on the individual level, to understand what motivates people to put themselves into danger in the pursuit of thrills (Mitchell, 1983). Participants in adventure tourism are most often 25-55 years old, have gone through higher education, are middle class or higher, and live and work in urban environments (Loverseed, 1997; Sung H. H., 2001; Gray, 2006). This set overlaps with the set of individuals likely to be early space tourists.

Participants in these dangerous activities choose to get involved because of anything from the search for youthful feelings to challenging mortality itself to pride and social standing (Gutman & Frederick, 2002). Adventure seeking is motivated by a combination of “identity construction” (Celsi, Rose, & Leigh, 1993), skill enhancement, community, and confidence of controlling the experience (Shoham, Rose, & Kahle, 2000). One subset of adventure motivation is the desire to gain prestige through activities that “should be unusual or exclusive, and perhaps inspire admiration or envy in others” (Swarbrooke, 2003). While some are motivated by at the end result, others approach adventure activities seeking novel and thrilling experiences (Jack & Ronan, 1998) that provide “relatively high levels of sensory stimulation” (Muller & Cleaver, 2000) removed from the participant’s natural environment (Sung, Morrison, & O’Leary, 1996).

2.2.2 Risk perception

Risk perception is critical in risk management (Cheron & Ritchie, 1982). In each risk choice and an individual's perception of it, there are a number of psychological factors at play, including trust, harm, control, choice, certainty, and familiarity². Risk perception is not consistent across the board, as people perceive risk to others differently than to themselves. Individuals may under-perceive risk, their "risk denial" leading to "unrealistic optimism" (Sjoberg, 2000). This sometimes causes individuals to assume more risk than they realize.

The calculation to determine the value to an individual of participation in a high-risk recreational activity is the product of motivational strength, probability of success, and incentive value (Atkinson, 1957). If an activity is deemed very high in value, even a lower probability of success may still result in an attempt. This internal process sorts out participants to activities and levels of risk and safety that are appropriate to their own values.

In adventure, risk perceptions are often skewed by individuals (Rossi & Cereatti, 1993), though perception can be managed by adventure operators³. Adventure operators can either talk risks up or down to enhance the participants' experience (Swarbrooke, 2003). Ultimately, we must consider all factors in risk perception as they will influence the individual looking to participate or government looking to regulate, regardless of how subjective those factors are (Rowe, 1988). For the next step in the risk process, we look at risk assessment.

2.2.3 Risk assessment and communication

The objective determination of risk probabilities is a critical component of overall risk assessment and management (Starr & Whipple, 1980; Haimes, 2004). It is highly technical and specific to each activity, and generally attractive as an unbiased measure of risk. However, it requires social context (Rowe, 1988). Risk assessment can be considered somewhat subjective,

² Antuñano, M. (2007, October 31). "Regulatory Medical and Safety Aspects of Space Tourism". MIT Space, Policy, and Society research group. Cambridge, MA, USA: Federal Aviation Administration.

³ Morrissey, S. (2008, March 3). *When Adventure Tourism Kills*. Retrieved March 4, 2008, from Time: <http://www.time.com/time/nation/article/0,8599,1718951,00.html>

as much “art” as “science” (Goldstein, 1996). The judgment required to assess risk requires a foot in the technical world as well as an understanding that the assessed level of risk may be taken by the public policy world as fact without discussion of uncertainty (Jasanoff, 1993).

Governmental bodies use risk assessment to determine how to respond to risks that may threaten public health and safety. As it is defined by National Research Council (NRC): “Risk assessment is the use of the factual base to define the health effects of exposure of individuals or populations to hazardous materials and situations.” (National Research Council, 1983). Some sort of risk assessment is critical if there is to be any sort of methodological basis to regulating risk (Lave, 1982). Risk assessment has in fact become an important tool for governmental regulatory bodies (Dudley & Hays, 2007).

Risk assessment is a prelude to risk management, both of which cannot be fully isolated from one another (National Research Council, 1983; Jasanoff, 1993). However, the two must not become too tangled, lest one adversely taint the mission of the other. Current government policy specifies that a clear distinction must be made between the two, if not a complete separation (Dudley & Hays, 2007). This distinction, allows independence without blindness.

Risk management includes risk communication, which should be clear, accurate, and objective (Dudley & Hays, 2007). There are challenges in relaying risk information, for the public may not understand technical details conveyed in probabilistic form (Nelkin, 1989). Complicating matters, the media is not exceptionally skilled at conveying these messages either, sometimes resorting to the sensational (Morgan M. G., 1993). However, despite the challenges of communicating risks, it is necessary to preserve transparency in the public interest.

2.2.4 Risk acceptance and uncertainty

Once risk is perceived, assessed, and communicated, the question of risk acceptance arises (Fischhoff, Lichtenstein, Slovic, Derby, & Keeney, 1981; Derby & Keeney, 1990). Voluntarily assumed risk, the subject of this thesis, is much different and better tolerated than involuntarily or unknowingly assumed risk (Fischhoff, Slovic, Lichtenstein, Read, & Combs,

1978; Viscusi & Zeckhauser, 1990), up to 1000 times more tolerated by one measure (Starr, 1969). However, even if an individual or group is willing to accept risks *carte blanche*, government may still attempt to impose protections (Rowe, 1988).

Risk need not always or ever be nonzero, as “risk is not always undesirable” (Abraham, 1986). Though risk generally carries a negative connotation, it may be considered a positive on occasion, and depends highly on context (Starr, 1969). This goes back to risk perception, where quantitative risk measures may not tell the entire story. Risk acceptance is very much a snapshot in time, with results in the present not necessarily corresponding to prior levels of risk acceptability or predictive of future trends (Otway, 1982).

In order to have any meaning in a policy environment, value must be assigned to risk in order to determine regulatory priorities. One way to assign value to various risks is through the potential benefits that taking such risks may accrue (Fischhoff, Slovic, Lichtenstein, Read, & Combs, 1978) and the potential downsides that may arise should the risk result in failure. Various relationships have been proposed, from risk acceptability as “crudely proportional to the third power of the benefits (real or imagined)” to measuring dread using the “psychological yardstick” of death from disease (Starr, 1969).

Risk is critical to the experience of adventure activities (Ewert A. W., 1989), to make them worth the participant’s “time, resources, energy, and possibly even health and life” (Mitchell, 1983). An attempt to remove too much risk from adventure may negate the reasons for the activity in the first place (Ryan, 2003). Even in high-risk situations, the high value of the adventure experience may overcome a potential participant’s aversion to risk (Meier, 1978). Each individual will establish their own risk-value mix (Ewert & Hollenhorst, 1989). Risk acceptance in adventure, while voluntary, must still be carefully managed and offered with an explicitness that matches the seriousness of the risk (Swarbrooke, 2003).

Such warnings are to make very clear the expectations and realities of the activity, and to clear up any misperceptions before the adventure commences. Informed consent is a type of risk acceptance, with a formalized informational and consent feedback mechanism, having begun in

the medical profession (Schuck, 1994). As a protection mechanism, it assures that individuals or groups who offer a risky product or service are protected as well.

2.2.5 Uncertainty

In any sort of system that assesses, accepts, and manages risks, there will be an element of uncertainty (Morgan & Henrion, 1990). This is especially true when considering risks inherent in emerging technologies, new industries, or ones with rare but catastrophic failures. For these activities, recognizing uncertainty is even more important as “good actuarial data” is typically not available (Morgan M. G., 1993). Individuals make better decisions when better informed, and industries that deal with hazardous uncertainties should be made to share with customers what they don’t know and where experts disagree (Fischhoff, Bostrom, & Quadrel, 1993). CHS fits this description, as there will be uncertainty for some time to come.

Including uncertainty in risk analysis allows use of limited data combined with expert judgment to make better decisions before better data is available. When judgment calls are made, “they should not be hidden but should be set forth carefully, openly, and explicitly,” with acknowledgment of significant expert disagreements when they exist (Morgan, Henrion, Morris, & Amaral, 1985). Doing so transparently allows an observer to assess on his or her own if those judgments are appropriate, and how the analysis might differ using other judgment calls.

2.2.6 Risk management

Once a risk has been assessed, communicated, and accepted, it can be managed it to protect public welfare. The first step is classifying how to approach the risk. Three approaches are “utility based” where pros and cons are scored, “rights based” which is based on justice, and “technology based” which calls for risk management as capable as current technology will allow (Morgan M. G., 1993).

Governmental regulatory bodies often seek to manage risk in some meaningful way. The NRC definition states: “Risk management is the process of weighing policy alternatives and

selecting the most appropriate regulatory action, integrating the results of risk assessment with engineering data and with social, economic, and political concerns to reach a decision” (National Research Council, 1983). The current Office of Management and Budget/Office of Science and Technology Policy guidelines state:

In making significant risk management decisions, agencies should analyze the distribution of the risks and the benefits and costs (both direct and indirect, both quantifiable and non-quantifiable) associated with the selection or implementation of risk management strategies. Reasonably feasible risk management strategies, including regulation, positive and negative economic incentives, and other ways to encourage behavioral changes to reduce risks (e.g., information dissemination), should be evaluated. Agencies should employ the best available scientific, economic and policy analysis, and such analyses should include explanations of significant assumptions, uncertainties, and methods of data development. (Dudley & Hays, 2007)

These guidelines are to help executive agencies serve the public. Public input should also play a role in crafting such guidelines by providing the values on which risk management decisions are based (Morgan M. G., 1993). The public also instigates regulation, as “government regulates whenever public pressure builds up to make it regulate” (Lowrance, 1976).

Risk management principles and objectives should be as clear as possible (Sapolsky, 1990). This task is sometimes confounded by legislative mandates that leave agency goals and objectives vague for political purposes (Derby & Keeney, 1990). Legislatively-granted authority that is “clear, feasible, and predictable” can lead to improved coordination and consistency (Fischhoff, Lichtenstein, Slovic, Derby, & Keeney, 1981).

As the number of people who crave greater “authenticity” in their recreational activities grows larger, adventure sports have an ever-expanding set of risk management issues. Adventure operators walk a fine line, with their clientele (particularly one-time thrill seekers) demanding the feeling of risk in their adventure experience but not wishing to be hurt as a result (McEwen, 1983; Holyfield, Jonas, & Zajicek, 2005; Gray, 2006). Proper safety design and operation can help to assure that this balance gets the best of neither operator nor participant.

2.3 Technological risk and disaster

Some risk issues are inherent to technology and the balance between benefits, risks, and uncertainty that new technology brings. While technology can bring countless benefits, it can also claim money and lives when it goes wrong (Fischhoff, Slovic, Lichtenstein, Read, & Combs, 1978). Short of ceasing the pursuit of new technologies, these risks must be dealt with. Managing technological risk is highly context-dependent, and should account for information available, values, stakeholders, politics, and historical background (Otway, 1982). Without the accompanying societal information, a purely technical risk analysis is unlikely to provide much benefit to the policymaker.

Technological risk is very difficult to manage because the course of an emerging technology is very difficult to predict (Jasanoff, 1986). Still, regulatory decisions must often be made with educated predictions that take into account potential future “scientific, economic, and technological events” (Lave, 1982). In these cases, uncertainty techniques will help to craft flexible and responsive regulatory schemes from limited information.

Some technological failings are catastrophic, qualifying as bona fide disasters. The causes of disaster may be manifold, ranging from poor management to conduct to unanticipated interactions in the functioning of a large, complex system (Turner, 1994). The feeling of routineness that develops over time in any system can prove fatal. In the case of the Challenger accident and its “normalization of deviance”:

The cause of disaster was a mistake embedded in the banality of organizational life and facilitated by an environment of scarcity and competition, and unprecedented, uncertain technology, incrementalism, patterns of information, routinization, organizational and interorganizational structures, and a complex culture. (Vaughan, 1996)

Disasters waiting to happen are inadvertently built into most complex systems, the result of “unanticipated and often baffling interactions” (Sagan, 1993). This class of disasters is known as “normal accidents” (Perrow, 1984). These interactions develop in six categories: design, equipment, procedures, operators, supplies and materials, and environment, and can be “tightly

coupled” (more time-dependent) or “loosely coupled” (less invariant). An accident is an “unintended and untoward event that causes damage sufficient to disrupt ongoing or future tasks” and involves complete subsystems or the whole system. An incident is a minor accident involving a part or unit.

Normal accidents are bound to occur because of the incomprehensibility of emergent disaster patterns that are most often only able to be clearly spotted and translated in hindsight (Perrow, 1984). Emergent systems must be carefully observed, and cannot be considered completely safe and reliable until the system has had the opportunity to cycle through a wide variety of situations. Any complex system may fail in an unexpected, rapid, and chaotic fashion that may be set off by just a minor, seemingly unrelated glitch (Faulkner, 2001).

The risk of disaster is present at an elevated level in adventure activities (Murphy & Bayley, 1989) and is even used to sell the activities (Palmer, 2002). Still, participants expect to be kept safe as they venture into harm’s way in adventure activities across the board. Comparing regulation, oversight, and risk-mitigation models between adventure industries yields valuable lessons for CHS participant safety protection going forward.

2.4 Adventure sports

To begin with a disclaimer, adventure sports fail as a model for space tourism on many counts. Comparing public safety protection between these two enterprises is not useful, as they face different technical challenges and consequences. If a sky diving parachute fails to deploy, for example, the only people likely to be injured or killed are the jumper and perhaps anyone unfortunate enough to be standing directly beneath. If, however, a spacecraft explodes, debris and toxic substances may rain down over a large area and cause a significant degree of damage.

Further, comparisons of the enterprises with one another on expense, technical complexity, public perception, or potential industry growth all proves false. Space tourism will be more expensive to build and participate in than adventure sports, relies on much more advanced technologies, is much more closely watched by the public given the few industry

players and the novelty of the industry, and may possibly grow one day into the foundation for more advanced applications such as space industrialization.

However, the comparison is quite apt in the case of protection of participant safety. In both instances, there are willing, voluntary participants who know that they will be engaging in an activity that is high-risk. Both adventure sports and space tourism require some non-negligible investment of money and time. When either goes badly, there is a significant chance of serious injury or death. Both offer activities that were initially only open to trained and skilled individuals, but are now open to a much larger population. Both also require basic physical health to participate and the guidance or complete custody of a trained operator.

In both adventure sports and space tourism, there may be dangerous information asymmetries, where the participant may not be keenly aware of all of the risk factors involved in the activity. Also, both are subject to regulation designed to protect even willing participants.

The adventure sports which are most closely related to space tourism in the areas of interest possess certain useful, analogous characteristics:

- Thought of as “risky” and “dangerous” by the general public. In one study, skydiving was even rated as more risky in an opinion survey than space travel (Futron, 2002)
- Unskilled individuals may participate
- Regulated by government authority in some ways to protect passenger safety

Three activities of the many in existence meet each of these criteria: bungee jumping, hang gliding, and sky diving. None are considered generally “safe” by the general public, though most people are welcome to participate without a great degree of training. While there are skill levels from novice to enthusiast to professional in each of these activities, in each may someone who is in reasonably good physical shape sign up, be briefed, and participate all the same day. Finally, each of these three adventure sports is regulated by government.

The regulatory regimes among them range from a large degree of self-regulation to state-by-state decentralization, and each exhibit change over time. In 1974, the Federal Aviation

Administration (FAA) took its first step into hang gliding regulation, with suggestions for operational restrictions related to altitude, airspace, and avoiding densely populated areas. By 1982, after “near-miss reports, complaints from the general and civil aviation community, and a perceived disregard for the rules,”⁴ the FAA produced Federal Aviation Regulations (FAR), Part 103: Ultralight Vehicles, which included rules for inspections, certification, registration, and operations⁵. The sport is now in many ways self-governed and self-policed: the United States Hang Gliding and Paragliding Association is permitted by the FAA to hand out its own “licenses”, called ratings⁶. This was done with the warning that “should this approach fail to meet FAA safety guidelines, further regulatory action may be necessary.”⁷

The sky diving industry also is entrusted with a large degree of self-regulation, with the United States Parachute Association (USPA) as the key oversight agency. It describes itself as “a membership association by, for, and about skydivers—that is, people who intentionally jump from aircraft.”⁸ Sky diving regulation is guided by four primary documents: FAR Part 105 on “Parachute Operations”, FAR Part 91 on “General Operating and Flight Rules”, FAA Advisory Circular 105-2 on “Sport Parachute Jumping”, and FAA Advisory Circular 90-66 on “Recommended Standard Traffic Patterns for Aeronautical Operations at Airports Without Operating Control Towers”. The FAA retains certain direct oversight by controlling manufacturing standards, parachute riggers, and reserve parachute packing⁹. The National Transportation Safety Board also oversees aspects of the industry, such as the safety of the planes that transport skydivers¹⁰. However, USPA oversees compliance with the Basic Safety Requirements and issues skydiving licenses, which are recognized internationally by the International Parachuting Commission of the Fédération Aéronautique Internationale.

⁴ Gregor, J. (2001, September). Proposed FAA "Sport Pilot" Certification. *Hang Gliding Magazine* .

⁵ Code of Federal Regulations. (1982, October 4). *Title 14: Aeronautics and Space, Part 103 - Ultralight Vehicles*. Retrieved March 12, 2008, from Electronic Code of Federal Regulations: <http://ecfr.gpoaccess.gov/cgi/t/text/text-idx?c=ecfr&sid=b3f6202ef4d583b41ca9ed51a3d54526&rgn=div5&view=text&node=14:2.0.1.3.16&idno=14>

⁶ Trudeau, G. (2008, March 14). United States Hang Gliding and Paragliding Association Region 8 Director. (M. E. Leybovich, Interviewer)

⁷ Gregor, J. (2001, September). Proposed FAA "Sport Pilot" Certification. *Hang Gliding Magazine* .

⁸ USPA. (2003). *About USPA*. Retrieved April 3, 2008, from United States Parachute Association: <http://www.uspa.org/about/uspa.htm>

⁹ USPA. (2003). *Skydiving Regulation*. Retrieved April 3, 2008, from United States Parachute Association: <http://www.uspa.org/about/faa.htm>

¹⁰ Associated Press. (2008, September 16). *NTSB finds flaws in skydiver aircraft safety*. Retrieved October 3, 2008, from USA Today: http://www.usatoday.com/news/washington/2008-09-16-skydiving_N.htm

Throughout the early history of modern bungee jumping, there were calls for regulation. Congress passed the Consumer Product Safety Act in 1972, which created the United States Consumer Product Safety Commission (US CPSC), an independent federal regulatory agency designed to protect the public from “unreasonable risks of injury and death” from consumer products¹¹. The bungee jumping industry operated without a fatality from the sports inception in 1979 until a fatal accident in California in 1991. The California Occupational Safety and Health Administration began issuing regulations on bungee jumping on November 25, 1991. Then, on July 24, 1992, the California State Legislature passed AB 2778, formally adding bungee jumping to the list of amusement rides that were to be overseen and regulated by the state (O'Connor & Swenson, 1997). Following this, states across the nation began mandating stricter government regulation and oversight of bungee jumping companies. The result of this was that bungee jumping operators “started dropping like flies”, eventually whittling the industry down to 12-20 legitimate jump sites across the United States¹². Currently, the US CPSC has jurisdiction over traveling rides¹³ and all but five states conduct some sort of amusement ride oversight (O'Connor & Swenson, 1997). Private organizations also contribute towards design and operation standards for the industry¹⁴, including ASTM Committee F24 on Amusement Rides and Devices, Council for Amusement & Recreational Equipment Safety, National Association of Amusement Ride Safety Officials, Outdoor Amusement Business Association, and Amusement Industry Manufacturers & Suppliers International, Ltd.

In this chapter, we have explored the theoretical and historical backgrounds of government regulation, risk and safety, technological risk and disaster, and adventure sports. We will revisit and synthesize these themes in Chapter 5 after the complete background of the history and regulation of CHS that is immediately following in Chapter 3.

¹¹ US CPSC. (2007, December). Directory of State Amusement Ride Safety Officials. (V. Ceasar, Ed.) Bethesda, MD: US Consumer Product Safety Commission.

¹² Dale, C. (2008, January 17). North American Bungee Association President. (M. E. Leybovich, Interviewer)

¹³ US CPSC. (2007, December). Directory of State Amusement Ride Safety Officials. (V. Ceasar, Ed.) Bethesda, MD: US Consumer Product Safety Commission.

¹⁴ CRB. (1997, August). *Amusement Ride Laws and Regulations*. Retrieved January 31, 2008, from California Research Bureau, California State Library: <http://www.library.ca.gov/crb/97/12/97012lr.html>

CHAPTER 3: HISTORY AND REGULATION OF COMMERCIAL HUMAN SPACEFLIGHT

This thesis focuses on government regulation and oversight for protecting passenger safety in CHS. The discussion is centered on suborbital space tourism, as orbital CHS activities will not begin operation for at least the next few years. By that time, there will have been enough experience with regulation of suborbital CHS to better inform that discussion. From this point on, CHS will refer to suborbital activities unless otherwise noted.

This chapter will consider the history that has led to the current state of regulation of CHS. From there, we will begin to turn the discussion towards technical considerations and the start of policy recommendations.

3.1 Commercial aviation regulatory history

Given that the FAA is currently responsible for regulation and oversight of CHS, and that parallels exist between CHS and early aviation (Hudgins, 2002), it is useful to look at the history of the commercial airline industry and the evolution of its regulatory system. This is particularly true in the realm of safety regulation.

The first human airplane flight occurred in 1903, and by 1908 the first passenger fatality was recorded. Though the early industry was *laissez faire* (Komons, 1978), by 1912 the Aero Club of America was calling for federal registration of planes and pilot's licenses. The National Advisory Committee for Aeronautics (NACA) began pushing for regulation soon after its founding in 1915. President Woodrow Wilson submitted a bill drafted by NACA to Congress in 1919 that would have allowed the Department of Commerce (DOC) to begin regulating aircraft safety, though the bill died through inaction. In 1922 the Merchants' Association of New York joined the call for federal safety regulation of commercial aviation (Komons, 1978). The first standardizations in airplanes were implemented during World War I, and commercial aviation was first regulated in 1925 with the Kelly Airmail Act (Burkhardt, 1967; Komons, 1978).

By 1926, the nascent aviation industry was again asking for safety regulation. That year, Congress passed the Air Commerce Act, which gave the Secretary of Commerce responsibility of “fostering air commerce, issuing and enforcing air traffic rules, licensing pilots, certifying aircraft, establishing airways, and operating and maintaining aids to air navigation.”¹⁵ With this authority, the Aeronautics Branch of DOC decreed that all aircraft be federally registered, created licenses, and built landing and communications infrastructure (Burkhardt, 1967). In 1934, the Aeronautics Branch was renamed the Bureau of Air Commerce and took over air traffic control in 1936. The Civil Aeronautics Act of 1938 created an independent federal aviation agency, the Civil Aeronautics Authority, to regulate fares, routes, and safety through the Air Safety Board. In 1940, the Authority split into the Civil Aeronautics Administration (CAA) and Civil Aeronautics Board (CAB), both still in DOC (Burkhardt, 1974). The CAA oversaw air traffic control, certification, safety enforcement, and airways, while CAB was responsible for safety rulemaking, accident investigation, and economic regulation of airlines. (Bridson, Champie, & Marrison, 1974)

Not all stakeholders were pleased with expanded federal regulation. Edward Rickenbacker, an early aviation pioneer, “resented” the amount of control that the CAB imposed upon the industry¹⁶. But even as aviation regulation continued to expand as the air industry grew rapidly after World War II, the regulatory regime struggled to keep pace with the industry. By the late 1950s, there was warning of a “crisis in the making” in airspace management (Burkhardt, 1967). In June of 1958, after two midair collisions that year caused by incompatible air traffic control systems, and in part spurred by the advent of new airliner jet technology, President Dwight Eisenhower asked Congress to commission an independent federal aviation agency¹⁷.

By August of 1958, the Federal Aviation Act was passed, creating the Federal Aviation Agency (FAA), which took over most of CAB’s safety responsibilities. Administrator Pete Quesada sought to bolster of the FAA’s safety role, leading the agency to begin conducting its own safety tests and regulating safety across the industry (Whitnah, 1966). The FAA moved

¹⁵ FAA. (2005, March 5). *A Brief History of the Federal Aviation Administration*. Retrieved March 3, 2008, from Federal Aviation Administration: <http://www.faa.gov/about/history/brief%5Fhistory>

¹⁶ Rickenbacker, E. V. (1967). *Rickenbacker*. Englewood Cliffs, NJ: Prentice-Hall, Inc.

¹⁷ FAA. (2005, March 5). *A Brief History of the Federal Aviation Administration*. Retrieved March 3, 2008, from Federal Aviation Administration: <http://www.faa.gov/about/history/brief%5Fhistory>

largely intact to the new Department of Transportation in 1967, keeping its acronym but changing its name to the Federal Aviation Administration. Most of the CAB's remaining responsibilities were transferred to the National Transportation Safety Board (Briddon, Champie, & Marraine, 1974). Regulation continued to expand until the Airline Deregulation Act of 1978 essentially finished the CAB, which officially folded after 1984¹⁸.

Through a combination of technological advances, operational experience, and the FAA's focus on risk reduction, commercial aviation boasts an impressive safety record. In 2004, the commercial aviation industry as a whole operated 9,886,851 flights carrying 629,739,062 passengers resulting in 72 incidents or accidents that caused 14 deaths. This translates to a 2.2×10^{-8} fatality rate by passenger, or 2.02×10^{-7} fatality rate by flight, with vehicle failure rate of 7.28×10^{-6} (Launius & Jenkins, 2006). The chart below demonstrates flight and fatality rates, with the former steadily growing while the latter trends towards zero. These trends have made it possible for passengers to be much more confident in taking a flight, allowing the industry to mature and grow.

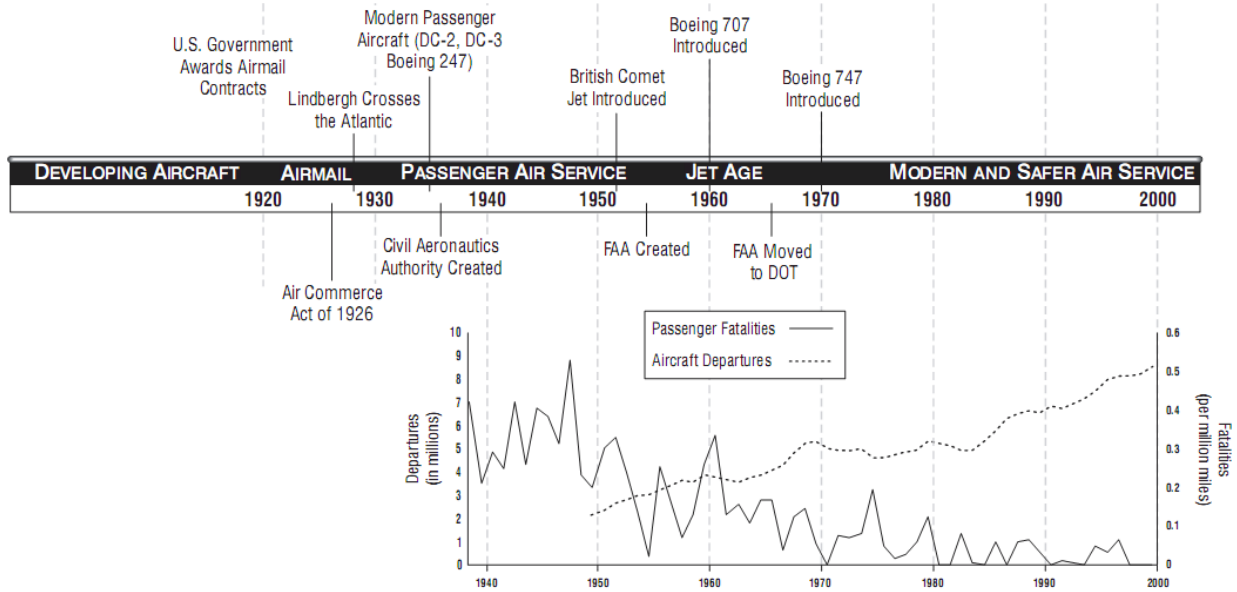

Figure 3: History of US commercial aviation from (FAA/AST, 2002a)

¹⁸ FAA. (2005, March 5). *A Brief History of the Federal Aviation Administration*. Retrieved March 3, 2008, from Federal Aviation Administration: <http://www.faa.gov/about/history/brief%5Fhistory>

Today, the FAA is involved in a range of activities, from safety regulation, to air traffic control, to research and development, to commercial space transportation. CHS is regulated in this last category, through the Office of Commercial Space Transportation (FAA/AST).

3.2 Commercial spaceflight history

Commercial interests have participated in spaceflight in one form or another since the early days of the space age. The CS industry began in the US in 1962, when NASA launched AT&T's Telstar 1 satellite (FAA/AST, 2008b) in accordance with one of its charter goals to support CS interests. The first private American space launch was conducted in 1982 by Space Services Inc, a Texas company founded by former astronaut Deke Slayton¹⁹. The CS industry has continued to grow, and now includes industry groups such as launch vehicle, satellite, and ground equipment manufacturing; direct-to-home, VSAT, and satellite data and communication services; Global Positioning System (GPS), transponder leasing, mobile satellite telephony, Earth observation and mapping, remote sensing, launching experimental payloads, high-bandwidth and broadband data services, and satellite radio. The industry overall in 2006 generated \$139 billion in economic activity, \$35 billion in earnings, and supported 729,240 jobs. This continues the trend of roughly 45-60% increase in economic growth and 15-30% increase in jobs every 3-4 years for the last 10 years (FAA/AST, 2008b).

The federal government has been very involved in CS in a number of roles since the beginning, serving as a "customer, investor, and facilitator" (FAA/AST, 2008b). Commercial payloads flown on the shuttle were even competing favorably with commercial launchers before the practice was stopped altogether after the Challenger accident in 1986 (Gress, 2002a). The federal government currently purchases launch services from the CS industry, with 13 of 15 expendable launch vehicle (ELV) launches in 2006 carrying government payloads. It supports

¹⁹ Pellerin, C. (2006, January 13). *U.S. Agency Proposes Rules for Commercial Human Space Flights*. Retrieved May 2, 2008, from GlobalSecurity: <http://www.globalsecurity.org/space/library/news/2006/space-060113-usia01.htm>

new launch vehicle development and regulates the CS industry (FAA/AST, 2008b). Also, FAA/AST together with the military share responsibility for range safety in CHS^{20,21}.

3.3 Commercial human spaceflight history to present

The newest subsector of CS is CHS. The space community has spoken of the prospect of CHS for almost as long as astronauts have been sent into space by government programs. It has only been in the past several years that CHS has begun to demonstrate its potential as a technically and commercially viable industry.

The Ansari X-Prize was instrumental in spurring technological development in the CHS industry, and can be seen as the starting point of the modern CHS era. Founded in 1996, the Ansari X-Prize offered \$10 million to the first team to privately design, build, and launch a spacecraft capable of carrying three passengers to an altitude of 100km, reenter and land it safely, and do it again using the same craft within a two-week period (Hughes & Rosenberg, 2005). It was modeled after the aviation prizes of the early 20th century, which promoted development of the modern air industry. By 1998 there were eleven reusable launch vehicle (RLV) programs in development²² and within eight years the competition drew over 20 teams from 7 countries. In 2004, Scaled Composites won the prize with their Burt Rutan-designed and Paul Allen-funded RLV SpaceShipOne. This was a major step in advancing CHS as more feasible in the near-term than ever before, and has spurred more space prize schemes such as NASA's Centennial Challenges, Google's Lunar X-Prize, and Bigelow Aerospace's America's Space Prize (FAA/AST, 2008b).

The first major application of CHS will be space tourism (Launius & Jenkins, 2006), which looks to be a real possibility in the next several years. There is much commercial potential, as well as real challenges, in this activity (Dobbs & Newquist, 2001; DFI International,

²⁰ AFSC-FAA. (2005, August 15). *Memorandum of Agreement Between Air Force Space Command and Federal Aviation Administration Office of the Associate Administrator for Commercial Space Transportation for Resolving Requests for Relief from Common Launch Safety Requirements* .

²¹ USAF-FAA. (2007, September 13). *Memorandum of Agreement Between Department of the Air Force and Federal Aviation Administration on Safety for Space Transportation and Range Activities*.

²² Edwards, J. S. (2007, January 15). RLV Hopes Ride High: Space tourism may ease path to low-cost launches, Virgin Galactic and Kistler are in forefront. *Aviation Week & Space Technology* , 166 (3), p. 152.

2002; Lambright, 2003; OECD, 2004). In a recent poll, 39% of Americans from across the wealth spectrum said that they would go into space if money were no object²³, though market data shows that willingness is highly dependent on price (Crouch, Devinney, Louviere, & Islam, 2007). There have already been five spaceflight participants (SFPs) with a sixth scheduled to launch in October 2008. Each SFP has paid at least \$20 million to the Russian space program, with the company Space Adventures acting as an intermediary, to be taken by a Soyuz spacecraft to the International Space Station for a week to ten days.

Suborbital space tourism looks to be the activity with the most near-term commercial potential. To estimate consumer demand, an independent survey was commissioned by Futron Corporation and conducted by Zogby International in 2002 (updated in 2006) that examined the market for space tourism²⁴. The survey interviewed 450 individuals who possess the means to participate in space tourism and studied demographics, affordability, interest, novelty, health, and market diffusion (Futron, 2002; Futron, 2006).

Paired with another 2002 report by DFI International, there is a fairly comprehensive set of data about how the market is expected to perform economically. Figure 4-Figure 6 share data regarding price elasticity and both demand and revenue forecasts. Plotted on logarithmic axes, the demand curve goes from about 100 passengers per year willing to pay \$100,000-\$500,000 to 10,000,000 passengers per year willing to pay \$2,000-\$6,000.

Forecasting into the future, using Fischer-Pry analysis, there may be anywhere from 8,000 to 17,000 passengers per year by 2020, depending on whether the market maturation and saturation time is 35, 40, or 45 years. These participation figures could lead to revenues of over \$650 million by 2020. These figures should be taken with a grain of salt as they assume no major disruptions to the industry through 2020, but they are useful while discussing the best-case scenario for the CHS industry.

²³ ABC News. (2008, February 8). Four in 10 Would Fly in Space; Just Knock \$198,000 Off the Ticket. New York, NY: ABC News/Good Morning America.

²⁴ Coppinger, R. (2008, March 25). *Sales are rocketing at Virgin Galactic*. Retrieved March 26, 2008, from FlightGlobal: <http://www.flightglobal.com/articles/2008/03/25/222290/sales-are-rocketing-at-virgin-galactic.html>

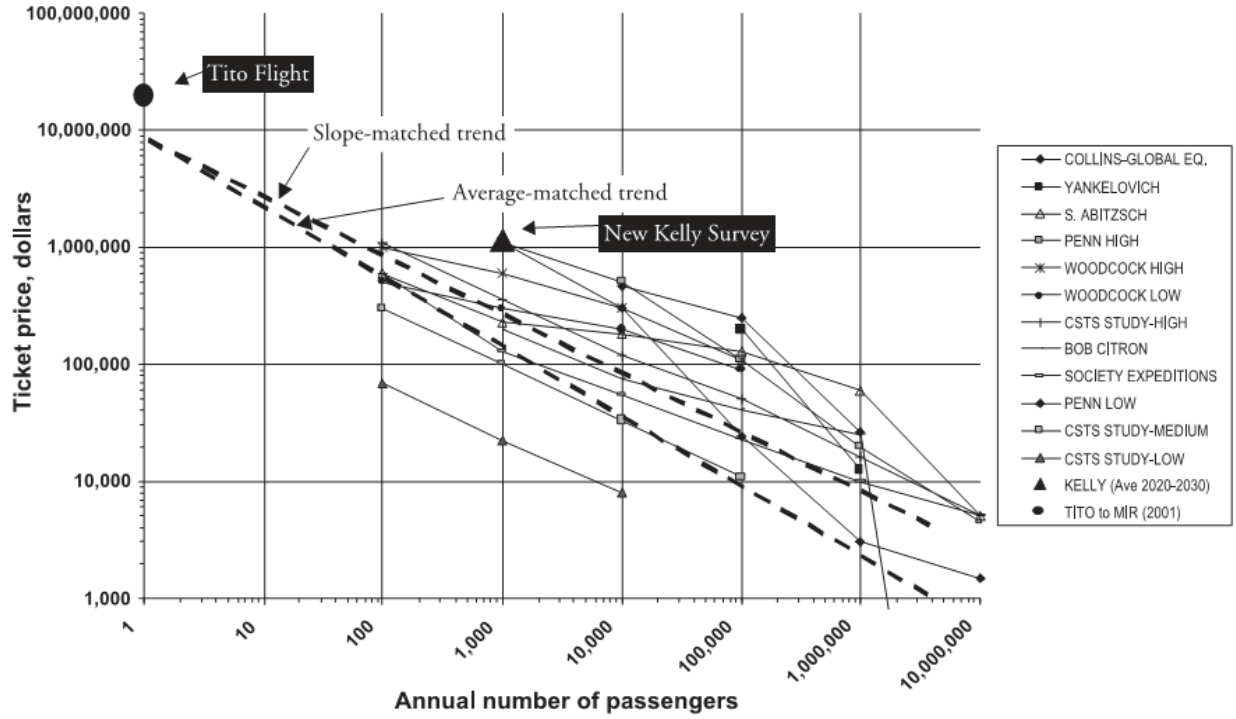

Figure 4: Price elasticity: a market research comparison from (DFI International, 2002)

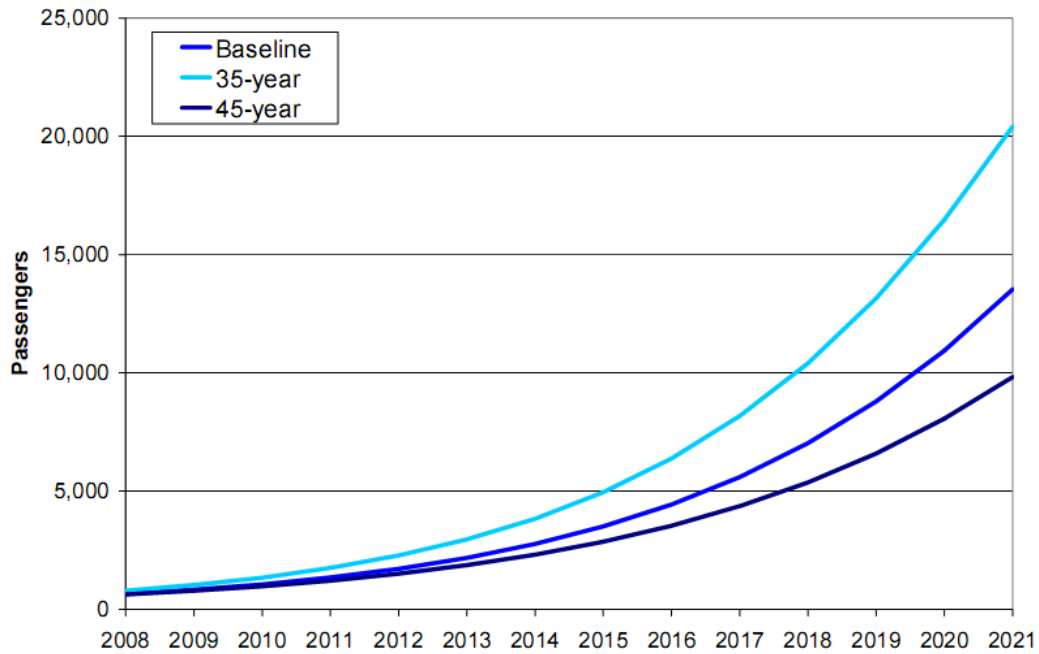

Figure 5: Passenger demand forecast with different market maturation periods from (Futron, 2006)

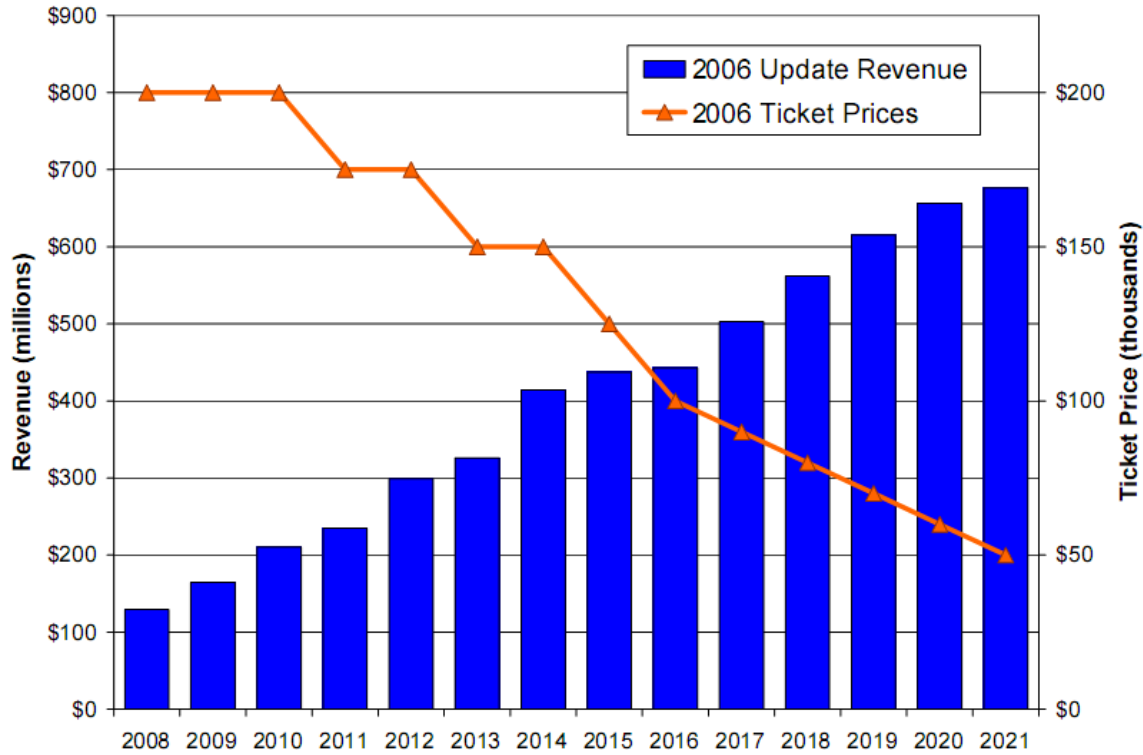

Figure 6: Revenue forecast for suborbital space tourism from (Futron, 2006; Starzyk, 2006)

After SpaceShipOne won the X-Prize, Richard Branson of the Virgin Group announced that he would invest in a new company called Virgin Galactic to offer suborbital space tourism trips at approximately \$200,000 per passenger (Hughes & Rosenberg, 2005). Over 250 customers have already booked a seat through approximately 90 agents worldwide, with Virgin Galactic having already collected \$35 million²⁵. The CHS industry as a whole has reported \$268 million in industry revenue for 2007, \$1.2 billion in cumulative investment, and 1,227 workers supported, though these numbers include many things beyond actual CHS hardware and sales²⁶.

The CHS industry still faces challenges from wary investors unsure if and when they will see a return (Launius, 2003), but through a combination of privatization and commercialization (Pace, 2003), the industry should soon be in a position to require more government oversight.

²⁵ Coppinger, R. (2008, March 25). *Sales are rocketing at Virgin Galactic*. Retrieved March 26, 2008, from FlightGlobal: <http://www.flightglobal.com/articles/2008/03/25/222290/sales-are-rocketing-at-virgin-galactic.html>

²⁶ PSF. (2008, May 28). *Personal Spaceflight Federation to release results of new study defining personal spaceflight industry: First-time study reveals significant investment and revenue growth*. Retrieved May 29, 2008, from Personal Spaceflight Federation: <http://www.personalspaceflight.org/pressreleases.htm>

3.4 Commercial human spaceflight regulatory history

The foundation for American government regulation of CS is that the US is responsible by international treaty for damages to the territory, property, and/or citizens of other nations caused by space activities of its agents and citizens, whether government-sponsored or not (Hermida, 2004). The principal governing treaties are the 1967 “Treaty on Principles Governing the Activities of States in the Exploration and Use of Outer Space, Including the Moon and Other Celestial Bodies” – also known as the “Outer Space Treaty” (Gerhard, 2005) – and the 1972 “Convention on International Liability for Damage Caused by Space Objects”, also known as the “Liability Convention” (Kerrest, 2005). Since these early treaties, international space law has gone from highly international conventions over broad principles to specific legal regimes (Benkö & Schrogl, 2005). There is no current international organization that regulates CS safety activities (IAASS, 2007), though the US has played a leadership role.

There was no single regulatory agency responsible for CS when the industry first began. Early CS companies had to speak with a wide range of governmental agencies to piece together a regulatory stamp of approval. In 1984, the Commercial Space Launch Act (CSLA) was passed directly after Executive Order 12465, giving charge of this industry to the Department of Transportation (DOT) (US Congress, 1984) after NASA expressed no interest in this regulatory role (Gress, 2002a). The legislation included a requirement that private American citizens obtain a license before launching a vehicle into space²⁷. By 1988 (US Congress, 1988b), DOT had established procedures to obtain a commercial space launch license, and asserted that it would be responsible for non-governmental launches, whether crewed or uncrewed.

In 1995, regulatory authority was delegated to the FAA within DOT²⁸. In 1998 the CSLA was amended by the Commercial Space Act (US Congress, 1998) to regulate noncrewed RLVs as well (Macauley, 2005), and the FAA began issuing reentry licenses. In 2000, FAA/AST crafted as complete a regulatory and licensing framework for RLVs as was both

²⁷ Nield, G. C. (2005, April 5). Commercial Space Flight -- New Legislation and the Industry and Developments which Impact Commercial Airports. *FAA NW Mountain Region Airports Conference*. Federal Aviation Administration.

²⁸ Antuñano, M. (2007, October 31). “Regulatory Medical and Safety Aspects of Space Tourism”. MIT Space, Policy, and Society research group. Cambridge, MA, USA: Federal Aviation Administration.

technologically feasible and congressionally permitted. These rules were meant to primarily protect public safety from errant launches and reentries. Companies were required to predict and plan for hazards, largely steer clear of populated areas, and demonstrate that their RLV was no more dangerous than would be an analogous ELV flight. A company could receive either a mission-specific or general operator license, and in 2004 Scaled Composites won the X-Prize with an FAA-issued RLV license (Hughes & Rosenberg, 2005).

The first legislation focused on CHS came in 2004 with the passage of the Commercial Space Launch Amendments Act (CSLAA) (US Congress, 2004). This legislation, amending Title 49 of the US Code, Subtitle IX, Chapter 701, had a rocky history, illustrating conflicts between different approaches to regulation. The CSLAA evolved from H.R. 3245 and H.R. 3752. The former, known as the “Commercial Space Act of 2003” (US Congress, 2003) was heard before the House Science Committee, which discarded it in favor of the more comprehensive latter. That bill passed almost unanimously through the House of Representatives, but ran into initial trouble in the Senate. After Senate edits, the bill was resubmitted in the House as H.R. 5382, the CSLAA.

The debate was more vigorous the second time around. Proponents likened space tourism to adventure travel more than to tradition aviation, and did not wish to impede industry experimentation. Opponents felt that informed consent to protect SFPs was not strong enough and that waiting for a fatality before beginning the next steps in regulation was both morbid and unsafe. This central tension between “stifling innovation” and “tombstone mentality” resulted in contentious debated. It passed the House but looked headed towards failure in the Senate before passing as one of last bills of the 108th Congress. Unsatisfied with the result, Representative James Oberstar introduced H.R. 656 – “To amend title 49, United States Code, to enhance the safety of the commercial human space flight industry” – in the 109th Congress, though it gained no traction (Hughes & Rosenberg, 2005).

The CSLAA allowed the FAA to create training and medical standards for passengers and crew like the training currently offered at the National AeroSpace Training and Research Center (NASTAR Center) in Southampton, PA (FAA/AST, 2008a). However, the bill did not

permit further protection of passenger and crew safety immediately. By the terms of the legislation, they are limited to “restricting or prohibiting design features or operating practices” that “have resulted in a serious or fatal injury ... to crew or space flight participants during a licensed or permitted commercial human space flight” or “contributed to an unplanned event or series of events during a licensed or permitted commercial human space flight that posed a high risk of causing a serious or fatal injury ... to crew or space flight participants” until at least 2012. In other words, FAA/AST cannot regulate design or operations until 2012 unless there a flight causes serious²⁹ or fatal³⁰ injury to passengers or crew before that time.

The choice of 2012 as a design and operations regulation starting point was a compromise between the majority Republican committee staff who sought 2016 and the minority Democratic committee staff who supported an immediate start in 2004. The majority staff philosophically supported a permanent ban, but settled for what they felt would be enough time to allow innovation and best-practices designs and operations to evolve. The 2012 compromise was admittedly “somewhat arbitrary”, but was the most widely accepted amongst a number of timelines and metrics discussed.³¹

Whether or not the 2012 date is *still* appropriate is a legitimate question. At the time of the 2004 legislation, it appeared as though CHS companies may be operational by 2006. However, as of 2008, 2010 looks like a more realistic date. This has prompted concern within the CHS industry, as voiced by the Personal Spaceflight Federation, that 2012 may not still be best design and operations regulatory start date. Further, there is discussion about whether using a date rather than a given metric (i.e. number of cumulative flights or passengers) is optimal for both protecting participant safety and promoting industry growth.

²⁹ “Serious injury” is any injury which: (1) Requires hospitalization for more than 48 hours, commencing within 7 days from the date of the injury was received; (2) results in a fracture of any bone (except simple fractures of fingers, toes, or nose); (3) causes severe hemorrhages, nerve, muscle, or tendon damage; (4) involves any internal organ; or (5) involves second- or third-degree burns, or any burns affecting more than 5 percent of the body surface (United States, 2007).

³⁰ “Fatal injury” is any injury which results in death within 30 days of the accident (United States, 2007)

³¹ Hughes, T. R. (2008, May 8). Vice President & Chief Counsel, Space Exploration Technologies. (M. E. Leybovich, Interviewer)

As now stands, FAA/AST can only regulate design and operations to protect the public, which may involve some regulation that will also protect passengers and crew as a result. The SFP safety protection mechanism codified by the CSLAA is informed consent (Cloppenburg, 2005; Knutson, 2007; Walker, 2007). Potential SFPs must be warned in writing that the vehicle is not government-certified as safe, and that accident victims are not covered under government indemnification. Commercial operators must also disclose all pertinent safety information (without overwhelming SFPs with information as to bury the most relevant details) and the SFP waives liability claims against the federal government (FAA/AST, 2006b). Not all stakeholders are pleased with this approach, with spacecraft designer Burt Rutan calling for more focus on the passengers by regulating suborbital spacecraft more like airplanes than like launch vehicles³². Other commentators liken this regulatory approach to passengers offering themselves up as “experiments” (Walker, 2007).

As for other features of the CSLAA, “suborbital rocket” was defined as a vehicle that uses rocket propulsion in whole or part to embark on a suborbital trajectory and whose ascent employs thrust greater than its lift. Also, the Secretary of Transportation was given freedom to determine which office will provide regulation and licensing (though not certification like airplanes receive^{33,34}), under the condition that only one license be required (Hughes & Rosenberg, 2005). The launch licensing process includes reviews of safety, environmental impact, payload, policy, and financial responsibility (GAO, 2006).

FAA/AST currently has a dual regulatory/promotional relationship with the CS industry, with a Congressional mandate to “encourage, facilitate, and promote commercial space launches and re-entries” (Pelton, 2007). This role is shared with the DOC³⁵, which was made responsible for advocating for the CS industry through the Office of Space Commercialization (OSC) (US Congress, 1988a) by the Technology Administration Act of 1988. However, the OSC has been

³² Foust, J. (2006, May 8). *The space industry's curmudgeon*. Retrieved March 13, 2008, from The Space Review: <http://www.thespacereview.com/article/618/1>

³³ Foust, J. (2003, April 28). *RLV regulation: licensing vs. certification*. Retrieved May 6, 2008, from The Space Review: <http://www.thespacereview.com/article/18/1>

³⁴ Antuñano, M. (2007, October 31). “Regulatory Medical and Safety Aspects of Space Tourism”. MIT Space, Policy, and Society research group. Cambridge, MA, USA: Federal Aviation Administration.

³⁵ FAA/AST & DOC-OSC. (2007, September 19). Memorandum of Understanding Between Office of Commercial Space Transportation and Office of Space Commercialization. Washington, DC.

inconsistent in its functionality, lacking even a director from 2002-2006 and has not played as large a role as FAA/AST in CS promotion³⁶. Whether or not FAA/AST's promotion responsibilities will continue is unclear. Several other government agencies that once both regulated and promoted eventually relinquished the promotional function, such as the United States Federal Maritime Board in 1961, the Atomic Energy Commission in 1975, and the FAA in 1996 in the aftermath of the ValuJet accident.

A recent report by the Government Accountability Office (GAO) found that FAA/AST has been doing a good job of assuring safety through well-defined processes, while minimizing compliance costs for companies. The study points to the fact that none of the nearly 200 FAA-licensed/primarily Department of Defense (DOD)-operated launches to date have resulted in serious accident, injury, or damage. The report does suggest, however, that the FAA should identify the specific "high risk" circumstances that would trigger a stricter design and operation regulatory regime (GAO, 2006).

The story of the FAA's evolution is similar to the story of the emerging government regulatory regime for CHS by FAA/AST. Both regulatory institutions have had to balance between promoting and regulating a nascent, high-tech industry. The progress of CS and CHS make now the right time to make decisions about near-future regulation of passenger safety in CHS. The next section, Chapter 4, provides a technical analysis of critical subsystems, mission phases, and HS incidents and accidents to date. Combined with the theory of Chapter 2 and CHS background of Chapter 3, the technical discussion will allow us to make conclusion and recommendations in Chapter 5.

³⁶ Bitterman, M. (2008, April 16). A Commercial Space Industry Perspective on U.S. Space Policy: The Good, The Bad, and The Ugly. *Space, Policy, and Society Seminar Series*. Cambridge, MA.

CHAPTER 4: RISK AND SAFETY IN COMMERCIAL HUMAN SPACEFLIGHT

This technical analysis will discuss the CHS industry, its operating environment and vehicles, past and current suborbital HS efforts, critical mission phases and subsystems, risk in HS, and historical incident and accident data. We will find that critical nodes exist in the many combinations of mission phases, subsystems, and CHS mission modes. These will be the targets for regulation that we will discuss in the conclusions and recommendations in Chapter 5.

4.1 Definitions

Part of regulating CHS is knowing where space “begins”. At as little as 16 km altitude a pressure suit becomes necessary, and a rocket engine at 45 km. The DOD will grant astronaut wings when an individual has reached 81 km (Goehlich, 2002). Other altitudes for space range from 96km (Andrews, 2001) to 110 km (Kayser, 2001). The most internationally-recognized boundary of space is the Kármán line at 100 km (62.1 miles), which is the definition accepted by the Fédération Aéronautique Internationale (IAASS, 2007). 100km was also the boundary for the X-Prize and what most suborbital space tourism operators are striving to reach.

This thesis is considering only suborbital CHS. The difference between suborbital and orbital is an order of magnitude more energy required. A suborbital spaceflight trajectory requires a velocity of between 1-1.5 km/s, while a spacecraft must reach 7.9 km/s to attain orbit (International Space University, 2000). A suborbital spaceflight would provide about 3-5 minutes in microgravity, while one orbit takes over an hour (Goehlich, 2004). Because of the considerable differences between these two types of space trajectories, most CHS companies are pursuing suborbital commercial offerings before orbital options.

CHS vehicles will operate both in the lower atmosphere and in space. To define how a vehicle is classified, the International Civil Aviation Organization Convention gives the following definitions:

Table 2: Air and space vehicle definitions
based on (IAASS, 2007)

Term	Definition
Aircraft	Any machine that can derive support in the atmosphere from the reactions of the air.
Aeroplane	A power-driven heavier-than-air aircraft, deriving its lift in flight chiefly from aerodynamic reactions on surfaces which remain fixed under given conditions of flight.
Spacecraft	A man-made vehicle which is intended to go beyond the major portion of the Earth's atmosphere.
Rocket	A vehicle or device propelled by one or more rocket engines, especially such a vehicle designed to travel through space.



The distinction between vehicle types is important, for if a CHS vehicle was to be considered an aircraft when operating within the atmosphere, it would be subject to additional regulatory categories by the Chicago Convention. These include registration, airworthiness certification, pilot licensing, and operational requirements (IAASS, 2007).

Some in CHS would prefer that suborbital CHS vehicles be considered aircraft. Burt Rutan has stated that, from a regulatory standpoint, he would rather deal with FAA's Aviation Safety Office than FAA/AST because the latter focuses "primarily with the consequences of failure, where the aircraft regulatory process deals with reducing the probability of failure."³⁷ There is precedent for hybrid regulatory schemes for vehicles that operate in multiple medium, such as military DUKW amphibious vehicles. These are regulated sometimes as more boat than automobile, and vice versa, but usually are subject to aspects of both regulatory regimes (Walker, 2007).

³⁷ Foust, J. (2005, April 25). *Two scenarios and two concerns for personal spaceflight*. Retrieved March 13, 2008, from The Space Review: <http://www.thespacereview.com/article/362/1>

There are a variety of approaches possible to space vehicle body design. Each vehicle shape poses tradeoffs in maneuverability upon reentry (in terms of lift and drag) and volumetric efficiency. Six potential shapes are considered here:

Table 3: Vehicle body types and tradeoffs
based on (Petro, 1992; Petro, 2000)

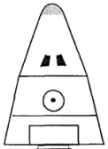
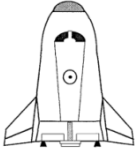
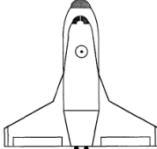
Shape	Body type	Maneuverability	Volumetric efficiency
	Spherical	Nonexistent	Moderate
	Heatshield with afterbody	Slight	Good
	Blunt cone	Slight	Good
	Biconic	Moderate	Excellent
	Lifting body	High	Moderate
	Winged body	High	Good

Most of the suborbital vehicles that we will consider here are winged bodies. The combination of control, reusability, and enough internal volume to allow SFPs the freedom to move in microgravity makes the shape a popular choice.

4.2 Space system design

Beyond body type, boundaries on design options are imposed by technical complexity (driven by schedule and design cost), safety for humans and other payload, and economic sustainability determined in part by operational costs. Four of the most important design categories are listed in Table 4, with each category's design options:

Table 4: Design tradeoffs for suborbital space vehicles based on (Goehlich, 2004)

Design feature	Choice
Take-off	Vertical or horizontal?
Stages	One or more?
Landing	Vertical or horizontal?
Reusability	Partial or full?

Take-off and landing acronyms
 HTHL = Horizontal Takeoff, Horizontal Landing
 VTVL = Vertical Takeoff, Vertical Landing
 VTHL = Vertical Takeoff, Horizontal Landing

A handful of companies have continued CHS development after the X-Prize (FAA/AST, 2005e), and each has made a unique set of choices in the design of their vehicles. This thesis will examine only a few of these companies, the ones that have the most publicly available information and that are far enough along in development that they stand a reasonable chance of being commercially operational within the next several years. A few CHS companies and proposed vehicles will *not* be considered here because of:

- Insufficient public information: Excalibur Almaz’s TKS spacecraft derivative and Space Adventures’ proposed Explorer spacecraft to be designed by Russia’s Myasishchev Design Bureau.
- Space tourism as a secondary objective: SpaceX’s Falcon-family launch vehicle and Dragon spacecraft, and Orbital Science’s Cygnus launched on their Taurus II, both participants in NASA’s Commercial Orbital Transportation Services program.
- Orbital destinations: Bigelow Aerospace is designing, testing, and constructing their Genesis-family, Sundancer, and BA 330 habitation modules as orbital space tourism destinations, but do not have a suborbital program.

Out of the above design tradeoffs, a few dominant mission modes have emerged. These are listed in Table 5, with the CHS companies which we will be discussing.

Table 5: Suborbital CHS company systems based on (FAA/AST, 2005e; Pelton, 2007)

<u>Vehicle company</u> <u>(/Operator)</u>	<u>Launch/</u> <u>Land mode</u>	<u>Launch vehicle</u>	<u>Spacecraft</u>	<u>Rocket Propulsion</u>
Scaled Composites/ Virgin Galactic	HTHL	WhiteKnightTwo	SpaceShipTwo	Neoprene (synthetic rubber)/N ₂ O
XCOR	HTHL	Lynx		Isopropyl alcohol/ Liquid oxygen
Rocketplane Global	HTHL	Rocketplane XP		Liquid
Armadillo Aerospace	VTVL	Pixel and Texel cluster derivative		Liquid oxygen/ ethanol
Blue Origin	VTVL	New Shepard		Hydrogen peroxide/ Kerosene
SpaceDev/Benson Space	VTHL	Atlas V	Dream Chaser	Neoprene/N ₂ O

Each of these mission modes balances operational benefits with unique technical challenges. HTHL and VTVL are thus far the most popular launch/landing mission modes. While VTHL is used by the Space Shuttle, VTVL was used for every prior NASA crewed mission prior and is still in use by Soyuz. HTHL was used by the only successful example to date of CHS, and has a rich testing pedigree.

4.2.2 Spaceplanes

The HTHL mission mode, specifically with a carrier aircraft employed to bring the spacecraft to a high starting altitude for space launch, was investigated in great depth with the North American Aviation X-15 research “spaceplane”. The X-15 flew under NASA and Air Force supervision as part of a government research program, and had a different purpose than today’s CHS companies. However, with a similar flight profile, and a number of related technical challenges, the X-15 is useful to consider from a design and operational perspective.

There has been a long history of US experimental aircraft, some of which sought to push the envelope on altitude and/or speed. The X-15 is regarded as one of the most successful of the approximately 50 experimental planes to date (Jenkins, Landis, & Miller, 2003). In 1952, the NACA Committee on Aerodynamics recommended pursuing a hypersonic (over Mach 5), ultra high altitude aircraft as a first step into human spaceflight (Dick, Garber, & Engel, 2000). The build-to-fly process was a collaboration, where contract winner North American Aviation would prove airworthiness up to Mach 2, then give the plane to the Air Force, who would then give to NASA (Jenkins, 2000). A prototype was built by the end of 1958, followed by flight tests in 1959 and the first piloted test in 1960 (Stillwell, 1965).

There were two types of missions flown: one to set records in altitude and one to set records for speed by winged aircraft. Figure 7 shows the trajectories and dynamic pressures involved for each type of mission:

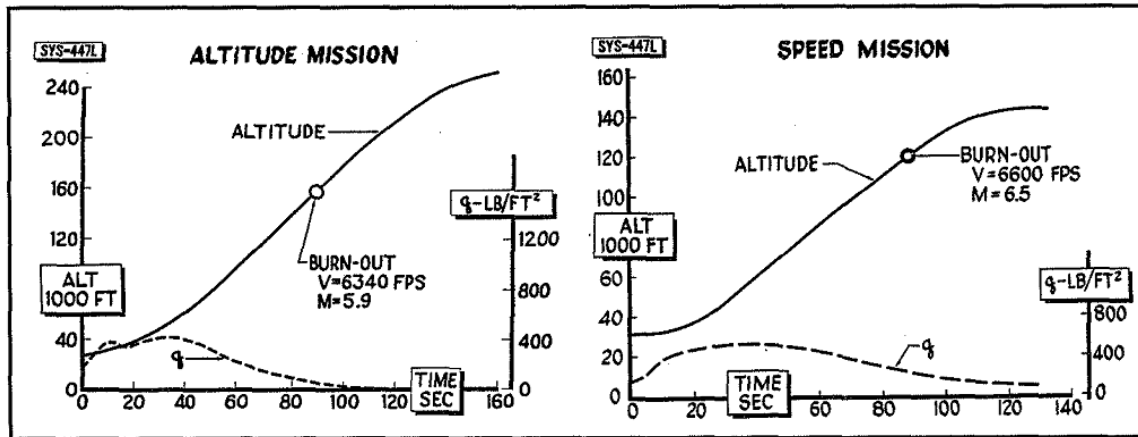

Figure 7: Types of X-15 research flights from (Jenkins, 2000)

The original goal of the program was to reach a speed of Mach 6 and an altitude of 250,000 feet. The program well exceeded both, ultimately achieving Mach 6.7 and 354,200 feet. In total, 109 of the 199 flights of the program went hypersonic (Becker, 1968) and two of the flights in 1963 exceeded the Kármán 100km altitude line. Other technical milestones were also met, including withstanding 1,350 degrees Fahrenheit of dynamic heating and 2,200 pounds of dynamic pressure per square foot.

This was all done at a high price: the final cost summed to over 30 times the original estimate, one of the planes was severely damaged, and another was destroyed, taking with it the life of test pilot Michael J. Adams (Jenkins, 2000). There were several subsystems that proved problematic, including auxiliary power units (APU), rocket engines, and stability systems (Becker, 1968). The APUs suffered from problems such as valve malfunction, leaks, and difficulty of speed control. The XLR99 rocket engines represented a huge achievement as the first large, man-rated, throttleable, restartable liquid propellant rocket engine³⁸, but had start-up problems and needed to be overhauled after one hour of use.

The thermal issues were among the most daunting. There is considerable thermal load above Mach 6, with X-15 heating in general recorded at 30-40% greater than predicted by theory and flight tests (Jenkins, 2000). The structural design itself was based around mitigating

³⁸ USAF. (n.d.). *Reaction Motors XLR99*. Retrieved April 25, 2008, from National Museum of the USAF: <http://www.nationalmuseum.af.mil/factsheets/factsheet.asp?id=890>

aerodynamic heating (Price, 1968). A spray-on ablating surface was employed to protect the craft, but it was not considered fully successful due to its performance deficiencies and the large amount of maintenance service required on and around the protected surfaces (Jenkins, 2000).

The program was eventually overtaken in the public imagination by Project Mercury. By 1964 there were proposals to end the program, justified by feelings that it was nearing the end of its useful research life. The program finally closed by the end of 1968 due to NASA's other priorities. The X-20, known as Dyna-Soar, was to be a follow-on spaceplane capable of achieving orbit, but was cancelled before the first vehicle was built (Jenkins, Landis, & Miller, 2003). The X-15's speed and altitude records stood until the space shuttle broke them for winged craft and SpaceShipOne (SS1) beat the altitude record for a suborbital spaceplane.

Several of the leading suborbital CHS designs can be seen as legacies of the X-15. The two-stage, HTHL design was used by SS1 to win the X-Prize. In both systems, a subsonic, jet-powered Stage 1 aircraft brings a Stage 2 rocket-powered spacecraft to a space launch altitude, 15 km in the case of SS1³⁹. There are also significant differences between the two programs. The X-15 reentered with a steeper angle of attack to conduct high-speed research, while SS1 utilized feathered reentry and a near vertical trajectory^{40,41}. The gentler reentry of SS1 even made it possible for the vehicle to eschew an autostabilization system. Both vehicles featured ablative thermal protection, but it was a much lighter "trowel-on" ablative surface for SS1. The high drag-to-weight ratio of SS1 resulted in a more moderate level of peak heating, with a thermal protection system (TPS) necessary for only a few hot spots on the mostly graphite-epoxy composite structure.

Virgin Galactic intends to follow the same mission mode with SpaceShipTwo (SS2). For purposes of comparison, the following pages illustrate nominal trajectories of the X-15 and SS2, as well as are design schematics.

³⁹ Sweetman, B. (2004, January). *SpaceShipOne: Riding a WhiteKnight to Space*. Retrieved May 19, 2008, from AIAA: <http://www.aiaa.org/aerospace/Article.cfm?issuetocid=446&ArchiveIssueID=46>

⁴⁰ Dornheim, M. A. (2004, October 10). *SpaceShipOne Wins Ansari X Prize*. Retrieved May 5, 2008, from Aviation Week: http://www.aviationweek.com/aw/generic/story_generic.jsp?channel=awst&id=news/10114top.xml

⁴¹ Economist. (2008, January 24). *Starship enterprise: the next generation*. Retrieved May 19, 2008, from Economist: http://www.economist.com/science/displaystory.cfm?story_id=10566293

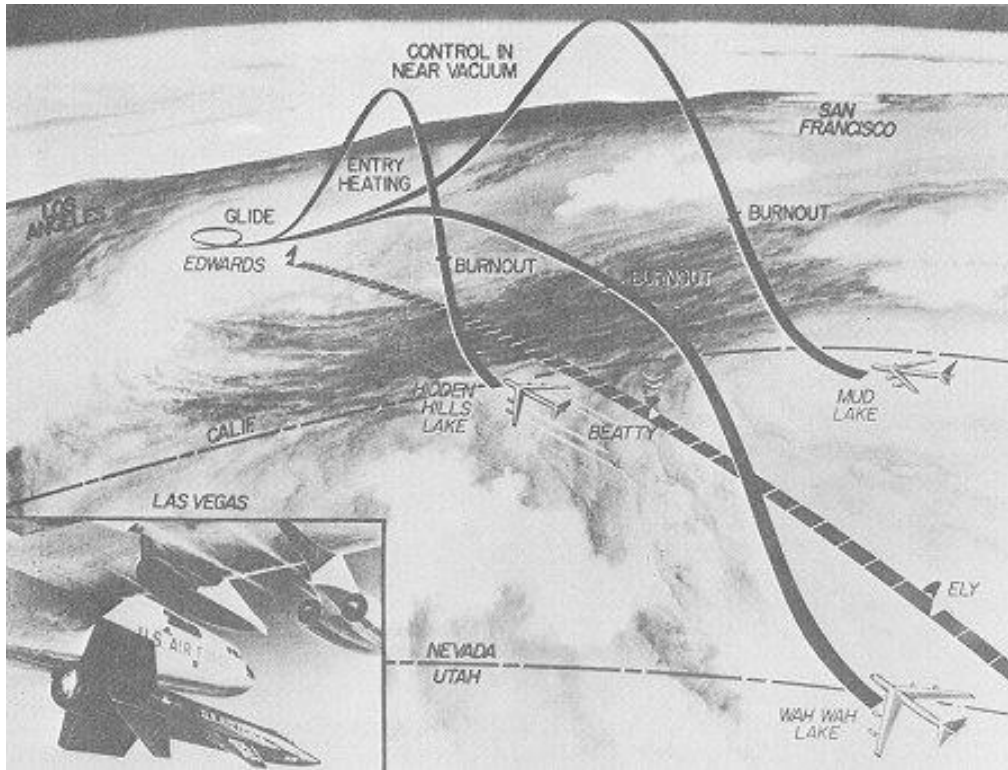

Figure 8: X-15 flight paths in California from (Becker, 1968)

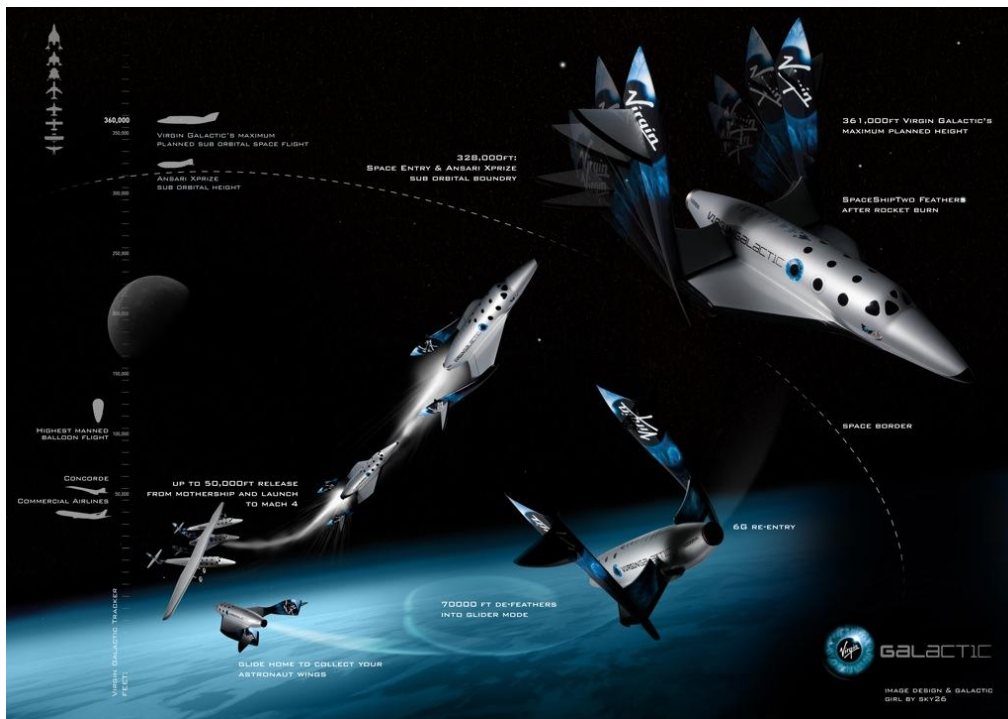

Figure 9: SpaceShipTwo flight profile from (Cain, 2008)

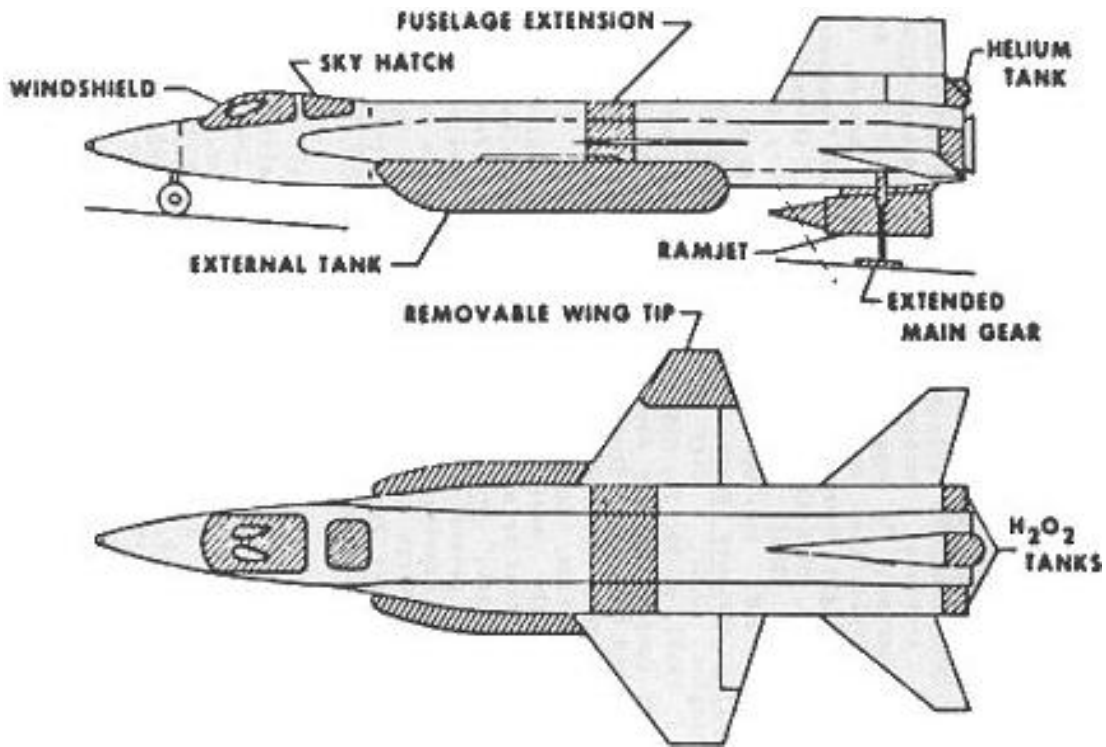

Figure 10: Modified X-15A-2 labeled schematic from (Houston, Hallion, & Boston, 1998)

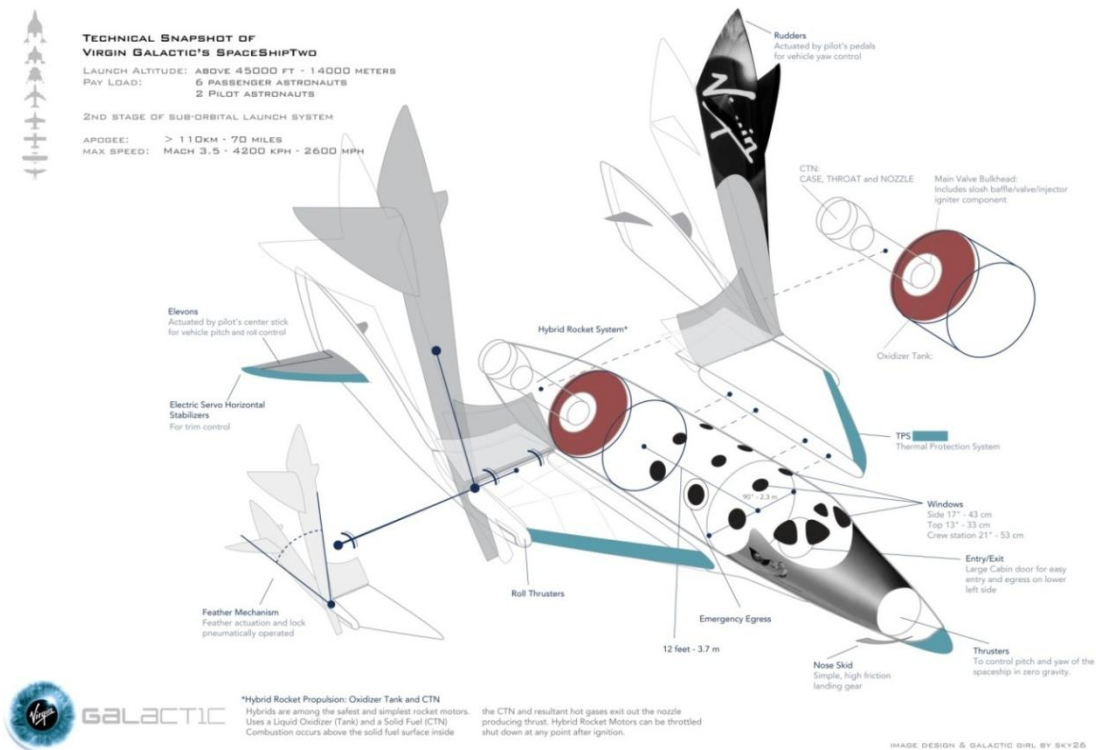

Figure 11: Technical snapshot of Virgin Galactic's SpaceShipTwo from (gizmag, 2008)

4.3 Space system operation

As is evident from the record of the X-15 research program, risk is inherent in suborbital spaceflight. Space hazards include loss of vehicle control, uncontrolled debris, uncontrolled release of hazardous materials, vehicle breakup, unsafe landing, explosion, fire, and countless other things that can go wrong (FAA/AST, 1995b; AIAA, 2005). This section will examine what can go wrong, when it can go wrong, and the relative criticality of subsystem failures.

4.3.1 Mission phases and hazards

A suborbital space mission may be divided into several sequential phases⁴²: Prelaunch, Launch (which can be separated into Ground launch and Space launch phases for some two-vehicle systems such as WhiteKnightTwo/SpaceShipTwo), Ballistic coast/Spaceflight, Reentry, Landing, and Postlanding (FAA/AST, 1995b). There are hazards associated with each segment of the mission (Heydorn & Railsback, 2000). Table 6 lists the major hazards that correspond with each mission phase, and Figure 12 illustrates them graphically.

Table 6: Mission phase definitions and physical stresses: chronological

Mission phase	Duration	Hazards
Prelaunch	The time from initial passenger and crew interface with the system (boarding) all the way up to liftoff of the system from the ground.	Premature launch System failure
Launch	The time after liftoff (ground launch) that includes the rocket burn that provides the speed for a suborbital space trajectory (space launch).	Vibration Acceleration Structural overload
Ballistic coast/ Spaceflight	The time after the rockets cut out, while the spacecraft ascends into space and the passengers can experience microgravity as the vehicle crests the trajectory.	Pressure differential Thermal shock
Reentry	The period when the spacecraft begins to experience resistance and friction from the Earth's atmosphere as it slows down and begins to descend.	Vibration Deceleration Structural overload
Landing	The time when the spacecraft descends, approaches the landing target, and comes to a halt on the Earth's surface.	Mechanical shock
Postlanding	The time from when the vehicle stops moving to recovery of the passengers and crew.	Exposure to hazardous materials

⁴² Hofstetter, W. (2008, May 15). PhD candidate. (M. E. Leybovich, Interviewer)

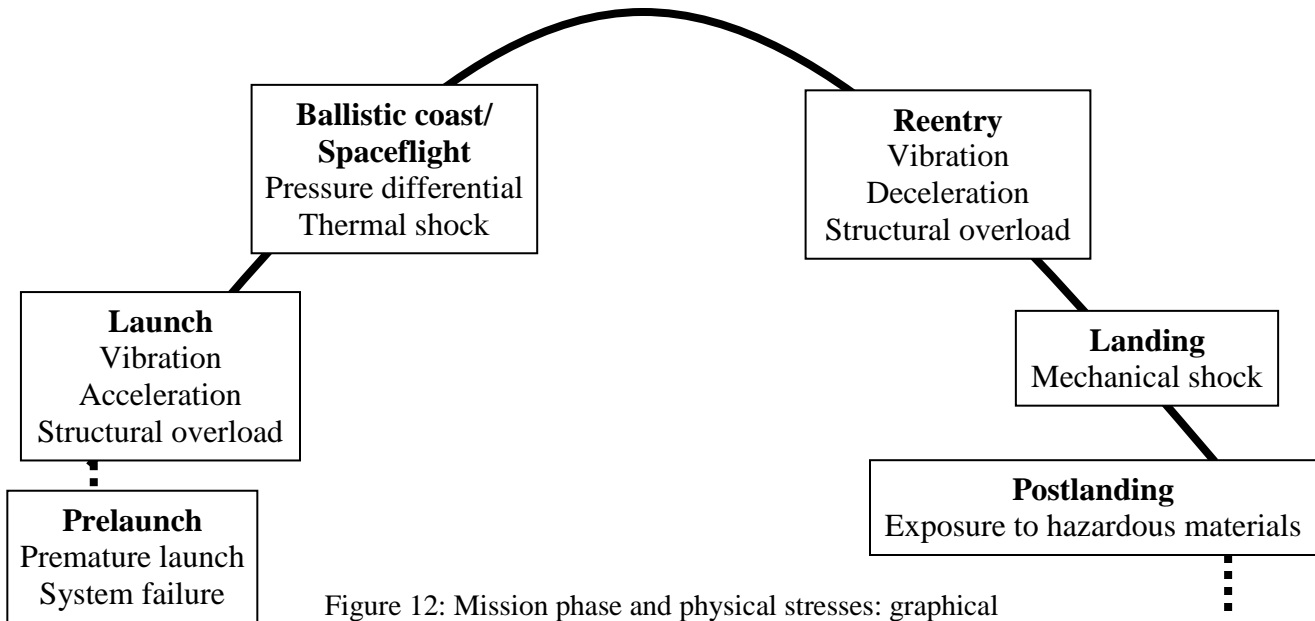

Figure 12: Mission phase and physical stresses: graphical

4.3.2 Subsystems

Major subsystems for a suborbital spacecraft are described in an overview below. While the design and operation of each subsystem from vehicle to vehicle may vary, the guiding principles, responsibilities, and design challenges for each subsystem remain the same (Riley & Sailor, 1962; Griffin & French, 1991; Pisacane & Moore, 1994; Wertz & Larson, 1999; Meyer, 1999; Larson & Pranke, 2000; Fortescue, Stark, & Swinerd, 2003).

Launch and Propulsion

(Griffin & French, 1991; Humble, 2000a; Humble, 2000b; Turner M. J., 2005)

This subsystem is the one responsible for getting the spacecraft off the ground and into space. It includes the engines, propellant, propellant tanks, and dumping systems. Design factors include payload mass, mission lifetime, spacecraft dimensions, environmental impacts and limitations, reliability and safety, and funding and political constraints. Designing a launch and propulsion system involves setting requirements, sizing the vehicle to be launched, sizing the thrust-generation and propellant-handling systems, and selecting a propulsion technology.

Currently available commercial options are primarily limited to chemical propulsion, with choices between the following types of fuel (with corresponding specific impulse data):

Table 7: Specific Impulses of chemical propulsion

Type	Specific impulse (I_{sp}) in seconds
Liquid monopropellant	140-235
Liquid bipropellant	320-460
Solid	260-300
Hybrid	290-350

Solid rockets are more reliable and have a higher propellant density, but liquid fuel rockets can get higher impulse and have better thrust control and throttleability. Designing for safety means avoiding single-point critical failures and any combination of two failures leading to catastrophic failure, as well as providing the delta-v required to achieve the propulsion goal. Possible failure modes include premature launch, failing to start or stop on takeoff, thrust anomalies, explosion, and failure to restart or stop on command when landing

Attitude Determination and Control System (ADCS)/Guidance, Navigation, and Control (GNC) (NASA, 1969; Hughes P. C., 1986; LaBel & Gates, 1996; Noton, 1998; Wie, 1998; Wertz & Larson, 1999; Glaese, Eterno, Zermuehlen, & Zimbelman, 2000)

ADCS and GNC are responsible for tracking the orientation of the spacecraft, and keeping it oriented and under control throughout its flight. ADCS keeps the spacecraft positioned about its center of mass, while GNC keeps the spacecraft as a whole positioned in relation to the environment. These subsystems include inertial measurement units (IMUs), sun sensors, star sensors, horizon sensors, and magnetometers. Utilized methods to maintain control include gravity gradient, momentum bias wheel, passive magnetic, spin stabilization, thrusters, and momentum exchange.

The design of ADCS and GNS begins with defining and selecting spacecraft attitude control modes, followed by quantifying the disturbance environment, selecting and sizing hardware, and defining algorithms for determination and control. The systems must be able to determine and control accuracy, range, jitter, drift, and settling time, while avoiding gimbal lock.

Possible failure modes include premature or delayed operation, inadvertent operation, drift/shift, axis alignment or bias anomaly, and failure to stop. Following is an example of a GNC system, from the X-15.

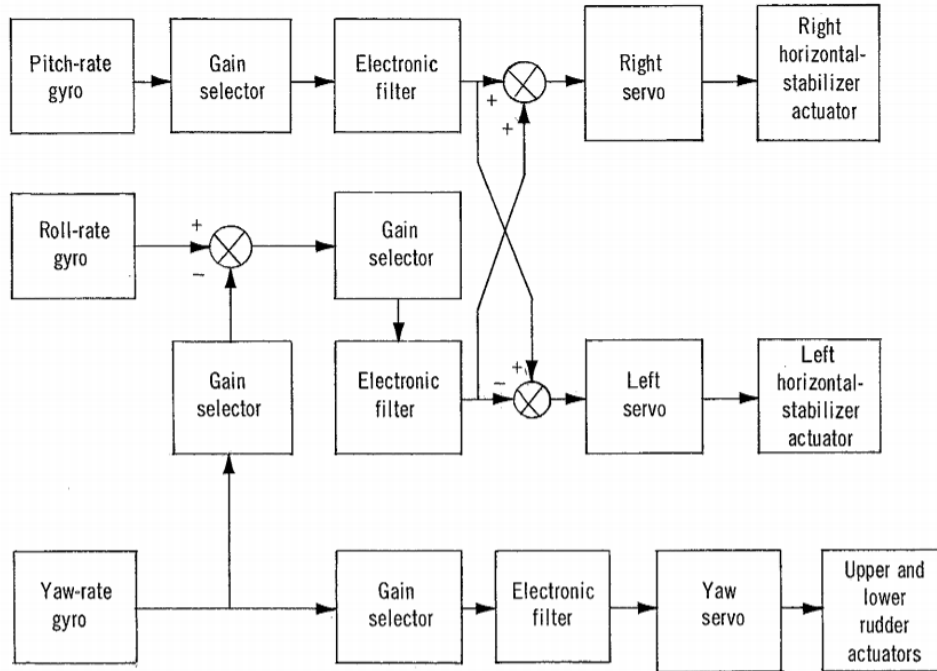

Figure 13: Functional diagram of the X-15 stability augmentation system from (NASA, 1969)

Structure and Mechanisms

(Doukas, McCandless, Sarafin, & Britton, 1999; Sarafin & Tagg, 2000)

The structure and associated mechanisms are the most outwardly visible part of the system hardware, responsible for holding the craft together. Included in this subsystem are fuselage, wings, stabilizers, doors, elevators, ailerons, rudders, spoilers, flaps, brakes, and drag devices. Commonly used materials include aluminum, titanium, magnesium, beryllium, steel, heat-resistant alloys, invar, and graphite.

Design must account for a number of material properties such as Young's modulus, shear modulus, ultimate tensile stress, yield stress, proportional limit, elongation, coefficient of thermal expansion, and fracture toughness. The materials are shaped into structures and mechanisms that are judged on their stiffness, positional stability, mass, strength, structural life, natural frequency,

damping, and mass properties. Possible failure modes include delayed operation, rubbing or fretting, high or low torque, binding or jamming, failure to extend/ or retract, failing mid-travel, inadvertent operation of pyros, and structural failure.

Command and Data Handling (C&DH)

(Berget & Turner, 1999; Comparetto, 2000)

The command and data handling subsystem is responsible for computational control aboard the spacecraft. These duties are covered by the computers and software on board. The computing systems utilized tend to be older than what is commercially available in consumer products because of the high reliability requirements. Design of C&DH should include consideration of data rate, bit-error rate, end-to-end delay, link availability, security, standardization, backward compatibility, access, and information source (voice, video, telemetry, and data) integration. Possible failure modes include system overload and erroneous output.

Telemetry, Tracking, and Command (TT&C)

(Pisacane & Moore, 1994; Ford, 1999)

The telemetry, tracking, and command subsystem is responsible for allowing the spacecraft to communicate with mission control. Associated hardware includes data transmitters and receivers, GPS hardware, voice communications, and antennas. There are several types of antennas that may be used, such as axial mode helix, bifilar or quadrifilar helix, parabolic dish, corrugated horn, biconal horn, conical log spiral, microstrip array, and halfwave dipole.

Design of this subsystem is largely based around trying to reduce the effects of noise on spacecraft-ground communications. Possible failure modes include antenna radiation pattern error or bandwidth anomaly, high or low signal, low electrical signal-to-noise ratio, and waveform, bias, or incorrect frequency.

Thermal Control System (TCS)

(Chapman, 1974; Ewert, Curry, Lin, & Brown, 2000)

The thermal control subsystem is responsible for regulating the heat inside and on the outer surface of the vehicle. The space environment does not allow for dynamic heat exchange between vehicle and atmosphere as occurs on Earth, so measures are taken to avoid overheating the interior of the spacecraft. These mechanisms include heat exchangers, coldplates, fluid pumps, heaters, radiators, boilers, flash evaporators, sublimators, and general insulation. Design is premised on efficient heat regulation and long-term reliability over many cycles. Possible failure modes include internal or external leakage, flow anomaly, and cavitation.

Power

(Griffin & French, 1991; Landis, McKissock, & Bailey, 2000; Patel, 2005)

For the systems to run, power must be provided and maintained. There are several options available to gather power in space, including solar photovoltaic, solar dynamic power, nuclear power, and fuel cells. Power is generally stored in batteries for later use as well. Possible failure modes include electrical current leak, loss of output or short circuit, and open, high resistance, high voltage or low current.

Environmental Control and Life Support System (ECLSS)

(Doll & Eckart, 2000)

A livable and working environment for humans within a spacecraft is monitored and maintained by ECLSS. This subsystem consists of hardware to monitor cabin materials, regulate a life-supporting breathing atmosphere and pressure, manage the water and food required by the crew, safely store the waste generated by human metabolism and crew activities, and control the temperature with the help of TCS. Possible failure modes include cavitation, internal or external leakage, flow anomaly, and failure of pressure maintenance

Thermal Protection System (TPS)

(Thornton, 1996; Ewert, Curry, Lin, & Brown, 2000; Condon, Tigges, & Cruz, 2000; The Aerospace Corporation, 2006)

The thermal protection subsystem is responsible for protecting the spacecraft as it reenters the atmosphere from space. During this mission phase, an extraordinary amount of heat is generated, usually more heat than most spacecraft structures would be able to handle without shielding. Four thermal protection methods are used most often: insulated radiative, insulative refractory, charring ablator, and absorptive transpiration. Peak heat load determines material and design. Design efforts are geared towards assuring that the TPS stays safe through all mission phases and will function effectively during reentry. Possible failure modes include loss of thermal protection during reentry, which can lead to loss of vehicle.

This review of subsystems tells us what needs to work and what can go wrong. The next step is to analyze which elements are more likely than others to fail. An examination of actual HS incident and accident data will underscore how CHS regulation should be targeted.

4.4 Incidents and accidents in human spaceflight

Risk analyses can provide theoretical probabilities of incident or accident, but the historical safety performance of HS falls short of those probabilities. The safety success rate for suborbital HS is perfect thus far in terms of fatalities, with 0 deaths among the 2 suborbital flights of Mercury, 2 of X-15⁴³, and 3 of SpaceShipOne. However, the full history of HS is less than safety-perfect (Pelton & Novotny, 2006).

As of April 2008, 483 humans have gone into space⁴⁴, of which 18 have died in-flight (3.726%). In terms of total people-trips, the 18 fatalities in 993 attempts make for a 1.813% fatality rate. (Launius & Jenkins, 2006). By other history-based calculations, current space

⁴³ The X-15 fatality occurred during a non-suborbital flight.

⁴⁴ By United States definition

systems have a 1.0-1.5%^{45,46} chance of fatal accident. Leaders in CHS believe the industry can achieve a level of safety equal to the early aviation industry. That metric would be at least 100 times safer than current spaceflight⁴⁷, and some predict as low as a 1-in-30,000 (0.003%) chance of an accident⁴⁸. While these rates would still not approach the safety level of commercial aviation cited in section 3.1, they would still represent a major improvement for both safety and industry likelihood of success.

More telling than probabilities, however, is actual flight accident and incident data. For the purposes of this section, only incidents and accidents that have occurred during one of the spaceflight phases already delineated will be discussed. The only CHS fatal accident to date, a testing accident by Scaled Composites that resulted in three deaths and three serious injuries⁴⁹, is tragic and noteworthy but is not included in this analysis as it is best classified as an industrial accident. The regulatory issues discussed here pertain more to protecting under-informed one-time participants rather than workers engaged in a dangerous industrial profession. We will also not focus on risk factors that are a) exclusively orbital such as pertaining to spacewalks (Alexei Leonov having great difficulty reentering the capsule after his Voskhod 2 spacewalk), b) missions that last longer and go farther (Apollo 13), or c) related to long duration HS (incidents on space station Mir).

Table 8 catalogues incidents and accidents throughout the history of HS that are most pertinent to current CHS regulatory issues. Though the history was researched thoroughly, the list is intentionally not comprehensive. This is done to keep focus on the most relevant historical examples that regulators should consider while drafting new rules.

⁴⁵ Wong, K. (2007, October 10). Working With COMSTAC To Develop An Appropriate Human Space Flight Safety Performance Target. *COMSTAC RLV Working Group Presentation*. Federal Aviation Administration.

⁴⁶ Foust, J. (2007, August 27). *Something dangerous and new*. Retrieved March 13, 2008, from The Space Review: <http://www.thespacereview.com/article/943/1>

⁴⁷ Foust, J. (2005, April 25). *Two scenarios and two concerns for personal spaceflight*. Retrieved March 13, 2008, from The Space Review: <http://www.thespacereview.com/article/362/1>

⁴⁸ Foust, J. (2007, August 27). *Something dangerous and new*. Retrieved March 13, 2008, from The Space Review: <http://www.thespacereview.com/article/943/1>

⁴⁹ Scaled Composites. (2008). *Press Release on Accident of July 26, 2007*.

Table 8: Incidents and accidents in human spaceflight chronologically

Date	Incident/Accident	Mission phase	Primary subsystem
4/12/1961	Vostok 1 service module remains attached to reentry module past planned separation (Jane's Information Group, 2003).	Reentry	Structure & Mechanisms
7/21/1961	Mercury 4 hatch blows prematurely after water landing, causing capsule to sink and near loss of astronaut (NASA, 1961).	Post landing	Structure & Mechanisms
3/18/1965	Voskhod 2 lands off-target in Ural Mountains when automatic descent system fails and crew is forced to spend a night in the capsule, surrounded by wolves (Grahm).	Reentry	Structure & Mechanisms
8/29/1965	Gemini 5 lands 169km short of target due to computer program error (NASA, 1965).	Landing	C&DH
3/17/1966	Gemini 8 goes into severe spin prior to reentry due to maneuvering thruster firing out of control (Jane's Information Group, 2003).	Space flight	ADCS & GNC
1/27/1967	Gus Grissom, Edward White II and Roger Chaffee are killed during Apollo 1 ground test when spark in cabin ignites fire that was exacerbated by all-oxygen environment (White T. G., 2000).	Pre launch	ECLSS
4/24/1967	Vladimir Komarov dies on Soyuz 1 when parachute fails on reentry and craft impacts ground (BBC; Associated Press, 2003).	Landing	Structure & Mechanisms
11/15/1967	Michael J. Adams dies on X-15 Flight 191 when plane goes into severe spin after electrical and control problems and breaks up during flight (Jenkins, 2000; Shayler, 2000).	Launch	ADCS & GNC
1/18/1969	Soyuz 5 service module remains attached to reentry module, causing reentry facing the wrong way and off-target landing (Oberg, 2002).	Reentry	Structure & Mechanisms
5/22/1969	Apollo 10 Lunar Module approaches gimbal lock when a GNC switch is flipped one too many times due to astronaut miscommunication and causes LM to gyrate wildly (Shayler, 2000).	Space flight	ADCS & GNC
11/14/1969	Apollo 12 is hit by lightning during ascent, causing several subsystems to temporarily fail (NASA, 1970).	Launch	Power
6/30/1971	Georgi Dobrovolski, Viktor Patsayev and Vladislav Volkov die on Soyuz 11 when cabin became depressurized while in space (NASA).	Space flight	ECLSS
4/5/1975	Soyuz 18a encounters a second stage separation failure on launch that causes crew to experience 21.3g acceleration during abort due to altitude error (Shayler, 2000).	Launch	Structure & Mechanisms
7/24/1975	Apollo-Soyuz Test Project (ASTP) US crew are nearly fatally exposed to nitrogen tetroxide (N ₂ O ₄) gas in capsule during descent due to switch left in wrong position (Redmond, 2004).	Landing	ECLSS
10/16/1976	Soyuz 23 lands in frozen lake and is dragged underwater by parachutes that fill with water (Wade, 2007).	Post landing	Structure & Mechanisms
9/26/1983	Soyuz T-10-1 aborts on launch pad and escape system carries crew to safety with 20g acceleration (Jane's Information Group, 2003).	Pre launch	Launch & Propulsion
12/8/1983	STS-9 has two General Purpose Computers (GPCs) short out after Reaction Control System (RCS) thruster jars piece of solder loose (NASA).	Space flight	C&DH
12/8/1983	STS-9 has two Auxiliary Power Units (APUs) fail after they catch on fire due to hydrazine leak during landing (Doherty, 1988).	Landing	Power
7/29/1985	STS-51-F experiences a main engine shutdown, nearly followed by a second one, due to a false high temperature reading, which caused the shuttle to Abort to Orbit (Dumoulin, 2001).	Launch	Launch & Propulsion

Date	Incident/Accident	Mission phase	Primary subsystem
1/28/1986	Space Shuttle Challenger explodes 73 seconds after takeoff due to faulty O-ring seal allowing hot gases to escape from the Solid Rocket Booster and cause the vehicle to break up, resulting in the deaths of crew of 7 (Vaughan, 1996).	Launch	Launch & Propulsion
9/6/1988	Soyuz TM-5 is stranded in orbit in the descent module for an extra day after an aborted deorbit due to sensor failure (Jane's Information Group, 2003).	Space flight	ADCS & GNC
7/23/1999	STS-93 suffers premature main engine cutoff due to an electrical short and a hydrogen leak, resulting in a lower orbit than planned (Dismukes, 2005).	Launch	Launch & Propulsion
2/1/2003	Space Shuttle Columbia breaks up on re-entry due to breach in leading edge of left wing where foam had impacted during lift-off, resulting in the deaths of crew of 7 (CAIB, 2003).	Reentry	TPS
6/21/2004	SpaceShipOne Flight 15P encounters a roll during flight, and noncritical collapse of an aerodynamic fairing (Chandler, 2004).	Launch	ADCS & GNC
9/29/2004	SpaceShipOne Flight 16P experiences rapid roll at Mach 2.7, causing flight control to recommend early engine shutdown (David, 2004).	Launch	ADCS & GNC
4/19/2008	Soyuz TMA-11's service module does not completely separate from the reentry vehicle, causing a wrong-way-facing reentry and 420 km off-target landing (Eckel, 2008).	Reentry	Structure & Mechanisms

Table references:

- Associated Press. (2003, February 1). Deadly accidents in the history of space exploration. Retrieved May 5, 2008, from USA Today: http://www.usatoday.com/news/nation/2003-02-01-accident-timeline_x.htm
- BBC. (n.d.). 1967: Russian cosmonaut dies in space crash. Retrieved May 5, 2008, from BBC On This Day: http://news.bbc.co.uk/onthisday/hi/dates/stories/april/24/newsid_2523000/2523019.stm
- CAIB. (2003). Columbia Accident Investigation Board Report. Arlington, VA: Columbia Accident Investigation Board.
- Chandler, D. L. (2004, June 22). 'Anomalies' in first private spaceflight revealed. Retrieved May 5, 2008, from NewScientist: <http://www.newscientist.com/article.ns?id=dn6052>
- David, L. (2004, September 29). Tense Moments During Trailblazing Private Space Flight. Retrieved May 5, 2008, from SPACE.com: http://www.space.com/missionlaunches/xprize_success_040929.html
- Dismukes, K. (2005, November 21). STS-93 Deploys Chandra X-Ray Observatory. Retrieved May 5, 2008, from Shuttle Archives: <http://spaceflight.nasa.gov/shuttle/archives/sts-93/>
- Doherty, R. (1988, September 6). NASA's close calls: lessons learned? Electronics Engineering Times , p. 4.
- Dumoulin, J. (2001, June 29). 51-F (19). Retrieved May 5, 2008, from Space Shuttle Missions: <http://science.ksc.nasa.gov/shuttle/missions/51-f/mission-51-f.html>
- Eckel, M. (2008, April 22). Russian news agency says Soyuz crew was in danger on descent. Retrieved May 5, 2008, from Associated Press: <http://ap.google.com/article/ALEqM5jJitDZhZSszTx3L37XQOplAlh8fGQD90725NO4>
- Grahn, S. (n.d.). The Voskhod 2 mission revisited. Retrieved May 5, 2008, from Space History Notes: <http://www.svengrahn.pp.se/histind/Voskhod2/Voskhod2.htm>

- Jane's Information Group. (2003, February 3). A brief history of space accidents. Retrieved May 5, 2008, from Jane's Transport Business News:
http://www.janes.com/aerospace/civil/news/jsd/jsd030203_3_n.shtml
- Jenkins, D. R. (2000). *Hypersonics Before the Shuttle: A Concise History of the X-15 Research Airplane*. Washington, DC: NASA.
- NASA. (1970). *Analysis of Apollo 12 Lightning Incident*. Springfield, VA: National Technical Information Service.
- NASA. (1965). *Gemini 5 Mission Report*. Houston, TX: Manned Spacecraft Center.
- NASA. (1961). *Results of the Second U.S. Manned Suborbital Space Flight*. Washington, DC: US Government Printing Office.
- NASA. (n.d.). Soyuz 11. Retrieved May 5, 2008, from NSSDC Master Catalog Search:
<http://nssdc.gsfc.nasa.gov/nmc/masterCatalog.do?sc=1971-053A>
- NASA. (n.d.). STS-9. Retrieved May 23, 2008, from Space Shuttle Mission Archives:
http://www.nasa.gov/mission_pages/shuttle/shuttlemissions/archives/sts-9.html
- Oberg, J. (2002, June). Soyuz 5's Flaming Return. *Flight Journal*, 7 (3), pp. 56-60.
- Redmond, C. (2004, October 22). The Flight of Apollo-Soyuz. Retrieved May 5, 2008, from The Apollo Missions: <http://www.hq.nasa.gov/office/pao/History/apollo/apsoyhist.html>
- Shayler, D. (2000). *Disasters and Accidents in Manned Spaceflight*. New York, NY: Springer-Praxis.
- Vaughan, D. (1996). *The Challenger Launch Decision Risky Technology, Culture, and Deviance at NASA*. Chicago, IL: University of Chicago Press.
- Wade, M. (2007). Soyuz 23. Retrieved May 5, 2008, from Encyclopedia Astronautica:
<http://www.astronautix.com/flights/soyuz23.htm>
- White, T. G. (2000). *The Establishment of Blame as Framework for Sensemaking in the Space Policy Subsystem: A Study of the Apollo 1 and Challenger Accidents*. Virginia Polytechnic Institute and State University. Blacksburg, VA: Unpublished Doctoral Thesis.

From this data, we are able to compile Figure 14 on the following page which illustrates this historical record graphically by mission phase (with labels denoting subsystem and year), and Table 9 which places incidents and accidents in a subsystem versus mission phase grid.

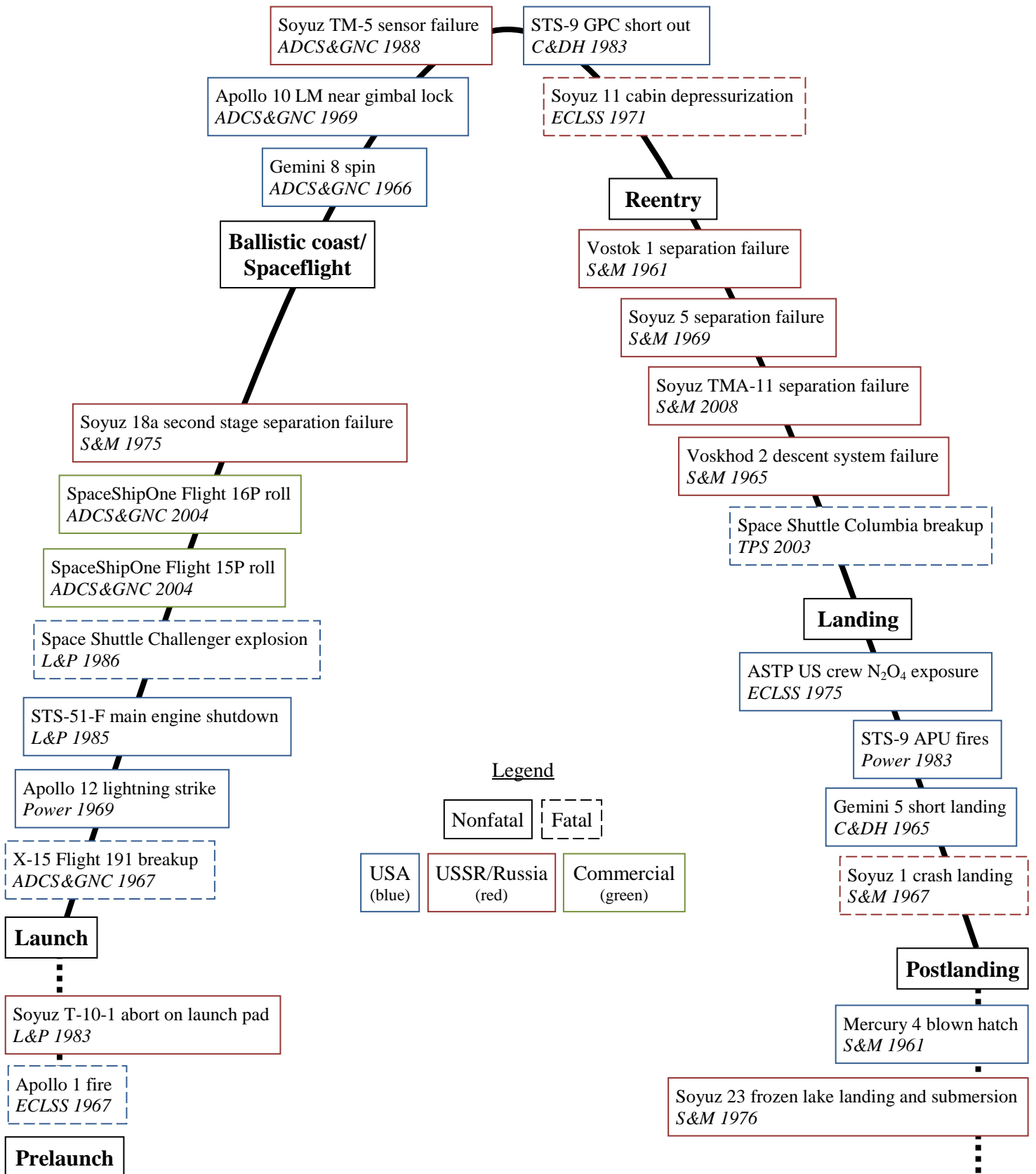

Figure 14: Incidents and accidents in human spaceflight by mission phase adapted and expanded from (Clark, 2007)

Table 9: Subsystems & mission phases, incidents & accidents, and criticality in HS

Subsystem	Mission phase						TOTAL
	Prelaunch	Launch	Ballistic coast/ Spaceflight	Reentry	Landing	Postlanding	
Launch & Propulsion	1	3					4
ADCS & GNC		3	3				6
Structure & Mechanisms		1		4	1	2	8
C&DH			1		1		2
TT&C							0
TCS							0
Power		1			1		2
ECLSS	1		1		1		3
TPS				1			1
TOTAL	2	8	5	5	4	2	

The evidence indicates certain “hot spots”: combinations of subsystems and mission phases where accidents and incidents are more likely to occur. The pie charts in Figure 15 below show that just 2 subsystems (Structure and Mechanisms, ADCS & GNC) are responsible for 54% of the instances, and with ECLSS and Launch & Propulsion added account for 80%. In terms of mission phases, just Launch and Ballistic coast/Spaceflight make for 50% of accidents and incidents.

Figure 15: Incidents and accidents in human spaceflight by percentages

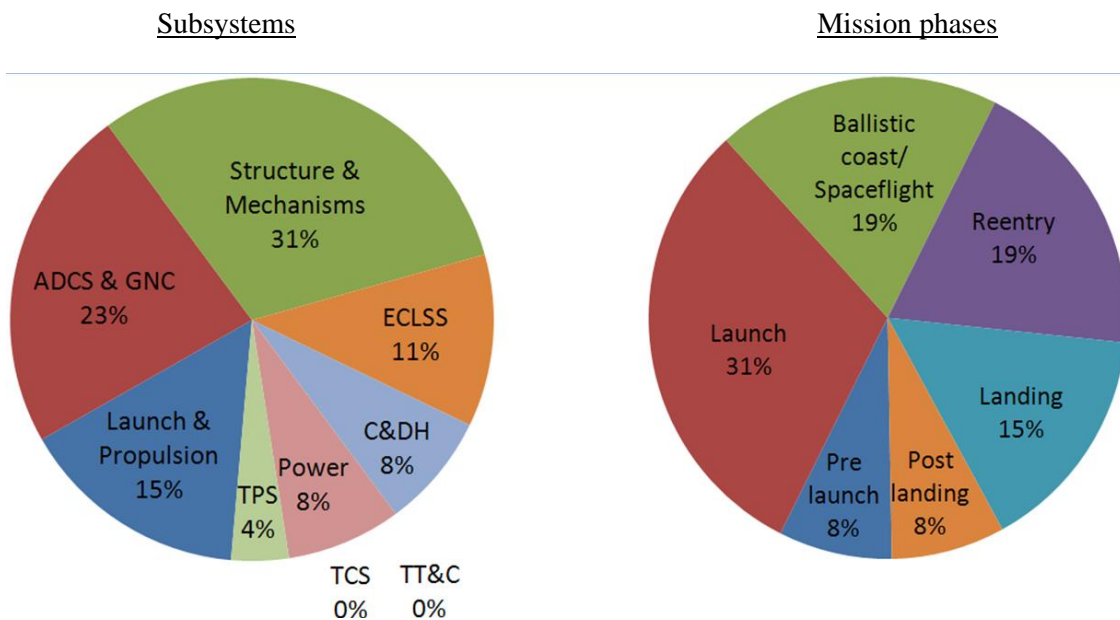

This data is important to note because probabilistic failure analysis informs CHS engineers about potential problems in the next flight, but government regulators must think in broader strokes about how decisions made now will have impact for years down the line. This sort of long-term trends analysis is an important tool for policy-makers to have at their disposal.

4.5 Mission safety criticality

This study of mission phases with their associated hazards, and subsystems with their responsibilities and potential failure modes, yields a matrix of which subsystems are most critical to mission success, and when. While ideally each subsystem performs nominally in every stage of the mission, there are certain combinations of mission phase and subsystem failure that pose a heightened risk to the full system. These are the nodes that should be targeted for regulation.

Table 10 on the following page lists problems that may occur at certain junctions (Heydorn & Railsback, 2000), and illustrates levels of safety criticality (Pelton, Smith, Helm, MacDoran, Caughran, & Logsdon, 2005) on a three-tiered scale: **Highly safety critical**, **Somewhat safety critical**, and *Less safety critical*. These distinctions should be understood to be relative to one another. A subsystem-mission phase combination labeled “less safety critical” is not immune to catastrophic failure, nor is a “highly safety critical” node a guarantee of it. Most aspects of HS are risky and have critical consequences of failure. This delineation simply helps to sort, among risky items, which should receive more attention.

This original analysis is not strictly quantitative. It is based on the observations of HS mission history that we have just reviewed, literature about subsystem vulnerabilities, and discussions with space systems engineers. It is primarily concerned with performance and safety issues that are more likely to exist in suborbital CHS.

Table 10: Subsystems, mission phases, and criticality

Subsystem	Mission phase					
	Prelaunch	Launch	Ballistic coast/ Spaceflight	Reentry	Landing	Postlanding
Launch & Propulsion	Premature operation	Fails to start Thrust anomaly Fails to stop Explosion			Fails to start (when used in landing)	Fails to stop (when used in landing)
ADCS & GNC	Premature operation	Operational anomaly Inadvertent operation Drift/shift Axis alignment or bias anomaly				Postlanding operation
Structure & Mechanisms		Deployment anomaly Rubbing/fretting; Torque high/low Binding/jamming; Fails to extend/retract Fails mid-travel Inadvertent operation of pyros Structural failure				
C&DH		System overload Erroneous output				
TT&C		Antenna radiation pattern error/bandwidth anomaly Signal high/low Electrical signal-to-noise ratio low Waveform, bias, or incorrect frequency				
TCS		Internal/external leakage Flow anomaly Cavitation				
Power		Loss of output				
ECLSS		Cavitation Internal/external leakage Flow anomaly Cabin pressure failure				
TPS			Thermal protection loss			

Legend:

Highly safety critical
Less safety critical
Somewhat safety critical

Table 10 illustrates nodes of mission safety criticality for CHS. There are 9 subsystems included and 6 mission phases, making for 54 combinations of the two. Of these, 21 (39%) are deemed highly safety critical, 14 (26%) are labeled somewhat safety critical, and 19 (35%) are less safety critical. The breakdown between these three tiers is illustrated in Figure 16.



Figure 16: Safety criticality breakdown

If these safety criticality delineations are accepted, it is clear that some risk factors are more pressing than others. In Table 10, TT&C is less safety critical for the entire mission, while Structure & Mechanisms are highly safety critical for each moment following pre-launch. ADCS & GNC, Power, and ECLSS are highly safety critical for the majority of the mission, while C&DH and TCS are important but not of the utmost safety criticality for a suborbital trajectory. Some of the subsystems are highly safety critical only at key moments, such as Launch & Propulsion during the beginning and end of the mission and TPS during reentry.

The accident and incident data in Table 9 maps to the safety criticality model in Table 10 to create Table 11 on the following page. Seeing the two former tables combined in the latter, the historical data begins to justify the criticality delineations.

Table 11: Subsystems & mission phases, incidents & accidents, and criticality in HS

Subsystem	Mission phase					
	Prelaunch	Launch	Ballistic coast/ Spaceflight	Reentry	Landing	Postlanding
Launch & Propulsion	1	3				
ADCS & GNC		3	3			
Structure & Mechanisms		1		4	1	2
C&DH		1			1	
TT&C						
TCS						
Power		1			1	
ECLSS	1		1		1	
TPS				1		

Legend:

Highly safety critical	
<i>Less safety critical</i>	Somewhat safety critical

Each of the cells with more than one accident or incident is “highly safety critical”, while none of the “less safety critical” cells has any mishaps. The rest of the accidents and incidents, where there is only one instance in a cell, are spread between “highly safety critical” and “somewhat safety critical”. There are also instances of cells of all three criticality levels with no accident or incident noted. Those were assigned for a number of other reasons, from notes in the literature to discussions with space systems engineers.

While not perfect, and certainly judgment-based enough to invite discussion, this model provides a solid starting point for CHS safety regulators. Every government agency is resources-constrained, and being able to target certain mission phase-subsystem nodes allows government agents to utilize their limited resources most effectively to protect safety. Chapter 5 will conclude this discussion and propose conclusions aimed towards government regulators based on this work.

CHAPTER 5: CONCLUSIONS AND RECOMMENDATIONS

The discussion to this point has touched on a wide variety of subjects that, taken together, will help us consider the most pertinent issues in government regulation and oversight for the protection of passenger safety in CHS. Topics have ranged from regulatory theory, to risk and safety theory, to CHS-analogous industries, to the evolution of the FAA, CS, and CHS, to the history of space incidents and accidents, to a technical look at the intersection of spacecraft subsystems, mission phases, and safety criticality.

This chapter will synthesize these topics to provide analysis for industrial actor and government regulator alike. From this discussion we will then draw conclusions and recommendations for the passenger safety regulation of CHS going forward.

5.1 Summary

We began by examining regulatory theory. Congress, empowered by the Commerce Clause of the United States Constitution, primarily regulates industries by authorizing independent commissions to make rules and execute oversight on its behalf. Because many industrial issues are highly technical, agency power is focused and deliberate. An agency serves a variety of stakeholders, including the regulated industry itself, which generally attempts to gain competitive advantage through the process, potentially resulting in regulatory capture.

Better rules are made when an agency is able to adapt to industrial changes and to balance the regulatory efficiency of centralized regulation with the industrial efficiency of customized regulations. Regulations should be clear, easy to understand, long-sighted, and flexible. Further, rules should be designed to not inherently pick winners. Rule types include prior approval, mandatory standards, information disclosure, and economic instruments.

Self regulation can be an attractive option to government under certain conditions. There must be a strong trade association, incentives for both government and industry to adopt this model, industry stability, and little anti-trust concern. Activities include information disclosure,

product rating, conduct coding, creating safety standards, and guarding against deception from firms. It is also regarded as effective in dealing with emerging technologies.

Risk and safety theory have also been central to this discussion. Personal risk perception can be inaccurate, and hinges on what an individual knows, doesn't know, and which risk factors they don't even know to learn more about. Though risk can be determined quantitatively, it must be put into context in order to have meaning to non-experts. Society is generally much more tolerant of voluntarily-assumed risk than involuntarily-imposed risks. Acceptable risk is the baseline amount of non-zero risk that is considered tolerable for carrying out an activity.

Informed consent sets the acceptable risk for an individual: assuring that he or she knows of the risks involved and accepts them as part of the activity. Uncertainty should also be explicitly spelt out, particularly with emerging technologies. New technologies bring with them new and uncertain risks. Regulatory decisions need to be made while often still lacking critical information or knowledge of long-term effects.

Managing risk can be based on utility, rights, or technology. Risk management in adventure activities should not stifle the activities altogether, but enough to protect both participants and operators. While risk assessment cannot be completely separated from risk management, they should not compromise one another's purposes.

There are other industries that can serve as analogies for regulating CHS. Adventure sports – specifically bungee jumping, hang gliding, and sky diving – are interesting because they are also high-risk recreational activities. Commercial aviation is another industry of interest because of its common operational medium, early entrepreneurial spirit, public safety concerns, innovative technology for its time, and government oversight through the FAA.

CHS is a new application of HS and CS. There are very few serious players as compared with almost any other emerging industry. While the industry has promise, it has not yet delivered groundbreaking results or enjoyed much public acclaim since the X-Prize. The

potential for success in the next several years, however, makes this an appropriate time to debate how passenger safety regulation going forward should be protected.

Regulation of CHS is a prerogative of the US due to its international treaty obligations/liability and its imperative to protect public and citizen safety. Protection of passenger safety for the CHS industry is primarily governed by the CSLAA and guided by the principle of informed consent. Stricter regulation of design and operations by FAA/AST is due to be allowed in 2012, though that date was set when it was believed that the first commercial flights could begin as early as 2006 rather than the current forecast of 2010.

Each CHS company utilizes a different technical design. With a variety of body types, take-off/landing modes, and staging schemes, the differences across the board are as significant as are the similarities of mission and operational medium. Spaceplanes seem to be an emerging popular option, though there is still little commonality among designs.

A suborbital space mission can be delineated into six mission phases and nine subsystems. The history of space incidents and accidents that are relevant to suborbital HS shows that these instances are more concentrated in some areas than others. The combinations of subsystems and mission phases can thus be broken down roughly into three categories of mission safety criticality, the more critical of which should be subject to closer scrutiny by regulators.

In this summary are drawn out the most important points of the previous four chapters. In the conclusions and recommendations section, we will synthesize these disparate ideas into a few main messages.

5.2 Conclusions and recommendations

5.2.1 Industrial analogies

CHS is not a “normal” industry to be regulated by Congress and its regulatory agencies in a pre-prescribed, cookie-cutter fashion. It has a set of characteristics that make it unique: a reliance on new and improved technologies, relatively very few serious firms, advanced enough notice of the industry’s start that regulation before operational commencements is an option, no standardization of design and operation as of yet, and the potential for catastrophic damage to both uninvolved public and willing participants.

It is similar to adventure sports as a high-risk recreational activity, where participant involvement is voluntary and undertaken with the knowledge of dangers inherent in the activity. Currently, the three adventure sports surveyed have a large degree of self regulation with government oversight, which may have been a result of the activities finding a need to protect participant safety before government involvement. CHS can take eventual lessons in self regulation from these industries, but cannot afford to only regulate in response to laxity in safety.

Early commercial aviation poses another interesting analogy. Both this industry and CHS operate (in part or in whole) in the national airspace. Both have had/are having a “barnstorming” era, where drawing public interest was just as important as furthering technology, and both have benefitted from federal promotion. In early aviation, standardization was initiated during wartime, while CHS will likely only standardize under government mandate or market forces coalescing around a superior design. There were early calls for regulation from the industry and interest groups to bring governmental authority to bear in protecting safety. The CHS industry seems more wary of early government regulation, though this may be due to differences in the regulatory environment between present day and the early-mid 20th century.

There are other interesting analogies that each relate to some aspect of CHS, such as nuclear power with its relatively small number of players yet catastrophic potential. The approach to CHS should begin with study of each of these analogies. But truly, CHS is an

activity and industry all its own and too much reliance on other models may lead to a misunderstanding of the unique technical and regulatory challenges that CHS presents.

Recommendations include:

- Care must be taken when regulating CHS using lessons from other analogous industries.
- Near-term CHS vehicles should be treated as suborbital spacecraft, not aircraft or orbital spacecraft. They have unique technical challenges, and recycling regulations that were designed for other industries will miss critical points.

5.2.2 Risk, safety, and society

While it is possible to derive reliability measures for each component of a technical system, and extrapolate a statistical probability for the failure of the system as a whole from this, these numbers must be placed in social and historical context. While most HS vehicles claim extremely small probabilities of failure, the fact remains that the historical chances of fatality during HS are larger than 1 in 70.

CHS will attract both relatively informed “space buff” and one-time thrill seeker, and no assumptions should be made as to what any of them knows before the flight. Theoretical (including uncertainty) and historical data should be given to a SFP to help them assess their willingness to participate in light of that information. Informed consent procedures should include enough information to make an educated choice, but not so much that a non-expert SFP will be overwhelmed with much more than the most necessary data.

CHS is not a single-point failure industry, but neither can it afford many mistakes. The industry’s fortunes are directly tied to its safety record. Safety should not be a competition between firms, as the industry cannot afford any safety “losers”. When a tiremaker’s tires blow out, consumers don’t stop driving altogether, but rather just buy from a competitor. Tires, however, are a necessity for people, whereas CHS is not. One or two firms’ failures can make potential SFPs reevaluate the activity as a whole and jeopardize the entire enterprise.

Recommendations include:

- Informed consent continues to be required, with federally standardized areas of information disclosure that are understandable to non-experts.
- Protocols are designed for both industry peers and government to deal with irresponsible actors.

5.2.3 Regulatory approach

We have discussed self regulation and its advantages. This model is useful for regulating emerging technologies because of its ability to gather and disseminate information effectively. Currently there is a trade organization in the Personal Spaceflight Federation, but it serves more to promote discussion than actually give orders with any sort of authority to the member firms.

At this point, CHS does not need/is not yet ready for self regulation. The industry is small enough that FAA/AST is able to collect the information it needs, and is not stable enough yet to initiate a self regulatory regime. However, the statutory regulation regime being developed can seek to marry the specificity and efficiency of self regulation with the power of government-backed statutory regulation.

Though this sort of system cannot last forever, FAA/AST should continue to regulate in a relatively ad-hoc, case-by-case manner for the time being. This would be a wise application of the agency's technical expertise in instances of change and uncertainty. By 2012, if not sooner due to serious incident or accident, they will have the authority to regulate design and operations across the board. However, it is increasingly unlikely that there will be sufficient data by that time or that the industry will be remotely homogeneous enough to warrant this.

Even if industry-wide regulation of design and operations to protect passenger safety is rolled in gradually, it is still likely to be instituted before the industry is fully mature. There will still be major differences between companies' approaches, making across-the-board regulation difficult. The three-tiered mission safety criticality model will prove useful as it can serve as a guide for where regulators should focus their energies. Specific designation of a mission phase-

subsystem node to a criticality level may change over time with technological advances and operational experience, but the principle behind the model remains.

Recommendations include:

- The 2012 start date for regulation of design and operations to protect passenger safety could be delayed, it could be replaced by an undated metric (i.e. number of companies in operation, number of flights taken, number of passengers flown, number of significant incidents, or frequency of flights), or FAA/AST could simply exercise good judgment in not creating more general rules until sufficient data is available
- The rule types of prior approval and information disclosure to participants should continue to be used. Economic instruments are not necessary yet. Great care should be taken to avoid mandatory standards that cause technological lock-in of any design or operational practice until they are conclusively shown to be optimal.
- FAA/AST should adopt a tiered mission safety criticality model that is general enough to help focus regulatory resources across the board but specific enough to regulate on an ad-hoc, case-by-case basis as needed until statutory generalizations are appropriate.

5.3 Future work

A good thesis raises more good questions than it answers. While this discussion has completely delved into one specific area of inquiry with regards to CHS and government protection of passenger safety, this field is very new and ripe with interesting questions.

Future academic work may consider developments in CHS, such as the technical achievement of orbital CHS and the policy implications of self regulation or regulatory capture. A deeper analysis of historical antecedents such as the X-15 and recycling of previous government efforts will also be useful, as the proverbial wheel is not likely to be reinvented with every entrant to the market.

A comprehensive review of all CHS technical systems once that data becomes publically available will bring to the fore even more questions. The framework offered here may be

insufficient to handle to diversity of CHS design and operational modes as more competitors enter the industry, and may need to be expanded.

A few more interesting questions include how the insurance industry will approach creating policies for this high-risk venture with very little actuarial data available, and how FAA-AST should deal with CHS operators based abroad who cater to US citizens. There is an enormous niche to be filled by answering these questions and others, with this thesis just a first shot at tackling an extraordinarily complex set of questions.

In a newly-emergent technical industry, changes occur rapidly. Parts of this thesis may be irrelevant within even a few years as technological, economic, political, and regulatory circumstances change. Hopefully this work will prove useful in the meantime.

REFERENCES

- Abraham, K. S. (1986). *Distributing Risk: Insurance, Legal Theory, and Public Policy*. New Haven, CT: Yale University Press.
- The Aerospace Corporation. (2006, December 22). *Spacecraft Reentry*. Retrieved May 19, 2008, from Center for Orbital and Reentry Debris Studies:
<http://www.aero.org/capabilities/cords/reentry-overview.html>
- AIAA. (2005). *Guide to the Identification of Safety-Critical Hardware Items for Reusable Launch Vehicle (RLV) Developers*. Reston, VA: American Institute of Aeronautics and Astronautics.
- AIAA-ANSI. (1999). *Commercial Launch Safety*. Reston, VA: American Institute of Aeronautics and Astronautics.
- Akerlof, G. A. (1970). The market for "lemons": Quality uncertainty and the market mechanism. *The Quarterly Journal of Economics*, 84 (3), 488-500.
- Allen, H. J., & Eggers, J. A. (1958). *NACA Report 1381: A Study of the Motion and Aerodynamic Heating of Ballistic Missiles Entering the Earth's Atmosphere at High Supersonic Speeds*. National Advisory Committee for Aeronautics.
- Andrews, W. L. (2001). *The Taxation of Space Commerce*. The Hague, Netherlands: Kluwer Law International.
- Apostolakis, G., Stamatelatos, M., & Dezfuli, H. (2006). A Proposed Risk-Informed Decision-Making Framework for NASA. *Eight International Conference on Probabilistic Safety Assessment and Management*. New Orleans, LA: PSAM 8.
- Ashby, S., Swee-Hoon, C., & Hoffman, R. (2004). Industry Self-Regulation: A Game-Theoretic Typology of Strategic Voluntary Compliance. *International Journal of the Economics of Business*, 11 (1), 91-106.
- Atkinson, J. (1957). Motivational Determinants of Risk-Taking Behavior. *Psychological Review*, 64 (6), 359-372.
- Baldwin, R. (1990). Why Rules Don't Work. *The Modern Law Review*, 53 (3), 321-337.
- BBC. (n.d.). *1967: Russian cosmonaut dies in space crash*. Retrieved May 5, 2008, from BBC On This Day:
http://news.bbc.co.uk/onthisday/hi/dates/stories/april/24/newsid_2523000/2523019.stm
- Becker, J. V. (1968, December 4-5). Retrieved April 25, 2008, from The X-15 Program in Retrospect: <http://www.hq.nasa.gov/office/pao/History/x15lect/toc.html>
- Benkö, M., & Schrogl, K.-U. (2005). *Space Law: Current Problems and Perspectives for Future Regulation*. Utrecht, the Netherlands: Eleven International Publishing.
- Bentley, T., Page, S. J., & Laird, I. (2003). Managing Tourist Safety: The Experience of the Adventure Tourism Industry. In J. Wilks, & S. J. Page, *Managing Tourist Health and Safety in the New Millennium* (pp. 85-100). Oxford, UK: Elsevier Science.
- Berget, R. T., & Turner, T. (1999). Command and Data Handling. In J. R. Wertz, & W. J. Larson, *Space Mission Analysis and Design* (pp. 380-390). Torrance, CA: Microcosm.
- Bernstein, M. H. (1955). *Regulating Business by Independent Commission*. Princeton, NJ: Princeton University Press.
- Booze Allen Hamilton. (2004). *Space Vehicle Operators Concept of Operations: A Vision to Transform Ground and Launch Operations*. Washington, DC: Future Interagency Range and Spaceport Technologies.

- Bostubayeva, A. (2003). *Analysis of Space Employee Risk Acceptance*. Rochester, NY: Rochester Institute of Technology.
- Brannigan, A. A., & McDougall, A. (1983). Peril and Pleasure in the Maintenance of a High Risk Sport: A Study of Hang-Gliding. *Journal of Sport Behavior* , 6 (1), 37-51.
- Briddon, A. E., Champie, E. A., & Marrison, P. A. (1974). *FAA Historical Fact Book: A Chronology, 1926-1971*. Washington, D.C.: Federal Aviation Administration, Office of Information Services.
- Buckley, R. (2006). *Adventure Tourism*. Wallingford, UK: CABI Publishing.
- Burkhardt, R. (1974). *CAB - The Civil Aeronautics Board*. Dulles International Airport, Va: Green Hills Publishing Company.
- Burkhardt, R. (1967). *The Federal Aviation Administration*. New York, NY: Frederick A. Praeger Publishers.
- CAIB. (2003). *Columbia Accident Investigation Board Report*. Arlington, VA: Columbia Accident Investigation Board.
- Cain, F. (2008, January 23). *Virgin Galactic Unveils SpaceShipTwo*. Retrieved May 19, 2008, from Universe Today: <http://www.universetoday.com/2008/01/23/virgin-galactic-unveils-spaceshiptwo/>
- Case, C. M., & Doll, S. C. (1990). Life Support Functions and Technology Analysis for Future Missions. *Intersociety Conference on Environmental Systems*. Williamsburg, VA: SAE International.
- Celsi, R. L., Rose, R. L., & Leigh, T. W. (1993). An exploration of high-risk leisure consumption through skydiving. *Journal of Consumer Research* , 20 (1), 1.
- Chapman, A. J. (1974). *Heat Transfer*. New York, NY: Macmillan.
- Cheron, E. J., & Ritchie, J. R. (1982). Leisure Activities and Perceived Risk. *Journal of Leisure Research* , 14 (2), 138-154.
- Clark, J. B. (2007). Incidents in Human Space Flight: "Having a Bad Day in Space". *Commercial Human Spaceflight Workshop, 78th Annual Scientific Meeting*. New Orleans, LA: Aerospace Medical Association.
- Cloppenborg, J. (2005). Legal Aspects of Space Tourism. In M. Benkö, & K.-U. Schrogl, *Space Law: Current Problems and Perspectives for Future Regulation* (pp. 191-214). Utrecht, the Netherlands: Eleven International Publishing .
- Cloutier, K. R., & Garvey, D. (2000). *Legal Liability and Risk Management in Adventure Tourism*. Kamloops, B.C.: Bhudak Consultants.
- Comparetto, G. M. (2000). Command, Control, and Communications Architecture. In W. J. Larson, & L. K. Pranke, *Human Spaceflight: Mission Analysis and Design* (pp. 869-905). New York, NY: McGraw-Hill.
- Condon, G., Tigges, M., & Cruz, M. I. (2000). Entry, Descent, Landing, and Ascent. In W. J. Larson, & L. K. Pranke, *Human Spaceflight: Mission Analysis and Design* (pp. 271-330). New York, NY: McGraw-Hill.
- Cox, D. F., & Stuart, R. J. (1964). Perceived Risk and Consumer Decision-Making: The Case of Telephone Shopping. *IO*, 113-125.
- Crouch, G. I. (2001). The Market for Space Tourism: Early Indications. *Journal of Travel Research* , 40 (2), 213-219.
- Crouch, G. I., Devinney, T. M., & Louviere, J. J. (2006). *Going Where No Tourist Going Where No Tourist Has Gone Before: The Future Demand for Space Tourism*. Australia: Future Choice Initiative.

- Crouch, G. I., Devinney, T. M., Louviere, J. J., & Islam, T. (2007). Modelling Consumer Choice Behaviour in Space Tourism. *Tourism Management*, under review.
- De Marchia, B., & Ravetz, J. R. (1999). Risk management and governance: a post-normal science approach. *Futures*, 31 (7), 743-757.
- Derby, S. L., & Keeney, R. L. (1990). Risk Analysis: Understanding "How Safe Is Safe Enough?". In T. S. Glickman, & M. Gough, *Readings in Risk*. Washington, DC: Resources for the Future.
- Dezfuli, H., Youngblood, R., & Reinert, J. (2007). Managing Risk Within a Decision Analysis Framework. *Second IAASS Conference*. Chicago, IL: NASA Headquarters, Office of Safety and Mission Assurance.
- DFI International. (2002). *Market Opportunities in Space: The Near Term Roadmap*. Washington, DC: DFI International.
- Dick, S. J., Garber, S., & Engel, H.-P. (2000, February 24). *Chronology*. Retrieved April 24, 2008, from X-15: Hypersonic Research at the Edge of Space: <http://history.nasa.gov/x15/cover.html>
- Dobbs, L., & Newquist, H. P. (2001). *Space: The Next Business Frontier*. New York, NY: Pocket Books.
- Doll, S., & Eckart, P. (2000). Environmental Control and Life Support Systems (ECLSS). In W. J. Larson, & L. K. Pranke, *Human Spaceflight: Mission Analysis and Design* (pp. 539-573). New York, NY: McGraw-Hill.
- Doukas, P. G., McCandless, J. R., Sarafin, T. P., & Britton, W. R. (1999). Structures and Mechanisms. In J. R. Wertz, & W. J. Larson, *Space Mission Analysis and Design* (pp. 430-468). Torrance, CA: Microcosm.
- Doyle, C. (1997). Self regulation and statutory regulation. *Business Strategy Review*, 8 (3), 35-43.
- Dudley, S. E., & Hays, S. L. (2007, September 19). Updated Principles for Risk Analysis. *Memorandum for the Heads of Executive Departments and Agencies*. Washington, DC, USA: Office of Management and Budget.
- Eisner, M. A. (1993). *Regulatory Politics in Transition*. Baltimore, MD: Johns Hopkins University Press.
- Esola, L. (2008, February 4). Managing risks taken to the extreme. *Business Insurance*, 42 (5), pp. 14-15.
- Ewert, A. (1987). Risk Recreation Poses New Management Problems. *Park Science*, 8 (1), 7-8.
- Ewert, A. (1989). *Outdoor Adventure Pursuits: Foundations, Models, and Theories*. Columbus, Ohio: Publishing Horizons.
- Ewert, A., & Hollenhorst, S. (1989). Testing the Adventure Model: Empirical Support for a Model of Risk Recreation Participation. *Journal of Leisure Research*, 21 (2), 124-139.
- Ewert, M. K., Curry, D. M., Lin, C. H., & Brown, R. G. (2000). Thermal Control. In W. J. Larson, & L. K. Pranke, *Human Spaceflight: Mission Analysis and Design* (pp. 513-537). New York, NY: McGraw-Hill.
- FAA/AST. (1995a). *Financial Responsibility for Reentry Vehicle Operations*. Washington, DC: Department of Transportation.
- FAA/AST. (1995b). *Hazard Analysis of Commercial Space Transportation*. Washington, DC: Federal Aviation Administration.

- FAA/AST. (2002a). *Liability Risk-Sharing Regime for U.S. Commercial Space Transportation Study and Analysis*. Washington, D.C.: U.S. Department of Transportation, U.S. Federal Aviation Administration, Associate Administrator for Commercial Space Transportation.
- FAA/AST. (2002b). *Commercial Space and Launch Insurance: Current Market and Future Outlook (from Quarterly Launch Report, Fourth Quarter)*. Federal Aviation Administration, Office of Commercial Space Transportation. Washington, D.C.: FAA.
- FAA/AST. (2003). *Guide to Reusable Launch Vehicle Safety Validation and Verification Planning*. Washington, DC: Federal Aviation Administration.
- FAA/AST. (2005a, February 11). Draft Guidelines for Commercial Suborbital Reusable Launch Vehicle Operations with Flight Crew. Washington, DC: Federal Aviation Administration.
- FAA/AST. (2005b, February 11). Draft Guidelines for Commercial Suborbital Reusable Launch Vehicle Operations with Space Flight Participants. Washington, DC: Federal Aviation Administration.
- FAA/AST. (2005c). *Guide to Probability of Failure Analysis for New Expendable Launch Vehicles*. Washington, DC: Federal Aviation Administration.
- FAA/AST. (2005d). *Guide to Verifying Safety-Critical Structures for Reusable Launch and Reentry Vehicles*. Washington, DC: Federal Aviation Administration.
- FAA/AST. (2005e). *Suborbital Reusable Launch Vehicles and Emerging Markets*. Washington, DC: Federal Aviation Administration.
- FAA/AST. (2005f). *Guide to Commercial Reusable Launch Vehicle Operations and Maintenance*. Washington, DC: Federal Aviation Administration.
- FAA/AST. (2005g). *Guide to Reusable Launch and Reentry Vehicle Reliability Analysis*. Washington, DC: Federal Aviation Administration.
- FAA/AST. (2006a). *Guide to Reusable Launch and Reentry Vehicle Software and Computing System Safety*. Washington, DC: Federal Aviation Administration.
- FAA/AST. (2006b, December 15). Human Space Flight Requirements for Crew and Space Flight Participants; Final Rule. *Federal Register*. Washington, DC: Department of Transportation.
- FAA/AST. (2007). *Financial Responsibility Requirements as Determined by the Maximum Probable Loss (MPL) Process*. Washington, DC: Federal Aviation Administration.
- FAA/AST. (2008a). *Commercial Human Spaceflight Crew Training Survey*. Washington, DC: Federal Aviation Administration.
- FAA/AST. (2008b). *The Economic Impact of Commercial Space Transportation on the U.S. Economy*. Federal Aviation Administration, Office of the Associate Administrator for Commercial Space Transportation. Washington, DC: U.S. Government Printing Office.
- Fabre, H. (2002). Insurance strategies for covering risks in outer space: a French perspective. *Space Policy*, 18 (4), 281-286.
- Faulkner, B. (2001). Towards a Framework for Tourism Disaster Management. *Tourism Management*, 22 (2), 135-147.
- Faulkner, B., Fredline, L., Jago, L., & Cooper, C. P. (2003). *Progressing Tourism Research: Aspects of tourism* (Vol. 9). Clevedon: Channel View Publications.
- Fink, S. (1986). *Crisis Management: Planning for the Inevitable*. New York, NY: American Management Association.
- Fischhoff, B., Slovic, P., Lichtenstein, S., Read, S., & Combs, B. (1978). How safe is safe enough? A psychometric study of attitudes towards technological risks and benefits. *Policy Sciences*, 9 (2), 127-152.

- Fischhoff, B., Lichtenstein, S., Slovic, P., Derby, S. L., & Keeney, R. L. (1981). *Acceptable Risk*. Cambridge, UK: Cambridge University Press.
- Fischhoff, B., Bostrom, A., & Quadrel, M. J. (1993). Risk Perception and Communication. *Annual Review of Public Health* , 14, 183-203.
- Ford, J. (1999). Communications. In J. R. Wertz, & W. J. Larson, *Space Mission Analysis and Design*. Torrance, CA: Microcosm.
- Fordyce, S. W. (1985). Insurance for Space Systems. *IEEE Journal on Selected Areas of Communications* , 3 (1), 211-214.
- Fortescue, P. W., Stark, J., & Swinerd, G. (2003). *Spacecraft Systems Engineering*. New York, NY: J. Wiley.
- Friendly, H. J. (1962). *The Federal Administrative Agencies: The Need for Better Definition of Standards*. Cambridge, MA: Harvard University Press.
- Furger, F. (1997). Accountability and Systems of Self-Governance: The Case of the Maritime Industry. *Law & Policy* , 19 (4), 445-476.
- Futron. (2002). *Space Tourism Market Study*. Bethesda, MD: Futron Corporation.
- Futron. (2006). *Suborbital Space Tourism Demand Revisited*. Bethesda, MD: Futron Corporation.
- GAO. (2006). *FAA Needs Continued Planning and Monitoring to Oversee the Safety of the Emerging Space Tourism Industry*. Washington, DC: Government Accountability Office.
- Garvin, D. (1983). Can Industry Self-Regulation Work? *California Management Review* , 25 (4), 37-52.
- Gerhard, M. (2005). National Space Legislation - Perspectives for Regulating Private Space Activities. In M. Benkö, & K.-U. Schrogl, *Space Law: Current Problems and Perspectives for Future Regulation* (pp. 75-90). Utrecht, the Netherlands: Eleven International Publishing.
- gizmag. (2008, February 4). *SS2 technical snapshot*. Retrieved May 19, 2008, from SpaceShipTwo heading for 2008 test flight: <http://www.gizmag.com/spaceshiptwo-virgin-galactic/8753/picture/42024/>
- Glaese, J., Eterno, J. S., Zermuehlen, R. O., & Zimbelman, H. F. (2000). Attitude Determination and Control. In W. J. Larson, & L. K. Pranke, *Human Spaceflight: Mission Analysis and Design* (pp. 607-641). New York, NY: McGraw-Hill.
- Gnoth, J. (1997). Tourism motivation and expectation formation. *Annals of Tourism Research Volume* , 24 (2), 283-304.
- Goehlich, R. A. (2002). *Tourism, Space Tourism: Economic and Technical Evaluations of Suborbital Space Flight for*. Osnabrück, Germany: Der Andere Verlag.
- Goehlich, R. A. (2004). Part 9: Suborbital Rocket Plane. *S.P.A.C.E. Tourism Lecture Series* . Kohoku-ku, Yokohama, Japan.
- Goldstein, B. D. (1996). Risk Assessment as an Indicator for Decision Making. In R. Hahn, *Risks, Costs, and Lives Saved: Getting Better Results from Regulation* (pp. 67-84). Oxford, UK: Oxford University Press.
- Graham, J. D. (1996). Making Sense of Risk: An Agenda for Congress. In R. W. Hahn, *Risks, Costs, and Lives Saves: Getting Better Results from Regulation* (pp. 183-207). Oxford, UK: Oxford University Press.
- Gray, K. M. (2006). *Applications for Effective Business Planning in Adventure Tourism*. California State University, Chico, Interdisciplinary Studies. Chico, CA: Unpublished Masters Thesis.

- Gress, R. K. (2002a, August 16). The Early Years, AST - A Historical Perspective. *2002 Commercial Space Transportation Lecture Series , 1-3 , 2-20*. Washington, DC: Federal Aviation Administration.
- Gress, R. K. (2002b, September 13). Setting Insurance Requirements: Maximum Probable Loss. *2002 Commercial Space Transportation Lecture Series , 1-3 , 43-63*. Washington, DC, USA: Federal Aviation Administration.
- Griffin, M. D., & French, J. R. (1991). *Space Vehicle Design*. Washington, DC: American Institute of Aeronautics and Astronautics.
- Guastello, S. J. (2006). *Human Factors Engineering and Ergonomics: A Systems Approach*. Mahwah, NJ: Lawrence Erlbaum Associates.
- Gunningham, N., & Rees, J. (1997). Industry Self-Regulation: An Institutional Perspective. *Law and Policy , 19 (4)*, 363-414.
- Gupta, A. K., & Lad, L. J. (1983). Industry Self-Regulation: An Economic, Organizational, and Political Analysis. *The Academy of Management Review , 8 (3)*, 416-425.
- Gutman, B., & Frederick, S. (2002). *Being Extreme: Thrills and Dangers in the World of High-Risk Sports*. New York, NY: Kensington Publishing Corp.
- Hahn, R. W. (1996). *Risks, Costs, and Lives Saved: Getting Better Results from Regulation*. Oxford, UK: Oxford University Press.
- Hahn, R. W. (1998). Policy Watch: Government Analysis of the Benefits and Costs of Regulation. *The Journal of Economic Perspectives , 12 (4)*, 201-210.
- Haimes, Y. Y. (2004). *Risk Modeling, Assessment, and Management*. Hoboken, NJ: Wiley-Interscience.
- Heimer, C. A. (1988). Social Structure, Psychology, and the Estimation of Risk. *Annual Review of Sociology , 14*, 491-517.
- Hemphill, T. A. (1992). Self-Regulating Industry Behavior: Antitrust Limitations and Trade Association Codes of Conduct. *Journal of Business Ethics , 11*, 915-920.
- Hermida, J. (2004). *Legal Basis For a National Space Legislation*. Dordrecht, The Netherlands: Kluwer Academic Publishers.
- Hermida, J. (1997). Risk management in commercial launches. *Space Policy , 13 (2)*, 145-152.
- Heydorn, R. P., & Railsback, J. W. (2000). Safety of Crewed Spaceflight. In W. J. Larson, & L. K. Pranke, *Human Spaceflight: Mission Analysis and Design* (pp. 193-212). New York, NY: McGraw-Hill.
- Hilton, G. W. (1972). The Basic Behavior of Regulatory Commissions. *The American Economic Review , 62 (1/2)*, 47-54.
- Hollman, K. W., & Forrest, J. E. (1991). Risk Management in a Service Business. *International Journal of Service Industry Management , 2 (2)*.
- Holyfield, L., Jonas, L., & Zajicek, A. (2005). Adventure Without Risk Is Like Disneyland. In S. Lyng, *Edgework: The Sociology of Risk-Taking* (pp. 173-186). New York, NY: Routledge.
- Houston, R. S., Hallion, R. P., & Boston, R. G. (1998). *The Hypersonic Revolution: Case Studies in the History of Hypersonic Technology*. (A. F. Program, Editor) Retrieved April 25, 2008, from Transiting from Air to Space: The North American X-15: <http://www.hq.nasa.gov/office/pao/History/x15conf/toc.html>
- Hudgins, E. L. (2002). *Space: The Free-Market Frontier*. Washington, D.C.: Cato Institute.
- Hudson, S. (2003). *Sport and Adventure Tourism*. New York, NY: Haworth Hospitality Press.
- Hughes, P. C. (1986). *Spacecraft Attitude Dynamics*. New York, NY: J. Wiley.

- Hughes, T. R., & Rosenberg, E. (2005). Space Travel Law (and Politics): The Evolution of the Commercial Space Launch Amendments Act of 2004. *Journal of Space Law* , 31 (1), 1-79.
- Humble, R. W. (2000a). Propulsion Systems. In W. J. Larson, & L. K. Pranke, *Human Spaceflight: Mission Analysis and Design* (pp. 761-796). New York, NY: McGraw-Hill.
- Humble, R. W. (2000b). Selecting Launch and Transfer Vehicles. In W. J. Larson, & L. K. Pranke, *Human Spaceflight: Mission Analysis and Design* (pp. 797-810). New York, NY: McGraw-Hill.
- IAASS. (2007). *An ICAO for Space?* Noordwijk, The Netherlands: International Association for the Advancement of Space Safety.
- Independent Space Safety Board. (2006). *Space Safety Standard Commercial Manned Spacecraft*. Houston, TX: International Association for the Advancement of Space Safety.
- International Space University. (2000). *The Space Transportation Market: Evolution or Revolution?* (Vol. 5). (M. J. Rycroft, Ed.) Dordrecht, Netherlands: Kluwer Academic.
- Jack, S. J., & Ronan, K. R. (1998). Sensation Seeking Among High- and Low-Risk Sports Participants. *Personality and Individual Differences* , 25 (6), 1063-1083.
- Jasanoff, S. (1986). *Risk Management and Political Culture: A Comparative Study of Science in the Policy Context*. New York, NY: Russell Sage Foundation.
- Jasanoff, S. (1993). Relating risk assessment and risk management: Complete separation of the two processes is a misconception. *EPA Journal* , 19 (1), 35-37.
- Jenkins, D. R. (2000). *Hypersonics Before the Shuttle: A Concise History of the X-15 Research Airplane*. Washington, DC: NASA.
- Jenkins, D. R., Landis, T., & Miller, J. (2003). *American X-Vehicles: An Inventory - X-1 to X-50*. Washington, DC: NASA.
- Jordan, J., & Antuñano, M. (2003, March 31). Guidance for Medical Screening of Commercial Aerospace Passengers. *DOT-FAA Memorandum* . Oklahoma City, OK.
- Kayser, V. (2001). *Launching Space Objects: Issues of Liability and Future Prospects* (Vol. 1). (S. r. library, Ed.) Boston, MA: Kluwer Academic Publishers.
- Kerrest, A. (2005). Liability for Damage Caused by Space Activities. In M. Benkö, & K.-U. Schrogl, *Space Law: Current Problems and Perspectives for Future Regulation* (pp. 91-112). Utrecht, the Netherlands: Eleven International Publishing.
- Knutson, T. (2007). What is "Informed Consent" in for Space-Flight Participants in the Soon-to-be-Launched Space Tourism Industry? *Journal of Space Law* , 33 (1), 105-122.
- Kohlmeier, L. M. (1969). *The Regulators: Watchdog Agencies and the Public Interest*. New York, NY: Harper & Row Publishers, Inc.
- Komons, N. A. (1978). *Bonfires to Beacons: Federal Civil Aviation Policy Under the Air Commerce Act, 1926-1938*. Washington, D.C.: U.S. Dept. of Transportation, Federal Aviation Administration.
- Kranzberg, M., & Davenport, W. H. (1972). *Technology and Culture: An Anthology*. New York, NY: Schocken Books.
- LaBel, K. A., & Gates, M. M. (1996). Single-Event-Effect Mitigation from a System Perspective. *IEEE Transactions on Nuclear Science* , 43 (2.1), 654-660.
- Lambright, W. H. (2003). *Space Policy in the Twenty-First Century*. Baltimore, MD: Johns Hopkins University Press.
- Landis, G. A., McKissock, B. I., & Bailey, S. G. (2000). Designing Power Systems. In W. J. Larson, & L. K. Pranke, *Human Spaceflight: Mission Analysis and Design* (pp. 643-664). New York, NY: McGraw-Hill.

- Larson, W. J., & Pranke, L. K. (2000). *Human Spaceflight: Mission Analysis and Design*. New York, NY: McGraw-Hill.
- Launius, R. D. (2003). Between a Rocket and a Hard Place: The Challenge of Space Access. In W. H. Lambright, *Space Policy in the Twenty-First Century* (pp. 15-54). Baltimore, MD: The Johns Hopkins University Press.
- Launius, R. D., & Jenkins, D. R. (2006). Is it Finally Time for Space Tourism? *Astropolitics* , 4, 253-280.
- Lave, L. B. (1982). *Quantitative Risk Assessment in Regulation*. Washington, DC: The Brookings Institution.
- Lenox, M. J., & Nash, J. (2003). Industry self-regulation and adverse selection, a comparison across four trade association programs. *Business Strategy and the Environment* , 12, 343-356.
- Leveson, N. (1995). *SafeWare: System Safety and Computers*. Reading, MA: Addison-Wesley.
- Loverseed, H. (1997). The adventure travel industry in North America. *Travel & Tourism Analyst* , 6, 87-104.
- Lowrance, W. W. (1976). *Of Acceptable Risk: Science and the Determination of Safety*. Los Angeles, CA: William Kaufmann, Inc.
- Lyng, S. (1990). Edgework: A Social Psychological Analysis of Voluntary Risk Taking. *The American Journal of Sociology* , 95 (4), 851-886.
- Macauley, M. K. (2005, April 20). Space Commerce in the 21st Century. *Statement for Hearing of House Committee on Science, Subcommittee on Space and Aeronautics* . Washington, DC: Resources for the Future.
- Maitland, I. (1985). The Limits of Business Self-Regulation. *California Management Review* , 27 (3).
- Marais, K. (2005, June 23). A New Approach to Risk Analysis with a Focus on Organizational Risk Factors. Cambridge, MA: Unpublished doctoral thesis.
- McAvoy, L. H., & Dustin, D. L. (1985). Regulating Risks in the Nation's Parks. *Trends* , 22 (3), 27-30.
- McCraw, T. K. (1984). *Prophets of Regulation: Charles Francis Adams, Louis D. Brandeis, James M. Landis, Alfred E. Kahn*. Cambridge, MA: Belknap Press of Harvard University Press.
- McEwen, D. N. (1983). Being high on public land: rock climbing and liability. *Parks & Recreation* , 18 (10), 46-50.
- Meier, J. F. (1978). Is the Risk Worth Taking? *Journal of Physical Education and Recreation* , 49 (4), 31-33.
- Meyer, R. X. (1999). *Elements of Space Technology for Aerospace Engineers*. San Diego, CA: Academic Press.
- Mitchell, R. G. (1983). *Mountain Experience: The Psychology and Sociology of Adventure*. Chicago, IL: University of Chicago Press.
- Moolman, V. (1980). *The Road to Kitty Hawk*. Alexandria, VA: Time-Life Books.
- Moran, M. (2002). Understanding the Regulatory State. *British Journal of Political Science* , 32, 391-413.
- Morgan, D. (2000). Adventure tourism activities in New Zealand: perceptions and management of client risk. *Tourism Recreation Research* , 25 (3), 79-89.
- Morgan, M. G., Henrion, M., Morris, S. C., & Amaral, D. A. (1985). Uncertainty in risk assessment. *Environmental Science & Technology* , 19 (8), 662-667.

- Morgan, M. G., & Henrion, M. (1990). *Uncertainty: A Guide to Dealing with Uncertainty in Quantitative Risk and Policy Analysis*. Cambridge, UK: Cambridge University Press.
- Morgan, M. G. (1993). Risk Analysis and Management. *Scientific American* , 269 (1), 24-30.
- Muller, T. E., & Cleaver, M. (2000). Targeting the CANZUS Baby Boomer Explorer and Adventurer Segments. *Journal of Vacation Marketing* , 6 (2), 154-169.
- Murphy, P. E., & Bayley, R. (1989). Tourism and Disaster Planning. *Geographical Review* , 79 (1), 36-46.
- Murray, D. P. (2006). A Tiered Approach to Flight Safety Analysis. *AIAA Atmospheric Flight Mechanics Conference and Exhibits* (pp. 1-11). Keystone, CO: AIAA.
- NASA. (1961). *Results of the Second U.S. Manned Suborbital Space Flight*. Washington, DC: US Government Printing Office.
- NASA. (1965). *Gemini 5 Mission Report*. Houston, TX: Manned Spacecraft Center.
- NASA. (1969). *Entry Vehicle Control*. Washington, DC: National Aeronautics and Space Administration.
- NASA. (1970). *Analysis of Apollo 12 Lightning Incident*. Springfield, VA: National Technical Information Service.
- NASA. (2008). *Human-Rating Requirements for Space Systems*. Washington, DC: National Aeronautics and Space Administration.
- Nash, R. (1985). Proceed at your own risk. *National Parks* , 59 (1), 18-19.
- National Research Council. (1983). *Risk Assessment in the Federal Government: Managing the Process*. Washington, DC: National Academy Press.
- Nelkin, D. (1989). Communicating Technological Risk: The Social Construction of Risk Perception. *Annual Review of Public Health* , 10, 95-113.
- Noton, M. (1998). *Spacecraft Navigation and Guidance*. London, UK: Springer.
- Nunez, J. (2001). A Model of Self-Regulation. *Economics Letters* , 74 (1), 91-97.
- O'Connor, D., & Swenson, J. (1997). *Safety and Oversight of Amusement Rides in California*. Sacramento, CA: California Research Bureau, California State Library.
- OECD. (2004). *Space 2030: Exploring the Future of Space Applications*. Paris, France: Organisation for Economic Co-operation and Development.
- Ogus, A. (2002). Regulatory Institutions And Structures. *Annals of Public and Cooperative Economics* , 73 (4), 627-648.
- Ogus, A. (1995). Rethinking Self-Regulation. *Oxford Journal of Legal Studies* , 15 (1), 97-108.
- Olson, M. (1965). *The Logic of Collective Action: Public Goods and the Theory of Groups*. Cambridge, MA: Harvard University Press.
- OMB. (2007, September 19). OMB and OSTP Statements on Updated 1995 Principles for Risk Analysis. Washington, D.C., USA: Office of Management and Budget.
- Otway, H. J. (1982). Beyond Acceptable Risk: On the Social Acceptability of Technologies. *Policy Sciences* , 14, 247-256.
- Pace, S. N. (2003). The Future of Space Commerce. In W. H. Lambright, *Space Policy in the Twenty-First Century* (pp. 55-88). Baltimore, MD: The Johns Hopkins University Press.
- Palmer, C. (2002). 'Shit happens': The Selling of Risk in Extreme Sport. *The Australian Journal of Anthropology* , 13 (3), 323-336.
- Patel, M. R. (2005). *Spacecraft Power Systems*. Boca Raton, FL: CRC Press.
- Pavleka, E. L. (2000). Mission Operations for Crewed Spaceflight. In W. J. Larson, & L. K. Pranke, *Human Spaceflight: Mission Analysis and Design* (pp. 811-867). New York, NY: McGraw-Hill.

- Pelton, J. N., Smith, D., Helm, N., MacDoran, P., Caughran, P., & Logsdon, J. (2005). *Space Safety Report: Vulnerabilities and Risk Reduction In U.S. Human Space Flight Programs*. Washington, DC: Space & Advanced Communications Research Institute.
- Pelton, J. N., & Novotny, E. (2006). *NASA's Space Safety Program: A Comparative Assessment of Its Processes, Strengths and Weaknesses, and Overall Performance*. Washington, DC: Space & Advanced Communications Research Institute.
- Pelton, J. N. (2007). *Space Planes and Space Tourism: The Industry and the Regulation of its Safety*. George Washington University. Washington, DC: Space & Advanced Communications Research Institute.
- Perrow, C. (1984). *Normal Accidents: Living with High-Risk Technologies*. Princeton, N.J.: Princeton University Press.
- Petro, A. J. (1992). Concepts for a Personnel Launch System. *AIAA Space Programs and Technologies Conference*. Huntsville, AL: American Institute of Aeronautics and Astronautics.
- Petro, A. J. (2000). Transfer, Entry, Landing, and Ascent Vehicles. In W. J. Larson, & L. K. Pranke, *Human Spaceflight: Mission Analysis and Design* (pp. 391-420). New York, NY: McGraw-Hill.
- Pisacane, V. L., & Moore, R. C. (1994). *Fundamentals of Space Systems*. New York, NY: Oxford University Press.
- Power, M. (2004). The nature of risk: The risk management of everything. *Balance Sheet* , 12 (5), 19-28.
- Poynter, D. (1974). *Hang Gliding: The Basic Handbook of Skysurfing*. North Quincy, MA: Poynter.
- Price, A. B. (1968). *Design Report - Thermal Protection System X-15A-2*. Denver, CO: Martin Marietta Corporation.
- Priest, S., & Baillie, R. (1987). Justifying the Risk to Others: The Real Razor's Edge. *Journal of Experiential Education* , 10 (1), 16-22.
- Priest, S., & Gass, M. A. (1997). *Effective Leadership in Adventure Programming*. Champaign, IL: Human Kinetics.
- Priest, S. (2001). The Semantics of Adventure Programming. In J. Miles, & S. Priest, *Adventure Programming*. State College, Pa: Venture Publishing.
- Riley, F. E., & Sailor, J. D. (1962). *Space Systems Engineering*. New York, NY: McGraw-Hill.
- Robinson, D. (1992). A descriptive model of enduring risk recreation involvement. *Journal of Leisure Research* , 24(1), 52-63.
- Rossi, B., & Cereatti, L. (1993). The Sensation Seeking in Mountain Athletes as Assessed by Zuckerman's Sensation Seeking Scale. *International Journal of Sport Psychology* , 24, 417-431.
- Rowe, W. D. (1988). *An Anatomy of Risk*. Malabar, FL: Robert E. Krieger Publishing Company.
- Ryan, C. (2003). Risk Acceptance in Adventure Tourism - Paradox and Context. In J. Wilks, & S. J. Page, *Managing Tourist Health and Safety in the New Millenium* (pp. 55-66). Oxford, UK: Elsevier Science.
- Sagan, S. D. (1993). *The Limits of Safety*. Princeton, NJ: Princeton University Press.
- Salin, P. A. (2001). Privatization and Militarization in the Space Business Environment. *Space Policy* , 17 (1), 19-26.
- Sapolsky, H. M. (1990). The Politics of Risk. *Daedalus* , 119 (4), 83-96.

- Sarafin, T. P., & J., L. (1995). *Spacecraft Structures and Mechanisms: from Concept to Launch*. Torrance, CA: Microcosm.
- Sarafin, T. P., & Tagg, J. M. (2000). Structures. In W. J. Larson, & L. K. Pranke, *Human Spaceflight: Mission Analysis and Design* (pp. 665-705). New York, NY: McGraw-Hill.
- Schrader, M. P., & Wann, D. L. (1999). High-Risk Recreation: The Relationship between Participant Characteristics and Degree of Involvement. *Journal of Sport Behavior* , 22 (3), 426.
- Schuck, P. H. (1994). Rethinking Informed Consent. *The Yale Law Journal* , 103 (4), 899-959.
- Shaffer, B. (1995). Firm-Level Responses to Government Regulation: Theoretical and Research Approaches. *Journal of Management* , 21 (3), 495.
- Shayler, D. (2000). *Disasters and Accidents in Manned Spaceflight*. New York, NY: Springer-Praxis.
- Sheffi, Y. (2005). *The Resilient Enterprise: Overcoming Vulnerability for Competitive Advantage*. Cambridge, MA: MIT Press.
- Shoham, A., Rose, G., & Kahle, L. (2000). Practitioners of Risky Sports. *Journal of Business Research* , 47 (3), 237.
- Simberg, R. (2000). *Near-Term Prospects for Space Tourism*. Jackson Hole, WY: Interglobal Space Lines.
- Singh, T. V. (2004). *New Horizons in Tourism: Strange Experiences and Stranger Practices*. Cambridge, MA: CABI Publishing.
- Sjoberg, L. (2000). Factors in Risk Perception. *Risk Analysis* , 20 (1), 1-11.
- Slanger, E., & Rudestam, K. E. (1997). Motivation and Disinhibition in High Risk Sports: Sensation Seeking and Self-Efficacy. *Journal of Research in Personality* , 31 (3), 355-374.
- Stamatelatos, M., & Dezfuli, H. (2008). A Paradigm Shift in System Safety Processes at NASA. *7th National Space Systems Engineering & Risk Management Symposium*. Los Angeles, CA: NASA Headquarters, Office of Safety and Mission Assurance.
- Starr, C. (1969). Social Benefit versus Technological Risk. *Science* , 165 (3899), 1232-1238.
- Starr, C., & Whipple, C. (1980). Risks of Risk Decisions. *Science* , 208 (4448), 1114-1119.
- Starzyk, J. (2006, June 7). A Fresh Look at Space Tourism Demand. London, UK: Royal Aeronautical Society.
- Stigler, G. J. (1971). The Theory of Economic Regulation. *The Bell Journal of Economics and Management Science* , 2 (1), 3-21.
- Stillwell, W. H. (1965). *X-15 Research Results With a Selected Bibliography*. NASA. Washington, DC: NTIS.
- Stone, D. A. (2002). *Policy Paradox: The Art of Political Decision Making*. New York, NY: Norton.
- Sung, H. H., Morrison, A. M., & O'Leary, J. T. (1996). Definitions of Adventure Travel: Conceptual Framework for Empirical Application from the Providers' Perspective. *Asia Pacific Journal of Tourism Research* , 1 (2), 47-68.
- Sung, H. H. (2000). *An Analysis of the Adventure Travel Market: From Conceptual Development to Market Segmentation*. Purdue University. West Lafayette, IN: Unpublished doctoral thesis.
- Sung, H. H. (2001). Adventure Travelers: Who Are They and What They Do on Their Adventure Vacations? *Trends 2000: Shaping the Future*. Lansing, MI: Trends.
- Swarbrooke, J. (2003). *Adventure Tourism: The new frontier*. Oxford: Butterworth-Heinemann.
- Thornton, E. A. (1996). *Thermal Structures for Aerospace Applications*. Reston, VA: American Institute of Aeronautics and Astronautics.

- Turner, B. A. (1994). Causes of Disaster: Sloppy Management. *British Journal of Management* , 5 (3), 215.
- Turner, M. J. (2005). *Rocket and Spacecraft Propulsion: Principles, Practice and New Developments*. Berlin, Germany: Springer-Praxis.
- United States. (2007, January 1). Title 49, Chapter 8, Part 830: Notification and Reporting of Aircraft Accidents or Incidents. *Code of Federal Regulations* , 7 , 187. Washington, DC: US Government Printing Office.
- US Congress. (1984, October 30). Public Law 98-575: Commercial Space Launch Act of 1984. Washington, DC: US Government Printing Office.
- US Congress. (1988a, October 30). Public Law 105-309: Technology Administration Act of 1988. *US Code* . Washington, DC: US Government Printing Office.
- US Congress. (1988b, November 15). Public Law 100-657: Commercial Space Launch Act Amendments of 1988. US Government Printing Office.
- US Congress. (1998, October 28). Public Law 105-303: Commercial Space Act of 1998. Washington, DC: US Government Printing Office.
- US Congress. (2003). *The Commercial Space Transportation Act of 2003*. United States Congress, Committee on Commerce, Science, and Transportation. Washington, DC: US Government Printing Office.
- US Congress. (2004, December 24). Public Law 108-492: Commercial Space Launch Amendments Act of 2004. Washington, DC: US Government Printing Office.
- US Congress. (2006, December 15). 49 USC, Subtitle IX, Section 70101–70119. *United States Code* . Washington, DC: US Government Printing Office.
- Vaughan, D. (1996). *The Challenger Launch Decision Risky Technology, Culture, and Deviance at NASA*. Chicago, IL: University of Chicago Press.
- Vedda, J. A. (2006). *Study of the Liability Risk-Sharing Regime in the United States for Commercial Space Transportation Space Launch Operations*. El Segundo, CA: The Aerospace Corporation.
- Viscusi, W. K., & Zeckhauser, R. J. (1990). Risk Within Reason. *Science, New Series* , 248 (4955), 559-564.
- Walker, M. (2007). Suborbital Space Tourism Flights: An Overview of Some Regulatory Issues at the Interface of Air and Space Law. *Journal of Space Law* , 33 (2), 375-404.
- Wertz, J. R., & Larson, W. J. (1999). *Space Mission Analysis and Design*. Torrance, CA: Microcosm.
- White, L. (1961). Eilmer of Malmesbury, an Eleventh Century Aviator: A Case Study of Technological Innovation, Its Context and Tradition. *Technology and Culture* , 2 (2), 97-111.
- Whitnah, D. R. (1966). *Safer Skyways: Federal Control of Aviation, 1926-1966*. Ames, Iowa: The Iowa State University Press.
- Wie, B. (1998). *Space Vehicle Dynamics and Control*. Reston, VA: American Institute of Aeronautics and Astronautics.
- Wilks, J., & Page, S. (2003). *Managing Tourist Health and Safety in the New Millennium*. Amsterdam, The Netherlands: Pergamon.
- Wolf, C. (1978). *A Theory of "Non-Market Failure": Framework For Implementation Analysis*. Santa Monica, CA: The Rand Corporation.
- Zuckerman, M. (1979). *Sensation Seeking: Beyond the Optimal Level of Arousal*. L. Erlbaum.

BIOGRAPHY

Michael Elliot Leybovich

April 3, 1983

Born at the Barnes Jewish Hospital in St. Louis, MO to Izzy and Larissa Leybovich

June 2001

Graduated from Irvine High School in Irvine, CA

August 2001 – May 2005

Attended college at the University of California, Berkeley

Worked as research assistant at Space Sciences Lab

Served as President of the Associated Students of the University of California

May 2005

B.S. Engineering Physics from the University of California, Berkeley

June 2005 – August 2006

Worked as wilderness guide in Stanislaus National Forest at Lair of the Golden Bear

Worked at The Aerospace Corporation in the Economic and Market Analysis Center as a

Member of the Technical Staff

Traveled around the world for half of a year, visiting over 30 countries

August 2006

Enrolled at the Massachusetts Institute of Technology to pursue M.S. in both the

Technology & Policy Program and the Department of Aeronautics and Astronautics

August 2006 – December 2008

Worked as Research Assistant in Laboratory for Energy and the Environment on
alternative fuels for air transportation

Served as Graduate Student Representative on Corporation Joint Advisory Committee

Worked as Research Assistant in Space, Policy, and Society research group on
government regulation and oversight of commercial human spaceflight

Researched British industrial policy in the automotive and aviation sectors at Judge
Business School at Cambridge University

Co-authored “Analysis of Human Space Flight Safety” with The Aerospace Corporation,
George Washington University, and MIT for presentation to FAA and Congress

Inducted into Sigma Xi Scientific Research Society

APPENDICES

Appendix A: Acronyms 94
Appendix B: COUHES documentation 95
Appendix C: Tag cloud..... 96

Appendix A: Acronyms

<u>Acronym</u>	<u>Phrase or name</u>
ADCS	Attitude Determination and Control System
C&DH	Command and Data Handling
CAA	Civil Aeronautics Administration
CAB	Civil Aeronautics Board
CHS	Commercial Human Spaceflight
CS	Commercial Spaceflight
CSLA	Commercial Space Launch Act
CSLAA	Commercial Space Launch Amendments Act
DOC	Department of Commerce
DOD	Department of Defense
DOT	Department of Transportation
ECLSS	Environmental Control and Life Support System
ELV	Expendable Launch Vehicle
FAA	Federal Aviation Administration, né Federal Aviation Agency
FAA/AST	Federal Aviation Administration Office of Commercial Space Transportation
FAR	Federal Aviation Regulations
GNC	Guidance, Navigation, and Control
HS	Human Spaceflight
HTHL	Horizontal Takeoff, Horizontal Landing
ICC	Interstate Commerce Commission
NACA	National Advisory Committee for Aeronautics
NASA	National Aeronautics and Space Administration
NRC	National Research Council
OSC	Office of Space Commercialization
RLV	Reusable Launch Vehicle
SFP	Spaceflight Participant
SR	Self Regulation
TCS	Thermal Control System
TPS	Thermal Protection System
TT&C	Telemetry, Tracking, and Command
US	United States
US CPSC	United States Consumer Product Safety Commission
USPA	United States Parachute Association
USSR	Union of Soviet Socialist Republics
VTHL	Vertical Takeoff, Horizontal Landing
VTVL	Vertical Takeoff, Vertical Landing

Appendix B: COUHES documentation

CONSENT TO PARTICIPATE IN INTERVIEW

A Technoregulatory Analysis of Government Regulation and Oversight in the United States for the Protection of Passenger Safety in Commercial Human Spaceflight

You have been asked to participate in a research study conducted by Misha Leybovich from Aerospace Engineering and the Technology & Policy Program at the Massachusetts Institute of Technology (M.I.T.). The purpose of the study is to study government regulation of commercial human spaceflight by comparing that nascent industry with other, more established, high-risk recreational activities. The results of this study will be included in Misha Leybovich's Masters thesis. You were selected as a possible participant in this study because you are a leader in one of the industries of interest for the study. You should read the information below, and ask questions about anything you do not understand, before deciding whether or not to participate.

- This interview is voluntary. You have the right not to answer any question, and to stop the interview at any time or for any reason. We expect that the interview will take about 30 minutes to 1 hour.
- You will not be compensated for this interview.
- Unless you give us permission to use your name, title, and / or quote you in any publications that may result from this research, the information you tell us will be confidential.
- We would like to record this interview on audio cassette so that we can use it for reference while proceeding with this study. We will not record this interview without your permission. If you do grant permission for this conversation to be recorded on cassette, you have the right to revoke recording permission and/or end the interview at any time.

This project will be completed by September 4, 2008. All interview recordings will be stored in a secure work space until 1 year after that date. The tapes will then be destroyed.

I understand the procedures described above. My questions have been answered to my satisfaction, and I agree to participate in this study. I have been given a copy of this form.

(Please check all that apply)

- I give permission for this interview to be recorded on audio cassette.
- I give permission for the following information to be included in publications resulting from this study:
- my name my title direct quotes from this interview

Name of Subject: _____

Signature of Subject: _____ Date: _____

Signature of Investigator: _____ Date: _____

Please contact Misha Leybovich (mishaley@mit.edu, 617-324-2194) with any questions or concerns.

If you feel you have been treated unfairly, or you have questions regarding your rights as a research subject, you may contact the Chairman of the Committee on the Use of Humans as Experimental Subjects, M.I.T., Room E25-143b, 77 Massachusetts Ave, Cambridge, MA 02139, phone 1-617-253-6787.

Appendix C: Tag cloud



from <http://www.tagcrowd.com>