

# Analysis of the Product Development Process for Geographically Distant Teams in Vehicle Tophat Design Phases

by

**Antonio Del Puerto Valdez**

B.S. Mechanical and Electrical Engineering (2001)  
Instituto Tecnológico y de Estudios Superiores de Monterrey

Submitted to the System Design and Management Program  
in Partial Fulfillment of the Requirements for the Degree of

**Master of Science in Engineering and Management**

**ARCHIVES**

at the

Massachusetts Institute of Technology

February 2010

© 2010 Antonio Del Puerto Valdez  
All rights reserved

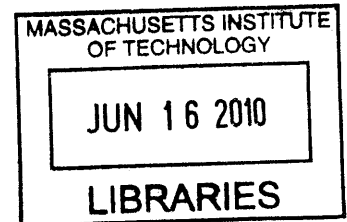

The author hereby grants to MIT permission to reproduce and to distribute publicly paper and electronic copies of this thesis document in whole or in part in any medium now known or hereafter created.

Signature of Author \_\_\_\_\_

Antonio Del Puerto Valdez  
System Design and Management Program  
February 2010

Certified by \_\_\_\_\_

Christopher L. Magee  
Thesis Supervisor  
Professor of the Practice of Mechanical Engineering and Engineering Systems  
Co-Director, Engineering Design and Advanced Manufacturing (EDAM), MIT-Portugal Program

Certified by \_\_\_\_\_

Patrick Hale  
Director  
System Design & Management Program

THIS PAGE IS INTENTIONALLY LEFT BLANK

*To my mother.*

*A paragon of courage and hard work*

*Muchas gracias.*

THIS PAGE IS INTENTIONALLY LEFT BLANK



# **Analysis of the Product Development Process for Geographically Distant Teams in Vehicle Tophat Design Phases**

by

**Antonio Del Puerto Valdez**

Submitted to the System Design and Management Program  
in Partial Fulfillment of the Requirements for the Degree of

**Master of Science in Engineering and Management**

## **ABSTRACT**

The current global economic recession is putting pressure to increase model variation on the carmakers, while at the same time leveraging highly efficient and proven platforms and product development assets globally is becoming critical. In order to be competitive, OEMs would prefer to use their low cost country branches that have competitive engineering capabilities to reduce costs of development. It is then important that the organizations in these countries have a well defined process and the expertise to effectively interact with the OEM headquarters where the executive decision makers reside; and with the Design Studio, the entity in charge of designing the appearance of the reverse-engineered components. This thesis develops such a process from study of the necessary requirements, construction of a DSM and consideration of past attempts at programs where engineering and studio design were not co-located.

The process to engineer a vehicle exterior and interior is called the feasibility process. In the OEM under investigation, this method is conducted at a component level to leverage the detailed expertise of its Engineering department and suppliers. This is done after several styling options are studied and research through customer clinics to narrow the number of designs that are made feasible to Engineering to normally one. This approach leads to several iterations when each component changes and affects others or the overall system performance. In order to integrate all feasibility changes and achieve styling intent, Engineering must communicate the constraints and Design Studio must understand them and re-style the appearance to accomplish the functional performance.

Upon analysis of the OEM engineered functional teams and the components that strongly affect appearance the key sub-system expertise is defined for low cost countries to develop knowledge on them. In addition, from construction of a DSM, we were able to clearly identify the Design Studio intensive process loop and the concurrent engineering loop within the product development process. Moreover, the information transfer interfaces were clearly recognized. These interfaces were reviewed in former distant interaction projects and showed additional workload in the preparation of information prior to the communication process, while in co-located projects, this happens in real time while and where communication takes place.

Nevertheless, awareness of the component changes helps Design Engineers to be aware of the system implication of the change and reduce the amount of iterations by addressing them prior to Engineering cut-off, to allow the Design Studio to focus only on the appearance of the integrated system. In the same way, Design Engineering helps the Design Studio to assess additional surface changes to achieve surface

quality before surfaces are released to Engineering. Therefore Design Engineering must be co-located at both ends: where Engineering is preparing functional information and where the Studio prepares styling information. The resulting spoke and hub model, establishes the Design Engineer as the single point of contact for daily interaction. Conference calls and virtual tools have been very useful for the day-to-day communication, however scheduled and periodical face-to-face meetings between distant the Design Engineering teams has been proven to provide good results to enhance team identity, convey priorities and clarify difficult issues.

This approach has been used formerly in several past programs, yet all of them have been conducted with a US based Design Studio and an overseas Engineering team. The product development process used in these projects was not the one normally used by the US OEM but that of its Japanese Partner Company, which is more disciplined in terms of surface changes. This forces Engineering to front-load the process to address not only component but also system level problems. Similarly, late styling changes are kept to a minimum to avoid unplanned iterations of component, relational and pure design feasibility.

One important enabler to reduce the required interaction and thus eliminate lengthy and noisy communication is to re-use legacy program information by leveraging platform knowledge. Since platforms are initially launched designing a base tophat, it is important to update such information after the design is verified and re-use it as well as those resources that generated and that understand the system's performance. This approach will improve platform level quality and time to provide feasibility for every platform's tophat.

Models are important tools for the Studio to understand the overall integration of surfaces and the clarification of the idea "is it really what I think it is?" by allowing the designers to understand proportion and shape in a physical model as well as the real integration of surfaces continuity through daylight revisions prior to tooling kick-off. Additionally it is an important aid to convey a lot of information implicit in the surfaces to the top management of the OEM showing the status of the latest feasible design for which cost and quality targets are recognized. Nonetheless, models are also important for engineers to understand part transitions, radii grain execution and several other details that may not impact functionality but are essential for leadership in craftsmanship. This is why engineers must have access to a detailed model that accurately represents Design Studio's vision on the execution of such details.

Thesis Supervisor: Christopher L. Magee

Title: Professor of the Practice of Mechanical Engineering and Engineering Systems,  
Co-Director Engineering Design and Advanced Manufacturing (EDAM)  
MIT-Portugal Program

## Acknowledgements

Attending graduate school had been a central aspiration ever since I was awarded the immense opportunity of having a college education. Nevertheless, doing so at the Massachusetts Institute of Technology was beyond any thought. As I see this wonderful journey come to an end, I want to convey my gratitude to those who made this not only possible, but also wonderful.

Before all others, I would like to express my deepest gratitude and love to *my mother*, for being a model of dedication and courage. Her sacrifices have taken me far in life and her lessons will keep helping me to reach higher.

Now, I would like to manifest a great deal of appreciation to all who I consider fundamental for this life achievement to come true:

*Marcos Pérez* for his passion, vision and inspiring leadership that made my Systems Design and Management dream become a reality.

*Juan Pablo Jiménez* for his time, patience, enthusiasm, wise advice and valuable contribution to this thesis and to my professional development. I could not have asked for better mentoring.

*Christopher Magee* for sharing his broad experience in industry and academy to guide me through this new process of writing a thesis. His prompt and thorough feedback were crucial to bring this work to completion.

*José Quintanar* for his candid insights and for believing in me to handle difficult tasks since the very first day I worked with him. Most importantly, for helping me understand the value of being accountable.

*Flavio González, Raúl Chávez, Alejandro Ayala, Enrique Delannoy, Roberto Villegas* and the Mexican PD Management team for their encouragement and support before and during this program despite their challenging workloads. Their diverse opinions have boosted my understanding of the difficulties of managing people development.

*Gary Mullen* and *Andy Thomas* for their patience and full support to my attendance to the SDM program. Also, for facilitating a learning environment from which I benefited greatly to become a better engineer.

*Patrick Hale, Jon Griffith, Jack Grace, other MIT Faculty and SDM Staff* for all the prompt support throughout the program and particularly for their kindness during my time in Boston.

*Adrián Díaz* for sharing his experience at the SDM program and at work. His friendship, guidance and positive outlook have been invaluable.

*Marcia Azpeitia* for standing by my side all through this endeavor as a classmate, co-worker and friend.

*Raul Pinillos and David Díaz* for the fascinating discussions.

*Adrián Aguirre, Takahiro Endo, and José Antonio Almazán*, for always being available for advise being pioneers of the SDM program. They not only led the way for future generations but also set the bar up high.

*Sooraj and Asia Prasannan, Jorge Amador, Ellen Czaika, Leigh Gautreau, Charbel Rizk, Kenneth Liu and Eumir Reyes* for their friendship. They have been “instrumental” in making the SDM program one of the most enjoyable experiences in my life.

Finally I want to express my utmost respect and admiration to the entire SDM'08 cohort. I learnt from every one of them in each Opportunity Set and business trip. Each of you has left an indelible mark in my soul. I feel grateful for having had the opportunity to surround myself with such a group of enthusiastic and inspiring people.

THANK YOU

# Table of Contents

|  |           |
|--|-----------|
| ABSTRACT.....  | 5         |
| Acknowledgements.....  | 7         |
| Table of Contents.....   | 9         |
| List of Figures.....   | 11        |
| List of Tables.....  | 12        |
| List of acronyms.....  | 13        |
| <b>Chapter 1.....</b>  | <b>17</b> |
| INTRODUCTION.....  | 17        |
| 1.1 Motivation.....  | 17        |
| 1.2 Value Proposition and PDP Optimization.....                                | 19        |
| 1.3 Thesis Objective.....  | 22        |
| 1.4 Hypothesis.....  | 23        |
| 1.5 Data Collection Methods and Sources.....                                   | 23        |
| 1.6 Thesis Structure.....  | 24        |
| <b>Chapter 2.....</b>  | <b>27</b> |
| Tophat Development.....  | 27        |
| 2.1 Vehicle Architecture: Platform + Tophat.....                               | 27        |
| 2.2 Studio Designed Components engineering process in vehicle development..... | 30        |
| 2.3 PD Organization in NA OEM.....   | 32        |
| 2.4 Aesthetic design.....  | 33        |
| 2.5 Early stages.....  | 34        |
| 2.6 Feasibility process.....   | 36        |
| 2.7 Design Studio Cultural Insights.....                                       | 48        |
| 2.8 The Design Engineer Role.....  | 51        |
| <b>Chapter 3.....</b>  | <b>53</b> |
| Issues with current tophat development process.....                            | 53        |
| 3.1 Approach to concurrent engineering during feasibility process.....         | 53        |
| 3.2 Standardization of platform feasibility information.....                   | 55        |
| 3.3 Inter-subsidiary communication noise.....                                  | 58        |

|   |            |
|---|------------|
| 3.4 Cultural differences and expectations .....   | 59         |
| <b>Chapter 4</b> .....  | <b>61</b>  |
| DSM of a Tophat development project .....   | 61         |
| 4.1 Introduction to the DSM.....  | 61         |
| 4.2 Task based DSM as Project Management tool .....   | 64         |
| 4.3 Modularity in the PDP.....  | 65         |
| 4.4 DSM construction .....  | 66         |
| 4.5 Analysis of the DSM.....  | 66         |
| 4.6 DSM Considerations.....   | 74         |
| <b>Chapter 5</b> .....  | <b>78</b>  |
| Lessons learnt from case studies .....  | 78         |
| 5.1 Former distance interaction between US OEM and other subsidiaries.....                    | 78         |
| 5.2 Analysis of lessons learnt.....   | 87         |
| <b>Chapter 6</b> .....  | <b>90</b>  |
| Conclusions .....   | 90         |
| <b>Appendix</b> .....   | <b>98</b>  |
| Appendix A: Examples of platforms and tophats from different OEMs.....                        | 98         |
| Platform and Tophats of GM .....  | 98         |
| Platform and Tophats of GM (continued) .....  | 99         |
| Platform and Tophats of Ford.....   | 100        |
| Platform and Tophats of Ford (continued) .....  | 101        |
| Platform and Tophats of Ford (continued) .....  | 102        |
| Platform and Tophats of Chrysler.....   | 103        |
| Platform and Tophats of Chrysler (continued).....   | 104        |
| Platform and Tophats of Chrysler (continued).....   | 105        |
| Platform and Tophats of Volkswagen.....   | 106        |
| Appendix B: Studio Designed Tophat commodities.....   | 107        |
| Appendix C: Work Breakdown Structure (WBS) of Tophat development project.....                 | 111        |
| Appendix D: Raw and Partitioned Design Structure Matrices (DSM) of the PDP Design Phase ..... | 113        |
| <b>Bibliography</b> .....   | <b>119</b> |

## List of Figures

|   |    |
|---|----|
| Figure 1 Mercedes-Benz CLK by Giorgio Armani (left) (Daimler-Chrysler) Advanced Design Studio in Como (Italy) (right) (Mercedes-Benz, 2008) .....                               | 20 |
| Figure 2 General Motors' electric-vehicle platform (Bullis, 2007) .....   | 29 |
| Figure 3 Mazda 3 (left), Volvo C40 (center) and Ford Focus (right) 2010MY built from shared compact platform.....   | 29 |
| Figure 4 Functional staffing scheme based on component level expertise .....  | 33 |
| Figure 5 1:4 scale half mirrored model at GM (left) and Holden (right) from Car Design Online (Clay Modelling).....   | 34 |
| Figure 6 Full scale clay model of BMW 7-series (Vanderwerp, 2008) .....   | 35 |
| Figure 7 Surface change from different information inputs for door trim, and instrument panel.....  | 39 |
| Figure 8 Rear Quarter Trim feasibility study (OEM under study) .....  | 41 |
| Figure 9 Feasibility Section generic content (OEM under study) .....  | 42 |
| Figure 10 Chris Bangle (BMW Chief Designer) in a Studio walk around (Car Body Design).....  | 43 |
| Figure 11 Surfaces release transmittal designed in CAS Alias (left). Rendered CAS surface in Alias (Body Car Design, 2005) (Body Car Design, 2005) (Body Car Design, 2005)..... | 44 |
| Figure 12 Clay Vs. CAS development time according to BMW (Thomke, BMW AG: The Digital Car Project, 2001) .....  | 45 |
| Figure 13 Comparison of design complexity between BMW and an entry level vehicle .....  | 46 |
| Figure 14 Performance of CAS and Clay Hybrid method.....  | 48 |
| Figure 15 Ponit-based CE in current feasibility process at NA OEM (Ward, 1995).....   | 54 |
| Figure 16 Set-based feasibility process at Toyota (Sobek II, Ward, & Liker, 1999) .....   | 55 |
| Figure 17 Location of throttle body design knowledge in Ford Motor Company (Dong, 2002) .....   | 56 |
| Figure 18 Occupant position is carried over different tophats (OEM under study).....  | 57 |
| Figure 19 Internal combustion engine object based DSM (Smaling & de Weck, 2007) .....   | 62 |
| Figure 20 Incidence Matrices from De Weck & Haberfellner .....  | 63 |
| Figure 21 GM Engine Development team (De Weck O. , 2008).....   | 63 |
| Figure 22 Information flow criteria for task based DSM .....  | 64 |
| Figure 23 Possible sequences of tasks in a project.....   | 65 |
| Figure 24 Partitioned DSM with identified loops in the NA OEM PDP .....   | 67 |
| Figure 25 Upper information flow of interface DSM.....  | 71 |
| Figure 26 Lower information flow of interface DSM.....  | 73 |

## List of Tables

|   |    |
|---|----|
| Table 1 Functional sub-systems of Studio Designed Components and number of components .....   | 32 |
| Table 2 Activities and stakeholders required for PD ongoing process (not program specific) loop .....   | 69 |
| Table 3 Stakeholders involved in the concurrent engineering loop required to accomplish Tophat engineering capability .....                       | 70 |
| Table 4 Upper information flow / interfaces .....   | 72 |
| Table 5 Lower information flow / interfaces .....   | 73 |
| Table 6 Former programs with distant interaction between Design Studio and Body Engineering within the organizations of the OEM under study ..... | 78 |



## List of acronyms

| ACRONYM / ABBREVIATION | DESCRIPTION                             |
|------------------------|---|
| BE                     | Body Engineering                        |
| CAM                    | Computer Aided Manufacturing            |
| CAS                    | Computer Aided Styling                  |
| CE                     | Concurrent Engineering                  |
| CNC                    | Computer Numerical Control              |
| DE                     | Design Engineer                         |
| DNA                    | Brand Identity                          |
| DS                     | Design Studio                           |
| DSM                    | Design Structure Matrix                 |
| ECO                    | Engineering Cut-off                     |
| EMM                    | Electronic Math Modeling                |
| EU OEM                 | European Subsidiary of US OEM           |
| FC                     | Feasibility Checkpoint                  |
| FP                     | Feasibility Process                     |
| FSS                    | Full Services Supplier                  |
| GPDP                   | Global Product Development Process      |
| JPC                    | Japanese Partner Company                |
| KPC                    | Korean Partner Company                  |
| LCC                    | Low Cost Country                        |
| MEX OEM                | Mexican Subsidiary of US OEM            |
| NA OEM                 | US OEM                                  |
| OEM                    | Original Equipment Manufacturers        |
| PD                     | Product Development                     |
| PDP                    | Product Development Process             |
| SDC's                  | Studio Designed Components              |
| SFEC's                 | Straight-Forward Engineered Commodities |
| SUV                    | Sport Utility Vehicle                   |
| VOC                    | Voice of the customer                   |
| WBS                    | Work Breakdown Structure                |
| WIP                    | Work in progress                        |

THIS PAGE IS INTENTIONALLY LEFT BLANK

*What is it about the automobile that gives it such a special place in our hearts compared with all those other products that form our everyday life?...the greatest difference between the car and most of those other products with which we surround ourselves is that it does not remain static: it is not inanimate – it displays animal-like behavior.*

**Peter Horbury**

Executive Director of Design. Premier Automotive Group, Ford Motor Company

THIS PAGE IS INTENTIONALLY LEFT BLANK

# Chapter 1

## INTRODUCTION

### 1.1 Motivation

According to Alex Trotman, former CEO of Ford Motor Company, since the mid-1990s, customers demanded more choices at lower costs, leading to a rise in the second-hand and almost new cars purchases. This is a reason why OEMs accelerated the new model development and enhanced model variation (Thomke, BMW AG: The Digital Car Project, 2001).

Building more model variants results in the need to reduce the fixed costs to develop them, since there are fewer units more differentiated in which spread the investment. In addition, recent economic turmoil has forced PD organizations to become more competitive to bring products to market by leveraging their global assets to avoid re-engineering. In 2006 Allan Mulally, Ford Motor Company CEO, declared as a part of a drastic turnaround plan:

“We’re also speeding up our product development time and improving time to market between 30 and 50 percent by the end of 2008. And in 2009 and beyond, the product onslaught accelerates even further... We will leverage our global product capability like never before, including new small cars... We’ve examined our entire cycle plan, and we’ve accelerated work on future products... In line with this new reality, we will resize our business in North America. That includes reducing our total annual operating costs by about \$5 billion by the end of 2008. As part of these cuts, we will reduce

our salary related costs by about a third, or about 14,000 equivalent salaried positions.” (Larkin, 2006)

Under these circumstances, finding the appropriate value flow to depict a technological strategy that will allow OEMs to be more profitable in the future plays a major role. By bringing much of the engineering in-house, they will be able to eliminate uncompetitive mark-ups charged by full service suppliers in commodities that can be more easily engineered today than before. Also, developing countries have acquired important engineering capabilities that can help improve the cost of creating more vehicle variants.

In addition, it is important to note that there is extensive literature to support incremental improvements and technological advances in vehicle performance and manufacturing processes capability. Many research projects have achieved methods to develop better systems to improve product costs and functionality. Particularly in the automotive industry, manufacturing and product development processes have gained the attention as key elements of value delivery.

Unfortunately, much of the systems engineering literature is only focused on functionality that should emerge from form. Also, there is plenty of information on how to make attractive vehicles, but there is little research on how to accomplish both from an integrated perspective.

Nevertheless a car is much more than a practical object to go from point A to point B. A car is an emotional product. No matter how powerful or fuel efficient the engine is, or how complex and optimized the supply chain was developed, if the product does not look fine, it won't be a success. The process of taking a simple sketch from the drawing board into the assembly plant is probably the most challenging task in terms of communication and coordination for any given vehicle program. This activity demands numerous stakeholders and requires investing several million dollars.

It is also in this activity that the Engineering team is responsible to determine the variable cost of manufacturing such aesthetic intent and try to make it fit within the cost and functional targets with minimum change in appearance.

Senge (Senge, 1990) suggests how the trend in appearance and quality has been significant for product success. Before German and Japanese OEMs started to sell vehicles in the US, surveys demonstrated that customers cared more for appearance than for quality. As the competition intensified and American customers became more “educated” in the benefits of quality, those foreign OEMs increased their market share from 0 to 38 percent by 1986.

However, as quality has driven much of current PDP and technological improvements, there is no such a thing as a bad car anymore; most car companies have developed engineering practices capable of delivering the best quality in most segments. Therefore, as this gap has narrowed, the importance of styling has arisen as determinant for product success.

It is commonplace to find that the major functional PD organizations in an automotive OEM are Power train, Chassis, Body and Electrical. For some, Design Studio is normally seen as a minor contributor. For others, it is an area more linked to the soft managerial side of the business, closer to Marketing than to Engineering delivering just a “close idea” of the product appearance. Upon our research, many product development engineers in the industry can support that this functional team is actually involved longer than it is believed and has more power of decision over cost, timing and attributes than any other. As we will see, the Design Studio is as technical as it is artistic and requires applying systems thinking to tackle feasibility and styling problems that arise as more information is available during the Product development process. Therefore it is crucial to detect and strategize the appropriate managerial policies from lessons learnt in different programs. It is particularly interesting when related to the distant interaction, in which hard data is shared between subsidiary organizations and expectations can affect the communication of this kind of information.

## 1.2 Value Proposition and PDP Optimization

As we have previously stated, most of the value related to the appearance of a vehicle is developed in close interaction with stylists, marketers and key corporate decision makers. Upon revision, it is apparent that most of this value creation process occurs in highly developed countries for several reasons:

- 1) Different from most underdeveloped countries, customer purchase decision in these markets is more value driven than cost driven. They are more informed and exigent towards the perceived value of a good looking product.
- 2) The process requires close interaction with breakthrough products, services and cultural trends of target customers. Thus, close interaction with the customer environment favors the inspirational information flow to foster designers' creativity.
- 3) The process requires close coordination between designers and both marketers and key decision makers, who are primarily located within the largest customer clusters and corporate headquarters namely USA, Italy, France, Germany, Japan, Brazil and more recently China.

- 4) Benchmarking and competition are very intense in these large markets, reason why it is important that the designers can quickly react to new breakthrough products from competitors.

This value creation stage that demand such interactions can be understood as *highly strategy intensive*, given the communication that shareholders, decision makers, designers and customers undergo to determine the best options for vehicle appearance.

As an example, Mercedes-Benz established 3 Advanced Design Studios in Irvine (USA), Yokohama (Japan), and Como (Italy), all three with the same objective. “Our goal is to try to predict social trends as far into the future as possible” says Peter Pfeiffer, head of Design at Mercedes-Benz. According to Hans-Harald Hanson, Head of Strategic Design Concepts at Mercedes-Benz, northern Italy is particularly well suited to gage top-quality lifestyle ideas “The Como-Milan-Turin triangle is home to the furniture and fashion industry... Accordingly, high value is placed on traditional craft – making it an ideal environment for the Advanced Design Studio... And there was another significant reason for selecting Como: Italy is one of the biggest markets for sales of “La Mercedes” – as the vehicles are more familiarly known.” As a result of this close interaction of customer, inspiration and trend, fashion designer Giorgio Armani created the exclusive “Mercedes-Benz CLK designo by Giorgio Armani”. (Mercedes-Benz, 2008)



Figure 1 Mercedes-Benz CLK by Giorgio Armani (left) (Daimler-Chrysler) Advanced Design Studio in Como (Italy) (right) (Mercedes-Benz, 2008)



The complementary part for this value proposition resides in the hard and iterative Engineering process, which is in charge of dealing with the details and burdensome interaction of multiple subsystems, issue resolution, targets achievement and in detail design to deliver function. CAD development, CAE analyses, cost tracking, build events and testing, normally carry a lot of engineering hours to complete and some additional amount to re-work to fix discovered problems. This kind of activities can also be defined as *labor intensive*, because despite the fact that they do not involve a large amount of physical labor, they do require a vast amount of manpower relative to the *strategy intensive activities*. There are many factors that can improve the cost of this set of value creation activities, particularly the use of Low Cost Countries (LCC's) with mature technical capabilities.

As a result, the mechanism that automotive OEMs are undertaking to transfer the value of the highly strategy intensive to the highly labor intensive process is applying a standardized work stream to create design construction sections and parametric models, that allow LCC's to develop products based on the company's global knowledge accumulated through the use of design rules, and clear specifications that assure quality and quick delivery. This value proposition had been previously been pursuit in the food industry by McDonald's (Huckman, 2006), which bases its operations strategy in developing tools to produce a large volume of ingredients to accomplish exigent standards as well as innovative easy to use cookware. These enablers allowed McDonald's to lower the manpower costs while sustaining repeatable quality throughout the world.

Blake, Cucuzza and Rishi (Blake, Cucuzza, & Rishi, 2003) report that while competition in the automotive industry develops, each OEM will search for different competitive advantages while at the same time keeping a tight control over costs. They define three critical factors for success in the industry:

Capacity of response to customer. - Understand the changes in the market to create products that fulfill or exceed customer expectations.

Rapid response to the market. - Capability to develop and launch products faster than competitors.

Innovation.- Quickly adoption of technological innovation into the full vehicle system integration.

The value proposition previously introduced is essential to accomplish the cost targets that a faster product turnaround demands. At the same time, the styling attribute is subject to these three critical factors in industry to create a better looking and more differentiated product.

### 1.3 Thesis Objective

The decision making process about any feature in the vehicle appearance is critical before spending millions of dollars in tooling in this high volume good. Key decision makers from all product attribute teams must be aware and agree upon the functional impact of appearance surfaces change; however the ownership of such instruments lies within the boundaries of the Design Studio, who is the entity in charge of generating the value attributable to the vehicle appeal.

One of the main concerns of this value proposition is the information exchange process. Some of the information that is required to engineer a vehicle's variant such as functional content, specification and test descriptions is easily transferred in written documents. However, there is another kind of information that requires a different interaction to be communicated. For example, styling and engineering information are embedded into surfaces and hardware and would normally involve face-to-face interaction between Design Studio and Body Engineering in front of a physical model to describe the needs of each activity.

This study aims to provide an insightful view of the operations inside both an automotive Design Studio and an Engineering department, focusing on the types of information that are handled and the communication interactions. In the same way, focus on the operational communication from the Design Studio to other areas (vehicle attributes, component owners, program management and upper management, among others).

This document should be capable of guiding the strategy of emerging LCC organizations that have the objective of achieving vehicle exterior and interior (normally known as *tophat*<sup>1</sup>) engineering capability in identifying:

- 1) Key activities that are required to develop a tophat using a concurrent engineering (CE) approach.
- 2) Understand the activities that can and should be outside of the LCC subsidiary organization in order to maximize value creation.

Provide recommendations on how to develop successful interfaces to undertake the activities required to deliver a tophat that are outside of the subsidiary organization.

---

<sup>1</sup> For a complete definition for tophat see page 22 of this thesis

## 1.4 Hypothesis

Upon revision of the intended operating system architecture, it is not required to have a Design Studio co-located with the Body Engineering team to effectively and efficiently engineer a tophat. This is because the design and engineering activities have been highly decoupled through the use of information tools and managerial policies that allow the information exchange to be equally effective regardless of the geographic location. Current work stream within the OEM allows the appropriate interaction between Studio and Engineering organizations to exchange product development information. Such mechanisms can be synchronous or asynchronous depending on the nature of each design problem that has to be solved, the timing for decision making and issues resolution, and the geographic constraints of the key stakeholders responsible for the vehicle attributes and project management.

However, after research and analysis, it is possible that the coupled nature of the development process will drive the need of having some on-site activities that would lie within the boundaries of the Design Studio that will allow clear communication of the engineering and styling requirements with the key stakeholders for each design problem that has to be solved. Especially when the product development operating system must be robust enough to quickly respond to the undiscovered rework yield from the Engineering Disciplines practice, Design Reviews, and validation processes during the development stages; all prior to tooling kick-off and formal product verification (physical testing) procedures.

Such interaction can be successfully achieved by analyzing the current product development process to understand the information exchange needs required at different program milestones. From there, some suggested architectural instruments are derived based on specific information needs and real case studies of past distance programs worked between USA and Japan, USA and Germany, and more recently Mexico and USA.

## 1.5 Data Collection Methods and Sources

Extensive literature research will be conducted to provide clear understanding of general industry accepted methods used to design and engineer vehicle tophats. In the same way to explain contemporary trends in communication and recommended managerial strategies to improve collaboration.

Nonetheless, the level of interaction required to deliver the value proposition cannot be solved by means of pure literature research of good practices. Therefore, an empirical study will be conducted

through interviews with actual team members who have experience in distant interactions within an American OEM. This research includes interviews with Design Studio Engineers and Designers, Product Development Engineers, Chief Engineers and Program Managers during current work assignment in the American OEM. After acquiring key stakeholder insights and appropriate literature research, a Design Structure Matrix will consolidate and define Concurrent Engineering activities that require high on-site interaction. Also, this method will allow the identification of informational supplier / customer interactions that do not require geographical proximity to happen.

In addition to the former external sources, the author of this work was provided with the opportunity of participating in the development of two distance programs as well as several locally designed programs, as a team leader in charge of developing vehicle cockpit components, in order to provide the insights of the Studio/Engineering interaction and the issues of this relationship when they are geographically separated.

## 1.6 Thesis Structure

### *Product Development Process (PDP) description*

It is important to investigate and obtain a thorough understanding of the PDP and the feasibility process. In order to capture the information that must be created and communicated at different stages of the project.

### *Define the detailed Work Breakdown Structure (WBS) of the tasks requires to bring tophat systems from concept to verification*

A field study will be conducted through a real product design project to define all tasks performed by the engineering activity to achieve design maturity at different milestones, as well as to map the information flow and dependencies that underlie throughout the design stages.

### *Create an optimized Design Structure Matrix (DSM)*

After defining the information flow dependencies, the DSM will highlight the metatasks of concurrent engineering that will drive high level of interaction with its process owners. This will aid in understanding the communication needs at different stages and help to identify the best solutions for each interaction.

After identifying the key mechanisms for information exchange, it is important to research management practices for on-going knowledge transfer based on communication types and interactions. This analysis will take into consideration the capabilities available in an emerging organization growth strategy versus the demand coming from specific activities that are outside of the organization systemic boundary. The main outcome from this work, should define feasible organization processes that can effectively engineer vehicle's exterior and interior components while working from the distance with key stakeholders.

THIS PAGE IS INTENTIONALLY LEFT BLANK

# Chapter 2

## Tophat Development

### 2.1 Vehicle Architecture: Platform + Tophat

From a systems engineering perspective, the product development process starts with the problem statement and the development of system level requirements, which are cascaded down into sub-systems and components. The OEM under study has a mature systems engineering PDP, in which the core functional teams have already developed such requirements to be used across all vehicle lines.

According to Dong (Dong, 2002) these are classified as follow:

Functional requirements. - Aimed to define the function the vehicle or its subsystems deliver. For example: The cup holders must be able to support all commercial cups available (i.e. McDonald's, Starbucks, etc.)

Performance requirements. - Aimed to describe the level or intervals of function that the vehicle or its subsystems deliver. For example: The airbag system must deploy in X seconds.

This enables the tophat development team to start with the zigzagging process proposed by Axiomatic Design to accomplish function and performance.

The complete set of functions that a component is meant to provide should contribute to achieve sub-system level goals and consequently vehicle level attributes regardless of the systemic interaction among components. In this sense, a full vehicle assembly can consist of as many as

30,000 components, from hood stampings to screws to carpet. However, an automobile can be thought as having two major sub-systems: the platform and the tophat.

In order to reduce the product development time and benefit from economies of scale, OEMs try to better leverage those components that require high cost of development. Those which generally involve new or unique and expensive technology, and the basic functionality and thus the basic reliability and driving performance. They are then the primary source of vehicle quality and drive most of the critical characteristics for customer value. These components normally form what is called the platform.

Another important characteristic of these commodities is that they are hardly differentiated by the customer among derivatives.

According to Morgan and Liker (Morgan & Liker, 2006), the generally accepted platform components are: the power pack (engine and transmission); front, center pan, and rear end structures, front and rear axles and suspensions; frames and sub-frames; brake and electrical systems; bumper beams; and fuel tank. Once an OEM proves a platform, it can be slightly adapted to fit several tophats. Below is an example of EV platform used by GM to build the Chevy Volt. In the configuration shown here, there is a large battery pack down the center of the vehicle and a generator at the front of the car.



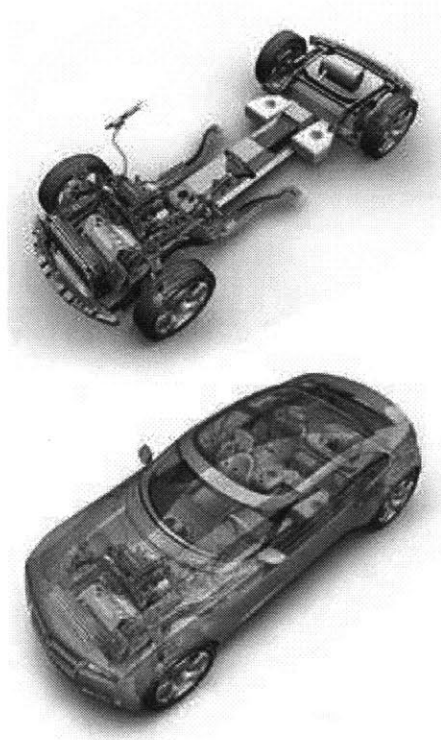

Figure 2 General Motors' electric-vehicle platform (Bullis, 2007)

Similarly, a tophat is made with all other components that are intended to provide differentiation from other products built from the same platform. They are customized to address a specific market, brand and nameplate, but still leveraging mechanical under bodies. Those that the customer has direct physical contact from the showroom to the everyday operation. From new models of the same nameplate to different nameplates that share the common understructure, tophats are normally understood as all new, single model, single series vehicle development programs that are built upon a validated legacy platform and thus a previous tophat.



Figure 3 Mazda 3 (left), Volvo C40 (center) and Ford Focus (right) 2010MY built from shared compact platform.

Tophats are formed by all the exterior sheet metal, interior trim, seating, etc. Examples of different tophats built from common platforms at GM, Ford, Chrysler, Toyota and VW are presented in Appendix A.

## 2.2 Studio Designed Components engineering process in vehicle development

A wire harness is a component relatively unconstrained by form. Although many times the real estate in which it has to fit and attach is limited, the solution to those constraints will ultimately define its final form. This is a more formal and conventional approach in which most engineers were trained, where the system, sub-system and component form is an output of the engineering process.

Conversely, a piece of door trim of a car has its desired form already set upfront by a styling team. As we will further review, the way this form is constrained by the Design Studio (DS) team is through the surface released during the styling process and after initial concept development. In this sense, these surfaces can be seen as another physical feature of the part such as clips, ribs or hooks. Nevertheless the functionality of most of these parts consists in achieving an attractive image. There are some commodities that have additional primary functions such as:

- tail lamps that provide communication with other drivers
- sheet metal, instrument panel and door trim's substrates that provide structure for additional ornamentation, restraints or electronics
- the seats cushion that provide comfort and transfer the load the seat structure during different operational events
- the front grille that must provide enough air flow to the engine fluid and transmission oil coolers.

Given that most Design Studio engineered commodities must provide additional functions and perform such functions competitively, they must undergo what Mengoni et. al. (Mengoni & al., 2007) define as reverse engineering of appealing products.

Mengoni refers to such components as those whose primary function is achieving an engaging image, while at the same time, accomplish specific functions that the customer value and also contribute systemically to deliver the entire product attributes. In the context of this thesis, we will refer to Mengoni's reverse-engineered components as Studio Designed Components (SDC).

On the one hand, all product's attributes such as aerodynamic performance, weight, safety and even reliability and robustness are also an outcome of the form factor of a product. On the other hand,

OEMs focus their policy efforts towards having beautiful “eye-catchers” that convey design language. This represents a contradiction with the straightforward engineering approach in which form is an output of function. For these products and components, form is an input and function has to be accomplished with minimum impact on approved form.

OEMs’ upper management have historically challenged engineering teams to deliver styling intent that has been intensively reviewed by designers and executives, that follows an acclaimed concept in motor shows and that has been well received in marketing clinics. So far, this is the only mechanism that OEMs have to deal with the uncertainty of rapid style trends and specific customer preferences. This situation has always posed a major conflict to understand the right approach to engineer a good looking product. Engineering teams will always push for performance and cost, while styling teams are concerned with keeping their design untouched.

Consequently, the ability to successfully engineer Studio Designed Components is key for automakers, as they are the building blocks of the tophat. A complete list of all SDC's is included in Appendix B, but can be generally classified in the following sub-systems:

| <b>Sub-system</b>      | <b>Number of SDC's</b> |
|------------------------|------------------------|
| Instrument Panel       | 42                     |
| Console                | 39                     |
| Exterior Ornamentation | 38                     |
| Hard Trim              | 36                     |
| Electrical             | 36                     |
| Seats                  | 27                     |
| Door Trim              | 20                     |
| Sheet Metal            | 18                     |
| Headliner              | 14                     |
| Fascias                | 14                     |
| Lighting               | 13                     |
| Steering wheel         | 10                     |
| Closures               | 9                      |
| Glass                  | 7                      |
| Soft Trim              | 5                      |
| Power train            | 4                      |
| Exterior Systems       | 3                      |
| Wheels                 | 3                      |
| Carpet                 | 1                      |
| Brakes                 | 1                      |
| <b>Grand Total</b>     | <b>340</b>             |

Table 1 Functional sub-systems of Studio Designed Components and number of components

### 2.3 PD Organization in NA OEM

As a result of the experience developing products, technical expertise required to manage the components from concept to production, the OEM under study (NA OEM) has a matrix organization to staff with engineering resources each tophat with all the necessary expertise to build each product sub-system. Therefore, the architecture of current functional organization resembles the architecture of the current product, as new functions are added or deleted into the product, functional organizations are also added or deleted. The expertise is then mapped to staff

specific vehicle programs and accountability for cost and quality can be traced back to a component level Product Engineer.

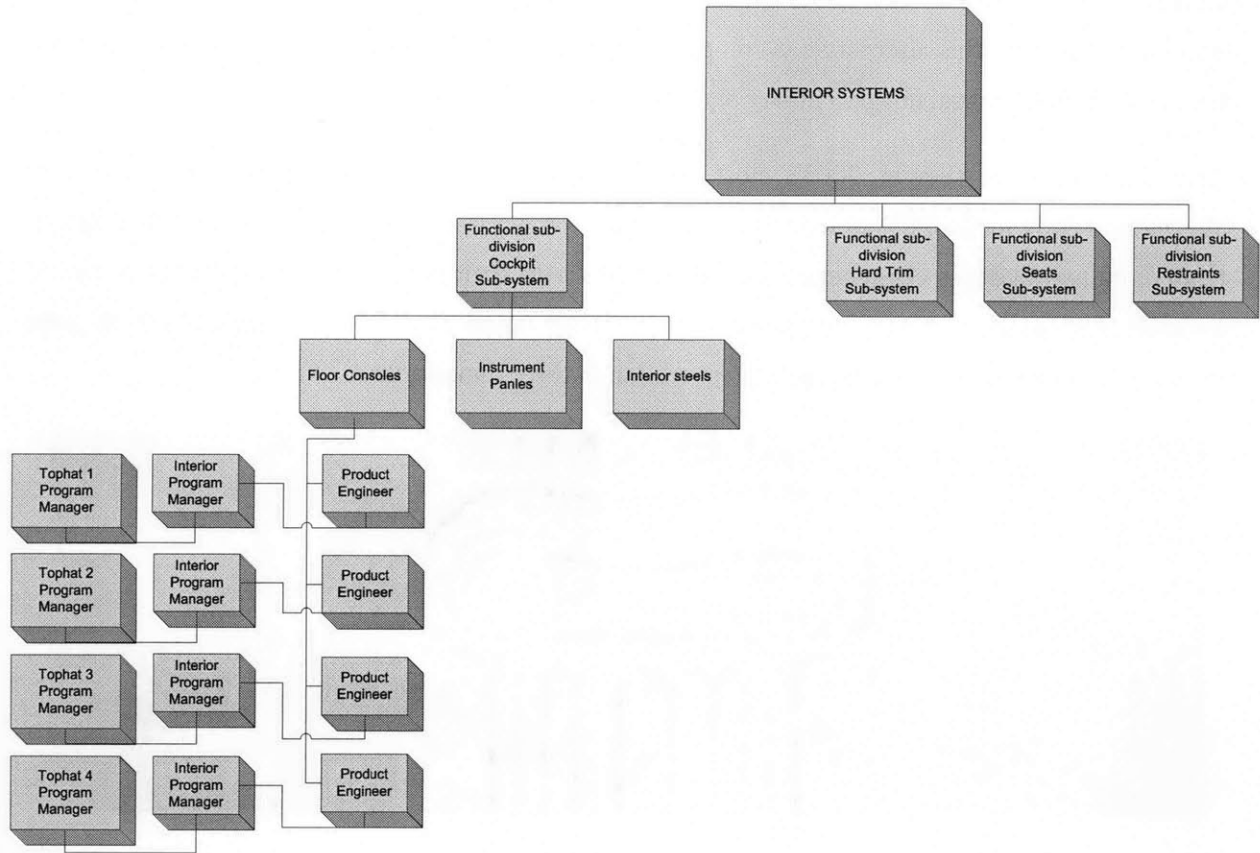

Figure 4 Functional staffing scheme based on component level expertise

## 2.4 Aesthetic design

The main focus of the aesthetic design is shape. Within the boundaries of a Product Development Process (PDP) the Design Studio is the organization in charge of defining shape of Studio Designed Components, such as exterior sheet metal, surface of visible portions of the interior trim, and all the controls that for which appearance and customer interface are important for market success.

Given its importance as a product attribute and the philosophy towards engineering in the industry, appearance design is earliest of all physical design processes in the PDP. Thus its definition in the Design Studio and execution in the Engineering organization can largely address project pace and product quality and cost.

## 2.5 Early stages

As stated previously, the styling definition process in the context of the entire PDP is front loaded. During the first stages of the PDP, the main purpose is to define the best styling alternative. As we will further review, this alternative is composed by a set of surfaces that interact together to form the entire vehicle's visual image. This set of elements is called theme.

According to Lewin (Lewin, 2003), most OEM's follow a traditional approach to define theme alternatives early in the PDP as soon as a new vehicle program kick-off is declared. At this point, a team of industrial designers generate several sketches with their proposals and sometimes generate 1:4 scale clay models to better communicate their design intent to the decision makers and to play with the proportions after seeing the representation in three dimensions.

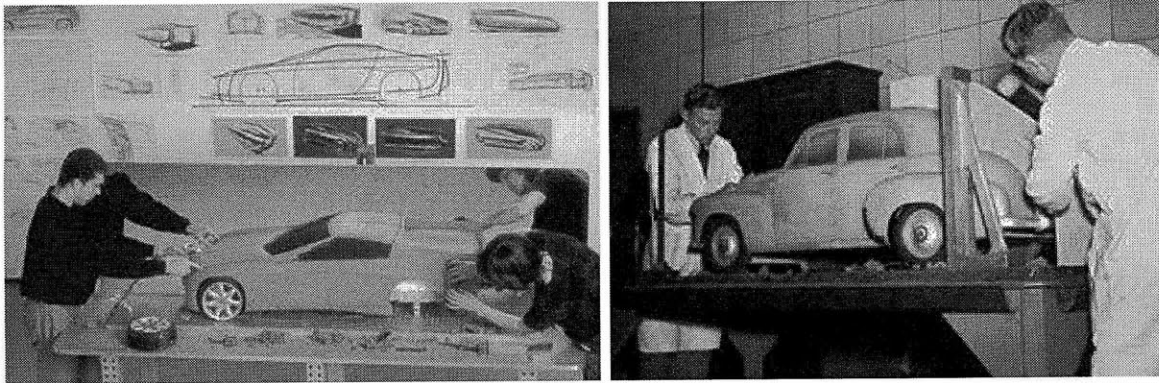

Figure 5 1:4 scale half mirrored model at GM (left) and Holden (right) from Car Design Online (Clay Modelling)

Theme alternatives are presented to the Studio managers and the OEM top management for assessment on brand DNA compliance and competitor trends analysis. The number of choices is then narrowed to about five and full scale models are built for market research. The main objective of this activity is to bring the voice of the customer (VOC) to the styling team to understand the trends and tastes and preference among different styling alternatives. Target customers are brought to a physical or virtual showroom-like environment and are presented with several vehicle options that include current segment under research competitors (or virtual re-touched scans) and physical (in-and-out or see-through hard models) theme alternatives for the new products. Badges are carefully hidden to avoid any brand bias and encourage subjects to focus on model features rather than cost, quality, functionality or reputation. Dealership representatives are also an important part

of the market research process as they are brought into the Studio during theme selection and refinement to provide direct input of the VOC about aesthetic features.

The feasibility process starts with the Body Engineering team after themes are narrowed to about three<sup>2</sup>. Although the previous themes had already been assessed for general proportions to suit the selected platform and some other systemic packaging and attribute studies were done up-front, we will see that it is at this point that the component level expertise evaluates the surfaces and provides visibility to the Program Management team about quality and cost.

Nevertheless, studio moves forward with the update of the appearance in a clay model normally called a feasibility clay. This is normally a manual process in which stylists provide direction to clay modelers to slowly represent the best appearance of the themes as information flows from Engineering. This means that throughout the feasibility process, the clay model is considered the master repository of the Class-A surfaces. This model is then used to style the appearance of the vehicle after constraints are detected by the engineering department through component or relational feasibility<sup>3</sup> and it is the main tool to accomplish pure design feasibility for both shape and surface quality.

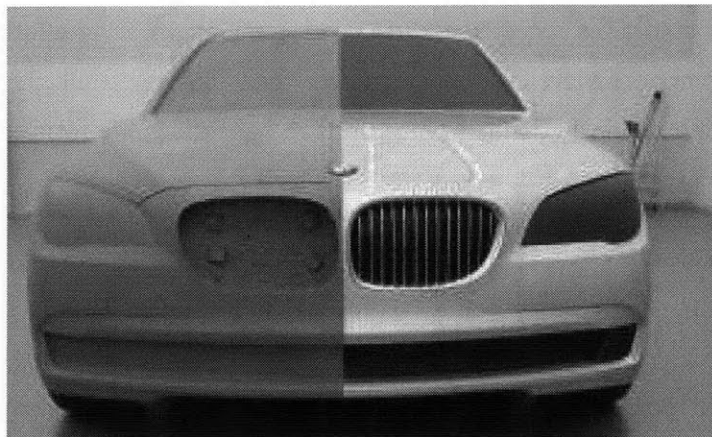

Figure 6 Full scale clay model of BMW 7-series (Vanderwerp, 2008)

---

<sup>2</sup> This number can vary among different vehicle programs, market segments, etc.

<sup>3</sup> The different types of feasibility inputs are explained in detail in page 35

## 2.6 Feasibility process

The main objective of the feasibility process is to quickly narrow the possible alternatives for product appearance, while at the same time, enhance economic and reliability performance, achieving exiting styling and optimize market viability within a single design intent. This process has an already fixed amount of time within the PDP in which the styling intent is expected to converge to a final state that is compatible with the Design and Engineering team. This is, the product looks well and achieves cost and quality targets. As an example, according to Liker et. al. (Liker, Ettl, & Campbell) three exterior main processes must be taken into account to assess the feasibility of the vehicle exterior. These are die development (planning, designing, building and trying out dies), part fabrication (stamping), and the assembly (welding) of stamped components.

McDaniel (McDaniel, 1996) conducted interviews within an American OEM and derived five questions that are internally and informally answered by the Body Engineering (BE) team and tracked by the Design Engineering (DE) team as the feasibility process of concurrent engineering progresses. Such evolution occurs in gateways that we will refer to as Feasibility Checkpoints (FC).

The organization in this OEM is managed at a component level, thus, the accountability for execution of vehicle attributes requires additional systems engineering efforts for discovery and addressing. These component level questions are iteratively answered whenever there are surface changes of any of the previously defined types until the questions are satisfactory answered. The questions are:

- 1) What is it made of?

The answer to this questions forces the engineering team to select the manufacturing process to create and decorate the part, thus to understand the constraints and concessions that will need from the Design Studio. The materials selection will normally be driven by the styling intent to achieve structural strength, robust decoration and repeatable assembly for fit and finish.

- 2) How is it shaped?

The answer to this question is important to understand a few manufacturing constraints, particularly for stamping dies and injection moulds. Sometimes it is also important for assembly since the surface shape may sometimes define an instrument panel that will not fit through the door<sup>4</sup> or will not be removable for service. There are more obvious implications of shape that will allow correct packaging of surrounding non-Studio Designed

---

<sup>4</sup> A sometimes significant assembly constraint



Components or functional attributes that will require shape compromises such as the head room or knee clearance to instrument panel for safety.

3) Where is it in space?

Without necessarily changing shape, some components may need to be shifted to better function. Human factors for visibility or “reachability” are the main drivers for this answer and of course greatly affect the appearance of the vehicle. Sometimes components such as cup holders or rear view mirrors are shared across vehicles but with different positions.

4) Does it comply (with customer, functional and regulatory requirements)? Surfaces can affect directly regulatory requirements such as unbelted head impact sharp edges, distracting or blinding reflections in the windshield, visual obstruction and reach of switches, packaging of active and passive restraints, thickness of robust roof columns for rollover, etc. In addition, there are functional requirements that are intended to fulfill customer satisfaction of the product such as cupholder size and position, storage space, roominess, etc.

Once current state of surfaces is compliant with all requirements or there is governance alignment to pursuit a deviation, the surfaces are said to be 100% feasible.

5) How much does it cost?

This answer will provide alignment to the program team towards approve budget for the vehicle to comply with corporate targets that allow a healthy balance sheet. Many times the surfaces are feasible for all the other 4 questions, nevertheless, the cost of building the theme as is, will not make good business case.

### *2.6.1 Feasibility process output: The surface*

It has been mentioned at the conceptual level, which is the importance and focus of the feasibility process, but in terms of instrumental information for further development within the PDP. The output and ultimately currency of the process is: the surface.

The role of the surface is to communicate information about current styling intent status and the relative position of the various elements of the design in the space. From the Engineering perspective, given that all vehicle surfaces visible to the customer are shaped by the Design Studio, it is necessary to have feasible surface from which a part can be build. Such surfaces are called Class-A surfaces. The outcome of the entire engineering process upon receipt of feasible Class-A surfaces is call B-side, and it formed by all the elements of a component that are not Class-A surfaces, such as clip towers, screw bosses, weld ribs, reinforcement ribs, etc.

Therefore, the surface is the starting point for engineering to begin component design performing various analyses depending on the component and the functional requirements that need to be fulfilled.

During the feasibility process, Body Engineering develops the Computer Aided Design model (CAD) of the B-side for most of the iterations, when the Class-A surface impacts the B-side. This Engineering discipline is also required to support tooling construction in Computer Numerical Control (CNC) machines using Computer Aided Manufacturing (CAM) interfaces.

It is important to emphasize the organizational responsibilities involved in the Feasibility process:

*Design Studio is the entity responsible for shaping the Class-A surfaces while Engineering is the entity responsible for shaping the B-side and assess that the Class-A surface complies with functional attributes.*

### ***2.6.2 Feasibility process inputs***

According to McDaniel (McDaniel, 1996), there are three main types of information inputs that will alter surfaces to achieve feasibility:

- 1) Component feasibility. - This is the main functional team input derived from the expertise in a specific component. This information is obtained from answering the 5 basic questions on component feasibility.
- 2) Relational feasibility. - This is the type of information that requires collaboration within the engineering team. This happens in the absence of physical interference (or sub-standard clearance for that matter) between components, and is meant to achieve conformance to regulatory and customer requirements. Then, surface adjustments on a given component must be evaluated for their relational impact on others. This means that the feasibility of every component requires ongoing information inputs from other components.
- 3) Pure design feasibility. - This is the type of information that requires more collaboration within the Design Studio. This happens in the absence of engineering constraints (component or relational) and is meant to provide consistent (and appealing) transition among individual component surfaces into a “correct” integral design. It is initially aimed to achieve global shapes and then to adjust surfaces to improve surface quality.

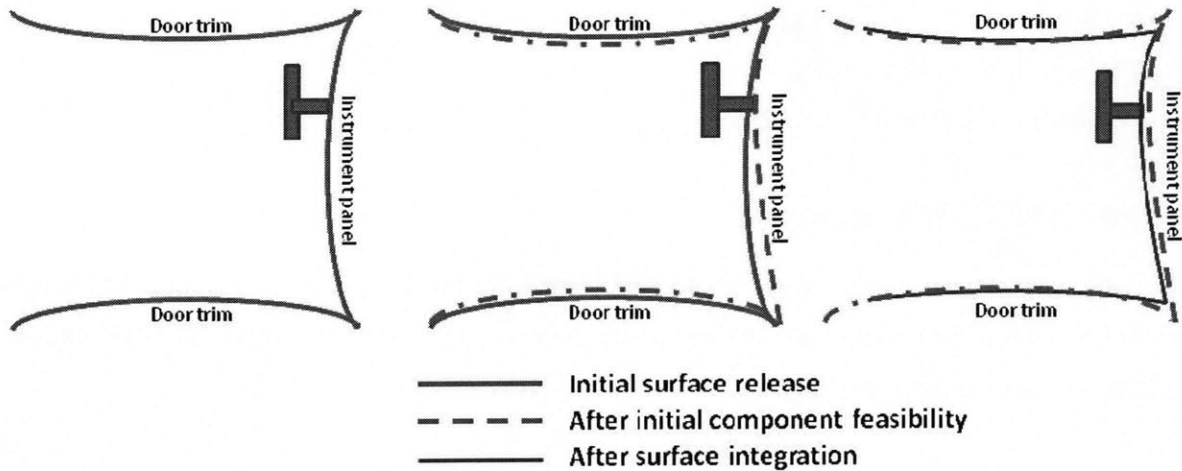

Figure 7 Surface change from different information inputs for door trim, and instrument panel

In order to achieve a good Class-A surface, Design Studio has two main criteria:

- a) Achieving a pleasing shape. - In this instance, Design Studio is concerned with the definition the set of all curvatures, edges contours and character lines that convey a common and appealing design language and ultimately define the surfaces in space.
- b) Achieving surfaces of high quality. - The intent is that after a theme is defined and enough engineering information is available to make the theme feasible, there are subtle adjustments to the surfaces to such as radii, continuity and consistency. The purpose for such fine tuning is to avoid undesired abrupt changes in some locations that can generate, for example, discontinuities in reflection highlights or non-smooth transitions.

To understand the difference, the Theme can be seen as a rough cut of the image, while the surface quality adjustments can be seen as the high definition level of design.

The understanding of these drivers for surface changes is important to understand the ripple effects that a surface change can have in the project workload, even in the absence of either technical or styling constraints. This is, even if feasibility for a component is reached at some point in time, that component is not necessarily complete until the entire system of surfaces “looks great.”

### ***2.6.3 Information exchanges***

The feasibility process requires three main types or information exchanges, and each of them uses specific information mechanisms to take place:

- 1) Between Body Engineering and Design Studio
- 2) Within Body Engineering
- 3) Within Design Studio

### *Surface release (Studio to Engineering)*

The way surface is communicated to the engineering teams is through electronic (CAD) files containing surface data. The source of these data can vary significantly from periodical laser scans of a clay model at each program gateway, to direct Computer Aided Styling (CAS) data.

### *Feasibility meetings (Engineering to Studio)*

This is a program recognized forum (formal) to discuss potential issues that the Engineering team identifies to make the surfaces feasible. They are typically held on a weekly basis and representatives of affected components, affected attributes and styling are present in the same room or in front a Power wall with a WEBEX or Netmeeting connection when teams are distant. The meeting is scheduled by the Design Engineer assigned to the program as he or she identifies issues.

This is also the mechanism for program tracking of feasibility progress, since Design Engineering keeps track of the status of the vehicle attributes, which at the end are the indicators that not only the component have autonomous feasibility, but the entire system is performed as intended.

### *Feasibility Sections (Engineering to Studio)*

Most of these studies and their corresponding output to communicate to the Design Studio are performed in sections in vehicle position.

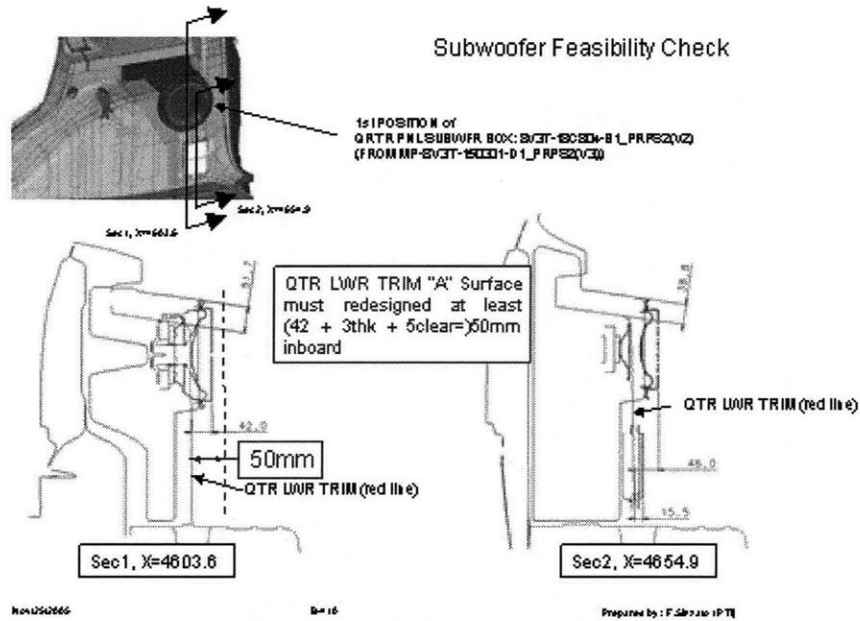

Figure 8 Rear Quarter Trim feasibility study (OEM under study)

Communicating through sections allows Design Studio to understand the specific location in-vehicle of a given constraint that will impact surface shape or quality. Thus most of the feasibility studies must contain the following elements to successfully convey engineering constraints to the Design Studio:

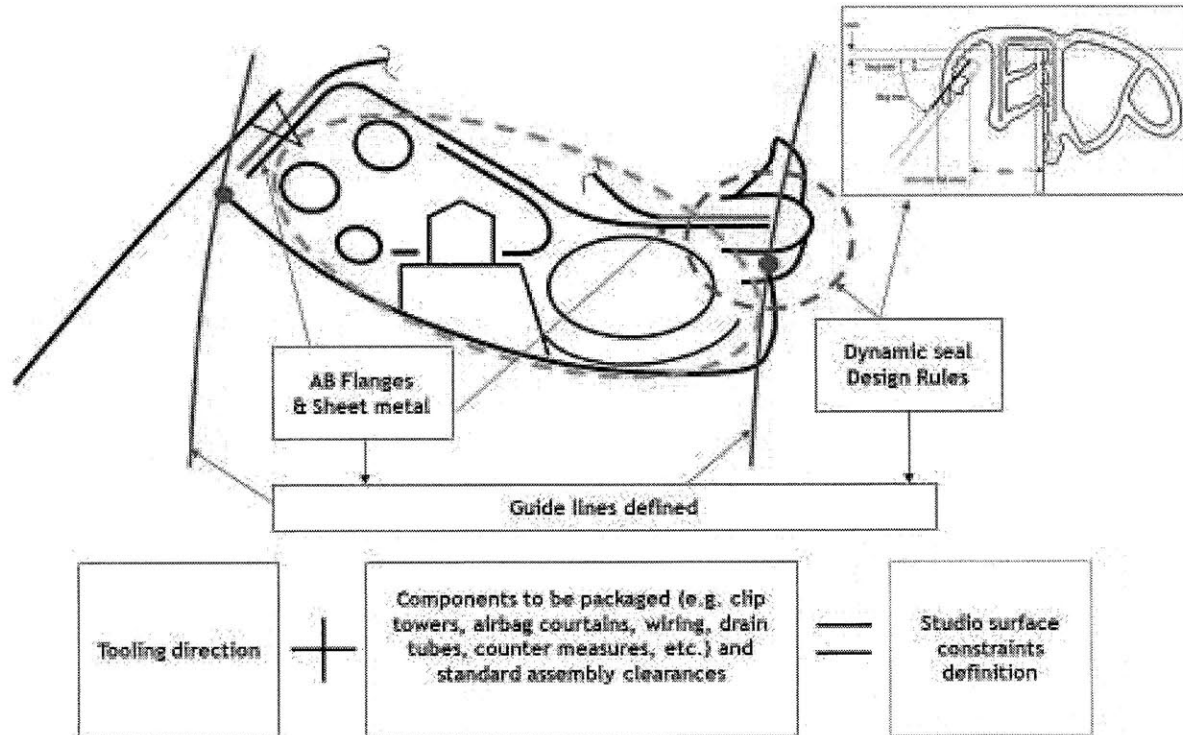

Figure 9 Feasibility Section generic content (OEM under study)

Both, surface release transmittals from Design Studio and Feasibility sections from Engineering are available to the entire program team members (and sometimes people outside the program) for review.

#### *Team collaborating CAD repository (Studio to Engineering and Engineering to Engineering)*

As the feasibility process progresses, Body Engineering releases the latest CAD version of the Studio Designed Components built from the latest surface release. This helps the packaging attribute team leader to run periodical checks to detect interferences or sub-standard clearances and feed them back to the appropriate component engineer to flag as a component level feasibility issue.

Both, surface releases and the component CAD files are stored and shared through the corporate collaboration CAD repository.

#### *Clay-walk arounds (Studio to Studio and Top Management to Studio)*

Clay models have traditionally been used as working tools for intra-studio communication. Everyone inside the Design Studio can see the hard model and provide feedback.

These events are almost completely informal; nonetheless it is rather frequent and is one of the main sources of styling driven changes. Although there are some scheduled visits from the upper management of the functional teams to review styling status of any give program, there are many times in which top executives walk around when their busy schedule allows it. Stylists also use this forum to express potential changes to the theme to internal studio management, studio colleagues and upper management and less often to the engineering group. Although the preferred communication channel from Studio to Engineering still is the surface transmittal.



Figure 10 Chris Bangle (BMW Chief Designer) in a Studio walk around (Car Body Design)

The use of these fluid and uncertain information mechanisms used to be impossible when dealing with distant teams unless there is a mill-back property (clay) on-site where the top executives are located.

Nowadays, with the more frequent use of CAS to reduce the PDP time, large displays are more often seen inside the guarded doors of the Design Studio to try to replicate the effect of having the hard model available all the time. In this journey the appropriate communication within the Studio is vital, since a fast feedback from colleges and management can improve the chances of better theme intent. According to Buxton et. al. (Buxton & al., 2000) the on-site design approval process can take up to 35% percent of the design cycle. The time and cost of building physical models has been one of the most important factors for such delay. This effect is seen for both co-located and distant projects. In this way, designer colleagues (on-site and off-site), managers and top executives can see

not only the latest status of a given program, but several mature alternatives that would not be possible to model and change in clay at the required pace.

*Computer Aided Styling (CAS): BMW Case Study (Thomke, Managing digital design at BMW, 2001)*

Today, most OEM's are familiar with the use of Computer Aided Styling software (CAS). Recently, new technological enablers for CAS make it possible to aid designers in considering several alternatives from the early brainstorming process, especially from its ability to predict the course of lines of reflection and the advantage to work digitally from the very beginning with direct data link to CAD parallel development and easier Concurrent Engineering (CE).

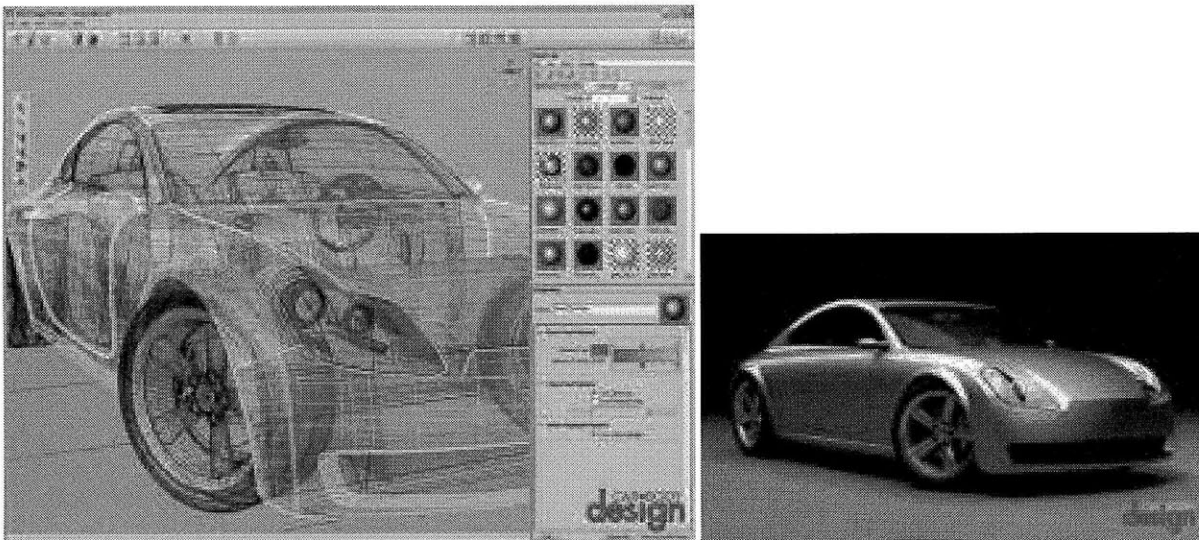

Figure II Surfaces release transmittal designed in CAS Alias (left). Rendered CAS surface in Alias (Body Car Design, 2005) (Body Car Design, 2005) (Body Car Design, 2005)

However, idiosyncrasies in the Design Studios of many OEM's have also posed a major roadblock to migrate to full digital Studio models. BMW attempted to migrate to this new approach in the mid 90's for the development of the 7-series as part of their strategy to reduce product development time by 50%. The objective was to develop a full tophat in 30 months, something unprecedented at the time and very challenging even today, since even Toyota does it in 36 to 32 months according to Morgan and Liker (Morgan & Liker, 2006).



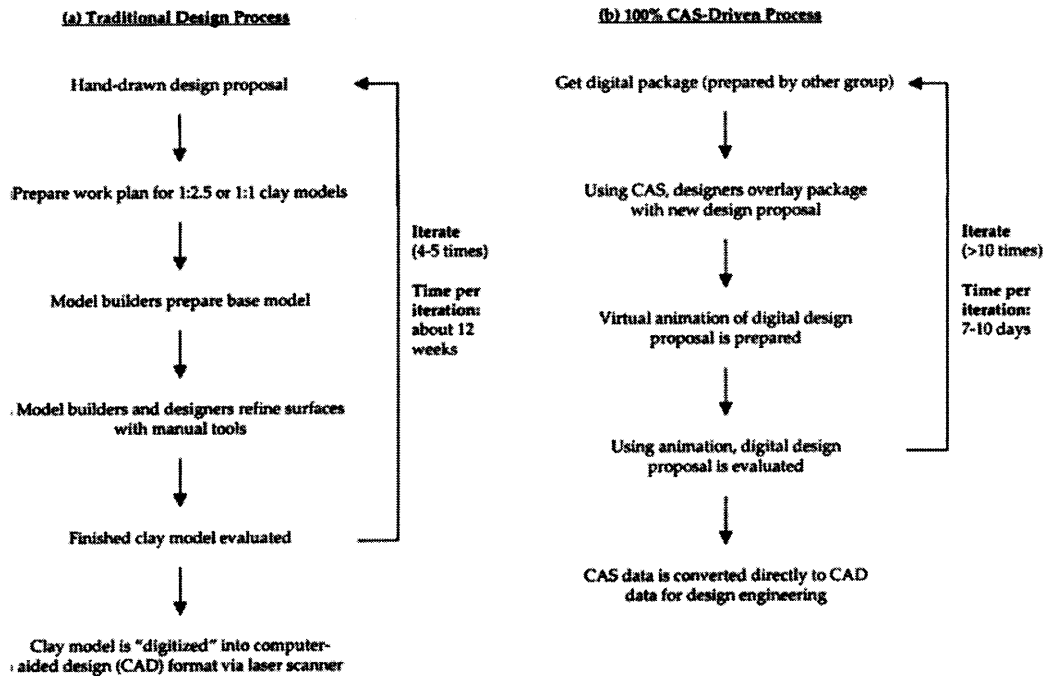

Figure 12 Clay Vs. CAS development time according to BMW (Thomke, BMW AG: The Digital Car Project, 2001)

They found that the work with physical models was an integral part of the training and emotional experience of a designer (Thomke, BMW AG: The Digital Car Project, 2001). According to Chris Bangle, BMW Chief Designer, traditional manual process allows for an enormous amount of human interaction with the surfaces. In an interview for the Design Management Journal, he recalls the experience of transitioning to CAS:

“It (traditional process) means you don’t have something so fixed in your head that all you are doing is execute, execute, execute. Instead, you have an idea, a direction, and you are trying to caress, love, and stroke it, and pull it out. There is truly a sensual relationship between the creator and the object, which is often written about in art. The same is true in cars. It gives you time to talk to the car. It gives you time for the car to talk to you. CAS basically says that we will simulate that effect and replace it with synthetic methods. Is it really the same?...CAS is basically in the hands of the *Formgestalter*s [modelers] because they’re the ones who have to come to grips with it. Where the designer came into play is in the interpretative end – *Is what I see what I think it is?* ... We believe that CAS is a tool that transforms surfaces to another basis than was previously possible. Having said that, don’t forget: In this case, the medium is also the message. That means that a car done in clay

looks different from a car done in plaster, than a car done in aluminum than a car done in a computer screen.”

BMW prided itself on its “handcraftsmanship;” Bangle declared that “cars are not machine-produced, they are machine-reproduced, a human hand makes every surface...we practice the artful deformation of sheet metal.”

This idiosyncrasy is part of the Design Studio understanding of artistic value that seems to be embedded into its culture. In fact, designers pride themselves when they are capable of building a system with subtle interplay of multiple surfaces that could not be easily created on a digital computer.

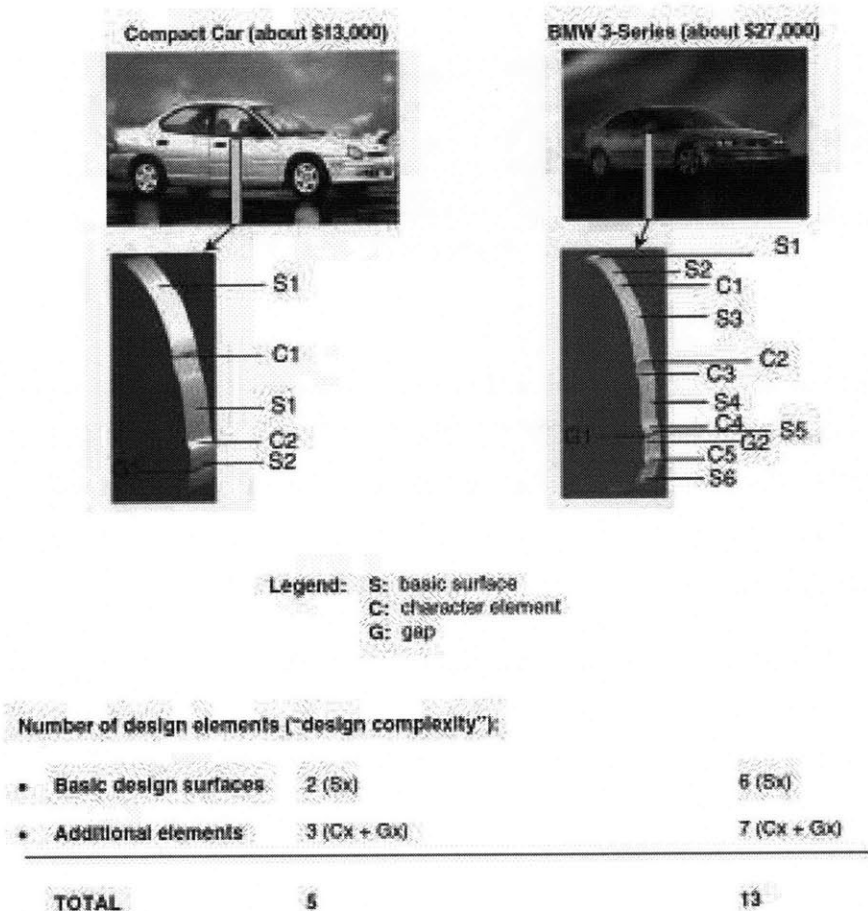

Figure 13 Comparison of design complexity between BMW and an entry level vehicle

Despite the resistance to adopt these new methods, after going through their first project, there were important lesson learnt:

- 1) “The use of digital technologies needs to align with strategic product positioning,” styling compromises would not be acceptable in BMW as it is very likely that it will not be acceptable in the future in any company. The fact that BMW underwent these issues to take on this new technology, suggests that such adoption will have similar problems industry-wide. As most customer valued features, styling trends start in the higher niches as lead adopters and slowly cascade down to the lower end customers (Katz, 2008). This cascading of perceived value is explained by J. Mays, Vice President of Design of Ford Motor Company:

“It is important not just for the car industry, but for any industry that produced products, that those products perform in such a way that there is tangible evidence to the customer that their quality of life has improved as a result of buying the product.” (Lewin, 2003)

- 2) The combination of CAS with traditional models generate the same value than current process but at lower costs and faster. In the time of Thomke’s case study, CAS was capable of performing at 80 to 90 percent of a traditional process. Eventually a new technology can replace an old one but it then will be challenged by an upcoming one. In this sense, having the ability to use both enabled BMW to use a hybrid process and optimize the delivery time Vs. performance trade-off.

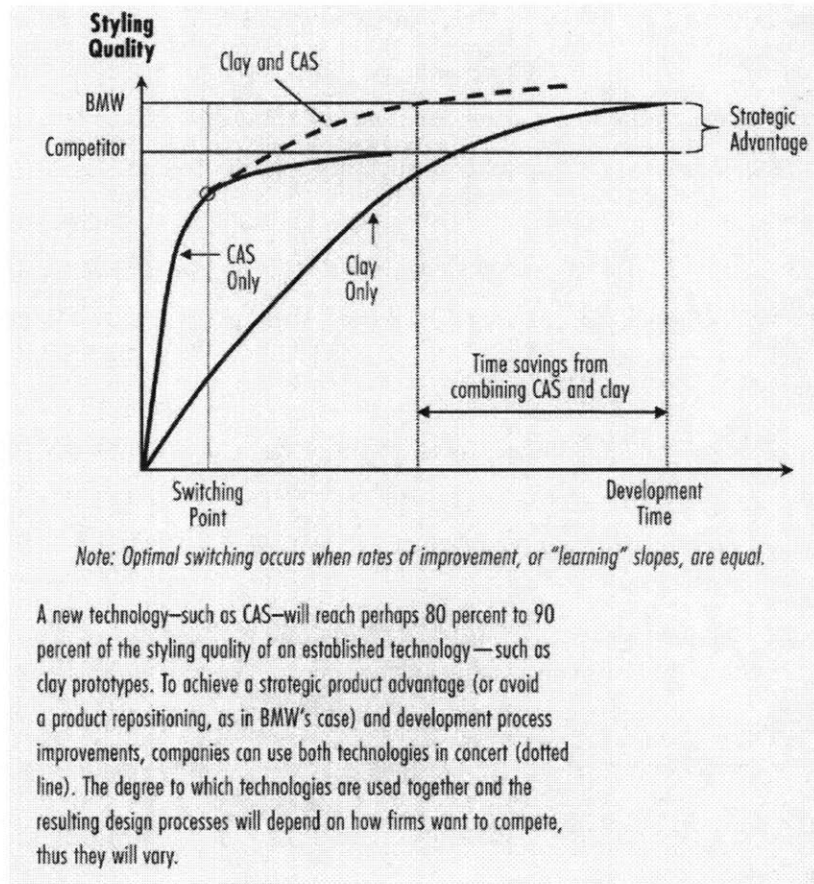

Figure 14 Performance of CAS and Clay Hybrid method

## 2.7 Design Studio Cultural Insights

Lewin (Lewin, 2003) conducted a thorough description of the Design Studio mindset from within the boundaries of this securely guarded space. Inside that isolated zone, the designers are responsible of delivering the emotional connection of the object to the customer. Vehicles are seen as products of massive heartless industrial machines that as a result of inspirational design have the opportunity to attain life and even spirit of their own.

Chris Bangle, BMW's Chief Designer describes designers as emotional, sensitive and often egocentric people who don't respond to cold, rational arguments. According to him, the designers see perfection as an ephemeral, almost spiritual quest that has to be achieved in stages, while for engineers perfection is physical and measurable, something to be done right the first time. In his experience, designers must be shielded from unintended but sometimes hurtful criticisms, because the exposure to too much premature resistance will make the designer quit the project: "Designers

are as emotionally attached to their creations as mothers are to their children, and a careless comment can be extremely damaging.” This is a reason why, when a project stage requires designers to gain intensive feedback from the engineers, they never face each other, Design Managers who have gained the trust of the designers and have a higher hierarchy in the organization act as mediators to filter any engineering change request (Bangle, 2001).

Bangle also highlights a major difference in the organizational architecture within the Studio. Designers are rivals that compete to get their designs into production to be driven by millions. That pressure alone is more than enough for designers to challenge their creativity, and additional cost, timing or quality discussions will significantly disrupt them. Again, there is a need to isolate the styling activity from the rest of the product development process.

During an interview, a Design Engineer describes the friction in the interaction between Body Engineering (BE) and Design Studio (DS) as a troublesome for several reasons.

“Sometimes an engineer’s assessment of surface is that it is not feasible, feeding back many changes that, from the designer perspective are not only important but also crucial to convey aesthetical intent and harmony. Many times designers attempt to search for the same concepts assessed as unfeasible among competitors and find that different from the engineer’s opinion, they are indeed possible. Therefore the trust bond is broken and the Engineering team is constantly challenged to search for a solution that satisfies the designer’s objective. BE can argue that a design is not feasible because it is “extremely expensive” or would have major system implications, but from the DS perspective that is not a BE call to make, but a program decision. Sometimes it is the lack of technical savvy what drives such assessment, but in any case, it is the program who should decide if it wants to pay for whatever is necessary to execute the styling proposal. It is also important to mention that when referring to studio related issues. The resolution requires having excellent people skills to convince each party that there may be an “in-the-middle” option that could please engineering requirements and styling intent. If the engineer and the designer had to work together, it is very likely that they break the relationship immediately and further issues are even more difficult to solve given the lack of willingness from both parties to address them.”

This requires decision making process that is elevated through stages until all parties are satisfied. As the decision gets elevated, the Upper Management decision principal of the NA OEM under study is clear: “Design Studio is King,” meaning BE will have to lead any effort required to deliver theme.

This tendency to favor DS can be justified from the understanding that as competition is intensified, aesthetic design becomes a strategic leverage to attract customers, because “good design is good business.” Good design is the business of giving the customer something they love and enjoy using (Lewin, 2003).

After several interviews conducted to two Design Engineers, one Style Designer, two Math Modelers and one Operations Manager from a NA OEM, they credit much of the success of a design to the emotional response the vehicle generates in a potential customer. According to the Design Studio team, this process has become rather difficult because it has to deal with the business constraints of platform commonality, but more importantly with the challenge of shaping forms that will be successfully received by the customer base two years down the road. The still long development times have resulted in catastrophic product launches as a result of the faster pace at which customer tastes change. Such was the case of the Mercedes-Benz S-Series 1991, which was designed for tastes of the early 1980s. Customers thought that the \$127,000 USD car was too large and unwieldy (Thomke, BMW AG: The Digital Car Project, 2001).

This specific argument has been surfaced repeatedly during the interviews with the Design Studio personnel and has been determined as the main basis for late changes for several reasons:

- 1) As the product develops the feasibility information provided by the engineering team, slowly changes the shape and results in loss of initial styling identity.
- 2) As time passes, competitors release new vehicles that affect the designs trend and thus affect the customer potential response to a design that was supposedly frozen.
- 3) Social events and rapid technological pace pose a higher demand for content addition, variable cost reduction and reduced customer operating costs (i.e. fuel efficiency) that affect engineering assumptions and are transfer to late styling changes.

The impact of these factors is amplified as time to freeze the styling intent increases driven by a large amount of time for development, tool making and validation. A successful Design Studio organization is capable of dealing with all these sources of uncertainty and a nearly fixed development time. In industry, the average time between theme selection and OK to ship is three years. During this period the surfaces suffer many changes, ideally decreasing in amount until frozen, but still the image must be kept after theme selection.

## 2.8 The Design Engineer Role

When describing communication patterns in Product Development, Morelli et. al. (Morelli, Eppinger, & Gulati, 1995) argue that communication does not need to be enhanced everywhere within a project but when and where it takes place.

In a co-located model, the Design Engineer functions as single point of contact for the Studio designer to ensure that the latest surface level has been reviewed and approved by Engineering. For all the component engineers, the Design Engineer is accountable for the either approve or get the appropriate approval that the changes they propose are acceptable for product appearance. Design Engineers are normally very experienced Body Engineers that help identify potential downstream issues, early in the feasibility process.

As former team members of the Body Engineering team, Design Engineers help to ease the communication and change negotiations between Engineering and Design Studio. As noted in Hansen et. al. (Hansen, Mors, & Lovas, 2005) research, the difficulty in transferring knowledge can be eased if the two parties know each other well. They must develop a common communication frame in which each side understands how the other party uses subtle phrases and ways of explaining difficult concepts.

This spoke and hub role requires a deep knowledge of the system as whole, from attribute stakeholders to component characteristics. Dong (Dong, 2002) defines this kind of knowledge as “System Level Knowledge” which consists of four parts:

- 1) What the system components are
- 2) How system components interface with each other to achieve the desired functions and the undesired systems behaviors
- 3) Who has the knowledge about each system component
- 4) Where to find the documented knowledge about each system component

The importance of the Design Engineer to assure the progress of the entire engineering team to avoid further risky and expensive changes derived from unacceptable surfaces for any stakeholder (customers, executives, stylist, engineers, manufacturers, etc.) poses major importance towards develop correct systems thinking for these individuals. Hence, Dong’s four component framework provides an important start point to understand the knowledge related competencies that are require for this systems champion.

THIS PAGE IS INTENTIONALLY LEFT BLANK



# Chapter 3

## Issues with current tophat development process

### 3.1 Approach to concurrent engineering during feasibility process

US automakers have tried to implement the CE approach through a highly structured PDP and multifunctional, often co-located design teams. However Liker et al. have found that Toyota's PDP is less structured than its US counterparts' having engineering activities spread geographically, often in different locations than their Design Studios of Tokyo, Toyota City, Europe and California.

Ward et. al. (Ward, 1995) define as a point-based design the one that the majority of US based automotive engineers were trained to use. This method (Shigley & Mischke, 1989) to problem solving suggest an iterative process of sequenced steps in which the engineer understands the problem by stages defined in each iteration and slowly synthesizes a solution. It is basically the iterative course present in current feasibility process.

Under this mindset, the fastest way to speed the engineering process is to accelerate the iteration loop by increasing communication. Therefore, collocation is the optimal solution to fulfill this mindset. Collocation is a strategy that is targeted to require engineers to meet more often to improve their communication; this face to face interaction is then enhanced when physical models and visualization tools are available.

However, Ward et.al. also reviewed Toyota's PDP and found a major difference that reduced the need for that close interaction loop. By using set-based CE, Toyota has reduced the amount of downstream changes to surfaces and thus *muda* (waste) in the form of re-work. As a result, the final

surfaces released to production are closer to the designer's concept given that the selection was made when there were more choices available. This approach also enables to have more reliable products because the feasibility process is front loaded and thoroughly done in as many as 5 theme alternatives, allowing to chose more developed themes that fulfill system (vehicle) level performance early before choosing a single theme to work and iterate from.

Nevertheless, this view is not compatible with the outlook of the NA OEM under study and in general from most automakers that have established design as their main priority, focusing all engineering efforts both in feasibility and in downstream fixes, using the best looking theme alternative only. This leads to major modifications to styling intent after theme is chosen, either driven from late feasibility changes, testing, etc. Set-based CE allows Toyota to provide almost full feasibility to many alternatives to choose the theme that looks better after the engineering performance uncertainty is reduced.

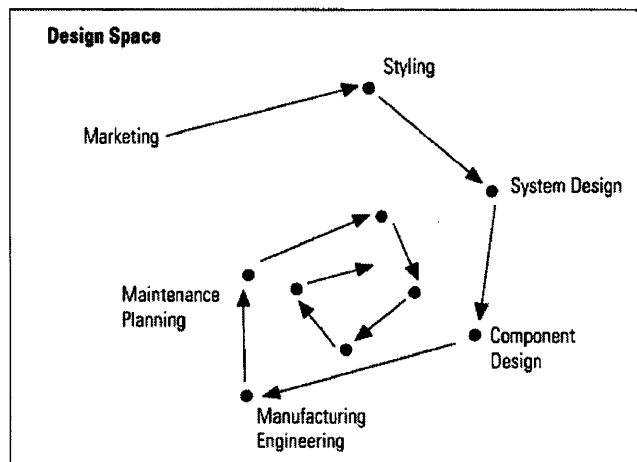

Figure 15 Ponit-based CE in current feasibility process at NA OEM (Ward, 1995)

In Toyota, Design Studio team and Body Engineering team work simultaneously and almost independently during the FP. While the stylists generate concepts and alternatives, engineering teams work in what is called the *kozokeikaku*, or K4. This is mainly a document that the functional teams prepare as soon as the functional content, technology strategy and platform are selected. This can be seen as an analogous to what US OEMs call Feasibility Sections or Master Sections. These drawing contain much of the legacy information related to the execution of components for a given vehicle architecture (platform + tophats). In essence, the use of K4 permits Toyota to have a lot of

re-used feasibility into a broader set of themes, improving quality and allowing keeping a larger amount of themes available almost prior to the final surface sign-off and theme selection.

As Morgan and Liker emphasize, Toyota enhances Design Studio creativity by using ratios and trade-off curves to grant designers more freedom during their feasibility process. Sobek et. al. recall

“Companies that do not keep design standards must rely heavily on verbal communication between functional groups and mental maps of the design space acquired through experience... U.S. design standards tend to prescribe single solutions (e.g., "piston rings shall meet specification xxx" or "flange angles shall be y"), rather than describing a range of acceptable alternatives, resulting in a rigid, stifling design environment.” This is pivotal for Toyota to achieve richer, better and less communication between their teams during Product Development, hence essential for having less interaction and better distant collaboration. There are more options to provide feasibility to a single theme and there are more themes to which provide feasibility, therefore final styling and engineering intent is more optimal than with the traditional model. (Sobek II, Ward, & Liker, 1999)

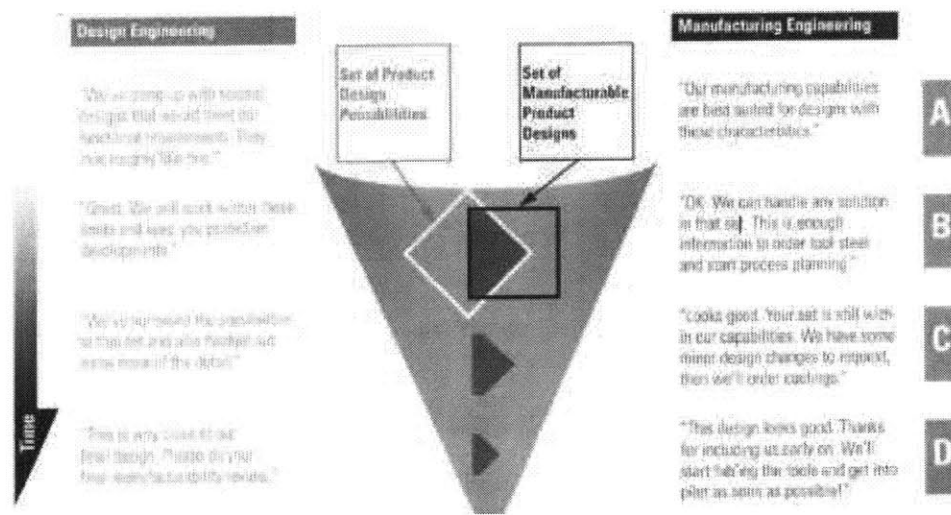

Figure 16 Set-based feasibility process at Toyota (Sobek II, Ward, & Liker, 1999)

### 3.2 Standardization of platform feasibility information

A well-known philosophy developed by Henry Ford was to standardize complex manufacturing tasks in order to make them routine and predictable (Liker, Ettl, & Campbell). In this sense, Toyota has followed such approach into its Styling feasibility process by identifying infeasible

designs and systematically recording them in checklists, thus requiring stylist to avoid some extreme body curves early in the Studio process. (Ward, 1995).

One important characteristic of the NA OEM PDP is that it is focused mainly on leveraging hardware reusability by maximizing commonality and sharing vehicle architectures. When dealing with distant teams to develop a specific variant, a lot of the information from the base program was reused to design the variant. However, when a new tophat is to be designed off the same platform, most of the knowledge is only resident within the engineers. Dong (Dong, 2002) highlights the need to re-use documented System Level Knowledge to avoid the need for experts to perform the re-engineering effort of understanding the component interactions. Her investigation showed that System Level Knowledge is poorly documented and therefore rarely re-used if the engineer is not available. This is particularly important for the Design Engineer, whose role is to be the system level champion for surface feasibility.

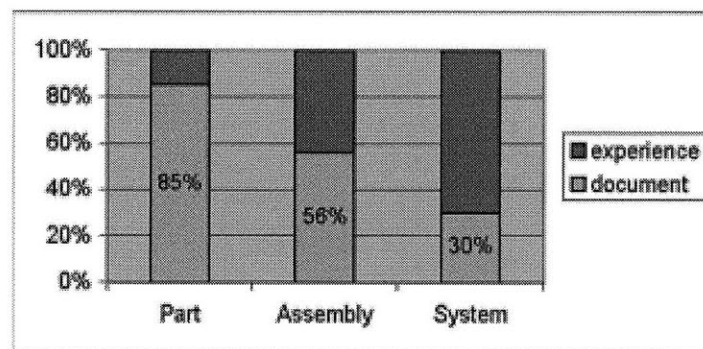

Figure 17 Location of throttle body design knowledge in Ford Motor Company (Dong, 2002)

This is expected, given that the engineering knowledge is highly tacit and goes wherever the engineer goes. After finishing the surfacing process, each engineer moves to validation, verification and launch phases of the project, taking the feasibility knowledge with them. When the product is approved to be shipped, engineers are then assigned to a different program that may or may not be based off the same platform, and thus the knowledge has to be re-created for the new tophat. The lack of a platform mindset to plan the feasibility process drives the need to start from the scratch every tophat program at initial surface release.

In most cases, hard points such as the floor pan, suspension and engine packaging are known. Also, all driver (not necessarily all occupants) position and requirements are set based on platform. Even most of the attachments such as welding spots and clip joints have been defined from a legacy

program based on the same platform. This is particularly important for the Straight-forward Engineered Componentes (SFEC's).

This approach has been the result of the OEMs' outsourcing of engineering. Each tophat program team worked with different Full Service Suppliers (FSS's). Thus the feasibility process needed to be repeated for each derivative off the same platform to match each supplier design and manufacturing guidelines and economic strategies, as long as the suppliers were capable of designing the subsystems according to system and performance specifications provided by the OEM. Nevertheless, as OEMs start bringing most of the tophat engineering in-house, the need to repeat such process becomes minimal, since information should be freely shared within the company.

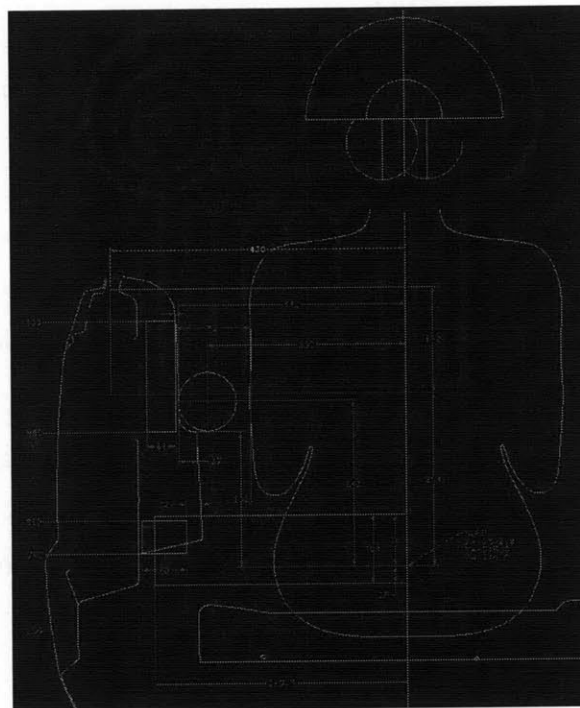

Figure 18 Occupant position is carried over different tophats (OEM under study)

Thus, much of the feasibility process driven from the legacy platform program has been already developed and could be easily adapted and carried over to the following tophat program. This can be achieved not only by documenting the feasibility sections after the surface transfer process, but also, doing so after design testing is done in a previous tophat. These sections should now show all the appropriate B-side elements for that tophat to successfully deliver requirements.

By improving the leverage of platforms, we are able to shift from a purely hardware focused commonality across tophats to a leaner knowledge shared platform mindset, avoiding re-working engineering solutions.

### 3.3 Inter-subsidiary communication noise

As part of the organizational culture, there are some threats that impede correct information sharing. Hansen et. al. (Hansen, Mors, & Lovas, 2005) identified that the transferring of tacit information and complex knowledge across organization subunits is a function of the nature of informal relationships between the two parties in a transfer. This study shows that the product developers within an organization have formed enduring relations among them and tend to systematically overvalue local group members and undervalue nonmembers. This is also known as the “non-invented-here” syndrome. Over the years, the close interactions of different functional groups to deliver common projects have resulted in the need to embrace a common knowledge base and a common set of specialized set of terminologies. Also, there is an increased awareness of each other’s knowledge, including awareness of knowledge that may be relevant to project-specific tasks. In essence, an organization that has historically had more processes in-house and thus, solved more problems without the need of a subsidiary organization is less prone to have adequate information transfer tools and willingness to use them.

Hence, teams that have been isolated from outside interactions form negative perceptions about others. Also, this study reveals that as the tacitness of the information to be transferred increases, an existing shared communication frame becomes more important, because an increase in the strength of the established relations between teams reduced the total number of engineering-months spent on a project.

Therefore the two parties in a transfer can rely on such frame to articulate, modify, and incorporate the subtle and implicit aspects of the tacit knowledge.

Another important phenomenon that Allen (Allen, Architecture and Communication among Product Development Engineers, 1997) identified is that there is a higher probability of communication between workers in close proximity. This means that as geographic separation increases, the probability of communication asymptotically approaches a lower bound. He discovered that a pair of co-workers located 30m apart, have nearly the same probability of communicating as those who are separated by 250km. However, our research has shown that the communications between the engineering team and the Design Studio normally happen at longer distances than 30m. In Chrysler, for instance, engineers are not allowed to see and interface with the

clay model. Design reviews are held in front of a secured power wall (rear projection HD screen). At Ford, engineers are rarely allowed into the Studio, unless there is a specific issue that could be easier to see in a physical model or that the designer requires quick and direct input from the engineer before adding clay to the property.

### 3.4 Cultural differences and expectations

The Chief Engineer in charge of architecting the PDP of the NA OEM under study highlights that it is important to remark that geographically distant organizations have developed legacy expectations and rules. These have evolved over time to generate different system requirements or have a different approach towards the common ones. This has been driven by differences in customer expectations inherent to different geographical and cultural backgrounds. In this regard, the inter-subsidiary cooperation has resembled more to the interaction of two completely different companies historically separated and presently competing for their individual stake within the project.

Communication in complex organization is often something that is taken for granted. Smallman and Weir (Smallman & Weir, 1999) argue that in real life situations, this process is limited by their expectations and perceptions, both of these vary among cultural and social settings. Companies have tried to manage the impact of these perceptual differences, but as soon as individuals become part of the operating system, Bella (Bella, 1987) points out that “modern organizations distort information to meet organizational needs.” Such groups then will distort aspects of the risk in support of their own beliefs and values.

Upon review, according to our interviewee there are two main challenges to overcome in order to achieve distant interaction of teams:

- 1) Viscous communication. - Got through the meetings without surfacing the issue.
- 2) Different expectations. - Important information to assess surface feasibility is not easily accessed. The different expectations create resistance in sharing an assessment that may not be compatible.

Individualism and initiative are proven to be effective for preventing communication and cultural distortion during crisis because it enables fluid communication by dissolving the matrix and bureaucratic grid. Proactivity and individualism are then a must in the team leaders that are likely to work during crisis sensitive tasks such as those expected to happen in distant programs.

Organizationally, for the case of the OEM under study, on the one hand, the way technical organizations are normally managed, promote the setting of objectives in terms of performance, investment, knowledge of the customer, quality and cost in a product component level. This means that each functional team will assess whether a particular styling concept meets applicable component criteria. McDaniel defines this as “autonomous feasibility.” According to Allen (Allen, 15.980 Organizing for the Innovative Product Development, 2008) (Allen, 15.980 Organizing for the Innovative Product Development, 2008) this is expected given the difference in technical expertise that is required to develop each component. As we have previously stated, this leads to a lack of visibility of overall system level feasibility and attribute performance, which in distant projects lead to an increased number or required messages to finally converge into a final feasible design.

On the other hand, Design Studio is normally divided in only interior and exterior design. Therefore the Design group ultimately has the responsibility for the shape and surface quality of interior or exterior as an integrated system.



# Chapter 4

## DSM of a Tophat development project

### 4.1 Introduction to the DSM

A Design Structure Matrix (DSM) is a two-dimensional matrix representation of the structure or functional relationships of objects, variables, tasks or teams (De Weck & Haberfellner). It highlights the inherent structure of a design by examining the dependencies that exist between its component elements. A key contribution of the DSM literature has been to highlight that the degree of modularity of a design depends not only on the number of dependencies between elements, but also on their pattern of distribution (MacCormack, Rusnak, & Baldwin, 2006).

In the literature, DSM's have been identified with different names such as:

- Design Structure Matrix (DSM)
- N squared matrix or diagram
- Dependency Structure Matrix
- Adjacency Matrix

Within the Systems Engineering context, there are mainly four types of DSM's:

#### *Object based DSM*

In this Matrix representation, columns are physical objects and the entries are structural links with direct relationship.

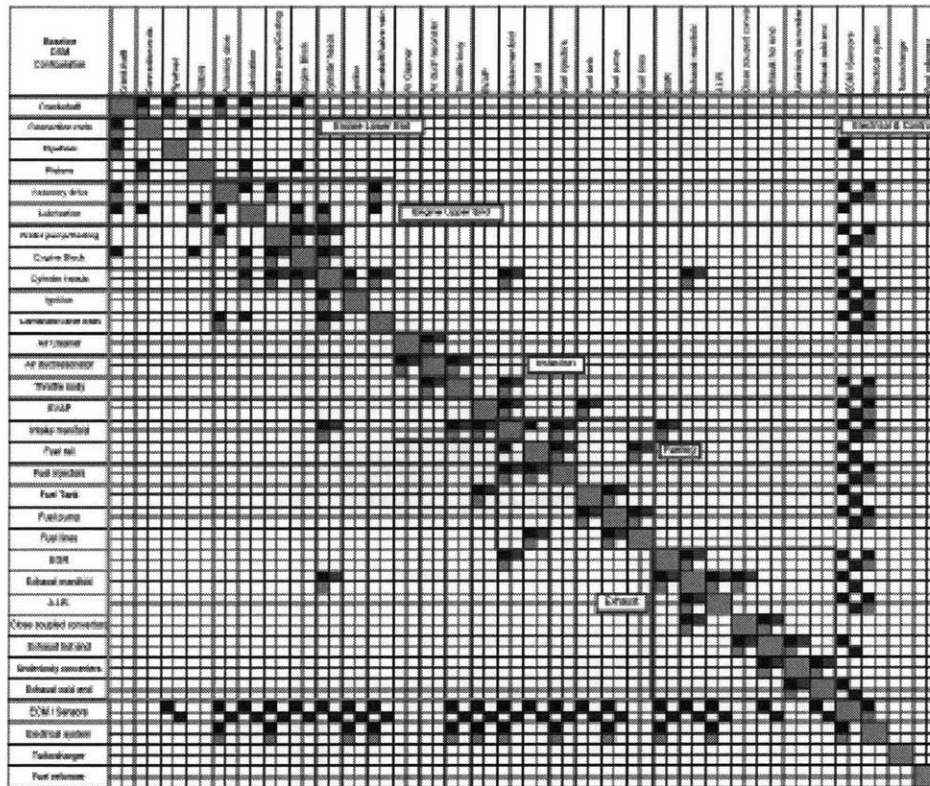

Figure 19 Internal combustion engine object based DSM (Smaling & de Weck, 2007)

This is helpful to understand the cluster of elements that form the physical structural components of a system. Consequently, it serves as a system architecture tool to map function to form and, upon analysis of an existing architecture, aim to make the appropriate design changes to improve modularity.

### Variable based DSM

This representation is mainly used to map incidence or occurrence that indicates which variables are present in which equations within a system of equations. For instance, the following system of non-linear equations can be represented in an incidence matrix to define the order in which each smaller set of equations should be solved to gather enough information to solve the next ones.

$$E_1: x_1x_2 - x_3 + 1$$

$$E_2: x_2 - x_5 + 1$$

$$E_3: x_1 - x_4x_5 - x_3 + 1$$

$$E_4: x_5 - x_2 + 1$$

$$E_5: x_2x_5 - x_2x_4 + x_2 + 1$$

The variable occurrence matrices unordered and ordered are presented below:

|    | x1 | x2 | x3 | x4 | x5 |
|----|----|----|----|----|----|
| E1 | 1  | 1  | 1  |    |    |
| E2 |    | 1  |    |    | 1  |
| E3 | 1  |    | 1  | 1  | 1  |
| E4 |    | 1  |    |    | 1  |
| E5 |    | 1  |    | 1  | 1  |

|    | x2 | x5 | x4 | x1 | x3 |
|----|----|----|----|----|----|
| E2 | 1  | 1  |    |    |    |
| E4 | 1  | 1  |    |    |    |
| E5 | 1  | 1  | 1  |    |    |
| E3 |    | 1  | 1  | 1  | 1  |
| E1 | 1  |    |    | 1  | 1  |

Figure 20 Incidence Matrices from De Weck & Haberfellner

By re-ordering the system in this way, the first block of  $E_2$  and  $E_4$  can be solved for  $x_2$  and  $x_5$ , then there is enough information to solve  $E_5$  for  $x_4$  and then move to solve  $E_1$  and  $E_3$  for  $x_1$  and  $x_3$ .

### Team based DSM

DSM's can also be used to represent organizational structures. This DSM is normally the output of interviews with team members in terms of interaction and informational needs. Then it is meant to be re-ordered into tightly couple teams of people that require close interaction. We will further review this type of DSM when we analyze the team based DSM of a tophat project.

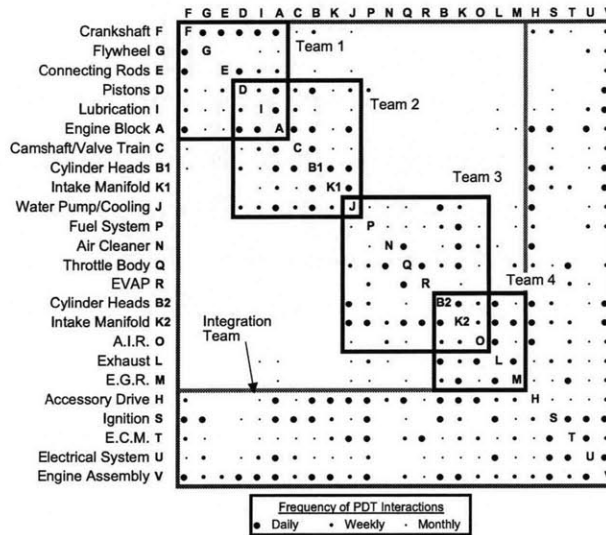

Figure 21 GM Engine Development team (De Weck O., 2008)

## 4.2 Task based DSM as Project Management tool

In this form of DSM, the sequence of tasks that compose a project is transferred in a squared matrix format under the following criteria:

- Tasks are information processes that require a finite known set of inputs and produce a finite set of outputs.
- Inputs can come from upstream or downstream tasks.
- Inputs into a task are represented in the rows (horizontally) and outputs into a task are represented in the columns (vertically).

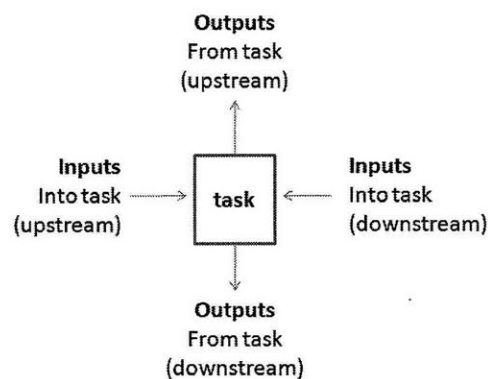

Figure 22 Information flow criteria for task based DSM

Projects contain activities that sometimes have to be repeated, but the number of such iterations may not be known in advance. Iteration is defined as the repetition of tasks due to the availability of new information in the project's upstream tasks, updates of shared assumptions, and discovery of errors from the project's downstream tasks (De Weck & Haberfellner). This is the main motivation of the use of DSM as a Project Management tool.

According to De Weck there are three possible sequences for two tasks:

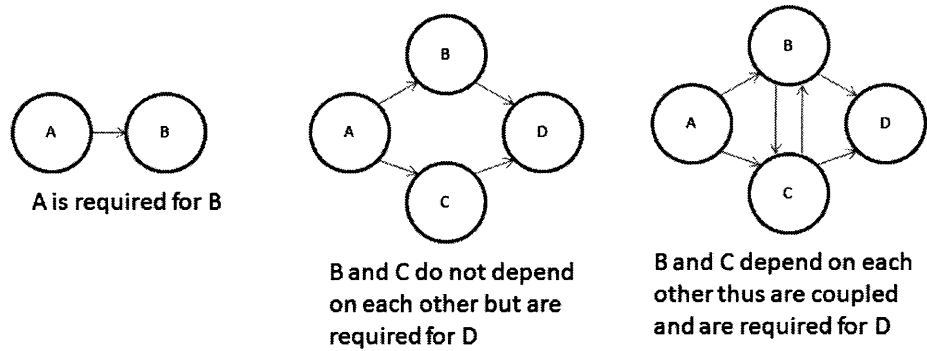

Figure 23 Possible sequences of tasks in a project

Project tasks may be coupled for several reasons:

- Tasks depend on each other for mutual input information
- Both tasks are partially overlapped and partial information from one into the other is later available.
- There is a mistake in an upstream activity that was later discovered and the set of processes is repeated as the upstream activity is corrected.

The Work Breakdown Structure (WBS) can be used as a system decomposition tool that enables the use of the DSM to modularize the process.

### 4.3 Modularity in the PDP

The outsourcing of the different functions within the Product Development Process (PDP) to an internal subsidiary demands a great level of modularity within the organization. Similarly a more in-house approach supports a more integrated architecture. Examples of this trend are seen in the open source development projects, which are normally characterized by highly distributed teams of developers around the globe that add functions, find and fix defects and even write proper documentation. Although the level of abstraction of software development is higher than that required to define a detailed physical object, these developers encounter the same constraint under study: they may never meet face to face.

MacCormack et al. (MacCormack, Rusnak, & Baldwin, 2006) researched the difference in modularity between the open source and “proprietary” software and found that the development methodology differed in that the later tend to be staffed by dedicated team members who are co-located and thus, have easy access to other team members. This work stream incentives the information sharing about solutions in different parts of the code and therefore having a more

coupled product. As a result, open source software is often claimed to be more modular than “proprietary” software.

The fact that the internal subsidiary organization has the flexibility of starting their strategy with a “clean sheet” can be seen as a great opportunity to improve the process, but at the same time it creates a challenge to better interact with the core organization’s legacy architecture. The central organization’s interfaces are well defined and expectations are established to a great extent, to work within a geographical and cultural setting.

As a result, the DSM is aimed to help define the appropriate key stakeholders that require closer interaction to perform the Engineering metatask of the PDP design phase. Moreover, this tool will surface the interfaces required to perform specific tasks with stakeholders that are not allocated in the subsidiary organization given the nature of their activities.

## 4.4 DSM construction

### *Stakeholders*

In order to determine the elements of the DSM, it is important to define the tasks and stakeholders champions in charge of them. In general, each stakeholder is represented by a manager of the functional group that will allocate engineers to lead the task execution. In some cases, tasks are conducted by cross-functional teams; nevertheless there is always a functional champion accountable for the task deliverable.

### *Tasks*

As it has been noted in the previous chapter, the PDP is highly complex and requires many stakeholders sharing information continuously. Hence, the WBS developed for this study has been simplified to highlight the most important activities that have a clear output required by another functional team to move forward in the value stream.

The detailed WBS structure required to design and engineer a tophat can be found in Appendix C

## 4.5 Analysis of the DSM

### *4.5.1 Partitioned DSM & the staged process modules*

This clear definition of the metatasks and Concurrent Engineering loops aims to understand two important aspects of the design phase: modularity and interfaces.

Upon completion of the dependency mapping, the DSM was partitioned using the algorithms of Problematics Inc. software package Problem Solving Matrix 32 (PSM32) to create an optimal task sequence that could facilitate the identification of highly iterative sets of tasks (metataasks) that would require a larger amount of CE among its team members. These algorithms determine the optimal sequence of tasks that create the fewest number of upper diagonal interactions.

A detailed “zoomed-in” version of both the raw and partitioned DSM is shown in Appendix D.

After partitioning the DSM, the metataasks of concurrent interactions are clearly defined as shown below.

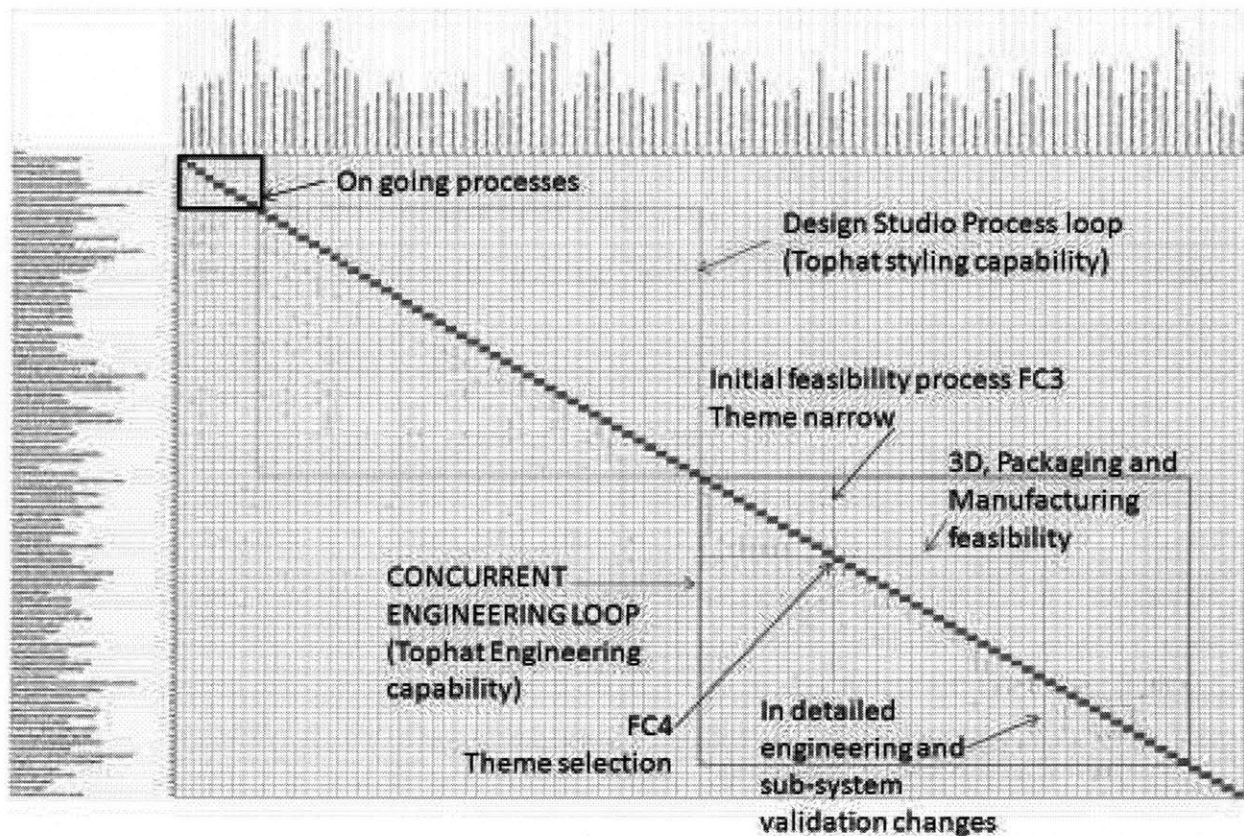

Figure 24 Partitioned DSM with identified loops in the NA OEM PDP<sup>5</sup>

<sup>5</sup> Given the large dimensions of the DSM (98x98), tasks are not clearly visible. A readable version of the WBS is in Appendix B and another one of the DSM is available in Appendix D

This resulting staged process is intended to drive the uncertainty of choosing the best styling alternatives and then creating a product by using, to a great extent, reverse engineering methodology for SDC's. From the chronological sequence derived from the partitioned DSM we can identify the difference in the Design Studio intensive processes in red and the Body Engineering intensive processes in blue. It is interesting to see that both loops are de-coupled at a clear "hand-off" point in time called Feasibility Checkpoint 3 (FC3) in the PDP after theme narrowing and program targets setup. After a thorough review, engineering, purchasing and finance determine costs targets for the different alternatives, that interaction can be seen in the Initial Feasibility loop FC3. This means that past this gateway there is enough Engineering information of cost and functionality and enough Styling information to freeze the image and move forward with detailed design and development at what is called FC4.

From the DSM it is also apparent that all the Engineering information created before FC3 is supplied by Design Engineering and Vehicle Engineering rather than Body Engineering who incorporated after there is clear theme intent to provide quality and cost status to the theme alternatives. This is helpful for the decision makers to have all the additional information besides appearance to select a single theme.

*On-going process metatask*

The first part of this clearly staged design phase is dependent upon on-going activities derived from corporate strategy. These activities must feed the brand DNA and thus give clear direction to the styling team as to where the company's distinct trend is pointing. In a more technical perspective, these activities also pose initial constraints to develop certain products that are approaching their life cycle, as well as the manufacturing sites that are suitable to support a new life cycle business case. In the same way all these time dependant tasks yield to the selection of a reliable and profitable platform that will suit the nameplate technical and business needs. These tasks and stakeholders are presented below.

| <b>Activities</b>                  | <b>Stakeholders / Champions</b> |
|------------------------------------|---------------------------------|
| Vehicle Line Cycle plan definition | Directors                       |
| Brand DNA definition               | Styling                         |
| Technology Cycle Plan definition   | Engineering Management          |
| Customer and Marketing concepts    | Marketing                       |
| Commodity business plan definition | Core Body Engineering           |



|  |                         |
|--|-------------------------|
| Define functional content based on Consumer Report Best Buys | Pre-Program Engineering |
| Initial Color and Material intent                            | Styling                 |
| Define functional component and system requirements          | Core Body Engineering   |

Table 2 Activities and stakeholders required for PD ongoing process (not program specific) loop

*Design Studio process metatask*

The second part of this apparent staged design process is dedicated intensively to the styling process, which is why we named it the Design Studio process metatask. This is one module of 41 activities that is aimed to execute program specific tasks focused on aesthetics intent definition. As such, this period is characterized by continuous benchmark of attributes that can have a large impact in the proportions of the vehicles and thus may be suitable to drive image changes to the product surfaces. This is the segment of the process in which stylists translate the sketches into real platform constrained proportions and create physical models to understand all angles of their character lines and are evaluated for attribute compliance. Once all functional attributes are accomplished by the surfaces or otherwise highlighted for the BE team to assess.

*Engineering process metatask (Tophat capability activities)*

The third big metatask defines the activities that are highly engineering intensive. They are dedicated primarily to deliver the themes as part of their objective. This requires a lot of interaction among the engineering teams because the sub-systems start to be developed in-detail but with the constraint of the system boundary that is fixed by the form factor resulting from the theme selection process. In this stage, there is actual construction of the “B-side” to the surfaces and thus, packaging of SFEC’s is either defined, or surfaces are changed, updating the previously assessed attributes. This change in assumptions yields planned iterations since the surface changes can affect the entire vehicle. Therefore, new information about each component delivered attribute is available in CAD form at each new surface release.

Consequently, this step is highly technical and labor intensive. In the same way, it tends to gradually become less emotional and thus it is an area in which low cost country subsidiaries can create the most value by delivering functionality to an appealing set of surfaces. Therefore, any organization responsible to engineer a tophat must be capable of delivering these activities. Hence, by identifying the stakeholders that interact in this metatask, we are able to address one of the subsidiary

organization needs, which is to define the functional knowledge that requires close interaction to engineer a tophat.

The stakeholders involved in the concurrent engineering loop required to accomplish Tophat engineering capability are:

|  |
|--|
| All Engineering teams (non-Body Engineering) |
| Body Engineering                             |
| Cost Estimation                              |
| Craftsmanship                                |
| Decision Makers                              |
| Design Engineering                           |
| EMM  |
| Final assembly & service                     |
| Packaging Engineering                        |
| Program Management                           |
| Purchasing                                   |
| Studio mill shop                             |
| Styling                                      |
| Supplier                                     |
| Vehicle Engineering                          |

Table 3 Stakeholders involved in the concurrent engineering loop required to accomplish Tophat engineering capability

Further studies must address the cascading process of such requirements into competencies models that ensure quality execution of the engineering process.

**4.5.2 The functionally arranged DSM and interfaces**

Besides the modularity of the system derived from the task based DSM, the ability to have the operating system decomposed at a task / owner matched pair level also permits us to apply a principle of system modularization that is aimed at identifying interfaces with stakeholders outside of the subsidiary organization. This yields to the identifications of key interfaces that must be revised in order to transfer information through organizational boundaries.

To accomplish this, the author manually re-arranged the DSM to allocate the tasks in functional blocks, to identify those that need upstream information from a functional team outside of the

subsidiary organization. In order to test the hypothesis, such stakeholders are those belonging to the decision making and Design Studio functional teams.

The resulting DSM is shown in Appendix D. The general structure however, has the following forms depending upon the information flow direction:

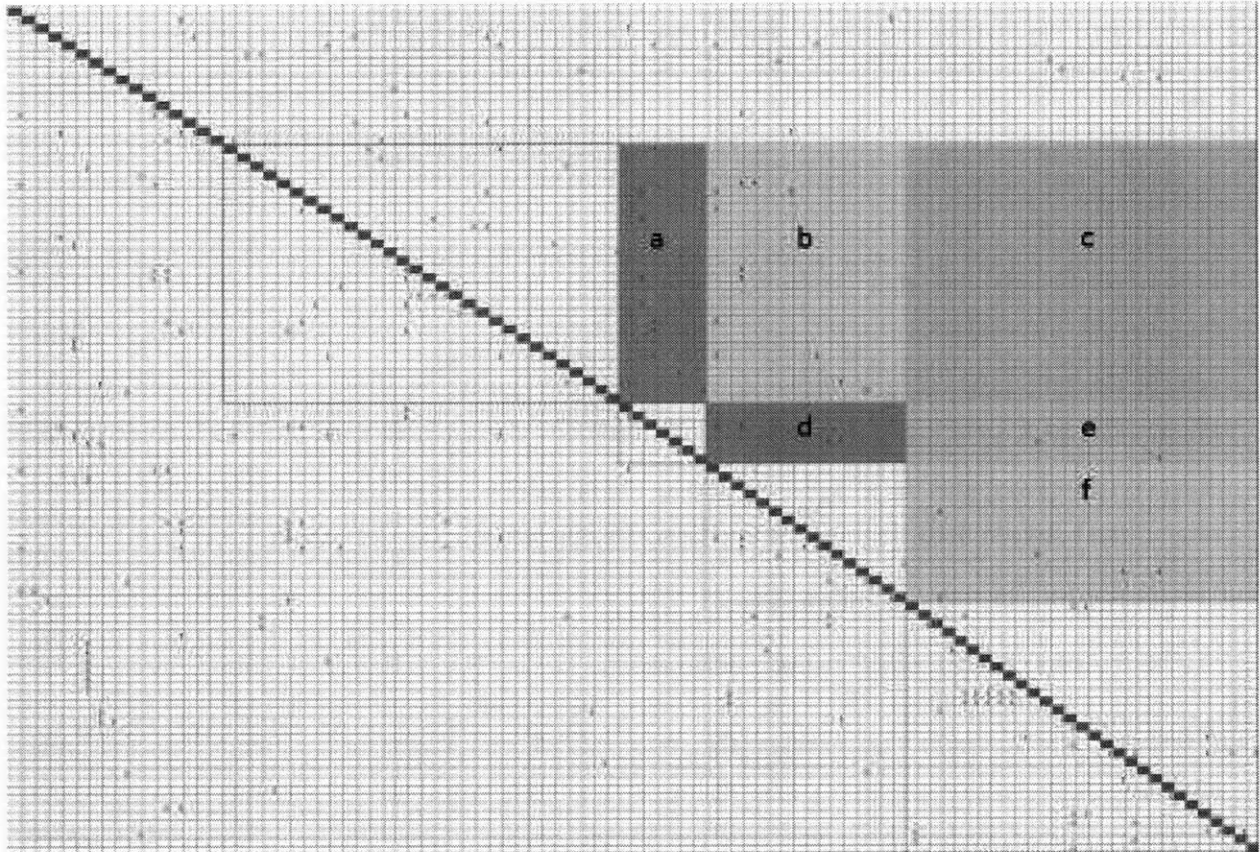

Figure 25 Upper information flow of interface DSM

In this first set of interfaces between different functional teams the information flow is labeled as follows:

|  |
|--|
| a) Information from Design Engineering to Design Studio      |
| b) Information from Program Management to Design Studio      |
| c) Information from Body Engineering to Design Studio        |
| d) Information from Program Management to Design Engineering |
| e) Information from Body Engineering to Design Engineering   |
| f) Information from Body Engineering to Program Management   |

Table 4 Upper information flow / interfaces

It is important to note that the subset of interfaces C which map the information flow from Engineering to Design Studio is empty. This means that as the project freezes the image of the vehicle, Design Studio only provides design direction to Engineering. If the design is proved feasible, Engineering undergoes many activities with the Program Management team to provide costs, trade-offs and ultimately appearance approval based on the Studio intent. Nevertheless, subset E shows interaction between Body Engineering and Design Engineering in two key tasks:

- 1) Generate alternatives for theme compliance
- 2) Propose and negotiate changes to surfaces

These concurrent engineering tasks create an interface that helps Body Engineering select the alternative that will better satisfy Styling intent by closely working with the experienced Design Engineers before feeding back any changes to the Styling team. Similarly, the second set of interactions is as follows:

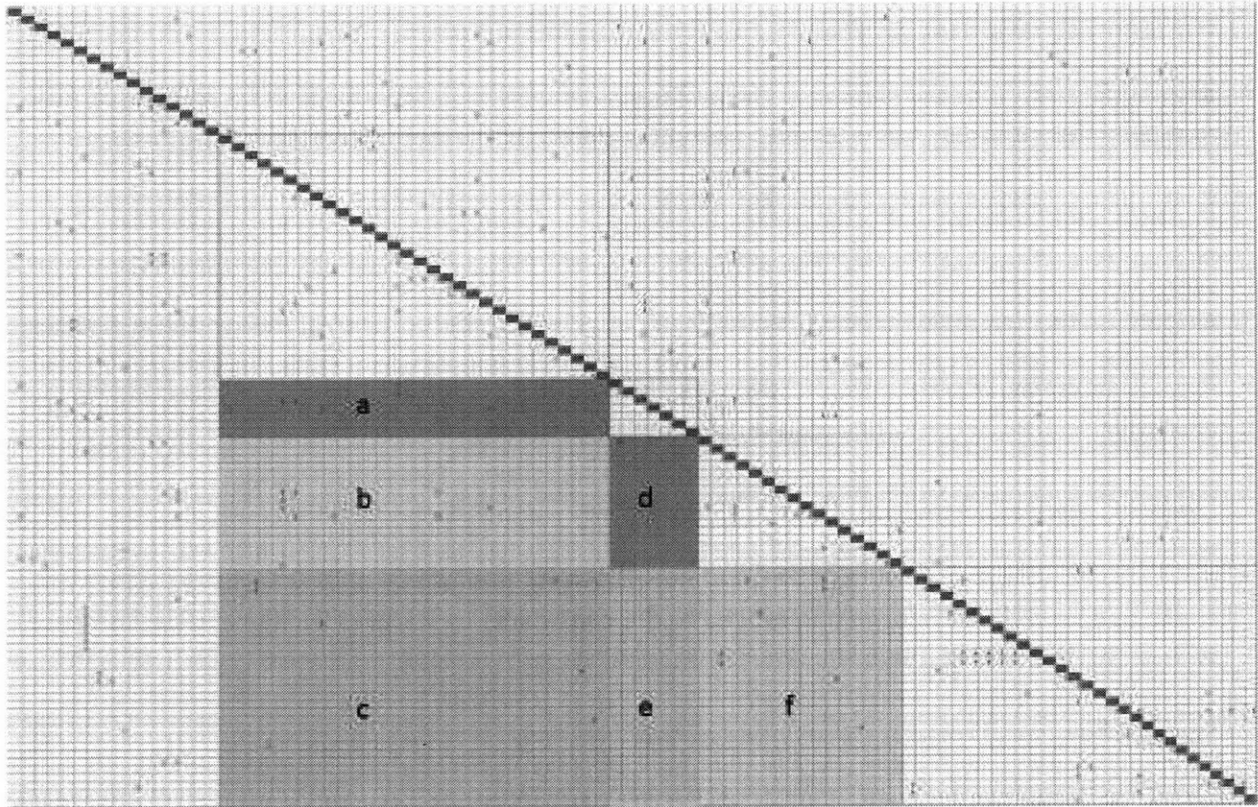

Figure 26 Lower information flow of interface DSM

In this second flow mapping, the interactions are labeled as follows:

|  |
|--|
| a) Information from Design Studio to Design Engineering      |
| b) Information from Design Studio to Program Management      |
| c) Information from Design Studio to Body Engineering        |
| d) Information from Design Engineering to Program Management |
| e) Information from Design Engineering to Body Engineering   |
| f) Information from Program Management to Body Engineering   |

Table 5 Lower information flow / interfaces

In this case, the Design Studio feeds appearance direction to Body Engineering through 6 clearly defined tasks:

### *Initial part breakup definition*

After initial surface image definition, Design Studio provides their Styling intent for part breakdown to show different colors, textures and materials.

### *Initial Color and Material intent*

When initial part breakdown is released, the Coloring group releases their first intent for finishes. As part of the feasibility process, Body Engineering examines options to deliver these finishes within the surface release constraints to avoid changes in the surfaces. Then the best option that delivers surface and finish intent is presented to the program for variable cost, tooling and timing approval.

### *Update occupant and mechanical package*

As the systems are adapted and change, the packaging group and Design Engineers within the studio update the CAD information related to the constraints to achieve function and performance such as hip room, head room, knee clearance, loading clearances for serviceable components, etc.

### *Surface change in 3D models & feasibility clay*

When information is updated from the Design Engineering team upon revision with Body Engineering, if the surfaces that define the Styling intent require changes, the Design Studio is responsible of updating the surfaces either through a clay modeling process and a later scanning or directly using a CAS application that can be migrated to CAD.

### *Final surface release*

Upon completion of the feasibility process and when there is a full knowledge of the design constraints. Design Studio provides final styling direction as part of their surface release.

### *Color and Materials direction*

When all the cost, trade-offs and surfaces are known, the Coloring group within the Design Studio is responsible to release the final color and materials intent. This allows Body Engineering to fulfill cost, quality and styling program targets.

## **4.6 DSM Considerations**

There were a few considerations that had to be addressed for the development of the DSM for this specific work.

#### *4.6.1 DSM completeness*

MIT researcher Dr. Daniel Whitney developed a measurement to assess if a DSM has captured enough information about systems interactions (Dong, 2002). By conducting a thorough research on different DSM's developed by researchers, Dr. Whitney defined the density ratio of a DSM as:

$$\text{System Interaction Density} = \text{Total number of off-diagonal marks} / \text{total number of rows}$$

He acknowledged that the past DSM's exhibited a density ratio of 6 regardless of the matrix size. Therefore, this number has been used to assess whether the DSM contains enough information about the systems interactions. In the case of our PDP Design Phase DSM the ratios are:

$$\text{PDP Design Phase DSM System Interaction Density} = 233 / 98 = 2.377$$

This is a low ratio compared to that required to assess the DSM as complete. According to Dong, there are some reasons for DSM's to have such a low level of interaction density. In this specific case, the system has been could have been optimized through generations to reduce the degree of coupling. In this case, the PDP has been decoupled to an extent that allows easier communication with external entities such as Full Service Suppliers (FSS's) who used to engineer most of the SDC's.

Most importantly, since the marks-per-row density is hypothesized as being a reflection of the human cognitive limitation when dealing with complex systems, reducing the amount of system elements in the DSM allows having more flexibility in choosing the number of sub-systems. The level of decomposition could have been greater if it was conducted down to the commodity level, mapping each information deliverable to and from a stakeholder. This would have required mapping exclusive activities that each commodity undertakes at an individual engineer level. This is beyond the thesis scope and would require intensive participation and resource allocation within the sponsored company to achieve. In this matter, the level of analysis must be meaningful given the context. We chose to analyze designs at the functional organization level because they are the building blocks that needed to be identified as important for the subsidiary organization to achieve tophat capability. Therefore, this level of analysis describes the extent at which managers influence the PDP, so the subsidiary organization allocates the correct amount of expertise to perform only engineering related activities.

Nevertheless, since there is also a possibility that not all the interactions are being mapped and that a lower level of hierarchy is required to understand the real difficulty inherent in the process, the

following chapter will analyze in more detail the lessons learnt from past programs that have gone through a similar setup, with special focus on the interface between Engineering and Design Studio.

#### *4.6.2 Design studio considerations*

It is important to keep that the Studio process can greatly vary among different vehicle programs based on market scale, resource allocation and scalability. Different from the detailed and disciplined engineering process that is required to fully engineer to specification each component, the Design Studio process is highly capital intensive, especially because the cost of its labor force time is particularly expensive (executives, designers, clay modelers and EMM's who are in high demand) and the model creation requires investment in special facilities and machinery.

Additionally, the machine availability and the fast pace of technological improvement in the IT Industry can drive changes in the way internal processes are conducted in the Studio for every new tophat. It is important to acknowledge that this is a process that is done only once for each new vehicle launch and thus is strategically optimized in a tailored fashion to fulfill each program needs.

The objective of this WBS is to depict normal work streams undertaken for a full Tophat development in a generic approach. Understand in the minimum amount of information and its dependency among stakeholders in the added value transfer network.

#### *4.6.3 Engineering considerations*

The large amount of different commodities (components) that hold different requirements, specifications, manufacturing constraints and associated attributes would make it unfeasible to map them in a detailed individual activity level. There are nearly 150 different engineers involved in a single tophat development project. The number of tasks and unintended iterations will be highly dependent upon tophat architecture, which in turn is an outcome of the design theme, organizational structure and commodity based technology strategy and commonality across vehicle lines.

Therefore, the granularity of the engineering activities researched was amplified up to a level that will still allow mapping of individual added value tasks generated by specific stakeholders, and individual non-added value but necessary tasks that tackle trade-off and decision making milestones. As a result, many lower level activities such as specific CAE modeling for individual requirements as well as knowledge seeking or internal functional processes have been wrapped into single tasks owned by the functional team that is intended to perform such actions.



#### *4.6.4 Attribute considerations*

The uncertainty tied to high level system performance and its requirements cascade is managed through corporate checklists, 3D release of performance targets and CAE models during the development phase. Thus, the attribute assessment added value tasks are mapped as a single activity, assuming that the attribute team has the capability of assessing on the informational inputs and seek knowledge and validation methods through successful managerial practices.

#### *4.6.5 Program management considerations*

Although the ownership of specific tasks is clearly defined, it is assumed that the program management team is aware and holds the latest information generated from each tasks. However, the outcome of the study will provide insights about the importance and difficulty of information transfer and thus highlight the need for specific instruments to control the coordination communication.

Additionally, Dong describes two inherent weaknesses of the DSM method (Dong, 2002). First, DSM can only be used to analyze existing products and processes, because it requires detailed understanding of the system interactions and therefore re-use it. Second, the method for acquiring information normally involves interviews with experts. This creates a biased view of the process as it “should be” instead of how it “is.”

It is then a very good tool to model targeted behavior of a legacy system’s from intended outcomes view, but still requires detailed understanding of how the communication takes place to define internal system interactions in reality. This is the reason why besides understanding the mature model of product development, we will further review additional cases in which these interactions occur in a distant set, to document the lessons learnt.

# Chapter 5

## Lessons learnt from case studies

### 5.1 Former distance interaction between US OEM and other subsidiaries

Taking advantage that the Design Studio planning team is a consolidated cluster of knowledge about all US sold programs, we conducted interviews to seasoned team members of the US OEM that have undergone several vehicle programs managing interaction between Design and Engineering. We could summarize the following projects in which the company has used this approach for product development:

| Vehicle program         | Model year | Engineering Location | Engineering responsibility | Design Studio location | Design Studio responsibility |
|-------------------------|------------|----------------------|----------------------------|------------------------|------------------------------|
| Compact vehicle         | 1994       | Japan                | JPC                        | USA                    | US OEM                       |
| Compact vehicle         | 1995       | Europe               | US OEM                     | USA                    | US OEM                       |
| Small SUV               | 2001       | Japan                | JPC                        | USA                    | JPC                          |
| Sub-compact vehicle     | 1994       | Japan                | JPC                        | USA                    | US OEM                       |
| Cargo truck             | 2006       | Europe               | US OEM                     | USA                    | US OEM                       |
| Compact vehicle variant | 2012       | Mexico / Europe      | MEX OEM                    | USA                    | US OEM                       |

Table 6 Former programs with distant interaction between Design Studio and Body Engineering within the organizations of the OEM under study<sup>6</sup>

---

<sup>6</sup> Refer to the List of Acronyms

### *5.1.1 Sub-compact vehicle 1994: Interaction among NA OEM Design Studio, JPC Engineering and KPC manufacturing*

This sub-compact car vehicle (B segment) had new interior and exterior on the base engine, chassis and underbody of a previous sub-compact car. This was the first attempt to achieve a global vehicle that was going to be marketed in NA by the US OEM in Japan and Australia by the JPC and in Korea by the KPC. Given that the largest and most profitable market was the US, the US OEM had the Styling responsibility, for which it allocated a team of designers in Detroit to develop the vehicle design close to the marketing team and top executives to review the progress. At that time, the US OEM still had 33% of the JPC stake, reason why it tried to leverage its assets and expertise in engineering great quality vehicles. The JPC then was responsible of engineering the vehicle. Finally, since the US OEM also had stake in the KPC, it was responsible for manufacturing the vehicle globally in Seoul.

Since most of the project burden was going to be carried by the JPC in Japan, the project was outlined to follow their PDP the 2 years that the distant interaction part of the program lasted until surface freeze. In order to have constant and timely communication, the US OEM allocated two liaison engineers that fed information on open issues and feasibility sections. These two engineers were Japanese nationals but reported directly to the US OEM branch in Japan. This provided an incentive to engineers to talk in favor of the US OEM stake but at the same time, understand the language and culture of local engineers.

Information was transferred daily in scheduled conference calls. The US OEM residents reviewed all the issues and proposed changes from the styling and then fed them back mainly in the form of feasibility sections. The Design Engineer leading this information flow from Japan into the Studio recalls: "Back then we did not have the advanced CAD databases that we have today to share full CAD information fast and confidentially. When the JPC requested a change our residents worked with the engineers to develop 2D hardcopies of the sections that showed the proposed change to the styling surfaces and then sent them via fax! Since we had daily calls between US and Japan, we knew which the issues were and what information we were to expect, so when the sections came we knew which area of the vehicle had to be modified and the section showed the detail that should be transferred to the clay. When we updated the proposed change into the clay, we then modified it to integrate the style to show the change while achieving acceptable appearance. We then fed the new surface section back to Japan and Korea to show in their clays. This step was necessary because the vehicle was going to be marketed by the three companies, so the last level of the clay model had to be available for all three companies' upper management and marketing specialist for theme

research. Having a copy of the model at each location also allowed the engineers at the JPC to be sure that all their changes had been included into the latest clay model. Also, we had face-to-face meetings every two months at different locations (Korea, US or Japan). We met for a week to review the latest clay model with the upper management of all companies, the designers and the liaison engineers to agree on styling intent status. These meetings occurred more frequently in Japan to also interact directly with the engineering team and address as many issues as possible on-site or bring information back to further review.”

In retrospective, according to our interviewee the project seemed to run smoothly, with minor issues due to the time difference, this is, there were some urgent businesses that needed immediate feedback to avoid stopping the engineering work for a day and that could be easily solved with a phone call, this led to late night unexpected conferences. However, one key enabler that he identified was the use of the JPC PDP and the Engineering approach to it: “We always knew that the project was progressing appropriately. Nevertheless, here in the US we are more used to include changes directed by the upper management or the styling department at any point in the PDP. The JPC would not allow that. Their process is much more disciplined and once they said pencils down, it was really pencils down. In that sense, we were able to propose a few late changes after some escalation of the issue. The fact that the process was disciplined helped to slowly reduce the amount of information that needed to be transferred as the process progressed and also allowed the engineering team enough time to thoroughly review the design and achieve better quality and cost in the product.”

### *5.1.2 Small SUV development: Interaction between NA Design Studio and JPC Engineering*

In 1999 the NA OEM started a project to develop a new small SUV to close the market gap between compact vehicles and SUVs. The car was built on the platform developed by the Japanese partner and this was the reason why the lead engineering activity was allocated to in Japan for the tophat as well. The Design Studio was then also led by Japan but with close interaction with the USA based executive stakeholders through a milled back clay model available for review. The program scope was to develop one tophat with enough differentiation to market a vehicle for each brand in the US market. Different from other distant projects, the NA OEM sent the project leadership team to Japan to provide timely feedback on studio and engineering issues during the feasibility process. After the appearance was frozen, the team came back to the US for the prototype build, system tests and launch stages.

Nevertheless, by 2003 the NA OEM refreshed the product by changing hood, fenders, grill, fascias, tailgate, headlamps and tail lamps, and the entire interior. This project was conducted entirely in the USA for both activities of Styling and Engineering for the NA OEM brand vehicle, but the Japanese partner company (JPC) was in charge of designing and engineering the differentiation components for their brand. This required development of hood, fascias, fenders, head lamps, tail lamps, appliques and badges for the car exterior while the interior was kept carryover from the NA OEM model with only small obvious “badge engineering” changes. Since the product was going to be tested, manufactured and sold in the US, the JPC used its California based Design Studio, and its engineering operations in Japan.

According to a member of the program management team for both projects, the fact that the hard points were frozen in the NA OEM model by the time the JPC came on board, gave a lot of freedom to the Styling activity to know what was feasible to do and only focused on moving certain styling lines and color finishes to make the product of their brand match better their DNA.

In order to engineer the product, the JPC had access to the latest mature CAD information from the NA OEM that showed all packaging and functional constraints that had been solved by the US based team and only surfaced around them. In the case of the fender all attachment points were already defined thus the only changes were to redefine the headlamp edge to the new appearance and to add a character line to provide line continuity between the wheel lip and the new image of the fascia. The grill was left open as the JPC DNA required without deteriorating engine cooling performance and the hood just showed new character lines to provide continuity to the opening. The tail lamps only changed in the internal graphics and color distribution. Given that the project scope only involved small packaging changes, most of the information was already available for the California Studio to quickly surface it. This also helped the engineering activity to work straight on solids rather than in sections, and to focus on packaging, manufacturability and timing.

Although there were many advantages that made the tophat variant development to run smoothly, it is important to highlight that many customers seem to perceive little or no differentiation at all between the brands for this products. However, it is still successfully sold for both brands up to date.

### *5.1.3 Compact vehicle variant: Interaction between NA OEM Design Studio, EU Engineering and Mexico Engineering*

In 2008, a new derivative from a tophat under development was started to be styled in the NA OEM Design Studio and engineered in the Mexican subsidiary of the NA OEM (MEX OEM). Additionally

the platform and the base tophat that provided all the hard points and functional constraints were being developed in the European subsidiary of the NA OEM (EU OEM). The base program, which was in charge of the co-located development of the mainstream product was two years ahead in the Product Development Process and thus had much of the engineering information already developed and available.

The project scope was to have a series differentiation between the mainstream brand and the next upscale brand of the NA OEM. To achieve this, only new headlamps, fascia, grill, hood, tail lamps and deck lid were styled and engineered. Nonetheless, the Studio intent demanded a few changes in the front end architecture given that additional headlamps and hood appliques were included in the program content. This posed the need to re-develop some of the functional information available in order to execute competitive margins and flushness with more content, redefining locating and attaching strategies. Interior was intended to be completely carried over with only small modifications in the badges and color finishes.

To execute this project the MEX OEM engineering team moved to the US for most of the feasibility process to have a clear communication of the design intent and clear response to the co-located executive stakeholders for any potential change in product image. However, most of the CAD work was done in Mexico, working the functional and platform CAD information from the base program that was maintained up-to-date in the corporate CAD repository. The Studio CAD information was also uploaded into such repository and then fed back in section form to approve feasibility or provide changes.

One of the program management team members recalls: "It was very useful to always have someone from the MEX OEM team here in case there were new surfaces available. Even if it was not the responsible engineer, he knew the Mexican organization very well, which helped him to know quickly who to call to solve any issue. He was able to walk into the Studio to review the surfaces even before they were milled to the clay to assess if the new surfaces achieved engineering direction or otherwise, he could communicate clearly in native, engineering and organizational languages with the lead engineer to assess. One issue that we did encounter was the fact that sending very 'raw' design intent involved confidentiality risks, especially recently that the company has had major 'leaks' of information about styling intent to the media. They are always trying to catch how the future vehicles will look like. So the information exchange for detailed renders and clay models is something that we always manage face-to-face. I believe there is not a great need for this detailed information to be shared with engineering for them to develop the product but being close to the clay is very motivating for the team. I have come to notice that actually seeing what you are

designing helps understand the importance of each character line and of the entire appearance. Having the engineers actually liking the vehicle they are designing encourage them to avoid changing the Studio intent and motivates them to look for more solutions to avoid changes.”

#### *5.1.4 Current distance interaction project between US OEM and European subsidiary*

Early in 2009 the OEM under study decided to start leveraging their global assets to develop a tophat using its subsidiary in Europe to lead the legacy platform components and styling activities together with its US based in-house Body Engineering team. This is, all clay models and surfacing work would have to be conducted in a different location from the CAD and CAE development, functional stakeholders, program management team and many key executive decision makers. Marketing team was also meant to be spread throughout the world as this product was intended to be truly global.

As it has been stated above, this had been a breakthrough for this company, as most of the program team members in the US based team had not had the chance to work in this type of projects, mainly because both organizations had always been independent to develop their local products. More specifically, the US Engineering team had always had the support of their local Design Studio and all the co-location benefits of this situation. The challenge now was to develop the same product with very different functions at different locations and even different time zones.

The Design Engineering supervisor in charge of this project describes his experience as follows:

The information was very difficult to communicate, there was a lot of noise in the system that did not allowed us to develop the product in the same way. Nevertheless, even though everybody knew that information was slower to move between teams, the project timeline did not change compared to that of a co-located project.

Much of the noise that seemed to be rather different from our normal everyday interaction with the US team was derived from the lack of immediate response when an issue was detected. In a regular program, I can be reviewing the model with the designer and whenever we believe there may be an issue to execute a styling line, we just call the engineer and he or she would come into the studio and quickly assess whether if a proposal is feasible or not. The same happened when the Body Engineering team did not find a way to properly execute a surface; they can quickly setup a meeting with the Design Engineer and get not only quick feedback of what would be acceptable, but also work together to achieve a solution that satisfies both. In this program, meetings have to be pre-scheduled with some anticipation because the parties are not necessarily available. This situation is

worsening in time because time slots get quickly booked in all team members' agendas and it is virtually impossible to set up an urgent conference call. We were no longer able to use the old way of walking to a desk, get what you need and go back to the board.

Also, information requires a lot of preparation prior to the meeting, since the windows in which we can communicate are quite narrow, both engineers and designers are often loath to release less than perfect information to avoid ambiguity or additional lengthy iterations. Even the communication channel is cumbersome! In a "regular" program I would only need a pencil and piece of paper to finalize and to agree on a proposal face to face. Within a distant team I need to prepare a section in CATIA, thoroughly annotate it, upload it and wait for it to tessellate, pre-schedule a meeting, connect to WEBEX and then start explaining the problem. All this provided that all the parties actually call into the meeting and do so on time. During the meeting, there are many different factors that normally affect communication, mainly language barriers and lack of expertise using Netmeeting or WEBEX. If there was something not acceptable for someone, information to communicate the concern back was not necessarily prepared, so feedback had to be limited to a verbal description as accurate as possible of a counter proposal or in some cases a follow-up review to give chance to the stakeholder to appropriately prepare his or her information. Also there are the normal non-technical factors affecting conference call such as a person coming to your desk to ask a quick question, your other phone ringing or an important e-mail arriving. All that is noise and reside in all parties.

I can say that distance interaction has been more time and effort consuming than a co-located program, but I am also convinced that this will become the new way of doing business in our company and in the industry.

Also, although we all belong to the same company and use the same PDP to calculate project timelines and measure progress, the way we understand and execute the process locally produces also a lot of noise. It seemed that there are two different and equally powerful companies trying to adapt to the other's way of doing business. This was apparent during the feasibility process of this program.

US based Body engineers have lost much of their systems engineering view for component and surface changes as they have been specializing into high performance components. This is something that their European counterparts have not lost, thus Design Studio has more freedom to explore different styling alternatives. One good example happened when we tried to change the theme to accommodate the windshield wiper blade to use a single motor instead of a dual motor



sub-system. This proposal would improve aesthetics by having just one blade to hide behind the hood, as well as reduce cost by deleting the additional motor. Obviously this proposal would impact importantly on the styling surfaces. When this concept was initially presented, the engineering team only took into account the change in the windshield angle at zero cost since it was going to be brand new anyway. However the Design Engineering group had to make the assessment for the integration of the surfaces. This is, we are responsible to understand the impact of a surface change in the rest of the vehicle surfaces. The change in the windshield to accommodate the new wipers would involve changing A-pillar angles, which in turn will require changes in the interface to the instrument panel main substrate. Additionally the new angle would have to reposition the ceramic paint line all along the perimeter of the windshield, this paint is particularly important to avoid sunlight washing out the center stack navigation screens and chromed accents. The screens positions would then have to change and the chromed accents deleted, and since the driver location did not change, it was very likely that all functions displayed would end up being out of hand reach for the smallest population percentile or obstructed by the steering wheel. This is obviously a major quality and styling hit that nobody wanted to take. Furthermore, the windshield angle change posed major changes to the former platform HVAC and ductwork to achieve an energy-efficient defrosting system along with the need to tint the rear windows to avoid blinding sunlight reflecting on the repositioned screen. All the engineering and styling hours that would be required to re-design, prototype and test all these sub-systems would have easily off-set the cost of the saved motor.

It is very rare that a wiper engineer has the vision of all the changes that one component will drive to the entire vehicle. It is also rare that either the screen or the HVAC engineer attends a meeting in which a headlamp or a wiper will be discussed. Moreover, the fact that it happened in this specific vehicle does not mean that it will happen always as vehicle appearance (i.e. form factor) varies. It would be unreasonable to have 200 engineers looking at every change impact on this extremely tied system: the vehicle. It takes seasoned experts to take accountability for any styling change or any engineering proposal that impacts surfaces. Design Engineering takes that systems integration role.

Surprisingly, the European organization lacks this function, and is still capable of delivering a very good product by communicating directly between designers and Body engineers. I believe this is due to the larger systems engineering role that each engineer plays, delegating the detailed component design work to a FSS. It is therefore very complicated to have both organizations work when engineers in one are used to do so in an isolated way relying on a system integration guardian while the others are used to communicate often and solve more problems in cross functional teams.

One other important factor is the timing at which organizations are meant to freeze data. In NA we are used to make a well defined cut-off to understand engineering implication of appearance intent in time. All sections are frozen and fed to EMM's to develop surfaces for the milestone. In EU that process is more relaxed and information flows all the time in a work in progress fashion. In contrast, Body Engineering in the US cannot work with WIP information. In the last US co-located program on which I participated, each engineer was developing components from different level of surfaces; some were doing it from a pre-FC4 release, some from FC4 and some others from even pre-FC5. When we got the data for virtual validation, parts were not compatible, this means that some parts crashed into others, or held large and uneven margins. The latest engineering data did not resemble in any way neither the last frozen clay model nor the latest virtual surface release. This is again a consequence of the lack of communication between highly specialized teams. During the distant program, this difference in working methods brought an important shortage of resources, because the engineering team waited until the cut-off to provide information in sections. Then the EMM team was insufficient to develop new surfaces for the entire vehicle with this large peak of requests. This brought delays in surface delivery dates and lack of precision in the changes, increasing the friction and the number additional meetings for clarification.

A body engineer working in the same program remarked:

In the case of distance interaction, local priorities and idiosyncrasies delayed the sense of urgency and important information could take days to arrive. There is a deep perception that our requests are being ignored or simply done with a different sense of urgency than we would, especially because the program and company leadership is local to us, and they demand answers fast. Moreover, we started to get questions and requests for specific colors on parts that we did not know of, that is when we realized that the clay model that upper management was reviewing, differed from what we were engineering. Design Studio was surfacing and milling proposals that engineering had not got approved by the program in terms of cost and quality targets or even the functional management. And we had no way to know that the theme being engineered was, to some extent, an alternate theme. It was not the preferred and cost assumed choice. Thus there was a perception that Design Studio will hold information until the management buys it off without knowing the feasibility implications of what they are approving. After it is approved, there is a large amount of pressure over Engineering to deliver what was presented and glamorously shown without deviating from the booked targets. This course of action burns a lot of non-engineering hours just to try to explain the reasons for the lack of feasibility of the new request.

## 5.2 Analysis of lessons learnt

Upon revision of the past projects undertaken with distance interaction between Design Studio and Engineering, important factors to consider arise.

### *5.2.1 Governance factors*

Since the OEM under study is based in the US, every time that a product is going to be developed for the US market, there has to be interaction with the US based organization to share information on the vehicle appearance to support market research efforts in order to ensure successful product acceptance. Additionally, it has been noticed that the top management for both NA and Global operations, residing in Detroit, must have fast access to the clay model that reflects the latest level of vehicle appearance. Thus, the US Design Studio team is always supporting this modeling effort for any product sold in the US, regardless of where the lead design or lead engineering activities are located.

Also, the decision making process can be difficult to manage. For all the cases reviewed, there was always a local resident in charge of addressing potential changes to the appearance derived from upper management and theme research review of the clay model. That resident was the champion to communicate information from styling to the Engineering team and to explain to the upper management the engineering rationale behind some characteristics in the models that could potentially be requested to change.

### *5.2.2 Organizational factors*

It is then apparent that the US OEM has important experience executing distant projects that resulted in successful products. It is also important to note that all of these projects were undertaken with foreign Engineering organizations namely the JPC and the EU OEM. None of the distant interaction projects were undertaken by the US based Engineering team and a foreign Design Studio organization but were supported by the US based Design Studio. Therefore US Studio organization is experienced in this framework. The interfaces identified in the DSM have been useful to communicate design intent to Engineering while the Design Engineering activity helps the appropriate information preparation before it is shipped to the Stylist inside the Studio.

### *5.2.3 Communication (Accuracy of information) factors*

Information tends to be more accurate when both Design Studio and Engineering are co-located given the inherent asynchronous nature of the communication. We can identify four basic elements

that are the basis for the whole communication process: the channel, the message, the source and the receiver (Aguirre, 2006). In the case of this specific kind of interaction, the message seems to be the most problematic component to manage. Every time the information is inaccurate it takes longer for the source to know that the receiver has problems understanding it. Although the channels such as CAD information seem to be the same whether a program is managed locally or from the distance, the fact that the source and the receiver have the option of seating in front of the same information and speak the same language (organizational, functional and native) helps to solve the surface problems faster.

The fact that the message must be shipped through a unique channel in the corporate repository of CAD information, poses additional churn than that of a co-located program. Sections must be clearly marked-up and there must be conference calls with the co-located team to be aware of the information that are to receive.

It is also important to highlight that the fact that the engineering team has been co-located in these projects has posed an important advantage to improve the information preparation before sending it to Studio. In general many surface issues result from lack of appropriate collaboration between engineers to explain functional content or resolve packaging, attaching, cost or quality concerns more than with designers, both distant and co-located project engineers have troubles managing work-in-progress (WIP) information, because engineers don't talk to each other.

#### *5.2.4 Process differences*

Since these programs have been undertaken by overseas Engineering organizations, their PDP approach to the corporate PDP has been used. Our interviewees expressed that the disciplined process followed by the JPC helped reduce the need to share more information derived from late changes. Also the fact that the JPC approved, tested and used design guidelines to provide feasibility helped to build better quality products.

Additionally, the EU OEM is more prone to have a more fluid communication between Engineering and Studio while the US OEM establishes a defined date for engineering cut-off. This results in a big overflow of information in a much reduced time, therefore the surface modelers have to work extra hours to process all the information and there is limited time to clarify ambiguous information. This process is more prone to have Studio releasing inaccurate information, forces to have long periods of low utilization of the surface modeling capacity and sudden peaks of utilization immediately after Engineering cut-off.

Moreover, each surface release should then be the output of a thorough engineering review. When teams are co-located, it is more common that the US based engineering team uses the new surface release to identify packaging or functional problems, instead of doing so up-front. Also, there are many system level issues that can be created after changing an individual component and are discovered until the surfaces for the entire vehicle are released. This is a reason why US based Engineering teams struggle when they need to interact from the distance with their “system level performance testing entity”. The overseas organizations tend to identify component and system integration issues before surface release. Then they communicate the problem through sections. This helps the feasibility process to move forward and reduce iterations.

# Chapter 6

## Conclusions

It is important to acknowledge that there is a large amount of information that must be processed at ECO within the Design Studio. Most of the time, feasibility sections are fed from BE at the very last minute for most SDC's. In order to create value by avoiding major modifications to the theme to fulfill engineering feasibility information, Designers require having a very creative, intensive and thus inspirational course of action. Therefore, Designers prefer to receive information in a more periodical fashion.

The impact of such interfaces can be mitigated through two main approaches:

- Reduce the need for the communication interface by bringing as many of the stakeholders to the LCC subsidiary as possible but keeping modularity and leveraging platform knowledge based mindset to provide feasibility back to the Design Studio.
- Improve the communication for those interfaces that still require it by creating appropriate interfaces for the communication process such as co-located Design Engineers and Systems Engineers in a spoke and hub fashion and defining the skill set required and capable of managing and translate differences in expectations

The value proposition that supports the hypothesis states that low cost countries with mature engineering capabilities do not need to have a co-located Design Studio to engineer a vehicle tophat. In fact, there is more value generated when the Design Studio is close to the market to which the target customer belongs.

From the review of both Studio Designed Components (SDC's) and the generic top hat project structure, the functional teams within Body Engineering (BE) that engineer most of the vehicle top hat are:

| <b>Sub-system</b>      |
|------------------------|
| Instrument Panel       |
| Console                |
| Exterior Ornamentation |
| Hard Trim              |
| Electrical             |
| Seats                  |
| Door Trim              |
| Sheet Metal            |
| Headliner              |
| Fascias                |
| Lighting               |
| Steering wheel         |
| Closures               |
| Glass                  |
| Soft Trim              |
| Power train            |
| Exterior Systems       |
| Wheels                 |
| Carpet                 |
| Brakes                 |

Therefore, these are the key areas of technical development of expertise for detailed in-house engineering of tophats. Any subsidiary organization willing to achieve such capacity must have access to design rules and specifications that define component and system level performance as well as being savvy in common and added value manufacturing processes of this commodities prior to the feasibility process in order to avoid additional iterations derived from lack of expertise.

Upon analysis of the DSM, we find that the PDP is decoupled into two main loops:

- Design Studio Process loop
- Concurrent engineering loop

The latter is the most important set of processes for any subsidiary organization to develop “tophat engineering capability” given that the main functional teams that lead the execution of these

activities are identified. Nevertheless, there are two functional activities that are outside of the scope of the subsidiary organization:

- Executive Decision makers. - There will ways be a need to keep them informed of the status of cost, quality and as a result the status of the feasible appearance under these constraints. There is also a need to have a model close to the executive decision makers. A physical model has been historically preferred in all legacy programs to avoid misconceptions of the design intent.
- Styling. - Every engineering change that cannot be contained within the latest surfaces must be surfaced by the Styling team (designers and math modelers) upon receipt of the engineering proposal or communication of the functional constraints. As the value proposition states, the main source of styling intent information comes from close interaction of stylists with target customer and their environment. This is normally done in non low cost countries (non-LCC's). Therefore it is understood that there will be geographical separation in this communication process.

From the DSM analysis, we find that the activities that Styling performs in the Product Development Process (PDP) are:

- Initial Part Breakdown definition
- Initial Color and Materials intent
- Update to occupant and mechanical packaging
- Surface change in 3D models and feasibility clay
- Final surface release
- Final Color and Material direction

Most of these activities are clearly communicated through documents and standards. Nonetheless, the Surface change in 3D models is the only one that clearly needs to be worked iteratively. From the analyses of the communication mechanisms that available in the sponsored company as well as the lessons learnt from past programs. We identified the main roadblocks to perform the top hat engineering capability activities:

First, time zone differences have been constantly identified as important for communication. The fact that different offices work asynchronously delays the appropriate issue resolution and discourages the use of virtual communication tools that foster synchronous information exchange such as WEBEX and Netmeeting.



In this sense, different from a co-located project, the implicit asynchronous nature of the distant interaction creates additional workload to prepare information prior to the transfer. Although the formal information mechanisms such as feasibility sections are the same for distant a co-located projects, there are many informal mechanisms of communication that need to happen prior to Engineering cut-off and sections release. Clarification of potential alternatives of execution and their impact in theme must be constantly communicated before reaching an agreement to release sections for surfacing. This requires preparation of visual and accurate proposals, appropriate transferring channels and high commitment in honor schedules of communication.

One alternative to address this resides in the Design Studio's willingness to accept and style post-cut off information. This is essential to avoid additional iterations. Hence, constant communication between the Design Engineers co-located in the engineering site and the Design Engineers co-located in the Studio is crucial. Alternately, visual information must be prepared to constantly communicate and agree upon the better solution. Co-located programs normally do this face-to-face in front of an image of the theme, several sheets of clean paper and the entire team around providing feedback. Upon revision of these operations, it is important that both organizations, the Design Studio lead and the Engineering lead, have appropriate technology enablers to replicate this processes. Touch screens and conferencing tools must be used in both sides to improve informal communication prior to Engineering cut-off.

Second, there is an important lack of systems engineering view in the BE team. The organizational setup of the US OEM incentivizes the optimization of components performance. Nevertheless, in many cases a surface change affects complete vehicle performance and therefore other components. It is imperative that the Design Engineer takes the role of system integrator from the surface perspective, this is, they must be aware of all the potential surface changes derived from the informal communication processes, understand the implication to surfaces of other components, and lead the resolution that best accomplishes vehicle performance of attributes, cost and quality. The successful achievement of this discipline will allow the design to move forward and reduce the amount of formal and informal information that needs to be communicated. As leaders of distant interacting teams, it is expected that initiative to proactively address potential risks down the road is an inherent characteristics of these individuals.

Third, it is apparent that the fact that information takes longer to be transferred than in a co-located project, the timelines and budgets must be provisioned in advance to account for this cost risk.

Finally, styling driven changes in the tophat components architecture is common and reduces the usefulness of re-using the legacy program information. This is, part breakdown derived from the new theme and different content will change the engineering solutions to the styling proposal. The system architecture comparison must be done early enough to minimize its impact and maximize understanding of the re-usable information. In the same way that Toyota does, it is important that all subsidiaries standardize and share the knowledge of certain aspects of vehicle geometry.

Similarly, we identified the following best practices in past programs of derivatives and tophat developments:

First, the fact that the subsidiary organization in a LCC shares the time zone with the Design Studio increases the time window for synchronous collaboration and its expected time to provide awareness, and joint development of solutions during the feasibility stages.

Second, the use of liaison engineers that report to the organization with ownership of styling responsibility. These professionals should understand the native language and culture of the engineering organization and have organizational incentives similar to the Design Studio point of view to avoid future rejections. The intent is to increase the willingness to provide and accept ambiguous information between organizations and thus decrease the noise in the communication process.

Third, there must be daily information exchange between the Engineering organization and the Design Studio to communicate any issues that would impact styling. Studio must be aware in advance of the changes that they will need to address, to avoid ambiguity.

In this sense, it is important that the systemic issues had been resolved prior to their communication to the studio, to avoid any additional re-work that will require additional information exchange.

Fourth, the use of models at both locations is required. It is important that both activities are aware of the latest styling status. Also as stated above, it is important to communicate this intent to the executive decision makers to have prompt feedback on overall latest appearance status; this is normally done by having a “living” clay that is constantly milled back to the latest design intent. Virtual models have proven to be useful at the early stages of the feasibility process, however as the surface and finishes are detailed into the design, a hard model is important for the stylists to communicate the detailed execution intent to the Engineering team. Therefore, the Engineering team must be present to review this communication instrument to transfer that intent into the production parts.

However, it is important to mention that the most difficulties to propose and address surface changes do not lie in the ability of teams to stare at information on a screen. Current technological tools enable sharing tacit information easily between both co-located and distant teams. The pre and post review processes are the ones that pose the more problems to transfer coordination information.

In addition, access to the model, mostly physical, is important as a motivational and team integration tool to enhance collaboration among engineers in which everyone works towards the same goal. In the words of Peter Ratz, BMW manager responsible for the technology interface between Design Studio and Engineering, “nothing takes the place of seeing the real thing.”

Fifth, periodical face-to-face meetings are also important to improve the willingness to accept ambiguous information and to reduce the effects of the “not-invented here” syndrome by enhancing the team identity.

Sixth, similar to the JPC, the use of a disciplined approach to the PDP that minimized late styling driven changes has proven to be effective to reduce the need to exchange information as the design progresses. Also, it improves product quality since the engineering time is used to optimize designs rather than to re-design.

Seventh, the re-use of information from previous tophats from the same platform provided a lot of freedom to build new tophat variants. Nevertheless, this has only been executed in small scalability projects (“face-lifts”) but as mentioned before, it is key for the success of a front loaded PDP, especially when teams are not co-located in which the information transfer process must be leaner.

In addition, appropriate workforce management should encourage the specialization of Body Engineers and Design Engineers in the design phase of the development within a certain platform. This would allow carrying over the knowledge of specific sections and hard points of previous tophat build from the same platform.

New vehicles from completely new platforms are normally developed in a co-located fashion and over longer periods of time. Therefore, the quality of the design feasibility solutions is expected to be optimal. A tophat development thus implies that there has been at least one previous vehicle design from the same platform that had undergone the feasibility process and its information must be available in the corporate CAD repository. The use of an in-house engineering approach enables a seamless information transfer from the legacy program solutions, different from previous approaches in which Full Service Suppliers did not share complete feasibility information. This reduces the

amount of time that is needed to provide feasibility to component surfaces and focuses the feasibility process in the system integration and attributes delivery.

THIS PAGE IS INTENTIONALLY LEFT BLANK

# Appendix

## Appendix A: Examples of platforms and tophats from different OEMs

(Automobile platform, 2010)

### Platform and Tophats of GM

| Platform | Vehicle Type               | Tophats     |             |                 |          |            |          |          |         |        |          |         |  |
|----------|----------------------------|-------------|-------------|-----------------|----------|------------|----------|----------|---------|--------|----------|---------|--|
|          |                            | Chevrolet   | Pontiac     | Oldsmobile      | Buick    | Cadillac   | Saturn   | Geo      | GMC     | Opel   | Daewoo   |         |  |
| M-body   | subcompact                 | Sprint      |             |                 |          |            |          |          |         |        |          |         |  |
|          | subcompact                 | Metro       | Firefly     |                 |          |            |          | Metro    |         |        |          |         |  |
| GM4200   | subcompact                 | Celta       |             |                 |          |            |          |          |         | Corsa  |          |         |  |
| Gamma    | subcompact                 | Aveo        | G3          |                 |          |            |          |          |         |        |          |         |  |
|          | compact                    | Citation    | Phoenix     | Omega           | Skyhawk  |            |          |          |         |        |          |         |  |
| X-body   | compact                    |             | 2000        |                 |          |            |          |          |         |        |          |         |  |
|          |                            |             | J2000       |                 |          |            |          |          |         |        |          |         |  |
|          |                            |             | Sunbird     |                 |          |            |          |          |         |        |          |         |  |
|          |                            |             | Sunfire     | Firenza         | Skyhawk  | Gimarron   |          |          |         |        | Ascona   | Espero  |  |
| N-body/  | compact                    | Beretta     |             | Cutlass Calais  | Skyhawk  |            |          |          |         |        |          |         |  |
| L-body   |                            | Corsica     |             | Achieva         | Somerset |            |          |          |         |        |          |         |  |
|          |                            | Malibu      | Grand Am    | Cutlass         |          |            |          |          |         |        |          |         |  |
| P-body   | compact                    |             |             |                 |          |            |          | Storm    |         |        |          |         |  |
|          |                            | Spectrum    |             |                 |          |            |          | Spectrum |         |        |          |         |  |
| T-body   | compact                    |             | LeMans      |                 |          |            |          |          |         | Kadett | LeMans   |         |  |
|          |                            |             |             |                 |          |            |          |          |         | Astra  | Cielo    |         |  |
|          |                            |             |             |                 |          |            |          |          |         | Zafira |          |         |  |
| Delta    | compact sedan/MPV          | Cobalt      | Pursuit/G4  |                 |          |            |          | Ion      |         |        | Astra    |         |  |
|          |                            | Cruze       | G5          |                 |          |            |          | Astra    |         |        | Zafira   |         |  |
|          |                            | HHR         |             |                 |          |            |          |          |         |        |          |         |  |
|          |                            | Orlando     |             |                 |          |            |          |          |         |        |          | Lacetti |  |
|          |                            | Prizm       |             |                 |          |            |          |          |         |        |          |         |  |
| S-body   | compact                    | Nova        | Vibe        |                 |          |            |          | Prizm    |         |        |          |         |  |
| A-body   | mid-size                   |             |             | Cutlass Ciera   |          |            |          |          |         |        |          |         |  |
|          |                            |             |             | Cutlass         |          |            |          |          |         |        |          |         |  |
|          |                            | Celebrity   | 6000        | Cruiser         | Century  |            |          |          |         |        |          |         |  |
|          |                            | Lumina      |             | Cutlass Supreme | Regal    |            |          |          |         |        |          |         |  |
| W-body   | mid-size                   | Monte Carlo |             | Intrigue        | Century  |            |          |          |         |        |          |         |  |
|          | mid-size                   | Impala      | Grand Prix  |                 | LaCrosse |            |          |          |         |        |          |         |  |
| GM2900   | mid-size                   |             |             |                 |          |            | L-Series |          |         | Vectra |          |         |  |
| Epsilon  | mid-size                   | Malibu      |             |                 | Regal    |            |          |          |         |        | Vectra   |         |  |
|          |                            | Malibu Maxx | G6          |                 |          | LaCrosse   | BLS      | Aura     |         |        | Insignia |         |  |
| H-body/  | full-size                  |             |             | Eighty-Eight    | LeSabre  | Deville    |          |          |         |        |          |         |  |
| G-body/  |                            |             |             | Ninety-Eight    | Electra  | Seville    |          |          |         |        |          |         |  |
| C-body/  |                            |             |             | Aurora          | Avenue   | DTS        |          |          |         |        |          |         |  |
|          |                            |             |             | K-body          | Riviera  |            |          |          |         |        |          |         |  |
| E-body/  | personal luxury            |             |             | Lucerne         | Riviera  | Eldorado   |          |          |         |        |          |         |  |
| V-body   |                            |             |             | Toronado        | Reatta   | Allante    |          |          |         |        |          |         |  |
| Theta    | compact/midsize            | Equinox     |             |                 |          |            |          |          |         |        |          |         |  |
|          | crossover SUV              | Captiva     | Torrent     |                 |          | SRX        | Vue      |          | Terrain | Antara | Winstorm |         |  |
| U-body   | minivan/mid-size crossover | Lumina APV  | Trans Sport |                 |          | Terraza    |          |          |         |        |          |         |  |
|          | SUV                        | Venture     | Montana     |                 |          | Rendezvous |          |          |         |        |          |         |  |
|          | full-size                  | Uplander    | Aztek       | Silhouette      |          | GL8        | Relay    |          |         | Sintra |          |         |  |
| Lambda   | crossover SUV              | Traverse    |             |                 | Enclave  |            | Outlook  |          | Acadia  |        |          |         |  |

## Platform and Tophats of GM (continued)

| Platform                     | Vehicle Type                        | Chevrolet   | Pontiac    | Oldsmobile        | Buick      | Cadillac        | Saturn  | GMC              | Hummer | Opel               | Holden                 |
|------------------------------|-------------------------------------|-------------|------------|-------------------|------------|-----------------|---------|------------------|--------|--------------------|------------------------|
| H-body                       | subcompact                          | Vega        | Astre      |                   |            |                 |         |                  |        |                    |                        |
|                              | coupe                               | Monza       | Sunbird    | Starfire          | Skyhawk    | -               | -       | -                | -      | -                  | -                      |
| T-body                       | subcompact                          | Chevette    | T1000      | -                 | -          | -               | -       | -                | -      | Kadett             | Gemini                 |
| Kappa                        | subcompact/<br>roadster             | -           | Solstice   | -                 | -          | -               | Sky     | -                | -      | GT                 | -                      |
| Y-body/<br>Z-body            | compact                             | Corvair     | LeMans     | Cutlass           | Skyhawk    | -               | -       | -                | -      | -                  | -                      |
| X-body/<br>K-body            |                                     |             | Ventura    | Phoenix           | Omega      | Apollo          | Seville | -                | -      | -                  | -                      |
| A-body/<br>G-body            | compact                             | Malibu      | Tempest    | Cutlass           | Special    |                 |         |                  |        |                    |                        |
|                              |                                     | Chevelle    | Grand Prix | Supreme           | Century    |                 |         |                  |        |                    |                        |
|                              |                                     | El Camino   | LeMans     |                   | Regal      |                 |         |                  |        |                    |                        |
|                              | mid-size                            |             | Bonneville |                   |            |                 |         | Caballero        |        |                    |                        |
| V-body                       | mid-size/<br>full-size              |             |            |                   |            |                 |         |                  |        | Commodore<br>Omega | Commodore<br>Statesman |
|                              |                                     |             | GTO        |                   |            | Catera          |         |                  |        |                    | Monaro                 |
| Sigma                        | mid-size/<br>full-size<br>sedan/SUV |             |            |                   |            | CTS             |         |                  |        |                    |                        |
|                              |                                     |             |            |                   |            | STS             |         |                  |        |                    |                        |
|                              |                                     |             |            |                   |            | SRX             |         |                  |        |                    |                        |
| Zeta                         | mid-size/<br>full-size              | Camaro      | G8         |                   |            |                 |         |                  |        |                    | Commodore<br>Statesman |
| B-body/<br>C-body/<br>D-body | full-size                           | Impala      | Bonneville | 88                | LeSabre    | DeVille         |         |                  |        |                    |                        |
|                              |                                     | Caprice     | Catalina   | 98                | Electra    | Fleetwood       |         |                  |        |                    |                        |
|                              |                                     | Parisienne  |            | Custom<br>Cruiser | Estate     | Brougham        |         |                  |        |                    |                        |
|                              | full-size                           |             | Safari     |                   | Roadmaster |                 |         |                  |        |                    |                        |
| E-body                       | personal luxury                     |             |            |                   | Riviera    |                 |         |                  |        |                    |                        |
| F-body                       | GT coupe                            | Camaro      | Firebird   |                   |            |                 |         |                  |        |                    |                        |
| Y-body                       | sports car                          | Corvette    |            |                   |            | XLR             |         |                  |        |                    |                        |
| GMT300                       | compact/<br>mid-size pickup         | S10         |            |                   |            |                 |         | S15              |        |                    |                        |
| GMT355                       |                                     | SSR         |            |                   |            |                 |         | Sonoma<br>Canyon |        |                    | Colorado               |
| GMT800/<br>GMT900            | full-size<br>pickup/crossover       | Silverado   |            |                   |            | Escalade<br>EXT |         | Sierra           | H2 SUT |                    |                        |
|                              | compact SUV                         | Tracker     | Sunrunner  |                   |            |                 |         | Tracker          |        |                    |                        |
| GMT300/<br>GMT360            | mid-size SUV                        | Blazer      |            | Bravada           | Rainier    |                 |         | Jimmy            | H3     |                    |                        |
| GMT800/<br>GMT900            | full-size SUV                       | TrailBlazer |            |                   |            | Escalade        |         | Yukon            | H2     |                    |                        |
| M-body                       | minivan                             | Tahoe       |            |                   |            |                 |         | Safari           |        |                    |                        |
| GMT600                       | full-size van                       | Astro       |            |                   |            |                 |         | Savana           |        |                    |                        |
|                              |                                     | Express     |            |                   |            |                 |         |                  |        |                    |                        |

## Platform and Tophats of Ford

| Platform    | Type       | Dates      | Tophats                     |
|-------------|------------|------------|-----------------------------|
| Panther     | full-size  | 1979-      | Ford Crown Victoria         |
|             |            |            | Mercury Grand Marquis       |
|             |            |            | Lincoln Town Car            |
|             |            |            | Ford Police Interceptor     |
|             |            |            | Mercury Marauder            |
|             |            |            | Ford Country Squire         |
|             |            |            | Mercury Colony Park         |
|             |            |            | Lincoln Continental Mark VI |
| CA11        | compact    |            | Ford Laser                  |
|             |            |            | Mercury Tracer              |
| CE14        | compact    | 1981-1994  | Ford Escort                 |
|             |            |            | Ford EXP                    |
|             |            |            | Ford Tempo                  |
|             |            |            | Mercury LN7                 |
|             |            |            | Mercury Lynx                |
|             |            |            | Mercury Topaz               |
| Fox         | compact    | 1978-1993  | Ford Mustang                |
|             |            |            | Ford Thunderbird            |
|             |            |            | Mercury Capri               |
|             |            |            | Mercury Cougar              |
|             |            |            | Lincoln Mark VII            |
|             |            |            | Lincoln Continental         |
|             |            |            | Ford Fairmont               |
|             |            |            | Mercury Zephyr              |
|             |            |            | Ford LTD                    |
|             |            |            | Mercury Marquis             |
| DN5         | mid-size   |            | Ford Taurus                 |
|             |            |            | Mercury Sable               |
|             |            |            | Lincoln Continental         |
| VN1         | minivan    | 1986-1997  | Ford Aerostar               |
| B           | subcompact | 1993 -2003 | Ford Fiesta                 |
|             |            |            | Ford Ka                     |
|             |            |            | Ford Puma                   |
| CT120       | compact    | 1989-2002  | Ford Escort                 |
|             |            |            | Mercury Tracer              |
| DA platform | compact    | 1986-1997  | Ford Aspire                 |
|             |            |            | Ford Festiva                |
| GD          | compact    | 1988-1992  | Ford Probe                  |
|             |            |            | Mazda 626                   |
|             |            |            | Mazda MX-6                  |
| C170        | compact    | 1998-      | Ford Focus                  |
| CDW27       | mid-size   | 1993-2006  | Ford Contour                |
|             |            |            | Mercury Mystique            |
|             |            |            | Ford Mondeo                 |
|             |            |            | Mercury Cougar              |



## Platform and Tophats of Ford (continued)

| Platform        | Type       | Dates        | Tophats             |
|-----------------|------------|--------------|---------------------|
| CDW27/CD16<br>2 | mid-size   | 1996-2000    | Ford Mondeo         |
| CDW27/CD13<br>2 | mid-size   | 2000-2007    | Ford Mondeo         |
|                 |            |              | Jaguar X-Type       |
|                 |            | 2001-2009    |                     |
| D186            | midsize    | 1986-2007    | Ford Taurus         |
|                 |            |              | Lincoln Continental |
|                 |            |              | Mercury Sable       |
| FN10            | midsize    | 1993-1998    | Lincoln Mark VIII   |
| MN12            | midsize    | 1989-1997    | Ford Thunderbird    |
|                 |            |              | Mercury Cougar      |
| SN-95           | compact    | 1994-2004    | Ford Mustang        |
| SA30            | compact    | 1989-1994    | Mercury Capri       |
| EA77            | full-size  |              | Ford Falcon         |
| EA169           | full-size  |              | Ford Falcon         |
| U2/U3           | SUV        | 1991-        | Ford Explorer       |
|                 |            |              | Mazda Navajo        |
|                 |            |              | Mercury Mountaineer |
| B3              | subcompact | 2004-current | Ford Fiesta         |
|                 |            |              | Ford Ka             |
|                 |            |              | Mazda Demio/Mazda2  |
|                 |            |              | Ford Ecosport       |
| C1              | compact    | 2003-current | Ford C-MAX          |
|                 |            |              | Ford Focus          |
|                 |            |              | Ford Kuga           |
|                 |            |              | Mazda Axela/Mazda3  |
|                 |            |              | Mazda 5             |
|                 |            |              | Mazda CX-7          |
|                 |            |              | Mazda MPV           |
| CD2             | SUV        | 2001-2007    | Ford Escape         |
|                 |            |              | Mazda Tribute       |
|                 |            |              | Mercury Mariner     |
| CD3             | mid-size   | 2003-current | Ford Edge           |
|                 |            |              | Ford Fusion         |
|                 |            |              | Mercury Milan       |
|                 |            |              | Lincoln MKX         |
|                 |            |              | Lincoln Zephyr/MKZ  |
|                 |            |              | Mazda CX-9          |
|                 |            |              | Mazda Atenza/Mazda6 |
| DEW98           | mid-size   | 2000-2006    | Ford Thunderbird    |
|                 |            |              | Lincoln LS          |
|                 |            |              | Jaguar S-Type       |

## Platform and Tophats of Ford (continued)

| Platform   | Type                      | Dates        | Tophats                  |
|------------|---------------------------|--------------|--------------------------|
| E8         | next generation full size |              | 2008 Ford Falcon         |
| EUCD       | mid-size                  | 2007-        | Ford Galaxy              |
|            |                           |              | Ford Mondeo              |
|            |                           |              | Ford S-Max               |
|            |                           |              | Volvo S80                |
|            |                           |              | Volvo V70                |
|            |                           |              | Volvo XC70               |
|            |                           |              | Volvo XC60               |
|            |                           |              | LR Freelander            |
| D2C        | sports                    | 2005-current | Ford Mustang             |
| PN105/106  | compact pickup            |              | Ford Ranger              |
|            |                           |              | Mazda B-Series           |
| P2/P3/P4   | full-size pickup          |              | Ford F-Series            |
|            |                           |              | Lincoln Blackwood        |
|            |                           |              | Lincoln Mark LT          |
| U2/U3      | SUV                       |              | Ford Explorer            |
|            |                           |              | Ford Explorer Sport Trac |
|            |                           |              | Lincoln Aviator          |
|            |                           |              | Mercury Mountaineer      |
|            | large SUV                 |              | Ford Expedition          |
|            |                           |              | Lincoln Navigator        |
|            | large SUV                 |              | Ford Excursion           |
| V2         | minivan                   |              | Ford Freestar            |
|            |                           |              | Mercury Monterey         |
| V184/V185  | mid-size van              |              | Ford Transit             |
| V227       | mid-size van              |              | Ford Tourneo             |
|            |                           |              | Ford Transit Connect     |
| VN         | full-size van             |              | Ford Club Wagon          |
|            |                           |              | Ford E-Series            |
|            |                           |              | Ford Econoline           |
| D3         | full-size                 | 1999-        | Ford Five Hundred        |
|            |                           |              | Ford Freestyle           |
|            |                           |              | Mercury Montego          |
|            |                           |              | Ford Taurus (2008+)      |
|            |                           |              | Mercury Sable (2008+)    |
|            |                           |              | Ford Taurus X            |
| EA169/E265 | full-size                 |              | Ford Falcon              |
|            |                           |              | Ford Territory           |

## Platform and Tophats of Chrysler

| Platform  | Years     | Vehicle Type          | Tophats                        |                |                 |                |               |
|-----------|-----------|-----------------------|--------------------------------|----------------|-----------------|----------------|---------------|
|           |           |                       | Chrysler                       | Dodge          | Plymouth        | Eagle          | Jeep          |
| <u>L</u>  | 1978–1990 | <u>subcompact car</u> | -                              | <u>Omni</u>    | <u>Horizon</u>  | -              | -             |
|           |           |                       |                                | <u>24</u>      | <u>TC3</u>      |                |               |
|           |           |                       |                                | <u>Charger</u> | <u>Turismo</u>  |                |               |
|           |           |                       |                                | <u>Rampage</u> | <u>Scamp</u>    |                |               |
| <u>K</u>  | 1981–1989 | <u>mid-size car</u>   | <u>LeBaron</u>                 | <u>Aries</u>   |                 | -              | -             |
|           |           |                       | <u>Town and Country</u>        | <u>400</u>     |                 |                |               |
|           |           |                       | <u>Executive</u>               | <u>Reliant</u> |                 |                |               |
| <u>E</u>  | 1983–1988 | <u>mid-size car</u>   | <u>New Yorker</u>              |                |                 | -              | -             |
|           |           |                       | <u>New Yorker Turbo</u>        |                |                 |                |               |
|           |           |                       | <u>E-Class</u>                 |                |                 |                |               |
| <u>S</u>  | 1984–1990 | <u>minivan</u>        | <u>Town and Country</u>        | <u>Caravan</u> | <u>Voyager</u>  | -              | -             |
| <u>G</u>  | 1984–1993 | <u>sports car</u>     | <u>Laser</u>                   | <u>Daytona</u> | -               | -              | -             |
| <u>H</u>  | 1985–1989 | <u>mid-size car</u>   | <u>LeBaron GTS</u>             |                |                 | -              | -             |
|           |           |                       | <u>LeBaron</u>                 |                |                 |                |               |
| <u>P</u>  | 1987–1994 | <u>compact car</u>    | -                              | <u>Shadow</u>  | <u>Sundance</u> | -              | -             |
| <u>J</u>  | 1987–1995 | <u>coupe</u>          | <u>LeBaron</u>                 | -              | -               | -              | -             |
| <u>B</u>  | 1988–1992 | <u>mid-size car</u>   | -                              | <u>Monaco</u>  | -               | <u>Premier</u> | -             |
| <u>C</u>  | 1988–1993 | <u>mid-size car</u>   | <u>New Yorker</u>              | <u>Dynasty</u> | -               | -              | -             |
| <u>AA</u> | 1989–1995 | <u>mid-size car</u>   | <u>LeBaron</u>                 | <u>Spirit</u>  | <u>Acclaim</u>  | -              | -             |
| <u>Q</u>  | 1989–1991 | <u>convertible</u>    | <u>TC by Maserati</u>          | -              | -               | -              | -             |
| <u>D</u>  | 1990–1994 | <u>compact car</u>    | -                              | -              | <u>Laser</u>    | <u>Talon</u>   | -             |
| <u>Y</u>  | 1990–1993 | <u>full-size car</u>  | <u>New Yorker Fifth Avenue</u> |                |                 | -              | -             |
|           |           |                       | <u>Imperial</u>                |                |                 |                |               |
| <u>AS</u> | 1991–1995 | <u>minivan</u>        | <u>Town and Country</u>        | <u>Caravan</u> | <u>Voyager</u>  | -              | -             |
| <u>LH</u> | 1993–2004 | <u>full-size car</u>  | <u>New Yorker</u>              |                |                 | -              | <u>Vision</u> |
|           |           |                       | <u>Concorde</u>                |                |                 |                |               |
|           |           |                       | <u>LHS</u>                     |                |                 |                |               |
|           |           |                       | <u>300M</u>                    |                |                 |                |               |
| <u>PL</u> | 1995–2005 | <u>compact car</u>    | -                              | <u>Neon</u>    | <u>Neon</u>     | -              | -             |
| <u>JA</u> | 1995–2000 | <u>mid-size car</u>   | <u>Cirrus</u>                  | <u>Stratus</u> | <u>Breeze</u>   | -              | -             |

## Platform and Tophats of Chrysler (continued)

| Platform | Years        | Vehicle Type         | Tophats                 |               |           |         |                    |
|----------|--------------|----------------------|-------------------------|---------------|-----------|---------|--------------------|
|          |              |                      | Chrysler                | Dodge         | Plymouth  | Eagle   | Jeep               |
| L        | 1978–1990    | subcompact car       | -                       | Omni          | Horizon   | -       | -                  |
|          |              |                      | -                       | 24            | TC3       | -       | -                  |
|          |              |                      | -                       | Charger       | Turismo   | -       | -                  |
|          |              |                      | -                       | Rampage       | Scamp     | -       | -                  |
| K        | 1981–1989    | mid-size car         | LeBaron                 | Aries         | -         | -       | -                  |
|          |              |                      | Town and Country        | 400           | -         | -       | -                  |
|          |              |                      | Executive               | -             | Reliant   | -       | -                  |
| E        | 1983–1988    | mid-size car         | New Yorker              | -             | -         | -       | -                  |
|          |              |                      | New Yorker Turbo        | -             | -         | -       | -                  |
|          |              |                      | E-Class                 | 600           | Caravelle | -       | -                  |
| S        | 1984–1990    | minivan              | Town and Country        | Caravan       | Voyager   | -       | -                  |
| G        | 1984–1993    | sports car           | Laser                   | Daytona       | -         | -       | -                  |
| H        | 1985–1989    | mid-size car         | LeBaron GTS             | -             | -         | -       | -                  |
|          |              |                      | LeBaron                 | Lancer        | -         | -       | -                  |
| P        | 1987–1994    | compact car          | -                       | Shadow        | Sundance  | -       | -                  |
| J        | 1987–1995    | coupe                | LeBaron                 | -             | -         | -       | -                  |
| B        | 1988–1992    | mid-size car         | -                       | Monaco        | -         | Premier | -                  |
| C        | 1988–1993    | mid-size car         | New Yorker              | Dynasty       | -         | -       | -                  |
| AA       | 1989–1995    | mid-size car         | LeBaron                 | Spirit        | Acclaim   | -       | -                  |
| Q        | 1989–1991    | convertible          | TC by Maserati          | -             | -         | -       | -                  |
| D        | 1990–1994    | compact car          | -                       | -             | Laser     | Talon   | -                  |
| Y        | 1990–1993    | full-size car        | New Yorker Fifth Avenue | -             | -         | -       | -                  |
|          |              |                      | Imperial                | -             | -         | -       | -                  |
| AS       | 1991–1995    | minivan              | Town and Country        | Caravan       | Voyager   | -       | -                  |
| LH       | 1993–2004    | full-size car        | New Yorker              | -             | -         | -       | -                  |
|          |              |                      | Concorde                | -             | -         | -       | -                  |
|          |              |                      | LHS                     | -             | -         | -       | -                  |
| PL       | 1993–2004    | full-size car        | 300M                    | Intrepid      | -         | Vision  | -                  |
| PL       | 1995–2005    | compact car          | -                       | Neon          | Neon      | -       | -                  |
| JA       | 1995–2000    | mid-size car         | Cirrus                  | Stratus       | Breeze    | -       | -                  |
| FJ       | 1995–2000    | coupe                | Sebring Coupe           | Avenger       | -         | Talon   | -                  |
| ST       | 2001–2005    | coupe                | Sebring Coupe           | Stratus Coupe | -         | -       | -                  |
| NS       | 1996–2000    | minivan              | Town and Country        | Caravan       | Voyager   | -       | -                  |
| JX       | 1996–2000    | convertible          | Sebring Convertible     | -             | -         | -       | -                  |
| JR       | 2001–2006    | mid-size convertible | Sebring Convertible     | -             | -         | -       | -                  |
|          |              | convertible          | Sebring Sedan           | -             | Stratus   | -       | -                  |
| PT       | 2001–present | compact car          | PT Cruiser              | -             | -         | -       | -                  |
| RS       | 2001–2007    | minivan              | Town and Country        | -             | -         | -       | -                  |
|          |              |                      | Voyager                 | Caravan       | -         | -       | -                  |
| CS       | 2003–2008    | crossover SUV        | Pacifica                | -             | -         | -       | -                  |
| JS       | 2007–present | sedan/convertible    | Sebring Convertible     | -             | -         | -       | -                  |
|          |              |                      | Sebring Sedan           | -             | Avenger   | -       | -                  |
| PM/MK    | 2007–present | compact car          | -                       | Caliber       | -         | -       | Patriot<br>Compass |
| RT       | 2008–present | minivan              | Town and Country        | -             | -         | -       | -                  |
|          |              |                      | Voyager                 | Caravan       | -         | -       | -                  |



## Platform and Tophats of Chrysler (continued)

| Platform       | Years        | Vehicle Type  | Tophats          |            |             |       |      |
|----------------|--------------|---------------|------------------|------------|-------------|-------|------|
|                |              |               | Chrysler         | Dodge      | Plymouth    | Eagle | Jeep |
| A              | 1960–1977    | compact car   | -                | Dart       | Barracuda   |       |      |
|                |              |               |                  | Demon      | Duster      |       |      |
|                |              |               |                  | Lancer     | Scamp       |       |      |
| B              | 1962–1979    | mid-size car  |                  |            | Valiant     |       |      |
|                |              |               | 300              | Charger    | Belvedere   |       |      |
|                |              |               | Cordoba          | Coronet    | Fury        |       |      |
|                |              |               |                  | Dart       | GTX         |       |      |
|                |              |               |                  | Magnum     | Road Runner |       |      |
|                |              |               |                  | Monaco     | Satellite   |       |      |
| C              | 1965–1977    | full-size car |                  | Polara     | Savoy       |       |      |
|                |              |               | 300              | Monaco     | Fury        |       |      |
|                |              |               | Imperial         | Polara     | Gran Fury   |       |      |
|                |              |               | New Yorker       |            | VIP         |       |      |
| D              | 1957–1973    | full-size car | Newport          |            |             |       |      |
|                |              |               | Town and Country |            |             |       |      |
| E              | 1970–1974    | coupe         | Imperial         | -          | -           |       |      |
| F              | 1976–1980    | compact car   | -                | Challenger | Barracuda   |       |      |
|                |              |               |                  |            | Duster      |       |      |
|                |              |               |                  | Aspen      | Road Runner |       |      |
| M              | 1977–1989    | mid-size car  |                  |            | Volare      |       |      |
|                |              |               | LeBaron          |            |             |       |      |
|                |              |               | Fifth Avenue     |            |             |       |      |
|                |              |               | New Yorker       |            |             |       |      |
|                |              |               | Town and Country | Diplomat   | Gran Fury   |       |      |
| R              | 1979–1981    | full-size car | Newport          |            |             |       |      |
| J              | 1980–1983    | coupe         | New Yorker       | St. Regis  | Gran Fury   |       |      |
|                |              |               | Cordoba          |            |             |       |      |
| SR             | 1992–2002    | sports car    | Imperial         | Mirada     | -           |       |      |
| PR             | 1997–2002    | sports car    | -                | Viper      | -           |       |      |
| LX             | 2005–present | full-size car | Prowler          | -          | Prowler     |       |      |
|                |              |               |                  | Magnum     |             |       |      |
| ZH             | 2005–2008    | sports car    | 300              | Charger    | -           |       |      |
| LC             | 2008–present | sports car    | Crossfire        | -          | -           |       |      |
| ZB             | 2003–present | sports car    | -                | Challenger | -           |       |      |
| AB             | 1971–2003    | Truck         | -                | Sportsman  |             |       |      |
|                |              |               |                  | Tradesman  |             |       |      |
|                |              |               |                  | Ram Van    |             |       |      |
|                |              |               |                  | Ram Wagon  | Voyager     |       |      |
| AD             | 1972–1993    | Truck         | -                | D-Series   |             |       |      |
| AN             | 1987–2004    | Truck         |                  | Ramcharger | Trailduster |       |      |
| BE/BR          | 1994–2001    | Truck         | -                | Ram        | -           |       |      |
| DN             | 1998–2003    | Truck         | -                | Durango    | -           |       |      |
| DR/DH/DC/DM/D1 | 2002–2008    | Truck         | -                | Ram        | -           |       |      |
| ND             | 2005–present | Truck         | -                | Dakota     | -           |       |      |
| HB/HG          | 2002–present | Truck         | Aspen            | Durango    | -           |       |      |
| DS             | 2009–present | Truck         |                  | Ram        | -           |       |      |

## Platform and Tophats of Volkswagen

| platform code                 | Type                          | Tophats  |
|-------------------------------|-------------------------------|--|
| PQ24 <sup>[2]</sup>           | <u>supermini cars</u>         | Volkswagen Polo (9N), SEAT Ibiza (6L), Škoda Fabia (6Y)                                  |
| PQ25 <sup>[2]</sup>           | supermini cars                | Volkswagen Polo (6R), SEAT Ibiza (6J)  |
| PQ34 <sup>[2]</sup>           | <u>small family cars</u>      | Audi A3 (8L),  |
|                               | <u>/ compact cars</u>         | Volkswagen Golf (1J),  |
| PQ35 <sup>[2]</sup>           | small family cars             | Audi A3 (8P),  |
|                               | <u>/ compact cars</u>         | Volkswagen Golf (1K),  |
| PL45 <sup>[2]</sup>           | <u>mid-size cars</u>          | Audi A4 (8D), Volkswagen Passat (3B)   |
| PL45+ <sup>[2]</sup>          | mid-size cars                 | Volkswagen Passat Lingyu, Škoda Superb (3U)  |
| PQ46 <sup>[2]</sup>           | mid-size cars                 | Volkswagen Passat (3C), Škoda Superb (3T)  |
| PL46 <sup>[2]</sup>           | mid-size cars                 | Audi A4 (8E B6)  |
| PL47 <sup>[2]</sup>           | mid-size cars                 | Audi A4 (8E B7), SEAT Exeo   |
| MLB/MLP (PL48) <sup>[2]</sup> | mid-size cars and larger      | Audi A4 (B8), Audi A5, Audi Q5   |
| PL62 <sup>[2]</sup>           | full-size luxury cars         | Audi A8, Bentley Continental Flying Spur, Bentley Continental GT/GTC, Volkswagen Phaeton |
| PL64 <sup>[2]</sup>           | full-size luxury cars         | Audi A8, Bentley Continental GT, Volkswagen Phaeton                                      |
| PL71 <sup>[2]</sup>           | sport utility vehicles (SUVs) | Audi Q7, Porsche Cayenne, Volkswagen Touareg   |

## Appendix B: Studio Designed Tophat commodities

| COMPONENT                                      | DESIGN STUDIO DELIVERABLE      | BODY ENG. DELIVERABLE  | FINAL SURF. RELEASE | OWNER SUB-SYSTEM | FUNCTIONAL TEAM |
|--|--------------------------------|------------------------|---------------------|------------------|-----------------|
| Air Bag Cover                                  | EMM Surface                    | N/A                    | EMM                 | IP               | Interior        |
| Appliqués                                      | EMM Surface                    | N/A                    | EMM                 | IP               | Interior        |
| Badges   | EMM Surface                    | N/A                    | EMM                 | IP               | Interior        |
| Binnacle                                       | EMM Surface                    | N/A                    | EMM                 | IP               | Interior        |
| Center Finish Panel                            | EMM Surface                    | N/A                    | EMM                 | IP               | Interior        |
| Climate Control Buttons                        | 2 Scan or Surf / FC4           | Surface / FC5 & ST     | Supplier            | Electrical       | Electrical      |
| Clock Bezel                                    | EMM Surface                    | N/A                    | EMM                 | IP               | Interior        |
| Clock Face                                     | 2 Scan or Surf / FC4           | Surface / FC5 & ST     | Supplier            | Electrical       | Electrical      |
| Clock Lens                                     | EMM Surface                    | N/A                    | EMM                 | Electrical       | Electrical      |
| Cluster Mask                                   | 2 Scan or Surf / FC4           | Surface / FC5 & ST     | Supplier            | IP               | Interior        |
| Cluster Graphics                               | 2 2-D Digital / FC4            | 2-D digital / FC5 & ST | Supplier            | Electrical       | Electrical      |
| Cluster Lens                                   | EMM Surface                    | N/A                    | EMM                 | Electrical       | Electrical      |
| Cluster Pointers                               | 2 Scan or Surf / FC4           | Surface / FC5 & ST     | Supplier            | Electrical       | Electrical      |
| D70 Panel                                      | EMM Surface                    | N/A                    | EMM                 | IP               | Interior        |
| D70 Trim Ring                                  | EMM Surface                    | N/A                    | EMM                 | IP               | Interior        |
| Defroster Panel                                | EMM Surface                    | N/A                    | EMM                 | IP               | Interior        |
| Demister Bezel                                 | EMM Surface                    | N/A                    | EMM                 | IP               | Interior        |
| Demister Grille/Mesh                           | 2 Curves on Surface FC4/FC5/ST | Surface / Post ST      | Supplier            | IP               | Interior        |
| Demister Switch Bezel                          | EMM Surface                    | N/A                    | EMM                 | IP               | Interior        |
| Dimmer Switch                                  | EMM Surface                    | N/A                    | Supplier            | Electrical       | Electrical      |
| Endcap   | EMM Surface                    | N/A                    | EMM                 | IP               | Interior        |
| Finish Panels                                  | EMM Surface                    | N/A                    | EMM                 | IP               | Interior        |
| Glove Box Door                                 | EMM Surface                    | N/A                    | EMM                 | IP               | Interior        |
| Glove Box Handle                               | 1 See Note                     | Surface / FC5 & ST     | Supplier            | IP               | Interior        |
| Glove Box Inner Door                           | 1 See Note                     | Surface / FC5 & ST     | Supplier            | IP               | Interior        |
| Glove Box Latch                                | 1 See Note                     | Surface / FC5 & ST     | Supplier            | IP               | Interior        |
| Hazard Button                                  | 2 Scan or Surf / FC4           | Surface / FC5 & ST     | Supplier            | Electrical       | Electrical      |
| Head Lamp Switch                               | 2 Scan or Surf / FC4           | Surface / FC5 & ST     | Supplier            | Electrical       | Electrical      |
| Head Lamp Switch Bezel                         | EMM Surface                    | N/A                    | EMM                 | IP               | Interior        |
| Hood Release Handle                            | 2 Scan or Surf / FC4           | Surface / FC5 & ST     | Supplier            | Sheet Metal      | Exterior        |
| HUD Lens                                       | EMM Surface                    | Surface / FC5 & ST     | Supplier            | Electrical       | Electrical      |
| Hush Panel (under Glove Box)                   | 2 Scan or Surf / FC4           | Surface / FC5 & ST     | Supplier            | IP               | Interior        |
| Ignition Switch Bezel                          | EMM Surface                    | Surface / FC5 & ST     | Supplier            | IP               | Interior        |
| IP Bin   | EMM Surface                    | N/A                    | EMM                 | IP               | Interior        |
| IP Bin Button                                  | 1 See Note                     | Surface / FC5 & ST     | Supplier            | IP               | Interior        |
| IP Bin Cover                                   | 1 See Note                     | N/A                    | EMM                 | IP               | Interior        |
| IP Bin Mat                                     | EMM Surface                    | N/A                    | EMM                 | IP               | Interior        |
| IP Coin Holder (Exposed)                       | EMM Surface                    | N/A                    | EMM                 | IP               | Interior        |
| IP Substrate                                   | EMM Surface                    | N/A                    | EMM                 | IP               | Interior        |
| IP Upper Bin (Truck)                           | EMM Surface                    | N/A                    | EMM                 | IP               | Interior        |
| Key FOB  | 2 Scan or Surf / FC4           | Surface / FC5 & ST     | Supplier            | Electrical       | Electrical      |
| Lens Hub                                       | EMM Surface                    | N/A                    | EMM                 | Electrical       | Electrical      |
| Message Center                                 | 2 Scan or Surf / FC4           | Surface / FC5 & ST     | Supplier            | Electrical       | Electrical      |
| Message Center Buttons                         | 2 Scan or Surf / FC4           | Surface / FC5 & ST     | Supplier            | Electrical       | Electrical      |
| Message Center Knobs                           | 2 Scan or Surf / FC4           | Surface / FC5 & ST     | Supplier            | Electrical       | Electrical      |
| Multi-Function Stalk                           | 2 Scan or Surf / FC4           | Surface / FC5 & ST     | Supplier            | Steering wheel   | Interior        |
| Navigation & Non-Nav EFP's (6 diff. offerings) | 2 Scan or Surf / FC4           | Surface / FC5 & ST     | Supplier            | Electrical       | Electrical      |
| Navigation ACM                                 | 2 Scan or Surf / FC4           | Surface / FC5 & ST     | Supplier            | Electrical       | Electrical      |
| Navigation Buttons                             | 2 Scan or Surf / FC4           | Surface / FC5 & ST     | Supplier            | Electrical       | Electrical      |
| Navigation Display                             | 2 Scan or Surf / FC4           | Surface / FC5 & ST     | Supplier            | Electrical       | Electrical      |
| Non-Nav ACM                                    | 2 Scan or Surf / FC4           | Surface / FC5 & ST     | Supplier            | Electrical       | Electrical      |
| Non-Nav CID                                    | 2 Scan or Surf / FC4           | Surface / FC5 & ST     | Supplier            | Electrical       | Electrical      |
| Non-PADI (FOM)                                 | 2 Scan or Surf / FC4           | Surface / FC5 & ST     | Supplier            | Electrical       | Electrical      |
| PADI   | 2 Scan or Surf / FC4           | Surface / FC5 & ST     | Supplier            | Electrical       | Electrical      |
| Paddle Shifters                                | 2 Scan or Surf / FC4           | Surface / FC5 & ST     | Supplier            | Electrical       | Electrical      |
| Power Point Cap                                | 2 Scan or Surf / FC4           | Surface / FC5 & ST     | Supplier            | IP               | Interior        |
| Power Point Door                               | EMM Surface                    | N/A                    | EMM                 | IP               | Interior        |
| Push to Start Bezel                            | EMM Surface                    | N/A                    | EMM                 | IP               | Interior        |
| Push to Start Button                           | 2 Scan or Surf / FC4           | Surface / FC5 & ST     | Supplier            | Electrical       | Electrical      |
| Radio Buttons                                  | 2 Scan or Surf / FC4           | Surface / FC5 & ST     | Supplier            | Electrical       | Electrical      |
| Radio Knobs                                    | 2 Scan or Surf / FC4           | Surface / FC5 & ST     | Supplier            | Electrical       | Electrical      |
| Register Bezel                                 | EMM Surface                    | N/A                    | EMM                 | IP               | Interior        |
| Register Chicklet/Wheel                        | 2 Scan or Surf / FC4           | Surface / FC5 & ST     | Supplier            | IP               | Interior        |
| Register Housing                               | 2 Scan or Surf / FC4           | Surface / FC5 & ST     | Supplier            | IP               | Interior        |
| Register Vanes                                 | 2 Scan or Surf / FC4           | Surface / FC5 & ST     | Supplier            | IP               | Interior        |
| Sniffer Grille                                 | 2 Curves on Surface / FC4      | Surface / FC5 & ST     | Supplier            | IP               | Interior        |
| Speaker Grille Cover                           | EMM Surface                    | N/A                    | EMM                 | IP               | Interior        |
| Speaker Grille Mesh                            | 2 Curves on Surface / FC4      | Surface / FC5 & ST     | Supplier            | IP               | Interior        |
| Stalk (Turn Single)                            | 2 Scan or Surf / FC4           | Surface / FC5 & ST     | Supplier            | Electrical       | Electrical      |
| Stalk (Wiper Control)                          | 2 Scan or Surf / FC4           | Surface / FC5 & ST     | Supplier            | Electrical       | Electrical      |
| Steering Wheel                                 | EMM Surface                    | N/A                    | EMM                 | Steering wheel   | Interior        |
| Steering Wheel Air Bag Cover                   | EMM Surface                    | N/A                    | EMM                 | Steering wheel   | Interior        |
| Steering Wheel Badge                           | EMM Surface                    | N/A                    | EMM                 | Steering wheel   | Interior        |
| Steering Wheel Switch Bezel                    | EMM Surface                    | N/A                    | EMM                 | Steering wheel   | Interior        |
| Steering Wheel Buttons                         | 2 Scan or Surf / FC4           | Surface / FC5 & ST     | Supplier            | Steering wheel   | Interior        |
| Steering Wheel Ignition Bezel                  | 1 See Note                     | Surface / FC5 & ST     | Supplier            | Steering wheel   | Interior        |

| COMPONENT                     | DESIGN STUDIO DELIVERABLE      | BODY ENG. DELIVERABLE | FINAL SURF. RELEASE | OWNER SUB-SYSTEM | FUNCTIONAL TEAM |
|-------------------------------|--------------------------------|-----------------------|---------------------|------------------|-----------------|
| Steering Wheel Inserts        | EMM Surface                    | N/A                   | EMM                 | Steering wheel   | Interior        |
| Steering Wheel Shroud Lower   | EMM Surface                    | N/A                   | EMM                 | IP               | Interior        |
| Steering Wheel Shroud Upper   | EMM Surface                    | N/A                   | EMM                 | IP               | Interior        |
| Stitching Lines               | 2 C/L Curve on Surface / FC4   | Surface / FCS & ST    | Supplier            | Steering wheel   | Interior        |
| Sunload Sensor                | 1 See Note                     | Surface / FCS & ST    | Supplier            | IP               | Interior        |
| Tilt Levers                   | 2 Scan or Surf / FC4           | Surface / FCS & ST    | Supplier            | Steering wheel   | Interior        |
| Ambient Lighting Bezel        | EMM Surface                    | N/A                   | EMM                 | Console          | Interior        |
| Ambient Lighting Lens         | 1 See Note                     | Surface / FCS & ST    | Supplier            | Console          | Interior        |
| Arm Rest                      | EMM Surface                    | N/A                   | EMM                 | Console          | Interior        |
| Arm Rest Latch                | 1 See Note                     | Surface / FCS & ST    | Supplier            | Console          | Interior        |
| Arm Rest Latch Bezel          | EMM Surface                    | N/A                   | EMM                 | Console          | Interior        |
| Arm Rest Lid Closeout         | 1 See Note                     | Surface / FCS & ST    | Supplier            | Console          | Interior        |
| Arm Rest Lid Latch            | 1 See Note                     | Surface / FCS & ST    | Supplier            | Console          | Interior        |
| Autopark Switch               | 2 Scan or Surf / FC4           | Surface / FCS & ST    | Supplier            | Electrical       | Electrical      |
| Autopark Switch Bezel         | EMM Surface                    | N/A                   | EMM                 | Console          | Interior        |
| Bin Door                      | EMM Surface                    | N/A                   | EMM                 | Console          | Interior        |
| Bin Door Chicklet             | 1 See Note                     | Surface / FCS & ST    | Supplier            | Console          | Interior        |
| Console Badge                 | EMM Surface                    | N/A                   | EMM                 | Console          | Interior        |
| Console Storage Bin (Exposed) | EMM Surface                    | N/A                   | EMM                 | Console          | Interior        |
| Console Trim/Appiqué          | EMM Surface                    | N/A                   | EMM                 | Console          | Interior        |
| Consolette                    | EMM Surface                    | N/A                   | EMM                 | Console          | Interior        |
| Cup Holder (Exposed)          | EMM Surface                    | N/A                   | EMM                 | Console          | Interior        |
| Cup Holder Divider            | EMM Surface                    | N/A                   | EMM                 | Console          | Interior        |
| Cup Holder Insert/Liner       | EMM Surface                    | N/A                   | EMM                 | Console          | Interior        |
| Cup Holder Liner              | EMM Surface                    | N/A                   | EMM                 | Console          | Interior        |
| Cup Holder Mat                | EMM Surface                    | N/A                   | EMM                 | Console          | Interior        |
| Cupholder Door                | EMM Surface                    | N/A                   | EMM                 | Console          | Interior        |
| Heated Seat Bezel             | EMM Surface                    | N/A                   | EMM                 | Console          | Interior        |
| Heated Seat Switch            | 2 Scan or Surf / FC4           | Surface / FCS & ST    | Supplier            | Console          | Interior        |
| Large Storage Tray (Exposed)  | EMM Surface                    | N/A                   | EMM                 | Console          | Interior        |
| Power Point Bezel             | EMM Surface                    | N/A                   | EMM                 | Console          | Interior        |
| Power Point Cap/Door          | 1 See Note                     | Surface / FCS & ST    | Supplier            | Console          | Interior        |
| PRNDL Bezel                   | EMM Surface                    | N/A                   | EMM                 | Powertrain       | Powertrain      |
| Rear Finish Panel             | EMM Surface                    | N/A                   | EMM                 | Console          | Interior        |
| Register Chicklet             | 2 Scan or Surf / FC4           | Surface / FCS & ST    | Supplier            | Console          | Interior        |
| Register Knobs/Wheels         | 2 Scan or Surf / FC4           | Surface / FCS & ST    | Supplier            | Console          | Interior        |
| Register Vanes                | 2 Scan or Surf / FC4           | Surface / FCS & ST    | Supplier            | Console          | Interior        |
| Shifter Boot                  | 2 Image                        | Surface / FCS & ST    | Supplier            | Powertrain       | Powertrain      |
| Shifter Knobs / Handles       | 2 Scan or Surf / FC4           | Surface / FCS & ST    | Supplier            | Powertrain       | Powertrain      |
| Side Finish Panel Lower       | EMM Surface                    | N/A                   | EMM                 | Console          | Interior        |
| Side Finish Panel Upper       | EMM Surface                    | N/A                   | EMM                 | Console          | Interior        |
| Small Storage Tray (Exposed)  | EMM Surface                    | N/A                   | EMM                 | Console          | Interior        |
| Stitching Lines               | 2 C/L Curve on Surface FC4     | Surface / FCS & ST    | Supplier            | Console          | Interior        |
| Storage Bin Tray (Exposed)    | EMM Surface                    | N/A                   | EMM                 | Console          | Interior        |
| Branded Badges (trade mark)   | EMM Surface                    | N/A                   | EMM                 | Console          | Interior        |
| Tambour Door                  | EMM Surface                    | N/A                   | EMM                 | Console          | Interior        |
| Tambour Door Chicklet         | EMM Surface                    | N/A                   | EMM                 | Console          | Interior        |
| Top Finish Panel              | EMM Surface                    | N/A                   | EMM                 | Console          | Interior        |
| USB Port Bezel                | EMM Surface                    | N/A                   | EMM                 | Console          | Interior        |
| Applique                      | EMM Surface                    | N/A                   | EMM                 | Door Trim        | Interior        |
| Arm Rest                      | EMM Surface                    | N/A                   | EMM                 | Door Trim        | Interior        |
| Arm Rest Bezel                | EMM Surface                    | N/A                   | EMM                 | Door Trim        | Interior        |
| Arm Rest Cup Bezel            | EMM Surface                    | N/A                   | EMM                 | Door Trim        | Interior        |
| Arm Rest Handle (360°)        | EMM Surface                    | N/A                   | EMM                 | Door Trim        | Interior        |
| Crank Handle                  | 1 See Note                     | Surface / FCS & ST    | Supplier            | Door Trim        | Interior        |
| Door Inserts                  | EMM Surface                    | N/A                   | EMM                 | Door Trim        | Interior        |
| Heated Seat Switches          | 2 Scan or Surf / FC4           | Surface / FCS & ST    | Supplier            | Electrical       | Electrical      |
| Substrate                     | EMM Surface                    | N/A                   | EMM                 | Door Trim        | Interior        |
| Lock Rod                      | 1 See Note                     | Surface / FCS & ST    | Supplier            | Closures         | Exterior        |
| Lock Rod Bezel                | 1 See Note                     | Surface / FCS & ST    | Supplier            | Door Trim        | Interior        |
| Lock Switches                 | 2 Scan or Surf / FC4           | Surface / FCS & ST    | Supplier            | Electrical       | Electrical      |
| Map Pocket Inner              | 2 Scan or Surf / FC4           | Surface / FCS & ST    | Supplier            | Door Trim        | Interior        |
| Map Pocket Outer              | EMM Surface                    | N/A                   | EMM                 | Door Trim        | Interior        |
| Mirror Switches               | 1 See Note                     | Surface / FCS & ST    | Supplier            | Electrical       | Electrical      |
| Release Handle                | 1 See Note                     | Surface / FCS & ST    | Supplier            | Sheet Metal      | Exterior        |
| Release Handle Bezel          | EMM Surface                    | N/A                   | EMM                 | Door Trim        | Interior        |
| Release Handle Bezel Cup      | EMM Surface                    | N/A                   | EMM                 | Door Trim        | Interior        |
| Sail Panel                    | EMM Surface                    | N/A                   | EMM                 | Door Trim        | Interior        |
| Shoulder Bolster              | EMM Surface                    | N/A                   | EMM                 | Door Trim        | Interior        |
| Speaker Grille Cover          | EMM Surface                    | N/A                   | EMM                 | Door Trim        | Interior        |
| Speaker Grille Mesh           | 2 Curves on Surface / FCS & ST | Surface / FCS & ST    | Supplier            | Door Trim        | Interior        |
| Stitching                     | 2 C/L Curve on Surface FC4     | Surface / FCS & ST    | Supplier            | Door Trim        | Interior        |
| Trim Panel                    | EMM Surface                    | N/A                   | EMM                 | Door Trim        | Interior        |
| Upper Trim                    | EMM Surface                    | N/A                   | EMM                 | Door Trim        | Interior        |
| Window Garnish                | EMM Surface                    | N/A                   | EMM                 | Glass            | Exterior        |
| Window Switches               | 2 Scan or Surf / FC4           | Surface / FCS & ST    | Supplier            | Electrical       | Interior        |
| A Pillar                      | EMM Surface                    | N/A                   | EMM                 | Hard Trim        | Interior        |
| A Pillar Speaker Grille Cover | EMM Surface                    | N/A                   | EMM                 | Hard Trim        | Interior        |



| COMPONENT  | DESIGN STUDIO DELIVERABLE      | BODY ENG. DELIVERABLE | FINAL SURF. RELEASE | OWNER SUB-SYSTEM | FUNCTIONAL TEAM |
|--|--------------------------------|-----------------------|---------------------|------------------|-----------------|
| A Pillar Speaker Grille Mesh                     | 2 Curves on Surface / FC5 & ST | Surface / FC5 & ST    | Supplier            | Hard Trim        | Interior        |
| Assist/Grab Handle Bezel                         | EMM Surface                    | N/A                   | EMM                 | Hard Trim        | Interior        |
| Assist/Grab Handles                              | EMM Surface                    | N/A                   | EMM                 | Hard Trim        | Interior        |
| B Pillar   | EMM Surface                    | N/A                   | EMM                 | Hard Trim        | Interior        |
| B Pillar Lower                                   | EMM Surface                    | N/A                   | EMM                 | Hard Trim        | Interior        |
| B Pillar Upper                                   | EMM Surface                    | N/A                   | EMM                 | Hard Trim        | Interior        |
| C Pillar   | EMM Surface                    | N/A                   | EMM                 | Hard Trim        | Interior        |
| Cargo Storage Bin Outer Panel                    | 1 See Note                     | Surface / FC5 & ST    | Supplier            | Hard Trim        | Interior        |
| Close Out Panel                                  | EMM Surface                    | N/A                   | EMM                 | Hard Trim        | Interior        |
| Coat Hook  | 1 See Note                     | Surface / FC5 & ST    | Supplier            | Hard Trim        | Interior        |
| Cowl Trim  | EMM Surface                    | N/A                   | EMM                 | Hard Trim        | Interior        |
| Cupholder  | EMM Surface                    | N/A                   | EMM                 | Hard Trim        | Interior        |
| D Pillar   | EMM Surface                    | N/A                   | EMM                 | Hard Trim        | Interior        |
| D Pillar Speaker Cover                           | EMM Surface                    | N/A                   | EMM                 | Hard Trim        | Interior        |
| D Pillar Speaker Mesh                            | 2 Curves on Surface / FC5 & ST | Surface / FC5 & ST    | Supplier            | Hard Trim        | Interior        |
| Dome Lamp Bezel                                  | EMM Surface                    | N/A                   | EMM                 | Hard Trim        | Interior        |
| Dome Lamp Lens                                   | EMM Surface                    | N/A                   | EMM                 | Hard Trim        | Interior        |
| Dome Lamp Switch                                 | 2 Scan or Surf / FC4           | Surface / FC5 & ST    | Supplier            | Hard Trim        | Interior        |
| Floor Mat Graphics                               | 2 2-D Digital / FC4            | Surface / FC5 & ST    | Supplier            | Carpet           | Interior        |
| Headliner  | EMM Surface                    | N/A                   | EMM                 | Headliner        | Interior        |
| Headliner W/Fixed Glass                          | EMM Surface                    | N/A                   | EMM                 | Headliner        | Interior        |
| Headliner W/Moonroof                             | EMM Surface                    | N/A                   | EMM                 | Headliner        | Interior        |
| Liftgate Scuff                                   | EMM Surface                    | N/A                   | EMM                 | Hard Trim        | Interior        |
| Liftgate Access Door                             | EMM Surface                    | N/A                   | EMM                 | Hard Trim        | Interior        |
| Liftgate Halo Trim                               | EMM Surface                    | N/A                   | EMM                 | Hard Trim        | Interior        |
| Liftgate Panel                                   | EMM Surface                    | N/A                   | EMM                 | Hard Trim        | Interior        |
| Moonroof Trim/Molding                            | EMM Surface                    | N/A                   | EMM                 | Headliner        | Interior        |
| Overhead Console                                 | EMM Surface                    | N/A                   | EMM                 | Headliner        | Interior        |
| Overhead Console Buttons                         | 2 Scan or Surf / FC4           | Surface / FC5 & ST    | Supplier            | Headliner        | Interior        |
| Overhead Console Door                            | EMM Surface                    | N/A                   | EMM                 | Headliner        | Interior        |
| Overhead Entertainment System                    | 2 Scan or Surf / FC4           | Surface / FC5 & ST    | Supplier            | Headliner        | Interior        |
| Package Tray Child Tether Cap Covers             | EMM Surface                    | N/A                   | EMM                 | Soft Trim        | Interior        |
| Package Tray Rear Seat Belt Bezel                | EMM Surface                    | N/A                   | EMM                 | Soft Trim        | Interior        |
| Package Tray Speaker Grille Cover                | EMM Surface                    | N/A                   | EMM                 | Soft Trim        | Interior        |
| Package Tray Speaker Grille Mesh                 | 2 Curves on Surface / FC5 & ST | Surface / FC5 & ST    | Supplier            | Soft Trim        | Interior        |
| Pedals   | 1 See Note                     | Surface / FC5 & ST    | Supplier            | Brakes           | Chassis         |
| Plug Access Covers                               | EMM Surface                    | N/A                   | EMM                 | Hard Trim        | Interior        |
| Quarter Trim                                     | EMM Surface                    | N/A                   | EMM                 | Hard Trim        | Interior        |
| Quarter Trim Arm Rest                            | EMM Surface                    | N/A                   | EMM                 | Hard Trim        | Interior        |
| Quarter Trim PWR LFT/GT Access Cover             | EMM Surface                    | N/A                   | EMM                 | Hard Trim        | Interior        |
| Quarter Trim Seat Fold Down Bezel                | EMM Surface                    | N/A                   | EMM                 | Hard Trim        | Interior        |
| Rear View Mirror                                 | 2 Scan or Surf / FC4           | Surface / FC5 & ST    | Supplier            | Exterior         | Exterior        |
| Register Bezels                                  | EMM Surface                    | N/A                   | EMM                 | Headliner        | Interior        |
| Scuffplate                                       | EMM Surface                    | N/A                   | EMM                 | Hard Trim        | Interior        |
| Scuffplate Insert                                | EMM Surface                    | N/A                   | EMM                 | Hard Trim        | Interior        |
| Scuffplate Insert Graphics                       | 2 Scan or Surf / FC4           | Surface / FC5 & ST    | Supplier            | Hard Trim        | Interior        |
| Seat Belt Bezel                                  | EMM Surface                    | N/A                   | EMM                 | Hard Trim        | Interior        |
| Seat Belt D Ring Cover                           | EMM Surface                    | N/A                   | EMM                 | Hard Trim        | Interior        |
| Seat Belt D Ring Slider (Adjuster)               | 1 See Note                     | Surface / FC5 & ST    | Supplier            | Hard Trim        | Interior        |
| Side Air Bag Curtain Cover                       | EMM Surface                    | N/A                   | EMM                 | Hard Trim        | Interior        |
| Sun Visor Attachment Cover (Bracket)             | 1 See Note                     | Surface / FC5 & ST    | Supplier            | Headliner        | Interior        |
| Sunvisor   | 1 See Note                     | Surface / FC5 & ST    | Supplier            | Headliner        | Interior        |
| Sunvisor Hook                                    | 1 See Note                     | Surface / FC5 & ST    | Supplier            | Headliner        | Interior        |
| Sunvisor Rod                                     | 1 See Note                     | Surface / FC5 & ST    | Supplier            | Headliner        | Interior        |
| Switch Bezels                                    | EMM Surface                    | N/A                   | EMM                 | Headliner        | Interior        |
| Trunk Trim (Insert Scuff Decklid Trim Cover)     | 2 Scan or Surf / FC4           | Surface / FC5 & ST    | Supplier            | Soft Trim        | Interior        |
| Bench Seat Cushion                               | EMM Surface                    | N/A                   | EMM                 | Seats            | Interior        |
| Headrest   | EMM Surface                    | N/A                   | EMM                 | Seats            | Interior        |
| Lumbar Knob                                      | 1 See Note                     | Surface / FC5 & ST    | Supplier            | Seats            | Interior        |
| Luxury Compartment Bezel                         | EMM Surface                    | N/A                   | EMM                 | Seats            | Interior        |
| Luxury Compartment Door                          | EMM Surface                    | N/A                   | EMM                 | Seats            | Interior        |
| Luxury Compartment Latch                         | 1 See Note                     | Surface / FC5 & ST    | Supplier            | Seats            | Interior        |
| Memory Switch                                    | 2 Scan or Surf / FC4           | Surface / FC5 & ST    | Supplier            | Seats            | Interior        |
| Rail Cover 1 See Note                            | 1 See Note                     | N/A                   | EMM                 | Seats            | Interior        |
| Recliner Handle                                  | 1 See Note                     | Surface / FC5 & ST    | Supplier            | Seats            | Interior        |
| Recliner Handle (integrated in Seat Side Shield) | EMM Surface                    | N/A                   | EMM                 | Seats            | Interior        |
| Seat Armrest                                     | EMM Surface                    | N/A                   | EMM                 | Seats            | Interior        |
| Seat Armrest Pad                                 | EMM Surface                    | N/A                   | EMM                 | Seats            | Interior        |
| Seat Back Cushion                                | EMM Surface                    | N/A                   | EMM                 | Seats            | Interior        |
| Seat Back Panel                                  | EMM Surface                    | N/A                   | EMM                 | Seats            | Interior        |
| Seat Back Shield                                 | EMM Surface                    | N/A                   | EMM                 | Seats            | Interior        |
| Seat Bezel (for Luxury Compartment)              | EMM Surface                    | N/A                   | EMM                 | Seats            | Interior        |
| Seat Cushion                                     | EMM Surface                    | N/A                   | EMM                 | Seats            | Interior        |
| Seat Headrest Footer                             | 1 See Note                     | Surface / FC5 & ST    | Supplier            | Seats            | Interior        |
| Seat Headrest Guide                              | 1 See Note                     | Surface / FC5 & ST    | Supplier            | Seats            | Interior        |
| Seat Height Adjuster (Levers/Knobs)              | 1 See Note                     | Surface / FC5 & ST    | Supplier            | Seats            | Interior        |
| Seat Map Pocket                                  | 1 See Note                     | Surface / FC5 & ST    | Supplier            | Seats            | Interior        |
| Seat Side Shield (inner)                         | EMM Surface                    | N/A                   | EMM                 | Seats            | Interior        |
| Seat Side Shield Access Cover (outer)            | EMM Surface                    | N/A                   | EMM                 | Seats            | Interior        |
| Seat Side Shield Base (outer)                    | EMM Surface                    | N/A                   | EMM                 | Seats            | Interior        |
| Seat Side Shield Upper (outer)                   | EMM Surface                    | N/A                   | EMM                 | Seats            | Interior        |
| Seat Track Covers (All)                          | EMM Surface                    | N/A                   | EMM                 | Seats            | Interior        |
| Stitching Lines                                  | 2 C/L Curve on Surface FC4     | Surface / FC5 & ST    | Supplier            | Seats            | Interior        |

| COMPONENT                          | DESIGN STUDIO DELIVERABLE     | BODY ENG. DELIVERABLE | FINAL SURF. RELEASE | OWNER SUB-SYSTEM  | FUNCTIONAL TEAM |
|------------------------------------|-------------------------------|-----------------------|---------------------|-------------------|-----------------|
| Antenna                            | 2 Scan or Surf / FC4          | Surface / FCS & ST    | Supplier            | Electrical        | Exterior        |
| Antenna Base                       | 2 Scan or Surf / FC4          | Surface / FCS & ST    | Supplier            | Electrical        | Exterior        |
| B Pillar Applique                  | EMM Surface                   | N/A                   | EMM                 | E. Ornammentation | Exterior        |
| Backlite                           | EMM Surface                   | N/A                   | EMM                 | Glass             | Exterior        |
| Badging                            | EMM Surface                   | N/A                   | EMM                 | E. Ornammentation | Exterior        |
| Belt Molding                       | EMM Surface                   | N/A                   | EMM                 | E. Ornammentation | Exterior        |
| Body Side & Quarter                | EMM Surface                   | N/A                   | EMM                 | Sheet Metal       | Exterior        |
| Bumper Cover                       | EMM Surface                   | N/A                   | EMM                 | Facias            | Exterior        |
| Bumpers                            | EMM Surface                   | N/A                   | EMM                 | Facias            | Exterior        |
| C Pillar Applique                  | EMM Surface                   | N/A                   | EMM                 | E. Ornammentation | Exterior        |
| Ceramic Paint Lines (all)          | Curves on Surface / Post B ST | N/A                   | PED                 | Glass             | Exterior        |
| Chimsel Lens                       | EMM Surface                   | N/A                   | EMM                 | Lighting          | Exterior        |
| Chin Spoiler/Lower Valance         | EMM Surface                   | N/A                   | EMM                 | E. Ornammentation | Exterior        |
| Cladding Insert                    | EMM Surface                   | N/A                   | EMM                 | E. Ornammentation | Exterior        |
| Convertible Boot (Hard)            | EMM Surface                   | N/A                   | EMM                 | E. Ornammentation | Exterior        |
| Convertible Boot (Soft)            | 2 Image or Surf / FC4         | Surface / FCS & ST    | Supplier            | E. Ornammentation | Exterior        |
| Decklid                            | EMM Surface                   | N/A                   | EMM                 | Sheet Metal       | Exterior        |
| Decklid Applique                   | EMM Surface                   | N/A                   | EMM                 | E. Ornammentation | Exterior        |
| DLO Molding                        | EMM Surface                   | N/A                   | EMM                 | E. Ornammentation | Exterior        |
| Door Cladding                      | EMM Surface                   | N/A                   | EMM                 | E. Ornammentation | Exterior        |
| Door Handle                        | EMM Surface                   | N/A                   | EMM                 | Closures          | Exterior        |
| Door Glass                         | EMM Surface                   | N/A                   | EMM                 | Glass             | Exterior        |
| Door Molding                       | EMM Surface                   | N/A                   | EMM                 | E. Ornammentation | Exterior        |
| Door Outer                         | EMM Surface                   | N/A                   | EMM                 | Sheet Metal       | Exterior        |
| Graphics                           | 2 2 -D Drawing / Post A ST    | Surface / FCS & ST    | Supplier            | E. Ornammentation | Exterior        |
| Fender Cladding                    | EMM Surface                   | N/A                   | EMM                 | E. Ornammentation | Exterior        |
| Fender Vent                        | EMM Surface                   | N/A                   | EMM                 | Sheet Metal       | Exterior        |
| Fixed Glass (Roof)                 | EMM Surface                   | N/A                   | EMM                 | Glass             | Exterior        |
| Fog Lamp Bezel                     | EMM Surface                   | N/A                   | EMM                 | Lighting          | Exterior        |
| Fog Lamp Delete Cover (Plug)       | EMM Surface                   | N/A                   | EMM                 | Lighting          | Exterior        |
| Fog Lamp Lens                      | EMM Surface                   | N/A                   | EMM                 | Lighting          | Exterior        |
| Forward Crash Sensor               | 2 Scan or Surf / FC4          | Surface / FCS & ST    | Supplier            | Facias            | Exterior        |
| Front Fascia Front Fascia Lower    | EMM Surface                   | N/A                   | EMM                 | Facias            | Exterior        |
| Front Fender                       | EMM Surface                   | N/A                   | EMM                 | Sheet Metal       | Exterior        |
| Fuel Fill Door                     | EMM Surface                   | N/A                   | EMM                 | Sheet Metal       | Exterior        |
| Grille                             | EMM Surface                   | N/A                   | EMM                 | Facias            | Exterior        |
| Grille Insert                      | EMM Surface                   | N/A                   | EMM                 | Facias            | Exterior        |
| Grille Lower                       | EMM Surface                   | N/A                   | EMM                 | Facias            | Exterior        |
| Grille Surround                    | EMM Surface                   | N/A                   | EMM                 | Facias            | Exterior        |
| Grille Upper                       | EMM Surface                   | N/A                   | EMM                 | Facias            | Exterior        |
| Grille Pattern (Curves on Surface) | EMM Line on Surface           | N/A                   | EMM                 | Facias            | Exterior        |
| Headlamp Bezel                     | EMM Surface                   | N/A                   | EMM                 | Lighting          | Exterior        |
| Headlamp Can (Housing) & Parabola  | 2 Image or Surf / FC4         | Surface / FCS & ST    | Supplier            | Lighting          | Exterior        |
| Headlamp Lens                      | EMM Surface                   | N/A                   | EMM                 | Lighting          | Exterior        |
| Headlamp Lens Graphics             | EMM Lines on Surface          | Surface / FCS & ST    | Supplier            | Lighting          | Exterior        |
| Hood                               | EMM Surface                   | N/A                   | EMM                 | Sheet Metal       | Exterior        |
| Key Cylinders                      | 2 Scan or Surf / FC4          | Surface / FCS & ST    | Supplier            | Closures          | Exterior        |
| Keyless Entry Pad                  | 2 Scan or Surf / FC4          | Surface / FCS & ST    | Supplier            | Closures          | Exterior        |
| Leafscreen                         | EMM Surface                   | N/A                   | EMM                 | E. Ornammentation | Exterior        |
| Leafscreen Close-Out (Muckett)     | EMM Surface                   | N/A                   | EMM                 | E. Ornammentation | Exterior        |
| License Plate Brackets             | 1 See Note                    | Surface / FCS & ST    | Supplier            | E. Ornammentation | Exterior        |
| Liftgate                           | EMM Surface                   | N/A                   | EMM                 | Closures          | Exterior        |
| Liftgate Grab Handle (Exposed)     | EMM Surface                   | N/A                   | EMM                 | Closures          | Exterior        |
| Liftgate Grab Handle Bezel         | EMM Surface                   | N/A                   | EMM                 | Closures          | Exterior        |
| Liftgate Lens                      | EMM Surface                   | N/A                   | EMM                 | Closures          | Exterior        |
| Liftgate Lens Bezel                | EMM Surface                   | N/A                   | EMM                 | Closures          | Exterior        |
| Liftgate Applique/Molding          | EMM Surface                   | N/A                   | EMM                 | E. Ornammentation | Exterior        |
| Moon Roof Glass                    | EMM Surface                   | N/A                   | EMM                 | Glass             | Exterior        |
| O/S Mirror                         | EMM Surface                   | N/A                   | EMM                 | E. Ornammentation | Exterior        |
| O/S Mirror Glass                   | 2 Scan or Surf / FC4          | Surface / FCS & ST    | Supplier            | E. Ornammentation | Exterior        |
| O/S Mirror Skullcap                | EMM Surface                   | N/A                   | EMM                 | E. Ornammentation | Exterior        |
| Paint/Pin Strips                   | 2 Scan or Surf / FC4          | Surface / FCS & ST    | Supplier            | Sheet Metal       | Exterior        |
| Parking Sensors                    | 1 See Note                    | Surface / FCS & ST    | Supplier            | Facias            | Exterior        |
| Pick -Up Box Molding               | EMM Surface                   | N/A                   | EMM                 | Exterior          | Exterior        |
| Pick-Up Box Liner                  | 1 See Note                    | Surface / FCS & ST    | Supplier            | E. Ornammentation | Exterior        |
| Pick-Up Box Inner (Sheet Metal)    | Studio Review                 | Studio Approval       | Body CAD            | Exterior          | Exterior        |
| Rear Camera                        | 1 See Note                    | Surface / FCS & ST    | Supplier            | Sheet Metal       | Exterior        |
| Rear Camera Bezel                  | EMM Surface                   | N/A                   | EMM                 | Sheet Metal       | Exterior        |
| Rear Door Divider Bar              | EMM Surface                   | N/A                   | EMM                 | Sheet Metal       | Exterior        |
| Rear Fascia                        | EMM Surface                   | N/A                   | EMM                 | Facias            | Exterior        |
| Rear Fascia Lower/Valance          | EMM Surface                   | N/A                   | EMM                 | Facias            | Exterior        |
| Rear Fascia Step Pad               | EMM Surface                   | N/A                   | EMM                 | Facias            | Exterior        |
| Reflex                             | EMM Surface                   | N/A                   | EMM                 | Lighting          | Exterior        |
| Rocker Molding                     | EMM Surface                   | N/A                   | EMM                 | E. Ornammentation | Exterior        |
| Roof Appliqué                      | EMM Surface                   | N/A                   | EMM                 | E. Ornammentation | Exterior        |
| Roof Ditch Molding                 | EMM Surface                   | N/A                   | EMM                 | E. Ornammentation | Exterior        |
| Roof Rail (Rack)                   | 1 See Note                    | Surface / FCS & ST    | Supplier            | E. Ornammentation | Exterior        |
| Roof Rail Footers                  | 1 See Note                    | Surface / FCS & ST    | Supplier            | E. Ornammentation | Exterior        |
| Roof Running Lights                | 1 See Note                    | Surface / FCS & ST    | Supplier            | E. Ornammentation | Exterior        |
| Running Board Caps                 | EMM Surface                   | N/A                   | EMM                 | E. Ornammentation | Exterior        |
| Running Boards/Step Bar            | EMM Surface                   | N/A                   | EMM                 | E. Ornammentation | Exterior        |
| Satellite Antenna                  | 2 Scan or Surf / FC4          | Surface / FCS & ST    | Supplier            | Sheet Metal       | Exterior        |
| Spoiler                            | EMM Surface                   | N/A                   | EMM                 | E. Ornammentation | Exterior        |
| Splash Shield (Styled Mud Flaps)   | EMM Surface                   | N/A                   | EMM                 | E. Ornammentation | Exterior        |
| Tail Lamp Bezel                    | EMM Surface                   | N/A                   | EMM                 | Lighting          | Exterior        |
| Tail Lamp Can (Housing)            | 2 Surf / FC4                  | Surface / FCS & ST    | Supplier            | Lighting          | Exterior        |
| Tail Lamp Graphics                 | EMM Surface                   | Surface / FCS & ST    | Supplier            | Lighting          | Exterior        |
| Tail Lamp Lens                     | EMM Surface                   | N/A                   | EMM                 | Lighting          | Exterior        |
| Tailgate Applique                  | EMM Surface                   | N/A                   | EMM                 | E. Ornammentation | Exterior        |
| Tailgate Inner (Sheet Metal)       | Studio Review                 | Studio Approval       | Body CAD            | Sheet Metal       | Exterior        |
| Tailgate Liner                     | 1 See Note                    | Surface / FCS & ST    | Supplier            | E. Ornammentation | Exterior        |
| Tailgate Molding                   | EMM Surface                   | N/A                   | EMM                 | E. Ornammentation | Exterior        |
| Tow Hooks                          | 1 See Note                    | Surface / FCS & ST    | Supplier            | E. Ornammentation | Exterior        |
| Trailer Tow Hitch Cover            | EMM Surface                   | N/A                   | EMM                 | E. Ornammentation | Exterior        |
| Underhood Components               | EMM Surface                   | Surface / FCS & ST    | Supplier            | Powertrain        | Exterior        |
| Wheel Cap                          | EMM Surface                   | N/A                   | EMM                 | Wheels            | Exterior        |
| Wheel Covers                       | EMM Surface                   | N/A                   | EMM                 | Wheels            | Exterior        |
| Wheel Lip Molding                  | EMM Surface                   | N/A                   | EMM                 | E. Ornammentation | Exterior        |
| Wheels                             | EMM Surface                   | N/A                   | EMM                 | Wheels            | Exterior        |
| Windshield                         | EMM Surface                   | N/A                   | EMM                 | Glass             | Exterior        |
| Wiper Arm                          | 1 See Note                    | Surface / FCS & ST    | Supplier            | E. Systems        | Exterior        |
| Wiper Blades                       | 1 See Note                    | N/A                   | Supplier            | E. Systems        | Exterior        |
| Wiper Nozzle                       | 1 See Note                    | Surface / FCS & ST    | Supplier            | E. Systems        | Exterior        |

## Appendix C: Work Breakdown Structure (WBS) of Tophat development project

| <b>Id</b> | <b>Task</b>   | <b>Task owner</b>       |
|-----------|---|-------------------------|
| 1         | Vehicle Line Cycle plan definition                                    | Directors               |
| 2         | Brand DNA definition  | Styling                 |
| 3         | Technology Cycle Plan definition                                      | Engineering Management  |
| 4         | Customer and Marketing concepts                                       | Marketing               |
| 5         | Define competitive benchmark set                                      | Marketing               |
| 6         | Manufacturing sites analysis and capacity analysis                    | Decision Makers         |
| 7         | Manufacturing site selection  | Decision Makers         |
| 8         | Supply chain analysis and assessment                                  | Purchasing              |
| 9         | Emotional properties creation   | Styling                 |
| 10        | Program Plattform & Package evaluations                               | Desing Engineering      |
| 11        | Design concept and platform package compatibility                     | Design Engineering      |
| 12        | 2D Porportion sketches development                                    | Styling                 |
| 13        | Proportional model creation   | Studio mill shop        |
| 14        | Wheel & tire strategy defined   | Styling                 |
| 15        | Commodity business plan definition                                    | Core Body Engineering   |
| 16        | Commodity commonality plan  | Pre-Program Engineering |
| 17        | Occupant and mechanical package                                       | Pre-Program Engineering |
| 18        | Market and consumer strategy  | Marketing               |
| 19        | Derivatives definition  | Program Management      |
| 20        | Interbrand agreements   | Program Management      |
| 21        | Design vision model creation  | Styling                 |
| 22        | Define functional content based con Consumer Report Best Buys         | Pre-Program Engineering |
| 23        | 2D Computer Theme Sketches  | Styling                 |
| 24        | 3D models creation  | Styling                 |
| 25        | Scale model creation  | Studio mill shop        |
| 26        | Package and concept clinic  | Marketing               |
| 27        | Theme design reduction to 2 or 3                                      | Decision Makers         |
| 28        | Full scale models of options creation (also Interior Buck) or virtual | Studio mill shop        |
| 29        | Market research plan development and approval                         | Marketing               |
| 30        | Program attribute targets definition based on comp. benchmark         | Vehicle Engineering     |
| 31        | Greenhouse and cockpit architecture theme definition                  | Design Engineering      |
| 32        | Full scale model revision   | Styling                 |
| 33        | Surface clean 3D models development                                   | EMM                     |
| 34        | Theme clinic  | Marketing               |
| 35        | Interior Graphics definition  | Styling                 |
| 36        | Commodity and technology selection completion                         | Program Management      |
| 37        | Update occupant and mechanical package                                | Pre-Program Engineering |
| 38        | 2 Exterior theme alternatives: Important lines defined                | Decision Makers         |
| 39        | Lamps surface and position  | Design Engineering      |
| 40        | Parting lines definition  | Styling                 |
| 41        | Greenhouse components surface definition                              | Styling                 |
| 42        | 2 interior theme alternatives   | Styling                 |
| 43        | Full size model of selected themes                                    | Studio mill shop        |
| 44        | Scan and 3D cleaning of surfaces                                      | EMM                     |
| 45        | Virual approval and release of selected theme surfaces                | Decision Makers         |
| 46        | Initial Color and Material intent                                     | Styling                 |
| 47        | Initial part breakup definition                                       | EMM                     |
| 48        | Materials selection   | Body Engineering        |

| <b>Id</b> | <b>Task</b>  | <b>Task owner</b>        |
|-----------|--|--------------------------|
| 49        | Initial quote package creation                                 | Body Engineering         |
| 50        | Cost estimation of selected themes                             | Cost Estimation          |
| 51        | Potential supplier selection and initial market test           | Purchasing               |
| 52        | Define functional component and system requirements            | Core Body Engineering    |
| 53        | Define craftsmanship targets                                   | Craftsmanship            |
| 54        | Define Homologation requirements                               | Body Engineering         |
| 55        | Define Product Direction Letter                                | Program Management       |
| 56        | Feasibility sections definition                                | Design Engineering       |
| 57        | Perform CAE analyses of vehicle attributes                     | Vehicle Engineering      |
| 58        | Design rules compliance review                                 | Body Engineering         |
| 59        | Functional requirements compliance review                      | Body Engineering         |
| 60        | Program targets compliance review                              | Body Engineering         |
| 61        | Load and service studies                                       | Body Engineering         |
| 62        | Tooling feasibility review                                     | Body Engineering         |
| 63        | System interaction issue resolution                            | Design Engineering       |
| 64        | Engineering disciplines creation                               | Body Engineering         |
| 65        | Generate alternatives for theme compliance                     | Body Engineering         |
| 66        | Propose changes to surfaces                                    | Body Engineering         |
| 67        | Approve alternatives for theme compliance                      | Program Management       |
| 68        | Approve trade-offs for theme compliance                        | Decision Makers          |
| 69        | Surface change in 3D models & feas. clay                       | Styling                  |
| 70        | Supplier selection   | Program Management       |
| 71        | Color and Materials direction                                  | Styling                  |
| 72        | Single theme selection   | Decision Makers          |
| 73        | Update cost assumptions  | Body Engineering         |
| 74        | 3D CAD creation  | Body Engineering         |
| 75        | CAD uploaded into corporate repository                         | All Engineering teams    |
| 76        | Locating and attachment strategy defined                       | Body Engineering         |
| 77        | Varability studies for Craftsmanship                           | Craftsmanship            |
| 78        | Supplier evaluation of CAD                                     | Supplier                 |
| 79        | SC and CC determined   | Body Engineering         |
| 80        | System interaction issue resolution (interference, clearances) | Packaging Engineering    |
| 81        | CAE analysis of components                                     | Body Engineering         |
| 82        | Generate alternatives for theme compliance                     | Body Engineering         |
| 83        | CAD updated from Feasibility process                           | Body Engineering         |
| 84        | Assembly and service evaluation                                | Final assembly & service |
| 85        | Approve alternatives for theme compliance                      | Program Management       |
| 86        | Approve trade-offs for theme compliance                        | Decision Makers          |
| 87        | Update costs of program  | Body Engineering         |
| 88        | Update Program direction letter                                | Program Management       |
| 89        | Feasibility sections updated                                   | Design Engineering       |
| 90        | Propose and negotiate changes to surfaces                      | Body Engineering         |
| 91        | Surface change in 3D models & feas. clay                       | Styling                  |
| 92        | Virtual builds and digital packaging validation                | Packaging Engineering    |
| 93        | Virtual review of final surface                                | Styling                  |
| 94        | Final in and out model build for upper management approval     | Studio mill shop         |
| 95        | Management review and issue identification                     | Decision Makers          |
| 96        | Final surface release  | EMM                      |
| 97        | Final CAD update   | Body Engineering         |
| 98        | CAD released for production tooling                            | Body Engineering         |

## Appendix D: Raw and Partitioned Design Structure Matrices (DSM) of the PDP Design Phase

For task numbers in the DSM, please reference the Id number in the WBS in Appendix C.

- Raw DSM in page 115
- Partitioned DSM is in page 117

THIS PAGE IS INTENTIONALLY LEFT BLANK

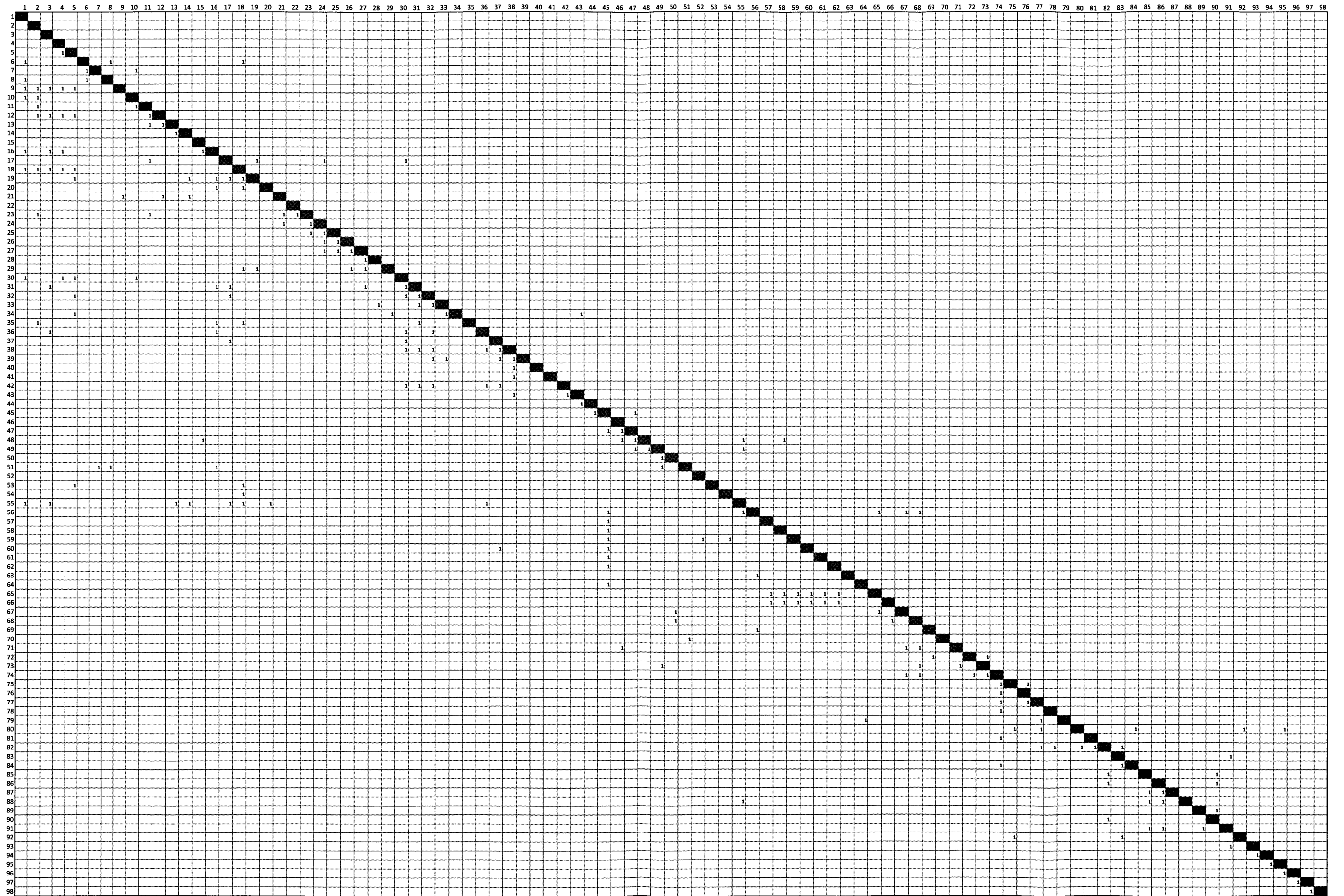

THIS PAGE IS INTENTIONALLY LEFT BLANK



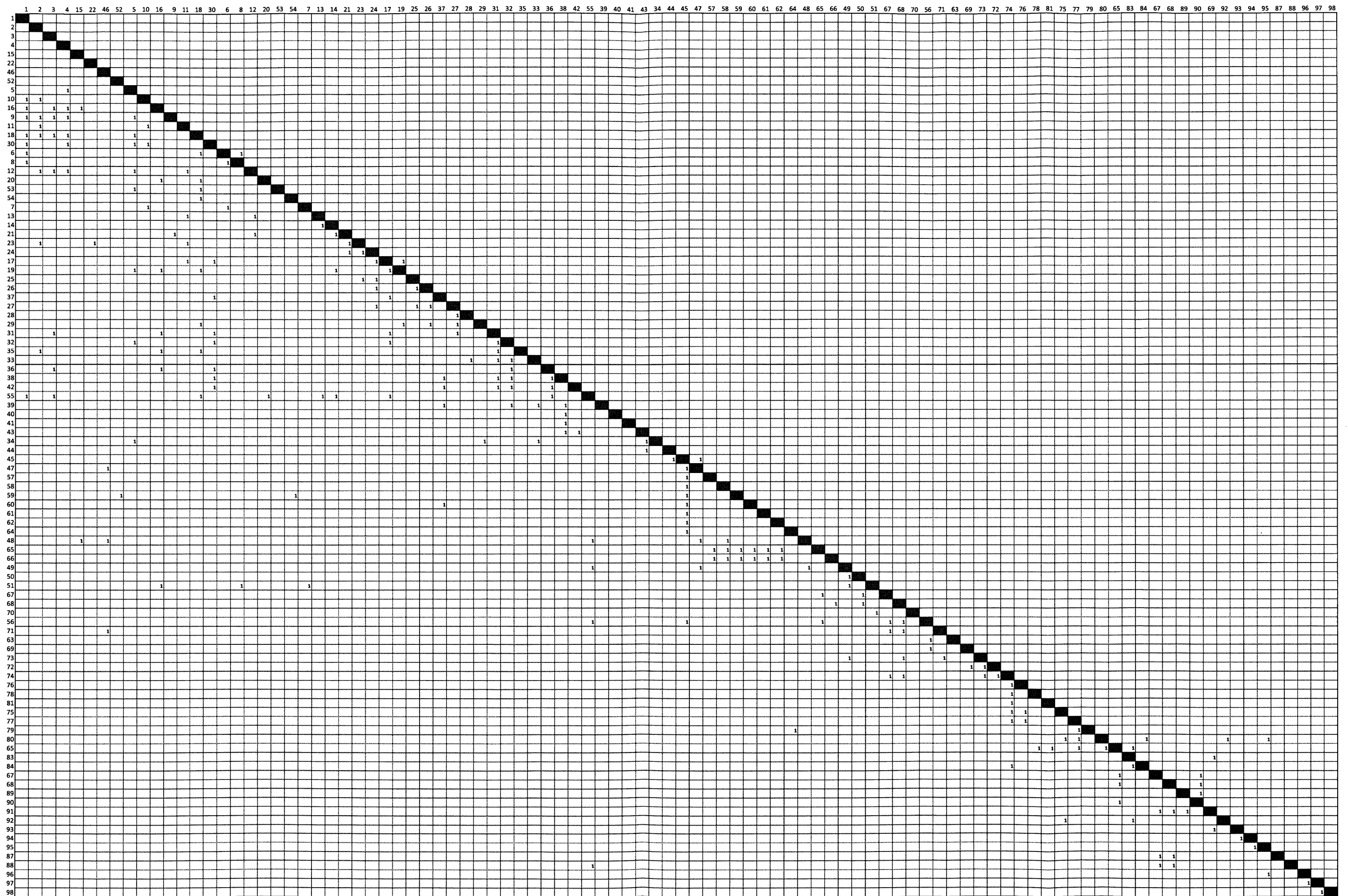

THIS PAGE IS INTENTIONALLY LEFT BLANK

# Bibliography

Aguirre, A. (2006). *Design of Product Development Systems*. Cambridge, MA, USA: MIT.

Allen, T. J. (2008). 15.980 Organizing for the Innovative Product Development. *MIT lecture*. Cambridge, MA, USA: MIT.

Allen, T. J. (1997). *Architecture and Communication among Product Development Engineers*. Cambridge: The International Center for Research on the Management of Technology.

*Automobile platform*. (2010, 1 20). Retrieved 1 20, 2010, from Wikipedia:  
[http://en.wikipedia.org/wiki/Automobile\\_platform](http://en.wikipedia.org/wiki/Automobile_platform)

Bangle, C. (2001, January). The Ultimate Creativity Machine: How BMW Turns Art into Profit. *Harvard Business Review*, pp. 47-55.

Bella, D. (1987). Organisations and systematic distortion of information. *Journal of Professional Issues in Engineering*, 113 (4), 360-70.

Blake, D., Cucuzza, T., & Rishi, S. (2003). Now or never: the automotive collaboration imperative. *Strategy & Leadership*, 9-16.

Body Car Design. (2005, September 9). *Digital Technologies in Car Design - Part 1: Digital drawings and 3D renderings*. Retrieved January 18, 2010, from Body Car Design:  
<http://discussion.autodesk.com/forums/thread.jspa?threadID=702329&start=-2>

Bullis, K. (2007, June 7). *New Batteries Readied for GM's Electric Vehicle*. Retrieved December 29, 2009, from Technology Review (MIT):  
[http://www.technologyreview.com/read\\_article.aspx?ch=specialsections&sc=batteries&id=18833](http://www.technologyreview.com/read_article.aspx?ch=specialsections&sc=batteries&id=18833)

Buxton, W., & al., e. (2000, July / August). Large Displays in Automotive Design. *IEEE Xplore*, pp. 68-75.

*Clay Modelling*. (n.d.). Retrieved 12 29, 2009, from Car Design Online:  
<http://www.carsdesignonline.com/design/modelling/clay-modelling.php>

Daimler-Chrysler. (n.d.). 2005 *Mercedes-Benz CLK Cabriolet by Giorgio Armani - Interior*. Retrieved December 29, 2009, from Serious Wheels: <http://www.seriouswheels.com/2005/2005-Mercedes-Benz-CLK-Cabriolet-Armani-Interior-1280x960.htm>

De Weck, O. (2008). MIT Lectures ESD.36.

De Weck, O., & Haberfellner, R.

Dong, Q. (2002). *Predicting and managing system Interaction at early phase of the product development process*. Cambridge: MIT.

Hansen, M. T., Mors, M. L., & Lovas, B. (2005). Knowledge Sharing in Organizations: Multiple Networks, Multiple Phases. *Academy of Management Journal* , 776-793.

Huckman, R. (2006). McDonalds case. *Harvard Business School case* . Cambridge, MA: HBS.

Katz, R. (2008, January). ESD.37 The Human Side of Technology. *MIT Lecture* . Cambridge, MA.

Khan, A., Matejka, J., Fitzmaurice, G., Kuertenbach, G., Burtnyk, N., & Buxton, B. (2009). Toward the Digital Design Studio: Large Display Explorations. *Human-Computer interaction* , 9-47.

Larkin, J. (2006, December). *Ford's new Way Forward*. Retrieved December 29, 2009, from Automotive Industries: [http://www.ai-online.com/Adv/Previous/show\\_issue.php?id=1615](http://www.ai-online.com/Adv/Previous/show_issue.php?id=1615)

Lewin, T. (2003). *How to: Design Cars Like a Pro*. St. Paul: Motorbooks International.

Liker, J. K., Ettl, J. E., & Campbell, J. C. *Engineered in Japan: Japanese technology-management practices*. Oxford University Press.

MacCormack, A., Rusnak, J., & Baldwin, C. Y. (2006, July). Exploring the Structure of Complex Software Designs: An Empirical Study of Open Source and Proprietary Code. *Management Science* , pp. 1015-1030.

McDaniel, C. D. (1996, June). A Linear Systems Framework for Analyzing the Automotive Appearance Design Process. Cambridge, Massachusetts, USA: MIT.

Mengoni, M., & al., e. (2007). Reverse engineering of aesthetics products: use of hand-made sketches for the design intent formalization. *Journal of Engineering Design* , 413-435.

Mercedes-Benz. (2008, January 29). *Mercedes-Benz Advanced Design Studio - Como, Italy*. Retrieved December 29, 2009, from Car Body Design: <http://www.carbodydesign.com/archive/2008/01/29-mercedes-benz-advanced-design-studio-como/>

Morelli, M. D., Eppinger, S. D., & Gulati, K. R. (1995). Predicting Technical Communications in Product Development Organizations. *IEEE Transactions of Engineering Management* , 215-223.

Morgan, J. M., & Liker, J. K. (2006). *The Toyota Product Development System*. New York: Productivity Press.

Morrison, B. (2009). 15.874 Lecture notes. Cambridge: MIT.

Senge, P. (1990). *The Fifth Discipline: The Art and Practice of the Learning Organization*. Doubleday Currency.

(2009, September 1). Senior Design Engineer. (A. Del Puerto, Interviewer)

Shigley, J., & Mischke, C. (1989). *Mechanical Enigneering Design*. New York: McGraw-Hill.

Smaling, R., & de Weck, O. (2007). Assessing Risks and Opportunities of Technology Infusion in System Design. *Systems Engineering* , 1-25.

Smallman, C., & Weir, D. (1999). Communication and cultural distortion during crises. *Disaster Prevention and Management* , 33.

Sobek II, D. K., Ward, A. C., & Liker, J. K. (1999). Toyota's principles of set-based concurrent engineering. *Sloan Management Review* , 67-83.

Thomke, S. (2001, November 1). BMW AG: The Digital Car Project. *Harvard Business School* , 21 pp. Cambridge, MA, USA: Harvard Business School.

Thomke, S. (2001). Managing digital design at BMW. *Design Management Journal* , 20-28.

Vanderwerp, D. (2008, July). *2009 BMW 750i / 750Li - First Drive Review*. Retrieved December 29, 2009, from [http://www.caranddriver.com/reviews/car/08q3/2009\\_bmw\\_750i\\_750li-first\\_drive\\_review](http://www.caranddriver.com/reviews/car/08q3/2009_bmw_750i_750li-first_drive_review)

Ward, A. L. (1995). The Second Toyota Paradox: How Delaying Decisions Can Make Better Cars Faster. *SLOAN MANAGEMENT REVIEW* , 43-61.