

The Design of Active Workspaces

by

Wendy Guang-wen Ju

B.S. Mechanical Engineering

Stanford University

1997

Submitted to the

Program in Media Arts and Sciences

School of Architecture and Planning

in partial fulfillment of the requirements

for the degree of Master of Science in Media Arts and Sciences

at the Massachusetts Institute of Technology

September 2001

© Massachusetts Institute of Technology 2001.

All Rights Reserved

Author

WJ

Program in Media Arts & Sciences
August 31, 2001

Certified by

[Signature]

Dr. Michael J. Hawley
Media Laboratory

Accepted by

14

Dr. Andrew Lippman
Departmental Chair
Committee on Graduate Studies
Program in Media Arts & Sciences

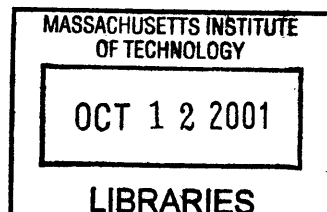

ROTCH

The Design of Active Workspaces

By

Wendy Guang-wen Ju

Submitted to the

Program in Media Arts and Sciences

School of Architecture and Planning

in partial fulfillment of the requirements

for the degree of Master of Science in Media Arts and Sciences

A B S T R A C T

This thesis investigates the creation of context-specific environments designed to assist people engaged in productive tasks. These Active Workspaces are an emerging class of applications that combine interaction design, innovative input and output techniques and multi-media coaching methodologies to teach people to create things in the physical domain.

The design and implementation of two systems that exemplify the features, process and goals of Active Workspace design are detailed and evaluated. CounterActive is an interactive kitchen counter that guides users of varying age and skill level through the preparation of several recipes. CounterActive enlivens the experience of cooking with instructional videos, illustrative photos, entertaining music and sounds. Origami Desk is an exhibit that teaches people how to fold paper into beautiful boxes and cranes. The desk not only projects animations and videos for the user to mimic, but also monitors the folding of the paper to enable performance feedback.

These project descriptions are accompanied by generalized principles for the design of Active Workspaces, process guidelines, and as well as analysis of relevant technologies and ruminations on possible future applications in this arena.

Thesis Supervisor: Dr. Michael J. Hawley
Media Laboratory

The Design of Active Workspaces

Thesis Committee

Thesis Advisor

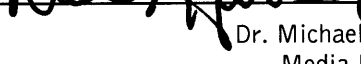

Dr. Michael J. Hawley
Media Laboratory

Thesis Reader

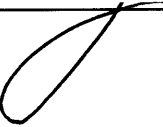

Dr. Joseph A. Paradiso
Principal Research Scientist
Media Laboratory

Thesis Reader



Chee Pearlman
Design Consultant
Columnist for New York Times

A C K N O W L E D G E M E N T S

None of the wild and crazy ideas described in the following pages could have been made real without my fellow co-conspirators. I would like to take this opportunity to thank my undergraduate research assistants, Tilke Judd, Bonny Lee, Camilo Guacqueta, Rebecca Hurwitz and Jennifer Yoon for their enthusiasm, creativity, and countless hours of hard work in all of these projects. I would also like to credit my fellow graduate collaborators, Leonardo Bonanni, Matthew Reynolds, Rehmi Post, Richard Fletcher and Joseph Kaye, who generously shared their expertise, talent and desire to invent fantastic new things with me.

I would also like to extend my appreciation to my readers, Chee Pearlman and Joseph Paradiso, whose guidance has seen me through this thesis. Thanks, too, to my mentors Bill Verplank, whose thoughtful sketches and always-insightful observations have been co-opted wholesale into my design philosophy, and Joseph Meiring, whose generous advice on exhibit design and production was simply indispensable to this budding designer.

I am deeply indebted to my parents for their constant encouragement, my sister for her 5 a.m. paper edits and Justin, for his unflagging emotional support. Also, the members of Personal Information Architecture have become like a second family to me, providing assistance, advice and a friendly ear always.

Finally, the many logistical challenges of each of these projects were met by the steadfast assistance of Christopher Newell, whose feats of organizational savvy (and good taste) never fail to amaze. And most of all, I applaud the clear-eyed direction of my advisor Michael Hawley. Thank you for always pushing me reach a little farther and inspiring me dream bigger.

TABLE OF CONTENTS

Abstract.....	3
Acknowledgements	7
Table of Contents	9
Chapter 1. Introduction	11
What are Active Workspaces?	12
Why Active Workspace design?	13
Active.....	13
Workspaces	14
Design	15
Motivation for this Thesis	16
Chapter 2. Background.....	17
The Origins of Active Workspaces.....	18
Computing Paradigms.....	20
How Active Workspaces are not like Brains.....	21
How Active Workspaces are like and not like Media	22
How Active Workspaces are tools (but not like other tools)	24
Key Features of Active Workspace Design.....	25
Chapter 3. CounterActive.....	27
Previous Work.....	30
Commercial kitchens of the future.....	31
Academic and Research Kitchens	32
Counter Intelligence at the MIT Media Lab.....	34
System Description	34
The Design of CounterActive	36
The Kids in the Kitchen scenario	36
Interaction design	38
Interactive recipe design.....	38
The tauFish array.....	41
Tags and tools.....	42
Evaluation.....	42
Conceptual evaluation	43
Heuristic inspections	44
User tests	45
Future Implications	45
Chapter 4. Origami Desk.....	47
Previous Work.....	49
Origami and other animated origami software.....	49
The Origami Electronic Performance Support System.....	50
HyperGami	51

System Description	52
The Design of Origami Desk	53
Interaction design	53
Fold sensor design.....	54
Paper design.....	57
Pattern recognition	59
Interface design	60
Structure design.....	61
System integration	63
Evaluation.....	65
User testing	67
Future Implications	68
Chapter 5. Conclusion.....	69
Design Principles for Active Workspaces	69
Process guidelines.....	70
New directions.....	71
Appendix A. CounterActive Screenshots	73
Appendix B. User Test Procedure.....	75
Appendix C. User Test Results	78
Appendix D. Origami Desk Screenshots	81
Appendix E. Origami Paper State Data	85
Bibliography	89

CHAPTER 1. INTRODUCTION

"The workbench is to the dedicated woodworker what an instrument is to the virtuoso musician. In the hands of a master, the bench can be made to produce works of brilliance; it can be 'played' with an almost audible clarity. Like a musical instrument, however, the bench is no better than the person using it. At the same time, even the most skilled craftsman with the finest tools will be limited by a poorly made or ill-conceived workbench."

— Scott Landis, *The Workbench Book*

Workspaces have always been magical. After all, they are the sites of so many miraculous transformations—where people turn eggs, flour and sugar into cake, or wood, nails and glue into birdhouses.

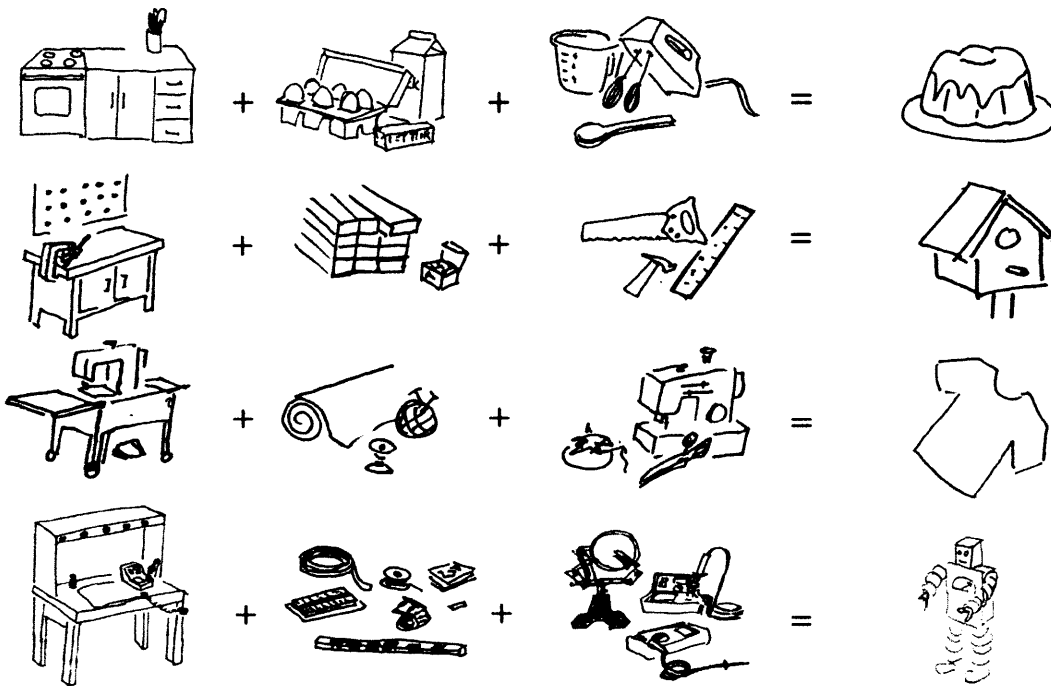

Of course, the real magic is not in the workspaces themselves, but in the agile mix of the well-appointed environment, the necessary materials, the proper tools, and of course, capable people. The right ensemble can be wonderfully felicitous for creative

work, but each element has certain affordances and constraints that affect the interplay.

This thesis argues for the creation of the next generation of such workspaces, which are made possible by the advent of dynamic new technologies. The case for the design of Active Workspaces is substantiated by two projects, entitled CounterActive and Origami Desk. CounterActive is an interactive kitchen counter that guides users of varying age and skill level through the preparation of several recipes. CounterActive enlivens the experience of cooking with instructional videos, illustrative photos, entertaining music and sounds. Origami Desk is an exhibit that teaches people how to fold paper into beautiful boxes and cranes. The desk not only projects animations and videos for the user to mimic, but also monitors the folding of the paper to enable performance feedback.

These two ventures into Active Workspace design illustrate how workspaces are transformed when new technologies are thrown into the brew. Your origami paper changes color depending on what you are folding. Your once silent kitchen counter belts out jaunty French tunes as you make tapenade. These fairy-tale scenarios and more have been made real by a potent mix of computing and sensing technologies designed to support physical interactions in the real world.

This document sketches a history of computers in the workspace, compares Active Workspace design to existing work, and describes the invention and implementation of CounterActive and Origami Desk. This research into this new class of context-specific environments leads us to extract general design principles, process guidelines and notes on enabling technologies to help guide future projects in this arena.

What are Active Workspaces?

Active Workspaces are places where people work with tangible tools and corporeal materials to produce end products. These spaces, tools and materials may be augmented with displays and speakers to inform and guide people's work, networked sensors and actuators to help detect people's actions and changes in the environment,

and computers to coordinate all these elements into a cohesive whole. But while the features of different active work environments are as diverse as the products they make, commonalities in the technology and the design process unify this broad class of applications.

The individual capabilities to bring these workspaces to life are well within reach of our current technologies. Active Workspaces, however, are still “of the future” because the art of marrying the technologies to real needs and solutions is a tough job. The challenges lie not in sticking a sensor here or a processor there but in identifying conditions that lead to good work and creating environments that propagate them. Thus, the design of these Active Workspaces requires feats of engineering, yes, but also sound understandings of human needs and work processes, and a willingness to think of current technologies in new ways meet those needs. The real wizardry lies in integrating technologies, relevant information, applicable entertainment and people’s practices into a coherent design that adapts to people and responds to changes in the environment.

Why Active Workspace design?



Active

Active Workspaces use technology to help people, not replace them. Thus, the technologies used focus on the universal needs in human work, play and performance:

Object tracking: No matter how organized the worker, looking for *things*—tools, materials, half-finished projects—is always a large part of the job. Imagine how great it would be if you did not have to divine where the scissors were left last, or guess if you have enough yarn to finish that scarf. The management of physical artifacts in the workspace would save anyone many an hour of frustration.

Knowledge management: Creation often depends not only on having the right tool or the right material but on having the right piece of information at the right time, whether it is the instructions, background information on the parts or tangential entertainment. Wouldn't it be wonderful if, by touching your soldering probe to an integrated chip, your soldering station would be alerted to pull up the manufacturer's data specifications or prior designs you had created using the part?

Learning: How do you improve? The computer can do more than just hold just facts or data; it can monitor your work, correct errors, choreograph movements, or provide feedback to help develop technique. And although computer technology may facilitate cooperative work, it is also useful for people work alone.

Workspaces

There are numerous reasons why it is important to support work in the physical domain, but here are the most pertinent:

Continued need: Although machines are preferable for tasks that are very precise and highly repetitive, people are still the best at tasks where there are large degrees of variability, which require judgment and adaptability. Even with rapid prototyping technologies available, it is common to make objects of great complexity by hand for testing and development, long before the possibility of mass manufacture exists.

Personal touch: There are also tasks that we may never want to wholly hand over to machines. These are frequently situations of tradition and ritual, wherein the vagaries of human work have sentimental value, or of personal expression, such as cooking dinner for the family or writing a sympathy card.

Hands-on learning: Creativity and craftsmanship often arise out of the intimate relationship creators have with their materials and tools. The act of making something not only develops muscles in the body but also sharpens the attention to detail and refines ideas in the mind.

Design

In this thesis, design is a practice, a process and above all, a philosophy. We address the issue of Active Workspaces from a design perspective for three reasons:

Human-centric focus: Because Active Workspaces revolve around people's need for improved work environments, the designer is responsible for developing applications that match human use scenarios to the capabilities of the technologies available. It is important at every turn that the strengths of the technologies never trump what is best for the user.

Multi-disciplinary integration: At the same time, Active Workspaces are only made possible by the judicious integration of various media, communication, and sensing technologies. The designer's talents lie not necessarily in developing innovations in any particular technology but rather seeing how technologies may be woven together to form a larger whole—and in seeing what ways the technology should change for practical application.

Implementation: The introduction of designers into the creation of technology objects forces the question of what is really feasible, not just physically possible. Design is realm for practitioners, not theorists. That said, it is the practice of planning and reflection that distinguishes design from mere building.

Motivation for this Thesis

This thesis is written with the agenda of promoting everyday activities—anything where people are working or making things. Traditional workspaces are highly context-specific, and yet there are constants that define a “good workspace,” like adequate lighting, storage for tools and materials, and space to work; this thesis seeks to identify such constants for spaces to come. For instance, Active Workspaces can address the need for more information, for choreography of physical actions and the desire for real-time feedback on their actions and performance. By drawing analogs across workspaces of great diversity, we may find shared solutions to pitfalls that bedevil the chef in the kitchen, the weightlifter in the gym, and the engineer at the soldering bench.

To this end, we examine the design of two Active Workspace environments, and generalize lessons from each to apply to Active Workspaces of other varieties. The unifying characteristics of these workspaces lie not only in their technologies, processes and designs but also in the shared premise of human-powered creation at the heart of each design.

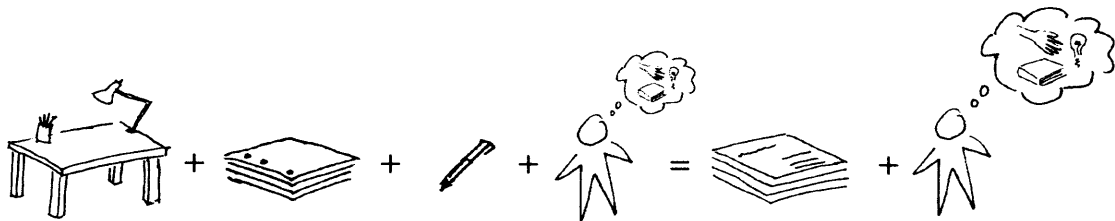

CHAPTER 2. BACKGROUND

“By putting our physical bodies inside our extended nervous systems, by means of electric media, we set up a dynamic by which all previous technologies that are mere extensions of hands and feet and teeth and bodily heat-controls—all such extensions of our bodies, including cities—will be translated into information systems.”

--Marshall McLuhan, Understanding Media

Consider your hands.

Consider all they are capable of: poking, prodding, grasping, waving, holding, squeezing, pinching, tracing. Think of all the things your hands can do ... all they have already done.

Now think about how computers utilize these instruments of wonder.

Just as a person with a hammer sees everything as a nail, computer designers of old are guilty of thinking of people as brains with so many sensory input and output channels. Interface designers speak of appealing to all the senses, but in this age of electronic media, we have been reduced to so many thoughts and commands, our appendages mere strapping points for the electrodes of our bodies electric. The clumsiness of our present day monitors, keyboards and even mice are actually symptoms of faults at a deeper level. Today's computers are designed to communicate, automate, information process, for they are designed around a media paradigm. But are we merely biological processors with neural storage devices trapped in meat cases? We are, therefore we think, yes, but let's not forget that we also *do*.

The arrival of applications that extend beyond the boundary of media, into people's physical lives, will fundamentally change the dominant technologies in computing. Active Workspaces are a product of ideas and technologies from a number of fields. In this section, we will briefly relate the diverse ancestry of this subject area and distinguish it from other similar fields.

The Origins of Active Workspaces

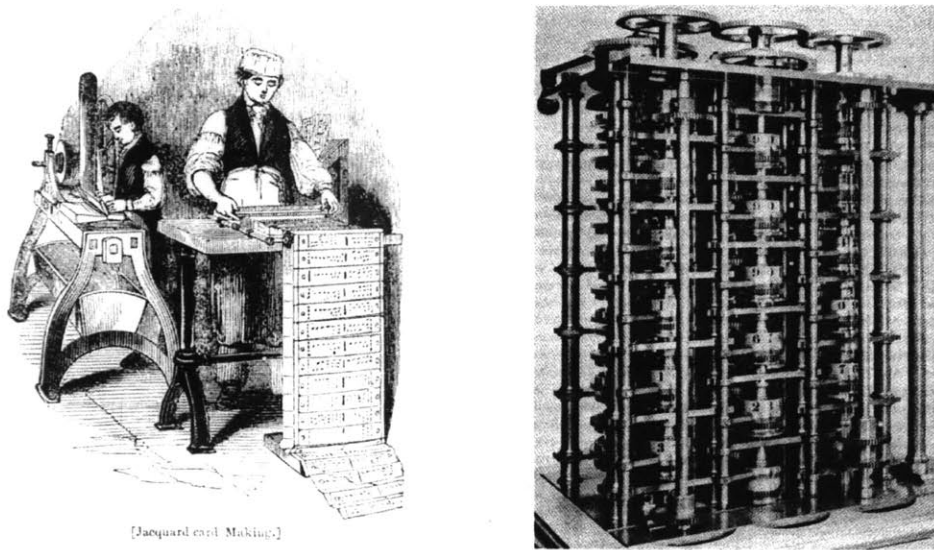

Figure 1. The first computers.

Jacquard's punchcards (left) programmed tapestry, Babbage's engine (right) equations

It is easy to forget that first computers were mechanical: Joseph-Marie Jacquard's 1803 mechanical punch card textile loom was the inspiration for Charles Babbage's "Analytical Engine;" as Ada Lovelace, the first programmer, stated, "We may say most aptly that the Analytical Engine weaves algebraical patterns just as the Jacquard-loom weaves flowers and leaves."¹ Lovelace herself foresaw the wide range of applications computers could be used for, but for the first half of computing history, the only application for computers was, well, computing. Computers *processed*--first numbers, then data and then information. These early computers received input and instructions via punchcards and transmitted more numbers via ticker tape. In contrast, Jacquard's loom and its descendants *actuated*, taking in raw materials and

¹ Ada Augusta Lovelace, as quoted in [32]

instructions and producing finished goods. The first computers and machines were entirely pre-programmed; once the program began, the results were set.

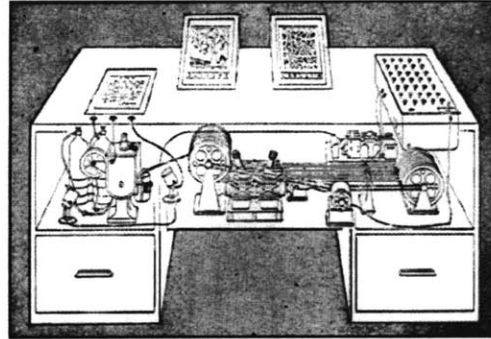
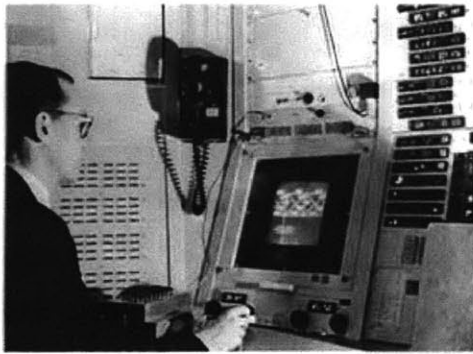

Memex in the form of a desk would instantly bring files and material on any subject to the operator's fingertips. Slanting translucent viewing screens magnify supermicrofilm filed by code numbers. At left is a mechanism which automatically photographs longhand notes, pictures and letters, then files them in the desk for future reference (*LIFE* 19(11), p. 123).

Figure 2. Ivan Sutherland's Sketchpad (left), and Vannevar Bush's Memex Desk (right)

As computers evolved, becoming real-time in speed and plastic in form factor, the potential uses expanded to include media applications. In his 1945 essay, "As we may think," Vannevar Bush detailed a vision of a desk, augmented by computer technologies, with which any book could be "called up and consulted with far greater facility than if it were taken from a shelf." [3] Ivan Sutherland furthered the computer's facility by developing a drawing application, titled Sketchpad, for the TX-2's video console and lightpen interface. [35] These ideas and technologies presaged the dawn of computer graphics, direct manipulation interfaces, networking, data storage and retrieval. At the same time, advances in computer-controlled peripherals made it possible both to automate industrial work and to provide greater power and more sophisticated control to human operators.

Doug Engelbart stated, "Computers do what people want them to do, at best. Figuring out what we should want, in full contemplation of the outspread possibilities, is a task that needs us all, laymen no less." Despite the panoply of technologies—virtual reality, augmented reality, ubiquitous computing—that vie on theoretical or technical grounds for the title of "next generation computing," it is still the applications that determine the course of computer history. Thus, new applications spaces like Active Workspaces are vital to the enterprise of advancing technology and science, and the reunification of the processing, media and actuating paradigms.

Computing Paradigms

In lecturing about interaction design, Bill Verplank [37] commonly starts out with the following sketch:

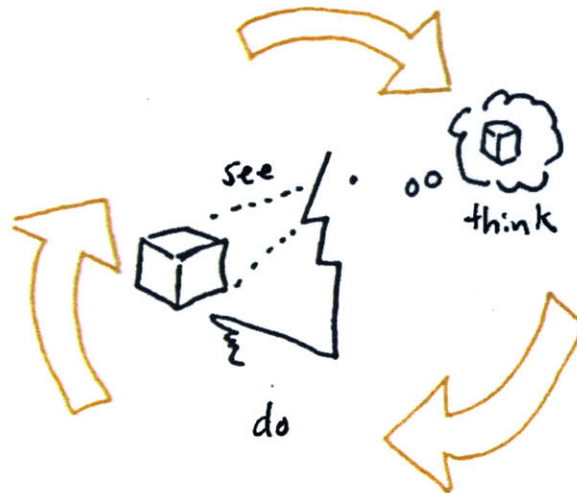

Figure 3. Verplank's interaction diagram

When we interact with an object in the real-world, we employ various modalities, which Verplank represents as seeing, thinking and doing. We are never wholly in one mode or another, but it is when there we switch quickly between modes, when there is a constant synthesis between observation, analysis and manipulation, that we learn the most. By doing, we are learning not only to do, but also to see and think in new ways.

Verplank's diagram is typically followed with that in Figure 4. The key is that each aspect of the computer interaction supports a predominant metaphor for computing that in turn reflects a specific computing paradigm. Those who see the computer as a "brain" are apt to speak of artificial intelligence, an extension of human intelligence, as being the end goal for all this electronic technology. The "media" folk, on the other hand, focus on the computer's ability to transmit information, and view the computer primarily as a means of extending human expression. Those who see the computer as a "tool" that extends our manual capabilities tend to treat computers as a means to create something else. No computer is actually one thing or another, but

these viewpoints strongly color the features of the computer that its creators choose to develop.

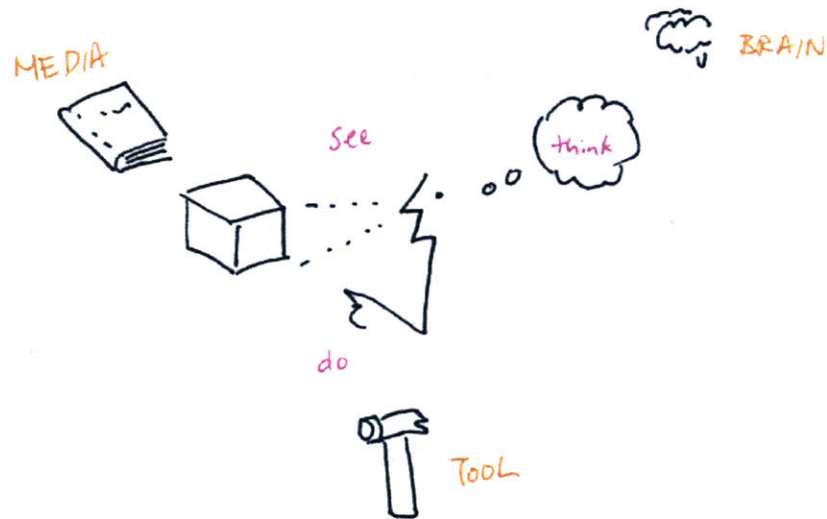

Figure 4. Verplank's diagram of interaction paradigms

How Active Workspaces are not like Brains

The favorite buzzwords of those who espouse the "brain" metaphor for computing are "intelligent," "smart," "agent," and "autonomous." This semantic phenomenon is not an accident; it is a byproduct of the view that computers are separate entities who can act on their own, on our behalf. In using "smart products," there is transference of agency, so it is understood that it is the product that is acting, not the user. Bill Verplank often represents this view as a question of "buttons versus levers." With a lever, the person holding the lever is in control, and is in effect completing the task at hand. If you push a button, there is transference of agency, and a task is done for you.

Many of the technologies required to make Active Workspaces *really* work were developed with this autonomous agent metaphor in mind. For instance, the research on event tracking and inference required by Active Workspaces to observe the user's actions to provide information and feedback was originally conducted to create "genies" or "wizards" in computer interfaces that could assist or automate routine tasks performed by users. These agents, such as the Microsoft paperclip [17] or the

EasyLiving living room [2], used Bayesian user modeling techniques to take data from disparate sensors and infer larger events. Other technologies used by “smart spaces” that are highly useful in the Active Workspace domain are voice and speech recognition and vision tracking. Michael Coen’s Intelligent Room, [5] for example, responds to voiced commands beginning with “Computer,” and uses cameras to help establish context for generic requests like “turn that off.”

One important distinction between these projects and those described in this thesis is that Active Workspaces target activities that we do not *want* to roboticize. The Active Kitchen will not cook for you, and the Active Desk will not do your homework. The problem space addressed by Active Workspaces resides exclusively in the realm where human participation is required, or enjoyed, or desirable.

How Active Workspaces are like and not like Media

The distinction between media and tools is a little more difficult to draw. Active Workspaces utilize media a great deal, and a large variety of media, at that.

However, Active Workspace applications are not media applications, in that the primary output of the Workspace is not data or information. In this way, Active Workspaces are unlike most of our modern-day desktop computer tools, which are products of our computing and media-centered applications. The WYSIWYG word processors and spreadsheets, the e-mail and web browsers, the DVD players or MP3 apps: they are designed to transmit and receive information in all its glorious forms.

This differentiation separates Active Workspaces somewhat from the work of Hiroshi Ishii’s Tangible Media group. Although Ishii’s followers emphasize the need for graspable user interfaces [10] and ambient environments, [41] they are fundamentally concerned with using physical tools to manipulate digital data (hence, “tangible bits”) or embodying digital information in non-digital ways (“ambient media”). They are not yet concerned with producing physical goods, and thus much of their “tangibility” is focused on physical handles or simulated feedback.

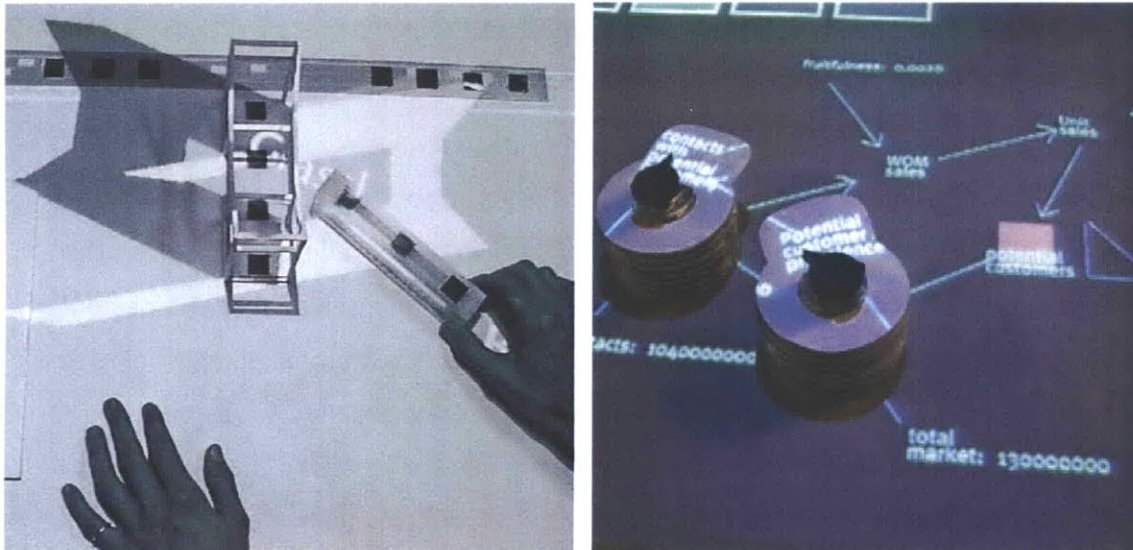

Figure 5. Underkoffler's Urp interface (left) and Patten's Sensable (right)

However, despite these ideological differences, my research inherits a great deal from applications of Tangible Media. Urp, [36] the “luminous-tangible workbench for urban planning and design,” is particularly influential. Its innovative use of horizontal projected interfaces superimposed on tangible tools is duplicated in both of this thesis’ Active Workspace applications. In addition, Urp’s utilization of application-specific tools that are sensed by the workspace is reincarnated in the tools and materials of the Active Workspace. Sensable, [31] billed as a “wireless object tracking platform for tangible user interfaces” shares similarities in arrangement and technology with Active Workspaces, and is likewise concerned recognizing gestural inputs and tracking objects. However, Sensable’s applications center exclusively on media applications such as systems dynamics visualization, interactive art, and three-dimensional model control. Unlike the context-specific tools and materials needed for Active Workspaces, Sensable’s tangible pucks do not vary from one application to the next.

Another set of media worth mentioning is virtual environments. Those working on virtual environments often have workspace-type applications, such as simulated operating tables, underwater environments or aviation equipment. They often utilize three-dimensional modeling and holography, as well as haptic feedback technology, to simulate or augment real-world environments. Nevertheless, these are media applications, even if the media are masquerading as physical tools and objects.

How Active Workspaces are tools (but not like other tools)

Active Workspaces fit neatly into the category of tools, instruments that work to further the abilities of people to do things. They aim to afford capabilities that are more lever-like than button-like, in that they inform, encourage, and celebrate the making of physical things, but they never make things themselves. Today's computer "tools" are fairly limited in form factor. The computer's monitor and keyboard are throwbacks to the television and typewriter, and are generically complemented by an all-purpose mouse. Other tools, such as Wacom pens or joysticks enable more sophisticated modes of manipulation, but are still similarly restricted to pushing, poking and pointing.

Shrinking electronics, new sensors and novel materials have opened the doors to a much wider array of computer tools. The alternative vision of "ubiquitous computing" started at Xerox Parc in 1988, where they outlined a scenario of an office where people interacted with digital information using "tags, pads and boards." [38] Marc Weiser used this as a springboard for the notion of Invisible Computing, stating, "A good tool is an invisible tool... Eyeglasses are a good tool—you look at the world, not the eyeglasses. The blind man tapping the cane feels the street, not the cane. Of course, tools are not invisible in themselves, but as part of a context of use." [40]

Xerox Parc's ubiquitous, invisible computers, (and later IBM's pervasive computers, Microsoft's invisible computers, or the EU's disappearing computers) call for a "seamless integration" between the physical and digital worlds. The Active Workspaces share many similarities in particular to Pierre Wellner's Digital Desk [39], in which typical office tools such as pens, erasers, books and paper were integrated with digital information and virtual tools, and Bill Buxton's Reactive Environments [7], in which a videoconferencing room helped to facilitate remote collaboration. Their demonstrations focused the transfer and modification of digital information, but the accompanying manifestos for each were broad enough to include Active Workspace applications, and their enabling technologies are very much the ones used in Active Workspaces.

One major criticism we can levy towards this prior work into computers that are everywhere, doing everything, unseen to the eye but obvious to the hand, is that they often offer blanket statements of what future computers should be like, what technologies are to be used, and what qualities are good or bad, with little regard to application or scale of the tools. This occurs in part because the previous research tended to focus solely on office-related applications, not unlike those currently handled by conventional computers.

Another aspect of the previous work is that they are often married to particular technologies that occasionally limit the designers' choice of problems. The radio-frequency tags used by Want and others at Xerox PARC, for instance, are wonderfully versatile for identifying objects and will probably be cheap, plentiful and ubiquitous in the near future. [38] However, tags are fairly static; you can read a tag to identify a can as a cream of tomato, but that tag alone cannot tell you if the can is full or empty. Events, such as a fire, or water dripping, or dynamic qualities, like temperature, are difficult to tag. The right technology depends on the situation, and what is needed in general is a repertoire of technologies that suit the wide range of potential applications that exist in the real world.

Key Features of Active Workspace Design

Three primary characteristics of Active Workspaces are that they are application-specific, task-based, and human-centered. This class of applications differs from prior works in that they are designed around specific contexts, are focused on helping people create things themselves, and do not promote any particular type of technology so much as the judicious selection and implementation of a variety of technologies in a coherent manner.

These shared features of different Active Workspaces create similar challenges across different applications. The aforementioned context-specificity demands the identification of salient features of the application at hand; the designer must learn

what tools, materials, processes, and atmosphere are appropriate. Also, because workspaces are heterogeneous by nature, any application design presents the daunting task of maintaining consistency across scale and technologies, the smooth integration of objects in the digital and physical domains. Lastly, there is the need to negotiate the divide between old and new. Encouraging people to engage in physical tasks is in many ways reactionary; doing so with emerging technologies creates the conundrum of deciding what features need to stay the same and which need to change, what behaviors people should keep, and what behaviors they need to learn.

CHAPTER 3. COUNTERACTIVE

"A house is a machine for living in."

—Le Corbusier

Quick—

Where at home do you do your best work?

In the garden?

The kitchen?

Your garage?

The study?

In bed?

We are used to thinking of our homes as the antithesis of our workplaces. In fact, the home can be and often is the environment where people are most creative. At home, unconstrained by corporate pressures and deadlines, everyday people create personal masterpieces for themselves and their families. Commonly dismissed as mere hobbies or crafts, "house work" such as cooking, sewing, woodwork, or gardening, actually provides people with critical skills, physical activity, and improved self-worth. Maybe the strongest indicator of the sacred nature of these activities is the universal revulsion everyone feels to introducing computers to anyplace outside the study.

CounterActive was designed in large part to answer the conventional wisdom that computers have nothing to offer the world of cooking. CounterActive is an interactive work surface built around the metaphor of a cookbook embedded in the kitchen counter. Using a computer, a projector, and a hidden electric field sensor, the counter provides instructions and pictures to teach everyday people to cook various recipes— but also provides movies, music and other tidbits to make the kitchen a more fun and entertaining place to be. As cooks progress through a recipe, they may go

“backstage” at a French restaurant, learn about the origins of those avocados they are using, or be serenaded by a kitschy cowboy. The cook interacts with the counter by touching pictures and words displayed on the image projected onto the kitchen counter; there are no foreign keyboards or mice present to destroy the magic.

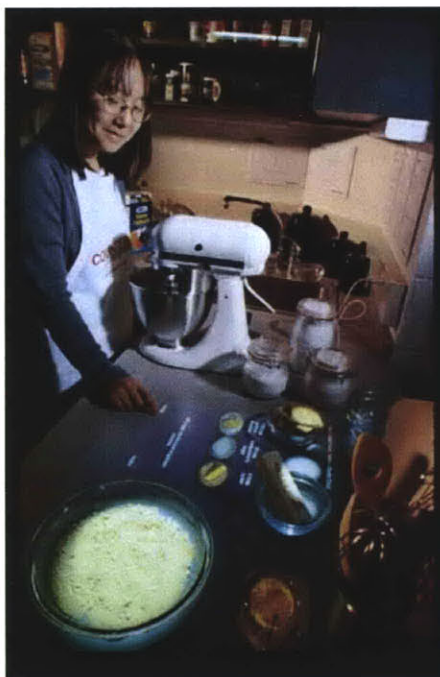

Figure 6. Photo of author using CounterActive to make Berry Tarts

It has become common, if tired, shtick to ask why one's toaster needs a chip, or one's family fridge an LCD. "Likewise," Dave Barry says, "we don't need a refrigerator that knows when it's out of milk. We already have a foolproof system for determining if we're out of milk: We ask our wife." [1] The notion of the wired kitchen has come to represent all that's over-hyped in the so-called Home of the Future. But CounterActive is expressly not a vehicle to introduce computers into the kitchen. It was originally designed with a very real need in mind; with so many families cooking less and less, we are in danger of raising an entire generation of kids who have no idea how to cook for themselves.² CounterActive is aimed straight at the statistics that say Americans are cooking less and less.

² Unfortunately, these questions and jokes are premised on the idea that everything is fine and well in the home of the present. It is not. Just in the kitchen, for example, four out of 10 adults profess to cooking fewer meals at home than a couple years ago. People under 25, who may have grown up in homes where dinner was not a regular ritual, spend 50.6% of their total food dollars on restaurants and

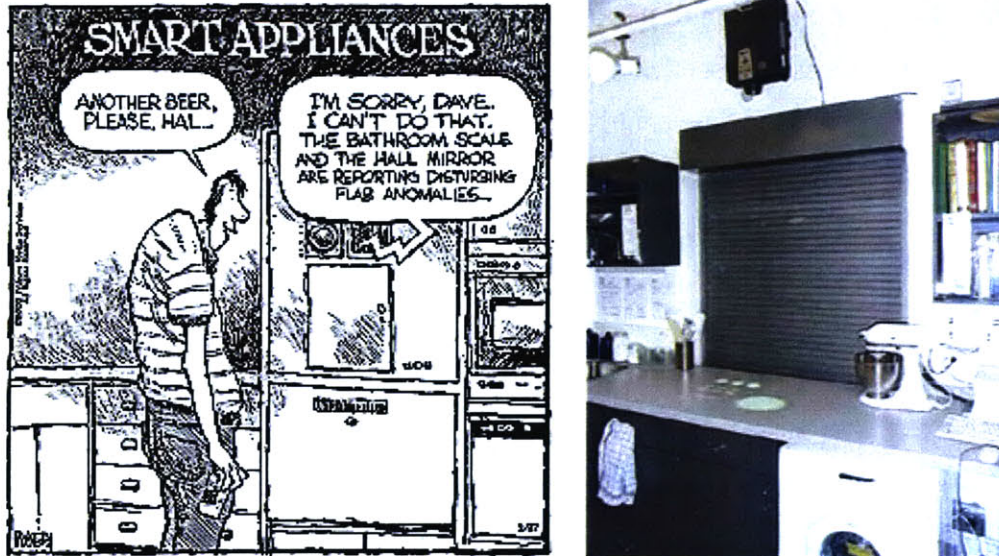

Figure 7. Smart Appliances (left) are nothing like the CounterActive kitchen (right)

Another part of CounterActive's agenda is to change the way people think about computers in the home. For the skeptics, it is important to see a vision of a future home that does not involve Rosie the Robot, or those dreadful words, "home automation." Those who are broadly against the use of technology are usually surprised to discover that computers and robots can assist people, not just replace them.

As for technology enthusiasts, CounterActive underscores how computer technologies need to adapt if they are to succeed in the hostile domestic environment. In order for people to accept computers in the kitchen, and elsewhere in the home, computers need to be application-specific, interoperable, and invisible—the very things that our current generation of computers are not. At home, people work in very specific places, with specialized tools, and the computers in each of these spaces must be designed specifically to each context. Instead of one centrally located, general-purpose monolithic computer tower, work around home demands that there be numerous computers of limited size and functionality that work symbiotically. And, unlike workstations in the workplace, where it is common to expect someone to train and

take-out food. The demographic households most on the rise, single urban dwellers and two-income households, are also the least likely to cook at home on a regular basis. And only 18.6% of households queried stated that they "cooked for fun" in the past 12 months.

devote substantial attention to use a specific apparatus, computers in the home environment must assist users without drawing attention away of the task at hand. Hence, the kitchen is a prime context in which to begin our experiments with Active Workspaces.

Previous Work

Surprisingly, the first computer commercially marketed for home use was a kitchen computer. The Honeywell H316 Kitchen Computer was prominently featured on the cover of the 1969 Neiman Marcus catalog. Priced at \$10,600, the streamlined red and ivory apparatus came with an integrated cutting-board platform, an apron, and a two-week training course for the lucky lady who owned it. This ostentatious product is commonly cited as a commercial failure, yet it is doubtful that Honeywell ever intended it to be more than a gimmick. Nevertheless, the Honeywell H316 gave birth to the notion that computers might one day be of use to everyday people in their homes.



Figure 8. "If only she can cook as well as Honeywell can compute.":
Honeywell's original 1969 ad for the Kitchen Computer

Commercial kitchens of the future

Since Honeywell's Kitchen Computer, the kitchen has been what Kevin Maney of USA Today calls the "Bermuda Triangle for computers." [27] Many companies have attempted to create consumer products for the kitchen, yet none have succeeded. Notable examples of late include Electrolux's ScreenFridge, 3Com's Audrey, Netpliances i-opener. All of these products present recipes, organize family schedules and give people Internet access in their very own kitchens. They feature tablet sized LCD touch screens and come in very kitchen friendly colors and finishes. However, Maney notes, these kitchen computers are still too hard to use, too big and ugly and don't solve any problems. "It won't take out the trash or make sandwiches or scrape burnt sticks off the baking pan. What good would it be, then?"

It would be a mistake to dismiss kitchen computers outright on this basis, for these newest generation of kitchen computers have made the same grave errors that their predecessors, going all the way back to the Honeywell, made. These general-purpose computers, even embodied in new form factors replete with laptop displays and nifty stylus wands, demand prissy interaction styles that are wholly inappropriate to the messy and organic kitchen environment. Another pitfall in both illustrated designs is the use of windows, menus, and icons in the interface that inappropriately makes users feel as if they are using Microsoft Excel when they're having cereal for breakfast or preparing chicken for dinner.

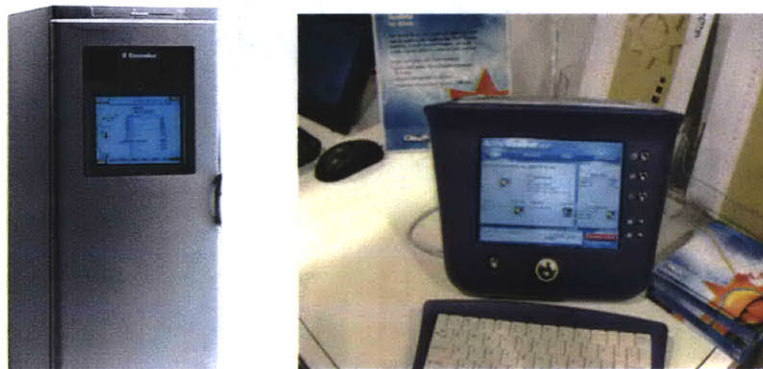

Figure 9. Electrolux Screenfridge and 3Com's Audrey

Academic and Research Kitchens

The scholarly brethren of CounterActive have fared somewhat better, if only because academia is a more appropriate forum for interesting experiments that are likely to be financially unprofitable. The goal of academic projects set in the kitchen is not commercial success but applicability, universality, comprehensibility, reality check.

Artificial Intelligence researchers have long had a soft spot for using cooking and food-related applications as toy problems. Kris Hammond at University of Chicago used recipes as a metaphorical basis in his detail of a Case-Based planning system, CHEF. [14] Henry Kautz and James Allen from University of Rochester used the making of pasta as the central example for their paper on "Generalized Plan Recognition." [21] David A. Mundie, who teaches at the University of Pittsburg, has extensively analyzed various recipe formats and developed a "programming environment for the kitchen" named Cocina in order to generate new recipes, analyze nutritional content, cost or complexity, create shopping lists, suggest menus and manage inventories, among other things. [28]

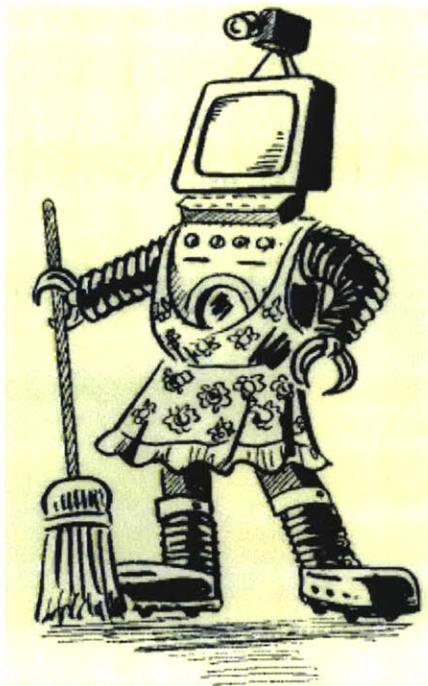

Figure 10. The common conception of a kitchen computer

However, none of these “toy” systems were ever intended for use in real kitchens. The cooking scenarios just lent themselves nicely to the programming mindset, for after all, recipes are just programs for people, and they provided accessible problems that audiences could easily relate to. However, none of the numerous planning algorithms or learning techniques that used cooking scenarios were ever meant seriously to be used by people in the own kitchens, primarily because the technology to allow such use was incomplete, because no proper interface was ever created for such use, and most importantly, because people were pretty happy cooking in the kitchens without the presence of any so-called intelligence.

These days there are numerous groups working on diverse computer-enhanced environments. Many, at University of Toronto [7], Stanford University [11], and Xerox Parc [9] are focused on creating interactive conference rooms or offices. Others, such as the Georgia Tech Aware-Home [24], MIT AI Lab’s Intelligent Room [5], or Microsoft Research’s Easy Living project [2], are centered on domestic environments, but are researching the entire home or just living rooms. These projects are largely technology focused, as opposed to application focused. Most of the home projects tend to rely on vision or speech recognition for world or user modeling. This projects’ use of distributed heterogeneous sensors are a cheaper and more effective way of monitoring events and gauging the user’s actions; it is possible that these mechanisms might complement or supplant vision or speech systems.

Finally, the home has been given a more human-centric perspective by designers and architects. Students at the Rhode Island School of Design’s Universal Kitchen project [25] developed ideas such as modularized dish drawers that automatically wash the dishes and height-adjustable counters. Casablanca, a home-based computing project at Interval Research, investigated using computers to make new social communication devices. [15] This research emerged from ethnographic studies of people in the home which lead to prototype devices that ultimately led to work on wireless technology applications for the home. And Kent Larson of MIT’s House_n is focused on using

computing technologies to provide home-based preventative medicine to an aging population. [26]

Counter Intelligence at the MIT Media Lab

CounterActive is only the latest in a long line of kitchen applications from the MIT Media Lab's Counter Intelligence project. Marco Pollo [22] utilizes simple tagging and barcode techniques to allow your food to tell you a story about itself. A tagged bag of Thai rice, for example, pops pictures of rice paddies in Thailand, and a map showing you where Thailand is. Sticking your tagged coffee cup under Mr. Java's [23] spout in the morning, and it would automatically dispense your favorite coffee beverage and play your preferred radio news. The Networked Kitchen [13] would walk a cook through the preparation of a chocolate chip cookies using audio, and save the cook from having to measure through the use of a networked scale embedded in the counter and tags in the ingredient jars.

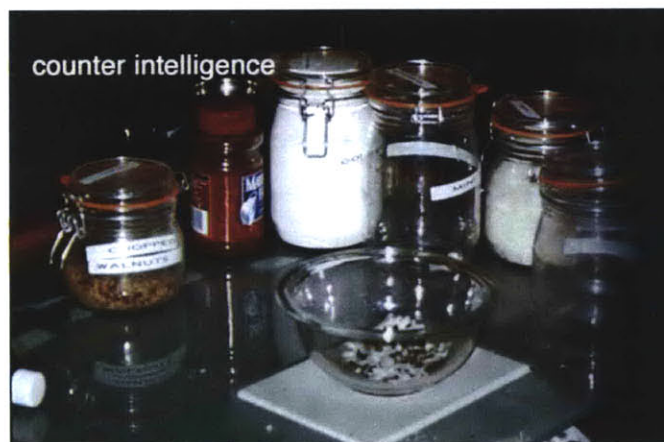

Figure 11. The Networked Kitchen, a.k.a Kitchen Sync

System Description

The CounterActive is embedded directly into a counter in the Counter Intelligence kitchen at the MIT Media Lab. The CounterActive recipes, written in Dynamic HTML and displayed using a web browser, are projected directly onto the kitchen counter, thereby creating a 28"x 20" display which is impervious to the spills and messes inherent in cooking. Instead of having a keyboard and mouse, we use a two-dimensional electric field sensing "tauFish" array mounted beneath the counter so that users can interact with the projected interface, somewhat like a touch screen.

Finally, feedback, words and music are played through a speaker system mounted above the kitchen's cabinets.

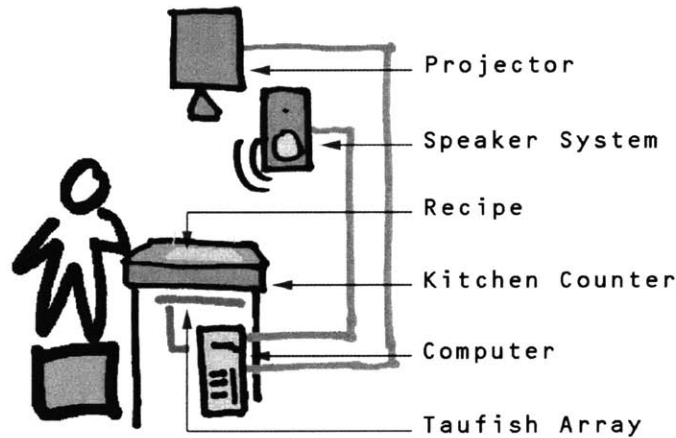

Figure 12. Picture and Diagram of the CounterActive System

Ingredients and Tools for CounterActive	
Physical installation	Epson Powerlite 7350 Compaq Athlon 1 GHz PC Filament Serial to Ethernet converter TauFish Scenix SX28 microprocessor based Electric Field Sensing Array
Content	HTML pages Mpeg video Still images Sound files
Software Languages	Java 2.0, Javascript
Content Authoring Tools	Dreamweaver 2.0 Internet Explorer 5.0
Digital video and film tools	MiniDV, Final Cut Pro, Photoshop 5.0, Apple G4

The physical setup of CounterActive borrows heavily from the Interactive Furniture created by the Media Lab's Physics and Media group for the Un-Private House exhibit at the Museum of Modern Art in New York. [30] CounterActive differs from the Interactive Table from a research perspective, for CounterActive is not a kiosk but an active workspace, which the users are to cook on. This is an important distinction.

The spatial nature of the setup was used In the MOMA exhibit to create a feeling of familial intimacy with other museum patrons, whereas CounterActive uses that spatial quality to choreograph the cook's movements in space.

The Design of CounterActive

The idea for CounterActive came out of a scenario called Kids in the Kitchen. Kids in the Kitchen focused on using technology to provide kitchen access to children, a population increasingly kept out of the kitchen because of safety and ergonomics concerns. In this scenario, we tried to envision a future kitchen that could identify that a child was in the kitchen and adapt itself enough so that the kitchen be a fun and safe place for a child.

The Kids in the Kitchen scenario

This future kitchen would have distributed sensors throughout that would help the environment infer who was in the kitchen, and what they might be doing. It could, for instance, distinguish between a person opening a fridge to stock it and a person who was opening a fridge to take a snack. It might, by detecting that pots and pans were being used, guess that someone was starting to cook and quietly suggest recipes or prepare the oven or stove as needed. The important feature of such an environment is that it would act on detected events, not just explicit commands. This enables people to go about their business in the kitchen in the usual manner, instead of having to command their kitchen like the Starship Enterprise.



Figure 13. The Kids in the Kitchen scenario

Such a kitchen might be particularly good for children, who do not grasp full of the kitchen's capabilities and hence are not in a position to issue commands. After establishing the premise of safety (the kitchen could, after all, lock the cabinets where it knew of sharp objects or dangerous chemicals) we went about investigating other limitations to children's access to the kitchen. There were basic ergonomics issues: the counter is too high, the doors are too wide, and most importantly, the tools were

designed for adult hands. There were functional concerns: perhaps we could modify the oven to include the warm up and cool down times in its cooking, for children who should not reach into a hot oven alone. However, we decided that the most prohibitive factor in kids not cooking is the fact that these days there is not usually someone in the kitchen to learn *from*—and the fact that they are not proficient readers keeps them from learning on their own.³

The initial program for CounterActive, then, was simply to present an interface to recipes that utilized pictures and videos to communicate what to do, broke down instructions into a purely linear order, and that read what words were needed aloud. We sought to improve on previous kitchen computer work by being interactive, entertaining, and most importantly, encouraging users to cook in a real kitchen, and to produce real food.

Interaction design

Projecting the interactive display on the horizontal surface of the counter, into the cook's working area, reduces the divide between seeing and doing that exists in traditional media such as television cooking shows or online cookbooks. We take advantage of the setup by using the physical layout of the cooking interface to help choreograph the cook's actions and organize the process. The interactive nature of the media allows the user to go at their own pace, and to customize the recipe to match their level of expertise

Interactive recipe design

The *CounterActive* cookbook consists of Dynamic HTML recipe pages viewed in a web browser. However, the recipes are specifically designed not to resemble web pages—or any other familiar computer interface. The CounterActive cookbook does not use windows, icons, menus or pointers at all— to differentiate the experience of using the kitchen to cook from the experience of using a computer workstation.

³ Note: This is merely a vehicle towards an interesting design space. We are not actually advocating that children cook alone in the kitchen. Please do not try this at home.

The spatial layout of each recipe includes interaction, video and work areas. The interaction area is where users interact with the counter by touching written instructions and relevant pictures. The video area presents pictures, instructional videos, and entertaining movies relating to the recipe. The work area is where the user prepares the food. We used visual cues such as color backgrounds and spotlights to differentiate the separate areas. Sound is incorporated throughout the user experience to provide instruction, feedback and ambiance.

We studied popular cookbooks, CD-ROMs, gourmet magazines and cooking shows at length to understand the visual language and style of the kitchen domain. Our observations were the basis for several sets of recipes. Each set of recipes explores different styles, schemes and layouts. All in all, we created four “recipe programs” for CounterActive. Descriptions of each recipe—and the steps we took to make them—follow. Screenshots from the recipes are available in Appendix A.

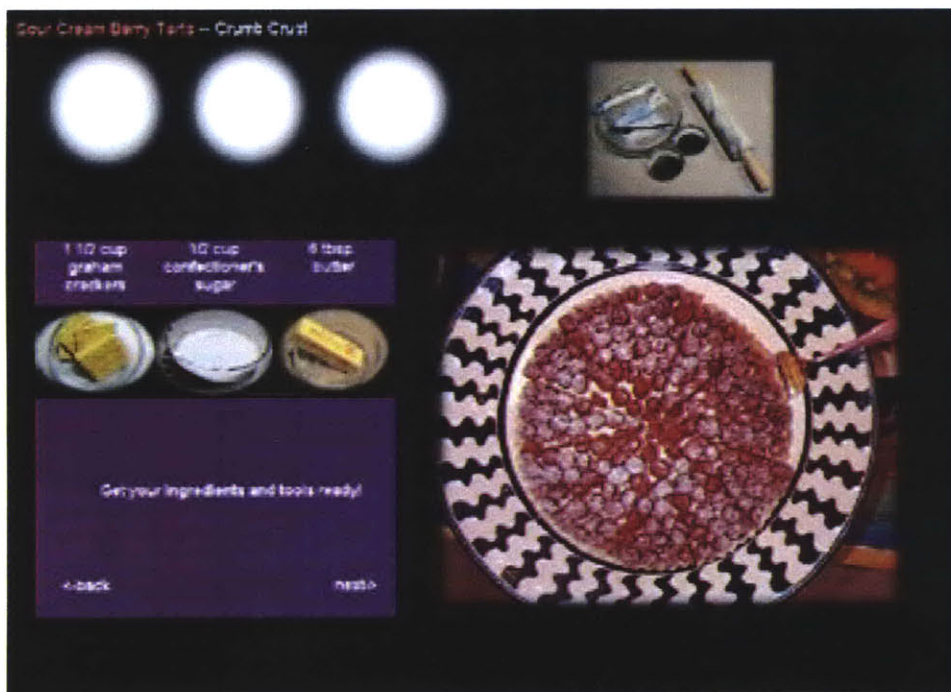

Figure 14. Screenshot from Sour Cream Berry Tarts

Sour Cream Berry Tarts was our first recipe and most demonstrated recipe. It was chosen because it could be prepared with few ingredients and no knives. We recorded sound clips that “read” written text aloud when touched, and included short videos for the steps demonstrating how to crush graham crackers and fold sour cream. The

interface layout for this recipe was the most diagrammatic. Because we were just defining the rules of the interface the designated interaction, display and work areas were very explicitly delineated. Long after we had more entertaining and good looking recipes, we would return Sour Cream Berry Tarts to show people the basic interface principles at work.

Banana Bread was an experiment in using fonts, color and arrangement to create a more fun atmosphere. Again, the recipe was targeted at children, and was chosen both for its safety and its low work/reward ratio. Because visitors reacted very positively toward the idea of using video clips to demonstrate steps, we incorporated far more of the instructional movies and targeted them toward kids, taking care to demonstrate, for example, that one should wash hands before cracking eggs since you will inevitably have to fish shells out afterwards.

South of the Border was a departure from the concerns of the previous two recipes. Many visitors of CounterActive commented that the counter would be useful not only for children but also for adults, and that could not only show instructions but also entertain. Thus, South of the Border was envisioned as a party helper for adults, putting them in a festive mood while they make simple snacks of guacamole, salsa and margaritas. The theme was Mexican-American kitsch, and hence we recruited our fellow graduate student Matthew Debski to star as a poncho and cowboy-hat wearing gringo who would appear on your counter to tell you trivia about the origins of avocados or experiments you could try with your salsa. Mariachi and salsa music help to foster the funny and festive atmosphere

French Getaway showcases what the CounterActive kitchen can really do. This set of recipes leads adults through four dishes that comprised an entire French meal. Each recipe was tied to some aspect of France: the markets, the cellars, the countryside, and the restaurants. We used videos, digital pictures, interesting trivia and a jaunty French soundtrack to help bring the ambiance of Provence to the Counter Intelligence kitchen. Using food photography and digital video skills we acquired through Kraft Foods and Nickelodeon studios, respectively, we ventured to Kathy Alex's cooking

school in Provencal France to create a recipe program that was better than any cooking show. We filmed the making of one recipe each day, replete with detailed instructions featuring three camera angles, and “fun fact videos” wherein Kathy would explain how to pick melons or how to cut a chicken into eight equal pieces.

The tauFish array

The use of the tauFish field-sensing array was motivated by the fact that the tauFish is mounted invisibly under the table. This makes it easy to retrofit any existing horizontal surface into an interaction area. We paired two sets of tauFish array to create a 20”x 28” sensitive area under the projected display region on the counter. The arrays were mounted with Velcro and fit nicely in the vertical area above the kitchen drawers. Additionally, the hiding of the sensors make the tauFish a viable technology for the kitchen, where spills and messes make keyboards and mice completely impractical.

tauFish operating characteristics:	
Sensitive area	20”x 28”
Vertical range (from countertop)	~1.5”
Spatial resolution	~3”
Power budget	6 amps @ 6V

Figure 15. CounterActive tauFish operating characteristics

We found the tauFish to work quite well in general, though we discovered through our user tests that it often takes people a little time to get used to using their whole hand to gesture on the workspace. The tauFish did not react to liquid spills on the counter, perhaps because the quantities spilled were usually small relative to the capacitance of the human body. We did find, however, that the tauFish’s sensitivity would vary over the course of the day, due to changes in humidity in the kitchen; we recommend that future tauFish incorporate a humidity sensor to dynamically vary the sensitivity to create a more consistent response throughout the course of the day.

Tags and tools

Since food items are likely to be sold with electronic ID tags [2] instead of bar codes in the near future, we explored technology that enables the counter to track ingredients over the *CounterActive* counter, and to create tagged tangible tools that cross the digital divide.

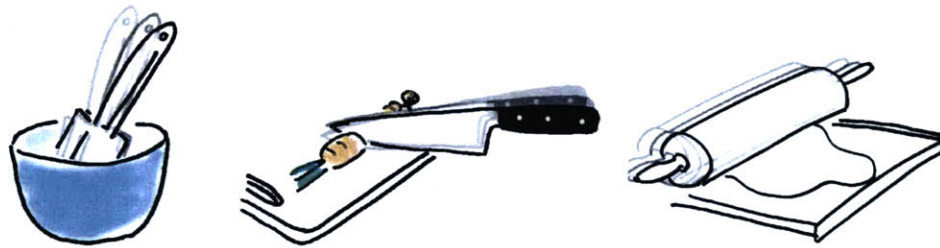

Figure 16. The kitchen is home to many tools that can reveal the user's actions

We pursued the idea of a rubber spatula that can track a user's motions well enough to detect whether the user is mixing instead of folding, for the difference between mixing and folding is the difference between light fluffy meringues and hard lumpy rocks, between a fluffy soufflé and a fallen one. The sense-able spatula was designed with two "active" radio-frequency tags built either end of the handle, so that by detecting both tags, the kitchen computer could infer the movement of the spatula in space. The active tags differ from the passive tags used in the previous Counter Intelligence demos in that the tags themselves have processors on them. Fellow graduate student Matt Reynolds came up with the idea of having the tauFish on the field sensing array broadcast grid coordinates, which the tags would sense and in turn broadcast back to the kitchen computer. At the time of this document's printing, this research was still in progress.

Evaluation

CounterActive has been in continuous "demo mode" since it was first created in October of 1999. As it was very popular on the Media Laboratory demo circuit, we

have received copious comments, criticisms and compliments on the counter. As noted in the descriptions of the various recipes, many of the improvements made to the content and operations of the counter originated from suggestions made by sponsors, visitors and fellow students at the Media Lab. In addition, we published a short paper on the setup, design and test of CounterActive at SIGCHI 2001, entitled "CounterActive: An Interactive Cookbook for the Kitchen Counter." [19]

This evaluation section is broken into three parts: conceptual evaluation, heuristic inspection, user testing. The *concept* of CounterActive has been well publicized, and we first briefly capture a few comments to indicate the general response to the idea of having a kitchen help prepare food, and the larger idea of computer systems that help people do things themselves. Although CounterActive is targeted at amateur cooks, we have found the feedback of professional cooks, cookbook writers and graphic designers to be particularly valuable; we review some of the insights provided by such experts after viewing the interactive counter. Finally, we review the results of our more formal design verification testing with children and adults to both test the design principles behind CounterActive setup and to our own assumptions of how users might operate with such a system.

Conceptual evaluation

General response to CounterActive is overwhelmingly positive. Most mention that they are drawn to the non-intrusiveness of the system, because it's "just like a normal kitchen," and "you're the one who is really cooking," to share two common comments from people who expected to see something out of the Jetsons.

The notion of a talking kitchen counter has attracted a great deal of press attention,⁴ and several corporate sponsors⁵ have expressed serious interest in recreating CounterActive in a commercial product. Frequent suggestions for future developments

⁴ See [16],[20],[34],[6] for a limited sample.

⁵ including McDonald's, the world's largest fast food restaurant, Kraft Foods, the largest branded food and beverage company in North America, Stop and Shop, the largest food retailer in New England, and Merloni Elettrodomestici, a European white-good manufacturer

include having the kitchen automatically shop for ingredients, having companies pay for content to be streamed to user homes, assisting families for large cooking events which require greater temporal coordination, such as Thanksgiving dinner, and the addition of other output modalities, such as smell. To these companies, CounterActive represents an opportunity for companies help shape the overall consumer experience, and marks a viable application domain for broadband in the home.

Heuristic inspections

Visits to the Counter Intelligence kitchen from a variety of well-known cooking and design professionals have furnished us with numerous expert opinions on CounterActive. Jacques Pepin⁶, Patrick Boisjot⁷, Jose Andreas⁸, and Kenneth Oringer⁹ were among the professional chefs who examined CounterActive and gave feedback on the use of such technology to teach cooking. From their perspective, the highlight of CounterActive was that it was situated in the kitchen, not the living room as cooking shows are and that would-be cooks would learn while cooking themselves, much as professional cooks do in cooking schools. An expert in balancing the need for information, demonstration and entertainment, Pepin approved of the evolution of our recipes from pure instruction to a format that focused on fostering the proper atmosphere and ethos to motivate people to cook in their own homes. Andreas and Oringer were of the vigorous opinion that CounterActive should be implemented in professional restaurant environments, where dynamic and up-to-date information about the daily specials, ingredients and garnishing information at the point of work would greatly ameliorate the challenges of managing large cooking staffs of various skill and experience.

⁶ well-renowned as a chef, food columnist and television show host

⁷ a chef who teaches cooking courses at University of New Hampshire over closed-circuit television

⁸ the executive chef and partner at Cafe Atlantico in Washington D.C.

⁹ executive chef at the restaurant Clio in Boston

User tests

In the spring of 2001, we conducted a series of user tests to verify our design assumptions and decisions.¹⁰ Two children and five adults used CounterActive to complete an entire recipe, and answered interview questions about their experiences. The recipes each subject were asked to prepare were geared for their skill and age level. Our testers included two children, ages 10 and 7, four college students (three male, one female) and one older adult. Each session took two hours with the pre-cooking and post-cooking interviews. The limited numbers of test participants was due to the substantial length of time required to complete any recipe, and to the expense of effort required to equip the kitchen with the ingredients needed for such a task. Detailed descriptions of the testing procedure are described in Appendix B.

Our testing indicates that users of all ages enjoy the experience of cooking with the counter interface, and that they are particularly drawn to the entertainment aspects of the content design. However, our most profound result was the discovery that people who are insecure about their cooking ability will often play instructions several times throughout a step to hear the sound clips, to observe different aspects of the instructional video—even after they have completed the task!—just to reassure themselves that they have done the right thing.

Future Implications

As this is a concept piece, CounterActive has been very effective at countering the “Jetsons world view” that robots should do everything for us in the future. We feel that it embodies desirable qualities of interactive environments as laid out by Cooperstock, *et al.* [7] CounterActive is “invisible” because the user is focused on the task above the counter rather than on the interface itself. It allows the user to control the pace of the process, and to get information when he or she needed it. Feedback is provided through sounds and changes in the interface.

The user testing suggests, however, that to really teach cooking and provide adaptability, the CounterActive system needs to detect the user’s actions. To this end,

¹⁰ approved by MIT’s Committee on the Use of Humans as Experimental Subjects, #2706.

we will be using tagging technology to monitor tools and ingredients as users cook. Also, *CounterActive* strongly suggests the need for a more connected kitchen, where your oven knows how long to cook a dish because the counter tells it what recipe you are working on, or where the contents of your cupboards determines what recipes you see.

All in all, *CounterActive* illustrates how the appropriate mapping of layout, progression, feedback, style and context to the needs, tasks and actions of the user are critical in the design of interfaces for interactive environments in general.

CHAPTER 4. ORIGAMI DESK

“Designing settings is an art. It requires a person to visualize and create a mood. He must be practical in placing entrances and exits and be considerate of actors who will populate the settings. He must be an expert at stage lighting, the greatest magic at his command in creating a world of make believe.”

--Henry Dreyfuss, *Designing for People*

Origami Desk is an interactive environment where users learn to fold paper into beautiful shapes. The goals of Origami Desk were two-fold: first, to teach users origami and second, to convey the notion of Active Workspaces to the casual visitor. Thus, the design of Origami Desk not only uses computers and sensors to help people learn to do things outside the digital domain, but also does so in such a way so as to be transparent and indicate to patrons how and why such a system might be built.

We presented the Origami Desk installation at the Emerging Technologies exhibition of SIGGRAPH 2001 from August 12th –17th in the Los Angeles Convention Center. [18] Because Origami Desk was created from the start as a public exhibit, we began by thinking how we could convey our message not only to those who hunkered down and folded a crane, but also their friends who might be standing by watching, the curious geeks who wanted to see the inner workings of the system and even mere passersby.

The design of Origami Desk was multi-disciplinary and multi-layered. The installation involved elements of architecture to help create the context for the folding, graphics and multimedia design to help guide the user through learning the folds, and sensor design to develop ways for the system to interact with the user implicitly and explicitly.

One particularly innovative aspect of the Origami Desk design was the use of passive Electronic Article Surveillance (EAS) tags in the origami paper in combination with a swept radio-frequency (RF) sensor embedded under the work surface to monitor the folds of the origami paper.



Time played a significant factor in Origami Desk's design. The idea for Origami Desk began in January 2001, and full-scale implementation plans did not begin until after our project proposal's acceptance in April. As such, many of our design decisions, such as the specific fold sensing mechanisms, were driven by what could be done in a reasonable time frame without compromising the primary objectives of the project.

The Origami Desk team was comprised of graduate student Leonardo Bonanni from the Department of Architecture's House_N, undergraduate researchers Rebecca Hurwitz, Tilke Judd, and Jennifer Yoon and fellow Media Laboratory graduate students Richard Fletcher, E. Rehmi Post, Matthew Reynolds and myself. Although each person was responsible for different parts of the implementation, the design of the Origami Desk system was very much a team effort, the product of many protracted but fruitful debates.

Previous Work

Origami Desk was originally conceived as a way to generalize the ideas behind the CounterActive project, and to illustrate the idea of Active Workspaces to a larger audience in an exhibit setting. Origami is similar to cooking in that it is a linear process that many people could use help with, but is more tractable in exhibit settings because of its sparseness of material (paper) and simplicity of task (folding). Origami is not widely associated with any particular environment, but creating a context that fosters the right atmosphere was one of Origami Desk's architectural challenges.

The elegance of origami has a surprising number of fans in the computer community, and hence Origami Desk is only the latest in a long line of computer-assisted origami programs.

Iogami and other animated origami software

Iogami is a Macromedia Flash program written by Casey Reas at io360 that demonstrates how to fold a variety of origami birds. [33] His is the most graceful example of the numerous multimedia origami tutorials we encountered in our benchmarking process. Reas' primary technique is to highlight the leading edge and show an animation of the flaps folding.

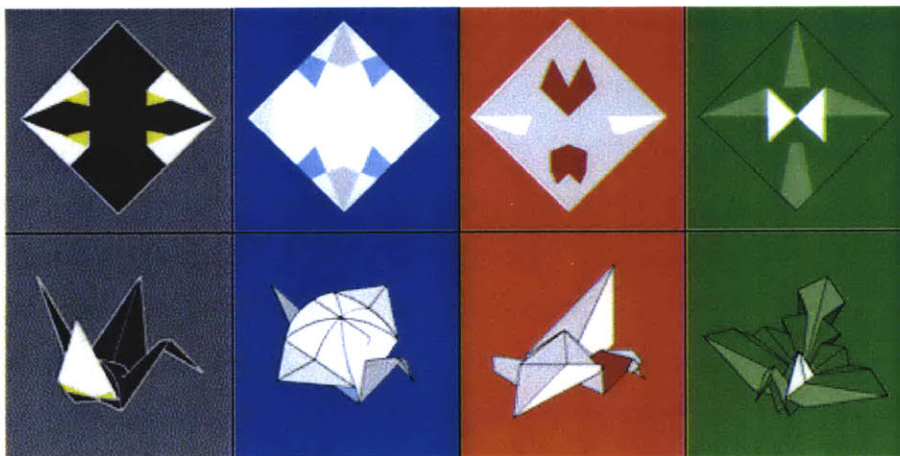

Figure 17. io360's Iogami, designed by Casey Reas

Other similar software tutorials are available on CD-ROM or online, and commonly feature trivia about Origami ("The word is Japanese, literally meaning 'to fold' (oru) 'paper' (kami)"), as well as video and pictures to guide the user through the steps of folding.

We benchmarked several of the online origami web pages, and purchased a highly-recommended CD-ROM to mine these for both positive and negative examples of how to construct our tutorial interface.

The Origami Electronic Performance Support System

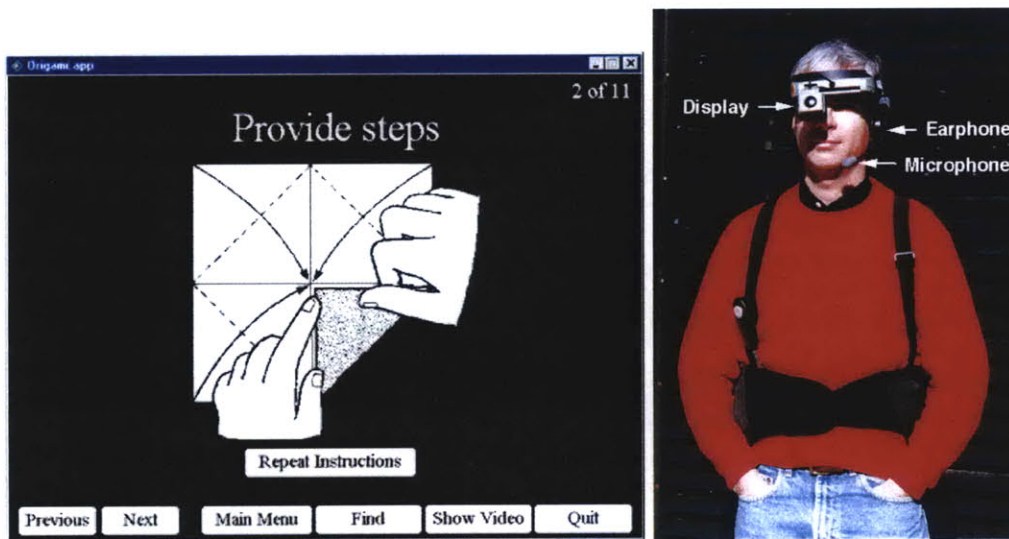

Figure 18. Interface and wearable hardware for Georgia Tech's Origami Support System

Researchers at the Georgia Institute of Technology used an origami application to test the viability of using a wearable computer to teach people tasks with just-in-time information. [29] They compared their interface to that of book with folded paper diagrams. They found, to their surprise, that people generally preferred using the book to the computer. Many of their users indicated that they would be willing to use the system on a desktop computer but did not like using the head-mounted display.

Although we took issue with the interface design of the Origami Electronic Performance Support System, as well as with the use of encumbering wearable technology in such an application, we deeply appreciated the methodology used by the

Georgia Tech research in the evaluation of their system. We emulated aspects of their testing process in our own user tests described later in this chapter to obtain both objective and subjective metrics of Origami Desk, as well as a comparison to other similar tutorial system.

HyperGami

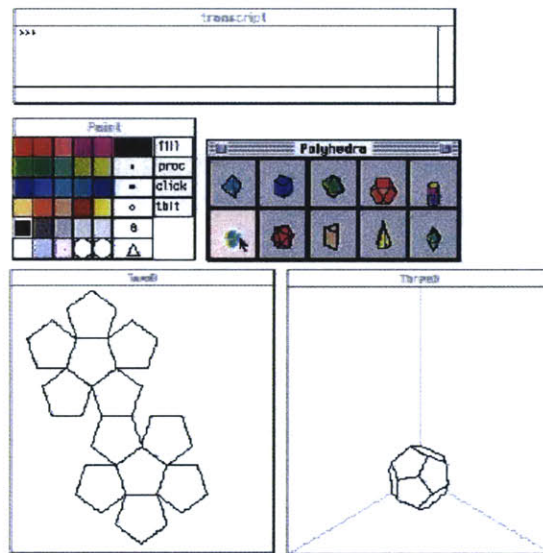

Figure 19. Screen shots from Eisenberg et al.'s Hypergami interface.

HyperGami is an educational program that helps guide children through the design and construction of mathematical models, which are printed out and folded into paper sculptures. [8] Its goals were to find ways to “integrate the “high-tech” features of computation with the “low-tech” features of traditional craft materials in education.” HyperGami shares the Active Workspace ethos that rejects “the rhetoric of ‘virtuality’” that pervades much of current educational computer applications for “ a future in which the material world itself is a richer place, filled with new stuff for our collective hands and minds to play with.” However, the Hypergami software creates a two-part interaction, one where the user designs the three dimensional polyhedra to be folded on the screen, using a mouse and keyboard, and another after the pattern is printed out and the user can cut out the design and fold the shape.

System Description

The key characteristic of Origami Desk that sets it apart from previous designs is that it aids the user in an environment suited to origami folding. Origami Desk utilizes projection, electric field sensing, and low-cost radio-frequency security tags inherited from previous Active Workspace designs to enable computers to break free from the CRT-keyboard-mouse interaction paradigm. These technologies allow interactions to transpire in the user's space, eliminating the need for the metaphoric mapping between the digital world and our physical one, and distancing the interaction from the computer interactions typical of the home or office.

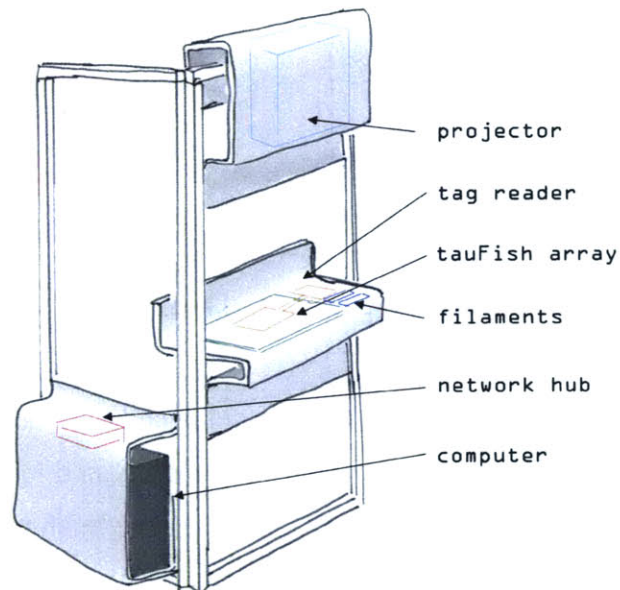

Figure 20. Diagram of Origami Desk system components

The Origami Desk setup consists of an overhead projector, custom-designed swept-frequency tag sensor hardware, capacitive electric-field sensing hardware, and a computer. The tag sensor hardware monitors the tagged origami paper, while the field sensing hardware tracks the users' hands over the work surface. The sensors and computer communicate via UDP over a 100Base-T network by way of serial-to-Ethernet converters and a network hub. The data from the tag sensor and the electric-field sensors are processed by custom-written software programs, and the interface is

designed using Dynamic HTML pages whose behavior is controlled by JavaScript programs.

origami desk system diagram

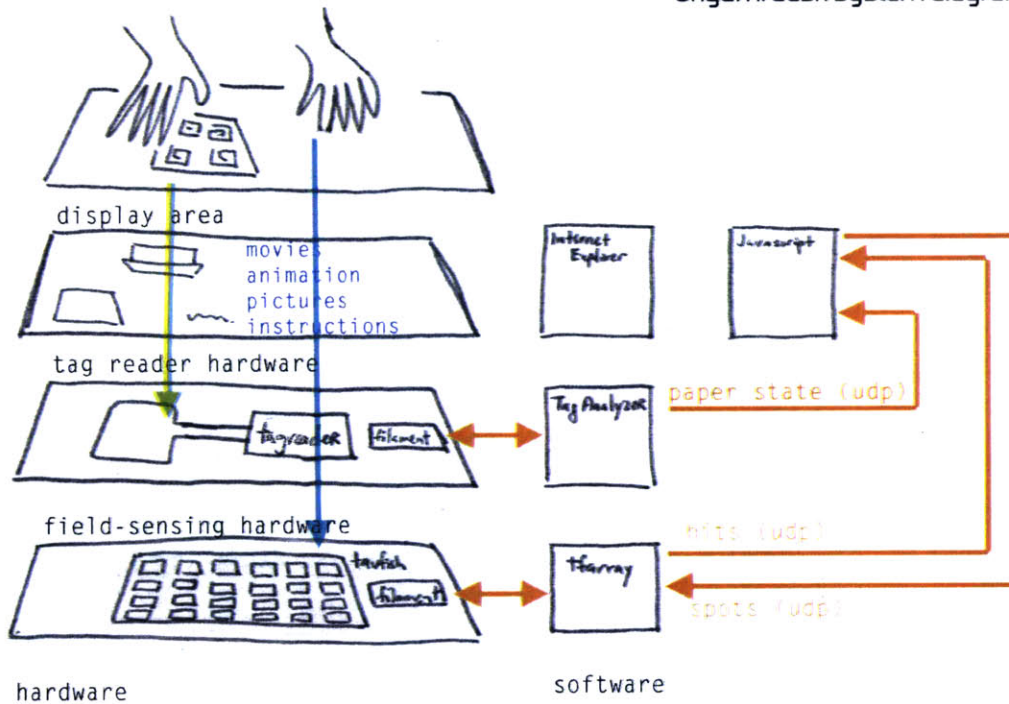

Figure 21. Origami Desk system hardware and software schematic

The Design of Origami Desk

Interaction design

Origami Desk was designed to entertain a variety of users: old people, young people, tall people, short people, handicapped people, technical people and laymen, international people and locals. We were interested too in engaging our audience at different levels. The diagram in Figure 22 shows the range of users we were targeting in our design.

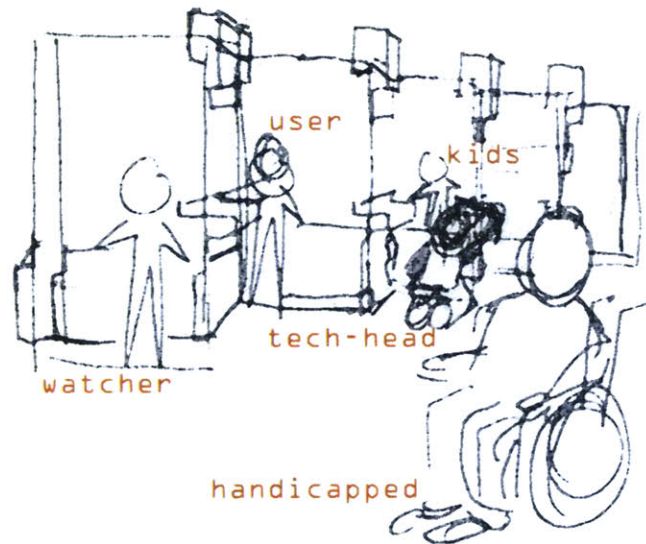

Figure 22. Sketch of different users targeted by the Origami Desk system

The design of Origami Desk encompassed many different scales, disciplines and technologies. We strove to unify the different components of the system with the underlying themes of *translucency*, to show not only application but also its underlying technologies, *adaptability*, to highlight the need to cater to different audiences, and *elegance*, to match the spare simplicity of origami itself.

Fold sensor design

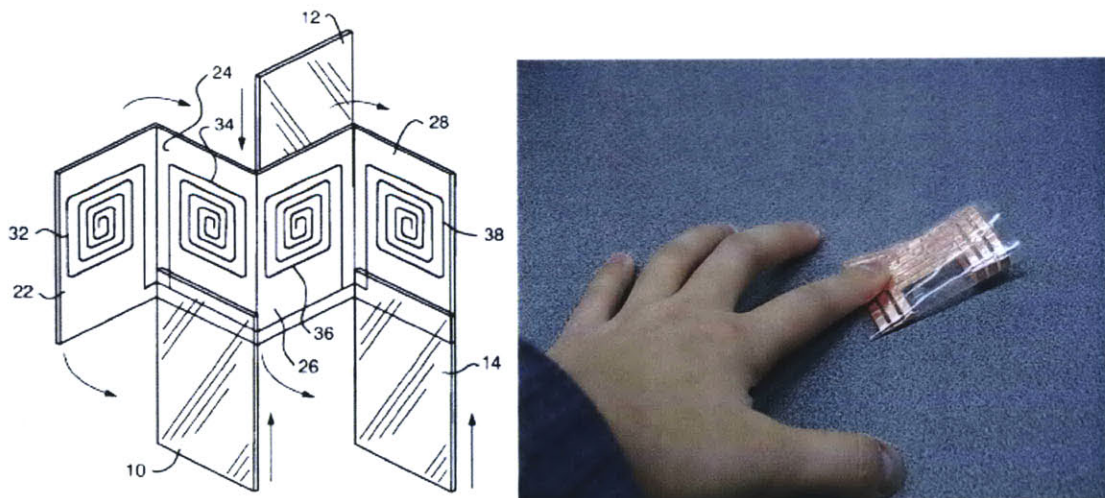

Figure 23. Diagram of folded resonant tags (left) and photo of dynamic folding (right)

One major source of inspiration for the Origami Desk project was fellow Media Lab student Richard Fletcher's PhD thesis work investigating the parameters governing the resonant frequencies of low-cost electromagnetic radio-frequency security tags. [12] Fletcher is characterizing how different geometries and folding patterns result in different frequencies. These tags are typically static; they are used at a single resonant frequency chosen at design time. However, we were inspired to investigate if this same technology could be used in an active manner to detect dynamic properties—in this case, paper folds.

Early in our design process, we also looked into using numerous other technologies to monitor the user's folding. For example, we bandied about the idea of clipping on small boards to power trace in the paper so that we might measure contact between conductive areas; we investigated the use of conductive ink coils on various medium as a way to form capacitive elements that might break when a trace was folded; we considered using measuring the varying signal strength of printed ink antennae a la Motorola's BiStatix readers; we even contemplated using vision recognition systems, and thought about how to design registration-mark that would help us distinguish otherwise visually identical paper patterns.

The selection of off-the-shelf EAS tags in conjunction with a swept frequency tag reader for the fold sensing technology was based on several factors: We wanted a technology that would monitor the user's folding invisibly, thus eliminating technologies that could not operate under the user's workspace, while obscured by active hands. We decided our fold recognition technology needed to be largely orientation independent and free of any external wires or visible electronics. Most importantly, based on the expected number of visitors (500 a day) and the short time frame for development (roughly three months) the fold sensing mechanism needed to be inexpensive, repeatable, accurate, and manufacturable. Of all the considered technologies, the EAS/swept tag combo seemed the most feasible, and preliminary tests with this design were promising. As can be seen in Figure 24, the resonant frequency and the quality of the resonance change when the paper is folded.

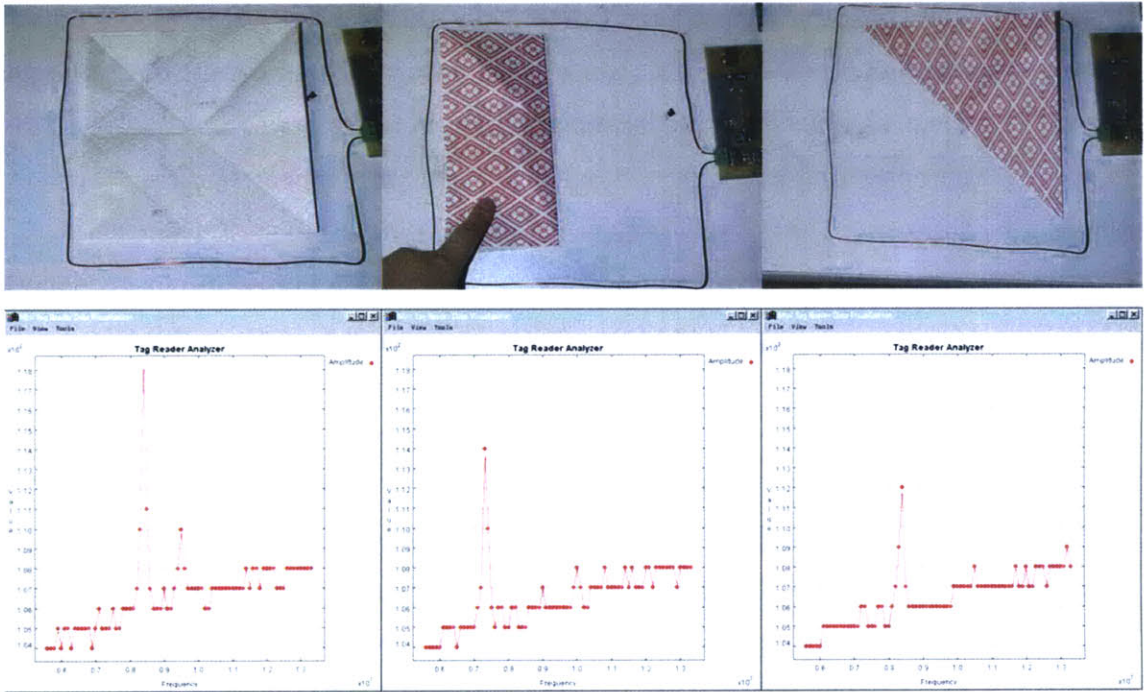

Figure 24. Data results from early proof-of-concept tests using EAS tags of different frequencies

We used tag reading hardware previously developed by Richard Fletcher and Olufemi Omojola for the UnPrivate House exhibit at MOMA. This hardware is capable of reading frequencies between 5 and 40 MHz, which was suited to the EAS tags. We initially planned to modify the capacitive patch on the 8.2 MHz tags to form tags of other frequencies, but later found that Miyake Corporation in Japan manufactured tags range from 7 to 26 MHz in frequency in more desirable sizes.

Origami Desk Tag Reader operating characteristics:	
Swept frequency range	6.5- 26.5 MHz
Swept frequency step size	200 kHz
Sweep rate	10 Hz
Baseline drift (lab environment, between recalibrations)	< 1%
Line width (receiver bandwidth limited)	~0.6 MHz

Figure 25. Origami Desk Tag Reader operating characteristics

The width of the frequency peaks determined the minimum spacing of the frequencies of the tags and the coupled frequencies of overlapping tags. The unfolded tags were very consistent in their frequency response, but the peaks from the overlapping tags would deviate approximately 1.0MHz depending on how accurately the labels were placed. The ratio between the frequency peaks and the environmental noise determines the number of sweeps that need to be average to reveal a recognizable pattern; this number has to be calibrated on site. This averaging causes the temporal resolution to go down; this could be a concern with more rapid gesture recognition, but most users take at least 3 seconds to finish a fold, which requires much less temporal resolution than the typical 10Hz speed of manual human tasks. Appendix E shows data results from each fold for the box pattern using the paper design described in the following section.

Paper design

We experimented with numerous possible origami creations before deciding that the Origami Desk exhibit would teach people to fold either boxes or cranes. The boxes' symmetry and simplicity made it easy to fold and also made it an ideal pattern for our tag-reading feedback idea. The crane was selected because it was harder and more traditional.

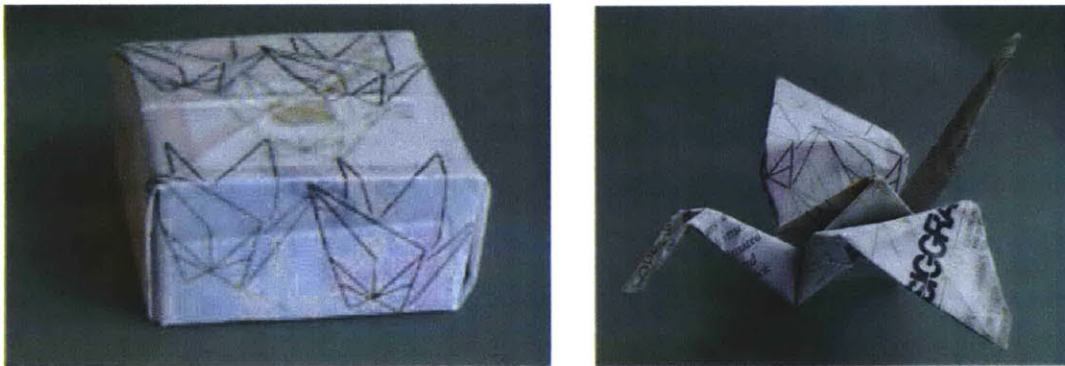

Figure 26. Origami Desk users choose between creating a box (left) or a crane (right)

Our origami paper's graphic design reflected these choices, using a motif of outline cranes on the square origami paper. The paper doubles as a flyer, with a brief description of the project, the names of the collaborators, and the logo for

SIGGRAPH on the corners. The layout of the copy is such that when the paper is folded into a box, the words disappear. The paper was printed on translucent paper to make the tag technology visible, to show people how the exhibit works.

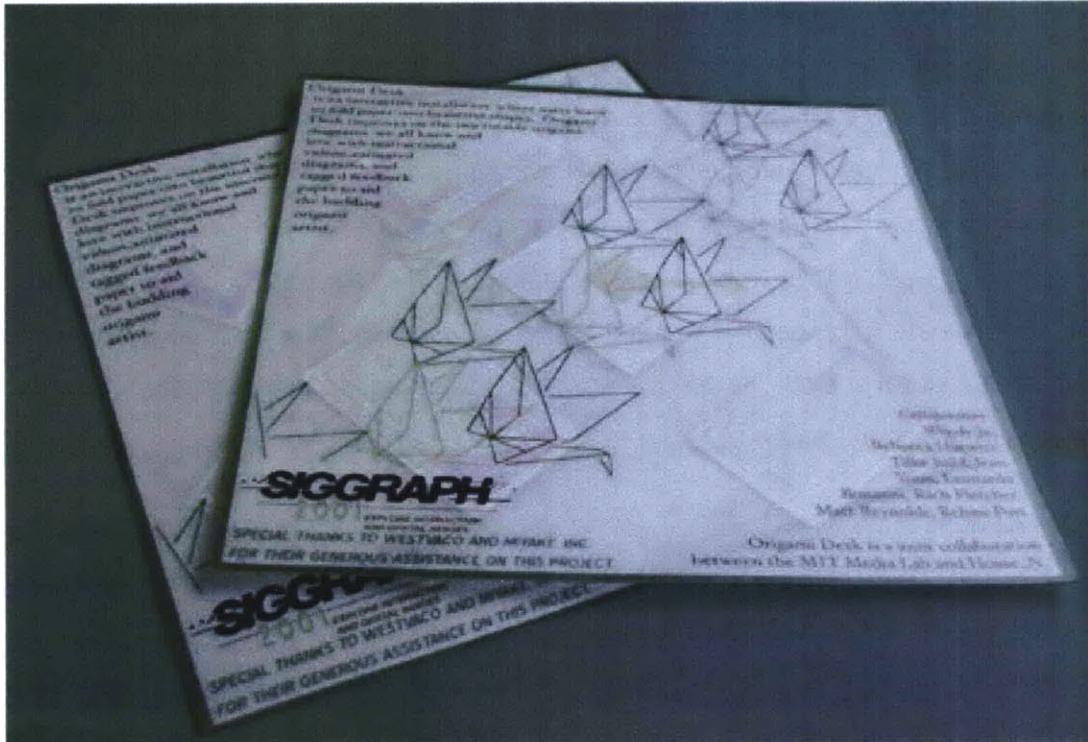

Figure 27. Origami Desk papers double as flyers. Note tags visible through the translucent paper.

Another aspect of the origami paper design was the layout of the tags in the paper. The fold sensing of the origami paper exploits two characteristics of radio-frequency security tags. If the tags are folded in half, no net current is induced in the electromagnetic coil of the tags, and hence they do not resonate. If one tag overlaps another, the two couple to yield a shared resonant frequency that is a function of the overlapped area between the two sets of tags. As one may suspect, the number and location of the origami tags differs with each origami design, for the sensors need to be laid out to correspond with the folds. Forced to custom-design our paper around one design, we decided to layout our origami paper tags for the simpler origami box.

Using two sizes of commercial radio-frequency security tags from Miyake Corporation, we experimented with a variety of designs, using symmetry and the tag coupling effect monitor as many folds as possible while reducing the overall number of

tags. We chose to use Miyake’s tags because they are available in a range of frequencies from 7 MHz to 25 MHz and are also robust enough to survive multiple folds. The unique frequencies allow the fold sensor to distinguish different paper folds, but also have to be laid out in such a manner so that overlapping tags form coupled frequencies distinct from the individual tag frequencies and other coupled frequencies. The tag layout design illustrated in Figure 9 and the software in described in the following section allow us to uniquely determine seven of the eleven folds used in the making of the origami box. The size of the tags relative to the paper prevented us from placing tags to monitor those remaining four folds. Data results from different folds using this origami paper tag layout are shown in Appendix E.

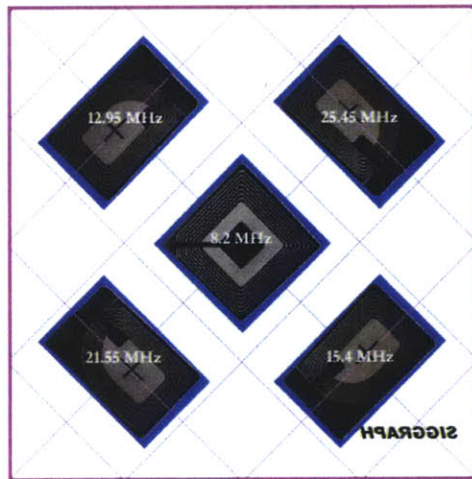

Figure 28. Template for origami paper tag layout. Pink lines indicate fold locations for box design.

Pattern recognition

To convert the raw sensor data from the tag reader into “paper states” that correspond to different folds, we modified the MOMA tag reading Java program written by Olufemi Omojola by adding two classes. The first class identifies peaks by comparing a five-sweep average to a baseline, and pulling out data points that exceed a certain percentage threshold. The program assigns peaks to fifteen different “buckets,” eight of which are used in the pattern recognition. The second class then matches the different bucket states to different paper folds, or paper states. This class includes hysteretic mechanism that requires the fold to be detected three times in a

row before the determined paper state is broadcast over the network via UDP; we found this to be adequate in keeping the fold sensor from registering intermediate states that occur briefly as the paper is in the processing of being folded.

Interface design

The structure of the Origami Desk site mimicked that of CounterActive's French Getaway; one main opening screen presents options to start folding a box, to start folding a crane, or to learn more about the exhibit. Each set of instructions began with a introductory page, which then gives way to instructional pages which all have mpeg videos of hands demonstrating each step and Macromedia Flash animations projected on the expected workspace indicating how and where the paper was to be folded. We used color and shapes to help indicate which areas of the interface were meant to be buttons, which were meant to be displays, and which were designated working areas.

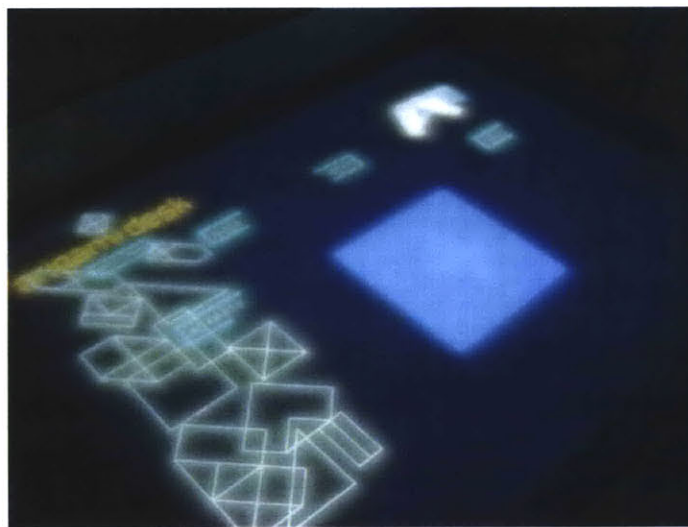

Figure 29. Photo of Origami Desk interface on actual worksurface.

All the instructional material on the pages of the crane and box tutorials were created by members of the Origami Desk team. We experimented with several visual styles and camera angles for the demonstration videos. For our prototype run for the May TTT sponsor meeting, we intercut shots angled from over the shoulder of the folder and zoomed-in detail shots for the more intricate folds. We used two pairs of gloves,

one long set that was black to match the black background and another short set that was white, to create the illusion of “Mickey mouse” hands floating in space.

The art direction of our final video clips further emphasized this sort of departure from reality; instead of shooting from the side, as if the viewer were watching another person fold, we used one straight overhead shot angled so that the user could more easily mimic the movement of the gloves. We used large origami paper to help make the hands in the video seem smaller, and to help prevent the hands from obscuring the movies. The hands execute very carefully choreographed movements, as opposed to the more realistic folding seen in *Origami: The Secret Life of Paper*. [4] We selected paper colors and background materials to heighten visual contrast; by matching the video background and the interface background exactly, the paper and hands of the video appear to float on the interface itself, and not in a movie box.

The animations of the origami paper were created in Macromedia Flash, and converted to Shockwave files that were subsequently embedded into the interface’s Dynamic HTML pages. The size of the animated origami paper was calibrated so that the projected image would be the same size as the user’s actual origami paper. This enabled us to make use of the overhead projection to indicate exactly where the user should fold the paper, and helps to integrate the digital and physical domains.

Structure design

One vital aspect of the Origami Desk project is the physical desk structure, which houses the projector, field-sensing array and tag reading hardware.

Our design goals for the structure are multi-fold:

- to integrate the display and sensing technologies into one structure
- to provide a peaceful and meditative environment for the user to work in
- to allow people to walk around back to see the technologies that make the interaction possible to catch the attention of passersby from a distance

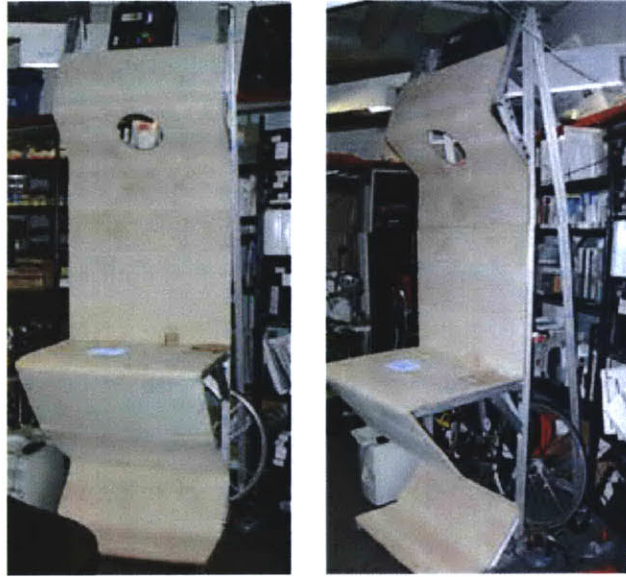

Figure 30. Prototype Origami Desk demonstrated at May 2001 TTT

The prototype of the Origami Desk structure was built around the metaphor of folding; the thin wood veneer surface of the workspace itself was supposed to invoke the concept of having been folded. However, we determined as a team that the metaphor was a bit awkward; team member Bonanni came back with a design that combined visual elements from a Japanese folding screen and the coiled pattern of the tags in the origami paper.

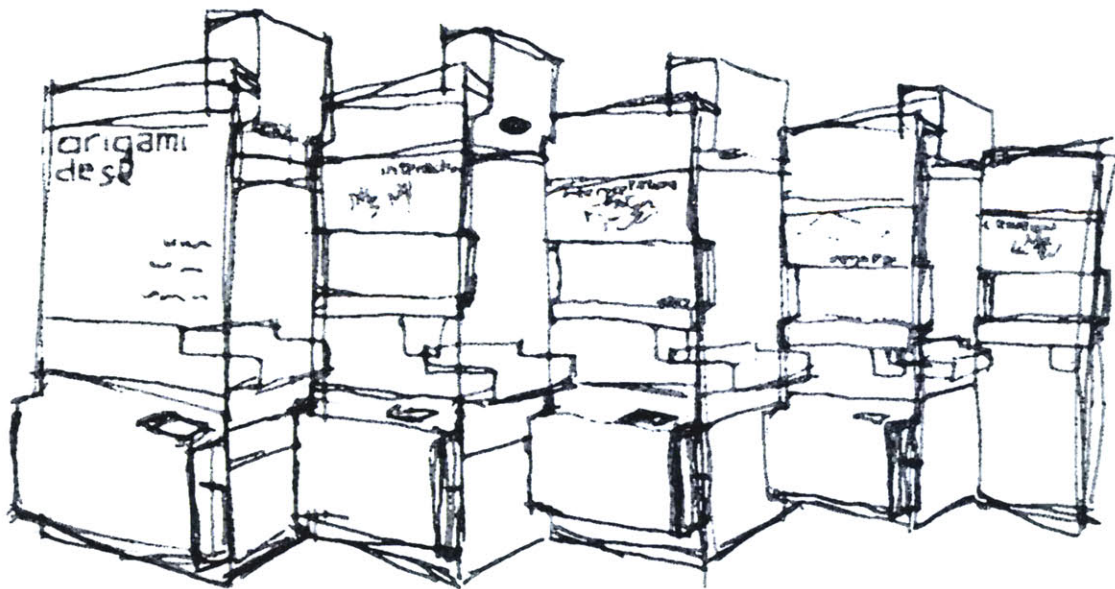

Figure 31. Sketch of Origami Desk installation design.

There are four stations in the Origami Desk installation; the folds of the screen provides users some private space to focus on their folding while uniting the four units into a coherent whole. The final design was executed in lightweight 80-20 frame pieces and bent panels of translucent white Plexiglas. Its open sections made it easier for others to look on as users folded, and allowed us to lean over the interface from behind to provide assistance as needed. A front panel was added to allow signage to let users know the name of the exhibit, and sepia-tone photos printed on transparent media were added to help the exhibit communicate its purpose to passersby.

System integration

Many of the challenges of the Origami Desk project lay in the integration of different system components. It was very necessary to consider how the different components interacted, to design affordances for one part of the system in the other. The origami paper, for example, starts in clear trays located within arms reach of each Origami Desk station. It migrates to the desk surface, where it interacts with the swept frequency tag reader to sense paper folds. Finally, it ends up in on the display shelf or in the clear trash receptacles of each Origami Desk.

The physical layout of the sensors and interface on the Origami Desk structure exemplifies the complexity of our system integration issues. Because users are interacting directly with the work surface they are looking at and folding on, we had to overlap the read coil of the tag reader with the active space of the tauFish array, and fit both boards and their accompanying network converters within the desk area, which in turn affected the visual layout of the interface. We had to verify that harmonics of the tauFish electric fields did not interfere with the swept-frequency tag reader, and had to filter out coupled noise on the network lines that was broadcast on the electrodes of the tauFish array. The tauFish was aligned to the left of the display area, making room for the tag reader hardware and Filaments on the left. This created a "no button zone" of about 3.5 inches on the right side of the screen; this left-ward bias on the interface might have seemed unnatural to the user if they were not forced to stand left-of-center of the workspace by the computer mounted by their legs on the right.

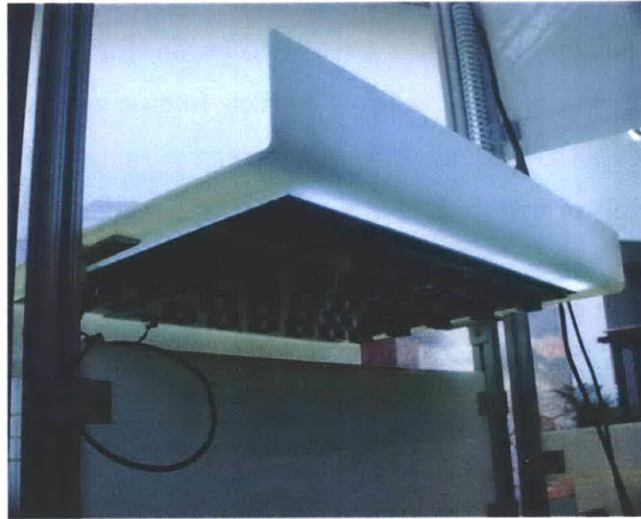

Figure 32. The translucent plastic aids in alignment of sensors under the Origami Desk surface.

Because the function of components of the Origami Desk system are so deeply intertwined, design decisions made in one part of the system often create challenges in another. The interaction designer must work hard not only to minimize such problems but also to exploit synergies between the components. We are often asked about our decision to use overhead projection as opposed to rear projection. The operation of tauFish array and tag reader requires that they be mounted directly under the work plane; this rules out the use of rear-projection technology. The 1.5-inch vertical read range of the tauFish array also limits (though it does not preclude) the use of flat-screen display technologies on the desk surface. The use of overhead projection affects the interface layout, for display elements need to be located above the work area to prevent occlusion problems. However, the overhead projection allows us to project lines and animated folds onto the paper directly –an important feature. People also inquire about our choice of translucent Plexiglas for a display substrate. We chose this material because it caused a “glowing” effect on the interface, but it dictated that we use display elements of a certain size to allow readability, and that we use a black background on the interface to prevent colors from bleeding onto one another. The translucent medium also had the beneficial side effect of making alignment of the sensor arrays under the worksurface easier, and allowed the interface designers to more easily match the displayed elements to physical landmarks like the tag reader coil.

Evaluation



Figure 33. Origami Desk draws crowds at SIGGRAPH 2001 in Los Angeles

Origami Desk was received with great enthusiasm at SIGGRAPH 2001. There were usually crowds around the exhibit of people waiting in line or watching others fold. We were gratified to find that roughly 90% of the users completed the box or crane programs in their entirety, which indicated both that the system was functional enough to guide someone through the whole process and that it was interesting enough to keep users engaged to the finish. We typically had three of the Origami Desk stations running the Origami Desk interface, and left one station devoted to displaying the raw data of the sensors beneath the system; some visitors were deeply interested in seeing how the desks really worked, but many indicated impatience at having to wait to use the other stations, and begged us to convert the data station back to another folding station. Many self-proclaimed origami enthusiasts approached us and stated that although they already know how to fold the crane or box, they enjoyed the experience of folding with Origami Desk nevertheless.

At the time of the SIGGRAPH exhibit, the fold sensing was not functioning due to lack of time available to calibrate the fold-sensing program to the exhibit's noise environment and to program appropriate response in the interface to the different paper states. This was unfortunate, because it caused some justifiable confusion over the need for the coils in the paper and some unwarranted skepticism over the feasibility of using the coils as fold sensors. However, many critics were placated by demonstrations of the live sensor data, because they could clearly see how the peak patterns changed with the different folds.

The tauFish sensor arrays were functional, and most users were able to use them to navigate their ways through the origami instructions. Their operation was not bug-free, however. The real-life testing of the exhibit environment revealed several shortcomings of the tauFish's modeling mechanisms. First of all, the tauFish's normalization algorithm implicitly assumes one-handed interaction; the people using the Origami Desk usually had both hands on the interface, causing the "hits" to be more difficult to register. Also, some patrons had tummies that would rest up on the edge of the desk, or would lean their elbows on the surface while they were watching the movies, which also affected the normalization of the capacitance readings. We also had issues with hysteresis in registering the hotspot hits. Occasionally the interface would register two hits and progress ahead two pages instead of one; the resulting confusion lead us to modify the instructions halfway through the conference so that each page had page numbers that let users monitor which step they were on.

We estimate that it took users about four minutes on average to finish the box program, and eight minutes to finish the crane program. The crane program was definitely the more popular option for Origami Desk patrons, despite our repeated warnings it was a more difficult design in general and harder in this specific instance because the tags in the origami paper were designed for the box pattern. Users were usually thrilled to finish the program, and usually commented both on the difficulty of the task ("That was actually pretty hard!") and their pride on having created something "all by myself." Comments of the second variety indicated to us that the

Origami Desk succeeded in its goal of preserving the agency of the users, and reaffirmed the Papertian idea that the challenge of creation improves people's self-esteem.

User testing

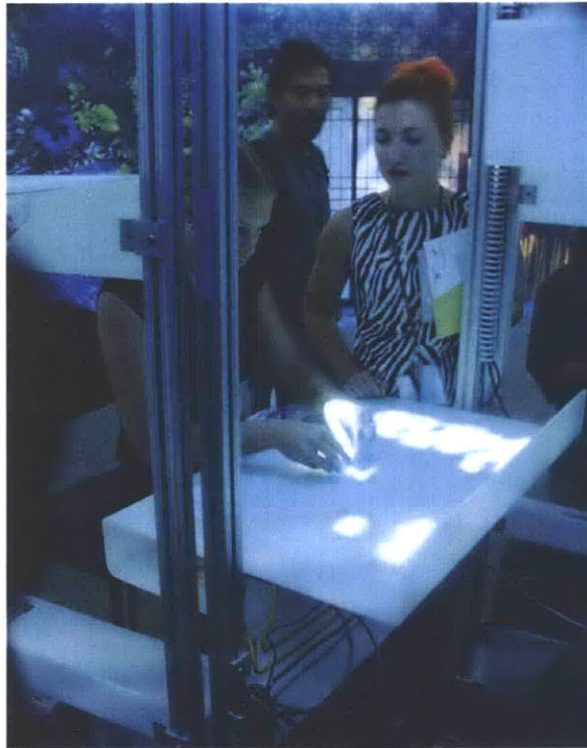

Figure 34. Participants at SIGGRAPH provided empirical user tests results

At the time of this thesis' submission, we have not conducted any formal user testing of the Origami Desk to supplement our empirical results. However, it is our intent to conduct a set of tests to compare the Origami Desk and more traditional origami diagrams. The leading questions that we were interested in are:

- How long does it take for a person to complete an origami box/crane with and without the table?
- Does the user express joy, frustration, or discouragement when doing origami when working with and without the table, and how often?
- What percentage of users actually complete a box/crane when working with and without the table?
- What are the user's general reactions to both environments?

- At what specific points is outside help needed?

These tests are modeled in part on the tests by Georgia Tech's Origami EPSS [29] mentioned previously in the prior work section of this chapter.

Future Implications

Despite some technical problems with the operation of the sensors, we feel that Origami Desk succeeded in both enticing people to learn origami and in communicating the possibilities offered by Active Workspaces. Recommended follow-up tasks included automating the calibration procedure for the tag-reading interface, both to help the sensor adjust to new environments and to make it easier to create other tag template layouts for designs other than the origami box. Also, further investigations of the effects of different interface mechanisms would be useful for long-term development of other interactive learning programs.

We received many invitations to exhibit Origami Desk in other venues, mostly children's museums and conferences. Inquirers usually cited the fun of creating something real, the interactivity and the learning about underlying technologies as key reasons why Origami Desk and other such exhibits would succeed in such environments. Though future engagements are still pending, we are heartened by these solicitations, and feel that this indicates an immediate future for Active Workspaces in the public exhibit arena.

CHAPTER 5. CONCLUSION

“One cannot understand a technology without having a functional understanding of how it is used. Furthermore, that understanding must incorporate a holistic view of the network of technologies and activities into which it fits, rather than treating the technological devices in isolation.”

--Terry Winograd and Fernando Flores,
Understanding Computers and Cognition

Although CounterActive and Origami Desk have scarcely scratched the surface of what Active Workspaces will be able to do, it is nevertheless clear that they are the beginnings of something much larger. These early projects suggest design principles for Active Workspaces and shed light on a few crucial enabling technologies. In this section, I review these design principles and technologies and conclude by speculating on possibilities for future work in this domain.

Design Principles for Active Workspaces

The philosophical underpinnings of Active Workspaces are simple and few, but regard for these principles will greatly reduce the iterations needed to reach a successful design, and will enhance the overall user experience. These bear some similarity to the principles suggested by Cooperstock *et al.* in their design of Responsive Environments, [7] but also go beyond these to incorporate principles that govern learning and system integration issues.

- **Enable User Control:** For Active Workspaces to truly be a tool, the user needs to be able to set the pace, direction and tone. Be sure to pick the right tool for the task.

- **Incorporate Adaptability:** Because workspaces are often shared by different people with different skills in different situations, adaptability is required to optimally address the myriad demands placed on the environment.
- **Provide Feedback:** Instantaneous feedback helps users receive acknowledgement of their actions; higher-level feedback is also essential for users to gauge their performance and correct their technique or process. Also, do not limit yourself to visual or auditory cues by default; consider what sensory channel is appropriate for the situation at hand.
- **Exercise Appropriate Degrees of Translucency:** The contradictory needs for “invisible” tools that allow users to focus on the task and “visible” tools that clearly communicate how they work challenges the designer to discover ways to achieve both ends, to locate the proper degree of “translucency” for the situation.
- **Strive for Coherency:** Seamlessness is difficult to obtain in large heterogeneous systems, but is still a worthy goal. Tight coordination of disparate parts into a cohesive scenario is one avenue to a coherent design; another is smooth coordination over an entire process.

Process guidelines

The building of Active Workspaces reveals as much about the process of design as it does about the potential of this emerging field of applications. The task of determining the proper balance between different elements of Active Workspaces is tricky, full of false starts and missteps. Here are a few process guidelines that underlie the designs of this thesis:

- 1) **Start designing now.** Design cannot be toweled onto the surface of the workspace. It must be included from the moment of conception and must be subject to considerable scrutiny upon completion.
- 2) **Start with people.** The needs, wants and behaviors of people provide a wonderful point from which to leap into the design space. Be sure consider people’s movement in space and their interaction with other objects.

- 3) **Know the technology and materials.** Understanding the capabilities and limitations of the tools employed allows the designer to use them in innovative ways and to push their development in new directions.
- 4) **Use every tool in the arsenal.** The designs in this thesis utilize a wide array of media, from architecture, photography, and graphic art to web pages, digital video, and code. It is vital that the design of Active Workspaces be driven by the needs of the applications, not the limitations of the designers' expertise.
- 5) **Be critical always.** The active design process requires the designer to be curious, analytical and opinionated, but also to test out ideas and assumptions.

New directions

New possible applications for Active Workspace design abound. It is easy to see how the interactive kitchen counter and origami desk might evolve quite naturally into a smart lab bench, an intelligent manufacturing station, or a multimedia physical therapy station. It is my belief that the specific application is less important than the development of a design methodology for Active Workspaces, and objective rubrics for measuring the efficacy of such systems.

Active Workspaces are poised to exploit advances in a number of technological fields. Smaller computers, lighter networks, new substrate materials that enable printed circuits or inexpensive display media and the ever growing realm of new sensors will find a happy home in Active Workspace design. These widening variety of computing and sensing materials give the Active Workspace designer's greater reign in finding creative solutions that fit a specific task or set of tools, just as the tauFish array fit under the kitchen counter, or the Electronic Article Surveillance tags fit on the origami paper. Follow-on applications should further investigations into using augmented materials and tools to monitor people for performance feedback, but should also investigate situations where the computers ability to store data and gauge long-term progress are employed.

What is still missing on the technology horizon are tools that help Active Workspaces identify states of people, objects and tasks based on data from sensors distributed

throughout the workspace environment. The need for these technologies come straight out of the design principles; the opportunities for control, adaptability, feedback variable translucency, and even coherency are greater when the system has the ability to infer what events are going on in the user's world and develop an appropriate response. This sort of inference, goal-driven planning and event modeling work has until now been largely the purview of artificial intelligence research, and recently of intelligent user interface designs for software applications. Very little work has been done in this arena in the environmental design domain. The next step forward for Active Workspaces, then, regardless of application, is to investigate the work space as an intelligent embedded system. In this way, the same technologies that allow computers to act as our embodied servants may also be used to help us use our own bodies to serve ourselves.

APPENDIX A. COUNTERACTIVE SCREENSHOTS



Screenshot from Sour Cream Berry Tarts

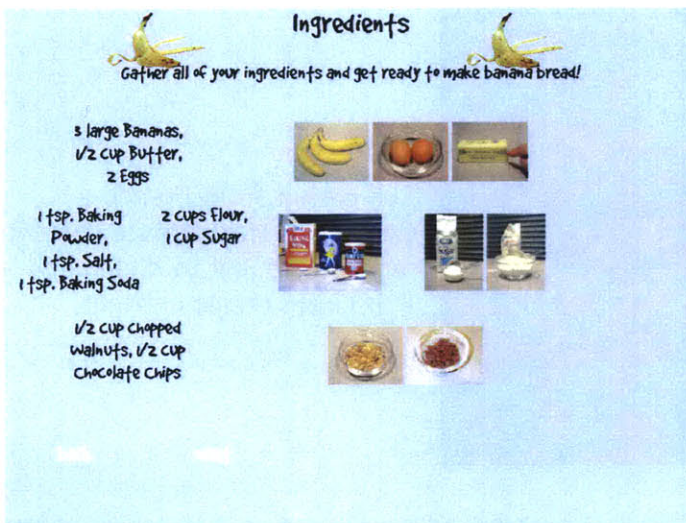

Screenshot from ingredients page of Banana Bread



"If your avocados are hard, they're not ripe!"
Still from Guacamole movie in South of the Border,
Featuring graduate student Matthew Debski



Screenshot from introductory menu for French Getaway

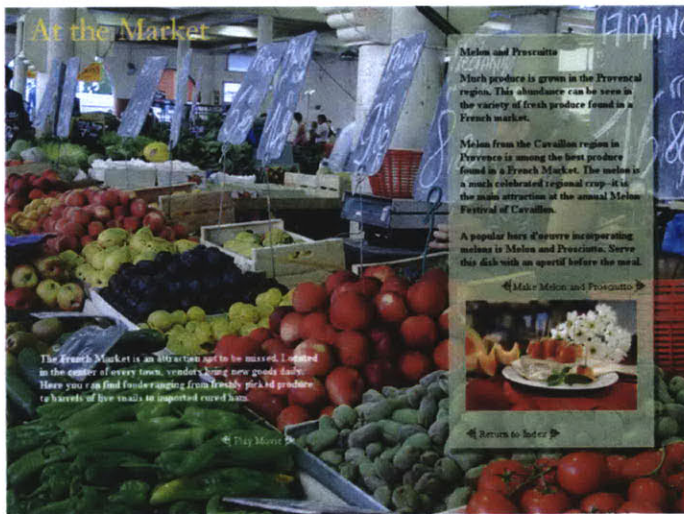

Screenshot from French Getaway-- Marketplace content page. Note link to Melon and Prosciutto recipe on right.

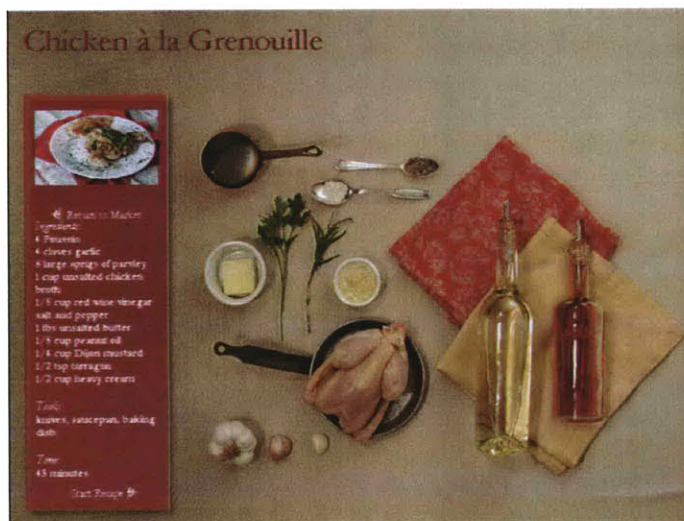

Screenshot for intro screen for French Getaway recipe Chicken à la Grenouille

A P P E N D I X B . U S E R T E S T P R O C E D U R E

The following is excerpted from our Application for Approval to Use Humans as Experimental Subjects, dated November 4th 2000.

Purpose of Study:

The progress of computer technology into everyday consumer appliances makes possible new applications that interact with people in their very own homes, helping them complete everyday tasks and learn new skills. The home kitchen is one key environment for these new applications, for it is a space where people are actively engaging in goal oriented tasks, such as cooking, cleaning, or planning—tasks that may demand help or encouragement to complete. The CounterActive kitchen counter is designed to help users in the task of cooking a recipe. Using a computer, a projector and a variety of hidden sensors, the kitchen counter is able to interactively teach people to cook; it's rich multimedia capabilities also enable the counter to provide entertainment or to set the atmosphere in order to keep the user engaged in their task.

This study will seek to determine the aptness and usability of an interactive kitchen counter that guides users through recipes. It is possible for the counter to adapt to the needs of different kinds of users—people of varying cooking experience, people of different ages, people with varying computer experience. Thus, it is important to verify what needs users may have in the kitchen environment, test the ability of the counter's user interface to provide users with relevant information, gauge user reactions toward the style of the counter's interface and the entertainment value of its content and determine the impact this interface may have on people's desire and ability to cook.

There are several benefits to this study. One is to gain empirical information regarding the use of interactive technologies in helping people finish a given task. This is of interest to numerous fields, as the ability to train people on demand can be of use in manufacturing environments, in laboratory environments, and in fact, in any place with a workbench setting. Additionally, this project is designed to provide information about user interface design principles for next-generation computer devices that have far reaching implications for interaction design professionals, educators and many other disciplines.

PART II:

EXPERIMENTAL PROTOCOL:

In the experiment, subjects will be asked to prepare one of a few recipes using the kitchen counter. (Please see included sample screenshots.) The counter will provide both video and audio instructions on how to make some prepared dish as the subject touches various words or icons projected on the kitchen counter. During the experiment, the subjects actions may be monitored via electric field sensors and radio-frequency identification (RFID) tag sensors. The field sensing is used in conjunction with the projected visual interface to behave like a touch screen which allows the subjects to move from step to step of the recipe. The RFID tag sensors will monitor the movement of ingredients and kitchen tools as they are being used. The subject will be asked to vocalize their on-going questions, thoughts and reactions throughout the cooking process; at least one experimenter will be on hand to record notes on the subjects' actions and thoughts, to monitor the subjects to ensure that their safety and to provide them with any information necessary to complete the task. The subjects will be told to expect a short series of questions afterward.

Before the experiment, subjects will be asked questions to determine demographic information, their previous computer experience and their previous cooking experience. They will also be asked about what sort of help they think would be useful during the cooking process. After the experiment, subjects will be asked to verbally describe their feelings toward the task, the interface and the end-product of their cooking. The experimenter will take written notes based on the subjects' responses.

The recipes each subject is asked to prepare will be geared for their skill and age level; subjects below the age of 13 will be assisted by the experimenters, who will perform any steps involving the use of sharp objects, electric equipment or kitchen appliances. Subjects of various ages are necessary to determine how the user interface must be adapted to users of various skill levels, include those who may have difficulty reading or who may have little knowledge of kitchen tools and their usage.

All sensors involve with the counter interface are completely non-invasive and require little or no preparation for use. Employment of this equipment presents no threat of either physical or psychological discomfort to subjects.

Sample Interview Outline

I. Before cooking:

Background information on the user

- How old are you?

Background information on subject's cooking habits:

- How much cooking have you done before today?
- How did you learn what you know about cooking?
- How often do you cook?
- What sorts of things do you like to cook?
- Do you like cooking? Why/why not?
- Are there things you wish you had help with when you are cooking?

Background information on subject's computer experience:

- How much experience do you have with computers?
- What do you use computers for?
- How did you learn to use computers?
- Do you like using computers? Why/why not?
- Are there things about using computers you wish you had help with?

II. During cooking:

- What are you looking at?
- What are you thinking about?
- Is there anything that's puzzling you right now?
- What do you like/don't you like about (some aspect of the interface)?
- What does (instruction on interface) mean to you?
- Are the instructions clear to you? Do you know what to do?

III. After cooking:

- Tell me what you can remember about the steps you took to make _____.
- What about the kitchen counter did you like?
- What about the kitchen counter didn't you like?
- How is cooking with the counter like or unlike the way you're used to cooking?
- Are there things you wish the counter did that it did not do?
- Did you feel the instructions provided by the counter added or detracted from the experience?
- Did you feel the entertainment added or detracted from the experience?
- Were there aspects of the kitchen counter that were confusing? What would you do to change that?
- Did you like cooking with the counter more, the same or less than cooking without its instructions?
- Is there anything else you'd like to tell us about this experience?

APPENDIX C. USER TEST RESULTS

The testing of the children vividly illustrated both the strengths and shortcomings in the interface design. Both kids prepared food in the spot-lit areas and left the colored-blocked interaction areas clear without being told to. Both relied heavily on the videos to demonstrate actions, and played each multiple times; they also pointedly requested more videos in the post-interview. Pictures were taken very literally; because the eggs were shown in a small dish, the child first place the whole egg into a small bowl only to crack them into the larger bowl moments later. If we put multiple steps on a page, or multiple actions in one instruction, the children would sometimes inadvertently move on to the next step before finishing a task. Also, the kids were often unsure whether they had finished a task and would often hesitate until encouraged to proceed. Finally, when one child could not see instructional pictures because the large mixing bowl obstructed her view, we were reminded that different users require different counter designs. Both children claimed to like the kitchen counter, but had difficulty contrasting it to cooking in a normal kitchen or interacting with a normal computer, perhaps out of lack of enough experience with either. Both pointed out difficulties with the operation of the touch-sensing array; they did not understand how it worked, but felt it should respond more consistently to their touch.

The adults were surprisingly not so different from the children. All, regardless of cooking experience, expressed some insecurity about knowing how to do things the right way. Two of the college-aged users did not know the proper way to select and use a knife, but all four of the students continually asked testers whether they were doing things right along the way. They were more capable of keeping track of which steps they had completed than the children, but a couple still accidentally skipped steps. The adults gravitated more naturally toward following the visual cues designed to choreograph movement than did the children, indicating a possible need to adapt layout with scale.

All the users professed to enjoy cooking on the counter. One fellow was very surprised, and admitted to being skeptical about the success of the horizontal projection and the

use of the touch sensor, but said he was sold after using it. They universally found it helpful that the steps were read aloud and accompanied by video, but they faulted us for not making these redundant, “so that I can look if I’m not listening, or go to the fridge if I am.” The adult users also commented that they were glad that they controlled the pace of the cooking themselves. We did observe that the arrangement of information and granularity of detail needed to be adapted to account for different skill levels as well as previous experience with the recipe. The adults also expressed frustration at the tauFish’s seemingly variable sensitivity, although they all developed techniques for touching the counter (rubbing, putting both hands down, holding for a couple seconds) to make the sensor respond, and often supposed that it would be better, “once you got used to it.”

More importantly, however, we observed that the users were very taken with the videos demonstrating the steps; in fact, they would play them even after they had completed a step! Further questioning indicated that the users liked to watch the videos even if they knew how to perform a step or if they had already finished it-- because they liked the reassurance that they had performed the step correctly. “I look at it, and I feel good because I did it right,” said the female student. This indicated to us a larger need for user feedback in such an environment.

APPENDIX D. ORIGAMI DESK SCREENSHOTS

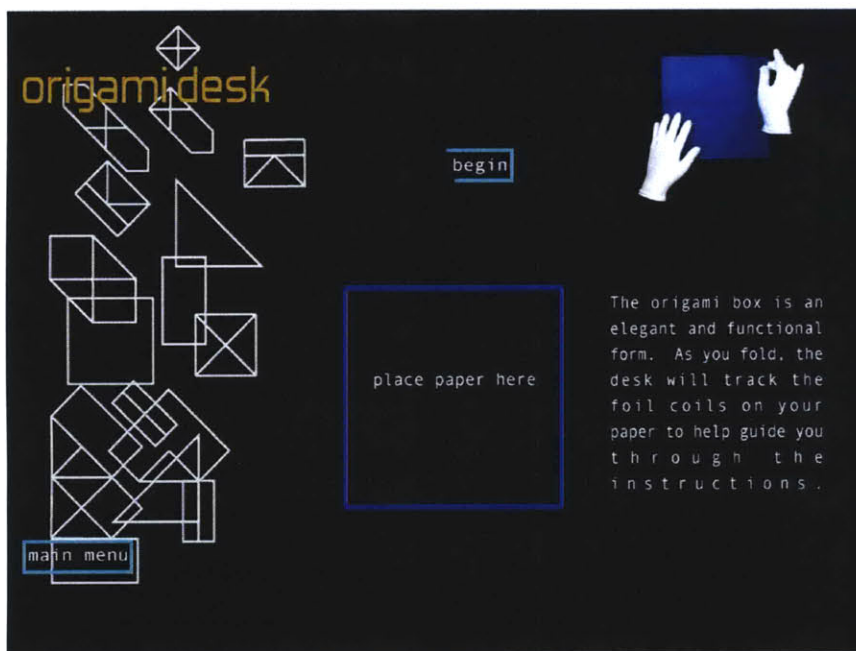

Screenshot from introductory page for origami box

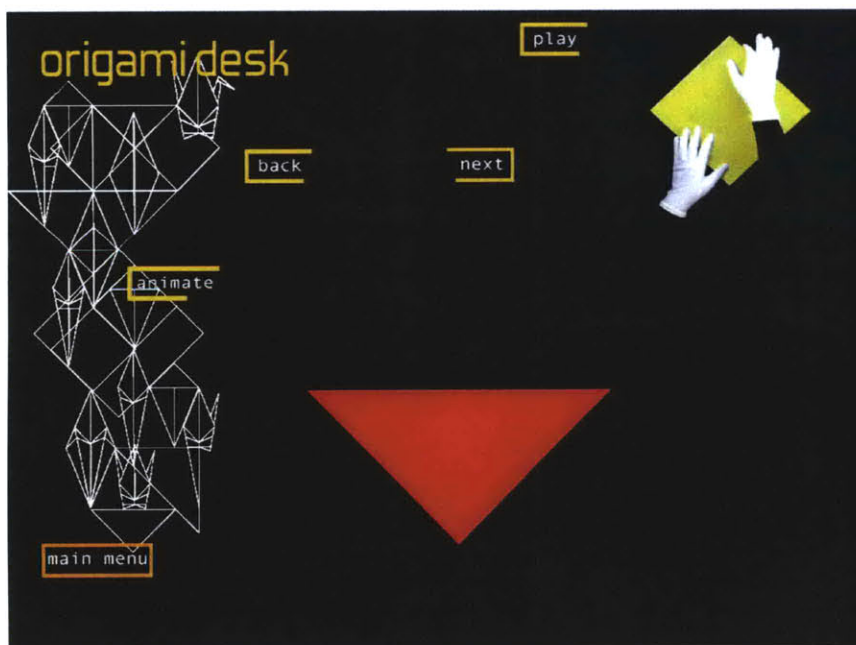

Screenshot from first instructional page for origami crane

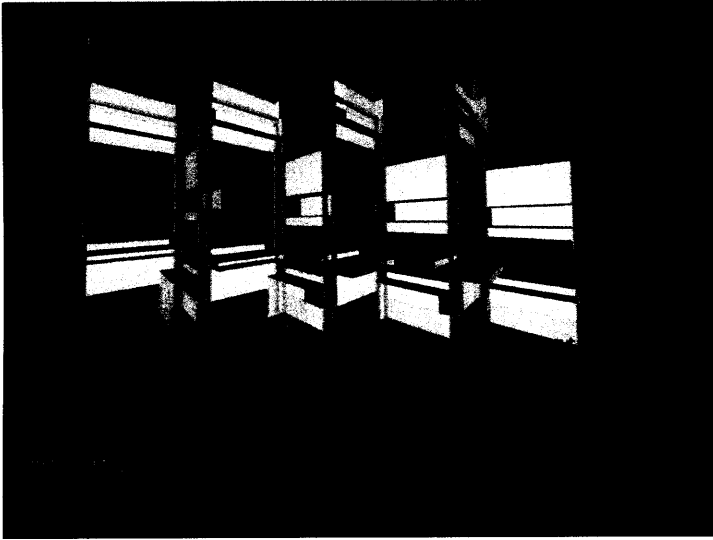

Screenshot from "About the installation" page



Screenshot from "About the tagreader" page

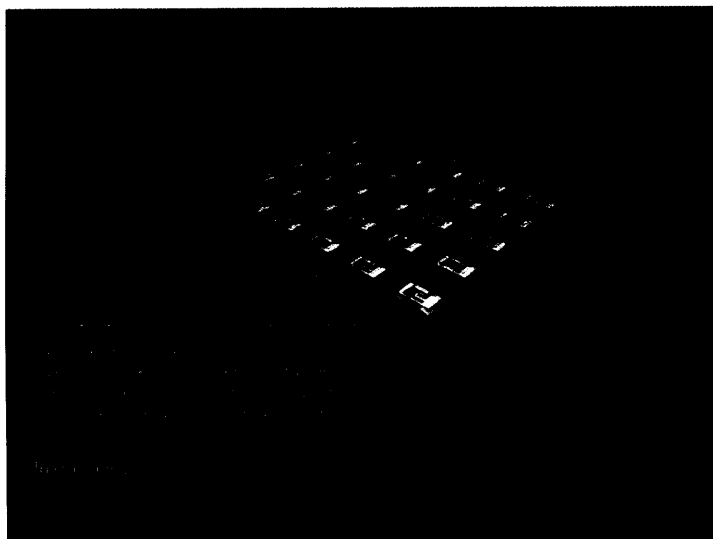

Screenshot from "About the tauFish array" page

APPENDIX E. ORIGAMI PAPER STATE DATA

This appendix shows the data from tests of the "active" origami paper. The fold tested is indicated on the left, the corresponding characteristic frequency response is on the right. The orange dot marks the 25.45MHz corner of the paper. Each graph shows data from one sheet over a 5-10 second period. The X axis is frequency (from ~5-26MHz) and the Y axis is normalized delta voltage response. Each graphed point is a running 5-point average (that is, the average of five sweeps through that frequency point) with the baseline subtracted out.

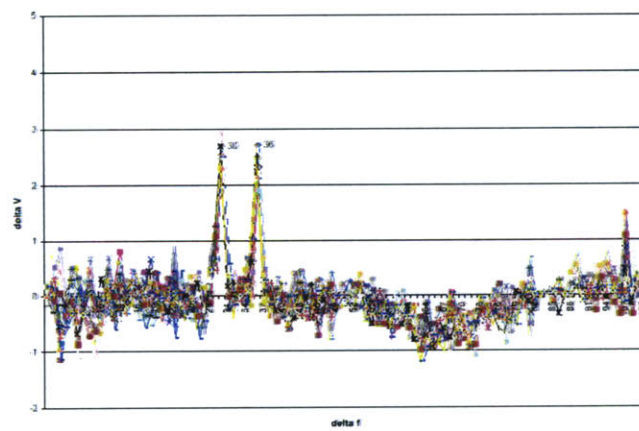
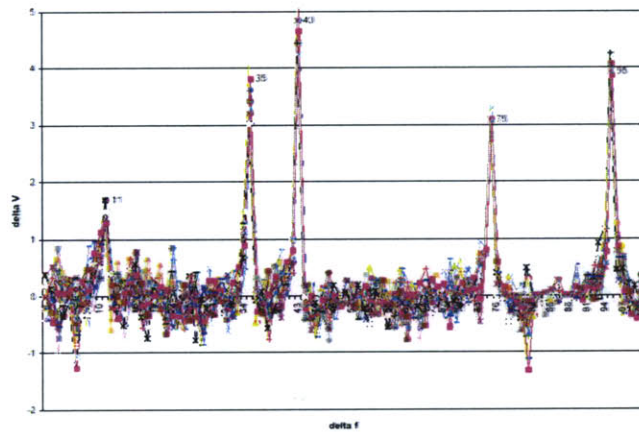
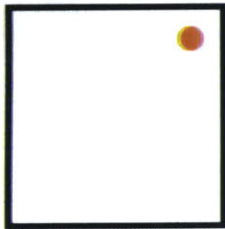

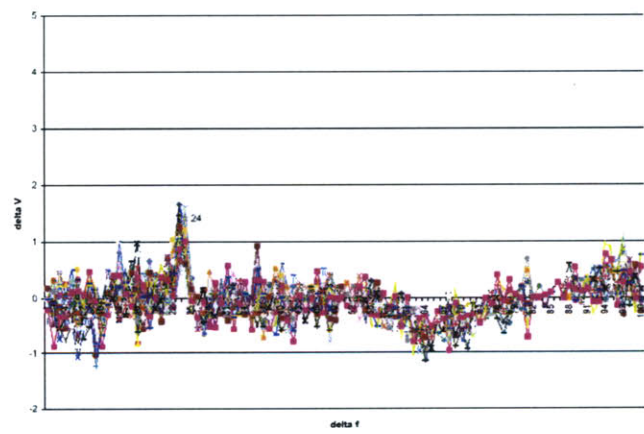
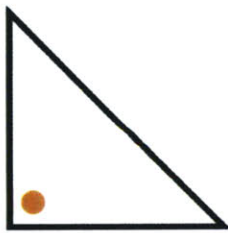
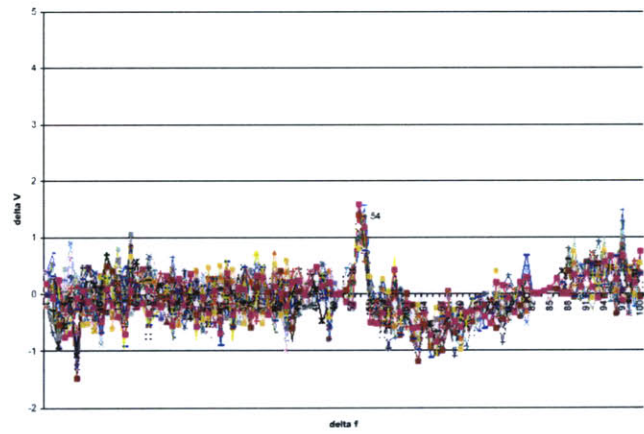
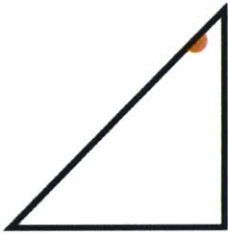
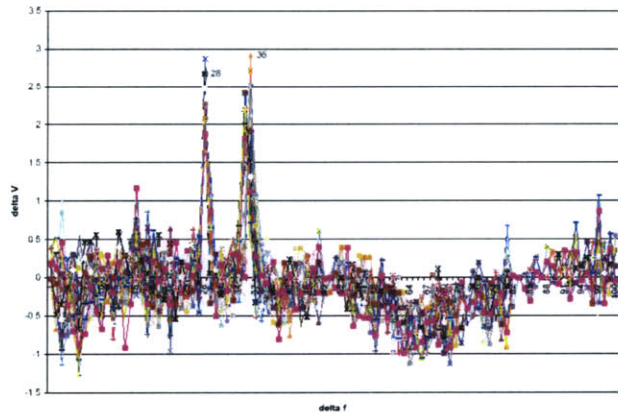

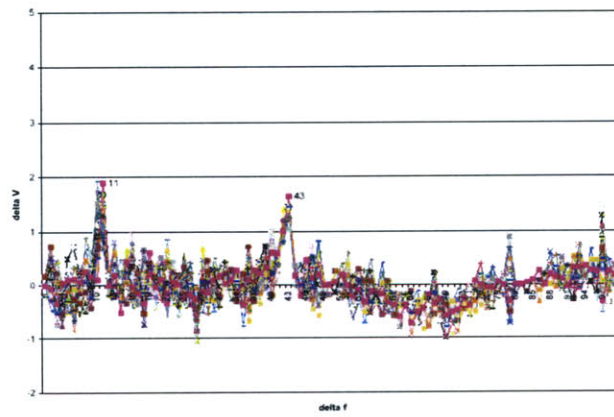
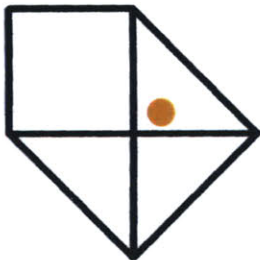
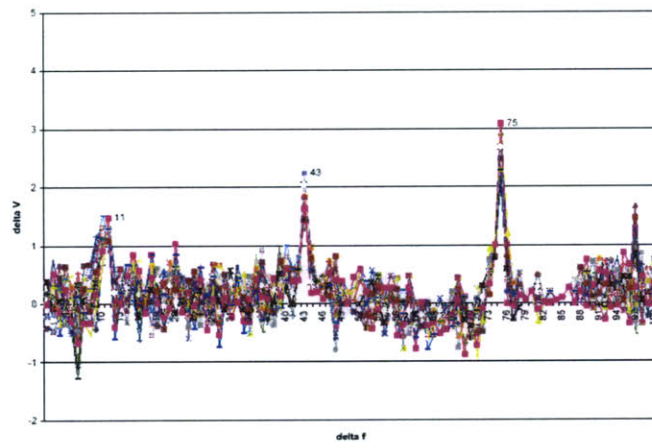
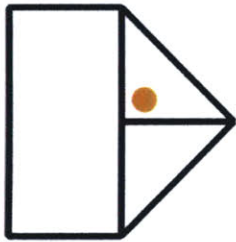
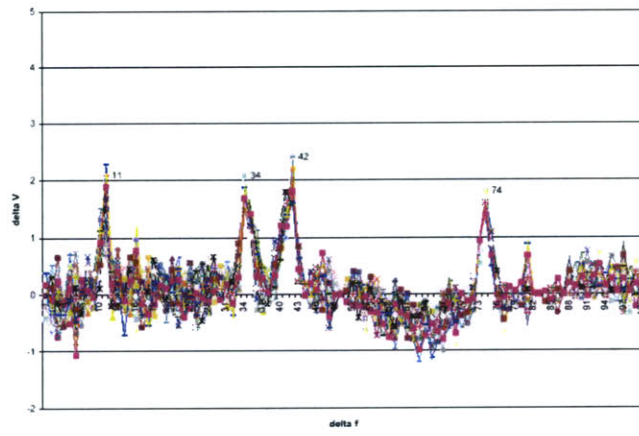
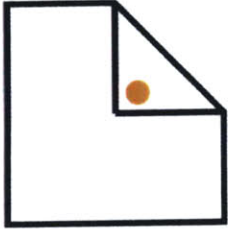

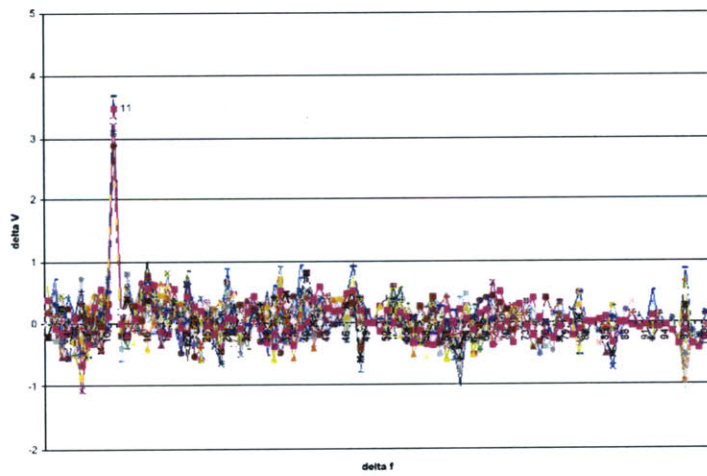
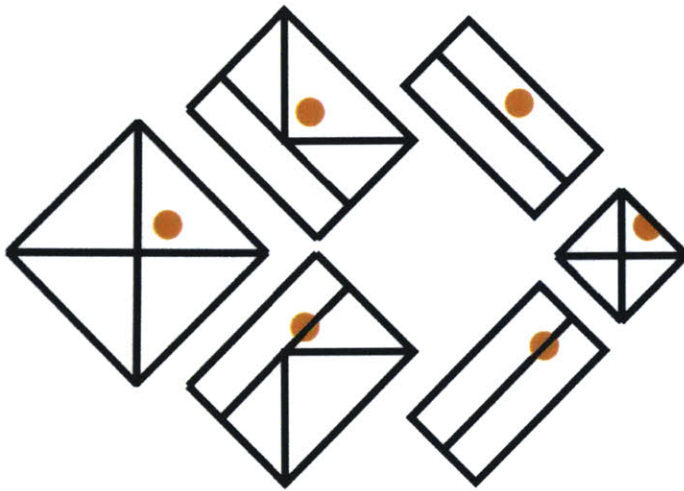
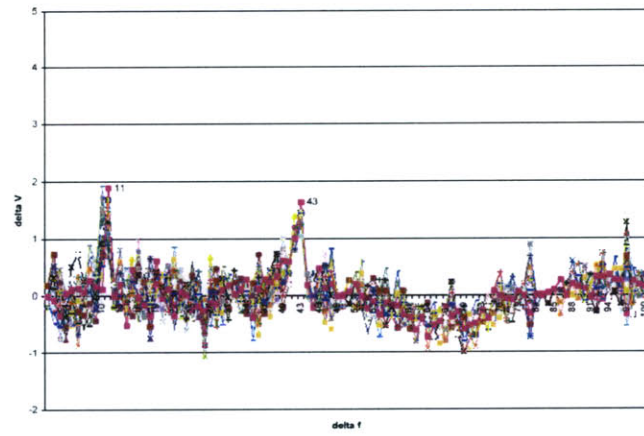
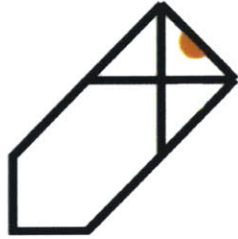

BIBLIOGRAPHY

1. Barry, D. "In a battle of wits with kitchen appliances, I'm toast," *Miami Herald*. 2/27/2000
2. Brumitt, B., B. Meyers, J. Krumm, A. Kern, and S. Shafer. *Easyliving: Technologies for intelligent environments* in Handheld and Ubiquitous Computing 2000 (HUC2K) 2000 (Bristol, UK), Springer Verlag, 12-29.
3. Bush, V. "As We May Think," *The Atlantic Monthly*. July 1945, 176(1):101-108
4. *Origami - The Secret Life of Paper*. CD-ROM. Salinas:Casady & Greene. 1996.
5. Coen, M.H. *The future of human-computer interaction, or how I learned to stop worrying and love my intelligent room*. IEEE Intelligent Systems, 14 (2): 8-10, March/April 1999
6. Colker, D. "Tomorrow's Kitchen, Yesterday's Recipe; MIT designers serve up futuristic ideas inspired by the past. Some are handy, others half-baked," *The Los Angeles Times*. Oct 19, 2000 T.1
7. Cooperstock, J.R., S. Fels, W. Buxton, K. Smith. *Reactive Environments*. Communications of the ACM, 40 (9): 65-73
8. Eisenberg, M., A. Nishioka, and M. Schreiner. *Helping Users Think in Three Dimensions: Steps Toward Incorporating Spatial Cognition in User Modelling* in 1997 International Conference on Intelligent User Interfaces 1997 (Orlando, Florida).
9. Elrod, S., G.Hall, R. Costanza, M. Dixon, J. des Rivieres. *Responsive office environments*. Communications of the ACM, Special Issue, Computer-Augmented Environments, 36 (7): 84-85, July 1993
10. Fitzmaurice, W.G., H. Ishii and W. Buxton. *Bricks: Laying the Foundations for Graspable User Interfaces* in SIGCHI '95 1995 (Denver, CO), ACM Press, 442-449.
11. Fox, A., B. Johanson, P. Hanrahan, and T. Winograd. *Integrating Information Appliances into an Interactive Space*. IEEE Computer Graphics and Applications, 20 (3): 54-65, May/June 2000
12. Gershenfeld, N., R. Fletcher. US Patent No. 6025725A: *Electrically Active Resonant Structures for Wireless Monitoring and Control*. MIT Media Lab, 2000.
13. Gray, M. *Infrastructure for an Intelligent Kitchen*, Master's, MIT: Cambridge, MA, 1999
14. Hammond, K. *Case-Based Planning: A Framework for Planning from Experience*. The Journal of Cognitive Science, 14 (4): 385-443, September 1990
15. Hindus, D., S. D. Mainwaring, A.E. Hagstrom, N. Leduc and O. Bayley. *Casablanca: Designing Social Communication Devices for the Home* in SIGCHI 2001 (Seattle, WA), ACM Press, 325-332.
16. Hoffman, E. "CounterActive," *FRAMES*. February 2000

17. Horvitz, E., J. Breese, D. Heckerman, D. Hovel, and K. Rommelse. *The Lumiere Project: Bayesian User Modeling for Inferring the Goals and Needs of Software Users*. in Proceedings of the Fourteenth Conference on Uncertainty in Artificial Intelligence 1998 (Madison, WI), Morgan Kaufmann: San Francisco, 256-265.
18. Ju, W., L. Bonanni, R. Fletcher, R. Hurwitz, T. Judd, J. Yoon, E. R. Post, M. Reynolds. *Origami Desk* in SIGGRAPH 2001 Conference Abstracts and Applications (Los Angeles, CA), ACM SIGGRAPH, 280.
19. Ju, W., R. Hurwitz, T. Judd, B. Lee. *CounterActive: An Interactive Cookbook for the Kitchen Counter* in SIGCHI 2001 2001 (Seattle, WA), ACM, 519.
20. Kasper, L.R. *Splendid Table: Counter Intelligence (interview with Jofish Kaye)*, NPR, Minnesota Public Radio, St. Paul, MN, 2000.
21. Kautz, H., Allen, J., , 1986. pp 32-37. *Generalized Plan Recognition in Artificial Intelligence 1986* (Menlo Park, CA), AAAI Press, 32-37.
22. Kaye, J. *marco pollo*. website.
<<http://www.media.mit.edu/ci/projects/marcopollo.html>>, MIT Media Lab: 2000. Accessed August 15, 2001.
23. Kaye, J., N. Marsakis, M. Gray, A. Wheeler, and M. Hawley. *PC Dinners, Mr. Java and Counter Intelligence: Prototyping Smart Appliances for the Kitchen*. website. <Accessible online at <http://www.media.mit.edu/~jofish/ieee.paper/ieee.cga.jofish.htm>>, 1999. Accessed December 2000.
24. Kidd, C.D., Robert J. Orr, Gregory D. Abowd, Christopher G. Atkeson, Irfan A. Essa, Blair MacIntyre, Elizabeth Mynatt, Thad E. Starner and Wendy Newstetter. *The Aware Home: A Living Laboratory for Ubiquitous Computing Research* in Second International Workshop on Cooperative Buildings (Co-Build '99) 1999 (Pittsburg, PA).
25. Langmuir, J., et al. *Universal Kitchen Project*, Cooper-Hewitt National Design Museum, New York, NY, exhibited at "Unlimited by Design", 1998.
26. Larson, K. *House_n Living Laboratory White Paper*, MIT Department of Architecture, Cambridge, 2001, 7.
27. Maney, K. "Computers sink as kitchen appliance - again," *USA Today*. 3/29/00 03.B
28. Mundie, D.A. *Computerized Cooking*. website.
<<http://www.anthus.com/Recipes/CompCook.html>>, 1985. Accessed August 2001.
29. Ockerman, J.J., Narence J Najjar, J. Christopher Thompson. *Evaluation of a wearable computer performance support system.* in T. Muldner, T.C.R. ed. Educational Multimedia/Hypermedia and Telecommunications, Association for the Advancement of Computing in Education, Charlottesville, VA, 1997, 788-793.
30. Omojola, O., E.R. Post, M.D. Hancher, Y. Maguire, R. Pappu, B. Schoner, P.R. Russo, R. Fletcher and N. Gershenfeld. *An installation of interactive furniture*. IBM Systems Journal, 39 (3/4): 861-879, Fall 2000
31. Patten, J., H. Ishii, J. Hines, G. Pangaro. *Sensetable: a wireless object tracking platform for tangible user interfaces* in CHI 2001 (Seattle, WA), ACM Press, 253-260.

32. Plant, S. "The future looms: weaving women and cybernetics." in Featherstone, M., Roger Burrows. ed. *Cyberspace/cyberbodies/cyberpunk: cultures of technological embodiment.*, Sage, London, UK, 1995, 46-64.
33. Reas, C. *Iogami*. website. <www.io360.com/v2/yo/iogami>, io360.com: 1997. Accessed March 2001 at archive: <http://acg.media.mit.edu/people/creas/eat/iogami.html>.
34. Ridgway, L. "Counter Intelligence Cooks up Technology for the Kitchen," *i/s*. July/August 2000, 15(6):1-2
35. Sutherland, I.E. *Sketchpad: A Man-Machine Graphical Communication System*, Ph.D, MIT: Cambridge, MA, 1963
36. Underkoffler, J., Ishii, H. *Illuminating Light: An Optical Design Tool with a Luminous Tangible Interface* in CHI 1998, ACM Press, 542-549.
37. Verplank, W. *Idea Sketching Workshop, Massachusetts Institute of Technology*, unpublished, Cambridge, MA, 2001.
38. Want, R., P. Fishkin, A. Gujar, B. Harrison. *Bridging Physical and Virtual Worlds with Electronic Tags*. in *Computer Human Interactions 1999* (Pittsburgh, PA), ACM Press, 370-377.
39. Wellner, P. *Interacting with paper on the Digital Desk*. *Communications of the ACM*, 36 (7): 86-96, July 1993
40. Wieser, M., "The Computer for the 21st Century," *Scientific American*. September 1991, 265(3):94-103
41. Wisneski, C. *The Design of Personal Ambient Displays*, Master's thesis, MIT: Cambridge, MA, 1999

PHOTO CREDITS

Page 18

Drawing excerpted from <http://www.computer.org/history/index.html> , IEEE, 1996

Photo* excerpted from <http://home.clara.net/mycetes/babbage/>

Page 19

Photo* excerpted from <http://www.sun.com/960710/feature3>

Drawing, Life magazine, ©1945

Page 23

Photo, John Underkoffler , ©1997

Photo, James Patten, ©2000

Page 28

Photo, Webb Chappell, ©2000

Page 29

Cartoon, Jeff MacNelly, ©2000

Page 30

Advertisement, Honeywell Corporation, ©1969

Page 31

Photo* excerpted from <http://www.electrolux.com/screenfridge/external.htm>

Photo* excerpted from <http://www.wave-report.com/other-html-files/3Comcomdex.htm>

Page 34

Photo, Joseph Kaye, ©1999

Page 49

Screenshot excerpted from [33], Casey Reas, ©1997

Page 50

Image and photo excerpted from [29], T. Muldner, ©1997

Page 51

Screenshot excerpted from [8], Michael Eisenberg, ©1997

Page 54

Sketch excerpted from [12], Richard Fletcher, ©2000

Page 65

Photo, Leonardo Bonnani, ©2001

*Original artist and date of publication unknown.

All other photos and graphics created by Wendy G. Ju, ©2001