

Hardware Model of a Shipboard Zonal Electrical Distribution System (ZEDS):
Alternating Current/Direct Current (AC/DC)

by
Chad N. Tidd

B.S., Mathematics, State University of New York College at Brockport, 2001
B.S., Computational Science, State University of New York College at Brockport, 2001

Submitted to the Department of Mechanical Engineering and Systems Design and Management
in Partial Fulfillment of the Requirements for the Degrees of

Naval Engineer
and
Masters of Science in Engineering and Management

at the
Massachusetts Institute of Technology
June 2010

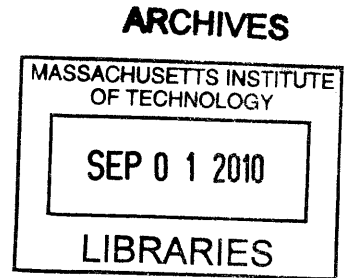

© 2010 Massachusetts Institute of Technology. All rights reserved

Signature of Author.....
Department of Mechanical Engineering & System Design and Management
May 7, 2010

Read by
Jim Paris/Zack Remscrim
Department of Electrical Engineering and Computer Science

Certified by
Steven B. Leeb
Professor of Electrical Engineering and Computer Science & Mechanical Engineering
Thesis Supervisor

Accepted by
Pat Hale
Director, Systems Design and Management Fellows Program
Engineering Systems Division

Accepted by
David E. Hardt
Chairman, Committee on Graduate Students
Department of Mechanical Engineering

Hardware Model of a Shipboard Zonal Electrical Distribution System (ZEDS):
Alternating Current/Direct Current (AC/DC)

by

Chad N. Tidd

Submitted to the Department of Mechanical Engineering on May 7, 2010 in Partial Fulfillment
of the Requirements for the Degrees of Naval Engineer and Masters of Science in Engineering
Management

ABSTRACT

A hardware model of a shipboard electrical distribution system based on aspects of the DDG 51 Flight IIA, Arleigh Burke class, 60Hz Alternating Current (AC) and the future direct current (DC), zonal electrical distribution system (ZEDS). These distribution boards were designed and built for the purpose of testing electrical system components at the Massachusetts Institute of Technology's Laboratory for Electromagnetic and Electronic Systems (LEES).

The combination of existing electrical generators and the newly created electrical distribution boards will provide a hereto unattained level of access for testing and evaluating a number of research topics currently being worked on at LEES. The level of reality inherent in this system will enable the user to refine experimental hardware and software in a safe and controlled environment. The user will benefit from a quicker product development process. Additionally, the ability to easily produce verifiable records to demonstrate the effectiveness/applicability of their individual experiments will help to progress research at LEES along the product development path.

Two 5 kW generators serve as electrical generation for the ZEDS benchtop emulator boards. The hardware models support experimentation with AC and DC ZEDS power loading and protection. The hardware models reflect the AC ZEDS architecture employed on the DDG-51 class destroyers. The emulator is a three phase electrical system with both port and starboard buses, a computer interface to control the generators and contactors or solid state relays through a graphic user interface (GUI). The system is capable of being configured and operated in a split plant, parallel or single generator plant configuration.

Thesis Supervisor: Steven B. Leeb

Title: Professor of Electrical Engineering and Computer Science & Mechanical Engineering

(This Page Intentionally Left Blank)

Acknowledgements

This research was funded through the Office of Naval Research's Control Challenge, ONR/ESRDC Electric Ship Integration Initiative and the Grainger Foundation, all of whom provided funding under the direction of Professor Steven B. Leeb; whose support and positive can do attitude greatly facilitated the progression of this work as well as my personal development as an engineer. I sincerely appreciate having been granted the opportunity to learn and work with him.

To Professor Pat Hale, thank you for setting a perfect example on how to lead, manage and strive for excellence in every aspect of your life. Your leadership is essential to fostering the loyalty, dedication and pride that enables the diverse student population within your department to be the very best systems engineers they can be. You never have a negative word to say, you always encourage and facilitate each of us to achieve our very best, fair winds and following seas.

To my Navy classmates, thank you for your camaraderie and sense of humor, without both of them my time here would have been far less entertaining.

To my SDM classmates over the past three years, thank you for allowing me to take part in your learning experience both inside and outside of the classroom. I will remember our time together fondly for years to come, best wishes to you all.

To my Grandmother Towse, thank you for your patience with me during the time when we lived with you. You have always been supportive of me and my efforts to better myself. You have been a constant source of inspiration in the face of adversity and loss, thank you.

To my mother and father, words cannot express my gratitude to you. I would not and could not have made it this far without your love, support, guidance, and discipline. Although, life is not always perfect, I would not ask to change any part of my childhood. All that I have achieved up till now and until I cease to exist was made possible by you, thank you for sharing in my triumphs and cushioning the blows of my failures, I love you.

Last, but certainly not least, to my wife, daughter and son thank you for your patience, support, and at times reminder to keep moving forward. You are the very foundation of any and all success that I have enjoyed in my short time with you. Without you in my life, to share my success, I could not have ever achieved the level of satisfaction and enjoyment that I have. You will never understand how helpful the simple gesture of a smile or a hug was to me, throughout this process, I love you and thank you for everything.

(This Page Intentionally Left Blank)

Finally I would like to dedicate this work to the memory of my Grandmother and Grandfather
Lillian and Norman Tidd

(This Page Intentionally Left Blank)

Table of Contents

1.0 INTRODUCTION.....	15
2.0 SHIPBOARD ELECTRICAL GENERATION AND DISTRIBUTION OVERVIEW	18
2.1 US NAVY SHIPBOARD ELECTRICAL GENERATORS	18
2.1.1 Normal Operations.....	19
2.1.2 Monitoring	19
2.1.3 Generator Control	19
2.2 SHIPBOARD ELECTRICAL DISTRIBUTION CONFIGURATIONS.....	20
2.2.1 Radial Distribution	21
2.2.2 Ring Bus Configuration.....	22
2.2.3 Alternating Current Zonal Electrical Distribution Systems	23
2.3 MAJOR COMPONENTS OF AN ELECTRICAL DISTRIBUTION SYSTEM.....	28
2.3.1 Electrical Switchboards	28
2.3.2 Switches	29
2.3.3 Circuit Breakers	31
2.3.4 Fuses	33
2.3.5 Load Centers	33
2.3.6 Power Conversion Equipment	34
2.4 ELECTRICAL DISTRIBUTION OPERATION	35
2.4.1 Split Plant Operations	35
2.4.2 Parallel Plant Operations	35
2.5 DDG 51 POWER RELIABILITY AND LOAD SHEDDING	37
2.5.1 Non-vital loads	37
2.5.2 Semi-Vital Loads.....	37
2.5.3 Vital Loads.....	38
2.5.4 Load Shedding.....	38
3.0 OTHER ELECTRICAL GENERATION PLANTS AND DISTRIBUTION SYSTEMS	40
3.1 HYBRID PLANTS.....	40
3.2 INTEGRATED POWER SYSTEMS	40
3.2.1 MVAC Systems	41
3.2.2 HFAC systems	41
3.2.3 MVDC Systems	42
3.3 IPS JUSTIFICATION	43
3.4 RELEVANCE OF IPS.....	47
4.0 BACKGROUND WORK.....	48
4.1 NON-INTRUSIVE LOAD MONITORING OVERVIEW	48
4.1.1 Current Sensors	48
4.2 THE HARDWARE MODEL OF A SHIPBOARD GENERATOR.....	49
4.2.1 The Generator	49
4.2.2 The Prime Mover.....	50
4.2.3 Input/output K-8061 USB Board	52
4.2.4 Hardware Model of a Shipboard Generator Conclusions.....	53
4.3 MODELING FOR SHIP POWER SYSTEM EMULATION.....	53

5.0 THE ZEDS HARDWARE MODEL ARCHITECTURE.....	55
5.1 CLIENT NEED AND RESOURCES	55
5.2 CONCEPTION AND MODEL BUILDING.....	56
5.3 COMPONENT LEVEL ANALYSIS OF ALTERNATIVES	58
5.4 INTERFACE DESCRIPTION	60
5.5 ENGINEERING	61
5.6 PRODUCTION	62
5.7 TESTING/CERTIFICATION	63
5.7.1 <i>The Short Circuit Test</i>	63
5.7.2 <i>Current Sensors Alternative Testing/Comparison</i>	64
5.7.3 <i>Solid State Relay and Solenoid Operated Contactor Comparison Testing</i>	67
5.7.4 <i>NILM Power Monitoring on a Ring Bus Configured Distribution System</i>	71
6.0 THE SHIPBOARD GENERATION AND DISTRIBUTION HARDWARE MODELS	74
6.1 THE CURRENT CONFIGURATION OF THE HARDWARE MODEL OF A SHIPBOARD GENERATOR	74
6.1.1 <i>The DC Motor Power Supply</i>	74
6.1.2 <i>The Field Winding Power Supply</i>	74
6.1.3 <i>Addition of a Second Generator</i>	74
6.1.4 <i>Frequency Output</i>	74
6.1.5 <i>Preventing the Backflow of Power to the DC Power Supplies</i>	75
6.2 THE AC ZEDS HARDWARE MODEL.....	76
6.2.1 <i>The Circuit Breakers</i>	79
6.2.2 <i>Control System for Circuit Breakers</i>	79
6.3 THE DC ZEDS HARDWARE MODEL.....	81
6.3.1 <i>Circuit Breakers</i>	83
6.3.2 <i>Rectification and Filtering</i>	83
7.0 CONCLUSION.....	86
7.1 ADDITIONAL WORK.....	88
7.1.1 <i>Circuit Breaker Emulation</i>	88
7.1.2 <i>Automatic Paralleling of the Generator</i>	89
7.1.3 <i>GUI and Control Improvements</i>	89
7.2 FUTURE STUDIES.....	89
7.2.1 <i>Doubly-Fed Machine</i>	89
7.2.2 <i>Non Intrusive Load Monitoring</i>	89
BIBLIOGRAPHY.....	91
APPENDIX I – OPERATOR MANUAL.....	93
APPENDIX II – CONTACTOR AND SSR CONTROLLER CODE.....	111
APPENDIX III - CONTROL SYSTEMS OVERVIEW.....	126
APPENDIX IV – SYSTEM MODELING	130

List of Tables

Table 1: Percentage of Speed Regulation versus Voltage Variation [3]	20
Table 2: Generator Data Comparison	50
Table 3: DC Permanent Magnet Motor Characteristics [12]	51
Table 4: STC-5 Generator Characteristics from Testing [10]	54
Table 5: LA 55-P and HTR 50-SB Comparison Chart.....	65
Table 6: SAP 4840D SSR and P31E Contactor Data	67
Table 7: PID Term Adjustment Affects.....	129

List of Figures

Figure 1: AC ZEDS Hardware Model Concept	16
Figure 2: DC ZEDS Hardware Model Concept	16
Figure 3: MFM-III addressing, locations and signal inputs for DDG 91 [1]	17
Figure 4: Radial Distribution System with Dual Purpose Generators [4].....	22
Figure 5: DDG 51's Radial Electrical Distribution System [2]	23
Figure 6: AC ZEDS for a Surface Combatant Ship [4]	24
Figure 7: DDG 79-90 ACZEDS Layout [5]	26
Figure 8: DDG 91+ AC ZEDS Layout [6].....	27
Figure 9: Example SABT Configuration [6]	30
Figure 10: SABT basic functional diagram and view of cabinet	31
Figure 11: NAVSEA Operating Speed Profile for DDG 51 (NAVSEA 2002)	44
Figure 12: DDG 51 Individual 1998 Yearly Underway Speed Profiles (Rodeghiero et al. 1999)..	44
Figure 13: EHP versus Speed Data from a notional DDG 51 ship hull in ASSET	46
Figure 14: Hardware Model of a Shipboard Generator, MIT LEES, 2009	49
Figure 15: Mindong STC-5 Generator Name Plate [12]	50
Figure 16: DC Motor Configuration.....	51
Figure 17: DC Motor Name Plate	51
Figure 18: K-8061 USB Board	52
Figure 19: The Product Waterfall [14]	55
Figure 20: AC ZEDS Hardware Model Concept	57
Figure 21: DC ZEDS Hardware Model Concept	57
Figure 22: MFM-III addressing, locations, and signal inputs for DDG91+ [1]	58
Figure 23: AC ZEDS Hardware Model Connection Matrix.....	61
Figure 24: Source and Load Plugs and Receptacles [15].....	61
Figure 25: Short Circuit Test Configuration	63
Figure 26: Short Circuit Test Data	64
Figure 27: LA 55-P Transducer [16].....	65
Figure 28: HTR 50-SB Transducer [16]	65
Figure 29: LA 55-P and HTR 50-SB Current Transducer Comparison.....	66
Figure 30: Transient Comparison of LA 55-P and HTR 50-SB.....	66
Figure 31: Aggregate Power Test Setup.....	69
Figure 32: Current Flow to the Load Through the SSRs.....	70
Figure 33: Aggregate Current Data Using Solid State Relays.....	71
Figure 34: Individual Current Data Plot	72
Figure 35: Combined (A and B) Load Current and Source (C) Current Comparison.....	73
Figure 36: New Frequency Processing Circuit [17]	75
Figure 37: HEXFREDTM Diode.....	76

Figure 38: DC Motor Electrical Connection Diagram	76
Figure 39: AC ZEDS Architecture	77
Figure 40: AC ZEDS Hardware Board Shown Setup for the Aggregate Power Test	78
Figure 41: MATLAB GUI for Circuit Breaker Remote Operation	79
Figure 42: USB Interface and IC Chip Layout for the Circuit Breaker Control Board	79
Figure 43: AC ZEDS Circuit Diagram (1 of 2).....	80
Figure 44: AC ZEDS Circuit Diagram (2 of 2).....	80
Figure 45: Electrical Diagram of the DC ZEDS Hardware Model.....	81
Figure 46: DC ZEDS Hardware Model.....	81
Figure 47: DC ZEDS Control Circuit.....	82
Figure 48: DC ZEDS Control Circuit Diagram	82
Figure 49: Passive Rectifier No Filter	85
Figure 50: Passive Rectification with Filtering	85
Figure 51: Active Rectification Circuit.....	85
Figure 52: Wave Form of a Passive Rectifier with no Filter	85
Figure 53: Wave Form of Passive Rectifier with Filtering	85
Figure 54: Wave Form of an Active Rectifier	85
Figure 55: Motor Load Voltage Data.....	87
Figure 56: Lighting Load Voltage Data	87
Figure 57: Source to Bus Voltage Data	88
Figure 58: Open Loop Controller	126
Figure 59: Feed-Forward Controller	127
Figure 60: Closed Loop Controller.....	127
Figure 61: A Closed Loop PID Controller	128

(This Page Intentionally Left Blank)

1.0 Introduction

At MIT's Laboratory for Electromagnetic and Electrical Systems (LEES), research into Non-Intrusive Load Monitoring (NILM) has branched into numerous areas including energy scorekeeping, diagnostics, and power system protection.

One area of interest in NILM research involves power monitoring of the electrical distribution system onboard ships. One goal is to provide an affordable and simple method to aid or enhance existing systems like the Multi-Function Monitor (MFM) III to control the configuration of the electrical distribution system. Two functions that the NILM may have a significant impact on include, but are not limited to, increasing efficiency by managing the load shared between generators, and prevention or mitigation of damage caused by electrical faults.

One hurdle to conducting this research is the difficulty associated with testing the NILM and associated software/hardware in a realistic environment. As a result, a benchtop hardware emulator of a shipboard electrical distribution system was developed in conjunction with this thesis. The goals of this thesis were to:

1. Design two benchtop electrical distribution emulators based on a review of existing ship power systems
2. Construct and test the emulators
3. Document experiments while using the emulators
4. Provide a complete operators manual

Figures 1 and 2 below are initial design drawings of the alternating current (AC) and direct current (DC) zonal electrical distribution system (ZEDS) and were based on Figure 3 from [1].

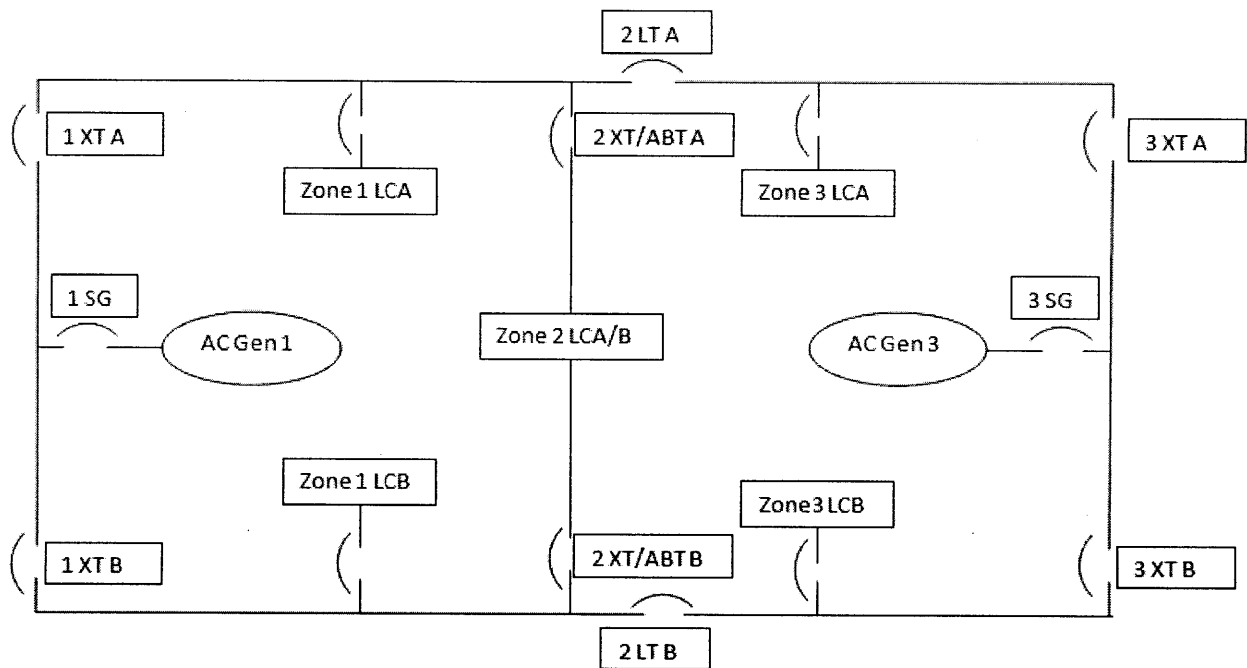

Figure 1: AC ZEDS Hardware Model Concept

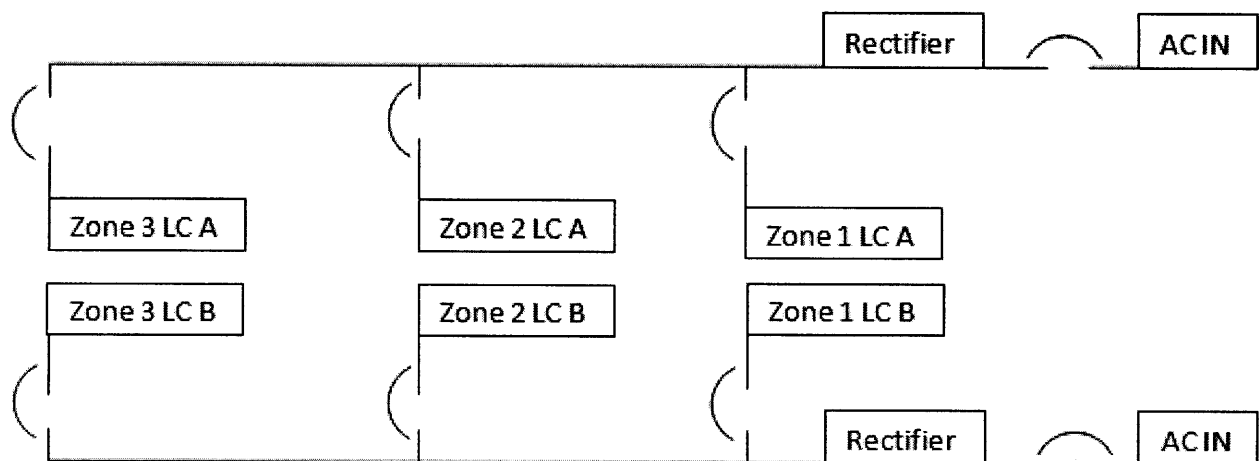

Figure 2: DC ZEDS Hardware Model Concept

LEGEND: Circuit Breaker

LC = Load Center XT = Cross Tie Breaker LT = Longitudinal Tie Breaker SG = Generator Breaker

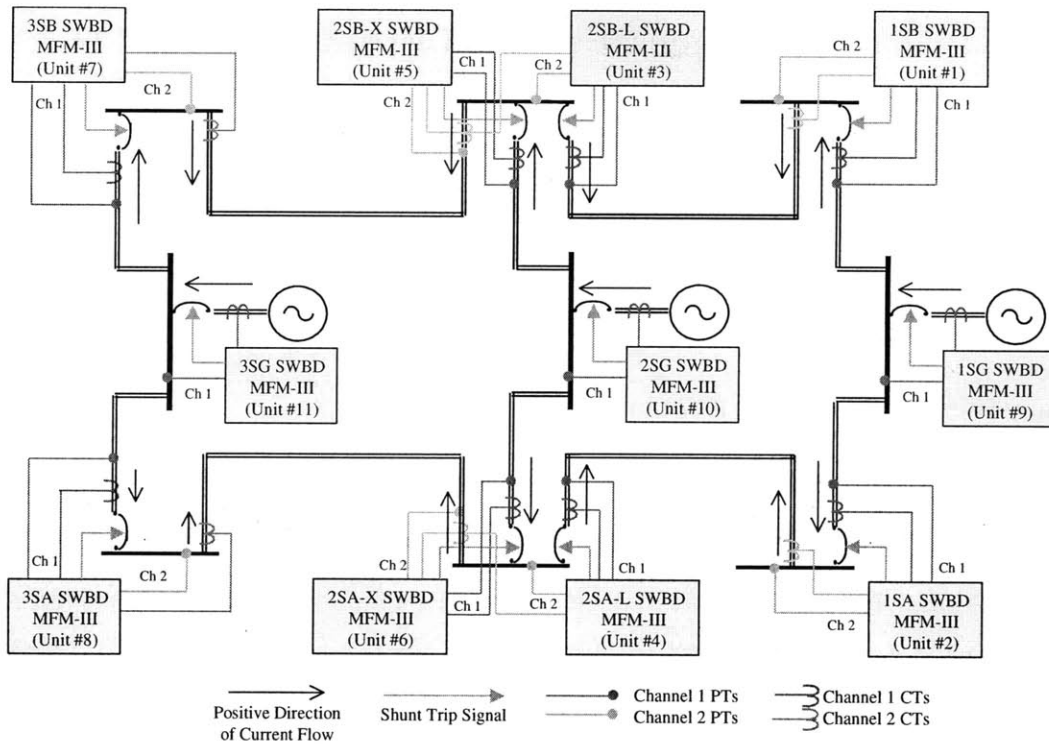

Figure 3: MFM-III addressing, locations and signal inputs for DDG 91 [1]

2.0 Shipboard Electrical Generation and Distribution Overview

This chapter reviews shipboard electrical generation and distribution systems, relevant to the power systems work ongoing in LEES. Specific attention is given to the DDG 51 class ships' electrical generation and distribution system, because the AC ZEDS emulator is based on this class of ship.

2.1 US Navy Shipboard Electrical Generators

US Navy shipboard generators are typically AC synchronous type generators with rotating fields coupled to one of the following prime movers: a steam turbine (STG), a diesel engine (DG), or a gas turbine engine (GTG). Generators in use onboard US Navy ships have either salient pole rotors or cylindrical rotors based on their speed less than 3,600 rpm or greater than 3,600 rpm respectively [3]. For the most part, USN Generators produce 450V at 60Hz.

The DDG 51 Arleigh Burke class guided missile destroyers have three Allison 501-K34 gas turbine engines each coupled to a salient pole generator either model number AG9130 or AG9140 [2]. The gas turbine engine that drives the generator spins extremely fast therefore, a reduction gear is used to drive the generator at a steady 1,800 rpm, for 60 Hz.

The field windings of a typical AC generator are excited by a DC source. On DDG 51 class ships and typically on ships in general this is accomplished through self excitation: when a portion of the generators output supplies the field winding power. Self excitation is normally self regulating and requires some form of rectification to convert the AC output of the generator to DC input for the field windings. Another, common method is the use of an external system that either provides controllable DC power directly to the field windings.

The generators used onboard DDG 51 class ships are required to meet specific design specifications. One example, when the full rated load is applied to the generator, frequency is allowed to drop by no more than 2 percent or 1.2 Hz for a 60 Hz system and the recovery time may not exceed 1.5 seconds. Recovery is defined as returning to within $\pm 1\%$ of the rated frequency or $\pm .6$ Hz for a 60 Hz system.

2.1.1 Normal Operations

Shipboard Generators are operated in accordance with reference [3], section 310-1.5 Operation of AC Generators. DDG 51 class ships are designed to operate with two generators online and one in standby. The two operating generators are either configured to run together on a common bus, in parallel, or electrically isolated from each other in a split plant configuration; both configuration types will be discussed in 2.4 Electrical Distribution Operation.

2.1.2 Monitoring

The generators electrical output is monitored closely and this information is used to ensure the safe operation of the generator. The monitoring of the electrical distribution system is one area in particular that has motivated this thesis project.

Generator monitoring is available at the local control station and provides voltage, current, frequency, and power information. Voltage is measured using a voltmeter, current is measured with an ammeter, frequency is measured with a frequency meter and power is measured with a kilowatt meter.

Ground detection monitoring is available at the load centers where three lamps are connected between each phase and ground. When a test push button is depressed the circuit is closed and the lights will be lit. If a ground exists the phase that is grounded will not light or will be less bright than the other phases.

2.1.3 Generator Control

Generator control of voltage and frequency is a major concern for design engineers of electrical generation and distribution plants. The primary design concern is reliability. Frequency control is commonly established by controlling generator speed and voltage control is commonly established by varying voltage and current to the field windings.

DDG 51 class ships use a closed loop feedback, proportional and integral (PI) control system; see Appendix III for a review of basic control systems.

Frequency control is established through the use of the Electro-Hydraulic Governor Actuator (EHGA). The EHGA automatically adjusts the fuel flow to the GTG during normal operations and is the primary means to control speed and the resulting frequency of the generator output. The centrifugal governor is the backup system for controlling frequency of the generator. In the advent of a EHGA failure, the fuel valve will automatically go to the fully open position and the centrifugal governor will limit the gas turbine rpm to 15,000. The gas turbine speed of 15,000 rpm is reduced by the reduction gear to a generator speed of roughly 1860 rpm for an output frequency of roughly 62 Hz.

Voltage is regulated either manually or automatically. Manual control is accomplished by using the motor controlled adjustable rheostat. Automatic control is accomplished by the automatic voltage regulator in the excitation control panel (EXCOP).

When controlling voltage, the frequency of the output and the excitation voltage, to the field windings, both play a part in determining the output voltage. However, the majority of voltage control is done by controlling the excitation voltage to the field windings.

Table 1 shows permissible operating ranges for the DDG 51 prime movers.

Table 1: Percentage of Speed Regulation versus Voltage Variation [3]

Prime Mover	Minimum permissible speed regulation (percent)	Combined unit	
		Voltage rise full load to no load	Voltage drop no load to full load (percent)
Turbine	3.5	7 to 8	9 to 12-1/2
Diesel engine ¹	4.0	7 to 8	9 to 12

¹Certain diesel engines have isochronous or constant speed governs. The speed regulation on these should be practically zero.

2.2 Shipboard Electrical Distribution Configurations

An electrical distribution system is composed of the equipment needed to transport electrical power from a source to a load. In the case of a shipboard system, the source is an electrical generator normally coupled to a prime mover that converts fuel into mechanical work to turn

the generator and produce electrical power. There are many different types of loads that connect to the distribution system. These include, but are not limited to, systems for power storage, distribution, and conversion. The purpose of which is to use electricity in a useful way, for instance, creating light, producing radio frequency (RF) signals, powering electronics, and rotating a pump shaft or similar device.

Another key feature of a distribution system is the level of protection it provides to the users and the equipment connected to it. One difference between a shipboard electrical distribution system and a house hold distribution system is the method used to ground the system. Household distribution systems utilize an earth ground in contrast to a shipboard electrical distribution system that is considered ungrounded. Although shipboard electrical distribution systems are ungrounded, there are some instances where a ground to the ship's hull is required. This is normally accomplished through the secondary of a Delta-Wye transformer [4].

Although the distribution system could consist of a simple connection between a source and the load via a single conducting cable, this type of system is not practical in modern shipboard designs. This is due to the large number of loads that require power, the high current these loads draw, and safety consideration for personnel and equipment. Three alternative distribution methods that provide increased safety and enhance power continuity are described below.

2.2.1 Radial Distribution

The simple distribution system described in the last paragraph of the previous section would be considered a radial distribution system with a single node. The term radial is used to denote that the loads radiate outward from a single connection point. It should be understood that in almost every electrical distribution system there is some portion configured as a radial distribution.

Radial electrical distribution systems are characterized by an expanding network of cabling/loads from a central point. In modern electrical distribution systems like that found on

DDG 51 class ships, the radial distribution starting point begins at the load centers or switchboards. The load centers and switchboards are located in a manner that is meant to reduce ships' cabling. This is done by allowing a closer central access point to the bus for larger loads. Figure 4, depicts a general shipboard ring bus (dotted line) with radial distribution from the AFT and FWD ship service (SS) and emergency (EMER) distribution panels.

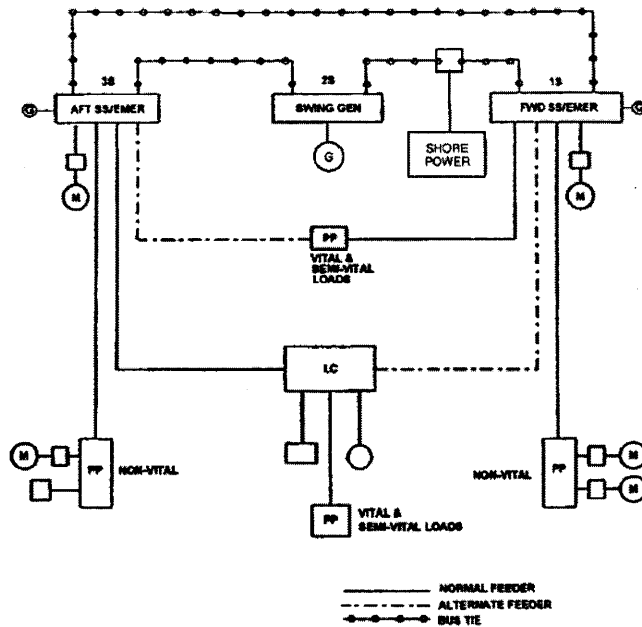

Figure 4: Radial Distribution System with Dual Purpose Generators [4]

2.2.2 Ring Bus Configuration

A ring bus configured distribution system is defined by the ability to form a single main power bus loop. Figure 4, provides a good depiction of how a ring bus, the dotted line, is formed. All DDG 51 class electrical distribution systems can be configured in as ring bus. In a ring bus distribution system, power may flow to a load through more than one path and multiple generators may share the load. This capability increases power continuity since the load is not tied to just one source. A depiction of the DDG 51 hull number 77 and below radial distribution system is shown in Figure 5.

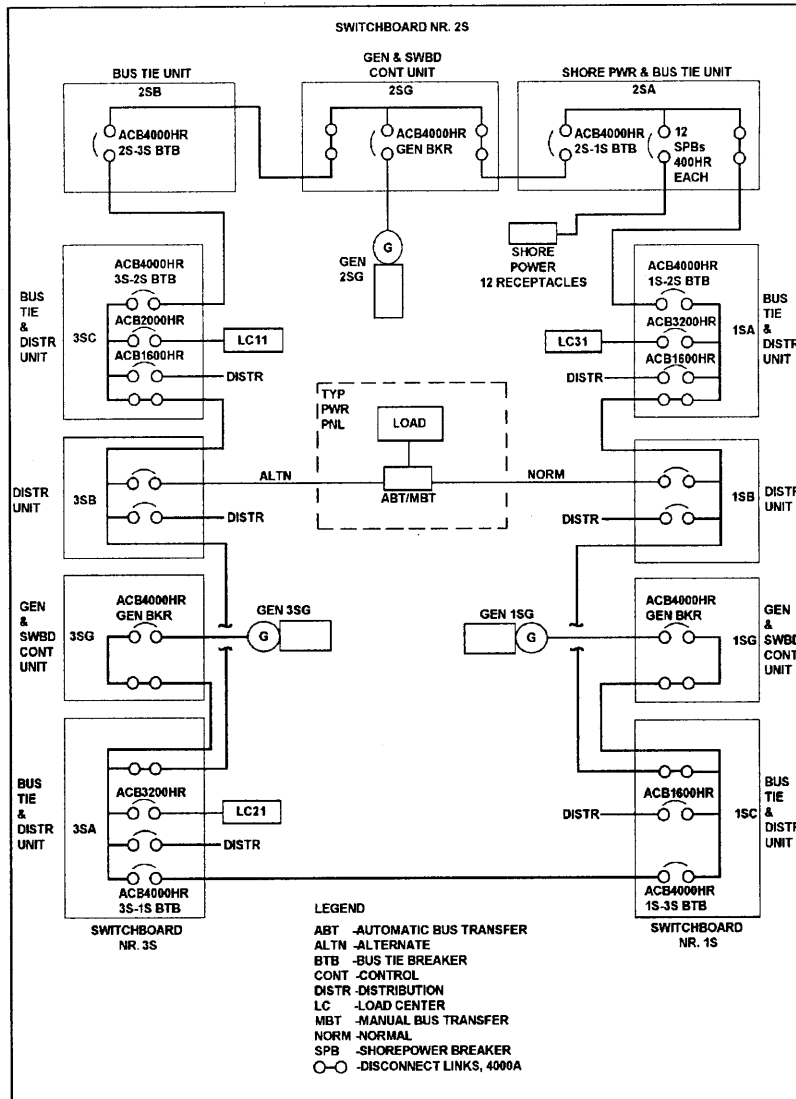

Figure 5: DDG 51's Radial Electrical Distribution System [2]

2.2.3 Alternating Current Zonal Electrical Distribution Systems

The AC ZEDS used on the DDG 51 class ships, hull number 79 and higher, is distinctly different from distribution system architectures on most other US Navy ships. The AC ZEDS is able to be configured as a ring bus and utilizes a radial distribution methodology from the load centers. The primary difference between the AC ZEDS and the traditional radial distribution systems is the ability to segment the system into two distinct, port and starboard, bus rails. Additionally, the bus rails and the ships' electrical loads are geographically segmented into individual zones with co-located load centers. In the older distribution systems a load was not located based on

the location of its load center and as a result could be located rather long distances away from where it actually accessed the bus. This method tended to create long cable runs and multiple water tight boundary penetrations, this was particularly true when adding equipment after final design and construction.

As a result, the AC ZEDS architecture is becoming increasingly popular among smaller surface combatants like DDG 51. Figure 6 is a representation of a typical surface combatant AC ZEDS layout [4]. The AC ZEDS architecture is based on the placement of the load centers where, generally speaking, two or more load centers make up a zone. However, there is a trade off between producibility and complexity.

As an example, older DDG 51 designs only had three load centers and as a result, many very long electrical cable runs with multiple water tight boundary penetrations. This had a negative impact on producibility that translated to increased production costs. However, monitoring and controlling the three switchboards was fairly straight forward and in many cases could be done manually. Zonal electrical distribution systems, on the other hand, have significantly less water tight penetrations and significantly more load centers. Current DDG 51 class ships are being built with 22 load centers. This increases the producibility of the ship while at the same time increasing complexity of monitoring and controlling the electrical distributions system.

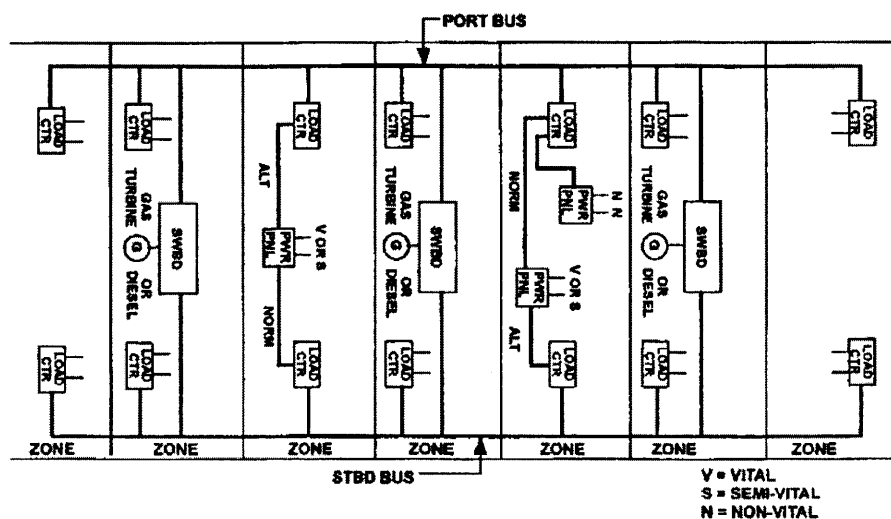

Figure 6: AC ZEDS for a Surface Combatant Ship [4]

The DDG 51 class ships currently operating with an AC ZEDS architecture include hull numbers 79 and above. DDG 79-90 are configured as shown in Figure 7, with 15 load centers. DDG 91 and above are configured as shown in Figure 8, with 22 load centers [6].

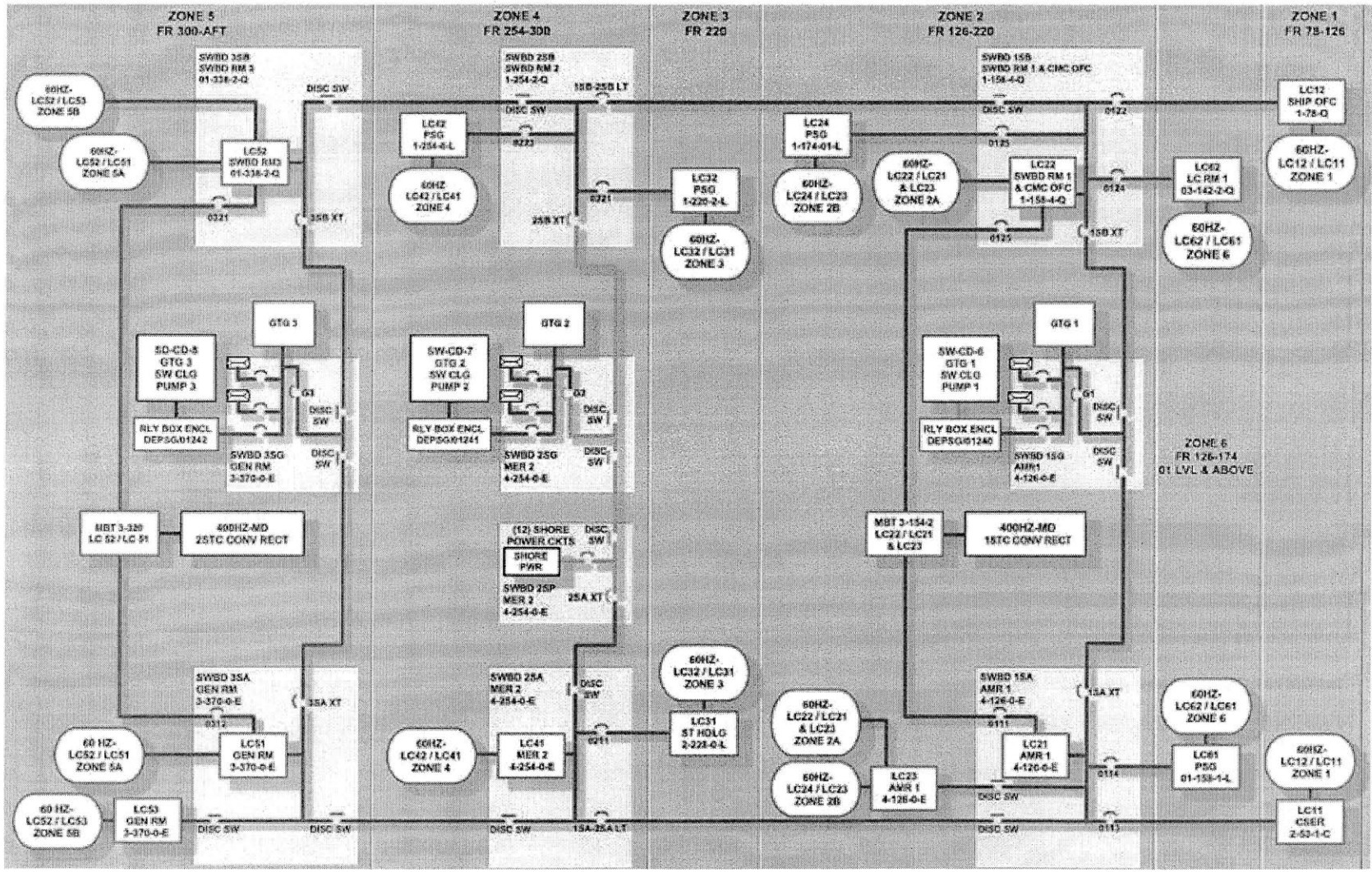

Figure 7: DDG 79-90 ACZEDS Layout [5]

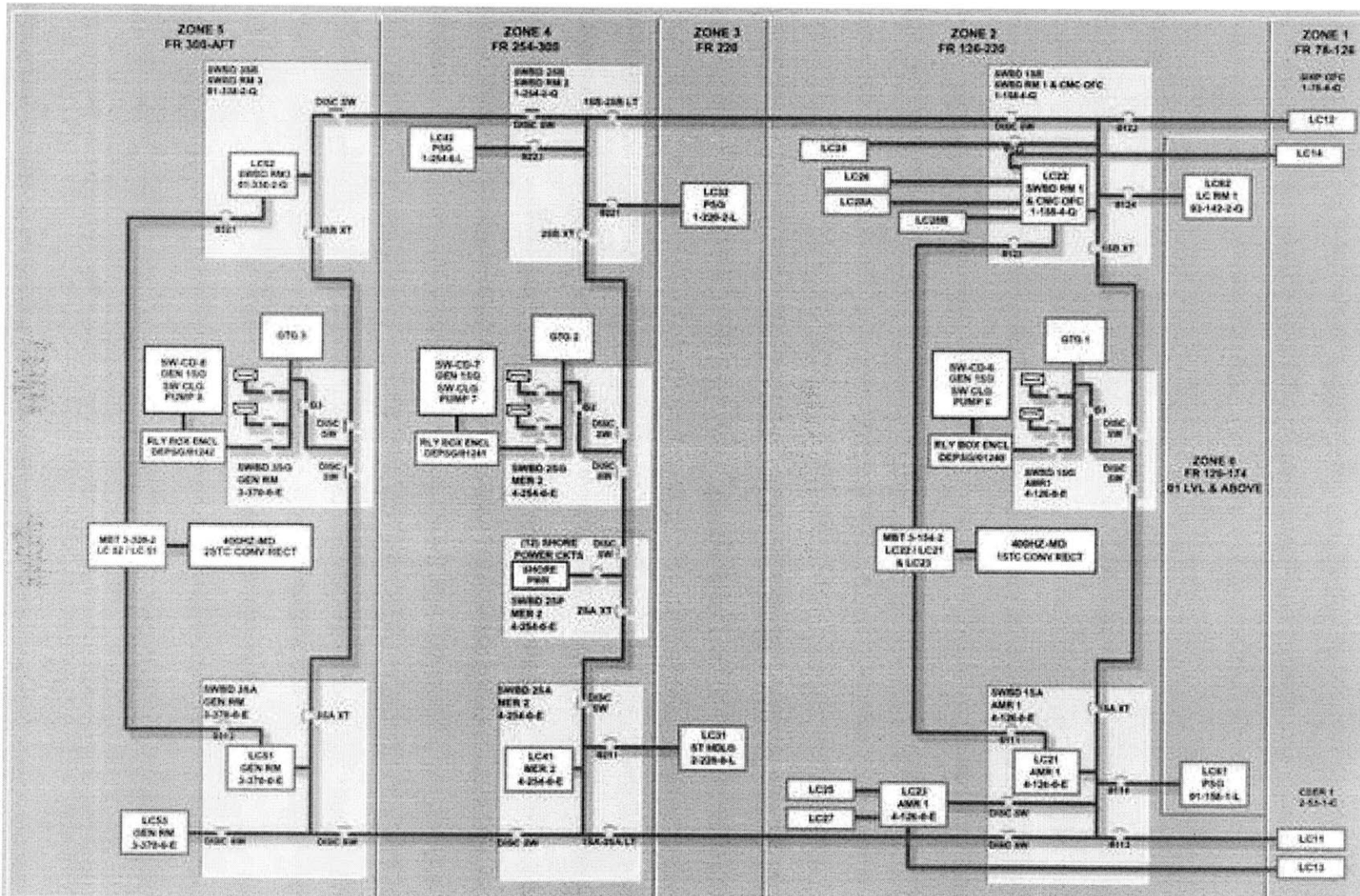

Figure 8: DDG 91+ AC ZEDS Layout [6]

2.3 Major Components of an Electrical Distribution System

Safely producing and distributing power requires specific equipment including but not limited to: Electrical Switchboards, Switches/Circuit Breakers, Fuses, Load Centers, and Power Conversion Equipment.

2.3.1 Electrical Switchboards

An electrical switchboard is a collection of panels and devices used to direct/connect the flow of electrical power from a source to a bus, a source to load, a bus to bus, or a bus to a load. A typical electrical switchboard is made up of several panels with breakers, fuses, switches and bus bars. In some cases the switchboard may incorporate control systems. The control systems are used to vary the voltage or frequency of the power being generated and used or for changing the voltage and frequency of the oncoming generator when paralleling one or more generators onto a common bus.

The electrical distribution systems on DDG 77 and below, pictured in Figure 5, has three switchboards. There are four distinct sections that are combined in various ways to make up the three switchboards. The SG section contains the generator breaker, generator controls, switchboard controls, and protective devices. Each generator has a single SG section devoted to it. The SA section contains a Bus Tie Breaker (BTB) and breakers for distribution of various major loads. The Nr. 2 switchboard's SA section is configured slightly different with a BTB and the shore power breakers. The SB section contains breakers for distribution of various major loads. The Nr. 2 switchboard's SB section is different, with only one BTB. The SC section contains a BTB and breakers for distribution of various major loads. Nr. 2 SWBD does not have a SC section [2].

The electrical distribution systems on DDG 79 and above, pictured in Figure 7 and Figure 8, have three sections that form the switchboards. The SG section is identical to the DDG 77 and below in terms of equipment and function. The SA and SB sections contain the XT circuit breakers which are opened or closed to provide power to either the port or starboard

buses. Additionally the 2SA and 2SB sections contain the longitudinal breakers (LB) and circuit breakers for the associated load centers [5, 6].

2.3.2 Switches

An electrical switch is any device that has the ability to close or open a circuit by connecting or disconnecting two separate conductors. A switch is classified by the number of “poles” and “throws” or “ways”. A “pole” refers to the number of circuits controlled by the switch. “Throws” and “ways” refer to the number of different positions the switch can be positioned in. When a switch has only one or two positions, the term “throws” is used. When a switch has three or more positions, the term “ways” is used. A typical wall mounted light switch is a single pole single throw switch. A common industrial motor start switch is a three pole single throw switch. Switches can be operated manually or remotely. When a switch is actuated by another electrical circuit, it is called a relay.

An important feature in high wattage switches is the ability to quench an electric arc when opening and closing the circuit. An arc forms when opening a switch as the air between the contacts is ionized and gas plasma is formed. The gas plasma is very hot and represents a significant fire hazard. There are multiple ways to extinguish the electrical arc; most techniques involve simply expanding the length of the arc until it breaks down. Another method involves submersion of the contacts in a fluid such as mineral oil to prevent arcing [4]. When closing a switch, an arc is also able to form, but this does not present as difficult a problem since the arc will extinguish as soon as the contacts touch each other.

The number and variety of electrical switches on a DDG 51 class ship are too numerous to treat in full detail, however there are three specific types of switches important to this thesis: Manual Bus Transfer (MBT), Automatic Bus Transfer (ABT), and Static Automatic Bus Transfer (SABT) switches. Circuit Breakers, another important type of switch, are discussed separately in 2.3.3 because the primary function of a circuit breaker is different.

The ABT and MBT units are employed on all DDG 51 class ships and SABT units are employed aboard DDG 79 and higher.

The ABT and SABT units provide a relative guarantee that power will be available to vital loads if the primary bus is out of service. Both are three pole two throw automatic switches that transfer the load too one of the two busses. They are connected to the primary and alternate bus rails as shown in Figure 9. L-3 Power Paragon manufactures the SABT and Figure 10, taken from the manufactures web page, shows the SABT basic functional diagram and an actual picture of the internal view of a SABT cabinet.

The ABT and SABT switches are located adjacent to the equipment they serve. They normally switch to the alternate power source when the normal power source dips below 60-70% of the rated capacity for .3-.5 seconds. The ABT and SABT will normally switch back to the normal power source after detecting power from the normal source has achieved between 85-95% of the rated capacity. The SABT unit uses solid-state devices to provide the fast switching (4-8ms) whereas the ABT uses electro-mechanical monitoring and control devices for a slightly slower switching time. Both utilize a BREAK-before-MAKE operation to prevent connecting the two input sources out of phase. Both units can also be operated in manual mode [5, 6].

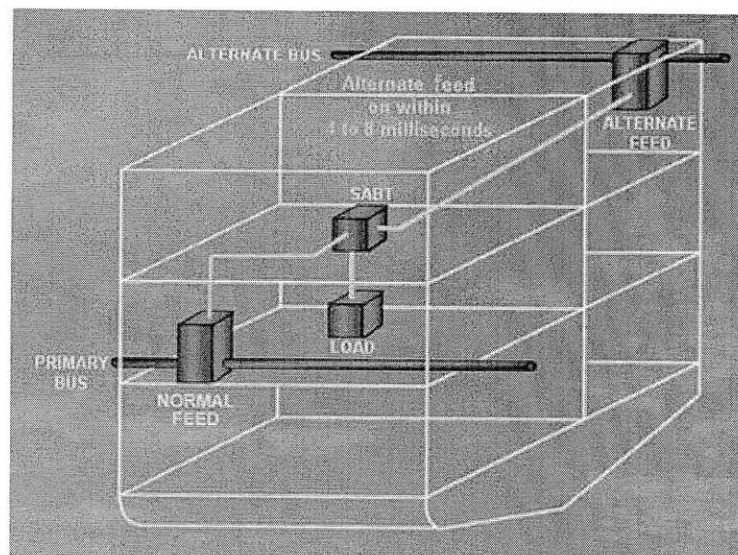

Figure 9: Example SABT Configuration [6]

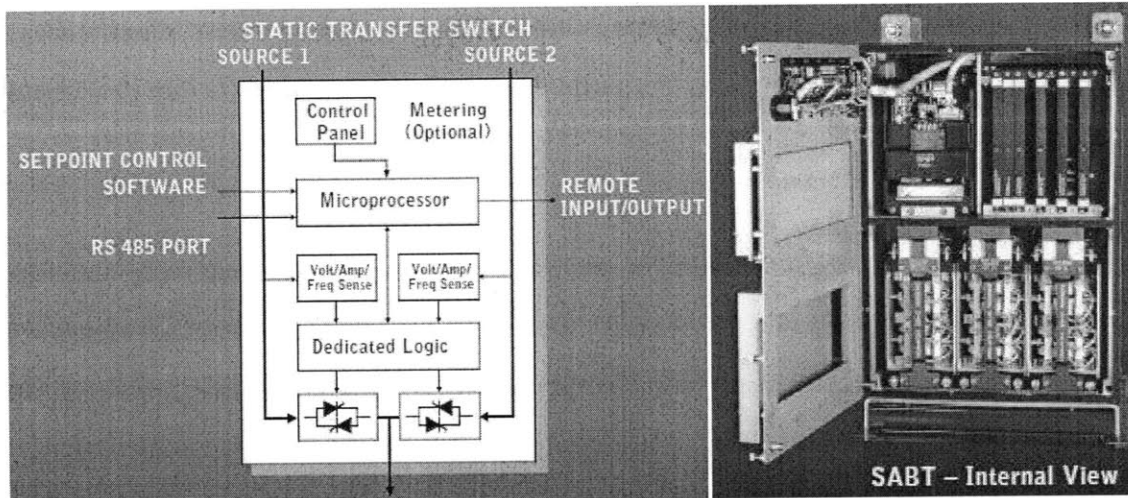

Figure 10: SABB basic functional diagram and view of cabinet¹

2.3.3 Circuit Breakers

A circuit breaker is a type of switch that is either automatically or manually operated and is designed to protect an electrical circuit from damage due to excessive current. Some basic characteristics include the ability to reset the switch after the breaker is opened (the switch should not be damaged by the current that caused it to trip), the ability to open and close the breaker either manually or remotely, and an arc quenching capability to minimize or prevent damage to the breaker and reduce the possibility of creating a fire. Circuit breakers used for shipboard applications in the US Navy include: the automatic carbon break (ACB), automatic quenched break (AQB), non-automatic quenched break (NQB), automatic low voltage breaker (ALB), and non-automatic low voltage breaker (NLB) [4].

The ACB has conductors with carbon coated tips to protect the current carrying portion of the conductors, when the breaker is opened. When the ACB is opened an arc is developed that is ruptured as the distance between the carbon tips expands. This protects the silver coated, current carrying portion, of the contacts from burning. This breaker is typically used for high power connections, such as connecting of the ship service and emergency generators to the power distribution busses [4].

¹ L-3 Power Paragon online product document:
<http://www.powerparagon.com/pdfs/Bulletin%20443%20SABB%2009.pdf>

The AQB and NQB breakers utilize magnetic influence to draw the arc into an electrically insulated, slotted steel box where the arc is substantially lengthened and cooled, to disrupt the arc [4].

The ALB and NLB breakers are used for low voltage circuits ranging from 5VDC-125VAC or VDC. A typical application includes circuit breaker protection of one or more lighting panels or 120V receptacles [4].

Circuit breakers are sized based on the maximum fault current that the electrical circuit can handle without being damaged.

Current DDG 51 class ships employ electronically actuated ACB type breakers for the Generator Breakers (GB or SG), Bus Tie Breakers (BTB) or Cross-Tie (XT) breakers, Longitudinal-Tie (LT) breakers, and in some cases Load Center (LC) Breakers. Although various systems throughout the ship utilize AQB, NQB, ALB and NLB type circuit breakers, in regard to this thesis, the ACB breakers are of particular interest. This is because they provide the ability to remotely or in some cases automatically reconfigure the distribution system.

2.3.3.1 ACB Functional Details

The primary function of any breaker is overload protection. The ACB breaker provides overload protection through the use of individual magnetic strips that open the circuit breaker when excessive current across the breaker is experienced. The magnetic strips work on an inverse time delay principle: the larger the current overload, the quicker the circuit opens.

The ACB breaker must actuate quickly when opening and closing, to accomplish this opening and closing springs are used. When the ACB is in either the opened or closed position both of the springs are compressed and latched.

To close the ACB circuit breaker a remotely initiated command signal from either the electric plant control console (EPCC) or the switchboard is generated. This provides the signal to allow 115VAC from either side of the circuit breaker to actuate a solenoid that opens the latch on the

closing springs. This closes the ACB circuit breaker very quickly. Then a 115 VAC motor is used to compress the closing springs in preparation for opening. The ACB circuit breaker is opened in a similar manner [4].

The automatic operations, described above, both require 115 VAC to occur. If there is no voltage or there is a failure in the circuit breaker, the charging springs can be charged manually using a jacking bar. Manual breaker operation is only used in an emergency. Normal operation is in the remote automatic mode from the EPCC or the SWBD [4].

2.3.4 Fuses

A fuse is an over current protection device in an electrical circuit that passes normal operating current and, for a short time, can pass current that exceeds normal operating parameters. When the current limit is exceeded for a long enough period of time, the fuse fails and interrupts current flow in the circuit, typically by melting an internal metal strip. Since the fault condition physically damages the fuse, it must be replaced when it blows.

There are three main fuse characteristics, or types, in use onboard US Navy ships: A, normal blowing; B, time lag (slow blowing); and C, very high interrupting capacity (100,00 amperes) [4].

A fuse is rated by the amount of steady state amperes it can pass without damaging the fuse. Fuses with the C characteristic are only used when the available fault current exceeds the maximum interrupting capacity of A and B fuses, 10,000 amperes [4].

2.3.5 Load Centers

A Load center is the starting point of the radial distribution of power to the loads. As a result, the load center typically incorporates a main bus tie breaker and multiple circuit breakers, one for each load or groups of loads. The main bus tie breaker provides a connection point between the bus rail and the load center that can be opened or closed. Multiple circuit breakers are attached to the bus rails within the load center. The combination of the bus tie circuit breaker and the individual load circuit breakers provide two separate lines of defense for

the distribution system, allowing the entire load center or individual loads to be isolated from the overall distribution system.

2.3.6 Power Conversion Equipment

Power conversion equipment is loosely defined as any equipment that receives a power signal and changes it in some way to produce either a different signal or a cleaner signal. There are four main classifications of power converters: AC to AC, AC to DC, DC to DC, and DC to AC.

AC to AC converters are used extensively on naval ship electrical distribution systems. The most common piece of equipment for AC to AC conversion is a transformer. However, this type of converter refers to any device that alters the voltage, frequency or quality of the AC waveform.

AC to DC converters are used on shipboard distribution systems, as well. The most common AC to DC converter is an active rectifier. An active rectifier converts small amounts of AC power to DC, with little to no wave distortion on the AC side, for use in battery charging and generator excitation voltage to name just two.

DC to DC converters are not as common as the other converters but are expected to play an increasing role in navy shipboard electrical distribution systems. This is particularly true if the navy continues down the path to eventually using a medium voltage DC electrical distribution system. Some typical DC to DC converters include step down (buck), step up (boost), half bridge, full bridge, and fly-back converters.

Like DC to DC converters, the DC to AC converter is less common than the other converters. However, with the push for integrated power systems (IPS) this technology is expected to grow steadily in terms of usage onboard ships. The most common application onboard ships are likely to be variable frequency electric motor drives. One of the primary reasons for using this type of converter is that the DC input can be converted to any AC frequency and voltage combination desired; furthermore, it can be done on an as-needed basis. This allows for direct manipulation of the motor speed in a relatively simple and straight forward manner.

As US Navy ships make the transition to IPS, discussed later in section 3.2, it is expected that the conversion equipment utilized in these ship designs will substantially increase in terms of total volume, area, weight, and complexity.

2.4 Electrical Distribution Operation

The Navy operates the shipboard electrical distribution plant in one of two operational configurations: split plant or parallel plant. Reference [3] governs the procedures required to operate the electrical generation and distribution system in either configuration.

The choice of which configuration to use is based on the circumstances and or environment that the ship is operating in. The final decision making authority resides with the commanding officer of the ship and is based on his years of experience and proven decision making ability. Both operational configurations have inherent benefits and drawbacks, discussed in the following sections.

2.4.1 Split Plant Operations

The phrase “split plant operation” refers to a configuration where the electrical generators are electrically isolated from each other, each powering their respective loads individually. This type of operation is normally used when a higher level of reliability is desired or required. This is because excessive current in the distribution system will only affect a single generator. The disadvantage of this configuration is that a generator casualty will result in a complete loss of power to a portion of the ship [2]. This is mitigated to some extent as a result of the implementation of ZEDS and the ability to automatically isolate and re-route power. Additionally, systems classified as vital are configured to receive power from more than one source through the ABT or SABT switch.

2.4.2 Parallel Plant Operations

Parallel configuration is achieved by connecting more than one online generator to a common bus. This is achieved by closing the BTBs in the switchboard for non ZEDS ships. For DDG 51 AC ZEDS ships, to run two generators in parallel, typically both XT breakers for the online

generators and possibly the LT breakers need to be closed. In this configuration any combination of two generators can be connected in parallel to share the ship's load. A third generator remains in standby in case one of the online generators fails. This configuration has two advantages: First, it provides for maximum power handling capability and secondly, it allows a single GTG to fail without interrupting power to the ship. One disadvantage is that when one GTG fails the load that it is carrying will have to be assumed by the surviving GTG. This can overload the remaining GTG and cause it to also fail. Another disadvantage is that if a casualty occurs in the system that may cause excessive current (i.e. Class "C" fire), both generators will be exposed to the fault current and potentially both generators could be pulled offline. The switchboards contain protective devices that are designed to mitigate this type of failure.

The act of paralleling a shipboard generator onto an active bus has inherent safety risks associated with it. As a result, some very specific requirements must be met: the frequency of both generators must be within ± 0.2 Hz; the voltage of both generators must be within $\pm 5\%$ of each other; and the phase angle between the two generators must be within 10 degrees of each other.

In order to ensure these conditions are met the Navy uses several devices to control and monitor the paralleling operation. Some of these systems are automated and others are manual. Automatic paralleling of the online generator is done by the aptly named automatic paralleling device (APD). The APD allows for completely hands free paralleling of generators; this is the preferred method when the option exists.

Manual paralleling is the least desirable method. The manual method involves an operator at a local control panel monitoring voltage and frequency of the generator being brought online. Then the operator uses the synchronizing lights and a synchroscope, discussed in the next two paragraphs, to determine if the generator being brought online meets the preset requirements. If the answer is yes, then the bus tie breakers are closed. If not, then the operator manually adjusts the voltage or frequency until the requirements are met.

The synchronizing lights are used when attempting to parallel a generator onto an active bus, to determine the phase difference between the two generators. Ideally the operator would close the bus tie breakers at the midpoint of darkness. This roughly corresponds to when both generators are perfectly in phase with each other.

The synchroscope is a meter that spins proportional to the phase difference of the bus and the generator being paralleled. When the phases are within 10 degrees of each other the synchroscope begins to slow down and stops when they are in sync.

The voltage and frequency are monitored separately and must be equal or within the limits specified earlier before paralleling.

2.5 DDG 51 Power Reliability and Load Shedding

The ability to maintain power in the advent of an electrical fault and or damage to the electrical distribution system is a key component of the US Navy electrical distribution system. The methodology employed to ensure reliability is two pronged and starts with classifying each load as vital, semi-vital, or non-vital.

2.5.1 Non-vital loads

Loads that can be immediately secured without adversely affecting ship operations, survivability, or life are classified as non-vital. Examples are hotel loads (heating and galley), ship avionics, ground support equipment shops, aircraft fueling systems, and refrigeration systems, to name a few [4].

2.5.2 Semi-Vital Loads

Loads important to the ship but that can be shut down or switched to the alternate bus in order to prevent power loss to that load are classified as semi-vital. Examples include aircraft and cargo elevators, deballasting compressors, assault systems, and some radar, communications, and seawater service pumps [4].

2.5.3 Vital Loads

Loads that affect the survivability of ship or life are classified as vital. Power to these loads and their associated control and support equipment are not intentionally interrupted as part of a load shedding scheme. Examples of vital loads are generators, boilers, close-in weapon systems, electronic countermeasures, medical and dental operating rooms, fire control radar, and primary air search radar [4].

With each load appropriately classified, they can be connected to the distribution system in a way that allows balance to be maintained during a load shed event. Classification in and of itself is not enough; sensing devices and logic circuits are needed to detect the appropriate trigger and initiate the load shedding event.

2.5.4 Load Shedding

Load shedding is the process by which non-vital loads are removed from the electrical distribution system in order to prevent the system from being overloaded. There are typically two load shed stages: the first stage involves securing non-vital equipment and the second stage involves securing semi-vital [4].

Load shedding events are initiated based on sensors at the generator switchboards that monitor real power. For example, if the generator load exceeds a preset percentage of the generator rating for a set period of time, then a load shedding event is initiated. If the system continues to be overloaded for a set time and power rating, then the next load shedding event occurs [4]. This continues until the system is restored or completely shut down.

The goal of the logic circuits that control the breakers in a load shedding event is to ensure the online generator does not get overloaded and inadvertently trip offline. This requires a rigorous and systematic methodology that maintains power to vital and semi-vital loads, reconfigures the distribution system to isolate faults, and protects the generators. It is believed that the current load shedding system onboard DDG 51 class ships is not as capable as it could

be and that the integration of the NILM with the MFM III may enhance the inherent capabilities of the existing load shedding systems.

3.0 Other Electrical Generation Plants and Distribution Systems

A brief introduction into some different plants is presented here to give the reader a glimpse of what other systems are currently being used on non-DDG 51 class ships as well as what the US Navy shipboard power systems are likely to look like in the future.

3.1 Hybrid Plants

Hybrid plants use multiple types of prime movers to provide propulsion power, most of which connect directly to the shaft through a reduction gear. However in some cases like Combined Diesel Electric and Gas turbine (CODLAG) an electric motor is connected to the shaft either directly or through a reduction gear. The electric propulsion motor is typically used for low speed operations in a hybrid electric plant and with the prime mover, for instance a gas turbine engine, is clutched in when higher speeds are needed.

Combined gas turbine electric and gas turbine (COGLAG) is similar to the CODLAG but with one or more gas turbine generators rather than diesel generators.

A hybrid all electric combined gas turbine electric and steam turbine electric (COGES) is a propulsion and power plant where the gas turbine engine exhaust is used to make steam for a steam turbine generator.

3.2 Integrated Power Systems

The Navy's focus on a comprehensive and detailed systems engineering approach to IPS, is facilitating rapid development of needed technologies with an eye toward sustainable products. The following text outlines the proposed benefits of this initiative and the focus areas specified as barriers to realizing these systems onboard US Navy ships.

Information in [7] specifies three electrical generation systems operating on one distribution framework or architecture. The three power generation systems are medium voltage alternating current (MVAC), high frequency alternating current (HFAC), and medium voltage direct current (MVDC). All of these systems will provide power to loads throughout the ship

over a ZEDS configured architecture. Each system has multiple benefits and drawbacks when compared to the legacy 60 Hz, 450 Volt, AC power generation and electrical distribution systems currently in use by the US Navy.

3.2.1 MVAC Systems

An MVAC system, 4-13.8 kVAC at 60 Hz, is expected to require no additional technology development since an MVAC system is already in operation. The only barrier to implementation for a shipboard system is the need to develop more robust rules and standards to ensure safety of personnel and equipment at the voltage levels of interest in MVAC systems [7].

3.2.2 HFAC systems

A notional HFAC system will operate at 4-13.8 kVAC and produce 200-400 Hz power. The following advantages to HFAC systems are summarized from [7].

1. Smaller & lighter transformers, because the cross sectional area of a transformers magnetic core is approximately inversely proportional to the frequency of operation. This translates to a core that is approximately $\frac{1}{4}$ of the weight of a 60 Hz transformer.
2. Harmonic filters can be minimized or possible even eliminated, because the propulsion motors would be employing 3 phase to multi-phase transformers.
3. Galvanic isolation between subsystems through the use of power dense transformers to isolate all loads from the HFAC high power bus.
4. Improved acoustic performance over 60 Hz. Operation. By operating at a higher frequency than 60 Hz. the acoustic absorption of noise from equipment (such as transformers) vibrating at the power system fundamental frequency is greater in seawater. Additionally, sound isolation of equipment is lighter and easier at higher frequencies.

The following difficulties and/or barriers to employment of HFAC systems onboard US Navy ships were summarized from the complete list of eleven in [7].

1. Operating in the frequency range of 200-400 Hz will require a large number of generator pole pairs if operating a standard 1800 rpm generator. Similarly, slower prime movers would require a speed increasing gear to operate at the desired frequency using a standard 4 pole generator.
2. Loads on a HFAC bus will likely behave as constant power loads with negative incremental impedances. As a result, careful design is required to ensure system stability.
3. Ground fault current is higher compared to 60 Hz operation since cables must be derated, the number of cables and the line to ground capacitance will increase above that of a 60 Hz. system, increasing the ground fault current.
4. Cabling and switchgear designed for 60 Hz operation will require derating. Preliminary studies have indicated the derating factor for operating consumer off the shelf (COTS) circuit breakers at 240 Hz. will be on the order of 0.70 [8].

3.2.3 MVDC Systems

The ultimate goal of the NGIPS roadmap is to achieve a MVDC, 6 kVDC, electrical generation and distribution system. The following advantages of MVDC systems are summarized from [7].

1. Since the bus is no longer tied to a specific frequency, generators can run at the prime movers optimum speed without the use of reduction or speed increasing gears.
2. The MVDC system is expected to have improved acoustic performance over MVAC and HFAC systems because there is not a common frequency of vibrating equipment. The acoustic signature will be broader with fewer tonals that can be observed.
3. The paralleling of generators in a DC distribution system only requires voltage matching. This is particularly useful, from a speed perspective, when auto reconfiguring the distribution system to isolate and re-route power around areas that have experienced an electrical fault.
4. Since DC systems have a higher power density a MVDC distribution system enables a higher level of power generation and distribution without increasing the required

weight, volume, or area. This is particularly useful for small, space and weight constrained, ships that are expected to carry future high power systems.

A few projected difficulties or obstacles that require attention in order to move MVDC distribution systems forward are summarized from [7] below.

1. Traditional fault detection and isolation techniques employed by conventional circuit breakers and based on fault current are not desirable for MVDC systems due to the difficulty in extinguishing DC arcs in the absence of a zero crossing.
2. Because all of the loads on a MVDC bus will likely behave as constant power loads with negative incremental impedances, careful design is required to ensure system stability.
3. A new standardized method of controlling how load sharing is accomplished between generators is required to be developed.
4. Power quality standards for MVDC systems will need to be developed. The standard that is developed will have an impact on the size, weight, and cost for both rectifiers and the loads. As a result, it will be important to establishing standards that optimize the total system performance and cost across the range of ship applications.

3.3 IPS Justification

The one premise behind the desire to move to an IPS configuration onboard ships is based on the idea that current ship designs are not optimized to the maximum extent possible. Simply put the propulsion system and power generation system are two distinct and different systems onboard US Navy ships. The propulsion system is designed to meet the full power demands associated with the desired maximum speed of the ship and the electrical power generation systems are designed to meet the highest electrical load envisioned for the ship design. Both of these designs are also increased to account for growth and expansion, commonly called margin. The main problem being that ships are rarely operated at the peak demand levels that are the basis for their designs. The following section will attempt to explain the ramifications related to this lack of an optimized design methodology, which is directly related to non-IPS ships.

Historically across all shipboard platforms, approximately 90% of all installed power has been directly coupled to the propulsion shafting. In DDG 51 the four Allison GTMs combine to provide 75 Megawatts (MW) of power at a .8 power factor compared to the combined total possible electrical output to the ship service electrical load of 7.5MW. Looking at the projected and actual operational profile for DDG 51 class ships in Figure 11 and Figure 12 respectively, it is easy to see that the majority of the time, ships operate at less than 15 knots.

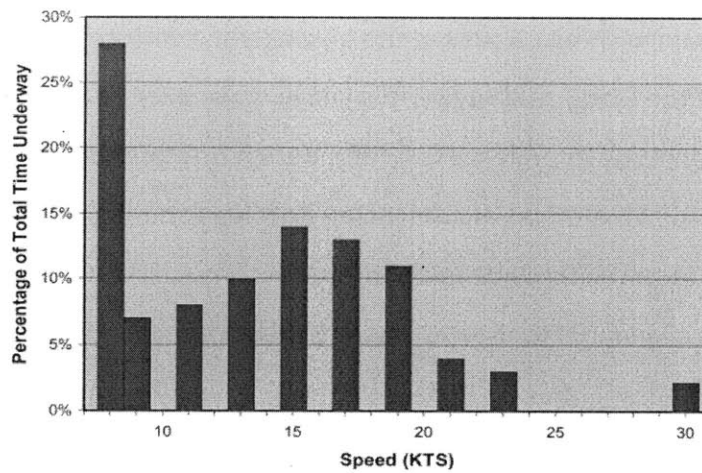

Figure 11: NAVSEA Operating Speed Profile for DDG 51 (NAVSEA 2002)

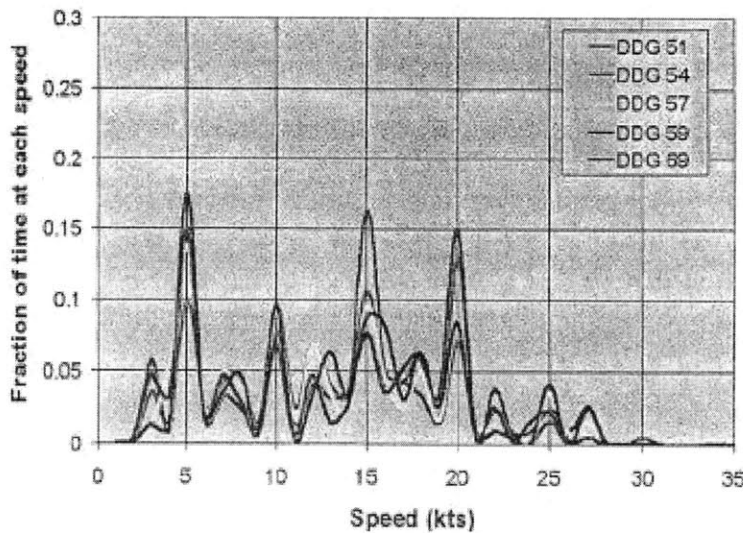
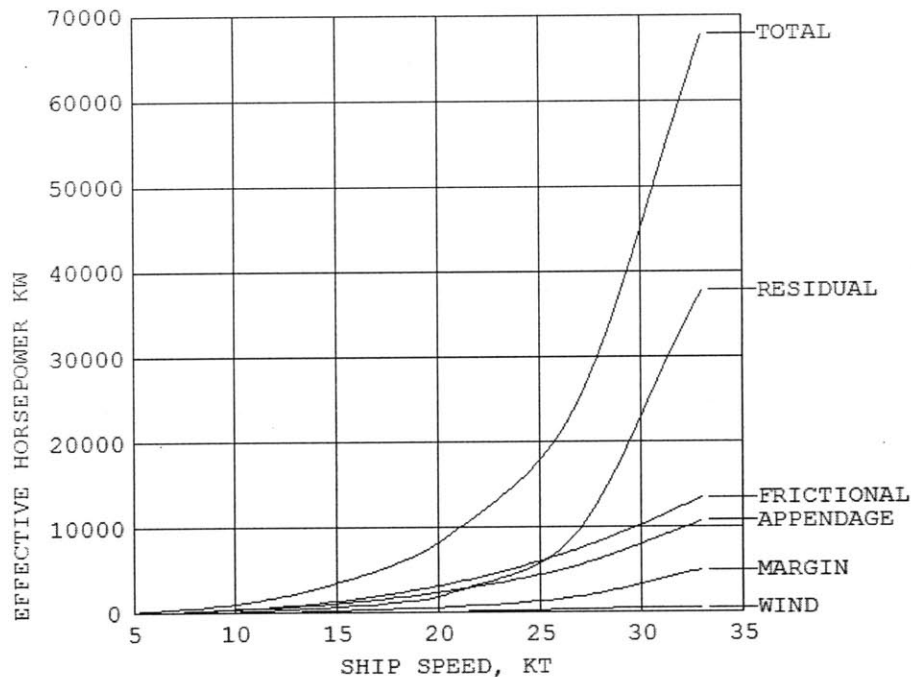

Figure 12: DDG 51 Individual 1998 Yearly Underway Speed Profiles (Rodeghiero et al. 1999)

The fact that a ship operates well below its maximum speed most of the time is not a major issue in and of itself. However, looking at how the non-IPS propulsion system is designed will provide insight into the negative aspects of a traditionally designed propulsion systems.

One of the first ship design parameters to be established with specific goal and threshold value is the sustained speed (max speed) of a ship. With the sustained speed goal and threshold values established the propulsion system is then designed to meet the goal if possible or at a minimum the threshold value. This inevitably leads to a situation where the major constraint on the actual sustained speed a ship can attain is based the amount of money the Navy is willing to spend to achieve the specified goal. The major problem being that the system is not optimized for “normal” operations, depicted in Figure 12, since the propulsion system is a standalone entity that is sized to meet the maximum power demand. Additionally [9] indicates that the data in Figure 12 is representative of most if not all ship classes, not just the DDG 51 class, that the data is based on.

However, to look at this information in terms of how it pertains to the use of IPS, a little more information should be provided. An understanding of the relationship between propulsion power and speed provides the needed insight. Figure 13, produced by Advanced Surface Ship Evaluation Tool (ASSET), based on a pre-loaded DDG 51 ship model, is a good example a typical DDG sized ships’ speed to power relationship.



DISPLACEMENT = 9145 MTON

Figure 13: EHP versus Speed Data from a notional DDG 51 ship hull in ASSET

Using Figure 12 and Figure 13 allow for some useful observations to be developed, namely that 98% of the time the ship is operating at 25kts or less. This corresponds to roughly 18 MW or less which in turn equates to approximately 26.7% or less of the total installed propulsion power of DDG 51. The remaining approximately 2% of the time the ship operates at speeds greater than 25kts requires the remaining 73.3% of the total propulsion power. This information shows how the current process could lead to an over sized propulsion system that utilizes much more fuel than it should and operates at a low efficiency most of the time.

This information could, on the other hand, enable the ship to be designed to operate at higher efficiencies most of the time and save significant amounts of fuel. Using the information shown in Figure 12 and Figure 13 a ship designer has the ability to optimize the power plant to meet the expected demand. This could be done in an IPS ship by designing the power capacity to meet all ship service loads and targeted propulsion loads based on the speeds the ship operates at, most of the time. Information of this sort can be determined by developing and using

graphs like that shown in Figure 12. Looking at DDG 51 which uses gas turbine engines this could translate to huge fuel savings since gas turbine generators are very inefficient when lightly loaded.

3.4 Relevance of IPS

Although IPS ships already exist, there is a significant amount of work in regard to developing better supporting systems to control, automate, and monitor an IPS ship. In order to progress research in this area, a means for testing prototypes is a fundamental requirement. Testing prototypes onboard ships under full load conditions is neither safe nor practical. A scaled down version of the real system is of significant practical use in the early stage design to test out the theory before spending significant amounts of money on full scale designs. The AC and DC ZEDS benchtop emulator boards built for this thesis, provide a robust and easy to access testing platform to meet that need.

4.0 Background Work

The following information is taken in part from two separate student thesis papers. This information is presented here to provide a detailed explanation of what has already been accomplished and how each part works together to form a single system that emulates shipboard generation and distribution of power.

4.1 Non-Intrusive Load Monitoring Overview

The NILM device has been under development at LEES for over two decades. This section will provide a brief overview of a current NILM version that was used during the development of this thesis. The purpose of providing this information is based on the fact that the NILM will be the primary component utilized in any near term product development and testing involving the AC or DC ZEDS benchtop emulator boards built for this thesis.

The NILM is a device that measures up to three voltage differences (either line to line or line to neutral), and up to three line currents with transducers at one or more points in an electrical system. These measurements can be used to calculate both real and reactive power envelopes as well as harmonic frequency content [10]. These measurements and associated calculated values can then be used for power monitoring throughout the distribution system.

The NILM can be broken down into three main components: Hall Effect current and voltage sensors, an input/output card, and a personal computer.

The Hall Effect is the production of a voltage difference (the Hall voltage) across an electrical conductor, transverse to an electric current in the conductor and a magnetic field perpendicular to the current [11].

4.1.1 Current Sensors

The NILM used for this thesis comes configured to operate with three LA 55-P current sensors. However, the nature of the testing conducted for this thesis required a current sensor that was able to measure substantially more current than the LA 55-P is rated for. As a result the LT 505-

S current sensor, also manufactured by LEM, was used for the short circuit test; described later in section 5.7.1 The Short Circuit Test.

4.2 The Hardware Model of a Shipboard Generator

Information in [12] depicts the electrical generation side of the hardware model of a shipboard electrical system. The intent of [12] was to build a hardware model of a shipboard generator, specifically a DDG 51 class Allison 501-K34 GTG. Additional work included development of MATLAB SIMULINK models of both of a DDG 51 shipboard generator and the hardware model. For brevity only the sections of his thesis that are still in use are presented here in detail. The final product of [12] is shown in Figure 14.

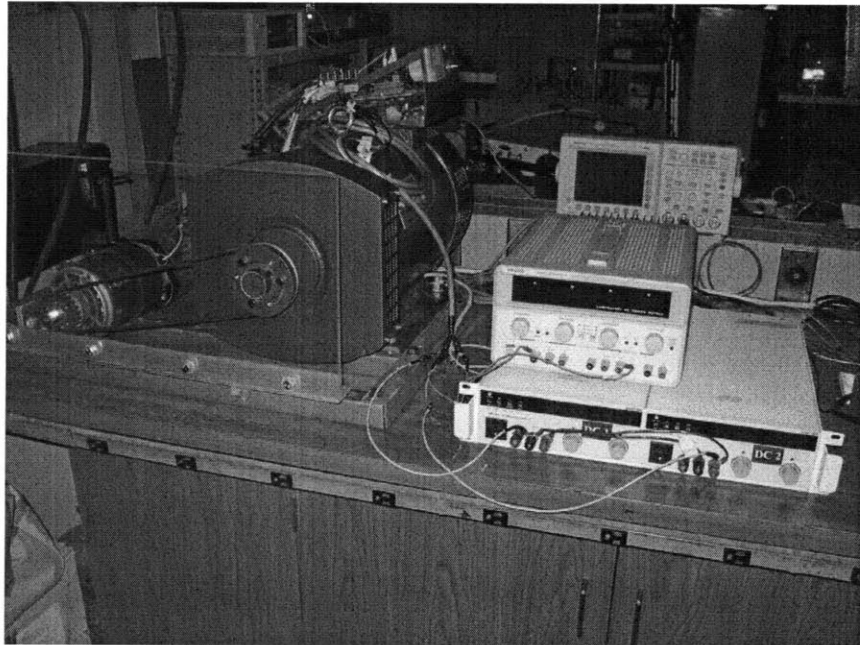

Figure 14: Hardware Model of a Shipboard Generator, MIT LEES, 2009

4.2.1 The Generator

The STC-5 generator was manufactured by Fujian Mindong Electric Manufacturing Co., Ltd. The name plate data from the actual generator is pictured below in Figure 15. In this case the generator was modified from being self excited to using a DC power supply to excite the field

windings. The generator operational parameters listed in, Table 2, are based on the 5 kW base power rating [12].

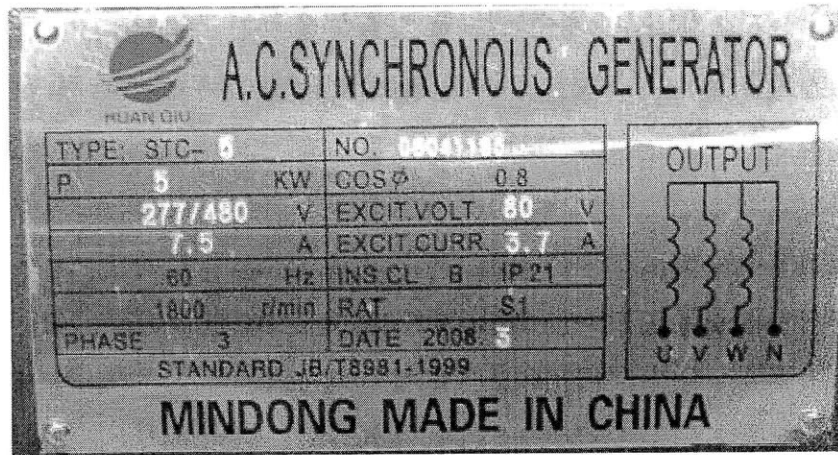

Figure 15: Mindong STC-5 Generator Name Plate [12]

Table 2: Generator Data Comparison

	Name Plate	Desire Operation
Frequency (Hz)	60	60
Voltage (V)	480/270	210/120
Current (A)	7.5	41.4

4.2.2 The Prime Mover

Two LEESON direct current permanent magnet motors were rigidly coupled together as shown in Figure 16, to act as the generator prime mover. Each of these motors is rated to produce 2 horsepower at 4800 rpm when provided 120 volts at 14 Amperes as shown in Figure 17, the name plate for these motors. By connecting them in series, electrically and mechanically, the two motors work together to produce a maximum of 4 HP at the rated speed if driven at rated capacity, if provided 240 volts and 14 amperes.

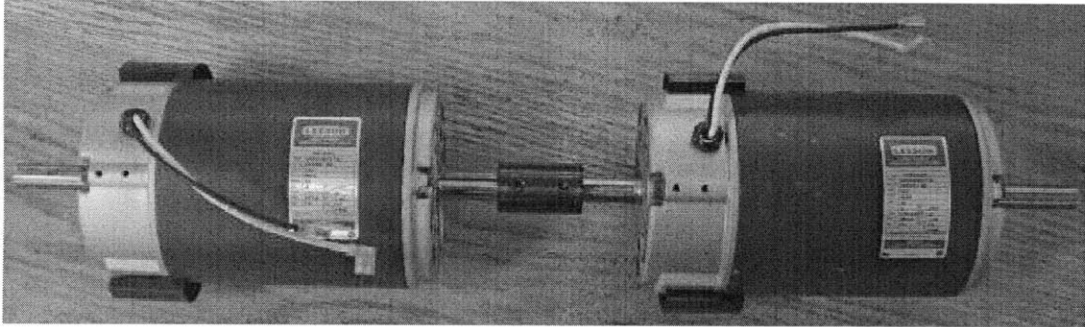

Figure 16: DC Motor Configuration

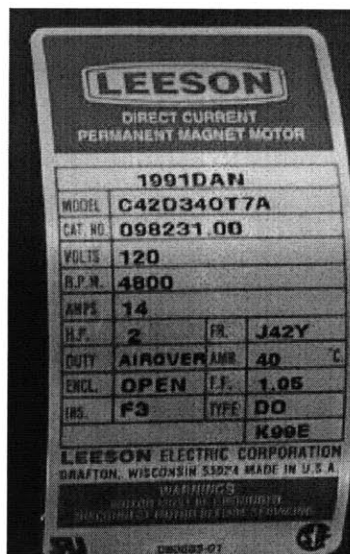

Figure 17: DC Motor Name Plate

The DC motors were tested in [12] and found to have the characteristics listed below in Table 3:

Table 3: DC Permanent Magnet Motor Characteristics [12]

	DC Motor 1	DC Motor 2
Motor Constant (K) in volts/(radians/sec)	.215	.217
Motor Resistance (R_M) in ohms	0.957	0.912

4.2.3 Input/output K-8061 USB Board

The K-8061 USB board allows for up to 8 digital and 8 analog input/output connections to send and receive data to the computer. This card is the primary means of communicating to the DC power supplies in order to control the DC power supplies which in turn control the speed of rotation of the DC motors/generator (frequency of the generator output) and the power to the field windings (voltage of the generator output). This USB board pictured in Figure 18, has the following features [13]:

- (8) analog 10 bit resolution inputs: 0-5 or 10VDC/20k ohm
- (8) analog 8 bit resolution outputs: 0-5 or 10VDC/47 ohm
- (8) digital inputs: open collector compatible (connection to GND=0) with on board LED indication
- (8) digital open collector outputs (max.50V/100mA) with on board LED indication
- (1) 10 bit PWM output: 0 -100% open collector output (max 100mA/40V) no board LED indication
- Response time: 4ms per command
- USB Port: 2.0 and 1.1 compatible

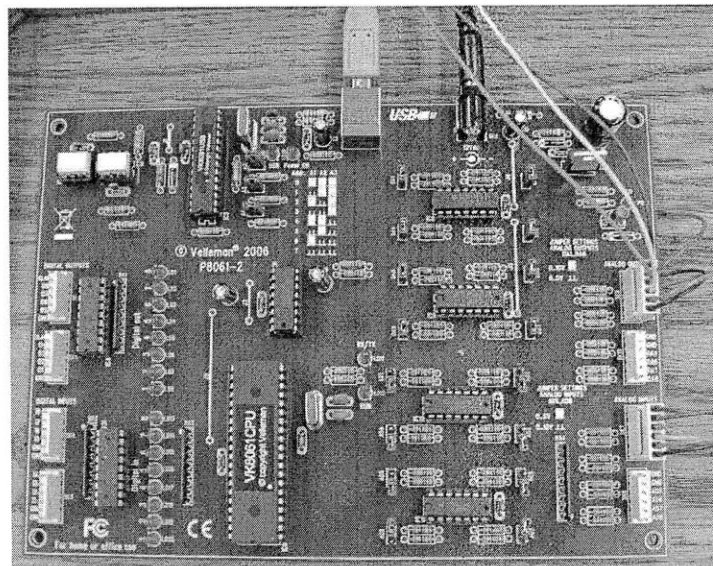

Figure 18: K-8061 USB Board

The USB board allows for an easy method of transferring data to and from the computer; however there are several noted limitations one in particular is the 8 bit DC output. This causes a loss of fidelity when attempting to control the power supply, relegating fine tuning to a future goal in [12].

4.2.4 Hardware Model of a Shipboard Generator Conclusions

Based on [12], significant work remains to achieve a true hardware scale model of an Allison 501-K34 GTG. However, a “true” scale model is not needed and the current STC-5 generator is sufficient for providing the electrical power to the AC and DC ZEDS developed for this thesis.

In order to improve on the hardware model of a shipboard generator the frequency output to the user should be based on the actual generator output. The current method using the sprocket and Hall Effect sensor has a degree of variation on the order of $\pm 3-5$ Hz. This variation of $\pm 3-5$ Hz is well above the maximum allowable frequency deviation for operating a generator, around ± 1.2 Hz and is well over the ± 0.2 Hz allowed when paralleling two generators.

Readings taken for this thesis indicate that the frequency of the generators output is much more consistent than the existing current sensor. This change could be accomplished by using a separate LabJack, individually powered and connected to the personal computer, and a single HTR 50-SB sensor on one phase of the output of each generator. Since the output of the HTR 50-SB is a voltage signal this can be fed directly into to the computer where it could easily be manipulated to produce a near real time frequency output. The clear advantage is the reduction in EMI related issues and a relatively straight forward and more stable means of determining frequency.

4.3 Modeling for Ship Power System Emulation

The main objective of [10] was to determine the motor constants of the 5 kW generators discussed in [12], the results of [10] are listed in Table 4. In addition to determining these characteristics two numerical models were developed, one of the DDG 51 electrical generator and the other of the STC-5 generator. After tuning these models to actual data he was then able to conduct a general comparison between the DDG 51 and STC-5 generator. This provided

the necessary quantifiable validation of his assertion that, although not perfect, the STC-5 characteristics were sufficient for conducting lab experiments. The primary justification for the belief that this system is suitable as a lab test bench is based on the rise time of the fault current. Since the STC-5 generator rise time is faster than that experienced by the DDG 51 electrical generator, any system proven to work on a notional distribution board powered by this generator will be faster than required on the DDG 51 electrical distribution system.

Table 4: STC-5 Generator Characteristics from Testing [10]

Armature Resistance (R_1)	.72 Ω
Average Field Resistance (R_F)	15.8 Ω
Change in Field Current (A_X)	.0023
Exponential Shape of the Field Current (B_X)	.0276
Slope of the Air Gap Line (K_{AG})	165
The value of reactance corresponding to rated armature current (X_d)	8.7 Ω
The transient short circuit d-axis time constant (T'_d)	45ms
The transient d-axis reactance (X'_d)	.197 Ω
Sub transient short circuit d-axis time constant (T''_d)	15ms
Sub transient d-axis reactance(X''_d)	.094 Ω

5.0 The ZEDS Hardware Model Architecture

Development of the AC ZEDS hardware model of a shipboard electrical distribution system followed an atypical systems engineering process. One of the more common ways of depicting this process is called the product waterfall, shown below in Figure 19.

For the purpose of this section the “client” or “customer” refers to the collection of workers at MIT’s LEES.

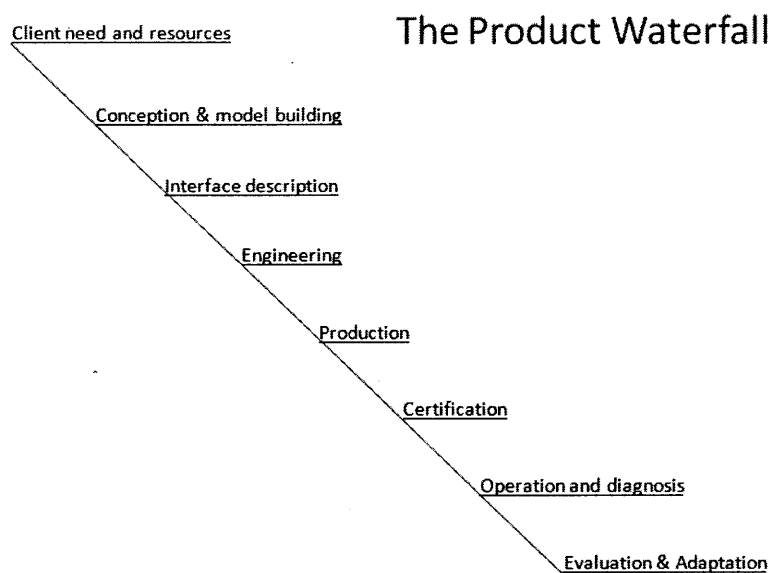

Figure 19: The Product Waterfall [14]

5.1 Client Need and Resources

In this case, the client found a shortfall in lab capability, over time, in regard to the ability to easily test proposed shipboard experimental research equipment. The characteristics of a shipboard electrical environment were found to be significantly different from a non-shipboard electrical environment further complicating testing; a few of these differences are listed below:

1. A Ring Bus with radial distribution with versus a solely radial distribution
2. A “no ground” electrical distribution system

3. Fault isolation equipment
4. Loading characteristics

As a result the testing of equipment designed for use onboard ships was often difficult to accomplish in the lab setting. This led to equipment often being tested for the first time in use onboard the ship with little if any practical lab testing. When lab testing was performed the equipment would often perform differently and or exhibited unexpected characteristics when tested onboard the ship.

The unfortunate consequence was lost time, difficulty in troubleshooting and isolating faults in the equipment being tested and increased skepticism from the customer, in this case the United States Coast Guard (USCG) or the United States Navy (USN) personnel.

An additional issue specific to the USN and to some extent the USCG has to do with new product development, testing, and employment on ships. After years of “loose” control, the US Navy realized that planned and unplanned modifications to their ships was costing a lot of money and creating difficulties in regard to repairs and supply chain management. As a result, a much more rigid process was put in place to ensure a measure of uniformity and system level continuity across classes of ships. This process requires a significantly higher level of product maturity than may have been required in the past. It should be noted that a method does exist to push a system through the process quickly. When a product is needed or otherwise deemed appropriate to take on the increased cost or risk. However, these cases are very rare.

The outcome of these changes being that a product must be well documented in terms of robustness and capability, in a shipboard environment, before it can be installed on a USN ship. As a result this is another area where a hardware model of a shipboard electrical distribution system may be leveraged to move research from the lab onto USN ships.

5.2 Conception and Model Building

In order to meet the customer needs and expectations several variants of AC and DC electrical distribution systems were developed and provided to the customer for input and evaluation

regarding desirable traits and undesirable traits. Through several iterations, which might also be called development spirals, the following basic architectures shown in Figures 1 and 2 previously and reproduced below in Figure 20 and Figure 21, were selected.

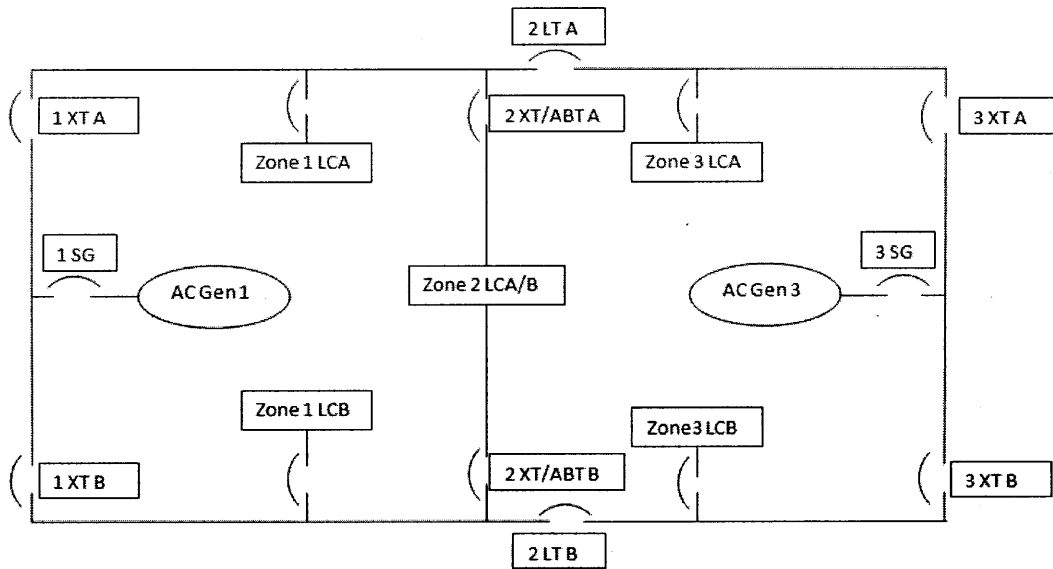

Figure 20: AC ZEDS Hardware Model Concept

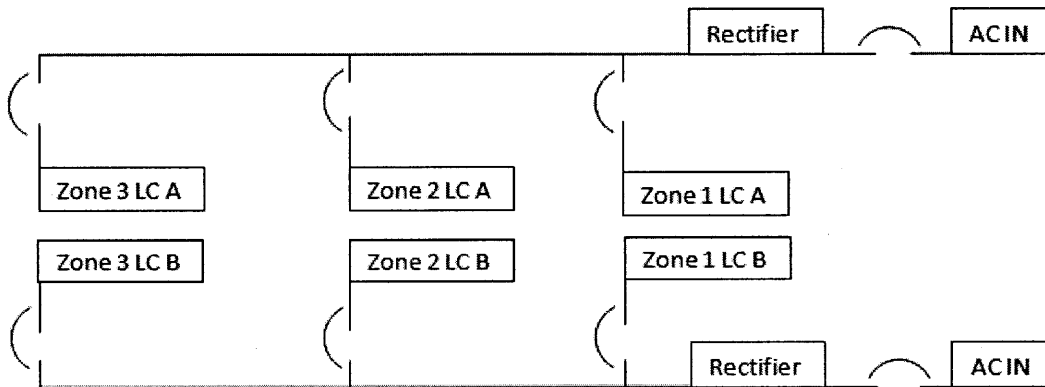

Figure 21: DC ZEDS Hardware Model Concept

LEGEND: Circuit Breaker

LC = Load Center XT = Cross Tie Breaker LT = Longitudinal Tie Breaker SG = Generator Breaker

The chosen AC ZEDS architecture compares favorably with the existing, basic 60Hz electrical distribution architecture onboard DDG 51 class ships, hull numbers 91 and greater, shown in Figure 3 originally but reproduced here as Figure 22.

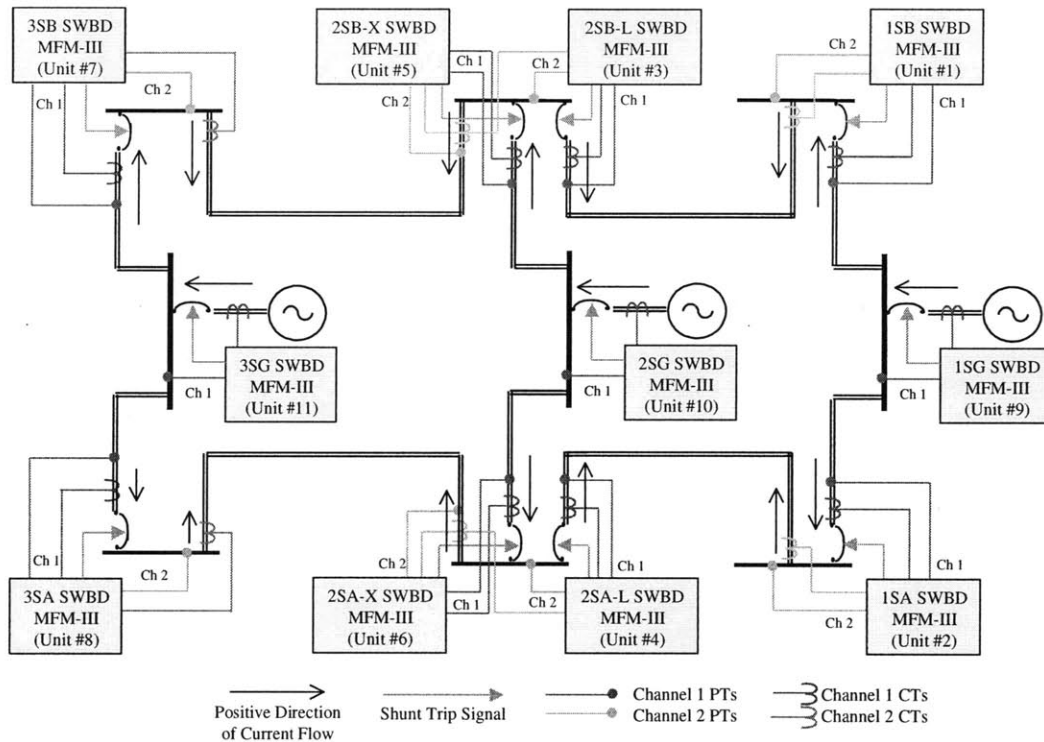

Figure 22: MFM-III addressing, locations, and signal inputs for DDG91+ [1]

Additional work done to model the system is provided in Appendix V and includes a depiction of the system architecture at a high level, 3-D and 2-D representation of the combined generator and distribution system benchtop emulator, a detailed systems architecture, and circuit diagrams.

5.3 Component Level Analysis of Alternatives

The design process included an analysis of component choice for the ZEDS hardware model. Although this phase of the design process is not specifically called out in the Product Waterfall depicted earlier, it was deemed an important enough function to provide a separate section of discussion. The logical order of either doing a component level analysis of available alternatives

or identifying/describing an interface methodology depends on the product being developed. In this case specifying the interface to be used might result in the limiting the available component list to just a few items or potentially removing all available components from consideration. This could result in the need for a custom part, which is very costly in most cases. As a result the component level analysis of alternatives was conducted first, followed by the interface decisions. In order to complete a component level analysis of alternatives some benchmarks are needed from which to rate the available components, as well, as an understanding of the functionality/characteristics of the existing, in this case, full scale system used onboard USCG and USN ships.

Using information available in online training guides and provided by sponsors several components were able to be evaluated for possible use on this system, the components and the criteria used to select it are shown here. The circuit breakers and switches were evaluated on their speed of remote actuation, availability, and cost. The different NILM current sensors were looked at for ease of connectivity, availability, fidelity of measurement, and cost. Wire was sized and selected based on the ability to pass the potential fault current and availability. The connection and interface components were selected based on ease of use, availability, and cost.

Looking specifically at current sensors, as an example, face to face discussion/interviews with current and former lab personnel and the crew of the USCG Cutter Escanaba, indicated that a different current transducer might improve ease of use while maintaining functionality and sensor fidelity. The solid core sensor was initially chosen for the high quality operating characteristics however, the fact that it is a solid core component meant that the ships electrical equipment power lines needed to be physically disconnected from the bus in order to install the sensor. The act of disconnecting wires creates an obvious increase in personnel and equipment risk, in regard to safety, and made the crew of Escanaba somewhat uncomfortable with the overall installation, removal, and testing process. The most obvious solution to decrease risk and settle any nervousness associated with the installation, removal, and testing of equipment is to incorporate the use of a split core sensor. However finding a suitable split

core sensor that was affordable and met the design requirements set by the customer proved to be somewhat challenging. In the end a split core LEM sensor was selected and tested in the lab. The testing procedure and results are presented later in the section titled, 5.7.2 Current Sensors Alternative Testing/Comparison. This sensor is relatively expensive compared to the solid core transducer.

5.4 Interface Description

In order to develop a better understanding of how the existing system interconnected a connection matrix was developed, for the existing hardware model. Then to understand how the AC and DC distribution boards would interface with the components of the other systems they were added into the connection matrix, the final version is shown in Figure 23.

With a better understanding of how the boards would interface with the existing hardware model, the interface descriptions were then developed. The primary focus of the customer in regard to interfaces for the hardware model was commonality and availability. At the load and source interfaces on the board the customer specified that no tool should be necessary to disconnect and connect the source/loads. Additionally the customer specified that the switches or circuit breakers, used to emulate the XT, LT and SG circuit breakers, should have interfaces that support placement of the current sensors and the voltage leads for the NILM box. Lastly the customer required that the switches/circuit breakers on the hardware model be able to interface with a computer to remotely open/close the switch or circuit breakers at the locations shown in Figure 22.

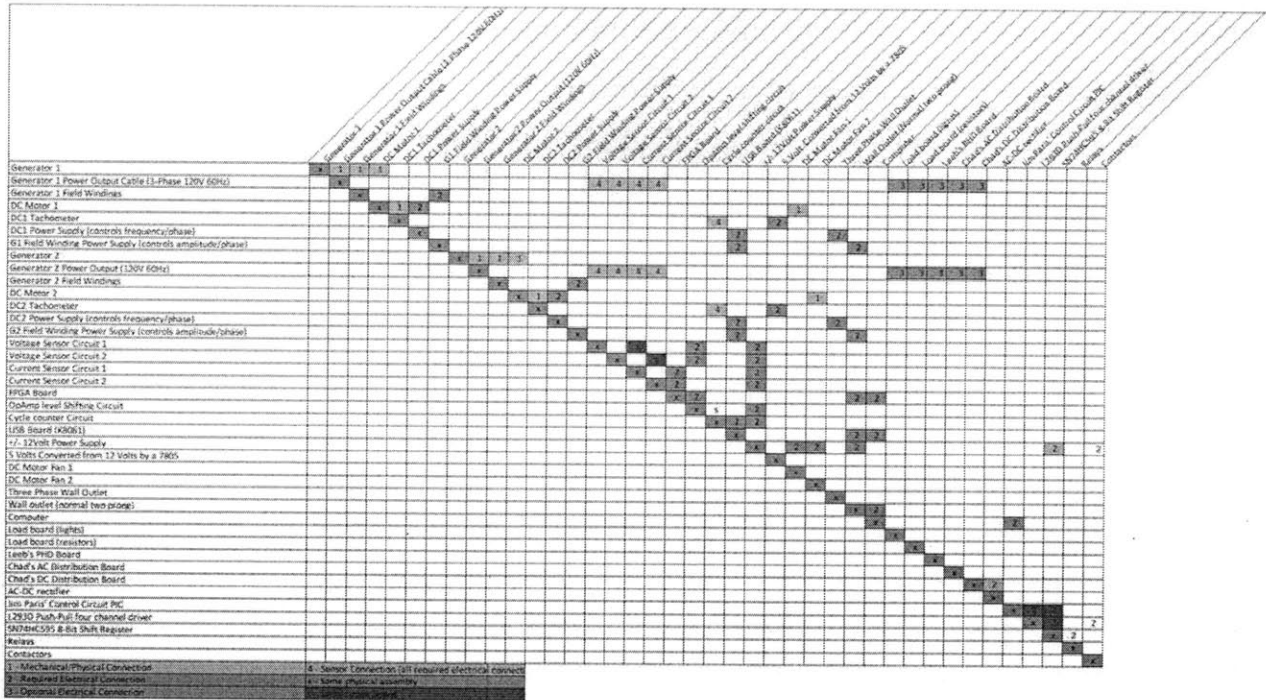

Figure 23: AC ZEDS Hardware Model Connection Matrix

Using this information common electrical receptacles and connectors were selected. The items selected, cooper L15-20 plugs and receptacles pictured in Figure 24, did not require an additional tool and met all other criteria. Additionally at each circuit breaker easy quick disconnect, fasteners were used.



Figure 24: Source and Load Plugs and Receptacles [15]

5.5 Engineering

With interface design worked out the next task at hand was to engineer a reasonably robust system. This included sizing equipment to handle not just the normal electrical load but also

the possible fault current. The first step in determining the expected fault current involved conducting a short circuit test, described below in 5.7 Testing/Certification. The results of the short circuit test allowed for component selections that ensured the safe operation of the system even during fault conditions. This was deemed particularly important as the benchtop emulator is expected to be short circuited routinely to test out various research projects at LEES.

5.6 Production

Production of the AC and DC ZEDS was fairly straight forward. Utilizing the concept drawings the boards were marked for basic layout and placement to ensure adequate spacing. Then the components were fastened to the board using wood screws. Next each component was wired up. For the bus lines, individually color coded spools of wire were not available in the lab, so this wire was extracted from sheathed cable lengths. This was a fairly time consuming and strenuous task; however, the desire to have a consistent color coding scheme and the ability to easily verify proper connections made the level of effort required more than acceptable.

In regard to the power connections, since this is a model of a shipboard system that has no true ground, a four bladed plug was chosen with the grounding blade being used to pass the neutral line. Additionally, all of the plugs and receptacles were wired with the following convention:

1. X-Terminal to Red wire
2. Y-Terminal to White wire
3. Z-Terminal to Black wire
4. Ground Terminal to grey wire with white marking/stripe*

*Note that the receptacle in the center of the board is a five bladed plug for use with the hardware model of a home electrical distribution system, built by Professor Steven B. Leeb. That receptacle is wired as noted above but the earth ground (green wire) is connected to the grounding blade receptacle and the neutral blade is connected to the neutral receptacle. When using this plug, the earth ground should be attached to an appropriate grounding point.

5.7 Testing/Certification

5.7.1 The Short Circuit Test

The short circuit test was conducted to determine the maximum fault current the board would experience based on the current generator and prime mover combination.

The short circuit test configuration included the current hardware model configuration for the shipboard generator, three SAP 4840D Solid State Relays (SSR)s, a DC power supply to drive the (SSR), a timer circuit to control the DC power supply to the SSRs, a NILM Box configured to read line to line voltage.

With the timer circuit set up in a monostable configuration with an appropriate sized resistor and capacitor value to achieve a $\sim 50\text{ms}$ single shot. The output of the 555 chip, pin 3, was run to the positive terminal of the solid state relay (SSR) and the negative terminal was run back to ground. The three SSRs were connected in parallel so that they all operated simultaneously. Each phase of the generator output was connected to one terminal of the load side of the SSRs and the other terminals were all wired together. A basic schematic for the setup is shown below in Figure 25.

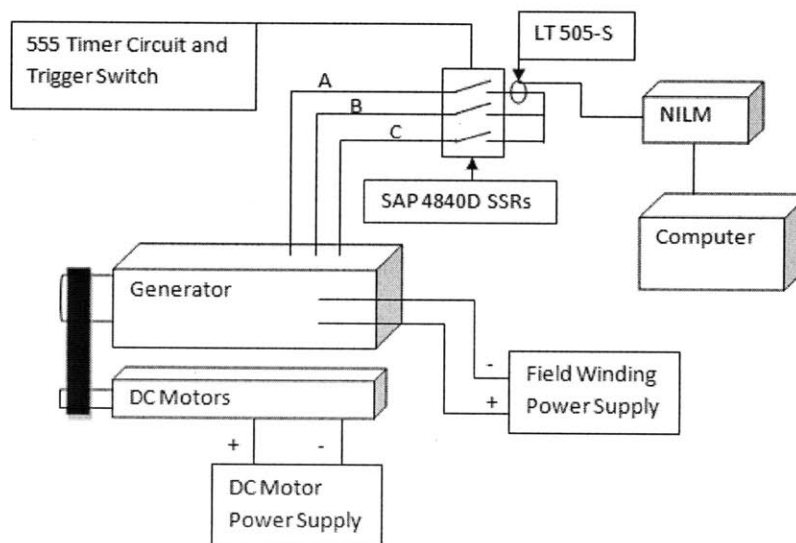

Figure 25: Short Circuit Test Configuration

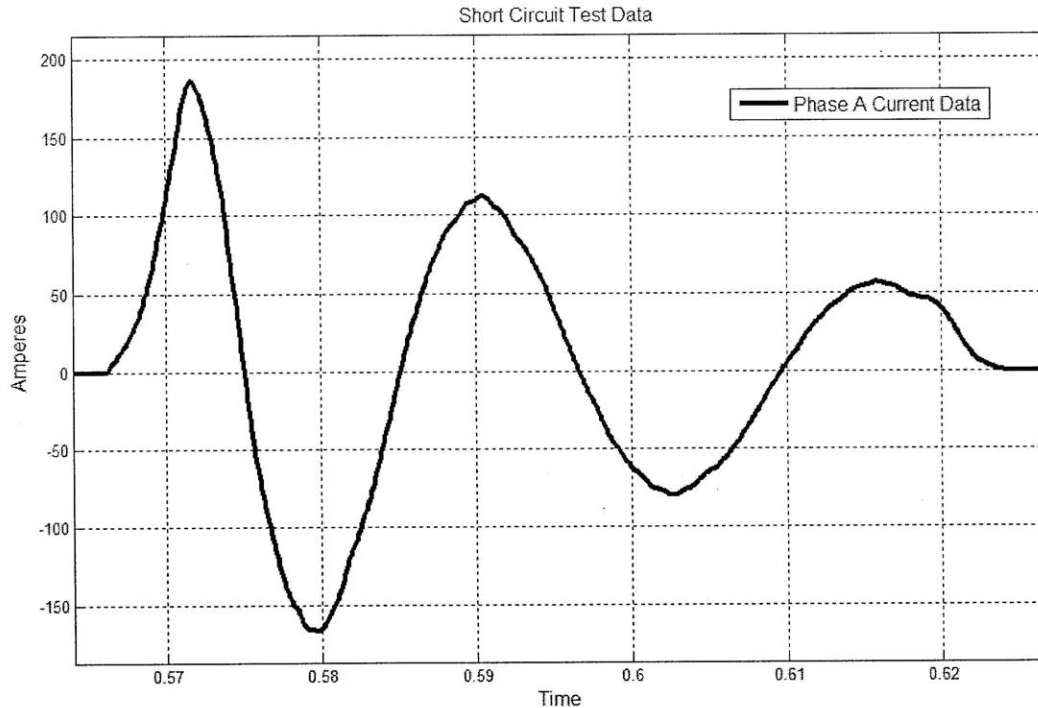

Figure 26: Short Circuit Test Data

The test results are plotted in Figure 26; the odd curvature that initially develops in the wave form has not been diagnosed but may be a result of rapid deceleration of the generator or from the sensor itself. The maximum short circuit current achieved, at the rated 3.7 Amperes excitation current, is 185.8 Amperes. Having this information allows the various components of the system to be sized appropriately to ensure functionality and the ability for the hardware model to withstand the rigors of acting as a lab test apparatus.

5.7.2 Current Sensors Alternative Testing/Comparison

In order to increase the ease of installing the current sensor onboard the ship, discussed earlier in 5.3, the best suited replacement for the LA 55-P, shown in Figure 27, was determined to be the HTR 50-SB, shown in Figure 28.



Figure 27: LA 55-P Transducer [16]

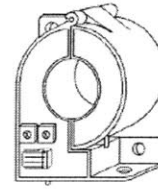

Figure 28: HTR 50-SB Transducer [16]

The HTR series current transducer is based on the same general principal, the Hall Effect. This sensor provided the closest match between specifications when compared to the LA 55-P. Table 5 shows a side by side comparison, taken directly from their datasheets.

Table 5: LA 55-P and HTR 50-SB Comparison Chart

	LA 55-P	HTR 50-SB
Primary Nominal RMS current	50 Amperes	50 Amperes
Primary Current Measuring Range	± 70 Amperes	± 100 Amperes
Accuracy at $\pm 12V$	$\pm .9\%$	$\leq \pm 2\%$
Linearity Error (excluding electrical offset)	$< .15\%$	$\leq \pm 1\%$
Response time to 90% of I_{PN} step	$< 1\mu s$	$< 10\mu s$
di/dt accurately followed	$> 200 A/\mu s$	$> 50 A/\mu s$
Frequency Bandwidth	DC ... 200 kHz	DC ... 10 kHz

The results of the testing, shown in Figure 29 and Figure 30, indicated that the HTR 50-SB has sufficient fidelity for this application, matching the LA 55-P sensor very closely.

However, the HTR 50-SB sensor is more expensive and there are many LA 55-P sensors in the lab. As a result the LA 55-P was used for the hardware model and testing in this thesis, with the exception of the comparison. However, due to the ease of use and desire to make the ship visits as palatable for the crews as possible, for future ship visits the HTR 50-SB sensors is expected to be used exclusively.

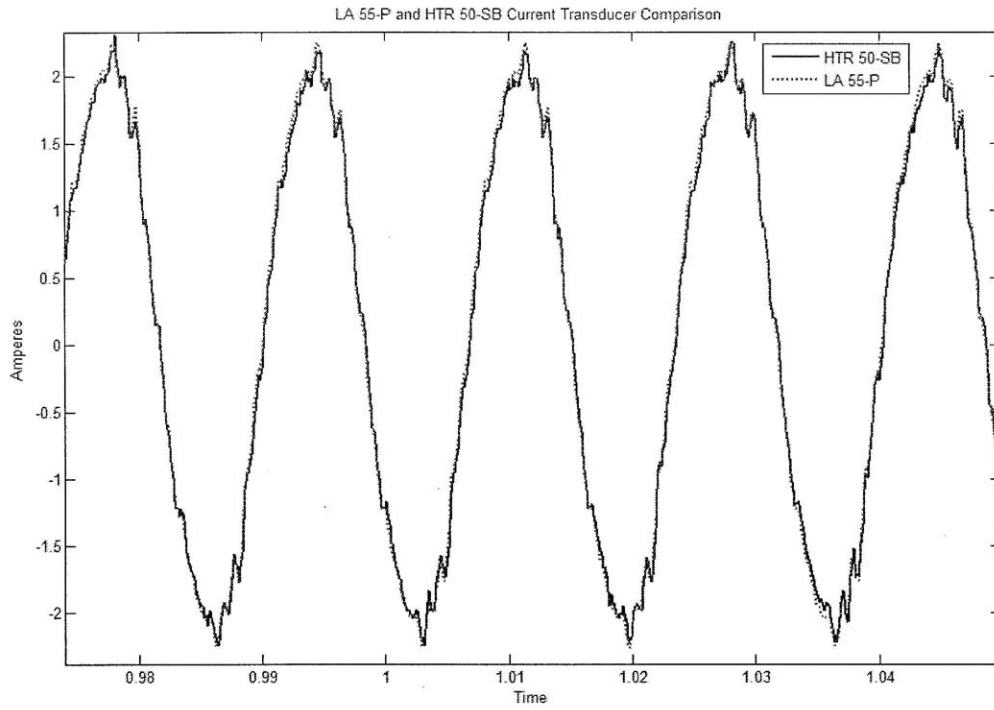

Figure 29: LA 55-P and HTR 50-SB Current Transducer Comparison

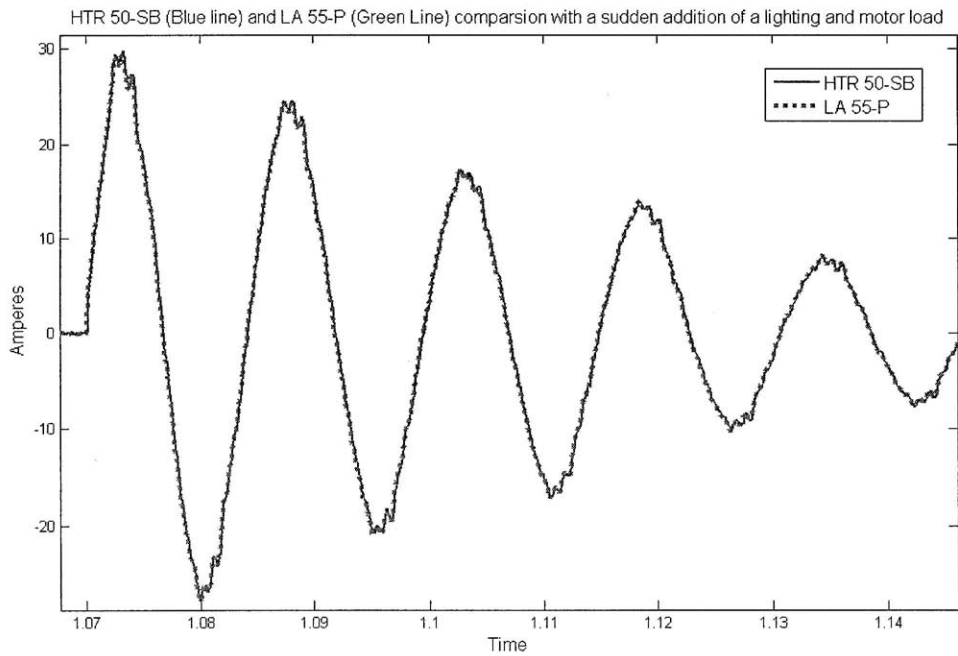

Figure 30: Transient Comparison of LA 55-P and HTR 50-SB

5.7.3 Solid State Relay and Solenoid Operated Contactor Comparison Testing

The next set of components compared and tested for use in this thesis were technologies to simulate the circuit breaker operation. Circuit breakers primarily function as safety devices to isolate high current faults and to protect personnel doing maintenance in home distribution systems. This is also true when they are used in shipboard distribution systems however, that is not all they do. The circuit breakers of particular interest to this thesis are the cross tie, longitudinal tie, and generator breakers. These breakers are used as safety devices but another key function is their ability to be automatically closed or opened manually or automatically. This added functionality allows for split second response times to isolate faults onboard ships and aids in the automatic paralleling of two generators on a common bus, both of which are of particular interest to researchers at MIT's LEES.

	SAP 4840D	P31E
Load Voltage	40-480 V _{RMS}	0-480 V _{RMS}
Min Sustained Load Current	.1 A _{RMS}	0 A _{RMS}
Max Sustained Load Current	40 A _{RMS}	40 A _{RMS}
Max Current (10ms)	400 A _{PK-PK}	700 A _{PK-PK} ²
Approx. turn Off/On time	½ cycle	3 cycles ³
Control Voltage	0-32 VDC	0-24 VDC
Min Control Op. Voltage	3 VDC	8 VDC
Control Amperes	5 mA	286 mA

Table 6: SAP 4840D SSR and P31E Contactor Data

Two primary candidates were found to be viable options in terms of their individual specifications, solid state relays (SSR), and solenoid operated contactors. A fairly extensive

² Estimated value based on dielectric breakdown rating of 2,200 volts and FLA rating of 40 amperes

³ Time determined by experiment using full rated control voltage.

search for suitable devices at a reasonable price resulted in the selection of the SAP 4840D SSR and the P31E contactor. Table 6 shows their basic characteristics side by side for comparison.

Being that both components had similar specifications, the SSR was initially chosen because of the faster response time. Testing in [10] indicated an approximate 6ms delay between signal receipt and opening of the circuit at the zero crossing. Testing of the P31E shows an approximately 50ms or three cycle lag between initiating a opening request and the actual opening of the circuit.

One of the primary reasons for building a hardware model of an electrical distribution system was to test out the NILM on a ring bus configured electrical distribution system and allow research in the areas of fault isolation and power flow monitoring. The key tenant is that power will flow to a load via multiple paths in a ring bus configuration. By using current and voltage sensing equipment, it is possible to quickly locate, in general terms, the fault point in the electrical distribution system and electrically isolate the fault. This is intended to minimize the effect that a fault has on the overall system and allow for re-direction of the power flow. This ability to re-direct power flow by reconfiguring the distribution system is a vital requirement for military applications. Since the premise behind any fault location algorithm on of the electrical distribution system is based on the ability to determine the flow of power in the system. The test setup used for this Section and Section 5.7.4 is depicted below in Figure 31.

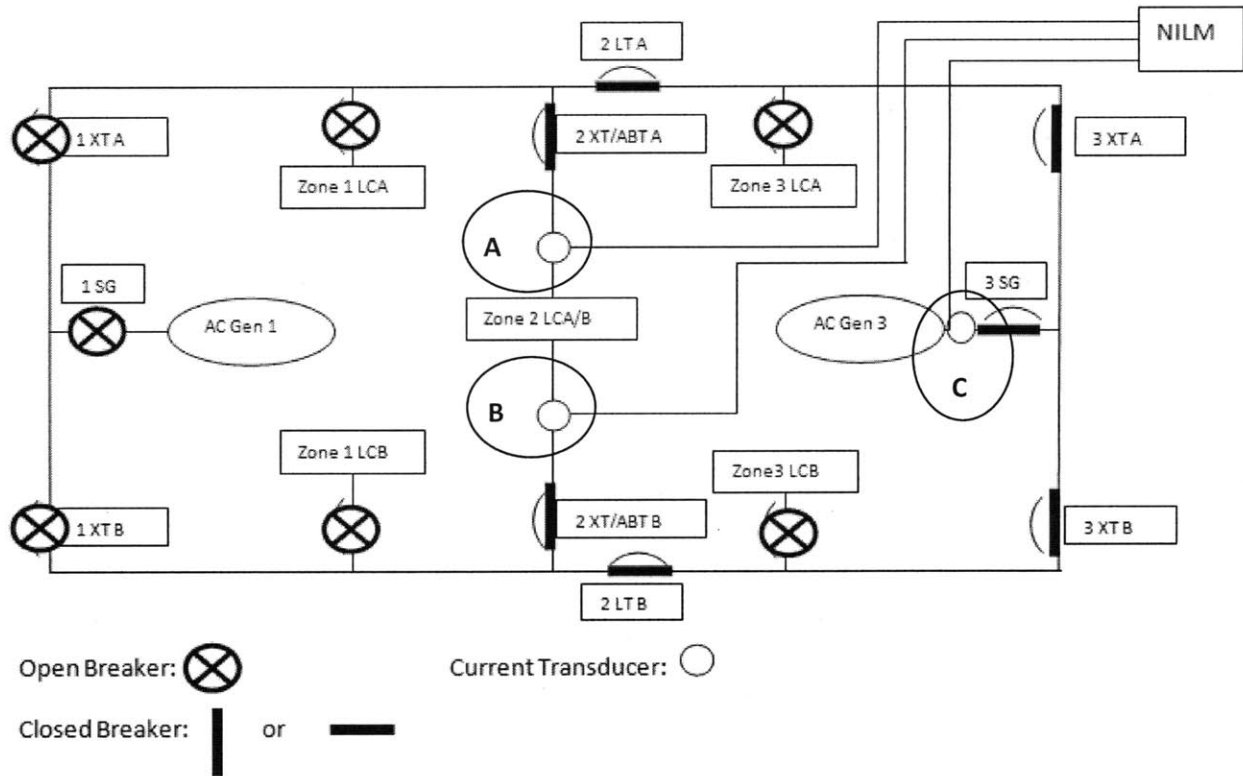

Figure 31: Aggregate Power Test Setup

- The current sensor labeled A is reading the bus current to the load on the left side of the load
- The current sensor labeled B is reading the bus current to the load on the right side of the load
- The current sensor labeled C is the sensor reading the current from the source to the bus.

Testing of the SSR showed an undesirable effect in regard to ring bus operation. After some additional investigation it was determined that the SSRs do not allow for the free flow of power throughout the distribution system. As it happens, they have a tendency to funnel power flow through one SSR. The cause of this action is based on the SSR operating characteristics. More specifically, the SSR has a minimum operating requirement of 0.1 amperes on the load side. As a result when the initial push of current happens on the bus a SSR on one side of the load will tend to close before the SSR on the other side of the load. When the first SSR closes the SSR on one side of the load is not able to reach the required current level to close it and all of the current passes through the single SSR. Each time the AC waveform goes through the zero crossing the same competition to close first happens. There is apparently some bias or an undetermined force acting to make one SSR close faster on the positive side and the other to close faster on the

negative side. As the system appears to reach a status quo of sorts bouncing back and forth between the two SSRs at each zero crossing after the current level reaches normal operating levels and stabilizes.

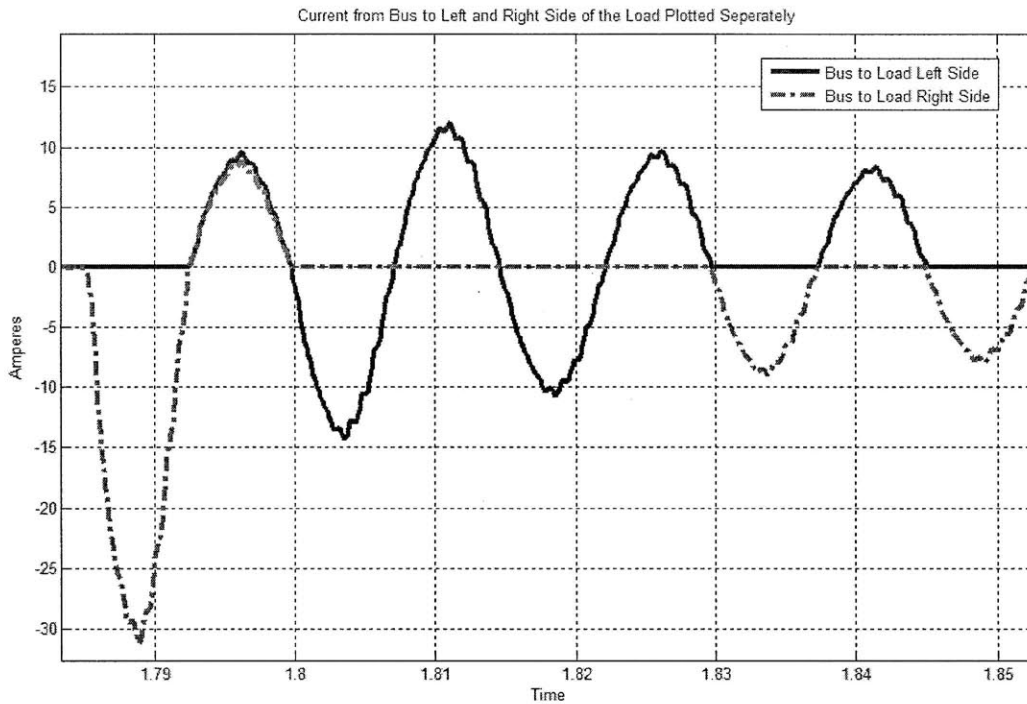

Figure 32: Current Flow to the Load Through the SSRs

To verify that the set up was physically correct the power flow data through the SSRs on the left and right side of the load were added together and plotted with the source to load current data in Figure 33. As expected the combined data does match the current flowing from the source to the bus verifying the setup was correct.

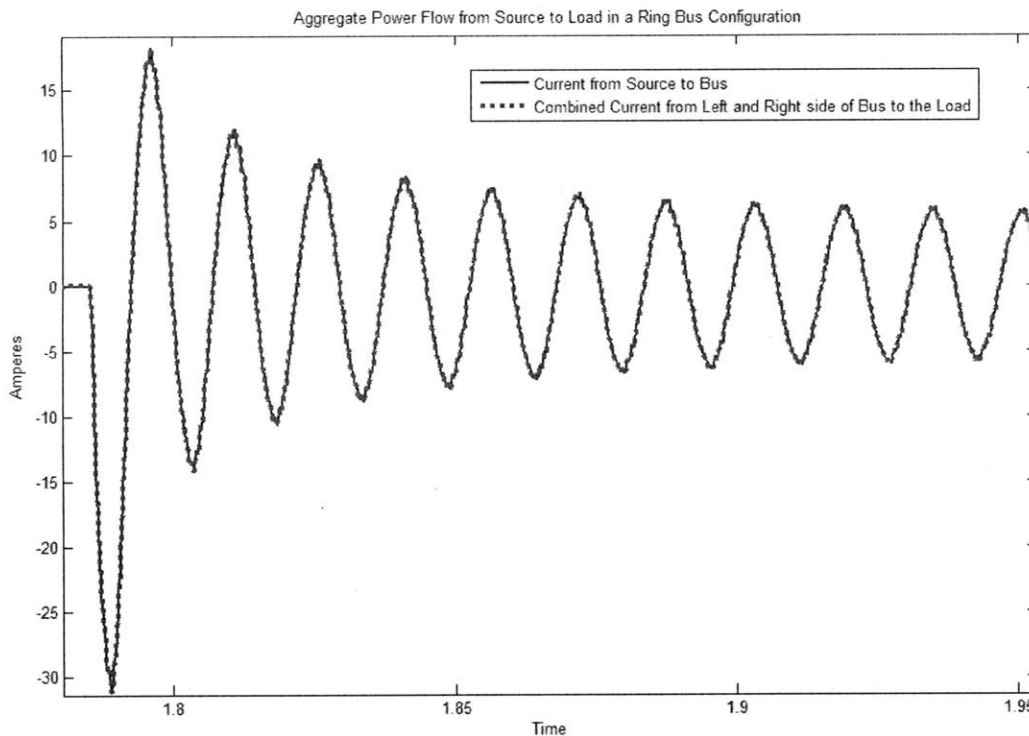

Figure 33: Aggregate Current Data Using Solid State Relays

Unfortunately the inability to pass current freely through both the A and B side of the AC ZEDS buses when configured in a ring bus makes the use of SSRs in this application undesirable. As a result, the P31E contactor was selected to operate as the ACB circuit breaker in the hardware model of the AC ZEDS. It is possible that a solution may be developed to allow the use of the SSRs; however, that task is beyond the scope of this thesis and will be left for future work.

5.7.4 NILM Power Monitoring on a Ring Bus Configured Distribution System

Using the P31E contactors in place of the circuit breakers, the hardware model of the AC ZEDS was successfully tested to verify the ability to monitor aggregate power across the system. This particular aspect is of vital importance to the usefulness of the system as a lab test bench for future research and experiments. The test was setup as shown in Figure 31, with current being monitored to the load from both the A and B buses and from the source to both buses, in a ring bus configuration.

The resulting individual current data shown in Figure 34, represents the expected free flow of current to the load along multiple paths. Again, verifying this data by adding the bus to load current data for the left and right side is shown in Figure 35. The results are as expected, showing that the sum of the sensors on either side of the load is approximately equal to the current monitored at the source. The discrepancy of $\sim .038$ Amperes is within the accuracy bounds specified for the LT 55-S, $\pm .9\%$ which translates to $\pm .039$ amperes.

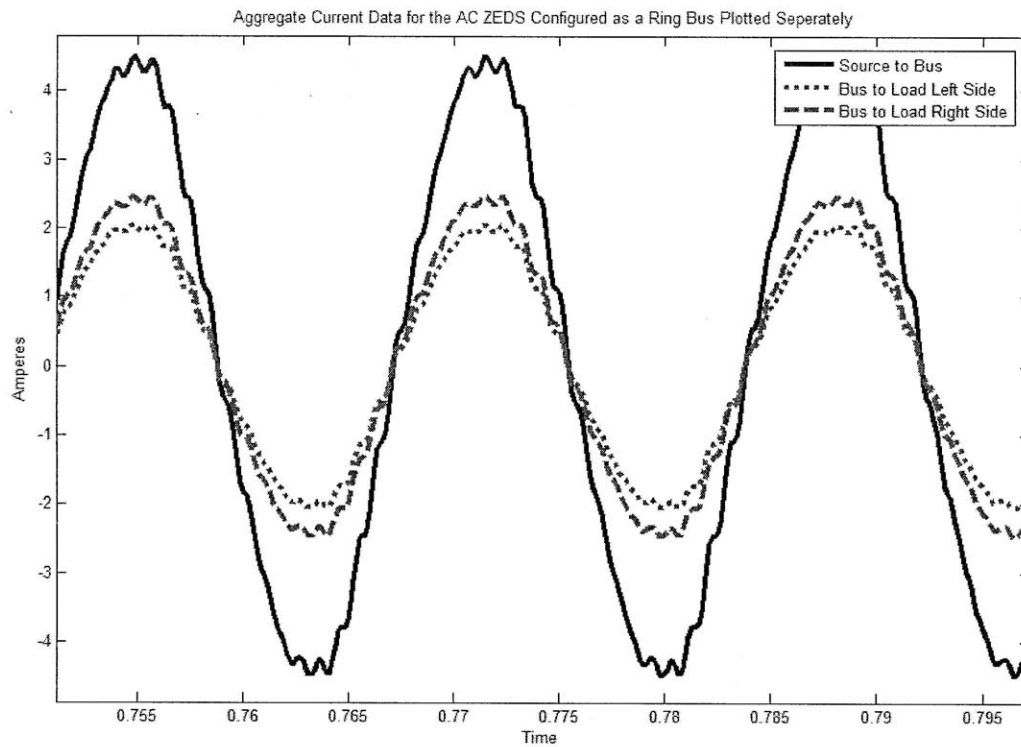

Figure 34: Individual Current Data Plot

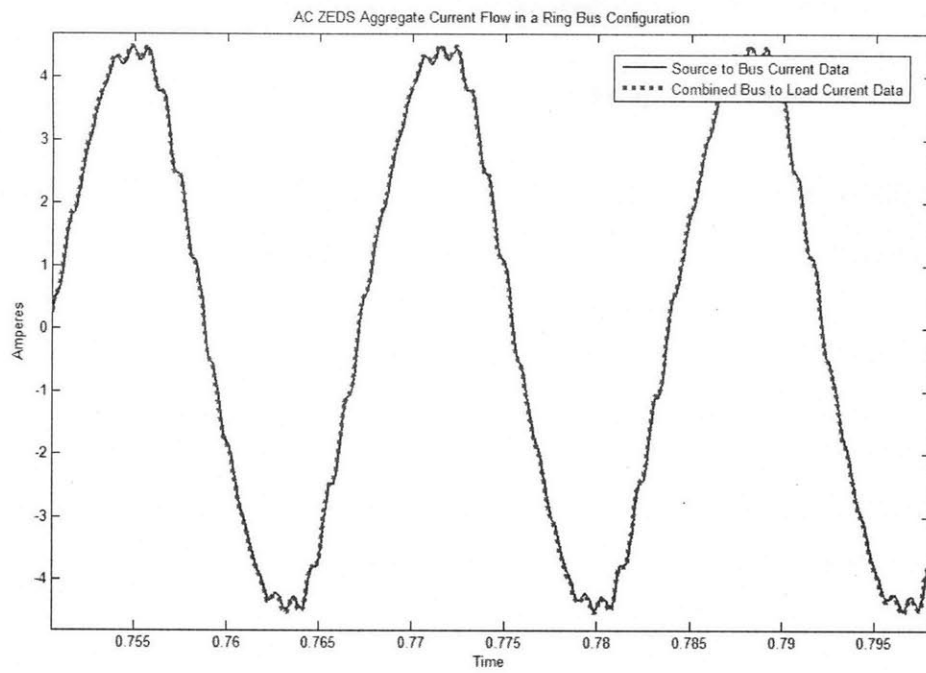

Figure 35: Combined (A and B) Load Current and Source (C) Current Comparison

6.0 The Shipboard Generation and Distribution Hardware Models

6.1 The Current Configuration of the Hardware Model of a Shipboard Generator

The intent of this section is to provide a detailed explanation of the changes made to the hardware model after [12].

6.1.1 The DC Motor Power Supply

Two new identical power supplies were bought specifically for this project. They are rated for 150 volts at 18 amperes and each one is connected to a set of two DC motors that in turn drive the generators. These power supplies are controlled through a GUI interface on the computer that manipulates the output of the USB card to control the power supplies.

6.1.2 The Field Winding Power Supply

In [12] the two power supplies that were used in parallel to drive the DC motors have been relegated to providing the excitation voltage, one for each generator. They are current limited to 3.7 amps, the generator's rated excitation current. These power supplies are also controlled through a GUI interface on the computer that manipulates the output of the USB card to control the power supplies.

6.1.3 Addition of a Second Generator

A second Mindong STC-5 generator was bought and configured to run in the same manner with the same equipment currently being used on the first generator.

6.1.4 Frequency Output

The frequency circuit built and explained in [12] was overly complicated and fraught with EMI issues. As a result, a new circuit was designed by Rachel Cheney with assistance from Zack Remscrim; the circuit diagram from PCB Schematic is shown in Figure 36. This circuit was

implemented in a PCB designed by Rachel Chaney and Zack Remscrim and produced through PCB Express.

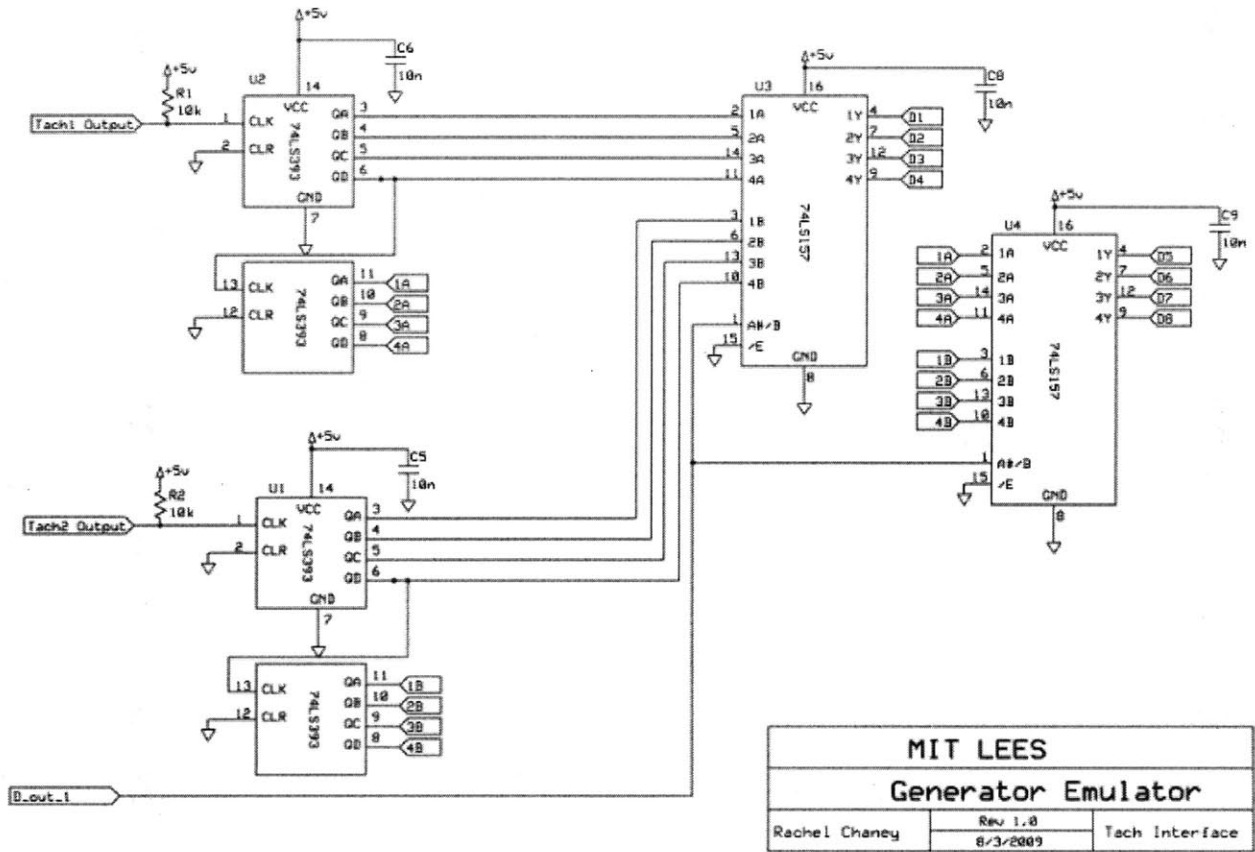

Figure 36: New Frequency Processing Circuit [17]

6.1.5 Preventing the Backflow of Power to the DC Power Supplies

An issue noted in [12] and accounted for in this thesis having to do with the generator's inertia turning the DC motors into generators when power to the DC motors is reduced or removed, is presented here. The basic concern is that accidentally transforming the DC motors into generators for even a short period of time pushes power to the DC power supply output terminals. The power supplies that are being used to drive the DC motors are not designed to receive power on their output terminals and therefore required additional protection. This protection was implemented through the use of a high voltage bridge diode on the output

terminals of each DC Motor set. Figure 37 is information that was taken from the data sheet. A simple diagram of how the system is connected is shown in Figure 38.

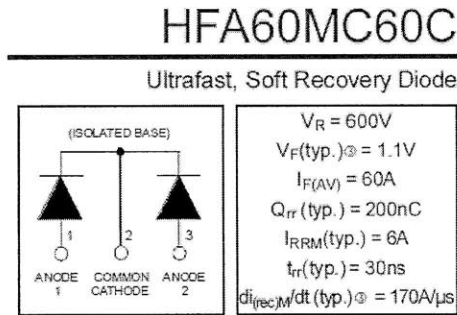

Figure 37: HEXFREDTM Diode

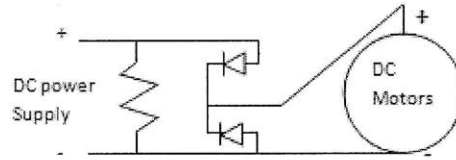

Figure 38: DC Motor Electrical Connection Diagram

6.2 The AC ZEDS Hardware Model

The intent of this section is to provide a detailed overview of the AC ZEDS distribution system down to the component level. Figure 39 is the initial design layout for the AC ZEDS board. The final hardware model of the AC ZEDS is shown in Figure 40

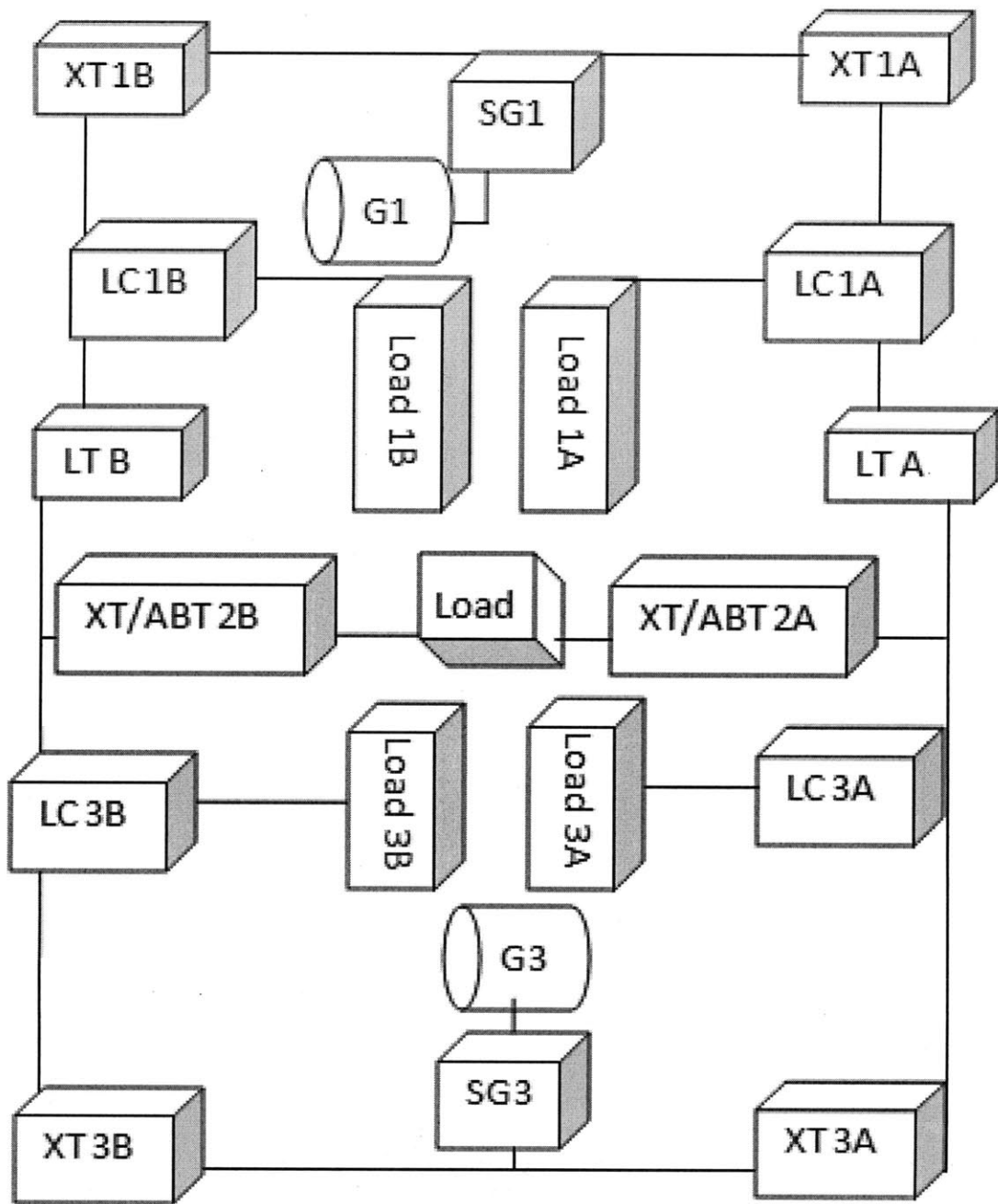

Figure 39: AC ZEDS Architecture

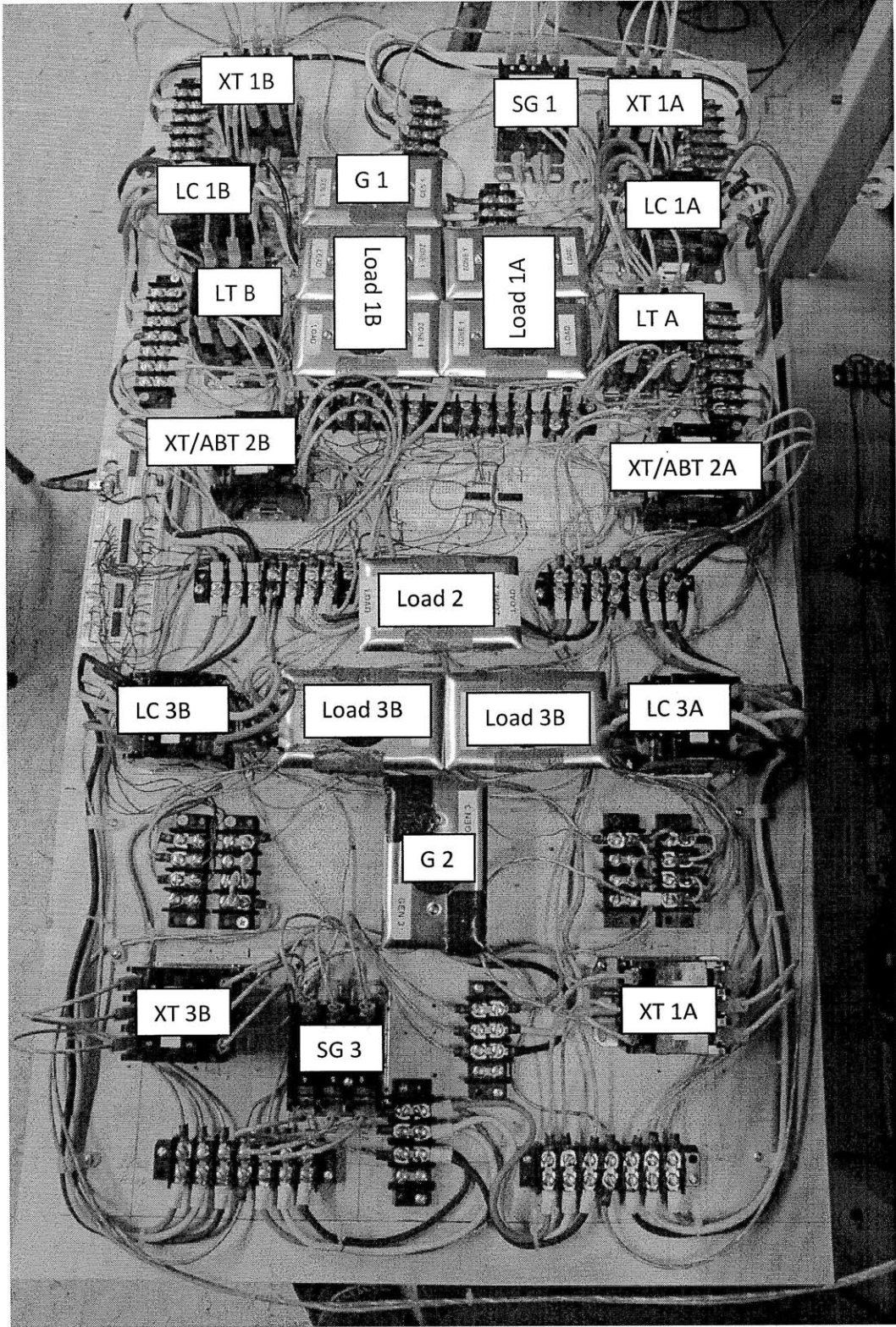

Figure 40: AC ZEDS Hardware Board Shown Setup for the Aggregate Power Test

6.2.1 The Circuit Breakers

The remotely operated circuit breakers discussed in the DDG 51 AC ZEDS configuration, specifically the XT, LT and SG breakers were emulated using the P31E contactor. This contactor allows for all three phases to be simultaneously opened or closed and provides for the maximum steady state current this hardware model will achieve. The decision making process and the other alternative investigated were explained in greater detail in the 5.0.

6.2.2 Control System for Circuit Breakers

Utilizing a PIC programmed by Jim Paris, two SL74HC595D and four L293D the fourteen P31E contactors are used to remotely control the contractors on the AC ZEDS hardware model. The GUI, generated in MATLAB is shown below in Figure 41. The associated USB Interface and circuit board is shown in Figure 42 and the electronic circuit diagram is shown in Figure 43 and Figure 44. This circuit and the P31E contactors were used to emulate the remotely operated circuit breakers. Appendix II contains the code for the GUI and the PIC.

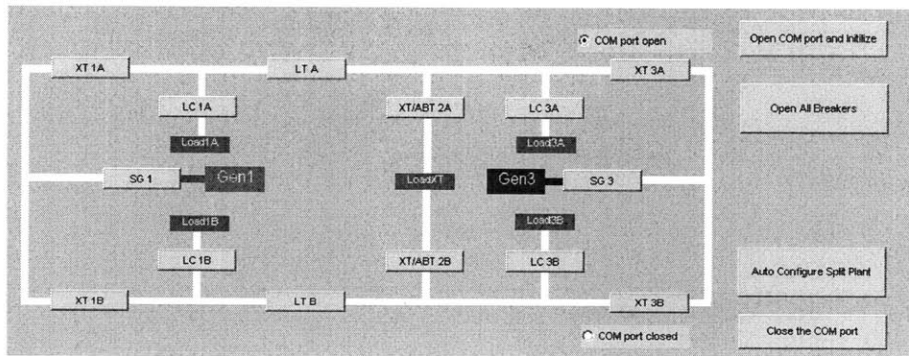

Figure 41: MATLAB GUI for Circuit Breaker Remote Operation



Figure 42: USB Interface and IC Chip Layout for the Circuit Breaker Control Board

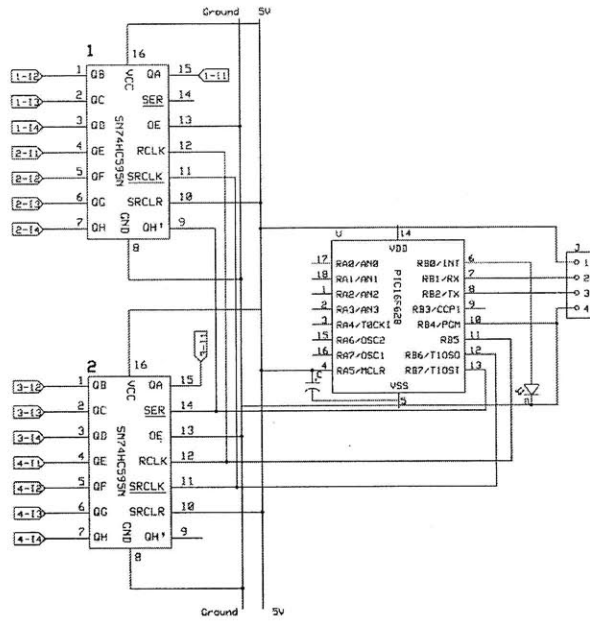

Figure 43: AC ZEDS Circuit Diagram (1 of 2)

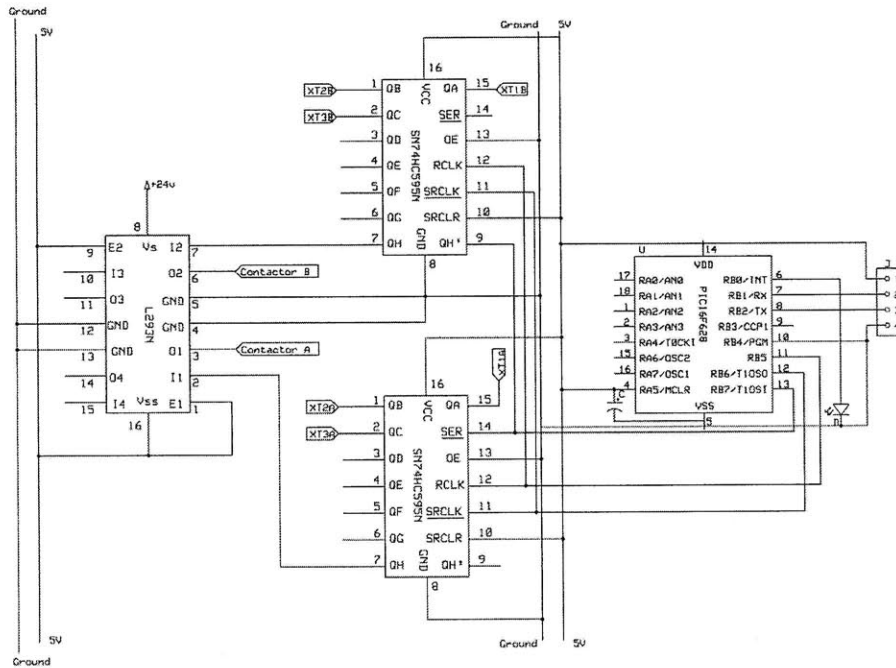

Figure 44: AC ZEDS Circuit Diagram (2 of 2)

6.3 The DC ZEDS Hardware Model

The hardware model of the DC ZEDS board electrical diagram is shown in Figure 45. This provided the guidelines to build the hardware model of the DC ZEDS shown in Figure 46. Solid State Relays are used to provide isolation and re-configurability of the distribution board. All loads are anticipated to be configured in a radial distribution configuration from one of the load centers attached to one of the two main bus lines. In turn, each bus is expected to be configured to receive rectified AC power from one or both of the AC generators.

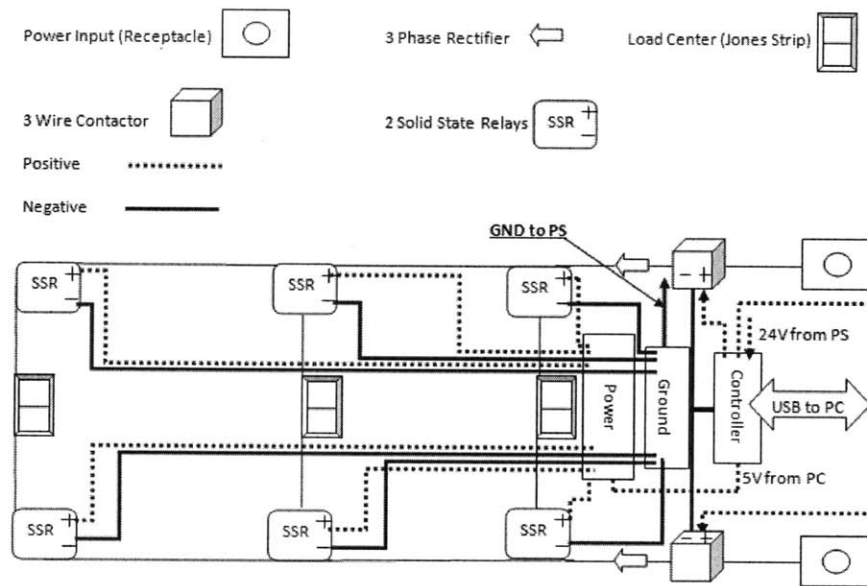

Figure 45: Electrical Diagram of the DC ZEDS Hardware Model

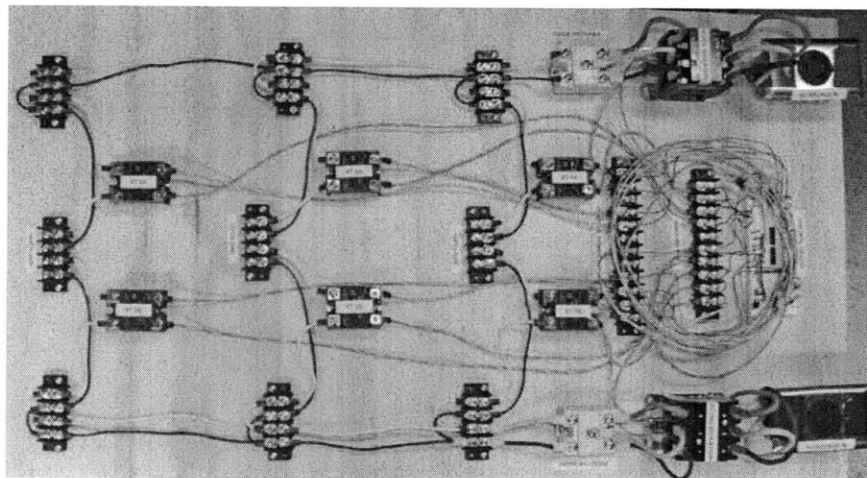

Figure 46: DC ZEDS Hardware Model

6.3.1 Circuit Breakers

The SSRs on this board are configured to be remotely operated much in the same way as the P31E contactors on the AC ZEDS board. The reason we can use the SSRs here but not on the ZEDS board has to do with the inherent differences between a SSR for AC load and for DC loads. The SSRs that can handle DC loads do not require a zero crossing to close but cannot pass AC power since they operate like a MOSFET. However, since the SSRs require much less control current to operate the L293D chip is not required and all of the SSRs are controlled by the SL74HC595 chip.

6.3.2 Rectification and Filtering

AC to DC rectification is provided on the DC ZEDS board via a bridge diode rectifier, one for each bus. The use of a passive rectifier was a preferred design based on customer feedback. One of the research avenues being pursued at LEES is the use of solid state passive filtering to remove switching distortion, a major issue for passive rectification onboard ships, on the AC side of a passive rectifier.

As noted above, a significant issue related to AC-DC rectification is the distortion imparted to the AC side of the rectifier caused by the switching. Current research being conducted by Warit Wichakool and Zack Remscrim to investigate the use of passive filtering for passive rectified AC-DC converters is summarized succinctly in the circuits and graphs shown below in Figure 49 through Figure 54. In simplest terms they have demonstrated in a program called Simulation Program with Integrated Circuit Emphasis (SPICE) that it is possible to passively filter the distortion created when using passive rectification at the level needed of shipboard systems. However the size and weight of these passive filters is a point of concern and further research into the feasibility of placing the weight and volume related to the use of passive filtering remains as future work.

The benefit derived from removal of the distortion through passive filtering includes reduction in losses, since high current peaks translate to high peak power loss based on the relation $I^2 \cdot R$.

Mitigation of voltage distortion, caused by a distorted current waveform, based on the voltage drop against the line impedance or resistance. Also, the life of the generator should be increased since the generator will not have to work as hard to provide power to the peaky loads.

One concern among potential users and designers is the level of complexity related to the full scale rectification of the entire ship generation capacity. It is not anticipated that the end user will be able or capable of conducting repairs to this system should it malfunction while underway. For the specific application being looked at, a war ship, this may be an unacceptable situation.

AC-DC Electrical Circuit Schematics and Associated Wave Form

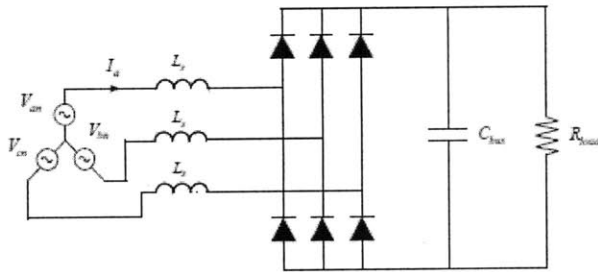

Figure 49: Passive Rectifier No Filter

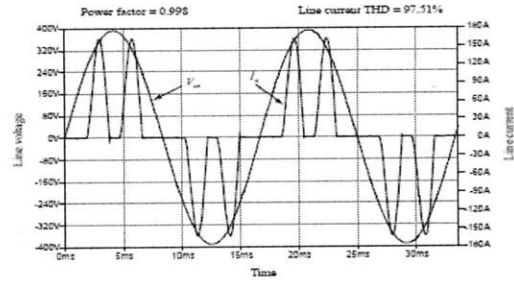

Figure 52: Wave Form of a Passive Rectifier with no Filter

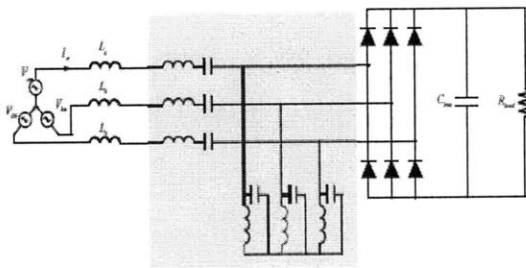

Figure 50: Passive Rectification with Filtering

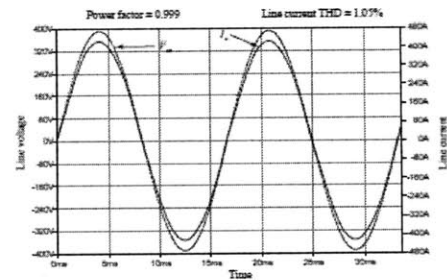

Figure 53: Wave Form of Passive Rectifier with Filtering

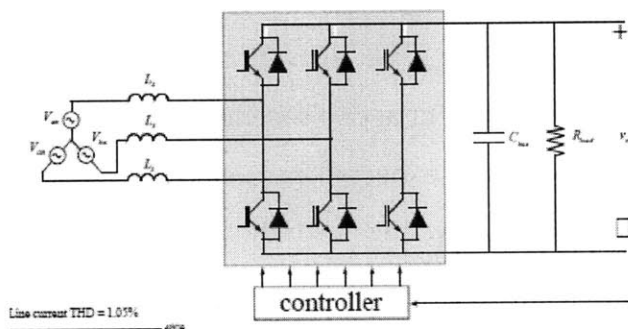

Figure 51: Active Rectification Circuit

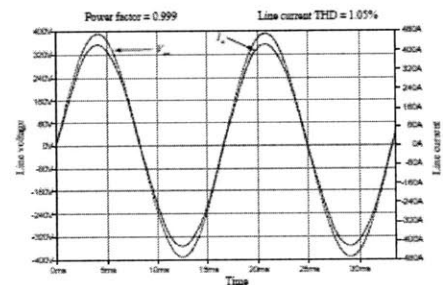

Figure 54: Wave Form of an Active Rectifier

7.0 Conclusion

The hardware model of the AC and DC ZEDS is sufficiently accurate for the purpose of conducting in lab experiments/testing for the purpose of eventual shipboard operations. With that said a fair amount of attention should be paid to similitude to ensure parity in the specific operational constraints being evaluated. For instance, when conducting fault detection and isolation testing with concurrent dynamic loading conditions; the varied loads need to be sized to ensure a relative match in magnitude compared to the fault current between the hardware model and the full scale system. Otherwise it is impossible to infer that a successful test on the hardware model will result in a successful test run in the field. The following data was taken to test the AC ZEDS board under different loading parameters. The test setup was the same for all of the experiments and included monitoring the current and voltage, line to neutral, on phase A at three different points on the AC ZEDS board: on the generator side of SG 1, at the load side of LC 1B and at the load side of LC 3B.

For this test the generator was brought up to speed and both loads were applied. The generator was then brought back up to 60 Hz operation at $120V_{L-N}$. Then the loads were removed the system was given time to stabilize and then data collection was initiated. At approximately one second the motor load was applied and then at approximately two seconds into the data collection the lighting load was applied.

Figure 51, shows the motor voltage, with the expected transient at one second. Figure 52, shows the voltage corresponding to the lighting load with the expected transient at approximately 2 seconds. Figure 53 shows the source to bus voltage with the expected transient responses at 1 and 2 seconds.

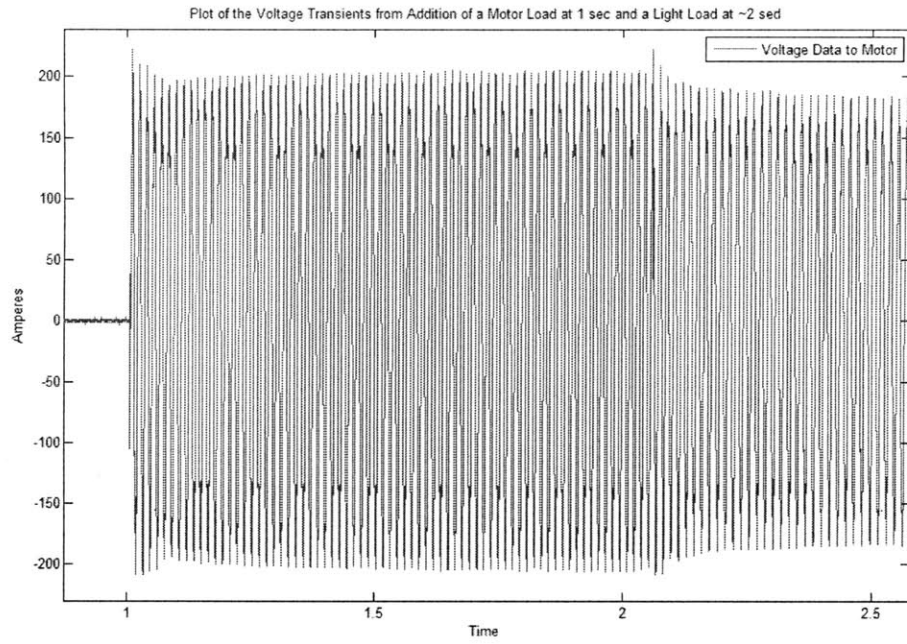

Figure 55: Motor Load Voltage Data

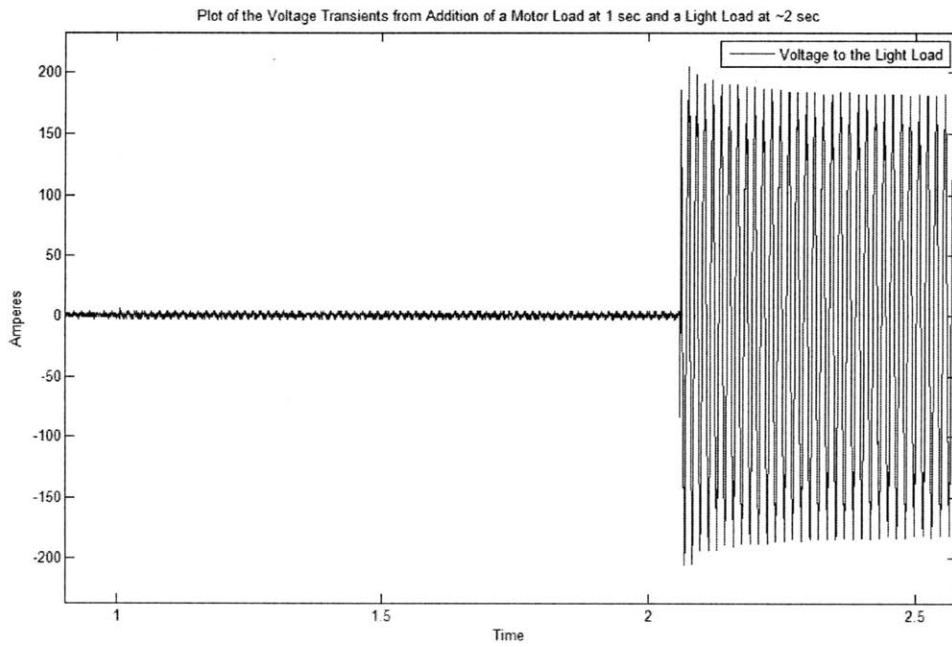

Figure 56: Lighting Load Voltage Data

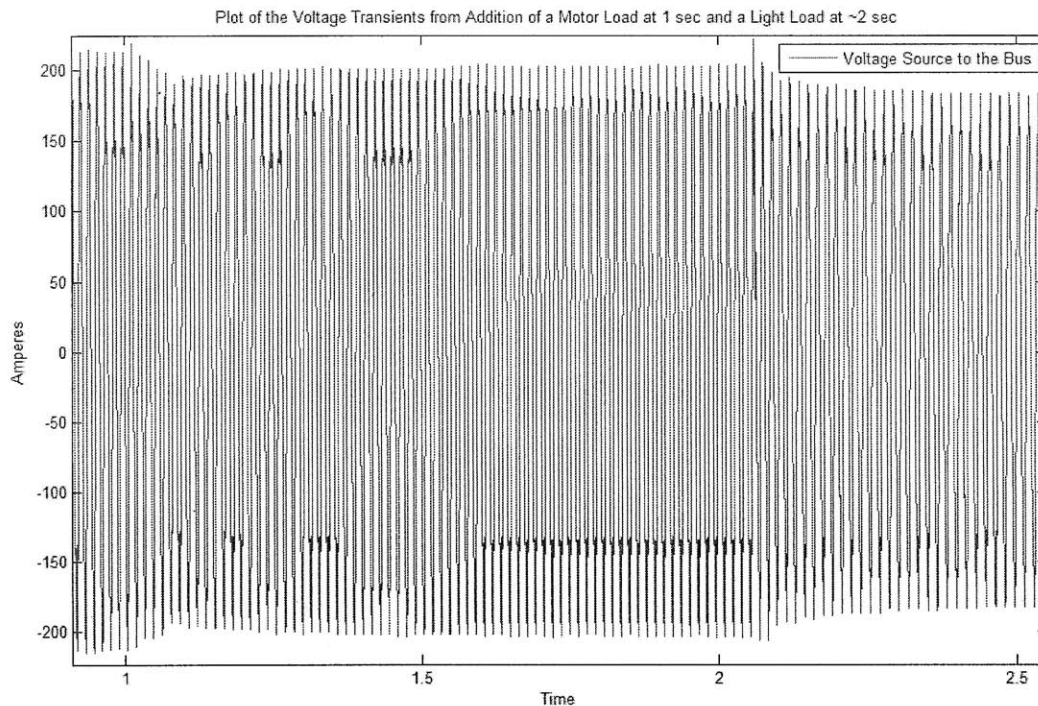

Figure 57: Source to Bus Voltage Data

7.1 Additional Work

7.1.1 Circuit Breaker Emulation

In order to realize the switching speed currently built into the existing DDG 51 class AC ZEDS system, through the use of the MFM III, a fair amount of work still remains. The current 3 cycles it takes to open the P31E contactor equates to approximately 500ms. This break time appears to be related to the time it takes to dissipate the magnetic field to a level where the spring can open the circuit.

The target goal of 10ms from fault detection to isolation, as stated in the “A Guide to MFM III Operation” written by NAVSEA Philadelphia is not even remotely close to being realized in the current version of the hardware model. Focusing on the contactor will provide the biggest gains in relation to achieving a level of switching speed in the vicinity of 10ms. The solid state relay is able to trigger at 6ms leaving 4ms for detection, classification, and order dissemination.

7.1.2 Automatic Paralleling of the Generator

Although this system is currently capable of being manually configured for parallel generator operations an automatic paralleling algorithm is needed in order to test any automatic reconfiguration of the distribution system, in response to an electrical fault current or otherwise.

7.1.3 GUI and Control Improvements

Additional work on the circuit breaker control topology to prevent unintended operation, error checking, is another area where the system as is could be drastically improved. This will also enhance safety by providing a means to prevent inadvertent connection of two separately powered busses.

7.2 Future Studies

7.2.1. Doubly-Fed Machine

One potential answer to the current issues related to not have the right level of power density at the component level for a MVDC distribution system is the use of a doubly-fed machine. A doubly-fed machine would reduce the total amount of power needed to be rectified and distributed on the DC bus as it requires much less power for the same torque and speed, compared to a synchronous machine [18]. A doubly-fed machine has windings on both stationary and rotating parts, both windings transfer significant power between the shaft and the electrical system.

Further testing on the AC/DC benchtop emulators could provide valuable insight into the feasibility of using this system in a US Navy IPS.

7.2.2 Non Intrusive Load Monitoring

Development of a DC fault detection and isolation methodology is of vital importance to eventually moving the shipboard DC ZEDS from the concept phase to a full scale system. The NILM system used at MIT's LEES may be an enabling technology. The use of NILM on the DC

ZEDS benchtop emulator should provide a unique opportunity for testing out this area of research.

Bibliography

- [1] Naval Sea Systems Command, *A Guide to MFM III Operation*. Philadelphia: NSWCCD-SSES
- [2] "60Hz Distrabution," in *Information Sheet Number 64A9-302 of the SWOS Training Guide*,
- [3] Naval Sea Systems Command, *Naval Ship Technical Manual Chapter 310, Electrical Power Generators and Conversion Equipment*, S9086-KN-STM-010/CH-310R2, September 1999
- [4] Naval Sea Systems Command, *Naval Ship Technical Manual Chapter 320, Electric Power Distribution Systems*, S9086-KY-STM-010/CH-320R2, 21 April 1998
- [5] NKO online training DDG 51 Class Hull number 78-90 AC ZEDS training
- [6] NKO online training DDG 51 Hull number 91 and higher AC ZEDS training
- [7] N. Doerry, *Next Generation Integrated Power Systems (NGIPS) for the Future Fleet*. Baltimore : Naval Sea Systems Command, 2009.
- [8] D. C. Brick, P. E. Jordan, D. N. Pegram, J. K. Taylor, M. Kasson, J. Shegirian, and G. D. Stevens, "Engineering Report – Shipyard Team Review of Next Generation Integration Power System Architectures," Northrop Grumman and General Dynamics, Contract N00024-06-C-4202TI#007, Report NGIPS/TR-09-07/001 of Sept 28, 2007.
- [9] S. Surko and M. Osborne, *Operating Speed Profiles and the Ship Design Cycle*, Naval Engineers Journal, Vol 117, Issue 3, Pg. 79-85, ASNE 2005.
- [10] J. T. Leghorn, *Modeling for Ship Power System Emulation*. Cambridge: Massachusetts Institute of Technology, 2009
- [11] E. Hall, *On a New Action of the Magnet on Electric Currents*. American Journal of Mathematics 2 (3): 287-92. 1879.

- [12] G. Elkins, Hardware Model of a Shipboard Generator. Cambridge: Massachusetts Institute of Technology, 2009
- [13] "LabJack UE9 User's Guide," Mar. 10, 2010. [Online] Available: http://labjack.com/sites/default/files/2009/07/LabJack_UE9_Users_Guide.pdf. [Accessed May 12, 2010].
- [14] E. Rechtin and M. W. Maier, The Art of Systems Architecting, Florida: CRC, 1997.
- [15] McMaster-Carr Homepage, [Online] Available: <http://www.mcmaster.com/>. [Accessed May 12, 2010]
- [16] LEM Homepage, [Online] Available: <http://www.lem.com/hq/en>. [Accessed May 12, 2010]
- [17] R. Chaney, [thesis title?]. Cambridge: Massachusetts Institute of Technology, 2009
- [18] S. B. Leeb and R. Cox, Role of the Combat Power Monitor in Zonal Electrical Distribution in the NGIPS. *Whitepaper*. Boston : MIT/Laboratory for Electromagnetic and Electronic Systems, 2008.

APPENDIX I – Operator Manual

High Level Architecture

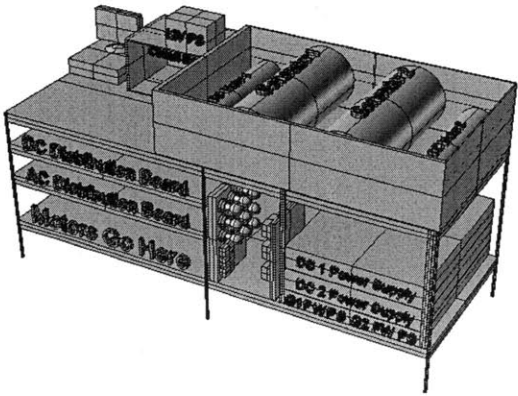
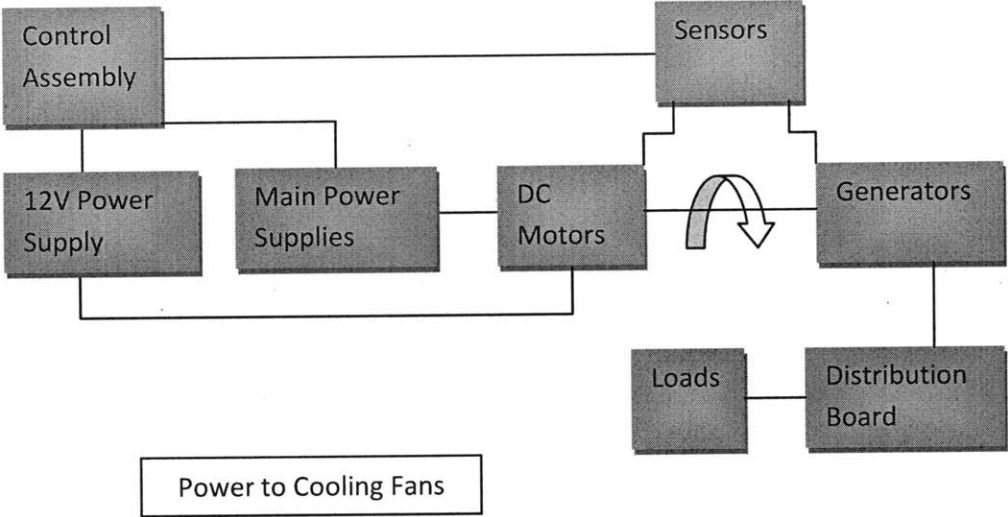

PS 1

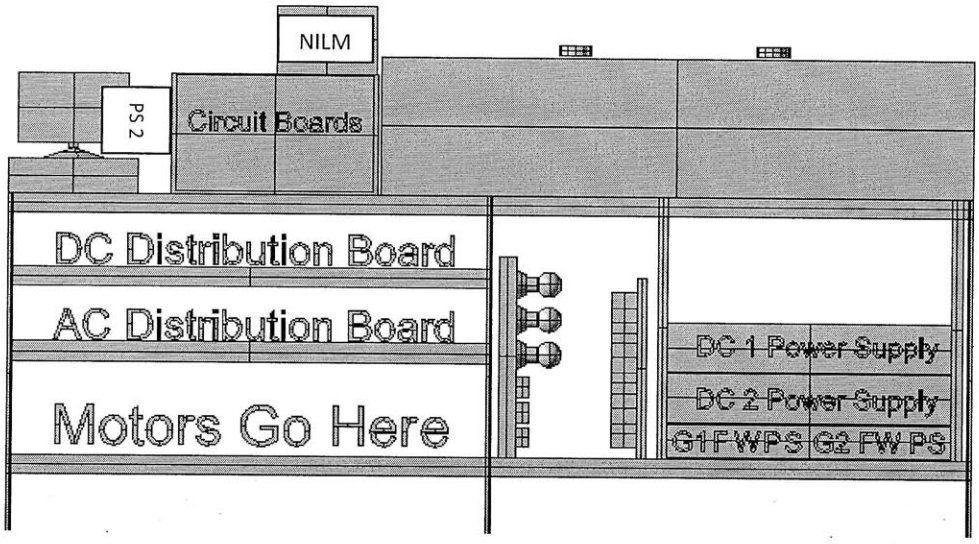

Detailed System Level Layout

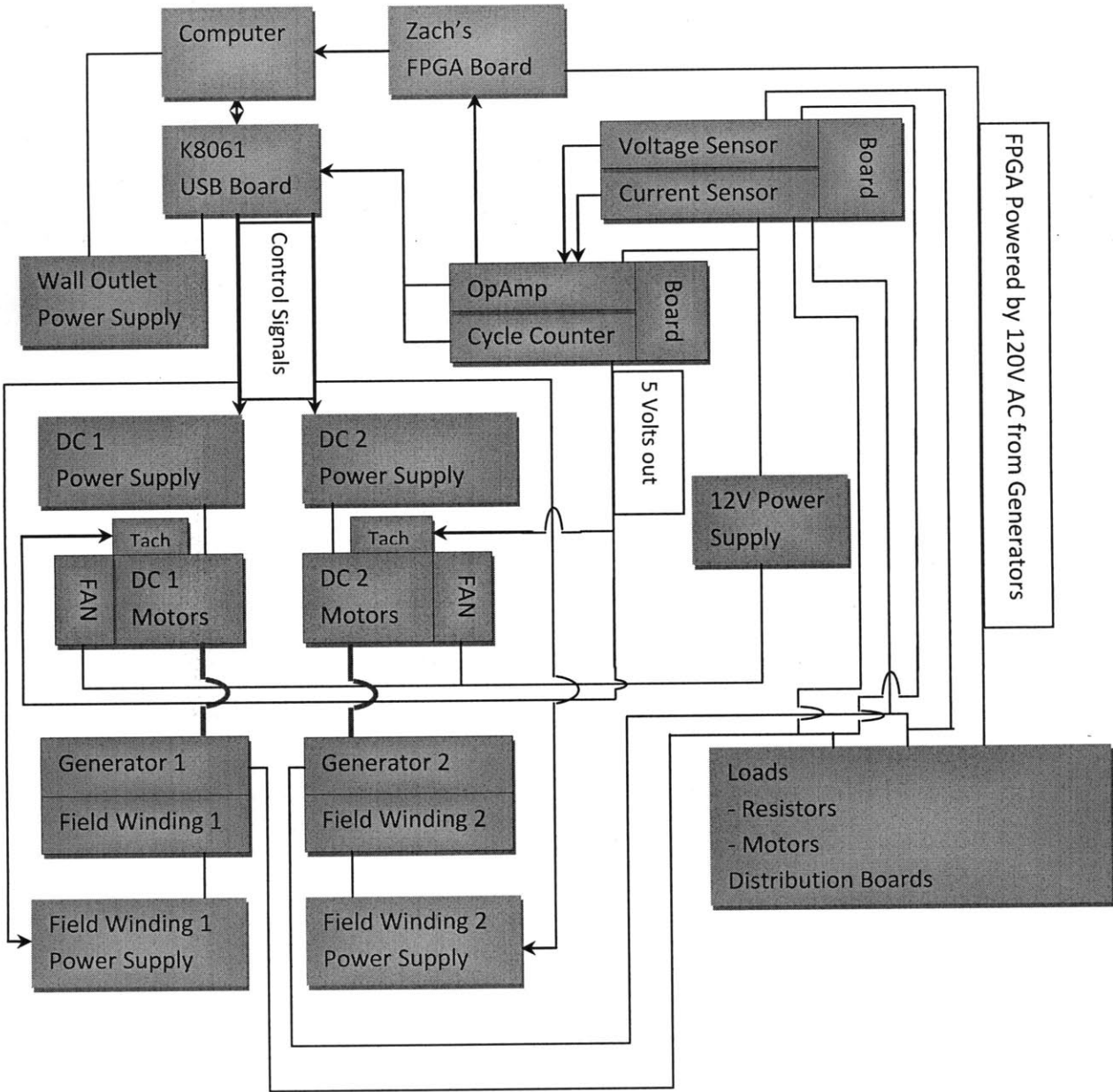

I. OPERATION OF THE GENERATOR AND DISTRIBUTION MODELS

1. BEFORE STARTING This system at any time:

- a. Verify all physical connections and fasteners are properly secured
 - i. DC motor clamps are tight and do not allow the motors to wiggle

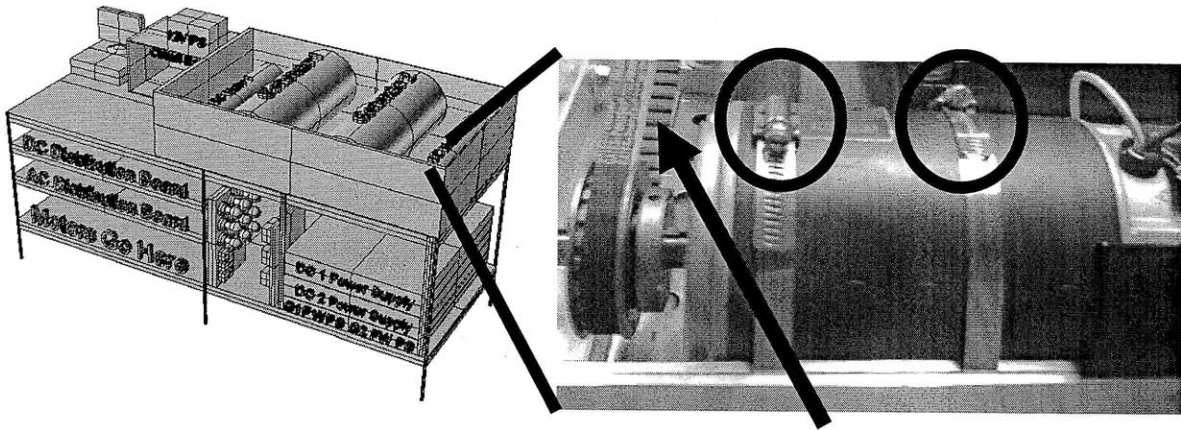

- ii. Drive belts are taught (not loose or overly tight)
- iii. Generator mounting bolts on the base of the Generator
- iv. DC Motor coupling and set screws between each DC Motor

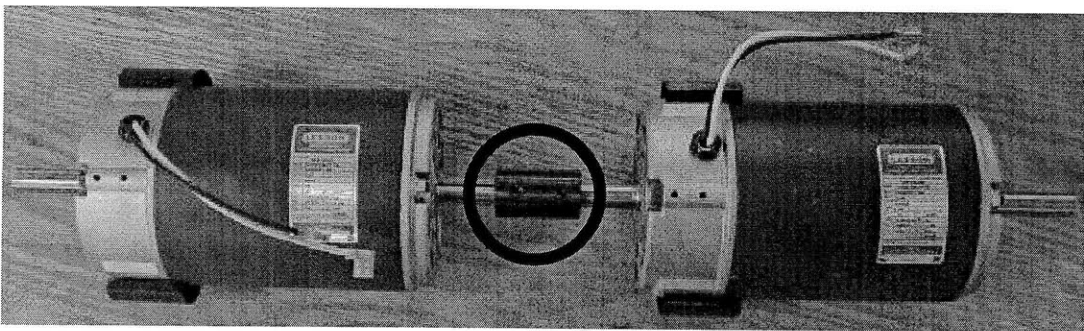

- b. All electrical connections are properly connected
 - i. Generator output terminals are tight
 - ii. Both generator power cables are connected in the appropriate electrical receptacle (Either Gen1 or Gen3 from the AC or DC ZEDS diagrams)
 - iii. Power is connected to the DC Motor fans
 - iv. Power is connected between the power supplies labeled DCM 1 and 2 to the DC Motors labeled DCM 1 and 2 as shown below

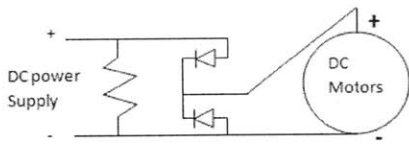
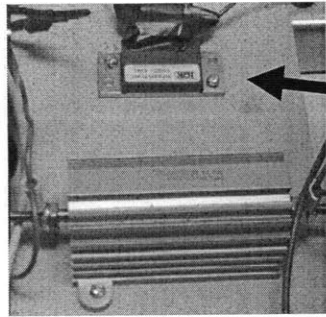

Figure 35: Basic Circuit Diagram



HFA60MC60C
Ultrafast, Soft Recovery Diode

ISOLATED BASE:		
1	2	3
ANODE	COMMON CATHODE	ANODE

$V_R = 600V$
$V_f(\text{typ.}) = 1.1V$
$I_{F(AV)} = 60A$
$Q_{rr}(\text{typ.}) = 200nC$
$I_{SM}(50\mu s) = 6A$
$t_{rr}(\text{typ.}) = 30ns$
$\theta_{jmc-MB}(\text{typ.}) = 170A/m^2$

Figure 36: HEXFRED™ Diode

v. Power is connected between the DC1 and DC2 power supplies and the Field Windings of Generator 1 and 2 respectively.

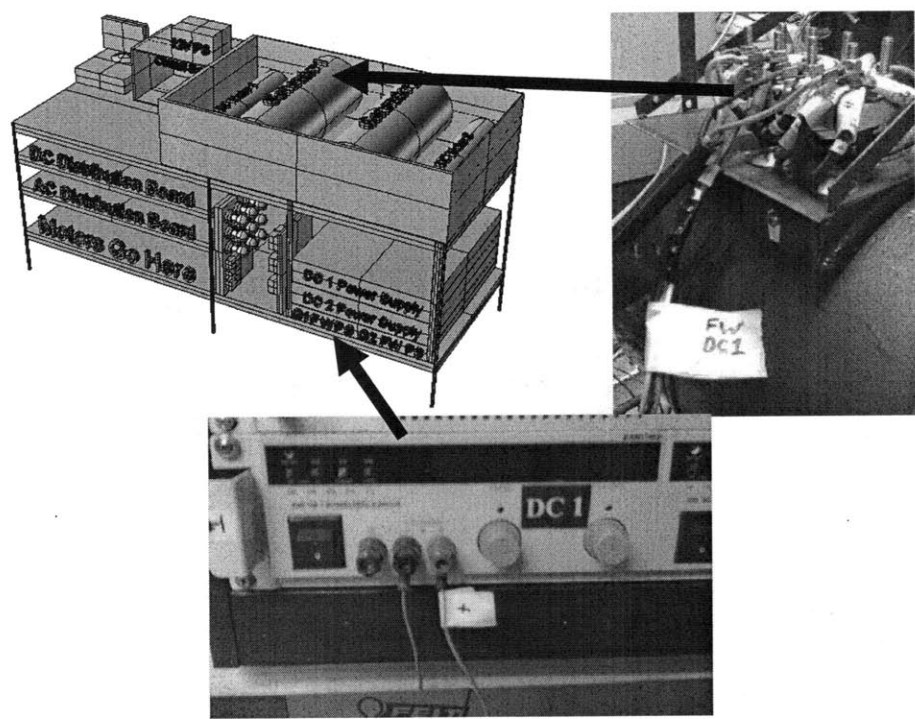

vi. Power is connected to the circuit boards

1. USB board both the USB cable and the power cable need to be plugged in.

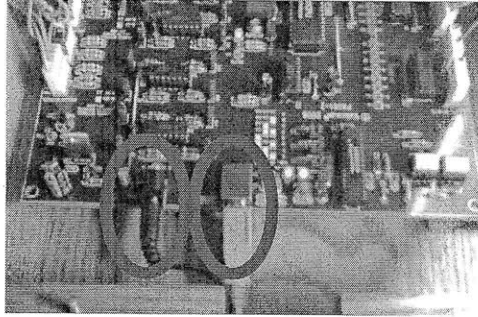

2. Frequency (counter) board, to the right of the USB card as pictured here. Should receive $\pm 12V$ and ground through three cables (red, green, and black) from a suitable power supply.

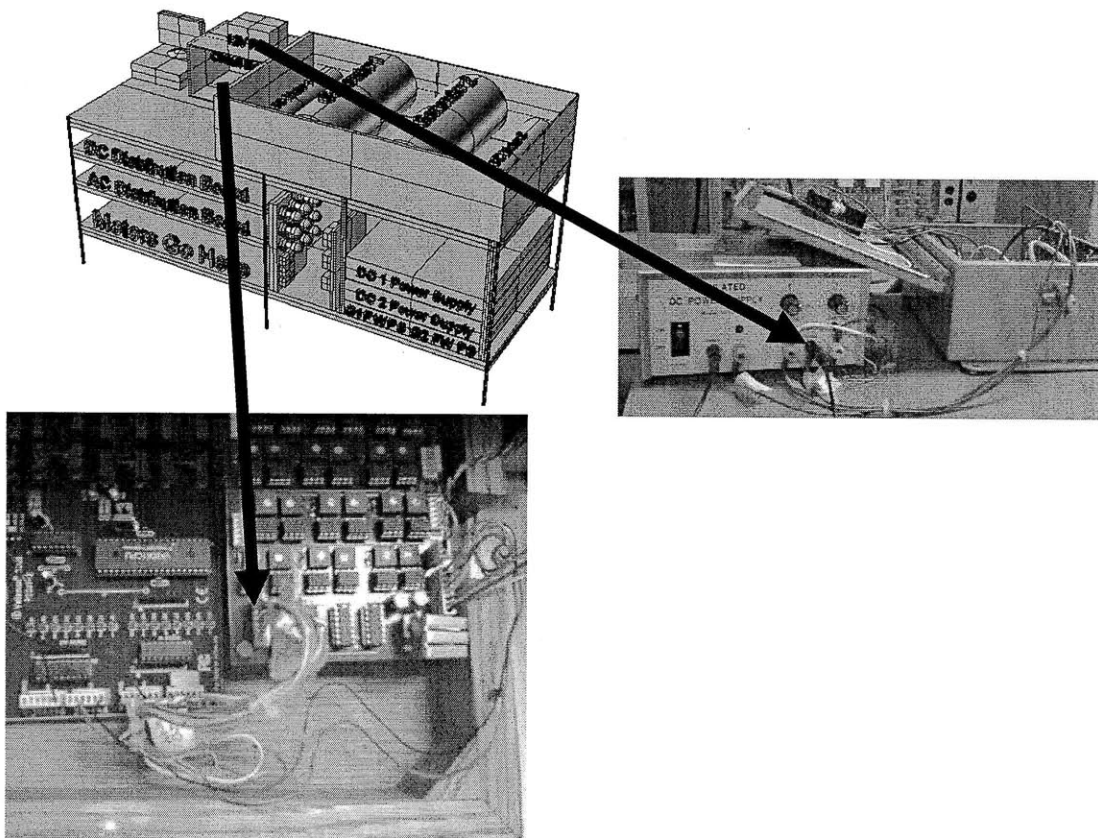

3. Contactor control circuit board receives power from the USB adapter for the chip logic and 24V from a suitable power supply on

pin 8 of the L293N chip. Also verify that all the grounds are connected.

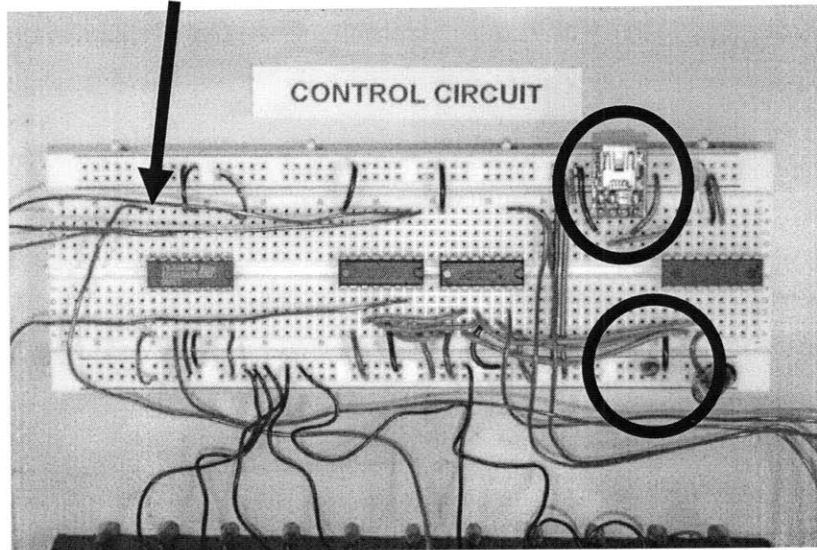

- vii. Power is connected to the speed sensors through the frequency circuit board. The 8 pin connector next to the power connector on the frequency (counter) card.

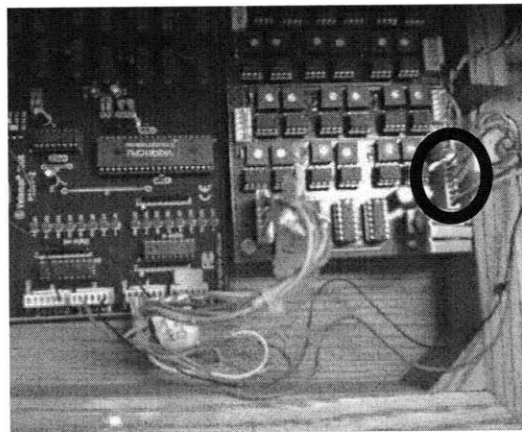

- viii. Circuits are all grounded to their respective power supplies
 1. Frequency (counter) board, PS1, USB Board, and Computer
 2. Contactor control circuit board, PS2 and Computer
 3. SSR control circuit board
- ix. Earth ground is connected (as applicable)
 1. Generators
 2. AC ZEDS board
 3. DC ZEDS board

4. Leeb's board
 5. Loads
- c. Verify all rotating equipment can freely rotate and are not obstructed
 - i. Generators
 - ii. DC motors
 - iii. Motor loads
 - d. Verify proper clearances for equipment that produce heat
 - i. Lighting loads (heat)
 - ii. Generators
 - iii. DC motors
 - iv. Other loads
 - e. Verify power supply one (PS1) , I used the brown power supply model number 3010, is set up for operation

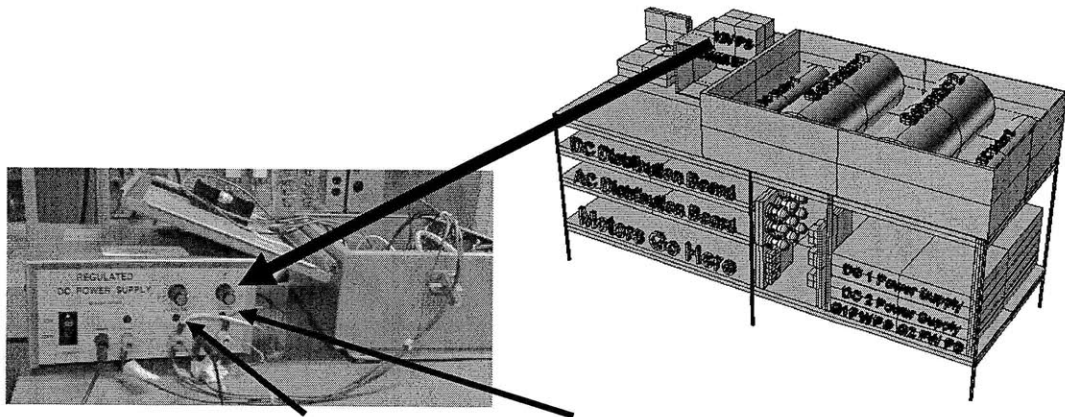

- i. +12 V (white wire) and -12 V (blue wire) to both DC Motor fans
- ii. 5 V, ± 12 V and Common (blue wires with tape labels) to the NILM box

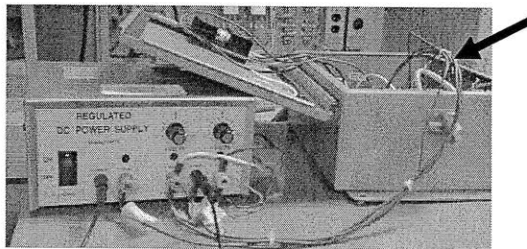

- iii. +12 V (red wire), -12V (green wire) and Common (black wire) to the Frequency (Counter) Opamp circuit card

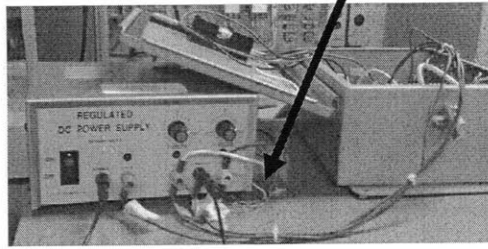

- iv. Connect the 5v and ± 12 Volts commons

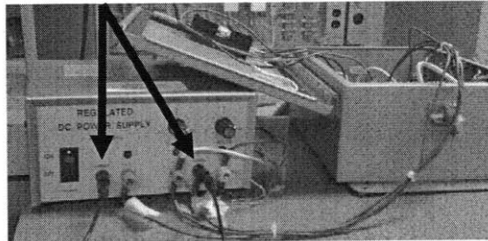

- f. Verify power supply two (PS2), I used the White power supply model number HY3003, is set for 24 volts and 3 Amperes, it is currently on top of the PC behind the monitor.

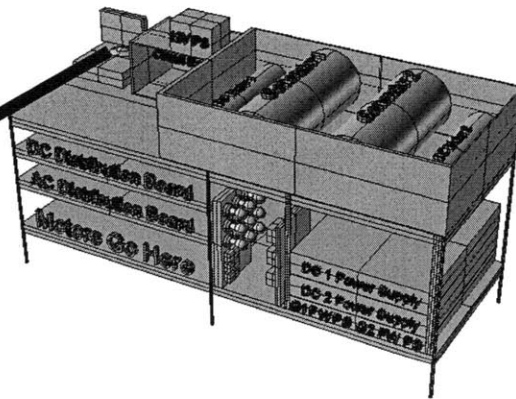
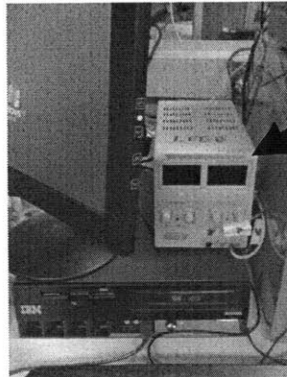

- i. +24V to the AC and DC ZEDS board the pink wire leading to the AC ZEDS Board and/or DC ZEDS board
- g. Open the Generator Control GUI on the desktop: GeneratorController.exe
 - i. The file is located in the following directories:
 1. C:\Program Files\Nerdjack\GeneratorController.exe
 2. C:\Documents and Settings\student\Desktop

The following GUI should be displayed on the computer monitor:

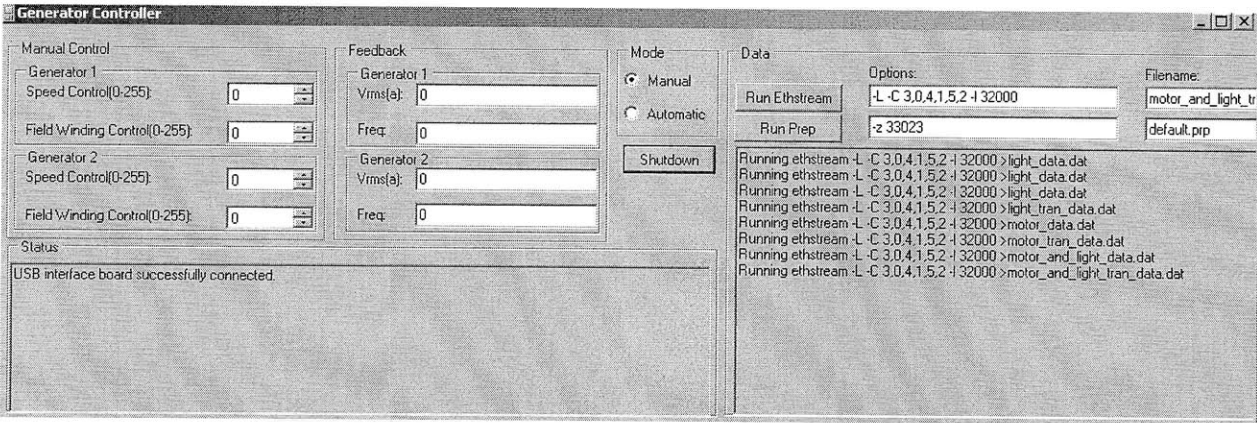

h. Open MATLAB

- i. Execute the MATLAB GUI: [C:\Documents and Settings\student\My Documents\MATLAB\zeds_gui_v3.m]
- ii. Then after the editor opens press the green arrow to execute the script the following figure should appear on the desktop

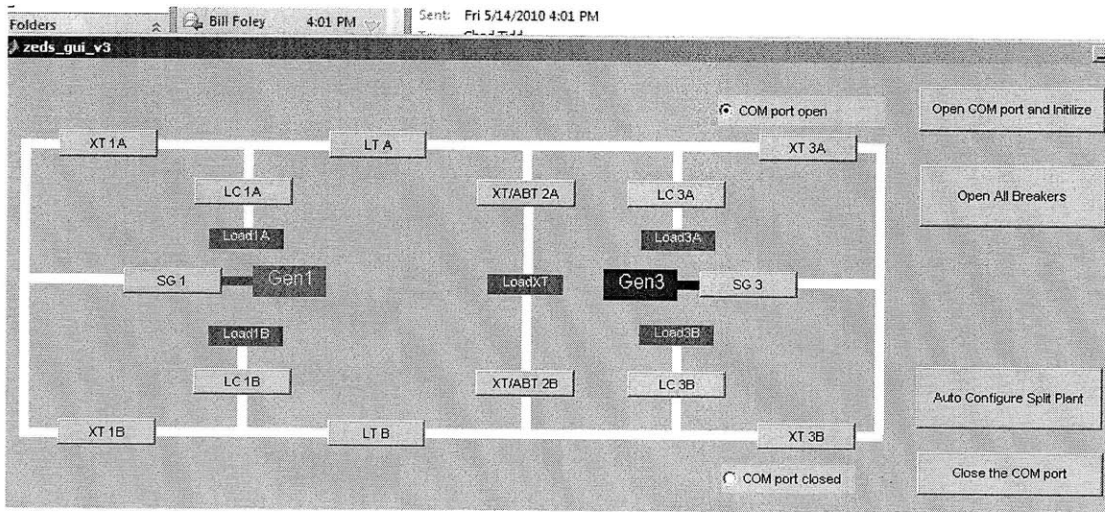

- iii. Next press the button on the GUI labeled: Open COM port and initialize
- i. Turn on power supplies for:
 - i. Circuit Breaker Control
 - ii. DC Motor fans, NILM power, and control circuitry power
- j. Verify positive control of all circuit breakers through the GUI
 - i. Then configure the contactors as desired

- k. Before bringing any generator online ensure that the generator contactor (SG1 and/or SG2) are open.
- l. Ensure that the cross tie (XT) and longitudinal tie (LT) breakers are either all open or set in the desired position.
- m. Make sure that the manual voltage control is set at the position which gives the lowest ac generator voltage. Field windings set at zero on the GUI.
- n. Verify positive control of generators by increasing the speed to 15 on the generator GUI. Generator should spin slow and smooth. Then stop the generators by pushing the shutdown button, the generator GUI should reduce to zero and the generator should stop.

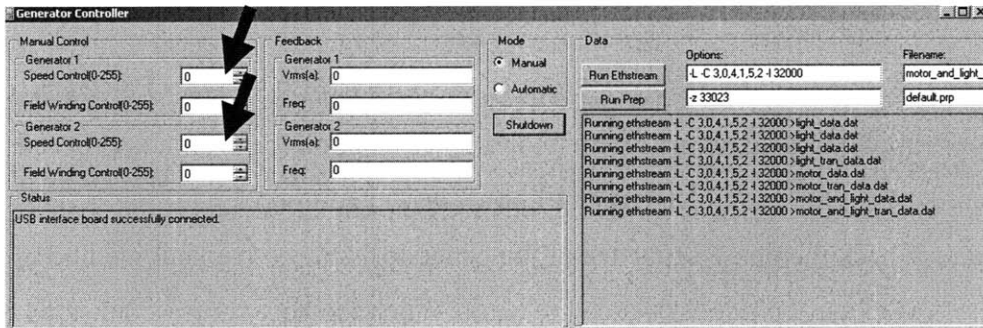

- i. If any of the above steps do not produce the desired response stop all work and begin troubleshooting by looking at all connections, **do not proceed to full speed/load testing** until all issues have been rectified.
- o. Verify positive control of the Field Windings by entering 10 in the Field Winding Control box and pressing enter. Verify the DC power supply corresponding to the generator you are trying to control increases in voltage and current.

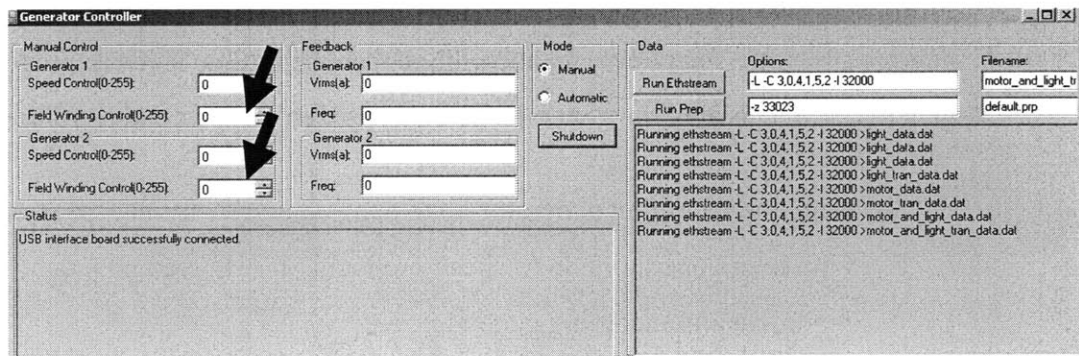

At this point you are now able to spin the Generators and apply excitation voltage to produce power on the output terminals of the generator. It is very important that you have verified that the connections prior to starting the generators. Additionally the guards for the generator terminals and any additional safety devices/guards should be in place prior to spinning the generator. If at any time unusual or unexpected behavior is witnessed from the generator, shut it down with the shutdown button on the generator GUI and disconnect the power to the power supplies immediately. Commence trouble shooting by verifying all electrical connections and grounds. If needed seek advice or help from other lab members, sometimes an extra set of eyes is all that is required.

II. BEFORE APPLYING LOAD AFTER INSTALLATION OR OVERHAUL.

1. Before applying load to an ac generator after installation or overhaul, proceed in accordance with section I-III as appropriate and in addition:
 - a. Check the phase sequence of the generator. One convenient method of doing this is to use a phase sequence indicator. When the generator is connected to the switchboard buses, the phase sequence of the buses should be A B C.

III. SYNCHRONIZING FOR PARALLEL OPERATION

1. If the bus is already energized, never close the generator circuit breaker unless the generator and bus have approximately equal voltages and are in phase.

*** Note that the method used to verify phase is in development***

If the generator is not in phase at the time the circuit breaker is closed excess forces are developed in the generators and accordingly care should be taken to properly parallel the generators. To parallel the generator to an energized bus proceed as follows:

- a. Bring the incoming generator up to approximately normal speed and voltage
- b. With both generators up to speed producing 60 Hz read generator voltage of both the online and incoming generator.
- c. Adjust voltage of the incoming generator to match the online generator.

- d. Verify the frequency of the generators match.
- e. Use the synchronizing lamp or appropriate equipment to verify the phases are aligned within ten degrees.
- f. When using synchronizing lamps the circuit breaker should be closed just before the midpoint of the dark period of the lamps is reached.
- g. Close the generator circuit breaker or the appropriate cross tie circuit breaker to parallel the generators.

IV. ADJUSTMENT FOR PARALLEL OPERATION.

1. Whenever ac generators are operating in parallel, the kilowatt loads and the current readings should be proportional to the generator ratings, and, if power factor meters are installed, the power factors should be equal. The desired division of the kilowatt load is obtained by adjusting the settings which control the speeds of the generators. Equal kilowatt load division is obtained automatically in the isochronous mode (**Isochronous mode Not currently available s of 5/10/2010**) and by adjustment of the speed settings in the droop mode. Proportional division of generator currents and equality of power factors are obtained by adjusting the voltage by controlling the voltage and current to the field windings after the kilowatt load division has been adjusted. These adjustments are made as follows:
 - a. Make necessary adjustments to equalize wattmeters (**There is no wattmeter currently available in the system as of 5/10/2010**) to have equal readings (if the generators have the same rating) or so that the kilowatt load is divided in proportion to the generator ratings (if the generator ratings differ from each other). For systems operating in speed droop:
 - i. If the frequency is above normal, slow down the heavily loaded generator.
 - ii. If the frequency is below normal, speed up the lightly loaded generator.
 - iii. If the frequency is normal, make the adjustment in small steps. Turn the governor control switches for the lightly loaded generators in the increase speed direction and for the heavily loaded generators in the decrease speed direction.

- b. Adjust the voltage by controlling the DC power supplies to the field windings.
Adjust the line currents until they are divided in proportion to generator ratings or power factor readings are equal.
2. If the voltage is above normal, adjust the field winding control to a lower value for the generator with more than its fair share of line current (lowest power factor).
3. If the voltage is below normal, adjust the field winding control to a larger value for the generator with less than its fair share of line current (highest power factor).
4. If the voltage is normal, make the adjustments in part 2 and 3 in small steps.

V. SECURING.

1. To secure an ac generator which is connected alone to the bus, hence, not operating in parallel with any other machine:
 - a. Reduce the load on the generator as much as practicable by opening feeder circuit breakers on the power and lighting circuits. **(Open all circuit breakers as a default)**
 - b. Open the generator circuit breaker (SG1 or SG2).
 - c. Check whether Field Winding control is in the MANUAL position; if not, turn it to the MANUAL position. **(Manual is the only form of control as of 5/10/2010)**
 - d. Reduce the Field Winding Control to zero.
 - e. Secure the prime mover in by pressing the shut down button or reducing the DC motor control to zero, gradually.
 - f. Secure power to the Circuit Breaker Control, DC Motor, and Field Winding power supplies.
 - g. Verify DC Motor temperatures are not excessive and secure the remaining power supply. If the DC Motors feel excessively warm keep the FAN power supply on for five minutes then check again.

VI. SECURING AFTER PARALLEL OPERATION

1. To secure an ac generator which has been operating in parallel with another generator, or with other generators:

- a. Adjust the DC motor control of the generator being secured in to decrease speed and increase the speed of the other generator until the entire load has been shifted from the machine being secured. This may be checked by reading the wattmeters **(Not currently available as of 5/10/2010)**. If the total connected load is greater than can be carried by the machine which is to continue operating, it will be necessary to decrease the load by opening load center (LC) circuit breakers.
- b. Trip the circuit breaker of the generator being secured.
- c. Proceed in accordance with Section VIII.

The NILM

1. The NILM used for my thesis was powered by the brown power supply model number: 3010. This power supply provided the $\pm 12V$, 5V and Ground, in order to operate properly both common terminals for the 5V and $\pm 12V$ had to be connected to the ground terminal of the NILM box.

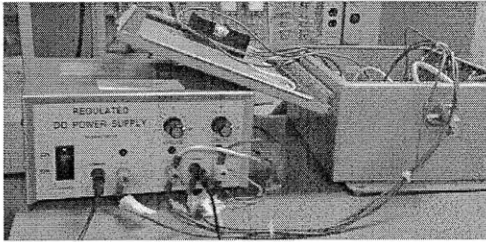

2. The NILM current sensors lines were marked to make identification at the board level easier. This picture is of the back or top of the NILM depending on your perspective.

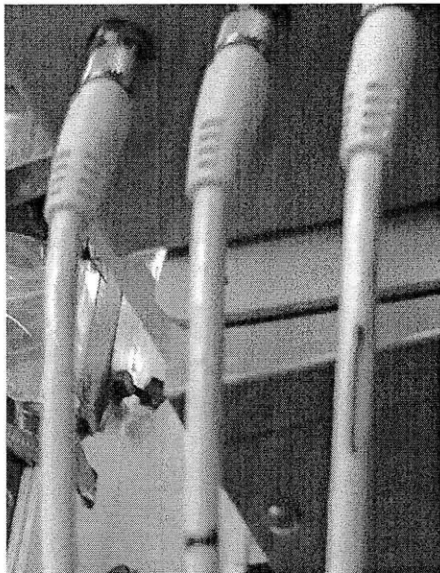

3. The NILM can be configured in either a Y or delta connection however modification to the terminal board within the NILM is required. As of 5/10/2010 the NILM is configured for line to neutral readings and requires the white lead coming from the NILM to be connected to the neutral wire on the distribution board. In Delta the terminals must be reconfigured to read the difference between the two line voltages AB, BC, and CA for example.

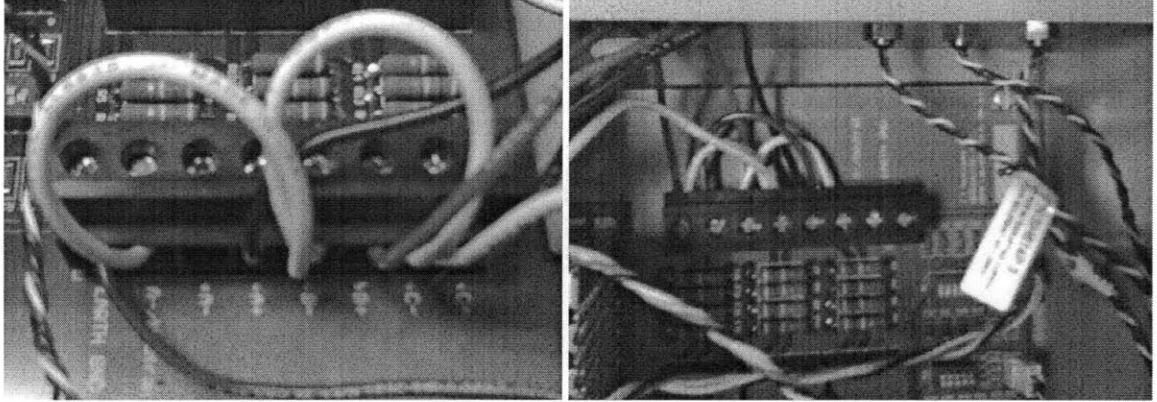

In the Y configuration the white wire is the neutral and connects to the -A, -B, and -C terminals for V_{L-N} readings. In the Delta configuration three separate wires connect -A to +B, -B to +C and -C to +A. This allows for V_{L-L} applications there is no neutral or earth ground.

4. The current sensors that come with the NILM used for my thesis, LA 55-P require a resistive element in series with the sensor output and the input on the board. The red boxes with white switches shown in the picture below provide a way to change that resistive value from 0 to 155 Ohms. There are three 40 Ohm resistors, one 20 Ohm, one 10 Ohm and one 5 Ohm resistors. These resistors are connected by the switching devices in series. With switches 2 and 3 in the off position $R_M = 60$ Ohms of resistance, this provides a value that is suitable for all operations of the LA 55-P.
 - a. The switch labeled 1 controls 80 Ohms of resistance
 - b. The switch labeled 2 controls 40 Ohms of resistance
 - c. The switch labeled 3 controls 20 Ohms of resistance
 - d. The switch labeled 4 controls 10 Ohms of resistance

e. The switch labeled 5 controls 5 Ohms of resistance

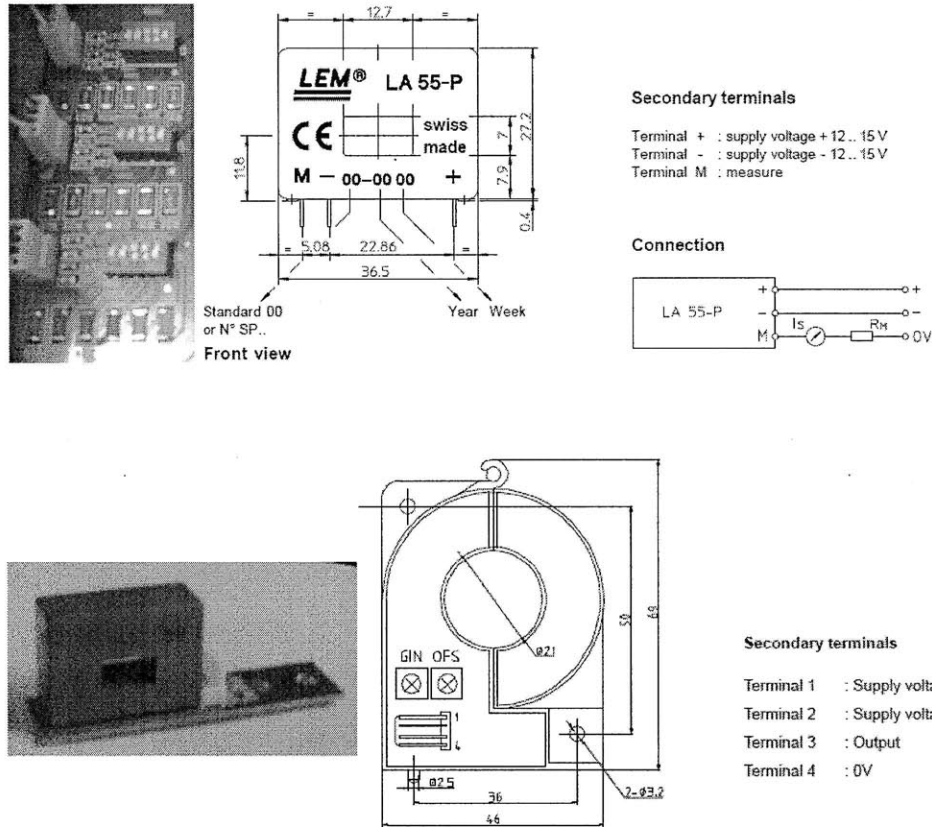

** Note: If the HTR 50-SB is used, the output is a voltage and does not require any resistive element. To use the HTR 50-SB current sensor all of the switches 1-5 should be in the ON position. A slight modification to the cable is also required. Currently the current sensor cable is set up to take the output on pin 1, provide -12V on pin 2, provide +12V on pin 3 and provide the ground on pin 4. The HTR 50-SB is configured to provide +12V on pin 1, provide -12V on pin 2, take the output on pin 3, and provide a ground on pin 4.

APPENDIX II – Contactor and SSR Controller Code

```
function varargout = zeds_gui_v3(varargin)
% ZEDS_GUI_V3 M-file for zeds_gui_v3.fig
%   ZEDS_GUI_V3, by itself, creates a new ZEDS_GUI_V3 or raises the existing
%   singleton*.
%
%   H = ZEDS_GUI_V3 returns the handle to a new ZEDS_GUI_V3 or the handle to
%   the existing singleton*.
%
%   ZEDS_GUI_V3('CALLBACK',hObject,eventData,handles,...) calls the local
%   function named CALLBACK in ZEDS_GUI_V3.M with the given input arguments.
%
%   ZEDS_GUI_V3('Property','Value',...) creates a new ZEDS_GUI_V3 or raises the
%   existing singleton*. Starting from the left, property value pairs are
%   applied to the GUI before zeds_gui_v3_OpeningFcn gets called. An
%   unrecognized property name or invalid value makes property application
%   stop. All inputs are passed to zeds_gui_v3_OpeningFcn via varargin.
%
%   *See GUI Options on GUIDE's Tools menu. Choose "GUI allows only one
%   instance to run (singleton)".
%
% See also: GUIDE, GUIDATA, GUIHANDLES

% Edit the above text to modify the response to help zeds_gui_v3

% Last Modified by GUIDE v2.5 12-May-2010 19:25:52

% Begin initialization code - DO NOT EDIT
gui_Singleton = 1;
gui_State = struct('gui_Name',    mfilename, ...
                  'gui_Singleton', gui_Singleton, ...
                  'gui_OpeningFcn', @zeds_gui_v3_OpeningFcn, ...
                  'gui_OutputFcn', @zeds_gui_v3_OutputFcn, ...
                  'gui_LayoutFcn', [] , ...
                  'gui_Callback', []);
if nargin && ischar(varargin{1})
    gui_State.gui_Callback = str2func(varargin{1});
end

if nargout
    [varargout{1:nargout}] = gui_mainfcn(gui_State, varargin{:});
else
    gui_mainfcn(gui_State, varargin{:});
end
```

```

end
% End initialization code - DO NOT EDIT
end

% --- Executes just before zeds_gui_v3 is made visible.
function zeds_gui_v3_OpeningFcn(hObject, eventdata, handles, varargin)
% This function has no output args, see OutputFcn.
% hObject    handle to figure
% eventdata  reserved - to be defined in a future version of MATLAB
% handles    structure with handles and user data (see GUIDATA)
% varargin   command line arguments to zeds_gui_v3 (see VARARGIN)

% Choose default command line output for zeds_gui_v3
handles.output = hObject;

% Update handles structure
guidata(hObject, handles);

% UIWAIT makes zeds_gui_v3 wait for user response (see UIRESUME)
% uiwait(handles.figure1);
end

% --- Outputs from this function are returned to the command line.
function varargout = zeds_gui_v3_OutputFcn(hObject, eventdata, handles)
% varargout  cell array for returning output args (see VARARGOUT);
% hObject    handle to figure
% eventdata  reserved - to be defined in a future version of MATLAB
% handles    structure with handles and user data (see GUIDATA)

% Get default command line output from handles structure
varargout{1} = handles.output;
end

% Written by Jim Paris at MIT 4/23/2010
function pic_send(s, data)
    if (mod(length(data), 4) ~= 0)
        error('length of data must be a multiple of 4');
    end
    for i = 1 : 4 : length(data)
        if (i < length(data) - 4)
            command = '0001'; % write, but don't latch

```

```

    else
        command = '0101'; % write and latch
    end
    val = bin2dec([command char(data(i:i+3)+'0')]);
    fprintf(1, 'writing 0x%02x\n', val);
    fwrite(s, val);
end
end

function togglebutton1_Callback(hObject, eventdata, handles)
    button_state = get(hObject, 'Value');
    global s;
    global status;

    if button_state == get(hObject, 'Max')
        % Toggle button is pressed, take appropriate action
        status(1) = 1;
        pic_send(s, status);
    elseif button_state == get(hObject, 'Min')
        % Toggle button is not pressed, take appropriate action
        status(1) = 0;
        pic_send(s, status);
    end
    updateGUI(handles);
end

function togglebutton2_Callback(hObject, eventdata, handles)
    button_state = get(hObject, 'Value');
    global s;
    global status;

    if button_state == get(hObject, 'Max')
        % Toggle button is pressed, take appropriate action
        status(2) = 1;
        pic_send(s, status);
    elseif button_state == get(hObject, 'Min')
        % Toggle button is not pressed, take appropriate action
        status(2) = 0;
        pic_send(s, status);
    end
    updateGUI(handles);
end

function togglebutton3_Callback(hObject, eventdata, handles)

```

```

button_state = get(hObject,'Value');
global s;
global status;

if button_state == get(hObject,'Max')
    % Toggle button is pressed, take appropriate action
    status(3)=1;
    pic_send(s,status);
elseif button_state == get(hObject,'Min')
    % Toggle button is not pressed, take appropriate action
    status(3)=0;
    pic_send(s,status);
end
updateGUI(handles);
end

function togglebutton16_Callback(hObject, eventdata, handles)
global s;
global status;
button_state = get(hObject,'Value');

if button_state == get(hObject,'Max')
    % Toggle button is pressed, take appropriate action
    status(16)=1;
    pic_send(s,status);
elseif button_state == get(hObject,'Min')
    % Toggle button is not pressed, take appropriate action
    status(16)=0;
    pic_send(s,status);
end
updateGUI(handles);
end

function togglebutton15_Callback(hObject, eventdata, handles)
global s;
global status;
button_state = get(hObject,'Value');

if button_state == get(hObject,'Max')
    % Toggle button is pressed, take appropriate action
    status(15)=1;
    pic_send(s,status);
elseif button_state == get(hObject,'Min')

```

```

    % Toggle button is not pressed, take appropriate action
    status(15)=0;
    pic_send(s,status);
end
updateGUI(handles);
end

```

```

function togglebutton4_Callback(hObject, eventdata, handles)
    global s;
    global status;
    button_state = get(hObject,'Value');

    if button_state == get(hObject,'Max')
        % Toggle button is pressed, take appropriate action
        status(4)=1;
        pic_send(s,status);
    elseif button_state == get(hObject,'Min')
        % Toggle button is not pressed, take appropriate action
        status(4)=0;
        pic_send(s,status);
    end
    updateGUI(handles);
end

```

```

function togglebutton5_Callback(hObject, eventdata, handles)
    global s;
    global status;
    button_state = get(hObject,'Value');

    if button_state == get(hObject,'Max')
        % Toggle button is pressed, take appropriate action
        status(5)=1;
        pic_send(s,status);
    elseif button_state == get(hObject,'Min')
        % Toggle button is not pressed, take appropriate action
        status(5)=0;
        pic_send(s,status);
    end
    updateGUI(handles);
end

```

```

function togglebutton6_Callback(hObject, eventdata, handles)
    global s;
    global status;
    button_state = get(hObject,'Value');

    if button_state == get(hObject,'Max')
        % Toggle button is pressed, take appropriate action
        status(6)=1;
        pic_send(s,status);
    elseif button_state == get(hObject,'Min')
        % Toggle button is not pressed, take appropriate action
        status(6)=0;
        pic_send(s,status);
    end
    updateGUI(handles);
end

```

```

function togglebutton7_Callback(hObject, eventdata, handles)
    global s;
    global status;
    button_state = get(hObject,'Value');

    if button_state == get(hObject,'Max')
        % Toggle button is pressed, take appropriate action
        status(7)=1;
        pic_send(s,status);
    elseif button_state == get(hObject,'Min')
        % Toggle button is not pressed, take appropriate action
        status(7)=0;
        pic_send(s,status);
    end
    updateGUI(handles);
end

```

```

function togglebutton8_Callback(hObject, eventdata, handles)
    global s;
    global status;
    button_state = get(hObject,'Value');

    if button_state == get(hObject,'Max')
        % Toggle button is pressed, take appropriate action
        status(8)=1;
        pic_send(s,status);
    end

```



```

elseif button_state == get(hObject,'Min')
    % Toggle button is not pressed, take appropriate action
    status(8)=0;
    pic_send(s,status);
end
updateGUI(handles);
end

function togglebutton9_Callback(hObject, eventdata, handles)
    global s;
    global status;
    button_state = get(hObject,'Value');

    if button_state == get(hObject,'Max')
        % Toggle button is pressed, take appropriate action
        status(9)=1;
        pic_send(s,status);
    elseif button_state == get(hObject,'Min')
        % Toggle button is not pressed, take appropriate action
        status(9)=0;
        pic_send(s,status);
    end
    updateGUI(handles);
end

function togglebutton10_Callback(hObject, eventdata, handles)
    global s;
    global status;
    button_state = get(hObject,'Value');

    if button_state == get(hObject,'Max')
        % Toggle button is pressed, take appropriate action
        status(10)=1;
        pic_send(s,status);
    elseif button_state == get(hObject,'Min')
        % Toggle button is not pressed, take appropriate action
        status(10)=0;
        pic_send(s,status);
    end
    updateGUI(handles);
end

function togglebutton11_Callback(hObject, eventdata, handles)
    button_state = get(hObject,'Value');

```

```

if button_state == get(hObject,'Max')
    % Toggle button is pressed, take appropriate action
    disp('Not currently in use');
elseif button_state == get(hObject,'Min')
    % Toggle button is not pressed, take appropriate action
    disp('Not currently in use');
end
end

function togglebutton12_Callback(hObject, eventdata, handles)
    button_state = get(hObject,'Value');
    if button_state == get(hObject,'Max')
        % Toggle button is pressed, take appropriate action
        disp('Not currently in use');
    elseif button_state == get(hObject,'Min')
        % Toggle button is not pressed, take appropriate action
        disp('Not currently in use');
    end
end

function togglebutton13_Callback(hObject, eventdata, handles)
    global s;
    global status;
    button_state = get(hObject,'Value');

    if button_state == get(hObject,'Max')
        % Toggle button is pressed, take appropriate action
        status(13)=1;
        pic_send(s,status);
    elseif button_state == get(hObject,'Min')
        % Toggle button is not pressed, take appropriate action
        status(13)=0;
        pic_send(s,status);
    end
    updateGUI(handles);
end

function togglebutton14_Callback(hObject, eventdata, handles)
    global s;
    global status;
    button_state = get(hObject,'Value');

    if button_state == get(hObject,'Max')
        % Toggle button is pressed, take appropriate action

```

```

        status(14)=1;
        pic_send(s,status);
    elseif button_state == get(hObject,'Min')
        % Toggle button is not pressed, take appropriate action
        status(14)=0;
        pic_send(s,status);
    end
    updateGUI(handles);
end

```

```

% --- Executes on button press in pushbutton1.
function pushbutton23_Callback(hObject, eventdata, handles)
% hObject    handle to pushbutton1 (see GCBO)
% eventdata  reserved - to be defined in a future version of MATLAB
% handles    structure with handles and user data (see GUIDATA)
global s;
global status;
status(1:16)=0;
pic_send(s,status);

```

```

set(handles.togglebutton1,'Value',0);
set(handles.togglebutton2,'Value',0);
set(handles.togglebutton3,'Value',0);
set(handles.togglebutton4,'Value',0);
set(handles.togglebutton5,'Value',0);
set(handles.togglebutton6,'Value',0);
set(handles.togglebutton7,'Value',0);
set(handles.togglebutton8,'Value',0);
set(handles.togglebutton9,'Value',0);
set(handles.togglebutton10,'Value',0);
set(handles.togglebutton13,'Value',0);
set(handles.togglebutton14,'Value',0);
set(handles.togglebutton15,'Value',0);
set(handles.togglebutton16,'Value',0);

```

```

    updateGUI(handles);
end

```

```

% --- Executes on button press in pushbutton1.
function pushbutton24_Callback(hObject, eventdata, handles)
% hObject    handle to pushbutton1 (see GCBO)
% eventdata  reserved - to be defined in a future version of MATLAB
% handles    structure with handles and user data (see GUIDATA)
global s;

```

```

global status;

set(handles.togglebutton1,'Value',1);
set(handles.togglebutton2,'Value',1);
set(handles.togglebutton3,'Value',1);
set(handles.togglebutton4,'Value',0);
set(handles.togglebutton5,'Value',0);
set(handles.togglebutton6,'Value',1);
set(handles.togglebutton7,'Value',1);
set(handles.togglebutton8,'Value',1);
set(handles.togglebutton9,'Value',1);
set(handles.togglebutton10,'Value',1);
set(handles.togglebutton13,'Value',1);
set(handles.togglebutton14,'Value',1);
set(handles.togglebutton15,'Value',1);
set(handles.togglebutton16,'Value',1);

status(1:3)=1;
status(4:5)=0;
status(6:10)=1;
status(11:12)=0;
status(13:16)=1;

pic_send(s,status);
updateGUI(handles);
end

% --- Executes on button press in pushbutton25.
function pushbutton25_Callback(hObject, eventdata, handles)
% hObject    handle to pushbutton25 (see GCBO)
% eventdata  reserved - to be defined in a future version of MATLAB
% handles    structure with handles and user data (see GUIDATA)
global s status;
status(1:16)=0;

set(handles.togglebutton1,'Value',0);
set(handles.togglebutton2,'Value',0);
set(handles.togglebutton3,'Value',0);
set(handles.togglebutton4,'Value',0);
set(handles.togglebutton5,'Value',0);
set(handles.togglebutton6,'Value',0);
set(handles.togglebutton7,'Value',0);
set(handles.togglebutton8,'Value',0);

```

```
set(handles.togglebutton9,'Value',0);
set(handles.togglebutton10,'Value',0);
set(handles.togglebutton13,'Value',0);
set(handles.togglebutton14,'Value',0);
set(handles.togglebutton15,'Value',0);
set(handles.togglebutton16,'Value',0);
```

```
s=pic_open('COM3');
set(handles.radiobutton2,'Value',1);
set(handles.radiobutton3,'Value',0);
pic_send(s,status);
```

```
updateGUI(handles);
```

```
end
```

```
% --- Executes on button press in radiobutton2.
function radiobutton2_Callback(hObject, eventdata, handles)
% hObject handle to radiobutton2 (see GCBO)
% eventdata reserved - to be defined in a future version of MATLAB
% handles structure with handles and user data (see GUIDATA)
global s status;
s=pic_open('COM3');
status(1:16)=0;
pic_send(s,status);

set(handles.radiobutton3,'Value',0);
set(handles.togglebutton1,'Value',0);
set(handles.togglebutton2,'Value',0);
set(handles.togglebutton3,'Value',0);
set(handles.togglebutton4,'Value',0);
set(handles.togglebutton5,'Value',0);
set(handles.togglebutton6,'Value',0);
set(handles.togglebutton7,'Value',0);
set(handles.togglebutton8,'Value',0);
set(handles.togglebutton9,'Value',0);
set(handles.togglebutton10,'Value',0);
set(handles.togglebutton13,'Value',0);
set(handles.togglebutton14,'Value',0);
set(handles.togglebutton15,'Value',0);
set(handles.togglebutton16,'Value',0);
% Hint: get(hObject,'Value') returns toggle state of radiobutton2
```

```
    updateGUI(handles);  
end
```

```
% --- Executes on button press in radiobutton3.  
function radiobutton3_Callback(hObject, eventdata, handles)  
% hObject    handle to radiobutton3 (see GCBO)  
% eventdata reserved - to be defined in a future version of MATLAB  
% handles    structure with handles and user data (see GUIDATA)  
    global s status;  
  
    status(1:16)=0;  
    pic_send(s,status);  
  
    set(handles.radiobutton2,'Value',0);  
    set(handles.togglebutton1,'Value',0);  
    set(handles.togglebutton2,'Value',0);  
    set(handles.togglebutton3,'Value',0);  
    set(handles.togglebutton4,'Value',0);  
    set(handles.togglebutton5,'Value',0);  
    set(handles.togglebutton6,'Value',0);  
    set(handles.togglebutton7,'Value',0);  
    set(handles.togglebutton8,'Value',0);  
    set(handles.togglebutton9,'Value',0);  
    set(handles.togglebutton10,'Value',0);  
    set(handles.togglebutton13,'Value',0);  
    set(handles.togglebutton14,'Value',0);  
    set(handles.togglebutton15,'Value',0);  
    set(handles.togglebutton16,'Value',0);  
  
    opened = instrfind('Port','COM3');  
    fclose(opened);  
  
    % Hint: get(hObject,'Value') returns toggle state of radiobutton3  
    updateGUI(handles);  
end
```

```
% --- Executes on button press in pushbutton26.  
function pushbutton26_Callback(hObject, eventdata, handles)  
% hObject    handle to pushbutton26 (see GCBO)  
% eventdata reserved - to be defined in a future version of MATLAB  
% handles    structure with handles and user data (see GUIDATA)  
    global s status;
```

```

status(1:16)=0;
pic_send(s,status);

set(handles.togglebutton1,'Value',0);
set(handles.togglebutton2,'Value',0);
set(handles.togglebutton3,'Value',0);
set(handles.togglebutton4,'Value',0);
set(handles.togglebutton5,'Value',0);
set(handles.togglebutton6,'Value',0);
set(handles.togglebutton7,'Value',0);
set(handles.togglebutton8,'Value',0);
set(handles.togglebutton9,'Value',0);
set(handles.togglebutton10,'Value',0);
set(handles.togglebutton13,'Value',0);
set(handles.togglebutton14,'Value',0);
set(handles.togglebutton15,'Value',0);
set(handles.togglebutton16,'Value',0);

set(handles.radiobutton2,'Value',0);
set(handles.radiobutton3,'Value',1);

opened = instrfind('Port','COM3');
fclose(opened);

updateGUI(handles);
end

```

```

function updateGUI(handles)
global status;
SG1 = status(1);
XT1A = status(2);
XT1B = status(3);
LTA = status(4);
LTB = status(5);
XTABT2A = status(6);
XTABT2B = status(7);
XT3A = status(8);
XT3B = status(9);
SG3 = status(10);
LC3A = status(13);
LC3B = status(14);
LC1A = status(15);
LC1B = status(16);

```

```

nodecolor1 = zeros(size(status));
nodecolor3 = zeros(size(status));

nodecolor1(5) = 1;
nodecolor3(13) = 1;

if(SG1)
    nodecolor1(1) = 1;
    nodecolor1(2) = XT1A | (XT1B & LTB & XT3B & XT3A & LTA);
    nodecolor1(3) = XT1B | (XT1A & LTA & XT3A & XT3B & LTB);
    nodecolor1(7) = (XT1A & LTA & XT3A) | (XT1B & LTB & XT3B);
    nodecolor1(8) = (XT1A & LTA) | (XT1B & LTB & XT3B & XT3A);
    nodecolor1(9) = (XT1B & LTB) | (XT1A & LTA & XT3A & XT3B);
    nodecolor1(4) = nodecolor1(3) & LC1B;
    nodecolor1(6) = nodecolor1(2) & LC1A;
    nodecolor1(10) = nodecolor1(9) & LC3B;
    nodecolor1(13) = nodecolor1(7) & SG3;
    nodecolor1(14) = nodecolor1(8) & LC3A;
    nodecolor1(15) = nodecolor1(9) & XTABT2B;
    nodecolor1(16) = nodecolor1(8) & XTABT2A;
end

if(SG3)
    nodecolor3(1) = (XT3A & LTA & XT1A) | (XT3B & LTB & XT1B);
    nodecolor3(2) = (XT3A & LTA) | (XT3B & LTB & XT1B & XT1A);
    nodecolor3(3) = (XT3B & LTB) | (XT3A & LTA & XT1A & XT1B);
    nodecolor3(7) = 1;
    nodecolor3(8) = XT3A | (XT3B & LTB & XT1B & XT1A & LTA);
    nodecolor3(9) = XT3B | (XT3A & LTA & XT1A & XT1B & LTB);
    nodecolor3(4) = nodecolor3(3) & LC1B;
    nodecolor3(5) = nodecolor3(1) & SG1;
    nodecolor3(6) = nodecolor3(2) & LC1A;
    nodecolor3(10) = nodecolor3(9) & LC3B;
    nodecolor3(14) = nodecolor3(8) & LC3A;
    nodecolor3(15) = nodecolor3(9) & XTABT2B;
    nodecolor3(16) = nodecolor3(8) & XTABT2A;
end

texts = { {'2','3','4','5'},...
          {'9','10'},...
          {'6','7'},...
          {'8'},...
          {'1'},...

```



```

{'11'},...
{'23','24','25','26'},...
{'12','13','22'},...
{'16','17','18'},...
{'19'},...
{},...
{},...
{'20'},...
{'21'},...
{'15'},...
{'14'},...
};

```

```

for k=1:length(status)
    color = [+nodecolor1(k) 0 +nodecolor3(k)];

    if(sum(color) == 0)
        color = [1 1 1];
    end

    text = texts{k};
    for m=1:length(text)
        eval(strcat(['tb = handles.text',text{m},','']));
        set(tb,'BackgroundColor',color);
    end

end

end
end

```

APPENDIX III - Control Systems Overview

Electrical generation systems require the use of automated control systems to maintain proper voltage and frequency levels in the face of dynamic load changes. This section is provided as a basic introduction to control systems in order to provide a frame of reference when control systems are discussed later in this thesis. There are three classical types of control systems non-feedback, feed forward, and feedback each will be discussed in the following sections.

Non-Feedback

A non-feedback controller, commonly called an open loop controller is the simplest form of controller; a command is given and followed out until a new command is generated. A basic representation is shown below in Figure 58. Typically this type of control method is not used in autonomous systems since there is no way for the system to react to a disturbance or unexpected event.

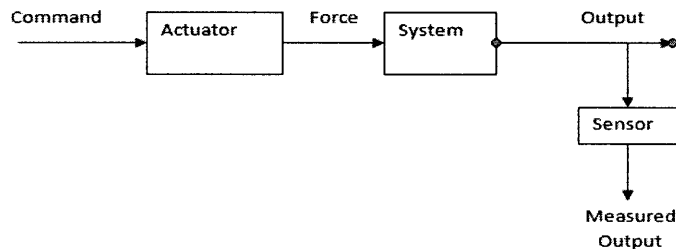

Figure 58: Open Loop Controller

Feed-Forward

This type of control system is similar to an open loop system in that there is no feedback loop. However, it is different from an open loop system because it has the ability to compensate for or react to external disturbances as determined by the controller designer. In order to compensate for the external disturbances, the effect the disturbance has on the system must be well understood and repeatable/predictable. A simple depiction of a feed-forward controller is shown below in Figure 59. If this type of system was implemented in a car cruise

control system an external sensor of might be implemented to determine, let say wind velocity, and based on that information the vehicle would compensate for the effect of wind velocity on the speed of the vehicle. For multiple reasons this would not be a practical controller for a car cruise control, this is particularly true when a relatively simple feedback controller can offer much better control with the same or substantially less complexity.

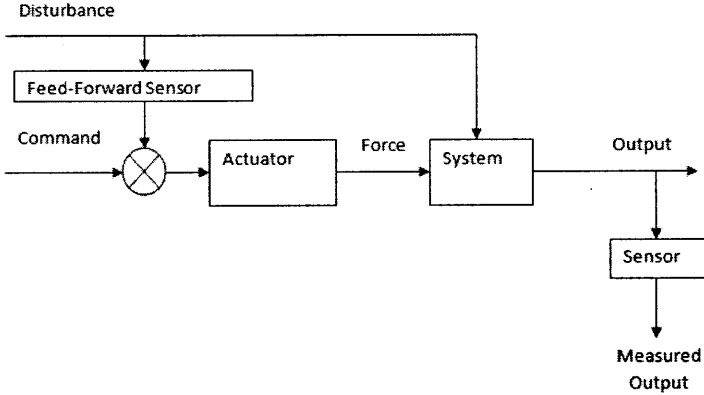

Figure 59: Feed-Forward Controller

Feedback

Also called closed loop control, this is the most common form of control system used in industry. An example of a basic feedback controller is shown below in Figure 60. There are multiple types of control parameters that can be incorporated into a feedback controller.

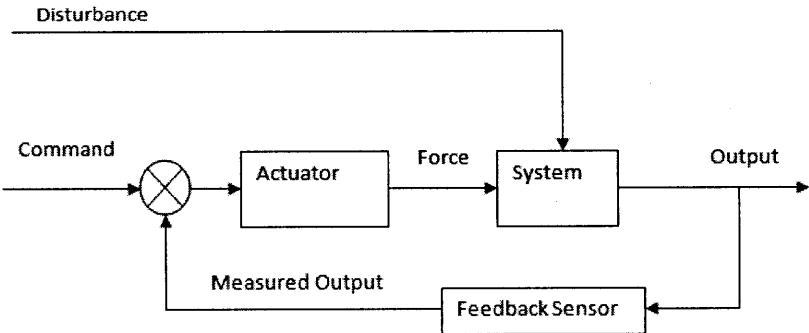

Figure 60: Closed Loop Controller

The most common form of closed loop controller in industry is the Proportional Integral Derivative (PID) controller. These three terms are described below.

1. Proportional – This term uses the current error, the difference between the command and the actual output, to produce a proportional signal to drive the system to the desired output. The primary characteristic associated with the proportional term is responsiveness, if the system is too responsive or not responsive enough the system can be unstable. Additionally this term produces offset; a consistent discrepancy between the command and the output, commonly referred to as droop.
2. Integral – This term sums the instantaneous error over time to determine the integral of the error. This error is the offset over time that needs to be corrected for in order to prevent droop and achieve the desired command. The drawback being overshoot which will lead to hunting or oscillation around the commanded value. This is one common way to improve a purely proportional controller.
3. Derivative – This term uses the slope of the error to compensate for the overshoot and is particularly useful as the system output gets close to the commanded value as it measures the rate of approach. The drawback is sensitivity to noise in the system dependant on the gain associated with this term. As a result it is common to employ some type of filtering when using a derivative term and or an approximate derivative with a limited bandwidth.

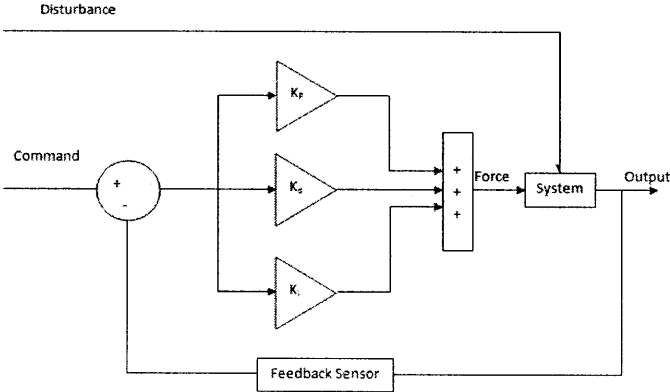

Figure 61: A Closed Loop PID Controller

In the case of this type of controller, the ability to compare the desired response with the actual response makes this a particularly powerful controller that is fairly intuitive to create and use.

Table 7, shows how adjusting the controller terms effects the rise time, overshoot, settling time and S-S error.

Table 7: PID Term Adjustment Affects⁴

The effects of increasing each of the controller parameters K_P , K_I and K_D can be summarized as

Response	Rise Time	Overshoot	Settling Time	S-S Error
K_P	Decrease	Increase	NT	Decrease
K_I	Decrease	Increase	Increase	Eliminate
K_D	NT	Decrease	Decrease	NT

NT: No definite trend. Minor change.

⁴ 2.154 lecture notes

APPENDIX IV – System Modeling

High Level System Architecture

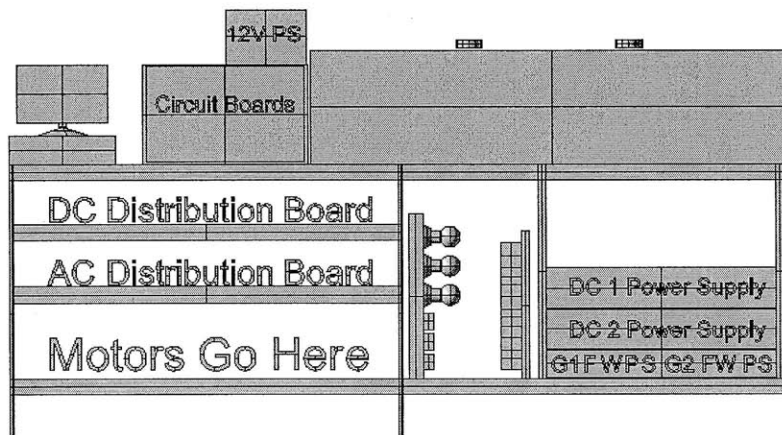
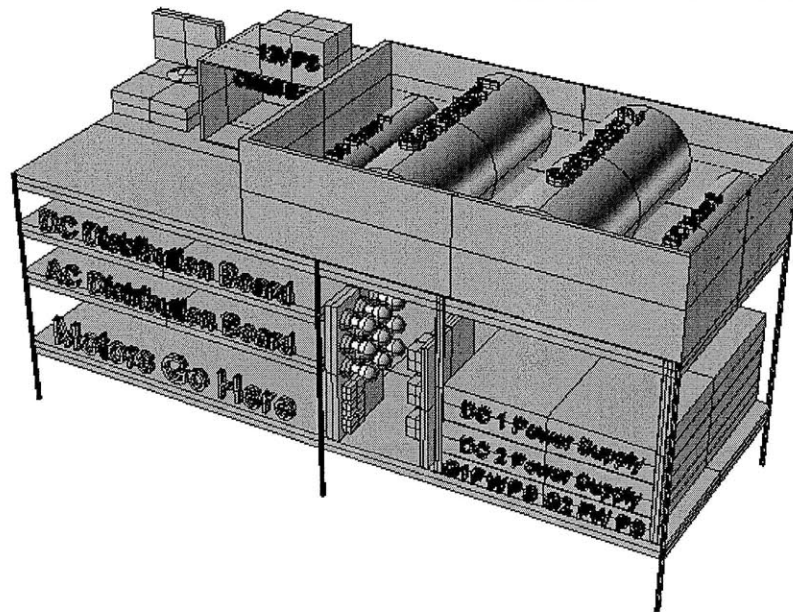
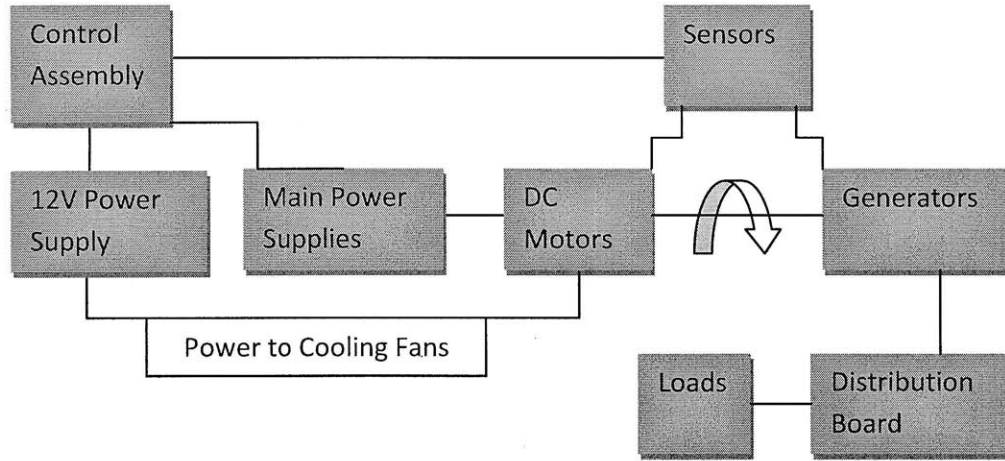

The Circuit Board Architectures

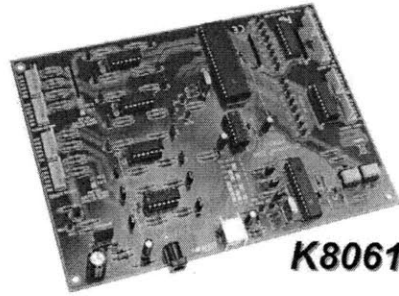

USB Board Schematic

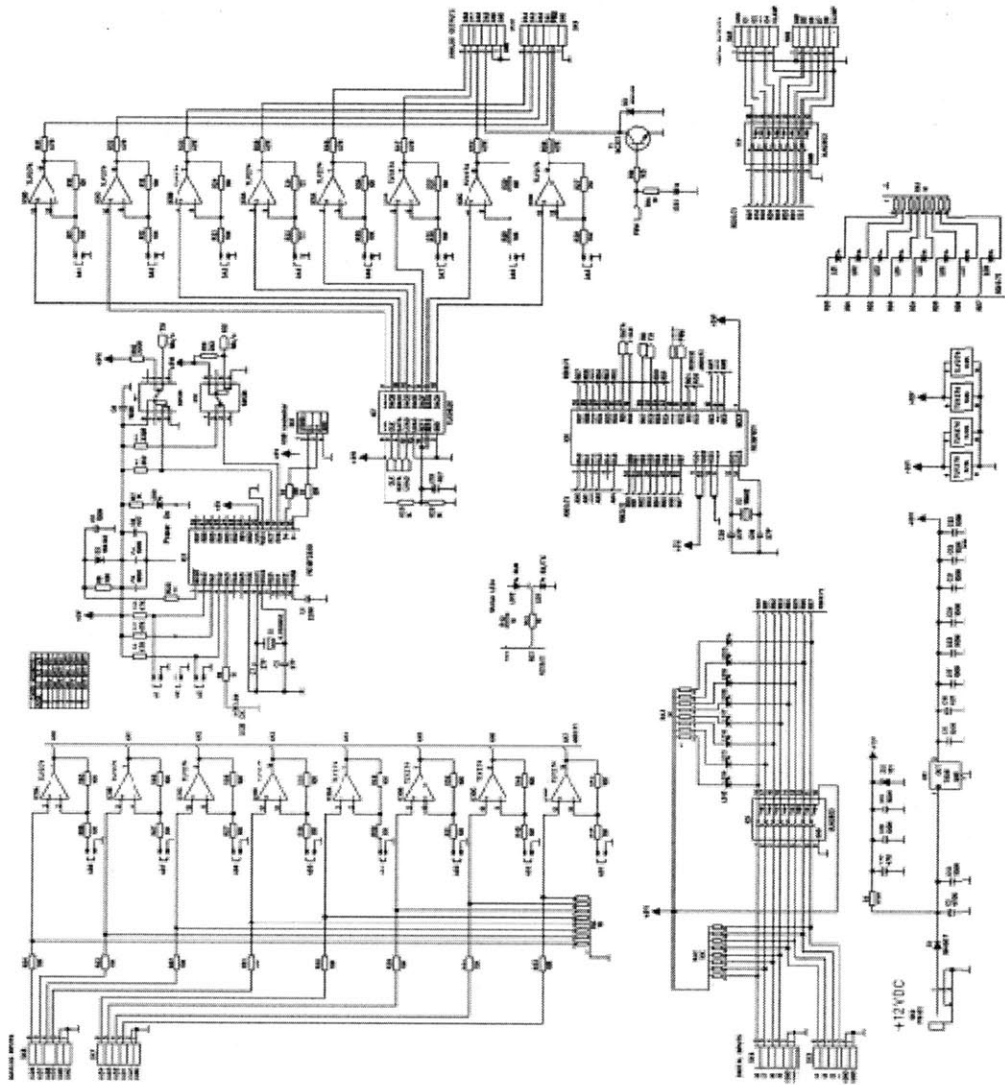

Rachel's OpAmp/Cycle Counting Board

Connections

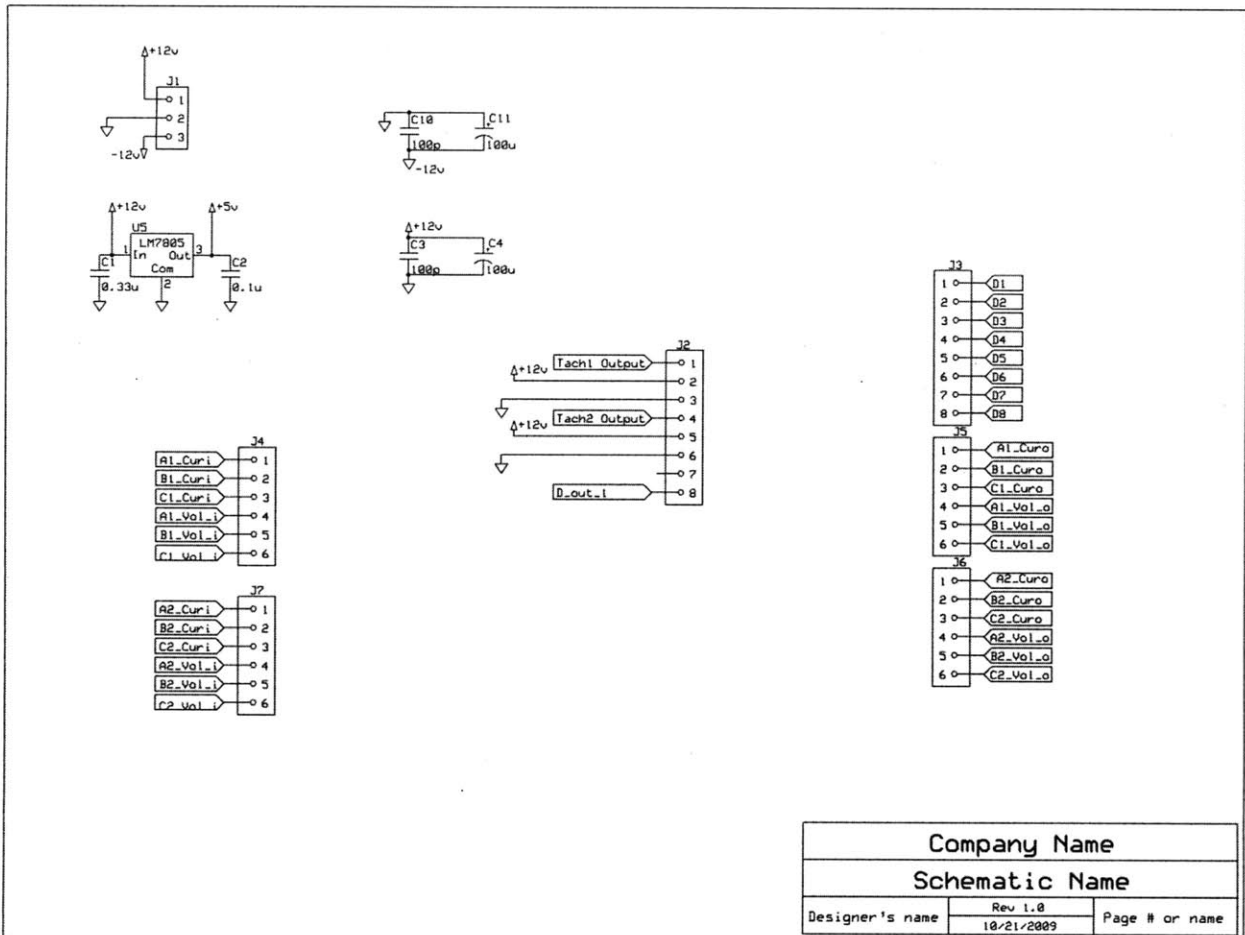

Company Name		
Schematic Name		
Designer's name	Rev 1.8 10/21/2009	Page # or name

Cycle Counting Sensor

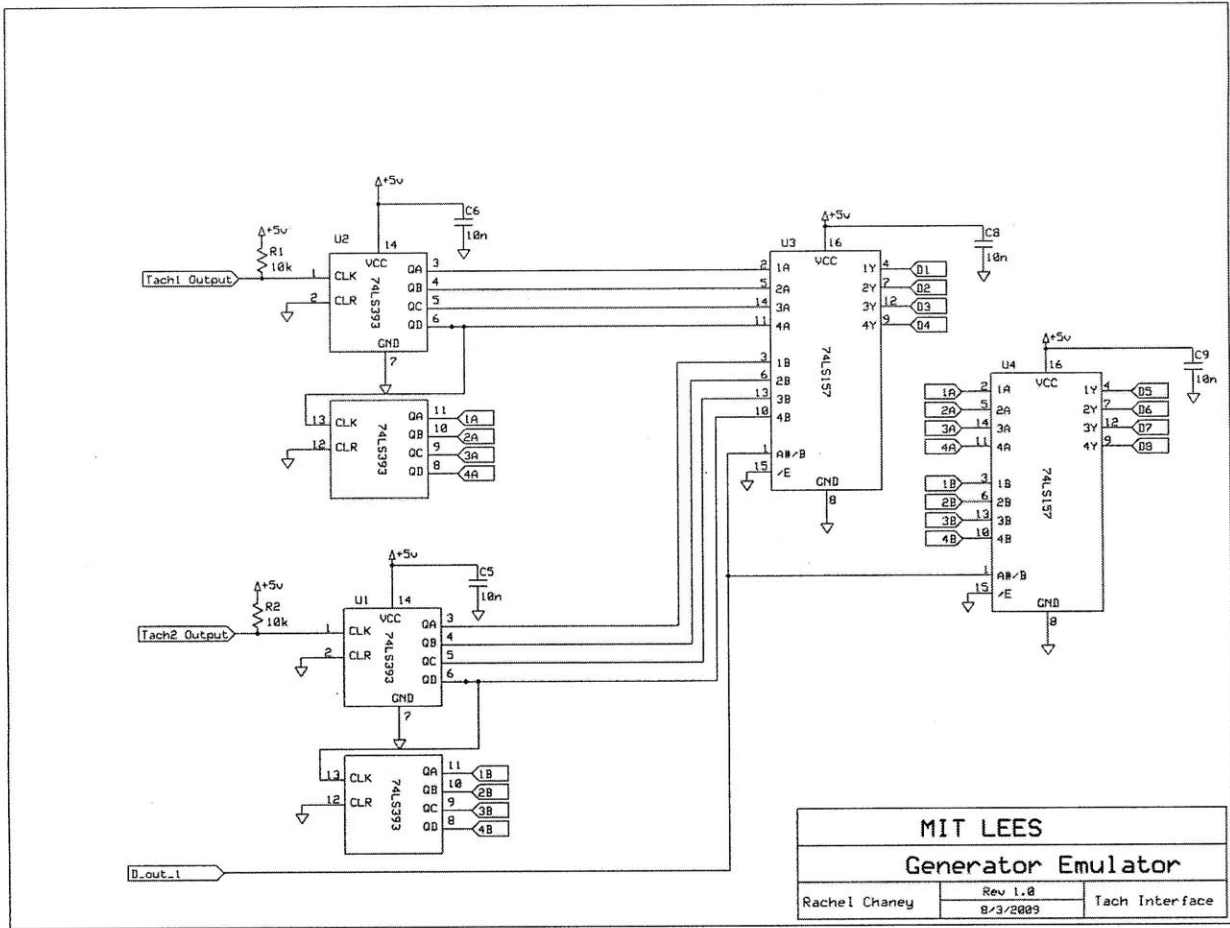

Level Shifting OpAmps for Generator 1

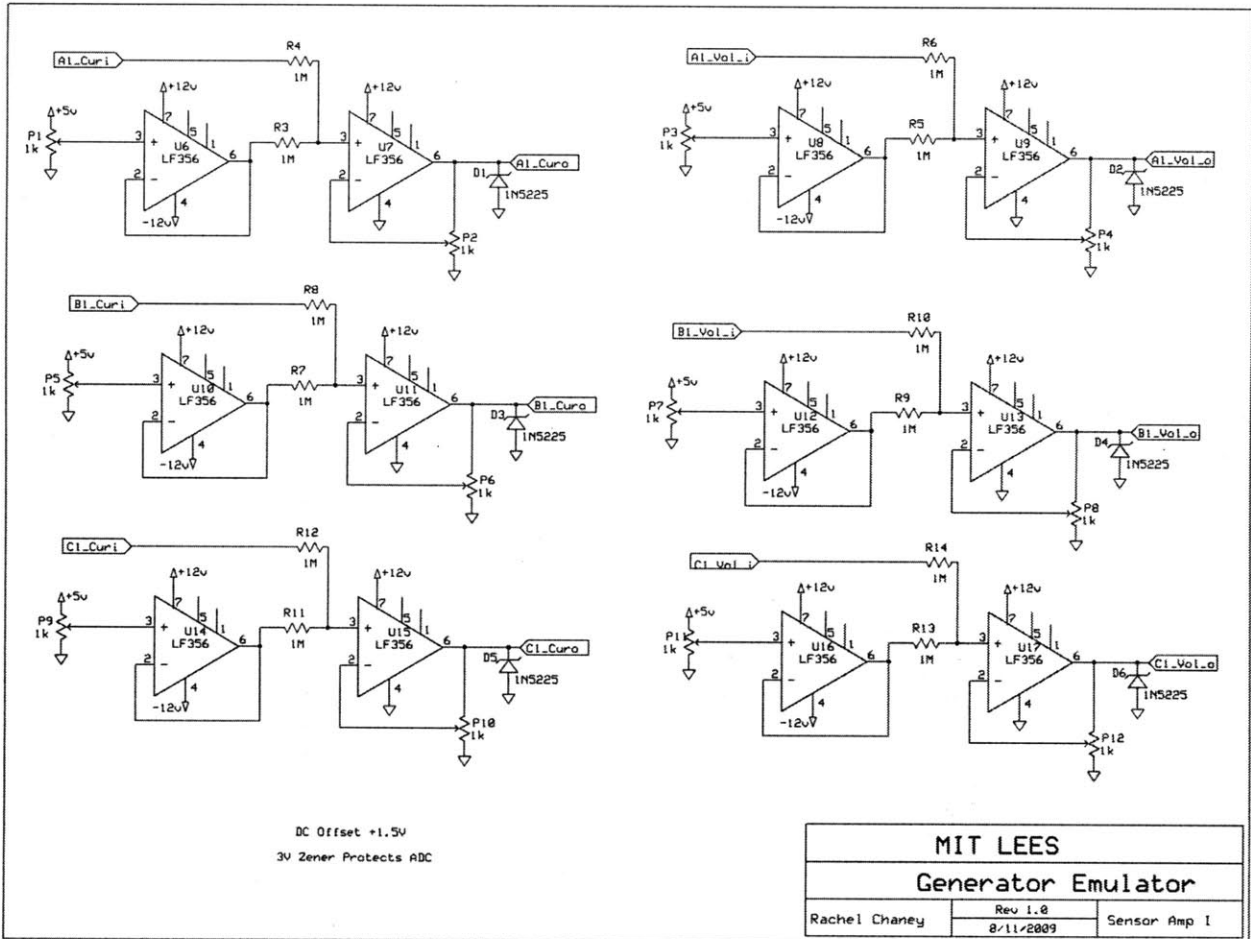

Level Shifting OpAmps for Generator 2

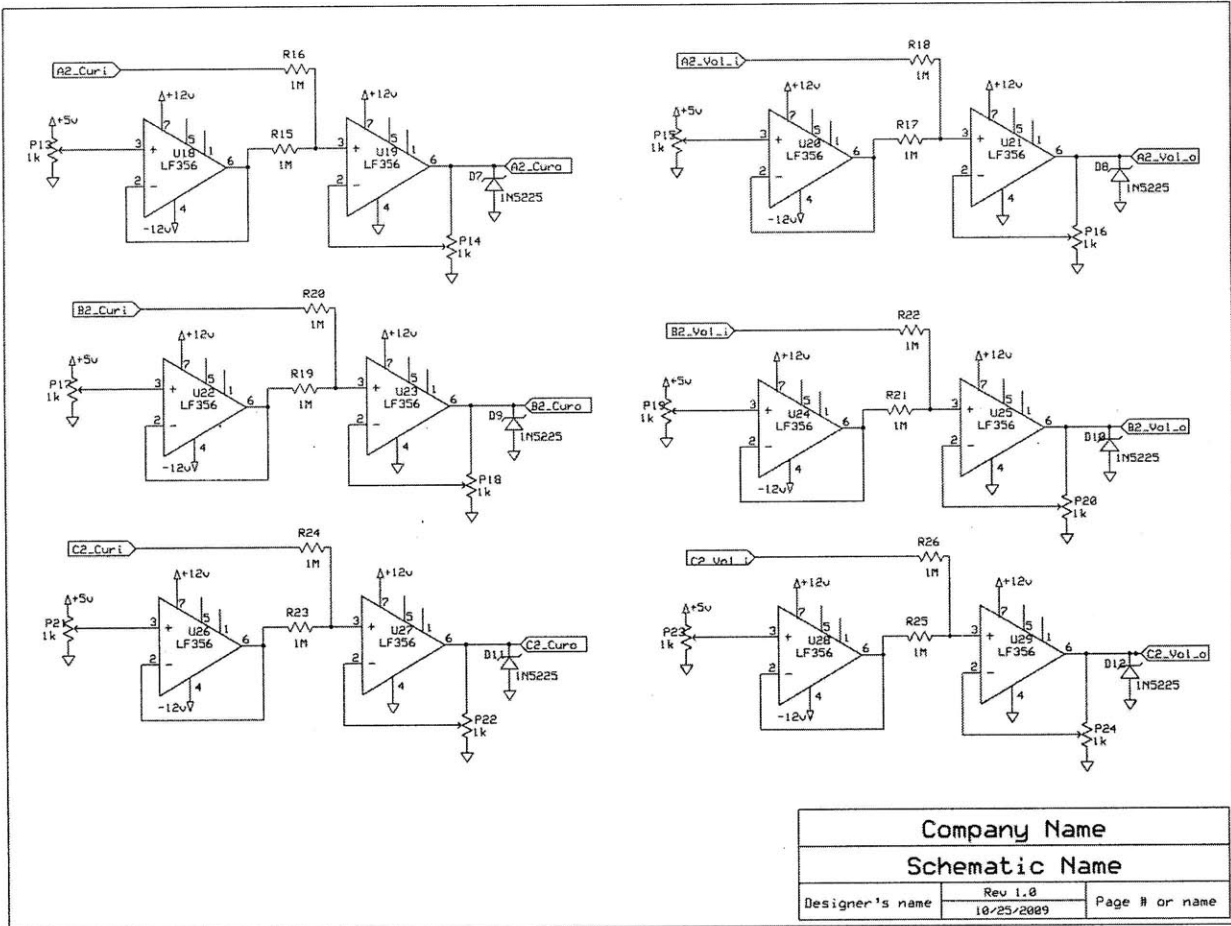

Voltage and Current Sensor Board

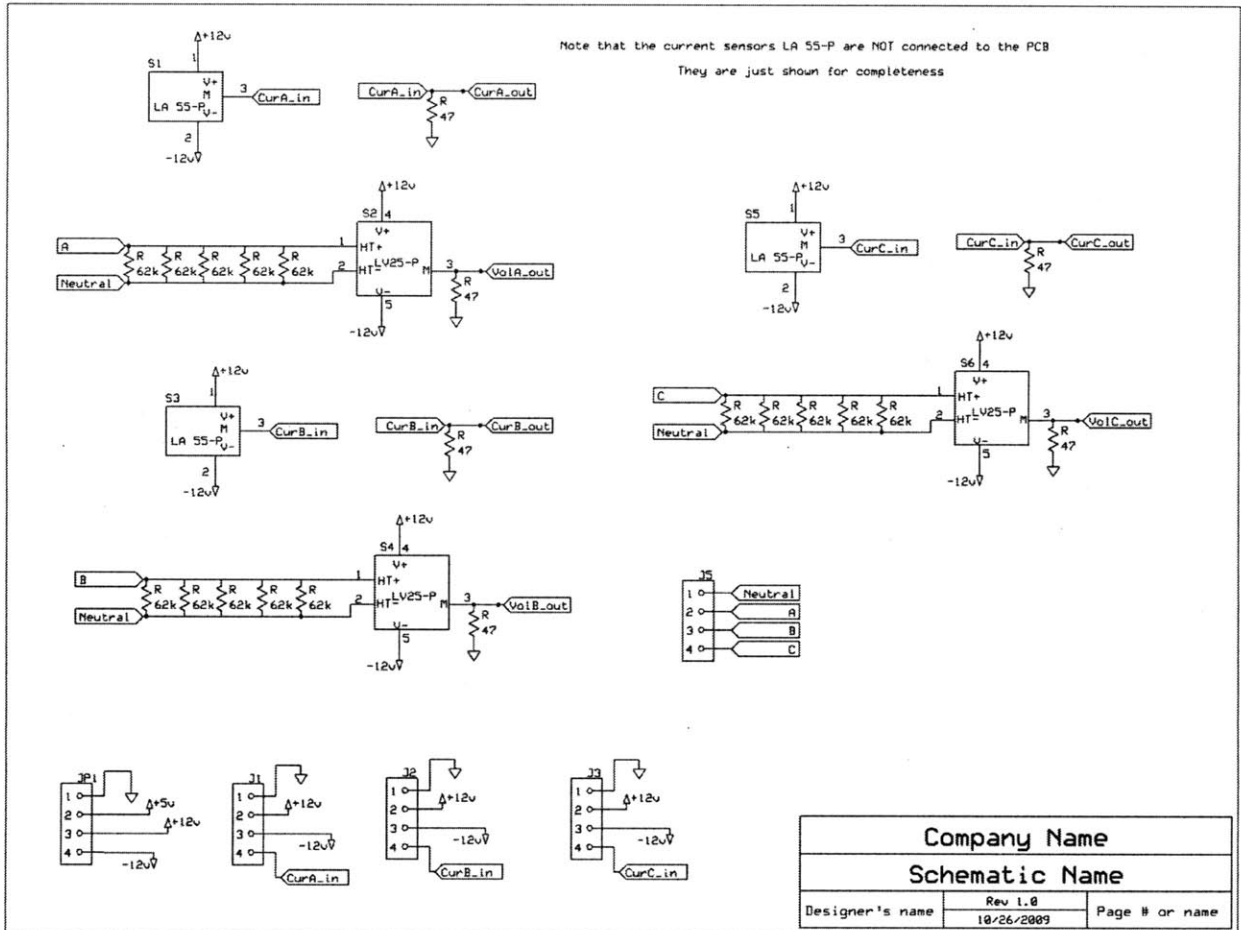

The Detailed System Layout

Note: Red dotted line indicates a Mechanical Connection (belt drive) between the DC motors and the Generators.

