

MIT Open Access Articles

A Wearable Sensor for Unobtrusive, Long-Term Assessment of Electrodermal Activity

The MIT Faculty has made this article openly available. **Please share** how this access benefits you. Your story matters.

Citation: Swenson, N.C., and R.W. Picard, with Ming-Zher Poh. "A Wearable Sensor for Unobtrusive, Long-Term Assessment of Electrodermal Activity." *Biomedical Engineering, IEEE Transactions On* 57.5 (2010) : 1243-1252. Copyright © 2010, IEEE

As Published: <http://dx.doi.org/10.1109/tbme.2009.2038487>

Publisher: Institute of Electrical and Electronics Engineers

Persistent URL: <http://hdl.handle.net/1721.1/62149>

Version: Final published version: final published article, as it appeared in a journal, conference proceedings, or other formally published context

Terms of Use: Article is made available in accordance with the publisher's policy and may be subject to US copyright law. Please refer to the publisher's site for terms of use.



A Wearable Sensor for Unobtrusive, Long-Term Assessment of Electrodermal Activity

Ming-Zher Poh, *Student Member, IEEE*, Nicholas C. Swenson, and Rosalind W. Picard*, *Fellow, IEEE*

Abstract—Electrodermal activity (EDA) is a sensitive index of sympathetic nervous system activity. Due to the lack of sensors that can be worn comfortably during normal daily activity and over extensive periods of time, research in this area is limited to laboratory settings or artificial clinical environments. We developed a novel, unobtrusive, nonstigmatizing, wrist-worn integrated sensor, and present, for the very first time, a demonstration of long-term, continuous assessment of EDA outside of a laboratory setting. We evaluated the performance of our device against a Food and Drug Administration (FDA) approved system for the measurement of EDA during physical, cognitive, as well as emotional stressors at both palmar and distal forearm sites, and found high correlations across all the tests. We also evaluated the choice of electrode material by comparing conductive fabric with Ag/AgCl electrodes and discuss the limitations found. An important result presented in this paper is evidence that the distal forearm is a viable alternative to the traditional palmar sites for EDA measurements. Our device offers the unprecedented ability to perform comfortable, long-term, and *in situ* assessment of EDA. This paper opens up opportunities for future investigations that were previously not feasible, and could have far-reaching implications for diagnosis and understanding of psychological or neurological conditions.

Index Terms—Electrodermal activity (EDA), forearm, galvanic skin response, skin conductance, sweat, sympathetic nervous system, wearable sensors, wrist.

I. INTRODUCTION

IN GENERAL, regulation of physiological states of arousal is achieved by a balance of activity within sympathetic and parasympathetic subdivisions of the autonomic nervous system (ANS). While the parasympathetic nervous system promotes restoration and conservation of bodily energy, the sympathetic nervous system stimulates increased metabolic output to deal with external challenges. As such, increased sympathetic activity (sympathetic arousal) elevates heart rate, blood pressure, and sweating, as well as redirects blood from the intestinal reservoir toward skeletal muscles, lungs, heart, and brain in preparation for motor action. Sympathetic postganglionic fibers consisting

of nonmyelinated class C nerve fibers surround eccrine sweat glands and their activity modulates sweat secretion [1]. Since sweat is a weak electrolyte and good conductor, the filling of sweat ducts results in many low-resistance parallel pathways, thereby increasing the conductance of an applied current. Changes in skin conductance at the surface, referred to as electrodermal activity (EDA), reflect activity within the sympathetic axis of the ANS and provide a sensitive and convenient measure of assessing alterations in sympathetic arousal associated with emotion, cognition, and attention [2]. Stress is generally defined as a disruption of the autonomic balance involving a state of high sympathetic activation. Since EDA is solely determined by the activity of the sympathetic branch of the ANS, which is predominant in stress states, tonic EDA parameters may be regarded as suitable measures of ANS activity induced by stress [3]. The hypothalamus, which is responsible for ANS activity, plays a major role in eliciting ipsilateral EDA under the direct influence of limbic structures [3]. These influences appear to stem from antagonistic actions of the amygdala (excitatory) and hippocampus (inhibitory) [4], [5]. Autonomic responses in the skin such as sweating, piloerection, and vasomotor changes can thus be elicited by various emotional states via the Papez circuit in the limbic system [6]. In addition, it is widely recognized that attention-grabbing stimuli and attention-demanding tasks also evoke increased EDA responses [7], [8].

Despite improvements in measuring equipment since the discovery of electrodermal phenomena more than 100 years ago [9]–[11], much of the research in this area is limited to observational measurements performed over short periods of time in laboratory settings or artificial clinical environments. The need for monitoring patients over extensive periods of time has stimulated interest in wearable technologies—unobtrusive devices that can be worn during normal daily activity to gather physiological data over periods of several weeks or months [12]. Long-term monitoring of EDA will allow the observation of patterns of sympathetic arousal and regulation at a significantly longer time scale (days to months) compared to existing studies (minutes to hours) and could potentially reveal previously unobservable trends. In addition, long-term measurements taken in a person's natural home environment also provide a clearer picture of the person's physiological state than a short period of assessment in an unnatural clinical setting [13]. Clinically, wearable EDA sensors can be used in psychopathology, dermatology, and neurology for diagnostic purposes and therapy evaluation. Potential clinical applications include screening for cystic fibrosis [14], classification of depressive illnesses [15], prediction of functional outcome in schizophrenia [16], discrimination between healthy and psychotic patients [17], characterization of

Manuscript received July 12, 2009; revised October 18, 2009. First published February 17, 2010; current version published April 21, 2010. This work was supported by the Nancy Lurie Marks Family Foundation. *Asterisk indicates corresponding author.*

M.-Z. Poh is with the Harvard-MIT Division of Health Sciences and Technology (HST), Cambridge, MA 02139 USA, and also with the Media Laboratory, Massachusetts Institute of Technology, Cambridge, MA 02139 USA (e-mail: zher@mit.edu).

N. C. Swenson is with the Media Laboratory, Massachusetts Institute of Technology, Cambridge, MA 02139 USA (e-mail: nswenson@mit.edu).

*R. W. Picard is with the Media Laboratory, Massachusetts Institute of Technology, Cambridge, MA 02139 USA (e-mail: picard@media.mit.edu).

Color versions of one or more of the figures in this paper are available online at <http://ieeexplore.ieee.org>.

Digital Object Identifier 10.1109/TBME.2009.2038487

sympathetic arousal in autism [18], early diagnosis of diabetic neuropathy [19] and providing biofeedback in treating chronic hyperhidrosis [20], epileptic [21], and psychogenic nonepileptic [22] seizures.

At present, ambulatory EDA devices are often composed of a processing unit/A–D converter and external probes that reduce comfort levels. Commercial sensor systems such as Flex-Comp [23], SenseWear [24], QPET [25], and Vitaport [26] offer high-quality EDA recordings, but their current bulky form factors and high prices limit their widespread use for long-term ambulatory studies. Similarly, Tronstad *et al.* [27] proposed a portable logger for EDA long-term measurements, but its size is still considerably too large (157 mm × 95 mm × 33 mm) to be practical for continuous monitoring or to be considered a wearable device. The HandWave Bluetooth skin conductance sensor represents a significant improvement in terms of size [28]. However, like many other similar devices [29], [30], the placement of electrodes on the fingers or palms requires external connections, and is encumbering and highly susceptible to motion or pressure artifacts [31]. A recent proposal to measure EDA unobtrusively through imaging means [32] offers much promise, but the measurements carry substantial noise and quantification remains difficult.

To achieve widespread, continuous, and long-term assessment of EDA, there is a need for a sensor that not only is low cost, compact, and unobtrusive, but also comfortable to wear and nonstigmatizing to the user. In this paper, we present a novel solution in the form of a wearable and fully integrated EDA sensor that fulfills these characteristics. The study focuses on comparing the performance of the proposed system with a Food and Drug Administration (FDA) approved EDA measurement system during classic arousal experiments involving physical, cognitive, and emotional stressors. We first validate the performance of the proposed sensor during EDA measurements from traditional palmar recording sites. In addition, we study the use of the ventral side of the distal forearms as a recording site for EDA measurements that is nonencumbering. We also investigate how the choice of electrode material affects performance by comparing the use of conductive fabric electrodes to standard Ag/AgCl electrodes. Finally, we present a week-long recording of EDA during daily activity. To the best of our knowledge, it is the first demonstration of long-term, continuous EDA assessment outside of a laboratory setting.

II. SYSTEM DESIGN

A. Sensor Module

The overall system is illustrated in Fig. 1. Direct-current (dc) is applied to the stratum corneum beneath measuring electrodes for exosomatic measurements of EDA. To achieve a wide dynamic range of skin conductance measurements, the analog conditioning circuitry utilizes nonlinear feedback automatic bias control with low-power operational amplifiers (LTC6081 by Linear Technology). A triple-axis accelerometer (ADXL330 by Analog Devices, Inc.) is also included for physical activity measurements. Accelerometry is a low-cost, flexible, and accurate method for the analysis of posture and movement.

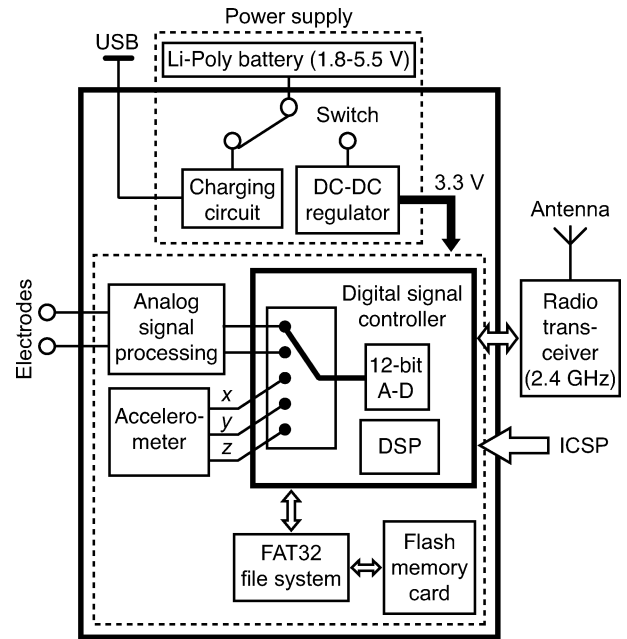

Fig. 1. Overview of the EDA sensor system architecture. The device is capable of recording measurements onto an onboard flash memory card (data logging), wirelessly transmitting data to a remote site (data forwarding), and performing real-time analysis (data processing).

A digital signal controller (DSC) (dsPIC30F2012 by Microchip Technology, Inc.) acts as the control center that can be programmed onboard through an in-circuit serial programming (ICSP) interface. DSCs combine the control attributes of a microcontroller (MCU) and computation capabilities of a digital signal processor (DSP), thus allowing application-specific real-time complex analysis onboard. The analog signals are sampled at 32 Hz via an A–D with 12-bit resolution on the DSC. Power is drawn from a single lithium polymer battery with a nominal voltage of 3.7 V and a capacity of 1100 mAh. The battery can be recharged directly from a universal serial bus (USB) port by an onboard single-cell Li-ion battery charger (LTC4062 by Linear Technology). A step-up/step-down charge pump (LTC3240 by Linear Technology) produces a fixed, regulated output of 3.3 V for the DSC and peripheral components.

In order to enable continuous measurements of EDA and physical activity without the constraint of staying within range of a base station, a data logging system is available onboard. Using a separate MCU with dedicated firmware to implement a FAT32 file system (uALFAT by GHI Electronics, LLC) that communicates with the DSC through a universal asynchronous receiver/transmitter (UART) interface, data can be written to removable flash memory card. A 2G microSD card provides enough storage capacity for up to 28 days of continuous measurements with a sampling rate of 32 Hz. If it is desirable for the data to be accessible to the wearer's caregiver for analysis and interpretation, or if the wearer chooses to share his/her recordings, the proposed system can also operate as a data-forwarding device with the use of a 2.4-GHz transceiver module (nRF2401 A by Sparkfun Electronics). In this mode, real-time measurements can be displayed on a PC equipped with a separate transceiver

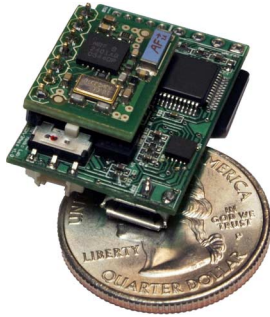

Fig. 2. EDA sensor module. The device has a modular design and is shown with an optional radio transceiver mounted on top.



Fig. 3. Wearable EDA sensor. (a) Final packaging in an attractive and inconspicuous wristband. (b) Disposable Ag/AgCl electrodes attached to the underside of the wristband. (c) Wearable EDA sensor can be worn comfortably on the wrist for long periods of time and during daily activities.

module for immediate analysis. The complete electronic module (20 mm × 30 mm × 0.8 mm) is shown in Fig. 2.

B. Packaging

User comfort is a major consideration in the design of any wearable device intended for long-term and continuous use. Regardless of the capabilities of a wearable system, users will not be inclined to wear them on a daily basis over a period of days or weeks if the sensors are bulky and cumbersome. In view of this, we integrated the electronic module into a regular wristband made out of terrycloth, resulting in a comfortable, attractive, and lightweight wearable sensor (see Fig. 3). Since all electronics and wiring are concealed within the wristband, the resulting

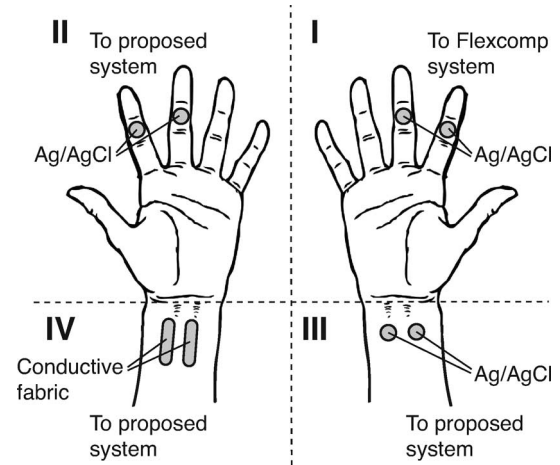

Fig. 4. Experimental setup. Measurements were recorded from (I) right fingers with the Flexcomp system, (II) left fingers with the proposed sensor module, (III) right distal forearm with the proposed sensor module using Ag/AgCl electrodes, and (IV) left distal forearm with the proposed sensor module using conductive fabric electrodes.

device is also inconspicuous, nonstigmatizing, and allows for discrete monitoring of EDA. Furthermore, the electronic module can be easily detached when the user desires to wash the wristband.

To date, there is no generally accepted standardization with respect to electrodermal recording sites [3]. The electrodes are commonly placed on the palmar surface of the hand, the most popular sites being the medial and distal phalanges of the fingers, and the thenar and hypothenar eminences (see Fig. 4). However, since both hands are often needed for manipulation, placement of electrodes on these sites is highly susceptible to motion artifacts and interferes with daily activities. Thus, we decided to use the ventral side of the distal forearms as our recording sites. We chose to use Ag/AgCl disc electrodes with contact areas of 1.0 cm² (Thought Technology, Ltd.) for our recordings, as recommended in the literature [33]. These electrodes are disposable and can be snapped onto or removed from the wristband with ease [see Fig. 3(b)].

Overall, the complete wearable EDA sensor is compact (70 mm × 70 mm × 20 mm), lightweight (40.3 g), and the components used can be purchased off the shelf for approximately \$150. In contrast, a commercial system such as the Flexcomp Infiniti (Thought Technologies, Ltd.) measures 130 mm × 95 mm × 37 mm, weighs 200 g, and costs \$6000 for the data acquisition unit, and an additional \$275 for an EDA sensor.

III. EXPERIMENTAL METHODS

A. Participants

Data were collected from 26 participants between the ages of 18–56 during three separate experiments (physical task, cognitive task, and emotional task) each consisting of a baseline, task, and recovery period. Some participants underwent two consecutive experiments (order of experiments was not fixed), so there was overlap between the recovery period of the first experiment and baseline of the second experiment. This study

(0801002576) was approved by the Massachusetts Institute of Technology Committee On the Use of Humans as Experimental Subjects (COUHES). Informed consent was obtained from all participants prior to the beginning of the research session. Sixteen participants (eight females and eight males) were enrolled in a physical task, 15 participants (nine females and six males) underwent a cognitive task, and 13 participants (eight females and five males) were subjected to an emotional task. Due to battery failure on the Flexcomp (one person) and motion-corrupted data (one person), full-length recordings were not available for two participants during the cognitive task, but uncorrupted sections were included in analysis. We excluded data from three participants in the physical task due to failure to turn the proposed sensor on (one person), disconnection of finger electrodes from the Flexcomp during task (one person), and motion-corrupted finger data (one person).

In addition, one participant volunteered to wear the proposed sensor for a long-term experiment to measure EDA *in situ*.

B. Physiological Measurements

EDA was measured as skin conductance changes using either the proposed system or a “gold standard,” commercially available and FDA-approved device (Flexcomp Infinity, Thought Technologies, Ltd.) at four different recording sites (see Fig. 4). Ag/AgCl electrodes embedded in hook-and-loop fastener bands were secured around the medial phalanges of the index and middle fingers bilaterally. The electrodes on the right fingers were connected to the Flexcomp Infinity (which served as our control), while the electrodes on the left fingers were connected to the proposed sensor module for EDA measurements. A wearable EDA sensor (wristband) was placed on each distal forearm with the sensor module on the right connected to Ag/AgCl electrodes, and the sensor module on the left connected to stretch conductive fabric (silver plated 92%, nylon 8%, surface resistance $<1 \Omega/\text{sq}$, and contact area of 3.5 cm^2) that was sewn into the wristband in the place of the Ag/AgCl electrodes. Electrodes for both wristbands were in contact with the ventral side of the distal forearms. There was no pretreatment of recording sites and no conductive gel was applied to the electrodes. The clocks for the proposed sensors and the Flexcomp were synchronized prior to the start of each experiment, and the time was recorded at the beginning and end of each condition. The sampling frequency for all signals was fixed at 32 Hz.

C. Physical Task

During the baseline period, participants were asked to sit quietly on the seat of a recumbent bicycle (Precor USA, Inc.) and relax for 10 min. Participants were then asked to pedal as fast as they could for a duration of 5 min at a fixed resistance of level 7. After the cycling task, participants were asked to remain seated for a recovery period of 10 min.

D. Cognitive Task

Participants were seated in a darkened and sound-dampened room facing a large screen and briefly oriented to their surround-

ings. At the start of the experiment, participants sat quietly for 10 min to obtain a baseline recording. Participants were then asked to follow instructions on the screen for a cognitive task. On-screen instructions requested them to perform serial subtractions in intervals of seven, starting with a four-digit number, and to deliver their responses vocally for a 3-min period. A countdown timer was visible to the participants and a buzzer was sounded for each mistake in subtraction. The mental arithmetic task was followed by a Stroop word-color matching test. A slide consisting of color words (red, blue, green, brown, and purple), each printed in a color differing from the color it named was displayed on the screen and participants were asked to read the names of the colors serially as quickly as possible in 1 min. Once again, a countdown timer was visible and participants were alerted to errors by a buzzer. At the end of 1 min, the task was repeated again with a second slide that had the words printed in the reverse order. After completion of the task, participants were asked to remain seated and relax for a recovery period that lasted for 10 min.

E. Emotional Task

Similar to previous task, participants were seated in a darkened and sound-dampened room facing a large screen and briefly oriented to their surroundings. At the start of the experiment, participants sat quietly for 10 min to obtain a baseline recording. After establishing a baseline, participants were informed by an investigator that a horror movie would be played and waited in anticipation for 1 min. A 5-min clip from the movie “28 Days Later” involving scenes of chaos, violence, and disturbing images was then shown. At the end of the movie clip, participants were asked to remain seated and relax for a recovery period that lasted for 10 min.

F. Long-Term In Situ Experiment

A healthy volunteer (19-year-old male) was instructed to wear the proposed sensor with Ag/AgCl electrodes on his left distal forearm 24/7 for a week to measure long-term EDA during daily activities. He was given the option to stop participating in the experiment at any moment and to remove the wristband at any time he chose. After a period between 24 and 30 h, the volunteer removed the micro-SD card to download the data and also replaced the battery. This was repeated daily for a total of seven days.

G. Data Analysis

All data files were analyzed using custom software written in MATLAB (The MathWorks, Inc.). The raw EDA signals were filtered with a 1024-point low-pass filter (Hamming window, cutoff frequency of 3 Hz) to reduce motion artifacts and electrical noise. Pearson’s correlation coefficients and the corresponding *p*-values were calculated for the filtered recordings from the different sites and systems as a measure of similarity between signals.

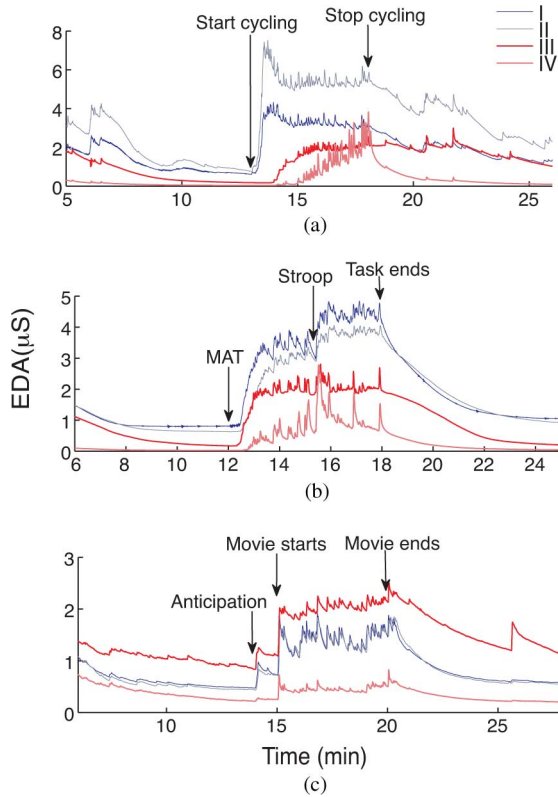
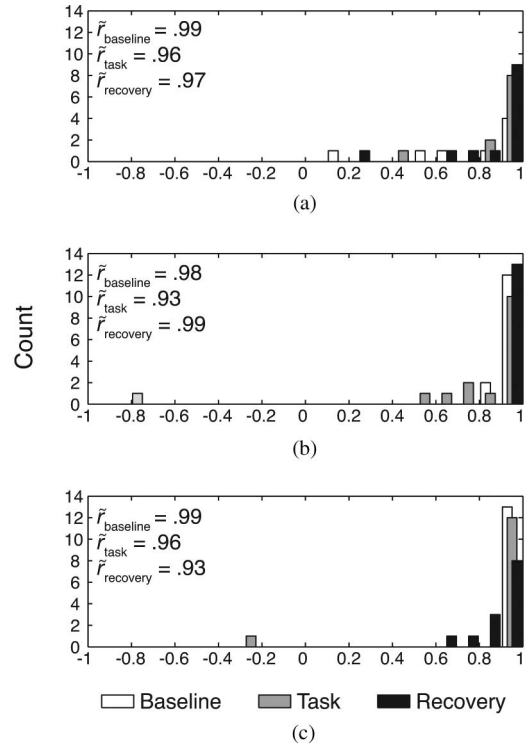

Fig. 5. EDA waveforms during (a) physical activity, (b) cognitive stressors, and (c) emotional stressors (a horror movie clip). Measurements were recorded from (I) right fingers with the Flexcomp system, (II) left fingers with the proposed sensor module, (III) right distal forearm with the proposed sensor module using Ag/AgCl electrodes, and (IV) left distal forearm with the proposed sensor module using conductive fabric electrodes. (a) Physical stressors (subject 6). (b) Cognitive stressors (subject 14). (c) Emotional stressors (subject 9).

IV. RESULTS

A. EDA Increases During Stressor Tasks

All participants reported that the wearable EDA sensors (wristbands) felt comfortable throughout the duration of the study. Examples of typical EDA signals measured during the three different experiments are presented in Fig. 5. In all three experiments, skin conductance gradually decreased to a plateau during the initial relaxation period to establish a baseline. During the physical task, skin conductance increased as the participant was cycling [see Fig. 5(a)]. In the course of the cognitive task experiment [see Fig. 5(b)], the start of the mental arithmetic test (MAT) was followed by a step rise in skin conductance level (SCL) that remained elevated throughout the test. Skin conductance increased to a higher level during the Stroop word-color matching task in 73.3% of participants. Multiple skin conductance responses (SCRs) were also evident during the tasks. From Fig. 5(c), we see that an SCR was generated when the investigator informed the participant that a horror movie would be played. At the start of the movie, the SCL surged upward and remained high with multiple SCRs throughout the movie. When the tasks ended and the participant was asked to relax, skin conductance decreased steadily to near baseline in all three experiments.



Correlation coefficient, r ($p < 0.0001$ for all observations)

Fig. 6. Distributions of correlation coefficients between EDA measurements from bilateral fingers [Fig. 4(I and II)] under (a) physical ($n = 13$), (b) cognitive ($n = 15$), and (c) emotional ($n = 13$) stressors. Each experiment was separated into baseline, task, and recovery conditions for correlation. The median values of the correlation coefficients \tilde{r} are also presented for each condition. (a) Physical stressors. (b) Cognitive stressors. (c) Emotional stressors.

From Fig. 5, we also see that recordings from our sensor modules on the fingers (II) and distal forearm with Ag/AgCl electrodes (III) are in very close agreement with recordings from the Flexcomp on the fingers (I). Overall, recordings on the wrist with conductive fabric electrodes (IV) produced the lowest skin conductance measurements in 86.7% of participants during the cognitive task and 84.6% of participants during the emotional task. However, the fabric electrodes produced highest readings toward the end of the physical task and during the subsequent recovery period in 46.2% of participants.

B. Recordings of Proposed System are Highly Accurate and Strongly Correlated With FDA System

To evaluate the performance characteristics of our sensor module, we correlated the measured EDA signals by the proposed device with the Flexcomp from the left and right fingers, respectively, (I and II in Fig. 4) during the baseline, task, and recovery conditions for all three experiments. The resulting histograms of the correlation coefficients r are displayed in Fig. 6 ($p < 0.0001$ for all observations). Since some of the distributions were slightly negatively skewed and the mean is not robust to outlying observations, we chose to use the median \tilde{r} as the measure of central tendency. Overall, recordings from the proposed system and the Flexcomp were strongly correlated ($0.93 \leq \tilde{r} \leq$

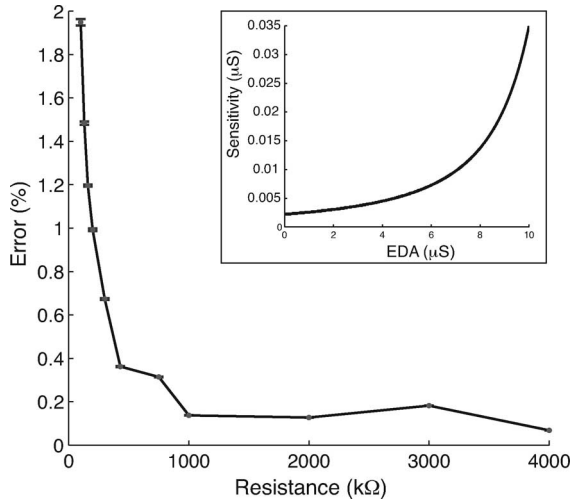

Fig. 7. Accuracy of the proposed sensor in fixed-resistance measurements. Error bars represent 1 S.D. Inset: Computed sensitivity of the proposed sensor showing increasing quantization error at higher EDA values.

0.99) during the baseline, task, and recovery period for all three experiments.

To test the accuracy of the proposed system, we measured a series of 1% fixed resistors representative of typical skin resistance values (0.1–4.0 M Ω) with the proposed device and compared our readings to that of a digital multimeter (0.5% accuracy). The resulting error plot and computed sensitivity of the proposed system is presented in Fig. 7. The measurement error of our device was higher at lower resistance values, which is likely due to the increasing quantization error at higher conductance values (see Fig. 7 inset). Within the tested range of resistances, the mean measurement error was found to be small ($0.68 \pm 0.64\%$). Across a range of typical skin conductance values, the mean sensitivity of the proposed device ($0.01 \pm 0.01 \mu\text{S}$) was comparable to that of the Flexcomp ($0.01 \mu\text{S}$).

C. Distal Forearm is a Viable EDA Recording Site

To examine the degree to which distal forearm EDA activity parallels finger EDA activity (a traditional recording site), we correlated the EDA signals from the distal forearms with EDA signals from ipsilateral fingers (I and III, and II and IV in Fig. 4). Fig. 8 presents the histograms of resulting correlation coefficients for the two different electrode types for all three experiments ($p < 0.0001$ for all observations). In general, the distributions were negatively skewed with long tails to the left. Based on the median of the correlation coefficients \tilde{r} , correlation between the fingers and distal forearm was very strong ($0.76 \leq \tilde{r} \leq 0.96$) during the baseline and recovery periods for all but the physical and emotional recovery period with the Ag/AgCl electrodes. There was also a strong correlation between the fingers and distal forearm during the physical ($\tilde{r} = 0.78$) and emotional ($\tilde{r} = 0.72$) tasks. During the cognitive task, the correlations were lower, but remained moderately strong ($\tilde{r} = 0.57$).

By using Ag/AgCl electrodes on the right distal forearm and conductive fabric electrodes on the left distal forearm, we also compared the performance of the different electrode materials.

Although the correlation between fingers and distal forearm was also very strong ($0.74 \leq \tilde{r} \leq 0.88$) during baseline and recovery periods with the conductive fabric electrodes, the correlation was weak during physical ($\tilde{r} = 0.35$) and cognitive tasks ($\tilde{r} = 0.45$), and moderately strong during the emotional task ($\tilde{r} = 0.57$). In addition, we herein define a performance index π to be the proportion of observations with moderately strong ($0.5 \leq r < 0.8$) to very strong ($r \geq 0.8$) correlation coefficients. Ag/AgCl electrodes yielded high performance for all three tasks ($0.69 \leq \pi \leq 0.77$), but for conductive fabric electrodes, the performance index was lower ($0.46 \leq \pi \leq 0.54$). From this perspective, the Ag/AgCl electrodes once again performed better than conductive fabric electrodes, particularly during the stressor task periods. Evidence from the analysis of correlation of EDA between fingers and distal forearms suggest that there are large interindividual differences with a small proportion (19%) of negative correlations.

D. Long-Term In Situ EDA Recordings Reveal Patterns in Autonomic Arousal

The participant who wore the proposed sensor for a week reported no side effects or discomfort. From Fig. 9, we see that long-term *in situ* recordings contain rich information about daily patterns of skin conductance modulation. For example, there is a consistent peak between the hours of midnight and 3 am, corresponding to sleep activity. No SCL drift was observable and the recordings were relatively artifact free, demonstrating the ability of the proposed sensor to continuously measure EDA during daily activities. The biggest advantage of the proposed wrist-worn Ag/AgCl sensor is the unprecedented ability to perform comfortable and long-term EDA measurements *in situ*, capturing differences in activities such as sleep, studying, laboratory work, class work, etc., without having to recalibrate baselines and worry about whether levels are comparable.

V. DISCUSSION

As an index of sympathetic nervous system activity, EDA offers important insight into a broad spectrum of psychological and neurological disorders. The proposed sensor wristband provides a practical and comfortable new solution for widespread EDA assessment. Using Ag/AgCl electrodes, we found strong correlation between the proposed sensor wristband and an FDA-approved EDA measurement system across all tests. This capability for long-term EDA measurements both within and outside of a laboratory or clinical setting creates exciting opportunities for investigations that would otherwise have been difficult to implement.

It is not a trivial task to design experiments for performance comparison between different EDA sensors. Measurements of fixed resistors alone are insufficient and do not provide evaluation of the dynamic properties of the EDA sensors. Therefore, there is a need to perform tasks that are well known to elicit changes in EDA while performing simultaneous measurements with the proposed system and an established system. However, both pairs of electrodes cannot be placed on the same recording site due to crosstalk interference. Due to the effect of

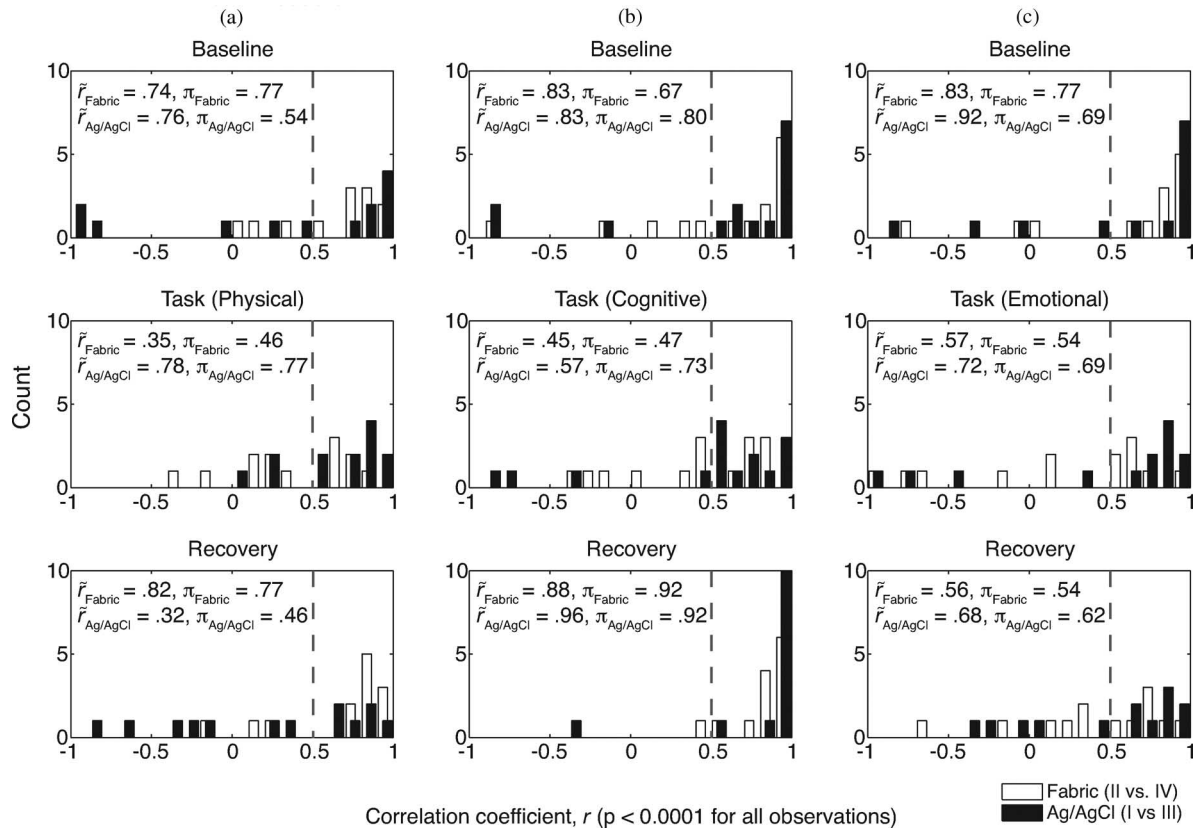

Fig. 8. Distributions of correlation coefficients between EDA measurements from distal forearms (conductive fabric electrodes on the left distal forearm and Ag/AgCl electrodes on the right distal forearm) and ipsilateral fingers under (a) physical ($n = 13$), (b) cognitive ($n = 15$), and (c) emotional ($n = 13$) stressors. Each experiment was separated into a baseline, task, and recovery conditions for correlation. The median values of the correlation coefficients \bar{r} along with the performance indexes (proportion of correlation coefficients ≥ 0.5) π are also presented for each condition. Dashed lines indicate $r = 0.5$. (a) Physical stressors. (b) Cognitive stressors. (c) Emotional stressors.

habituation, which is characterized by decreasing reaction intensity with repeated stimulation, performing repeated measurements with the different sensors is also not a practical solution. This problem can be avoided by placing the different pairs of electrodes on bilateral recording sites, but there still exists issues concerning left-hand/right-hand differences in EDA [34], [35]. Thus, it is important to point out the fact that even with identical sensors (e.g., Flexcomp) placed on bilateral sites, one should not expect to obtain identical measurements. With this caveat, we formulated the experimental setup described in Section III-B and depicted in Fig. 4 with the goal of comparing the performance characteristics of the proposed EDA sensor with a “gold standard,” FDA-approved and commercially available EDA measurement system (Flexcomp).

The three experiments performed were selected to capture a variety of EDA responses to classic stimuli. Furthermore, the cognitive experiment consisted of two separate tasks of differing complexity (mental arithmetic task and the Stroop word-color matching test), while the emotional experiment also elicited an anticipatory response prior to providing emotional stimuli. It is well known that stress can induce an increase in both tonic and phasic components of EDA. Our measured EDA recordings showed changes of skin conductance from baseline (at rest) in response to a stressor task and during recovery. As expected, skin conductance increased during physical strain, induced by

intense exercise, and emotional strain, induced by mental arithmetic, the Stroop word-color matching task, and the horror movie clip. Although it is tempting to assume that each different EDA waveform represents either purely thermoregulatory or emotional sweating, it is worth noting that the responses are likely a combination of different sweating mechanisms. For example, sweating from physical exercise involves both thermal and mental sweating [36], and the rapid change from baseline at the start of the various stressor tasks presumably involves the orienting response. Therefore, these recordings merely demonstrate changes in EDA under different stressors. Emotional sweating (increased sweat gland activity as a concomitant of psychological, and especially, emotional states) has been observed mainly on palmar and plantar sites, but the specificity of emotional sweating remains in question [37]. Our findings indicate that the ventral sides of the distal forearms can also produce sweat responses to emotional stimuli. The strong correlations between the proposed device and the Flexcomp indicate that our system functions as intended.

The wide distribution in correlation coefficients between the fingers and the dorsal forearm could be due to differences in sweat gland distribution or skin sudomotor innervation. Indeed, the two most commonly used dermatome maps present different spinal nerve innervations at the ventral side of the distal forearms. According to Fender [38], dermatomes of the ventral

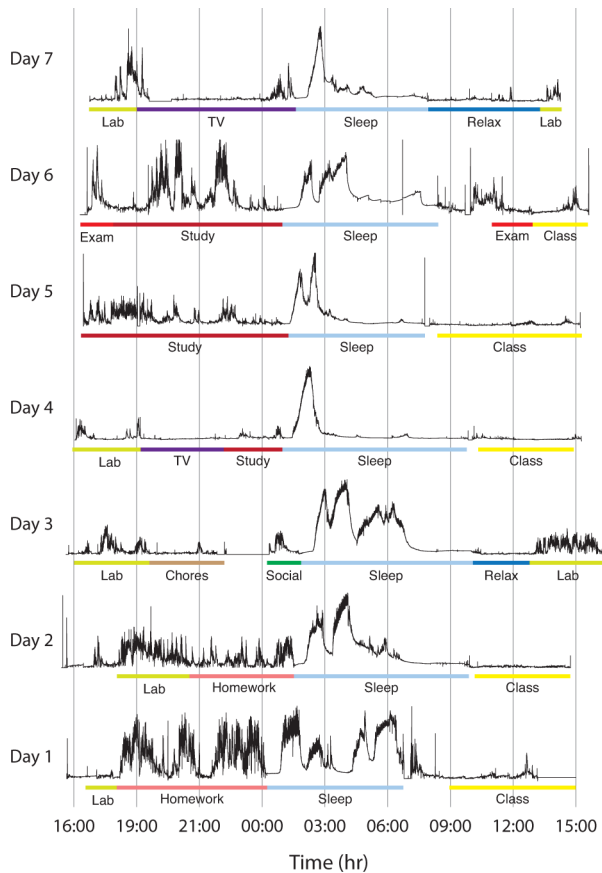

Fig. 9. Long-term *in situ* EDA recordings. Continuous skin conductance measurements were recorded for seven days in a natural home environment. Daily EDA waveforms displayed are normalized.

side of the distal forearms are continuous with the palmar sites (C6–C8), but Keegan and Garrett [39] describe the ventral side of the distal forearms as innervated by dermatomes C5, C6, C8, and T1. In addition, differences in moisture buildup between the skin–electrode interfaces could also contribute to the large variance of correlation coefficients. This was particularly evident at the end of the physical task, which resulted in negative-correlation coefficients in 38% of participants (decreasing skin conductance at fingers, but increasing skin conductance at distal forearms). There is a lack of evidence to suggest a dependence on age or gender. Nonetheless, the overall pattern of results suggests that the EDA measured from the distal forearms closely parallels EDA measured from the fingers.

Using conductive fabric as electrodes is an attractive option in designing wearable sensors as it potentially enables greater comfort. Although at rest and recovery, the conductive fabric electrodes performed somewhat similarly to conventional Ag/AgCl electrodes, it is important to take note that they have weaker ability to measure EDA changes during stressor tasks. Given the stretchy nature of the conductive fabric, it is likely that the electrodes do not maintain their electrical properties when in contact with the user. Furthermore, the ability of fabric to absorb moisture and sweat also contributes to altering their electrical properties over time and is the likely reason for our results showing that the levels of EDA were higher after the

physical exertion task for the conductive fabric electrodes than for the traditional Ag/AgCl electrodes. In view of this, we recommend using standard Ag/AgCl electrodes for more sensitive analysis of EDA measurements.

Long-term assessment of EDA revealed interesting trends in the participant's sympathetic modulation over a week-long period. Intervals of elevated EDA frequently corresponded to times when the participant was studying, doing homework, or taking an exam. This is possibly due to the increased cognitive stress associated with these activities. The characteristic peaks occurring during sleep have been associated with slow-wave sleep [40] and remain a subject for future studies. We found the sensor wristband to provide reliable and robust attachment of the electrodes to the skin, even in the presence of forearm motion during normal daily activities. Motion artifacts were typically observed only when the electrode–skin interface was disturbed such as when external pressure was applied against the electrodes or when the wearer readjusted the position of the electrodes.

VI. CONCLUSION

We have presented a compact and low-cost wearable EDA sensor that enables comfortable long-term assessment of EDA. The novelty of our system consists of the use of the dorsal forearms as recording sites, the miniaturization of the sensor module, as well as the design of a small wristband that allows for unobtrusive and nonstigmatizing continuous EDA measurements during everyday activities. Experimental outcomes using Ag/AgCl electrodes correlated strongly with the FDA-approved EDA measurement system. To the best of our knowledge, we described the first detailed study indicating that the ventral side of the distal forearms is a viable alternative to the more popular palmar sites for EDA measurements across physical, cognitive, and emotional stressors. Importantly, we also presented the first long-term recordings of EDA during daily activity outside of a laboratory or clinical setting. While palmar electrodes are encumbering, easily lost, and frequently subjected to motion and pressure artifacts, the proposed wrist-worn sensor does not suffer anywhere near as much from these problems. Given the versatility of the proposed system that acts both as a data forwarding and data logging device, users are not constrained to stay within the range of a base station, but, instead, have unrestricted continuous measurements regardless of location. The importance of this paper is the unprecedented ability to perform comfortable long-term and *in situ* assessment of EDA that the proposed system offers. Long-term continuous EDA measurements during normal daily activity like that in Fig. 9 have, to the best of our knowledge, not prior to this paper been demonstrated in a practical way, and thus, the new technology developed in this paper represents a significant advancement over existing systems. Investigations of long-term sympathetic nervous system activity can potentially add precious insight and enrich understanding of widespread neurological conditions. Studies are currently underway to evaluate the use of the proposed EDA sensor in a variety of clinical applications, including autism, epilepsy, and sleep disorders.

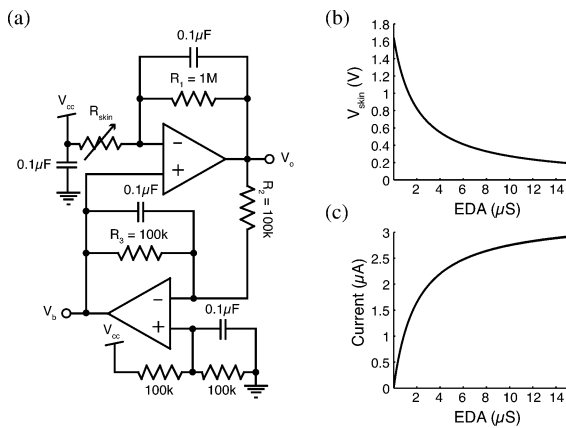

Fig. 10. (a) Circuit for EDA measurements. Computed profiles for the (b) voltage and (c) current flow across skin for a range of typical skin conductance values.

APPENDIX

For exosomatic measurements of EDA by dc, the constant current or constant voltage method is commonly used. However, these traditional methods face difficulty in amplifying the EDA signal since inter- and intraindividual variations in tonic SCLs result in a large dynamic range [3]. On the other hand, the phasic SCRs are relatively small. In order to achieve a sufficiently high resolution of the SCRs over a dynamic range of SCLs without having to uncouple the two components, we employed an automatic bias control method using two operation amplifiers [see Fig. 10(a)]. The first stage comprises an active low-pass filter (cutoff frequency $f_c = 1.6$ Hz) with variable gain. To increase the dynamic range of measurements, the bias V_b of the first operational amplifier is determined by the feedback from the output of the second stage integrator V_o (time constant $\tau = 10$ ms). The applied voltage across the skin decreases in a nonlinear fashion with increasing skin conductance [see Fig. 10(b)]. Although the current flow through the skin increases nonlinearly with skin conductance [see Fig. 10(c)], the current density is well below the recommended limit of $10 \mu\text{A}/\text{cm}^2$ [41]; thus, there is minimal risk of damaging sweat glands. Within a range of skin conductance between 0.1 and $15 \mu\text{S}$, the average voltage applied is 0.47 V and the average current flow is $2.37 \mu\text{A}$. Overall, the skin resistance R_{skin} can be calculated as follows:

$$R_{\text{skin}} = \left(\frac{V_{cc} - V_b}{V_b - V_o} \right) R_1. \quad (1)$$

EDA measured as skin conductance can be obtained simply by taking the inverse of (1).

ACKNOWLEDGMENT

The authors would like to thank M. Feldmeier, K. Dobson, M. S. Goodwin, R. Fletcher, O. Wilder-Smith, Y. Kuboyama, E. Hedman, and S. Goyal for their valuable feedback, K. H. Kim for actively recruiting participants for this study, and Thought Technologies for generously donating the Flexcomp Infinity System.

REFERENCES

- [1] K. Sato, W. H. Kang, K. Saga, and K. T. Sato, "Biology of sweat glands and their disorders. I. Normal sweat gland function," *J. Amer. Acad. Dermatol.*, vol. 20, pp. 537–563, Apr. 1989.
- [2] H. D. Critchley, "Electrodermal responses: what happens in the brain," *Neuroscientist*, vol. 8, pp. 132–142, Apr. 2002.
- [3] W. Boucsein, *Electrodermal Activity*. New York: Plenum, 1992.
- [4] T. Yokota, A. Sato, and B. Fujimori, "Inhibition of sympathetic activity by stimulation of limbic system," *Jpn. J. Physiol.*, vol. 13, pp. 138–144, Apr. 15, 1963.
- [5] T. Yokota and B. Fujimori, "Effects of brain-stem stimulation upon hippocampal electrical activity, somatomotor reflexes and autonomic functions," *Electroencephalogr. Clin. Neurophysiol.*, vol. 16, pp. 375–382, Apr. 1964.
- [6] J. W. Papez, "A proposed mechanism of emotion," *J. Neuropsychiatry Clin. Neurosci.*, vol. 7, pp. 103–112, 1937.
- [7] R. Edelberg, "Electrodermal recovery rate, goal-orientation, and aversion," *Psychophysiology*, vol. 9, pp. 512–520, Sep. 1972.
- [8] S. M. Vaez Mousavi, R. J. Barry, J. A. Rushby, and A. R. Clarke, "Arousal and activation effects on physiological and behavioral responding during a continuous performance task," *Acta Neurobiol. Exp. (Wars)*, vol. 67, pp. 461–470, 2007.
- [9] R. Vigouroux, "Sur le rôle de la résistance électrique des tissus dans l'électro-diagnostic," *Comp. Rend. Soc. Biol.*, vol. 31, pp. 336–339, 1879.
- [10] Féré, "Note sur les modifications de la résistance électrique sous l'influence des excitations sensorielles et des émotions," *Comp. Rend. Soc. Biol.*, vol. 5, pp. 217–219, 1888.
- [11] J. Tarchanoff, "Décharges électriques dans la peau de l'homme sous l'influence de l'excitation des organes des sens et de différentes formes d'activité psychique," *Comp. Rend. Soc. Biol.*, vol. 41, pp. 447–451, 1889.
- [12] P. Bonato, "Wearable sensors/systems and their impact on biomedical engineering," *IEEE Eng. Med. Biol. Mag.*, vol. 22, no. 3, pp. 18–20, May/June 2003.
- [13] C. Ni Scanail, S. Carew, P. Barralon, N. Noury, D. Lyons, and G. M. Lyons, "A review of approaches to mobility telemonitoring of the elderly in their living environment," *Ann. Biomed. Eng.*, vol. 34, pp. 547–563, Apr. 2006.
- [14] P. S. Williamson, D. C. Fowles, and M. Weinberger, "Electrodermal potential and conductance measurements clinically discriminate between cystic fibrosis and control patients," *Pediatr. Res.*, vol. 19, pp. 810–814, Aug. 1985.
- [15] A. M. Mirkin and A. Coppen, "Electrodermal activity in depression: Clinical and biochemical correlates," *Brit. J. Psychiatry*, vol. 137, pp. 93–97, Jul. 1980.
- [16] A. M. Schell, M. E. Dawson, A. Rissling, J. Ventura, K. L. Subotnik, M. J. Gitlin, and K. H. Nuechterlein, "Electrodermal predictors of functional outcome and negative symptoms in schizophrenia," *Psychophysiology*, vol. 42, pp. 483–492, Jul. 2005.
- [17] M. P. Tarvainen, A. S. Koistinen, M. Valkonen-Korhonen, J. Partanen, and P. A. Karjalainen, "Analysis of galvanic skin responses with principal components and clustering techniques," *IEEE Trans. Biomed. Eng.*, vol. 48, no. 10, pp. 1071–1079, Oct. 2001.
- [18] W. Hirstein, P. Iversen, and V. S. Ramachandran, "Autonomic responses of autistic children to people and objects," *Proc. Biol. Sci.*, vol. 268, pp. 1883–1888, Sep. 22, 2001.
- [19] N. Dolu, C. Ozesmi, N. Comu, C. Suer, and A. Golgeli, "Effect of hyperglycemia on electrodermal activity in diabetic rats," *Int. J. Neurosci.*, vol. 116, pp. 715–729, Jun. 2006.
- [20] P. Duller and W. D. Gentry, "Use of biofeedback in treating chronic hyperhidrosis: A preliminary report," *Brit. J. Dermatol.*, vol. 103, pp. 143–146, Aug. 1980.
- [21] Y. Nagai, L. H. Goldstein, P. B. Fenwick, and M. R. Trimble, "Clinical efficacy of galvanic skin response biofeedback training in reducing seizures in adult epilepsy: A preliminary randomized controlled study," *Epilepsy Behav.*, vol. 5, pp. 216–223, Apr. 2004.
- [22] N. Pop-Jordanova, T. Zorcec, and A. Demerdzieva, "Electrodermal biofeedback in treating psychogenic nonepileptic seizures," *Prilozi*, vol. 26, pp. 43–51, Dec. 2005.
- [23] Flexcomp, "Flexcomp Infinity," New York, USA: Thought Technologies Ltd., 2009.
- [24] SenseWear, "SenseWear," Pittsburgh, PA: BodyMedia, Inc., 2009.
- [25] QPET, "QPET," Almelo, Netherlands: Brainquiry B.V., 2009.
- [26] Vitaport, "Vitaport," Kerkrade, Netherlands: TEMEC Instruments B.V., 2009.

- [27] C. Tronstad, G. E. Gjein, S. Grimnes, O. G. Martinsen, A. L. Krogstad, and E. Fosse, "Electrical measurement of sweat activity," *Physiol. Meas.*, vol. 29, pp. S407–S415, Jun. 2008.
- [28] M. Strauss, C. Reynolds, S. Hughes, K. Park, G. McDarby, and R. W. Picard, "The HandWave bluetooth skin conductance sensor," presented at the 1st Int. Conf. Affective Comput. Intell. Interact., Beijing, China, 2005.
- [29] Y. B. Lee, S. W. Yoon, C. K. Lee, and M. H. Lee, "Wearable EDA sensor gloves using conducting fabric and embedded system," in *Proc. Conf. Proc. IEEE Eng. Med. Biol. Soc.*, 2006, pp. 6785–6788.
- [30] F. Axisa, C. Gehin, G. Delhomme, C. Collet, O. Robin, and A. Dittmar, "Wrist ambulatory monitoring system and smart glove for real time emotional, sensorial and physiological analysis," in *Proc. 26th Annu. Int. Conf. IEEE Eng. Med. Biol. Soc.*, San Francisco, CA, 2004, pp. 2161–2164.
- [31] W. H. Rickles, Jr., and J. L. Day, "Electrodermal activity in non-palmar skin sites," *Psychophysiology*, vol. 4, pp. 421–435, Apr. 1968.
- [32] D. Shastri, A. Merla, P. Tsiamyrtzis, and I. Pavlidis, "Imaging facial signs of neurophysiological responses," *IEEE Trans. Biomed. Eng.*, vol. 56, no. 2, pp. 477–484, Feb. 2009.
- [33] D. C. Fowles, M. J. Christie, R. Edelberg, W. W. Grings, D. T. Lykken, and P. H. Venables, "Committee report. Publication recommendations for electrodermal measurements," *Psychophysiology*, vol. 18, pp. 232–239, May 1981.
- [34] S. Fisher, "Body image and asymmetry of body reactivity," *J. Abnorm. Psychol.*, vol. 57, pp. 292–298, Nov. 1958.
- [35] P. A. Obrist, "Skin resistance levels and galvanic skin response: Unilateral differences," *Science*, vol. 139, pp. 227–228, Jan. 18, 1963.
- [36] Y. Kuno, *Human Perspiration*. Oxford, U.K.: Blackwell Scientific Publications, 1956.
- [37] J. A. Allen, J. E. Armstrong, and I. C. Roddie, "The regional distribution of emotional sweating in man," *J. Physiol.*, vol. 235, pp. 749–759, Dec. 1973.
- [38] F. A. Fender, "Foerster's scheme of the dermatomes," *Arch. Neurol. Psychiatry*, vol. 41, pp. 688–696, 1939.
- [39] J. J. Keegan and F. D. Garrett, "The segmental distribution of the cutaneous nerves in the limbs of man," *Anat. Rec.*, vol. 102, pp. 409–437, Dec. 1948.
- [40] L. C. Johnson and A. Lubin, "Spontaneous electrodermal activity during waking and sleeping," *Psychophysiology*, vol. 3, pp. 8–17, Jul. 1966.
- [41] R. Edelberg, T. Greiner, and N. R. Burch, "Some membrane properties of the effector in the galvanic skin response," *J. Appl. Physiol.*, vol. 15, pp. 691–696, Jul. 1960.



Ming-Zher Poh (S'09) received the B.Sc. (Hons.) degree (*magna cum laude*) in electrical and computer engineering in 2005 from Cornell University, Ithaca, NY, and the S.M. degree in electrical engineering in 2007 from the Massachusetts Institute of Technology (MIT), Cambridge, where he is currently working toward the Ph.D. degree in electrical and medical engineering at the Harvard-MIT Division of Health Sciences and Technology (HST), Cambridge.

He was with the Massachusetts General Hospital (MGH) Center for Engineering in Medicine, where he was engaged in developing microfluidic biochips, and was with the MGH Department of Radiation Oncology, where he was involved in optimizing delivery of nanoparticles to tumors. Since 2008, he has been with the Affective Computing Group, MIT Media Laboratory. His current research interests include neurophysiology, wearable biosensors, and assistive technologies for neurological disorders such as epilepsy and autism.

Mr. Poh is also a Student Member of the Tau Beta Pi and an Associate Member of the Sigma Xi.



total-hip arthroplasties.

Nicholas C. Swenson is working toward the B.Sc. degree in biomedical engineering at the Massachusetts Institute of Technology (MIT), Cambridge.

He is currently a member of the Affective Computing Group, MIT Media Laboratory. From 2006 to 2007, he was with the Riverside Hospital, Newport News, VA, where he was engaged in research using hyperbaric therapy on wounds in diabetic patients. From 2007 to 2008, he was with the Mary Immaculate Hospital, Grafton, VA, where he was involved in research on the venous blood flow during different



Rosalind W. Picard (M'81–SM'00–F'05) received the Bachelors degree (with highest honors) in electrical engineering from Georgia Institute of Technology, Atlanta, in 1984, and the S.M. and Sc.D. degrees in electrical engineering and computer science from the Massachusetts Institute of Technology (MIT), Cambridge, in 1986 and 1991, respectively.

From 1984 to 1987, she was a member of the Technical Staff at AT&T Bell Laboratories, Holmdel, NJ. She was an Intern at Hewlett Packard, IBM, and Scientific Atlanta. She was a Consultant at a variety of companies, including Apple, iRobot, BT, and Motorola. She is currently a Professor of media arts and sciences at the MIT Media Laboratory, where she is also the Founder and the Director of the Affective Computing Group, and the Leader of a new Autism and Communication Technology Initiative. She is also Co-founder, Chairman, and Chief Scientist of Affectiva, Inc. She has authored or coauthored more than 200 scientific articles. She is best known for pioneering work in image and video content-based retrieval (the original Photobook system), for developing texture models and machine learning for their combination (Society of Models), and for her book *Affective Computing* (MIT Press, 1997), which helped launch a field by that name. Her current research interests include the development of technology to help people comfortably and respectfully measure and communicate affective information, and the development of models of affect that improve decision making and learning.

Prof. Picard is a member of the Association for Computing Machinery. She was a recipient of a Best Paper Prize from the IEEE International Conference on Advanced Learning Technologies in 2001.