

MIT Open Access Articles

*Closed Timelike Curves via Postselection:
Theory and Experimental Test of Consistency*

The MIT Faculty has made this article openly available. **Please share** how this access benefits you. Your story matters.

Citation: Lloyd, Seth, et al. "Closed Timelike Curves via Postselection: Theory and Experimental Test of Consistency." American Physical Society, 2011, 106:4, © 2011 The American Physical Society.

As Published: <http://dx.doi.org/10.1103/PhysRevLett.106.040403>

Publisher: American Physical Society

Persistent URL: <http://hdl.handle.net/1721.1/63096>

Version: Final published version: final published article, as it appeared in a journal, conference proceedings, or other formally published context

Terms of Use: Article is made available in accordance with the publisher's policy and may be subject to US copyright law. Please refer to the publisher's site for terms of use.



Closed Timelike Curves via Postselection: Theory and Experimental Test of Consistency

Seth Lloyd,¹ Lorenzo Maccone,¹ Raul Garcia-Patron,¹ Vittorio Giovannetti,² Yutaka Shikano,^{1,3} Stefano Pirandola,¹ Lee A. Rozema,⁴ Ardavan Darabi,⁴ Yasaman Soudagar,⁴ Lynden K. Shalm,⁴ and Aeprahim M. Steinberg⁴

¹*QIT, Massachusetts Institute of Technology, 77 Massachusetts Avenue, Cambridge, Massachusetts 02139-4307, USA*

²*NEST-CNR-INFM & Scuola Normale Superiore, Piazza dei Cavalieri 7, I-56126, Pisa, Italy*

³*Department of Physics, Tokyo Institute of Technology, 2-12-1 Oh-Okayama, Meguro, Tokyo, 152-8551, Japan*

⁴*CQIQC, IOS, Department of Physics, University of Toronto, Canada M5S 1A7*

(Received 12 May 2010; revised manuscript received 22 November 2010; published 27 January 2011)

Closed timelike curves (CTCs) are trajectories in spacetime that effectively travel backwards in time: a test particle following a CTC can interact with its former self in the past. A widely accepted quantum theory of CTCs was proposed by Deutsch. Here we analyze an alternative quantum formulation of CTCs based on teleportation and postselection, and show that it is inequivalent to Deutsch's. The predictions or retrodictions of our theory can be simulated experimentally: we report the results of an experiment illustrating how in our particular theory the “grandfather paradox” is resolved.

DOI: 10.1103/PhysRevLett.106.040403

PACS numbers: 03.65.Ud, 03.65.Ta, 03.67.-a, 04.62.+v

Although time travel is usually taken to be the stuff of science fiction, Einstein's theory of general relativity admits the possibility of closed timelike curves (CTCs) [1]. Following these paths through spacetime, a time traveler can go back in time and interact with her own past. The logical paradoxes inherent in time travel make it hard to formulate self-consistent physical theories of CTCs [2–6]. CTCs appear in many solutions of Einstein's field equations and any future quantum version of general relativity will have to reconcile them with the requirements of quantum mechanics. This Letter presents one particular route for resolving those paradoxes and analyzes a quantum description of CTCs by demanding that a CTC behaves like an ideal quantum channel. This self-consistency requirement gives rise to a theory of closed timelike curves via entanglement and postselection, P-CTCs. P-CTCs are based on the Horowitz-Maldacena “final state condition” for black hole evaporation [7], and on the suggestion of Bennett and Schumacher that teleportation could be used to describe time travel [8,9]. This Letter explores the consequences of this theory, showing (at a theoretical level) its inequivalence to Deutsch's quantum model for CTCs [2]. (There are also classical models for CTCs that we shall briefly discuss later in the article.) Elsewhere, we show that P-CTCs are consistent [10] with path-integral approaches to CTCs [6,11,12]. Moreover, because they are based on postselection [8,9], which can be probed experimentally, certain features of our P-CTC proposal are amenable to laboratory simulation. We present an experiment to simulate how the grandfather paradox might develop in a P-CTC: the postselected results are indistinguishable from what would happen when a photon is sent a few billionths of a second back in time to try to “kill” its former self. However, we cannot test whether a general relativistic CTC obeys our theory or not, nor can we experimentally discriminate between our theory and

Deutsch's: it is currently unknown whether CTCs exist in our Universe.

Deutsch's elegant quantum treatment of closed timelike curves [2] provides a self-consistent resolution of the various paradoxes of time travel by requiring simply that a system that enters such a curve in a particular quantum state ρ , emerges in the past in the same state [Fig. 1(a)] even after interacting with a “chronology-respecting” system in a state ρ_A through a unitary U . This translates into the consistency condition,

$$\rho = \text{Tr}_A[U(\rho \otimes \rho_A)U^\dagger]. \quad (1)$$

A ρ satisfying (1) exists: the term on the right is a completely positive map and has at least one fixed point [2].

Deutsch's self-consistency condition preserves the state of the time traveler, but not her correlations with the rest of the Universe [13]: the time traveler may (and almost certainly will) emerge into a different “past” from the

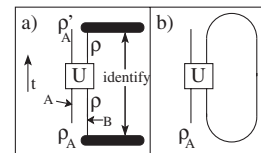

FIG. 1. (a) Deutsch's quantum description of CTCs is based on the consistency condition of Eq. (1), where the unitary U describes an interaction between a chronology-respecting system A , initially in the state ρ_A , and a system B in a CTC. Deutsch demands that the state ρ of B at the input and output of U be equal. Time goes from bottom to top in this and in the following diagrams. (b) P-CTC: postselected quantum teleportation is employed as a description of the closed timelike curve. The bottom curve \cup represents the creation of a maximally entangled state of two systems and the upper curve \cap represents the projection onto the same state.

one she remembers. Instead our P-CTC forces time travelers to travel to the past they remember. In fact, we demand that a generalized measurement made on the state entering the curve yields the same results, including correlations with other measurements, as would occur if the same measurement were made on the state emerging from it: the CTC should behave like an ideal quantum channel (even though, as we shall see, inside a CTC a proper definition of state cannot be given). Deutsch's CTCs do not exhibit this particular feature.

Teleportation [14] implements a quantum channel through the transfer of an unknown quantum state $|\psi\rangle$ between two parties (Alice and Bob) using a shared entangled state, the transmission of classical information, and a unitary transformation V on Bob's side. A curious feature of teleportation is that, whenever Alice's Bell measurement gives the same result it would when measuring the initial shared state, then Bob's unitary V is the identity. In this case, Bob possesses the unknown state even before Alice implements the teleportation. Causality is not violated because Bob cannot foresee Alice's measurement result, which is completely random. But, if we could pick out only the proper result, the resulting "projective" teleportation would allow us to travel along spacelike intervals, to escape from black holes [7], or to travel in time. We call this mechanism a projective or postselected CTC, or P-CTC.

The P-CTC [Fig. 1(b)] starts from two systems prepared in a maximally entangled state $|\Psi\rangle$ or " \cup ", and ends by projecting them into the same state $\langle\Psi|$ or " \cap ". Probabilities for events in the presence of a P-CTC are obtained by using ordinary quantum mechanics to calculate the *conditional* probabilities of the events given that a measurement on the final part of the CTC yields the state $|\Psi\rangle$. The probabilities for events in a P-CTC thus depend on the past and on the future.

If the probability for the outcome $|\Psi\rangle$ is zero, then the P-CTC cannot occur: our mechanism embodies in a natural way the Novikov principle [15] that only logically self-consistent events occur in the Universe. Note that also a classical version of our method can be easily described: it uses correlated classical states and postselection, and similarly obeys the Novikov principle. It is also easy to see that any measurement yields the same statistical results, including correlations with chronology-respecting systems, whether it is made on the time-traveling system entering the P-CTC or exiting from it. Because they are constructed by projecting out part of a pure state, P-CTCs take pure states to pure states. Deutsch's CTCs typically take pure states to mixtures.

Because they rely on postselection, P-CTCs share some properties with the weak value interpretation of quantum mechanics [16], notably that there is no unique way to assign a definite state to the system in a CTC at a definite time. Moreover, Hartle [12] showed that quantum

mechanics on closed timelike curves is nonunitary (indeed, it allows cloning) and requires events in the future to affect the past. He noted that the Hilbert space formalism for quantum mechanics might be inadequate to capture the behavior of closed timelike curves, and suggested a path-integral approach instead. In contrast to Deutsch's CTCs, P-CTCs are consistent with the "traditional" path-integral approaches to CTCs (e.g., see [5,6,11,12,17]): this can be shown using the normal path-integral self-consistency requirement that the classical paths that make up the path-integral have the same values of all variables (e.g., x and p) when they exit the CTC as when they enter [10]. Our approach coincides with Politzer's [11] path-integral treatment of fermions.

We now analyze how P-CTCs deal with time travel paradoxes. In the grandfather paradox, the time traveler goes back in time and kills her grandfather, so she cannot be born and cannot kill anyone: a logical contradiction. This paradox can be implemented through a quantum circuit where a "living" qubit (i.e., a bit in the state 1), goes back in time and tries to "kill" itself, i.e., flip to the state 0, see Fig. 2(a). There are many possible variants: i.e., any circuit in which the time travel gives rise to a logical contradiction. Deutsch's consistency condition (1) requires that the state is $\rho = (|0\rangle\langle 0| + |1\rangle\langle 1|)/2$, the only fixed point of the corresponding map. Note that if the CNOT before the bit flip measures a 0 then the CNOT afterwards measures a 1, and vice versa: the time traveler really manages to kill her grandfather. However, to preserve self-consistency, the 1 component (time traveler alive) that enters the loop emerges as the 0 component (time

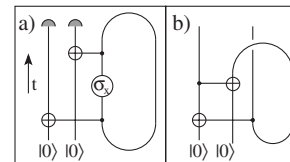

FIG. 2. (a) Grandfather paradox circuit. If we take 1 to represent "time traveler exists," and 0 to represent "she doesn't exist," then the NOT (σ_x) operation implies that if she exists, then she "kills her grandfather" and ceases to exist; conversely, if she does not exist, then she fails to kill her grandfather and so she exists. The difference between Deutsch's CTCs and our P-CTCs is revealed by monitoring the time traveler with two controlled-NOTs (CNOT): the two controlled bits are measured to determine the value of the time-traveling bit before and after the σ_x . Opposite values mean she has killed her grandfather; same values mean she has failed. Using Deutsch's CTCs, she always succeeds; using P-CTCs she always fails. (b) Unproved theorem paradox circuit. The time traveler obtains a bit of information from the future via the upper CNOT. She then takes it back in time and deposits a copy an earlier time in the same location from which she obtained it (rather, will obtain it), via the lower CNOT. The circuit is unbiased as to the value of the "proof" bit, so it automatically assigns that bit a completely mixed value, as it is maximally entangled with the one emerging from the CTC.

traveler dead), and vice versa. Thus, Deutsch's CTC preserves the mixed state, but not the identity of the components: measurements at the input and output yield different results.

The grandfather paradox is resolved differently by P-CTCs: the probability amplitude of the projection onto the final entangled state \cap is always null, namely, this event (and all similar logically contradictory ones) cannot happen. In any real-world situations, the σ_x transformation is not perfect. Then, replacing σ_x with $e^{-i\theta\sigma_x} = \cos\frac{\theta}{2}\mathbb{1} - i\sin\frac{\theta}{2}\sigma_x$ (with $\theta \approx \pi$), the nonlinear postselection amplifies fluctuations of θ away from π . This eliminates the histories plagued by the paradox and retains only the self-consistent histories where the kill fails (the unitary is $\mathbb{1}$ instead of σ_x), and the two output qubits have equal value: P-CTCs fulfill our self-consistency condition. No matter how hard the time traveler tries, her grandfather is tough to kill.

P-CTCs are based on postselected teleportation, so we can experimentally simulate certain features of their behavior (see also [18]): the necessary nonlinearity is introduced through postselection. To simulate the grandfather paradox we store two qubits in a single photon: one in the polarization degree of freedom, representing the "forward-traveling qubit," and one in a path degree of freedom, the "backward-traveling qubit"; see Fig. 3. Our single photons, with a wavelength of 941.7 nm, are coupled into a single-mode fiber from an InGaAs/GaAs quantum dot cooled to 21.5 K by liquid helium [19] and sent to the circuit. Using a Hanbury-Brown-Twiss interferometer, the $g^{(2)}(0)$ of the quantum dot emission was measured to be 0.29 ± 0.01 , confirming the single-photon character of the source. At the start of the circuit (\cup) we entangle the path and polarization qubits using a beam displacer (BD1), generating the Bell state $|\phi^+\rangle = (1/\sqrt{2})(|00\rangle + |11\rangle)$. To close the simulated CTC (\cap), we postselect on cases where $|\phi^+\rangle$ is detected: we use a CNOT with polarization (forward traveler) acting on path (backward traveler), followed by postselection on the now-disentangled qubits. The CNOT is implemented by a polarizing beam splitter that flips the path qubit conditioned on the polarization qubit. We then postselect on photons exiting the appropriate spatial port using a polarizer at 45° and an Andor iDus CCD camera cooled to 188 K. Within the loop, we implement a "quantum gun" $e^{i\theta\sigma_x}$ with a wave plate that rotates the polarization by an angle $\theta/2$. The accuracy of the gun can be varied from $\theta = \pi$ (the photon "kills" its past self) to $\theta = 0$ (it always "misses" and survives).

The teleportation circuit forms a polarization interferometer whose visibility was measured to be $93 \pm 3\%$ (see the inset in Fig. 4). To verify the operation of the teleportation circuit, all four Bell states $|\phi^\pm\rangle, |\psi^\pm\rangle$ were prepared and sent to the measurement apparatus: postselection on $|\phi^+\rangle$ behaved as expected yielding success probabilities of 0.96 ± 0.08 , 0.10 ± 0.11 , 0.02 ± 0.05 ,

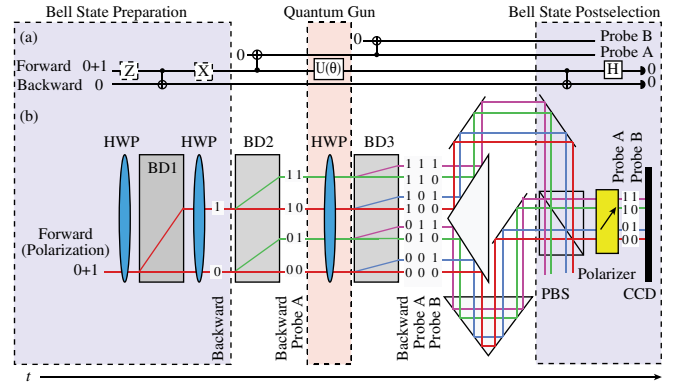

FIG. 3 (color online). Experiment to illustrate the P-CTC predictions of the grandfather paradox. (a) Quantum circuit. Using a CNOT gate sandwiched between optional Z and X gates, it is possible to prepare all of the maximally entangled Bell states. The Bell state measurement is implemented using a CNOT and a Hadamard. Each of the probe qubits is coupled to the forward qubit via a CNOT gate. (b) Experimental apparatus. The polarization and path degrees of freedom of single photons from a quantum dot are entangled via a calcite polarization-dependent beam displacer (BD1), implementing the CNOT. Half-wave plates (HWP) before and after BD1 implement the optional Z and X gates. To complete the teleportation, the postselection onto $|\phi^+\rangle$ is carried out by recombining the path degrees of freedom on a polarizing beam splitter (performing a CNOT gate between path and polarization) and then passing the photons through a calcite polarizer set to 45° and detecting them. A rotatable HWP acts as a quantum gun, implementing the unitary $U(\theta) = e^{-i\theta\sigma_x}$. Removable calcite beam displacers (BD2 and BD3) couple the polarization qubit to two probe qubits encoded in additional spatial degrees of freedom.

and 0.02 ± 0.05 for $|\phi^+\rangle, |\phi^-\rangle, |\psi^+\rangle$, and $|\psi^-\rangle$ inputs. After this verification, beam displacers (BD2 and BD3) were inserted, coupling the polarization qubit to two probe qubits encoded in additional path degrees of freedom of the photon. These probe qubits measure the state of the polarization qubit before and after the quantum gun is "fired." When the postselection succeeds (which simulates the time travel occurring), the state of the qubits is measured. If they are equal (00 or 11) the gun has failed to flip the polarization: the photon "survives," otherwise (01 or 10) the photon has "killed" its past self.

The state of the probe qubits, conditioned on the postselection succeeding, was measured for different values of θ (Fig. 4). The probes are never 01 or 10, which shows that "time travel cannot happen" unless the gun misfires, leaving the polarization unchanged and the probes in 00 or 11. Namely, suicidal photons in a CTC obey the Novikov principle: they cannot kill their former selves.

Our P-CTCs always send pure states to pure states: they do not create entropy. Hence, P-CTCs provide a distinct resolution to Deutsch's unproved theorem paradox, in which the time traveler reveals the proof of a theorem to a mathematician, who includes it in the same book from

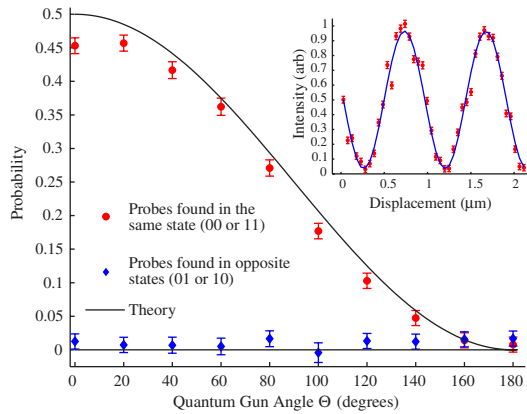

FIG. 4 (color online). Probability that the postselection simulating time travel succeeds and the probes are found in the same state (red circles) or in opposite states (blue diamonds). As the accuracy θ of the quantum gun increases from 0 to π , the probability that the teleportation succeeds decreases. Nonetheless, the probability that the probe qubits are found in either the 10 or 01 state (i.e., the kill succeeds) is 0.01 ± 0.04 . Solid curves correspond to theoretical predictions. The theory-experiment discrepancy is due to a $1.1 \pm 0.1^\circ$ mismatch between polarizers used for teleportation. The error bars are due to photon counting and background from the cooled CCD. Inset: the teleportation loop is a polarization interferometer with measured visibility $93 \pm 3\%$.

which the traveler has learned it (rather, will learn it). How did the proof come into existence? Deutsch adds an additional maximum entropy postulate to eliminate this paradox. By contrast, postselected CTCs automatically solve it [Fig. 2(b)] through entanglement: the CTC creates a random mixture of all possible “proofs.”

A user that has access to a closed timelike curve might be able to distinguish nonorthogonal states [20] and perform computations very efficiently: for pure state inputs, Deutsch’s CTCs permit the efficient solution of all problems in PSPACE [21] (that can be solved with polynomial space resources). (This may be useless for computation and state discrimination, because CTCs decorrelate the outputs of the computation from its inputs stored elsewhere [13].) In contrast, Aaronson’s results on postselection in computing imply that the P-CTCs can solve efficiently problems in the class probabilistic polynomial (PP) [22]. PP is putatively less powerful than PSPACE. P-CTCs do not decorrelate inputs from outputs, and can efficiently solve NP-complete problems, as they can perform any computation on a circuit of depth one.

We thank C. Bennett and D. Deutsch for discussions and suggestions. This work was supported by the Keck foundation, Jeffrey Epstein, NSF, ONR, DARPA, JSPS, NSERC, Quantum Works, CIFAR. R. Mirin and M. Stevens from the Optoelectronics Division at NIST provided the quantum dots for the experiment.

- [1] K. Gödel, *Rev. Mod. Phys.* **21**, 447 (1949); M. S. Morris, K. S. Thorne, and U. Yurtsever, *Phys. Rev. Lett.* **61**, 1446 (1988); B. Carter, *Phys. Rev.* **174**, 1559 (1968); W. J. van Stockum, *Proc. R. Soc. Edinburgh* **57**, 135 (1937); J. R. Gott, *Phys. Rev. Lett.* **66**, 1126 (1991).
- [2] D. Deutsch, *Phys. Rev. D* **44**, 3197 (1991).
- [3] S. W. Hawking, *Phys. Rev. D* **46**, 603 (1992).
- [4] S. Deser, R. Jackiw, and G. ’t Hooft, *Phys. Rev. Lett.* **68**, 267 (1992).
- [5] H. D. Politzer, *Phys. Rev. D* **46**, 4470 (1992).
- [6] S.-W. Kim and K. S. Thorne, *Phys. Rev. D* **43**, 3929 (1991).
- [7] G. T. Horowitz and J. Maldacena, *J. High Energy Phys.* **02** (2004) 008; U. Yurtsever and G. Hockney, *Classical Quantum Gravity* **22**, 295 (2005); D. Gottesman and J. Preskill, *J. High Energy Phys.* **03** (2004) 026; S. Lloyd, *Phys. Rev. Lett.* **96**, 061302 (2006).
- [8] C. H. Bennett, in *Proceedings of QUPON, Wien, 2005*, <http://www.research.ibm.com/people/b/bennetc/>.
- [9] G. Svetlichny, *arXiv:0902.4898*.
- [10] S. Lloyd *et al.*, *arXiv:1007.2615*.
- [11] H. D. Politzer, *Phys. Rev. D* **49**, 3981 (1994).
- [12] J. B. Hartle, *Phys. Rev. D* **49**, 6543 (1994).
- [13] C. H. Bennett *et al.*, *Phys. Rev. Lett.* **103**, 170502 (2009).
- [14] C. H. Bennett, G. Brassard, C. Crépeau, R. Jozsa, A. Peres, and W. K. Wootters, *Phys. Rev. Lett.* **70**, 1895 (1993).
- [15] J. Friedman *et al.*, *Phys. Rev. D* **42**, 1915 (1990).
- [16] Y. Aharonov, D. Z. Albert, and L. Vaidman, *Phys. Rev. Lett.* **60**, 1351 (1988).
- [17] J. L. Friedman, N. J. Papastamatiou, and J. Z. Simon, *Phys. Rev. D* **46**, 4456 (1992).
- [18] M. Laforest, J. Baugh, and R. Laflamme, *Phys. Rev. A* **73**, 032323 (2006).
- [19] R. P. Mirin, *Appl. Phys. Lett.* **84**, 1260 (2004).
- [20] T. A. Brun, *Found. Phys. Lett.* **16**, 245 (2003); T. A. Brun, J. Harrington, and M. M. Wilde, *Phys. Rev. Lett.* **102**, 210402 (2009); T. A. Brun and M. M. Wilde, *arXiv:1008.0433*.
- [21] S. Aaronson and J. Watrous, *Proc. R. Soc. A* **465**, 631 (2009).
- [22] S. Aaronson, *Proc. R. Soc. A* **461**, 3473 (2005).