

HB31

.M415

no.96-15





Digitized by the Internet Archive
in 2011 with funding from
Boston Library Consortium Member Libraries

<http://www.archive.org/details/changesinunemplo00acem>

DEWEY.
d

HB31
.M415
no.96-15

**working paper
department
of economics**

***CHANGES IN UNEMPLOYMENT AND WAGE INEQUALITY:
AN ALTERNATIVE THEORY AND SOME EVIDENCE***

Daron Acemoglu

96-15

June 1996

**massachusetts
institute of
technology**

**50 memorial drive
cambridge, mass.02139**



***CHANGES IN UNEMPLOYMENT AND WAGE INEQUALITY:
AN ALTERNATIVE THEORY AND SOME EVIDENCE***

Daron Acemoglu

96-15

June 1996

HB31
.M415
no. 96 15

MASSACHUSETTS INSTITUTE
OF TECHNOLOGY

JUL 18 1996

LIBRARIES

Changes in Unemployment and Wage Inequality: An Alternative Theory and Some Evidence

Daron Acemoglu
MIT

June 12, 1996

Abstract

This paper offers an alternative theory for the increase in unemployment and wage inequality experienced in the U.S. over the past two decades. In my model firms decide the composition of jobs and then match with skilled and unskilled workers. The demand for skills is endogenous and an increase in the proportion of skilled workers or their productivity can change the nature of equilibrium such that firms start creating separate jobs for the skilled and the unskilled. Such a change increases skilled wages, reduces unskilled wages and increases the unemployment rate of both skilled and unskilled workers. Although skilled workers are better-off as a result of this change, total social surplus can decrease. A testable implication which distinguishes this theory from others is derived and some evidence in support of this implication is provided.

JEL Classification: E24, J31, J64.

Keywords: Search, Matching, Unemployment, Wage Inequality, Job Structure.

• I thank Brian Bell, Peter Diamond, Steve Pischke, Jim Robinson, Robert Shimer and Jaume Ventura for useful comments, Matt Barmack for a lot of help with the PSID and John Johnson for excellent research assistance. I also received valuable comments from seminar participants at MIT, Nuffield College Oxford, CEPR Inequality Conference, NBER Inequality Group. Financial support from the World Economic Laboratory is gratefully acknowledged. Address For Correspondence: Dept. of Economics, MIT, Cambridge MA 02139. E-mail: daron@mit.edu

1. Introduction

Two trends are marked in the U.S. labor market since the early 1970s: first, unskilled wages have fallen in absolute levels while wages for skilled workers have risen; second, unskilled unemployment has increased substantially. There is widespread agreement among labor economists that increased demand for skills is a very important part of the story [e.g. Katz and Murphy, 1992, Berman, Bound and Grilliches, 1994]. However, irrespective of whether the relative demand for skilled workers increased due to skill-biased technological change or due to increased globalization, the absolute decline of wages at the bottom of the distribution by as much as 30% in real terms is not easily explained without the introduction of additional features.¹ Perhaps more importantly, both the trade and technology explanations imply that because the demand for skilled workers has increased, their unemployment rates should have decreased. In contrast, the unemployment rates for workers of all education groups have risen over the past two decades.²

This paper offers an alternative theory which explains both major trends through a new mechanism. I suggest that a change in the structure of jobs can simultaneously reduce unskilled wages, raise skilled wages and increase unemployment for both skilled and unskilled workers. The driving force for the change in the structure of jobs can be skill-biased technical change in which case the model I present can be viewed as a new and powerful propagation mechanism for a familiar shock. However, another and more directly observable shock also plays the same role in this model: an increase in the proportion of skilled workers in

¹For instance, the presence of some scarce factor whose price increases as a result of the technological change would lead to this type of conclusion. But in general, it is not clear what the scarce factor is.

²See OECD (1994), Murphy and Topel (1987), Nickell and Bell (1995). In 1970, the unemployment rate for male workers with less than 4 years of high school was 4.0%, for those with 4 years of high school was 2.4% while the unemployment for males with more than 4 years of college stood at 1.1%. In 1991, the unemployment rate for these three groups was respectively 13.4%, 7.7% and 3.2%. Similarly, the average unemployment rates between 1992-94 for male workers with no high school degree was 13.9%, for those with less than a bachelor degree was 6% and for male college graduates it stood at 3.2% [Statistical Abstracts of the U.S., 1995, Table 662].

the labor force. Despite the unprecedented increase in the proportion of skilled and highly educated workers in the labor force during the 70s³, previous research has discarded changes in the composition of the labor force as an explanation for increased wage inequality based on the observation that the relative employment and wages of skilled workers moved in the same direction. This observation does not contradict my theory since a change in the composition of the labor force *induces* a change in the structure of jobs and an *even larger increase* in the relative demand for skills, thus affecting relative wages and employment in the same direction.

To illustrate the main mechanism proposed in this paper, consider a labor market consisting of two groups; the skilled and the unskilled. The skilled are naturally more productive but the unskilled can be trained to perform the same jobs as the skilled. Firms in this economy determine the relative demand for skills by deciding what kind of jobs to open and then search for workers. Suppose they have a choice between three types of jobs; unskilled, middling and skilled. If they open skilled jobs, they have to find a skilled worker, whereas with a middling job unskilled workers are also acceptable, thus vacancies can be filled much faster and recruiting costs will be lower. Since most jobs are open to both skilled and unskilled workers and most vacancies are filled rapidly, unemployment in this labor market is low. Moreover, wage inequality is limited because skilled and unskilled workers are working in the same jobs, thus skilled workers are employed at *lower* physical to human capital ratios than the unskilled, and this *compresses* the wage differences between these two groups [see sections 2.2 and 3 for details on this claim]. This equilibrium with middling jobs, low unemployment and limited wage inequality has some affinity to the situation in the 1950s and 1960s when the labor market was relatively tight and firms were keen on filling their jobs fast.

Now consider two possible changes: (1) the proportion of skilled workers increases, and/or (2) the productivity of skilled workers increases relative to unskilled workers. After either of these two changes it will become profitable for many firms to switch from middling to skilled jobs because it is easier to fill these positions (as there are more skilled workers in the unemployment pool), or because the productivity of skilled positions has increased. In turn, other firms

³For example, the proportion of male high-school graduates entering college reached a peak of 65% in 1969 (see Freeman, 1976). The proportion of workers in the labor force with some college increased from 25.9% to 47.6% from 1970 to 1991 (Statistical Abstracts of the U.S., 1995, Table 629, see also Katz et al, 1995).

will find it profitable to open 'low-quality' jobs for the unskilled workers who can no longer get the middling jobs (e.g. low-skill service jobs versus manufacturing jobs). What are the implications? First, skilled unemployment will increase because anticipating the availability of high quality jobs, skilled workers become more 'choosy'. Second unskilled unemployment will increase due to the same reason. Third, skilled wages will increase due to the higher quality of the jobs they are now obtaining. Fourth, unskilled wages will fall since they will be employed in worse jobs.

In support of this description of the major changes in the U.S. labor market over the past two decades, Levy and Murnane (1995) in their case studies of a number of companies including Chrysler, Honda of America and Northwest Mutual find that during the 1960s and the early 1970s these companies were very lenient in their recruiting practices, and any worker who satisfied some minimum requirement was hired. However, during the late 1980s, these firms started using very different recruitment techniques; in particular, they had substantially higher requirements, turned down a large number of workers and expended relatively large resources to find the right workers including lengthy interviews, and English and Math tests to determine cognitive skills.

Therefore, the explanation offered in this paper for the major trends in the U.S. labor market⁴ is that *in response to the changes in the composition of the workforce and technology, the structure of jobs and the equilibrium demand for labor change*. It is particularly important to emphasize that when the driving force is the change in the composition of the workforce, there is no exogenous change in technology, but a large restructuring of demand for labor. The composition of jobs may actually '*overshoot*' the change in the composition of the workforce, and as a consequence, there could be a severe contraction in the demand for unskilled workers. As a result, the increase in the proportion of skilled workers, which has traditionally been thought of as a counteracting force to the rise in wage inequality, becomes a driving force or at least a contributing factor. Similarly, a small change in the relative productivity of skilled workers can cause a large adjustment on the demand side, depressing the job market opportunities for unskilled workers.

⁴As it is well known there are similar trends in other OECD countries and the differences between Europe and the U.S. are very informative. However, in this paper I will not discuss the experience of other countries. In Acemoglu (1996) and (1995b), I discuss how a similar model with a number of different features can account for some of the differences between Europe and the U.S.

These results are caused by the non-convexity introduced by the transaction costs of search, and they would never occur in a competitive equilibrium. Finally, in contrast to all other explanations offered for the increase in wage inequality, this approach explains (irrespective of whether the driving force is (1) or (2)) why the unemployment of the skilled increases and why there is a fall in the absolute level of unskilled wages.

An interesting welfare conclusion follows from this model. Changes in the composition of jobs towards more ‘separation’ across types may reduce welfare because unskilled workers no longer receive rents. Although as in the standard explanations the increase in wage inequality is the result of the changing demand for skilled workers, this change can be associated not only with more inequality but also with more inefficiencies in the allocation of resources.

A word of interpretation is necessary at this stage. It is not always easy to determine which features of the data a model best captures. Since the results are driven by search costs — costs that firms have to incur in finding the right workers —, it may be conjectured that the model only has relevance to *within education-group inequality*. Underlying this view is the argument that if a firm needs workers with some observable skills, such as a college degree, it can open a vacancy asking only college graduates to apply, thus the cost of finding a college graduate would be independent of the composition of the workforce with respect to observable characteristics. First of all, this interpretation would not limit the interest of the analysis since as Juhn, Murphy and Pierce (1993) conclude the largest component of the increase in wage inequality is in the increased ‘price of unobserved skills’. The characteristics not observed by the econometrician are also difficult to specify in a job description and thus the mechanism suggested here will apply. Furthermore, the extension in section 5 demonstrates that the results apply even with a small degree of ‘randomness’ and frictions in the matching technology. Moreover, in the real world the qualifications are not simply college graduates or high school drop-outs, some firms will always find it profitable to ‘pool’ across types; for instance, given the evidence in Levy and Murnane (1995) and Barron et al (1985) that firms spend considerable resources in their recruitment activities, it is quite plausible to suppose that a firm searching for a worker with 13 years of schooling will often not turn down someone with 12.5 years if workers with 13 years of schooling are scarce. On the other hand, the same firm may decide to wait for workers with 13 years of schooling when these more educated workers are abundant in the unemployment pool.

The model I use builds on the work of Diamond (1982), Jovanovic (1979), Mortensen (1982), and Pissarides (1990). These papers all deal with ex ante homogenous agents, and in this respect my work is most closely related to Sattinger (1995), Shimer and Smith (1996) and Burdett and Coles (1995), all of which analyze search and matching models with ex ante heterogeneity. The first two deal with models of transferable utility and the last with non-transferable utility. However, differently from all these papers and along the lines of Acemoglu (1995a,b), I endogenize the composition of jobs in the economy which means the firms are allowed to choose their 'types'. This is an important innovation as it is the most natural reason for why jobs would be heterogeneous, and more importantly, it enables the analysis of the changing structure of jobs. Moreover, this added feature simplifies the analysis and as a result the equilibria can be characterized fully and a number of results such as the multiplicity of equilibria and welfare results are derived analytically.

Kremer and Maskin (1996) use a model of competitive labor markets with managers and workers to argue that the increase in wage inequality is caused by the changing matching patterns. In their model, when the gap between skilled and unskilled workers is limited, skilled workers become managers and employ the unskilled workers, but an increase in the skill gap makes it more profitable to concentrate high skilled workers in the same firms and unskilled workers in others. As well as the mechanism and the driving forces, the welfare implications of the two models are very different. Other related papers are Acemoglu (1995a,b) and Davis (1995) who also endogenize the composition of jobs and Saint-Paul (1993) who analyzes the implications of skill-biased technological change on wages and unemployment in a two sector search model. None of these papers share the key results of this paper, that wage and unemployment inequality depend on the composition of the labor force through changes in the structure of jobs.

The plan of the paper is as follows. The next section lays out the basic environment, preferences and technology and derives the competitive allocation. Section 3 analyzes the search equilibrium. Section 4 derives the social planner's choice subject to the same search frictions. Section 5 generalizes the results to other matching technologies. Section 6 derives a testable implication not shared by alternative theories and provides some micro evidence in support of this prediction. Section 7 concludes and the Appendix contains the proofs.

2. The Basic Setup

2.1. The Environment

The economy consists of a continuum of workers of measure 1. Time is discrete and infinite and workers are potentially infinitely lived. Each worker faces a probability of death equal to δ in every period, but population is constant as there is a flow δ of new workers in every period. I assume that a proportion ϕ of workers born in every period are unskilled and a proportion $1 - \phi$ of the workers are skilled. There is no discounting in this economy (other than due to the possibility of death) and all workers are risk-neutral and maximize their expected life-time earnings. On the other side of the market there is a larger continuum of firms. Firms maximize expected income without discounting.

Production requires a worker, a production site and a firm with capital. There is a continuum of sites of measure 1, and as a result there will always be the same number of active firms and workers looking for a productive relation (which is a convenient normalization). Since sites may be in short demand, they will rent at a price c and this price, determined in equilibrium, will ensure that firms make zero profits.

All firms have access to the same production technology given as

$$y = Ak^{1-\alpha}h^\alpha,$$

where k is the physical capital of the firm and h is the human capital level of the worker. Skilled workers have human capital $h_2 = \eta > 1$ and unskilled workers have $h_1 = 1$. The crucial assumption is that firms have to choose their level of physical capital before they know which worker will be their match (see Acemoglu, 1995a), and this choice is *irreversible*. The price of capital is normalized to 1 and this is the amount the firm has to pay per unit of capital every period in which it is active.

The fact that the physical capital decision is irreversible implies that a firm that has hired a level of capital k_2 this period cannot reduce or increase its physical capital next period; it is stuck with k_2 and as long as it is active it will have to pay k_2 as the cost of capital and use this amount of physical capital in production. As a motivation imagine that a firm buys a machine with a certain amount of physical capital embedded in it or specifically designed for a particular 'sector' and it can never use any other machine. During every period in which this machine is

used, costs of depreciation and repair proportional to the amount of capital will be incurred.

Finally, after a firm and a worker meet and agree, the match continues until the worker dies at which point the firm also disappears. The site is rented in the next period by a new firm which then chooses its physical capital level.

2.2. The Walrasian Allocation

First, assume that the labor market is frictionless. Firms again choose their physical capital before they arrive in the labor market. Competition for workers yields marginal pricing, so for a worker with human capital h working with a firm of physical capital k , total wage earnings are:

$$w(h) = \alpha A k^{1-\alpha} h^\alpha.$$

Since human and physical capital are complements, high physical capital firms will be willing to pay more for the skilled workers [see Sattinger, 1993 for a survey of assignment models]. It follows that in a steady state equilibrium there will be two types of firms; a proportion ϕ with physical capital k_1 that employ the unskilled workers, and a proportion $1 - \phi$ with physical capital k_2 that employ the skilled workers. The profits of these two types of firms are given as:

$$\Pi_i(k_i) = A k_i^{1-\alpha} h_i^\alpha - w_i - k_i$$

Then, equilibrium physical capital levels are:

$$k_1 = [(1 - \alpha)A]^{1/\alpha},$$

$$k_2 = [(1 - \alpha)A]^{1/\alpha} \eta,$$

and both types of firms make zero profits. The significant point is that $k_1 = \frac{k_2}{\eta}$; that is, unskilled and skilled employees work at the same physical to human capital ratio. As a result of marginal product pricing, the ratio of wages for these two groups is precisely $\frac{w_2}{w_1} = \eta$. This is due to the constant returns to scale production function but it constitutes a useful benchmark. Also in this economy there is no (end-of-period) unemployment.

Two comparative static results immediately follow. First, a 1% increase in η is translated directly into a 1% increase in the wage ratio $\frac{w_2}{w_1}$, and if we interpret an

increase in η as skill-biased technological change (skilled workers becoming more productive relative to the unskilled), the absolute level of unskilled wage remains unchanged. Second, a change in ϕ changes the number of high physical capital jobs, but the wage gap is not affected. Therefore, although the composition of jobs changes in response to the change in ϕ , there is no *overshooting*: the effective demand for skilled workers remains constant, and hence relative wages are unchanged. These results will be important for future comparison.

3. The Search Equilibrium

Let me now dispose of the Walrasian auctioneer. Workers are matched to firms via a *random matching technology*. Since there are the same number of active firms and workers, I assume that every worker meets a firm in every period and vice versa. The randomness of the matching technology implies that each worker has a constant probability of meeting each firm regardless of his human capital [thus, a skilled worker is not more likely to meet a high physical capital firm]. This is an extreme assumption often adopted in the search literature because the alternatives are much harder to deal with [e.g. Sattinger, 1995, Burdett and Coles, 1995]. Section 5 will show that relaxing this assumption does not change the results.⁵

Because costly search removes marginal pricing, I will use bargaining for wage determination which is common in the search literature. However, rather than adopt Nash Bargaining, this paper uses the explicit strategic bargaining as in Shaked and Sutton (1984) or Binmore, Rubinstein and Wolinsky (1986). Such bargaining has sounder microfoundations than axiomatic Nash bargaining and more importantly, it simplifies the expressions [see Acemoglu (1995a) Appendix A]. According to this wage rule, the worker obtains a proportion β of the *total surplus* unless the outside option of the firm or that of the worker is binding, in which case the party whose outside option binds receives its outside option. Total

⁵An alternative formulation that would preserve the qualitative results is as follows: all workers are observationally equivalent and firms need to interview workers in order to elicit their types. However, this interview is not perfect so that an unskilled worker can appear as skilled, thus the unskilled always have an incentive to apply to all the vacancies that they encounter. Firms can either decide to interview these workers and hire those who pass or accept all workers who contact them. Which strategy is more profitable will naturally depend on the proportion of the two types in the population, and an increase in the proportion of high types will make the firms more willing to employ costly testing.

net output is denoted by y , the outside option of the worker by \bar{w} , and the outside option of the firm by $\bar{\pi}$, then the wage rate will be $w = \min \{ \max \{ \beta y, \bar{w} \}, y - \bar{\pi} \}$. In words, as long as the outside option of the firm and the worker are not binding, the worker obtains a proportion β of the total surplus, and if the outside option of one of the parties binds, he (it) obtains his (its) outside option. By the free-entry condition, the outside option of firms $\bar{\pi}$ will be fixed at zero, thus the wage rule can be taken to be $y = \max \{ \beta y, \bar{w} \}$.

A steady state allocation⁶ in this economy will consist of an investment level for all firms denoted by the mapping $K : [0, 1] \rightarrow \mathbb{R}^+$ which determines the level of capital for firm $i \in [0, 1]$ that is active; outside options for skilled and unskilled workers, \bar{w}^s and \bar{w}^u ; and total unemployment for skilled and unskilled workers, U^u and U^s . Firm i 's profit is given by:

$$\Pi_i(k_i) = \frac{(1 - \delta)}{\delta} \left(\begin{array}{l} \lambda \max \langle \min \{ (1 - \beta)(Ak_i^{1-\alpha} - k_i), Ak_i^{1-\alpha} - \bar{w}^u \}; 0 \rangle \\ + (1 - \lambda) \max \langle \min \{ (1 - \beta)(Ak_i^{1-\alpha} - k_i), Ak_i^{1-\alpha}\eta^a - \bar{w}^s \}; 0 \rangle \end{array} \right) \quad (3.1)$$

where λ is the proportion of unskilled workers and $(1 - \lambda)$ is the proportion of skilled workers looking for a job. It is straightforward to see that $\lambda = \frac{U^u}{U^u + U^s}$, since U denotes the beginning-of-period unemployment (which is different from end-of-period unemployment).

Let me briefly explain (3.1). The firm will always meet a worker because there is an equal number of firms and workers looking for a match. With probability λ , the worker will be unskilled. After this match three things can happen: (i) there is no employment relation in which case the firm gets 0; (ii) there is an employment relation and the outside option of the worker is not binding, then the firm obtains $(1 - \beta)(Ak_i^{1-\alpha} - k_i)$; and (iii) the outside option of the worker binds but it is still profitable to form an employment relation, and in this case the firm obtains $Ak_i^{1-\alpha} - k_i - \bar{w}^u$. With probability $1 - \lambda$, the firm meets a skilled worker and the same three possibilities are available. Note also that the assumption used in writing this expression is that the firm does not have to pay for capital before production starts, thus bargaining takes place over the net profitability of the match. However, the firm commits to a capital level before the match and cannot

⁶Non-steady-state allocations can also be characterized with more work and notation and I leave those out to save space and notation. Since I am only dealing with steady-states, I ignore the option to destroy jobs in the future.

change this level of capital investment.⁷ Finally, the whole term is multiplied by $\frac{1-\delta}{\delta}$ because the relationship comes to an end at the rate δ , and this is the only reason why the future is discounted.

A *Steady State Search Equilibrium* is defined by the following conditions:

1. Outside options for skilled and unskilled workers \bar{w}^s and \bar{w}^u are determined optimally.
2. Firm i and worker j form a match if and only if $Ak_i^{1-\alpha}h_j^\alpha - k_i \geq \bar{w}^j$ where h_j is the human capital of worker j and \bar{w}^j is his outside option.
3. Given (1) and (2), k_i is chosen to maximize firm i 's profits as given by (3.1) for all $i \in [0, 1]$.

3.1. The Pooling Allocation

I start with an allocation which I call, with some abuse of terminology, *the pooling allocation*.⁸ In this allocation all firms choose the same level of capital k_p and accept any worker, and all workers accept all firms. Formally, (1) $k_i = k_p, \forall i \in [0, 1]$; (2) $Ak_p^{1-\alpha}\eta^\alpha - k_p \geq \bar{w}^s$; and (3) $Ak_p^{1-\alpha} - k_p \geq \bar{w}^u$.

Since all firms are the same, in this allocation the outside option (reservation returns) of workers do not bind. Then, in steady state the expected per period profits of a firm can be written as:

⁷For instance, once the firm chooses investment equal to k , it has two options: shut-down at no cost or continue to function at cost k per period. There are a number of alternative modelling strategies that could have been adopted without changing the results. The formulation in the text is chosen as it is the least algebra and notation intensive, and more importantly, it makes the comparison with Walrasian Equilibrium most straightforward. A natural alternative would be the following: the firm buys the capital at a price R per unit and then meets the worker and bargains. In every period that the capital is used, the firm pays a depreciation proportional to its capital stock. In this case, because the physical capital of the firm is sunk before wage negotiations, we have $w = \beta Ak^{1-\alpha}h^\alpha$. Moreover, the firm now incurs the cost of physical investment even when it does not meet a worker. In this case the investment levels would have to be multiplied by $\frac{(1-\beta)^{1/\alpha}}{((1-\beta)(1-\delta)+\delta R)}$ and the profit levels by $\frac{(1-\beta)^{\frac{\alpha-1}{\alpha}}}{((1-\beta)(1-\delta)+\delta R)}$. Further, in the welfare analysis, there would be another reason for inefficiency. The firm would underinvest in physical capital as in Grout (1984) and Acemoglu (1995a). Abstracting from this inefficiency makes the more novel sources of inefficiency in this setting more transparent.

⁸Recall: there are no informational asymmetries. The term pooling is used to capture the fact that both skilled and unskilled workers are working in the same type of jobs.

$$\Pi_p = \frac{(1 - \delta)(1 - \beta) [(1 - \phi)Ak_p^{1-\alpha}\eta^\alpha + \phi Ak_p^{1-\alpha} - k_p]}{\delta}.$$

A firm immediately finds an employee because it accepts both types. In steady state all workers are immediately accepted, thus $U^u = \delta\phi$ and $U^s = \delta(1 - \phi)$, that is, only new workers look for a job (end-of-period unemployment rates are equal to zero as in the Walrasian allocation). Therefore, with probability $\lambda = \phi$ the firm produces $Ak_p^{1-\alpha} - k_p$ until the job is destroyed and with probability $(1 - \phi)$, it meets a skilled worker, and the per period profits are equal to $Ak_p^{1-\alpha}\eta^\alpha - k_p$. Then:

$$k_p = \{[\phi + (1 - \phi)\eta^\alpha](1 - \alpha)A\}^{1/\alpha}, \quad (3.2)$$

and

$$\Pi_p = \frac{\alpha(1 - \beta)(1 - \delta) \{[\phi + (1 - \phi)\eta^\alpha](1 - \alpha)A\}^{1/\alpha}}{(1 - \alpha)\delta}. \quad (3.3)$$

Finally, the cost of hiring a site will be $c = \delta\Pi_p$ as each site has to receive the expected discounted present value of a vacant firm.

3.2. Deviation from the pooling allocation

In order to determine whether and when the pooling allocation can be an equilibrium, returns to potential deviations need to be calculated. It should be clear that the most profitable deviation is one where a firm decides to turn down all unskilled workers and accept only the skilled. Thus consider firm $i = d$ deviating and adopting this strategy. Then:

$$\Pi_d = \frac{(1 - \phi)(1 - \delta)(1 - \beta)[Ak_d^{1-\alpha}\eta^\alpha - k_d]}{\delta}.$$

The cost of deviating is that instead of finding a worker with probability 1, the firm only gets a worker with probability $(1 - \phi)$, otherwise it proceeds to the next period as a vacant firm (zero return). The benefit is that knowing it will only work with high skilled workers, the firm can choose a higher level of physical capital (i.e. a job specifically designed for a high skill worker). This gives:

$$k_d = [(1 - \alpha)A]^{1/\alpha} \eta, \quad (3.4)$$

and

$$\Pi_d = \frac{(1 - \phi)(1 - \delta)(1 - \beta)\alpha [(1 - \alpha)A]^{1/\alpha} \eta}{(1 - \alpha)\delta}. \quad (3.5)$$

Thus the condition for the pooling allocation to be an equilibrium is $\Pi_p \geq \Pi_d$ or

$$\eta^\alpha \leq \frac{\phi}{(1 - \phi)^\alpha - (1 - \phi)}. \quad (3.6)$$

Hence (proof omitted):

Lemma 1. *If $\eta^\alpha \leq \frac{\phi}{(1 - \phi)^\alpha - (1 - \phi)}$, there exists a pooling equilibrium in which all firms choose k_p as given by (3.2) and all workers immediately find jobs.*

There are three important features to be noted about this equilibrium. First, in contrast to the Walrasian allocation of section 2.2, here all workers are in the same type of jobs, and as a result highly skilled labor works at a physical to human capital ratio of $\frac{k_p}{\eta}$ whereas the ratio for low skill workers is k_p . As a result, skilled-unskilled wage ratio is equal to $\frac{w_2}{w_1} = \eta^\alpha$, thus wage differences are *compressed*. Second, there is no unemployment for either group. Third, unskilled workers benefit from being in the same labor market as the skilled workers. Anticipating to meet a skilled worker some of the time, firms invest in a larger stock of physical capital than they would have done in the absence of skilled workers, and this increases the return to unskilled workers (see Acemoglu, 1995a).

3.3. The Separating Allocation

The alternative to pooling is *the separating allocation*. Firms open either high or low physical capital jobs, and low physical capital firms are turned down by skilled workers while high capital firms turn down unskilled workers. Formally, (1) $\exists \mu \geq 0$ such that $k_i = k_1 \forall i \leq \mu$ and $k_i = k_2 \forall i > \mu$; (2) $Ak_1^{1-\alpha} - k_1 \geq \bar{w}^u$ and $Ak_1^{1-\alpha}\eta^\alpha - k_1 < \bar{w}^s$; and (3) $Ak_2^{1-\alpha}\eta^\alpha - k_2 \geq \bar{w}^s$ and $Ak_2^{1-\alpha} - k_2 < \bar{w}^u$. Thus, two levels of physical capital (k_1 and k_2) and the proportion of vacant firms choosing each level (μ) need to be determined, and it has to be ensured that high physical

capital firms do not accept unskilled workers and skilled workers do not accept low physical capital firms

With a similar reasoning to (3.5), profits for high and low capital firms are:

$$\begin{aligned}\Pi_1 &= \frac{\lambda(1-\delta)(1-\beta)[Ak_1^{1-\alpha} - k_1]}{\delta}, \\ \Pi_2 &= \frac{(1-\lambda)(1-\delta)(1-\beta)[Ak_2^{1-\alpha}\eta^\alpha - k_2]}{\delta},\end{aligned}$$

where the difference from (3.5) is that the proportion of unskilled workers in the unemployment pool, λ , is no longer equal to ϕ and is endogenously determined in equilibrium. Also note that since we are in a steady state allocation, future job opportunities are the same as now, therefore, outside options will not bind. Straightforward maximization gives the physical capital choices of high and low firms as

$$\begin{aligned}k_1 &= [(1-\alpha)A]^{1/\alpha}, \\ k_2 &= [(1-\alpha)A]^{1/\alpha}\eta.\end{aligned}\tag{3.7}$$

Thus;

$$\Pi_1 = \frac{\lambda(1-\delta)(1-\beta)\alpha [(1-\alpha)A]^{1/\alpha}}{(1-\alpha)\delta},\tag{3.8}$$

$$\Pi_2 = \frac{(1-\lambda)(1-\delta)(1-\beta)\alpha [(1-\alpha)A]^{1/\alpha}\eta}{(1-\alpha)\delta}.\tag{3.9}$$

This allocation can be an equilibrium only if $\Pi_1 = \Pi_2$, otherwise all vacant firms would like to choose one or the other physical capital level (a corner solution with $\Pi_1 < \Pi_2$ and $\mu = 0$ is also possible). Equation (3.8) and (3.9) give:

$$\lambda = \frac{\eta}{1+\eta}.\tag{3.10}$$

Next the composition of jobs in steady state needs to be determined. This can be done straightforwardly from the steady state accounting equations for skilled and unskilled unemployment. By definition;

$$\begin{aligned}\phi\delta &= [\delta + \mu(1 - \delta)] U^u \\ (1 - \phi)\delta &= [\delta + (1 - \mu)(1 - \delta)] U^s\end{aligned}\tag{3.11}$$

The left-hand side of the top equation is entry into unskilled unemployment each period and the right hand side is the exit from unemployment: there are U^u unemployed unskilled workers and a proportion δ of these leave unemployment because they die. The remaining workers all get matched but only a proportion μ who meet a low capital firm exit unemployment. The bottom equation is similarly defined. Noting that $\frac{U^u}{U^s} = \frac{\lambda}{1-\lambda}$, the second equation linking λ to μ is obtained:

$$\frac{\phi}{1 - \phi} = \frac{\delta + (1 - \delta)\mu}{\delta + (1 - \delta)(1 - \mu)} \frac{\lambda}{1 - \lambda}.\tag{3.12}$$

(3.12) together with (3.10) and (3.7) describes the separating equilibrium.⁹ Note that unemployment for both groups is higher than in the pooling equilibrium (or end-of-period unemployment is positive). Furthermore, because firms get higher rents from employing a skilled worker, there will be relatively more demand for the skilled. To see this effect clearly note that when $\phi = \frac{1}{2}$ and $\eta = 1$, skilled and unskilled unemployment are equal, and as η increases, skilled unemployment falls and unskilled unemployment increases (of course at $\eta = 1$, the equilibrium will not be separating, also recall that u denotes total unemployment, not unemployment rate, in general, the unemployment *rate* of the unskilled divided by the unemployment *rate* of the skilled is always increasing in η).

3.4. Deviation From the Separating Allocation

The optimal deviation will be to choose a physical capital level \bar{k} and accept all workers. The benefit is that a job will be formed with probability 1 instead of $(1 - \lambda)$. However, a disadvantage is that the firm will not design the jobs specifically for the skilled workers, and profits from skilled workers will be lower.

⁹More explicitly:

$$\mu = \max \left\{ \frac{\phi - (1 - \phi)\delta\eta}{(1 - \delta)[\phi + (1 - \phi)\eta]}, 0 \right\}.$$

Note also that the outside option of a high skill worker may be binding in this case because the deviant chooses a lower level of physical capital than the high capital firms and thus a proportion β of the output of this firm may be less than what a skilled worker can expect to get by remaining unemployed. The outside option of a skilled worker \bar{w}^s is equal to his expected earning from waiting for a skilled job, thus:

$$\bar{w}^s = (1 - \delta)(1 - \mu)w_2 + (1 - \delta)^2\mu(1 - \mu)w_2 + (1 - \delta)^3\mu^2(1 - \mu)w_2 + \dots$$

$$\bar{w}^s = \frac{(1 - \mu)(1 - \delta)\beta (Ak_2^{1-\alpha}\eta^\alpha - k_2)}{1 + (1 - \delta)\mu} \quad (3.13)$$

Lemma 2. (i) If $\beta (A\bar{k}^{1-\alpha}\eta^\alpha - \bar{k}) \geq \bar{w}^s$, then a separating equilibrium does not exist.

(ii) There exists $\bar{\eta}$ such that for $\eta < \bar{\eta}$, a separating equilibrium does not exist.

Part (i) of the Lemma establishes that when the outside option of the worker does not bind, a deviation from the separating allocation will always be profitable. The second part (ii) follows immediately, with $\bar{\eta}$ defined as the relative skill of the skilled workers such that the outside option of the skilled workers just binds. This Lemma suggests that for a separating equilibrium we should look at the region of $\eta > \bar{\eta}$, i.e. in the region where the outside option of a skilled worker would bind when he meets a deviant firm. In this region, since the deviant has to pay \bar{w}^s to skilled workers, its profit level is:

$$\tilde{\Pi}(\bar{k}) = \frac{(1 - \delta) \left(\lambda(1 - \beta)[A\bar{k}^{1-\alpha} - \bar{k}] + (1 - \lambda) [A\bar{k}^{1-\alpha}\eta^\alpha - \bar{k} - \bar{w}^s] \right)}{\delta}.$$

Simple maximization gives the optimal deviation from the separating allocation as:

$$\bar{k} = \left[\frac{A(1 - \alpha)[(1 - \lambda)\eta^\alpha + \lambda(1 - \beta)]}{\lambda(1 - \beta) + (1 - \lambda)} \right]^{1/\alpha}. \quad (3.14)$$

Substituting for \bar{k} in the profit function gives:

$$\bar{\Pi} = \frac{\alpha(1-\delta)}{\delta(1-\alpha)} \left[\frac{A(1-\alpha)[(1-\lambda)\eta^\alpha + \lambda(1-\beta)]}{\lambda(1-\beta) + (1-\lambda)} \right]^{1/\alpha} \quad (3.15)$$

$$\frac{(1-\lambda)(1-\mu)(1-\delta)\beta A [(1-\alpha)A]^{1-\frac{1-\alpha}{\alpha}} \eta}{[1 - (1-\delta)\mu](1-\alpha)\delta}.$$

(3.15) needs to be compared to (3.9) to see whether a deviation is profitable. The following Lemma can be established by noting that as $\eta \rightarrow \infty$, (3.9) tends to $(1-\beta)\alpha [(1-\alpha)A]^{1/\alpha}$ whereas (3.15) tends to $(1-\beta)\alpha [(1-\alpha)A]^{1/\alpha} - B(\phi)$, where the term $B(\phi)$ is an increasing function of ϕ and is always strictly positive. In particular, in the limit of $\eta \rightarrow \infty$, we have $B(\phi) \rightarrow \frac{(1-\delta)\beta[A(1-\alpha)]^{1/\alpha}}{(1-\alpha)\delta} > 0$. Thus (details in the appendix):

Lemma 3. *There exists $\eta^*(\phi) > \bar{\eta}$ such that for $\eta < \eta^*(\phi)$, a separating equilibrium does not exist. And for $\eta \geq \eta^*(\phi)$, there exists a separating equilibrium in which a proportion μ of firms choose k_1 and a proportion $(1-\mu)$ choose k_2 where k_1, k_2 , and μ are given by (3.7) and (3.12).*

The presence of pooling and separating equilibria for certain values of the parameters η and ϕ has now been established. Figure 1 draws the key parameter space for this economy. In the northwest corner, Region I, there is only a unique pooling steady state equilibrium; in the southeast corner, Region III, we have a unique separating steady state equilibrium; and in the northeast corner, Region II, both a separating and pooling steady state equilibria exist. The intuition for this multiplicity is that for high values of ϕ and η , when we are in a pooling equilibrium, there is no profitable deviation since ϕ is high and a deviant firm aiming to recruit only the skilled has a small probability of meeting the right worker. However, when we are in a separating equilibrium firms do not want to pool across the two types because the outside option of the high skill workers will bind and firms will be forced to pay them high wages even when they choose the pooling capital stock. Hence, the force that maintains a multiplicity of equilibria is the impact of different compositions of jobs in the two steady state equilibria on the *outside option of skilled workers*. Finally, to see that Region II, the area where the exist multiple equilibria, is non-empty, it suffices to note that as $\phi \rightarrow 1$, all values of η are consistent with a pooling equilibrium whereas even as $\phi \rightarrow 1$, high values of η are also consistent with a separating equilibrium as $\mu \rightarrow \max \left\{ \frac{1-(1-\delta)\eta}{(1-\delta)}, 0 \right\}$ and $B(\phi) > 0$.

3.5. The Mixed Equilibrium

In the southwest corner of Figure 1 there exists neither a pooling nor a separating equilibrium. If all firms are accepting both types of worker, a firm can increase its profits by deviating and only accepting skilled workers. On the other hand, if there is a separating allocation, there again exists a profitable deviation with one firm choosing a middling job and accepting all workers. Instead, there exists a mixed equilibrium where some firms accept both types of workers while others employ only the skilled. A mixed equilibrium has the following features: (1) $\exists \rho \geq 0$ such that $k_i = k_p \forall i \leq \rho$ and $k_i = \bar{k} \forall i > \rho$; (2) $Ak_p^{1-\alpha} - k_p \geq \bar{w}^u$ and $Ak_p^{1-\alpha}\eta^\alpha - k_p \geq \bar{w}^s$; and (3) $A\bar{k}^{1-\alpha}\eta^\alpha - \bar{k} \geq \bar{w}^s$ and $A\bar{k}^{1-\alpha} - \bar{k} < \bar{w}^u$.

In this equilibrium, the profit of the pooling firms can be written as:

$$\Pi_p(k_p) = \frac{(1-\delta)}{\delta} \left[(1-\lambda) \min \left\{ (1-\beta) \left(Ak_p^{1-\alpha}\eta^\alpha - k_p \right); Ak_p^{1-\alpha}\eta^\alpha - k_p - \bar{w}^s \right\} + \lambda(1-\beta) \left(Ak_p^{1-\alpha} - k_p \right) \right] \quad (3.16)$$

The profit level of separating firms will be:

$$\hat{\Pi} = \frac{(1-\lambda)(1-\beta)(1-\delta)\alpha [(1-\alpha)A]^{1/\alpha} \eta}{(1-\alpha)\delta}. \quad (3.17)$$

Equilibrium is then given by (details in the appendix):

$$\hat{\Pi} = \max_{k_p} \Pi_p(k_p). \quad (3.18)$$

The number unskilled workers who are unemployed will be given as:

$$\phi\delta = (\delta + (1-\delta)\rho) U^U.$$

where ρ is the proportion of firms that do not accept low skill workers. Therefore,

$$\lambda = \frac{\phi}{\phi + (1-\phi)(\delta + (1-\delta)\rho)}. \quad (3.19)$$

The mixing equilibrium exhibits lower wage inequality and lower unemployment than the separating equilibrium but more than the pooling equilibrium.

Lemma 4. *In the region where $\eta < \eta^*(\phi)$ and $\eta^\alpha > \frac{\phi}{(1-\phi)^\alpha - (1-\phi)}$, there exists a mixed equilibrium characterized by (3.18) and (3.19).*

3.6. Summary of the Results

In this section the results for the steady state equilibrium are summarized in the form of a proposition [see also Figure 1]. The proof follows the lemmas and is thus omitted.

Proposition 1. *There exists $\eta^*(\phi)$ such that*

1. *If $\eta > \eta^*(\phi)$ and $\eta^\alpha > \frac{\phi}{(1-\phi)^\alpha - (1-\phi)}$, then there exists a unique separating equilibrium and no pooling equilibrium.*
2. *If $\eta < \eta^*(\phi)$ and $\eta^\alpha < \frac{\phi}{(1-\phi)^\alpha - (1-\phi)}$, then there exists a unique pooling equilibrium and no separating equilibrium.*
3. *If $\eta > \eta^*(\phi)$ and $\eta^\alpha < \frac{\phi}{(1-\phi)^\alpha - (1-\phi)}$, then there exists a multiplicity of equilibria, both the separating and the pooling steady states co-exist.*
4. *If $\eta < \eta^*(\phi)$ and $\eta^\alpha > \frac{\phi}{(1-\phi)^\alpha - (1-\phi)}$, then there exists neither a separating nor a pooling equilibrium, and there is instead a mixed equilibrium where some firms accept both types of workers and others specialize.*

3.7. Comparative Statics

In this section I analyze the response of the search equilibrium to a change in the underlying parameters η and ϕ . According to the conventional wisdom, the past twenty years have been characterized by skill-biased technological change, making the skilled even more productive relative to the unskilled. This can be captured in this setting as an increase in η .¹⁰ Another important development of the past twenty years is the rapid change in the composition of the workforce. With the baby-boom generation arriving in the market with high educational attainments, and college enrollments increasing substantially during the Vietnam War, the average skill level of the workforce has improved considerably, and this can be captured as a fall in ϕ .

¹⁰Another candidate for the increased wage inequality is globalization and competition from unskilled labor abundant economies which may reduce the prices of unskilled labor intensive goods. This can also be captured in the model as an increase in η . For instance, we can imagine skilled workers producing a different good than unskilled workers and an increase η would be equivalent to a change in relative prices. I thank Jaume Ventura for suggesting this interpretation.

3.7.1. A Change in η

First, note that an increase in η will always increase the skilled wages and thus lead to increased wage inequality. This is the conventional story. Yet, in this model a change in η has two distinct effects: (1) a change in wages within an equilibrium; (2) switch from one type of equilibrium to another. For instance, suppose that we are in Region I (with a unique pooling equilibrium) and η increases. Wage inequality will increase only by a small amount [a 1% increase in η will increase wage inequality by $\alpha\%$ since both skilled and unskilled workers are employed in the same firms]. Moreover, as shown in Acemoglu (1995a), in this environment (as opposed to a Walrasian setting) the increase in η will actually make unskilled workers *better off* because the physical capital investments of firms, k_p , are increasing in η , and in this region, unskilled wages are increasing in k_p . Next consider an increase in η in Region III where there is a unique separating equilibrium. Again wage inequality increases but unskilled wages are unchanged because the firms employing unskilled workers do not reduce their physical capital investment [a 1% increase in η will increase wage inequality by 1%]. Moreover, now unskilled workers are *hurt* by the increase in η ; although unskilled wages are unchanged, the increase in η reduces the proportion of low physical capital vacancies and thus unskilled unemployment increases.

However, the most powerful change comes when we cross from one region to another. This is a feature of the non-convexity introduced by search costs. Note that as η increases we move to the right in Figure 1, which means that we can switch from Region I into Region II or from Region IV into Region III. As we switch from Region I into II, the unique pooling equilibrium is replaced by a multiplicity of equilibria, thus the nature of equilibrium changes. If a pooling equilibrium is replaced by a separating equilibrium, there will be a *drop* in unskilled wages, an increase in skilled wages and in the unemployment of both the skilled and the unskilled. Recall that this type of result could never be obtained in the frictionless competitive benchmark; there a 1% increase in η leads to 1% increase in the wage gap, but not to a drop in unskilled wages. Alternatively, we could switch from Region IV into Region III in which case a mixing equilibrium is replaced by a separating equilibrium and similar results are obtained (but the change in wage inequality and unemployment will be less pronounced).

3.7.2. A Change in ϕ

The other interesting change for the purposes of this paper is a decrease in ϕ , an improvement in the quality of the labor force through more rapid entry of skilled workers. Again the impact of this change will depend on which region we are in. Let us assume that we start in Region I (Northeast) and ϕ decrease. First, as long as the economy stays in this Region, unskilled wages increase together with skilled wages. However, as ϕ falls further, we reach the boundary of Region I. We now move into a mixing or a purely separating equilibrium and in both cases, the qualitative results are similar. If we move into a mixing equilibrium, unskilled wages fall, skilled wages increase, unskilled unemployment increases and skilled unemployment remains constant. If we move into the separating equilibrium region, skilled unemployment also increases. To summarize these changes Figure 2 draws the steady state unskilled wages and unskilled unemployment as a function of $1 - \phi$. The impact is very different compared to the frictionless benchmark of section 2.2. In the competitive equilibrium a change in ϕ never altered the effective demand for skilled workers, thus the wage gap between the two groups was independent of ϕ . In contrast, due to the non-convexity caused by labor market frictions, in the search equilibrium the demand for skill *overshoots* the increase in the proportion of skilled workers and thus causes a collapse of the demand for the unskilled.

3.7.3. The Aftermath of a Change in η

I have so far treated the composition of the labor force, ϕ , as an exogenous variable. This is motivated by two considerations. First, this is the simplest way of highlighting the different predictions of this model: in the standard models ϕ either has no effect, or everything else being equal reduces wage inequality, whereas in my model it can increase wage inequality and unemployment. Second, a substantial part of the change in the composition of the labor market of the U.S. during the 70s may in fact be exogenous (e.g. the baby-boomers and the Vietnam GI Bill). However, ultimately ϕ should be endogenous. As an illustration consider the following scenario: each worker has a cost γ to become skilled and as soon as he is born, he has to decide whether to do so. If we assume that γ has a distribution across workers given by $G(\gamma)$, then clearly in a steady state equilibrium we would have $\phi = 1 - G(V^s - V^u)$ where V^s is the present discounted value of a skilled worker and V^u is the present discounted value of an unskilled worker upon

birth. The analysis so far has shown that a small change in η can have a large impact on wage and unemployment inequality, thus on the difference $V^s - V^u$, but with the composition of the labor force endogenized, ϕ would fall further, strengthening the initial impact of the change in η .

Therefore, overall the model can account for the changing composition of the labor force in terms of a small change in the relative productivity of different groups, and/or explain the changing technology due to the changes in the composition of the labor force.

4. Social Surplus in Different Steady State Equilibria

This section characterizes the allocation a social planner would choose in order to maximize the sum of all utilities (thus no distributional concerns) subject to the same matching imperfections. Therefore, the planner chooses physical capital investments and an acceptance rule for vacant firms and unemployed workers. I restrict attention to the comparison of the pooling and separating steady states.

4.1. Comparison of Pooling and Separating Steady States

With a similar reasoning to before, the social planner would choose two capital levels:

$$\hat{k}_1 = (A(1 - \alpha))^{1/\alpha},$$

$$\hat{k}_2 = (A(1 - \alpha))^{1/\alpha} \eta.$$

The social surplus in the separating steady state can be obtained as the sum of the surplus from skilled and unskilled jobs every period. Thus,

$$S_S = \hat{\mu} \hat{U}^u (A(1 - \alpha))^{1/\alpha} + (1 - \hat{\mu}) \hat{U}^s (A(1 - \alpha))^{1/\alpha} \eta, \quad (4.1)$$

where $\hat{\mu}$ is the proportion of unskilled vacancies chosen by the planner and \hat{u} 's denotes the steady state unemployment levels in the planner's allocation. The planner maximizes (4.1) by choosing $\hat{\mu}$, but she must take into account that \hat{U}^u and \hat{U}^s are also endogenous. With a similar accounting exercise as before:

$$\begin{aligned}\hat{U}^u &= \frac{\phi\delta}{[\delta + \hat{\mu}(1 - \delta)]} \\ \hat{U}^s &= \frac{(1 - \phi)\delta}{[\delta + (1 - \hat{\mu})(1 - \delta)]}\end{aligned}\tag{4.2}$$

In contrast, if the planner decides a pooling allocation, social surplus is equal to:

$$S_P = \delta ([\phi + (1 - \phi)\eta^\alpha]A(1 - \alpha))^{1/\alpha}\tag{4.3}$$

Comparing (4.1) and (4.3), the following result can be established:

Proposition 2. (i) Suppose (3.6) holds, then the pooling steady state always has higher social surplus.

(ii) Suppose (3.6) does not hold. Then there exists $0 < \hat{\delta}(\eta) < 1$ such that for an economy with relative skills parameterized by η , if $\delta < \hat{\delta}(\eta)$ then the constrained efficient steady state allocation is separating and if $\delta > \hat{\delta}(\eta)$, then the constrained efficient steady state allocation is pooling.

This proposition shows that the separating and pooling allocations cannot be unambiguously ranked in terms of welfare; the ranking depends on how heavily the future is ‘discounted’ (δ) and on the productivity differentials (η). However, since (3.6) is also the condition for the pooling equilibrium to exist, whenever the pooling equilibrium exists it has higher social surplus than a separating allocation. When (3.6) does not hold a pooling equilibrium does not exist, but a pooling allocation may still have higher surplus. In this case, if $\delta = 0$ the separating allocation is preferred because the cost of slow job creation disappears and the only concern is allocating workers to jobs in which their productivity is highest, and the separating equilibrium achieves this. On the other hand, as $\delta \rightarrow 1$, because the cost of slow job creation is very high, a pooling allocation is preferred even if the unique decentralized equilibrium is a separating one. The evidence in Barron et al (1985) and Levy and Murnane (1995) regarding the costs incurred by firms in the recruitment process and the evidence in Ruhm (1991) and Topel and Ward (1992) regarding the costs that workers incur in changing and finding jobs suggests that δ is in general away from zero, thus the analysis here not only shows that the increase in the demand for skills is endogenous (in response to deeper changes in the economy), but it may also be associated with more serious distortions in

the allocation of resources. A different way of expressing the intuition is that the rents for unskilled are substantially reduced when the economy switches to a separating equilibrium, and since these rents do not feature in firms' calculations, the switch creates negative externalities on unskilled workers.

Finally, note that even if $\delta < \hat{\delta}(\eta)$, a switch from the pooling to the separating equilibrium need not increase social surplus. This is because Proposition 2 is stated for the optimal value of $\hat{\mu}$ whereas in the separating equilibrium μ is determined by the zero-profit condition. Thus, although the social surplus of the pooling steady state would be given by S_P , the social surplus of the separating steady state equilibrium will be in general less than S_S .

4.2. Counterproductive Policies

To conclude this section, I want to note that two policies which may appear rather effective in dealing with the inefficiency of a separating equilibrium may in fact have counter-productive consequences in this setting.

First, it may be thought that since the increase in inequality is closely related to the inefficiency of the separating equilibrium, increasing low-skill wages is beneficial. However, it is easy to see that if a minimum wage at some level, $w_M > w_1$ is introduced, unemployment will increase without affecting skilled wages¹¹ and moreover this policy would reduce the creation of 'unskilled' jobs.

Second, since the wages and labor market outcomes of unskilled workers have deteriorated, it may be good policy to offer training to unskilled workers. Yet, this policy will also have a number of undesired effects. In particular, a decrease in ϕ will, in this model, worsen the fortunes of the remaining unskilled workers.

¹¹For instance, suppose that European economies have institutional barriers that prevent unskilled wages from falling (e.g. unionization and minimum wages), then we would expect a higher unskilled unemployment and lower wage inequality in Europe. However, wages at the top of the distribution would not be affected by these restrictions, and it is interesting to note that Blau and Khan (1994) find that U.S. wage inequality is very similar to those of other countries when the workers at the ninetieth percentile are compared to the median, but much more unequal when the lowest paid are compared to the median. However, note that minimum wages are not always ineffective in this class of models because they may influence the composition of jobs (see Acemoglu, 1996).

5. A More General Matching Technology

The analysis has so far assumed that firms and workers meet randomly. However, in the real world a firm opening a vacancy for a skilled worker does not have an equal chance of attracting a skilled and unskilled worker. Instead, skilled workers are more likely to apply, though in the absence of the Walrasian auctioneer, there is no guarantee that only the right workers would apply; some over and under-qualified workers will also be attracted [see Sicherman, 1991's evidence on over and under-education in the workplace, see the discussion in section 6]. It is a shortcoming of most search models that they mainly rely on the random matching technology because other matching technologies make the models excessively complicated.

This section extends the analysis to a more general technology. I assume that in each period firms and workers can be on two different islands, A and B and ex ante they do not know on which island they will be. As a result, in every period a random proportion q of the workers and firms looking for a match will be on Island A and the remaining $1 - q$ proportion will be on Island B. Agents on Island A will be matched *efficiently* and the agents of Island B will be matched randomly. Efficient matching implies that high physical capital firms are allocated to the skilled workers and vice versa. In other words, the efficient matching technology mimics the allocation of a Walrasian auctioneer. Formally, let us construct ranks for both groups such that the rank of agent j^* in group F is $\Omega_F(j^*) = \int_{j \geq k(j^*)} dj$ and similarly, the rank of a worker i^* is $\Omega_W(i^*) = \int_{i \geq h(i^*)} di$. If matching between a group of firms F and a group of workers W is efficient, then a firm and a worker are matched together only if they have the same ranks in their respective orders.¹² As a result, the hybrid matching technology here implies that with a probability $1 - q$, a firm is allocated to a worker randomly drawn from the distribution of workers and with probability q it is allocated to the worker that the Walrasian auctioneer would have chosen. As a real world justification, consider the situation

¹²This definition is a version of that given in Acemoglu (1995b) which was for an environment in which the distribution of workers has connected and continuous density and therefore it did not fully specify some details that arise with atoms in the distribution of workers. In particular, suppose there are two groups of firms, one allocated to the skilled workers and the other to the unskilled. Now one of the high capital firms deviates and reduces its investment by ϵ , will it still get allocated to a skilled worker? Here, our matching technology is such that the answer is no. Had the answer been yes, there would be a problem of non-existence of equilibrium [details available from the author upon request].

in which workers look at the available vacancies and apply to the firm with which they want to work. However, with probability $1 - q$ workers make a mistake in their assessment and as a result apply to a random firm. Alternatively, it can be assumed that workers use multiple job search methods, and some put them in contact with the most suited firm while others lead to a match a random firm. In this section, it will be shown that for all $q < 1$, the previous qualitative results hold. Thus, the qualitative results of this paper require neither extreme randomness in matching nor highly inefficient institutions.

5.1. The Separating Allocation

A separating allocation is one in which there are two types of firms and each type *turns down* one type of worker.

Lemma 5. *Suppose the proportion of unskilled workers in the unemployment pool is λ . Then, exactly a proportion λ of vacancies choose k_1 and a proportion $1 - \lambda$ choose $k_2 > k_1$, that is $\mu = \lambda$.*

The proof of this lemma is in the appendix. The intuition is straightforward. Suppose the proportion of low capital firms is $\mu > \lambda$. There will be a positive probability that a firm with k_2 selected for efficient matching will not be allocated to a skilled worker because there are more firms with k_2 than skilled workers in the efficient allocation pool. A firm can increase its investment to $k_2 + \epsilon$ and guarantee to meet a skilled worker and for ϵ small enough this would be profitable. A similar reasoning for $\mu < \lambda$ establishes $\mu = \lambda$.

Given $\mu = \lambda$, the profit levels are:

$$\begin{aligned}\Pi_1(k_1) &= \frac{(1 - \delta)[q + (1 - q)\lambda](1 - \beta) [Ak_1^{1-\alpha} - k_1]}{\delta}, \\ \Pi_2(k_2) &= \frac{(1 - \delta)[q + (1 - q)(1 - \lambda)](1 - \beta) [Ak_2^{1-\alpha}\eta^\alpha - k_2]}{\delta}.\end{aligned}\tag{5.1}$$

Intuitively, a firm gets selected for efficient matching with probability q and in this case, $\mu = \lambda$ implies that with probability 1 it is matched with a worker it would accept. With probability $(1 - q)$, it is a random match and it can meet a worker it will not employ (which has probability $1 - \lambda$).

From a slight modification of the accounting equations used before, unemployment numbers for the skilled and the unskilled can be written as:

$$\begin{aligned} U^u &= \frac{\phi\delta}{[\delta + (q + \lambda(1 - q))(1 - \delta)]}, \\ U^s &= \frac{(1 - \phi)\delta}{[\delta + (q + (1 - \lambda)(1 - q))(1 - \delta)]}, \end{aligned} \quad (5.2)$$

where $\mu = \lambda$ has been used. Noting that $\frac{u^u}{u^s} = \frac{\lambda}{1 - \lambda}$, this equation solves for an equilibrium value of $\bar{\lambda}(q)$. Next, we need to make sure that at the given composition of the unemployment pool, both types of firms make the same amount of profits. However, this is not possible if both groups were to choose their capital stocks to maximize (5.1) because high capital firms would make higher profits (as they are meeting with higher human capital firms most of the time). This implies that no firm would want to choose k_1 [see Figure 3]. However, a firm can do better by choosing $k_2 + \epsilon$ rather than k_2 because in this case there will be more k_2 firms than skilled workers and having more physical capital will guarantee a skilled worker. This reasoning implies that firms will ‘race’/overinvest in order to match with the skilled workers. However, there is a limit to how much ‘overinvestment’ there will be because a firm can always switch to k_1 and earn the profits of a low physical capital firm. This reasoning gives the two equilibrium conditions (5.3) and (5.4):

$$k_1 = ((1 - \alpha)A)^{1/\alpha}, \quad (5.3)$$

and k_2 is chosen such that

$$\Pi_2(k_2) = \frac{\alpha(1 - \delta)[q + (1 - q)\lambda](1 - \beta)((1 - \alpha)A)^{1/\alpha}}{\delta(1 - \alpha)}, \quad (5.4)$$

where $\Pi_2(\cdot)$ is given by (5.1). The determination of k_1 and k_2 is given diagrammatically in Figure 3.

To see whether this allocation is an equilibrium, suppose a firm chooses k_d and accepts all workers. When this firm is on Island A (i.e. selected for efficient allocation) and there are $1 - \lambda$ firms that have chosen k_2 , it will get allocated to an unskilled worker. On the other hand, if it is selected for random matching, it

will match with a skilled worker with probability $1 - \lambda$ and in this case, as before, it has to pay the outside option of this worker \bar{w} . Then its profits are given as

$$\Pi_d = \frac{(1 - \delta)}{\delta} \left[(q + (1 - q)\lambda)(1 - \beta)(Ak_d^{1-\alpha} - k_d) + (1 - q)(1 - \lambda)(Ak_d^{1-\alpha}\eta^\alpha - \bar{w}^s) \right] \quad (5.5)$$

where \bar{w}^s is now given by

$$\bar{w}^s = \frac{(q + (1 - q)(1 - \bar{\lambda}))(1 - \delta)\beta(Ak_2^{1-\alpha}\eta^\alpha - k_2)}{1 + (1 - \delta)((1 - q)\bar{\lambda})}. \quad (5.6)$$

An argument similar to the one used before establishes [proof omitted]:

Proposition 3. *There exists $\eta(q, \phi)$ such that if $\eta \geq \eta(q, \phi)$, then a separating equilibrium exists in which $\mu = \lambda$ and k_1 and k_2 are determined by (5.3), and (5.4).*

5.2. The Pooling Allocation

In the pooling allocation all firms *accept both types of workers*. It may thus be tempting to think that, as in the equilibrium of section 3, there will only be one type of firm choosing physical capital k_p . However this is incorrect. The next Lemma states this result (proof in the appendix).

Lemma 6. *With $q > 0$, and with the pooling allocation, there will be a proportion $\mu = \phi$ of the vacancies that choose k_{p1} and a proportion $1 - \mu$ that choose $k_{p2} > k_{p1}$.*

To see the intuition, consider the case in which all firms choose the same level of physical capital k_p . There is a probability $q > 0$ that a firm will be selected for efficient matching, and in this case it still has a probability λ of matching with an unskilled worker. By increasing its investment to $k_p + \epsilon$, the firm can ensure that it meets with a skilled worker and makes greater profits. This implies that a symmetric pooling equilibrium does not exist and therefore, even when all firms accept all workers, there will be different physical capital levels [this can be thought as mixed strategies or as a non-symmetric equilibrium]. Applying the reasoning of the previous lemma establishes that two groups of firms with

different physical capital levels have to exist: proportion λ of them with low physical capital and a proportion $1 - \lambda$ of them with high physical capital, and both groups have to make the same level of profits. Moreover, since this is a pooling allocation in the sense that all workers are accepted immediately, it must be the case that $\mu = \lambda = \phi$.

The profit functions for the two types of firms are:

$$\begin{aligned}\Pi_{p1}(k_{p1}) &= \frac{(1 - \delta)(1 - \beta) \left[(q + (1 - q)\phi + (1 - q)(1 - \phi)\eta^\alpha) Ak_{p1}^{1-\alpha} - k_{p1} \right]}{\delta}, \\ \Pi_{p2}(k_{p2}) &= \frac{(1 - \delta)(1 - \beta) \left[(q\eta^\alpha + (1 - q)\phi + (1 - q)(1 - \phi)\eta^\alpha) Ak_{p2}^{1-\alpha} - k_{p2} \right]}{\delta}.\end{aligned}\tag{5.7}$$

Therefore the only difference between the low physical capital (k_{p1}) and high physical capital firms (k_{p2}) is that when allocated to efficient matching (probability q), the latter get matched with skilled workers.

Equilibrium has to satisfy $\Pi_{p1} = \Pi_{p2}$, thus using a similar reasoning to that of Figure 3:

$$k_{p1} = [(q + (1 - q)\phi + (1 - q)(1 - \phi)\eta^\alpha) A(1 - \alpha)]^{1/\alpha}, \tag{5.8}$$

and k_{p2} as in the previous subsection is determined from the equal profit condition as:

$$\Pi_{p2}(k_{p2}) = \frac{\alpha(1 - \delta)(1 - \beta) [(q + (1 - q)\phi + (1 - q)(1 - \phi)\eta^\alpha) A(1 - \alpha)]^{1/\alpha}}{\delta(1 - \alpha)}.\tag{5.9}$$

where Π_{p2} is given by (5.7). Now a deviation from the pooling allocation will be similar to before: a firm can choose a level of physical capital, $\bar{k} > k_2$, and only accept skilled workers. The profit of this firm will be given as

$$\bar{\Pi}(\bar{k}) = \frac{(1 - \delta)(1 - \beta) [q + (1 - q)(1 - \phi)] [A\bar{k}^{1-\alpha}\eta^\alpha - \bar{k}]}{\delta},$$

which gives the optimal investment and profit of the deviant as

$$\tilde{k} = [(q + (1 - q)(1 - \phi)) A(1 - \alpha)]^{1/\alpha} \eta$$

$$\tilde{\Pi} = \frac{\alpha(1 - \delta)(1 - \beta) [(q + (1 - q)(1 - \phi)) A(1 - \alpha)]^{1/\alpha} \eta}{(1 - \alpha)\delta}.$$

A pooling allocation will be an equilibrium only when $\Pi_{p1} \geq \tilde{\Pi}$, thus:

Proposition 4. *If $q + (1 - q)\phi > q\eta + (1 - q)(1 - \phi) [\eta - \eta^\alpha]$, then there exists a pooling equilibrium in which a proportion ϕ of vacancies choose k_{p1} as given (5.8) and k_{p2} as (5.9). In this allocation, all matches are turned into employment.*

Therefore, overall, with the more general matching technology, the qualitative results are unchanged. In particular, there again exist two types of equilibria; in the pooling one unemployment is low and wages are compressed, and in the separating one there is more unemployment and high wage inequality. An increase in q , the degree of efficiency of the matching technology, reduces the set of parameter values for which a pooling equilibrium exists. In this more general model too, an increase in η or a reduction ϕ can lead to a switch from the separating to a pooling equilibrium and to increased wage inequality and unemployment.

6. An Empirical Implication and Some Evidence

As noted earlier, the existing explanations for the rise in wage inequality and increased unskilled unemployment have no immediate implications about the level of unskilled wages, they predict that skilled unemployment should fall (since demand for skilled workers has increased) and also, the rise in the proportion of workers with higher educational attainments should be a factor that counteracts the rise in inequality. In contrast, the theory I offer suggests that the increase in the proportion of skilled workers in the labor force (see footnote 3) can be a driving force or at least a contributing factor for these trends, that unskilled wages should fall in absolute levels and that unemployment rates should increase for the skilled workers as well as the unskilled (see footnote 2). Therefore, this theory matches the general patterns that we observe much better than the existing theories. Nevertheless, it may be possible to extend existing theories to match most

of these facts. For instance, an aggregate shock that increases unemployment for both groups may have coincided with a relative demand shock. It is the purpose of this section to draw a more micro-level prediction of this paper's approach that is not shared by the existing theories.

6.1. An Empirical Implication

My theory suggests that skilled and unskilled workers were doing similar jobs in the 70s, but in the 80s there was a change in the structure of jobs such that the quality of the jobs for the skilled improved and those for the unskilled deteriorated. PSID 1976, 1978 and 1985 ask the participants how many years of schooling their jobs require. In principle, it is difficult to determine exactly how this question is interpreted by the respondents, and moreover, the model here is not only about schooling but also about a wide variety of skills (many of which are unobservable to the econometrician). Nevertheless, the careful work by Sicherman (1991) using the 1976 and 1978 waves of PSID shows that there is a lot of interesting information transmitted by this question. Sicherman finds that overeducated workers (those with more education than the reported amount) earn more than other workers doing the same job and less than similar workers with the same amount of education. The finding is reversed for undereducated workers. Also, it is important to emphasize that these findings do not reflect just unobserved heterogeneity - overeducated workers having less unobserved 'capital'- because Sicherman shows that overeducated workers appear to have a significantly higher probability of getting promoted or moving to a higher paying job.

In my theoretical model, when there is only one type of job (*pooling equilibrium*), skilled workers are 'overeducated' for their jobs since they are working at a lower physical to human capital ratio than the competitive equilibrium [see section 2.2] while the unskilled would be undereducated. In contrast, in *separating equilibrium* this source of over and undereducation would disappear. Therefore, my theory predicts that in the 1985 wave the amount of over and undereducation should be lower compared to 1976 and 1978, or in other words, from 1976 to 1985, average match quality should have improved. This is irrespective of whether the driving force is a change in ϕ (composition of labor) or a change in η (technological shock). In either case, mismatch should go down. This prediction is not shared by any other theory that I am aware of, therefore it constitutes a good test of the theory offered in this paper.

6.2. Some Evidence

To test this prediction I construct the difference between actual education and the reported required years of schooling for 1976, 1978 and 1985 for male heads of households between 18-60, who are currently in employment but are not self-employed.¹³ I first summarize the data in Table 1. Individuals who report required education in a higher bracket than their actual education are *undereducated*, those who report the same bracket are *exact* and those who report a lower required education bracket than their actual education are *overeducated*. The first three columns report the number of individuals in each year in the corresponding groups, the second three columns report the average number of years of overeducation (actual minus required) for individuals in each category.

Table 1 - Overeducation Numbers

	No. of Obs			Average Overeducation		
	1976	1978	1985	1976	1978	1985
Overeducated	978	1028	1149	4.78 (2.81)	4.83 (2.82)	3.50 (3.13)
Exact	1045	1174	1350	-0.04 (0.41)	-0.02 (0.37)	0.00 (0.27)
Undereducated	424	517	438	-2.42 (1.63)	-2.53 (1.71)	-2.71 (1.51)
Total	2447	2719	2937	1.47 (3.40)	1.35 (3.42)	0.966 (3.02)

Note: standard deviations in parentheses in the last three columns.

The first way of seeing the changes from 1976 to 1985 is to look at the number of workers who are overeducated and undereducated and the mean of over and undereducation. The numbers in Table 1 show that from 1976 to 1978, there has been a mild increase in the number of individuals who report to have the required

¹³All data are from the PSID. The reported required years of schooling is a bracketed variable which takes the values 0-5, 6-8, 9-11, 12, 13-15, 16, 17 [the exact question was "how much formal education is required to get a job like yours?"]. The actual schooling variable is last grade completed. Because in 1985, actual schooling was only available in the individual files, for consistency, the education variable from the individual files has been used for 1976 and 78 as well. Using the education variable from the family files for 76 and 78 does not change any of the results for these years. In all the calculations, the following values were substituted for the required education variable: 4 when the bracket was 0-5, 8 for the bracket 6-8, 10 when the bracket was 9-11 and 14 when the bracket was 13-15. These are the values used by Sicherman (1991) and using the means of the relevant brackets (e.g. 2.5 instead of 4) increases the magnitude of the changes from 1976 to 1985.

education for their jobs relative to those who are either under or overeducated, and there was a large increase from 1978 to 1985. More precisely, the proportion of workers who have the required years of schooling for their jobs has increased from 42% in 1976 to 43% in 1978 and to 46% in 1985 [the increase from 1976 to 85 is significant at 1%]. Moreover, the average number of years of schooling that an overeducated worker has beyond what is required for his job and the average number of years of schooling that an undereducated worker has less than what is required have declined from 1976 to 1985, again suggesting that the workers are better matched to their jobs in 1985 than before. The changes from 1976 to 78 are insignificant at the 10% level whereas all the changes from either 1976 or 1978 to 85 are always significant at 1%. Therefore, the main prediction of the theory appears to be supported by these trends.

To give some more information about these workers, Table 2 reports additional information. In particular, it gives average years of schooling, average age, average tenure with the firm at the time of the survey (in months), and average required training on the job (in months) for the workers of different groups.¹⁴

Table 2 reveals that overeducated workers tend to have lower tenure, and are younger, but this pattern is unchanged across the years, thus the better matching is not explained by changes in these aspects. Also, undereducated workers tend to be less educated than those who report to be overeducated and those who have the required years of education (Exact), whereas the latter two groups have on average similar levels of actual education. Finally, the amount of required training is higher for undereducated workers which suggests that what these workers lack in terms of schooling is being made up by additional training relative to the other groups of workers. Again these aspects are unchanged between 1976 and 1985, thus appear to be unrelated to the cause of the decreased dispersion of overeducation across workers.

¹⁴Note that different columns have different sample sizes in Table 2 depending on the response rate for the relevant question. The tenure numbers for 1978 are considerably lower than for other years, and I have no explanation for this finding, but the sample size is extremely low for this question in 1978. Required training is the answer to the question: "On a job like yours how long would it take an average person to be fully trained and qualified?"

**Table 2 - Worker Characteristics
by Overeducation Category**

	Average Schooling	Average Age	Average Tenure	Av. Req. Training
Overeducated 76	11.89	33.09	69.39	14.10
Exact 76	12.24	34.75	91.33	20.14
Undereducated 76	11.53	39.56	126.58	25.54
Overeducated 78	12.12	33.82	41.57	20.12
Exact 78	12.36	34.59	54.02	31.03
Undereducated 78	11.40	39.49	58.49	39.98
Overeducated 85	13.35	33.79	80.55	17.53
Exact 85	13.24	34.51	94.07	19.23
Undereducated 85	11.08	40.23	135.01	21.03

A different and perhaps more transparent way of seeing the trend is to calculate the variation of 'mis-education'/'mismatch' across workers in each year. This is done in Table 3 using two alternative methods. The first row reports the cross-sectional variance of mis-education (actual minus required) across individuals in a given year, and the second reports the sum of the absolute value of overeducation divided by the number of workers (that is the average number of years that an individual appears to be over or undereducated within a given year). Both measures show a large decline from 1976 to 1985. For instance, the cross-sectional variance falls from 11.625 in 1976 to 9.177 in 1985 and the average absolute deviation falls from 2.4 to 1.8, in both cases a drop of over 20% in the course of 9 years [and significant at 1%].

Table 3 - Dispersion of 'Mismatch'

	1976	1978	1985
Variance of Overeducation	11.625	11.723	9.177
Av. Absolute Deviation	2.379	2.342	1.821

6.3. Alternative Explanations

The first objection to these results is that the overeducation variable does not contain any interesting information. However, this interpretation is refuted by the

wage regressions in the next subsection, and more importantly, by Sicherman's findings that overeducated workers have a higher likelihood of moving to a better job which suggests that these workers are truly overqualified for their current jobs.

A second possible interpretation of the overeducation variable is that workers at the early stages of their career or tenure may be classified as overeducated. This interpretation is supported by the numbers in Table 2 since overeducated workers have lower tenure and are younger. A particular version of this story would be that firms have specific 'ports-of-entry' and workers are promoted to better jobs after reaching a certain seniority in the firm. In this interpretation, overeducated workers are those who have just joined the firm. However, this unlikely to be the whole story since the age and tenure patterns have not changed from 1976 to 85, and thus if overeducation were only determined by age and tenure, it would be impossible to understand why match quality appears to have improved so much from 1976 to 1985. To investigate the issue of tenure more closely, I restricted the sample to 'new' workers, i.e. those who have had less than three years with their firm. The results for this group is, if anything, stronger; the proportion of workers with exact education has increased from 38% in 1976 to 45% in 1985, the mean of overeducation for overeducated workers has decreased from 4.97 to 3.85, the variance of mis-education across all workers has fallen from 11.96 to 9.82 and the average absolute overeducation has decreased from 2.658 to 1.997. Again these changes are larger than 20% and are all statistically significant at 1%.

The third alternative explanation could be that the sample in 1976 contains workers who obtained their education before the Second World War or had to interrupt their education because of the War. To deal with this problem, I repeated the same calculations with a sample of workers aged 18-45 in all three years and exactly the same pattern of results was obtained, for instance, the variance of mis-education decreased from 11.36 in 1976 to 8.79 in 1985.

A fourth alternative explanation for these findings would be that the variance of actual schooling has decreased across workers in the course of these 9 years and this fall in the variance of actual schooling explains the decline in the variance of overeducation. To deal with this alternative, I calculated the variance of schooling for these years. Unfortunately, the variance of schooling across individuals has actually fallen from 1976 to 1985, thus I cannot reject this alternative explanation. However, it has to be noted that even with this fall in the variance of education I am aware of no other theory that can account for the large decline in the dispersion of overeducation across individuals, and this decline should still be interpreted as

an improvement in the average match quality which is the prediction of the theory offered in this paper. Further, when the sample is restricted to those between the ages of 18-45 or to those who have less than three years of tenure with their firm, the decline in the variance of education is very slight, but as reported in the above paragraphs, the variance of mismatch appears to have decreased by over 20% in both subsamples, therefore this decline in the variance of education is unlikely to be the only cause of improved match quality.

Therefore, overall the evidence from PSID is supportive of the key mechanism suggested in this paper that the increase in inequality is associated with a shift from a pooling type equilibrium to a separating type equilibrium. In fact, no other theory appears to be able to explain a drop in the dispersion of overeducation by over 20% in the course of 9 years.

6.4. Wages and Overeducation

Have the changes in the dispersion of overeducation and average quality of matches contributed to the increased wage inequality? Unfortunately, it is not possible to answer this question. Nevertheless, there are some suggestive signs. Table 4 reports cross-sectional regressions of wages on schooling and a dummy indicating whether the individual is over or undereducated.

Table 4 - Wage Regressions

	1976	1978	1985
Education	0.0631 (22.93)	0.0563 (13.14)	0.099 (26.760)
Overeducated	-0.158 (-8.48)	-0.131 (-6.50)	-0.123 (-6.60)
Undereducated	0.165 (7.23)	0.070 (2.42)	0.254 (9.252)
No. of Obs.	2261	1295	2629
R^2	0.242	0.158	0.225

Note: t-statistics in parentheses. The wage variable is logarithm of hourly nominal wage for workers paid by the hour and salaried workers. Workers paid by other methods such as commission or tips are excluded. The omitted group is Exact.

Three patterns are apparent in Table 4. First, the return to education has increased from 1976 to 1985. Second, as found by Sicherman (1991), overeducated

workers earn less than workers with the same amount of education but who work in jobs that require more schooling and undereducated workers earn more than other workers who have the same schooling but are in the exact category. This implies that the increase in the proportion of workers who have the required education for their jobs from 42% in 1976 to 46% in 1985 may have contributed to the increase in wage inequality. In other words, the numbers in Table 4 imply that a worker loses the earnings equivalent of 2.5 years of schooling for being overeducated and now there are 4% less of overeducated workers. The third pattern that emerges from Table 4 is that the return to getting a job for which the worker is undereducated has mildly decreased (from the earnings equivalent of 2.6 additional years of schooling in 1976 to 2.5 years in 1985), and the loss incurred for being overeducated has decreased from the earnings equivalent of 2.5 years in 1976 to 1.25 years in 1985. Therefore, overall, it is impossible to ascertain what the exact contribution of the changing pattern of over, but undereducation has been to the rise in wage inequality and the results in table 4 only suggest that there may have been some contribution.

7. Conclusion

This paper has offered an alternative theory for the increase in wage inequality and unemployment, the two most salient trends in the U.S. labor market during the past twenty years. In my theory, an increase in the proportion of skilled workers or an increase in the relative productivity of skilled workers changes the structure of jobs. The key innovation of this approach is that the structure of jobs is endogenous and due to the transaction costs introduced by search, small changes in either the composition of jobs or relative productivities can lead to a large reorganization on the demand side of labor. It is particularly worth emphasizing that if the exogenous shock is taken to be the change in the composition of skills, this paper endogenizes the often suggested change in the demand for skilled workers and indicates how this change may have been associated with a deterioration in the allocation of resources. The paper also derived an implication from this alternative approach not shared by any other theory and provided evidence from the PSID that supports this prediction.

8. Appendix

Proof of Lemma 2: (i) When the outside option of the high skill workers does not bind, the profit of the deviant can be written as in expression (3.2) with the only difference that λ replaces ϕ . Also from the equilibrium condition (3.9), we know that $\lambda = \eta/(1 + \eta)$. Thus the profit of the deviant is given as

$$\tilde{\Pi} = \frac{\alpha(1 - \beta)(1 - \delta) \{[\lambda + (1 - \lambda)\eta^\alpha](1 - \alpha)A\}^{1/\alpha}}{(1 - \alpha)\delta}. \quad (8.1)$$

The profit level of the firms in the separating allocation is given as:

$$\Pi_1 = \Pi_2 = \frac{\frac{\eta}{1+\eta}(1 - \delta)(1 - \beta)\alpha [(1 - \alpha)A]^{1/\alpha}}{(1 - \alpha)\delta}. \quad (8.2)$$

Since $\frac{\eta}{1+\eta} + \frac{\eta^\alpha}{1+\eta} > \frac{\eta}{1+\eta}$, (8.1) is unambiguously larger than (8.2), thus a deviation is always profitable.

(ii) \tilde{w} increases with η faster than $\beta(Ak_p^{1-\alpha}\eta^\alpha - k_p)$, hence there exists $\bar{\eta}$ such that above this level, the outside option of the skilled workers will bind. QED.

Proof of Lemma 3:

$$\lim_{\eta \rightarrow \infty} \Pi_2 = \frac{(1 - \delta)(1 - \beta)\alpha [(1 - \alpha)A]^{1/\alpha} \eta}{(1 + \eta)(1 - \alpha)\delta} = \frac{(1 - \delta)(1 - \beta)\alpha [(1 - \alpha)A]^{1/\alpha}}{(1 - \alpha)\delta},$$

whereas

$$\lim_{\eta \rightarrow \infty} \tilde{\Pi} = \frac{\alpha(1 - \delta)}{(1 - \alpha)\delta} \left[\frac{A(1 - \alpha) \left(\frac{\eta^\alpha}{1+\eta} + \frac{(1-\beta)\eta}{1+\eta} \right)}{\frac{\eta(1-\beta)}{1+\eta} + \frac{\eta}{1+\eta}} \right]^{1/\alpha} - \frac{\frac{1}{1+\eta}(1 - \mu)(1 - \delta)\beta A [(1 - \alpha)A]^{1/\alpha} \eta}{(1 + (1 - \delta)\mu)(1 - \alpha)\delta}.$$

Now noting that as $\eta \rightarrow \infty$, $\mu \rightarrow 0$,

$$\lim_{\eta \rightarrow \infty} \tilde{\Pi} = \frac{\alpha(1 - \delta)}{(1 - \alpha)\delta} [A(1 - \alpha)]^{1/\alpha} - \frac{(1 - \delta)\beta A [(1 - \alpha)A]^{1/\alpha}}{(1 - \alpha)\delta} < \lim_{\eta \rightarrow \infty} \Pi_2.$$

This proves that for sufficiently large values of η , a separating equilibrium will exist. Next noting that the second term in $\bar{\Pi}$ is unambiguously increasing in ϕ ¹⁵, it is straightforward to see that the higher is ϕ the higher the cut-off level of η needs to be. QED

Proof of Lemma 4: I will now construct the mixed equilibrium. First suppose that the outside option of skilled workers do not bind, thus $\bar{w}^s < \beta [Ak_p^{1-\alpha}\eta^\alpha - k_p]$. Then, clearly, maximizing (3.16) gives $k_p = [[\lambda + (1 - \lambda)\eta^\alpha](1 - \alpha)A]^{1/\alpha}$, thus:

$$\Pi_p = \frac{\alpha(1 - \beta)(1 - \delta) [[\lambda + (1 - \lambda)\eta^\alpha](1 - \alpha)A]^{1/\alpha}}{(1 - \alpha)\delta}. \quad (8.3)$$

Therefore, the equilibrium condition (3.18) is equivalent to

$$\eta^\alpha = \frac{\lambda}{(1 - \lambda)^\alpha - (1 - \lambda)}. \quad (8.4)$$

We know that (8.4) fails to hold when $\lambda = \phi$. However, (8.4) is also increasing in λ and $\lambda > \phi$ and is increasing in ρ (the proportion of firms targeting the skilled). Then from (3.19) we can choose ρ , to satisfy (8.4). The solution to these equations is a mixed equilibrium if

$$\bar{w}^s \leq \beta \left\{ A [[\lambda + (1 - \lambda)\eta^\alpha](1 - \alpha)A]^{(1-\alpha)/\alpha} \eta^\alpha - [[\lambda + (1 - \lambda)\eta^\alpha](1 - \alpha)A]^{1/\alpha} \right\} \quad (8.5)$$

If (8.5) does not hold, then we can look for an equilibrium in which the outside option of high skilled workers hold. In this case, we know from the analysis in the text that the optimal choice of pooling firms is given by (3.14) and the profit level of these firms is given by (3.15). Then all we need to ensure that

$$\bar{w}^s \geq \beta [A\bar{k}^{1-\alpha}\eta^\alpha - \bar{k}] \quad (8.6)$$

where \bar{k} is given by (3.14). If both (8.5) and (8.6) fail to be satisfied, then this implies (3.16) is maximized at the level of capital exactly such that $\bar{w}^s = \beta [A\hat{k}^{1-\alpha}\eta^\alpha - \hat{k}]$ where \hat{k} is given by $A\hat{k}^{1-\alpha}\eta^\alpha - \hat{k} = \frac{\bar{w}^s}{\beta}$. Now $\Pi_p(\hat{k}) = \hat{\Pi}$ can

¹⁵More explicitly $\frac{d\bar{\Pi}}{d\phi} = \frac{\delta^2(1-\alpha)}{[1-(1-\delta)\mu](1-\alpha)\delta} \frac{d\mu}{d\phi} > 0$.

be solved for λ and then (3.19) can be solved for ρ which will give the mixed equilibrium. QED

Proof of Proposition 2: Consider social surplus in the pooling and the separating steady states divided by the probability of death, δ ($\frac{S_P}{\delta}$ and $\frac{S_S}{\delta}$) and evaluate these as $\delta \rightarrow 0$:

$$\lim_{\delta \rightarrow 0} \frac{S_P}{\delta} = [A(1 - \alpha) [\phi + (1 - \phi)\eta^\alpha]]^{1/\alpha}, \quad (8.7)$$

and

$$\lim_{\delta \rightarrow 0} \frac{S_S}{\delta} = [A(1 - \alpha)]^{1/\alpha} \left[\frac{\hat{\mu}\phi}{\delta + \hat{\mu}(1 - \delta)} + \frac{(1 - \hat{\mu})(1 - \phi)}{\delta + (1 - \hat{\mu})(1 - \delta)} \eta \right]. \quad (8.8)$$

(8.8) is maximized when $\hat{\mu} = 0$ or when $\hat{\mu} = 1$. If (8.8) is maximized at $\hat{\mu} = 1$, then it can never be larger than (8.7) and thus the pooling steady state would be preferred. Thus for the separating steady state to be preferred to the pooling we require $\hat{\mu} = 0$ and thus:

$$\lim_{\delta \rightarrow 0} \frac{S_S}{\delta} = [A(1 - \alpha)]^{1/\alpha} (1 - \phi)\eta.$$

Therefore, the separating allocation is preferred to the pooling one when $\delta \rightarrow 0$ if

$$(1 - \phi)^\alpha \eta^\alpha > \phi + (1 - \phi)\eta^\alpha,$$

or

$$\eta^\alpha > \frac{\phi}{(1 - \phi)^\alpha - (1 - \phi)}.$$

This condition is of course the opposite of (3.6) which determined the area of the parameter space where a pooling allocation could be an equilibrium.

Now take the case in which $\delta \rightarrow 1$, then

$$\lim_{\delta \rightarrow 1} S_P = [A(1 - \alpha) (\phi + (1 - \phi)\eta^\alpha)]^{1/\alpha}, \quad (8.9)$$

and,

$$\lim_{\delta \rightarrow 1} S_S = [A(1 - \alpha)]^{1/\alpha} [\hat{\mu}\phi + (1 - \hat{\mu})(1 - \phi)\eta]. \quad (8.10)$$

It is clear that whatever the value of $\hat{\mu}$, (8.9) is larger than (8.10), thus the pooling allocation is preferred. Thus whenever a pooling allocation exists, it is social surplus maximizing. In the case when a pooling allocation does not exist, it may still be social surplus maximizing but it could also be dominated by the separating for low enough values of δ . QED

Proof of Lemma 5: Suppose $\mu < \lambda$. Then, the profit of a firm choosing $k_2 > k_1$ can be written as:

$$\Pi_2(k_2) = \frac{(1 - \delta)[q \frac{1-\lambda}{1-\mu} + (1 - q)(1 - \lambda)](1 - \beta) [Ak_2^{1-\alpha} \eta^\alpha - k_2]}{\delta}. \quad (8.11)$$

Now, consider a deviation such that a firm increases its capital investment to $k_2 + \epsilon$. Then:

$$\Pi_2(k_2 + \epsilon) = \frac{(1 - \delta)[q + (1 - q)(1 - \lambda)](1 - \beta) [A(k_2 + \epsilon)^{1-\alpha} \eta^\alpha - k_2 - \epsilon]}{\delta}. \quad (8.12)$$

For ϵ small enough, (8.12) is larger than (8.11). Thus $\mu < \lambda$ cannot be an equilibrium.

Now suppose $\mu > \lambda$. Then the profit of a firm choosing $k_1 < k_2$ is given as:

$$\Pi_1(k_1) = \frac{(1 - \delta)[q \frac{\lambda}{\mu} + (1 - q)\lambda](1 - \beta) [Ak_1^{1-\alpha} - k_1]}{\delta}. \quad (8.13)$$

Consider a deviation whereby a firm chooses physical capital $k_1 - \epsilon$, then the profits of this firm are given as:

$$\Pi_1(k_1 - \epsilon) = \frac{(1 - \delta)[q + (1 - q)\lambda](1 - \beta) [A(k_1 - \epsilon)^{1-\alpha} - k_1 + \epsilon]}{\delta} \quad (8.14)$$

For ϵ small enough, (8.14) is larger than (8.13). Thus $\mu > \lambda$ cannot be an equilibrium.

Finally at $\mu = \lambda$, any firm that deviates will reduce the probability that it gets matched with the type of worker that it would form an employment relation. QED

Proof of Proposition 3: $\mu = \lambda$ follows from Lemma 4. The rest of the proposition follows Lemma 3, by noting that as $\eta \rightarrow \infty$, $\Pi_2(k_2)$ in (5.1) tends to a larger number than (5.5). QED

Proof of Lemma 6: Suppose all firms choose k_p , then the profit of a firm is given as:

$$\Pi(k) = \frac{(1 - \delta)(1 - \beta) \left[(\phi + (1 - \phi)\eta^\alpha) A k_p^{1-\alpha} - k \right]}{\delta}. \quad (8.15)$$

In contrast if a firm increases its investment by ϵ , it gets

$$\Pi_p(k_p + \epsilon) = \frac{(1 - \delta)(1 - \beta) \left[(q\eta^\alpha + (1 - q)\phi + (1 - q)(1 - \phi)\eta^\alpha) A (k_p + \epsilon)^{1-\alpha} - k_2 - \epsilon \right]}{\delta}. \quad (8.16)$$

For ϵ small enough, (8.16) is larger than (8.15), thus a symmetric equilibrium cannot exist. QED

Proof of Proposition 4: In the pooling equilibrium:

$$\Pi_{p1}(k_{p1}) = \Pi_{p2}(k_{p2}) = \frac{\alpha(1 - \delta)(1 - \beta) \left[(q + (1 - q)\phi + (1 - q)(1 - \phi)\eta^\alpha) A(1 - \alpha)^{1/\alpha} \right]}{\delta(1 - \alpha)}. \quad (8.17)$$

In contrast a deviant firm makes:

$$\tilde{\Pi} = \frac{\alpha(1 - \delta)(1 - \beta) \left[(q + (1 - q)(1 - \phi)) A(1 - \alpha) \right]^{1/\alpha} \eta}{(1 - \alpha)\delta}. \quad (8.18)$$

The comparison of (8.17) and (8.18) gives the results. QED

References

- [1] Acemoglu, Daron (1995a); "A Microfoundation For Increasing Returns in Human Capital Accumulation" forthcoming *Quarterly Journal of Economics* August, 1996.
- [2] Acemoglu, Daron (1995b); "Matching, Heterogeneity and the Evolution of Income Distribution" MIT Working Paper.
- [3] Acemoglu, Daron (1996); "Good Jobs, Bad Jobs and Unemployment" in progress.
- [4] Barron, J. M., J. Bishop and W. C. Dunkelberg (1985); "Employer Search: The Interviewing and Hiring of New Employees" *Review of Economics and Statistics* Vol 67, pp 43-52.
- [5] Blau, Francine D. and Lawrence M. Khan (1994); "International Differences in Male Wage Inequality: Institutions Versus Market Forces" NBER Working Paper No. 4678.
- [6] Burdett, Kenneth. and Melvyn Coles (1995); "Marriage and Class" University of Essex Mimeo.
- [7] Davis, Steve (1995); "The Quality Distribution of Jobs in Search Equilibrium" University of Chicago Mimeo.
- [8] Diamond, Peter (1982); "Aggregate Demand Management in a Search Equilibrium" *Journal of Political Economy* Vol 90, pp 881-94.
- [9] Jovanovic, Boyan (1979); "Job Matching and the Theory of Turnover" *Journal of Political Economy* Vol 87, 972-990.
- [10] Juhn, Chinhui, Kevin M. Murphy and Brook Pierce (1993); "Wage Inequality and the Rise in Returns to Skill" *Journal of Political Economy* Vol 101, pp 410-442.aper No. 4297.
- [11] Katz Lawrence and Kevin Murphy (1992); "Changes in Relative Wages: Supply and Demand Factors" *Quarterly Journal of Economics.*, Vol 107, pp35-78.

- [12] Katz Lawrence, Gary W. Loveman and David G. Blanchflower (1995); "A Comparison of Changes in the Structure of Wages in Four OECD Countries" in Richard Freeman and Lawrence Katz (editors *Differences and Changes in Wage Structures* National Bureau of Economic Research, University of Chicago Press.
- [13] Kremer, Michael and Eric Maskin (1996); "Segregation By Skill and the Rise in Inequality" MIT Mimeo.
- [14] Levy, Frank and Richard Murnane (1992); "U.S. Earnings Level and Earnings Inequality: A Review of Recent Trends and Proposed Explanations" *Journal of Economic Literature* Vol 3, 1333- 1381.
- [15] Levy, Frank and Richard Murnane (1995); "Skills For A Middle Class Wage", MIT Sloan School Mimeo.
- [16] Mortensen, Dale (1982); "Property Rights and Efficiency in Mating, Racing and Related Games" *American Economic Review*, Vol 72, 968-979.
- [17] Murphy Kevin and Robert Topel (1987); "The Evolution of Unemployment in the United States: 1968-1985" *NBER Macroeconomics Annual* pp 7-58.
- [18] Nickell, Steve and Brian Bell (1995); "The Collapse in the Demand For the Unskilled and Unemployment Across OECD Countries" *Oxford Review of Economic Policy*, Vol 11, pp 40-62.
- [19] OECD (1994); *OECD Job Study; Evidence and Explanations*, Volumes 1 and 2
- [20] Pissarides, Christopher (1990); *Equilibrium Unemployment Theory*, Basil Blackwell.
- [21] Ruhm, Christopher (1991); "Are Workers Permanently Scarred by Job Displacements" *American Economic Review* Vol 81, 319-23.
- [22] Rumberger, R. W. (1981); *Overeducation in the U.S. Labor Market*, New York, Praeger.
- [23] Saint-Paul, Gilles (1993); "Are the Unemployed Unemployable" DELTA Mimeo

- [24] Sattinger, Michael (1993); "Assignment Models of Distribution of Earnings" *Journal of Economic Literature* Vol 3, pp 831-880.
- [25] Sattinger, Michael (1995); "Search and the Efficient Assignment of Workers to Jobs" *International Economic Review*.
- [26] Shimer Robert and Lones Smith (1996); "Heterogeneity, Matching and Search" MIT Mimeo
- [27] Sicherman, Nachum (1991); "Overeducation in the Labor Market" *Journal of Labor Economics* Vol 9, pp 101-122.
- [28] Statistical Abstract of the United States (1995), Bureau of the Census.
- [29] Topel, Robert H. and Michael P. Ward (1992); "Job Mobility and the Careers of Young Men" *Quarterly Journal of Economics* Vol 107, pp 439-480.

FIGURE 1

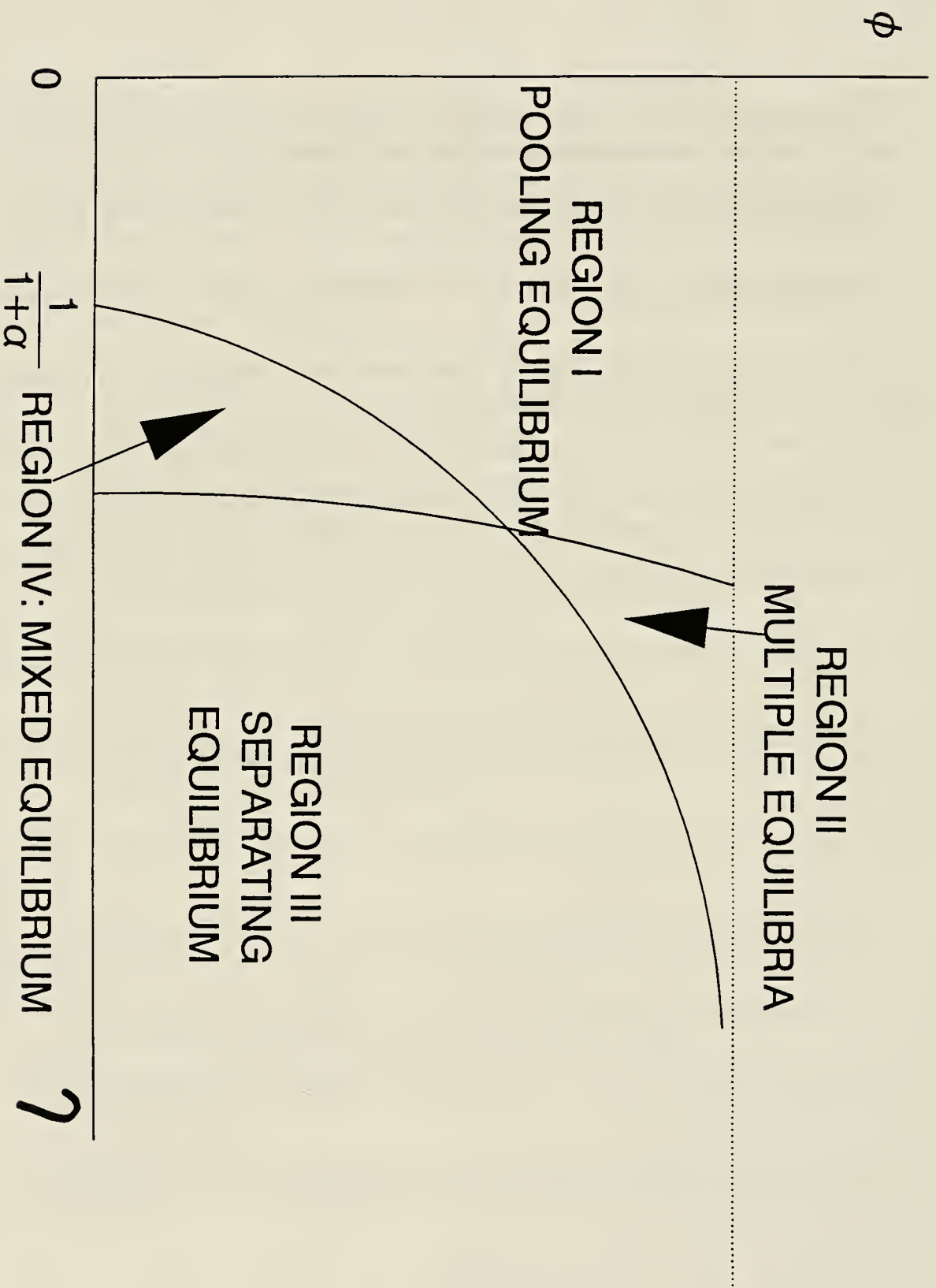



3 9080 00988 2058

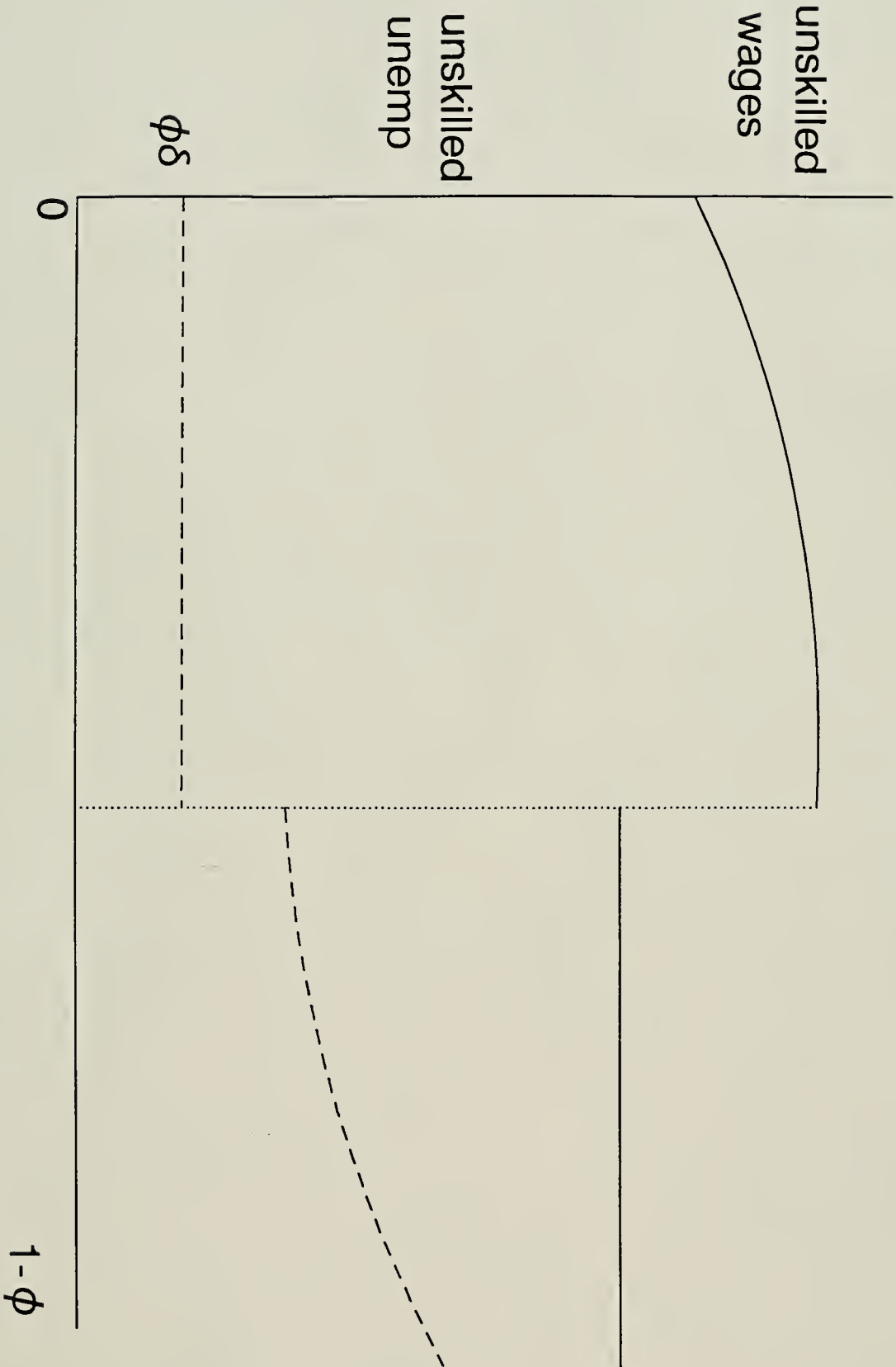
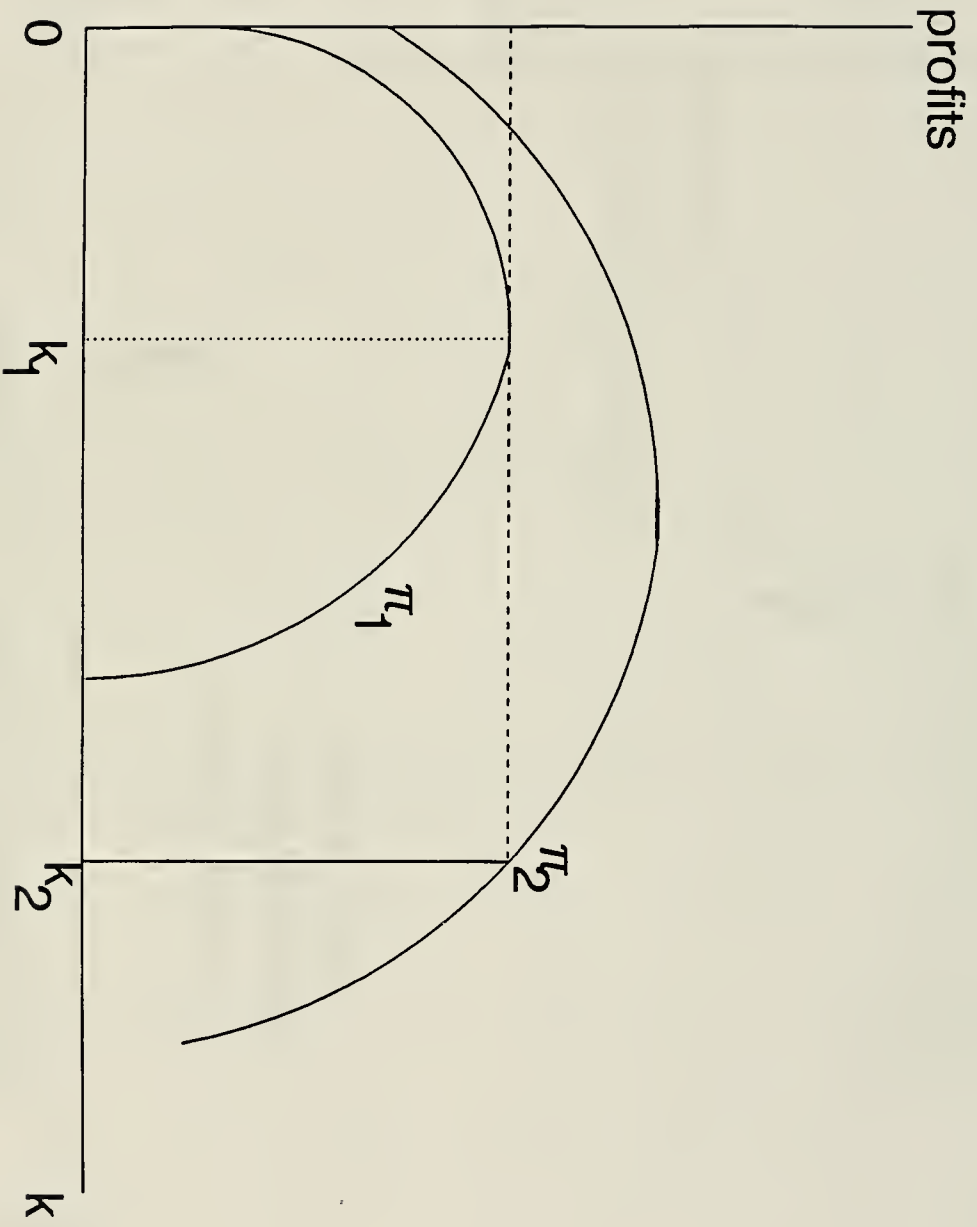

FIGURE 2

FIGURE 3



Date Due

--	--	--

Lib-26-67

