

LOW-COST, LOW-INCOME HOUSING IN NIGERIA

by

J. O. Chike Enwonwu

Diploma: Institute of Roads and Bridges - Moscow

Submitted in Partial Fulfillment
of the Requirements for the
Degree of Bachelor in
Architecture

at the

MASSACHUSETTS INSTITUTE OF TECHNOLOGY

June 1970

Signature of Author 0.

Certified by Thesis Supervisor

Accepted by Chairman, Departmental Committee on Graduate Students

Rõtch





Room 14-0551
77 Massachusetts Avenue
Cambridge, MA 02139
Ph: 617.253.2800
Email: docs@mit.edu
<http://libraries.mit.edu/docs>

DISCLAIMER OF QUALITY

Due to the condition of the original material, there are unavoidable flaws in this reproduction. We have made every effort possible to provide you with the best copy available. If you are dissatisfied with this product and find it unusable, please contact Document Services as soon as possible.

Thank you.

Text quality is poor in some spots. This is the best copy available.

LOW-COST, LOW-INCOME HOUSING IN NIGERIA

by

J. O. Chike Enwonwu

Submitted to the Department of Architecture on June 4, 1970, in partial fulfillment of the requirement for the degree of Bachelor in Architecture.

ABSTRACT

This thesis develops a conceptual framework of low-cost, low-income housing in a rapidly urbanizing area of Africa, Onitsha, Nigeria. The communities in this area do not possess, nor can they mobilize resources to build complete modern standard units for their low-income groups. In response to this, the thesis concentrates on what type of housing and dwelling unit standards, they can afford under their present conditions.

The first part of this work provides a picture of the existing conditions and the living standards of a selected group, typical of this urbanizing community. Based on its evolutionary housing trends during the past seven decades, a theory of development pattern was put forward.

Progressively upgraded housing is argued as a desirable development pattern, as opposed to "instantly" built houses. Based on this proposal, an incremental housing system which sets minimum standards and goals is designed and evaluated.

The proposed housing model aims at providing some scope for the architect or planner to determine concrete guidelines when building for low-income groups in similar areas. This scheme strives to answer all the questions about the future mobility of the beneficiaries, and also, to amplify the scope of current thinking in the field of progressive, low-cost, low-income housing.

Thesis Supervisor: Professor E. B. Allen
Title: Assistant Professor of Architecture
Thesis Advisor: Professor J. F. C. Turner
Title: Lecturer of Urban Planning

Dean Lawrence B. Anderson
School of Architecture and Planning
Massachusetts Institute of Technology
Cambridge, Massachusetts 02139

June 2, 1970.

Dear Dean Anderson,

In partial fulfillment of the requirements for the degree of Bachelor in Architecture, I herewith submit my thesis entitled: "Low-Cost, Low-Income Housing in Nigeria".

Sincerely,



J. O. Chike Enwonwu

ACKNOWLEDGMENTS

I wish to express my sincere thanks and gratitude to the following whose assistance has been invaluable during my period of study at M.I.T., and in the preparation of this thesis.

Members of the Faculty of M.I.T. School of Architecture and Planning who have given advice and criticism;

Professor Lawrence B. Anderson, Dean of the School of Architecture and Planning; Professor E. B. Allen, and Professor J. C. Turner in their thoughtful guidance and encouragement during the development of this thesis.

I also thank Miss Madeleine Leullier for her assistance in typing it.

TABLE OF CONTENTS

	Page
TITLE	i
ABSTRACT	ii
LETTER OF TRANSMITTAL	iii
ACKNOWLEDGEMENTS	iv
TABLE OF CONTENTS	v
LIST OF ILLUSTRATIONS	vii
CHAPTER 1 - INTRODUCTION	1
CHAPTER 2 - BACKGROUND INFORMATION	7
2.1 - Historic and Geographic Information (Onitsha, Nigeria)	7
2.1.1 - Demographic, Economic, and Social Information	8
2.2 - A Locality: Modebe Layout, Onitsha	16
2.2.1 - Housing Conditions and Living Patterns	16
2.2.2 - Existing Conditions: Modebe Layout	17
2.3 - Survey of Locally Available Building Materials	26
2.3.1 - Local Building Method	27
CHAPTER 3 - EVALUATIONS	30
3.1 - Factors Contributing to Housing Problems	34
3.2 - Aspects of Housing Inherent from Existing Conditions	35
CHAPTER 4 - PROPOSALS	37

	Page
4.1 - Proposal for Progressive (Incremental) Scheme for Low-Cost, Low-Income Housing	39
4.1.1 - Disadvantages of Instant (Fully Built) Houses for Low-Income Groups	39
CHAPTER 5 - GUIDELINES FOR IMPLEMENTATION OF A PROGRESSIVE HOUSING SCHEME	41
5.1 - Tenure (Rental, Lease, and Freehold)	42
5.2 - Landuse Pattern	45
5.3 - Dwelling Unit Types 'A' and 'B'	50
5.3.1 - Phases of Progressive Development in Construction of Dwelling Units Minimum Standards	50
CHAPTER 6 - EVALUATION OF DEVELOPMENT	57
6.1 - Landuse Pattern (Completion Stage)	57
6.1.1 - Assumptions (Proposed Development) Stage 1	59
6.1.2 - Assumptions (Proposed Development) Stage 2	60
6.1.3 - Assumptions (Proposed Development) Stage 3	61
6.2 - Alternative Routes of Proposed Development	62
6.3 - Conclusions	65
APPENDIX 1 - DWELLING PLOTS ANALYSIS	66
APPENDIX 2 - CLASSIFICATION OF ROADS	75
BIBLIOGRAPHY	76

LIST OF ILLUSTRATIONS

Chapter		Page
1.	Map: Africa South of the Sahara before 1884 - Former Indigenous African Boundaries	3
2.	Map: Nigeria 1914 and 1965 - Cities with Population of 100,000 and more	5
	Map: Onitsha 1940 - Wards and Settlement Pattern	6
2.1	Chart 1: Climate (Temperature, Humidity, Rainfall, and Wind)	10
	Chart 2: Income Distribution Pattern (Occupation Types and % of Population)	11
	Chart 3: Provision of Housing Types by Income	12
	Chart 4: Age-Sex Distribution (Onitsha and Federal Nigeria)	13
	Chart 5: Population Growth (Onitsha and Federal Nigeria)	14
2.1.1	Drawing 1: Onitsha - Topography and Circulation, Landuse Pattern, and Income Pattern 1900 and 1965	15
2.2	Drawing 2: Locality Plan (Modebe Layout) - Stages of Development	21
	Drawing 3: Locality Landuse (Modebe Layout) - Stages of Development	22
	Drawing 4: Locality Circulation Pattern (Modebe Layout) - Stages of Development	23
	Drawing 5: Locality Segment - Landuse and Densities	24
	Drawing 6: Dwelling Group (Evolution Concept of the Compound) in three Stages	25
2.3.1	Illustration Traditional Type Dwelling (Bamboo Structural System)	29

Chapter		Page
5.2	Drawing 7: Site Plan (Concept of Subdivision)	47
	Drawing 8: Site Plan Stages of Development	48
	Drawing 9: Locality Segment - Proposed Landuse and Densities	49
5.3	Drawing 10: Dwelling Unit Type 'A' (Plans in three Stages)	52
	Drawing 11: Dwelling Unit Type 'A' (Plans, Elevations and Sections)	53
	Drawing 12: Dwelling Unit Type 'B' (Plans, Elevations, and Section)	54
	Drawing 13: Structural (Dwelling Unit Type 'A')	55
	Drawing 14: Utilities (Dwelling Unit Type 'A')	56
6.1.1	Chart - Assumption (Proposed Development) Stage 1	59
6.1.2	Chart - Assumption (Proposed Development) Stage 2	60
6.1.3	Chart - Assumption (Proposed Development) Stage 3	61
6.2	Fig. 1 and 2 - Age-Sex Distribution (Existing and Alternative Projection)	62
	Fig. 3 and 4 - Income Distribution (Existing and Alternative Projection)	63
	Fig. 5 - Trajectory (Family Status over time)	64
Appendix 1	Maximum-Minimum Plot Representation	73
	Plot Area Representation	74

CHAPTER 1

INTRODUCTION

In the developing areas of Africa, the magic words 'change' and 'progress' are encountered everywhere, spoken and represented in terms of various physical environment. Most of these countries are awakening from ages-deep-slumber, and are trying hard to catch up with the fast moving space age; chewing on too big a mouthful, but not daring to let go lest the 'meal' will be lost for ever. These are the places where things are happening now amidst gun-fire from military 'coup d'état', and the cries calling for 'sawaba', 'uhuru', and freedom, are ringing loud and clear.

In the confused state of these diverse activities, of fervent movements for socio-political change and stability, of the thirst for education and modern technology, the ways of the African seem as confused as ever. He is being urbanized at such a breath-taking pace, and in mixed ways and values, that he is faced with the problem of choosing between the old and the new ways of living, or abandoning both, or perhaps combining both to evolve his own unique environment. It has been difficult, and still too early, to judge or forecast a direction of progress in measures comparable to the industrialized nation's standards.

The African heritage of traditional community living, the extended family system, and the local administration patterns, which have been

pushed aside, or indiscreetly mixed with the 'European ways', have, but produced within the past few decades, disorder and coercion. Nevertheless, it is evident from all indications that the African state of mind needs help if it is to advance fruitfully in the various phases of modern technology.

Foreign experts in these developing areas are greatly handicapped in performing their highly desirable functions of innovation due to lack of working information. And although most of these experts are people of immense knowledge and technical know-how, with highly reputed performances within their own countries, or countries with similar conditions, their tasks are generally rendered very difficult when they are called upon to assist in these areas, owing to the social, economic, cultural, and environmental backgrounds. To help therefore, it is necessary to see the people as they truly are.

"The power to conceptualize, is the power to operate."

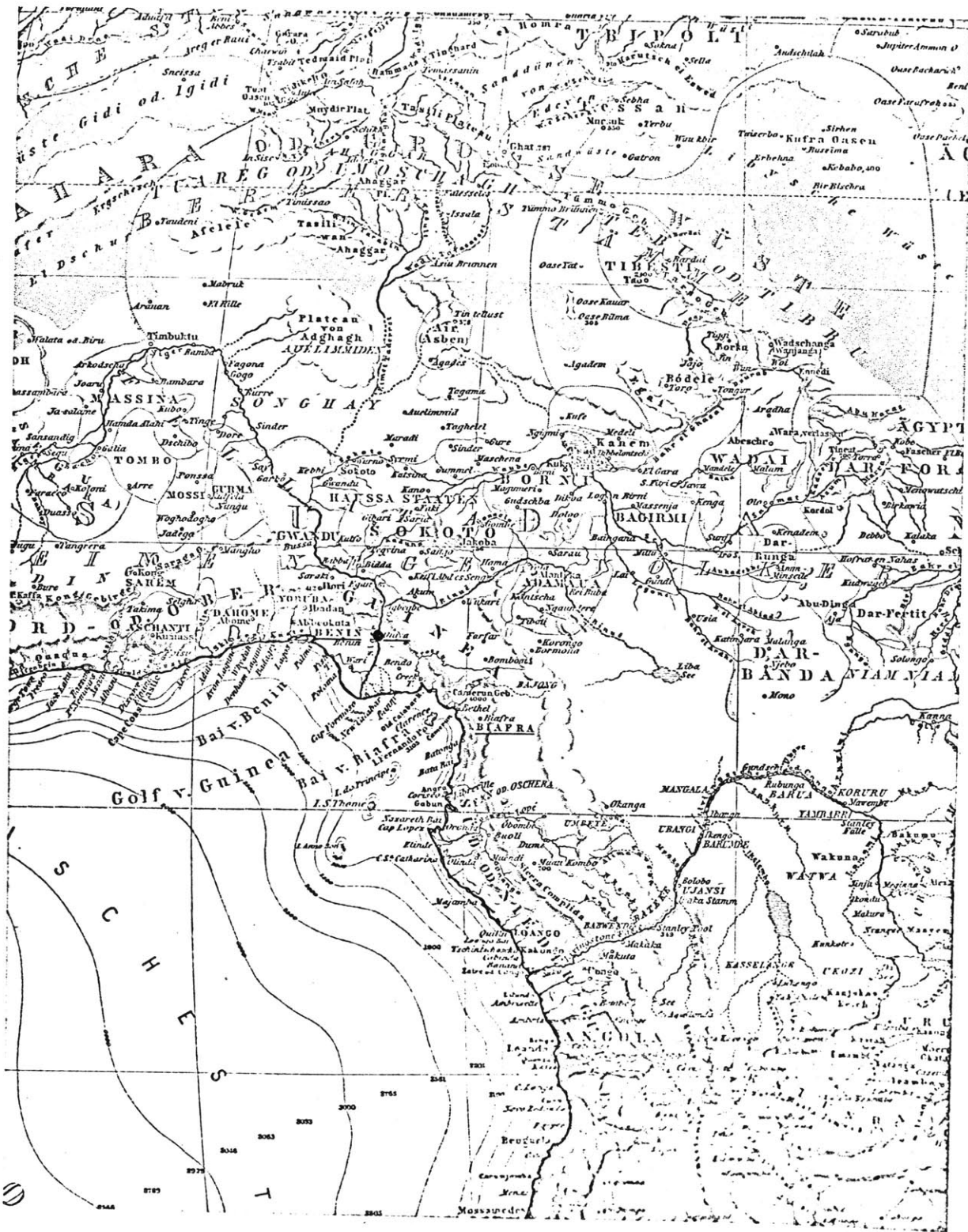

AFRICA SOUTH OF THE SAHARA BEFORE 1884

FORMER INDIGENOUS AFRICAN BOUNDARIES

MAP 1

MAP 2

AFRICA 1965
(Showing political subdivisions)

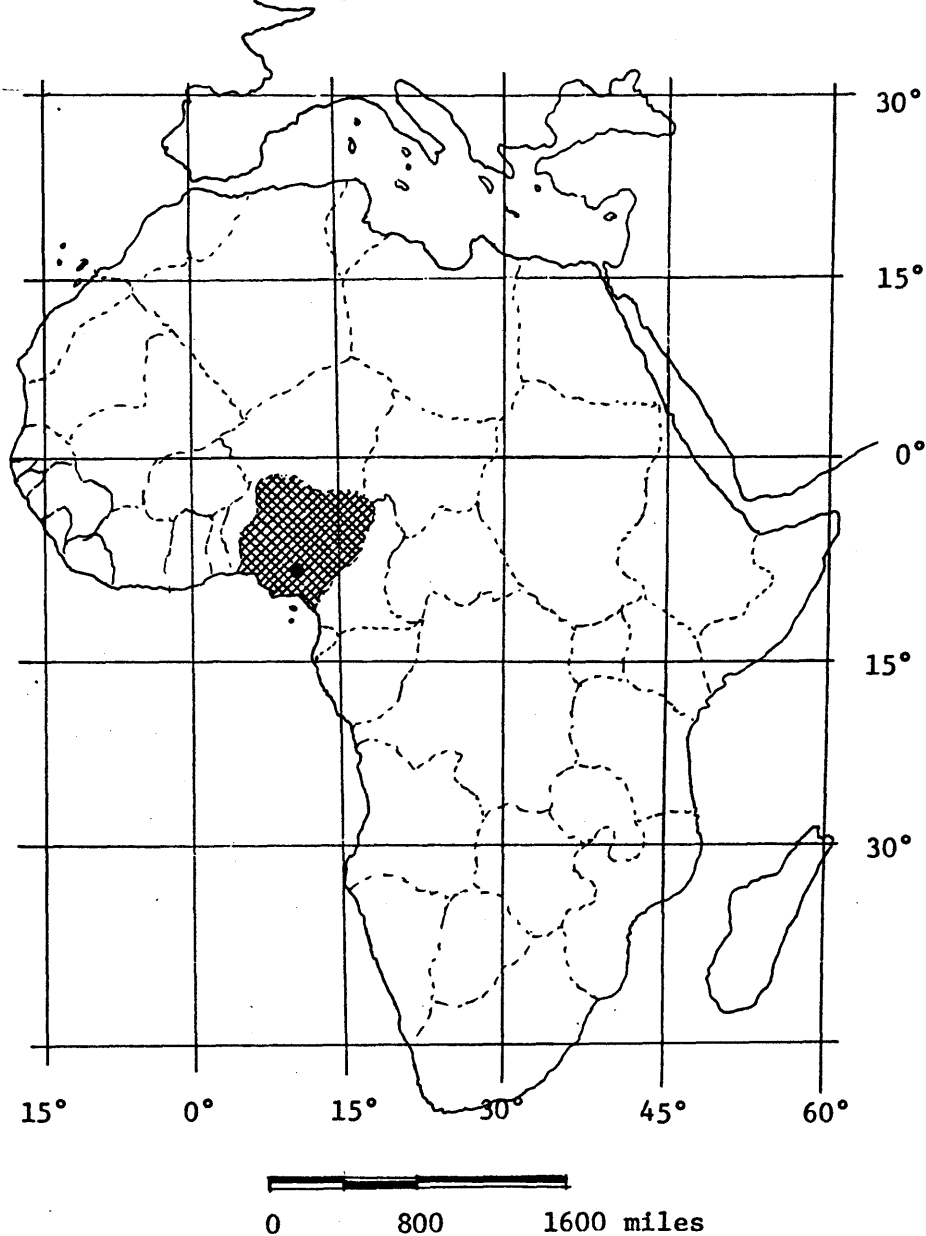

The political subdivision of Africa resulted from the Berlin Conference of 1884, the charter of which, granted rights to European powers to colonize Africa with the exception of the monarchies (like Ethiopia), who resisted colonization through wars. The area presently known as Nigeria, like similar other countries in Africa, south of the Sahara, until 1884, belonged to various African rules (as shown on Map 1, page). By 1885, Britain started amalgamating the various nationalities of the West African coast, and produced in 1914 the present Nigerian boundary.

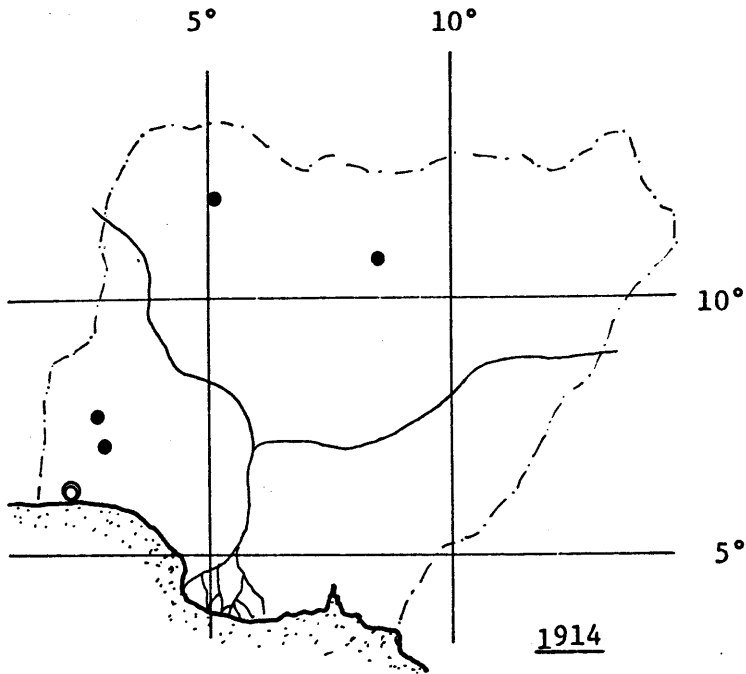

MAP 3
NIGERIA

- ⊙ National capital
- Other regional capitals
- Other cities with population over 100,000
- ★ Onitsha

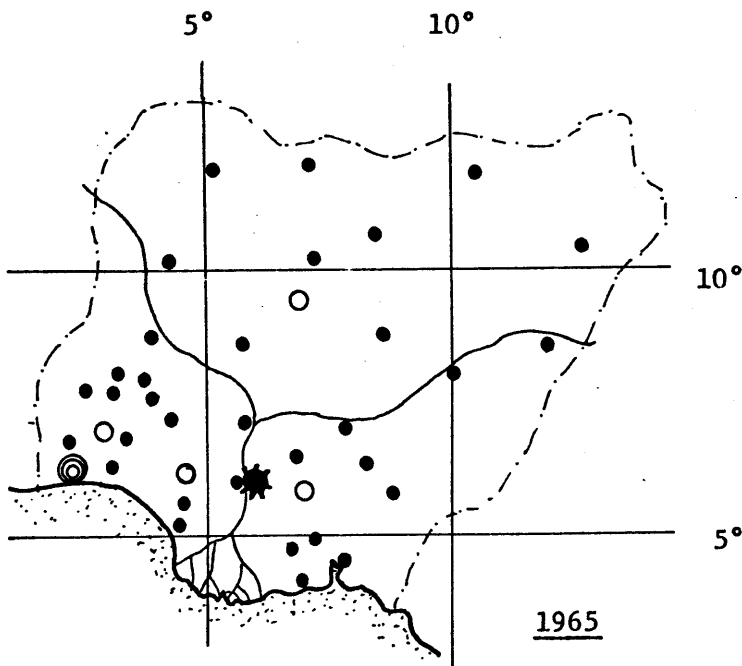

Area: 356,667 square miles (923,768 km²)
Population: 62,650,000 (1968 estimate)
Population (Lagos): 666,000 (1966 estimate)
Population (Onitsha): 225,000 (1966 estimate)
G.N.P. (Nigeria) 1967: \$ 5,4 billion

ONITSHA

MAP 4

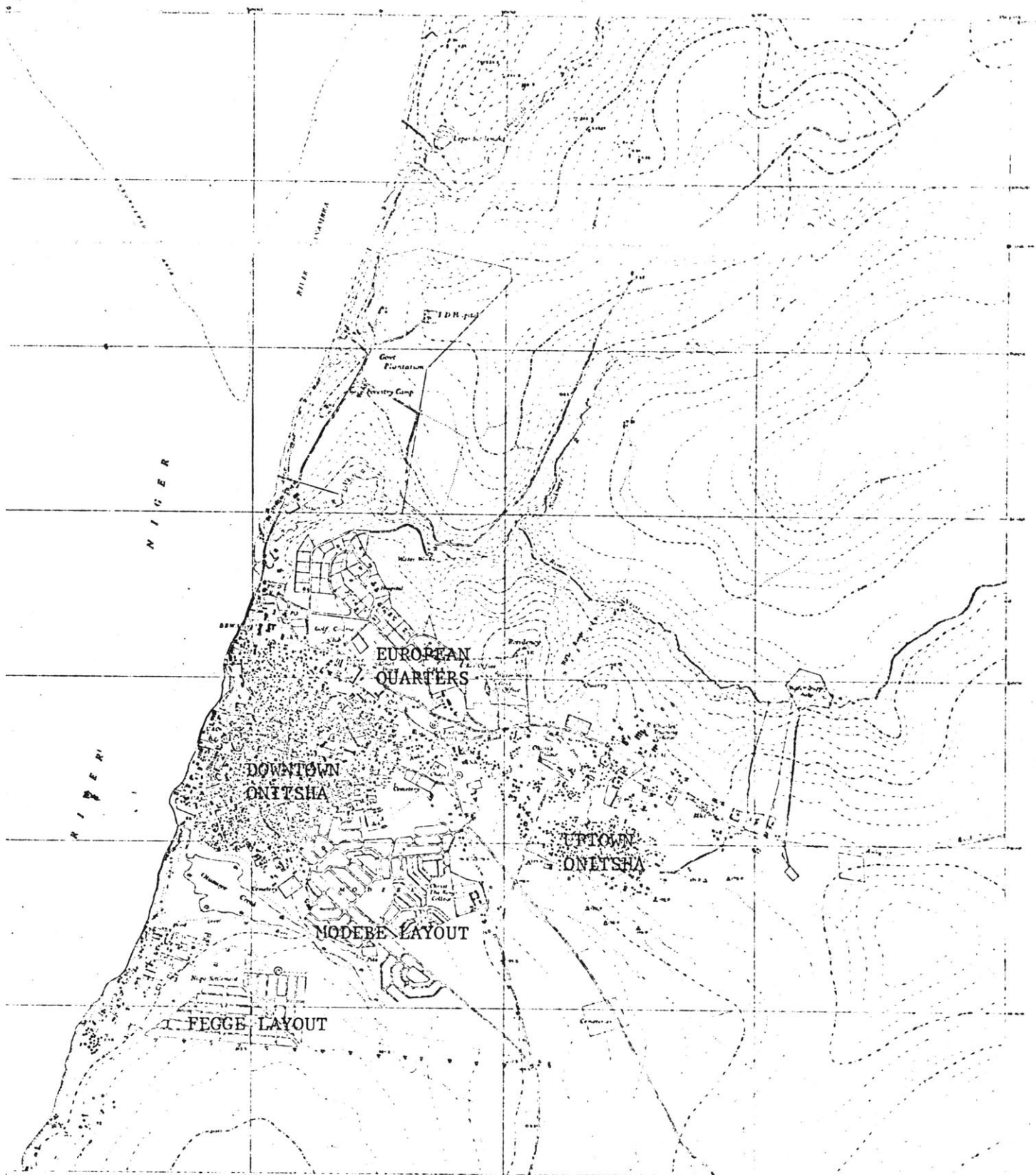

Compiled from a map sheet
Surveyed in 1921 by the Survey of Nigeria

Based on the map sheet No. 112,500

SCALE - 1:12,500

REFERENCE

Public Road	1 Lane Road	2 Lane Road	3 Lane Road	4 Lane Road	5 Lane Road	6 Lane Road	7 Lane Road	8 Lane Road	9 Lane Road	10 Lane Road
Canal	Drain	Water Course	Stream	River	Sea	Coast	Beach	Shore	Bank	Dike
Public Building	Private Building	Public Square	Private Square	Public Street	Private Street	Public Place	Private Place	Public Ground	Private Ground	Public Park
Public Road	1 Lane Road	2 Lane Road	3 Lane Road	4 Lane Road	5 Lane Road	6 Lane Road	7 Lane Road	8 Lane Road	9 Lane Road	10 Lane Road

CHAPTER 2

BACKGROUND INFORMATION

Low-cost housing for the low-income (popular) sector in a developing country is too complex a subject to be discussed without introducing the basic characteristics and concepts upon which a theory and model of development pattern are based. This section discusses the immediate past, and the existing conditions of living and housing trends.

2.1 - Historic and Geographic Information (Onitsha, Nigeria)

A traditional town¹⁾, and one of the oldest settlement areas in Nigeria, Onitsha was founded in the early 16th century by the dethroned King Aroli from the neighboring Benin Empire²⁾. After the 1884 subdivision of Africa by the European powers at the Berlin Conference, and after Nigeria became a British colony, Onitsha maintained its preeminence as an important trade center serving the Benin and the Ibo tribes of Central Nigeria. In 1956, due to its growing importance in commerce and to its strategic location on the banks of the River Niger, it had the largest open-air market in Africa.

1) Town: a cluster of village groupings (Map 1, page 3).

2) Map 1, page 3, Position of the Benin Empire before 18th century.

Onitsha, presently the largest city in East Central State of Nigeria, is situated on the banks of the River Niger, and lies on latitude 6° North, and longitude 6° East. The temperature is high all the year round, with very small variations between days and nights¹⁾.

2.1.1 - Demographic, Economic, and Social Information

The estimated population of Onitsha in 1965 was 225,000 (on assumption of 8% annual population increase over the 1962 official census figure of 175,000)²⁾. This increase in the Onitsha urban population was primarily facilitated by the migration of the nearby rural dwellers, in search of gainful jobs and educational opportunities.

The gross per capita industrial produce of the entire Eastern Nigeria (including Onitsha), was estimated at £100 (U.S. \$ 250) annually. About £1,500 (U.S. \$ 1,000 and \$ 7,500) annually³⁾. About £ 400 (U.S. \$ 1,000) is middle income in the national economy.

The city was divided into five wards based on ethnic groupings. Uptown Onitsha, on the northeast, one of the divisions was the location of initial settlement in this area. Downtown Onitsha (Otu), on the eastern front of the River Niger, formed the central business district. The other wards, the European quarters, Modebe layout, and fegge layout, were settled and established at much later dates⁴⁾.

1) Chart 1, page 10, CLIMATE.

2) Charts 2 and 3, pages 11 and 12, POPULATION TREND, AND DISTRIBUTION.

3) Chart 4, page 13, INCOME DISTRIBUTION.

4) Map 4, page 6, ONITSHA.

All five wards were administered by a central municipal authority. The Eastern Nigeria Regional Government which controlled the public works and housing departments, appointed the local or municipal government. The budget for such works, usually limited, was provided from taxes and foreign loans, and was administered through the regional government in a rather ineffective process of comprehensive planning. The municipality did not have much authority over the older built-up areas. The most recent planning and housing works were carried out by private developers and small contractors serving as agents of the local government.

A large number of the lower income households lived in rented rooms within four kilometers of the central business district, while others occupied owned houses in low-density areas on the periphery of the town. The upper income sectors were distributed between the Uptown Onitsha, and the European quarters¹⁾.

Property value was low. The buying price of land varied from £100 to £500 (U.S. \$250 to \$1,000) per plot size about 20×50 meters. The cost of development per square meter of built space was estimated at fifteen shillings (U.S. \$2) in 1965.

There has been an entire shift in population trends and overall socio-economic mobility because of the Nigeria-Biafra War (May 1966 through January 1970).

1) Map 4, page 6, Topography and Circulation - Onitsha, Nigeria.

CLIMATE

The climate is essentially tropical, relatively high temperatures all the year round (between the 70's and 90's) with slight variations.

Comfort range is between 65°F and 85°F through a range of relative humidity of 40% to 80%.

Sun shines all the year round. Rainfall is torrential and lasts for several hours, during which period the streets are flooded.

There are two predominant seasons in the year: the rainy season (April through October), characterized by continuous stormy rainfalls, and the dry season (November through March) marked by occasional drizzles and the 'northeast monsoon' winds.

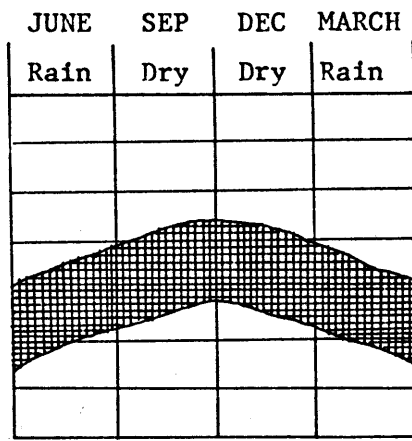

Humidity in %

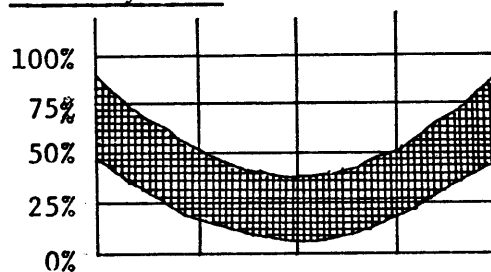

Rainfall in mm

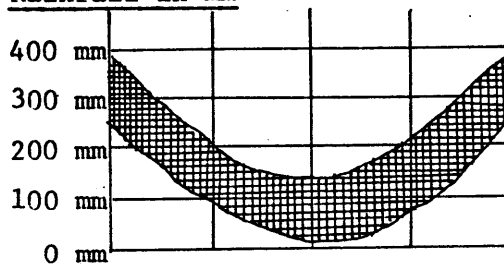

Wind

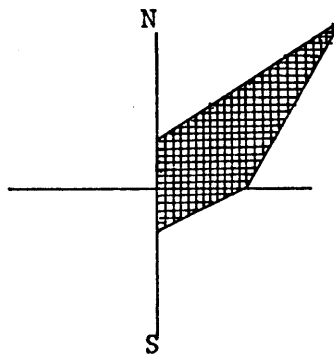

CHART 1

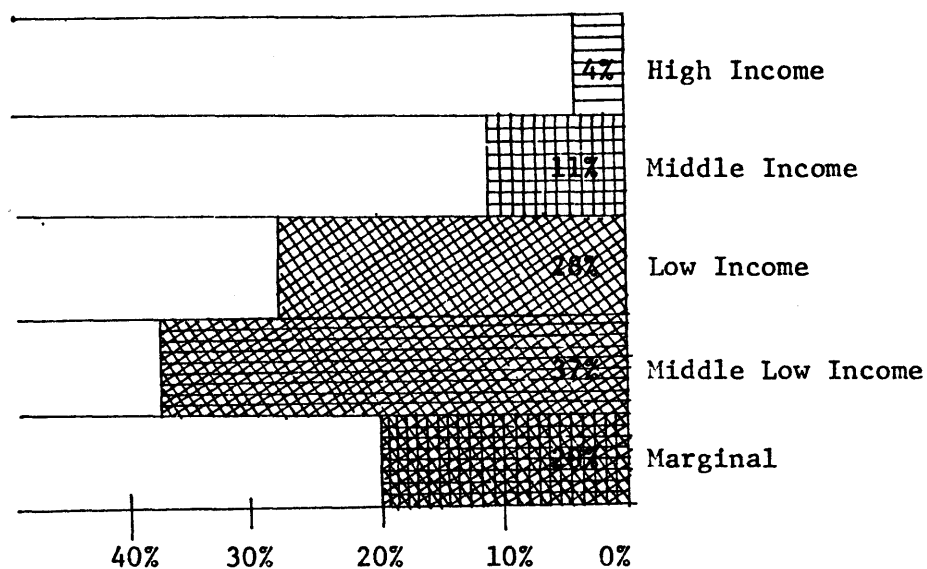
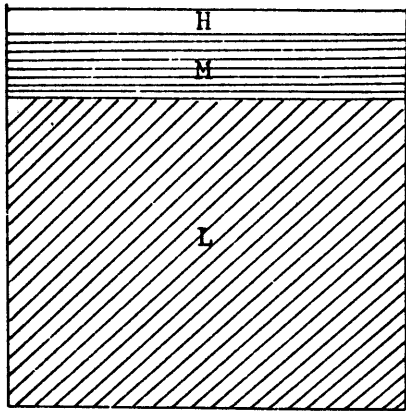

CHART 2
INCOME DISTRIBUTION PATTERN

Income Group	Occupation	Annual Income Distribution	% of Pop.
MARGINAL	<u>Unskilled</u> : porters, shoe repairs, less than domestic servants, garbage men...	£100 (US \$250)	20%
MIDDLE LOW	<u>Unskilled to Semi-skilled</u> : construction laborers, mechanics, night-soil collectors, peddlers.	£100 - £150 (\$250 - \$375)	37%
LOW	<u>Semi-skilled to Skilled</u> : construction workers, office workers, small shop owners, high school teachers.	£150 - £200 (\$375 - \$500)	28%
MIDDLE	<u>Skilled, Professionals</u> : small contractors, local government executives, etc...	£400 - £1000 (\$1000-\$2500)	11%
HIGH	<u>Professional and Temp. Foreign Advisers</u> : govt executives, business managers and directors.	Over £1000 (\$2500)	4%

National Average for Office Workers: £ 120 (\$300) annually.



Income Pattern by %
Onitsha 1964

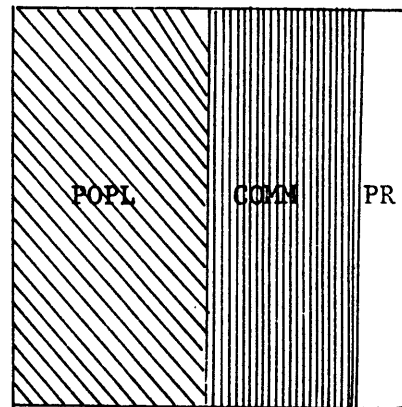

Types of Housing % Ratio
Onitsha 1964

H = High Income

M = Middle Income

L = Low Income

POPL = Popular Built

COMM = Commercially

PR = Private (institutional)

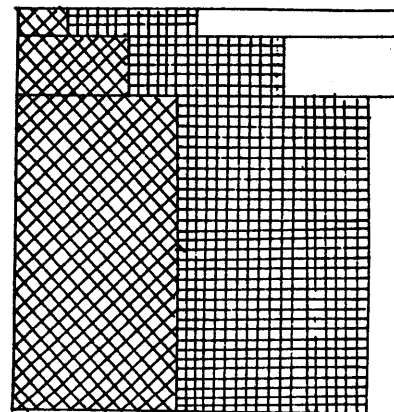

Provision of Housing
by Sectors

CHART 3

The first two diagrams illustrate the income distribution pattern of the city, and the ratio of type of housing currently available.

The third diagram correlates the above two, and illustrates the percentage type of housing occupied by the various sectors in the city.

Source of Information: Ministry of Economic Development, Enugu, Nigeria (1964 Review).

Quality of Information: Approximate.

AGE-SEX DISTRIBUTION

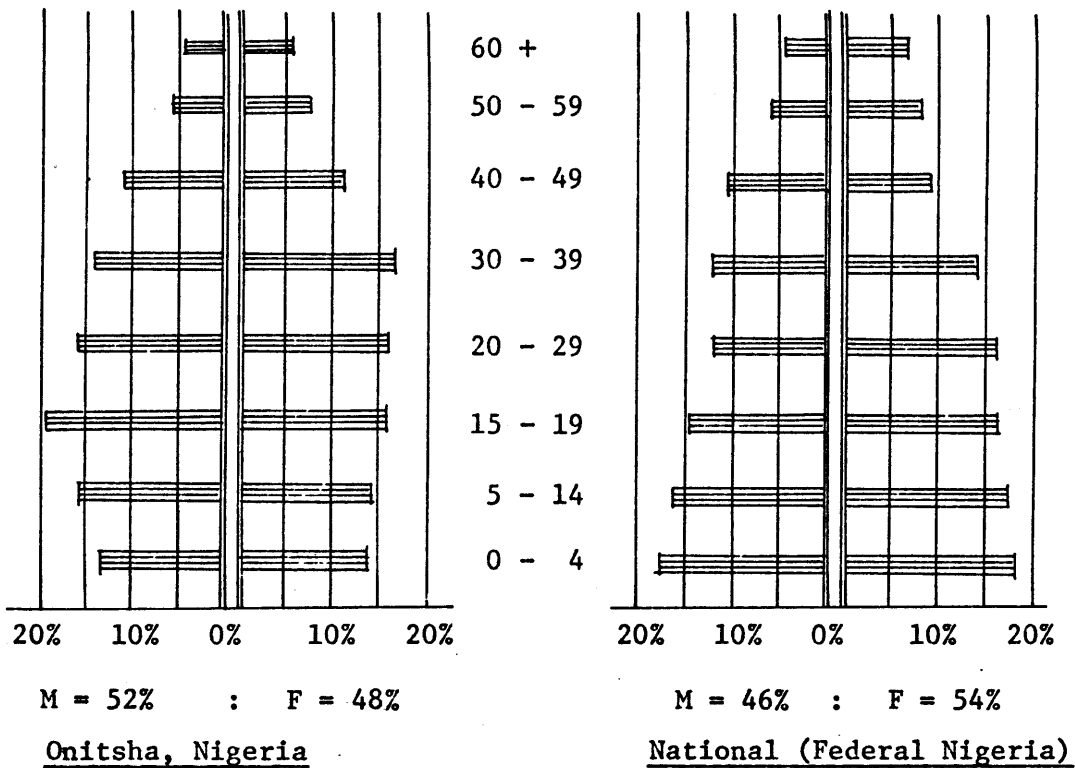

Source: Nigeria Census, 1962 - Quality of Information: Approximate

CHART 4

The age-sex population of Nigeria as a whole is a fairly normal distribution in all ages. The base of the 'pyramid' illustrates a fairly low infant survival as compared to many other developed nations.

The age distribution of the Onitsha Urban area is peculiar to similar urban areas in the country, with the exception of the federal capital, Lagos, and the regional capitals. The very small ratio of infants, and the relatively large proportion of adults, are accounted for by urbanization factors: most of the children of the seasonal or transient migrants to the Onitsha urban area born in the rural areas or in the permanent residences of these groups. In some cases, the wife may join the husbands in the city, leaving the children to the care of the grandparents.

Immigration usually starts at the early ages of 14 and upwards. A good proportion of these young migrants seek educational opportunities in the city, while the rest are employed as domestic servants, apprentices in various trades, etc.

CHART 5

POPULATION GROWTH

<u>Year</u>	<u>Total Population</u>
1920	21,000,000
1930	25,000,000
1950	56,000,000
1962	55,500,000
1968	62,650,000

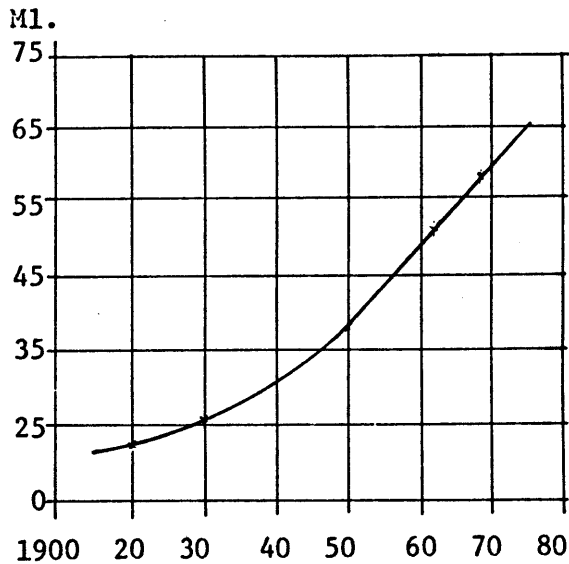

Country: Nigeria

Rate of Population Growth: Approximately 4% annually.

(Source: Nigeria Statistics, 1962)

(Quality: Approximate)

<u>Year</u>	<u>Total Population</u>
1920	10,300
1930	18,000
1950	77,000
1962	175,000
1965	225,000

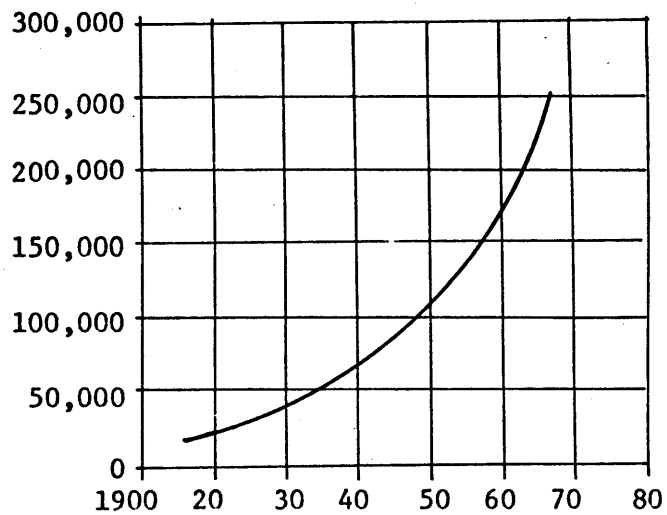

City: Onitsha, Nigeria

Rate of Population Growth: Approximately 8%. 4% increase is due to immigration from rural towns and villages and the other 4% is accounted for by the natural population growth forces (births).

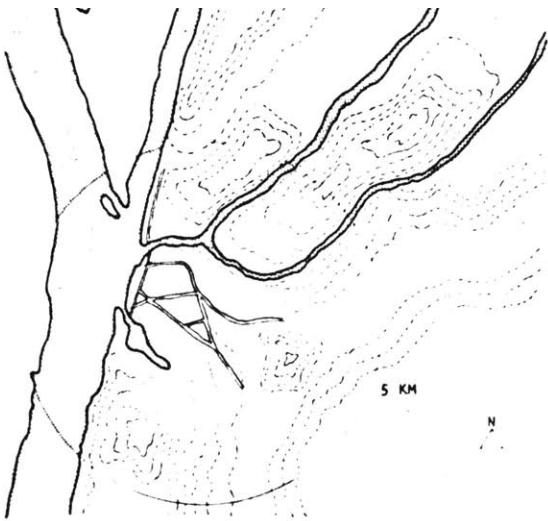

TOPOGRAPHY AND CIRCULATION 1900
URBAN AREA, ONITSHA, E.C.S. NIGERIA.

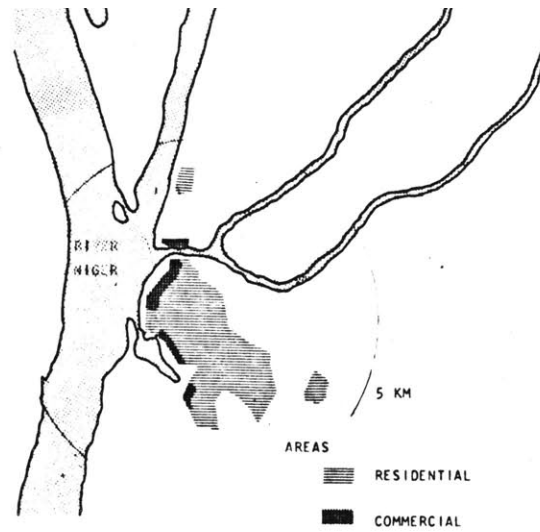

LAND-USE PATTERN 1900

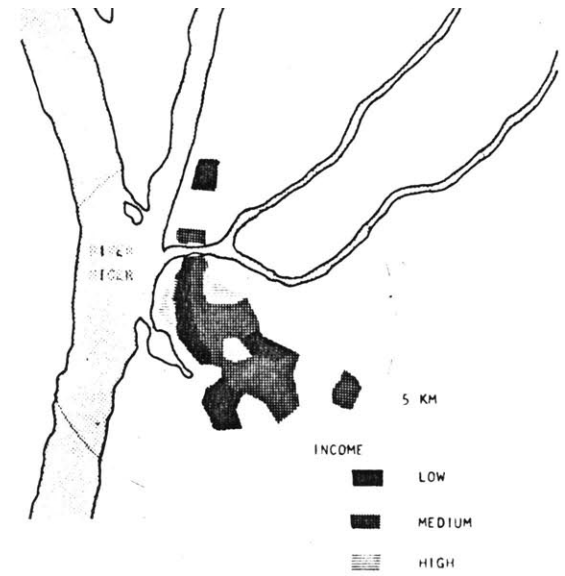

INCOME PATTERN 1900



TOPOGRAPHY AND CIRCULATION 1965
ONITSHA, E.C.S. NIGERIA

SOURCE: NIGERIA STATISTICS, 1965
QUALITY OF INFORMATION: APPROXIMATE.

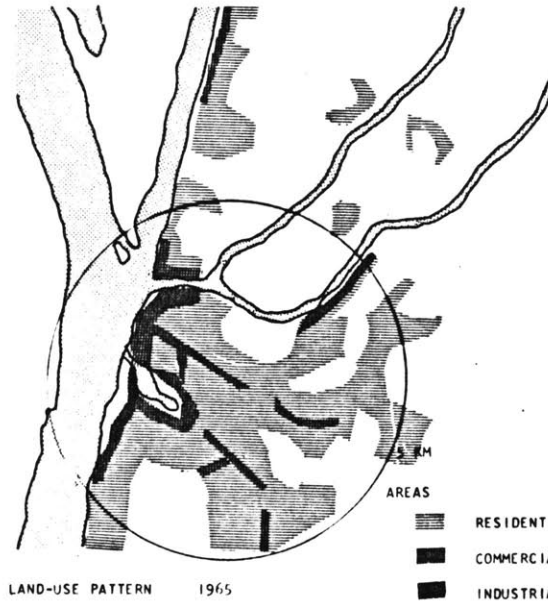

LAND-USE PATTERN 1965

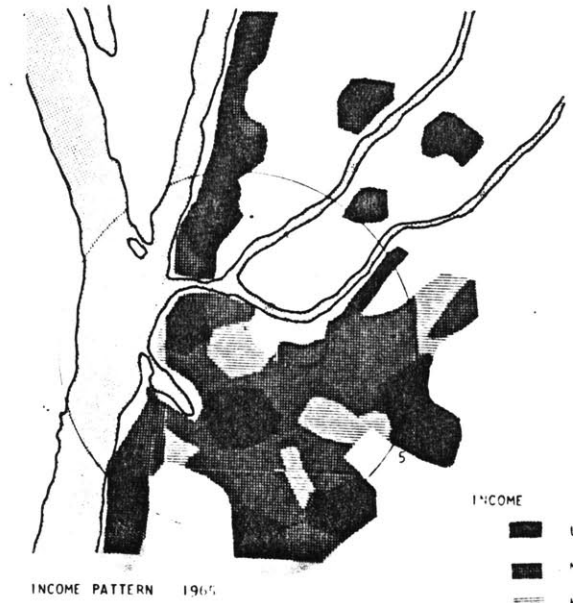

INCOME PATTERN 1965

LOW-COST, LOW-INCOME HOUSING IN NIGERIA
B.A.R.C.H. THESIS 1970
MASSACHUSETTS INSTITUTE OF TECHNOLOGY
CHIKE ENWONWE

2.2 - A Locality: Modebe Layout, Onitsha

Modebe layout selected to illustrate specific trends in past conditions and housing details, typifies a rapidly urbanizing neighborhood absorbing a large number of immigrating low-income households, who form about 70% of the total population. A similar ratio in the low-income households is very likely to be the pattern in the future establishment of new neighborhoods.

2.2.1 - Housing Conditions and Living Patterns

Modebe layout is located on the southeast of the town and within four kilometers of the business district. The land is fairly even, with heights ranging from 30 to 60 meters above sea level¹⁾.

The neighborhood was established in the 1940's through an influx of unskilled and semi-skilled migrants from the surrounding villages and nearby towns. Many of the older buildings existing by 1965 were constructed through traditional techniques and local materials²⁾. The newer ones made use of a combination and application of western plans, imported building materials, mixed with the available local building components. By 1960, this area had been completely occupied by dwellings³⁾.

Most households⁴⁾ were made up of extended or polygamous families. By 1965, there were about 15% of polygamous families in this neighborhood.

1) Map 4, page 6.

2) 2.3.1, page 27.

3) Drawing 2, page 21.

4) A household was composed of persons who were related to each other by blood or marriage, and who shared from a common pot.

But this trend seems to be on the decline (about 30% polygamous households were recorded for the same neighborhood in 1950). The decline was chiefly due to change in socio-economic conditions¹⁾.

On an average annual household income of £200 (U.S. \$ 500), it was just possible to maintain a family of seven, but difficult to build a house. In cases where land is inherited on this income per household, dwelling units of sandcrete blocks²⁾ could be built through artisan or small contractor development.

2.2.2 - Existing Conditions: Modebe Layout

The layout of the locality, shown in the last stages of its development³⁾, was an attempt by the municipal government to improve the apparent growth of the existing situation, the initial planning and erection of blocks having been done by individual or small group settlement decisions.

By 1965, an estimated 3000 or more families lived in this neighborhood of about 300 acres. The total population was estimated at 20,000. A large number of these belonged to aggregate and extended families.

Private dwellings occupied about 60% of the land. Most of the buildings facing the major roads were used commercially. The area is relatively well served with schools. Except for alleys, semi-public

1) Chapter 3, pages

2) Sandcrete blocks: made of fine grains of sand, and no coarse aggregate. The sand is usually some type of mud.

3) Drawings 2, 3, 4, and 5, page through page .

passages, and private courtyards, there are practically no public spaces within the locality.

Household ties were very strong because of the extended family relationships. There was considerable separation between the world of men and women in this community. The men would usually entertain their male guests in the living areas or in the front courtyards as may be the case, while the women received their female visitors in the domestic areas or the rear courtyards.

Family sizes ranged from two to twelve persons. An average of seven persons made up a family. Two or more families formed a household and lived in a compound¹⁾. A compound is a closed unit fenced or walled all around to a height of about four feet. The material used for construction of such an enclosure would either be mud, wood, or bamboo sticks. Within this enclosed space, dwelling units were located, joined to each other by long narrow corridors, or by open courtyards. The number of such structurally independent dwelling units varies with the number of persons in the household.

Inside the dwelling units, there was little in the way of furniture. Personal possessions were similarly scanty. Bicycles, for instance, formed valuable property if acquired. Livestock (goats, chickens, and ducks), could be seen running around in the compound. Some of the single family households were temporary migrants to the town. Their stay usually was very short, during which period they would acquire as much possessions

1) Drawing 6, page 25, Dwelling Group, Evolution of the Compound.

and savings as possible to take back to their rural villages. A good number of the single person households are often bread-winners for large families in the interlands. For these, the attraction of the urban town means acquisition of economic benefits which were otherwise impossible in the rural areas.

Personal incomes were relatively much lower than the towns average. The average annual household income was between £ 100 and £150 (U.S. \$ 250 and \$ 375), depending on the number of wage-earners in household.

The through streets and roads are accessible to motor vehicles. Pedestrian lanes exist on both sides of streets and roads, markedly isolated on the far sides by rainwater drainage gutters about three feet wide and three feet deep.

About 80% of the dwellings in Modebe layout are the 'compound' type houses, accommodating extended family type households. The units have a mixed-use function¹⁾. The initial construction was usually the largest unit. Subsequent additional structures aimed at meeting storage needs, or accommodation for new incoming migrant members of the extended family. The frontal rooms in some cases were used as shops, restaurants, or as whole-sale distribution stores.

Courtyards were predominant features of most dwelling houses. The rear or second yards serve as places for domestic activities and for cooking. Gas or electrical equipments were not commonly used. Pots for cooking were balanced over a tripod under which wood was burnt. Sewers

1) Drawing 6, page 25, Dwelling Group, Stages of Evolution.

were non-existent, and toilets were located at a convenient position in the rear of the lot or compound, providing an easy access for 'night soil' pick-ups.

Few windows existed, partly for fear of burglary, and partly because new structures were added to the side of existing window openings. The exterior door openings were therefore used to provide ventilation and light.

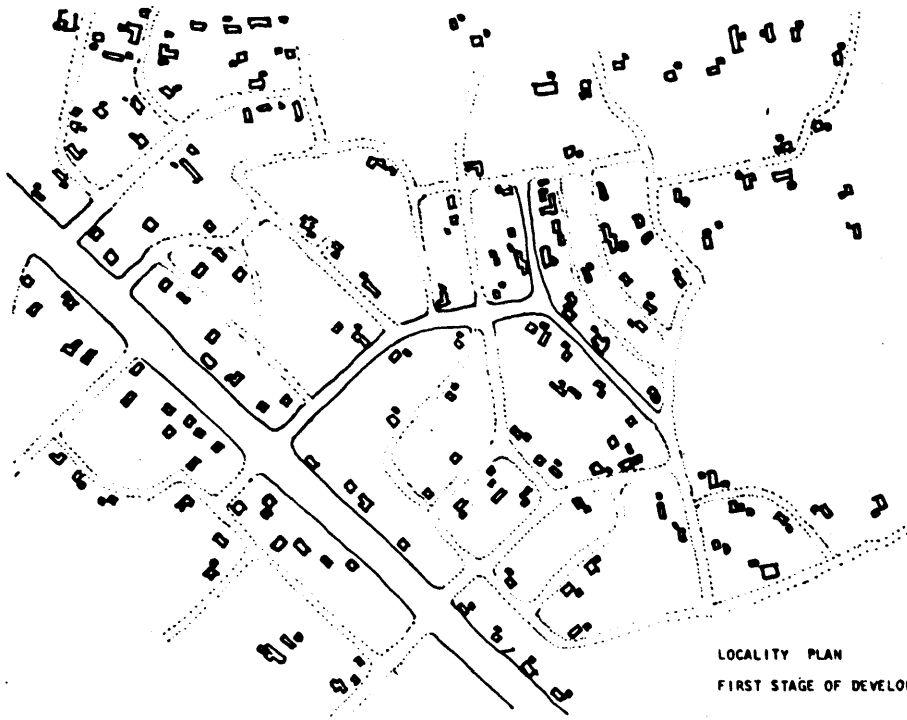

LOCALITY PLAN
FIRST STAGE OF DEVELOPMENT 1945

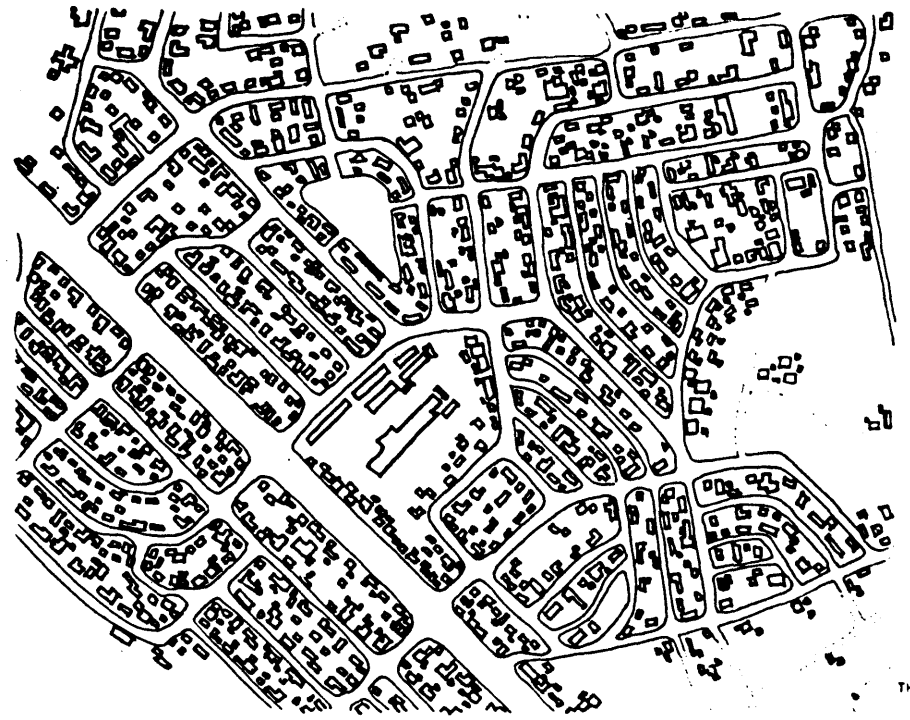

THIRD STAGE 1965

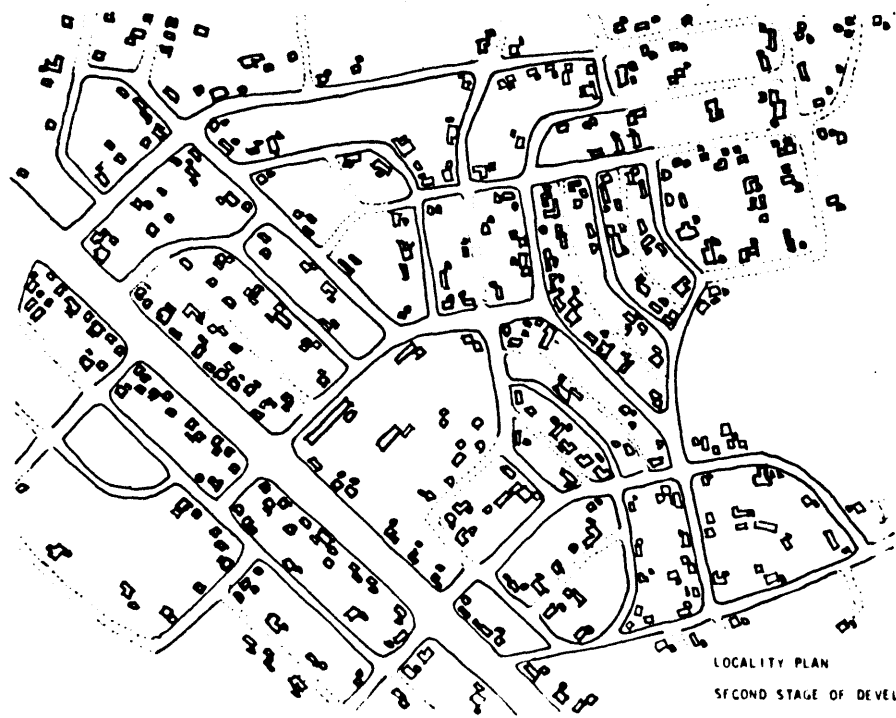
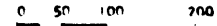

LOCALITY PLAN
SECOND STAGE OF DEVELOPMENT 1955.

LOCALITY PLAN
MODEBE LAYOUT, ONITSHA, F.C.S., NIGERIA
SOURCE: NIGERIA SURVEY 1965.
QUALITY OF INFORMATION: APPROXIMATE

LOW-COST, LOW-INCOME HOUSING IN NIGERIA
B.A. ARCH THESIS 1970
MASSACHUSETTS INSTITUTE OF TECHNOLOGY
CHIKE ENWONMAYI

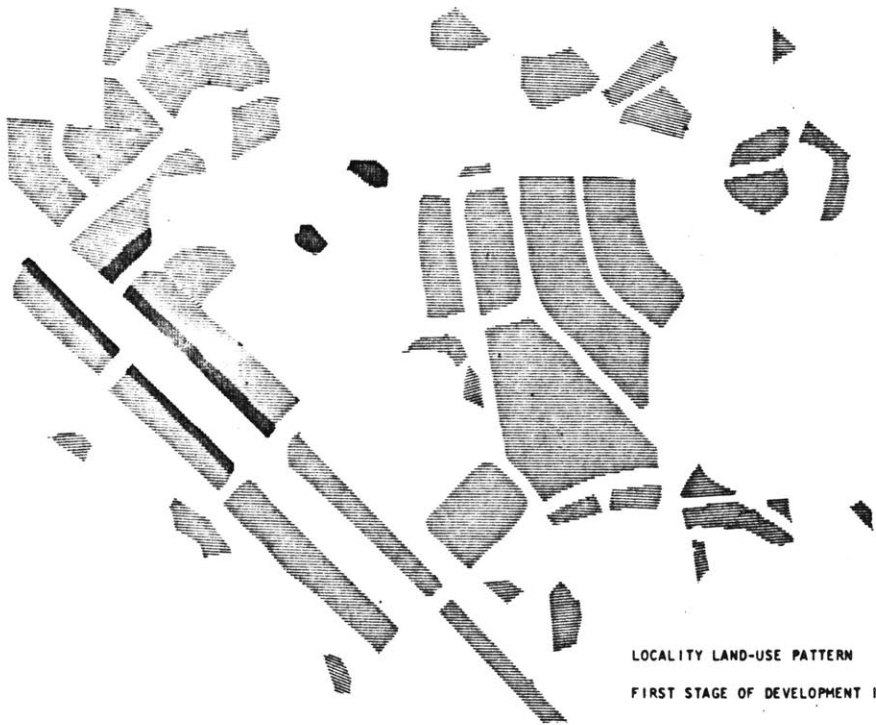

LOCALITY LAND-USE PATTERN
FIRST STAGE OF DEVELOPMENT 1945

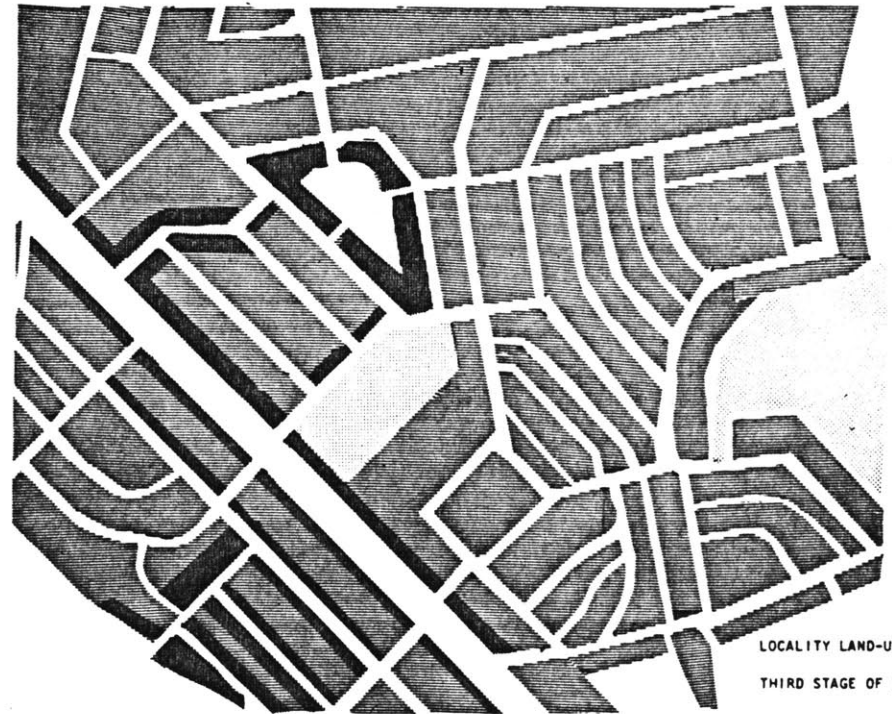

LOCALITY LAND-USE PATTERN
THIRD STAGE OF DEVELOPMENT 1965

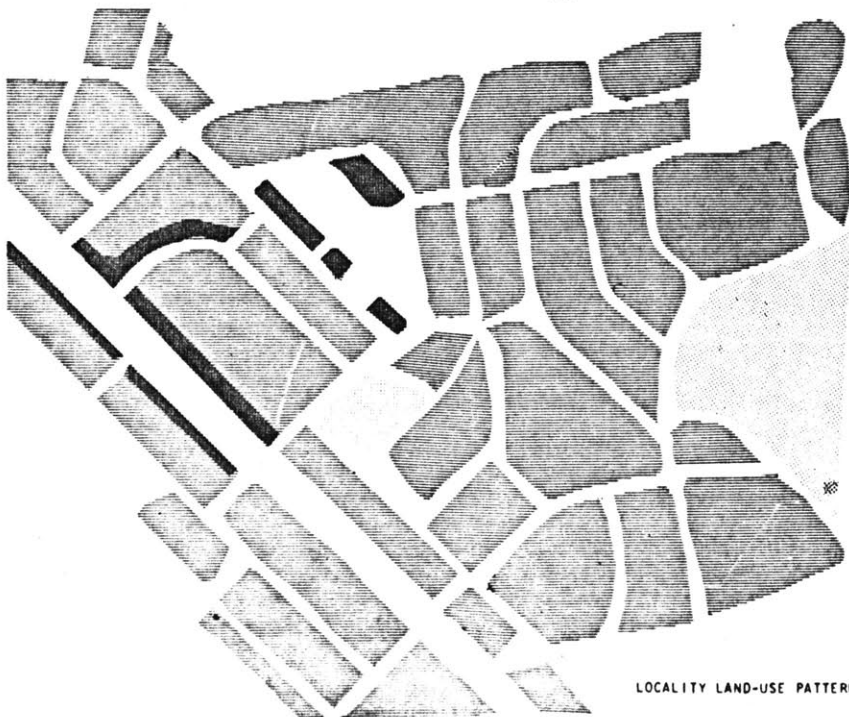

LOCALITY LAND-USE PATTERN
SECOND STAGE OF DEVELOPMENT 1955

AREAS
RESIDENTIAL
COMMERCIAL
INSTITUTIONAL

AREAS

RESIDENTIAL

COMMERCIAL

INSTITUTIONAL

0 50 100 200

AREAS	RATIOS IN %
RESIDENTIAL	58%
COMMERCIAL	8%
INSTITUTIONAL	9%
CIVIC CENTERS & OTHERS	6%
CIRCULATION	19%

LOCALITY LAND-USE PATTERN (THREE STAGES OF DEVELOPMENT)

MODEBE LAYOUT, ONITSHA, E.C.S., NIGERIA,

SOURCE: NIGERIA SURVEY 1965

QUALITY OF INFORMATION: ESTIMATE

LOW-COST, LOW-INCOME HOUSING, IN NIGERIA **3**
B.A.RCH THESIS 1970
MASSACHUSETTS INSTITUTE OF TECHNOLOGY
CHIKE ENWONWU.

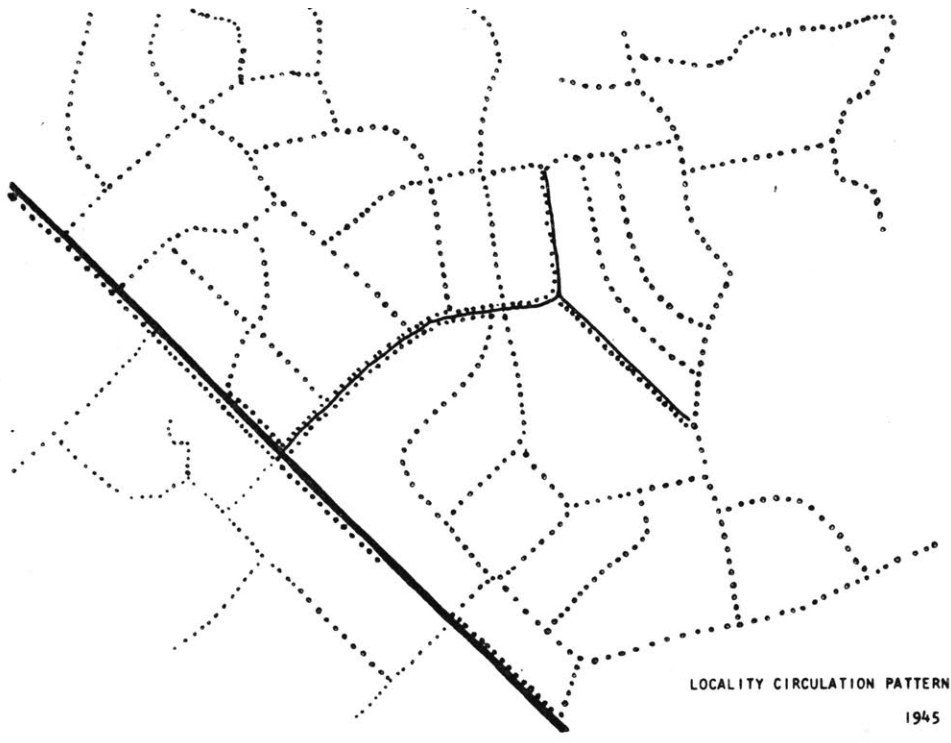

LOCALITY CIRCULATION PATTERN
1945

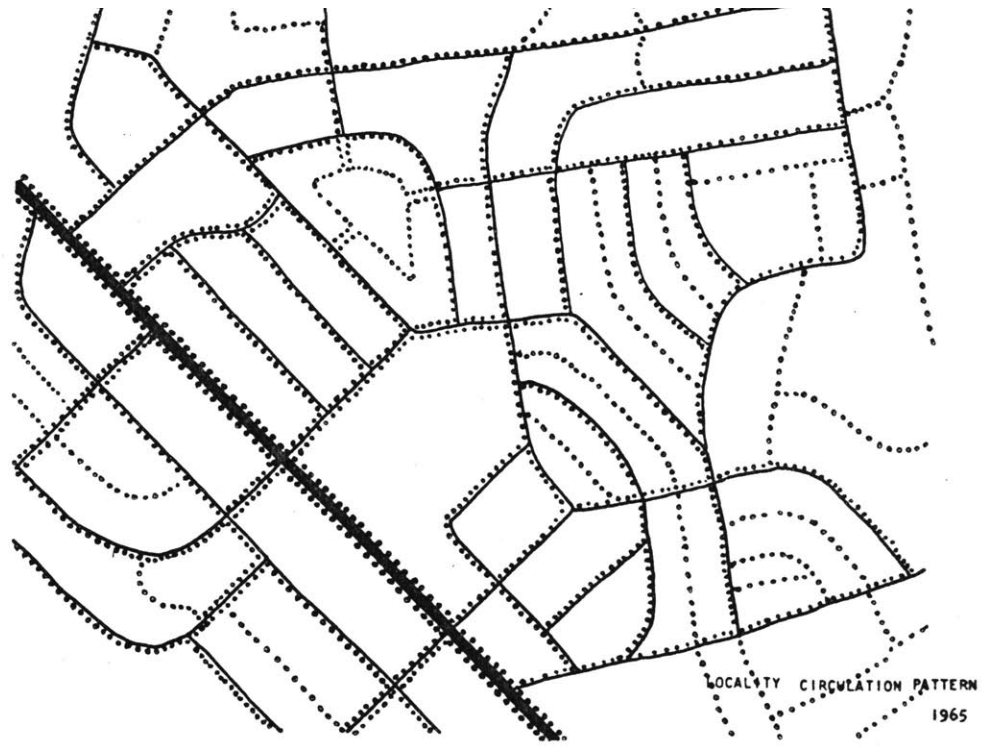

LOCALITY CIRCULATION PATTERN
1965

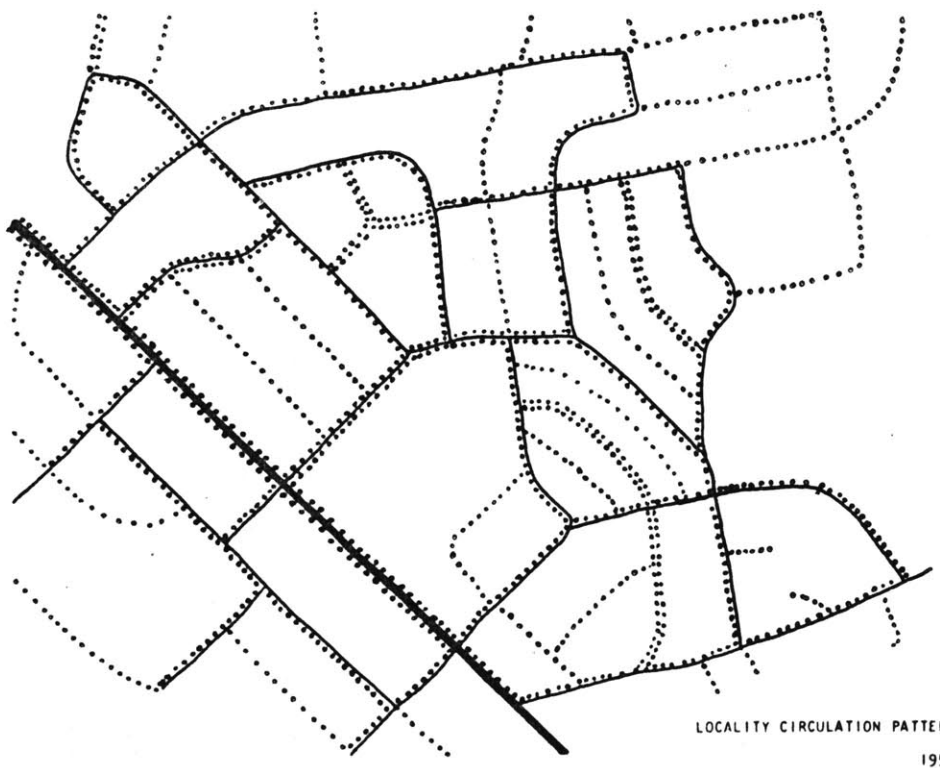

LOCALITY CIRCULATION PATTERN
1955

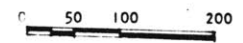

— VEHICULAR
 PEDESTRIAN

LOCALITY CIRCULATION PATTERN
MODEBE LAYOUT, ONITSHA, E.C.S. NIGERIA.
 SOURCE: NIGERIA SURVEY, 1965.
 QUALITY OF INFORMATION: APPROXIMATE

LOW-COST, LOW-INCOME HOUSING IN NIGERIA.
 B.A.RCH THESIS 1970
 MASSACHUSETTS INSTITUTE OF TECHNOLOGY.
 CHIKE ENWONWU



LOCALITY SEGMENT

A R E A S.	HECTARES	PERCENTAGE
PRIVATE OWNERSHIP		
DWELLING LOTS	9,40	58,8
COMMERCIAL; (MIXED / RESIDENTIAL)	1,20	7,5
INDUSTRIAL		
PUBLIC OWNERSHIP		
COMMUNITY CENTERS, PARKS, SCHOOLS,	2,03	12,7
CIRCULATION (STREETS, ALLEYS, ETC.)	3,36	21,0
	16,00 HA.	100

DENSITIES OF A TYPICAL BLOCK.

	NUMBER	HECTARES	N/HA.
LOTS	24	1,50	16,0
DWELLING UNITS	22	1,50	14,7
FAMILIES	60	1,50	40,0
PEOPLE (AVG. 7 PERSONS/FAMILY) (= 3 FAMILIES/ HOUSEHOLD)	422	1,50	140,0

SOURCE: NIGERIA STATISTICS, NIGERIA SURVEY 1965
 QUALITY OF INFORMATION: APPROXIMATE.



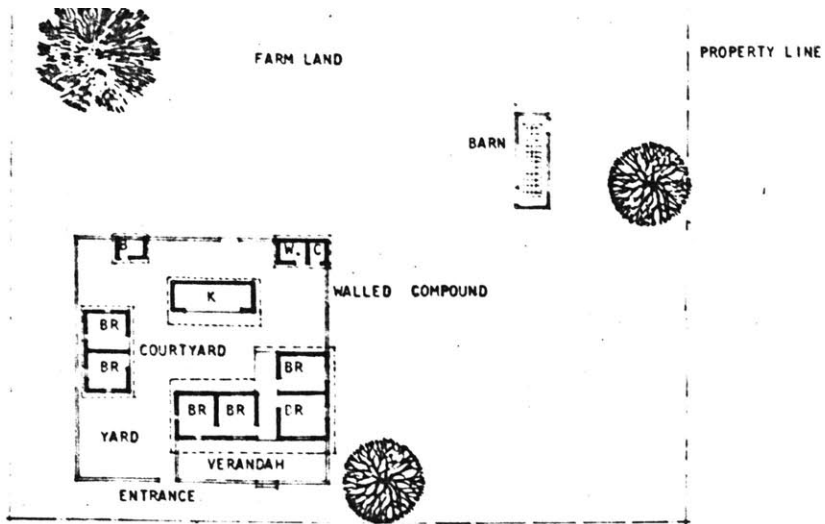

EVOLUTION CONCEPT OF THE COMPOUND

STAGE ONE 1945

AREA OF LOT: (32 X 32) = 1024 M²

NUMBER OF PERSONS: EIGHT

WALLS : WEIGHT BEARING MUD; ROOF TRUSS: BAMBOO, ROOFING: THATCH

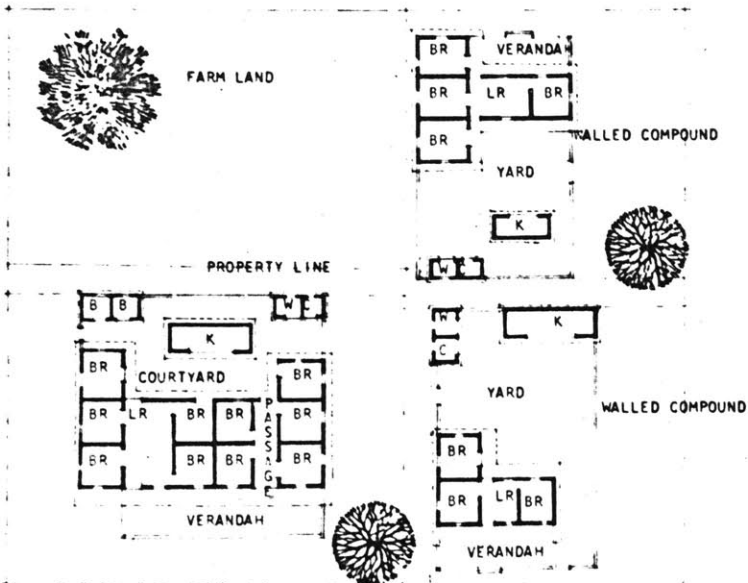

EVOLUTION CONCEPT OF COMPOUNDS

STAGE TWO 1955

NUMBER OF COMPOUNDS = 3

NUMBER OF PERSONS (TOTAL) = 35

WALLS; MASONRY BEARING, ROOFING: THATCH OR GALVANIZED STEEL

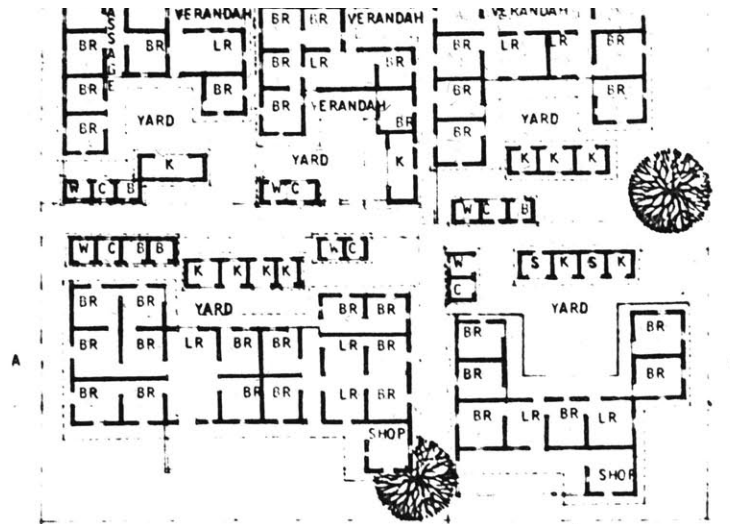

EVOLUTION; CONCEPT OF COMPOUNDS

STAGE THREE: 1965

NUMBER OF COMPOUNDS = 5 ; TOTAL NUMBER OF PERSONS: 70

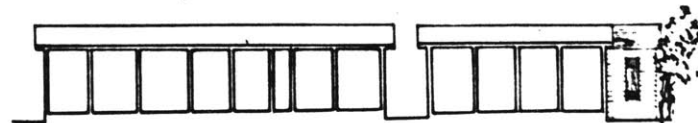

SECTION A-A

0 2 5 10 METER

LOW-COST LOW-INCOME HOUSING IN NIGERIA

B.A.R.C.H. THESIS 1970

MASSACHUSETTS INSTITUTE OF TECHNOLOGY

CHIKE ENWONJU.

2.3 - Survey of Locally Available Building Materials

The materials usually employed in building and construction works are:

- Foundations and walls: mud, bamboo posts, log timber, red brick, sandcrete and concrete blocks, and rocks.
- Flooring and coating: clay and clay tiles, cement and other components.
- Reinforcing: steel (very limited) and bamboo.
- Fastening: fiber cords from bark tree and palm trunk, and nails.
- Roof trusses: bamboo posts and log timber.
- Roofing: thatch (palm leaves, coconut leaves, and grasses), corrugated asbestos sheets, and galvanized sheets.

Locally obtainable materials and components:

- Cement: asbestos cement boards @ 4'x8' (1.20x2.40 m).
- Asbestos cement shingles @ 0.30x0.30 m (12"x12").
- Asbestos cement corrugated roofing @ 0.90x1.20 m (3'x4').
- Concrete and sandcrete blocks: 0.20x0.40 (9"x18").
0.15x0.40 (6"x18").
0.10x0.40 (4½"x18").
- Red brick: mud bricks at various standards.
- Clay tiles @ 0.15x0.15 m (6"x6").
- Log wood (timber and "iroko").
- Plywood doors and windows.
- Perforated wood for jalousis, etc.
- Rock.

Imported components:

- Steel rods, aluminium, metal windows and doors, and glass.
- Bathroom accessories; glazed tiles, sanitary equipment.
- Galvanized steel, fiberglass, mosaic, and ceramic tiles.

2.3.1 - Local Building Method:

The traditional local building style employed in this area embraces the use of logs as they come from the trees. The most common tools are machetes, axes, hoes (for digging foundations), and ladder.

For wall construction, vertical logs or bamboo posts are sunk in the ground and connected transversely with smaller poles which in turn are joined together by fiber ropes. This structure is then filled with sandcrete or mud on both surfaces. Thus, the wooden structure is protected from termites, and rigidity is added to the entire frame and structure through the surfacing material.

The roof span is generally very short in length, because of lack of a complex trussing technology. Roofs for single story units are usually constructed on the ground, lifted into position, fastened and then thatched.

Thatch made out of palm leaves is used in most cases. Thatching grasses are also used for less sophisticated roofing. But the latter, more frequently than the former calls for maintenance from the effects of the tropical rains, at least twice every year.

Modular materials such as bricks, adobe, and concrete blocks are less frequently applied in this building system. There exists stones

on the hills, but lack of refined technological tools for obtaining these have made stone houses very uncommon.

This limited availability of building materials and technological know-how imposed a constraint on the types of existing traditional constructions. Walls are relatively thick to provide sufficient strength for the roofing. Multiple story houses are very rare. Most of the dwellings above two stories have very narrow rooms.

Houses constructed through traditional means made use of self-help and assistance from friends and neighbors, using inexpensive building materials which were more often collected from different sources than purchased. Periods of construction for a four-room house would generally range from two to ten weeks, with four men fully or partially involved in the building works. The techniques employed did not necessarily require the aid of skilled construction workers.

The cost of such a dwelling unit ranges from £100 to £200 (U.S. \$ 250 to \$ 500) estimated in 1965.

The walls of such houses are often decorated in modelled relief or with mural designs. Besides murals, patterned ornaments cut out from clay are used.

The life of such traditionally constructed houses was between ten and fifteen years, with need for maintenance arising during the later five years. The short life of this housing type was not disadvantageous to most of the seasonal migrants to the town, since they went back to the villages anyway, after a few years in the town, and often preferred

to leave the houses unmaintained during the raining seasons as they were absent then, cultivating their farms in their villages¹⁾.

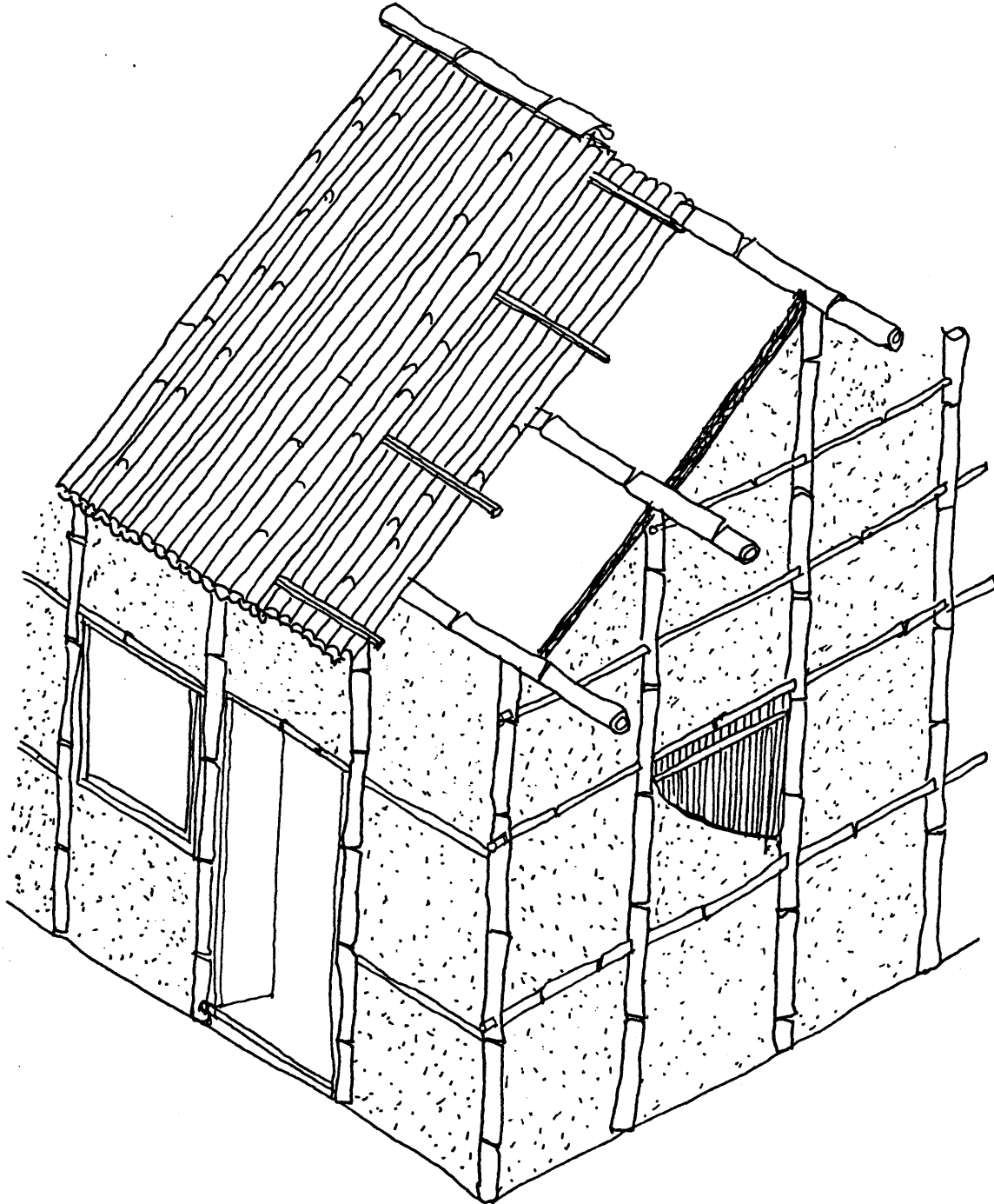

1) Illustration Traditional Type Dwelling

BAMBOO STRUCTURAL SYSTEM

C H A P T E R 3

EVALUATIONS

The previous section provided a general description of the past and existing housing conditions. The natural geographic forces coupled with what was obtainable in the form of resources, gave rise to certain housing problems. This section evaluates some basic notions of housing concepts in this community and discusses some aspects (habits and values employed in decision processes) which will be considered in the proposal for a housing development scheme.

The founding of settlements, and the stages of evolution of these settlements (shown in Drawing 1, page 15) were events strongly related to natural amenities. Since the climate was relatively hot all the year round, advantages of micro-climate, such as the prevailing breezes and other site benefits, formed important criteria for the location of various communities at the incipient periods. During the pre-colonial era, the town (a cluster of dwelling groupings and villages), was compact in itself, and later growth and expansion of the town due to urbanization forces (at the colonial times), typified a patchwork of small compact areas connected to each other by strips of commercial land. This factor reflected the following aspects:

-- The unit of decision: the group expressed through clans or households as different from units employed by industrialized nations (the family).

-- The extended family household living pattern, illustrated in the concept of the 'compound' type dwelling houses. The compound sought and aided in many ways to unite and provide adequate facilities for all the members interacting in the enclosure. It was either walled or fenced all around to ward off intruders. Thus privacy and security of persons and possessions were maintained.

-- The low level of technology was illustrated in the transportation modes, the high premium placed on urban farmland, and the natural climatic influences. The pedestrian mode and the use of humans for transportation of goods are very common even today. This has necessitated the location of essential services of a community within easy pedestrian commuting distances.

With the developing economy and the formation of upper classes, demand and facilities of the buildings in the inner city became less appropriate to the tastes and resources of the more affluent, in the face of modern technology. The central city was then available to the lower income sectors who had either migrated from the rural areas or remigrated from other slum areas of the town. In recent years due to the increase in the migration of low-income groups, the gray areas of the central town have spread very rapidly. As demand for housing in the urban area exceeded the cheapest available units, the surplus was found spilling onto the nearest spaces. Shanty towns and squatter areas started forming on the periphery¹⁾. The upper income groups and the very low-

1) Drawing 1, page 15.

income groups were found competing for settlement in these areas. The result thus produced was an alternating ring of suburbs and gray areas. Nevertheless, it was apparent from the landuse pattern which group occupied what area.

The private sector (High and Middle classes), a very small percentage of the overall population, sought after better living environments than the old central town where initial settlement started. They continued to suburbanize as factors of greater mobility, rising income and changes in tastes of cultural progress continued to operate to their advantage. The rings formed by this group remained relatively small. Although this was the general case, there still existed pockets of high income settlements in the central town, for the few with a taste of in-town living.

The popular sector (lower income) which could not afford the cost of central town living standards, moved into unwanted areas of land, or into less-developed areas, which were often in poor terrain, subject to flood, or otherwise less suitable for habitation. The developments thus formed by them were temporary and opportunistic in outlook. In another sense, the rings formed by these groups were rural villages under urban conditions.

Groups distinguished in terms of their geographic and cultural origins, and in terms of clannish relationship, settled in various district areas. In these communities, even today, they lead a semi-subsistence, part-cash-part-barter mode of life, that in some cases

include semi-urban farming, and the rearing of livestock to augment their incomes. They depend on their neighbors for information, credit, aid, and the acculturation of their children. As immigration generally exceeds departure in these areas of the city, it is generally difficult to estimate the percentage of dwellers in these areas who eventually became successful or fail, and who go back to their rural villages or emigrate to other areas.

For these very low income households, urban living creates closer friendship ties. The status of the individual becomes through personal acquaintance, highly recognizable. The more successful few among them have less need for the closer community of the 'urban villager', and consequently, finding the closed society a hinderance, move out, always leaving behind only the lowest income groups in these areas.

3.1 - Factors Contributing to Housing Problems

Only seven decades ago, most of the urban areas in Nigeria (including Onitsha), were still in their rural stages. As economic forces accelerated growth of these new urban centers, population increase, and immigration occurred at a rate very difficult to be provided for by the developing economy.

In certain cases, isolated projects, in the form of few instant housing were established. These projects on the whole had little or negative effects on the general condition of development, and in fact, either interfered with the urbanization processes or worsened the conditions.

Other instances where the government had imposed master plans, or finished housing plans, as could be applicable in industrialized countries, were fruitless in the face of the changing order of things. As the demand for housing far exceeded the government's own resources, housing problems caused by inadequacies due to overcrowding, similarly, were beyond the government's direct control.

As the existing patterns took the form of the initial rural community planning and layout, which did not provide much for future readjustments, increasing demand for the urban land resulted in the construction of windowless rooms, etc; on the resubdivided plots.

Very much unlike most other developed countries, only two choices existed: to do nothing at all, or to recognize the people's will and influence their actions by smoothing the paths they should follow through careful planning to discourage detrimental alternatives.

3.2 - Aspects of Housing Inherent from Existing Conditions

Several aspects feature very prominently in the housing pattern of the community described which ought to be considered in any proposal for future low-cost, low-income development scheme. These are, essentially, the unit of decision for housing, the habits of the communities, and the availability of resources.

The unit of decision is the group, reflected through the following:

--- The compound type dwelling houses.

--- The extended, or aggregate family types, which though on the decline are forces to be taken into account, the planning of which calls for future disaggregation in the face of upward mobility.

--- The courtyard which has emerged as a dominant spatial element among the communities. Apart from its recreational role, its other functions are vital to the people's living pattern:

-- A nucleus of domestic activities. Together with the adjoining verandah, this enclosure serves for housework.

-- A play area for children. Dwelling units with interlocking courtyards of various sizes constitute physical controls to confine children according to their age groups, and within the range of parental supervision.

-- A place slept in during the late evening hours, when the roofs and walls are re-radiating their absorbed heat from the hot tropical days. As an improvised space, the courtyards and the adjacent verandah provide shelter for new migrants to the city, who other-

wise would suffer from lack of housing, thus taking care of potential squatters.

-- In some cases, a location for a small industry, to augment the household income in the urban environment. Located in the courtyards are small industries, such as weaving looms, woodworking shops, processing of palm produce, and seed grains.

Aspects about habits of the low-income households in this community are illustrated in the use of dwelling units spaces and the location of various domestic utilities. The living areas serve in many cases as sleeping places and also as places for transacting small commercial business (such as retailing of groceries). Owing to lack of sewers, and pipe drains, kitchens and latrines were usually located at the rear of the lot.

Finally, the availability of local resources imposed a major constraint on the types of dwelling units. The building components were of cheap materials, and these gave rise to a lot of physical hazards - fire, termites, etc.

C H A P T E R 4

PROPOSALS

In the previous sections, a house was observed not only as an enclosure which shelters a group of persons, but also, as a place for light industrial and commercial activities, depending on the socio-economic condition of the household interacting in that enclosure. This broad usage of the house is very much like that described in the United Nations "Ad Hoc Committee on Housing" in its report of Feb. 1962. "... from the family's perspective, ...housing is not a 'shelter' or 'household facilities' alone, but comprises a number of services, and utilities which link the individual and his family to the community."

One argues, therefore, that in this community, a society which cannot mobilize nor possess the necessary resources to build completely modern, minimum standard units for all who need them, why planning for housing should aim at providing the families or households unit with what they can afford under their present condition.

It will be desirable if such low-income households are allowed to occupy plots of land as soon as the minimum possession are acquired. A starting point could be in a any sort of manageable shelter, leading gradually to improvement in living conditions. This will make such households far more independent at a much earlier stage of their occupancy on a site.

Moreover, since credit loans for building are very scarce for the low-income groups in Nigeria as a whole, and similarly in most other developing countries, the cost of instantly and fully completed dwelling units, or even semi-finished housing will be very high.

Even with the government providing a heavy subsidy on the interest rates of instant housing loans, the cost of such a scheme will all the same impose a long amortization on the beneficiaries. And with such long-term mortgage periods (usually about twenty years), the occupants security to tenure will normally be reduced. One wonders how many low-income family households in the situation described, or in other similar cases, probably having lived for many years in rented rooms, and having needed a house of their own, will accept the long-term debt through financed housing if the very security being sought after is thus threatened.

4.1 - Proposal for Progressive (Incremental) Development of Low-Cost Housing for the Low-Income Groups

Housing which develops through incremental stages is viewed as an ideal pattern for the low-income groups in Onitsha, Nigeria. The owner-occupier housing provides many resources in the form of initiative skills, and time. Money spent on materials and on hiring labor could be minimized through the time, patience, and bargaining skills of most low-income households, together with the help likely to be obtained through their workmates, friends, and relatives.

In addition, housing development through this proposed process strengthens family relationships within the aggregate family households, and this in turn may act as a tonic in social development in the community as a whole.

4.1.1 - Disadvantages of Instant (Fully Built) Houses for Low-Income Groups

Instant development of a housing scheme often stagnates in various ways, the community being served. Households or family groups are often chosen from particular socio-economic segments of the society. In most cases, the lowest income groups which need the subsidy most would have been left out, for the reason that their financial asserts are usually their homes, most of them being unemployed or seasonally employed. And it would be reasoned to be practically impossible to recover housing capital from them when they are out jobs. This overriding point consolidates the argument for their automatic exclusion as recipients of instant housing units.

Since it is not intended to isolate the lower income sector or to limit their scope for interacting with the more privileged income segments, and since it is intended in this work to serve primarily the ends of the low-income (popular) groups of the community, it is reasoned that instant housing, or the imposition of a specific housing type through instant development, will limit the cause of the objectives sought after in this thesis.

A progressive housing development scheme eliminates the motives for socio-economic, or socio-political selection of groups. If the upper income groups feel inclined to join in the establishment of the proposed site, it will be perfectly in order. The more the interaction there is of various income groups, the more there is an opportunity for improvement for the very poor¹⁾.

1) Tanzania, East Africa, illustrates vividly the application and acceptance of such interaction, where the government adopted a policy of deliberate mixing of various income groups in its public housing scheme.

C H A P T E R 5

GUIDELINES FOR IMPLEMENTATION OF A
PROGRESSIVE HOUSING SCHEME

"The guidelines for design of the proposed progressive housing process can best be summarized as a consideration of the priorities between the basic functions of the dwelling environment in relation to the changing life-situations, and subsequently, the changing priorities between the physical components of the environment."¹⁾

The low-income sector in urbanizing areas similar to the case described in Nigeria, seeks, in an order of priority:

- Land tenure... through rights granted to recipients in the forms of occupation or acquisition, by lease or through permanent ownership.
- Community facilities... through investments in civic centers, schools, and other such services, by the government or public sector.
- Adequate dwellings... through implementation of land use controls, facilitated by building regulations, and zoning, as may be the case, coupled with adequate police power to ensure that phases of set standards and tenure regulations are met by both the occupants and the developer.
- And lastly, the introduction of household utilities to the built structures.

1) Turner, J. C., A New View of the Housing Deficit. Here Mr. Turner points out that priorities among low-income groups vary considerably according to different social situations. The very poor (below subsistence standards),

5.1 - Tenure

The classification of different types of holdings on land is designed to avoid mixed-level development on the proposed site. Various recipients of land may occupy subdivided plots in accordance to their resources, needs, and proposed usage of the assigned plots.

TYPE 1 (Rental)

The plots for rental are designed for the bottom segment (the very poor or marginal income groups), and for the transient semi-migrants to the town.

--- The former (very poor) may find it almost impossible to afford a large sum of money initially to purchase a plot in the developed site, but will be able to pay rent monthly for the usages of such rental plots.

--- The latter group, because their stay is transitory or undecided, may be unwilling to pay large sums for a piece of land they probably may be needing for only one or two years before deciding to go back to their initial point of migration to the site.

The plot designed for rental will be very small (four meter in width, and six to eight meters in depth). The prices of such plots will be relatively less per square meter than other types of plots on the site, the reason being that the rental plots will form the majority of the initial

and the transients in the community (as also pointed out in earlier sections) do not have a high priority for land ownership. They would be satisfied with obtaining a renewable security to the land, and will feel free to leave at any time desirable to them.

subdivided settlement, at the time water, electricity and sewers are still inadequately provided. And also, because these income group types may not be able to afford taxes for the paving of streets and side-walks as long as they keep renting on the site.

Constraints on building standards will specify that rental plots can only have temporary structures on them. As a control for protection against fire, a concrete block wall was designed at intervals of four plots. The lease for renting plots to particular households may be renewable every year or half yearly.

It is projected that as factors of upward socio-economic mobility continue to operate (even at the present pace), that during the saturation period (about 10 to 15 years of initial settlement), all rental plots will have had to have been transformed to other tenure arrangements, or the government may then be in a position to provide other alternatives (public housing) to replace the existing shacks built by these household groups¹⁾.

TYPE 2 (Leasehold)

This arrangement is designed to meet the resources of the middle low-income household families. This group by description may be able to afford a permanent structure, but only after a period of occupancy on the plot. Their initial dwelling units may be of temporary construction. Their tenure arrangement may require them to put up permanent structures

1) Drawing 8, page 47.

before the expiration of the first lease term (say two years).

The plots designed for this group vary between seven and ten meters in width, and twenty to twenty-five meters in depth¹⁾.

TYPE 3 (Freehold)

This tenure arrangement is designed for the household groups at the top of the low-income sector²⁾. Plot sizes will vary between seven and ten meters in width, and twenty to thirty meters in depth, and the plots will be located along the major vehicular traffic routes.

The beneficiaries of such tenure arrangement will be required to put up permanent structures at the acquisition of title to the land³⁾.

1) Drawing 9, page 48.

2) Some of the family households in this segment may have annual incomes within the range of the market level (Chart 2, page 11).

3) Proposed minimum standards of permanent structure are shown in Drawings 10 through 14, page 52 through page 56.

5.2 - Landuse Pattern

Residential: The subdivision of residential plots was based on a grid pattern corresponding to room widths and to the maximum efficiency of plot depths. The minimum of one efficient room width plus a passageway formed the minimum plot width. A maximum of three room width was considered desirable for a low-income household, which was reasoned to be the limit for usage of one passageway or corridor.

The optimum depth of the plot was taken as one half the entire breadth of a block, which will allow for a service lane through the middle of the block. The minimum depth was considered as one quarter of block breadth, assuming that the occupants of such plots may not be able to afford household utilities (such as private water taps and sewers). This minimum plot depth allows for a minimum of two rooms depth or one room depth and a courtyard¹⁾.

Commercial: A strip of commercial along the existing trunk road will connect the local commercial areas. The initial and second stage development phases will allow for the usage of planned open spaces in the days as open market areas, and in the evenings as recreational areas, corresponding to the existing notions of the village squares. In future, these spaces will probably function as parking lots, and as play areas, at the saturation periods.

1) Appendix 1, page 66(Study of dwelling plot analysis system in Course 4.161, with supervision of Prof. H. Caminos, M.I.T., 1968).

Others: The planning of the major circulation route aims at providing an ideal residential layout for the site, and attempts to conduct all motor vehicles around the interior of the site without permitting high speeds. The intersections form "T" junctions, to eliminate as much as possible the usage of expensive traffic lights. The major circulation was designed to carry four lanes of traffic, in addition to a pedestrian lane on each side of the road¹⁾.

The location of schools, civic centers, parks and other community facilities was determined through a study of a normal walking distance grid pattern from all points on the site. The average of ten and six minutes walking time distance seemed a desirable optimum for school children going to school from their homes, and for adults going to the community centers.

1) Appendix 2, page 75 (Classification and specification of roads).

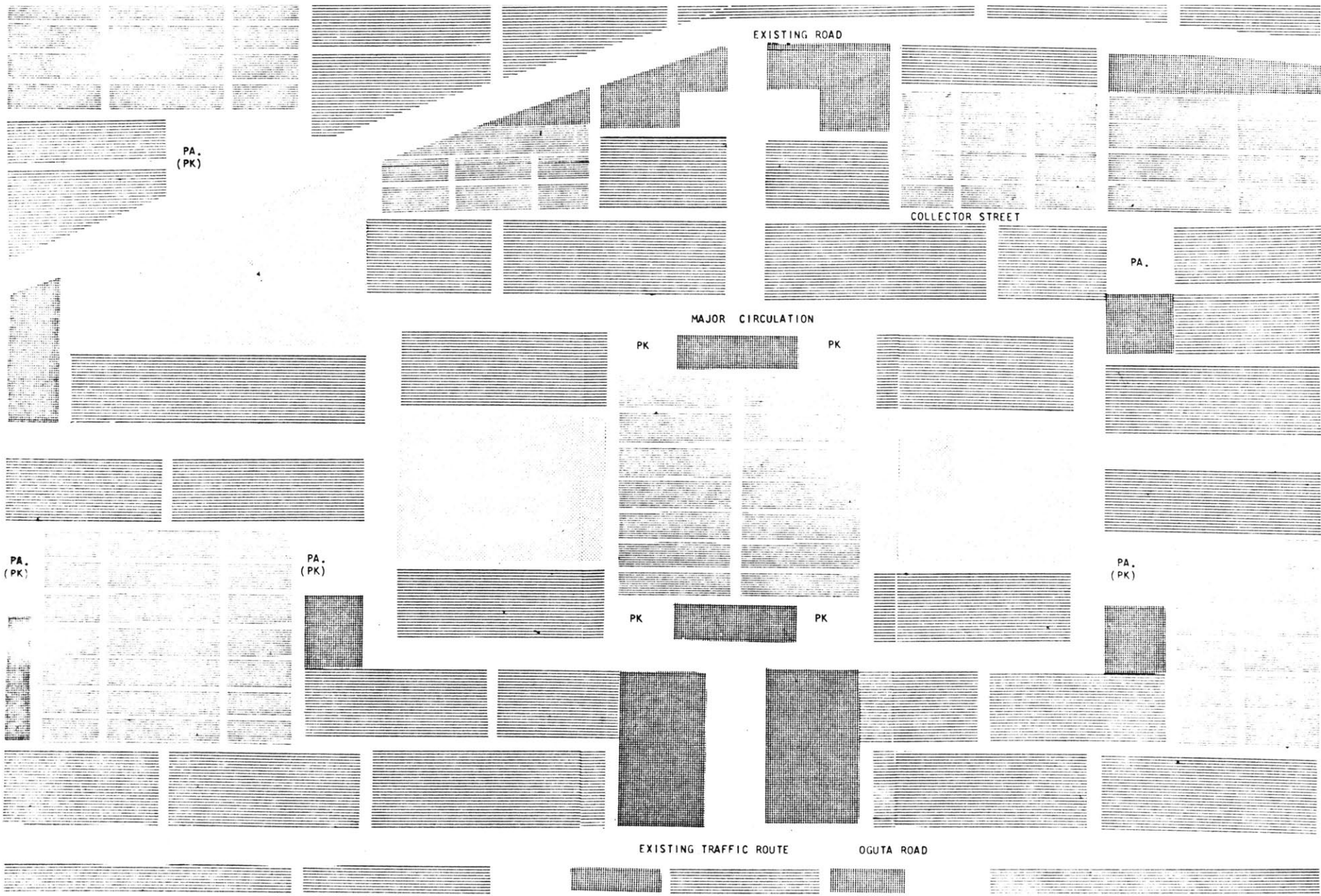

SITE PLAN (CONCEPT OF SUBDIVISION)

PA. PLAY AREA
 PK. PARKING

AREAS
 RESIDENTIAL (LEASE, FREEHOLD)
 RESIDENTIAL (RENTAL)
 COMMERCIAL
 INSTITUTIONAL

LOW-COST, LOW-INCOME HOUSING IN NIGERIA
 B.A. ARCH. THESIS 1970
 MASSACHUSETTS INSTITUTE OF TECHNOLOGY
 CHEKI ENWONWI

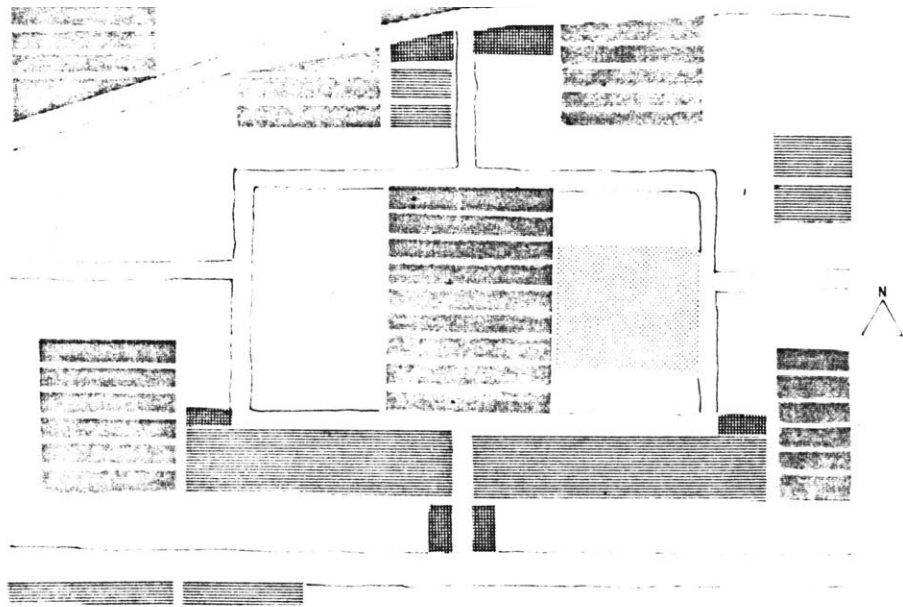

SITE PLAN FIRST STAGE DEVELOPMENT (INCIPIENT PERIOD) 5 YEARS

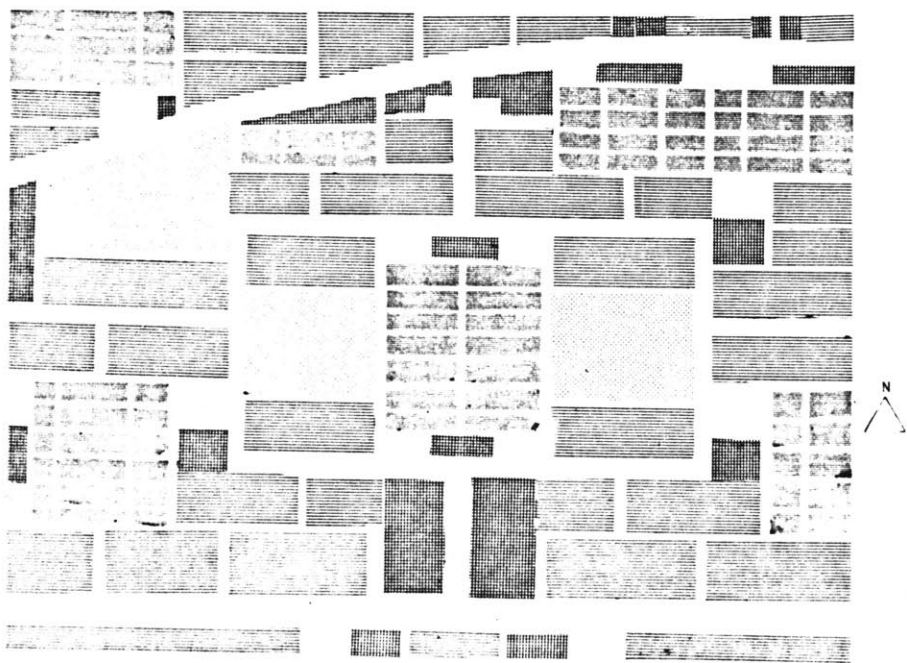

SITE PLAN: THIRD STAGE DEVELOPMENT (SATURATION PERIOD) 10 - 15 YEARS

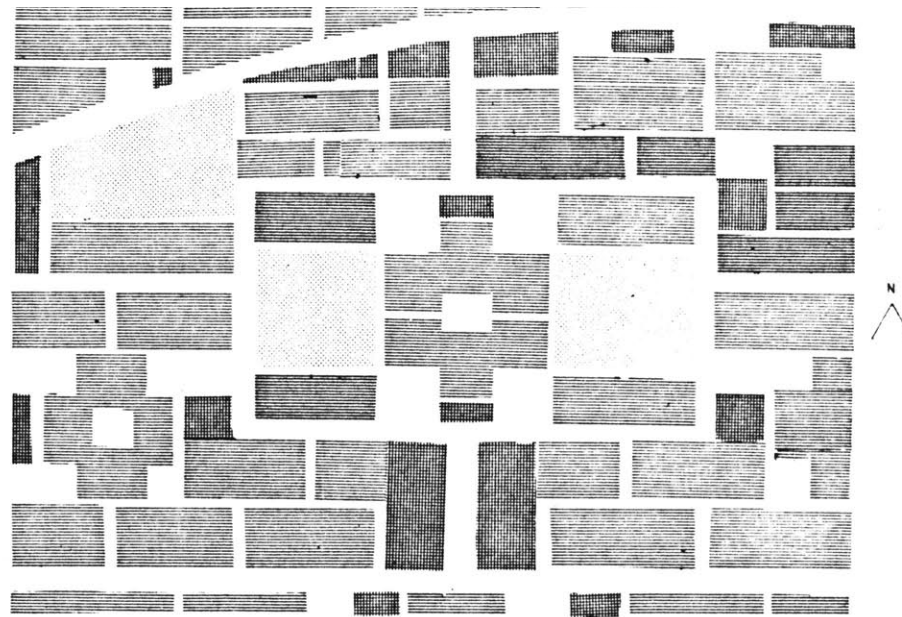





SITE PLAN: SATURATION PERIOD (RESUBDIVISION OF SITE)

0 50 100 200 METER

LANDUSE PATTERN

AREAS

-  RESIDENTIAL (LEASE AND FREEHOLD)
-  RESIDENTIAL (RENTAL)
-  INSTITUTIONAL
-  COMMERCIAL

TOTAL AREA OF SITE = 40 HA.

LANDUSE PATTERN: SATURATION PERIOD (15 YEARS)

AREAS	RATIOS IN %
RESIDENTIAL	60
COMMERCIAL	5%
INSTITUTIONAL (& PARKS)	10%
CIVIC CENTERS, & PLAY AREAS	5%
CIRCULATION	20%

LOW-COST, LOW-INCOME HOUSING IN NIGERIA. **8**

B. ARCH THESIS 1970
 MASSACHUSETTS INSTITUTE OF TECHNOLOGY
 CHIKE ENWONWU

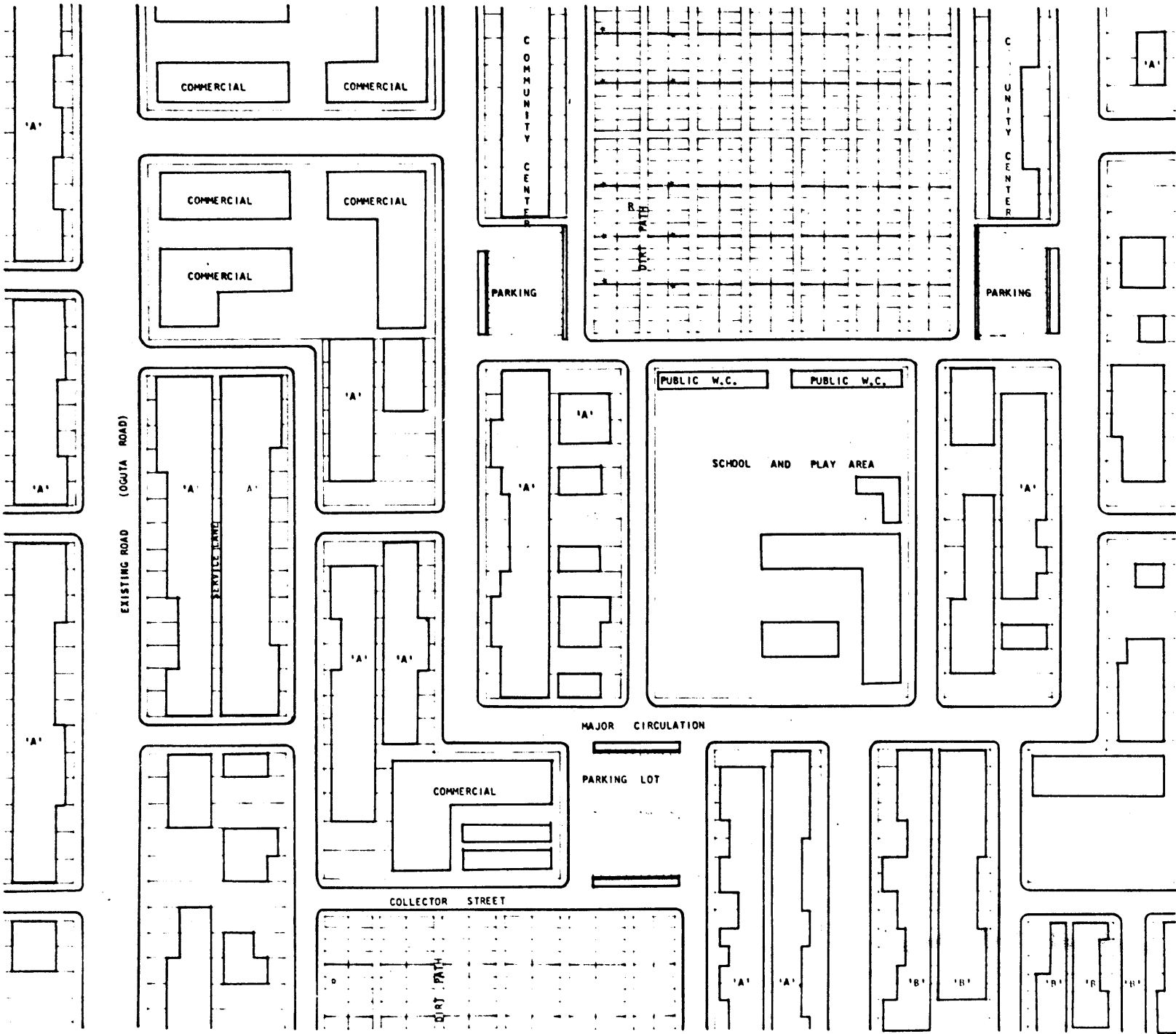

* CONCRETE BLOCK WALL (CONTROL FOR FIRE)
 DIRT PATH = 6 METER WIDTH

LOCALITY SEGMENT

A R E A S:	HECTARES	PERCENTAGE
PRIVATE OWNERSHIP		
DWELLING PLOTS	6.40	40.0%
COMMERCIAL	0.80	5.0%
PUBLIC OWNERSHIP		
RENTAL PLOTS	3.20	20.0%
COMMUNITY CENTERS, PLAY AREAS, SCHOOL	2.40	15%
CIRCULATION (STREETS, AND PATHS ETC.)	3.20	20%
TOTAL	16.00	100%

PROPOSED DENSITY (SATURATION PERIOD)

	NUMBER	HA.	N/HA.
DWELLING UNITS			
RENTAL PLOTS (SHACKS)			
FAMILIES			
PEOPLE			

ASSUMPTIONS

- AVERAGE OF SIX PERSONS PER FAMILY
- AVERAGE OF ONE FLOOR STRUCTURE
- AVERAGE OF SECOND PHASE DWELLING UNIT TYPES



5.3 - Dwelling Unit Types A and B

The foregoing sections of this thesis describe the existing conditions in Onitsha. The evaluations of these conditions, coupled with what is desirable to achieve with the available resources, impose many constraints on the design of the dwelling unit types. In order to meet these demands, the design must reflect the following:

--- Simplicity of plans, and structural components, that can at the least be easily understood and executed by the unskilled or semi-skilled, unlettered beneficiaries of the proposed housing, through self-help means or the use of a small contractor.

--- Adaptability and flexibility of units to fit various arrangements on the designed plots (allowing in some cases, for two or more plots to be used commonly by a large extended family household type at one time, and at the same time permitting for disaggregation of these dwelling units plots at future dates)¹⁾.

5.3.1 - Phases of Progressive Development in Construction of Dwelling Units Minimum Standards

As guidelines for the incremental attainment of the proposed residential environment, standards for the various phases of the construction process were established.

1) Drawing 12, page 54. Type 'B' Dwelling Unit.

PHASE 1

This phase illustrates the minimum demands to be met by beneficiaries of tenure types One and Two (lease and freehold), at the initial settlement periods. Temporary structures could be built at the front of the plot, while construction of the permanent units are in process at the rear of the plot¹⁾.

PHASE 2

This phase illustrates the requirement of dwelling units standards before qualifying to receive private household utilities (water and sewers). Specifically, it is demanded that units acceptable to this standard must have kitchens and bathrooms.

PHASE 3

Completion stage of dwelling units ground floors. All units built to this minimum standard requirements must have at least one side open to either a courtyard or to the street, to permit for direct ventilation²⁾.

1) Drawings 10 and 12, pages 52,54. Types 'A' and 'B', Dwelling Units.

2) Drawings 10, 11, 12, 13, and 14, page 52 through page 56.

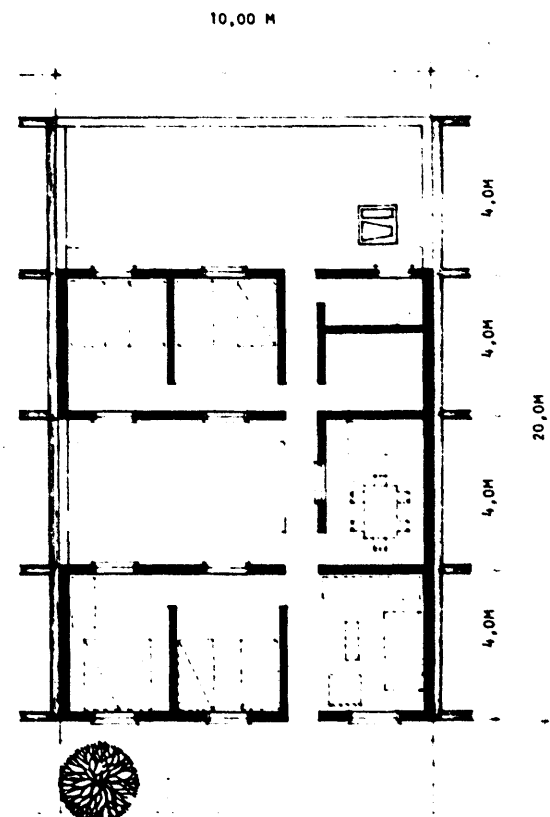
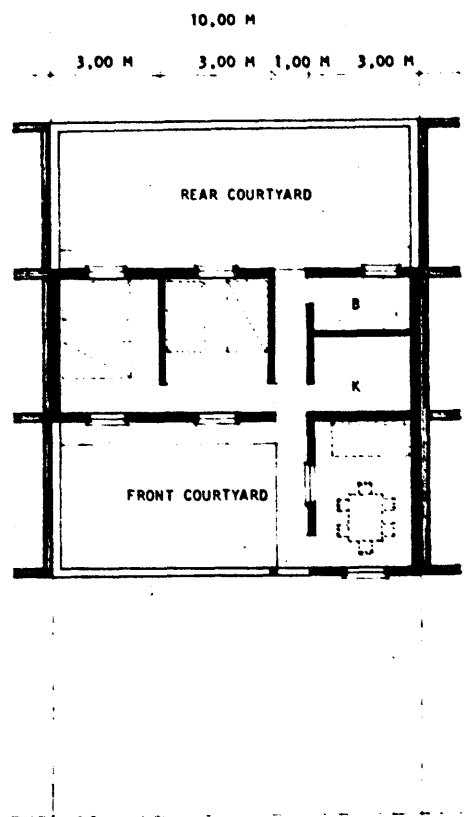
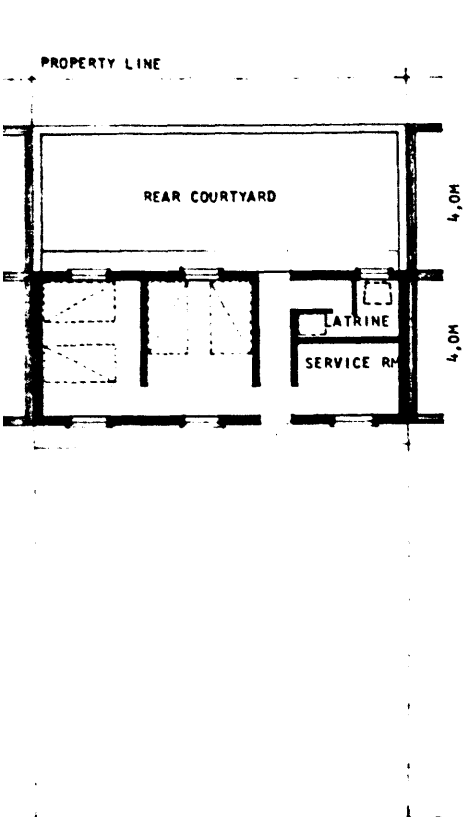

PHASE ONE: REQUIREMENT FOR TENURE TYPES 1, & 11 (MIN. STD.)
 TWO ROOMS, ONE SERVICE ROOM.
 COOKING (POSSIBLE OUT DOORS)
 NO SEWERS (LATRINES)
 STRUCTURE: CONCRETE BLOCK WALLS,
 CONCRETE SLAB ROOFING
 ONE FAMILY, SIX PERSONS

PHASE TWO: REQUIREMENT BEFORE INSTALLATION OF SEWERS
 TWO ROOMS, LIVING/DINING,
 KITCHEN
 BATH, AND W.C. (SEWER, AND WATER TO DWELLING UNITS)
 ONE FAMILY, SIX TO EIGHT PERSONS

PHASE THREE: COMPLETION STAGE
 FOUR BEDROOMS, LIVING, DINING
 KITCHEN, BATH AND W.C.
 EXTENDED FAMILY ABOUT 10 PERSONS.

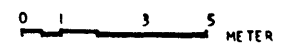

DWELLING UNIT TYPE 'A'
 SHOWING THREE PHASES OF CONSTRUCTION

LOW-COST LOW-INCOME HOUSING IN NIGERIA
 B.A.R.C.H. THESIS 1970
 MASSACHUSETTS INSTITUTE OF TECHNOLOGY
 CHIKE ENNONWU.

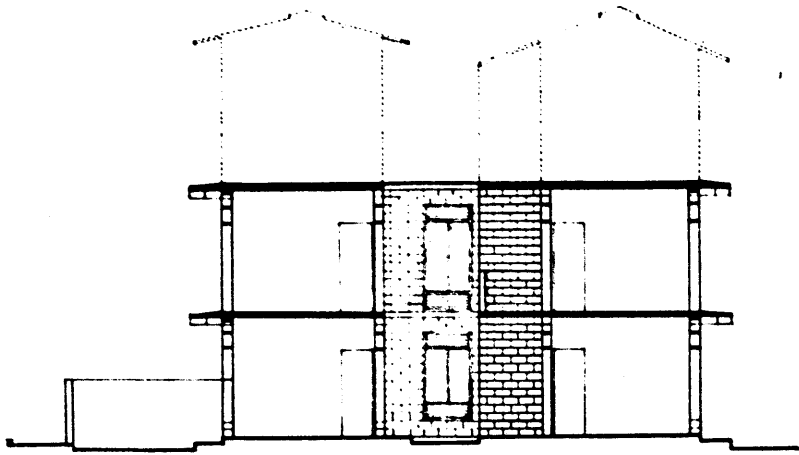

SECTION AT A-A

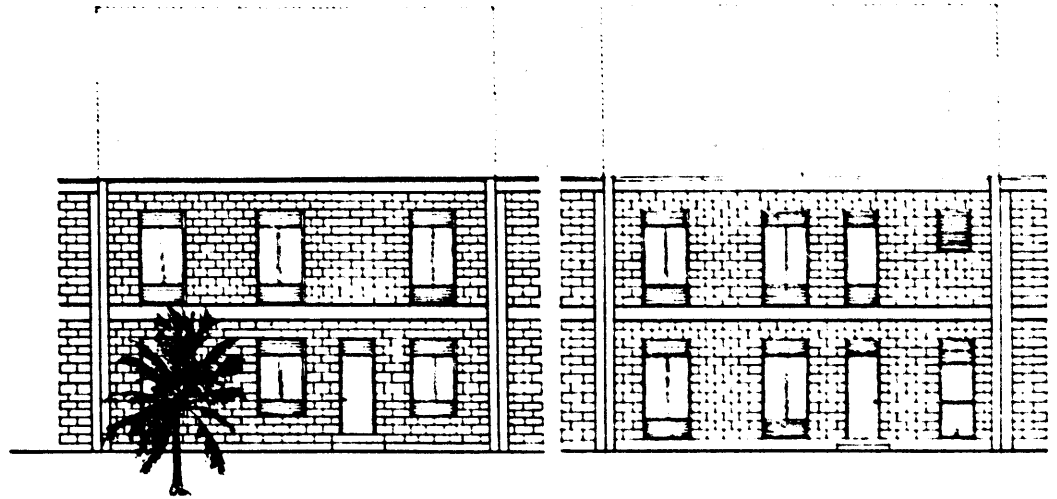

FRONT ELEVATION

REAR ELEVATION.

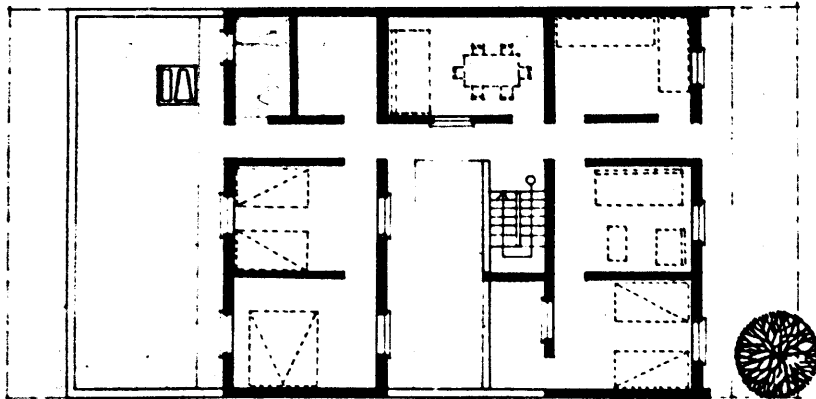

GROUND FLOOR PLAN

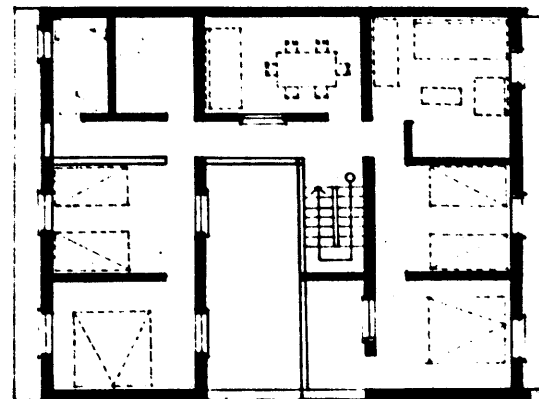

TYPICAL FLOOR

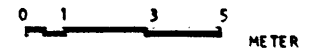

DWELLING UNIT TYPE 'A'
(FLOOR PLANS, ELEVATIONS, AND SECTION)

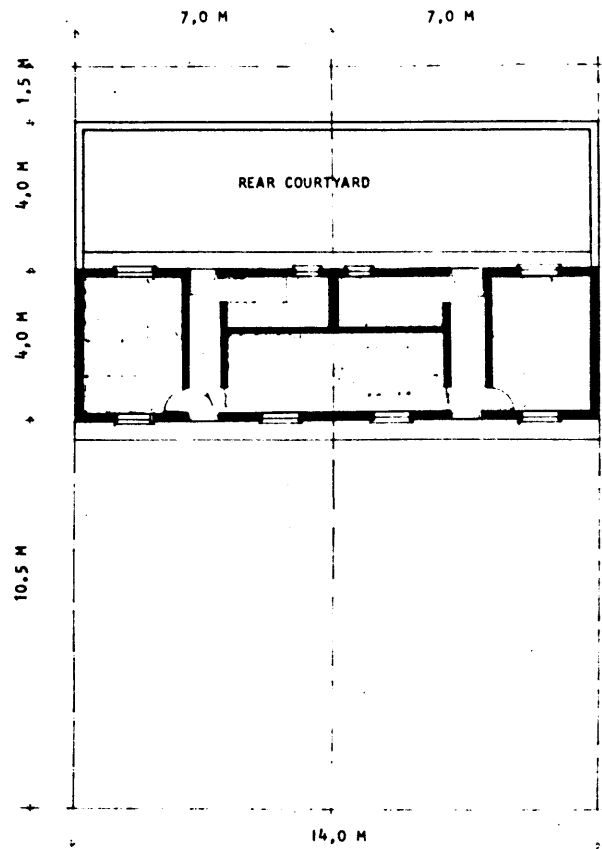
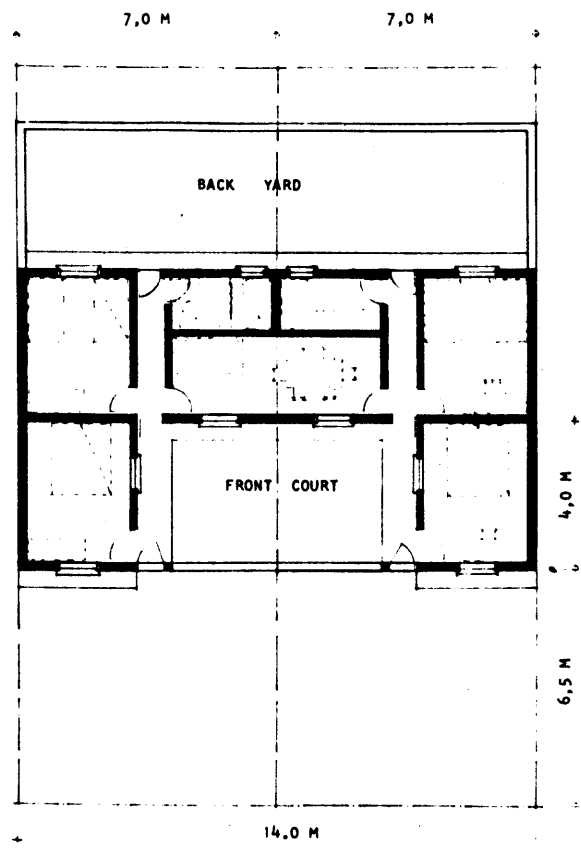
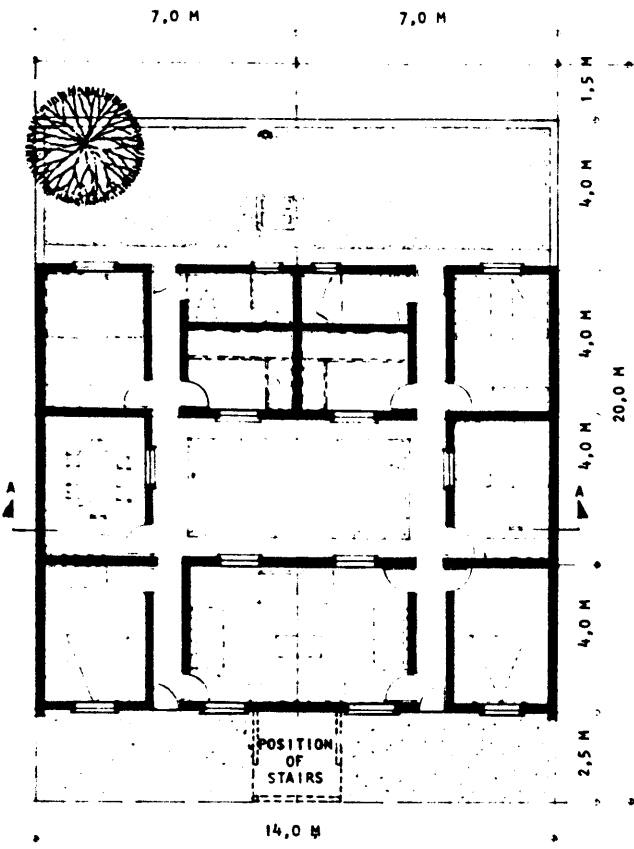

PHASE THREE: COMPLETION STAGE.

SIX BEDROOMS, LIVING DINING, TWO KITCHENS,

TWO BATHS, TWO W.C.'S

EXTENDED FAMILY NUMBER: 12 TO 14

PROVISION FOR DISAGGREGATION INTO TWO HOUSEHOLD TYPES. (= PARTITION) WALL

PHASE TWO: (REQUIREMENT BEFORE INSTALLATION OF WATER, AND SEWAGE).

FOUR BEDROOMS, LIVING/DINING, KITCHEN, BATH, & W.C.

EXTENDED FAMILY NUMBER: ABOUT 10

PHASE ONE: (REQUIREMENT FOR TENURE TYPES 1 & 11

TWO ROOMS, LIVING/DINING, KITCHEN, AND LATRINE

STRUCTURE: CONCRETE BLOCKS BEARING WALLS,
CONCRETE SLAB ROOFING

EXTENDED FAMILY TYPE DWELLING SIX TO EIGHT PERSONS



DWELLING UNIT TYPE 'B' (COMBINED PLOT TYPE)

FLANS SHOWING PHASES OF CONSTRUCTION, ELEVATION AND SECTION (FIRST FLOOR)

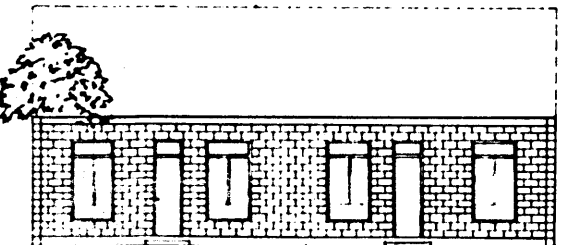

ELEVATION

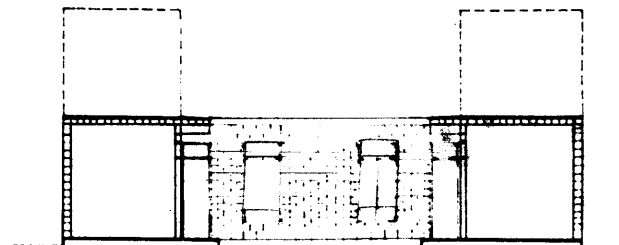

SECTION AT A-A

LOW-COST, LOW-INCOME HOUSING IN NIGERIA.

12

B. ARCH THESIS 1970

MASSACHUSETTS INSTITUTE OF TECHNOLOGY

CHIKE ENWONWU

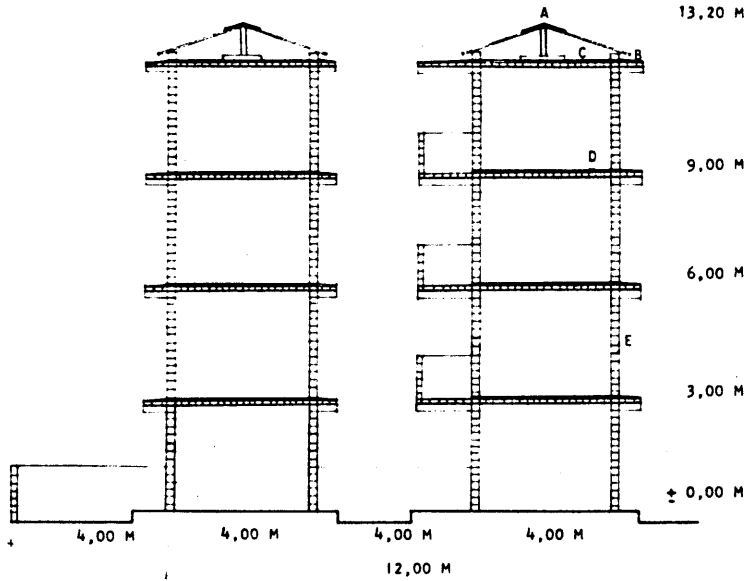

SECTION

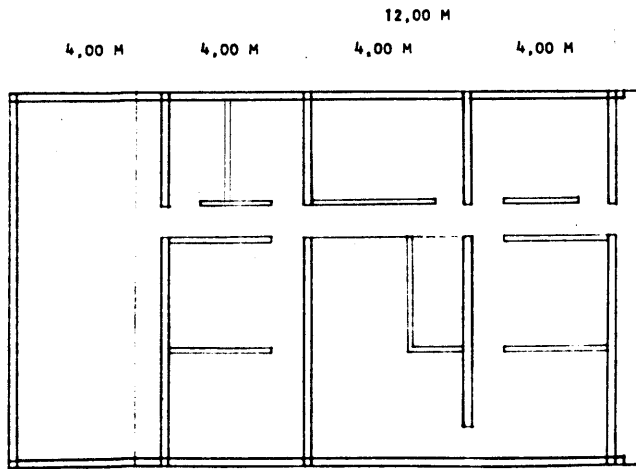

GROUND FLOOR PLAN

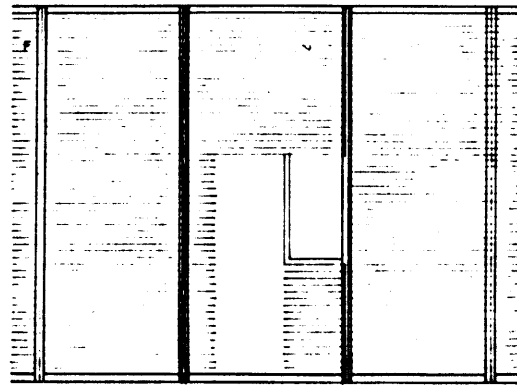

TYPICAL (UPPER FLOOR) PLAN.

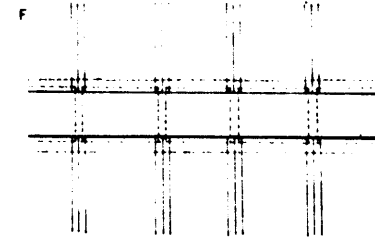
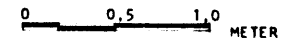
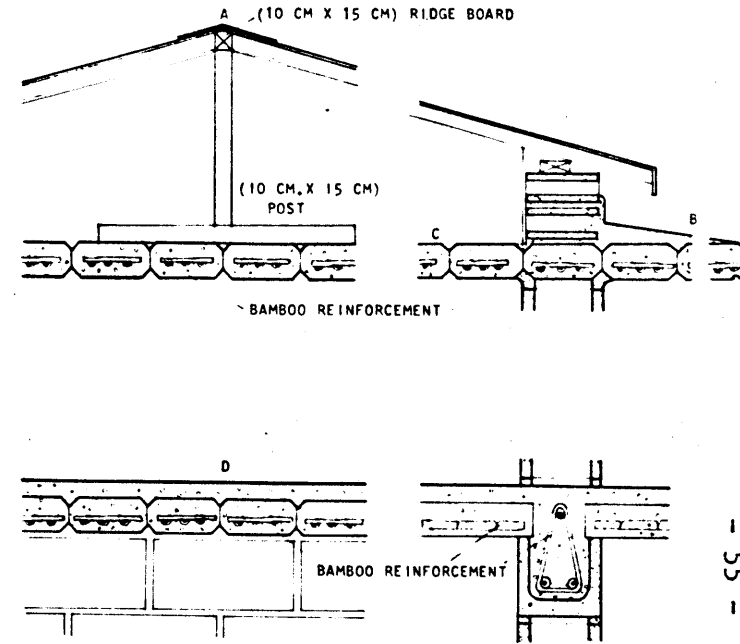

STRUCTURAL: DWELLING UNIT TYPE 'A'
PLANS, SECTIONS, (DETAIL)

LOW-COST, LOW-INCOME HOUSING IN NIGERIA
B. ARCH THESIS 1970.
MASSACHUSETTS INSTITUTE OF TECHNOLOGY
CHIKE ENWONWU.

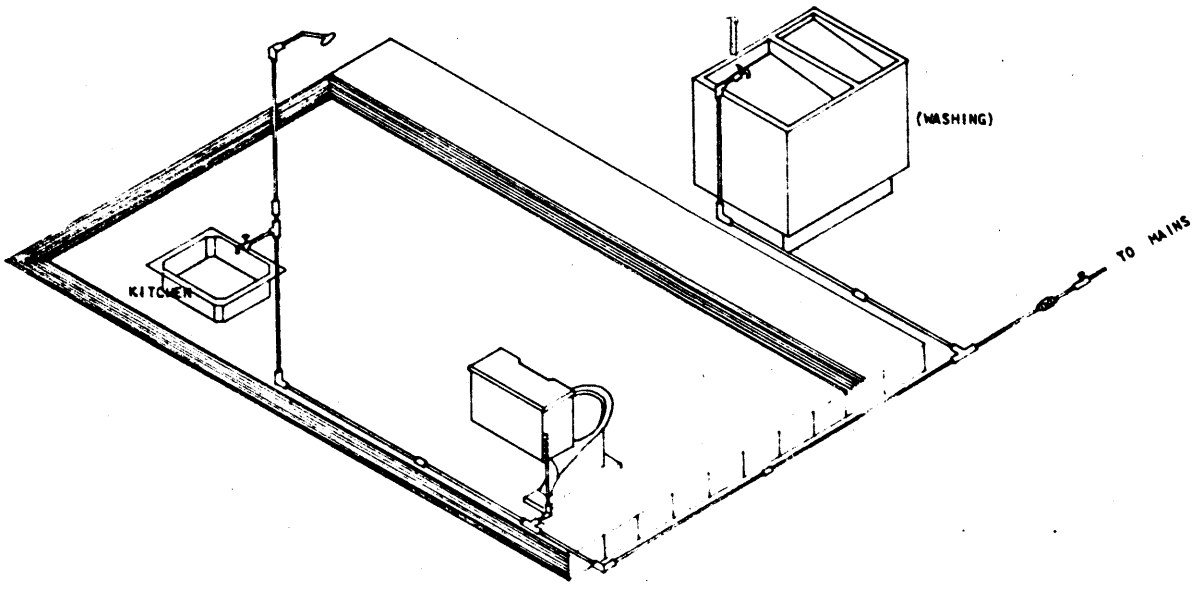

S C H E M A T I C (WATER SUPPLY) IN ISOMETRIC
(ESSENTIAL FOR HOUSEHOLD)

SCALE 1:20 METER.

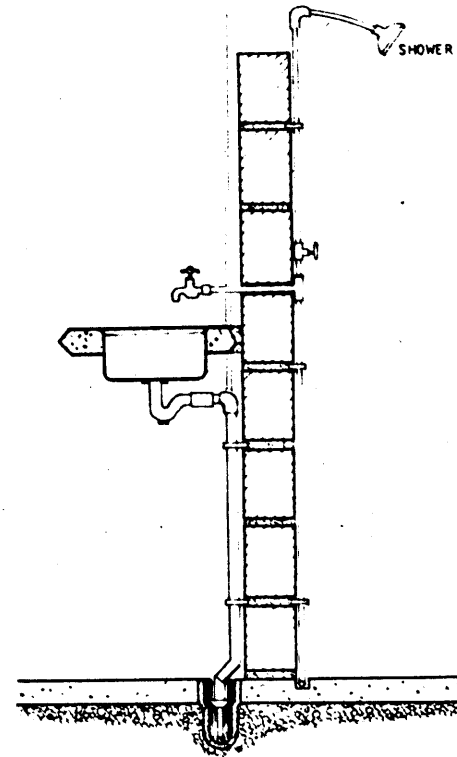

S E C T I O N (KITCHEN & BATH), DOMESTIC WATER AND DRAIN
SCALE 1 : 10 METER

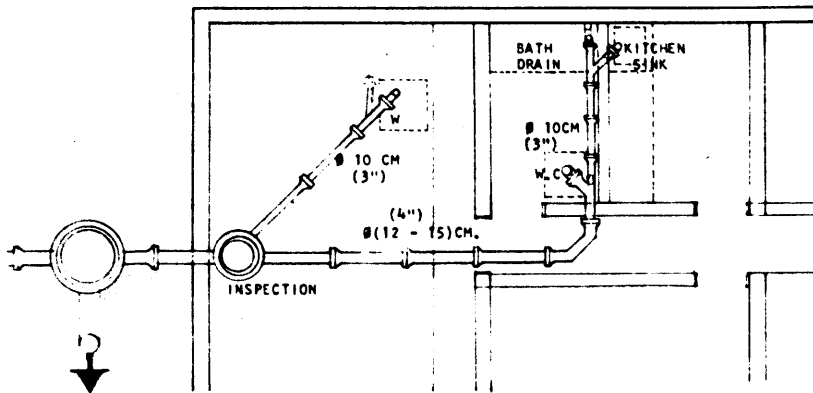

P L A N (WASTE DRAINAGE PIPES)

SCALE 1:50 METER.

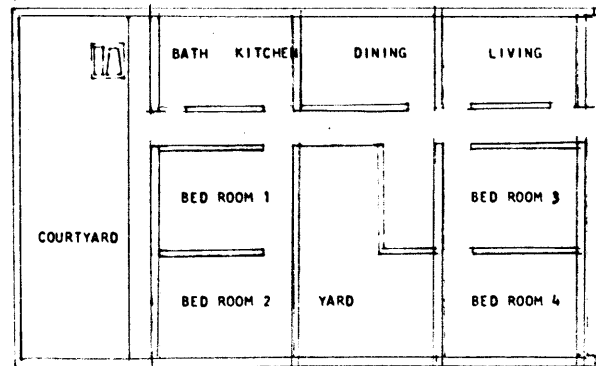

F L O O R P L A N (DWELLING UNIT TYPE 'A')

SCALE 1 : 100 METER.

UTILITIES: DWELLING UNIT TYPE 'A'
WATER, AND SEWAGE DISPOSAL (PLANS & SECTIONS)
LOW-COST, LOW-INCOME HOUSING IN NIGERIA
MARCH THESIS 1970
MASSACHUSETTS INSTITUTE OF TECHNOLOGY
CHIKE ENWONWI

C H A P T E R 6

EVALUATION OF DEVELOPMENT

Based on the socio-economic situations, and the dwelling environment patterns, the design of progressive housing scheme is evaluated in this section as an "equifinal" response to the low-income beneficiaries designed for in this thesis.

On the assumption that the development of this scheme will proceed as projected through the proposed stages, the following figures estimate the result of the development.

6.1 - Landuse Pattern (completion Stage)

	<u>Area in hectares</u>	<u>Ratio in %</u>
Total area of site	40	100%
Residential plots (rental, lease, freehold)	24	60%
Community centers (schools, parks, etc.) ..	6	15%
Commercial (including open-air markets) ...	2	5%
Circulation (streets, parking)	8	20%

The first stage is estimated to phase out by the 5th year of development, and the second stage, between five and ten years of the incipient period. The saturation (third) stage, will occur at about ten years after the initial development was started.

The estimated (projected) density per hectares through the stages:

- Stage One 60 persons/hectares.
- Stage Two 120 persons/hectares.
- Stage Three 150 persons/hectares.

(on the assumption that six persons will constitute a family, and that all dwellings are one story).

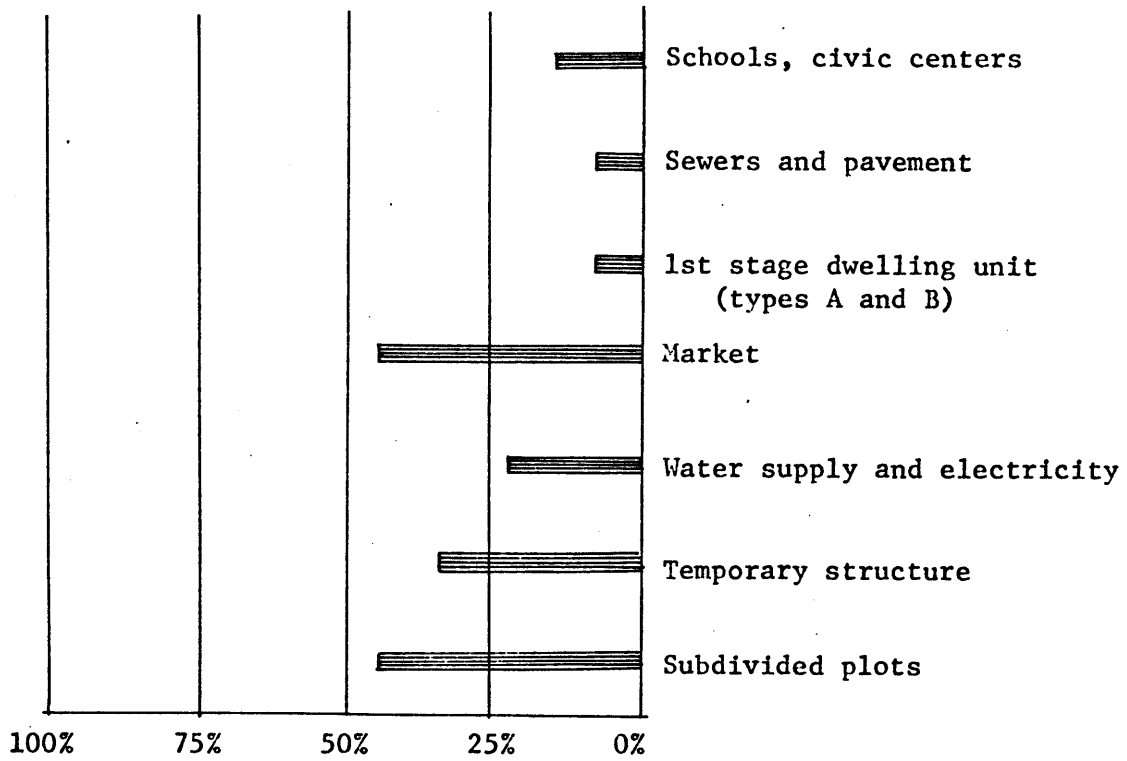

6.1.1 - Assumption (proposed development) Stage 1 - Incipient period

The projection of development in the initial period assumes that only about 40% of the site will have been subdivided for occupancy. About 85% of the plots on the subdivided piece of land will belong to type one tenure arrangement (rental). The remaining 15%, possessing leasehold and freehold tenure arrangements, will have started putting up permanent structures on the plots (constituting about 5% of the entire site). Sewers and pavements will be provided to areas on the site that possess freehold and leasehold tenure, while the rental households may use the publicly provided sewage, or the 'night soil' pick-up scheme.

It is also projected that schools will be available to all families leasing or freeholding acquired plots. About 30% to 40% of the rental areas may be using school facilities (since a large number of such households may belong to the transient groups, in which case they are single-person household; or where there are children in the families, education may be economically difficult.

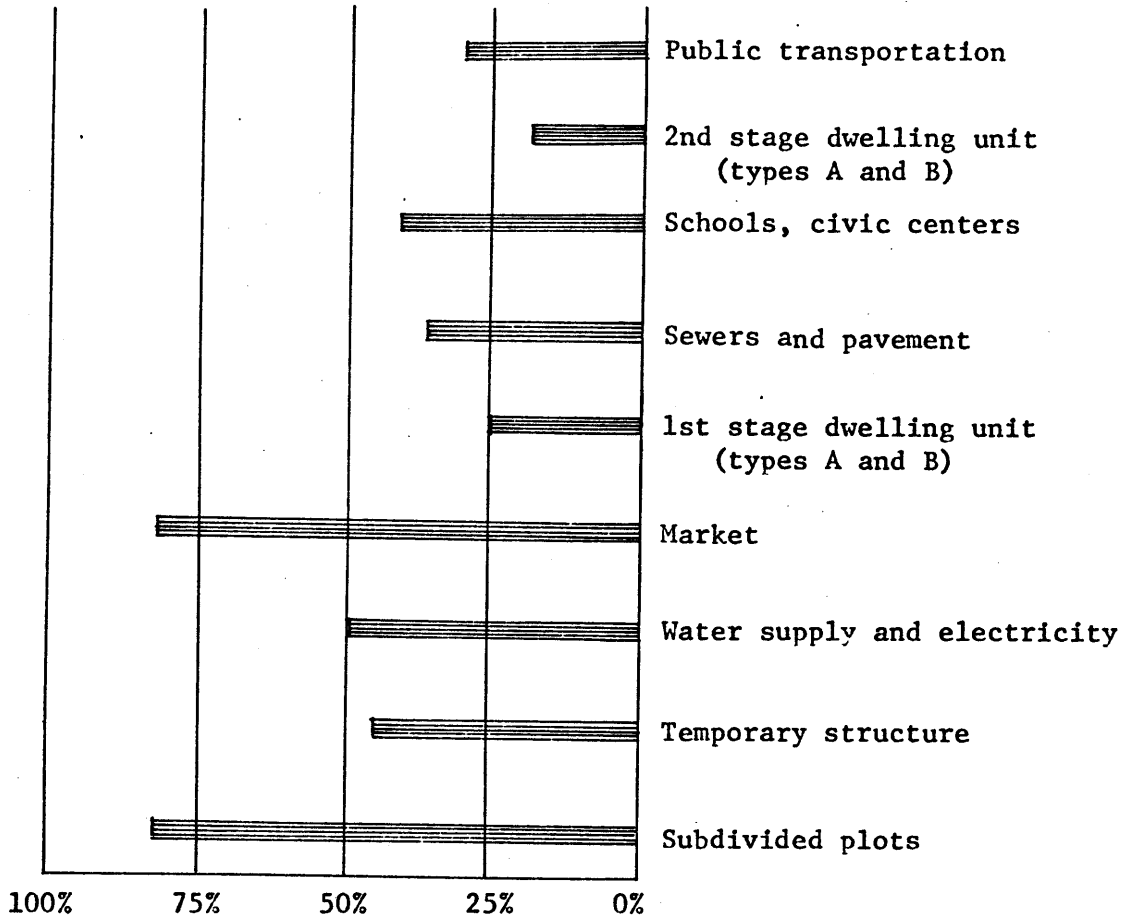

6.1.2 - Assumption (proposed development) Stage 2

As the area of subdivided plots increases, the number of rental plots similarly increases and so does the number of leases, and of free holders of title to the land.

Community services, on the other hand, expand to accommodate the rising needs, and so does commercial land use.

A new dimension is added through the expansion of paved areas. With the rising population, public transportation to the central business district projects a passenger load of about 30% of the site dwellers.

A this stage, it is projected that about 25% of dwellers on the site will have started the second phase of their structural units.

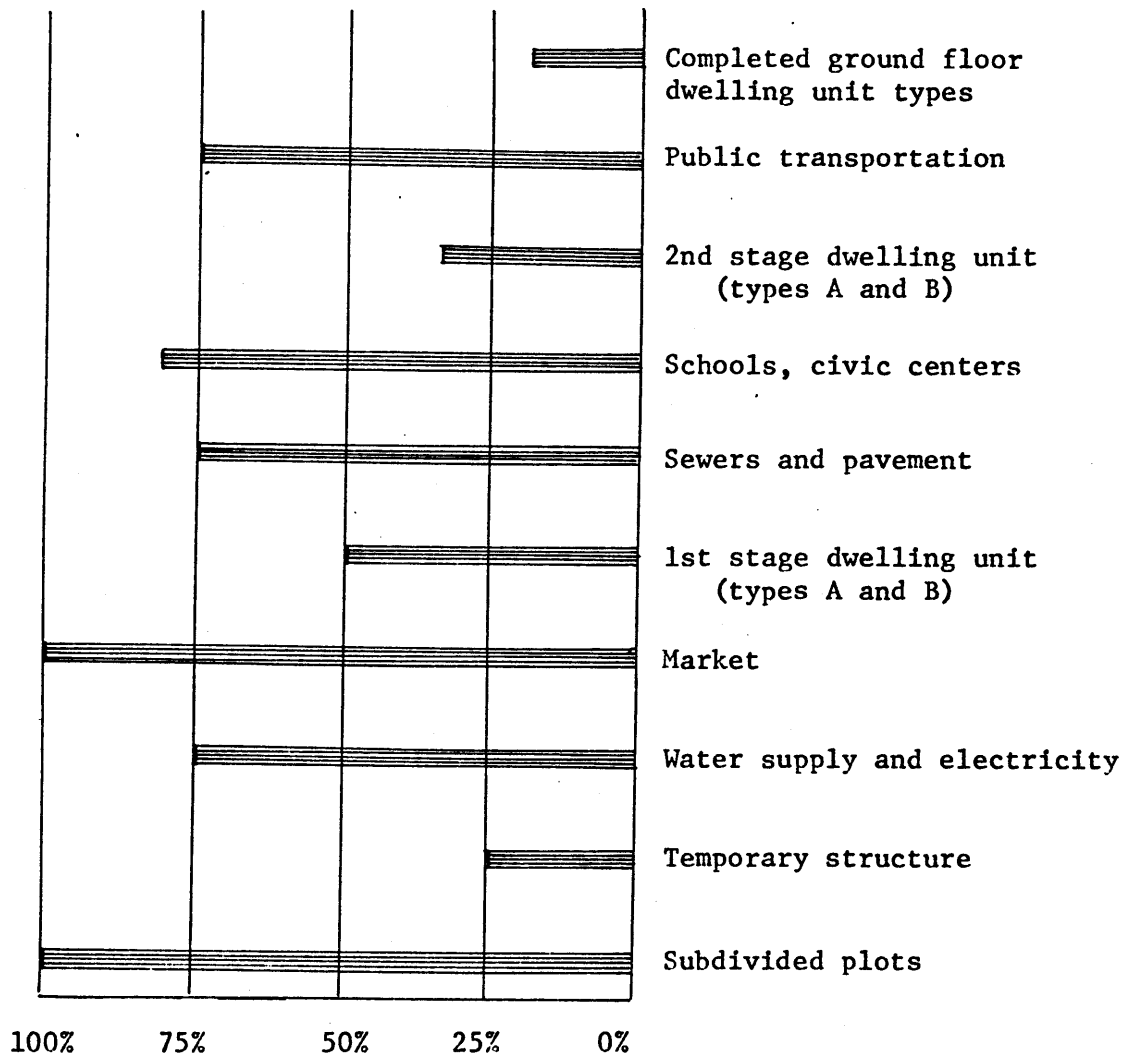

6.1.3 - Assumption (proposed development) Stage 3 - Completing period

At the saturation period when the site will have been completely subdivided, it is projected that the number of rental plots will have decreased, or will have been transformed into other land title forms. Most family households will have completed their total ground floor, and probably will have started adding other floors on their structures.

Services and utilities will similarly have extended in accordance to demand and required standards.

All vehicular traffic routes will have been paved.

6.2 - Alternative Routes of Proposed Development

The proposed development pattern discussed in 6.1 responds to the future mobility of the existing conditions observed in the early chapters of this work. If the population growth, the migratory elements, and the economic development trends continue to operate to the advantage of the predictions, the thesis so far, answers all the predictable questions of the future mobility.

If, on the other hand, urbanization proceeds in a different pattern, the scope of the design provides flexibility for replanning to accommodate the new trends. Alternative routes of future mobility are discussed in this section, as a support for the "equifinality" and completeness of the thesis.

The population trend is illustrated in figure 2, as taking a different pattern as of the existing projection.

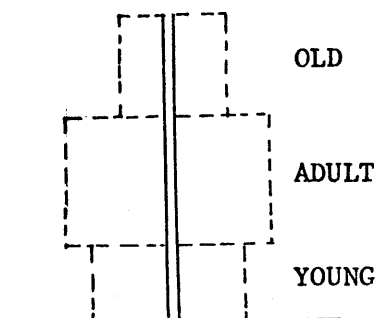

Fig. 1

AGE-SEX DISTRIBUTION
(Existing Trend)

Small base: few children born in the city.
Larger 'abdomen': more males, transient, single-member household.
Few elders: remigration to rural villages.

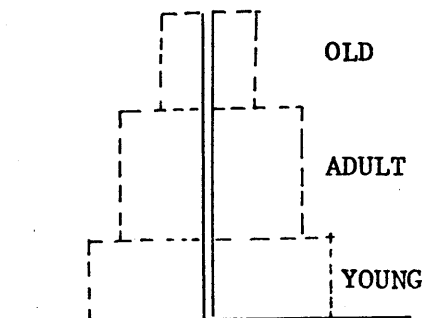

Fig. 2

AGE-SEX DISTRIBUTION
(Alternative Trend)

More even age-sex distribution.
More children than other age groups.
Almost equal ratio of male to female (due to less rural-urban immigration).

On the assumption the population trend will stagnate as shown in figure 1 (more adults than children and old people), the rental plots will continue serving the needs of the transient single-member households who travel back and forth every now and then to visit their families in the rural villages. If the projected trend occurs (a more even age-sex distribution due to less immigration), then all or almost all rental plots will transform into either lease or freehold property.

As economic forces give rise to new development pattern, and rising incomes and standard of living are felt, the existing income distribution pattern may alter (Figures 3 and 4).

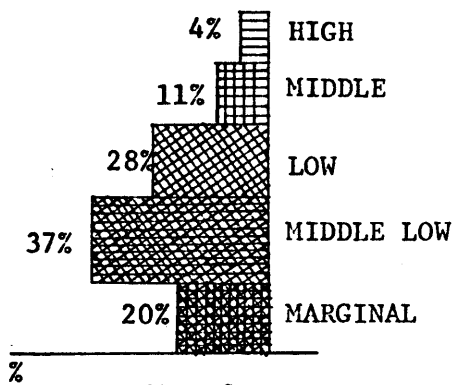

Fig. 3
INCOME DISTRIBUTION
(Existing Pattern)

The low income sectors form about 85% of entire city population with about 20% on the marginal income segment.

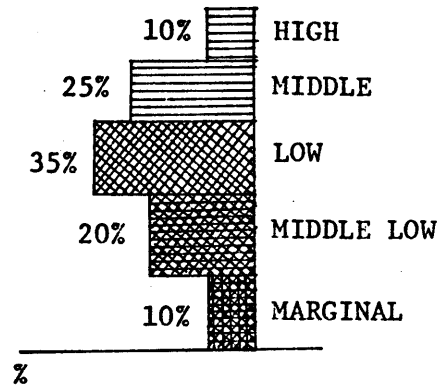

Fig. 4
INCOME DISTRIBUTION
(Alternative Pattern)

The low income sectors may form about 65% of population with only about 10% marginal income segment.

On the assumption that about 20% of the population are marginal, rental plots are designed to the reach of their resources. If this trend alters as shown in Figure 4, the subdivision will remain 10% rental. It may be possible at that stage for the government to aid the small percentage of the population through provision of public housing.

As the above assumption predicts, the design provides many more alternative routes to individual choices. A most common and typical example would be a marginal income family household starting as renters during the incipient stage of the site development, and ending up acquiring freehold tenure by the saturation period. Many more similar examples or projections of the likely route to be taken by various families could be made. The processes that will occur may take one or two generations depending on socio-economic forces affecting each family's mobility.

Figure 5 illustrates a trajectory of such family status over time.

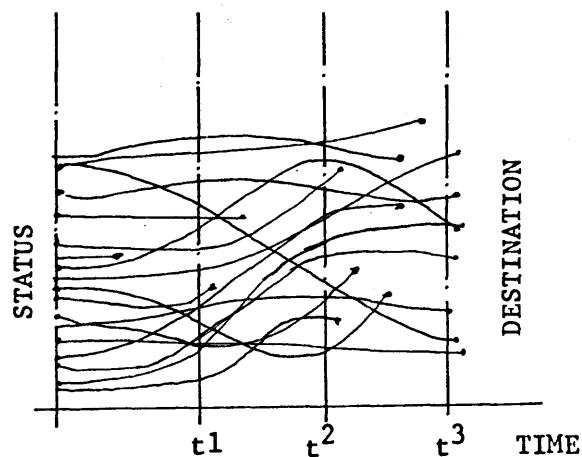

Illustration of socio-economic routes likely to be followed by various family types over time, showing range of alternative destination attained.

6.3 - Conclusions

This thesis has endeavored to discuss housing in terms of relationships between people and things, both of which change. Mr. J. C. Turner in his paper to the U.S.A.I.D. workshop on squatter settlements delivered in Washington D.C. on November 1969, pointed out that "...housing ought to be evaluated in terms of the match between the habitat and the inhabitant." If one sees housing needs in terms of geographic location and ecological demands of the family, in terms of social as well as physical amenities and in terms of tenure, then it is easy to anticipate and avoid mistakes and housing problems as observed in Chapter 3 of this work.

But if on the other hand, one sees housing needs in terms of physical standards of the structure and its equipment, then one will be constantly disappointed by the results of the action taken to improve material standards. The demand for adequate housing is far too great for the government of a developing country like Nigeria to afford the necessary sources for dealing with the problem in terms of material standards.

A P P E N D I X 1

Dwelling plots analysis

Objective:

To develop a system or a tool for evaluating the efficiency of the dwelling plot, and the implications of that plot in the layout of the dwelling unit.

Constraints:

The width of the dwelling plot is its most critical dimension. Changes in plot width affect greatly the efficiency of the housing block. Because each plot must receive services and utilities, any reduction in the width of plots yield a higher relative efficiency in the application of these facilities. More simply, the more housing plots per run of utility, the greater the economic savings in the installation of these facilities.

To formulate a system for evaluation of dwelling plots, therefore, some constraints were established by which the study was limited to the realm of reality. The following constraints were devised:

--- A 4 story maximum height. The four story height was reasoned to be at the upper limits of walk-up housing, and quite probably beyond the maximum height to which a self help structure would be built.

--- A minimum plot width of one room, and a maximum plot width of four rooms. The one room minimum plot width was determined to be the

minimum useful plot width, and the maximum four room plot width was established as the upper limit on the basis that it is tending towards a semi-detached dwelling .

--- An optimum of two independent dwelling structures per plot, if arranged one in front and one in the rear. This maximum per plot was viewed as a desirable possibility to increase utility efficiency, and as a workable maximum of plot saturation.

--- A dwelling unit cannot be more than two room deep, each with exposure at both ends.

Modules

Having defined the limits of the problem, a nomenclature was developed for ease of evaluation. The most reasonable approach was to utilize the existing modular systems used in the country (Nigeria), which corresponds to that employed throughout the world. The basis of these systems is component dimensions such as those of brick, concrete block, or dimensionally standardized materials. Basically, these component dimensions or modules lie within the range of six meters, seven and half meters, or ten meters, which have been found to be the most prevalent international modules. However, these component modules are not very useful for defining use of space dimensions. To do this, a module which is scaled to the use of furniture and the space necessary for its use, was employed. This module was called the element module 'E', which was in fact an aggregate of a convenient range of component dimensions. It was found that the useful limits of this element module lie between 90 cm and 125 cm.

Minimum, flexible, and efficient room dimensions can be based upon the element module grid, which is a function of the main components of the room. It is important to point out that small increases in the dimensions of a room are not advantageous. On the contrary, they may unnecessarily complicate construction. Once satisfactory dimensions for a room are established, other rooms should be laid out on the same element module. Changes in room size, either larger or smaller, should be by significant dimensions so that the changes have practical advantages and real meaning. A significant dimension or increment of change may be one element module (90 cm to 125 cm), but not a small dimension increment like 10 cm or 20 cm.

This module is valid not only in a plan but also in an elevation. Since element modules are based on component modules, which are consistent three dimensionally, single element module must also be consistent in three dimensions. This is a cubic module then, ranging from 90×90×90 cm to 125×125×125 cm.

Lot width

The system here described is in terms of the above defined element module. Approaching the first width of the dwelling, the module was further defined in the form of a room module and a plot module. These are all ultimately based on the component modules. The room module illustrated in the plot width chart (p.71), is an aggregate of element modules. There are two basic room modules: the living space module or large room module of from three to four elements ('E'); and the utility module or small room

module of from one to two elements. The one module width is an obvious minimum space width useful only for circulation or storage.

The two module width offers more use possibilities in circulation (stairs), or possibly use as toilet, kitchen, or utility rooms. However, the three and four module widths define the minimum and maximum living space dimensions (generally applicable). Three modules at 90 cm each, comprise the minimum useful dimension for a room. The plot module then ranges from one room width (three 'E' minimum) to four rooms width (twelve 'E' maximum).

Structural span

Some further constraints had to be applied to define the structural implications. A maximum span of six 'E' (minimum 540 cm) could be accepted in the interest of structural flexibility. The plot width chart (p. 71) gives the possible choices of room width combinations and structural span combinations available with each choice of plot width.

Plot depth

The 'maximum-minimum representation' chart develops the plot depth limits of each of the large to small room combinations established in the plot width chart.

The courtyard depth was formulated as a function of the building height for sun penetration. The court depth was then set equal to the maximum height potential of four stories. Floor to floor height was set at three 'E' allowing a range of from 270 cm (where 'E'... 90 cm) to

375 cm (where 'E'... 125 cm). The court then was defined as 4E×3E or 12E. A carport could also be introduced, basing its depth on the car, a depth of 6E could be gained in the court.

The room proportions defined have foundations in one basic principle and assumption: in the interest of critical plot width, the room may be deeper in the plot depth than its breadth (square rooms fail in the recognition of width factors). The maximum room width depth was set at no greater than twice the width.

Compilation:

The plot area relationship chart, page 73, is a compilation of plot areas and plot width to depth ratios for each of the many plot choices which fall within the constraints of the plot study analysis (only few are listed in this appendix). This chart is good for a variety of uses:

-- Knowing the area of land needed per plot, one can readily determine the range of plots available.

-- If one should want to subdivide an existing plot, he could consult the chart for subdivision possibilities.

-- One can check the chart against local codes and zoning ordinances to reveal the choices which must be excluded.

-- Plot combinations may be explored by comparing plots of compatible depth.

LOT WIDTH CHART

		3E	4E	5E	6E	7E	8E	9E	10E	11E	12E		
ROOM WIDTHS	GENERALIZED	1 large room	L	L									
		1 large-1 small		LS	LS	LS							
		2 large				LL	LL	LL					
		2 large-1 small					LLS	LLS	LLS	LLS			
		3 large							LLL	LLL	LLL	LLL	
		3 large-1 small								LLLS	LLLS		
		4 large										LLLL	
	ACTUAL	1 room	3	4									
		+ 1 E		3.1	4.1								
		+ 2 E			3.2	4.2							
		2 rooms				3.3	4.3	4.4					
		+ 1 E					3.3.1	4.3.1	4.4.1				
		+ 2 E						3.3.2	4.3.2	4.4.2			
		3 rooms							3.3.3	4.3.3	4.4.3	4.4.4	
		+ 1 E								3.3.3.1			
		+ 2 E									3.3.3.2		
		4 rooms										3.3.3.3	
		STRUCTURAL SPANS	1 primary	3	4	5	6						
			+ secondary			3.2	4.2						
			2 primary				3.3	4.3	4.4 5.3	5.4 6.3	5.5 6.4	6.5	6.6
+ secondary							3.3.2		4.4.2				
3 primary								3.3.3	4.3.3	4.4.3	4.4.4		
+ secondary										3.3.3.2			
4 primary											3.3.3.3		

E = ELEMENT MODULE (90 cm - 125 cm)

L = LARGE ROOM (3E - 4E)

S = SMALL ROOM (1E - 2E)

MAXIMUM - MINIMUM PLOT REPRESENTATION

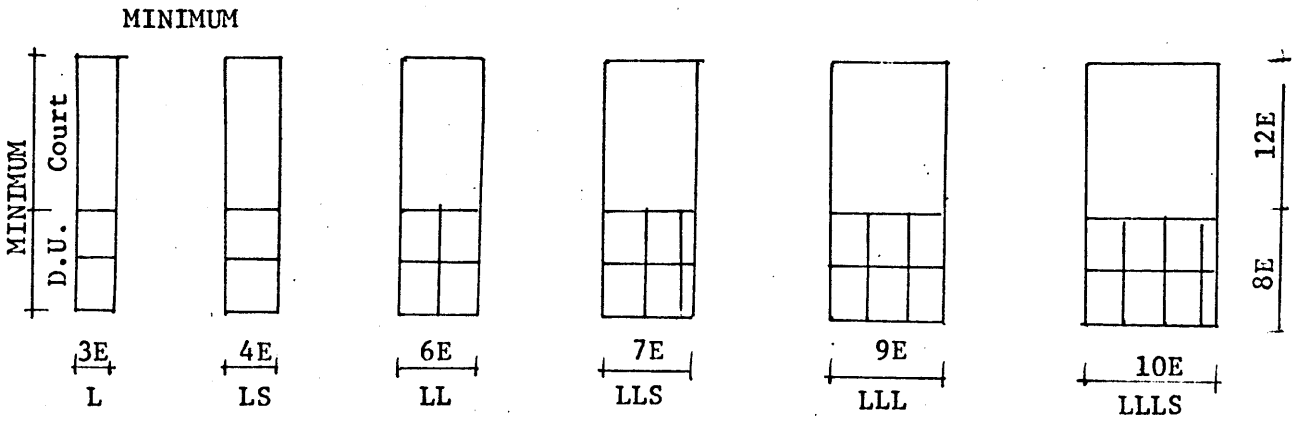
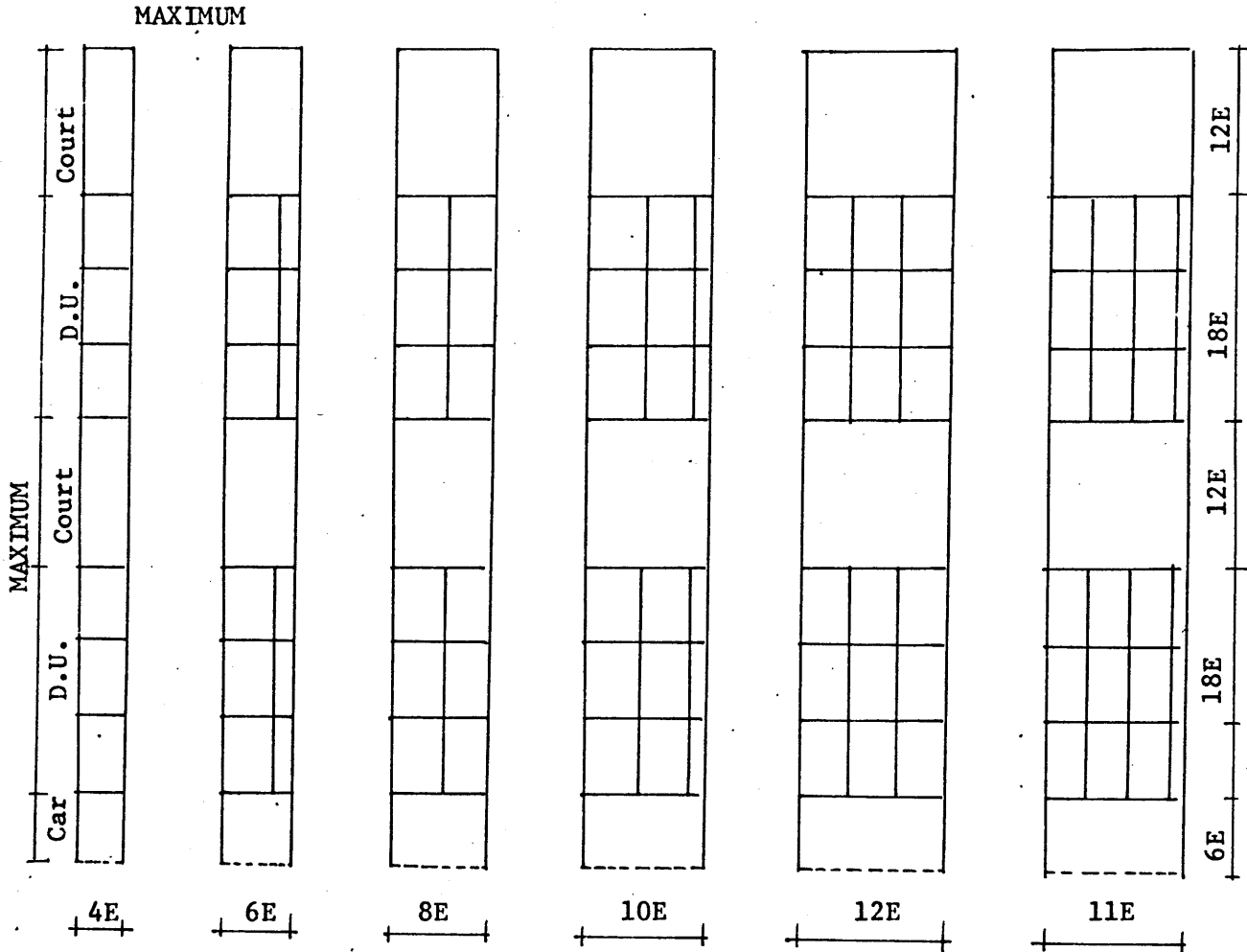

E = Element; L = Large room (3E-4E); S = Small room (1E-2E)

PLOT AREA REPRESENTATION

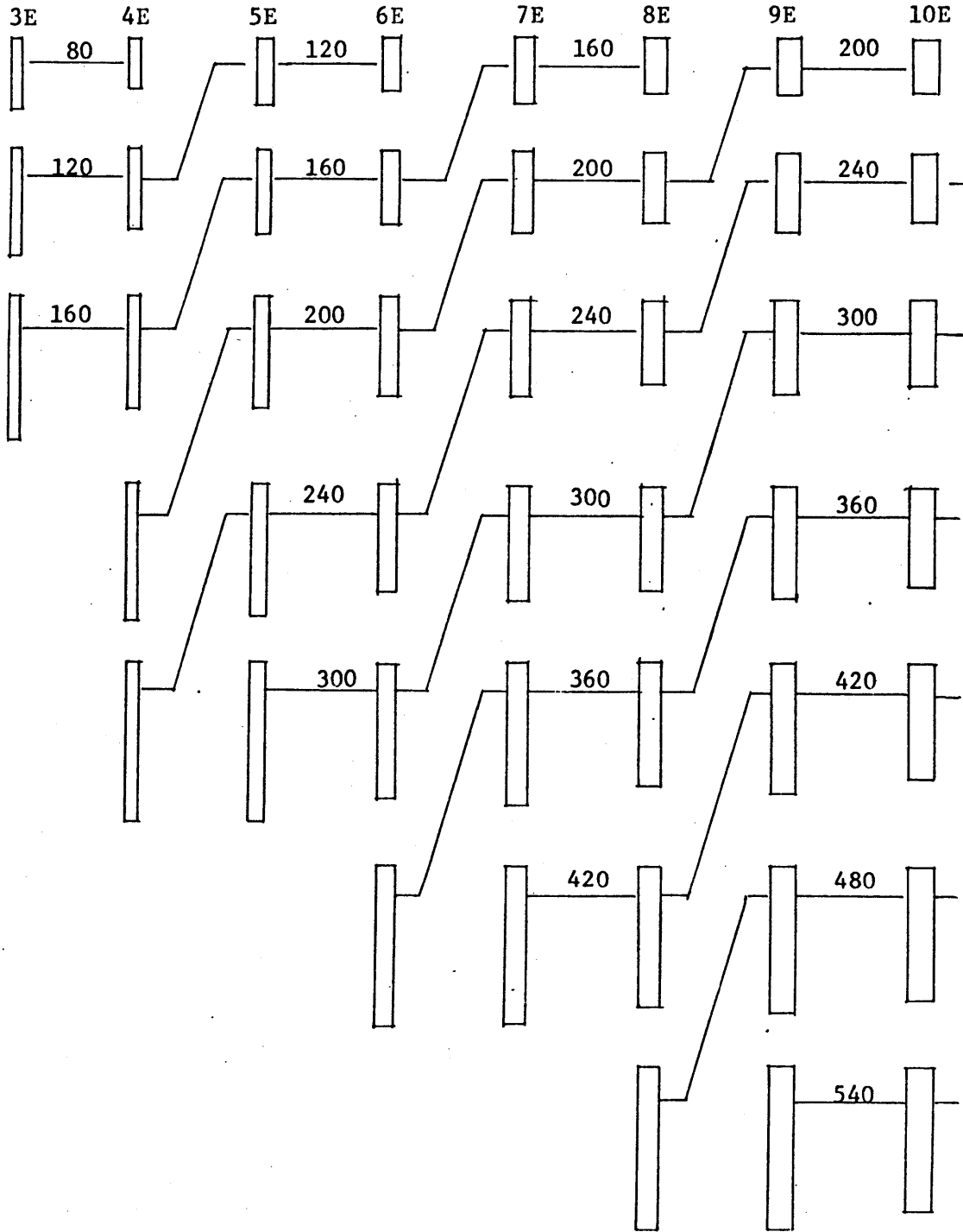

APPENDIX -2-

CLASSIFICATION OF ROADS.

Traffic	Surfacing	Base	Sub-Base	Application
10,000 plus	7½ cm bituminous premix	Cement bound granular material or crushed rock	Concretionary gravel (perhaps stabilized with cement or lime)	Primary Distributor (30 m)
5,000 plus	5 cm bituminous premix	Concretionary gravel stabilized with cement or lime	Concretionary gravel	District Distributor (21 m - 30 m)
2,000 plus	Bituminous surface dressing Later 5 cm premix as required	Concretionary gravel		Local Distributor (10 m - 20 m)
about 1,000	Concretionary gravel	Concretionary gravel		Access (3 m - 6 m)

The construction proposed here is to make use of locally available material as far as possible. Also, the classes are progressive so that a minimum of abortive work would be involved in upgrading in class as traffic intensities increase.

B I B L I O G R A P H Y

1. Abrams C., Forbidden Neighbor, 1956.
2. Ademola W. and Enwonwu B., The Federation of Nigeria, Harrap, London 1962.
3. Basden G. T., Niger Ibos, Seeley Service, London.
4. Baran P. A., On The Political Economy of Backwardness, 1958.
5. Caminos, Turner, and Steffian, Urban Dwelling Environment, M.I.T. 1969.
6. Chadwick E. R., Our Community Effort in the East (undated).
7. Coleman, Nigeria, Berkeley 1960.
8. Childe V. G., What Happened in History, 1954.
9. Federal Nigeria Ministry of Economic Development, Nigeria National Development in the Eastern Provinces of Nigeria, Enugu, Nigeria, 1950.
10. Govt. Printing, Enugu, Plan for Community Development, Enugu, Nigeria.
11. Hagen E., On The Theory of Social Change, 1962.
12. Hanna W. J., The Study of Africa, Journal of Administration Overseas, 1966.
13. Hodgkin T., Nationalism in Colonial Africa, N.Y. Univ. Press, 1957.
14. Kimble G. H. and Ronald Steel, Tropical Africa Today, N.Y. McGraw-Hill, 1966.
15. Locks M. and Partners, Kaduna, 1968.
16. Little K., West Africa Urbanization, Camb. Press, England, 1965.
17. Marris P., Family and Social Change in an African City.
18. McColl D. F., Dynamics of Urbanization in Africa (Annals of American Academy).
19. McClelland D. C., The Achieving Society, Free Press, N.Y., 1961.
20. Olgyay V., Design with Climate, Princeton, 1963.
21. Olusany P. O., Adequacy of Existing Census and Vital Statistical Research, 1966.
22. Omide S. H., Land and Population Movement in Kenya, 1968.
23. Peattie L. R., The view from the Barrio (undated).
24. Turner J. C., Uncontrolled Urban Settlements - Problems and Policies.
25. Turner J. C., A New View of Housing Deficit.
26. United Nations, Housing in Ghana, 1957.
27. United Nations, Metropolitan Lagos, 1964.
28. United Nations, International Social Development Review (I): Urbanization.
29. United Nations, International Wage Structure in Certain Parts of Africa, 1958.
30. Lloyd P. C., The New Cities of Tropical Africa, London 1966.
31. Mayer P., Migration and Study of Africans in Towns, American Anthropologist, 1962.