

FORM AND DAYLIGHT AS A CREATIVE MEDIUM:

Church of John Paul II in South End, Boston

by Jaroslaw Gruzewski

Bachelor of Architecture and Urban Planning
Warsaw Technical University
Warsaw, Poland, June 1983

Submitted to the Department of Architecture in partial fulfillment
for the degree of **MASTERS OF ARCHITECTURE** at the
Massachusetts Institute of Technology.
February 1992

© Jaroslaw Gruzewski 1991. All rights reserved.

The author hereby grants to M.I.T. permission to reproduce and
distribute publicly copies of this document in whole or in part.

Signature redacted

Signature of the Author

Jaroslaw Gruzewski
October 18, 1991

Signature redacted

Certified by

Cameron Roberts
Lecturer
Thesis Supervisor

Signature redacted

Accepted by

Jan Wampler, Associate Professor
Chairman
Departmental Committee on Graduate Students

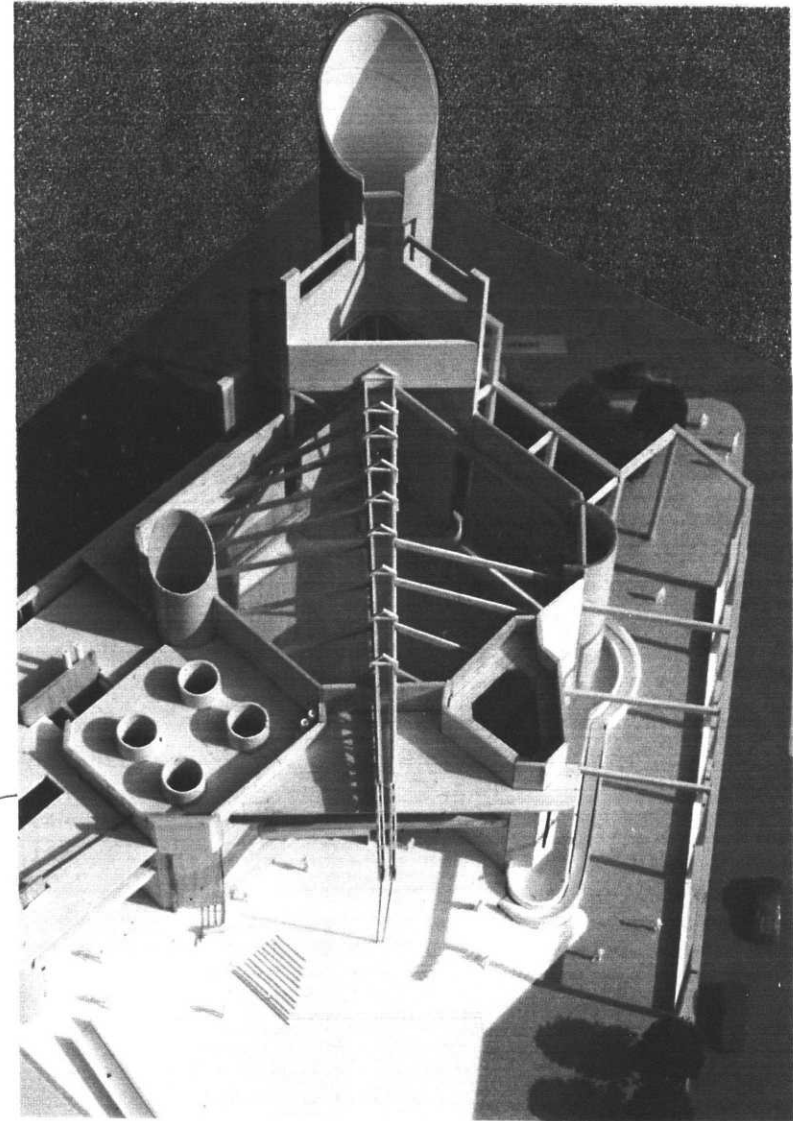

MASSACHUSETTS INSTITUTE
OF TECHNOLOGY

FEB 21 1992

LIBRARIES

ARCHIVES

this thesis would not have been possible without the exceptional help and support of Mr. and Mrs. G.L.Piasecki to whom this work is thoroughly dedicated.

ACKNOWLEDGMENTS:

First of all let me thank my thesis project advisor, Cameron Roberts, and critics John Myer and Imre Halasz for their immense help and for words of advice throughout my thesis design procedure. Very special thanks to Professor Jan Wampler whose significant teaching methods introduced in his studio primarily influenced my thesis subject and added new values to my design approach in the field of architecture.

I am also grateful to the following :

Linda Okun, for her extraordinary and continuous support as my Faculty Advisor,

Leon Groisser for outstanding help and truly kind understanding of all my "big and small problems,"

John Myer, for his letter of support which encouraged me in my long struggle to become a MIT graduate student. It has been a great pleasure working as his assistant.

I would also like to thank the distinguished and internationally recognized Massachusetts Institute of Technology, Department of Architecture for giving me the privilege and an opportunity to improve my knowledge and professional skills.

My deepest gratitude to my advocate and sponsor Mrs.Barbara P.Johnson for her remarkable help and exceptional support of my graduate study over the last two years.

CONTENTS:

Title Page i
Dedication iii
Acknowledgments v
Contents vi
Abstract viii

PART ONE: Introduction

Introduction 10
Controlling the light 14
Daylighting Principles 26

PART TWO: Research

Masters of Form and Daylight in Architecture: 34
Alvar Aalto 36
Johannes Exner 40
Jorn Utzon 46
Le Corbusier 52
Louis I. Kahn 54

PART THREE: Design

Site Description 58
Site Photographs 60
Form and Daylight as an Organizing Device 68

“No space, architecturally speaking, is a space unless it has natural light ... ”

Louis I. Kahn

Application of Daylighting 80
Sanctuary's Daylighting104
Plans and Drawings112
Program126

PART FOUR: Reference

Sources of Illustrations 128
Bibliography 134

ABSTRACT:

FORM AND DAYLIGHT AS A CREATIVE MEDIUM:

Church of John Paul II in South End, Boston

by Jaroslaw Gruzewski

Submitted to the Department of Architecture on October 16, 1991 in partial fulfillment of the requirements for the degree of Master in Architecture at the Massachusetts Institute of Technology.

Thesis Supervisor: Cameron Roberts, Lecturer

Thesis Critics: John Myer and Imre Halasz, Professors

"... as a few things have so much effect on the feeling inside a room as the sun shinning into it."

Christopher Alexander

This Thesis is an architectural design project of a Catholic Church dedicated to Pope John Paul II.

The main intention of this Thesis is to explore and clearly present daylighting methods and techniques and how important role they can play as the formgivers for an architectural design. This Thesis will also provide an answer for making daylight design process more inspiring and free from often misleading, graphic "artificial" methods. In my opinion, daylight design requires professional knowledge and sensitivity much beyond simple technical rules or restrictive tables. I believe, that daylight is a visual phenomenon "in motion", and cannot be fully captured and framed under scientifically provided guidelines. This Thesis will also research a vital architectural design issue, that "daylighting is not something one adds to building design - it is implicit to every design decision."¹

Through the method of this Church's architectural design process, I will explore the potentials and limitations of daylight and its qualities. I will also present how both light

1. quotation from: Lam, William M.C., *Perception and Lighting as Formgivers for Architecture*, New York, McGraw-Hill, 1977.

and architectural form can be used to strengthen the spatial experience.

Finally, this Thesis will answer questions regarding the provision of light for the performance of visually related activities in the Church of John Paul II, including the Baptistry, Reading Room, and Auditorium. For most of us, Vision is the most powerful of our five senses and the main receptor of information, conditioning our memory and imagination. Sight (light, form and color) is the primary medium through which our surrounding is seen. Therefore, architecture receives its most powerful and true expression through the mediums, of sight as well as "form and daylight".

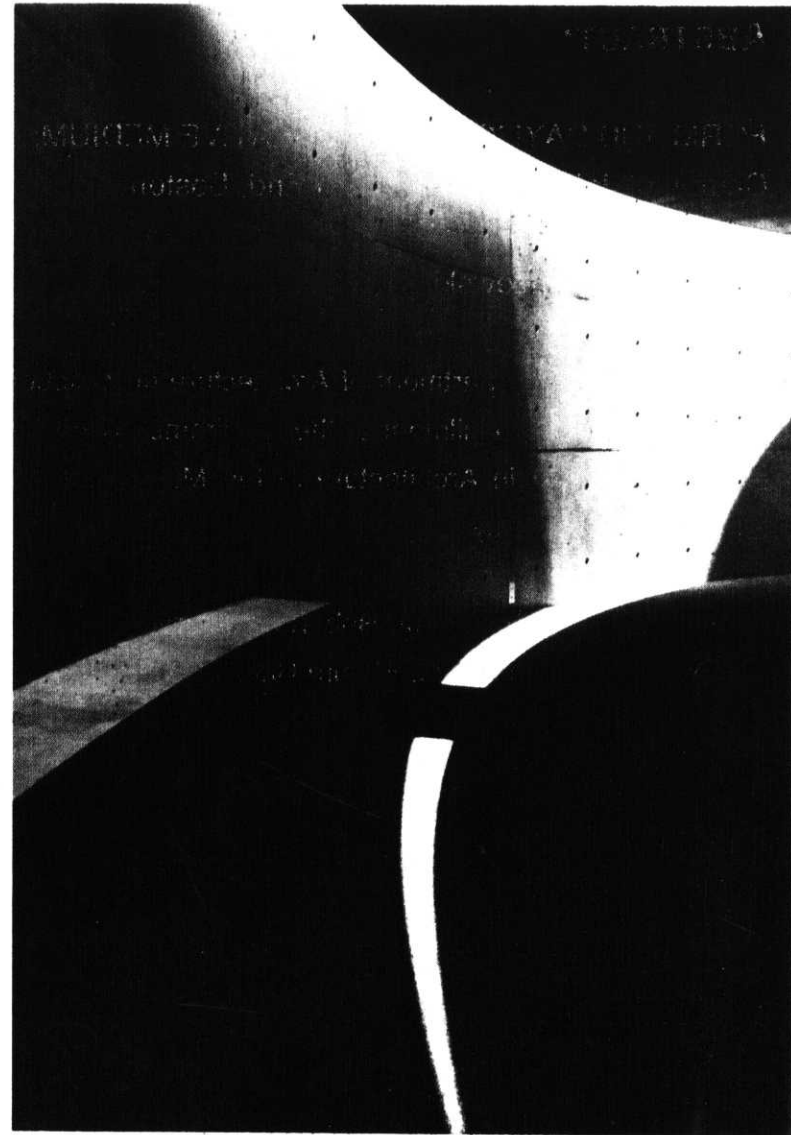

PART ONE: INTRODUCTION

“Every architectural form, every building or group of buildings, regardless of the practical purpose or the expressive need that formed it ... is a visible form built from differences of light qualities, ... Within our perception of these patterns of light, our distance sense, our appreciation of the qualities of a wider space would completely disappear.”

Louis I. Kahn

The fascination with sunlight derives from our most fundamental biological and esthetic needs. For centuries, daylight and related weather conditions have created the basis for our life's activities and schedules, as well as established some rules for the shape of our shelter. Sunlight can be easily predictable in its direction, cycles of day and seasons of a year. Orientation in time and the immediate surrounding are very important to the survival and well-being of the human race. However, daylight is unpredictable in its varying patterns of weather, creating shadows, and reflections. The opportunities and challenge of architecture and building technology can be found in this idea. Daylighting in architecture depends on the relationship between the form, available technology, and geographical location, not to mention the architect's imagination.

The lighting challenge for the present is to use the sun and architectural form to provide spatial and thermal comfort according to the purposes for which each space is designed.² Today's technology enables us to successfully combine buildings' complex programs with their spatial, visual and thermal comfort. A properly

2. based on: Philips Derek, "Lighting in Architectural Design", McGraw-Hill, 1964.

developed design, which uses fundamental techniques for daylighting and form manipulation may:

- minimize building energy cost
- provide spaces with thermal and optical comfort
- provide an architectural form with a variety of unusual visual effects
- minimize construction costs
- provide interiors with unique atmosphere
- define use purpose of a space³

The following chapters of my thesis present and answer the question of what kind of principles and methods of daylighting design are available. How can they be used to fulfill the basic requirements for well designed spaces from the form and daylight point of view? These particular aspects of architectural design interest me the most because, in my opinion, architecture receives its most powerful and true expression through the medium of form and daylight, and not through the design of fixtures, interior details, or building materials.

3. Lam, William M.C., "Perception and Lighting as Formgivers for Architecture," New York, McGraw-Hill, 1977.

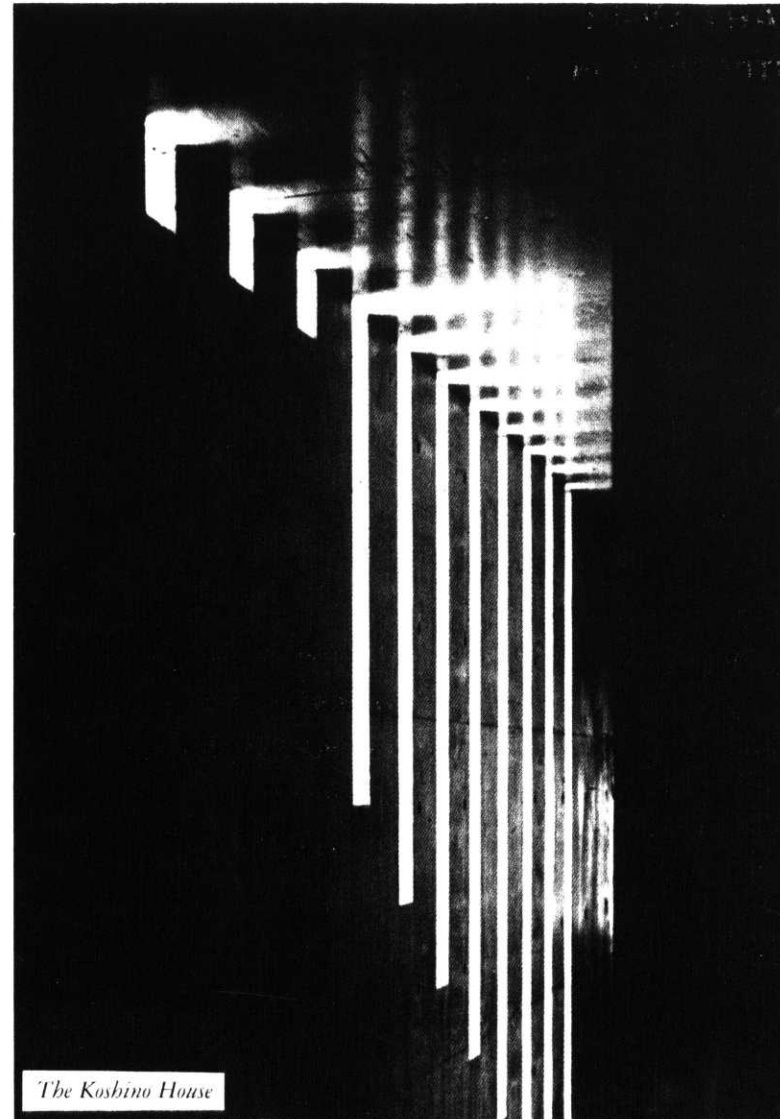

CONTROLLING THE LIGHT:

“Our human nature is profoundly phototropic. Men obey their deepest instincts when they hold fast to light in comprehensive acts of perception and understanding through which they learn about the world, orient themselves within it, experience joy in living, and achieve a metaphoric symbiotic grasp of life.”

Nathan Lerner

Architecture is the setting for human experience, a mirror of light and form and the shadows created by them. The greatest masters, creators of spaces in stone, brick, steel, and glass often treated the windows, doors, and passages as the filters; entry points to pass between light and shadow realms. They all understood that light gives objects existence as objects and connects space and form.⁴ They understood how important it is to control daylight, for which proper quantity and distribution are elementary.

The quantity of daylight illumination inside the space is a function of:

- ⁵1. **daylight availability**
2. **fenestration**
3. **site (orientation)**
4. **space size**

The daylight availability depends on geographical location, season, time of day, weather condition, microclimate and air pollution. Fenestration concerns include sun control, wall systems, size and location, transmission characteristics and maintenance. The site

4. Murray, David, *Architecture and Shadow*, University of Pennsylvania, Rizzoli, 1990.

5. Hopkinson, R. G., "Sunlight in Buildings," in "Proceedings of the C.I.E. International Conference," April, 1965.

must be considered in terms of latitude, orientation, and landscape. Orientation is a key factor in obtaining daylight. In commercial buildings, south windows usually need some kind of shading. East and west openings need shading at different times of day, and are suited to easily adjustable shading devices which will be briefly discussed on the following pages. North windows receive the most diffuse light, but may require shading on a bright day (tinted or reflective glass and foils for example).

Space size, is very important as far as room geometry is concerned, as are walls' reflectance, furniture color and maintenance. Even though present technology offers "high-tech" glazing materials like photochromic glass,⁶ which changes color in response to changes in available light or selective-transmission glass, which admits visible light while blocking heat, clear glass with a combination of exterior and interior light control devices still offers the best solution for effective daylighting. To achieve it, it is important to :

- reduce direct radiation
- eliminate excessive illumination on interior surfaces
- provide designed spaces with diffused sunlight

6. Vonier, Thomas, ed., "Proceedings, International Daylighting Conference," Washington, D.C.: American Institute of Architects Service Corporation, 1983.

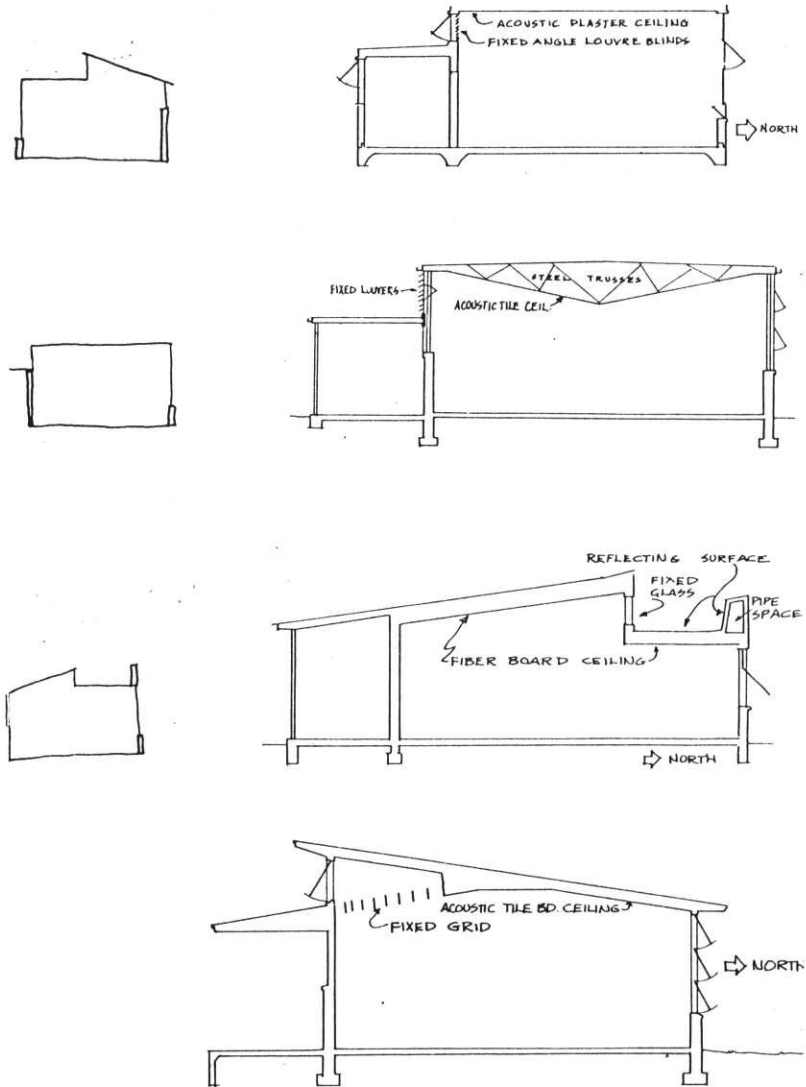

No Overhang

Small window head (to allow penetration of sky light)

Concrete, white gravel, or white pavers ($\rho = 55\%$) are better reflectors than asphalt or dark green grass ($\rho = 5\%$)

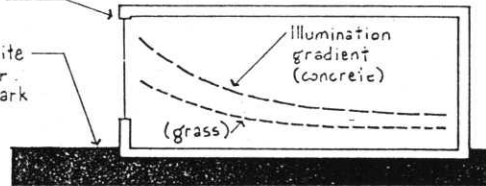

Short Cantilever

Reflected ground light

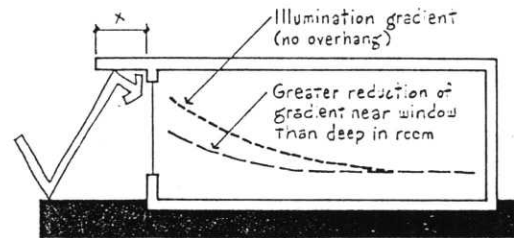

Wide Cantilever

Low sill height (to allow penetration of reflected ground light)

1-01

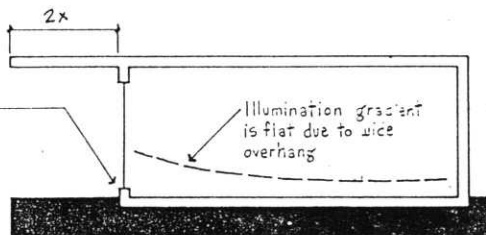

Generally, there are two groups of daylight controls: exterior and interior. The first group consists of:

1. overhangs (horizontal, sloping)
2. louvers (horizontal, vertical)
3. louvered overhangs
4. screens (awnings and shutters)
5. trellises
6. exterior lightselves

The main purpose of overhangs is to limit the impact of direct sunlight and heat on glazed surfaces during specified times of the day and the year. A sloping overhang's advantage over more traditional and commonly used horizontal ones, is to obstruct more of the sky light, (1-01, and 1-02).⁷ It is possible to define two other kinds of overhangs, translucent and opaque. The first ones have the advantage of providing weather control, which in some design cases may be an important issue.⁸ It is worth mentioning that in order to provide spaces with highly illuminated diffused light from this type of overhang, its surface should be painted white. Keeping an original, concrete finish is not always efficient enough,

7. information : Egan, David M., "Concepts in Architectural Lighting, New York, McGraw-Hill, 1983.

8. information : Lam, William M.C., "Sunlighting as a Formgivers for Architecture, New York, McGraw-Hill, 1990.

especially from the south side of a building and when long overhangs are used. The distance between two light reflecting surfaces is also very important, (1-03).

Another variation of overhang is a parapet wall, a very useful light controlling example. The best effects can be achieved when used in combination with a north facing clerestory. Here, southern daylight is reflected from the white painted parapet wall surface and directed through the clerestory onto the ceiling, (1-04).

Among external louvers there are three main types which are commonly recognized: vertical, horizontal and small window louvers. The last, window louvers are applied straight to a window and may obstruct the view to some extent, (1-05 and 1-06).

Vertical louvers are usually used to control sunlight on west and east building facades. They are also helpful to restrict sky brightness on north elevations. More popular horizontal louvers are most effective on the south facade. Here, tilt adjustable louvers are often used. They may be raised or lowered according to the time of day and ⁹

9. information : Lam, William M.C., "Sunlighting as a Formgiver for Architecture," New York, McGraw-Hill, 1990.



1-03

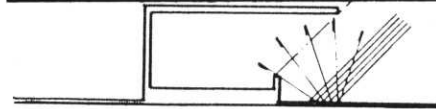

1-02 Because the overhang provides shading without redirection of the sunlight, sufficient foreground must be available to utilize ground-reflected light.

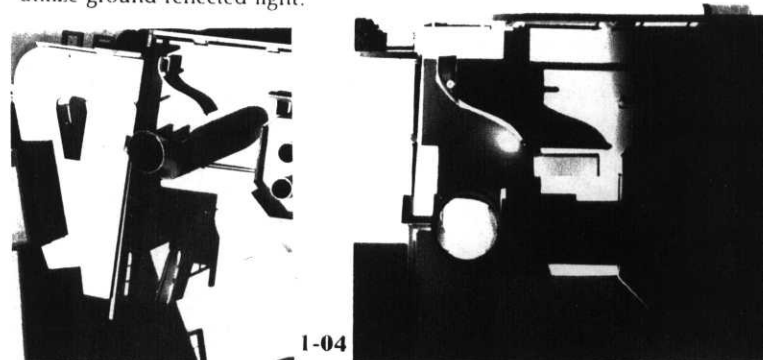

1-04

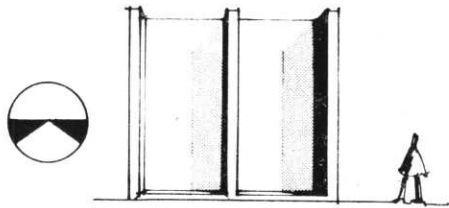

1-05 Vertical shading devices respond to the sun's bearing angle—its movement around the horizon. On a south wall, they shade at the beginning and end of a day.

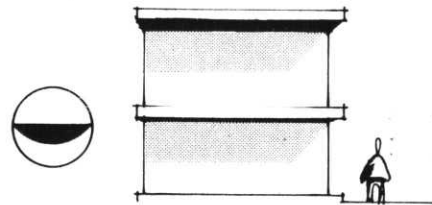

1-06 Horizontal shading devices respond to solar altitude. They shade most at noon, when the sun is highest.

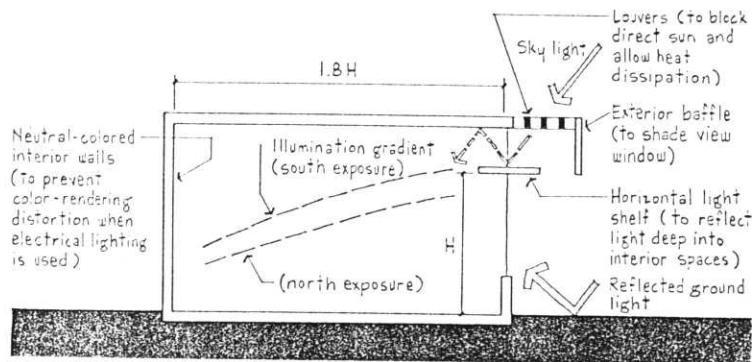

season. South European and some of Central and South American building spaces are protected by small external rolling louvers, which are applied on the window. There is only one disadvantage of this light control device - it may obstruct the view. But if the slats are fine enough, the eyes will maintain clear vision by putting the image together. While in Portugal, I used this type of louver for almost two years and found them helpful in protecting the rooms from early afternoon overheating. Permanently installed horizontal louvers would not be able to protect internal spaces from sunlight and heat the way rolling louvers do.

As far as the exterior louvered overhangs are concerned, they can be designed to limit solar radiation from direct penetration into a space. It is necessary to add that they allow the reflected sunlight to illuminate the visible surface of the room as well. If not opaque they also allow better utilization of the sunlight and skylight in the room.¹ Unfortunately, they cannot protect exterior spaces, corridors, passages from the rain which can downpour through them without any difficulties, (1-07).

1. information and hand drawing from: Egan, David M., "Concepts in Architectural Lighting," New York, McGraw-Hill, 1983.

Other exterior fixed light controls include, trellises, screens and shrubbery. These are used outside the building and play a secondary and rather supportive role in daylight control.² They can be individually designed, therefore, the variety is nearly endless. Materials include : aluminum, wood, fire flameproof fiberglass, yarns and polyester/linens for fabric screens, Owens-Corning fiberglass coated with Plastisol (which filters out the sun's heat while permitting natural light in), polyester felt, and fibers, to mention some.³ In further illustrated examples (1-08, 1-09 and 1-10) of the exterior light controls, mirrored lightshelves, are often used to provide the spaces with particularly precise amount of high quality diffused light in difficult to illuminate areas (i.e.: galleries, hospitals, sanctuaries, libraries and auditoriums).

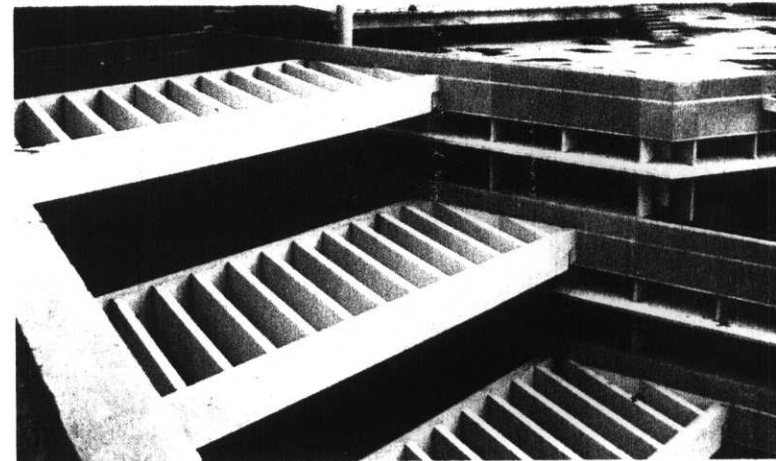

1-07

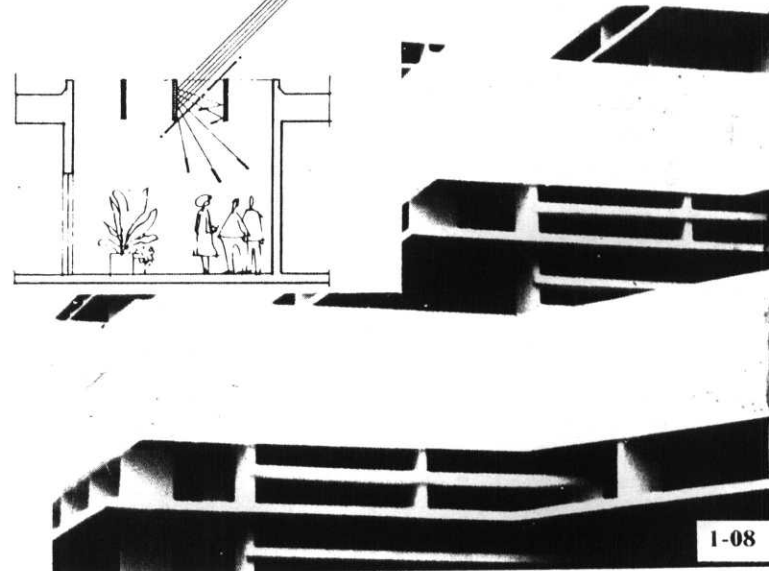
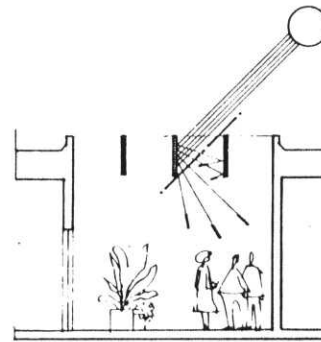

1-08

2. Olgay, V. and Olgay A., "Solar Control and Shading Devices," Princeton, Princeton University Press, 1963.
3. S.E.R.I. Solar Conservation Study, "A New Prosperity - Building a Sustainable Energy Future," Andover, 1981.

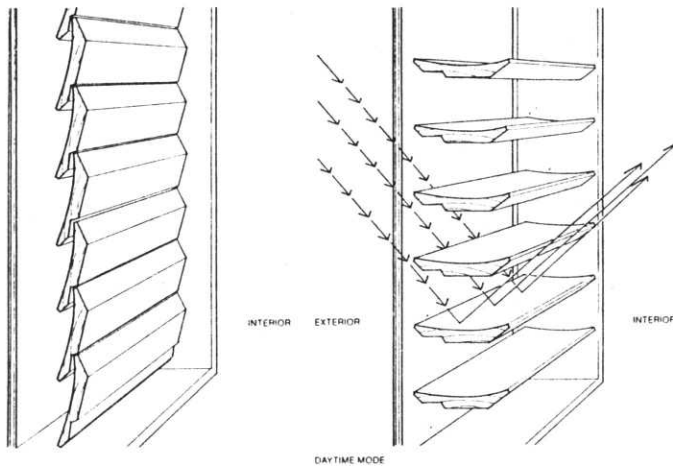

The second group of devices for limiting and diffusing light in buildings, interior light controls include:

- 4 1. blinds (louvers, vertical baffles)
2. shades and draperies
3. prism and mirrors
4. screens, reflective glass and foil
5. lightshelves
6. sliding curtains
7. skylight systems
8. sliding panels and screens
9. stained and directional glass (blocks)

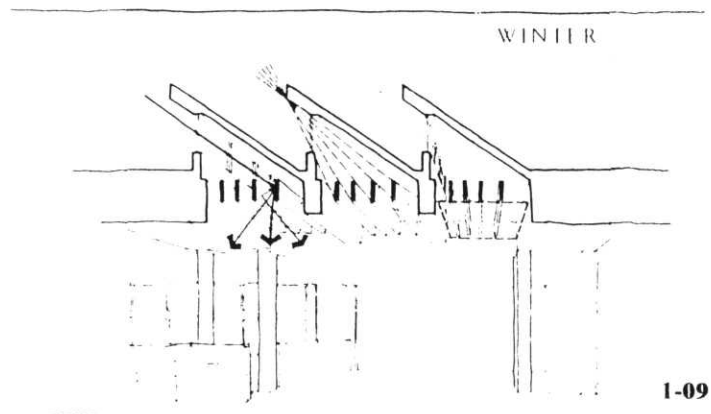

Two types of blinds can be recognized: horizontal (venetian) and vertical. Horizontal blinds are especially effective when used between two panes of glass. They offer the most versatile form of daylight control since they can be adjusted to direct sunlight, as well as to reflect solar radiation, and reduce glare from a bright sky. They admit a great amount of diffused light which is the most valuable for lighting purposes.⁵ Blinds are adjustable to any exterior light condition, considerably inexpensive, and almost maintenance free, if automatically controlled.

Some types of blinds, horizontal and vertical, can be

4. information for 1-9 from: Lam, William M.C., "Sunlighting as a Formgiver for Architecture," New York, McGraw-Hill, 1990.

5. Olgyay, V. and Olgyay A., "Solar Control and Shading Devices," Princeton, Princeton University Press, 1963.

used on angled, curved windows and skylights. Blinds are now available in many colors and finishes. White or reflective aluminum blinds reflect more radiation than other colors, but it is possible to have venetian blinds that are white or reflective on one side and another color on the reverse side. They are capable of reducing solar heat gain by 60 percent when completely closed.⁶ They can also reduce heat loss through conduction by up to 25 percent, creating an insulating layer of air between blind and pane of glass. Horizontal blinds have been used on clerestory windows in combination with light shelves, bouncing daylight deep into a space or toward the ceiling. Vertical blinds offer other possibilities. Unlike horizontal ones, which have to be rather rigid, vertical blinds can be made of fabric, which is a better insulating and humidity-balancing material. Vertical blinds are also easier to maintain. Their disadvantage is that the vertical openings between louvers tend to create sharp contrasts between shaded and unshaded glass. Some glare problems may occur. Another disadvantage of vertical blinds is that they cannot beam daylight deep inside the space, as can venetian blinds.^{7,8}

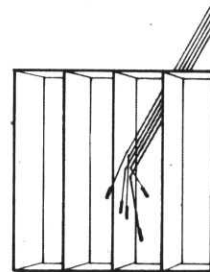

Vertical baffles always direct sunlight downward.

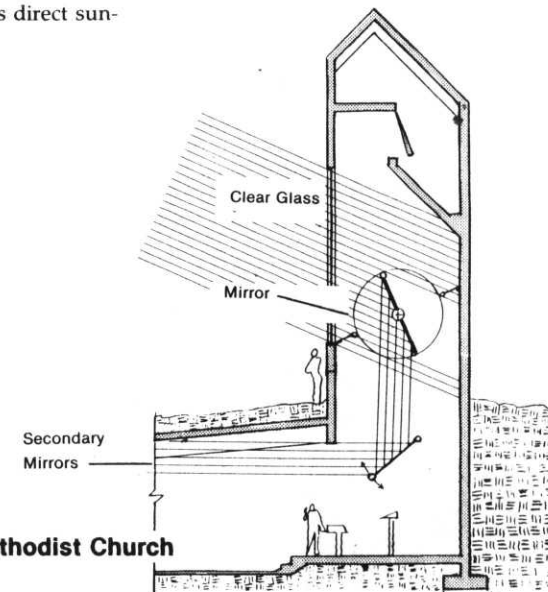
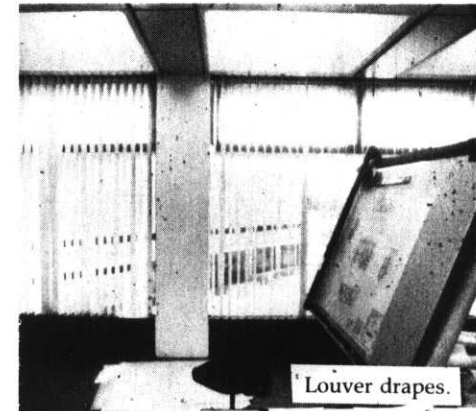

Central United Methodist Church

6. Rosen, James E., "Natural Daylighting and Energy Conservation," M.I.T Thesis, 1981.

7. "Daylighting Buildings," Conference, Imperial Collage, London, 1989.

8. Lam, William M.C., "Sunlighting as a Formgiver for Architecture,"

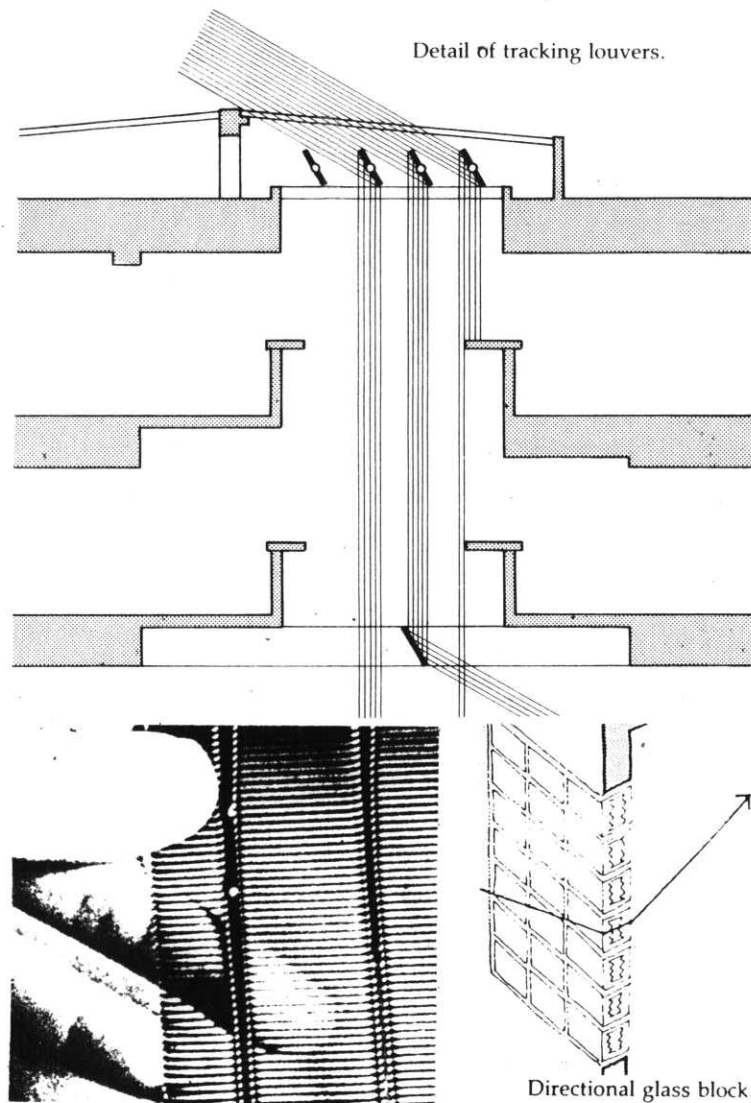

The most traditional window treatment, practical and easily operated, are shades and draperies. There are a few types of draperies: insulating (heat, sound), opaque (visual blackout) and translucent, which reduce visibility and rooms' overheating but may direct or diffuse daylight. Transparent roll shades can be recommended here because they reduce solar heat gain and allow good visibility at the same time, as some draperies do. It is worth adding that rather dark color shades, while having low reflectivity, are easier to see through than light-colored shades. Made of various forms of aluminum, semi-transparent polyester films offer good shading performance while limiting UV radiation.⁹ These film shades offer shading coefficient figures that are lower than those of horizontal blinds when opened at a 45 degree angle. Some film shades (low-emissivity) can reduce heat loss by up to 90 percent, reflecting heat back into the room. Some solar shades can heat up and become large radiators. Unfortunately, film shades create undesirable nighttime reflections and scratch easily, that is why their use should not be extensive and should be carefully planned.¹⁰

9 . S.E.R.I. Solar Conservation Study, "A New Prosperity - Building a Sustainable Energy Future," Andover, 1981.

10. information from: Robbins, Claude L., "Daylighting: Design and Analysis," New, York, Van Nostrand Reinhold, 1983.

Prismatic glass blocks and milky patterned glass have been in use for a long time, but with limited success. Relatively high cost is one of many problems. Prismatic glass block was designed to accept sunlight and redirect it toward the ceiling as diffused light.¹ This may also be achieved using more spectacular light control - tracking mirrors. Usually, made of polished aluminum or brass foils to redirect diffused light, they can also provide a designer with an efficient daylighting tool to redirect strong beams of light in precisely chosen room areas.²

Tracking mirrors require dynamic control to either track or adjust incrementally to the apparent movement of the sun's and sky's changing conditions. These are very sophisticated and expensive controls. That is why their use has to be carefully considered in the context of the building performance and cost analysis.³

Another, less sophisticated daylight control strategy, often selected by architects, includes a variety of glass block glazing. Besides its beneficial esthetic and light blocking qualities, glass block cause some difficulties. The main problem for matte (milky) or stained glass blocks is that

1 - 3. information from: Lam, William M.C., "Sunlighting as a Formgiver for Architecture," New York, McGraw-Hill, 1990.

Low-Transmittance Glass Block

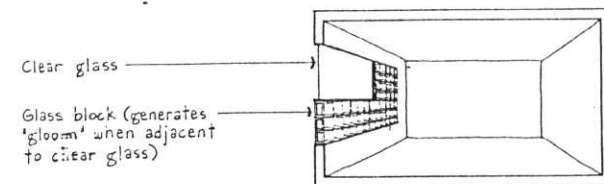

Light Shelves

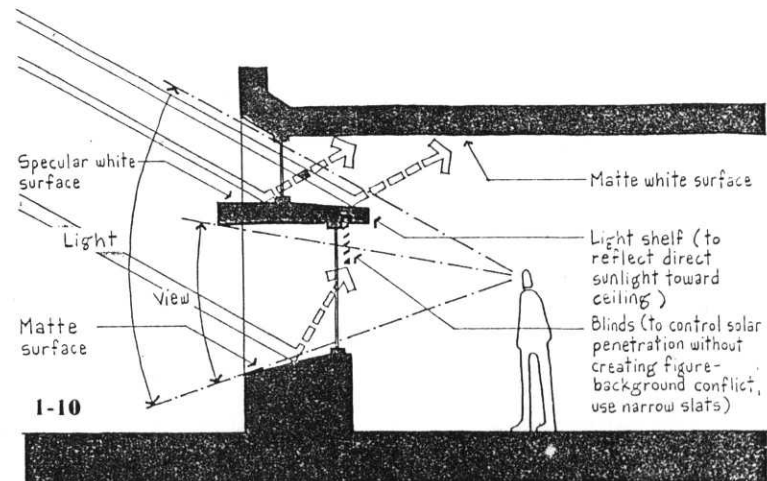

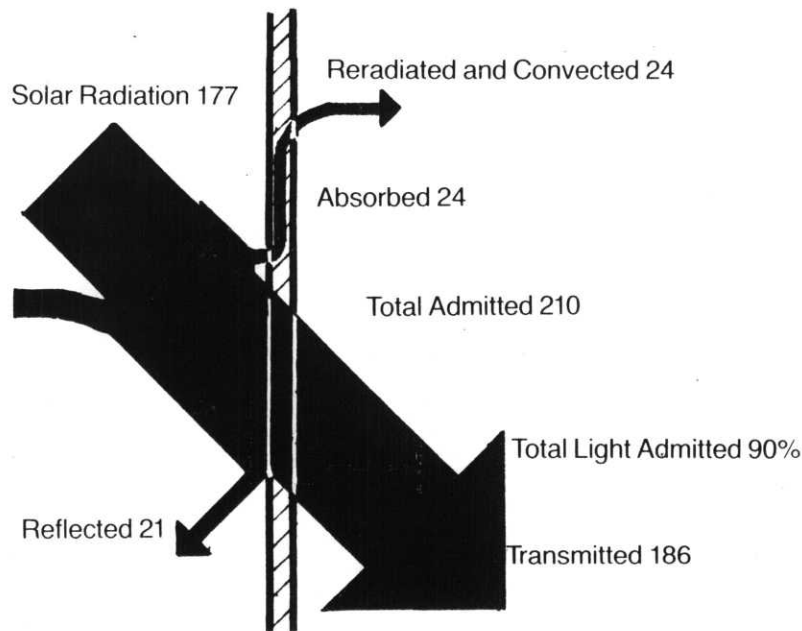

Transmission, reflection, and absorption-
-reradiation of clear single glazing.

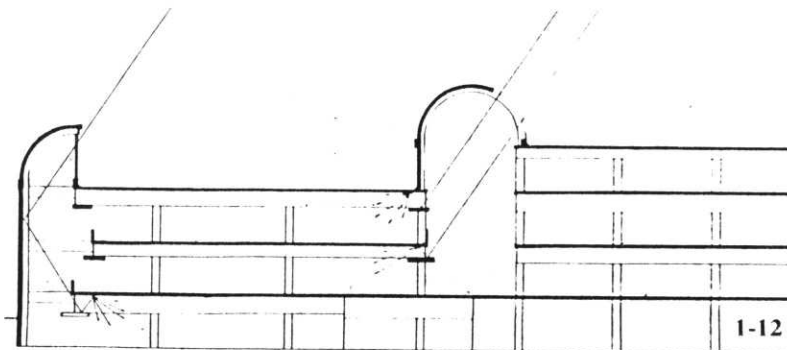

they keep the sunlight out when the heat and glare are excessive, but sometimes a certain amount of heat or light may be desirable. Without a doubt, some degree of light control in glazing is necessary, especially during sunny and hot summer days, but transmission of less than 50 percent is not valuable for daylighting purposes. Light, heat absorbing and reflecting "intelligent" glass blocks or other types of glazing have been already developed but their use is limited, due to their very high cost. So far, "intelligent" glass (phototropic) is commonly used in optical applications and to a degree, in the astrophysics and airplane construction business.⁶

Interior lightshelves can be installed to take advantage of reflected light from below or to reflect sunlight admitted inside a higher space, where it is then redirected towards the floor's surface. The lightshelves operate similarly to previously described exterior overhangs and may either diffuse or beam low-angle sunlight deep inside the space to which it is desired, (1-11).

6. text and drawings from: Lam, William M.C., "Sunlighting as a Formgiver for Architecture," New York, McGraw-Hill, 1990.

The following illustrations will answer the question of how lightshelves and other exterior and interior amplifiers can best be used for daylighting design purposes.

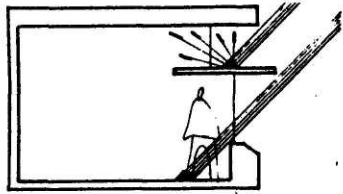

1-17 The lightshelf provides shading with redirection of sunlight.

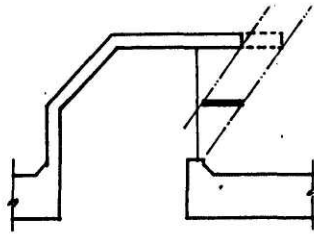

1-15 Sidelighting-type exterior louvers, overhangs, and fins can provide baffling for sunscoops as well.

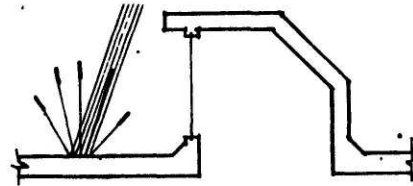

1-14 Lightscoops are clerestory monitors oriented away from the sun, receiving sky light and roof-reflected light. They provide the lowest and steadiest light levels with minimum annual heat gain.

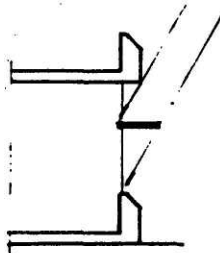

Hot climates.

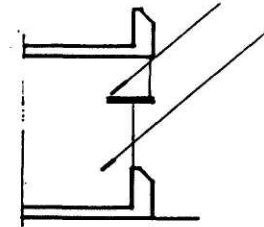

Temperate climate alternative: keep lightshelf on interior to optimize maintenance; control seasonal gain through lower window.

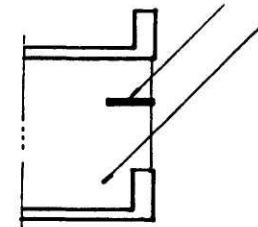

1-20 Cold climates: glazing flush, all sun admitted.

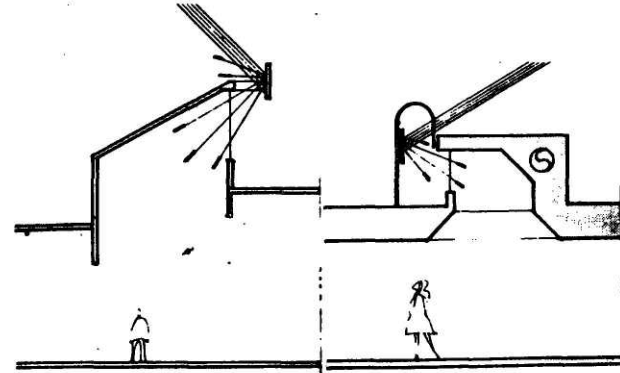
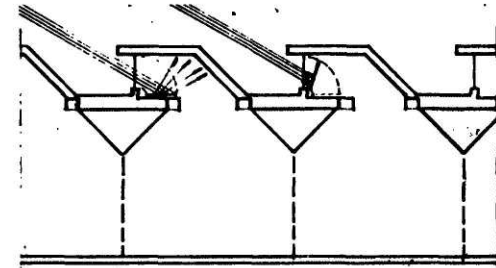
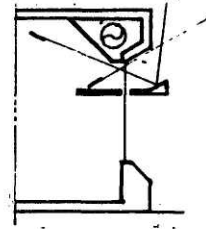

DAYLIGHTING PRINCIPLES:

"It is my wish that this quiet space ... will come to life through light and have an impact on people."

Tadao Ando

Daylight design requires professional knowledge and sensitivity much beyond simple rules and tactics. From a realistic point of view, a major obstacle to daylighting is a lack of elementary but precise design analysis methods. Those used by some masters of daylighting like Alvar Aalto, Le Corbusier or Aldo van Eyck were mostly individually developed and proven,⁷ without using complicated light calculations to verify their designs. Instead, large-scale models were used to visually assess daylighting strategies. Today, in times of computerization (as a example: Virtual Vision 3D programs are available for architects in Japan and some European countries, allowing analysis of some aspects of architectural design in 1:1 scale) daylight design lacks precise but simple analytical methods. They are available in the form of significantly complicated graphic tables and specific diagrams. These methods help, however they do not provide the combination of accuracy and reliability which are so important for daylight design. Architects should approach most of them with caution because daylight is a visual phenomenon and cannot be fully captured and framed in restrictive tables under scientifically provided guidelines.⁸

7. Plummer, Henry, "Poetics of Light: A+U Architecture and Urbanism " Extra Edition, December 1987.

8. idea from: Kohler, Walter, Chapter "Light as Phenomenon" from "Lighting in Architecture," Reinhold Publishing Corporation, 1959.

The daylighting techniques used to allow light to penetrate spaces in a controlled manner should be responsive to many factors. They should deal with direct solar radiation as well as reflected light from landscape, surrounding buildings and trees. Skydome illumination is another problem that should not be left behind. The amount of daylight received from the skydome depends on the position of the sun and on atmospheric conditions. It also depends on dust, haze and air pollution.⁹

Three basic light conditions are widely recognized in the field of daylighting. They have the significant impact on daylight design:

1. direct sunlight and clear sky conditions
2. clear sky light
3. light from the overcast sky

They should be taken seriously under consideration, together with already mentioned atmospheric conditions, geographical position, and building orientation, as starting points for every daylighting design.¹⁰ While it is often misleading, it is generally considered that for daylighting purposes, the bigger the window, the better.

9. "Daylighting," American Institute of Architects.

10. "International Daylighting Conference, 1986," McLean, VA, 1986, International Daylighting Organizing Committee.

CENTRAL FENESTRATION ORIENTED E-W

DIFFUSE HORIZONTAL SKYLIGHT

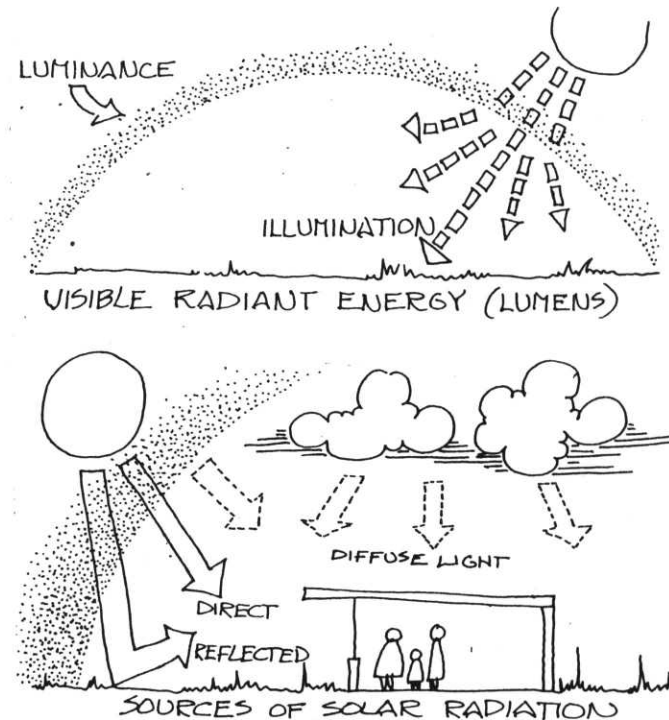
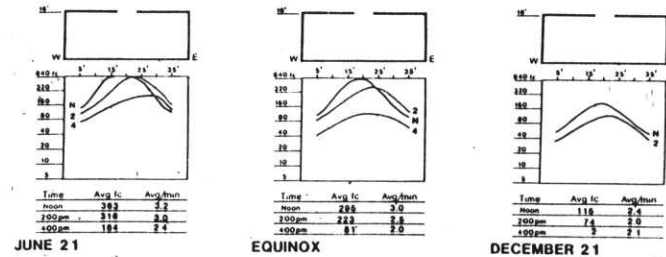

It is also considered that the design is better if the windows are placed higher in the wall of a space with a high ceiling. Horizontal openings are usually better than vertical ones because they do not create undesirable strong patterns of light and dark contrast. Some fixed daylight control can be designed if the building orientation is as close to north-south as possible.¹

Sidelighting is a commonly used daylighting technique. Typically, this method uses diffuse radiation only, mostly in buildings where passive solar heating is not planned. In such cases direct sunlight is required.²

It seems to me that besides selecting the best daylighting techniques many methods and fixed controls combined together in one design may be confusing and not spatially clear, therefore, it is advised to select one strong central theme of how the spaces are going to be provided with light. As William M.C. Lam in his book, "Sunlighting as Formgiver for Architects" says: *"one should realize that building character and program should be in harmony with the chosen daylighting methods."*

1. information from: Egan, David M., "Concepts in Architectural Lighting," New York, McGraw-Hill, 1983.

2. Rosen, James E., "Natural Daylighting and Energy Conservation," M.I.T Thesis, 1981.

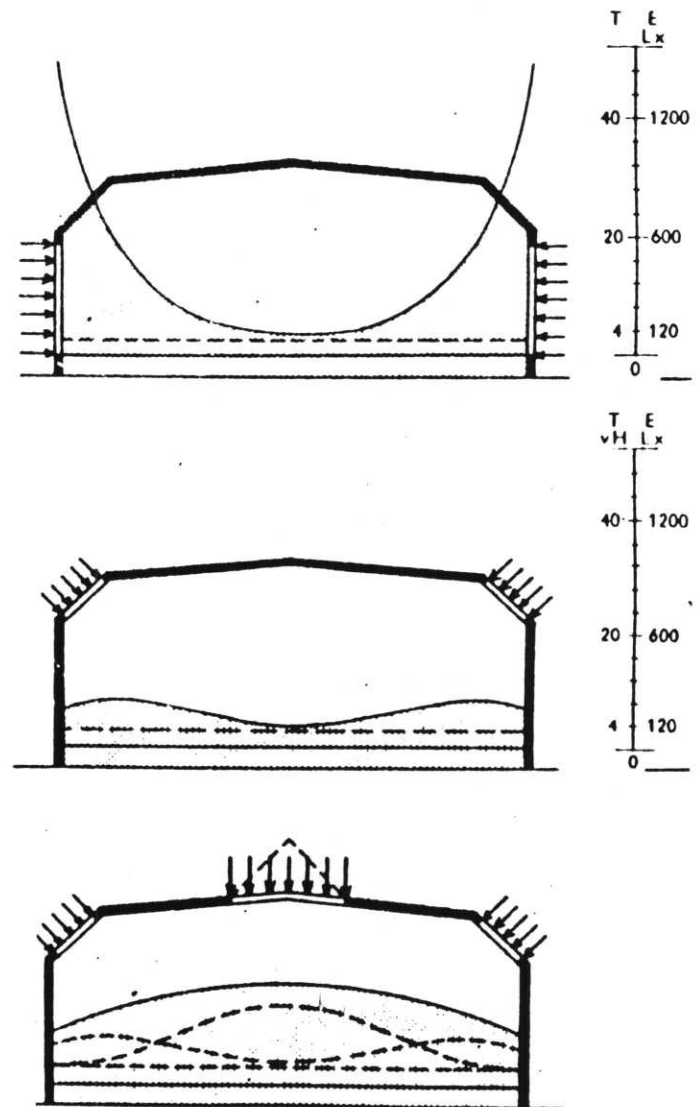

Below are several basic principles of how the daylight should be admitted into the spaces and how it should be distributed to the best benefit of daylighting design:

A. Admitting daylight through high openings that are close to the ceiling where window height is about half of the room length is considered proper (directing the sunlight or heat loss is another, technical issue).

B. Clear-glazed interior partitions should be used near the ceiling, so that light can penetrate deep into the space.

C. Avoid large amounts of direct sunlight inside offices, schools, museums, hospitals and library spaces.

D. Provide rooms with time orientation in order to allow for visual contact with the outside environment.

E. Avoid cornered openings. These may increase the brightness ratios inside the room over the required level.

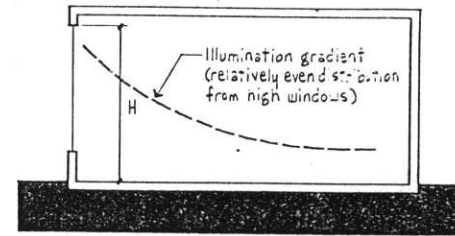

High Openings

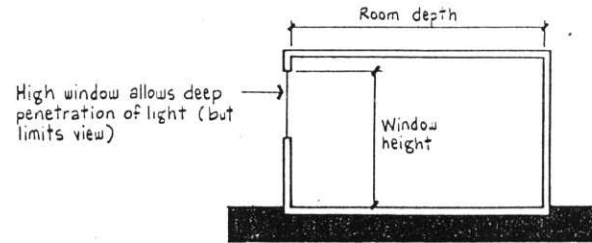

Low Openings

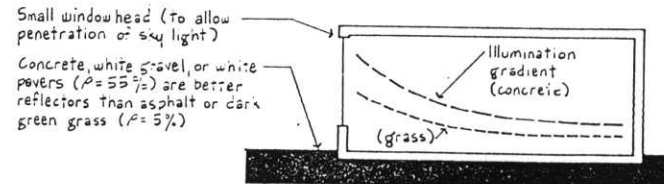
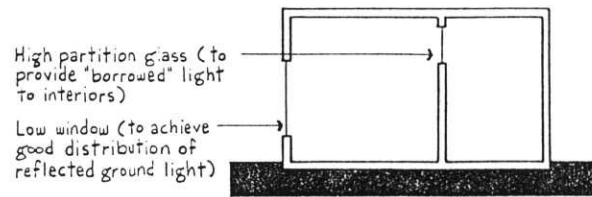

Text reference for A-W:

Lam, William M.C., "Sunlighting as a Formgiver for Architecture," New York, McGraw-Hill, 1990.

Egan, David M., "Concepts in Architectural Lighting," New York, McGraw-Hill, 1983.

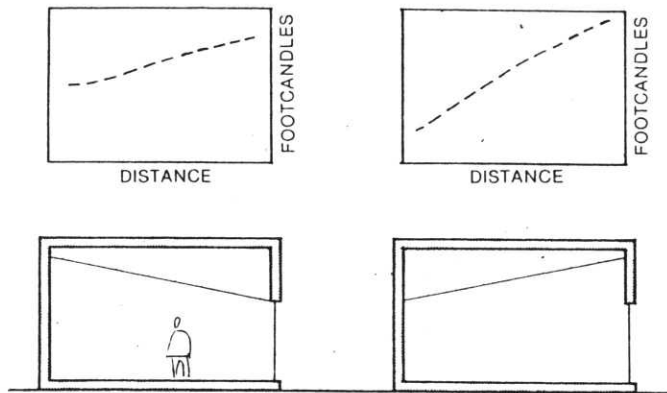

F. Admitting daylight from more than one opening is strongly recommended, especially in office spaces.

G. Avoid applying dark-colored wall finishes around the windows; this may create undesired optical contrasts.

H. Use ceilings to redirect light in long, deep rooms; the higher the ceiling, the more steady the illumination.

I. Try to reduce the illumination near windows by placing glazed openings closer to the floor and increasing vertical room dimensions.

J. In deep spaces use sloped ceilings instead of flat ones.

K. Use beams perpendicular to the window, in order to achieve better, diffused and uniform light inside the room.

L. Avoid glare and reflections by using dark-colored ceilings near the window; bright colors are required further in.

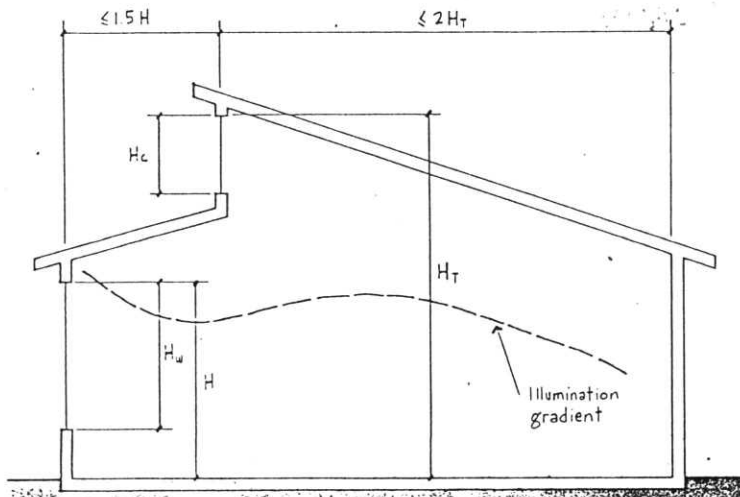

M. For overcast conditions, the upper windows provide rooms with the best illumination.

N. Avoid low windows in shadowed areas.

O. Use reflectors (double sloped ceilings, sloped shelves) to reflect daylight into the spaces.

P. The best devices for daylighting purposes are lightshelves and high ceilings (these can be used in public spaces).

R. The building's North-South orientation is the most useful for daylight design purposes.

Q. Use traditional fixed exterior daylighting controls, such as lightshelves and overhangs, which may enrich building facades and give additional character to the created design. What is important - these controls do not need constant maintenance as well.

S. Use horizontal skylights for overcast sky conditions.

Short Cantilever

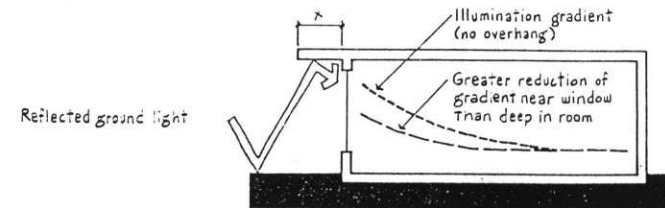

Wide Cantilever

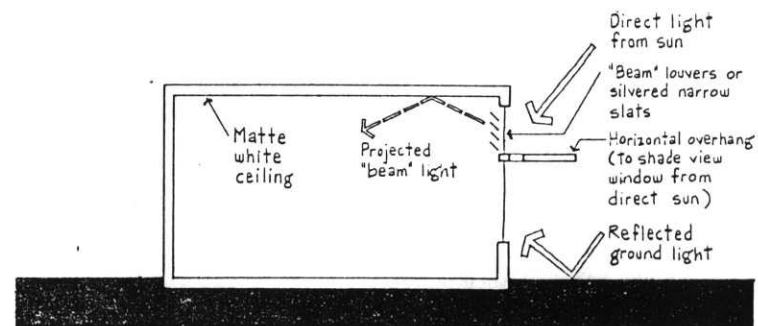
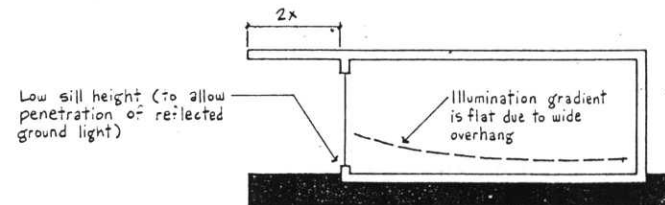

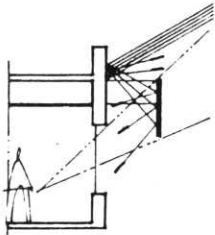

"Suncatcher" baffles block direct sunlight but allow maximum indirect reflected sunlight.

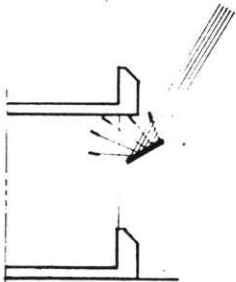

Sloping the lightshelf in directs light inside building but does not shade as effectively.

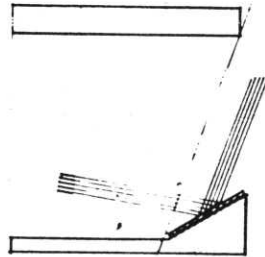

Sloped mirrored surface at the front edge of lightshelf reflects high-angle summer sun deep into space and makes the most efficient use of the smaller band of sunlight reaching the lightshelf in summer.

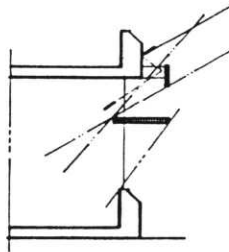

The lightshelf can be combined with a vertical baffle for additional shading in difficult conditions, such as east/west orientations.

T. Avoid designing rooms where the depth is more than 2.5 times their height (for effective light distribution).

U. Light admitted by Litrium should always be directed towards the bright-colored ceiling and then diffused from it towards the floor.

V. Use prismatic glass block (instead of horizontal louvers) above the overhangs to direct sunlight towards a reflecting ceiling.

W. Avoid using low-transmittance glass (tinted glass) in windows and doors below eye level. Otherwise, the outdoor time orientation may be drastically limited.

Text reference for A-W:

Lam, William M.C., "Sunlighting as a Formgiver for Architecture," New York, McGraw-Hill, 1990.

Egan, David M., "Concepts in Architectural Lighting," New York, McGraw-Hill, 1983.

Models are very useful for predicting both the quality and quantity of daylight and can reveal lighting gradients, specific glare problems, and the effects of building architectural form.

Models should be tested under natural conditions, outdoors, ideally at the proposed building site where surrounding environment reflections, shadows, and haze are important elements in obtaining correct information about daylighting. Outdoor testing suggests the limitations of real time, but the passage of seasons can be simulated by tilting the model to obtain the proper relationship to the sun. Models should be simple, as large as possible, and made of bright non-glossy materials to avoid disturbing reflections that could influence the analysis.

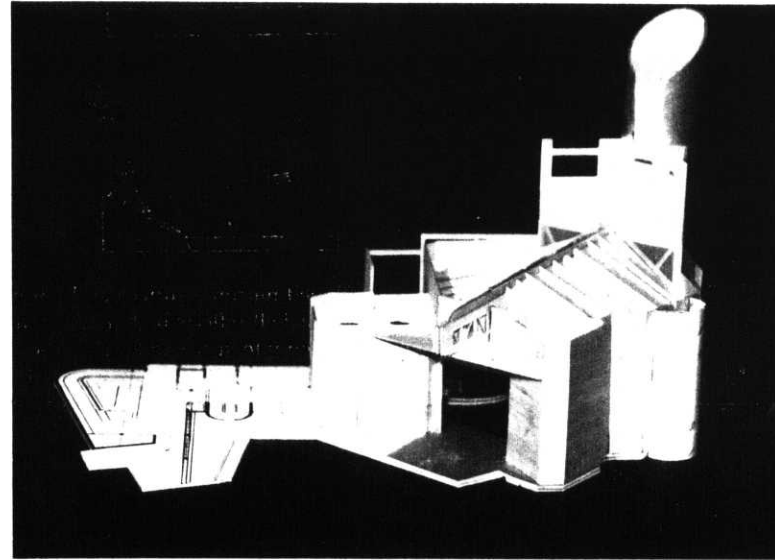

PART TWO: MASTERS OF FORM AND DAYLIGHT:

- Alvar Aalto
- Johannes Exner
- Jorn Utzon
- Le Corbusier
- Louis I.Kahn

"We were born of light. The seasons are felt through light. We only know the world as it is evoked by light, and from this comes the thought that material is spent light. To me natural light is the only light, because it has mood - it provides a ground of common agreement for man - it puts us in touch with the eternal. Natural light is the only light that makes architecture architecture."

Louis I.Kahn

Alvar Aalto, one of the best architects of this century, born and raised in Finland, knew exactly how to treasure and maximize the use of daylight. In Scandinavia, where most of his buildings were constructed, a climate zone 's difficult lighting conditions forced him to master all the possible methods and techniques of daylight control. He understood the distinction between the lighting requirements for the changing seasons of a year like no architect before him. Even though Aalto's use of light and form is not surprisingly unusual, the spaces designed by him provide carefully and properly distributed amounts of light and reveal at the same time, the beauty of the interiors. Architectural language and elements selected to achieve all of this were accurately chosen and include a variety of skylights, clerestories, screened glazed openings, vaults and lighting scoops. They are used to denote movement from place to place, and to crown or accent spaces.¹

He used baffles, polished brass, louvers, and white painted surfaces to evenly spread the most precious warm, diffused light. All these additional elements were always an integral part of his design idea and structure.²

1. Fleig, Karl, "Alvar Aalto 1922-1962," New York, Wittenborn, 1963.

2. Fleig, Karl, "Alvar Aalto 1963-1970," Praeger, 1971.

Most of Aalto's building spaces use skylights and clerestories in order to obtain natural light.³ This great architect's light manipulation ability is important on the following levels:

- His response to the environment of Scandinavian weather conditions - very long winters and short, bright summers.
- His ability to use architectural form and vocabulary to bring light into the spaces.
- His form making use of skylights to spatially model the ceiling surface.
- His use of lighting forms to mediate between inside and outside, both formally and environmentally.⁴

The ways that Alvar Aalto handled the daylight and developed a variety of architectural responses are unique in the context of Twentieth Century Architecture. The architecture of the present century has been creating larger and larger glass areas, only occasionally increasing the quality of light in dealing with the effect of the daylighting.



3. paragraph's text reference: Peter, Richard C., "*Master of Light: Alvar Aalto*," American Institute of Architects Journal, Vol.68, No.11, September 1979.

4. Peter, Richard C., "*Master of Light: Alvar Aalto*," American Institute of Architects Journal, Vol.68, No.11, September 1979.

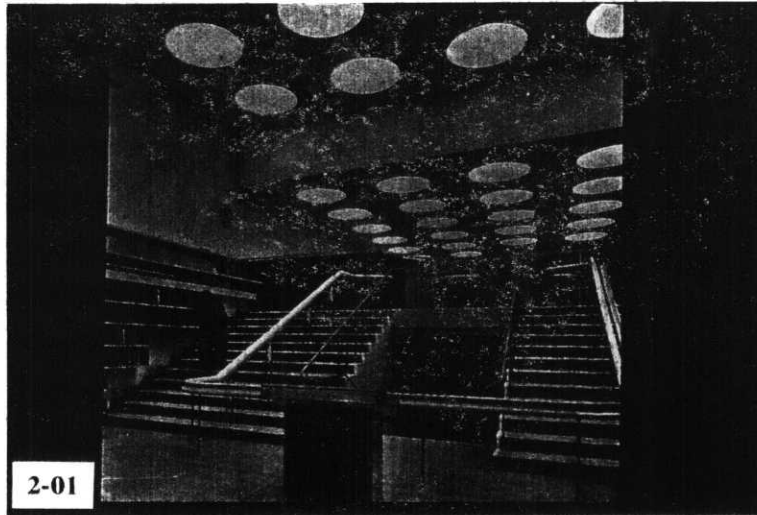

Studying Aalto's architecture, it is easy to notice that there are some variations within the theme of light, where conical skylights in the ceiling were used. The Viipuri Library reading area is an excellent example of this. Six foot deep skylights provide the space with an evenly distributed diffused light - the best type of light for reading purposes.⁶ These skylights become, along with the reading area, the major element modulating the space. The rows of round elements compositionally enliven the simple planar rendering of the walls, (2-01, 2-02).

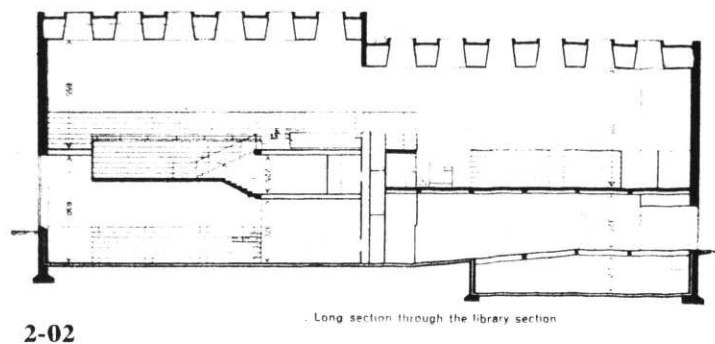

The type of a skylight presented here was repeated in the public space of Rautatalo Building, the Pentions Institute Library, the display area in the central Finnish Museum in Jyvaskyla and the foyer in the main building of the Technical Institute.⁷ Additionally, Aalto provides skylights with an artificial light source that brings light inside the spaces and melts the snow on the skylights during the rough Scandinavian winter days, (2-03, 2-04).

The library in the Wolsburg Cultural Center provides a good example of further evolution of the Viipuri-like type of ceiling. Skylights used by Aalto in this building are

6. Moore, Fuller, "Daylighting: Six Aalto Libraries," AIA Journal, Vol.72, No.6, June 1983.

7. Peter, Richard C., "Master of Light: Alvar Aalto," American Institute of Architects Journal, Vol.68, No.11, September 1979.

both conical and linear, to unify, reinforce and articulate the structure, shelving arrangements, and the reading area. These skylights help to define the particulars of the space, (2-05, 2-06).

The second variation of how light can be brought and diffused into the interior of the space can be observed in the main auditorium of the Otaniemi Technical Institute. Here the light is diffused throughout the space by large curved panels, which simultaneously shield direct light from the audience. The photograph of the auditorium indicates the resulting synthesis of skylight, structure, space, and form. It is worth noticing that the surface of the ceiling became the major element modulating the space, (2-07).

The Parish Center in Riola (Santa Maria di Assunta, 1975-78, Bologna) is designed with the same concept of bringing and diffusing the light, to this one in lecture hall of Otaniemi Technical Institute. In Santa Maria, Alvar Aalto uses relatively simple means to moderate and transform the light, which is fan-shaped and narrows near the main altar.⁸ The tapering from East to West is reinforced in section by a series of rounded concrete

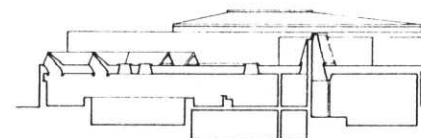
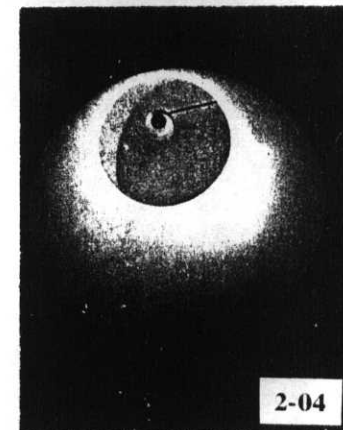

⁸Peter, Richard C., "Master of Light: Alvar Aalto," American Institute of Architects Journal, Vol.68, No.11, September 1979.

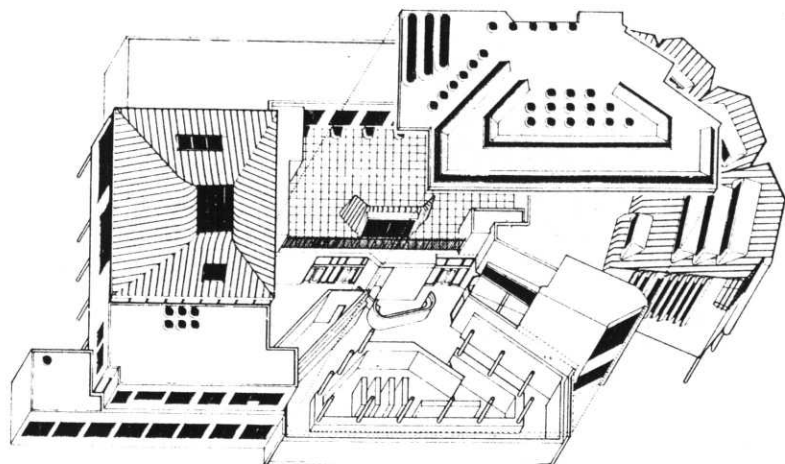

2-05

2-06



arches that repeat in gradually smaller sizes toward the altar. The main and strongest light is brought inside through a series of curved monitors that run along the church axes. These monitors allow light to filter down through the structure. There are some openings in the north elevation that start as high clerestory windows in the large West end and disappear in the middle of the elevation and then reappear as tall thin glazed openings between the series of fins. This establishes a light-dark alternation from the seating area to the altar space. On the right side of the main altar there is a small chapel adjoining the church on the north side of the altar directly opposite the main entry. This space is lighted by a large skylight, which is located so that it receives direct sunlight. This provides a warm and bright glow, in sharp contrast with the cool and gray diffused light in the rest of the church, (2-08 through 2-12).⁸

A similar form of a skylight appears, on a modest scale, in the Seinajoki Town Hall and the meeting room in the Wolsburg Cultural Center. These examples might be considered as a third variation of light manipulation by Aalto. In this case, light enters the clerestories high in the

8. Peter, Richard C., "Master of Light: Alvar Aalto," American Institute of Architects Journal, Vol.68, No.11, September 1979.

wall plane of a space, then it is diffused or directed by a curved ceiling plane. Here, there is more intense manipulation of the ceiling for both spatial and lighting purposes, (2-13).

Otaniemi's main library, one of the largest designed by Aalto, provides the light from the two large monitors and by many long, horizontally glazed skylights, (2-14, 2-15).

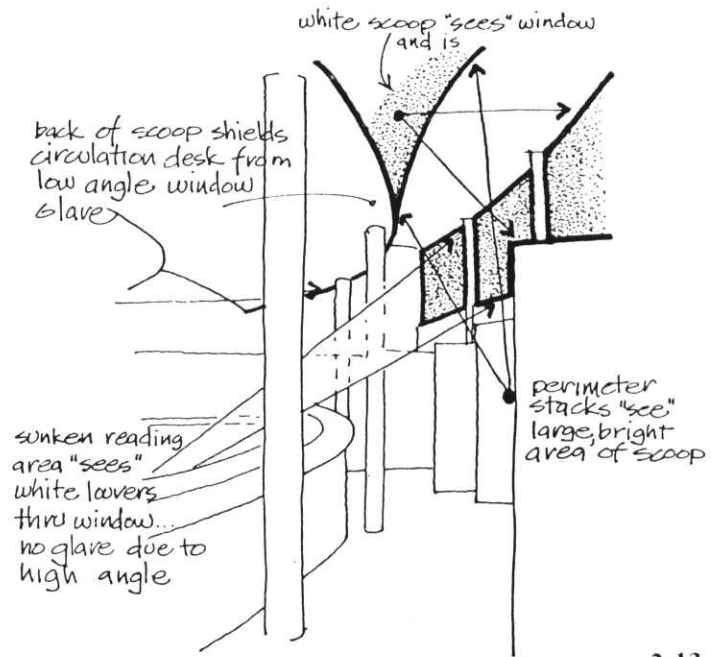

2-13

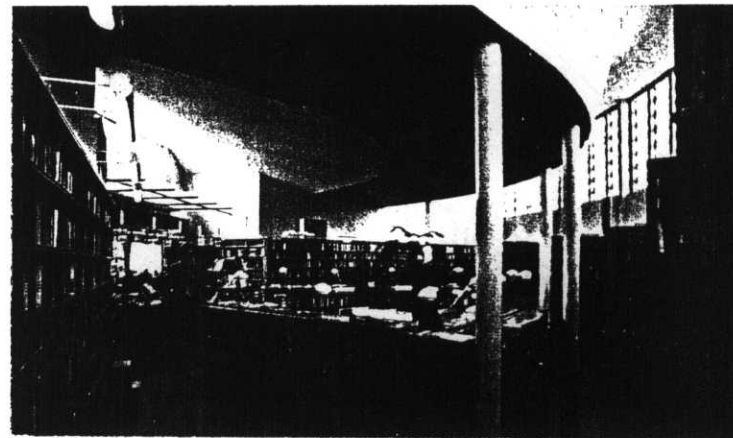

Text and drawing reference:
 Moore, Fuller, "Daylighting: Six Aalto Libraries," AIA Journal, Vol.72, No.6, June 1983.

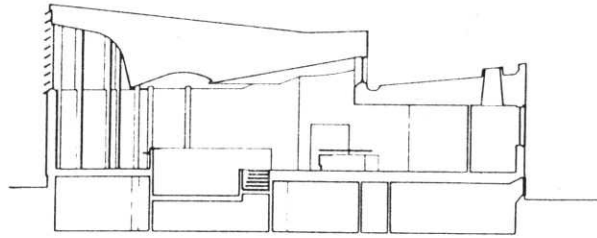

2-13

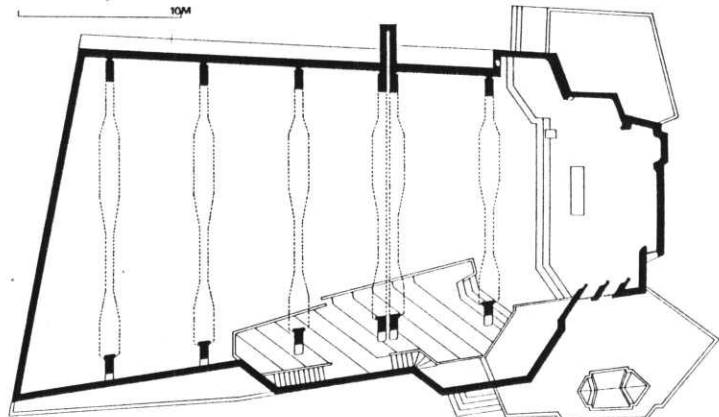
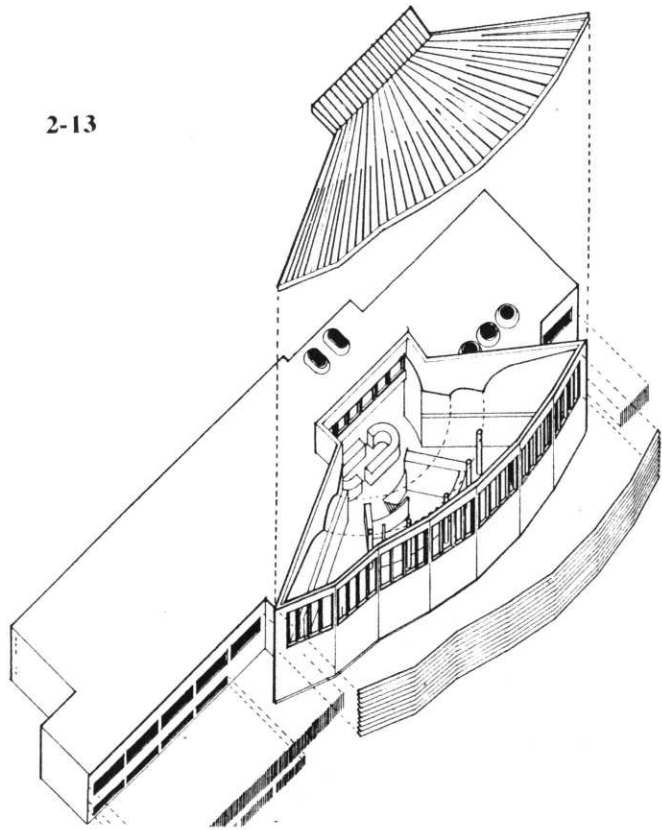

2-08

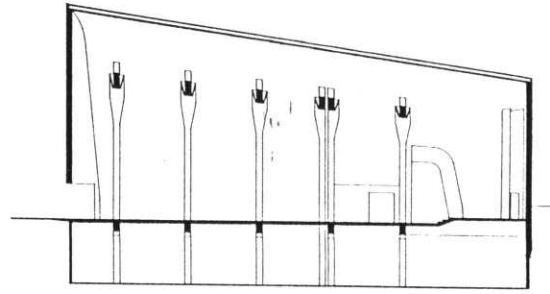
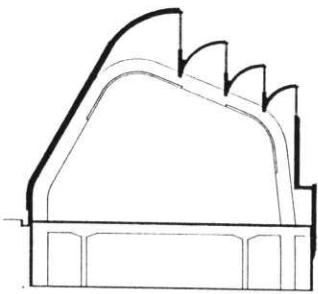
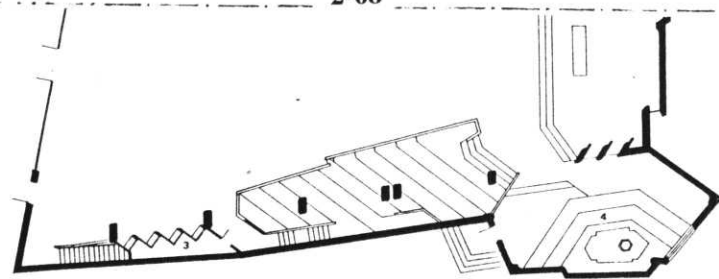

A "sees" larger sky than B
but receives less illumination
due to cosine reduction

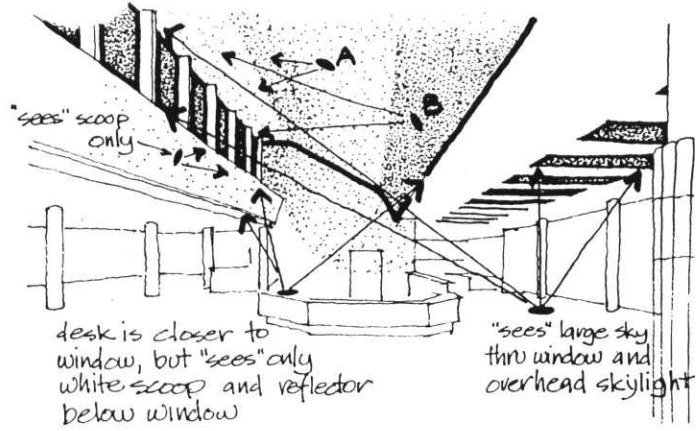

2-14

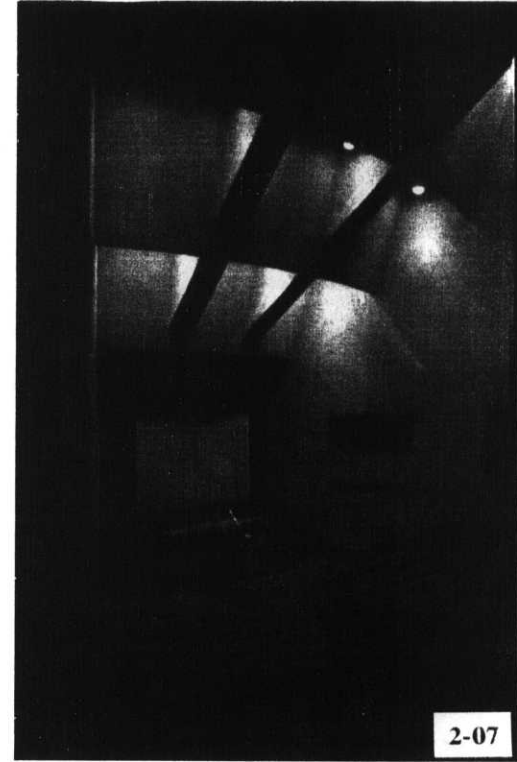
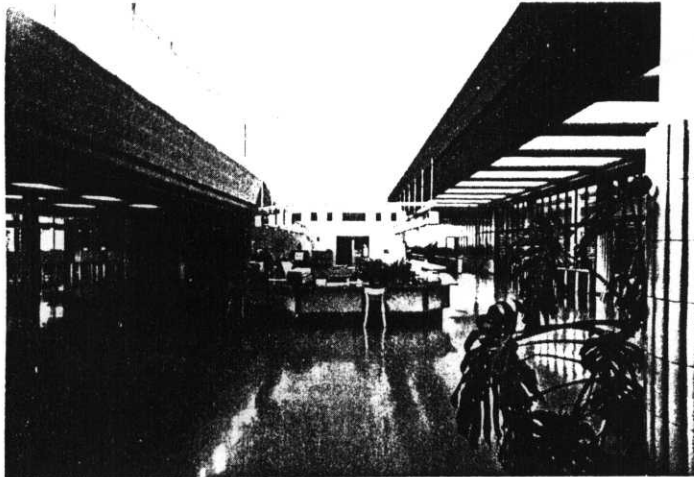

2-07

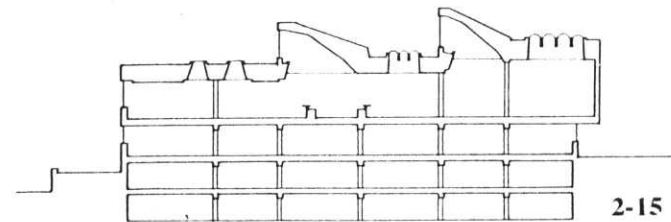

2-15

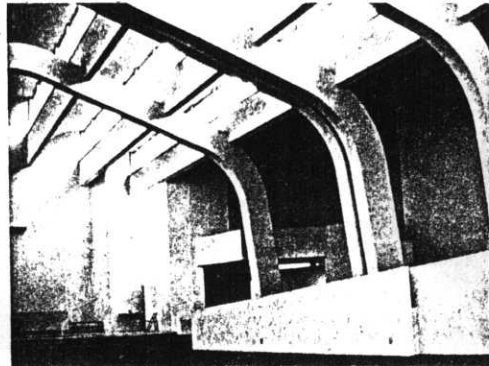
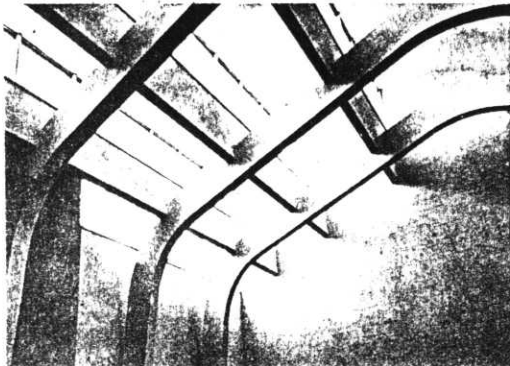
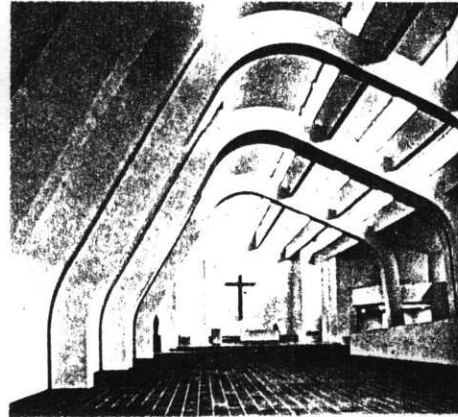
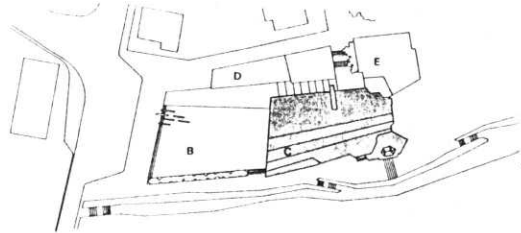
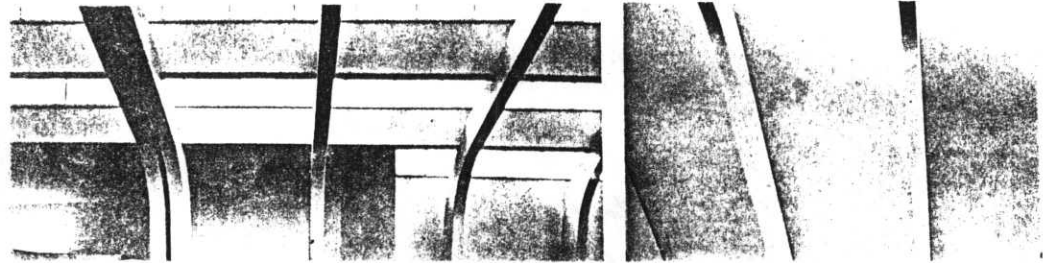
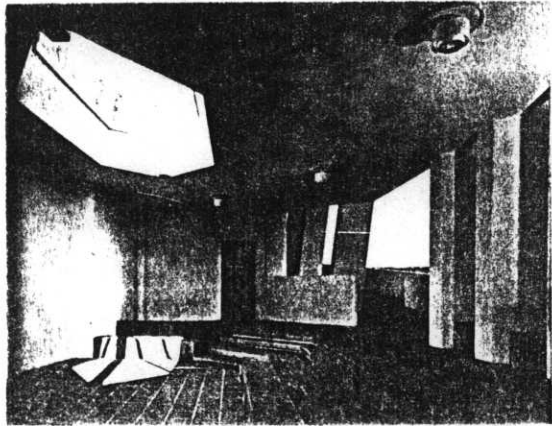

2-09 2-10 2-11 2-12

The Norre Utrup Church (Norre Sundby, Denmark) designed by Inger and Johannes Exner in 1976 represents a very modest exterior architecture which provides a visual repose in the chaotic surrounding. The interior of this church is rectangular with a curved apse behind the main altar, (2-16).⁹

Architects have paid careful attention to the natural light in the large church interior. Here, an indirect light is employed through high slits in the wall and a direct type of light through the large window above the entrance. The apse behind the altar is almost perfectly illuminated by a large skylight. It is worth mentioning that both indirect and direct lights are used in such a way as to eliminate glare.

Direct light shines diagonally into the room from the large window above the entrance (by the steeple), though without directly illuminating the altar. However, the altar remains the center of the room due to light filtering down in the apse. The church interior also receives side light from two ceiling-high slits in the brickwork.

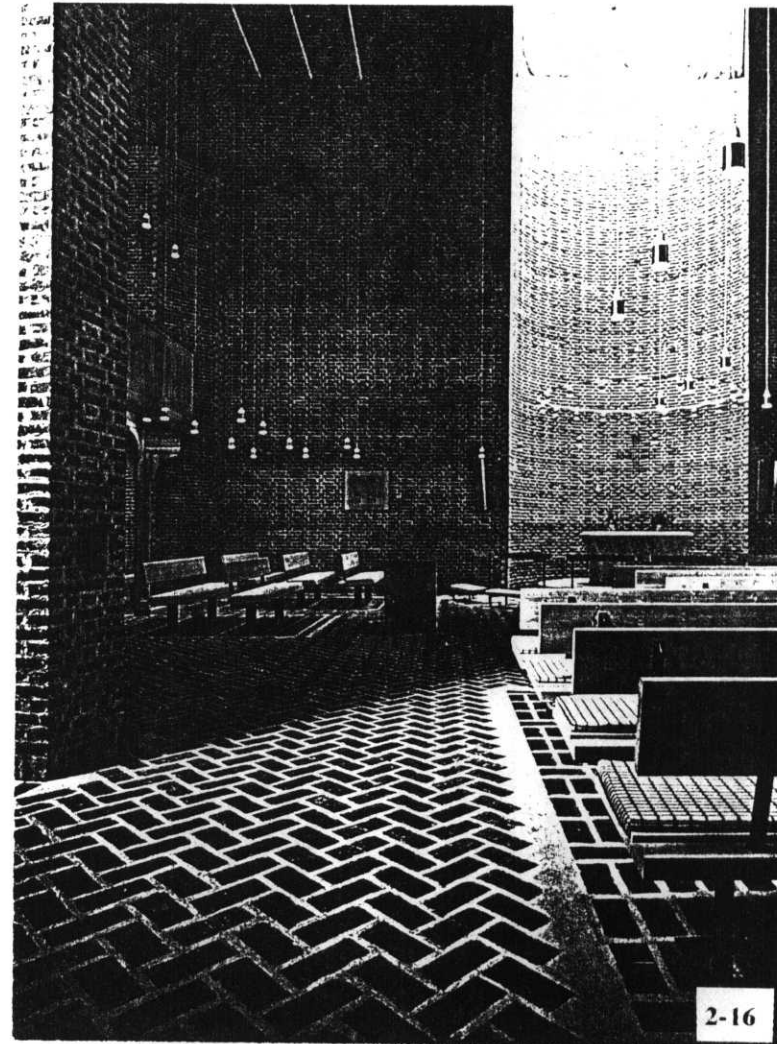

9. text and photo reference: "Arkitektur DK", 1977-79 (?).

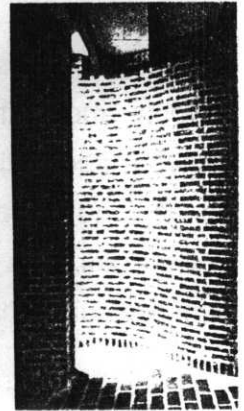
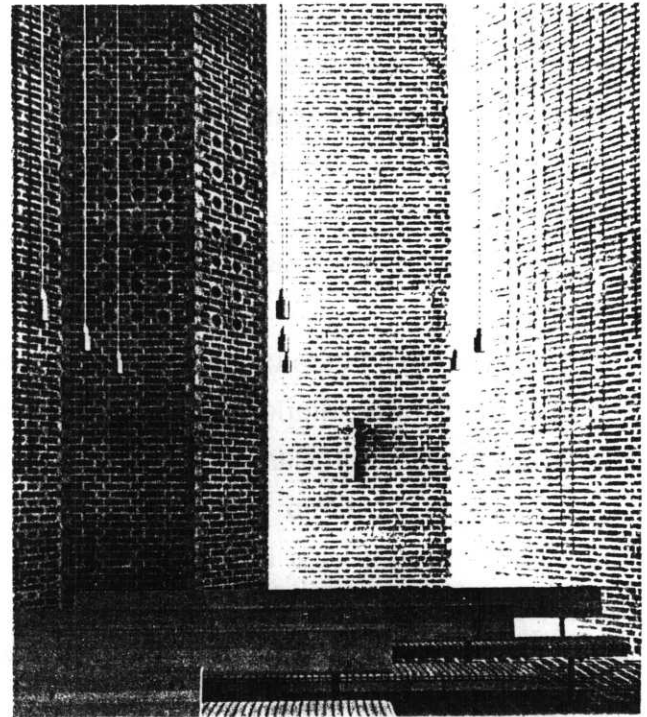
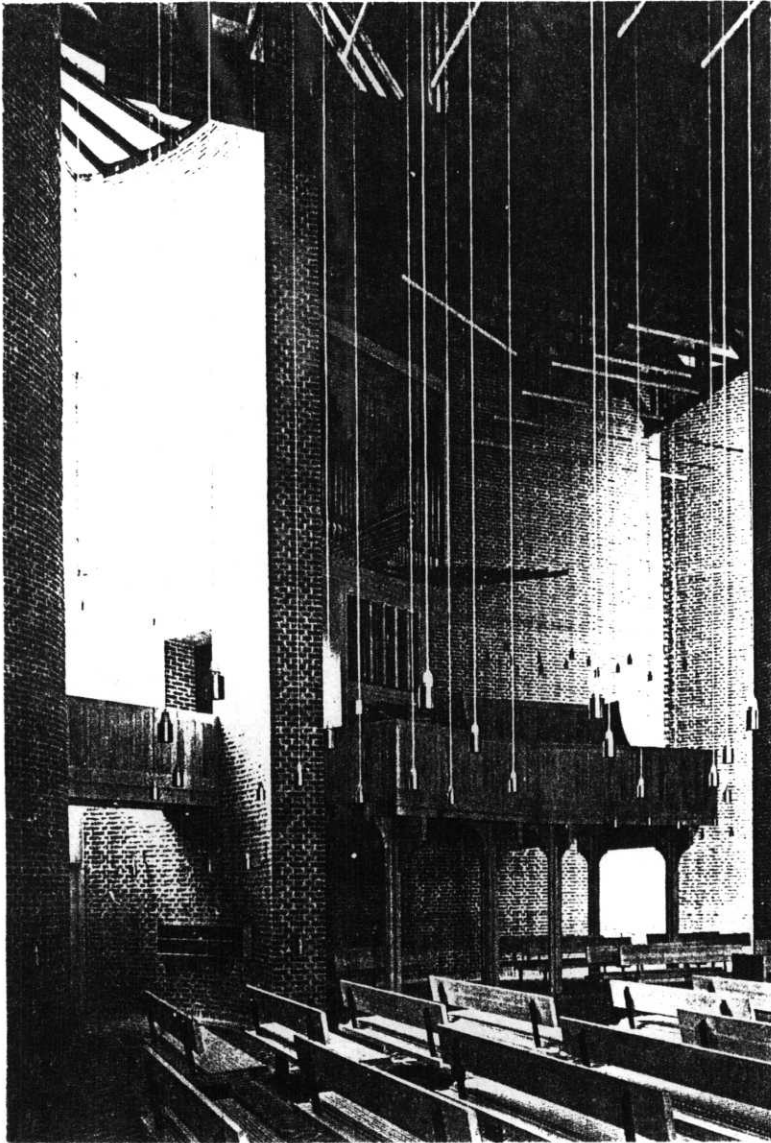

Because I am so impressed by the Exners' way of dealing with daylight inside the spaces, I would like to present one more example of their design, Saedden Church, completed in 1978, also in Denmark. Saedden is located near Esbjerg, town, a newly discovered area where a number of their projects were constructed at the end of the Seventies, (2-17).¹⁰

The church is made of red brick, the same as Norre Uttrup Kirke. The church interior is a central space with the altar placed approximately in the middle. The altar rail behind the altar is distinctive. There is a very strong light above the altar that clearly defines the central place of worship. There are smaller skylights through which light is being filtered down into the space. Two of the walls in the square church are softly folded as in the M.I.T. Chapel and form small "apses". On these whimsically designed walls light is diffused, coming through the wooden structure of the ceiling. Interior artificial light consists of hundreds of electrical small bulbs, which create sky-like impression during evening liturgical celebrations, (2-18).

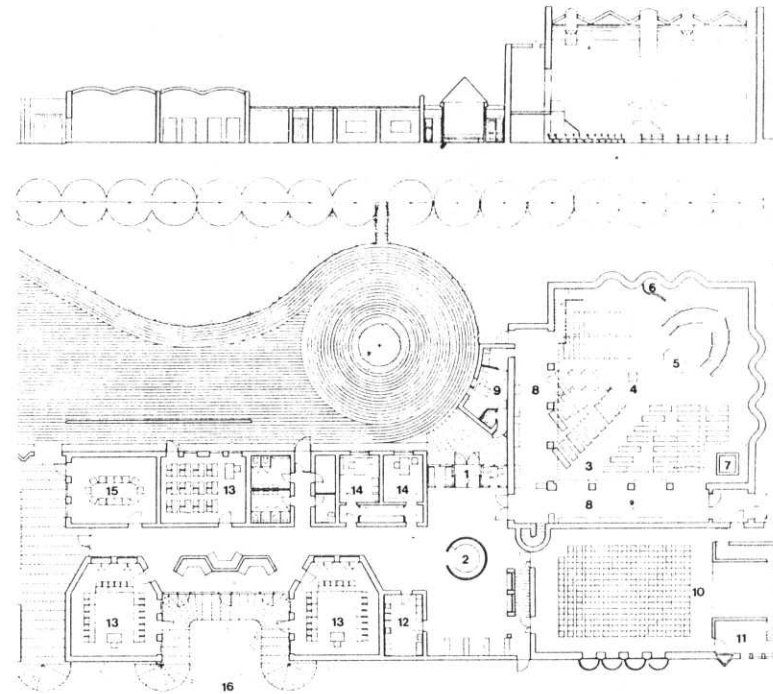

2-17 2-18

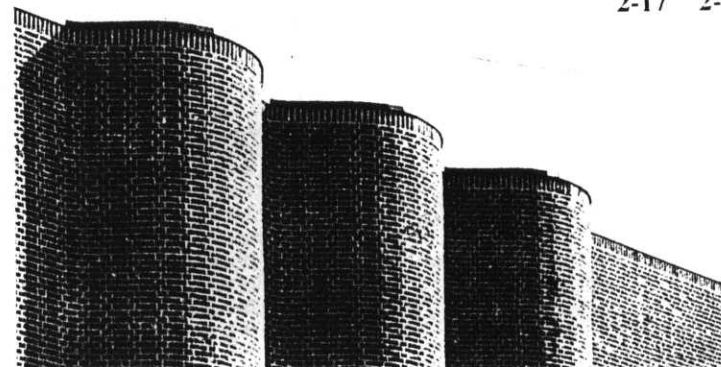

10. text and photo reference: "Arkitektur DK", 1977-79 (?).

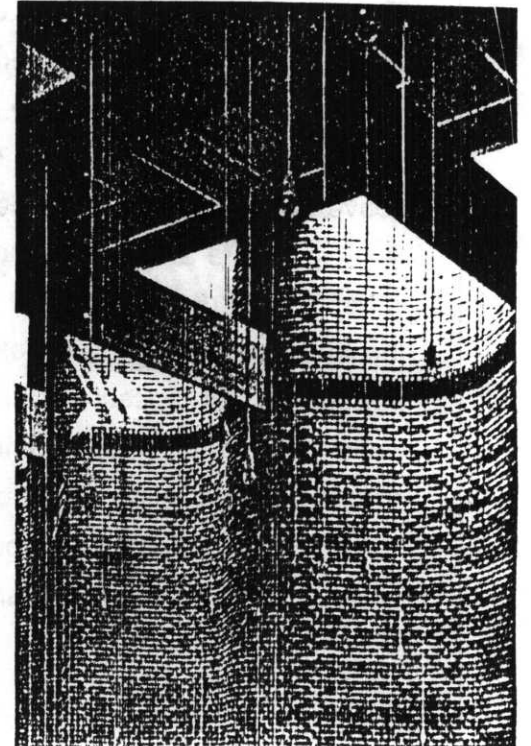
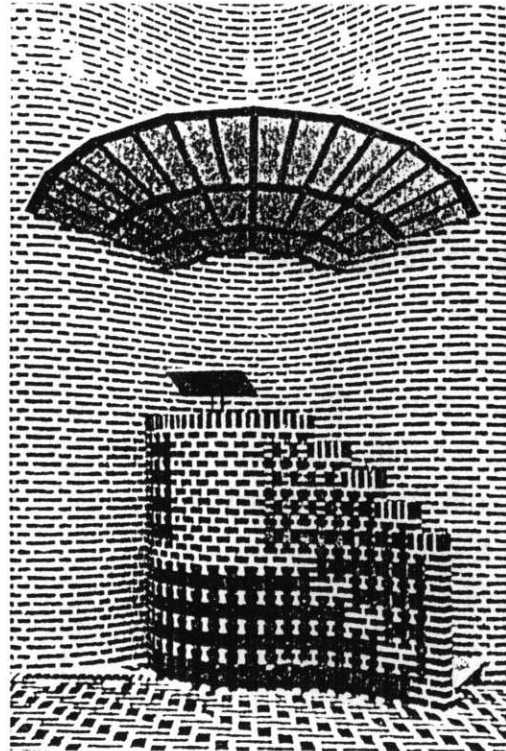
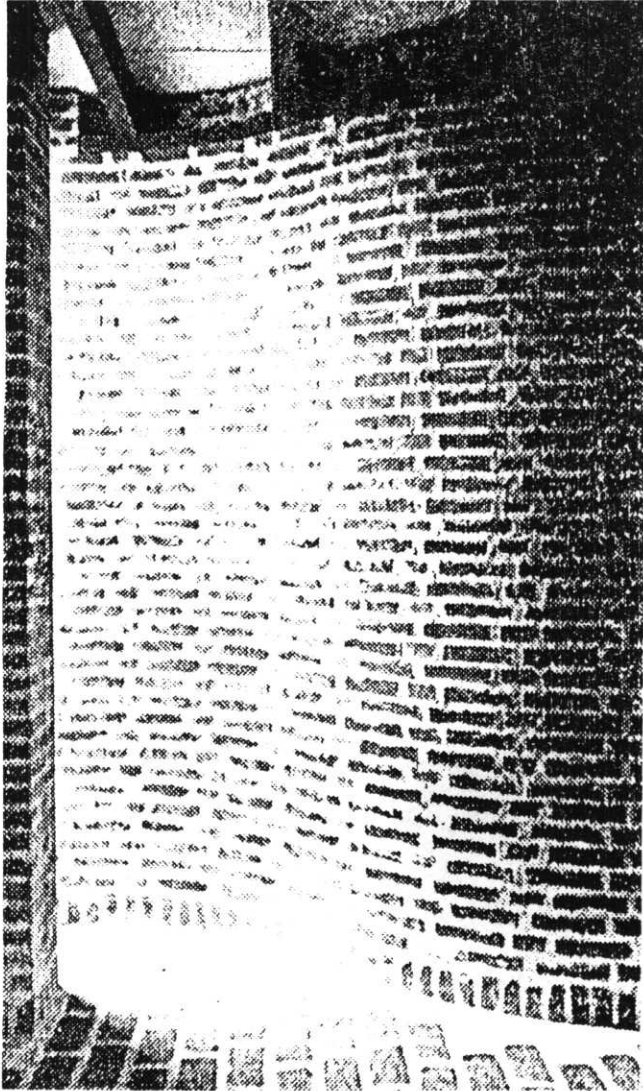

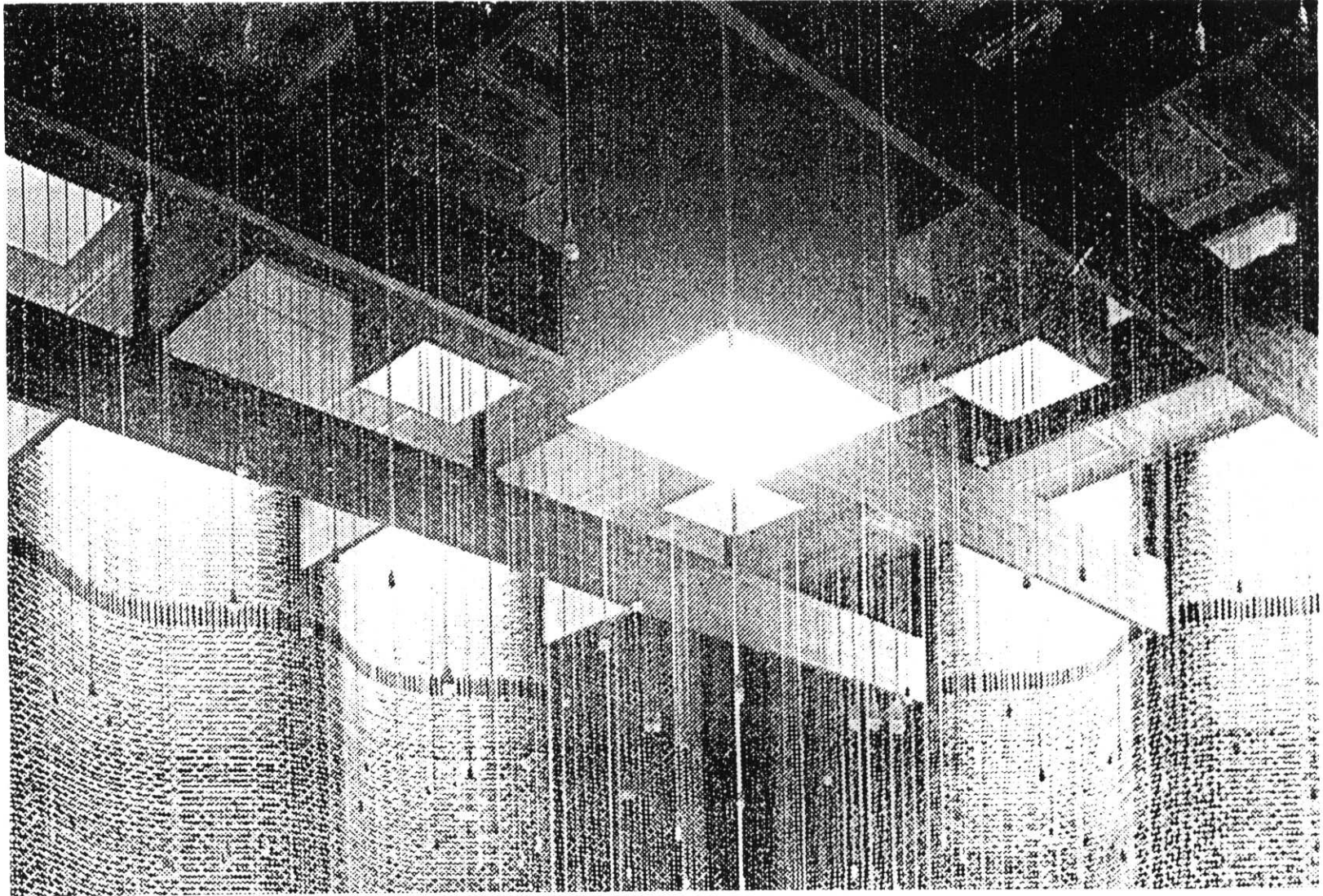

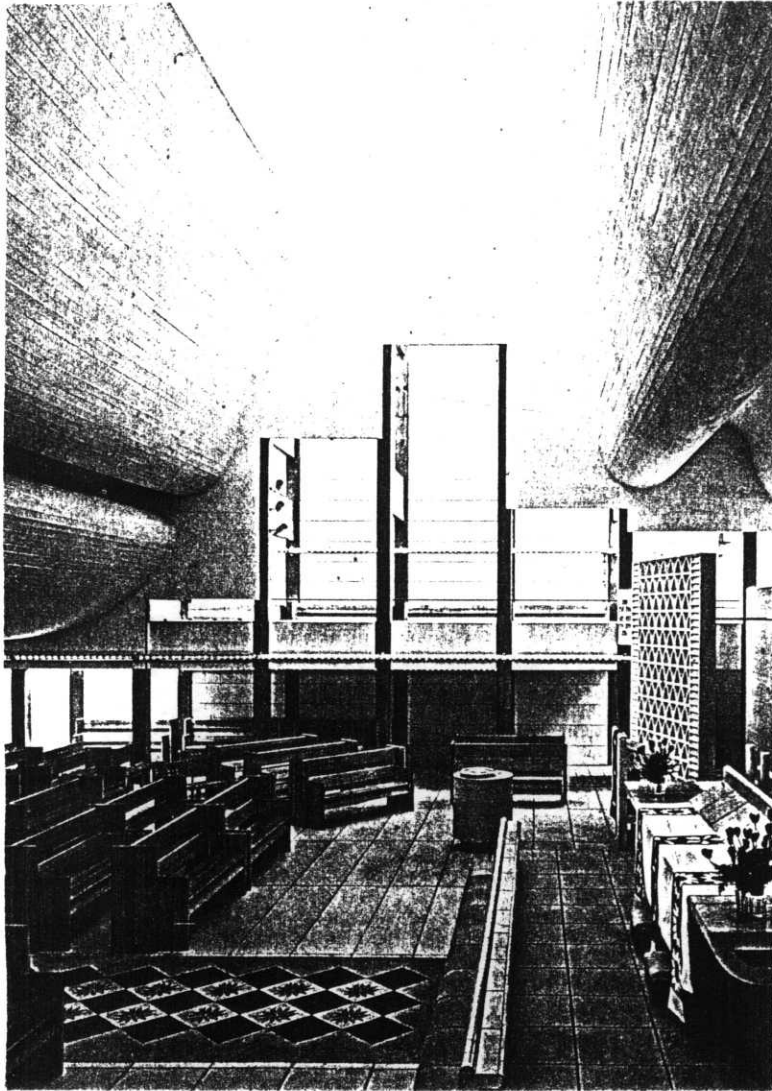

Jorn Utzon's church in Bagsvaerd, near Copenhagen, built in 1975-76 was this architect's response to a heavy brick and wood type of Danish architecture which limited incidence of daylight.¹

The church interior represents the idea of bringing diffused daylight inside the spaces. With the ceiling rising in soft cloud-like waves in a high arch, the light filters down through a slit in this cloud ceiling directly into the room. Connecting long passages are provided with a type of a skylight that offers direct light and heavenly-like atmosphere. This unusual quality is further intensified by the brightness of the materials inside the church, where white-washed brick and concrete bathe the space with soft, reflected light. Filtering down light is reinforced by the curving vaults, which distribute a uniform daylight from above designed wide skylight. In order to increase the illuminance level inside the Sanctuary's space bleached wood is used throughout in the doors, trims and pews. All these ideas and elements combine to remind one of the qualities of light beneath the clouds, (2-19).

1. from: Utzon, Jom, "Bagsvaerd Kirke," Arkitektur DK, Nyhavn, Arkitektens Forlag, March 1982.

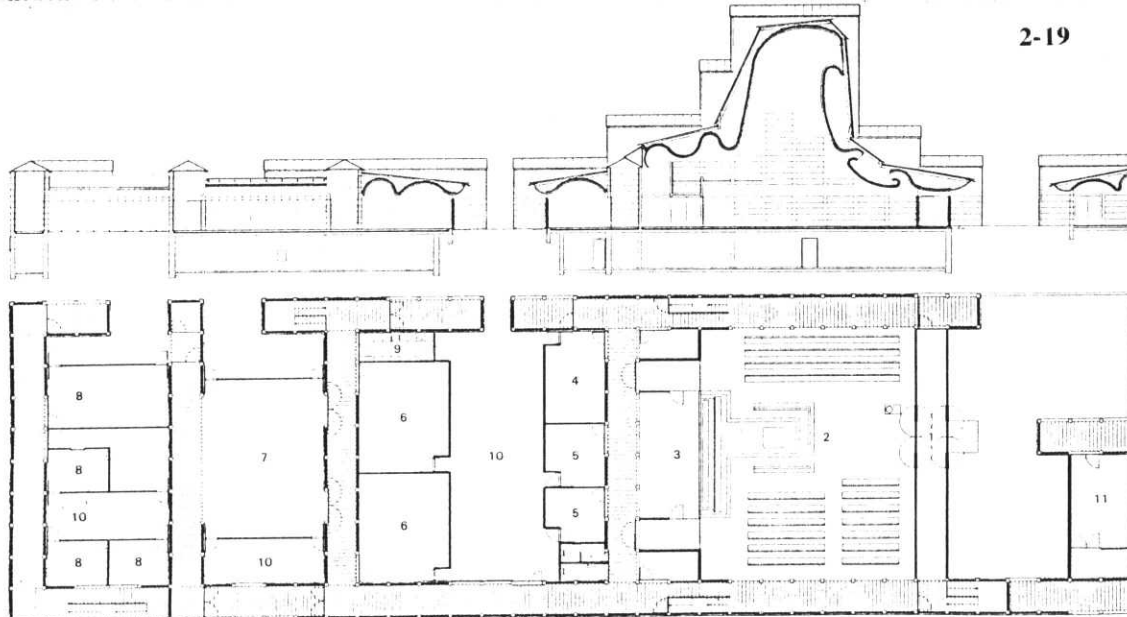
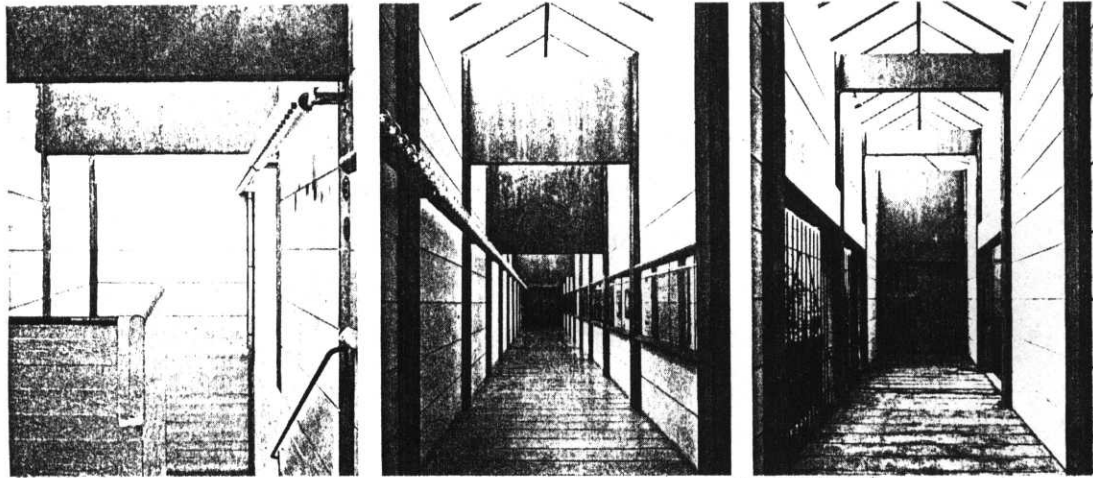

2-19

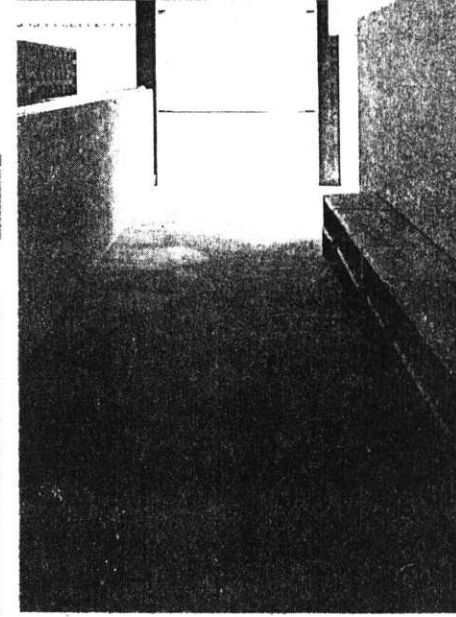

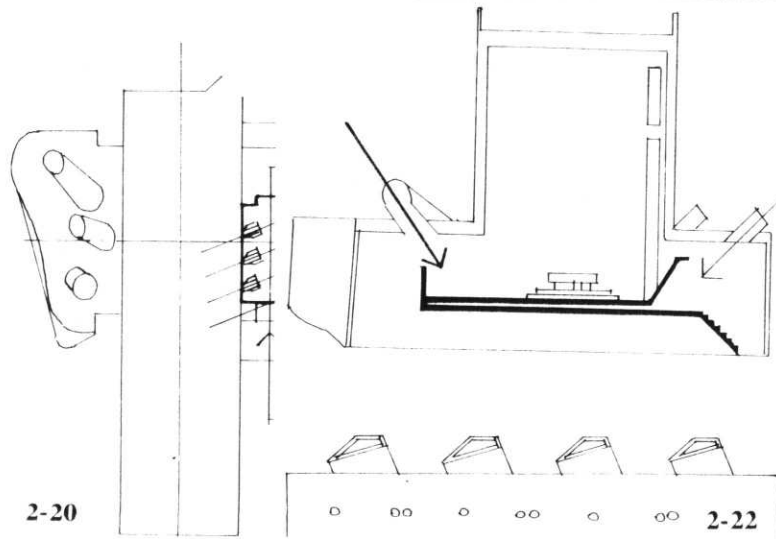
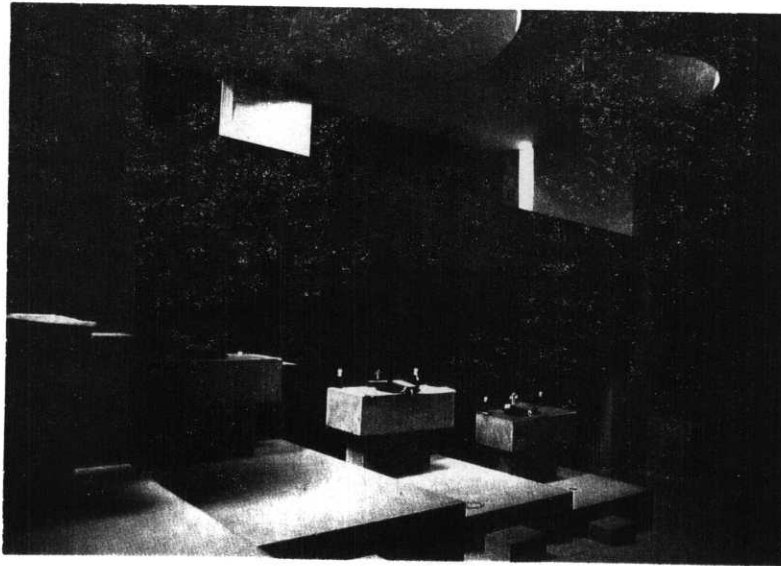

Monastery Sainte-Marie-de-la-Tourette at Eveux, France, was consecrated in 1960, but Le Corbusier started his design in 1952. La Tourette was financed by gifts, and the whole building looks rather unfinished, especially from the inside; but with so many of Corbu's buildings of this period, most of the key events in the building refer to nature and light. The church is completely enclosed, with the access of light rigidly controlled by the round skylights (see photographs) and pentagonal skylights over the sacristy called: "mitraillettes de lumiere" (machine guns of light). The latter are oriented in such a way that they project light into the nave only. The church seems to be a very silent square box. The crypt is attached to it on a lower floor. This architecturally rough space is "flooded" with light pouring in and over colorfully painted walls through the above-mentioned skylights, this time called: "cannons de lumiere", (2-20).²

The public areas are indicated by a screen of lamellas that bring direct light into the spaces, and whose rhythms of form and shadows break the very cool and simple design of this building. A very similar idea of bringing down soft and diffused light, by "cannons of light," to the

2. Baker, Geoffrey H., "Le Corbusier: An Analysis of Form," London, Van Nostrand Reinhold Co., 1984.

interiors, was used by Aldo Van Eyck in Pastoor van Arskerk Kirke. Van Eyck was definitely influenced by Le Corbusier's crypt in La Tourette. Eight round skylights, over five feet in diameter, flood the space of main church with cool indirect light, giving the ideal opportunity to offer a marriage between the earthy church space and the heavenly-like ceiling. Concrete beams, which run through the "cannons of light" in the church main space, help reflect and diffuse entering light on both sides of the surfaces. The same skylights area source of artificial light, as first used by Aalto in his libraries. Le Corbusier's and Aalto's influence on Aldo's Church, is obvious, (2-21).

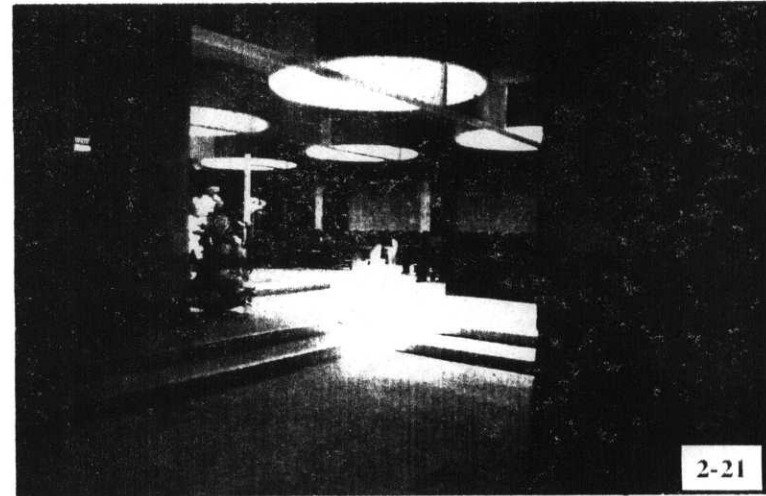

In the La Tourette Monastery, Le Corbusier directs spatial movements within the church spaces towards the sanctuary via the above mentioned three "cannons of light," providing the most powerful effect, distributing light over this main space and tabernacle altar.³ The Sacristy, located on the opposite side of the church axis is provided with diffused light by seven ceiling light sources. Each of them allows light to enter the sacristy along the same diagonal, delivering evenly distributed light inside the space, (2-22, 2-23).

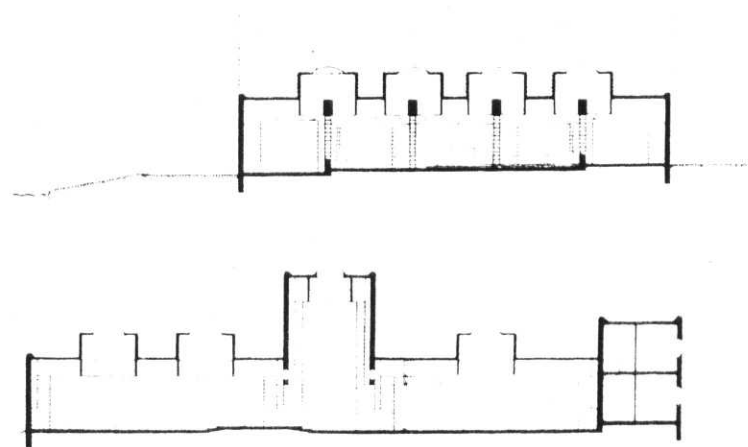

3. Baker, Geoffrey H., "Le Corbusier: An Analysis of Form," London, Van Nostrand Reinhold Co., 1984.

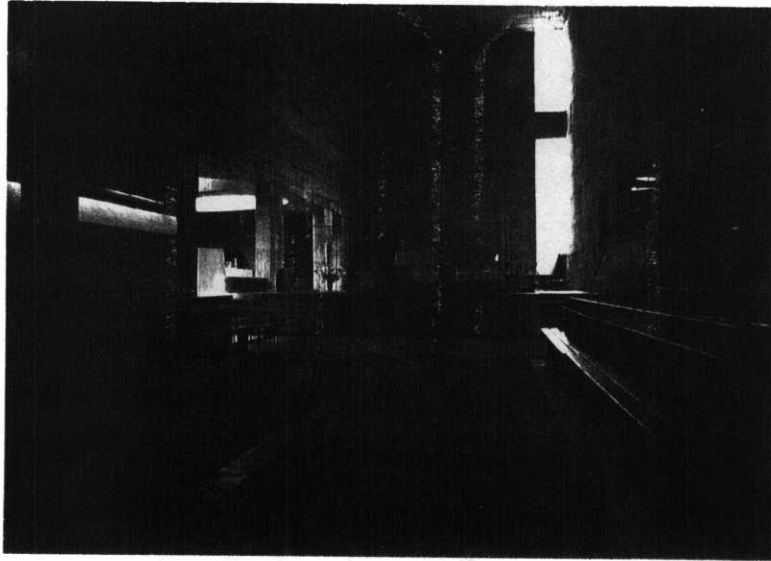

Le Corbusier's Form and Daylight use had gone through a major transformation. In his youthful, almost utopian vision, architecture operated as a light-delivery system, with light itself as the major environmental functional subject and purpose of that architecture.⁴ In the later projects, his work evolved towards the more evocative and traditional, in which light plays a decreasingly objective role. From another point of view, light in his design plays more symbolic, poetic, and even mysterious role intensifying volume, space, and architectural meaning.



The Notre-Dame-Du-Haut, Ronchamp is one of the best such examples. Here, the integration and relationship between form and daylight are strongly present in the main sanctuary space and the three small chapels. Each of them is a private enclosed space expressed by soft, curvilinear shapes defined by the light source from the towers, (2-24).

A sense of a mystery inside the Sanctuary is achieved by allowing a variety of a daylight to penetrate the space from different angles. This way created contrasts of light

4. Baker, Geoffrey H., "Le Corbusier: An Analysis of Form," London, Van Nostrand Reinhold Co., 1984.

modulating all the Sanctuary's interior spaces and forms. Here, lighting is direct. For example, small wall openings in the Altar area admit pinpoints of direct light. Powerful, direct light is admitted by a thick southern wall's rectangular, deep openings. Diffused light entering through the towers and narrow opening between the slightly raised roof and two walls is mysterious and radiant. In the north facing larger chapel, where a massive and high tower defines the main entry, the illumination during daytime is nearly constant. The smaller west and east chapels provide the interior spaces with diffused and always changing light. In contrast to this warm or cold indirect light, a flood of direct multicolored daylight is admitted by the most spectacular south wall's rectangular openings, (2-25, 2-26).

Le Corbusier about the Ronchamp Chapel:

"The shell of a crab picked up on the Long Island near New York in 1946 is lying on my drawing board. It will become the roof of the chapel: two membranes of concrete six centimeters thick and 2.26 meters apart. The shell will lie on walls of the salvaged stones

The key is light and light illuminates shapes and shapes

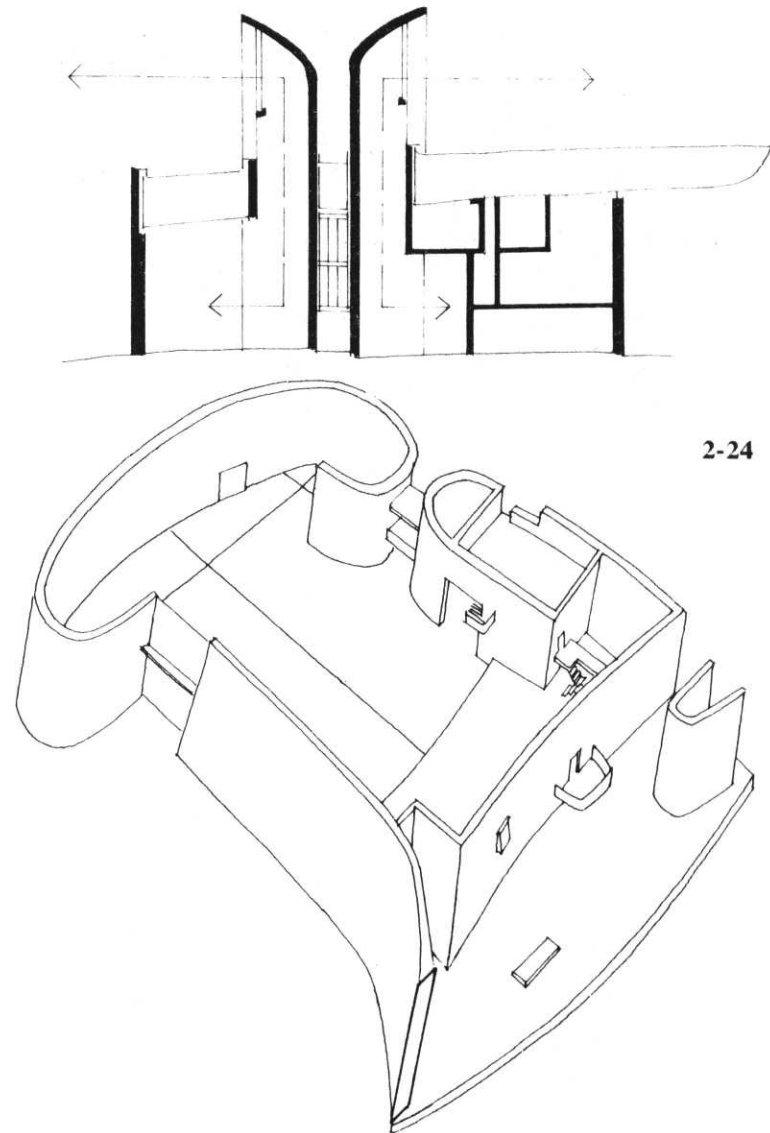

2-24

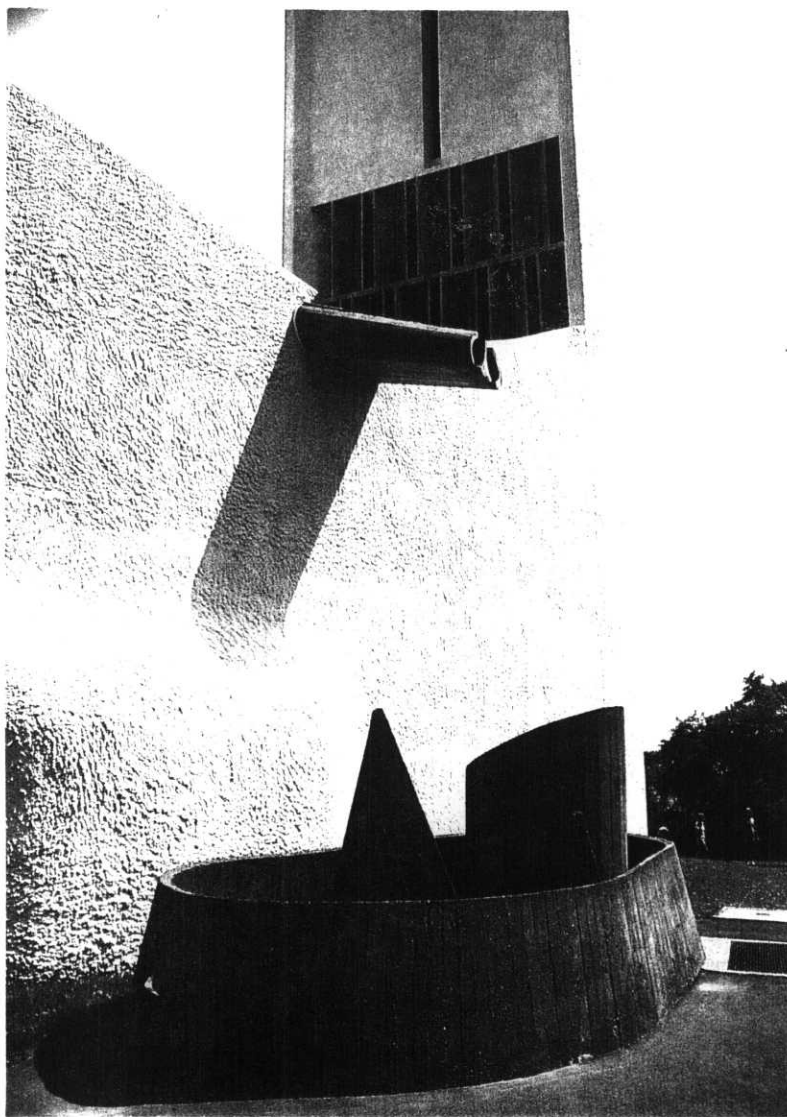

have emotional power. By the play of proportions, by the play of relationships unexpected, amazing But also by the intellectual play of purpose: their authentic origin, their capacity to endure, structure, astuteness, boldness, even temerity, the play of those vital abstractions, which are the essential qualities - the components of architecture."

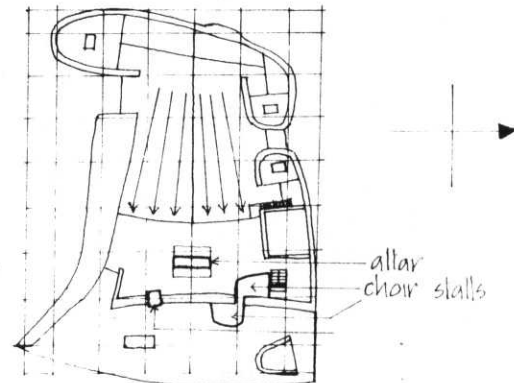
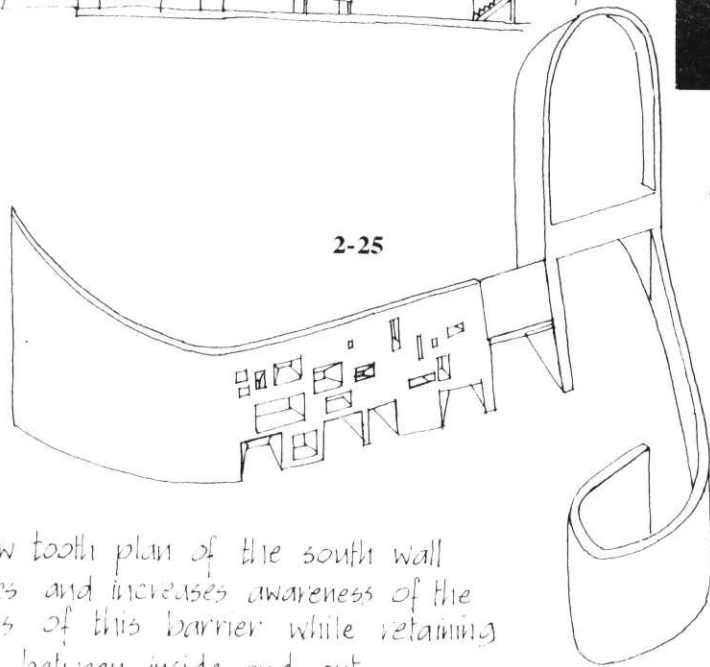
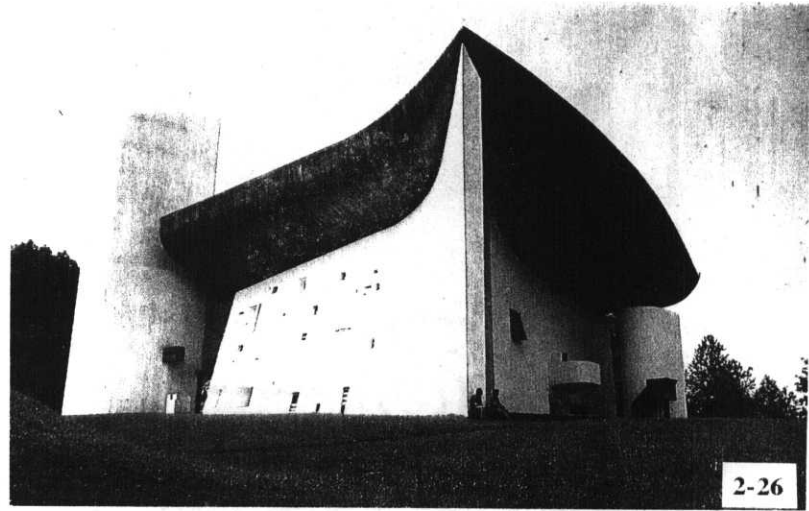
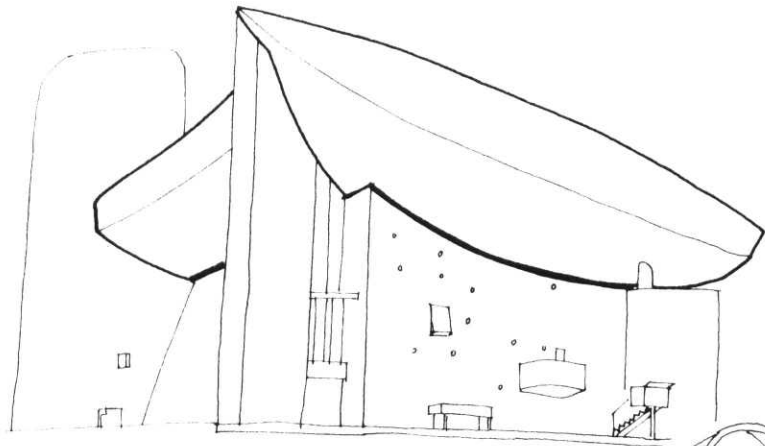

The saw tooth plan of the south wall preserves and increases awareness of the thickness of this barrier while retaining contact between inside and out.

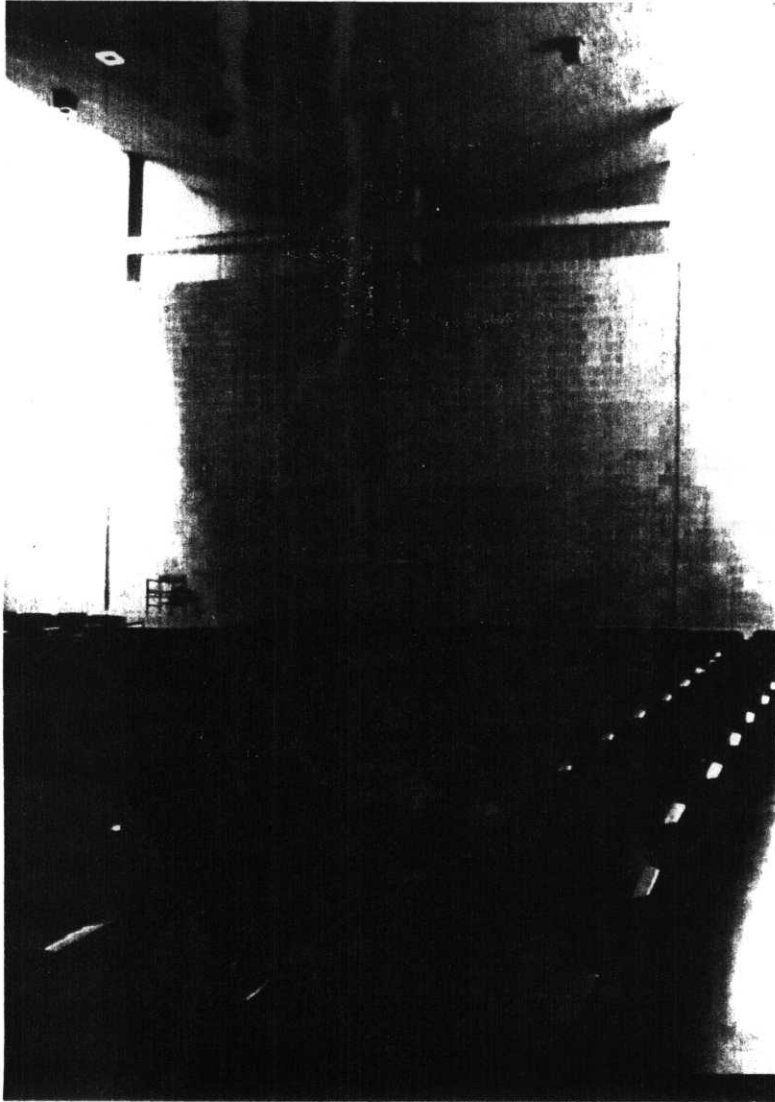

In the First Unitarian Church in Rochester, New York in 1957-64, L.I. Kahn fulfilled his own belief and theory which says that the structure of a building is the primary provider of light. Working on my thesis project, and on some previous works, I now understand how true this observation is. Examples of this motto can be found, without any difficulties, in his projects for Yale University, the Kimbell Art Museum, Phillips Exeter 's Library and the First Unitarian Church as well.

The main space of the church receives a semi-diffused light through the clerestories, which are located at the corners of a church. They provide the only source of daylight. Around the main worship space, he has designed: offices, classrooms, and a library; most of these spaces receive diffused light from the outer folded walls, (plan: 2-27).⁵

In 1967 Louis I.Kahn started his design work on the Kimbell Art Museum. His first idea of a repetitive series of shed-like structures was followed with partial success until the end. The idea of bringing light from a very rigid shape through the series of quarter circles was always clear, with or without ceiling reflectors, (2-28).⁶

5. Lobell, John, *"Between Silence and Light, Spirit in the Architecture of Louis I. Kahn,"* Shambhala, Boston, 1979.

6. Mayers, Marshalls, *"Masters of Light: Louis I.Kahn,"* AIA Journal, Vol. 68, No.11, September 1979.

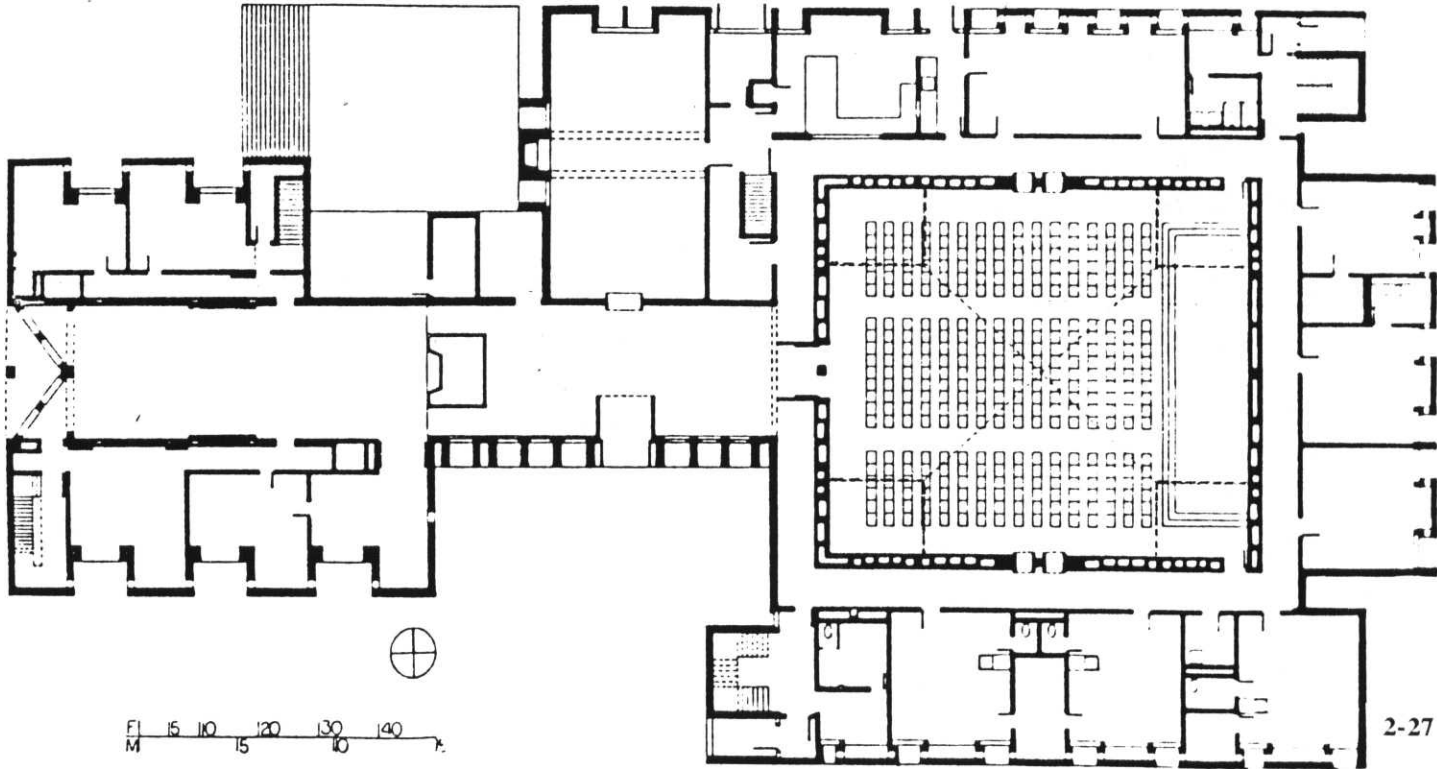
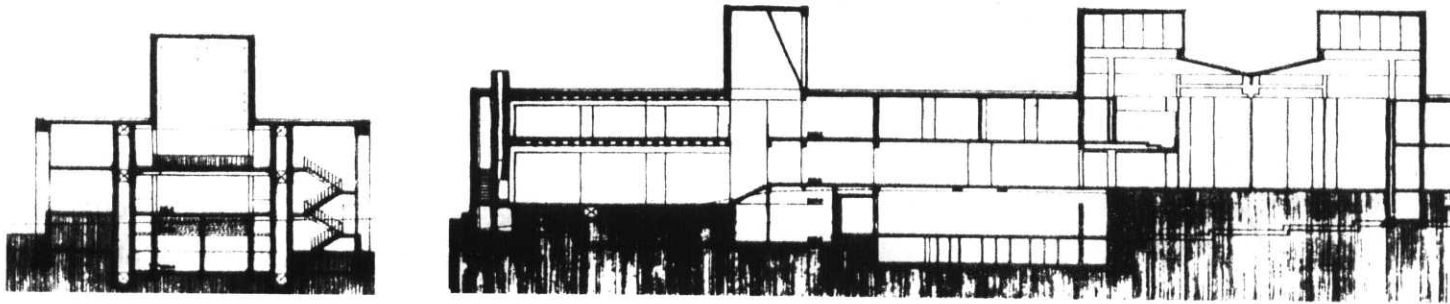

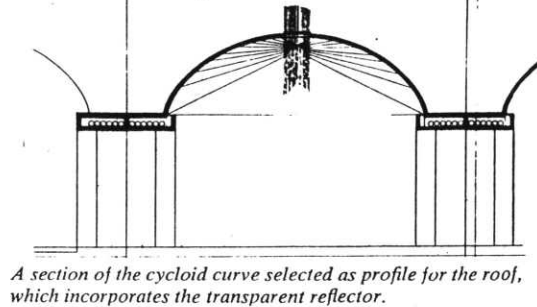
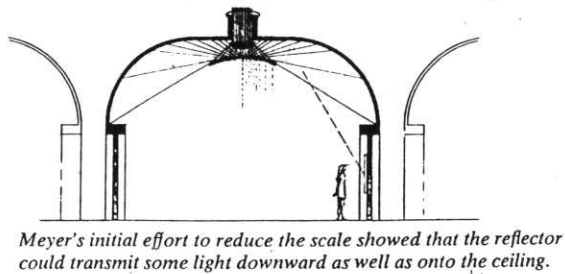
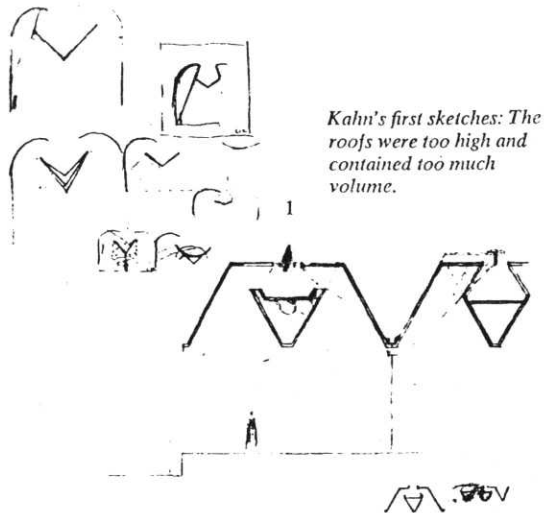

Unfortunately, artificial lighting always has to be used because it is not bright enough, and the gray and rough surface of a ceiling vault does not reflect a sufficient amount of light. The sophisticated skylight baffle system, although well designed from a theoretical point of view, supplies the Museum spaces with poor quality of diffused light. Most likely the baffles were not placed in the best way or a skylight well was not painted white.⁷

It seems to me that the concrete's gray surface of any building's structure is not a good solution to reflect daylight from, especially inside museum spaces.

The most noticeable benefits of daylighting in the Kimbell Art Museum spaces are gained from the narrow gaps of open, glazed surfaces at the end of each gallery's ceiling. Through these narrow strip windows daylight is provided and evenly diffused inside the galleries by the ceiling vaults, (2-29).

Before the project of Fort Worth's Kimbell Art Museum was even started, Richard F. Brown, Director of the

7. information from: Lam, William M.C., "Sunlighting as a Formgiver for Architecture," New York, McGraw-Hill, 1990.

Museum wrote to Louis I.Kahn in his pre-architectural program:

"Natural light should play a virtual part in illumination. ... The visitor must be able to relate to nature momentarily ... to actually see at least a small slice of foliage, sky, sun, water. And the effects of changes in weather, position of the sun, season, must penetrate the building and participate in illuminating both art and observer. ... We are after a psychological effect through which the museum visitor feels that both he and the art he came to see are still part of the real, rotating, changeable world."



2-28

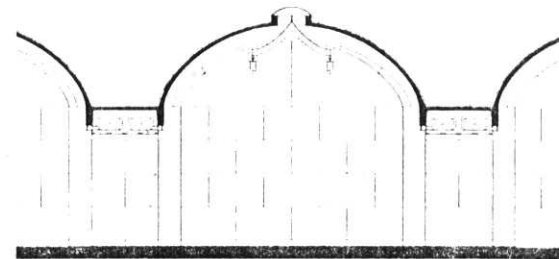

Reference:

1. Baker, Geoffrey H., *"Le Corbusier: An Analysis of Form,"* London, Van Nostrand Reinhold Co., 1984.
2. Fleig, Karl, *"Alvar Aalto 1922-1962,"* New York, Wittenborn, 1963.
3. Mayers, Marshalls, *"Masters of Light: Louis I.Kahn,"* AIA Journal, Vol. 68, No.11, September 1979.
4. Plummer, Henry, *"Poetics of Light: A+U Architecture and Urbanism "* Extra Edition, December 1987.
5. Ronner, Heinz, *"Louis I.Kahn: Complete Works,"* Boulder, Co., Westview Press, 1977.

PART THREE: Design

SITE DESCRIPTION:

“For Light possesses tremendous psychological power since it is so deeply immerseed In the furthestmost recesses of our unconscIOUSness and is so Intimately fused with our space experience as to be almost Identical with It. For visible space is lighted space, and with light therefore, we can evoke space experience. For light is one element; material object another, and the relationship of one to another makes up our visual world.”

Nathan Lerner

The proposed site for the John Paul II Church is located in a dense South End urban area, at the intersection Tremont and Berkeley streets, (3-01). An existing parking lot with an underground garage of one level belongs to the building complex of The Boston Center For the Arts. The Center consists of the Community Music Center, the Cyclorama, the Architectural Gallery, a newly built Boston Ballet Building and the National Theater which is closest to the selected site. A brick wall, which is 75 feet high ends the urban tissue of this complex and is nearly perpendicular to Tremont Street. Against this wall, on the available surface of a parking lot, the church spaces are proposed.

Two residential areas surround the Church complex from southern and northern sides. The eastern side of the site is open towards The Franklin Institute, Berkeley street and part of Tremont street. As mentioned above, the Western side is attached to the existing National Theater, which along with the high eastern and the walls of the proposed Sanctuary, Auditorium, and Lobby create an internal courtyard, a collective space for three separate Church entries, (plan: 3-02).

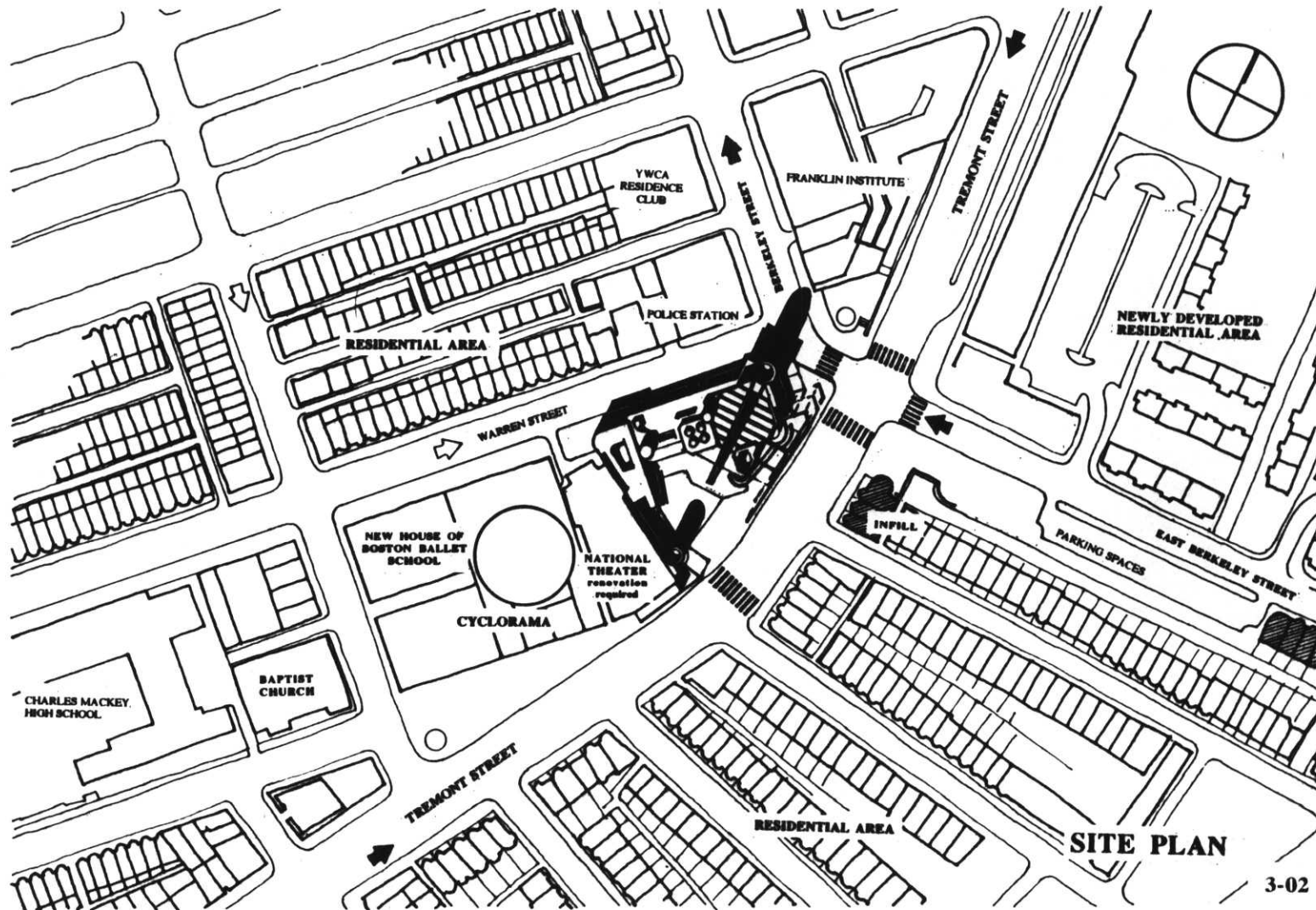

SITE PLAN

3-02

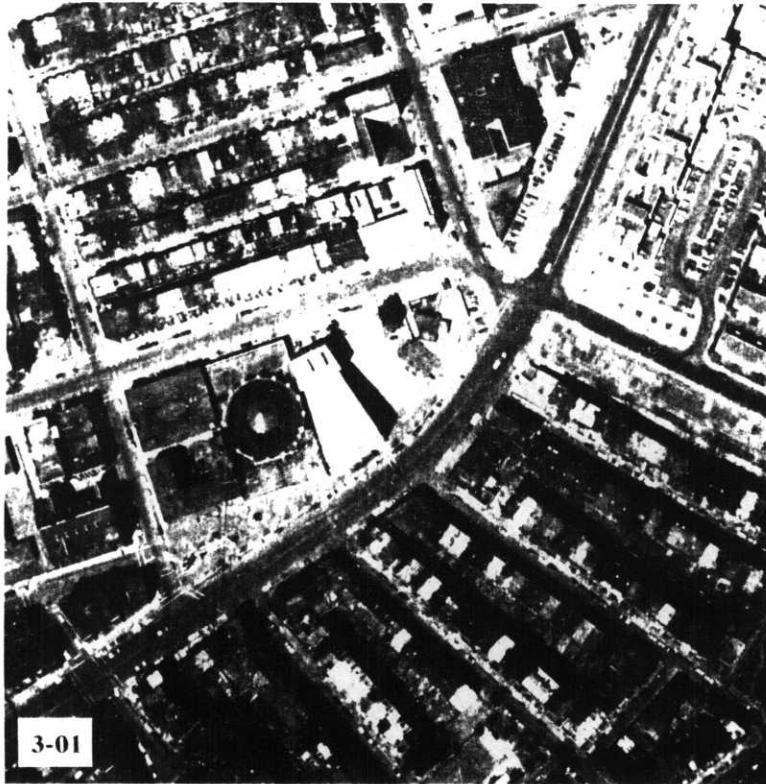

The monumental program for a church is suitable and for this site. Tremont and Berkeley streets' crossroad joint defines an entry gate to the oldest and most uniform, characteristic of New England urban development. Over eighty-five foot high, architectural elements would provide a necessary, man-made urban barrier between the old and new quarters of this Boston area, and would also intensify spatial experiences, (3-03).

The whole Cyclorama quarter is dedicated to public services. The rest of it should also be used for the same purpose. This site needs to be balanced, from an urban point of view. It should bring an optical attention to itself because it is located on the edge of two different urban developments and between three streets which create an important vehicular joint. Its location, north of the South End's major communication route, Tremont street, enables and even provokes the design of an inviting entry facing south.

BOSTON, SOUTH END

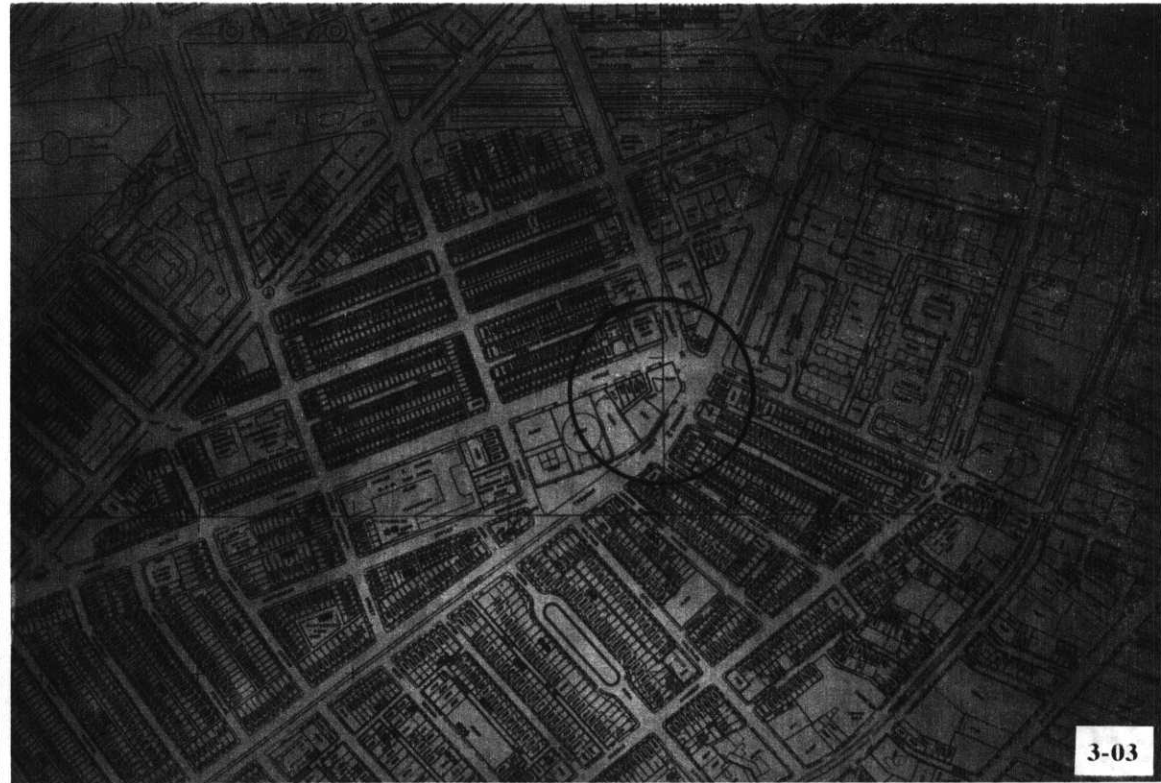
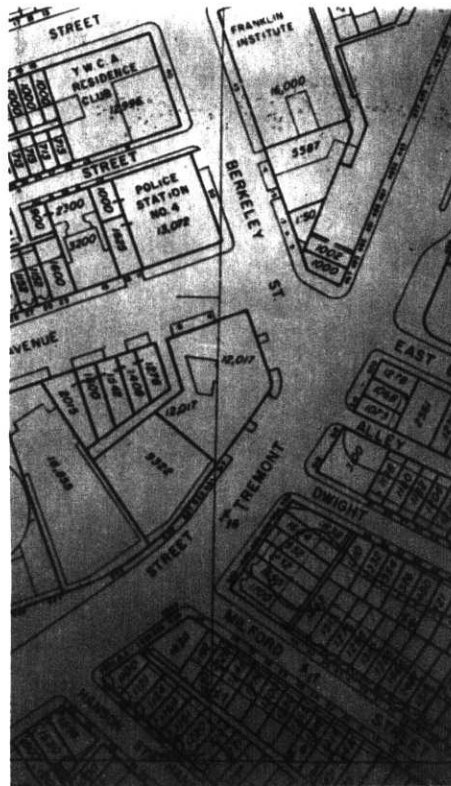

3-03

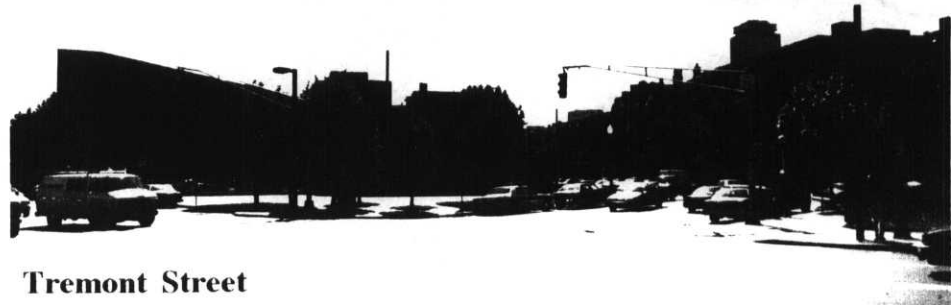

Tremont Street

SITE PHOTOGRAPHS:

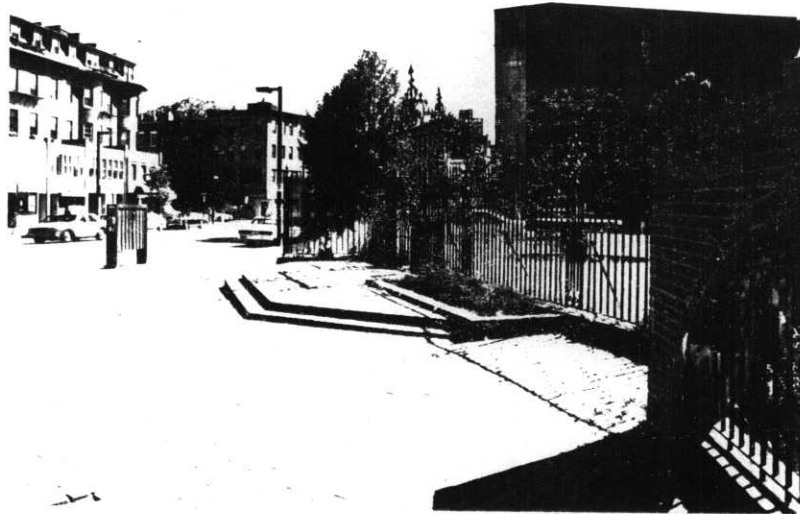

3-04. Tremont Street. Residential area on the left and the Eastern wall of National Theater on the right; where the courtyard is designed.



3-05. Towards the South, where the main entry to the courtyard and Chapel are designed.

3-06. Berkeley Street (North-East Sanctuary's facade). Police Station, J.H. buildings and Warren Avenue on the left.



3-07. Facing Warren Avenue. Only the Lobby, Waiting, Reading Rooms and Office spaces have visual contact with a street's Residential area.





3-07. Site's East overall view. From the left side : Residential area, National Theater, Berkeley and Warren Residential area; Police station.



3-08. Tremont Street with Cyclorama and National Theater on the left, (behind them, facing South, Pope's Chapel and Sanctuary's entry).

3-09. Overall site view from the North, towards designed Sanctuary, Sacristy and offices, which face Warren Ave. Light Tower on the left.



3-10. Down the Warren Ave. Designed Sanctuary with dominant 127 feet high light collecting Tower will compositionally close the street. The New Boston Ballet building will balance my massive design.

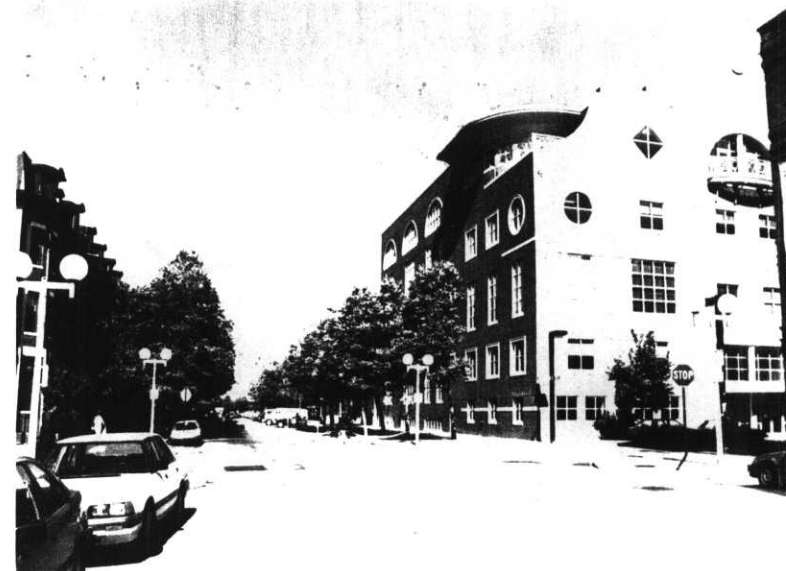



3-11. Typical for South End residential area (Appleton Street). Notice that entries are located on + 7' 00" above the street level.



3-12. Warren Avenue. All entries are located on +4' 06". Designed Church Lobby is on + 4' 00", Narthex on +6' 00" above the street level - to relate to the existing housing area, which surrounds my site.

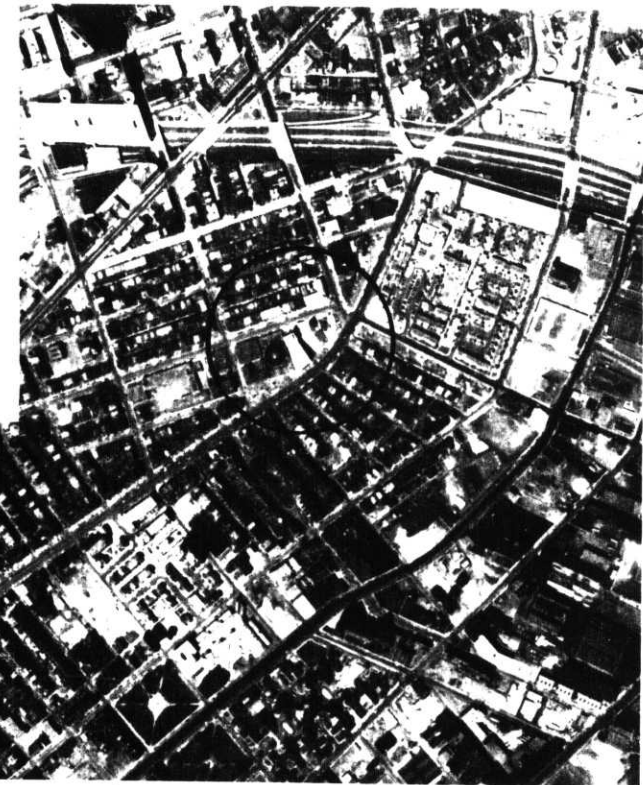

Boston and South End Communication Scheme.
Satellite photograph of the site was taken at midday.

**FORM AND DAYLIGHT AS SPACE
ORGANIZING DEVICE:**

“... variations in the quantity of light can be ignored, for though they can be measured with the help of instruments, we ourselves are aware of them. Bright sunlight may be 250,000 times more intense than moonlight and yet can see the same forms in the light of the moon as we can in broad daylight.”

R.E. Rasmussen

The main goal of this design is to achieve a variety of spaces which result less from consideration of light levels and brightness ratios although this important issue will also be discussed, than from careful, simple design and perception of where the light is coming from. It seems to me that an environment is the most comfortable and pleasant when illuminated from surfaces, which are themselves pleasant to look at, such as walls and ceilings, rather than from strange fixtures. This requires careful integration of structure, daylighting and designed spaces.

This Church complex includes six main spaces:

- 1. SANCTUARY with BAPTISTERY**
- 2. LIBRARY**
- 3. AUDITORIUM**
- 4. MEETING ROOM with CAFE**
- 5. LOBBY**
- 6. NARTHEX with CRYING ROOM**

It was an intentional move to create a level differences among the three groups of different spaces, (3-11).

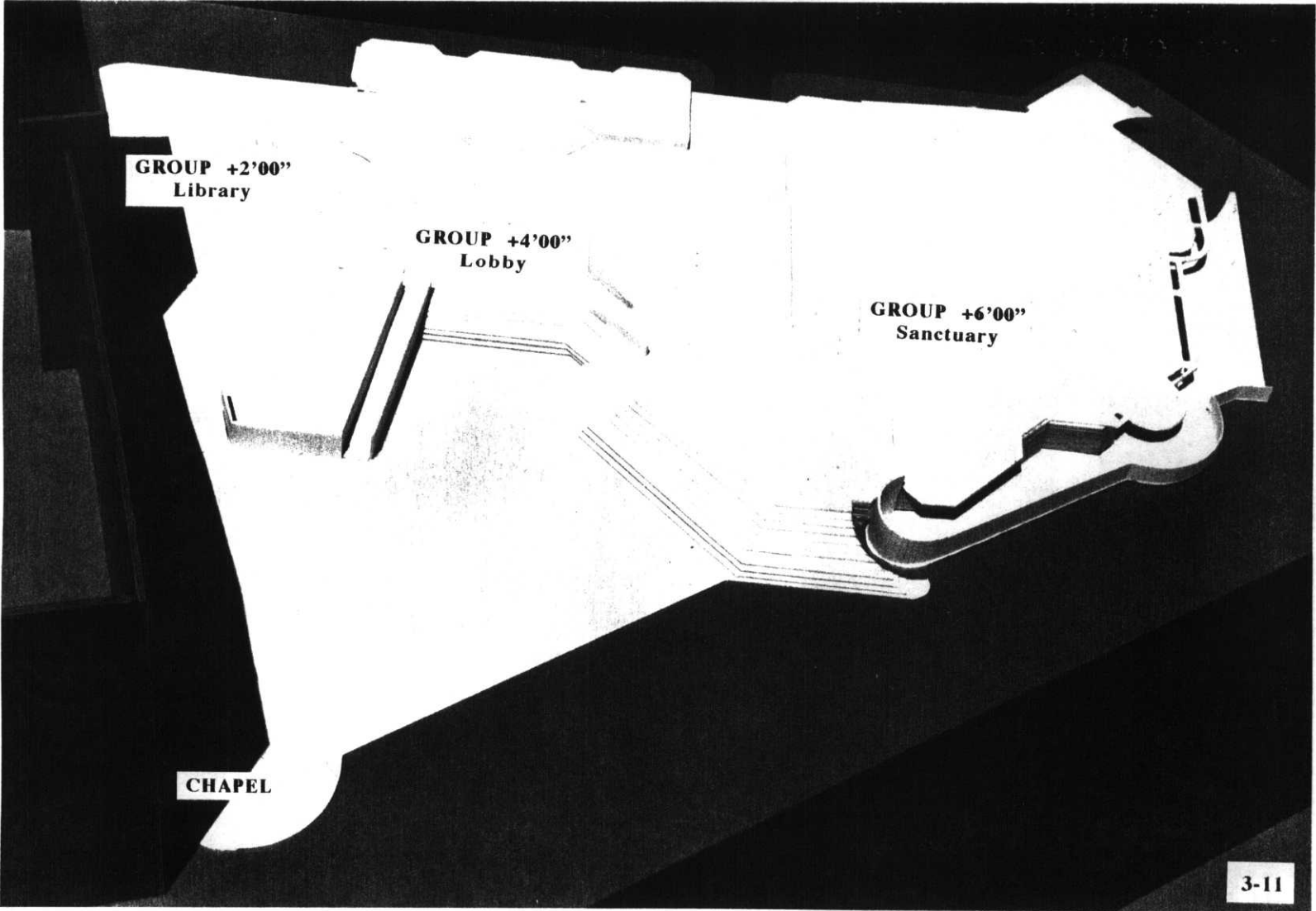

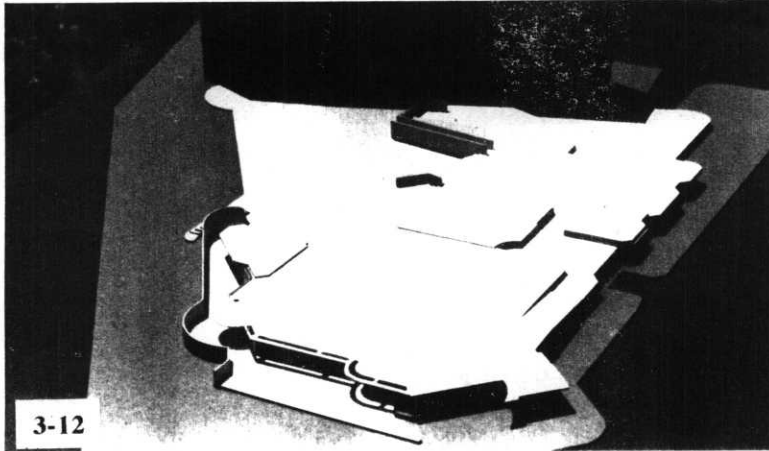

3-12

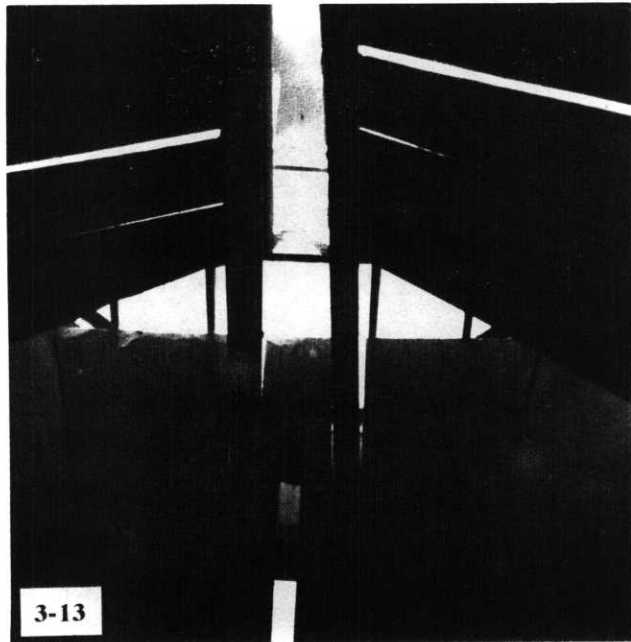

3-13

First Group: + 6' 00" above street level
 - Sanctuary, Narthex, Crying Room (the Altar +8' 00")

Second Group: + 4' 00" above street level
 - Lobby, Auditorium (Meeting Room with Cafe +5' 00")

Third Group: + 2' 00" above street level
 - Library, Reading Room (second floor +24' 00")

The First Group consists of a peaceful space dedicated to worship - the Sanctuary with the Narthex and the Baptistry, (3-12).

This group of spaces closest to God should not possess any visible contact with the ground surface. Here, use of form and daylight is particularly unique in the Baptistry and Main Altar for example. The structure of the ceiling provides a linking strip of light between the Narthex and the Altar. This reinforces the physical metaphor of Life and Death which connect the outside world to God, who is represented here as a priest and a hollowed out cross of natural light. Entry to this Sanctuary in the Narthex precisely divides both worlds in a set pattern of light - darkness - light. The wider end of the ceiling skylight,

which is a result of shifting structure, leads us toward the altar and up to God, (3-13).

The Second Group consists of the Auditorium, Meeting Room with Cafe, Lobby, and connecting passages.

The Auditorium, which can be used as a Sanctuary extension during religious events, is located between the Library and the Sanctuary and attached to the Lobby that receives incoming people. Here, four large conical wells provide the Auditorium with diffused and evenly distributed light. Illuminance is reduced by structural beams that come through each well, (3-14). These spaces, except for the Auditorium, should be separated from the Sanctuary and the Library. A variety of different direct and indirect light can be found here. Large surfaces of external panel-like windows reflect the adjacent residential buildings. The result of the structure meeting the external wall along the whole northern facade allowed me to shape the Baptistry, the Main Altar and the Crying Room more freely. The idea of allowing structure to separate from the building facade fulfills the

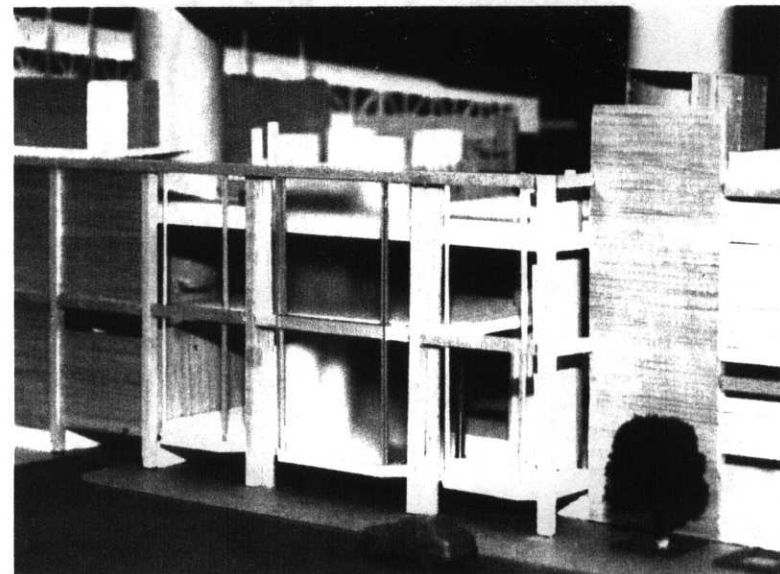
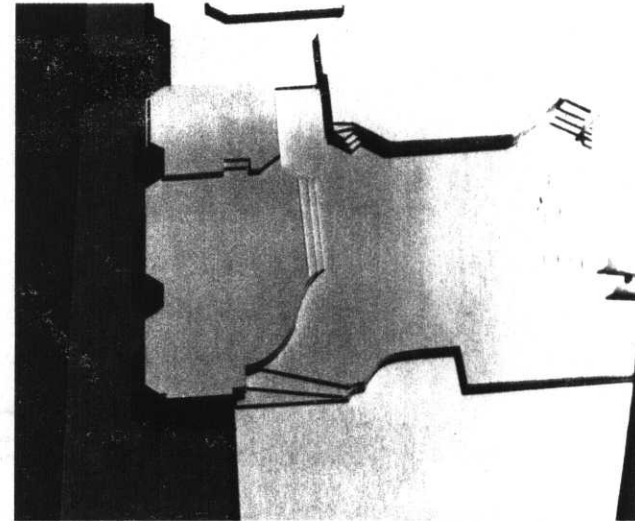

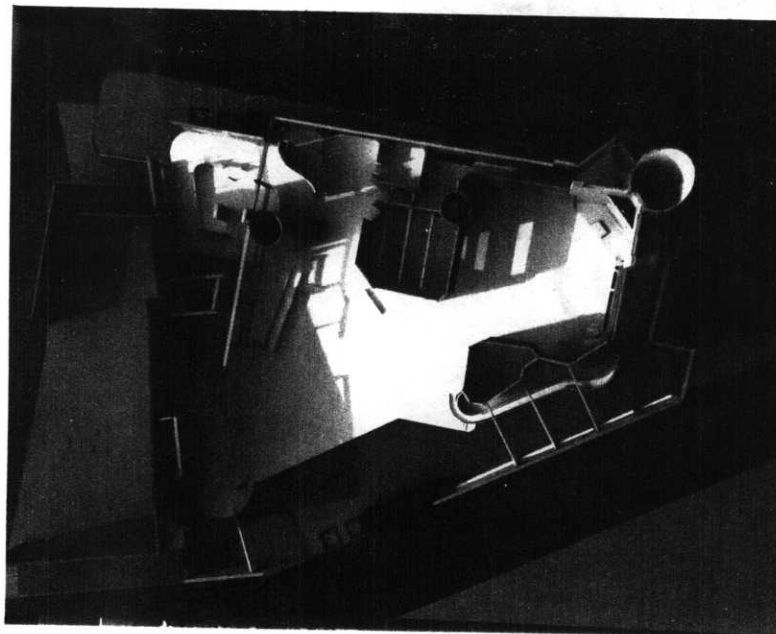
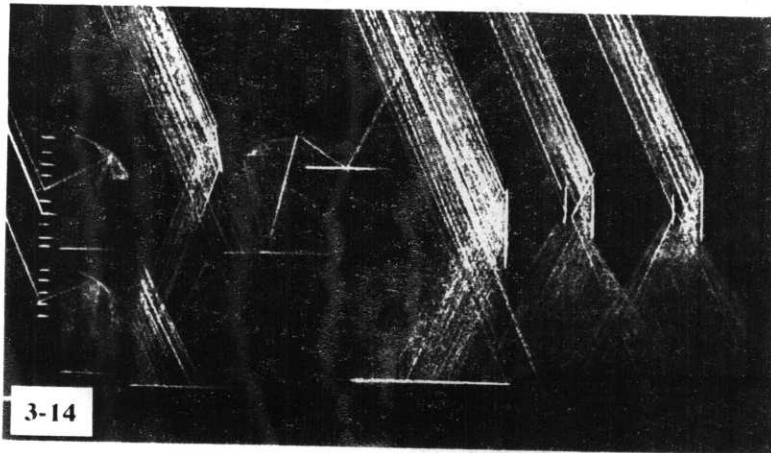

need of creating a straight directional edge which is parallel to Tremont Street. This physical edge gives direction towards the entry and wraps the whole dense block of urban tissue from East and South, (3-16).

Except for the Lobby and Auditorium, all spaces receive northern indirect light through large floor to ceiling windows. The Lobby with its clerestory on the second floor provides additional diffused but strong ceiling light, supplied by an eight by fourteen feet wide skylight. It is possible to see all the way through the Lobby and the Meeting Room. The structure is supported by columns, and delivers large amounts of light, giving an undisputed statement about the entrance and Lobby location. This is enhanced by the glazed, large Lobby entry that faces south-east, (3-15).

The Auditorium is provided with diffused ceiling light by four conical skylights, as in the Viipuri Library, Pension Institute Building, Rautatalo Building, Wolsburg Cultural Center. This evenly distributed diffused light which is the best for long meetings and conferences, is the major element modulating the space. This is the only space from

the Second Group that carries such evenly diffused light. There is a visual connection between this glazed space and a Hallway for orientation and daylighting purposes. The wider part of this Hallway, that offers more space before entering the Sanctuary, staircase or Sacristy Hallway, collects additional diffused light from a partly opened wall towards Warren Avenue. The shifting form and structure play a major role in obtaining direct or indirect light on the second floor's Hallway. Here, daylight is reflected from a bright roof surface, (3-16).

The Third Group consists of the Library Stack Room on the first floor and the Reading Room on the second floor.

In the style similar to Aalto's Seinajoki Town Hall and the meeting room of the Wolsburg Cultural Center, daylight enters clerestories high in the wall plane to the West side of a building and then is diffused or directed by a curved ceiling plane. Automatically adjustable venetian blinds in the wall plane protect the spaces from direct sunlight. A large skylight provides additional light in the central part of the Reading Room. The Library's entry acts as a

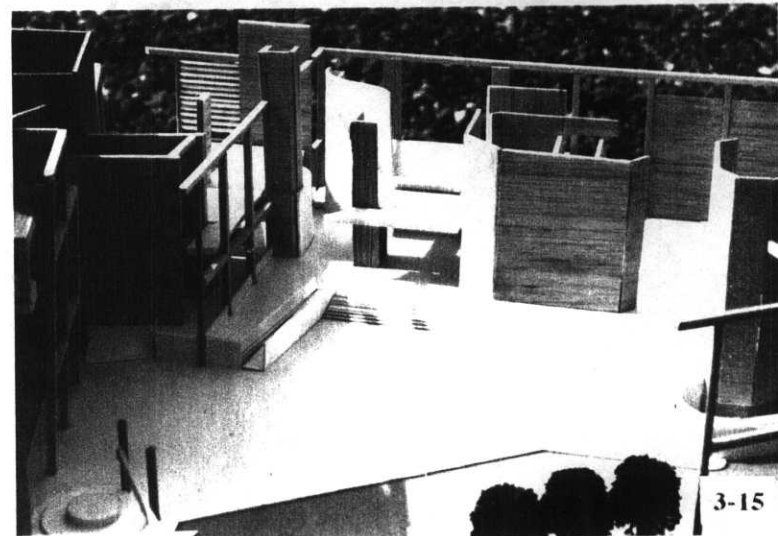
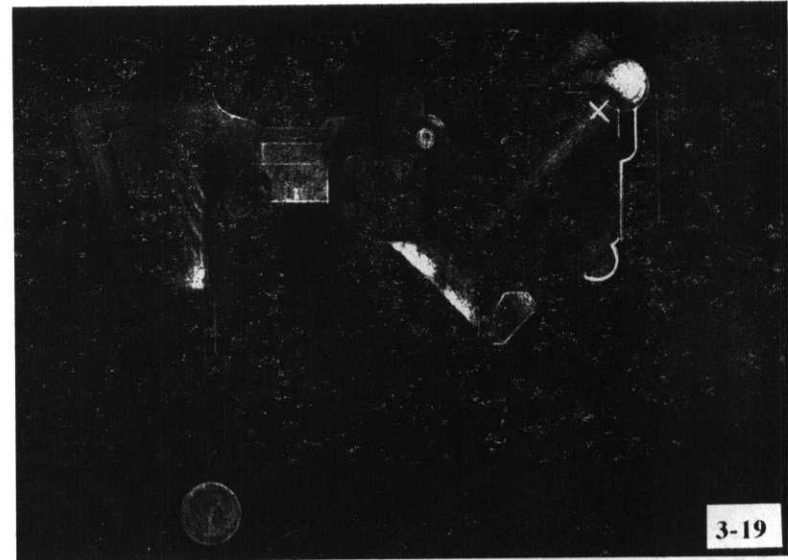

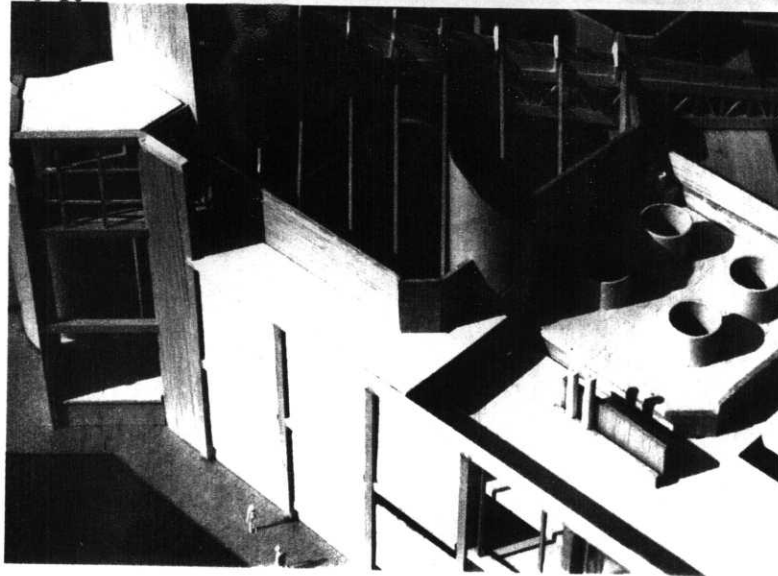
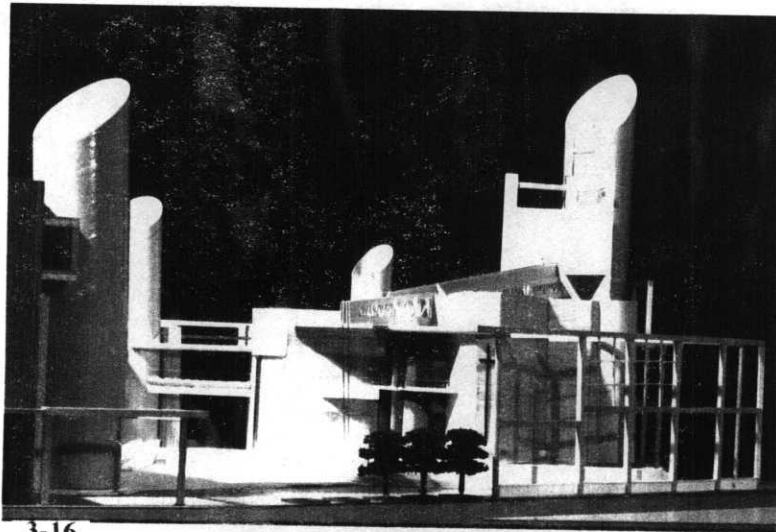

transition from a very bright Lobby, full of direct and diffused southern light, to a variation of diffused and soft light, where more intense manipulation of the ceiling is important for both spatial and lighting purposes. This space's light quality is based on the best architectural solutions found in Aalto's works - his libraries, and clearly defines the direction of light, (3-14, 3-19).

Along with the semi-translucent wall, which protects book stacks from strong and direct sunlight) and divides the Library from an outside Courtyard, an additional exit is designed. The first floor's surface is strongly painted by the direct light where the lower part of the wall is fully transparent. This precisely defines an exit from the Library. The exit with a glazed surface provides some extra light which is necessary in the area late afternoon when sunlight enters the western side of the building. What is most important, from the directional point of view, is the balance of the Lobby entry's illumination level with the same amount of directional light. Notice that the Reading Room's entry is defined by western daylight reflected from a curved parapet wall and also by a clerestory, (3-18). Here, just like in Le Corbusier's Sainte

Marie de la Tourette, the public area is indicated by a screen of “lamellas” that bring direct light into the space and whose rhythms of form and shadows break this cool and simply designed part of the building, (3-19).

It is worth mentioning a few more words about the perception of light in the Sanctuary. Entering the Narthex, straight in front the main Altar with its “hollowed cross”, two walls colorfully washed by daylight appear. The Altar is designed on the Sanctuary's north-south axis. It is linked with the Narthex by a narrow strip of light, which follows the north-south direction all the way through the ceiling's structural gap, (3-20). Both sides of the Altar are colorfully painted by strong and direct sunlight between 8 am and 4 pm, and reflections are planed. Constantly in motion, passing through the colored oils, these reflections spatially define the most important place of this area. Here, the simple form of two walls closed by a hollowed cross in the narrow background of the Altar, is a structural frame for a unique solution: motion, color and light. This theatrical setting, to my knowledge and personal feeling, is well suited to the purpose of this heavenly space, where light should play a significant and

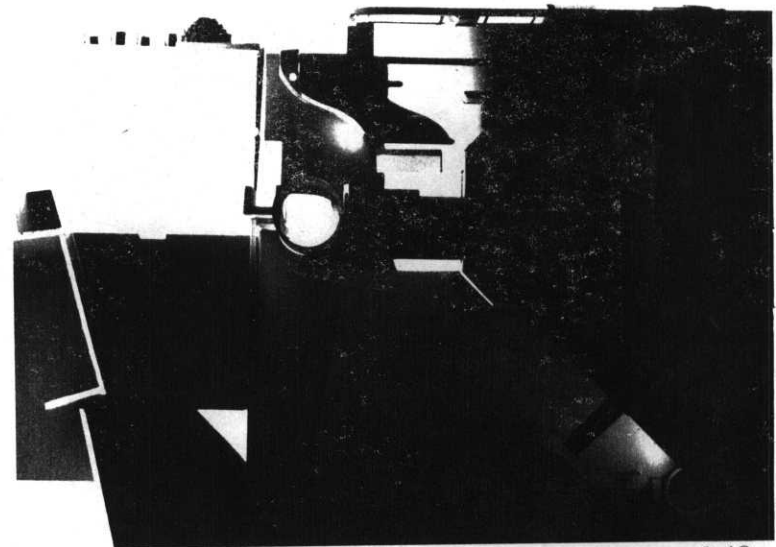

3-18

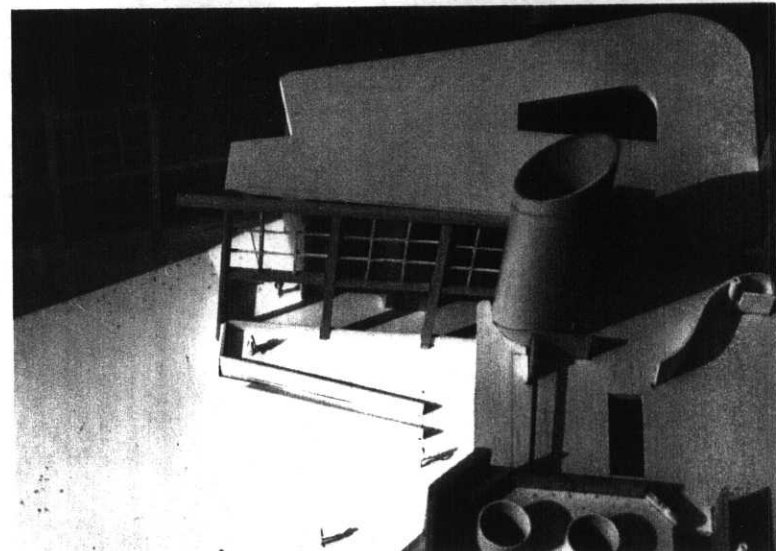

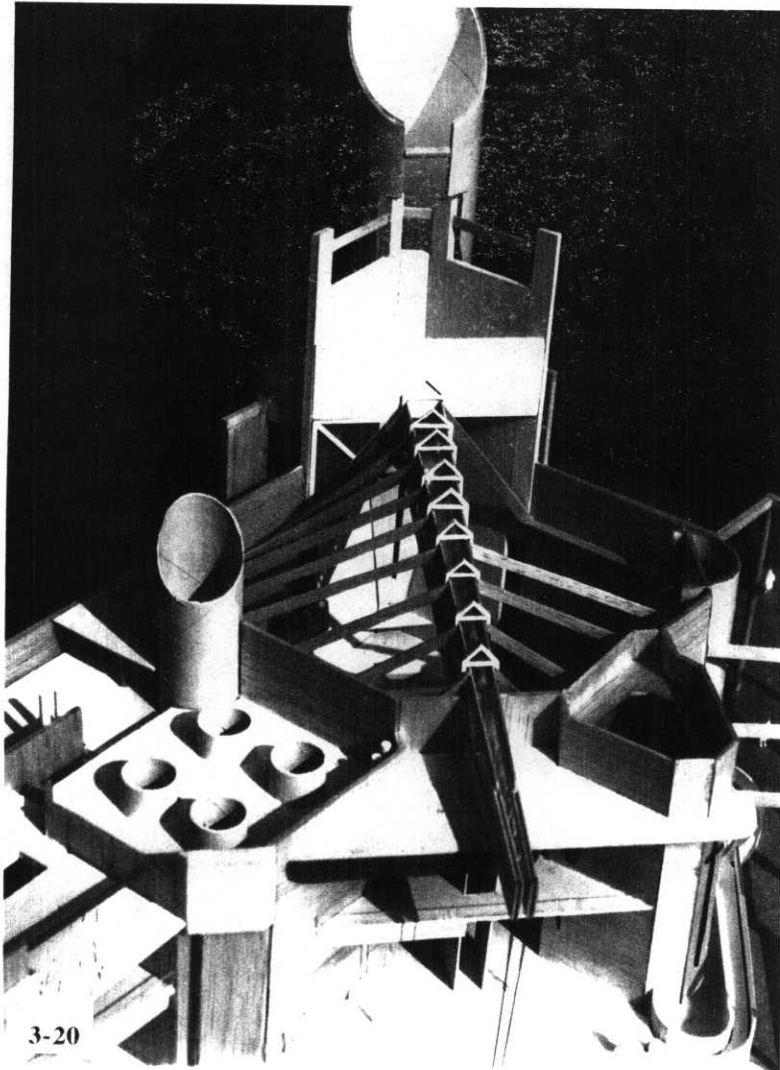

special role. On the left side of the Narthex, a secondary entry to the Sanctuary is defined by diffused light filtering along curved walls of an internal staircase. On the right side, the Baptistry is located. Here, dual openings along the curved floor and ceiling edges provide a very mysterious, but pure lighting effect - so appropriate for this unique and special space. Curved and located in the right corner of this modest, almost rectangular church space, the Baptistry located. It is linked with the Main Altar and a priest's preparation room with the Sacristy by the floor provided light, similar to MIT Chapel, which is reflected from the pool of water, (3-21).

The flexibility of a changing linear form of the Sanctuary walls for lighting purposes, is present in the Crying Room, placed close to the main entry. This enclosed space, adjoining the church from the south side, has one large single skylight that provides the space with direct sunlight. This offers a warm and bright glow, which is in sharp contrast with the cool and diffused by the pool of water the Baptistry's light. The Crying Room's form seems rather complicated. But as a result of some important design moves, the room directs visitors toward

the entry, allowing proper distribution of light, and defining the Sanctuary's entry, (3-22).

Behind the Altar, a barrel-shaped tower about 125 feet high collects the best southern light and diffuses it into the Priest's Preparation Room, the Sacristy and a staircase. The staircase connects three floor levels, garage included. The same bright white light is reflected from behind through the hollowed cross. Surrounding the cross are two concrete, white washed walls that reflect rainbow like colors from an overhead transparent container full of red, blue and yellow oil. Large amount of diffused light in this area have directional quality as well.

The linear skylight which connects the Narthex and the Altar is mainly glazed by semi-translucent glass dimmed from fifty to ten percent from the Narthex's side. Such gradual light distribution is necessary to block direct and strong sunlight from penetrating the Sanctuary's space. The part of the Sanctuary skylight closest to the Altar is almost twice as wide as the opposite side. This intentional move follows the main idea of visually defining the Altar space. A ten foot wide skylight, between

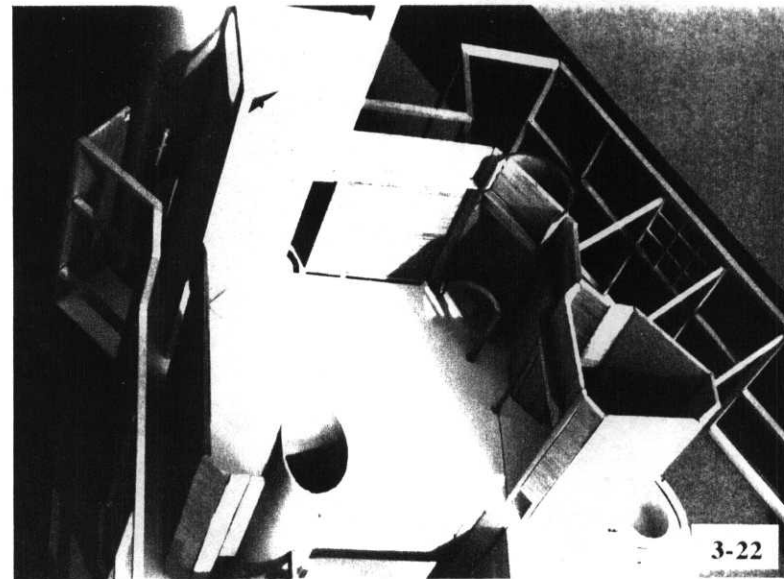
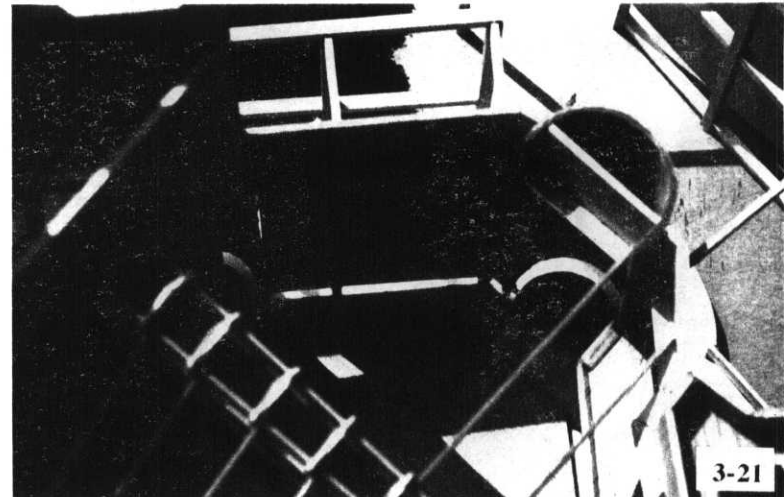

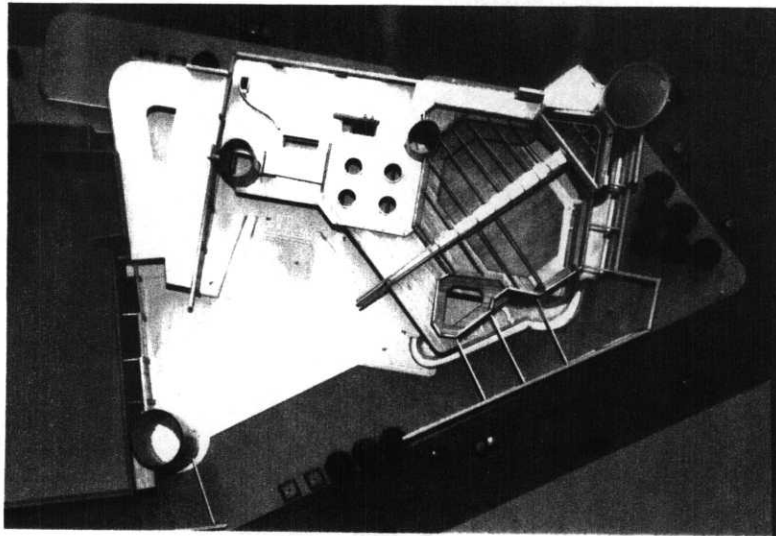

two large glue-lam trusses, is also used to hold a set of two computer controlled, light reflecting mirrors, which direct southern sunlight towards the Tabernacle, around midday only, (3-23).

The purpose of directing a strong beam of daylight toward the place where a Tabernacle is located is to build up and increase the meaning of mass. This would provide maximum effect during the important parts of Catholic events, such as Elevation and Holy Communion.

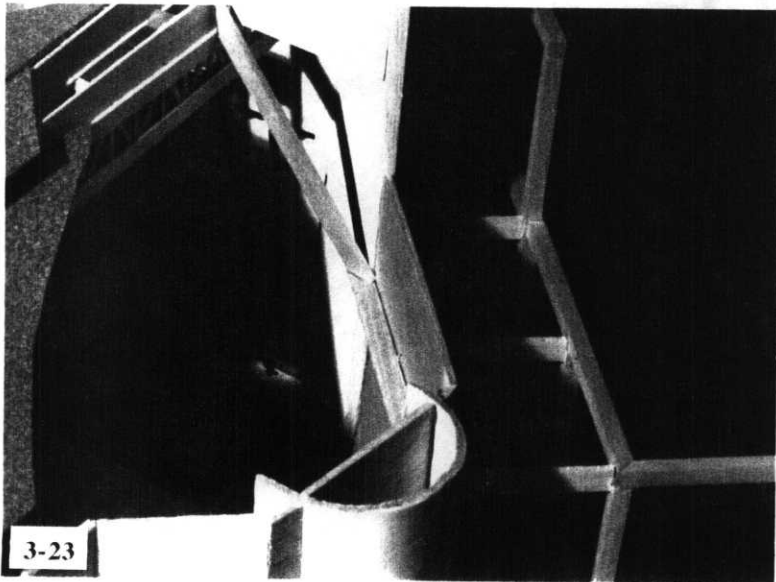

APPLICATION OF DAYLIGHTING:

- DAYLIGHTING DIAGRAMS
- DAYLIGHTING TECHNIQUES
- MODEL PHOTOGRAPHS

"From the vast central dome, space expands into half-domes and conchs, flows between straight and curved arcades, and filters through stacks of windows. From every position within the Church, views open into spaces seen in whole or in part, along axes or on diagonal, seeming to expand or to contract. Color and decoration enrich the space, deny mass, disguise structural elements, and visually dissolve solid areas. Light from a multiplicity of sources amplifies these effects, entering the central space directly from clerestory and dome windows, or indirectly through aisles and galleries. Different intensities of light refract on the multiple curved and angled surfaces, denying the presence of mass and material substance."

Justinian about Solomon's Temple

This paragraph's intention is to present some additional examples of daylighting methods and techniques used throughout the design of the Church complex .

There are three groups of illustrations included in this part of the thesis:

1. daylighting diagrams
2. daylighting techniques' schemes
3. model photographs

All findings applied in my design of "form and daylighting" are methods based on research, which were introduced in summarized forms in Parts One and Two of this thesis.

CHURCH COMPLEX I FLOOR FORM AND DAYLIGHT DIAGRAM

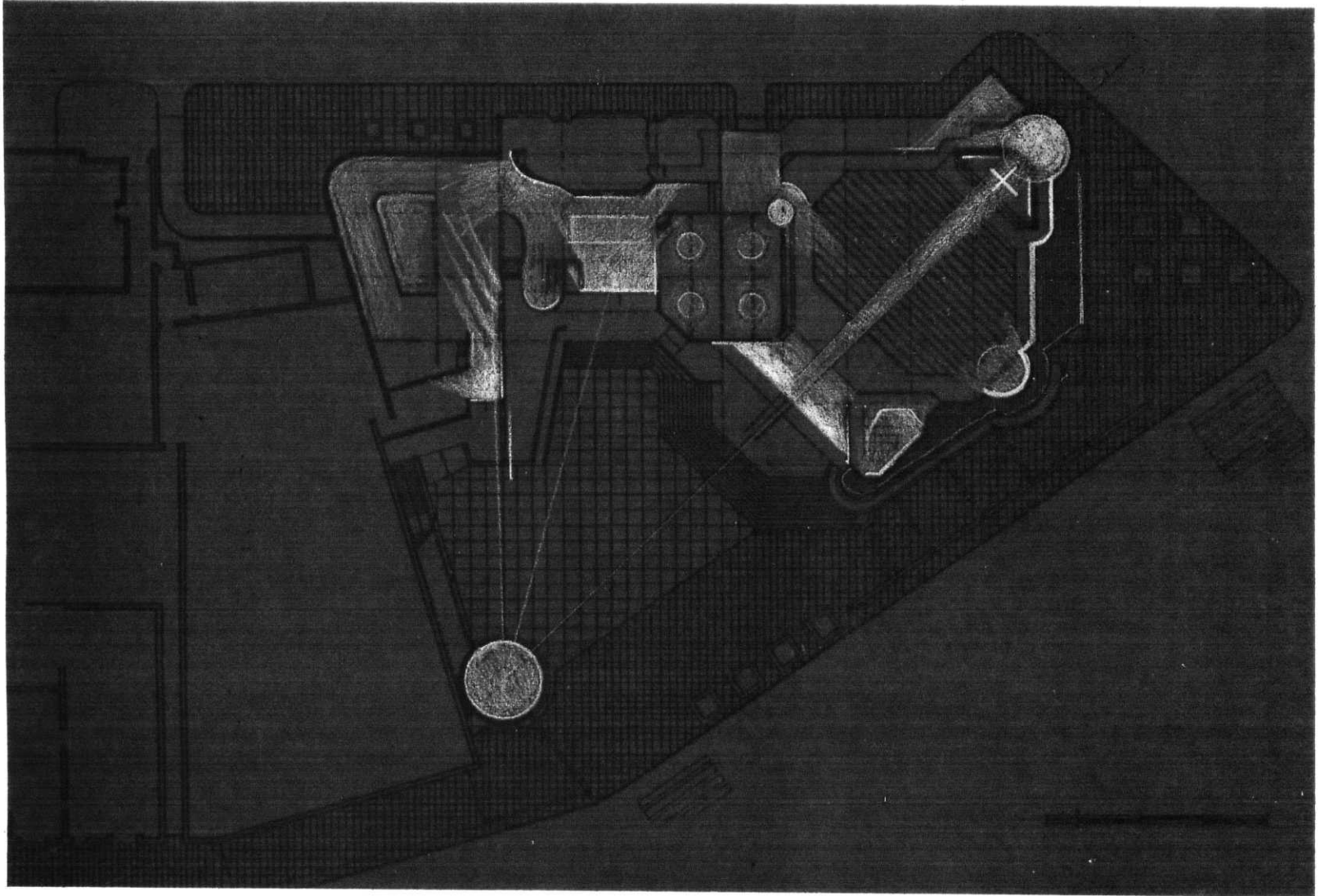

FIRST ILLUSTRATION:

**LIBRARY, LOBBY, READING ROOM
AND AUDITORIUM FORM AND
DAYLIGHT DIAGRAM**

SECOND ILLUSTRATION:

**SANCTUARY AND ALTAR FORM AND
DAYLIGHT DIAGRAM**

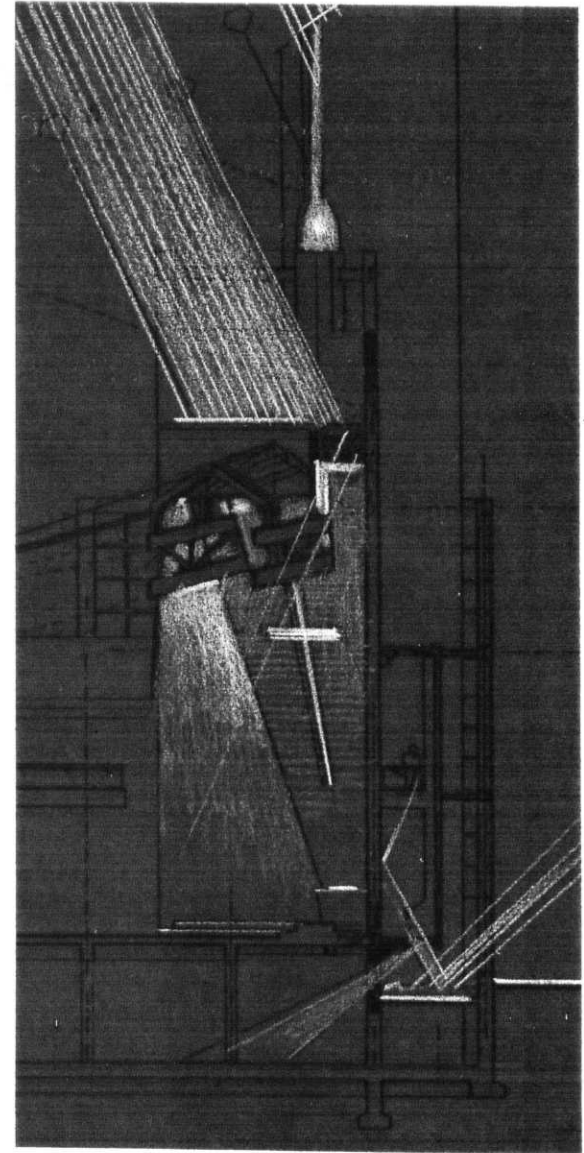
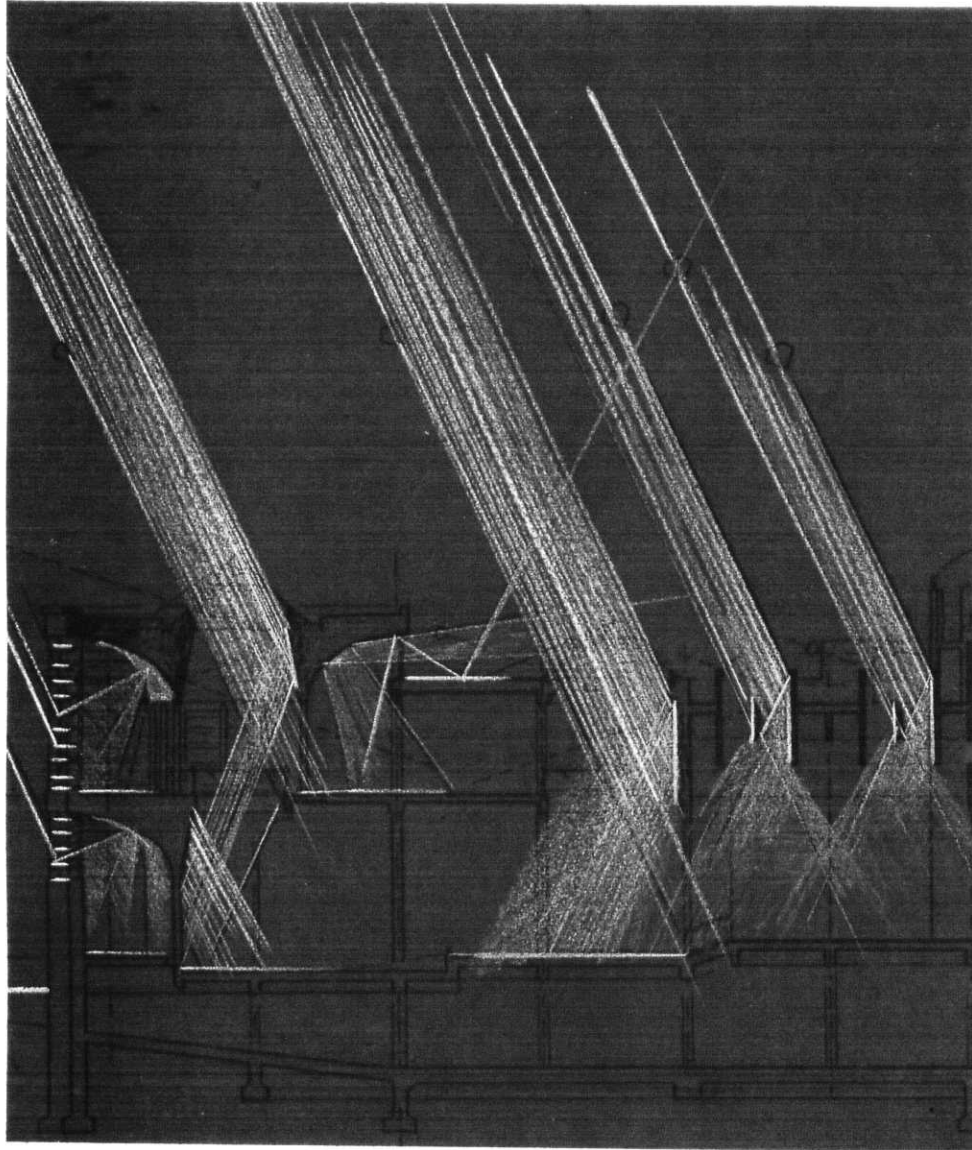

**JOHN PAUL II CHAPEL DAYLIGHTING
DIAGRAM**

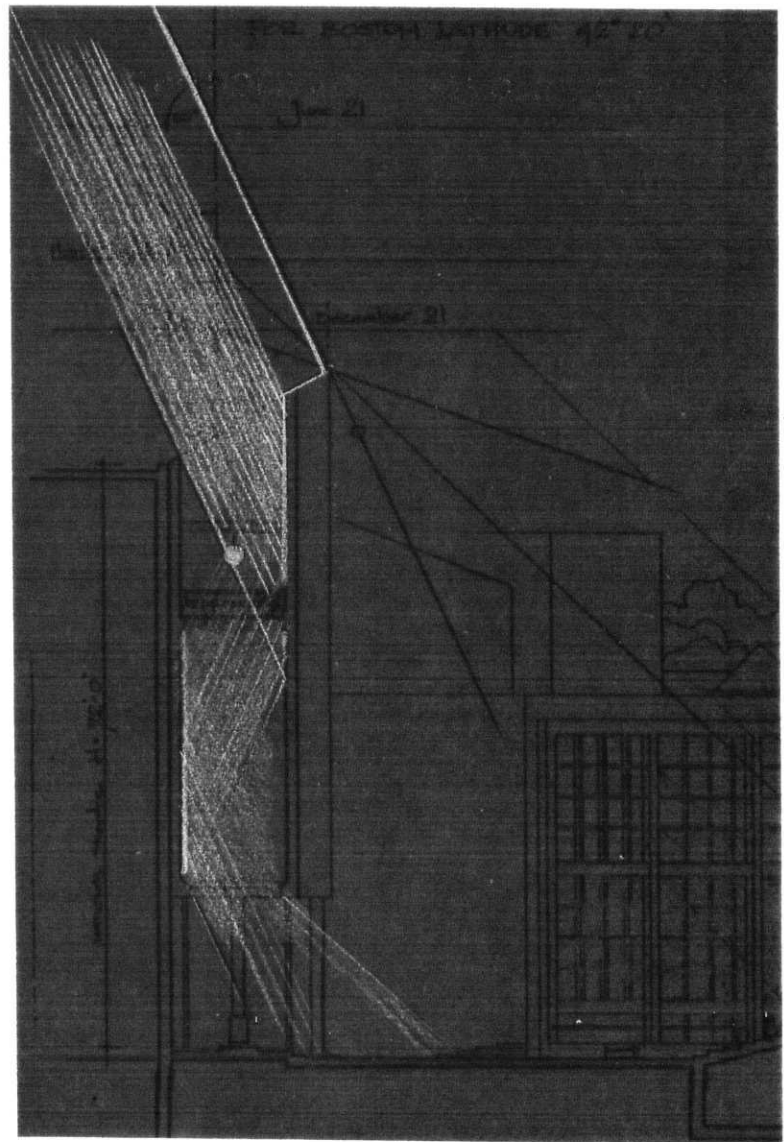
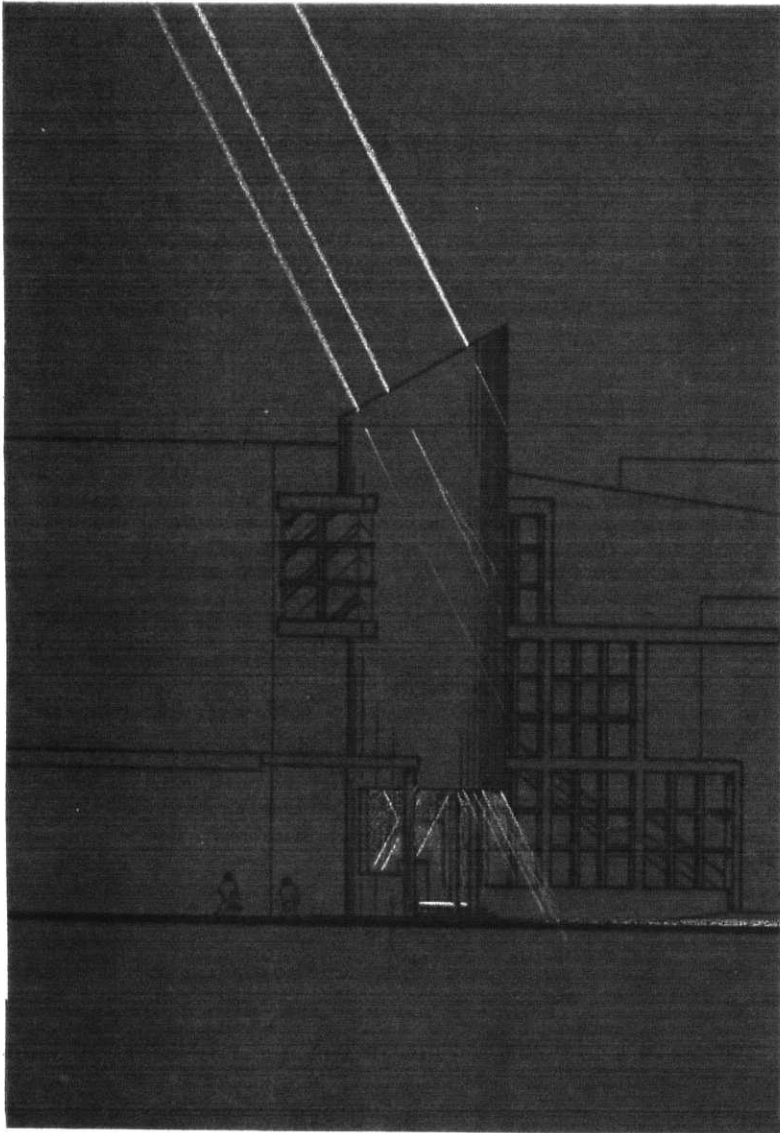

CRYING ROOM DAYLIGHTING DIAGRAM

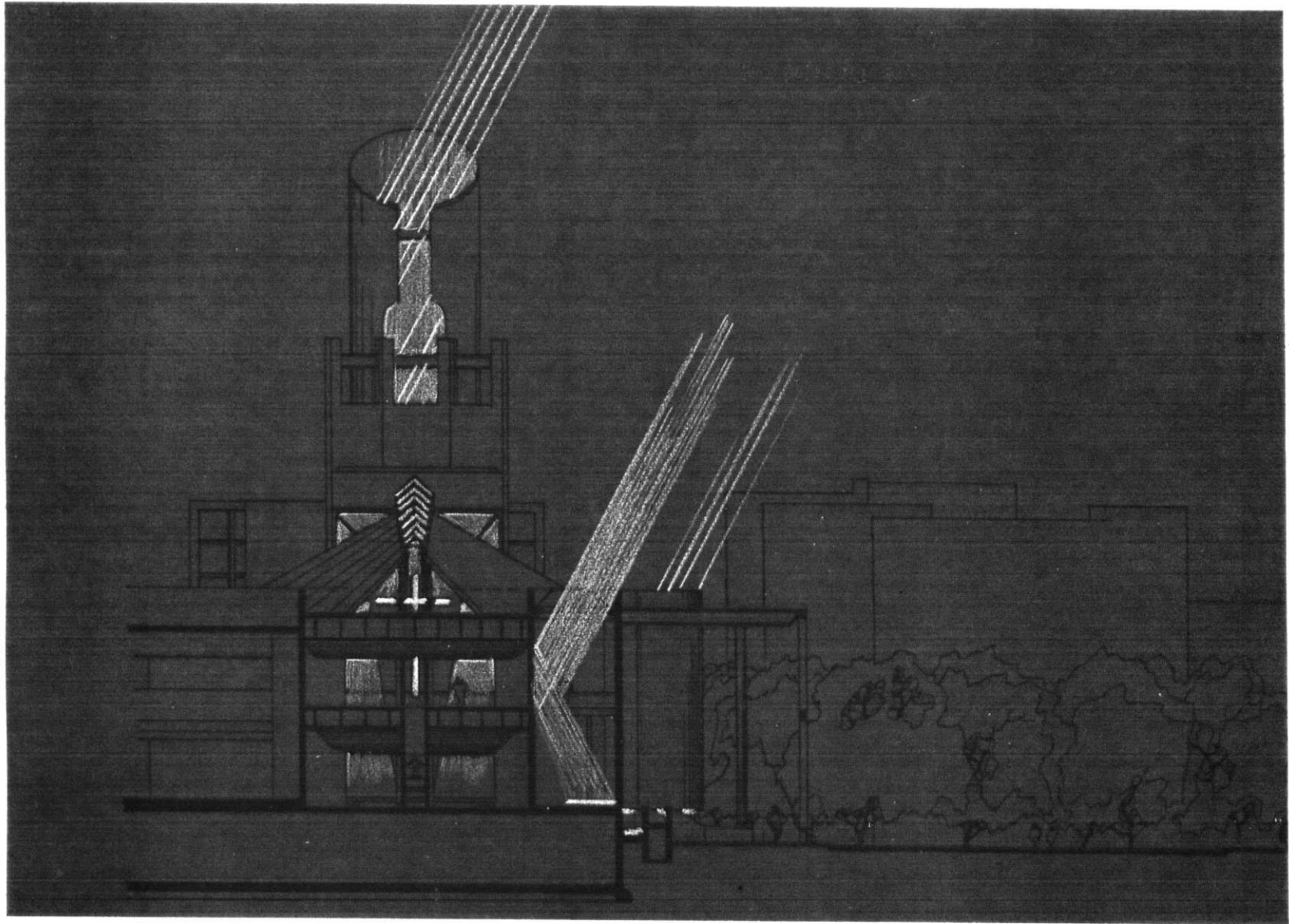

**NARTHEX AND SANCTUARY SPACES
ILLUMINATION AND LIGHT DISTRIBUTION
SCHEME**

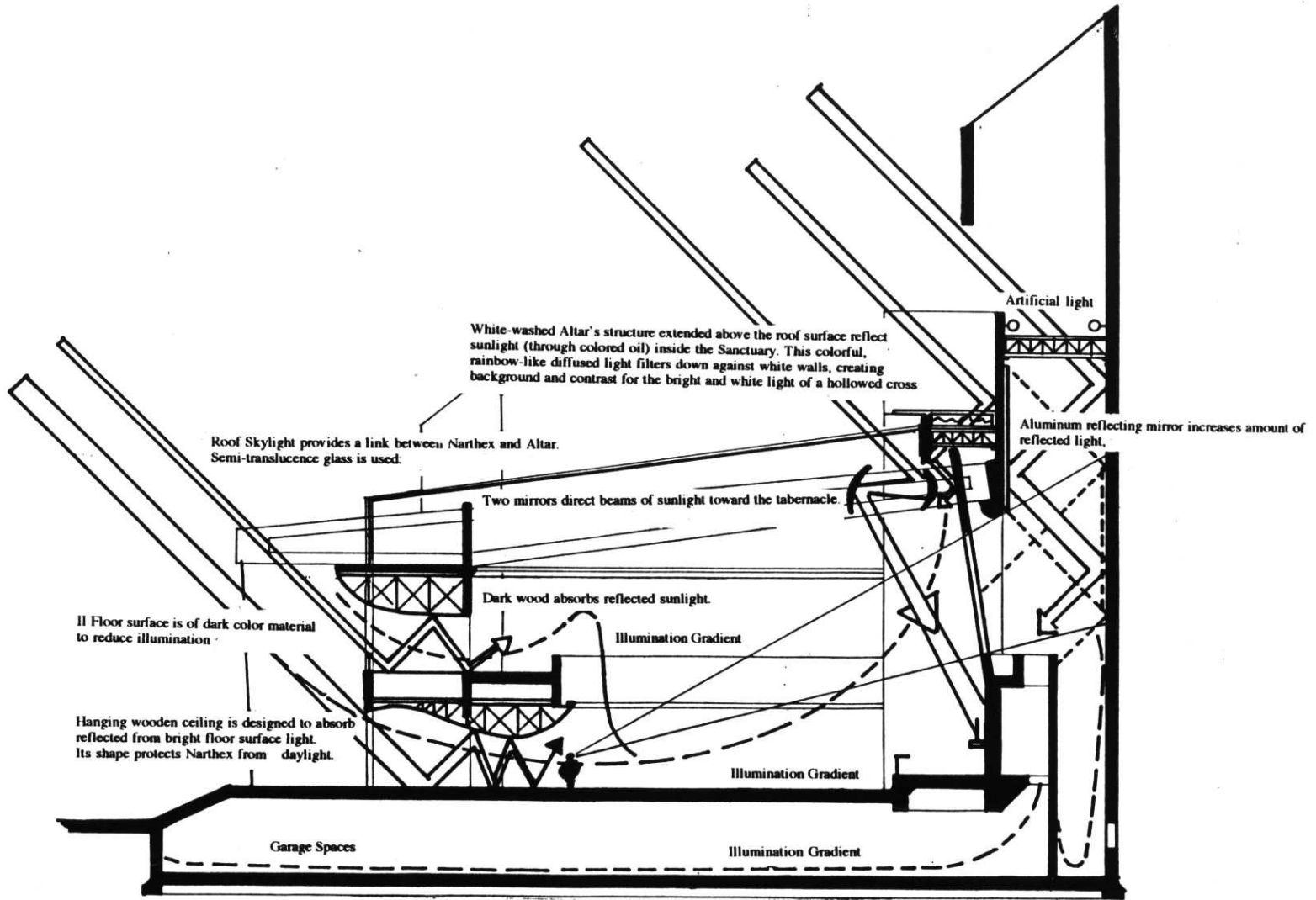

**OFFICE SPACES HALLWAY AND LIGHT
COLLECTING TOWER DAYLIGHT
DISTRIBUTION SCHEME**

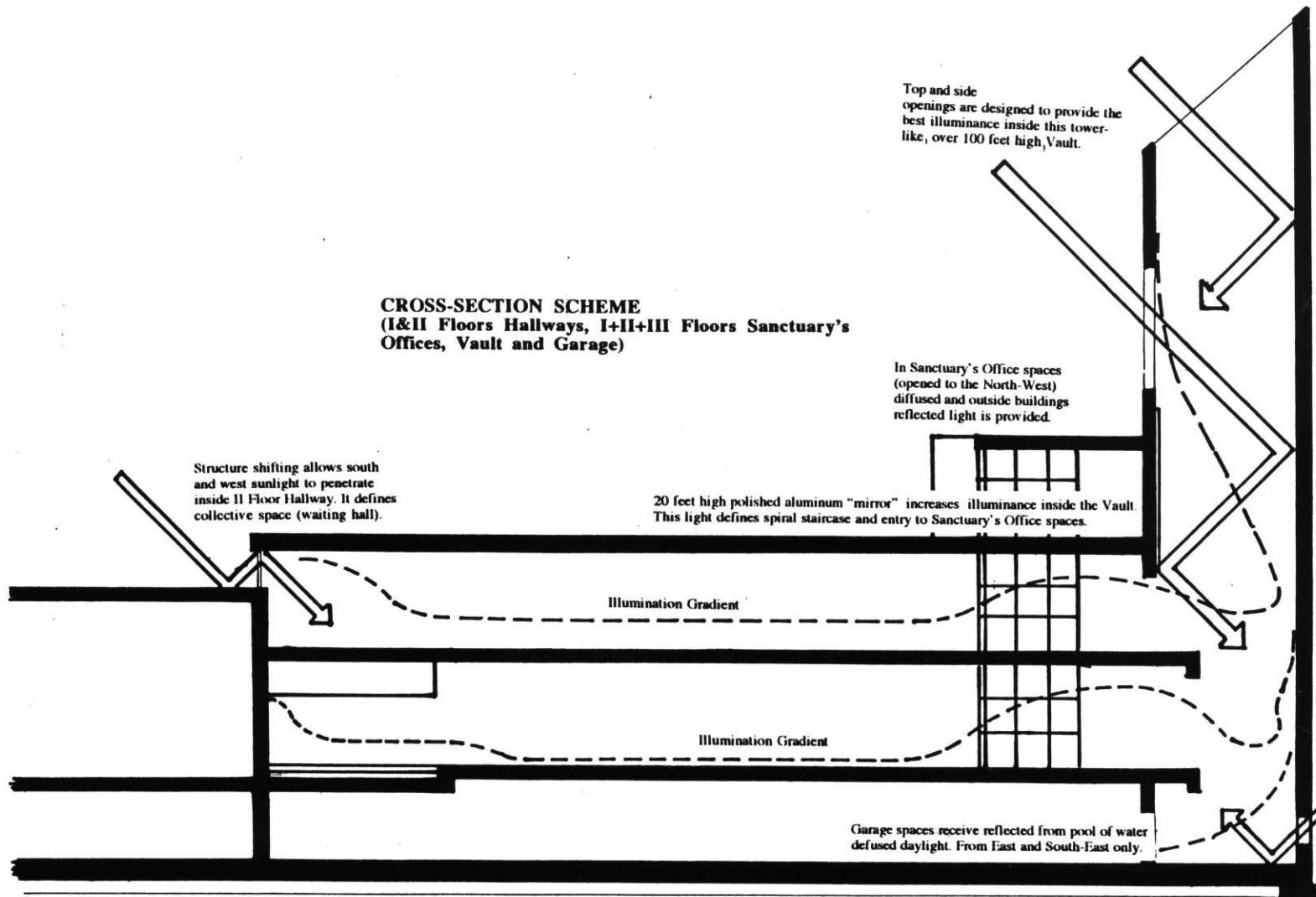

**AUDITORIUM AND LOBBY SPACES
ILLUMINATION SCHEME**

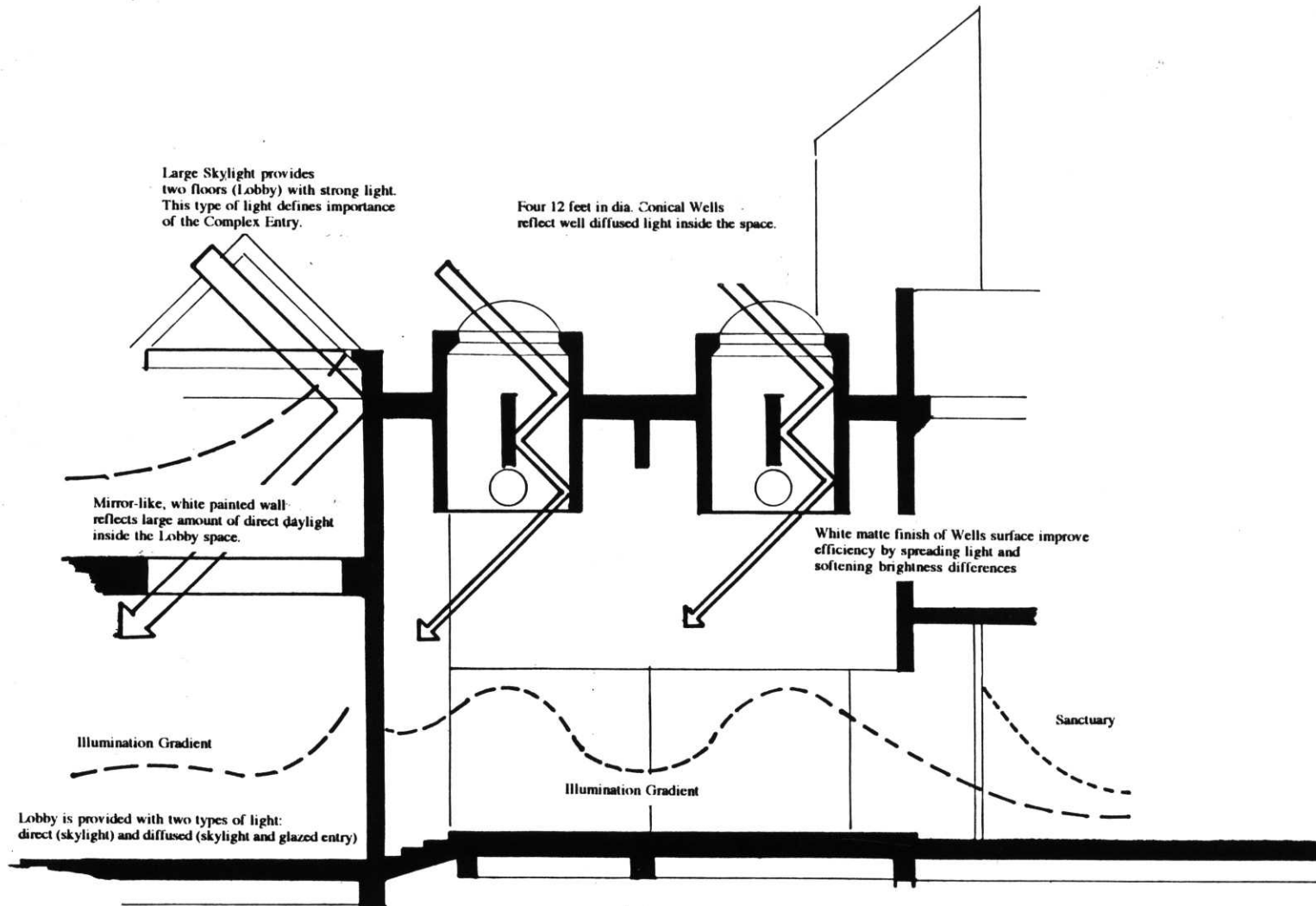

**FIRST ILLUSTRATION:
READING ROOM AND LIBRARY
SCHEME**

**SECOND ILLUSTRATION:
LOBBY AND MEETING ROOM
ILLUMINATION SCHEME**

**THIRD ILLUSTRATION:
SANCTUARY AND CRYING ROOM
DAYLIGHT ILLUMINATION
SCHEME**

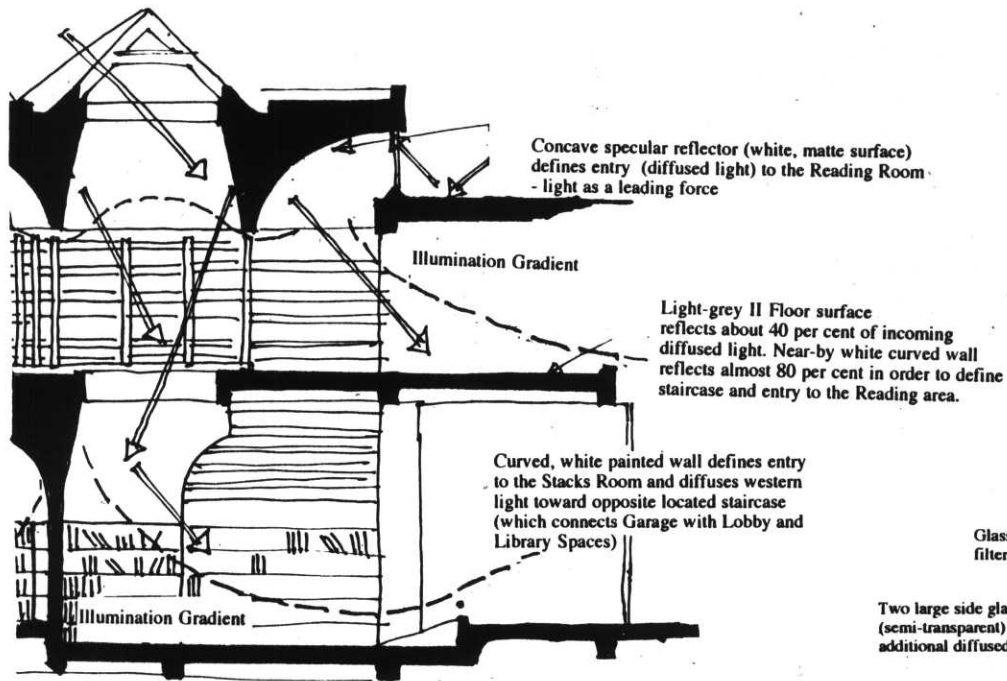

LIBRARY AND READING ROOM

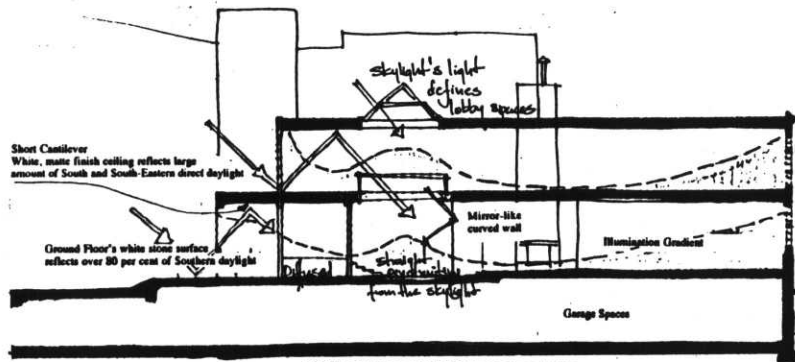
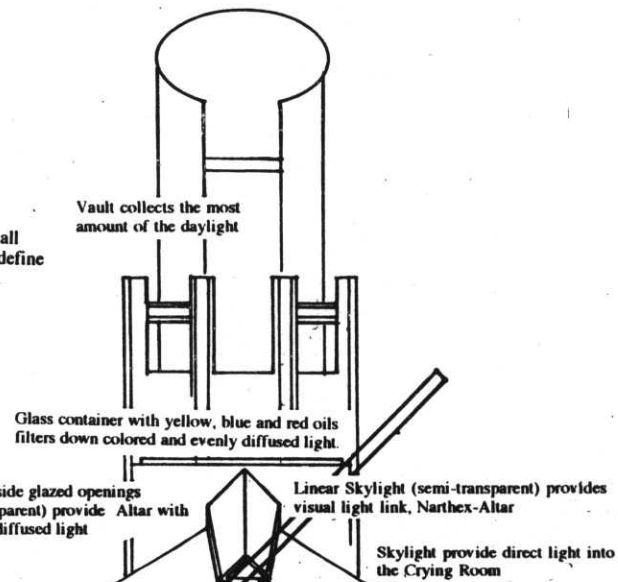

LOBBY AND WAITING ROOM SPACES SCHEME

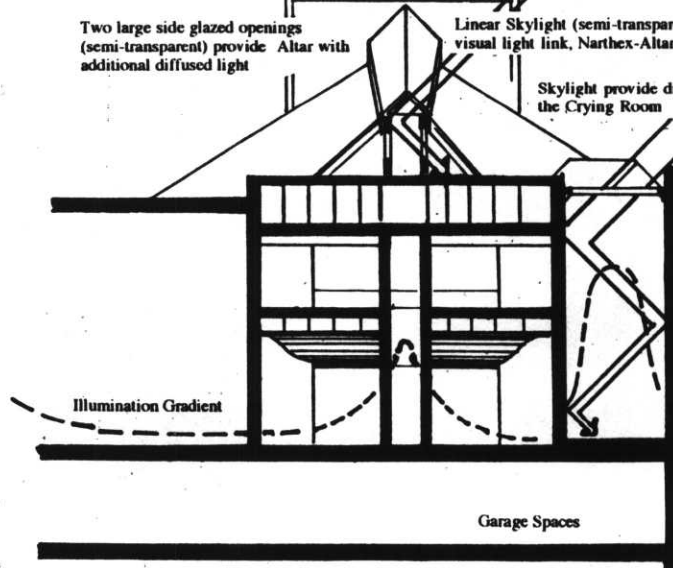

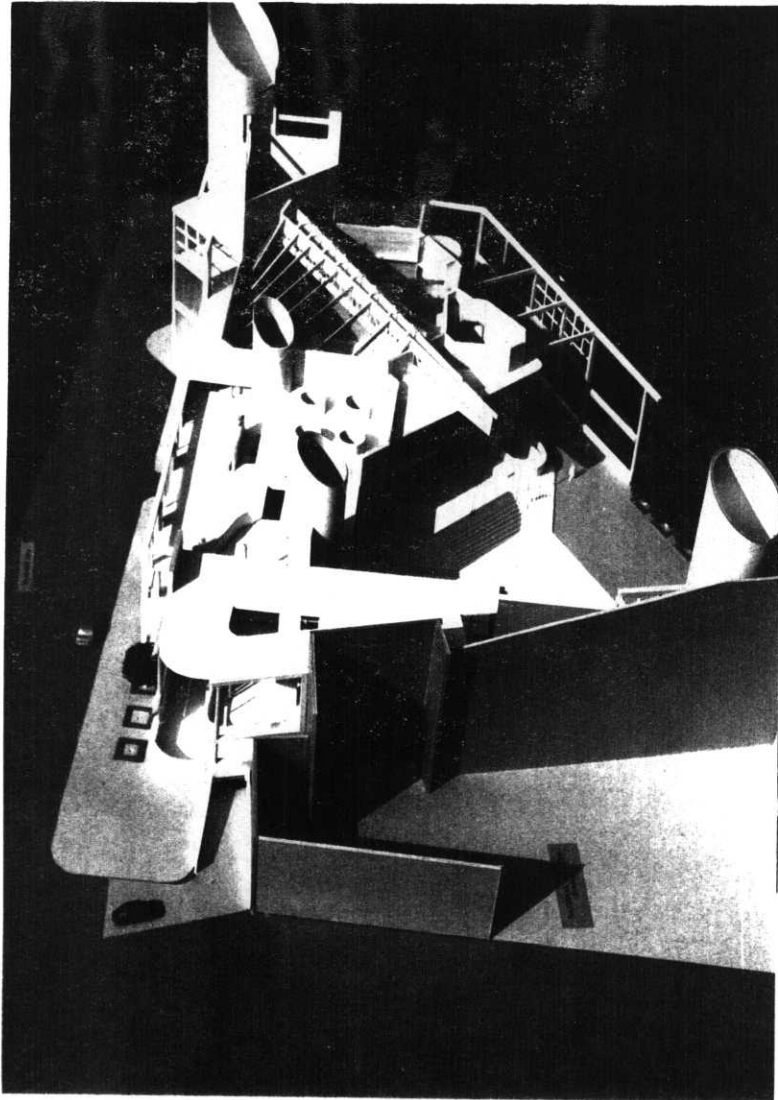

Lighting conditions in the Summer (late afternoon): daylight easily penetrates the Library and the Reading Room through large louvered openings (venetian blinds). The courtyard is mostly shades, the Light Tower and the Altar's extended walls still collect Western sunlight.

Lighting conditions in the Winter (late afternoon): daylight still penetrates the Library and the Reading Room. The shaded Courtyard is illuminated by reflecting walls of the Lobby and the Sanctuary. Three Complex entries (Library, Lobby and Sanctuary) are clearly defined by illuminated interiors and external walls. Similar daylighting conditions can be observed nearly throughout the whole year.

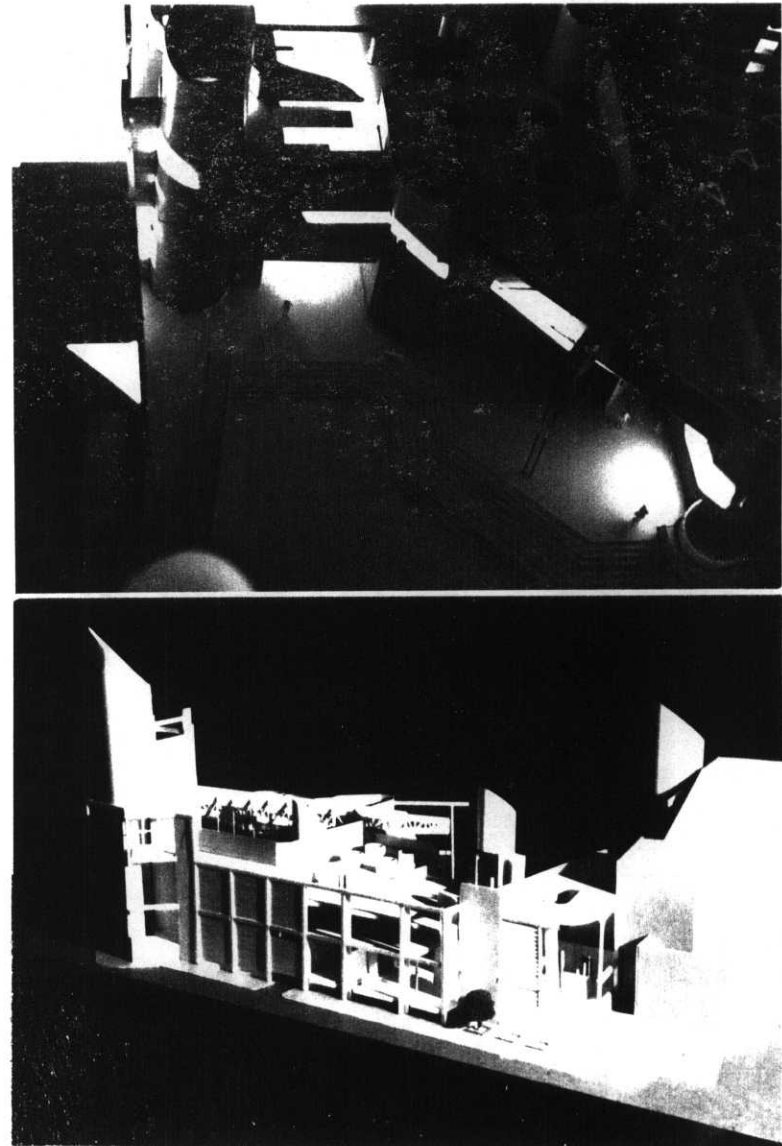

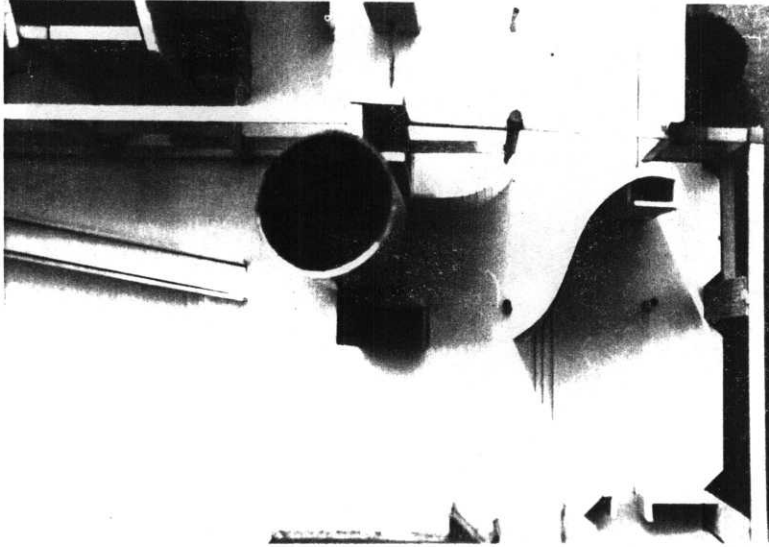

The curved Fire Place wall works as a “parapet wall” redirecting Western sunlight toward the Reading Room (through the clerestory). The roof surface and parapet wall are painted white to increase illumination level. Large space of Reading Room requires brighter ratios of well diffused light than the Sanctuary, the Meeting Room, the Auditorium or the Library below.

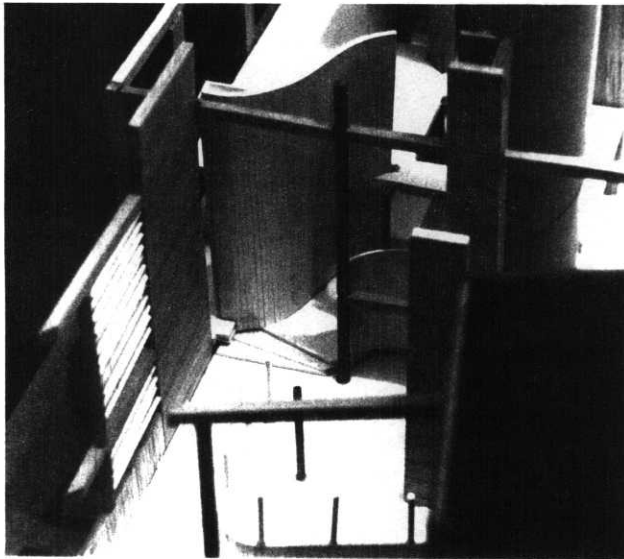

Extended above the Lobby levels, the curved Fire Place wall diffuses light towards the Lobby staircase and defines the spatial connection of the Lobby-Library and the Lobby-Reading Room spaces.

The Lobby's wide skylight and overhang allow daylight to directionally define the spatial and communicative importance of this space.

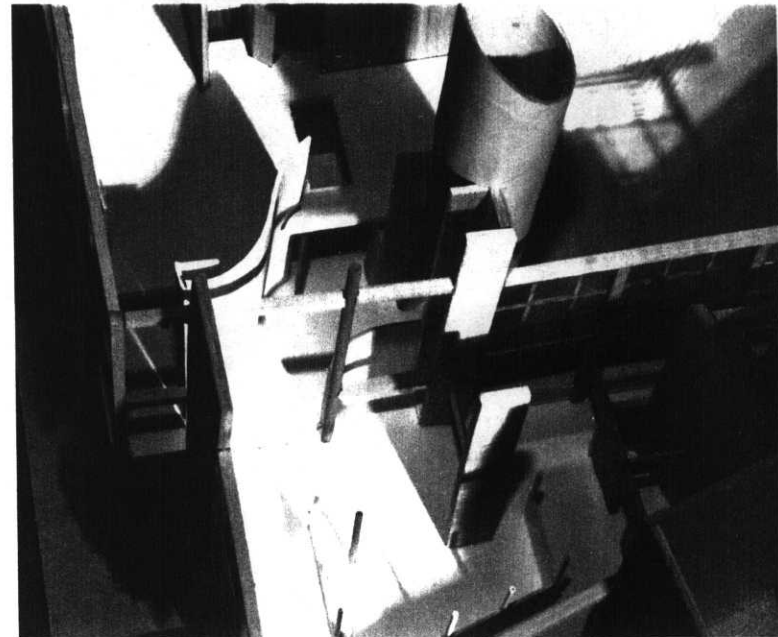
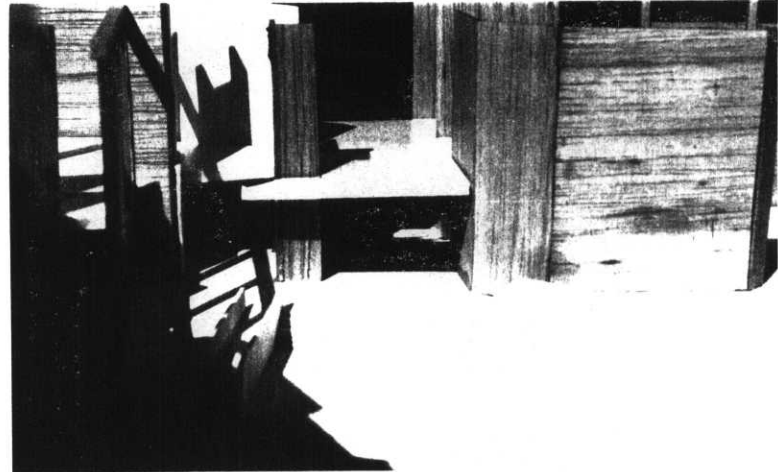

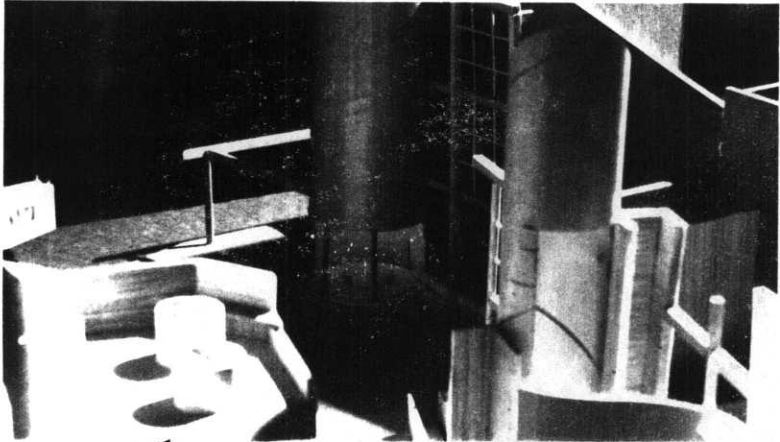

The Chapel's Tower is a visual and urban joint of this Church Complex. Together with the Sanctuary's Light Tower, it is illuminated 24 hours a day. The Courtyard is an important element which spatially organizes the whole design.

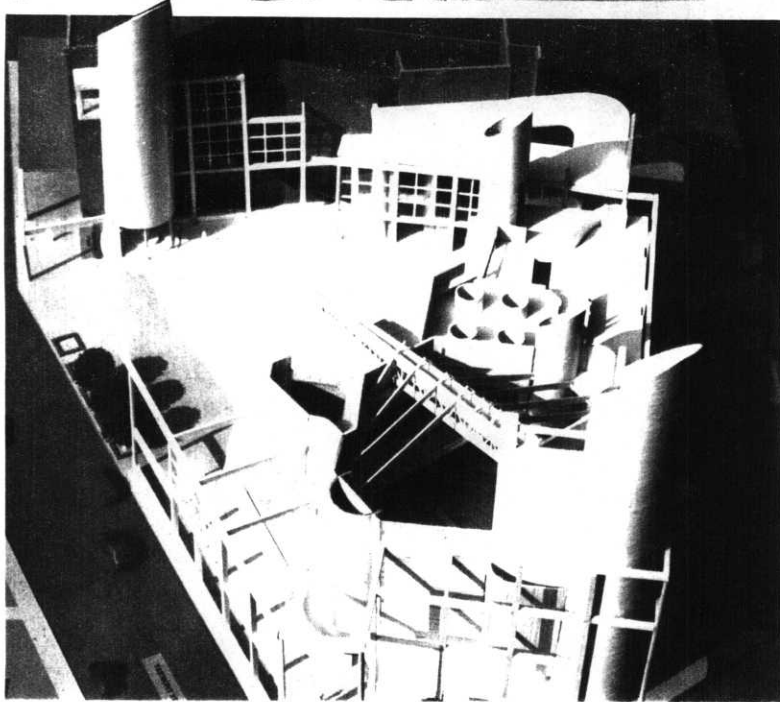

The pool of water which reflects daylight, surrounds the South-East part of the Sanctuary. It provides the Sanctuary with well diffused light.



Additionally, side Altar is designed on the southern Sanctuary's facade; and faces Tremont Street. It is located just above the reflecting pool of water and provided with artificial lighting 24 hours a day.

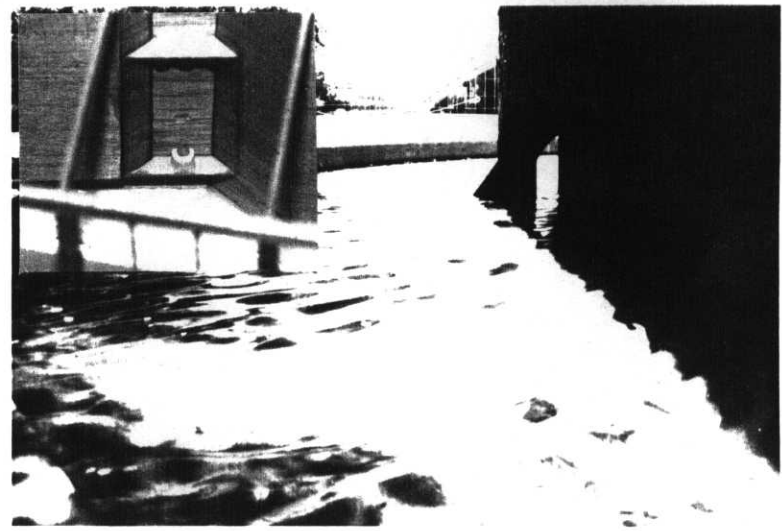

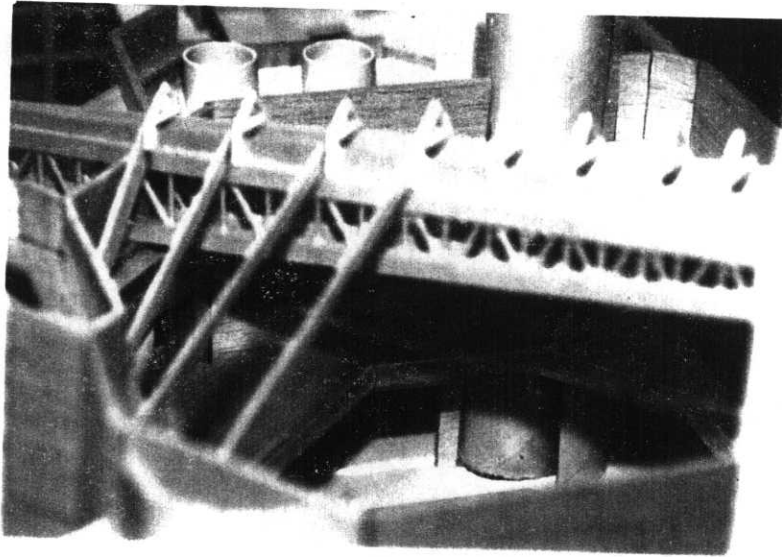

Additional exit diffuses light toward the Sanctuary space in order to balance the Baptistry's illumination and defines internal communication. The Choir Balcony is visually connected with the Auditorium for better orientation purposes.

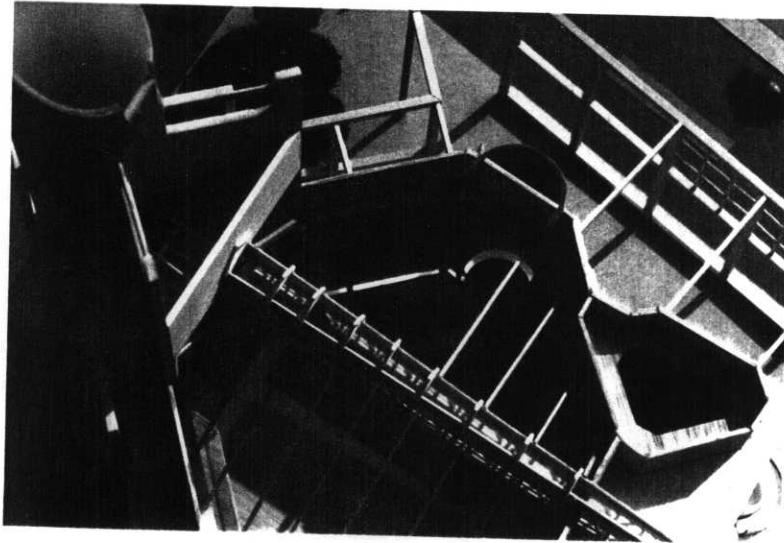

The Baptistry receives well diffused daylight from two sources: ceiling-to-wall narrow gap and through a similar gap on the floor level (this light is reflected from pool of water). This space's light quality is mysterious and suits the Baptistry function well.

Top view of a Church complex .
Sunlight conditions: mid Spring/Fall, time: 10.15 in the morning.

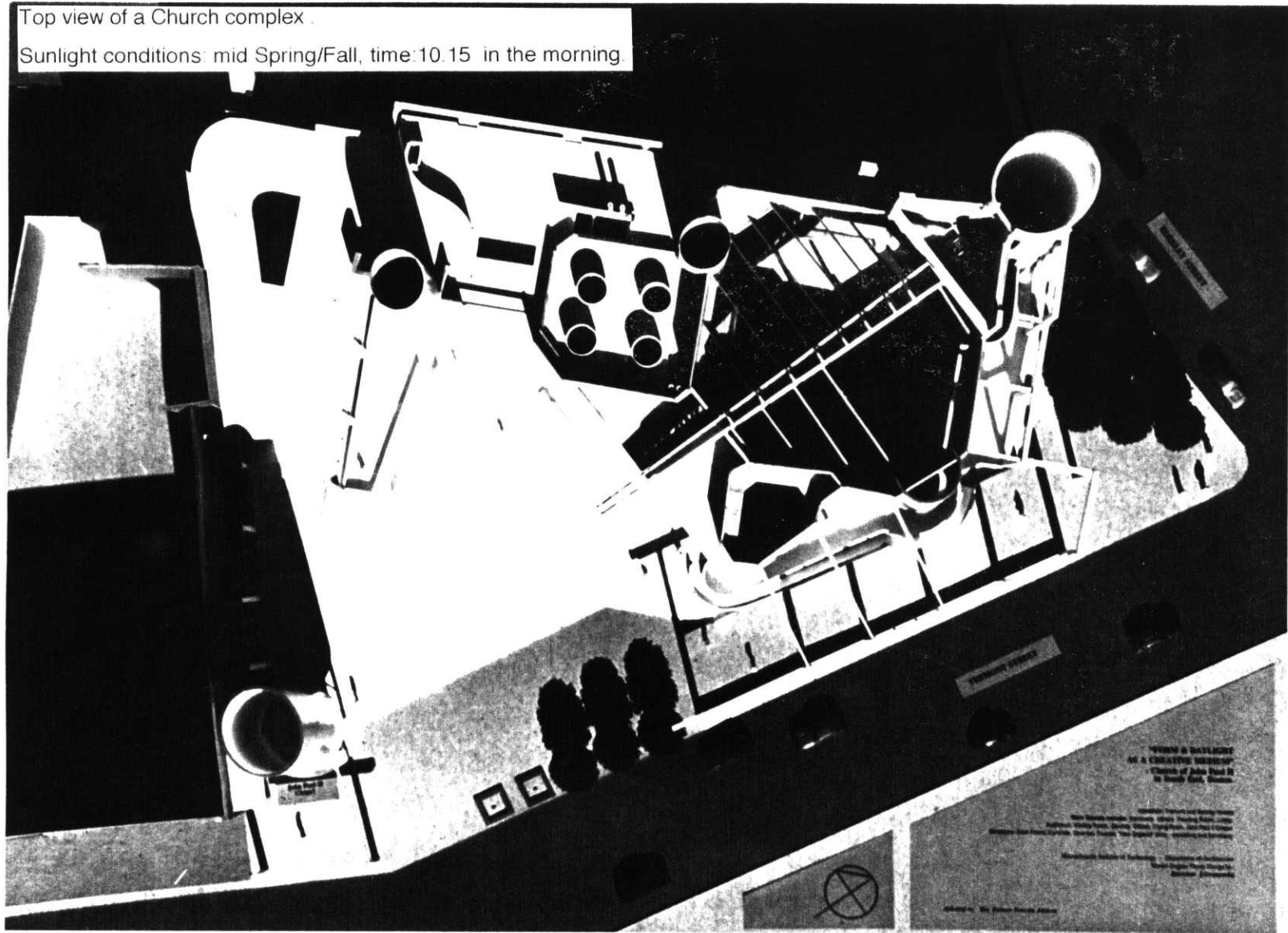

SANCTUARY'S DAYLIGHTING:

..." The Church is full of light ... you would declare that the place is not lighted by the sun from without, but the rays are produced within itself."

..." From the lightness of the building it does not appear to rest upon a solid foundation, but to cover the place beneath as though it were suspended from heaven by the fabled golden chain."

Justinian about Hagia Sophia

Daylighting scheme of the Sanctuary with Narthex and the Altar (next page).

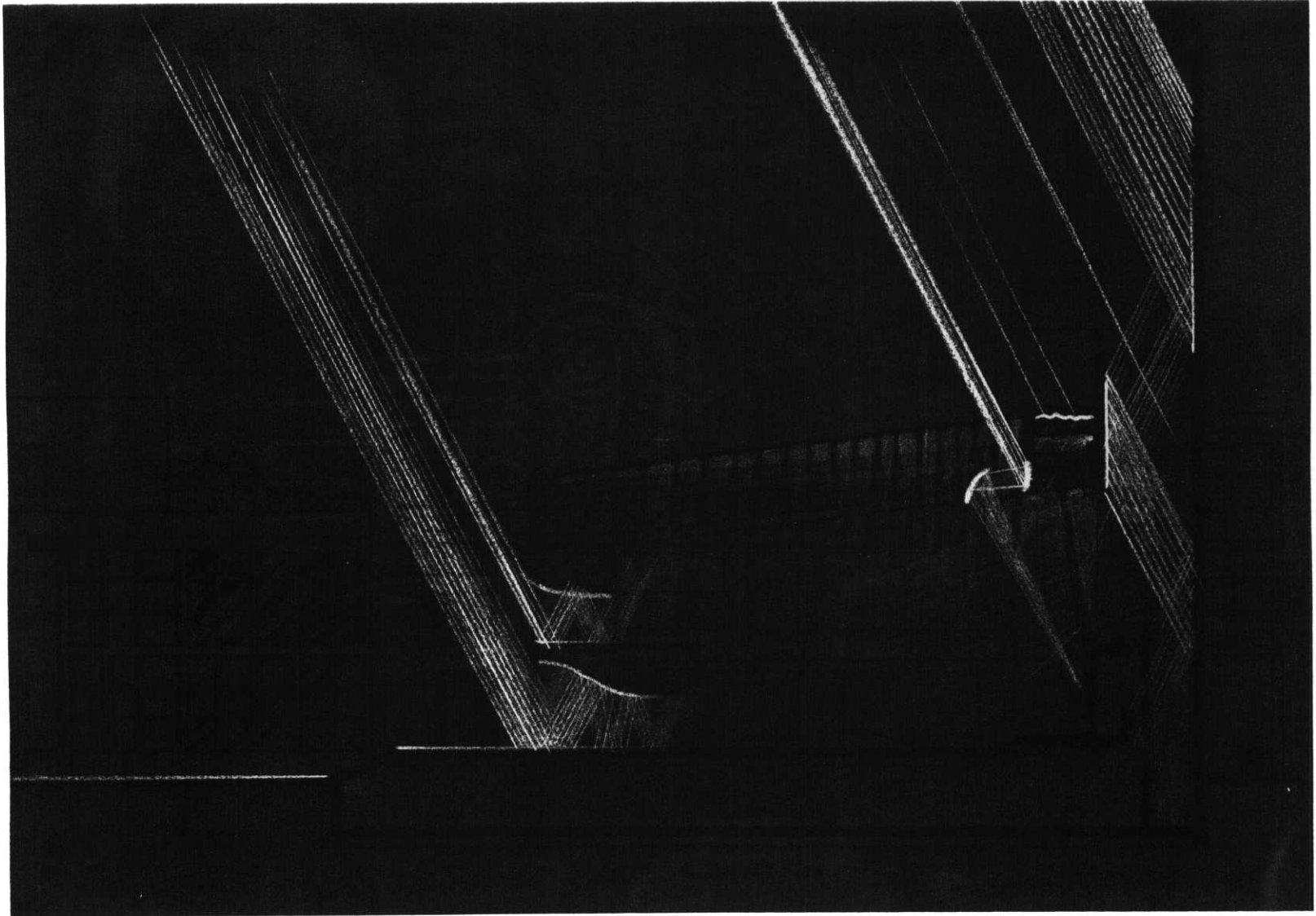

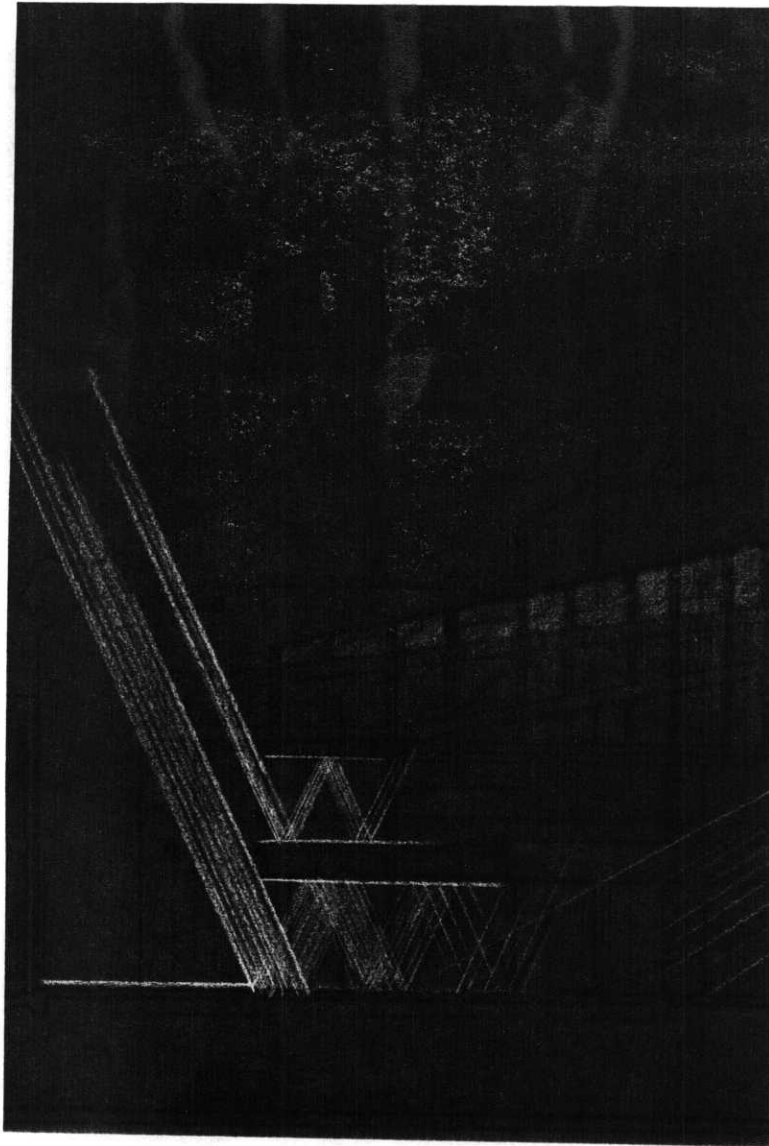

The previous design's entry and the second floor overhang ceilings were flat and perpendicular to the ground floor's surface. This allowed the large amounts of daylight to penetrate the Sanctuary's space. In order to limit the level of light illuminance in the Narthex and the above located Choir Balcony, curved vault-like ceilings were designed. These, finished in dark wood, ceilings absorb over a half of the daylight illumination. The Narthex (entry) vault is shaped in a way to double the light journey before it reaches the Sanctuary's space (see previous and next pages).

The Sanctuary's wide entry (the Narthex and Choir Balcony) is protected from intensive daylight illumination by two structural walls. They also limit undesirable visual contact between the Sanctuary and the Courtyard (Tremont Street - photograph below).

Notice steel trusses which shaped the entry vault and the Balcony's overhang and helped reducing the level of illumination inside the spaces.

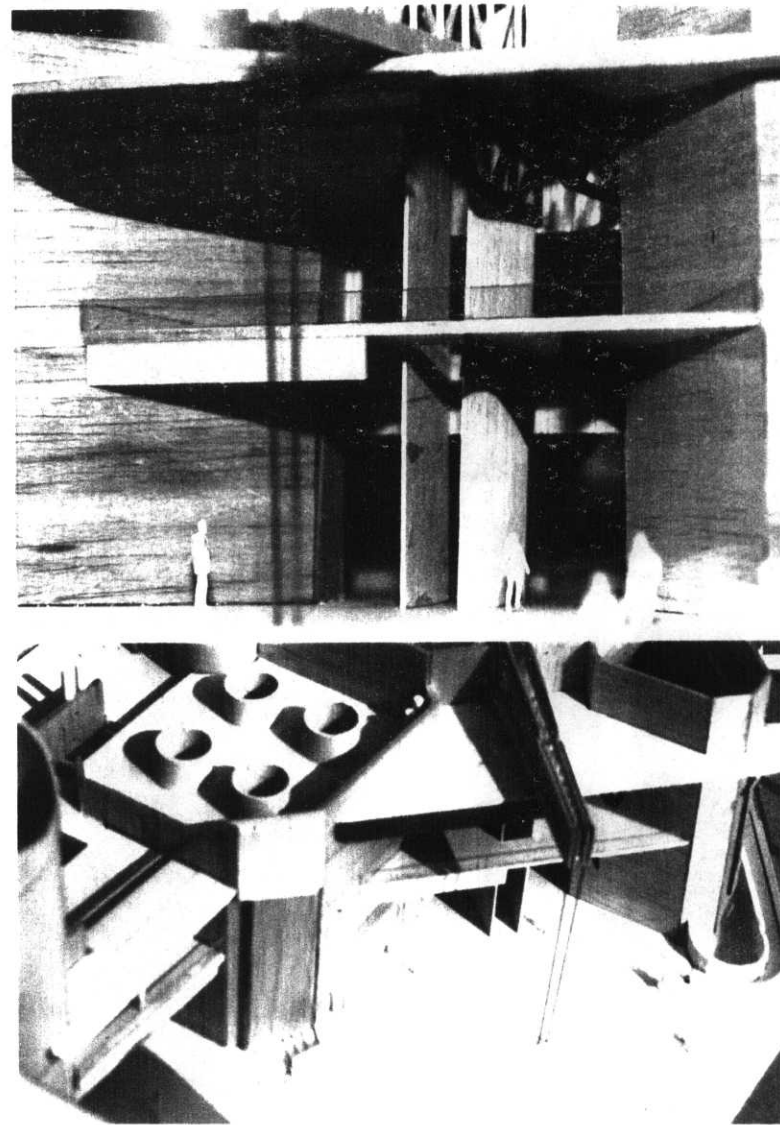

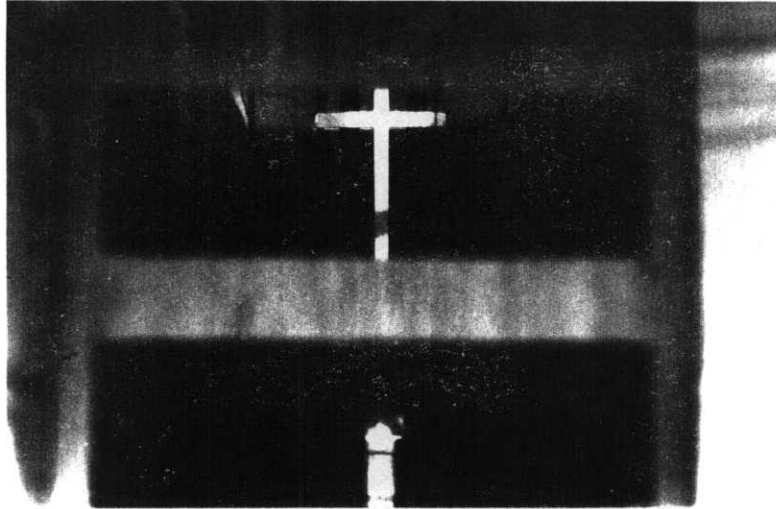

The Altar's hollowed cross receives its background illumination from the Light Tower's white painted walls. Priests' Preparation Room, the Sacristy, and the Altar are connected by the strip of diffused light coming from the floor's narrow openings. Through these glazed openings light is filtered in towards the Sanctuary's spaces (photograph below). This type of light has spatial, and proper for this space, mysterious qualities.

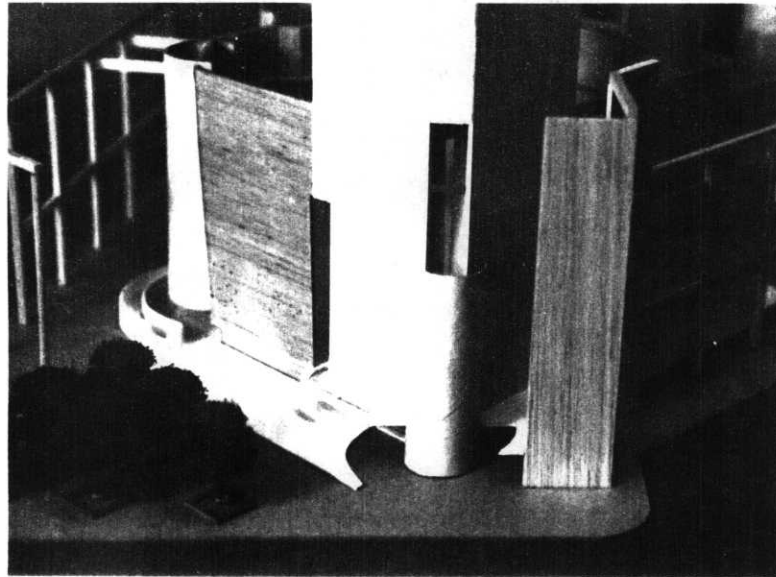

The Altar's white-washed structural walls extend well above the roof level and redirect daylight toward the Sanctuary. Light is diffused by the rough, white walls' surface, and receives its rainbow colors from the translucent glass container, which is located above the Altar. The container is filled with yellow, red and blue colored oils to create a pleasant glare on the Altar's internal walls and a contrast for the cross's white light.

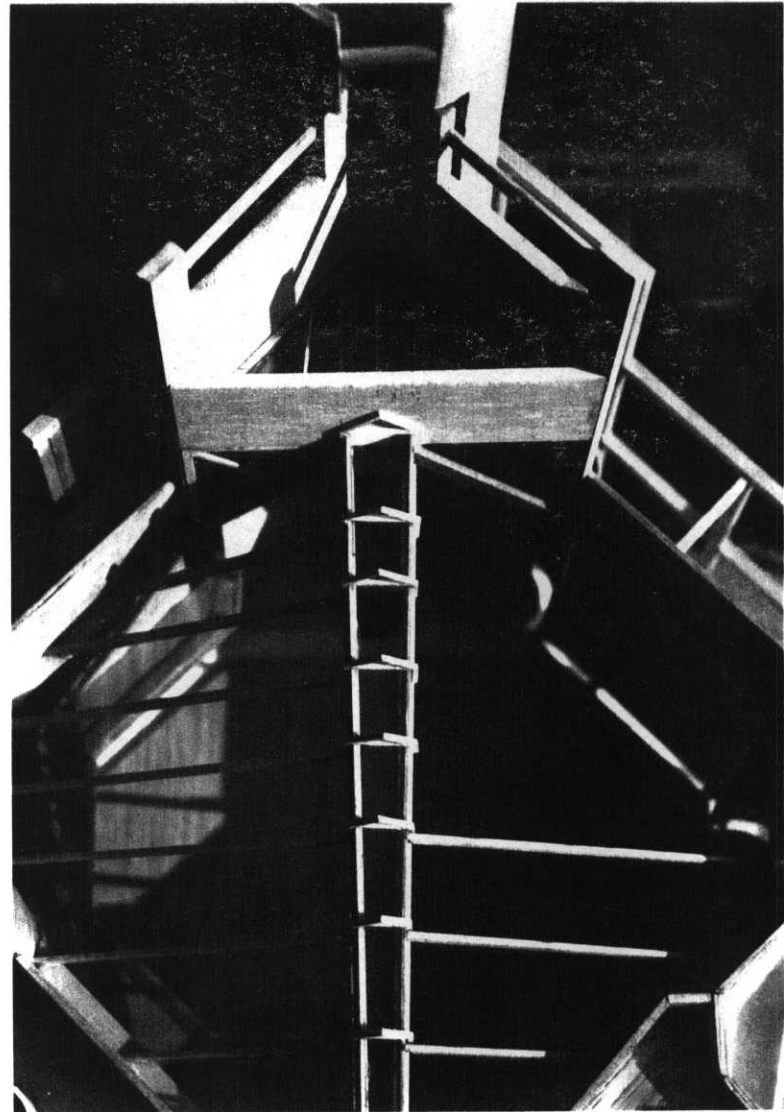

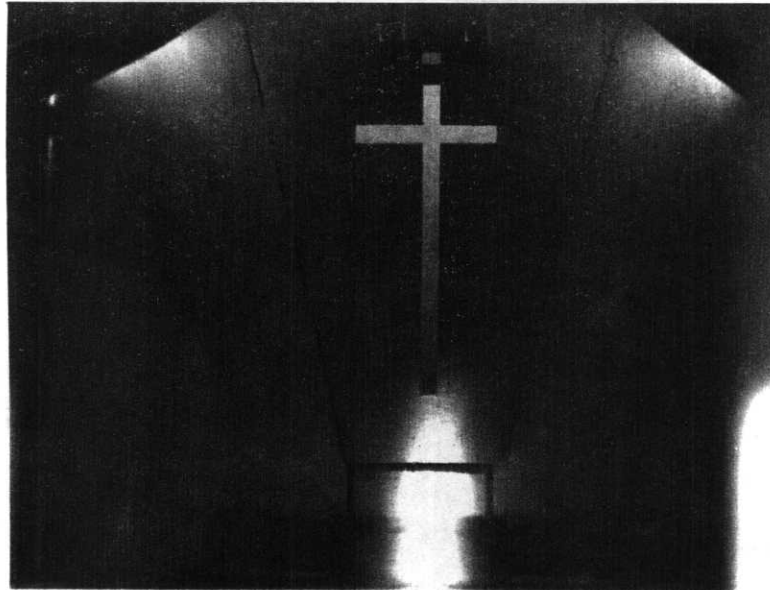
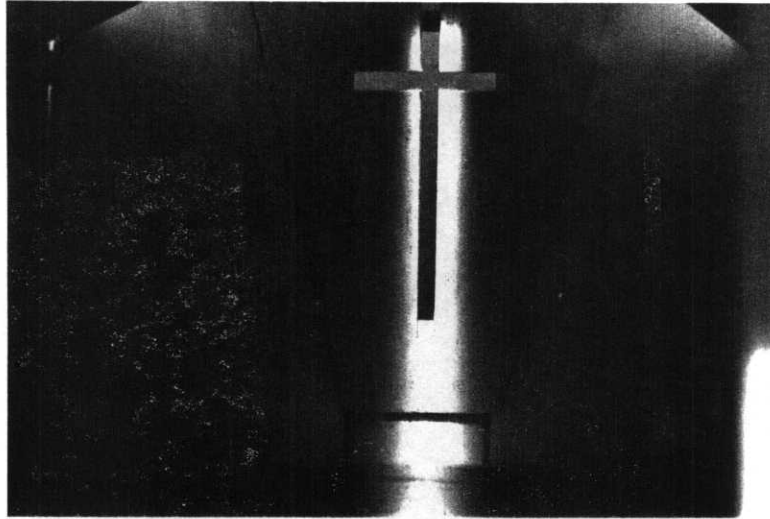

The Altar's semi-transparent windows provide the space with additional light. This well diffused light does not create any undesirable shadows on the Altars' walls (see the photo of the Sanctuary's physical light model).

Problematic, strip of strong daylight coming down from the skylight is avoided by using semi-transparent glazing; see photos.

Precisely at MIDDAY, a beam of daylight, which is controlled by two tracking mirrors reaches the place where the Tabernacle is placed.

Placed between the trusses, two automatically controlled tracking mirrors redirect beam of sunlight towards the Tabernacle. This part of the skylight where sunlight reaches the mirrors is glazed by the regular, clear window glass. The rest of the skylight's glazing is tinted from 50 (Narthex area) to 10 (Altar area) percent.

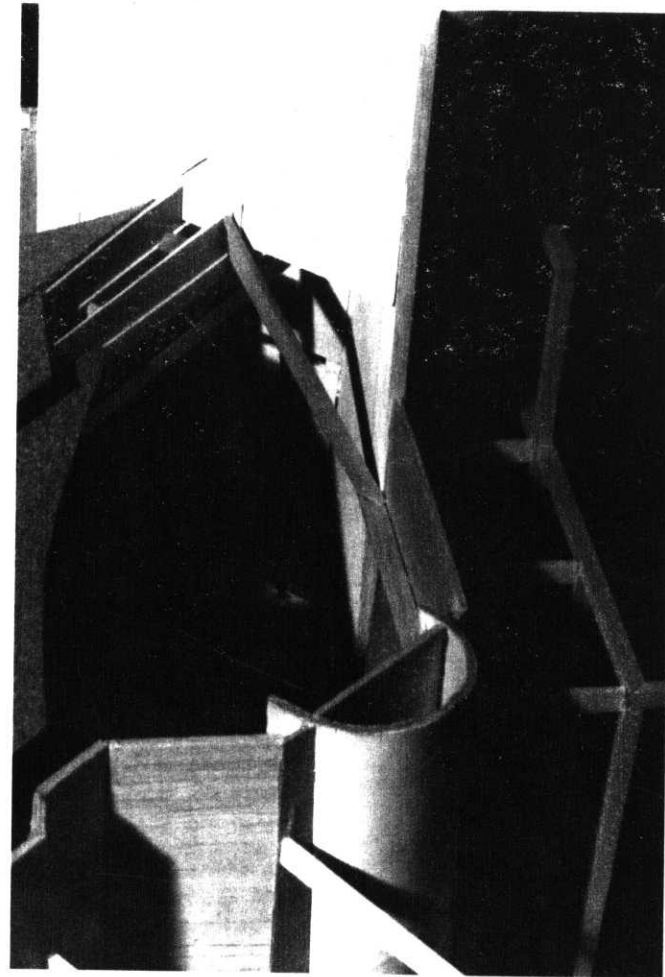

PLANS AND DRAWINGS:

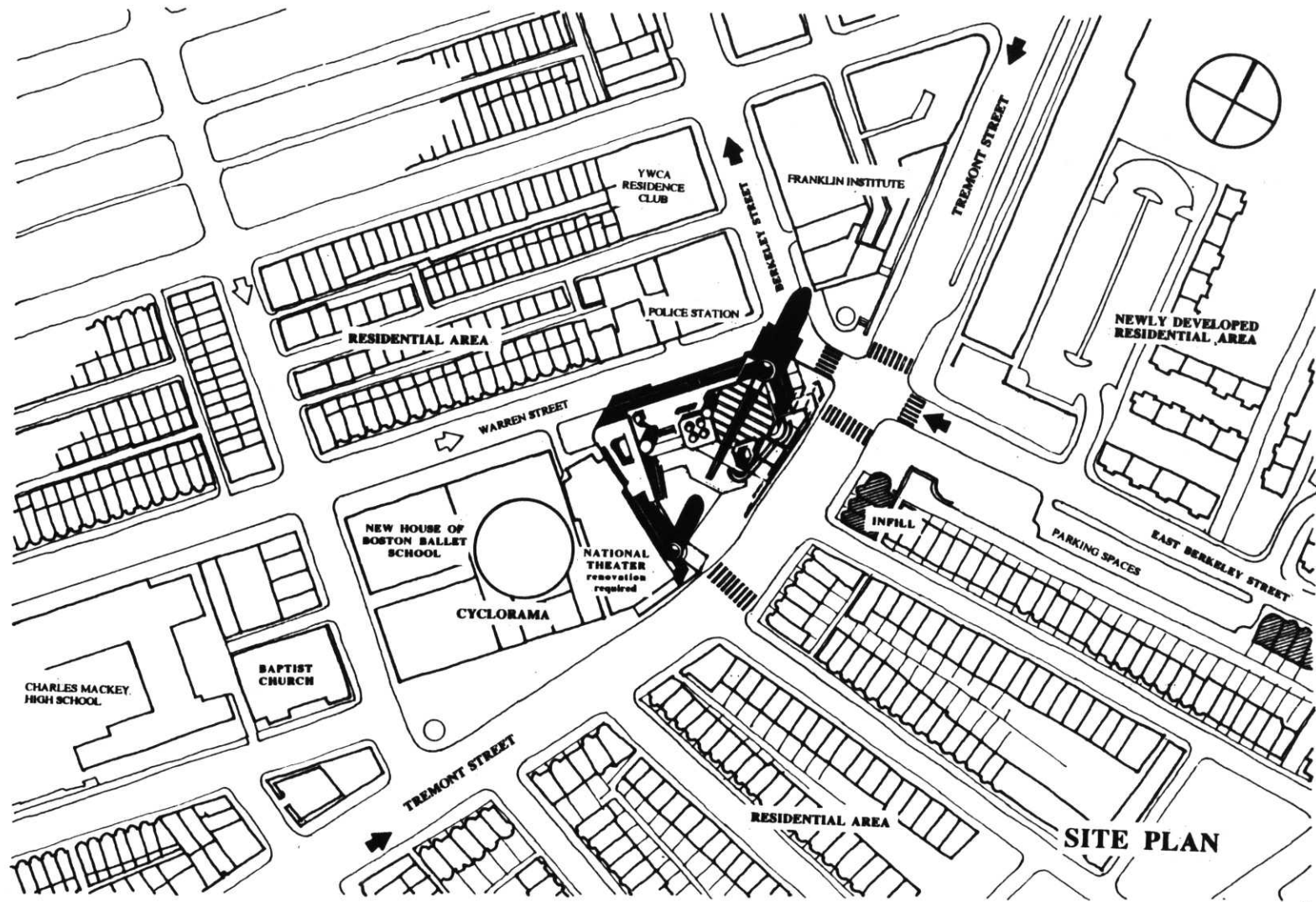

FIRST FLOOR PLAN:

- EXISTING NATIONAL THEATER
- JOHN PAUL II CHAPEL
- LIBRARY WITH STACK ROOM
- LIBRARY'S OFFICE SPACES
- LOBBY
- MEETING ROOM WITH CAFE
- AUDITORIUM
- SMALL HALL
- SANCTUARY
- BAPTISTERY
- CRYING ROOM

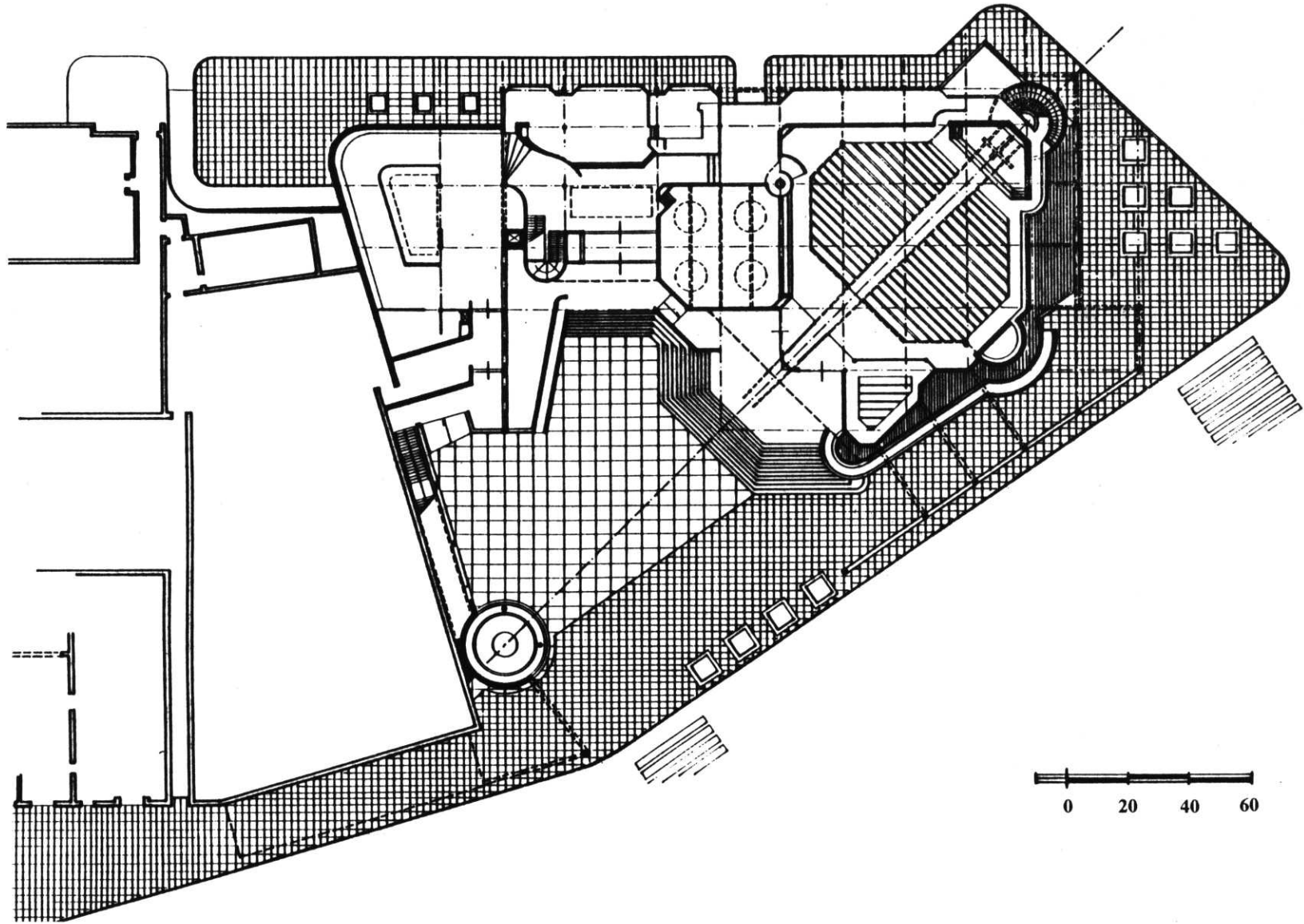

SECOND FLOOR PLAN:

- READING ROOM
- STORAGE SPACE
- OFFICE SPACES
- SMALL HALL II
- HALLWAY II
- CHOIR BALCONY
- PRIEST'S OFFICE SPACE

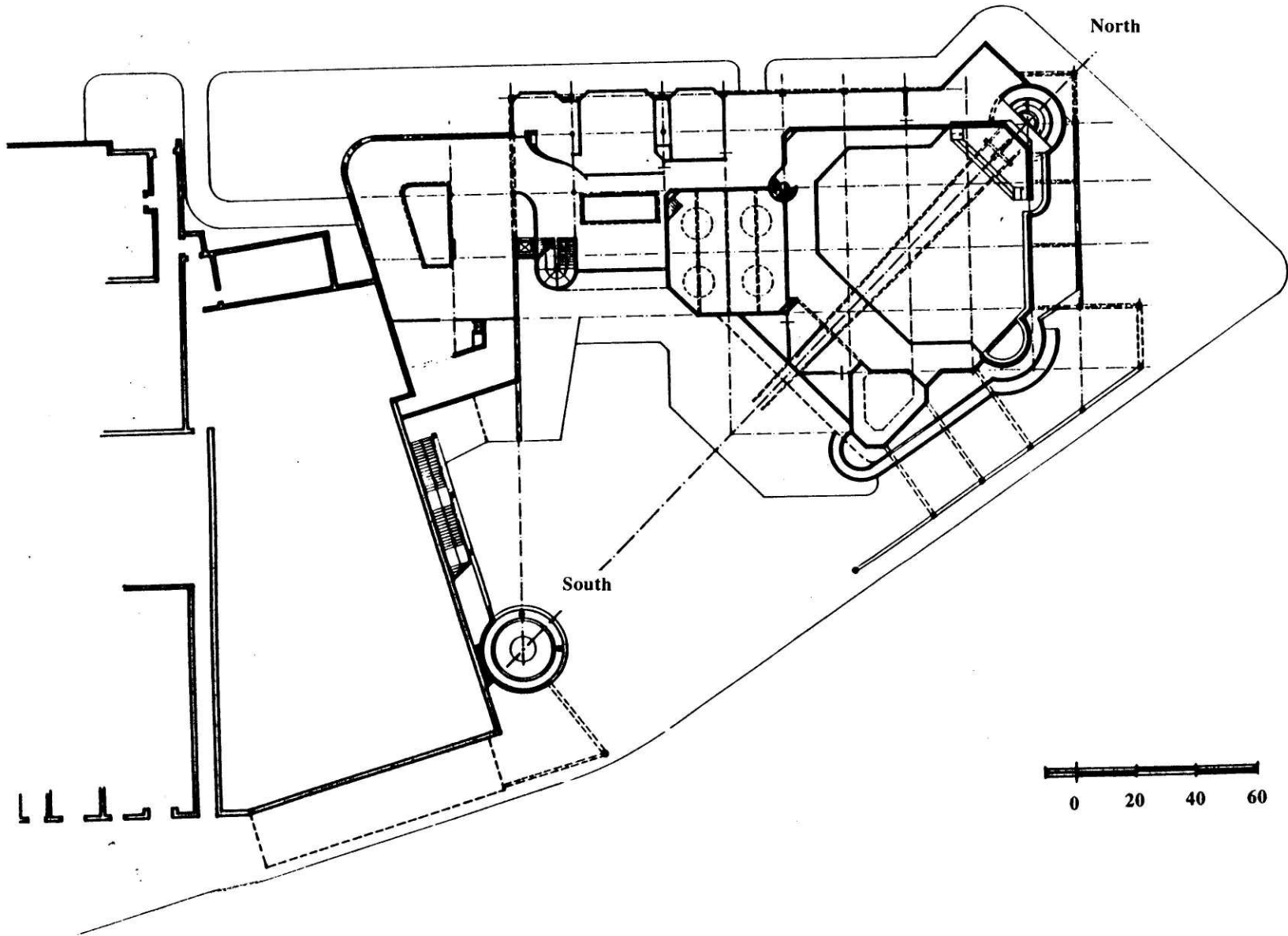

**SOUTH ELEVATION
AND SANCTUARY CROSS-SECTION**

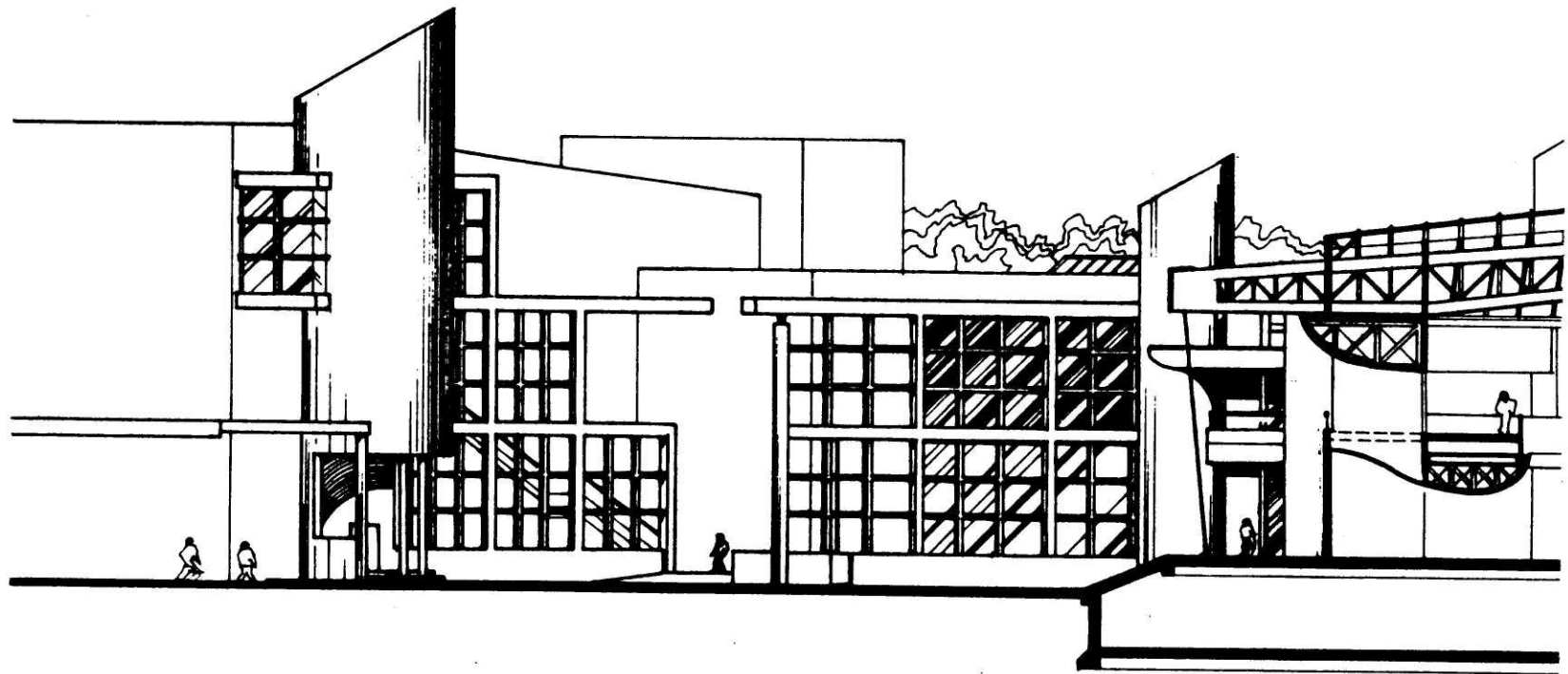

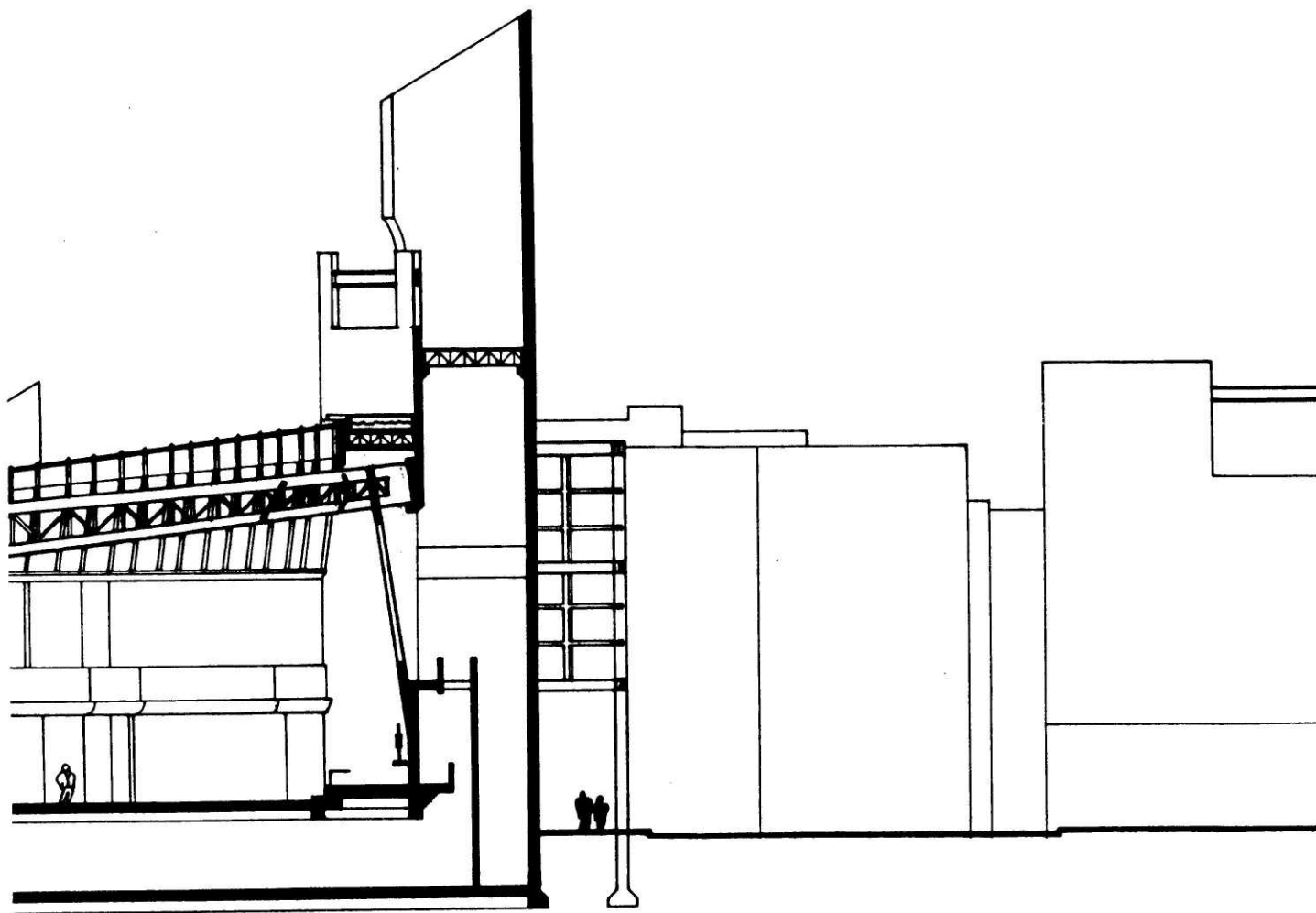

**SANCTUARY'S ENTRY AND CRYING
ROOM CROSS-SECTION**

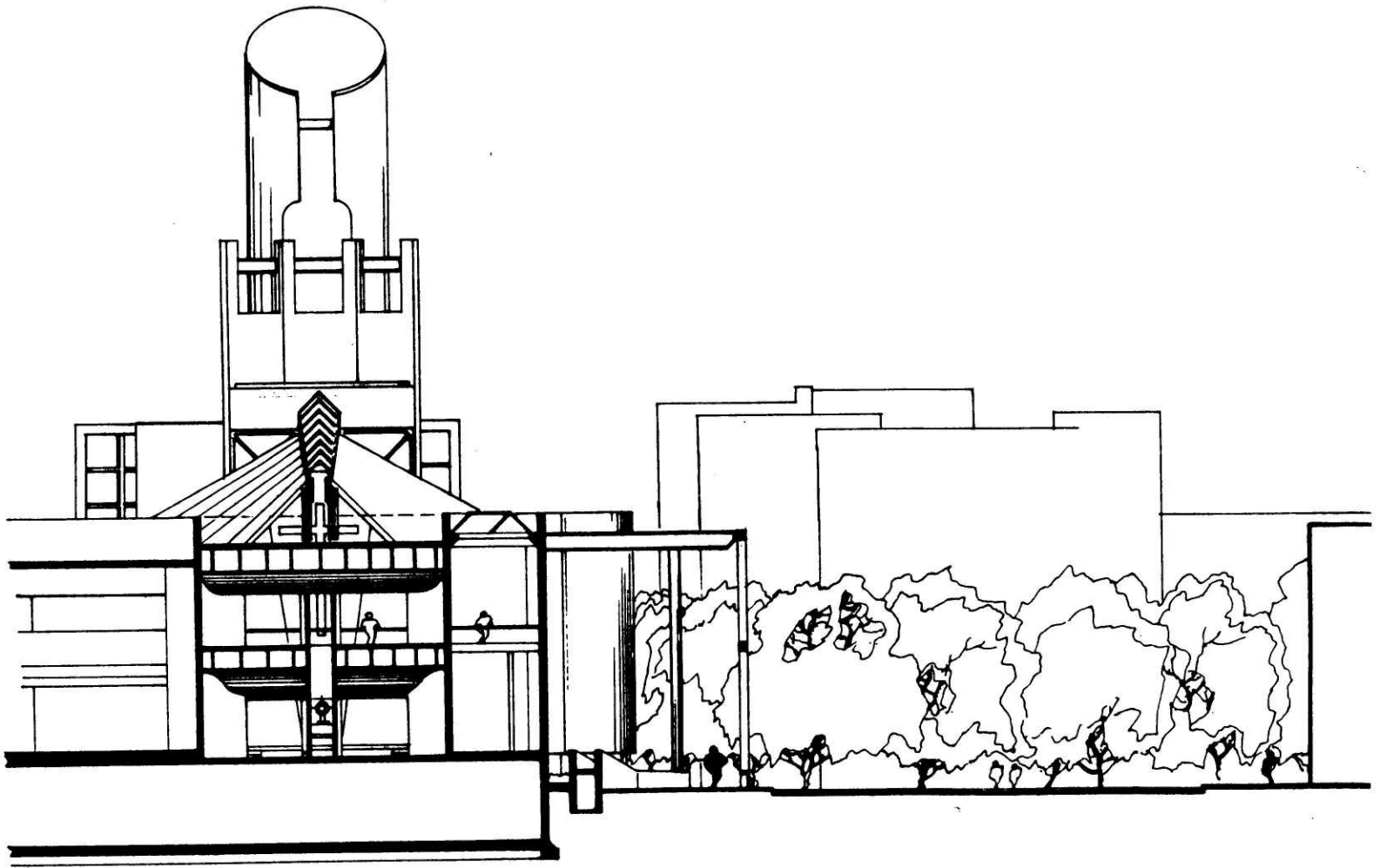

**LIBRARY, READING ROOM AND
LOBBY CROSS-SECTION:
DAYLIGHT STUDY**

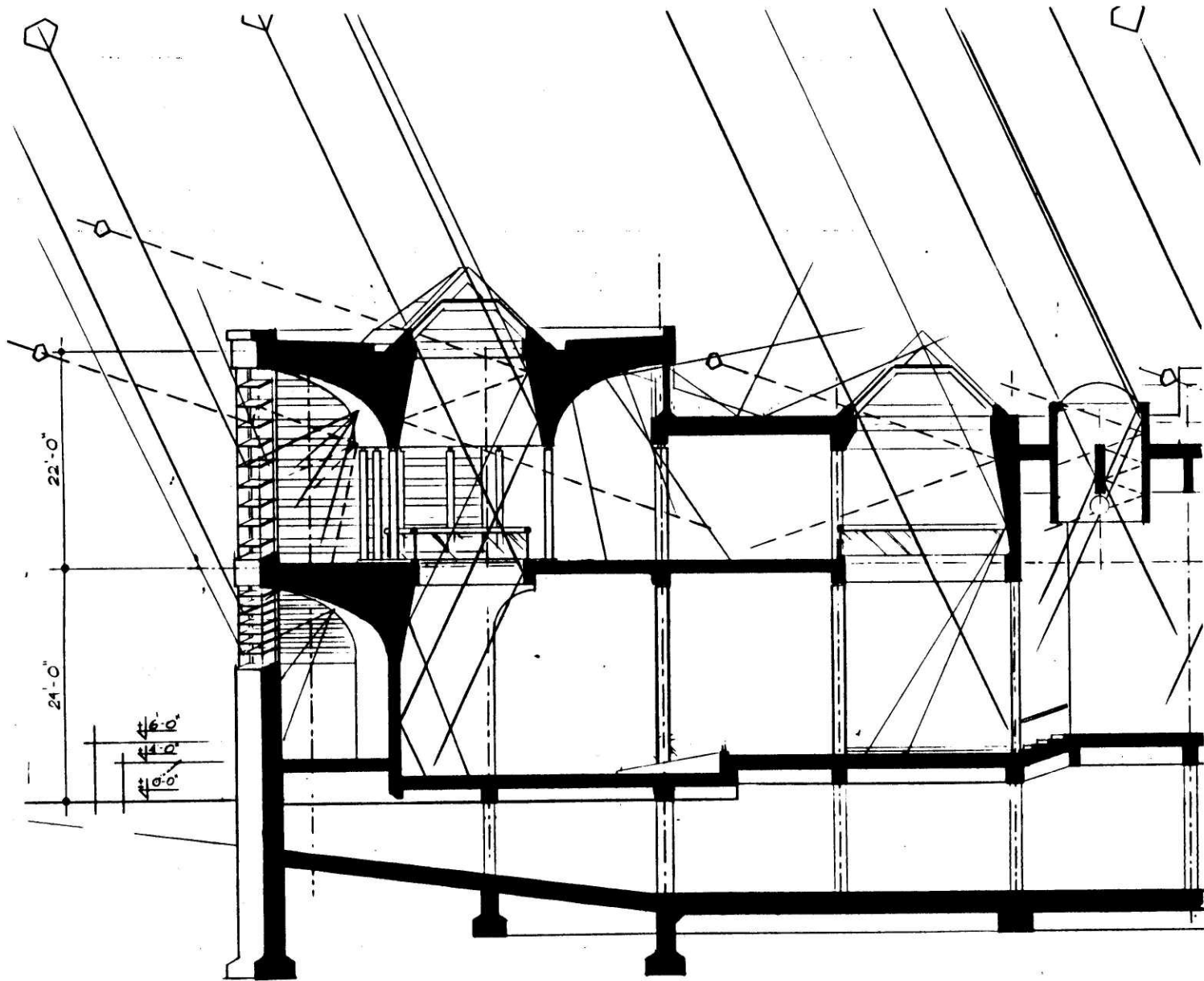

**SANCTUARY CROSS-SECTION:
DAYLIGHT STUDY**

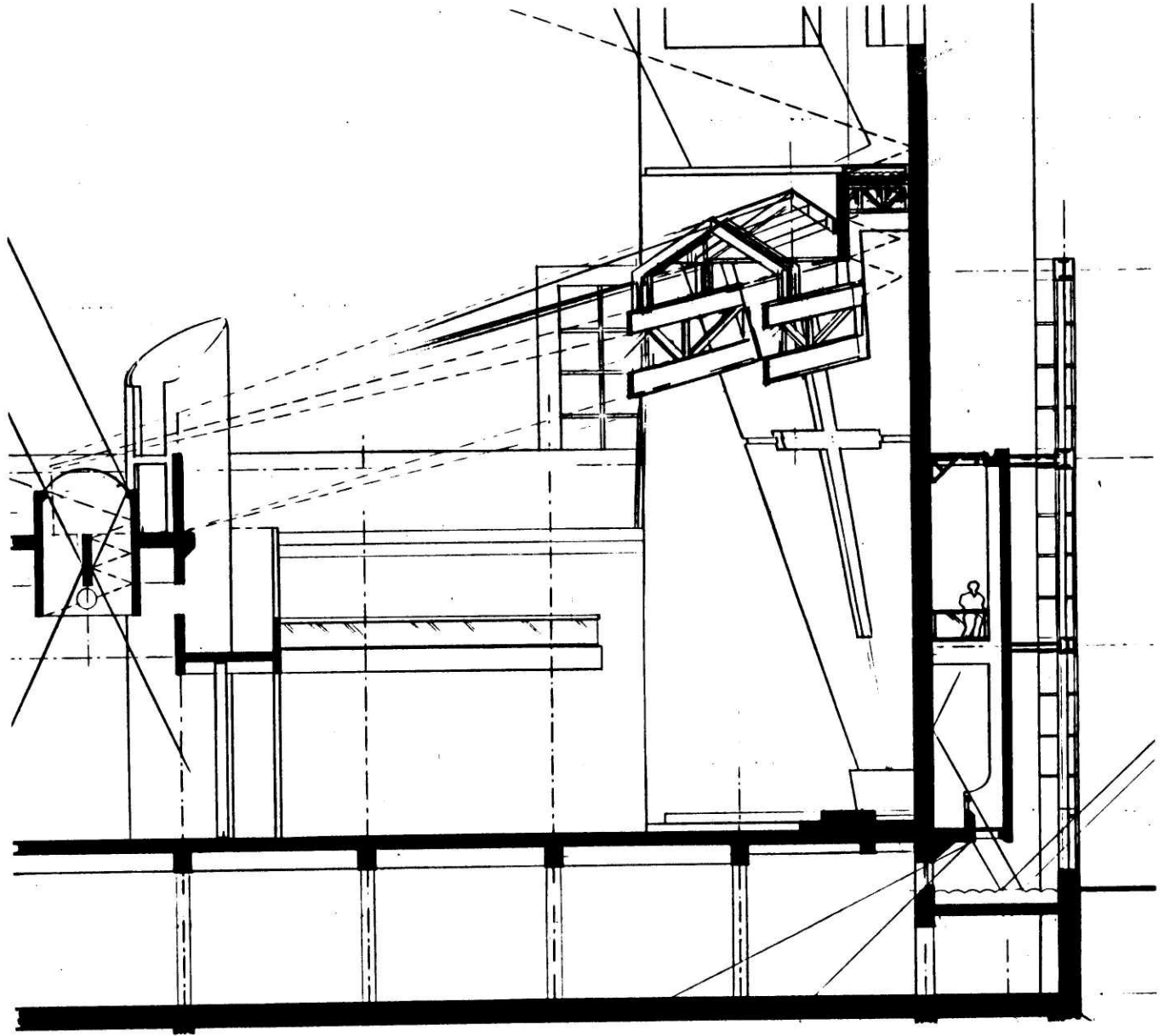

PROGRAM:

BREAKDOWN OF REQUIRED SPACES

SACRED:

Sanctuary	4000 SF
Narthex	1050 SF
Apse & Altar	580 SF
Baptistery	220 SF
Sacristy with Robing Room	370 SF
Choir Balcony	1620 SF
Pope's Chapel	360 SF
Crying Room	465 SF
<u>TOTAL</u>	<u>8675 SF</u>

COMMUNAL:

Lobby	810 SF
Auditorium	1440 SF
Library & Reading Room	3150 SF
Waiting Room	585 SF
Cafe	410 SF

Small Hall 630 SF

TOTAL 7025 SF

SERVICE:

Machine Room 1200 SF

Electrical Room 285 SF

Storages 2 @ 110 SF

Offices 2 @ 190 SF

Custodian's Office 340 SF

Priests' Rooms 2 @ 300 SF

Restrooms: 2 @ 200 SF

1 @ 55 SF

Library Office/Storage 360 SF

Reading Room Office 300 SF

TOTAL 4140 SF

TOTAL PROGRAM AREA (+15% access) 22800 SF

ADDITIONALLY - 90 GARAGE CAR SPACES 18000 SF

PART FOUR: Reference
SOURCES OF ILLUSTRATION:

- PAGE 001: Author, Model Photograph.
- PAGE 009: Murray, David, *"Architecture and Shadow,"* University of Pennsylvania, Rizzoli, 1990. The Koshino House.
- PAGE 011: Murray, David, *"Architecture and Shadow,"* University of Pennsylvania, Rizzoli, 1990. The Koshino House.
- PAGE 013: Hopkinson, R. G., *"Sunlight in Buildings,"* in "Proceedings of the C.I.E. International Conference," April, 1965.
- PAGE 014: Egan, David M., *"Concepts in Architectural Lighting,"* New York, McGraw-Hill, 1983.
- PAGE 015: Author, Model Photographs
Lam, William M.C., *"Perception and Lighting as Formgivers for Architecture,"* New York, McGraw-Hill, 1977.
- PAGE 016: Egan, David M., *"Concepts in Architectural Lighting,"* New York, McGraw-Hill, 1983.
Lam, William M.C., *"Perception and Lighting as Formgivers for Architecture,"* New York, McGraw-Hill, 1977.
- PAGE 017: Lam, William M.C., *"Sunlighting as a Formgiver for Architecture,"* New York, McGraw-Hill, 1990.
- PAGE 018: Olgyay, V. and Olgyay A., *"Solar Control and Shading Devices,"* Princeton, Princeton University Press, 1963.

- PAGE 019: Lam, William M.C., *"Sunlighting as a Formgiver for Architecture,"* New York, 1990.
- PAGE 020: Lam, William M.C., *"Sunlighting as a Formgiver for Architecture,"* New York, 1990.
- PAGE 021: Egan, David M., *"Concepts in Architectural Lighting,"* New York, McGraw-Hill, 1983.
- PAGE 022: Lam, William M.C., *"Sunlighting as a Formgiver for Architecture,"* New York, 1990.
- PAGE 023: Lam, William M.C., *"Sunlighting as a Formgiver for Architecture,"* New York, 1990.
- PAGE 025: Lam, William M.C., *"Sunlighting as a Formgiver for Architecture,"* New York, 1990.
- PAGE 026: E. Neufert, *"Podrecznik Projektowania Architektoniczno-Budowlanego,"* Arkady, Warszawa, 1980.
- PAGE 027: Egan, David M., *"Concepts in Architectural Lighting,"* New York, McGraw-Hill, 1983.
- PAGE 028: Hopkinson, R. G., *"Sunlight in Buildings,"* in "Proceedings of the C.I.E. International Conference," April, 1965.
- PAGE 029: Egan, David M., *"Concepts in Architectural Lighting,"* New York, McGraw-Hill, 1983.

- PAGE 030:** Lam, William M.C., *"Sunlighting as a Formgiver for Architecture,"* New York, 1990.
- PAGE 031:** Author, Sunlighting Analysis Model, Photograph.
- PAGE 033:** Moore, Fuller, *"Daylighting: Six Aalto Libraries,"* AIA Journal, Vol.72, No.6, June 1983.
- PAGE 034:** Viipuri Library; Rotch Slide Collection, MIT.
- PAGE 035:** Rautatalo Building, Technical Institute; Rotch Slide Collection, MIT.
- PAGE 036:** Wolsburg Cultural Center, Rotch Library, MIT.
- PAGE 037:** Seinajoki Town Hall; Rotch Slide Collection, MIT.
- PAGE 038:** Seinajoki Library, Riola Parish Church; Rotch Slide Library, MIT.
- PAGE 039:** Otaniemi Library, Tech. Institute Auditorium; Rotch Slide Collection, MIT.
- PAGE 040:** Riola Parish Church, Rotch Library, MIT.
- PAGE 041:** Norre Uttrup Church - Sanctuary, Arkitektur DK.
- PAGE 042:** Norre Uttrup Church - Sanctuary, Arkitektur DK.

- PAGE 043: Saedden Church - Plan and Elevation Detail, Arkitektur DK.
- PAGE 044: Saedden Church - Interior Details, Arkitektur DK.
- PAGE 045: Saedden Church - Skylights, Arkitektur DK.
- PAGE 046: Bagsvaerd Church - Interior, "*Bagsvaerd Kirke*," Arkitektur DK, Nyhavn, Arkitektens Forlag, March 1982.
- PAGE 047: "*Bagsvaerd Kirke*," Arkitektur DK, Nyhavn, Arkitektens Forlag, March 1982.
- PAGE 048: Monastery of Sainte Marie de la Tourette - Sanctuary; Baker, Geoffrey H., "*Le Corbusier: An Analysis of Form*," London, Van Nostrand Reinhold Co., 1984.
- PAGE 049: Pastoor van Arskerk Kirke - Sanctuary and Cross-Sections; Rotch Slide Collection, MIT.
- PAGE 050: La Tourette - Sanctuary; Baker, Geoffrey H., "*Le Corbusier: An Analysis of Form*," London, Van Nostrand Reinhold Co., 1984.
- PAGE 051: Ronchamp Chapel; drawings by: Baker, Geoffrey H., "*Le Corbusier: An Analysis of Form*," .
- PAGE 052: Ronchamp Chapel; Light Tower

photograph from: Baker, Geoffrey H., *"Le Corbusier: An Analysis of Form."*

- PAGE 053: Ronchamp Chapel; drawings by: Baker, Geoffrey H., *"Le Corbusier: An Analysis of Form"*.
- PAGE 054: First Unitarian Church in Rochester, N.Y. - Sanctuary's Interior with Skylights; Rotch Slide Collection, MIT.
- PAGE 055: First Unitarian Church in Rochester, N.Y. - Sanctuary's Plan and Cross-Sections; Rotch Slide Collection, MIT.
- PAGE 056: Kimbell Art Museum - drawings; Mayers, Marshalls, *"Masters of Light: Louis I.Kahn,"* AIA Journal, Vol. 68, No.11, September 1979.
- PAGE 057: Kimbell Art Museum - Interior and Cross-Section *"Masters of Light: Louis I.Kahn,"* AIA Journal, Vol. 68, September 1979.
- PAGE 059: Author, Site Plan, Free-Hand Drawing.
- PAGE 060: Satellite Photograph; South End, Boston.
- PAGES 061-080: Author, Site and Model Photographs.
- PAGES 081-095: Author, Line Drawings and Diagrams.
- PAGES 096-111: Author, Model Photographs.
- PAGES 113-125: Author, Line Drawings and Diagrams.

BIBLIOGRAPHY:

"...even a space Intended to be dark should have just enough light from some mysterlous opening to tell how dark It really is."

Louis I.Kahn

Arnheim, Rudolf, "*The Dynamics of Architectural Form*," Berkeley, University of California Press, 1977.

Alexander, Christopher, "*A Pattern Language*," New York, Oxford University Press, 1977.

Baker, Geoffrey H., "*Le Corbusier: An Analysis of Form*," London, Van Nostrand Reinhold Co., 1984.

Carlberg, Dennis Brian, "*Light and Form*," Master of Architecture Thesis, M.I.T. , 1984.

Egan, David M., "*Concepts in Architectural Lighting*," New York, McGraw-Hill, 1983.

Evans, Benjamin H., "*Daylight in Architecture*," New York, McGraw-Hill, 1981.

Fleig, Karl, "*Alvar Aalto 1922-1962*," New York, Wittenborn, 1963.

Fleig, Karl, "*Alvar Aalto 1963-1970*," Praeger, 1971.

Hopkinson, R. G., "*Sunlight in Buildings*," in "Proceedings of the C.I.E. International Conference," April, 1965.

Kohler, Walter, "*Lighting in Architecture*," New York, Reinhold Publishing Corporation, 1959.

Lam, William M.C., "*Perception and Lighting as Formgivers for Architecture*," New York, McGraw-Hill, 1977.

Larson, Leslie, "*Lighting and Its Design*," Robert Teller and Sons, Whitney Library of Design, 1964.

Lobell, John, "*Between Silence and Light, Spirit in the Architecture of Louis I. Kahn*," Shambhala, Boston, 1979.

Marcus, Thomas A., "*Daylight with Insulation*," England, Baynard Press, 1960.

Mayers, Marshalls, "*Masters of Light: Louis I. Kahn*," AIA Journal, Vol. 68, No.11, September 1979.

Murray, David, "*Architecture and Shadow*," University of Pennsylvania, Rizzoli, 1990.

Moore, Fuller, "*Daylighting: Six Aalto Libraries*," AIA Journal, Vol.72, No.6, June 1983.

Olgay, V. and Olgay A., "*Solar Control and Shading Devices*," Princeton, Princeton University Press, 1963.

Peter, Richard C., "*Master of Light: Alvar Aalto*," American Institute of Architects Journal, Vol.68, No.11, September 1979.

Phillips, Derek, "*Lighting in Architectural Design*," New York, McGraw-Hill, 1964.

Plummer, Henry, "*Poetics of Light: A+U Architecture and Urbanism*" Extra Edition, December 1987.

Ronner, Heinz, "*Louis I. Kahn: Complete Works*," Boulder, Co., Westview Press, 1977.

Rosen, James E., "*Natural Daylighting and Energy Conservation*," M.I.T Thesis, 1981.

S.E.R.I. Solar Conservation Study, "*A New Prosperity - Building a Sustainable Energy Future*," Andover, 1981.

Smith, Kellogg Frank and Bertolone Fred, "*Bringing Interiors to Light, The Principles and Practices of Lighting Design*," Whitney Library of Design, New York, 1986.

Steele, Fritz, "*The Sense of Place*," Boston, CBI.

Tse, Brian, "*A Study of Natural Light for Museums: The Addition to the Fogg Art Museum in Cambridge, MA*," Master of Architecture Thesis, M.I.T, 1977.

Utzon, Jorn, "*Bagsvaerd Kirke*," Arkitektur DK, Nyhavn, Arkitektens Forlag, March 1982.

Vonier, Thomas, ed., "*Proceedings, International Daylighting Conference*," Washington, D.C.: American Institute of Architects Service Corporation, 1983.

for a friend of mine:

