

A System of  
Formal  
Analysis for  
Architectural  
Composition

by William Q. Hubbard, Jr.  
Bachelor of Architecture  
University of Virginia  
1970

submitted in partial fulfillment  
of the requirements for the degree of  
Master of Architecture in Advanced Studies  
at the  
MASSACHUSETTS INSTITUTE OF TECHNOLOGY  
June, 1976

Author \_\_\_\_\_

Department of Architecture  
May 7, 1976

Certified by \_\_\_\_\_

Stanford Anderson  
Professor of Architecture  
Thesis Supervisor

Accepted by \_\_\_\_\_

Eduardo Catalano  
Chairman,  
Departmental Committee on  
Graduate Students



For Stan Anderson, who muddied the waters of my too-clear vision and showed me the possibilities I'd missed.

# Contents

	3
Abstract_____	4
Introduction_____	6
First Presentation_____	10
Analysis_____	30
Renovation Prelude_____	50
Renovation_____	61
Addition Prelude_____	80
Addition_____	86
Second Presentation_____	118
Parallels_____	152
Opportunities_____	165
Dangers_____	172
Possibilities_____	185
Notes_____	192

# Abstract

Any building can be studied in a variety of ways, depending upon the information one wishes to draw from it. One of the central problems of architectural studies has been that architectural history looks at buildings with goals different from those of design and so does not produce information that addresses the concerns of the working architect. As a means of linking the two fields, this thesis proposes a model for the process of conceptualizing building form in which that form is seen as both an analyzable result and a designed signifier of the conditions the building was built to address. From this model the thesis develops a dual system in which the processes of analysis and design are conceived as the "playing back" of each other's methods.

The major ideas of the thesis are presented at two levels: the first presentation gives a quick overview of the conceptual model and the method of formal analysis based upon it. The workings of the method are then illustrated by an analysis of H. H. Richardson's Percy Browne house of 1881. The next sections show how the information from the analysis can be "played back" to produce designs consonant with the environment as built and analyzed. To do this, the situation of the Browne house is used as a base upon which is imposed a succession of hypothetical interventions of increasingly-greater



scope, each of which reflects certain new aspects brought to bear upon that situation--the first design being for a renovation, a rearranging of interior spaces that leaves the exterior relatively intact; the second being for an addition, in this case involving changes to both inside and outside. Following these designs, the second presentation of the model and method explores in greater depth several issues raised by the first presentation, in an attempt to provide a rigorous theoretical grounding for the system and its products.

# Introduction

To quote from my application for admission of December 1973:

I am interested in an architecture of significant form. I believe that architecture ought to signify to ordinary people meanings and associations beyond those simple signals that tell one how to function in a building. The purpose of my research would be to derive a process that would allow me to isolate meaningful architectural elements and incorporate them into building designs. . .

Still true. My concern with the needs and perceptions of "ordinary people" has guided this research from the beginning. And from the beginning this focus has raised the problem of judgement: how one can find a standard for analyzing and designing buildings that is convincing both for the practitioner and the user. Two polar possibilities exist, of course, both of them unsatisfactory: the standard that states, "Whatever the public likes is good" (besides leading to a potentially-dangerous affirmation of any existing state of affairs) represents both the designer/analyst's abdication of judgement (and therefore responsibility) and his romanticizing of "The Public;" conversely, the alternative pole of "I know what's best" poses the danger of irrelevance, and in any case, today's politics and economics prevent its application outside a narrow circle.

The problem's basis is that the public cannot know (and really doesn't care to know) how architects go about designing buildings, and yet the same public-- because it must use those buildings--

legitimately feels it has the right to accept or reject buildings according to its standards. In essence there exists an inevitable situation in which the public judges the products of a process without knowing how that process operates. As a way of addressing (but not "solving") this problem, I have adopted as a standard of judgement the legal concept of reasonableness: in law, the ordinary citizen does not have a detailed knowledge of the workings of jurisprudence but he does have a feeling for "what's fair;" it is not necessary that a complex legal decision immediately appear "fair" to him, but what is necessary--if the law is to remain publicly-acceptable and therefore valid--is that, if the fine points of the decision are explained to him, he will realize how his conception of fairness is subsumed within the wider perspective of jurisprudence. And likewise with the system of design and analysis I will be proposing in this study: the buildings that result from the system need not immediately appear "right" to a casual or naive observer, but the system must be constructed so that the person giving his "complicity" by viewing in the system's terms will not be confronted with the dilemma of a way of seeing radically opposed to his own, but instead will be "rewarded" by having his own perceptions confirmed and widened, subsumed within a "larger" way of seeing. Thus, a standard which the

designer and user can share is this test of reasonableness, the possibility of engendering the expansion of awareness that might be called the "Aha!" reaction.

In fact, this idea of a partial understanding fitting inside a wider conception governs the presentation of this study, for the system I will be presenting can be understood on two distinct levels; and for each level a certain type of information is necessary to explain the system at that level and to enable the reader to evaluate it. So, when seen purely as a usable "tool" for analyzing and designing buildings, the system should be evaluated on the basis of its "production," both buildings and analyses of buildings; the first half of this thesis will therefore present these "products" almost immediately, preceded only by that information necessary to impart an abridged but not misleading understanding of the workings of the system. But if the system is to be seen as more than just another personal work-method, it should give an understanding of the nature of architecture not seen before--and show how analyses under the system reveal this nature and how design reflects it; the latter half of the thesis attempts to do this by presenting the system a second time, in a fuller fashion, addressing issues skipped in the necessarily cursory initial presentation. The two presentations will be tied together by notes in the first version

which will refer the reader with specific concerns back to specific parts of the second presentation. The goal is thus to give the reader a workable knowledge in the first presentation but to overlay that knowledge in the second with a deeper level of understanding that hopefully will engender a few "Aha!"s of realization.

## Footnotes.

Although the second presentation will be footnoted conventionally, this first presentation is simply too eclectic to allow me to assign specific attributions to individual ideas. In general, though, let me give the following credits: the perceptual model of schemata roughly follows that of Christian Norberg-Schulz in his Intentions in Architecture; the notion of conceptualizing spaces for use comes from a part of an urban ecology model being developed by Stanford Anderson, and the concept of articulation springs from the felicitous phrase "an articulate environment" used in Anderson's presentation of the model in Thresholds: Working Paper 1; the characterization of two kinds of conceptual spaces is the result of a conversation with Donlyn Lyndon; and finally, although I take full responsibility for its shortcomings, the idea for the analytical method suggested itself to me while reading Peter Eisenman's 1965 doctoral dissertation.

# First Presentation

## Models are tools, not oracles.

The information derived from the application of a model can be useful, but it must be used with the constant realization that, being a construction, it has no claim to epistemological "truth." The nature of models-- their construction, their limitations, their relation to "reality"-- is discussed on pages 131-34,

As stated earlier, one of the goals of this study has been to link architectural design and analysis so that analysis would supply information directly applicable to problems of design. Now, if the two are to treat form in compatible ways, they must be based on a common model of perception. Such a model, if postulated only for its usefulness, need not explain the actual process by which the eye and brain perceive and cognize form, but need only present a reasonable scheme that accounts for the end-products of perception. In this section I will present the perceptual model on which this design/analysis method is based and show how an analogous model can account for a person's use of space. I will then show how, by linking these two models, a third schema results which gives an account of how a person might be said to cognize space for his use. The final step will then be to describe the analogous design goal--that is, to specify the attributes that would aid the viewer in seeing and using forms in the manner put forth by the cognitive model.

When a person wants to make sense of a complex visual field, he can do so by classifying it--grouping the individual objects of the field into a manageable number of sets, the set into which a given object is placed being determined by that object's conformance to an organizing schema. In personalized terms, the viewer declares certain characteristics

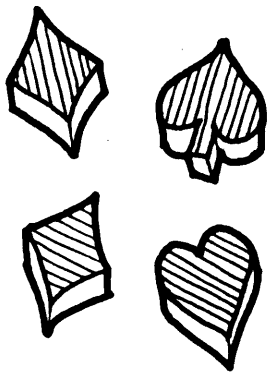

"A bunch of objects"

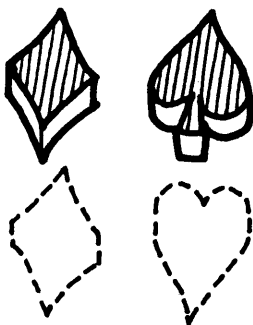

"Vertically-hatched  
objects"

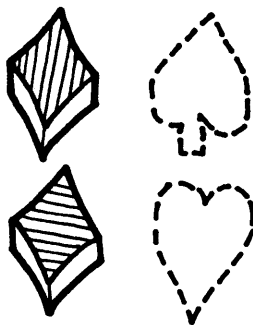

"Diamond-shaped objects"

to be significant and groups together all objects seen to possess those characteristics, ignoring other objects; he then repeats the process with different schemata, forming as many additional groups or classifications as he needs.

An ambiguously-  
classified object

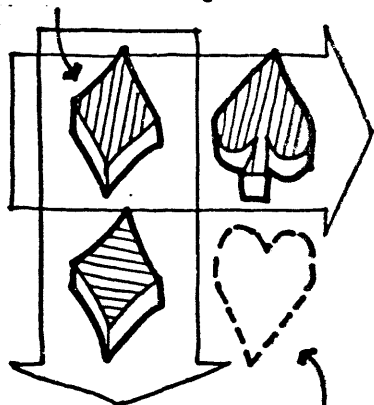

An unaccounted-for  
object

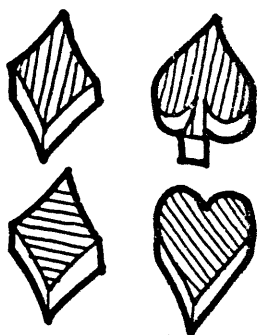

"Hatched objects"

(Note that the viewer could also have named the group "playing-card suits"--which points out that often more than one subsuming schema can be postulated, and that these schemata might represent different realms of prior knowledge, as here with the purely visual knowledge of hatching and the "learned" cultural knowledge of card suits.

In any real visual field these groupings are likely not to be mutually exclusive--that is, some objects will be seen to fit into more than one group. When this occurs, the viewer will often search for a greater commonality, a more general organizing schema consisting of a set of characteristics which all the individual members of his groups are seen to possess. By viewing the visual field with this general schema, the viewer can form a group that will encompass all the individual members of the more specific groups. Note that by doing this the viewer does not deny his initial perceptions, rather he adds to them: in effect he acquires a second layer of perception which shows him a "whole" into which all of his groups can be fit, allowing him to see the objects as simultaneously members of both the particular groups and the more general whole.



## Overlapping can be desirable.

It may be the case that such a resolving schema cannot be found, in which case, as Peter Eisenman has suggested, the realization (and acceptance) of the ambiguity produced by the overlapping visual patterns may itself be the resolution. The uses of visual ambiguity are discussed on pages 169-71.

## And for other reasons as well.

There are of course other motivations involved in the conceptualization of space, but this model will try to cover them by expanding the conventional definition of "use." I hope the reader will bear in mind that I have omitted many necessary qualifiers and cautionary notes because they would work against the brevity I seek here; and so the result is this rather "bald" presentation of ideas. I hope the reader will suspend judgement until he has read the second presentation.

Analogously, a person approaching a spatial field would organize it not so much for vision as for use: that is, he

Given a spatial field. . .

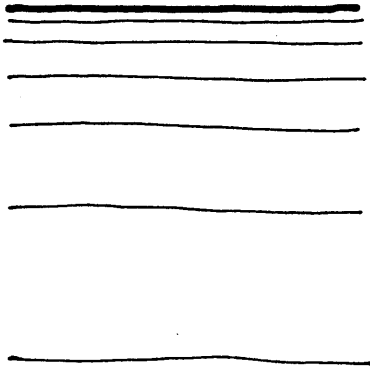

would choose out of the total field those parts-of-space which were significant for the activity he had in mind, ignoring the presence of the other parts. In the

One can imagine a well-bounded "space where I sleep;"

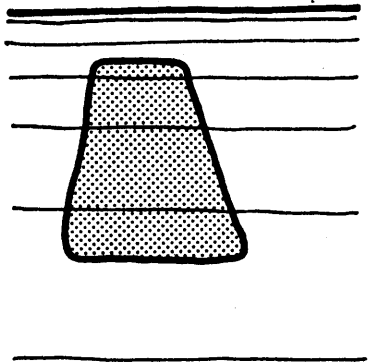

one can also imagine a less well-bounded but nevertheless defined "space where I read."

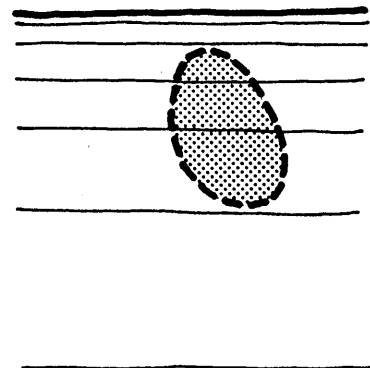

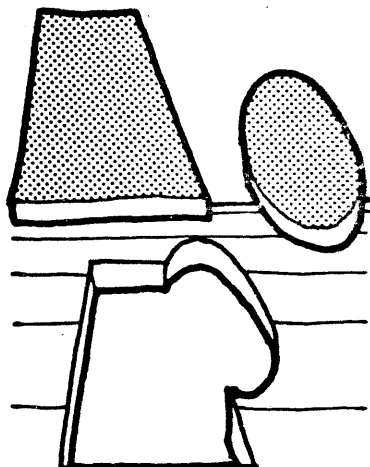

performance of his everyday activities he would choose a series of groups that would be contradictory, in the sense that they would not form a pattern like a jigsaw puzzle with fixed, identifiable boundaries to each activity-space; rather, the activity-spaces would overlap, the same portions of actual space being re-used in more than one group. But as

But note that each of these spaces is summoned into existence only when imagined: they are not conceptualized as "always present," as if each were a cubicle to which one would go when he wanted to perform the specific activity assigned to that cubicle. The user thus would not normally form (for his orientation) a "mental map" of the imagined spaces, for this would involve having to imagine as existing simultaneously all those spaces that "exist" only at separate moments in time. The problem of "jigsaw fit" thus arises only in the artificial situations, such as program analysis, when one does try to map time-bound activities into the single space of a diagram: then overlaps do occur, becoming contradictory.

These contradictions-for-the-analyst can be resolved in a way that is still true to the experience of the user by a diagram such as this:

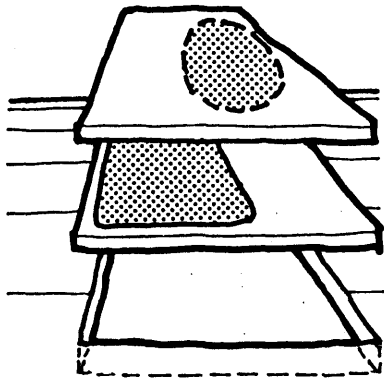

The viewer might say:  
 "At times the space where I read exists in my bedroom, and at other times the space where I sleep exists in my bedroom."

"The bedroom" thus is the encompassing schema: it is the name given to the set of significant characteristics which all the individual imagined spaces share. And in this way the two spaces that "exist" apart in time can be related to each other by the fact that both have their "existence" within the same space-- and what is more, a space that "is present" even when the two imagined spaces are not.

in the visual groups, the contradictions inherent in the organization of these spatial groupings can be subsumed by a more general organizing schema. In this case, when one apprehended the general schema, he would be able to imagine a 'larger, encompassing space "layered over" the groupings of everyday perception, a container into which all the groupings could be fit. This second level of perception would reveal to the viewer how the individual parts of the spatial field could be seen as simultaneously related to each other on the basis of activities and related to the whole on the basis of the more general schema.

## History, too, can be a matter of choice.

This notion of a person freely choosing spaces for use is derived from a model of an urban ecology developed by Stanford Anderson. But equally interesting are its implications for integrating history into design. Both of these topics are discussed on pages 152-64.

## A new idea with old roots.

This vision of design thus runs directly counter to the "close-fit" functionalism of, say, Christopher Alexander. And in doing so, it shares certain ideas with the design goals of Louis Kahn and the older Beaux Arts tradition. See pages 165-69.

From this model flow two linked notions with implications for the manner in which one would design, the first being the concept of an enactive use of space: If one assumes that the space-user will choose for himself the parts of the environment he needs to carry on his activities, then the designer is freed from the necessity of predicting the user's behavior at each moment and trying to match each behavior with a discrete single-use form. Instead the

## Other ways to make spaces.

By this I do not mean to imply that the possible conceptual spaces are limited to those that can be formed with the parts provided: people will, on occasion, form spaces quite apart from the environment. (Think, for example, of the "bubble of space" two people deep in conversation form around themselves.) I merely wish to emphasize that, by supplying a multiplicity of parts that are (as far as possible) not tied to specific uses, the designer expands the possibilities for conceptualizing spaces that do attend to environmental attributes.

designer need only provide a sufficient number of appropriate parts which the user will successively regroup as he sees fit. But recall that these successive groupings will not make "jigsaw puzzle" sense: that is, if one were to map the actual spaces traced by each of one's conceptualizations-of-space for a sequence of activities, the result would not be a floor-plan-like diagram of discrete spaces classified by use; the import here for the designer is that the space-pattern produced by activities does not, by itself, yield a clear, memorable diagram by which the viewer could orient himself in the building. The designer therefore must be certain that an alternate conceptual framework exists: he must insure that, from the forms he manifests, the viewer will be able to conceptualize a more general organizing schema that will contain and reconcile the overlapping individual activity-spaces. The designer is thus faced with the problem of presenting a multiplicity of individual parts in such a way that the user will be able to apprehend their underlying pattern even while rearranging them to suit his needs. My contention

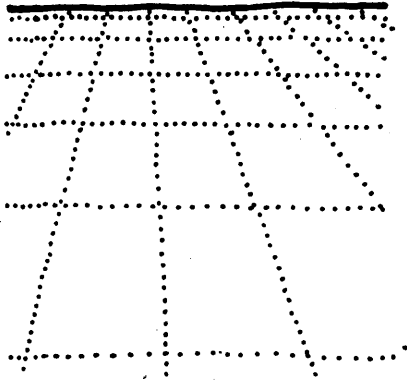

Given an environment articulated in a pattern like this, one could conceptualize two types of spaces. . . .

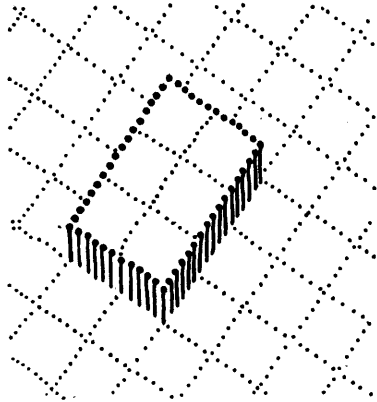

The conceptualization here "notices" the edges of the imagined space; one could thus locate the space within the pattern by reference to the position of its edges within the pattern.

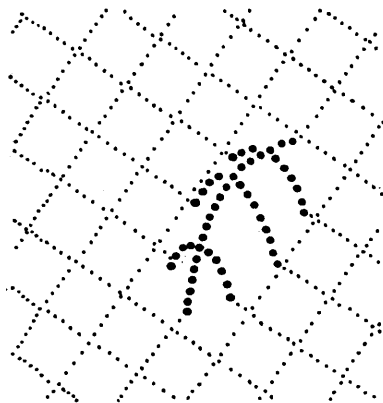

This type of conceptualization attends to a "vital center," ignoring, for the time, the

here is that this simultaneous dual relationship is best achieved in an environment of patterned articulations: that is, a spatial field that displays a comprehensible pattern of delineations such that, by exercising the option to "ignore" a delineation or to "invoke" it (as either a borderline around a space or a subdividing line within a space), a viewer could conceptualize any grouping of parts he needed for an activity. With such an arrangement, even though the articulated parts could be freely conceptualized into any arrangement that suited the viewer's purposes, their actual objective disposition would still reveal a complete and consistent pattern of organization.

pattern of articulations. Thus by being optional the pattern does not limit or inhibit this type of space-imagining, but at the same time, by virtue of their having a perceptible pattern, those articulations falling within the imagined space allow one always to be able to locate that space by reference to its position in the pattern.

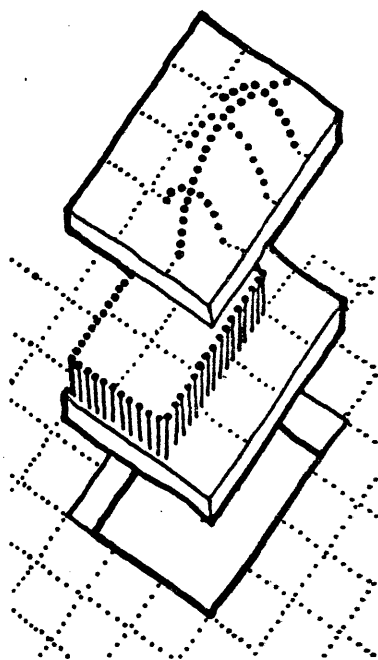

This "larger" space might be the product of viewing the spatial field "objectively," that is, detaching one's self from the activities that go on there and attending to spatial cues as no more than guides to an understanding of the space. The frequent result of this detached viewing is that one notices parts of the environment not recognized in daily activities. The ensuing "encompassing" space



thus includes all of the everyday spaces and "more."

(This "more" represents portions of space with potential for other uses, a notion discussed in more detail on pages 50-60.

## Just what is an "articulation"?

As applied to the real environment, by an "articulation" I mean any visible break in the continuity of space or surface. With this term I wish to cover breaks as solid as a wall, as unobtrusive as the edge of a rug, or as ephemeral as a change in illumination--in short, any visual cue that might be used to mark the limit of an imagined space. I want to use this single term because (in the "bald" sense of this brief presentation) all of these articulations are potentially equal. That is, given the right mental frame, any of them could be "ignored" and the zones they delineate melded together. As an example of this, consider the situation of a party in a home: depending mostly upon the focus of one's conversation, it is possible to conceptualize as a single zone the intimate space

of a couch or the larger spaces of a portion or all of the dining-room table; if one is left out of the dinner-talk, one might well become uncomfortably aware of the extent of the dining room itself; if the party were then to spread throughout the public rooms of the house, one might imagine that zone as a single space, ignoring, for the time, the walls that intervened.

## A source-book for composition.

An "archive" of compositional devices might, in fact, serve the designer as a compendium of possible solutions. But such an approach raises the possibility that the resulting buildings would be mere pastiches of historical fragments. A discussion of how this danger can be avoided--how, in fact, an archive could serve the designer as a source of meaningful innovation and historical continuity--can be found on pages 152-55,

Now whether the viewer would be able to perceive the pattern embodied in the building would depend upon the clarity of the relations between the articulated parts. The process by which this relation is manifested has traditionally been called composition, a term often denigrated as pertaining only to visual matters. But seen in this new light, composition becomes the designer's way of dealing with matters of function. For when designing for an enactive viewer, the designer's primary job becomes one of finding those compositional devices that will impel the viewer to perceive the multiplicity of articulations from which he will choose those that satisfy his own functional needs. In

## The object or the experience?

Should the artist focus his attention on the viewer's experience of his work or on the work alone, irrespective of any experience? This is a major issue in Modern Modernist art theory, and its implications for an architecture that aims to have "significance for ordinary people" are discussed on pages 176-82.

essence, the object of design under this model is to organize the forms of a building in such a way that (if one's hypotheses about perception are correct) the disposition of the forms will engender a structured pattern of perceptual effects.

Now, if design is to impel the viewer to experience a pattern of perceptual effects, then the complimentary job of analysis would be to explain to the viewer why that pattern is the way it is. This section will present an abridged explanation of the workings of the analysis half of the model. I will present this explanation by outlining the logic of the model's structure; by using this mode of presentation I hope to keep constantly before the reader the realization that the model is a constructed system (with thereby delimited applicability and no claims to epistemological "truth") and that its structure is a direct function of the purpose it is meant to serve.

The first section showed how a person could be said to perceive a static visual field by viewing it with a schema of recognized characteristics. Expanding this notion to cover the perception of a visual environment that changes as one experiences it, one can say that a viewer learns about his environment by noting the manner in which "what is presented to the eye" conforms to or departs from a similar schema. That

is, when one perceives a deviation from a set of characteristics, in effect one notices a previously-unseen characteristic (and thus a piece of new knowledge about the visible building) which one can then incorporate into his schema. This process would represent "learning something about the building," a process that would be continuously repeated in one's experience of a building. Thus it can be said that one learns about a building through an iterative process in which one modifies his understanding to reflect seen deviations from that understanding--in other words, modifying his schemata to bring them into conformance with recognized new characteristics.

But as with the classifying process of visual schemata, this process does not by itself lead to a single schema that could encompass all possible characteristics; instead the viewer can be said to adopt a repertoire of schemata which, if taken together, would be contradictory, but which the viewer holds apart by using only one-at-a-time, according to the activity he has in mind.

So if the analytical model is to serve as a tool for understanding, what it must do is to reconstruct the complex iteration by which one gains knowledge of a building into an easily-understood sequence; and further--just as the iteration proceeds until all the building's characteristics have been filed in a myriad of contradictory schemata, so the reconstructed

## Schemata as models.

Recall that I am describing a vastly simplified model of cognition here: the description of schemata as if they were "real things" is only a consequence of this manner of presentation. If schemata actually did exist, then certainly they would not behave in the strictly-separated manner described here, but would interact and inflect one another in complex ways.

sequence must proceed until it has filed those characteristics, but in a small number of complimentary, understandable schemata. To provide this accounting, the constructed sequence is made visible: it is presented as a process in which a postulated base form is subjected to a sequence of distortions and modifications until its form matches that of the actual building. This process of modifying a developing base can be said to account for the process of modifying schemata in that, just as one modifies a schema to reflect characteristics not recognized before, so the base form is distorted from its previous state to acquire characteristics it did not possess before.

But there is another level of "learning about a building" which must be modeled. When a viewer apprehends a previously-unseen characteristic of a building, he might view it simply as a fortuitous visual occurrence, to be noted and schematized but not otherwise considered; or he might feel that the characteristic is such that its occurrence needs to be "explained;" and unless it appears completely capricious, the viewer will likely interpret the characteristic as being a reflection of one or more of the factors that he assumes influence the visible form of the building. These explanations, like the schemata they interpret, would be constructed piecemeal by the viewer and thus, like the schemata, would not

## What about "incorrect" interpretations?

The second presentation attempts to deal with the issue of building interpretation by presenting a case for considering buildings as artifacts that are reinterpreted over time. For a discussion of this approach and how it avoids complete relativism, see 155-64.

lead to a single coherent interpretation. The model therefore must account for the viewer's explanation of a building by constructing an alternate interpretation that will provide a coherent understanding--one that will subsume the viewer's partial explanations in the "Aha!" manner described above. To do this the model takes the many competing aspects that a thoughtful viewer might cite as reasons for a building "being that way" and reconstructs them into a simplified system of four interacting factors (whose operations will be clarified by their use in the analysis which follows this section):

1. BUILDING PROGRAM: as a rationalized accounting and not a simple retelling of the program, this construction is intended to be a subsuming resolution of all the activities that could reasonably take place in the building;
2. The MOVEMENT of people to and through the building--seen not as a tracing of the actual paths taken between walls or along walkways, but as a resolved vector of the totality of movement;
3. SITE INFLUENCES: as with the program, this is not a summing of the specific ways site conditions impinge on the building, but a resolution of those conditions into a single conception;
4. FORMAL PREDISPOSITION is a construction that is intended to model a reasonable viewer's expectations about

how building forms will look--or in extra-personal terms, to account for the influence that a lifelong experience of buildings has on subsequent perceptions of buildings.

To summarize then: the analysis will take the complex process of acquiring knowledge of a building, reconstruct that process into an understandable sequence of operations, and present that sequence as a "story" in which a base form undergoes a series of distortions until its form matches that of the actual building. Since each of these distortions will be constructed so as to be both a representation of a perceptual effect that one might reasonably experience and an acknowledgement of one or more of the aspects that the building might be seen to address, the developing sequence of distortions will provide two accounts:

## Models and matching.

Thus the model itself has aspects of a selective schema in that it might tend to "recognize" only those formal arrangements that it could "explain" as reflections of its four factors.

But this is one of the crucial junctures where a model is tested against the "reality" it purports to cover: for since a model is constructed only for the purpose of accounting for a body of data, any account postulated under the framework of the model has no existence prior to that of the data-base: the account therefore cannot claim that unexplained data are "anomalies;" in such a case the account is anomalous and must be changed until it conforms to the data.

## A significance for architecture.

If "significant form" is the ultimate goal of this study, then this integration-of-perception might well be that significance. For a discussion of this possibility and the esthetic theory upon which it is based see pages 187-91.

## What is architectural perception?

Or is there something about architectural form that sets it apart from ordinary form? The second presentation focuses on these questions and, in so doing, tries to show how architecture's deliberateness is the source of its uniqueness and autonomy. See pages 124-29.

as a sequence of acknowledgements-of-aspects, the "story" will show how these aspects could be reconciled and how that resolution could be made manifest through a pattern of perceptual effects; or conversely, as a sequence of representations-of-perceptions, the "story" will show how one's perceptions could be integrated into a rational pattern--that is, a pattern that "has a reason for being that way" by virtue of its being interpretable as a reflection of a (like-wise rational) resolution of the forces that brought the building itself into being.

These two interpretations of the "story" show how the model serves as a common base for both design and analysis. The first interpretation states the goal of design under this model--that is, to present to the viewer a pattern of perceptual effects that signifies the designer's resolution of the many aspects of the building problem, but which (by being a visual and not a spatial pattern) does not bind the viewer to that single vision. The second interpretation describes the aim of building analysis--to reveal how a building, seen as architecture, can integrate confused experience: in a real sense, to answer the question "Why architecture?"

The test of any model is the convincingness of its account and the usefulness of its insights. The analysis to follow will be just such an account, to which



the reader can apply his own tests. The designs in the final section will then make use of the insights of the analysis.

# Analysis

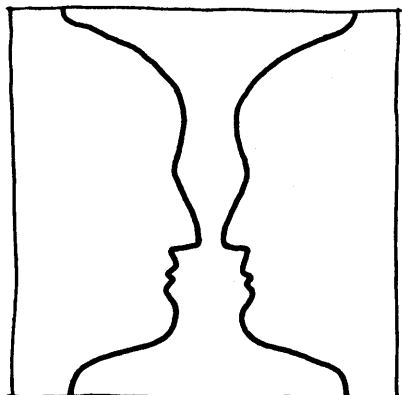

## Formal relations.

The distinction between a base form and a form that deviates from the base is a convention I have adopted for this analysis. Actually, of course, each form can be perceived as either a base or a deviation, depending upon the schema of expectations with which

One of the notes in the first presentation pointed out that, with certain ensembles of forms, a viewer might be able to see more than one perceptual effect, and that the realization of this ambiguity might itself be the subsuming knowledge that made sense of a visual or spatial field. One can see that this type of ambiguity is possible because of the nature of the type of perceptual effects with which this study has been dealing; that is, when one apprehends the perceptual effect I have called deviation, in effect one is postulating a certain set of conditions and noting departures from it. But with an ambiguous field, the same viewer could reasonably postulate an alternative set of base conditions, in which case he would perceive another set of deviations. This situation is analogous to the famous vase-and-profiles drawing in which either form can be seen as a figure or a ground--as a base form or a deviation.

In the case of an analysis of this kind of ambiguous situation, one is not dealing with a situation in which one set of base conditions holds true all through an experience of a building, but instead one deals with a situation in which he must be able to imagine several sets of base conditions simultaneously and note the deviations which, during his experience, occur from each. In an actual experience, this juggling of one's assumptions can lead to real pleasure, and a modelling of this

one views the ensemble. What one is really dealing with in a situation like this is not forms themselves but the relations between forms.

In fact, isolating this relation is the real object of the analysis, for in designing a new building consonant with the old, the designer would try to manifest this same relation, but between new forms. How this might be achieved is demonstrated in the design sections.

juggling--a "story" in which several different base forms undergo parallel sequences of different distortions-- can be particularly revealing. But putting either of these processes into the necessarily uni-linear medium of words is especially difficult. Therefore I ask the reader to follow the discussion with the willingness to carry along two or three threads of thought at the same time; so when the text picks up and develops one of them, hold the other threads in abeyance--they will be dealt with in time.

One last difficulty: the object of this analysis no longer exists in the form in which it was built; the house has been extensively modified, and its open site encroached upon on three sides. I have visited the building and enough remains of the original conditions that-- with the aid of the working drawings-- I can reasonably reconstruct an experience of the building-as-built.

## Browne or Brown?

There is some confusion over how the Reverend spelled his name: Mrs. Van Rensselaer uses "Browne;" Hitchcock prefers "Brown;" Richardson's drawings use both. If the question had truly mattered for the analysis I would have checked the town records. But as it is, I am using "Browne" because, when I visited Marion, I found a Browne's Pharmacy in the village center.

The house was designed by H. H. Richardson for Rev. Percy Browne in 1881 and built the following year in Marion, Massachusetts, a hamlet about ten miles east of New Bedford on Sippican Harbor, an inlet of Buzzards Bay. Its site, at the time of construction, was on the edge of an open hillside north of the village, with a clear view to the ocean. The house fronted on the road that led from the railroad station to the village,

and was approached via a drive that curved up from the bottom of the hill. Since the house was built to be a weekend and vacation retreat for the Rev. Browne, the program includes, in addition to the usual family and servant accommodations of the time, a pastor's study in which he could both work and receive people seeking counsel.

Almost from the beginning its qualities were appreciated. Mariana Van Rensselaer, writing in 1888, particularly liked the house and, in fact, chose it to the exclusion of the presently more famous Stoughton house in Cambridge, which it antedates by a year. Giving a hint of the flavor of an experience of the original house, she wrote:

A country house for the Rev. Percy Browne at Marion, Mass., was designed in the last months of the same year. It is one of the smallest structures that Richardson ever built, and, I believe, the least expensive; yet in its way it is a great success. It stands on the crest of a short but steep slope overlooking a road in the outskirts of the village, beyond which lie flat meadows and the not distant sea. It is very low and comparatively very long, with many windows in broad groups, a loggia in the centre of the front, a piazza at one end and across a portion of the back, small dormers, and low but massive chimneys. Its foundations follow with delightful frankness the variations of the ground upon which it stands, while its good proportions and the harmonious arrangement of its rooflines give it that truly architectural character in



REAR OF PERCY BROWNE'S HOUSE, MARION.

which dignity may lie for the most modest building. It is so appropriate to its surroundings that it seems to have grown out of them by some process of nature, and it is equally appropriate to its purpose. It explains itself at once as a gentleman's summer home, but with a simplicity which does not put the humblest village neighbor out of countenance. Inside, the planning gives an unexpected amount of comfort and air of space. The doorways are very wide, and are so arranged as to afford a diagonal instead of a straight perspective. The windows are carefully placed to command every possible point of outlook, the rear views toward woods and sunset being as much considered as those which show the sea. The longer one studies this house the better one likes it, the more typical it seems of that sort of excellence which the American owner so often craves--artistic treatment combined with cheapness, comfort with small dimensions, beauty with simplicity, refinement without decoration. Outside, the only touch of ornament is given by the varied shaping of the shingles, and inside, pleasant tints alone relieve the plainness of the woodwork, and good outlines the severity of the chimney-pieces. It has sometimes been said that Richardson took so much interest in great problems that he had none left to give to small ones. But no one could have more carefully studied a little house like this, the cost of which, exclusive of foundations, barely exceeded twenty-five hundred dollars.<sup>1</sup>

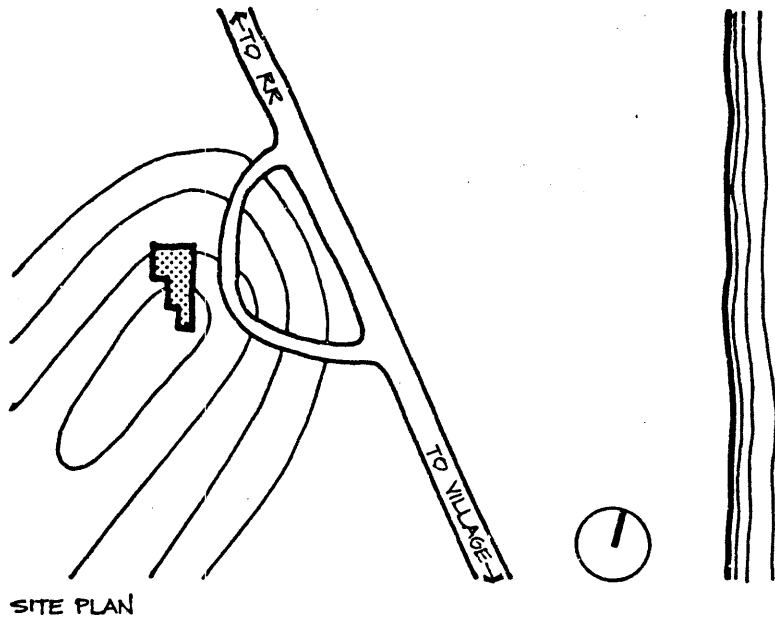

SITE PLAN

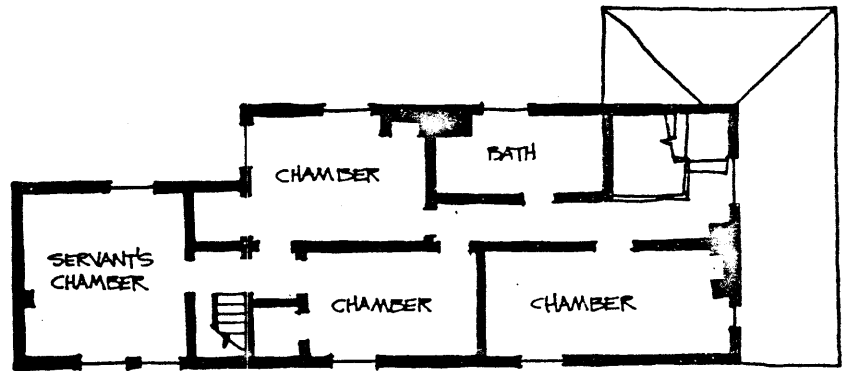

SECOND FLOOR

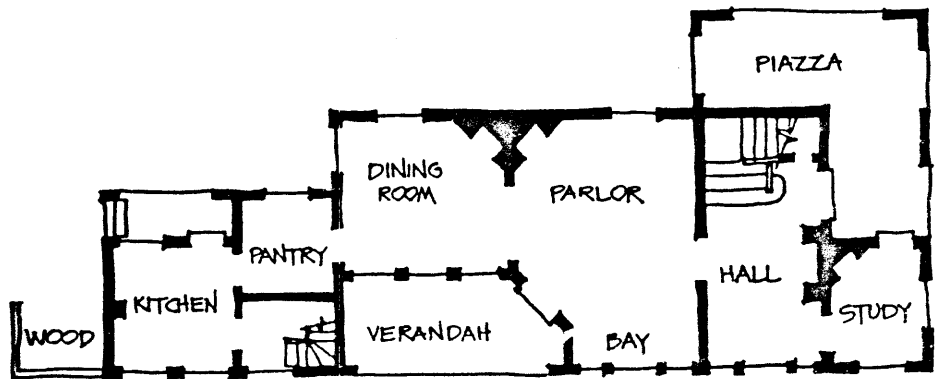

FIRST FLOOR

Looking at the total form of the house, one can postulate a base form which embodies a resolution of the program: an ensemble of three houses--a gambrel-roofed barn to house the service wing, a hip-roofed cottage to serve the pastor, and a square gabled main house for the shared activities of the family. As specific, familiar forms, these three houses can serve as a base on which the postulated sequence of distortions can be applied, but as a model for the experience of the space they contain, they are incomplete. One of the illustrations of the first presentation noted that there are two ways one might be said to conceptualize space: one way attends to the specific boundaries of a space, seeing space as if a vacuum inside an empty box--the type of conception modeled by the three specific, hard-edged house-forms; but the other type of conceptualization focuses inward upon the space itself, viewing space as an almost palpable substance, having extent and therefore boundaries but no "hard" configuration. As this analysis proceeds, it will become apparent that, in the case of the Browne house, these two space-conceptions are in tension with each other; that is, while the specific shape of the building envelope suggests that it can be divided into three empty, hard-edged boxes, other spatial

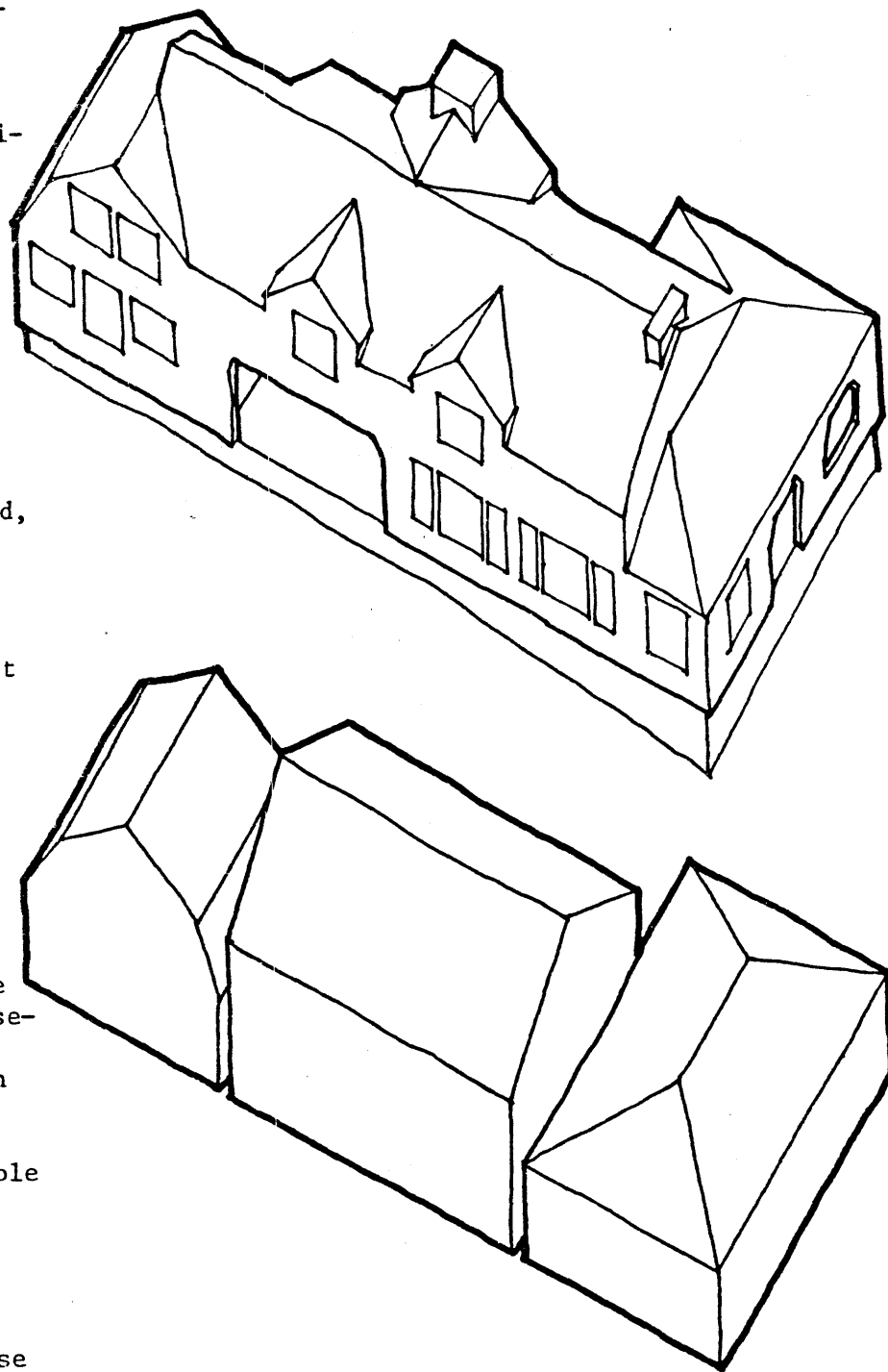

cues will be seen that just as strongly suggest alternative arrangements of the palpable spaces of the second type within the same building envelope. To distinguish these two types of space-conception, I will adopt the convention of speaking of spaces of the surface order (space as a hard-edged empty box) and spaces of the volumetric order (space as a cloudlike, full volume).

If one thus looks at the three sub-houses as spaces in the surface sense, one can visualize an arrangement of shapes that would model an analogous volumetric conceptualization of the spaces: a tall, narrow shape next to a cubical shape next to a low, long shape. Thus there can be seen two base forms which will interact in the analysis: the three houses are the base form upon which one can display distortions of the surface order, and the three shapes are the base form upon which one can display distortions of the volumetric order.

Just as the surface-order base can be analyzed as a reflection of the building program, so the volumetric base form can be seen as a reflection of the hillside site upon which the house sits: a progression from a tall compressed form, grading through a stable compact shape, to a low spreading form. But recall that an additional site condition

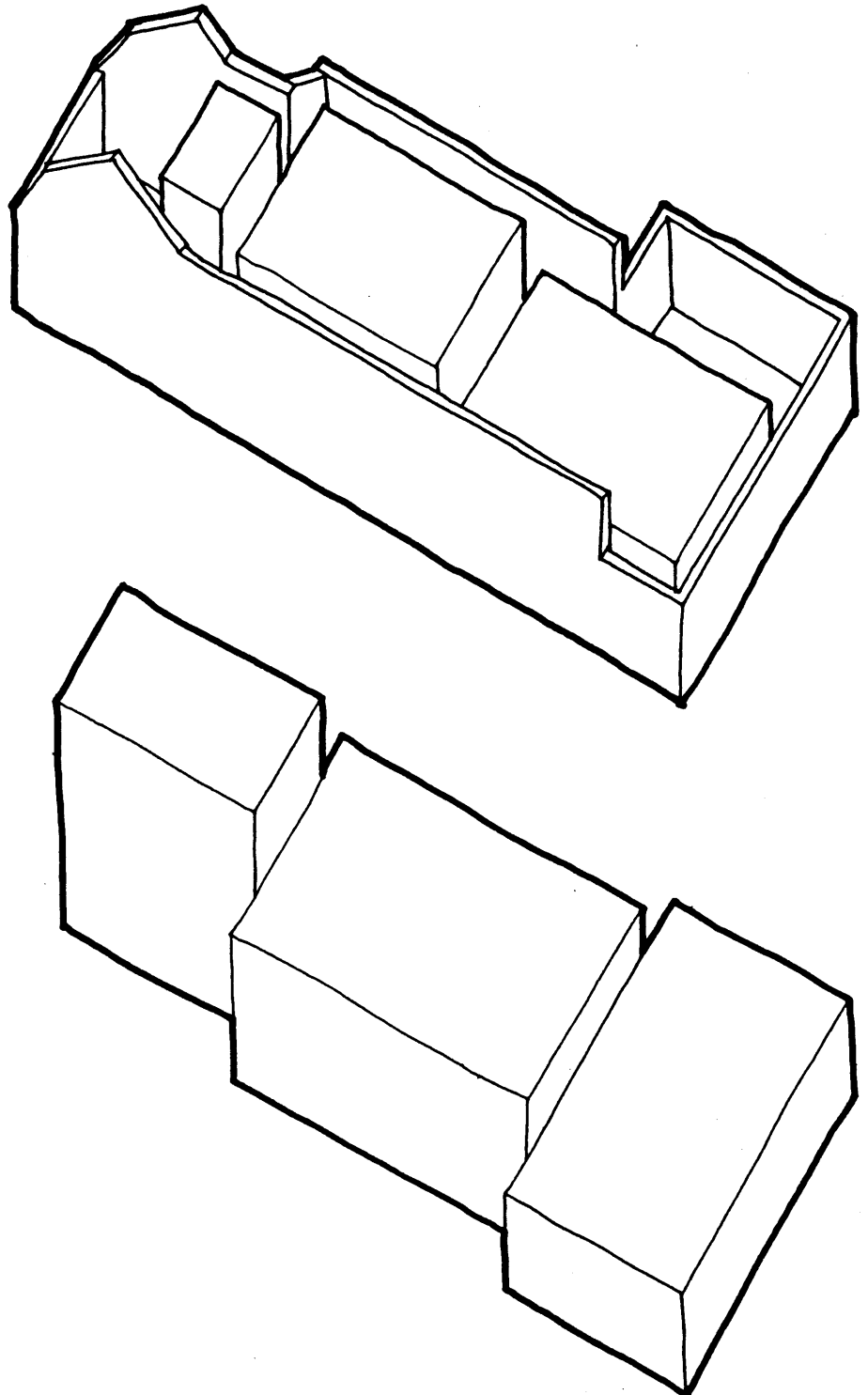



is the fact that the house sits parallel with and facing the ocean: the forms can be seen as acknowledging this condition by their being aligned along a plane that enfronts the ocean.

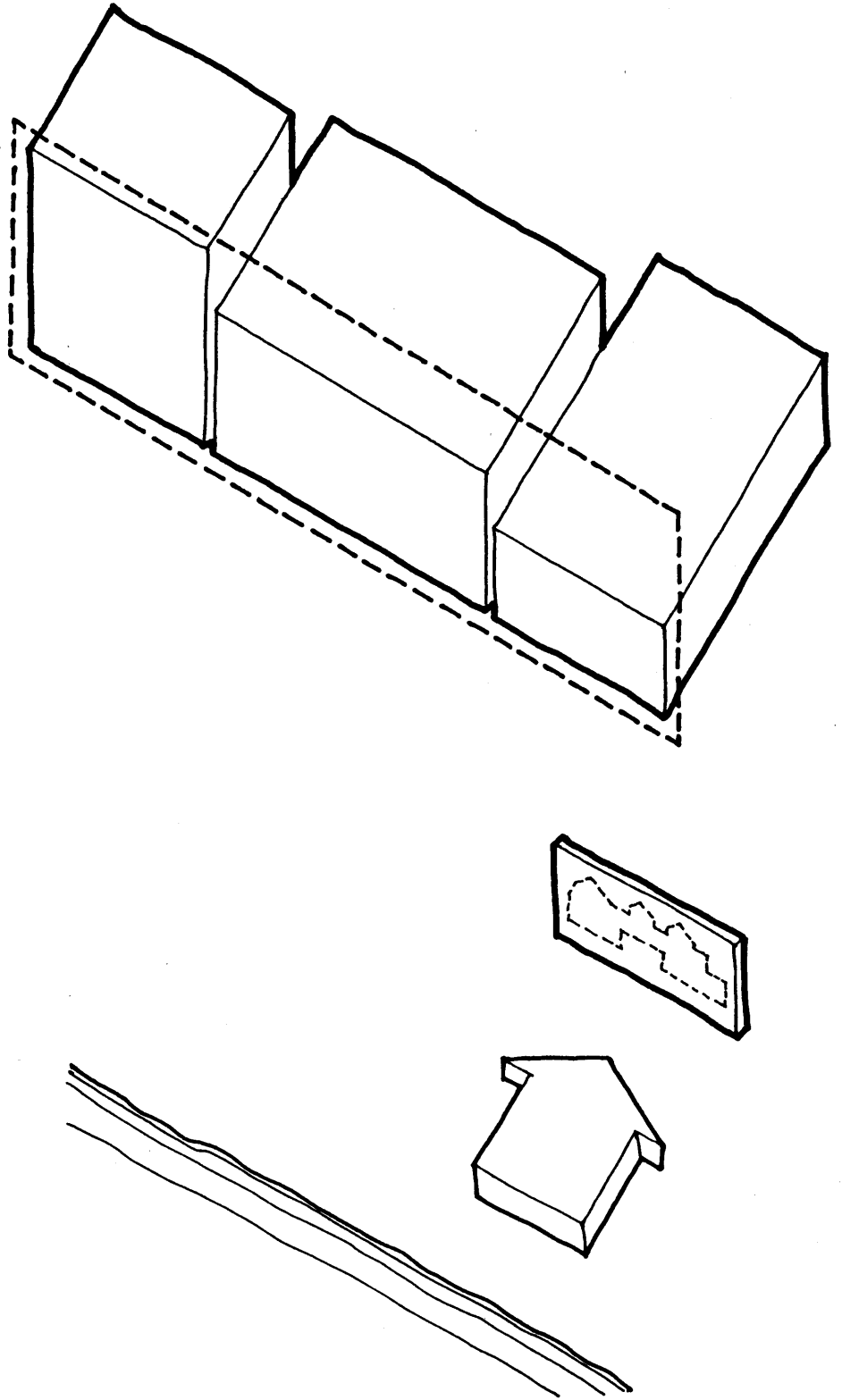

This plane, in fact, can be seen as a link between the volumetric and surface orders--as a hard edge against which the soft volumes are tensed, as if pinned against it and seen in cross-section. The analogous devices by which actual interior volumes are linked to the outside of a building are windows; and if one postulates a base arrangement of windows upon this plane and observes the distortions necessary to bring this base arrangement into conformance with the final configuration, these shifts in placement can be read as indicating shifts in the volumetric spaces behind them. These volumetric shifts can then be interpreted as acknowledgements of aspects of the building situation--interpretations which, in turn, are lent plausibility by their being indicated in ways in addition to the window shifts.

Let us postulate the illustrated pattern of windows in this base plane: one can see that each of the three groups of windows reflects both the volumetric- and the surface-order spaces behind it: the pair-over-triple arrangement of the kitchen house fits easily into the gambrel profile, the widely-spaced pair of the pastor's house reflects the spreading quality of the hip roof, and the close-spaced pair of dormers-over-triples befits the dual nature of

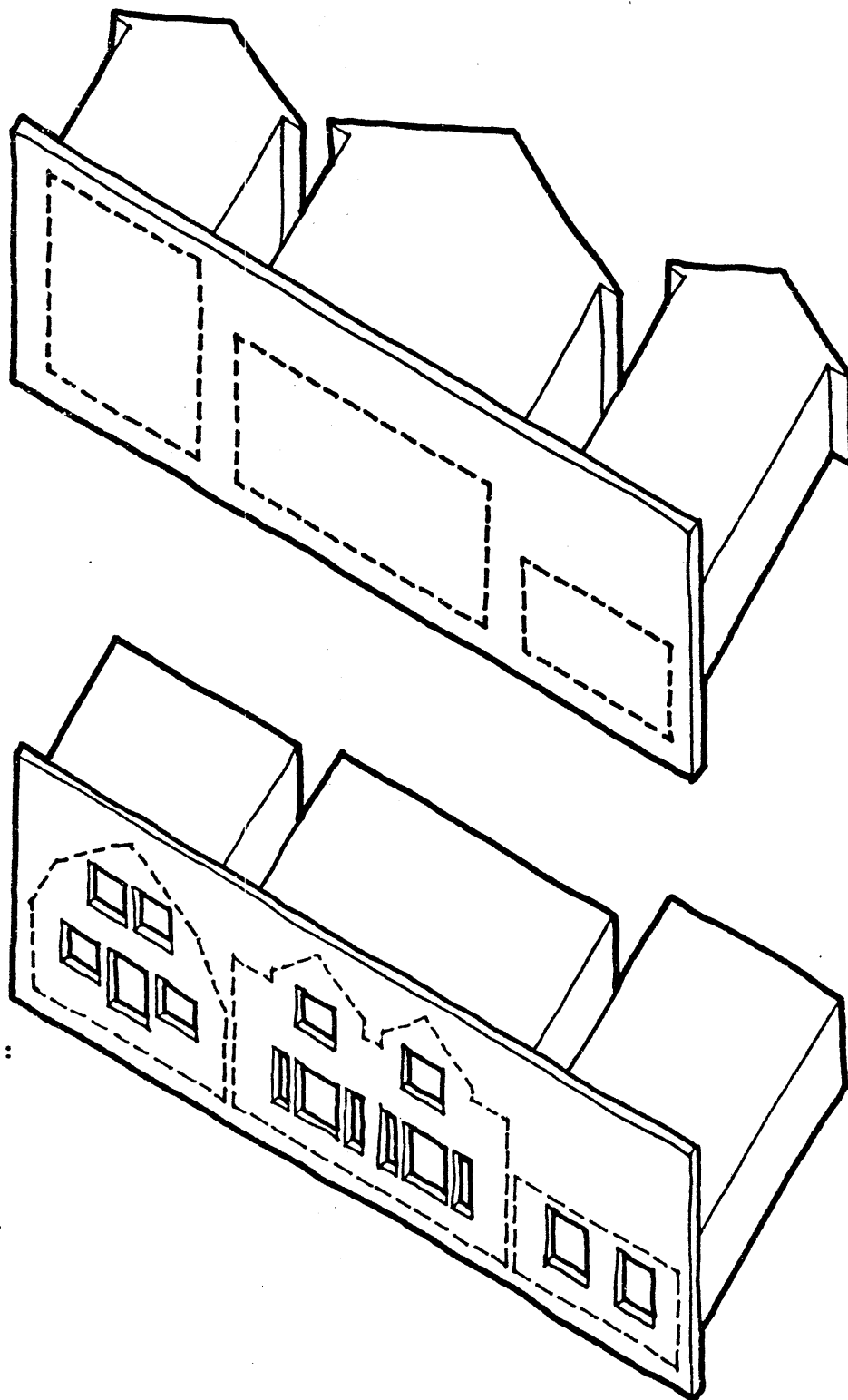

the nearly-cubical gable box that, because of its shape, seems to focus both centrally (toward the center of its facade) and laterally (along the breadth of its facade). Given this base arrangement, the sideways shifts necessary to move the windows to their final positions can be seen (on one level) as reflections of a lateral expansion of the central volume that interlocks the three volumetric shapes: the windows of the kitchen house shift left; and on the right hand, one of the dormers moves right, and the pair of triples moves so far as to push one of the pastor's windows around the corner.

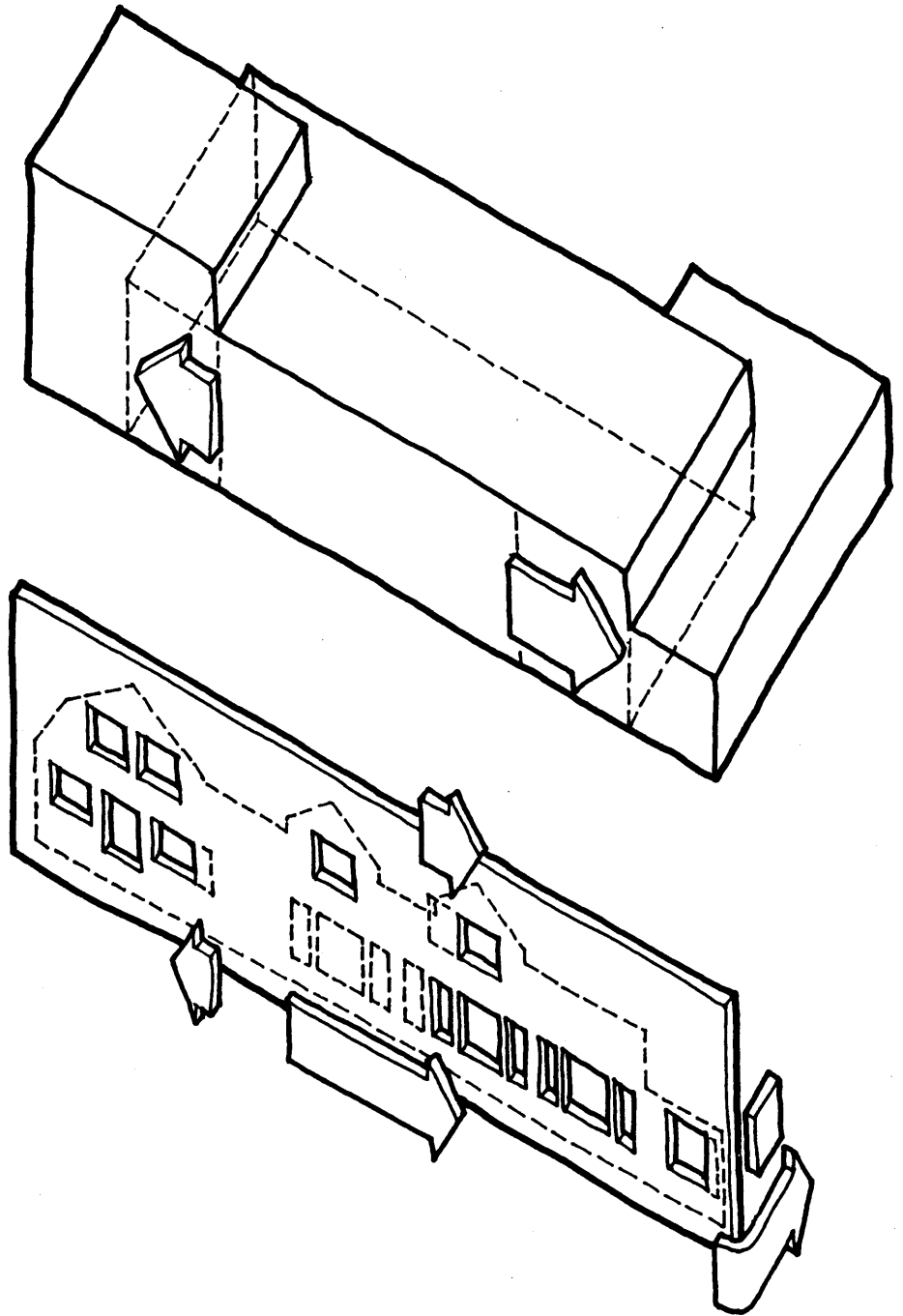

These window-shifts can be analyzed as reflections of several more conditions, but first note the consequences in the specific, surface order of this interlocking in the volumetric order: the center gable box extends and penetrates halfway into each of the houses beside it; but note that in front the center house overlaps the side-houses, while from the rear the two side-houses are seen to overlap the (extended) center form. This double reading can be analyzed as a way in which the ensemble, even though linked, remains a true embodiment of the three-part program; that is, by virtue of both overlapping and being overlapped, the ensemble is prevented from appearing as a dominant family house with two subordinate wings.

(But more crucial to an understanding of this analysis is the fact that this same ambiguous overlapping defeats any notion that the tripartite division of the base form is the only correct basis for a perception of the form of the house; in precisely this optionally-viewable sense, by being overlapped, these forms are articulated at four reasonable places.)

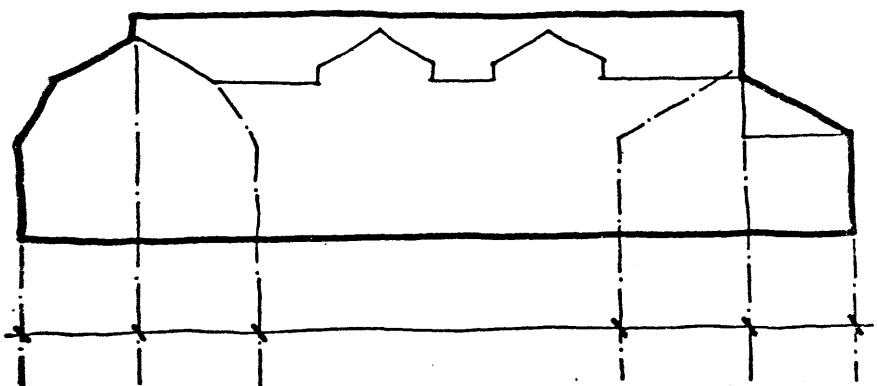
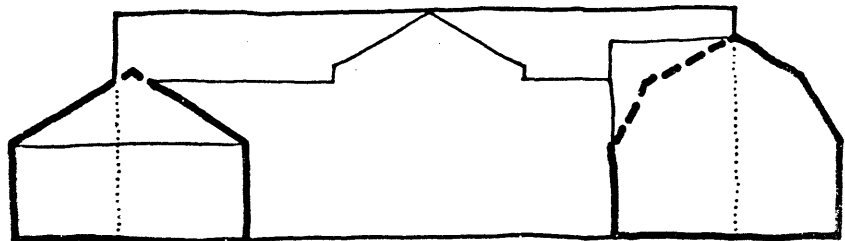
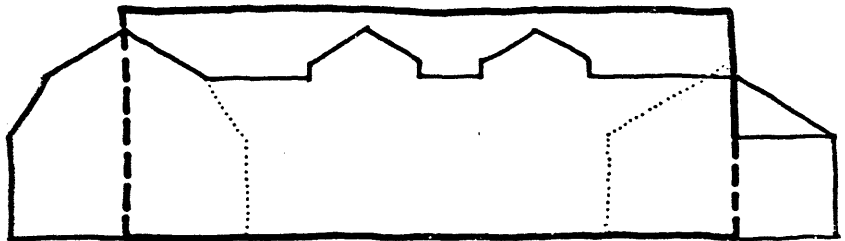

Now recall the pattern of movement of the windows: the windows of the first story moved to a much greater extent than those of the second story--giving rise to the perception that, besides being seeable as a single plane, the facade can also be viewed as articulated into three bands, each of which moves at its own rate. (This banded interpretation is given plausibility by the two flaring courses of shingles in the actual house--one above the first-floor window heads, the other at the foundation.) This extension of the first-floor band can be analyzed as an acknowledgement of three of the postulated building aspects, the first of which is formal predisposition.

Recall that one of the purposes of the model is to provide a plausible account of "why a building is that way;" with the aspect of formal predisposition, the question to be answered is why each of the three houses takes that shape and not another; that is, if one accepts each roof shape as a given, the model should provide a convincing reason for why each shape was not, say, longer or wider.

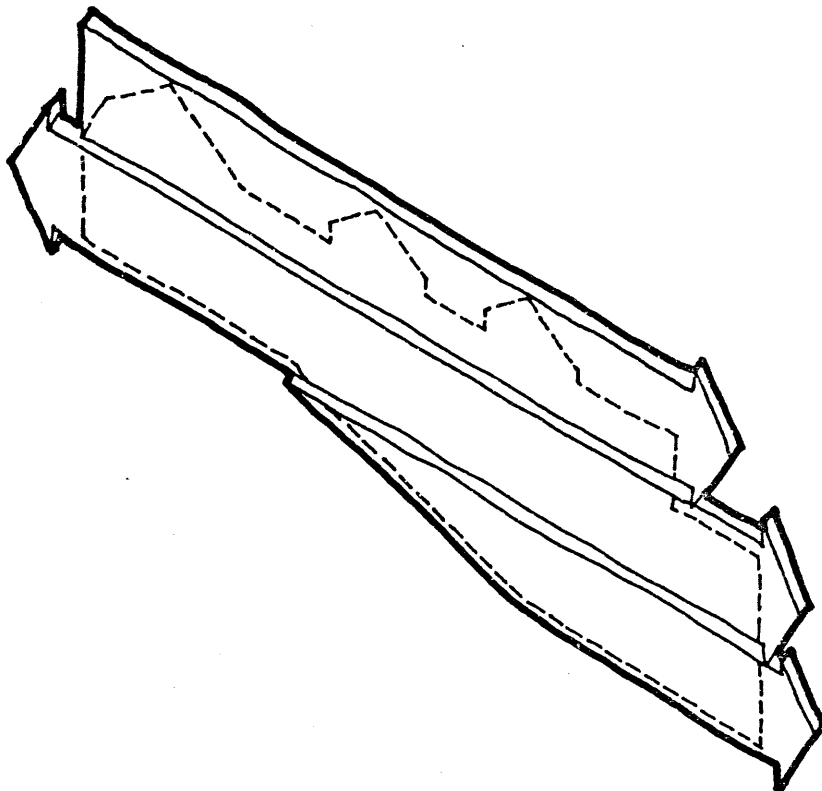

Specifically, both the gambrel-roof and gable-roof shapes could be extended in the direction of their ridge-lines and still retain the basic character of their roof shapes, and in like fashion the hip-roofed form could spread outward and still remain a hip roof. But the articulated facade can be seen as stopping or containing this potential expansion: the gambrel-roof barn can be thought of as straining against the front plane (an analysis given plausibility by the fact that a portion of the barn's rear wall leans toward the front plane); the center gable-roof box is contained by the double overlapping mentioned above; and the L-shaped extension of the first-floor band checks the spreading of the pastor's house (except at the rear where the roof has a pronounced "kick," as if ready to spread itself outward).

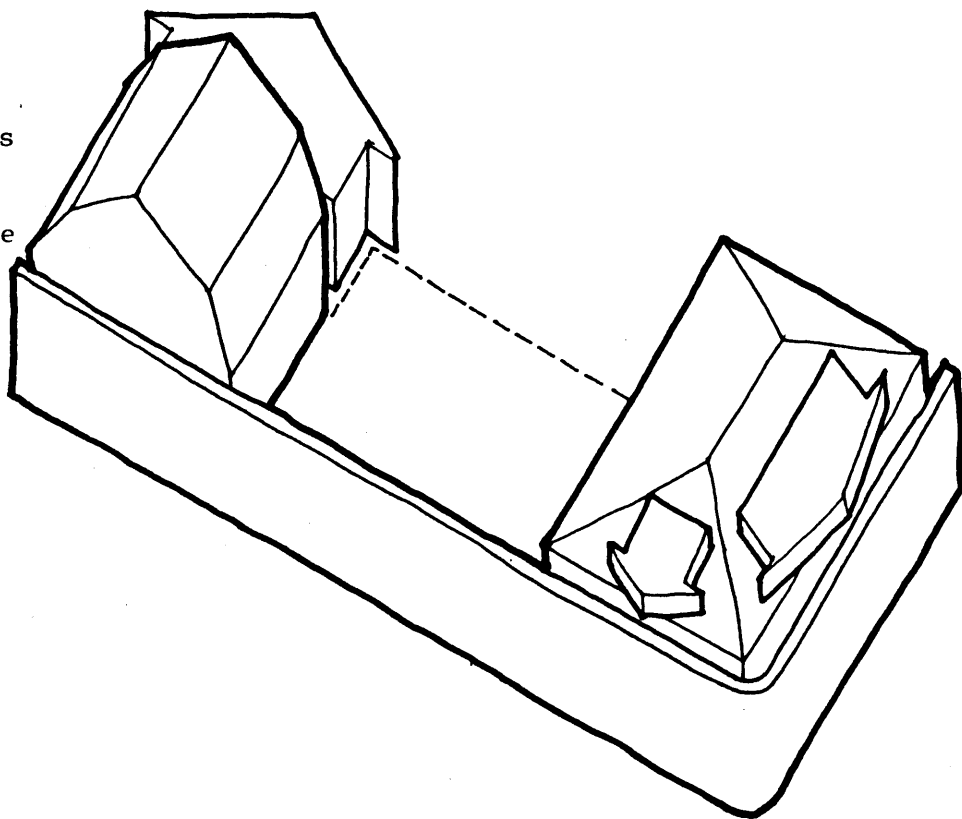
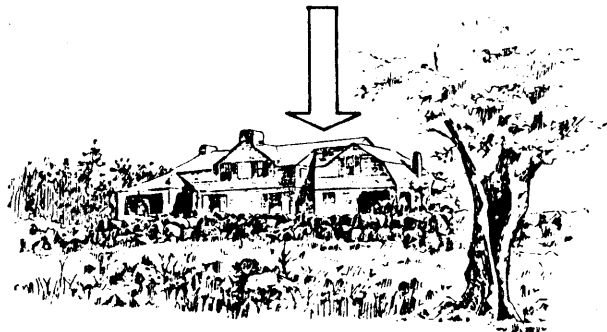

The second aspect being addressed is site conditions, in that, by extending the plane of the facade around the corner, the total ensemble can be seen to enfront both the ocean and the hillside.

Thirdly, if one focuses specifically on the first-floor band, one might say that, in stretching around the corner, the band has "snapped" at the area of the front porch (a reading made plausible by the lip that reveals the thickness of the actual facade plane). This break can be seen as an acknowledgement of movement, in that it both allows and locates entry into the house.

The movement aspect raises a number of issues, but they can be dealt with by keeping in mind the basic analytical method being employed here: that is, to postulate a reasonable expectation, to note how an observed deviation moves away from that expectation, and to analyze that movement as acknowledging one or more aspects of the building situation.

With entry, the reasonable expectation (all other things being equal) would be to enter the form at its centerline: by occurring where it does, this break in the facade locates entry at the centerline of the total facade plane and not, as one might expect, at the central axis of the volume of the center house. By this reading, one is

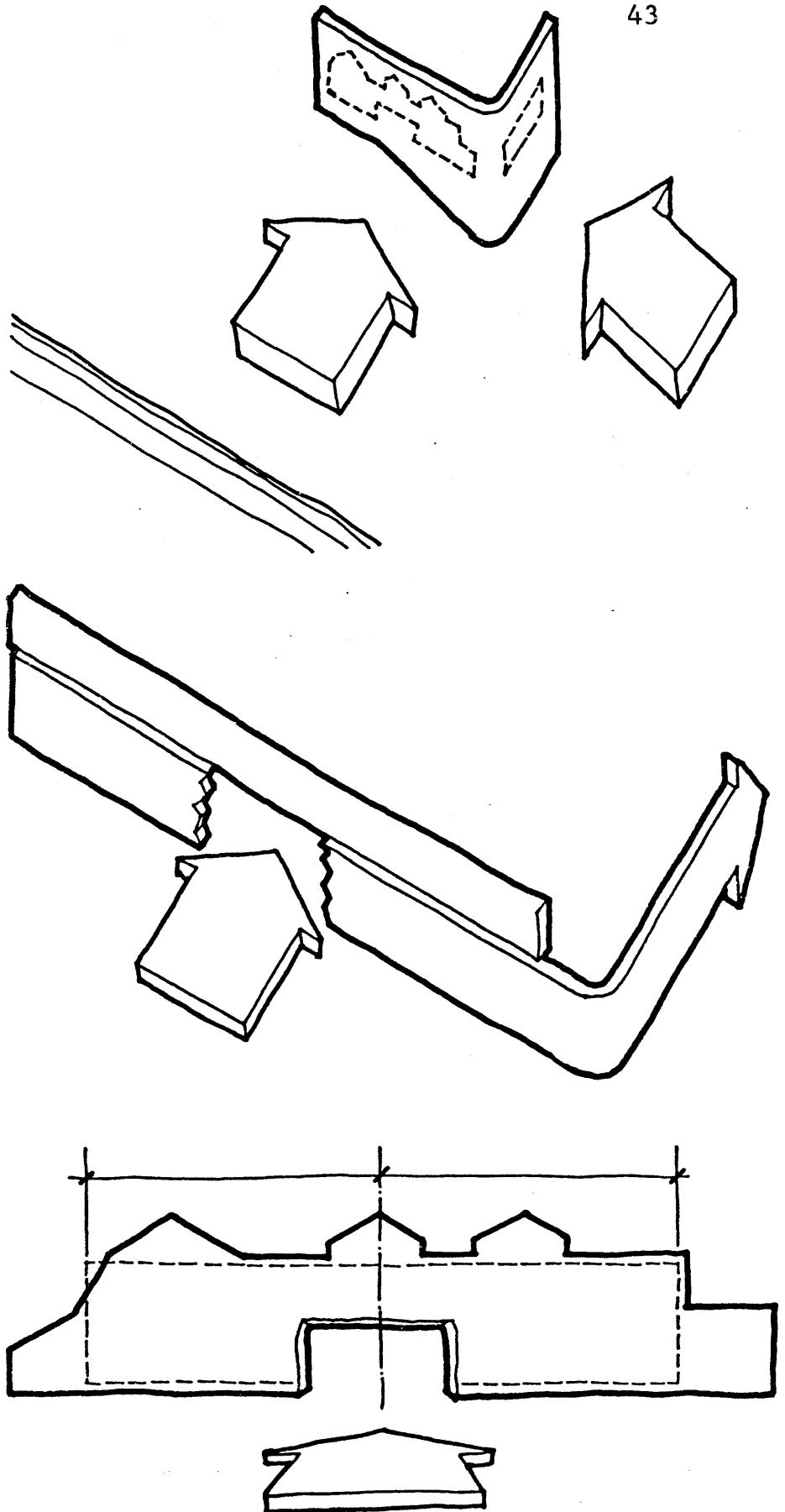

led to the postulation (which remains to be shown) that, in this house, movement is related primarily to surface; that is, acknowledgements of the requirements of movement can be found by looking for distortions of the specific spaces of the empty volumes of the surface order.

Following this reasoning, if one considers the porch as a kind of prelude to entry, then its specific shape might be seen as a distortion from the expected (base-form) shape of a vestibule. And just as the specific shape of the vestibule suggests a natural path along the axis of the two openings, so the distorted shape of the porch volume engenders its own natural path of movement, one that receives movement from any point along the broad front step and turns it toward the door along the diagonal axis.

Recalling the supposition that movement is associated with the surface order, note that the diagonal axis of the porch is parallel to the line that connects the ends of the L-shaped facade plane; one might thus say that, if the notion of penetrating the house volume reflects ("makes one aware of") the front surface, the actual act of entry, by occurring upon this diagonal, reflects the total surface (and thus the total surface-order

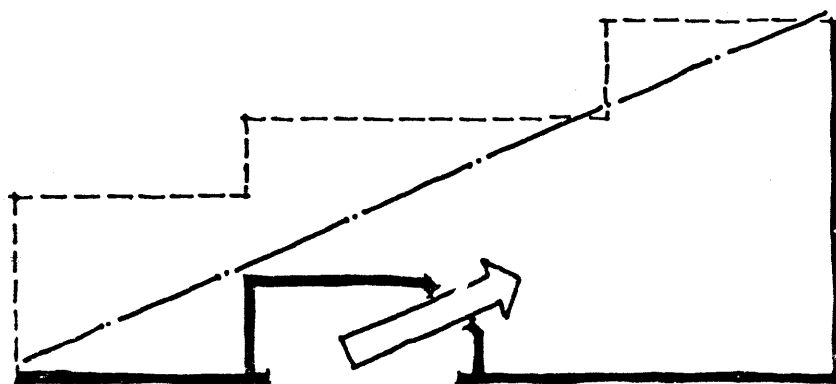
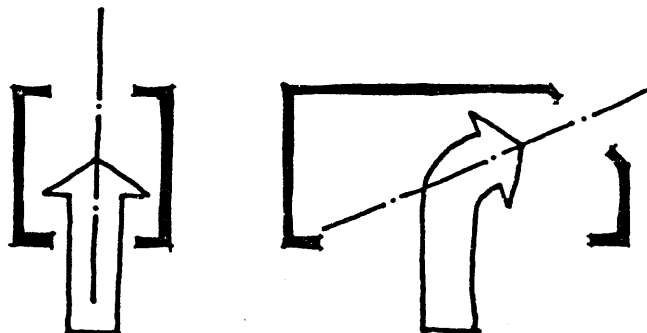



space) of the combinatory form. Again the path of movement is distorted to acknowledge an other-than-expected aspect of the building situation, the two-fronted nature of the site.

Now, once entry is accomplished, the path through the house ought to be analyzable as a reflection of the basic programmatic requirements of movement. Once again, a deviation from the normal program for a dwelling occurs in that, in addition to providing a circulation armature for the family's movements through the house, the path of movement must also provide visiting parishoners with a reasonable, natural path from the front door to the pastor's study. And once again the "naturalness" of the path is maintained by distorting the expected pattern in a

manner which reflects the unique requirements of the program.

In the normal, four-square American house, the pattern of movement one might expect to encounter upon entry would be a cross of three branches: directly ahead, on the axis of movement, the stairs; perpendicular to this axis, two opposed paths, one to the intimate family quarters, the other to the more public area for guests and family together. In the Browne house this expected pattern is maintained but doubled to reflect the dual nature of the house. This doubling of movement can be analyzed as having its source in the very same side-shift of surfaces that extended the facade plane and provided the rupture for entry: that is, the stairs (shown in the base form of a spiral cylinder) can be seen as shifted from their normal place of facing the entry axis to a new position in which they face the turned axis of entry. In this manner, the path from the front door to the stairs is stretched and the branching cross-paths are duplicated--the first set for the family (leading to the intimate, family-only dining room and the family-and-guests window seat), the second for guests (leading to the living area where close friends would be entertained and to the reception hall where the parishoners would be received by the pastor).

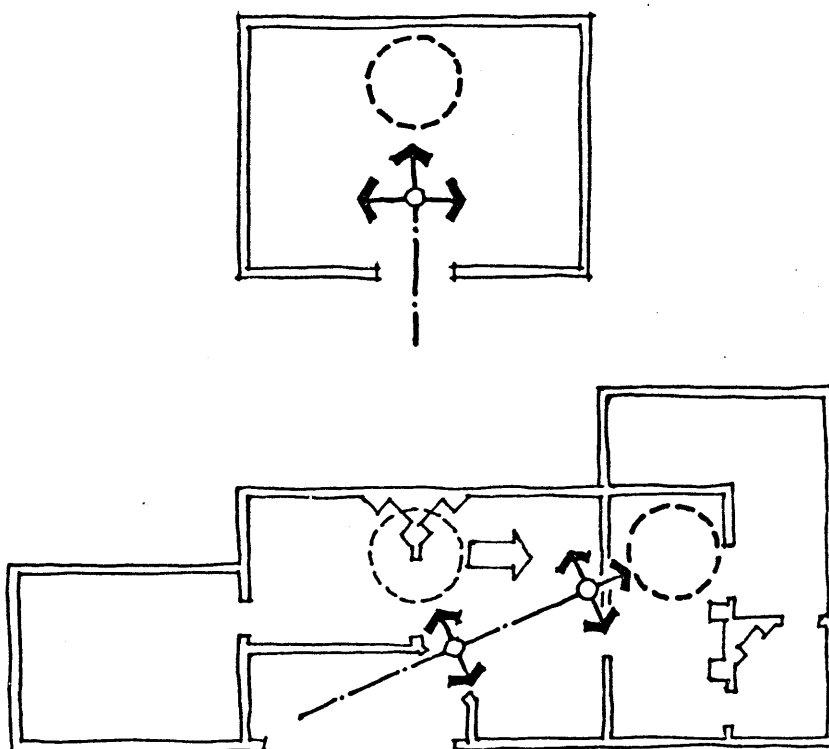

One more aspect of the stair arises in its formal predisposition: that is, if the stair is seen as shifted, what is a convincing reason for its not being shifted to a different extent? An answer can be seen if one postulates a base relation in which the stair sits astride the centerline of an entry facade. Recalling that the first-floor band was seen as ruptured at the porch, one can look at the resulting portion of that band as the facade of that part of the house involved with parishoners. The stair might thus be thought of as positioned on the diagonal axis of this bent plane; and indeed the openings in this facade are symmetrical about this diagonal axis. But an even more

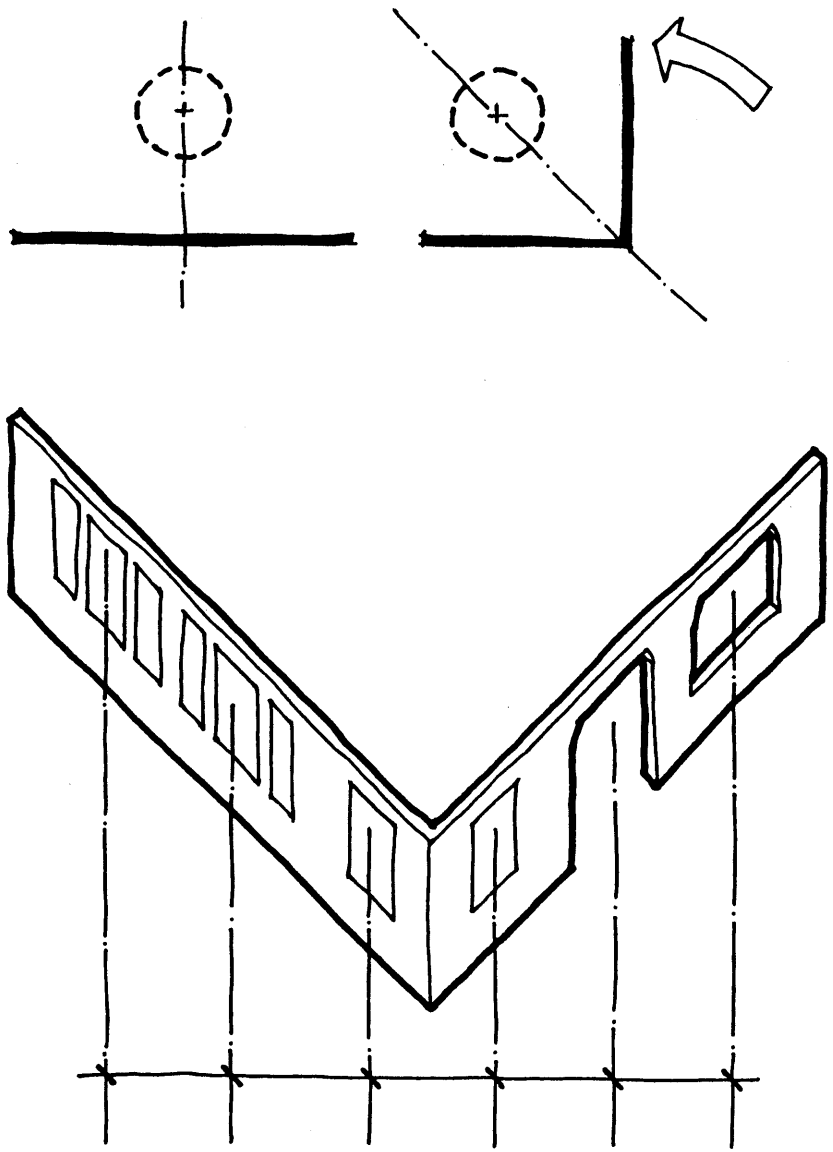

intriguing explanation results if one imagines a base form for this portion of the house: by straightening out the facade by rotating the two diagonal halves about the cylinder of the stairs, a base results that replicates the spaces associated with the three-branch movement described above. The "unexpected" configuration of the spaces associated with the pastor is thus given a rationale: the pastor's spaces can be thought of as the result of a doubling or stretching of the traditional residential space-pattern to obtain new spaces required by a unique program. But the most important facet

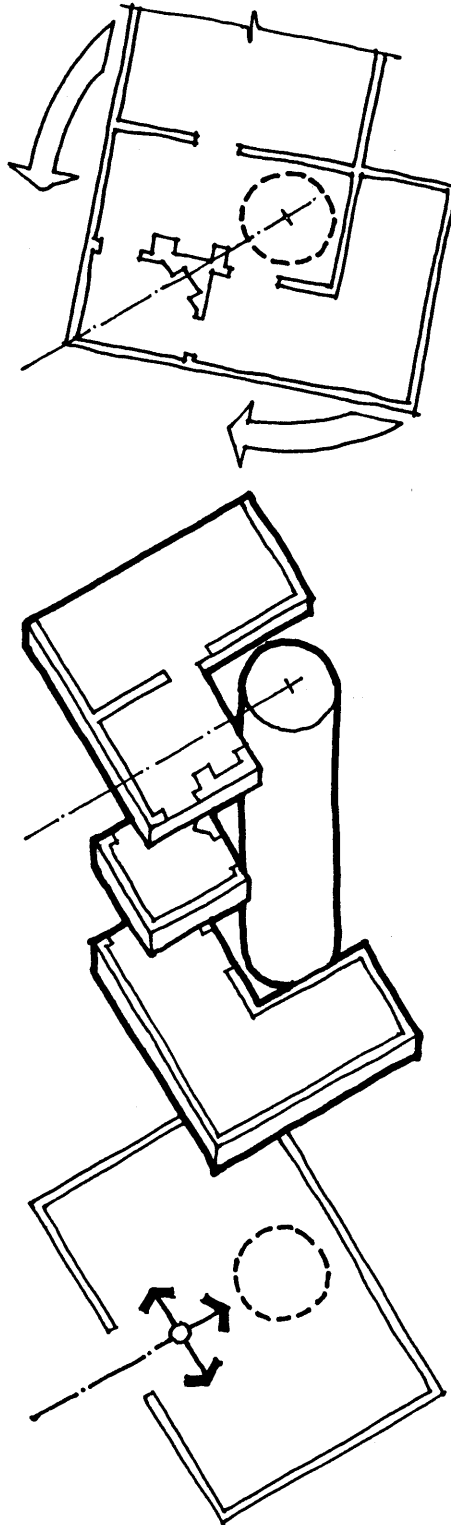

of this reading is that even though one is hereby given a reason for seeing these spaces as a group, one cannot reasonably imagine the group broken off completely from the whole: in the truest sense of the word, the pastor's spaces are articulated--simultaneously integral and separate from the whole house.

I can, in fact, recap the analysis by illustrating all the possible points of articulation that the analysis makes reasonable. This diagram shows how integration can indeed be achieved through ambiguity: by setting up a whole series of ways in which one could conceptually divide up the space of the house, no one division-scheme can claim priority. And in this way one can see how the unavoidable conflict and ambiguity of the situation of the Browne house has been resolved and manifested in a satisfying, reasonable, and pleasing manner.

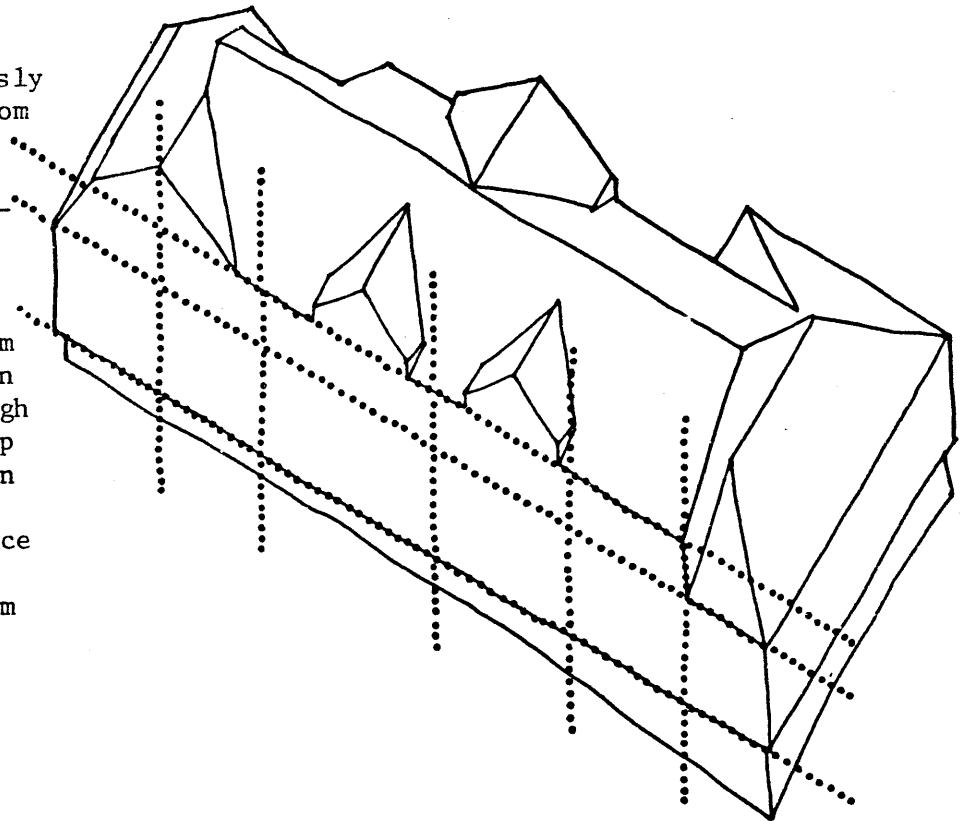

# Renovation Prelude

Two insights can be drawn from the Browne house analysis that have particular importance for the designs that follow. The first is the realization that, in most cases, a given deviation could be seen as an acknowledgement of more than one building aspect; for example, the shift in a portion of the facade simultaneously allowed for the movement of entry, contained the hip roof's formal predisposition, and acknowledged the hillside site condition. Secondly, this acknowledging was achieved not by adding forms that would "express" but which would be superfluous to the actual programmatic requirements of the building; but rather, the acknowledgement was achieved by subtle and not-dysfunctional distortions of only those forms that the building situation called for.

Recalling the earlier concept of the enactive use of space, one can see how these two notions--which might be termed multiple suggestiveness and intentional distortion--describe the character of an environment intended to be used in an enactive manner. In contrast to the aggressiveness of much of modern architecture, these ideals describe an architecture that does not force the viewer, willing or not, to confront its vision of reality, but rather accords the viewer the option of viewing it--and rewarding the willing viewer with a richly-organized repertoire of parts, offered up in such a way that he can not only use as many of them as he wishes and draw from them whatever meaning

he can, but he can also choose to ignore them and not use them at all.

More specifically, in the case of objects distorted to reflect intentionality, by virtue of their being also objects for use, the viewer is not forced at all times to see them as objects for expression; but rather, when he wishes to, he may exercise his option to contemplate them on whatever level he chooses. For even in the case of interpreting these intentionally-distorted objects, the viewer is accorded freedom of action: multiple suggestiveness assures that there can be no single "correct" reading to which the contemplative viewer would be limited.

The question now arises as to how one would manifest forms in such a way that they possessed these two desired characteristics. Some possible strategies for achieving multiple suggestiveness and intentional distortion are discussed below; all of these strategies--and others as well--are utilized in the designs that follow this section.

#### SUGGEST MULTIPLE USES

One can see that, as a vehicle for the accommodation of a maximum of uses, a multiply-suggestive space stands as an alternative to the anonymous "universal" space in that, while both represent the attempt to avoid the situation in which forms would favor one particular activity to the exclusion of all others, the strategy of the anonymous space is to avoid the suggestion of any activity, while that

## Intentions and interpretations.

Note that I have not said that the object should reflect the intentions of its designer. This study has consciously avoided the whole issue of "what the artist meant," both because I feel that second-guessing the artist has little to do with the type of ordinary-but-informed perception I have been discussing, and because I am concerned with assuring building-users the maximum freedom, both of action and imagination. I feel that it is important, however, that the ordinary viewer not read profound meaning into an object that is purely utilitarian or expedient; I likewise feel that the viewer should not impute a structured import onto an object that is the product of mere caprice. Thus I am proposing that the goal of the viewer should be, not to find the specific intentions behind an object, but only reasonably to establish that it is intentional. From this proposition flows the goal of reading only intentional (and thus non-expedient) distortions

of only those objects required by the building situation (and thus non-capricious).

Also note that this is an ideal, a goal toward which to direct one's efforts but which one would never achieve in practice.

This idea is approached from a different perspective--and more fully discussed--in the second presentation on pages

of the multiply-suggestive space is to suggest a range of possible uses. But what is more, multiply-suggestive spaces exhibit a kind of synergy in that, by providing a rich array of cues, the space allows the user to assemble not only those combinations of cues foreseen by the designer, but also to make other combinations for use in staging activities unforeseen in the program.

In actual practice, of course, the extent to which a space can be multiply suggestive is limited by at least two factors--the equipment it contains and its absolute size. But both of these limitations can be partially overcome by the design strategies discussed below.

#### PROVIDE IGNORABLE EQUIPMENT

It is often the case that an activity to be staged in a space will require the use of facilities specific only to that activity; this equipment might range in size and permanence from built-in cabinets used in cooking through large wardrobes for dressing to portable projectors for showing slides. But in any case, the ideal of multiple suggestiveness implies that the specialized equipment should be configured in such a way that, when other activities are taking place, the users of the space can "ignore" that equipment's implications of a different activity. This goal might be met by making the equipment unobtrusive or literally concealable, but it also might be achieved by making the equipment itself suggestive



of multiple readings--for example, the sink that can sit easily in the bedroom because it is set in the counter of a vanity that looks like any other piece of furniture.

#### SUGGEST SPACE-COMBINATIONS

Different activities seldom fit congruently into the same enclosure; their performance nearly always requires different amounts of actual space. The conventional way of addressing this condition is to provide enough space for the most demanding activity and let the other uses occupy their requisite portions of the same space. But the basic theme of optional regrouping suggests that another strategy might be to manifest spaces in such a way that they could (conceptually) be thrown together into many possible combinations, each of which would be of a size more nearly appropriate for the activity to be staged. This concept is the embodiment of the idea of articulation, and an illustration of this ideal of regroupable spaces--and the notion of ignorable equipment as well--is provided by a design for adaptable housing by the Building Systems Group in London. In this scheme the kitchen and bath are kept unobtrusive, being placed at one end of the unit, and the equipment of closets has been manifested as portable wardrobes--with the dual result that, by appearing as pieces of furniture, their presence can be ignored, and by being portable, no room is irrevocably marked as only a

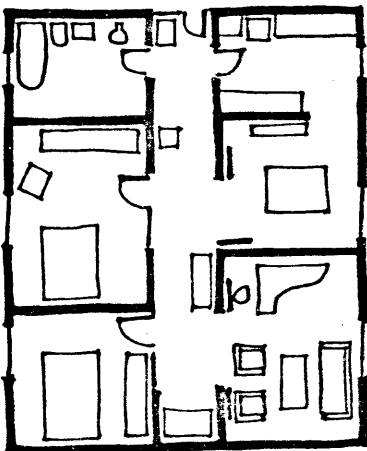
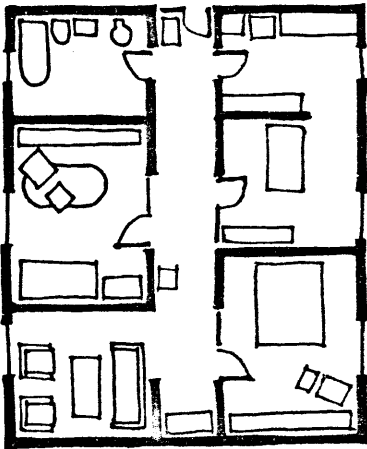
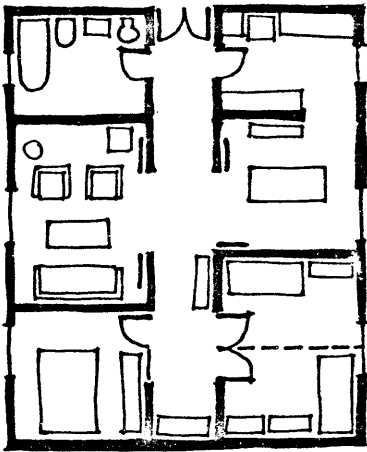

# Economics of adaptability

The Building Design Group found that, in their design, this kind of multiple suggestiveness did exact a premium in that the unit required more absolute square footage than that specified by minimum standards. But the Group also found that, when compared with other schemes to achieve flexibility (provision for additions, movable walls, and so on), the strategy of unclassified (but larger) spaces was cheapest. See Architectural Design, 2/74, pp. 79-90.

bedroom by the usual built-in closet. The design also points up one method for joining spaces with an optional articulation through its use of the full-height double door that a space-user can view as a wall (both doors closed), as a conventional door (one door open), or (with both open) as an ignorable seam in a continuous space.

One can see that the preceding examples deal with the issue of the differing uses of space that occur during relatively short periods of time. But the design principles also have implications for designing for the long-term use of space--for history. If one holds to the ideal that an environment ought to offer the viewer the maximum number of options for both use and interpretation, then it follows that, in the renovation of an old building, the suggestions of uses and readings embodied in the existing forms ought not to be replaced but rather maintained and added to. That is, when one renovates a space for a set of new uses, the principle of multiple suggestiveness implies that not only should the new forms offer their own multiple suggestions of uses and readings, but one should try to maintain those cues-from-the-past that would suggest additional optional uses to the enactive user and optional readings for the contemplative viewer. Likewise, the ideal of intentional distortion implies that a renovator would limit his field of intervention: that is,

just as he would not provide forms whose only role was to "express," so he would not provide forms whose sole function was to "reflect today" (the mullioned window reglazed with a single sheet of glass being a prime example), but rather, if an existing form, by virtue of its multiple suggestiveness, could accommodate a necessary new use, it would be maintained: the designer ideally would limit his interventions to those forms programmatically required to supplement the existing fabric: from out of only those necessary forms the designer would choose the ones which he would distort to suggest optional interpretations.

The ideal is thus one of transparent or ignorable intervention, a condition in which the new forms would offer their own suggestions of use and interpretation but would be disposed in such a way that the suggestions offered by previous forms would also be visible. In essence, the ideal is that the building be a layered record--a palimpsest--of its own history.

The list of strategies thus continues with methods for making ignorable interventions:

#### BRIDGE THE GAP

If the programmatically-required new use for a space called for more absolute area than was available in the existing room, the designer might provide a suggestion that the room be joined (conceptually) with an adjacent room. This might be done with continuous surface materials or a

piece of shallow furniture placed in the opening--two interventions which could be ignored at will.

#### SUGGEST REDIVISIONS

Conversely, the design might offer the suggestion that a space too large for an activity could be (conceptually) divided into smaller spaces. This headboard/closet suggests such a redivision while still allowing one to imagine the space as whole.

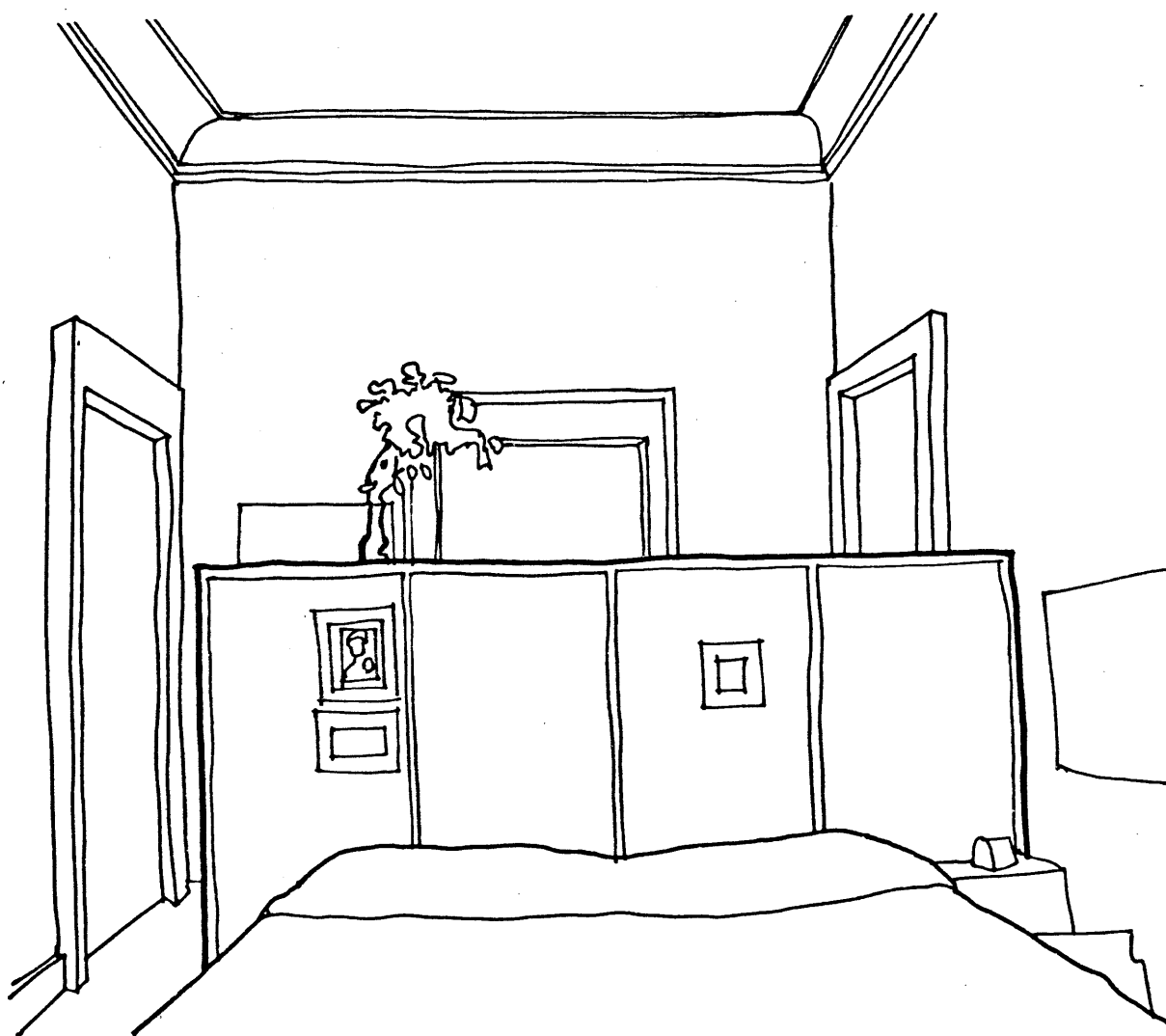

## ADD TRANSPARENTLY

One could also add to the surfaces of a form in such a way that both the necessary addition and the original face were visible. The columned shop-front shown here bespeaks its own time but does not obliterate the older house to which it is appended.



### OVERLAY THE EQUIPMENT

Besides articulating a single space, the headboard/closet also represents the ignorable insertion of equipment into a space. In similar fashion, one could attach equipment to the surface of a space so that, while the extent (and ideally, the use) of the original enclosure were still apparent, an additional use would suggest itself to the viewer. (With perhaps too much difficulty) one can imagine the grand entry hall into which this kitchen equipment has been inserted.

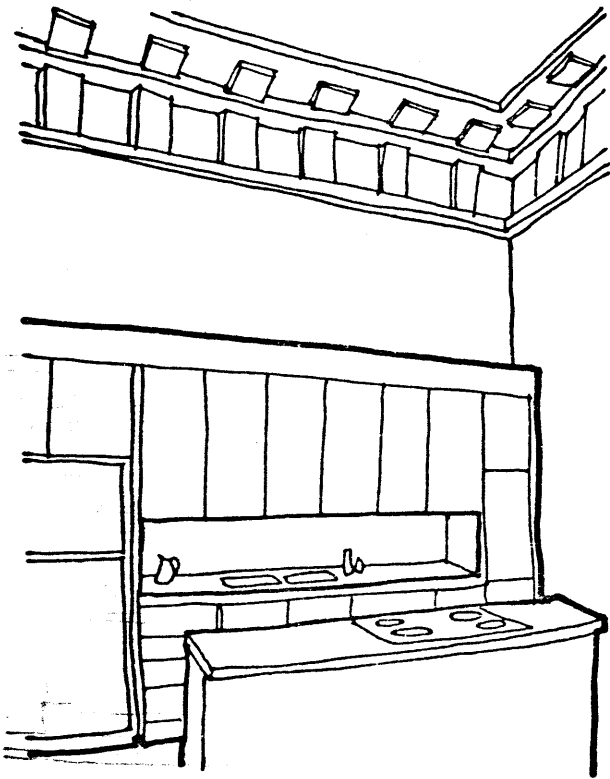

### REUSE THE EQUIPMENT

As stated earlier, if the old form can be reconceptualized as such, it should be used as the accommodation for a new use. Here, in a factory converted to a school, a bank of cabinets for spare-parts storage is reused as a resource center for educational materials.

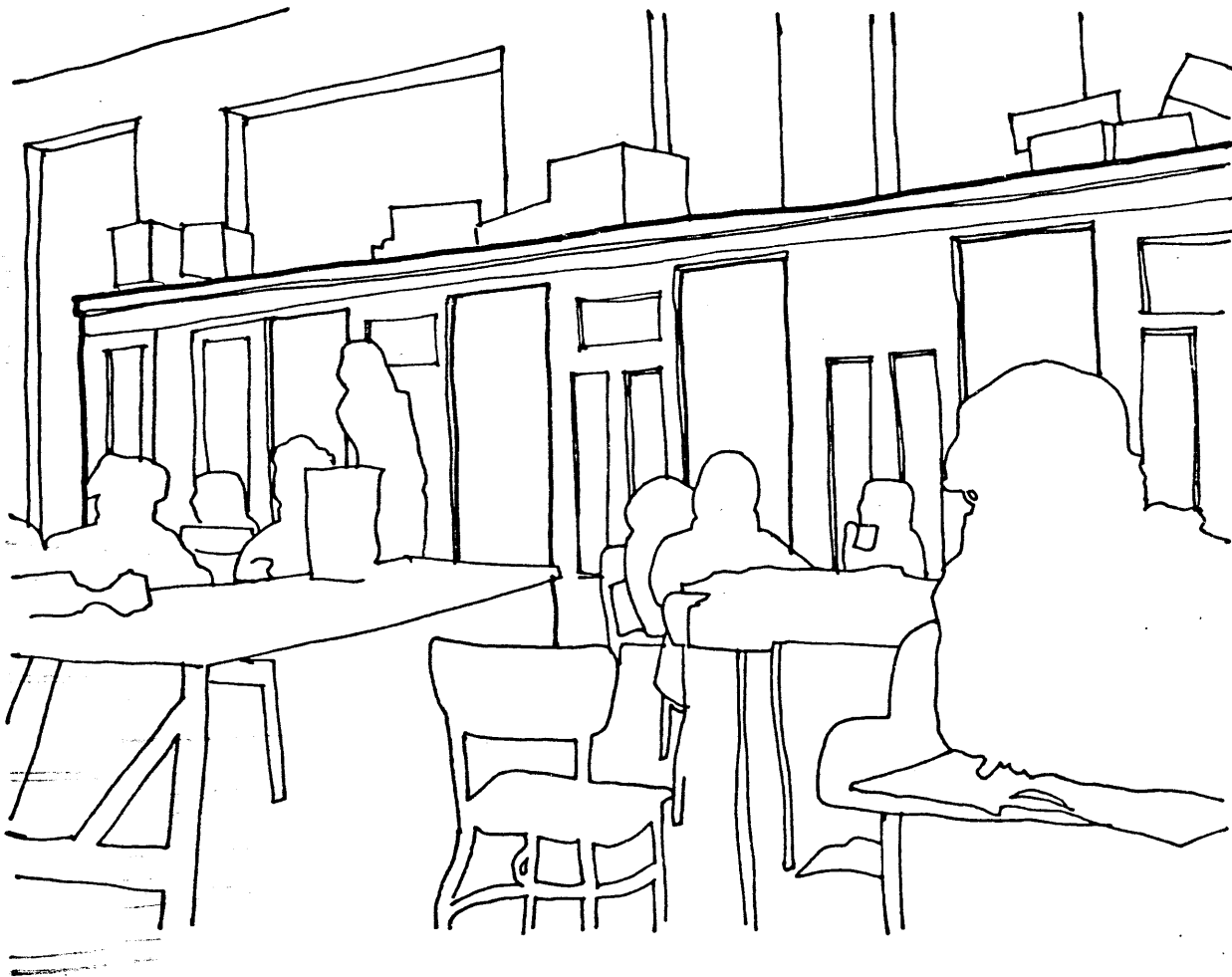

### ARTICULATE THE EQUIPMENT

And equipment can also be articulated so that several new functions are suggested while the original cues remain visible. This barn door can still be seen as what it was intended to be, but now it also accommodates a front door and a window.

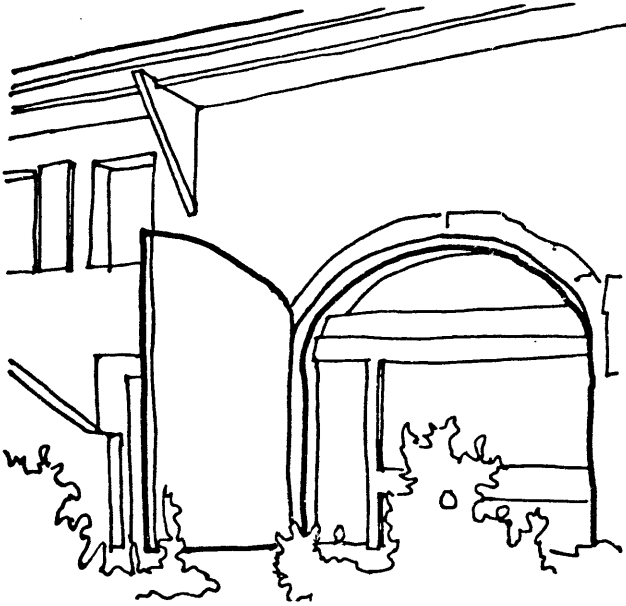

Other strategies exist, of course, and examples of some of them (and suggestions of yet others) will be illustrated in the following designs.

### Footnotes.

Once again, individual ideas are difficult to isolate and attribute, but I should say that the notion of "equipment" comes from a conversation with Donlyn Lyndon; the theme of distortion to mark intentionality has its source in a conversation with Peter Eisenman; and, although the concept had occurred to me at an earlier date, the felicitous phrase "building as palimpsest" comes from the special European Heritage Year issue of the Architectural Review (11/75).



I have said that a building ought to be a reflection of its situation. As mentioned in the preceding section, the forms of a renovation (under this assumption) ought to be reflective, not of a completely resolved summation of the new situation, but only of those aspects of the new situation that the original building cannot accommodate. For the purposes of demonstration, this hypothetical renovation, although it is to be seen as taking place in the present, will take as its starting point the original condition of the Browne house. Thus, the major changed aspects of the building situation are site conditions and program. As for the site, there are now houses a few yards to the left and right (forcing the driveway into a straight-shot configuration), and the meadow behind the house is now a pine woods. The inlet, however, is still clearly visible, due to the still-apparent prominence of the house's hilltop location.

But the hypothetical program is the major change: the house is to be modified to accommodate two dwelling units for rental to families on a year-round basis. It is assumed that occupancies will be rather long-term and that the tenants will both share some of the facilities of the house and cooperate on certain matters of maintenance and groundskeeping. And (in a true hypothetical leap) it will be assumed that both the owner and his tenants fully realize and value the qualities of this Richardson house!

# First floor.

For reasons that will be made clear in the discussion of the design, I wish to avoid assigning the conventional names to the rooms of the renovated house. For now, let me say only that entry to both units is through a shared hall; the individual units are then entered by separate doors that open into a part of the living space, beyond which is a kitchen and an area that can be used for eating.

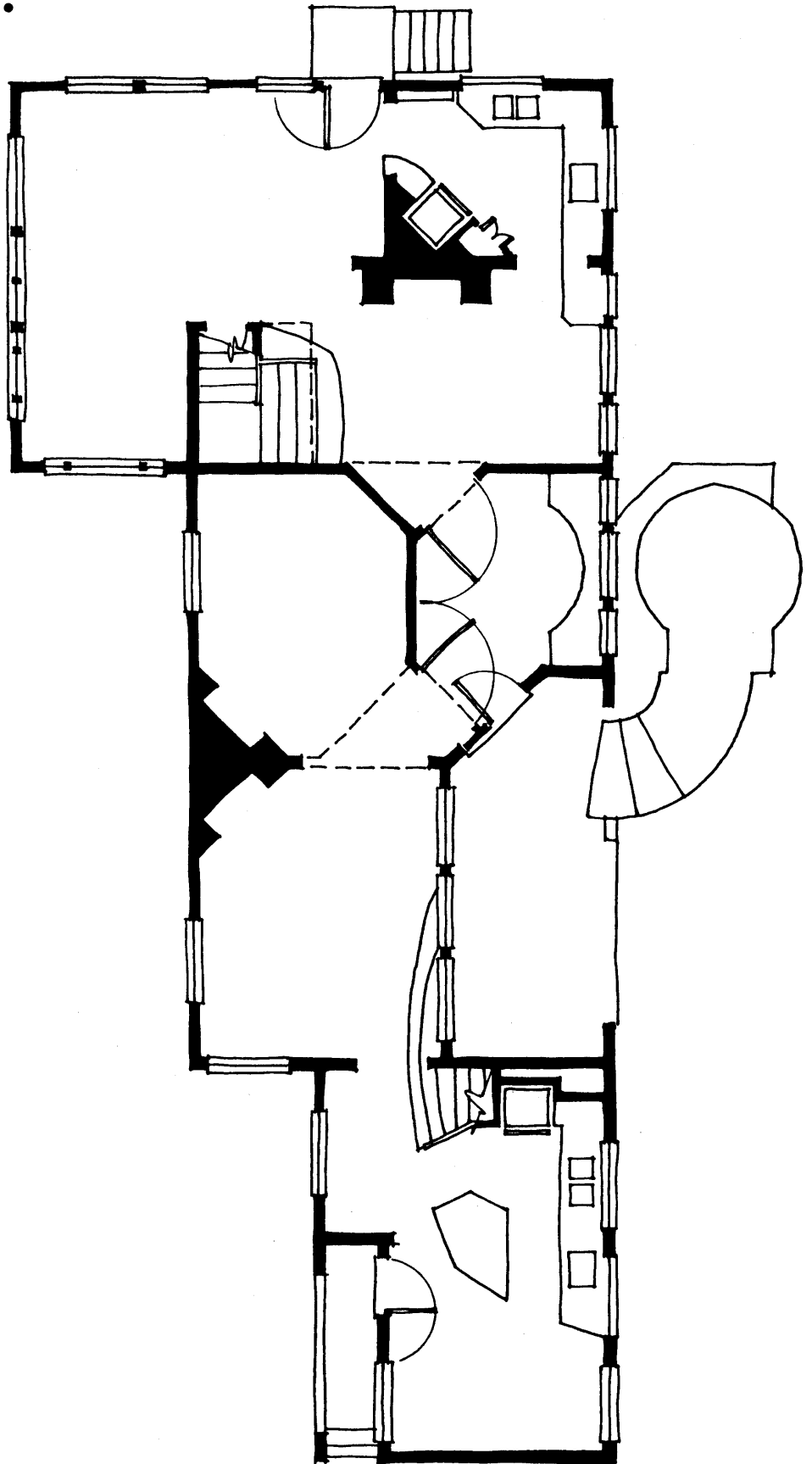

## Second floor.

The plan provides four bedrooms; the extreme right- and left-hand rooms would serve the units below them; either of the two center bedrooms could be rented with either unit by locking the appropriate doors.

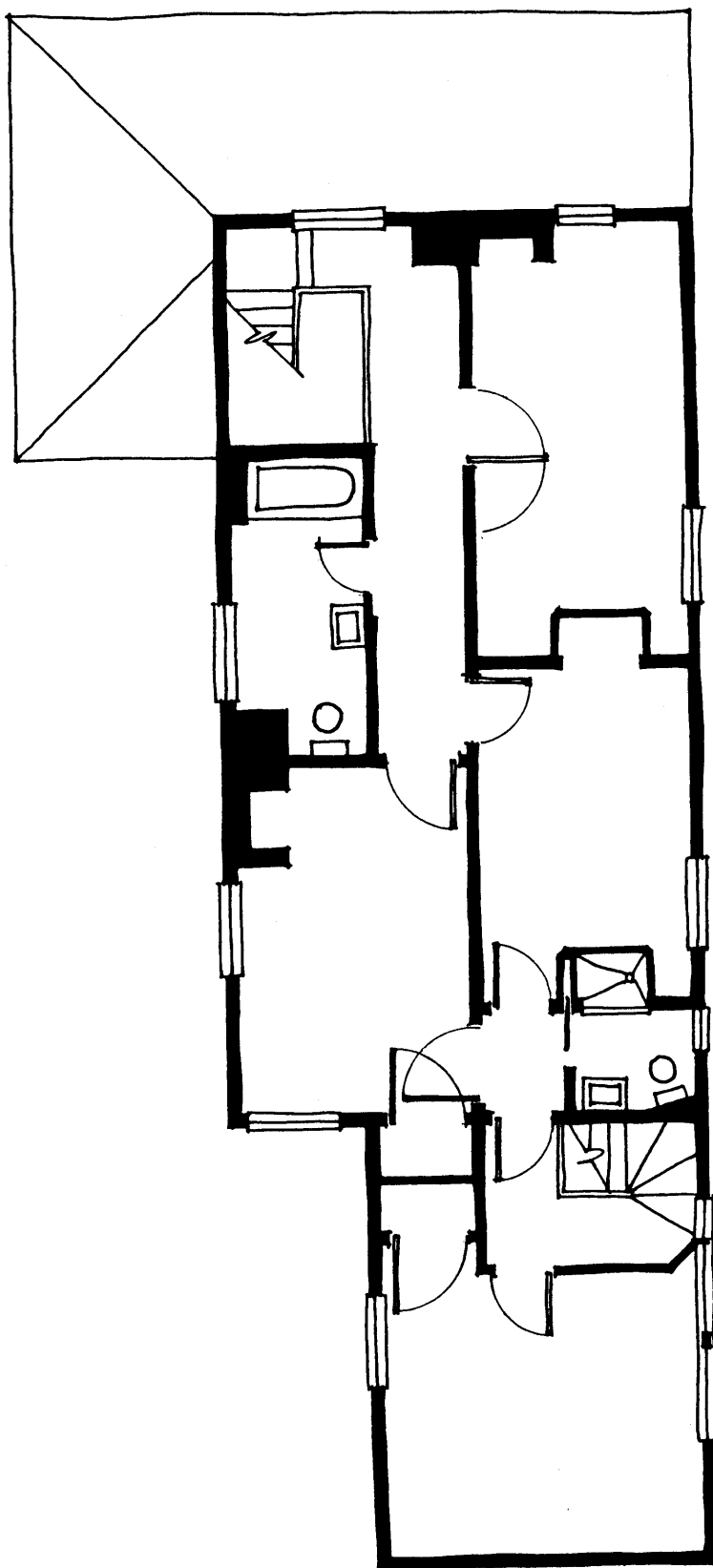

Note that this view and the sketch that follows it are somewhat schematized, particularly as regards the windows, which represent not new single sheets of glass, but merely new storm windows through which one could still view the original mullioned sashes.

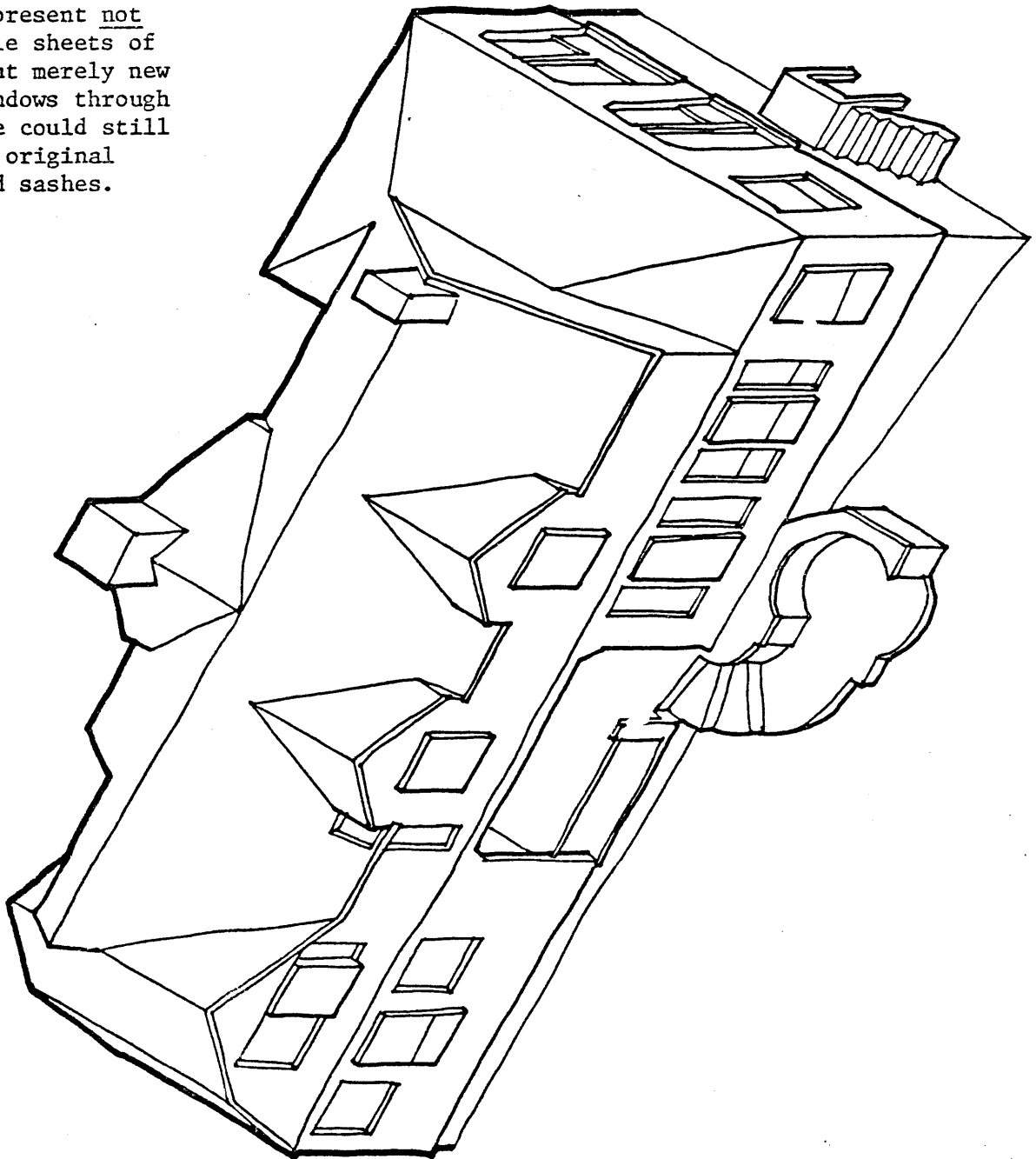

# Discussion of the design.

As a reflection of the notion that different mental spaces can be conceptualized at separate times within the same enclosure, the two units share an entry hall on the first floor that is to "belong" to one or the other unit at the appropriate times; that is, a guest of either tenant would be received at the (shared) front door, ushered into the entry hall, his wraps taken, then escorted through the appropriate (and temporarily open) door into the main spaces of the individual unit. The space could likewise (by mutual consent) "belong" to one of the units during, say, a large party, serving as an articulated space, separate from but integral with the rest of that unit.

This condition, combined with that of the two bedrooms which can be rented with either unit, means that on both floors spaces exist that can be seen as claimed by both units. This overlapping is marked, in both cases, by a small distortion of the new storm windows that one might assume would have been required in any case. On the first floor the three large windows on the right-hand side are given

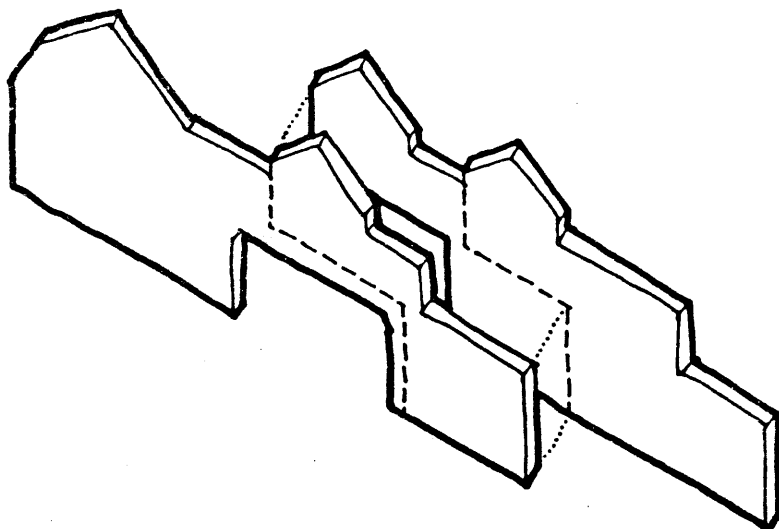

storm sashes that project from the window-frame, while the narrow windows are covered with sashes set in from the frame. The projecting sashes can thus be seen as a group that reflects the volume behind it.

Another reading arises when one notices the mullions on four of the right-hand windows: in the case of the two windows on the extreme right, these occur at the place where the kitchen counter crosses the windows and separate the clear glass above from the opaque glass below. By (intentionally) using this mullion on the two adjacent windows, a second pattern is overlaid upon the first that reflects the extent of the non-shared space of the right-hand unit.

And a third interpretation suggests itself when one notices that (for the same practical reason) the main window in the far left-hand group also has a mullion-bar, setting up yet another possible grouping of mullioned projecting sashes--thus making the projecting but non-mullioned window of the entry hall appear exceptional, reflecting in another way the unique, shared status of the space behind it.

At the second floor another triple of projecting storm windows marks the maximum extent of the left-hand unit, but here the interpretation is more complex. In this case, the forms available

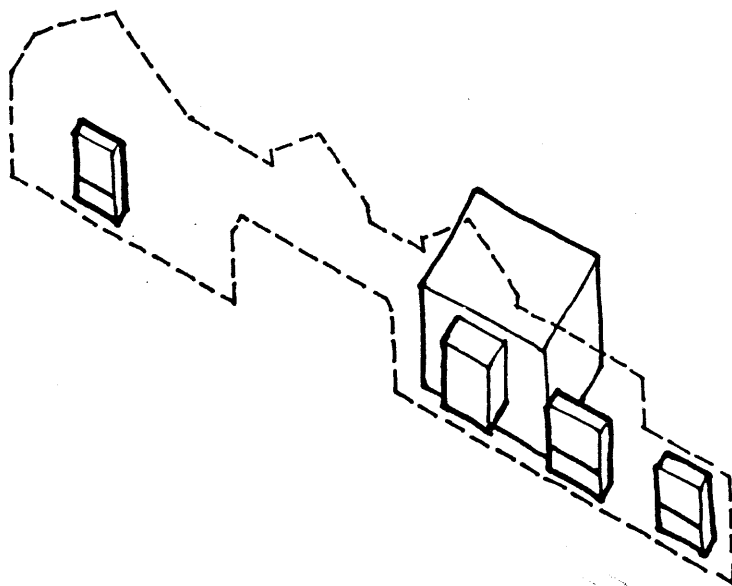
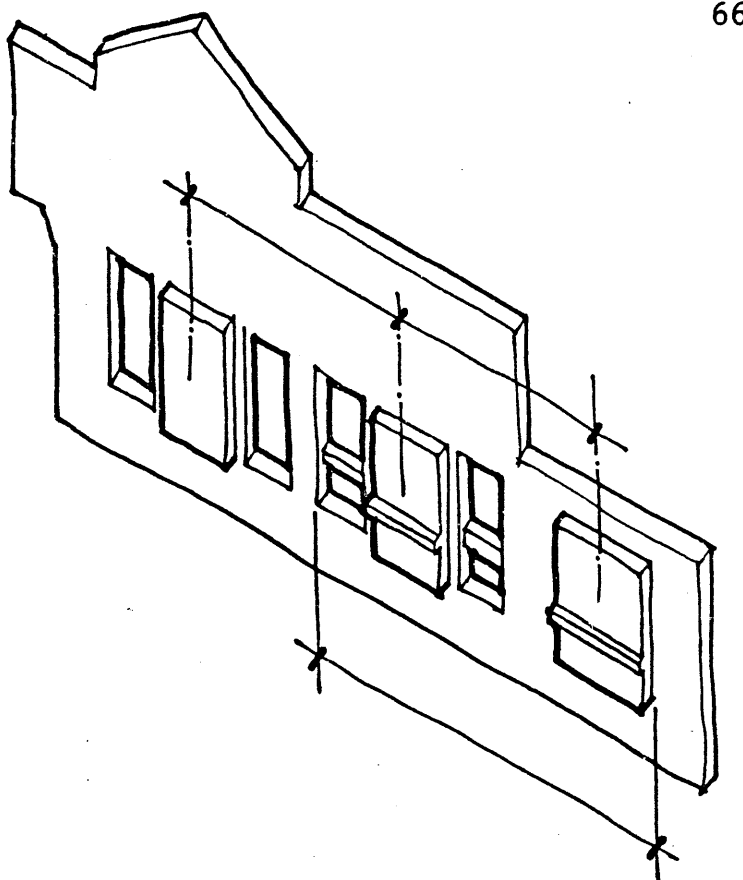

for intentional distortion include two new windows, added to light the new left-hand stairway (rebuilt to meet safety codes) and the new bathroom; these windows, and the storm sashes of the left-hand pair, are then disposed so as to suggest the following interpretation: from a base form of three equally-spaced dormers (the three projecting sashes), the left-hand window moves left, rupturing both facade and roof; the window then stops, but the facade continues to move, scraping out a void (the inset storm sash) and extending itself into its final gambrel form.

(Note that what has happened here is that the new forms suggest both a new base form and a new set of deviations, but in such a manner that the forms that suggest the original interpretation are still visible; thus both readings are possible, the new forms having been transparently overlaid upon the original.)

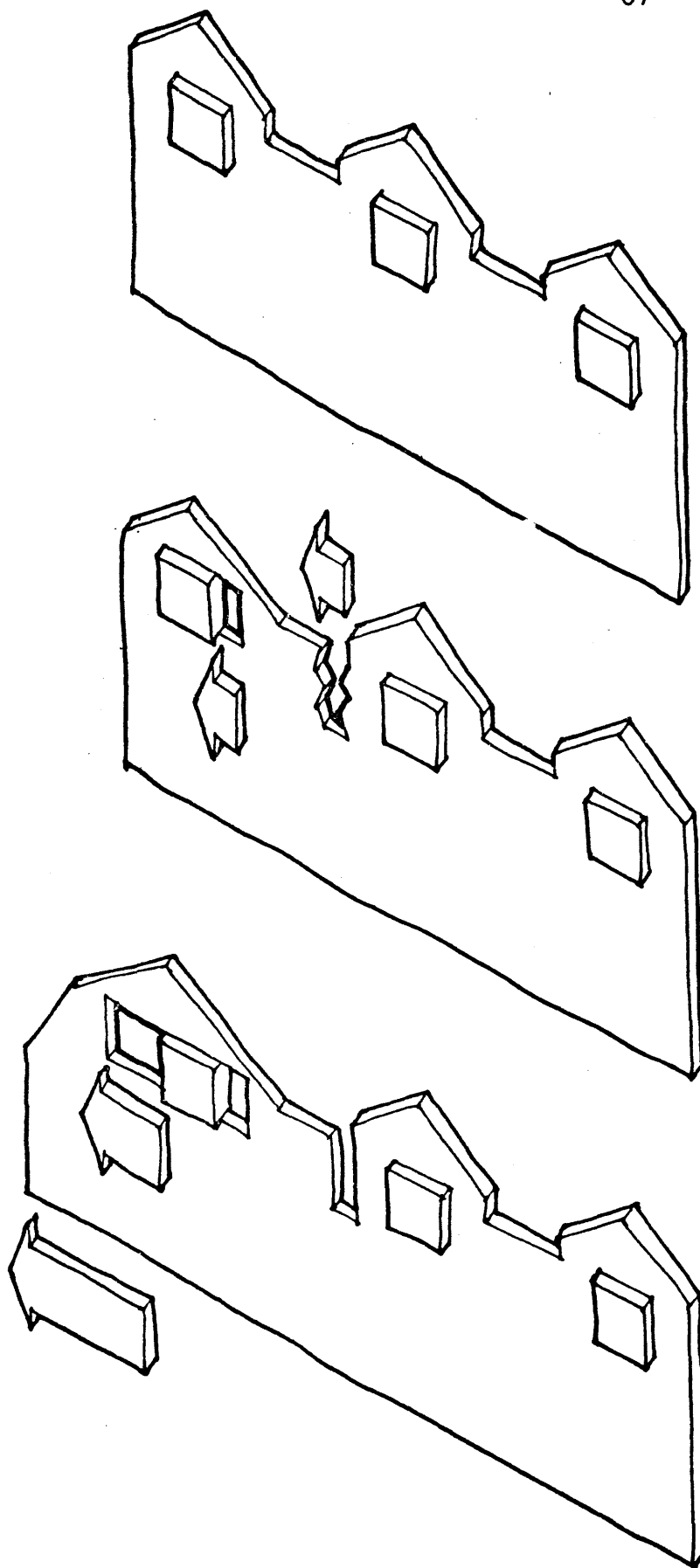

Besides marking the new divisions of the second floor, this interpretation of shifting windows could also be read as a response to the wedging-in of the new bathroom. This interpretation of insertion is further suggested by forms inside the house: here the necessary stall shower is transparently added to the adjacent bedroom, its "ignorability" being aided by its shape, which resembles that of a wardrobe, and by the fact that it does not extend to the full height of the room; further, the form is kept back from the front wall--all of this done so that the viewer can continue to imagine the complete dormer and thus the original (undistorted) shape of the room. In addition, since this bedroom might be included in the same unit with the inserted bath, the insertion is marked again in the right-hand bedroom: the replacement for the closet taken over by the bath is presented to the right-hand bedroom as a wardrobe-like form that is a twin of the shower enclosure; the viewer of this pair thus might explain the configuration by imagining a plug of space being displaced by the insertion of the new bath.

The next problem to be dealt with is that of movement. The goal here is to maintain the entry through the void of the porch (since it is still the case that one enters

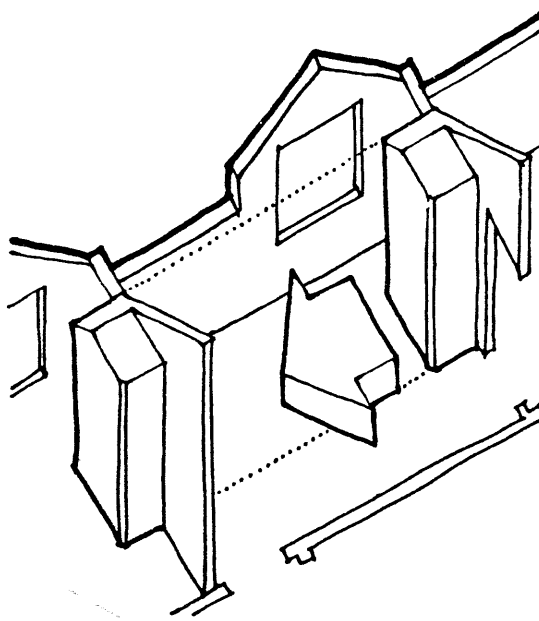
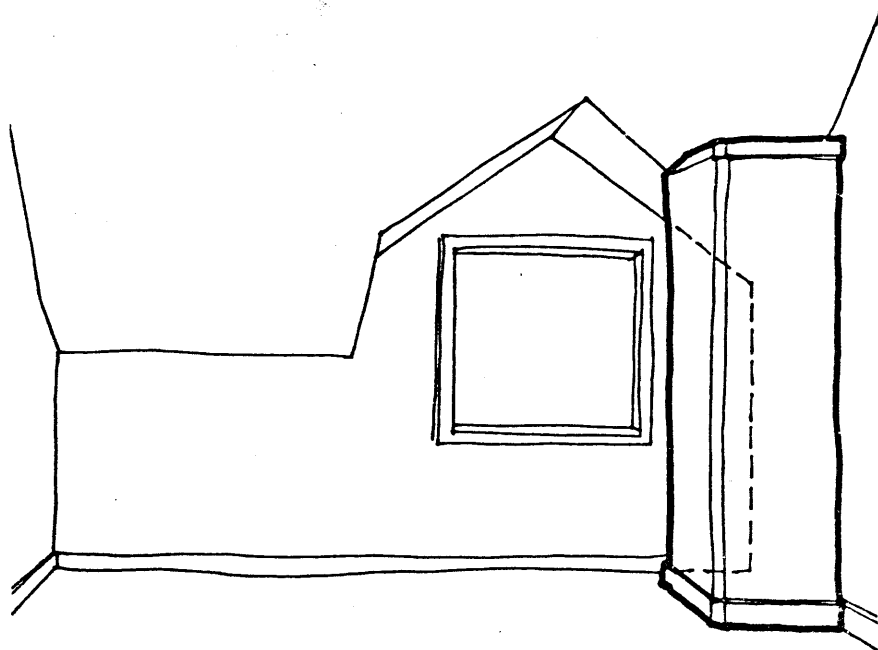



the whole volume) while overlaying the new suggestion of entry directly into the shared entry hall. The problem is thus two-fold: besides marking a new point of (conceptual) entry, the new design must present the forms that carry the actual path of movement into the house in such a way that a viewer might read the path as one distorted from its original course specifically to acknowledge the new conditions of entry.

The manner in which the space of the entry hall is marked as exceptional was discussed above, but the out-thrust storm sash might also be read as an acknowledgement of the pressure of a vector of entry. The circular platform directly under this window can also be seen as a receptor of this entry vector due to its conventionally-assumed formal predisposition; this same factor additionally suggests that the same circle can receive the diagonal vector that represents the direction from which one would actually approach the building (the curved drive, from which one approached perpendicularly, having been abandoned). A viewer might find further acknowledgement of his diagonal approach upon noticing that the base shape of the porch extension duplicates the shape of the original porch; by suggesting that the new platform be seen

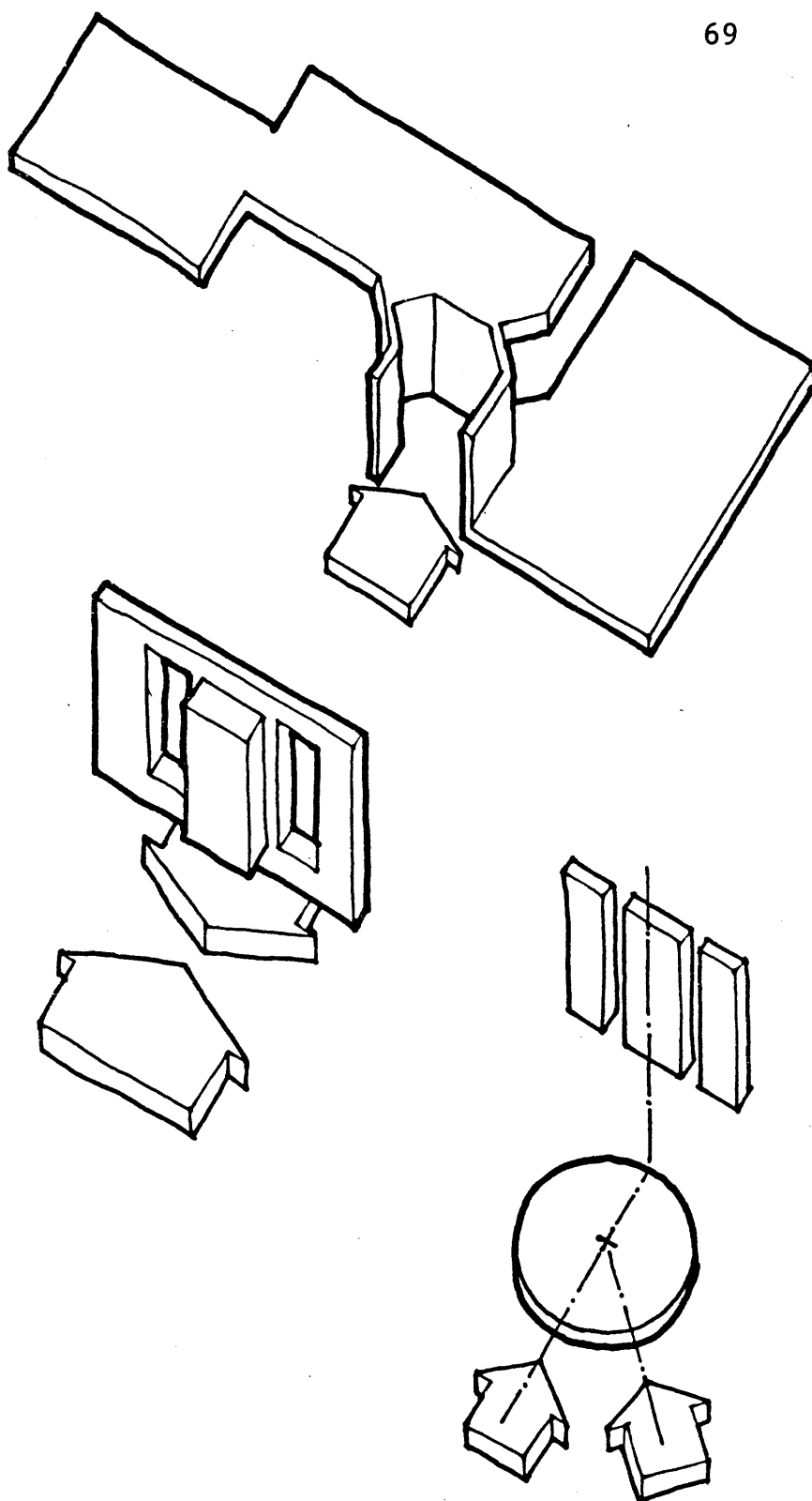

as pulled, drawer-like, out from the foundation in the diagonal direction, one also might imagine this as a kind of doubling of the space of the porch itself, so that, in a sense, one would continue to enter the house via a porch, but now a porch distorted to reflect the new conditions of entry.

Now, having gotten the viewer from his car to the surrogate porch, the next problem is to get him into the house on a path whose distortions-from-the-expected can be seen as reflecting the new conditions. As with the original house, the expected path of entry might be seen as an axial movement to and through a vestibule. The strategy for reflective distortion here will be to suggest a broken or displaced entry; in effect, a situation that might be described by the statement, "My actual path has to go around this wall because of new conditions, but my conceptual path is unbroken."

Both this displaced pattern of movement and the doubled pattern of the original house involve a kind of blindfolded syncopation--the visitor to the pastor "ignoring" the portion of his path that took him through the family spaces and conceptually welding his passage through the front door to his arrival in the reception hall in much the same way that one would conceptually attach the two ends of the

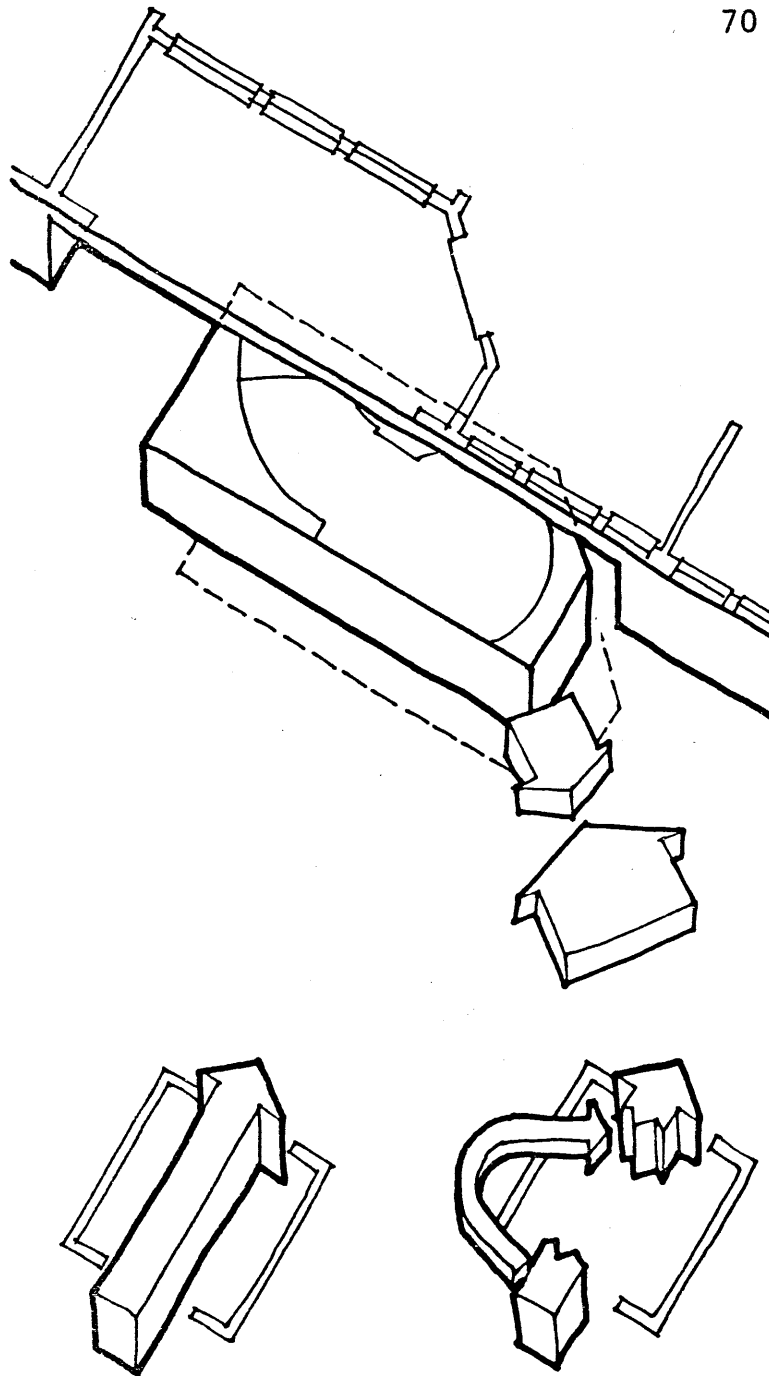

diagrammed entry vector by "forgetting" one's path around the wall. But in order to be "forgettable" in this sense, the path must seem unobtrusive, a natural outcome of the situation. The shape of the bench around the circle aims to engender this feeling of natural movement by turning the path in the one direction left open. The three steps then receive the path and, though incomplete, they suggest the circular movement that carries one to the front door. (The spiral path also suggests another interpretation of the porch extension: that it be seen as pivoted out in acknowledgement of the new circular movement pattern, the center of the stair serving as an axle much like the stair of the original pastor's house.)

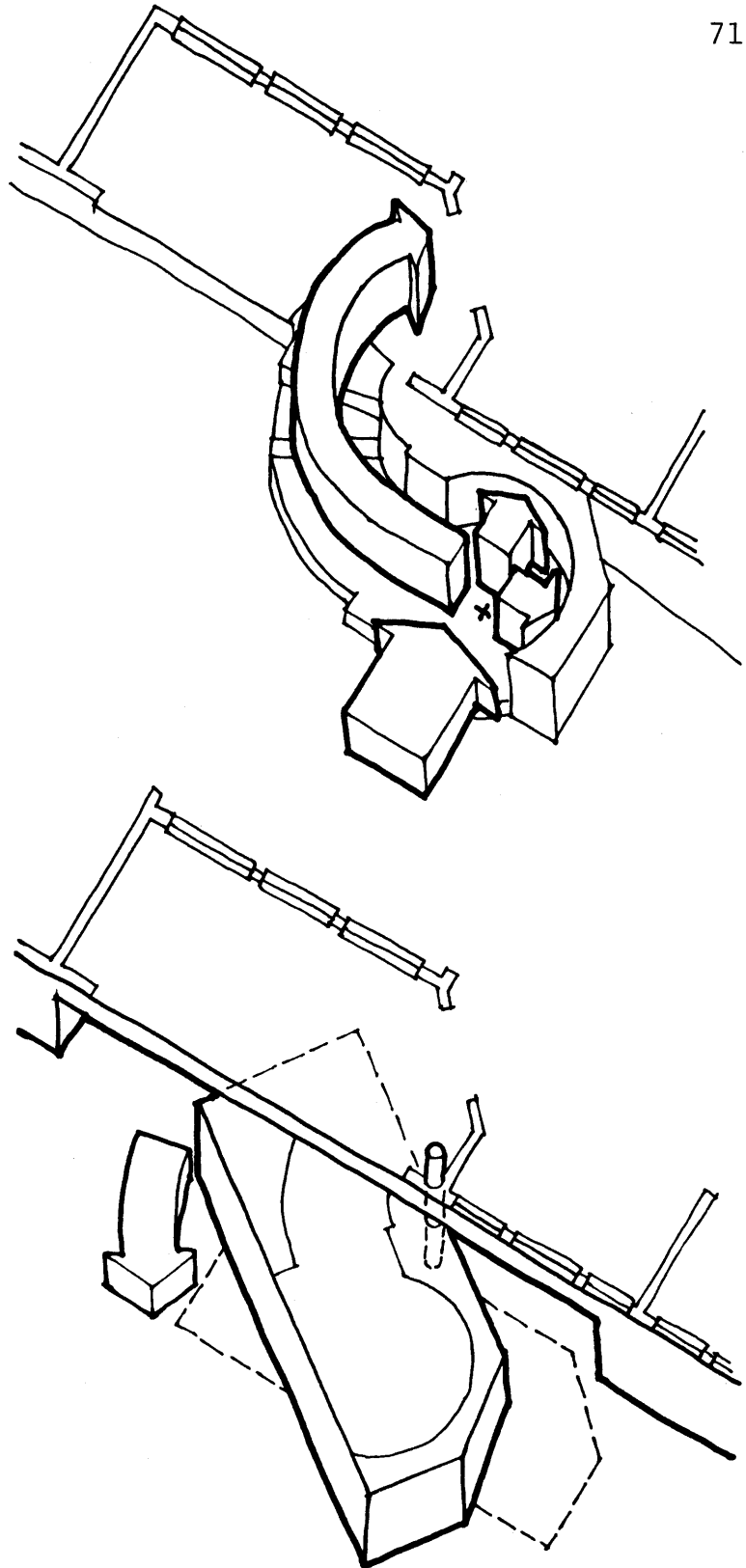

In the (undistorted) entry sequence postulated here, the step that follows one's passage through the front door is arrival in the vestibule. The surfaces and equipment off this vestibule-space have been intentionally distorted to suggest this arrival in three different but mutually-reinforcing ways.

The window seat (besides recalling the original bay) has been given a shape that echoes that of the bench in the porch extension, a shape that can be read as simply a reminder of where the entry path was broken or, in a more drastic analysis, as the completing portion of the circle displaced into the entry hall--enacting in conceptual terms the desired but blocked path of entry.

The flooring pattern raises the possible reading that the entry hall has been racked sideways out of a rectangular base shape--a distortion that can be seen as a response to the rotational movement of the actual entry path.

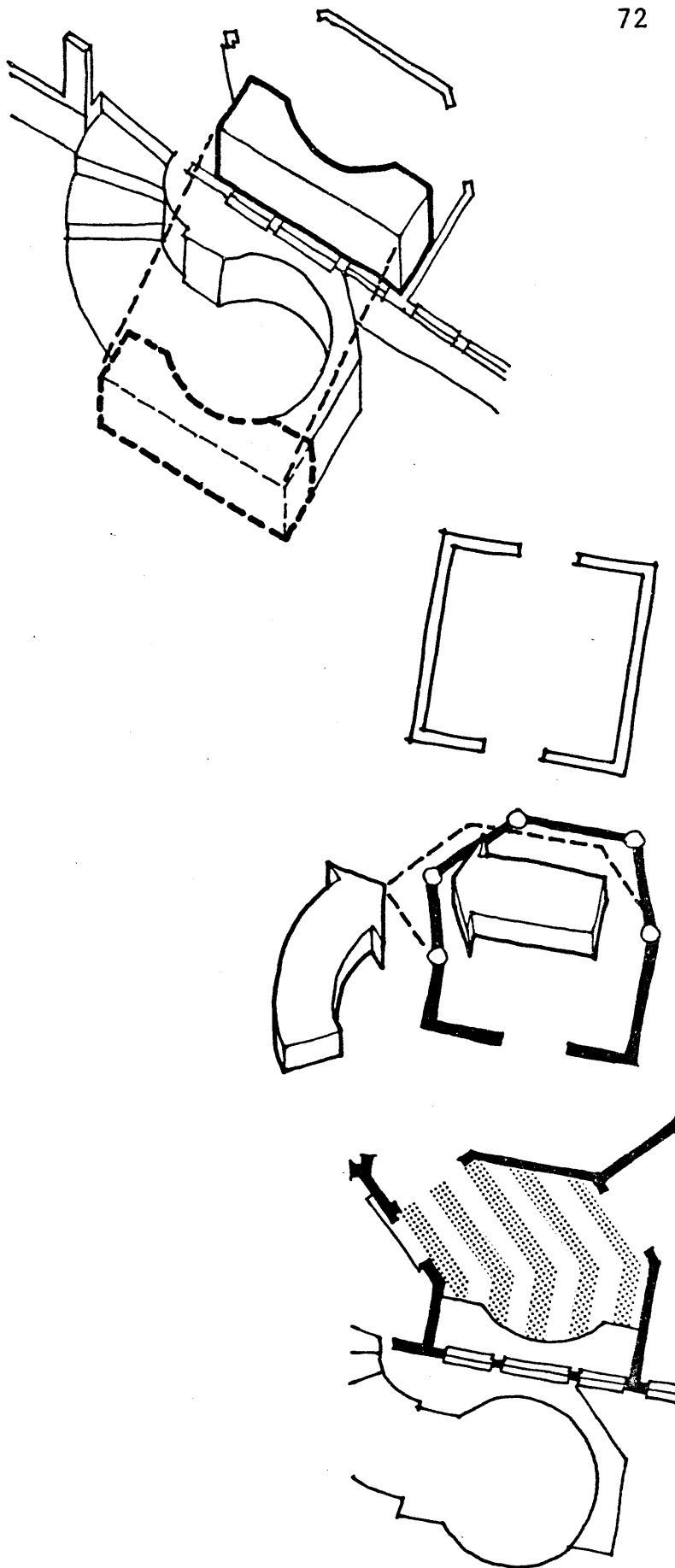

And an acknowledgement of the complimentary vector of desired movement can be read in the symmetrical doors to the two units: their deliberately-inflected moldings suggest that one might view them as a pair of doors pushed apart by the force of the movement vector. Or--alternatively but not contradictorily--they might be seen as having been pulled apart in recognition of the the new dual entry condition.

And finally, even the expected door-swing pattern has been intentionally reversed so that these doors open out from the units themselves and not in to them. The intention here is to suggest that the original door, because it does swing inward, be seen as the actual (shared) "front door" for both units, and that each of the paired doors be thought of as a door between two habitable rooms inside the same dwelling--in fact, that the entry hall be seen not only as a simple vestibule where wraps are taken, but also as a true reception hall, the place where one is welcomed into the space of the home.

Recalling the movement observed in the original house, the next pattern that one might expect would be the three-branched cross of paths that led to the stairs and to the intimate and more public parts of the house. This pattern cannot be maintained exactly, for

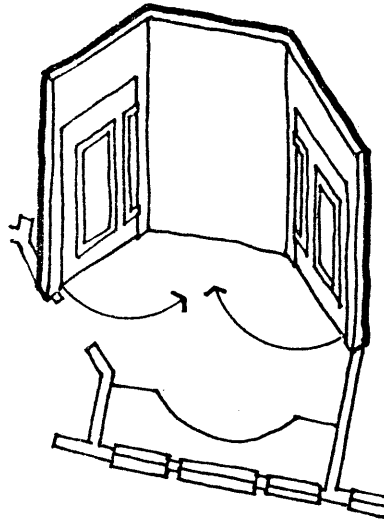
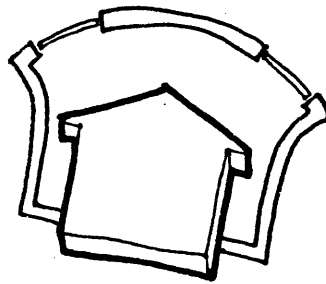
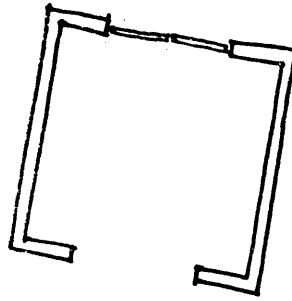

in 1976 the distinction between "guests-only" and "family-only" spaces has become somewhat blurred; plus, the ideal of multiple suggestiveness for maximum freedom (and for flexibility in this rental situation) would rule out such rigid classifications. What is left, then, is a two-branch pattern, one branch to the stairs, one simply to "living space." But as a reminder of the original pattern, I have taken its most memorable path--the straight-ahead axial shot to the stairs--and intentionally emphasized it. Thus, in both units, upon passing through the entry-hall door, one is in a low-ceilinged (articulated) space that, in effect, impels one to "shoot the gap" into the space where the stairs land. To achieve this effect in the left-hand unit, the rebuilt servants' stair has been extended so that, in effect, the foot of the stair is carried into the space next to where actual ascent begins.

The distorted foot of each of the stairs can additionally be seen as inflected toward--and thus recalling--the diagonal axis of the total form.

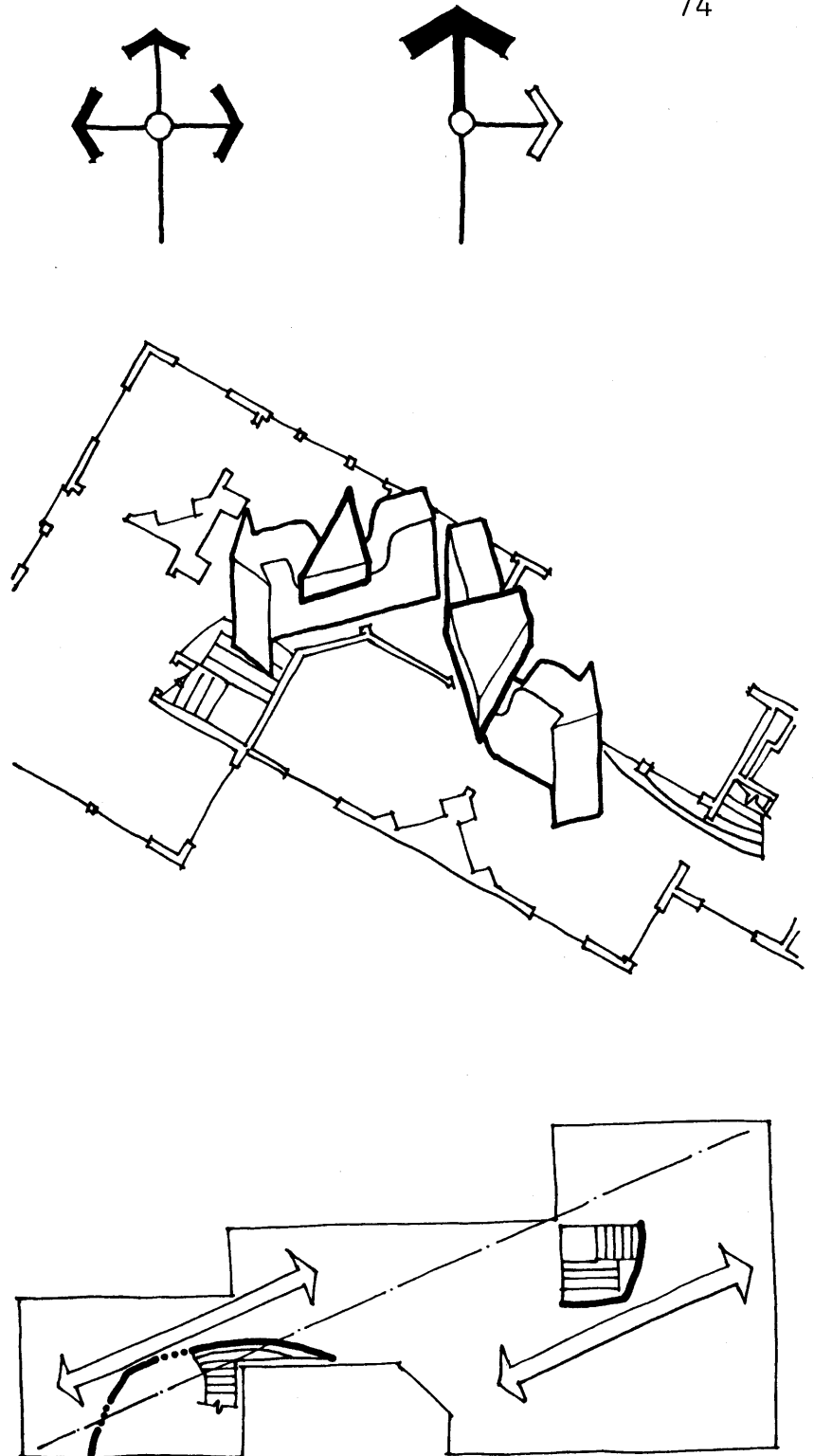

And finally, these distortions can be read as suggestions for the viewer mentally to bridge the gap between the rooms they connect. By exercising this option in the left-hand unit, one could imagine as a single space the stairs, the kitchen, and the nook. A similar combination of stairs, eating, and kitchen is suggested in the right-hand unit by the extension of the kitchen cabinet into the adjacent space as a buffet. (Note in this connection that another, overlaid set of suggested articulations exists in the kitchen/stairs space of the left-hand unit where the original walls have been removed only up to the height of the original door heads--a strategy that also allows the prior configuration to be read through the new.)

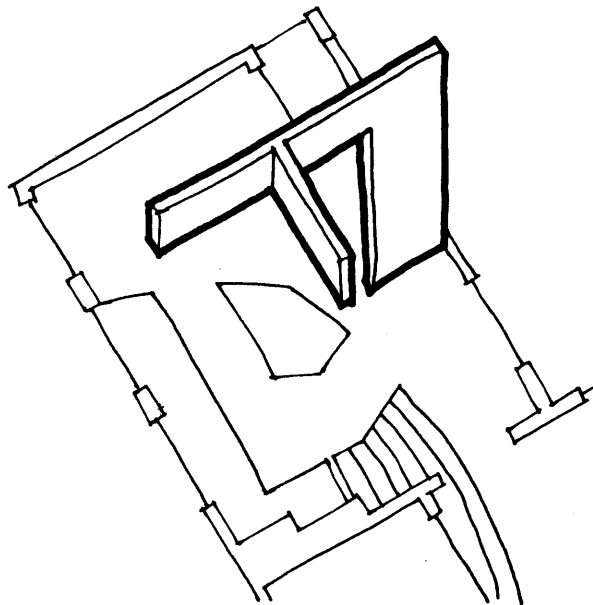
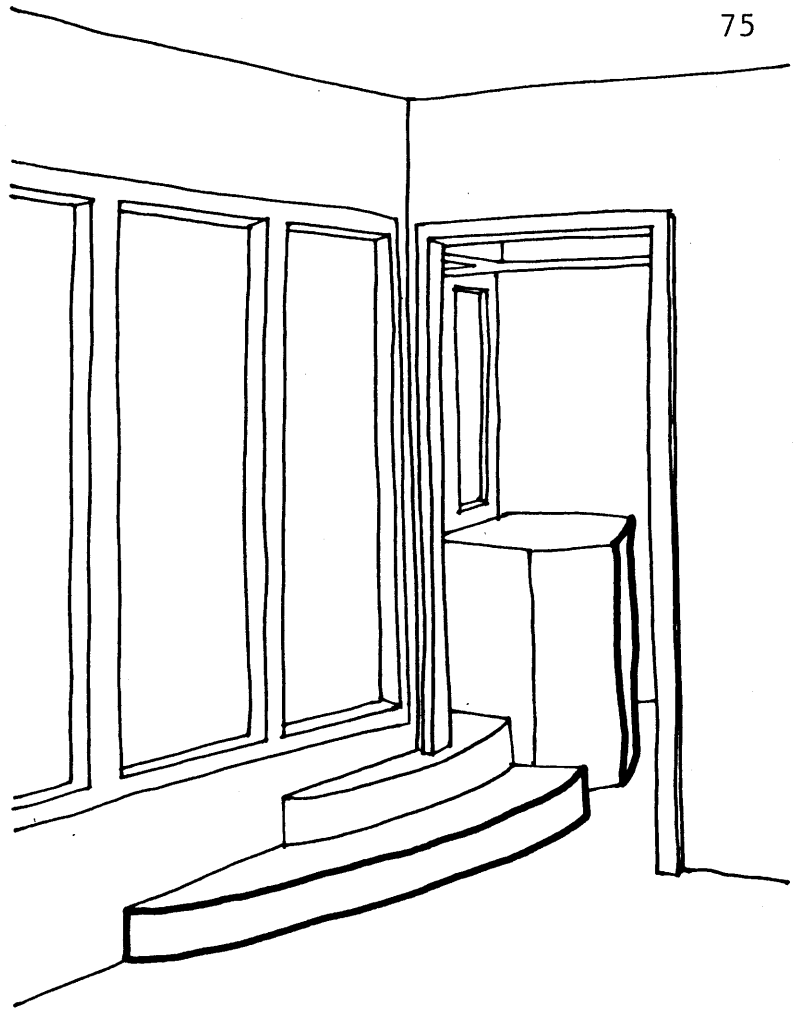

But perhaps most importantly, this strategy of bridging the gap can be the best way of creating large spaces without tearing down walls. Take, as an example, the largest space in the left-hand unit: besides the obvious possibility for linkage with the adjacent space with which it shares the fireplace, by invoking portions of the arc of the foot of the stair, this space can be thought of as linked to the stairs (forming the normal living room through which all circulation passes), or as linked to the kitchen (in which case the space might serve as a conventional dining room), or even as a part of a combination with both kitchen and nook (forming a stretched version of the suburban family room).

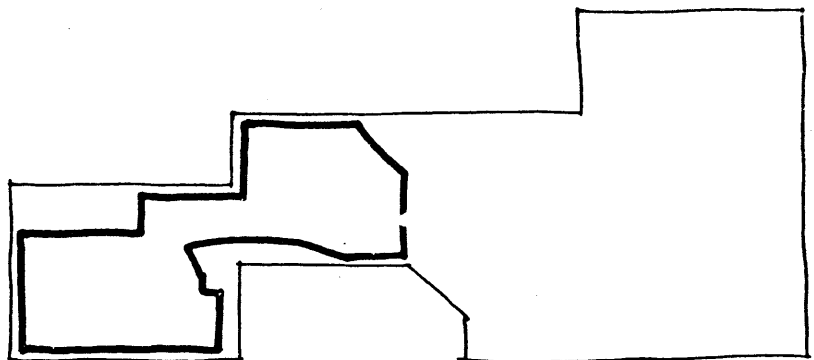
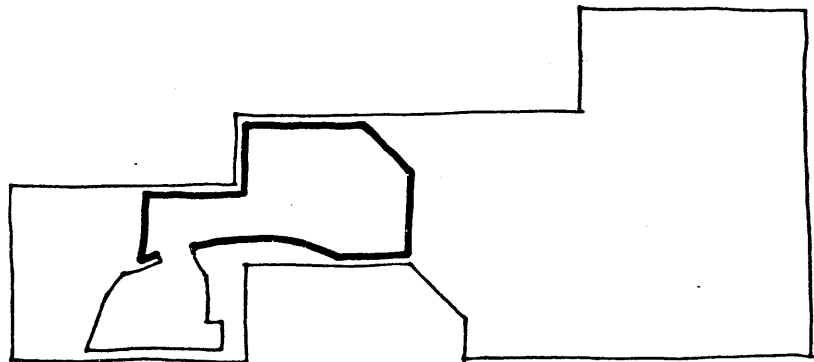
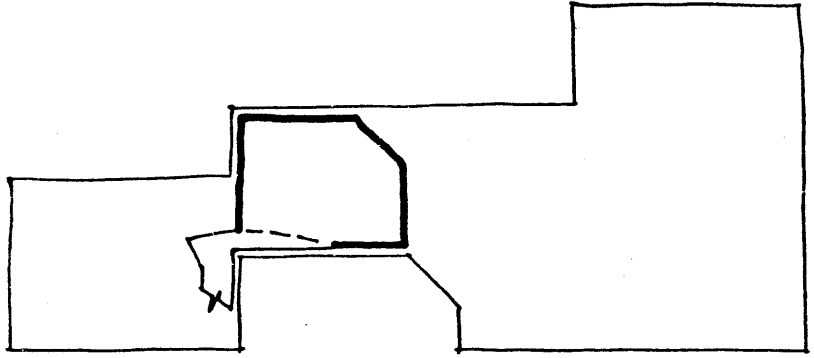



And the same pattern  
of possibilities exists  
in the right-hand unit.  
In fact, yet another layer  
of articulations is  
possible in this unit, due  
to the necessity of

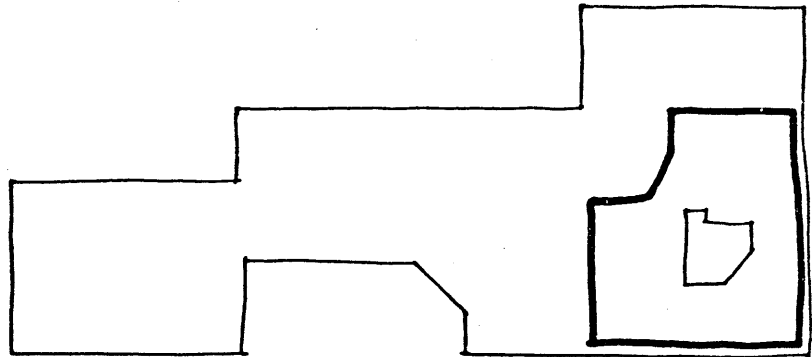
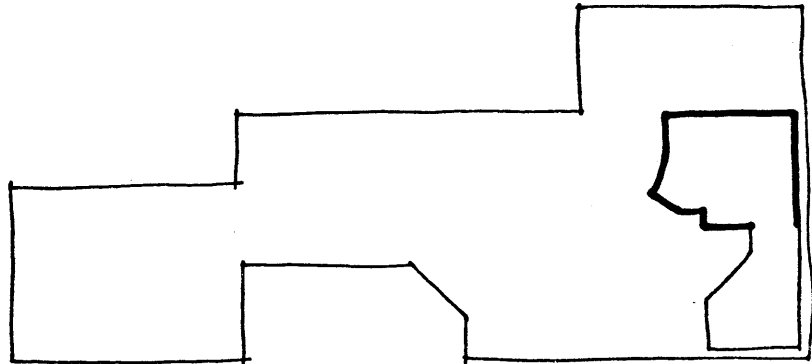
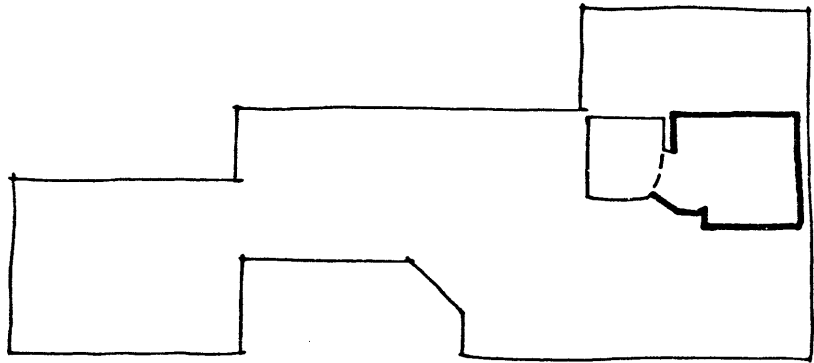

closing in the porch openings: the large opening is glazed in two differing ways, suggesting two possible spaces; and the opening into which the back door is set is redivided like the barn door of the previous section. (In this connection, however, note that the back stairs, though they carry movement, are meant to be only function-accommodating equipment: they are not meant to be read as reflections of anything outside themselves. They are thus manifested in the most straightforward, undistorted, expected form possible.)

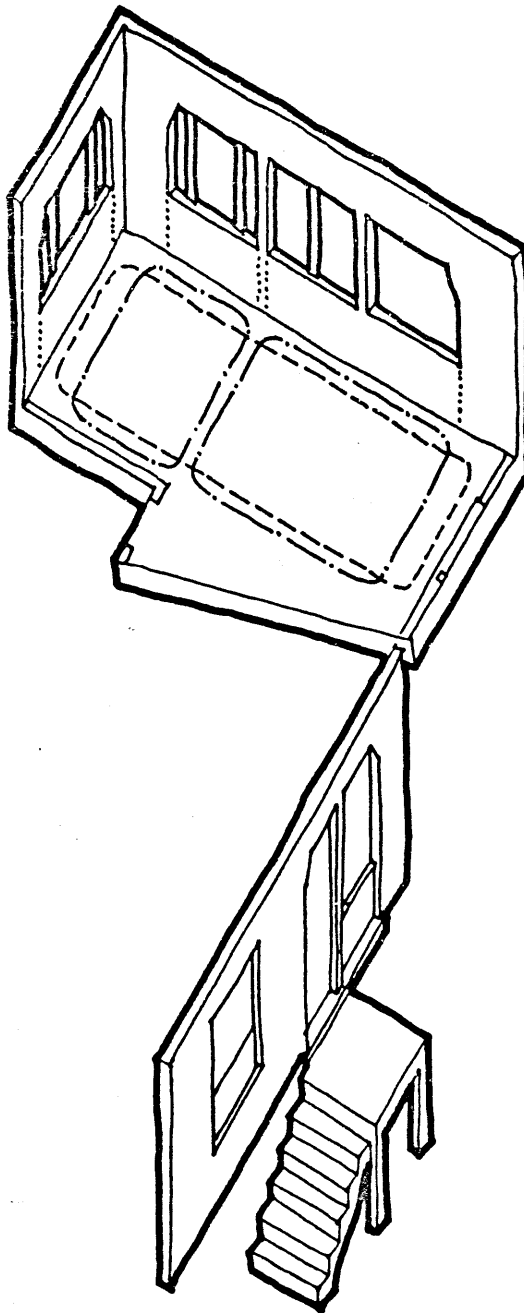

(Returning to the process of recombination) note that this way of reconceptualizing is aided by the fact that the equipment (stairs and kitchen cabinets) is kept to the edges of the spaces and can thus be more easily ignored-- but that countervailing cues exist (such as the extended kitchen cabinet) to suggest that these same equipment spaces can also enter into recombinations.

The realization that grows out of this effort is that the spaces of the interior can be articulated in a manner similar to that seen in the facade of the original house: that is, by setting up a multiplicity of suggested space-divisions, no division scheme (and thus no use-pattern) can claim priority. What is desired, in fact--and what I hope I have partly achieved--is a series of soft-edged "lobes of space" which can be linked in whatever manner is desired, even enabling one to ignore, to a certain extent, the precise configuration of the walls themselves.

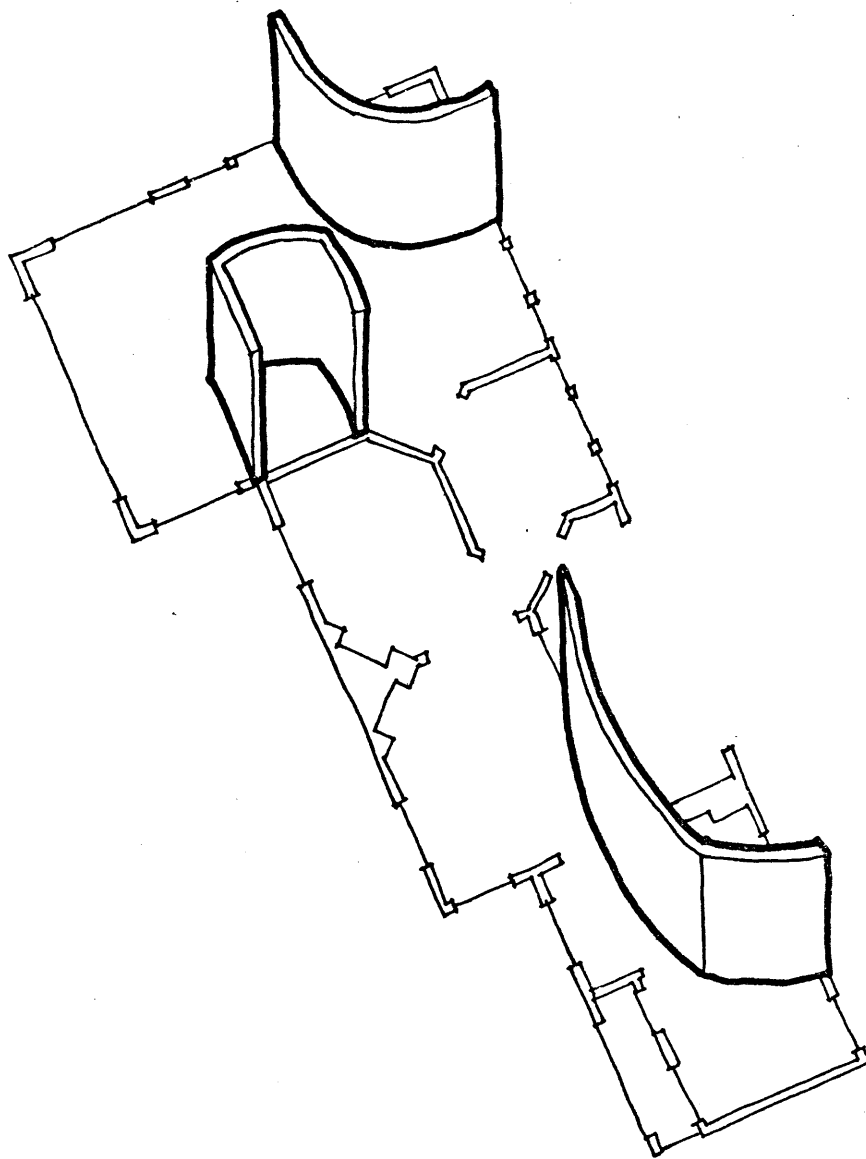

# Addition Prelude

Although the activities of renovation and addition both make use of the same realm of ideas, each stresses a different group from within that realm. With an intervention like the preceding renovation in which the exterior changes were relatively minor, there is little danger that the new forms will destroy the wholeness of the existing building. Rather, the new forms will in all likelihood be dominated by the old; the efforts of the designer thus focus on insuring that the new acknowledgements will be visible through the existing forms.

With addition, however, the opposite danger exists: by their very nature the new forms are likely to be so very visible that they will dominate the existing building and destroy its wholeness. The designer's concern thus shifts somewhat away from efforts at marking his interventions and focuses more on ways of integrating them with the existing forms. This integration is of two types, and they correspond to the two levels at which a designer works-- that is, the level of the overall strategy of composition and the level of the specific formal relations that carry out that strategy and make it manifest.

## INTEGRATION BY OVERALL STRATEGY

It has been my contention all along that the ineffable "feel" of a building is contained at least partly in the (observed) manner of its composition. If this is so then the goal of this first

level of integration would be to maintain that feeling in the existing building and extend it into the new additions by emulating the perceived strategies of composition. That is, if one apprehends a perceptual effect engendered by a formal relation and explains that relation as an acknowledgement of an aspect of the building situation--then, working backward, that formal relation can be seen as a part of an (observed) compositional strategy for acknowledging that building aspect. An example is the flat front facade of the original Browne house, a composition of forms that was "explained" as this house's particular way of acknowledging its SITE CONDITION of facing the inlet: by manifesting forms in an intervention that maintained and extended this enfronting condition, a new addition would be emulating the existing strategy of composition.

This type of emulation would be a way of responding to a situation in which a particular building aspect that existed at the time of the original building continued to exist in the time of the new intervention. But often the intervention itself will create new building aspects, in which case simple emulation of existing compositional strategies would be insufficient. In this situation, the analytical method might be used as a tool for innovation: the designer might discover emulatable compositional devices among the existing forms by postulating

relations-between-forms not conventionally seen (but reasonably "seeable"); he could then carry these relations into the new addition.

An example of this way of drawing solutions from an analysis of observed composition might be seen in Carlo Aymonino's project for replacing a building on the main square of the Italian town of Fano. Here the new building has not merely to front on the square as had the previous building, but has also to face the street entering the square at the corner (a street which the previous building had not acknowledged, treating it as no more than an expedient way of access). One might see the compositional strategy of this design as drawn from an innovative analysis of the continuous arcade that runs through all the existing buildings of the square: by viewing this arcade not as "a void behind a screen" but instead as "one plane behind another," one obtains a



new compositional device: it becomes possible to fold the outer plane to enfront both streets while bending the inner plane around behind to connect and integrate the two facades.

And analysis can aid innovation in another way: by viewing a particular compositional device as an acknowledgment of a certain condition, a designer might reuse that same device to address an analogous condition. As an example, the bent plane and splayed pier of the Fano buildings were seen as devices for simultaneously enfronting two streets: the following design for the Browne house will use both of these devices to address the analogous requirement for simultaneously enfronting the ocean and the hillside.

#### INTEGRATION BY FORMAL RELATIONS

But an addition to an existing building should be seen not only to acknowledge the original and new aspects of the building situation, but also to address the new condition of integration itself; the new forms ought to display a reasonable strategy of composition that could engender a perception of imagined continuity between old and new. (In most cases, this seen continuity will, of necessity, be only a conceptual one, since usually the "added-on" nature of the new forms is apparent simply by their physical attributes. What is desired is that this imagined continuity be plausible enough that it can stand

as an alternative perception.) The analysis of the Browne house showed how such a perception of integration was engendered through multiply-suggestive articulation--by implying so many division-points that each became viewable as a roughly-equivalent perception, and no one way-of-dividing could dominate one's image of the building. One could say, then, that this multiply-suggestive articulation is the observed strategy of composition by which the problem of formal integration is addressed in the particular case of the Percy Browne house. In the design that follows I thus try to emulate this strategy in my efforts at integrating the new addition with the existing house.

Specifically, there are (at least) four ways in which this particular strategy might be applied to the task of integration:

1. Make the articulated joint between old and new no less ignorable than the articulations between other parts of the building (both old and new). This might be done by playing down the old-new joint itself or, conversely, by playing up the others--emphasizing the existing articulations to the point that the new one no longer stands out (taking care, of course, that this emphasizing does not destroy the possibility of also perceiving the parts as joined to each other).
2. Bridge the gap with parts that overlay



the joint between old and new; that is, insert elements that can be seen as claimed by both old and new, much as in the renovation example the extended foot of the stairs could be seen as belonging to both rooms. Or, if no physical intervention is called for:

3. Articulate-out parts that consist of old and new: compose the forms so as to suggest lines-of-division on either side of the old-new joint so that, if one were to focus on those articulations, he would perceive a (conceptual) element that, like the stair, bridged the (physical) gap.
4. Finally, suggest formal relations that involve both old and new elements. Recalling the vase-and-profiles situation in which either of two forms could be seen as the base against which the other would appear a deviation, a similar relation can be set up in which a set of new forms is given the appearance of having a relation to a set of existing forms; this relation can be one in which the new forms look like deviations from the pattern suggested by the existing, or else (more interestingly) one in which the old forms seem a deviation from the pattern set up by the new forms.

The use of these four specific devices for integration--and the governing strategy of multiply-suggestive articulation--will be shown in the following design.

# Addition

As was true in the case of the renovation, the thesis nature of this design results in an inevitable tension between the demands of practical buildability and those of theory-demonstration. As is so often the case, the conflict cannot be resolved in favor of one side or the other, but must instead be balanced only by applying a standard of reasonableness. That is, the situation must be one in which the program requirements are chosen and the design solutions evolved neither solely for their potential applicability nor for their ability to illustrate ideas, but rather for their capacity simultaneously to pose and address certain interesting formal problems while still remaining plausible and possible buildable architecture.

Also as with the renovation, the project for an addition to the Browne house will assume present site conditions but will take as its base not the house as it now exists but the house as originally built. However, for the purposes of demonstration, I have chosen a program for the addition that differs radically from that for the renovation: the house is to be modified to accommodate a semi-retired couple whose children have left home (but who visit occasionally), who entertain frequently and lavishly (with the help of a live-in servant), but who require also the option of intimacy and privacy for their personal activities. Thus, the program implies the need for

both large, open spaces for entertaining and for smaller, more intimate spaces for daily living.

## Design strategy.

The solution for this basic requirement draws once more on the theme of reconceptualizing different imagined spaces out of the same actual space. Specifically, the design will try to suggest to the viewer a conceptual framework of two houses interlocked--one, which I will term the Great House, for entertaining, and another Little House for daily living, the two houses sharing actual space to the greatest extent possible. That the two houses cannot be completely coterminous is occasioned by the nature of the spaces they imply: as far as is feasible, the Great House should in actuality be a single, uninterrupted space--a container for general activity foremost, articulated for specific activities only secondarily; the Little House, on the other hand, would consist primarily of specific cellular spaces whose unity could only be secondary and conceptual. The design recognizes this condition and tries to suggest--through-form the specific kind of unity appropriate for each House. Thus, for the

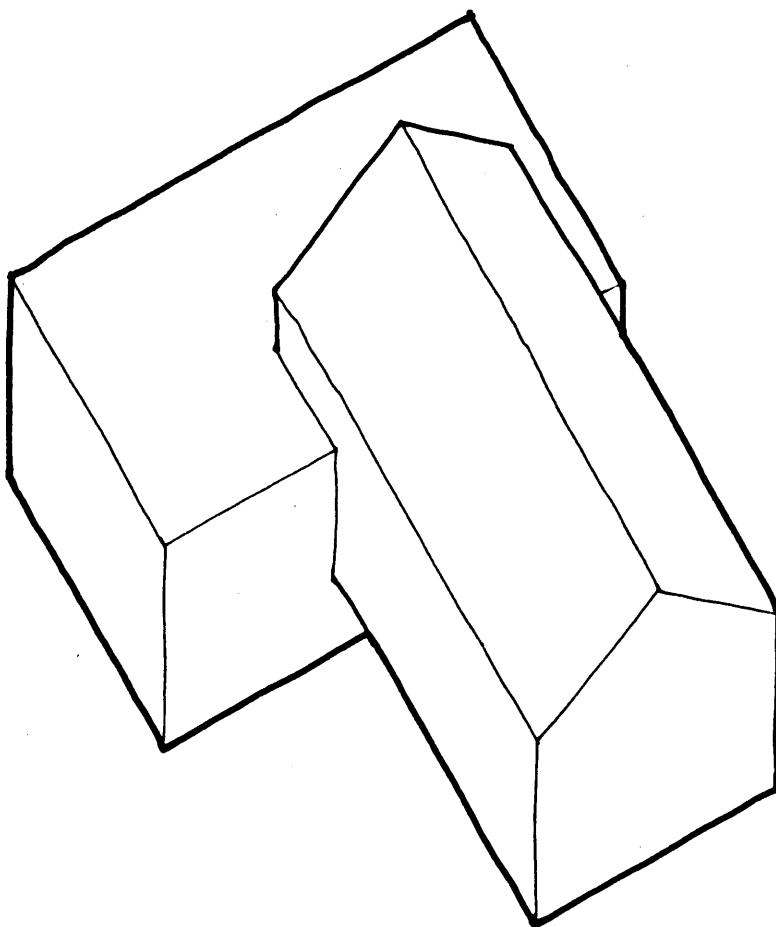

Great House, the design tries to imply the existence of a large space whose imagined total shape is simple and easily-graspable but whose actual configuration is one of richly-articulated possible spaces. For the Little House, the design tries to imply the existence of a clear, simple spiral armature of circulation off of which the cellular spaces hang. The design then tries to suggest the interlocking of these two conceptions by having the two Houses share certain crucial parts: first, some of the cellular spaces of the Little House are imagined spaces articulated out from the space of the Great House; and second, the Little House's armature of circulation--the conceptual spiral of movement on a staircase--is overlaid upon and intertwined with the stair that actually exists within the Great House.

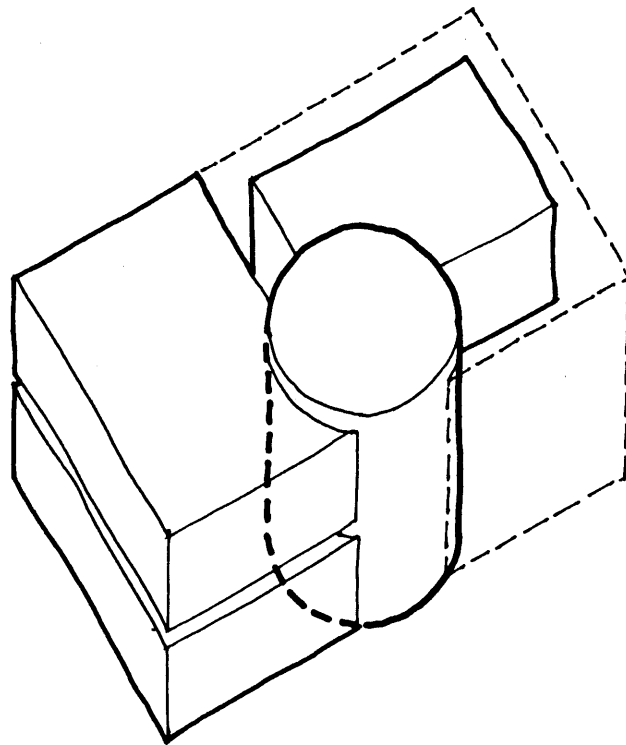
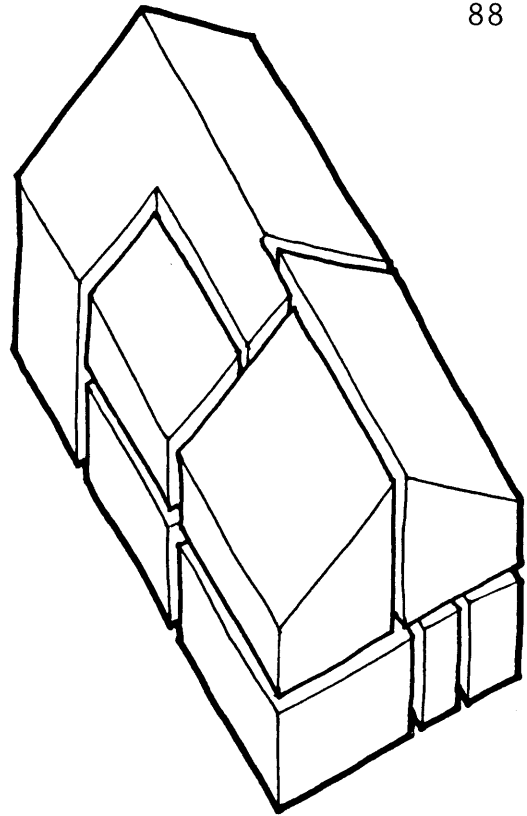

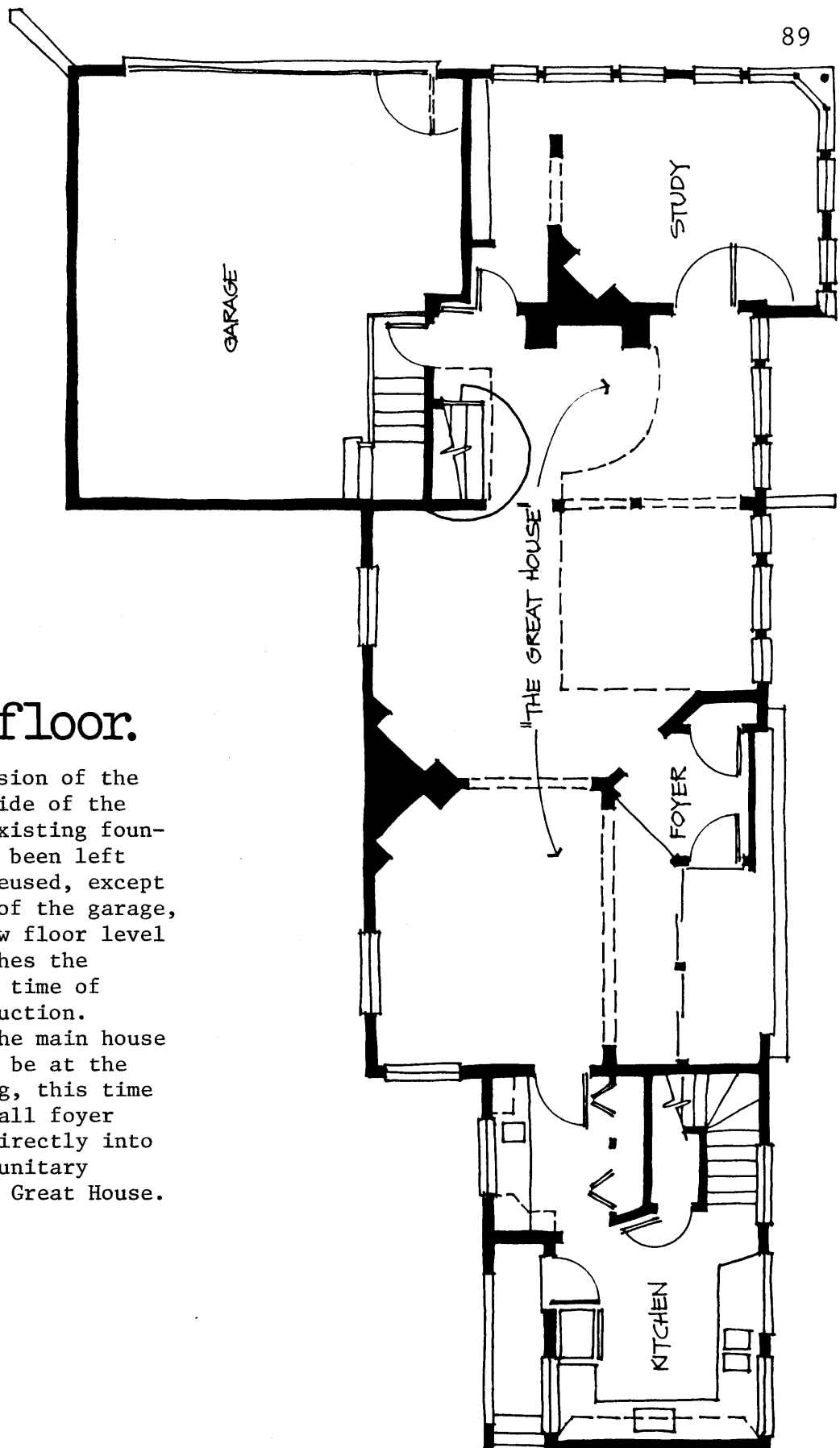

## First floor.

In the expansion of the right-hand side of the house, the existing foundations have been left intact and reused, except in the area of the garage, where the new floor level roughly matches the grade at the time of first construction. Entry into the main house continues to be at the porch opening, this time through a small foyer that opens directly into the implied unitary space of the Great House.

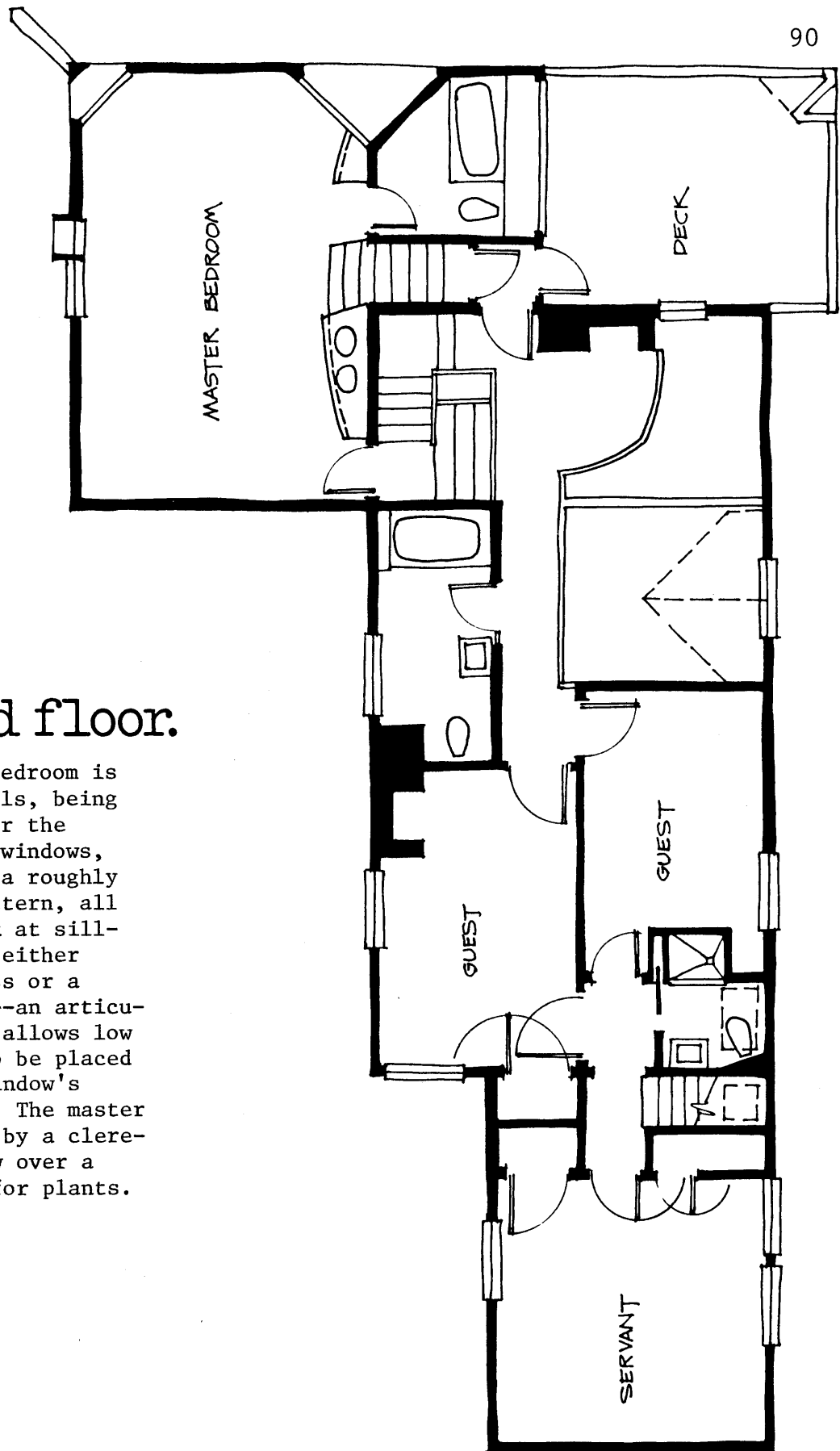

## Second floor.

The master bedroom is between levels, being directly over the garage; its windows, arranged in a roughly bi-axial pattern, all have a break at sill-height with either obscure glass or a panel below--an articulation that allows low furniture to be placed over each window's lower part. The master bath is lit by a clerestory window over a wide shelf for plants.

# Views.

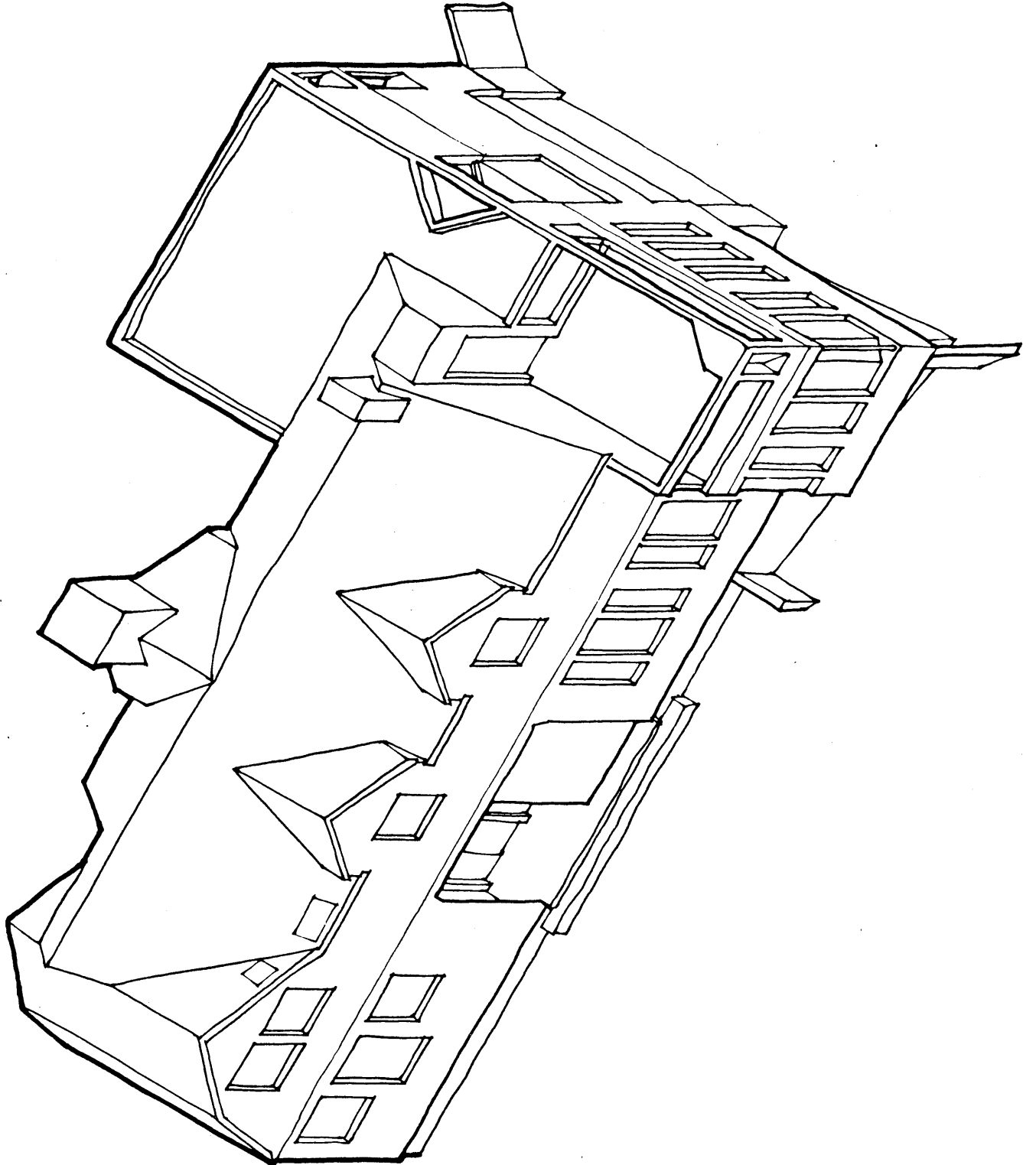

Note that, as with the renovation sketches, these views are somewhat schematized-- as for example with the windows, which are shown here as blank recesses, but which are to be conventional double-hung sashes, multi-paned in the original house, and of a matching single-light size in the new.

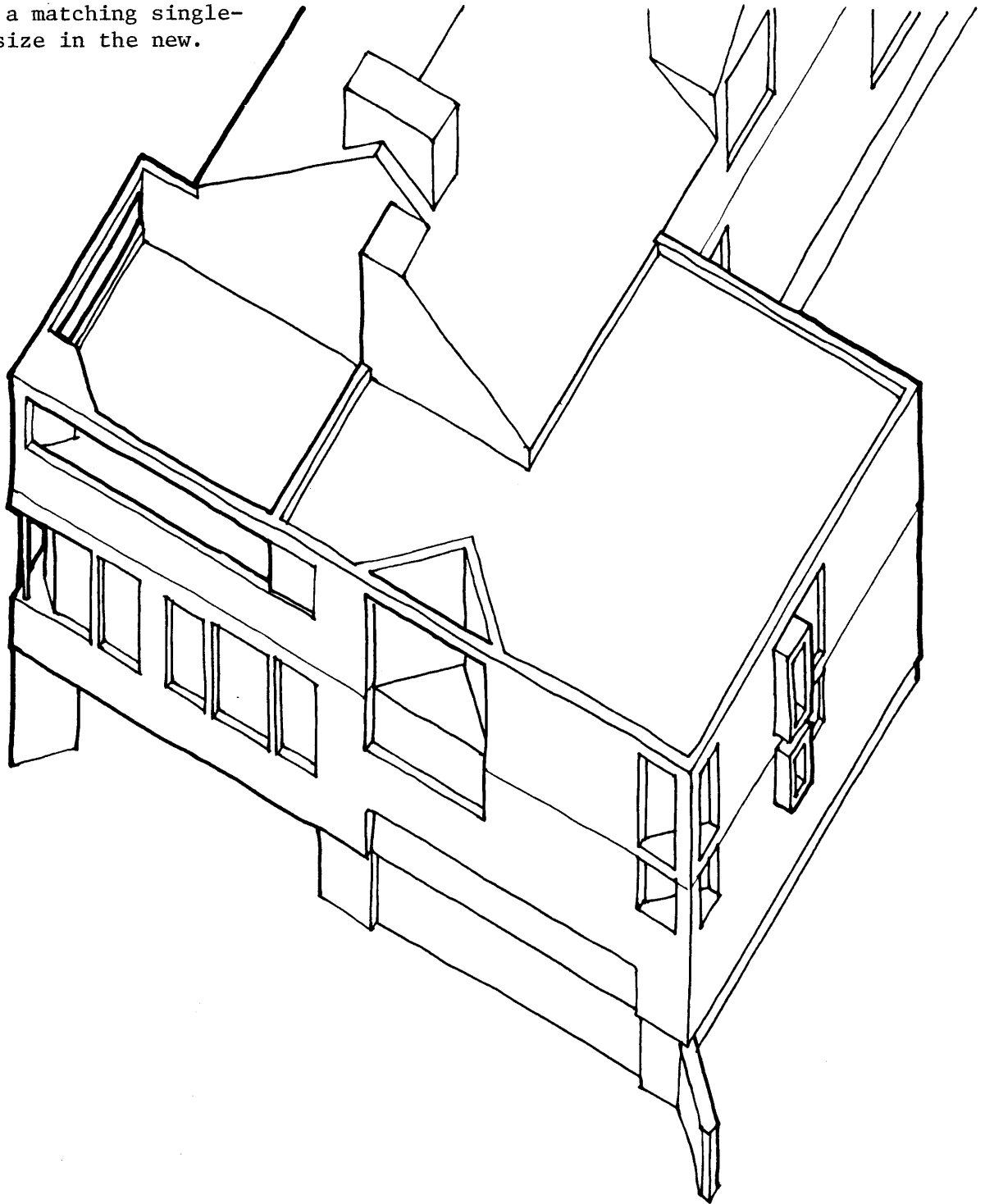



This cutaway shows more clearly the portions of the original walls that have been left to articulate the spaces and to give tell-tales of the previous conditions.

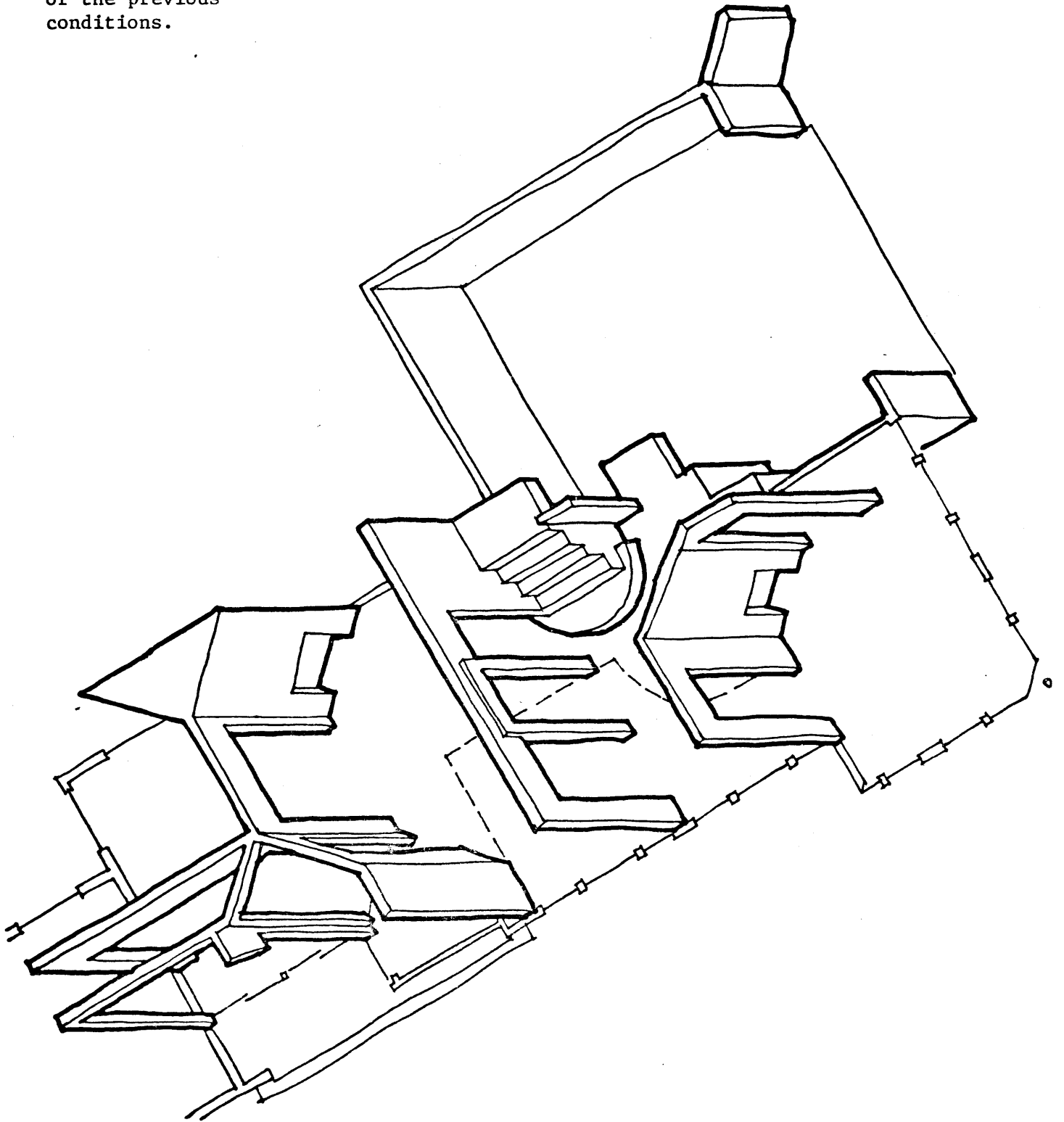

# Discussion of the design.

Before describing the specifics of the design, I should first clarify the field of intervention by defining what has not been changed from the original building. The servant's wing of the house, here looked upon as merely an appended piece of equipment, has been left basically intact, with only those changes required for efficient functioning: reorganizing the kitchen and pantry, rebuilding the stairs to code, inserting a new bath and closets in the maid's quarters--all done expediently and (as with the case of the outside stairs of the renovation) with no distortions to express intentionality. Thus the bath and new stairs, although inserted in much the same way as in the renovation, here merely receive new skylights and the windows are left as they were.

Since (due to the low ceilings of the existing bedrooms) the master bedroom is to be located in the new wing, one of the bedrooms is rendered superfluous. Exploiting this opportunity, the floor of the front right-hand bedroom has been removed, revealing to the viewer

the shape of the underside of the roof. This move achieves two goals: it suggests the total shape of an imaginable Great House, and it encloses the original spiral of the stair fully within this space. In other terms, by exposing the simple roof shape, enough of the total form is revealed that one can reasonably view the stair and the bedrooms, bath, and (created) balcony as intrusions into a complete shape, and thus as (articulated) parts enclosed within a whole.

At the same time, in keeping with the concept of building-as-palimpsest, I want to maintain the possibility simultaneously of experiencing the building as it was before the modifications. Thus in the dining area, the wall which held the former band of windows is removed only up to the 6'-6" door-head height, and likewise with the short piece of wall next to the main stair. As for the removed ceilings: in the former parlor, the ceiling was plain white plaster, and thus would have engendered a spatial experience essentially similar to that of the original dining room; but the former hall had a dark beamed ceiling that would have been a major factor in the space-experience and would have focused attention on the

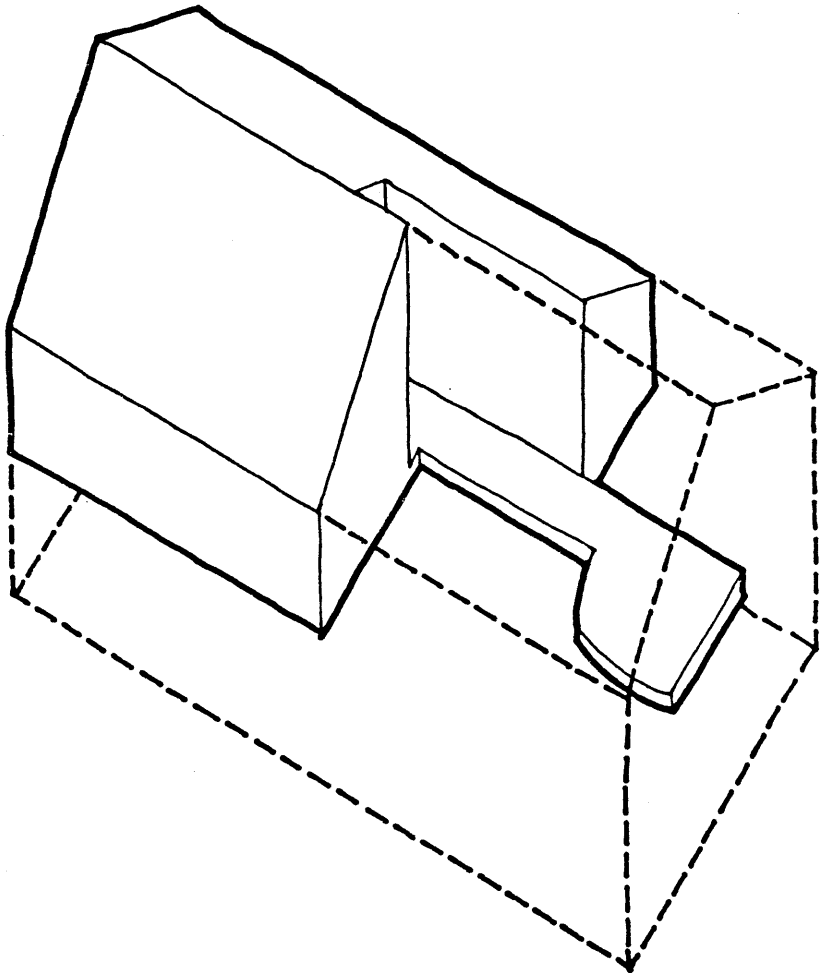
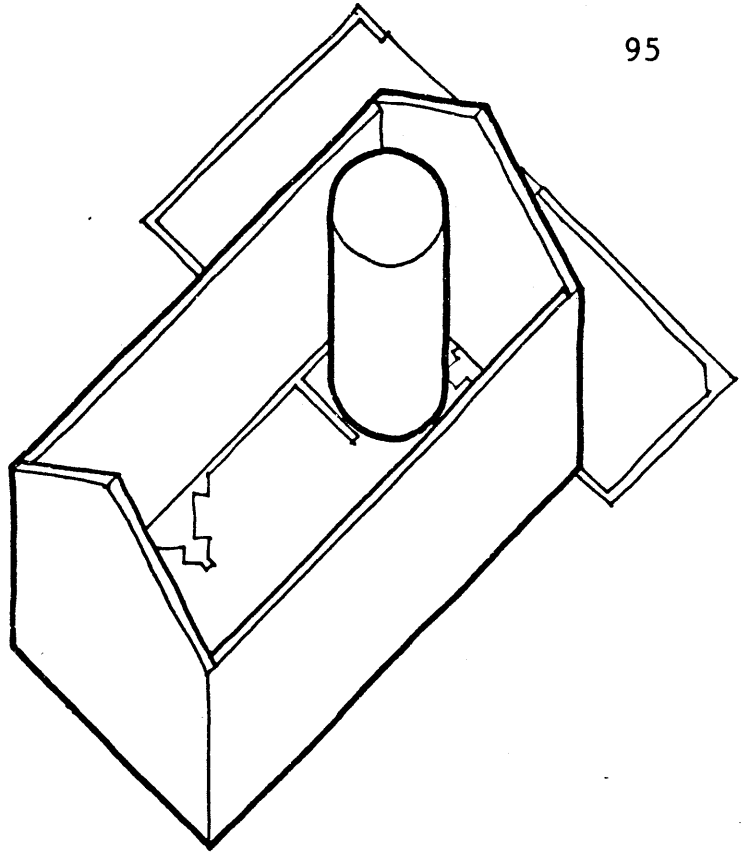

fireplace; a sizable portion of this ceiling has thus been retained around the fireplace in an attempt to maintain the possibility of huddling around a fire in a low, cozy nook. As for the original pastor's study, its configuration and dimensions (8 by 10, minus the fireplace and doors) practically limited its contents to a desk and single lounge chair--quite sufficient for the needs of the Rev. Browne, but inadequate for the library/den/office of an executive still somewhat engaged in business. Thus, if the space were maintained as built, the required study would have to be elsewhere, and this room would become only an additional (albeit pleasant) fireplace nook. So, to maintain a linkage of space and use analogous to that of the original situation, two of the room's walls have been pushed out, but two have been kept so that the room's original extent is hinted at, and attention still focuses on the fireplace.

Now, entry into the (imagined) volume of the Great House, like entry into the shared foyer of the renovation, involves a tension between the ideal conceptual penetration of the form and the expedient path of actual movement. Entry into an actual great, simple space such as is here implied would

occur most naturally upon the centerline: to suggest this centerline entry as a base condition, a box is given the look of having shifted off-center into the porch void. Upon entering this vestibule (via a stuttered movement) and closing the door, the now-closed and symmetrical "U" suggests the (natural) straight-in entry one might expect. But again, the path of movement is directed elsewhere--thus the actual opening through which one enters focuses one's attention (as in the renovation) upon the staircase, whose bottom step again inflects in acknowledgement of this approach.

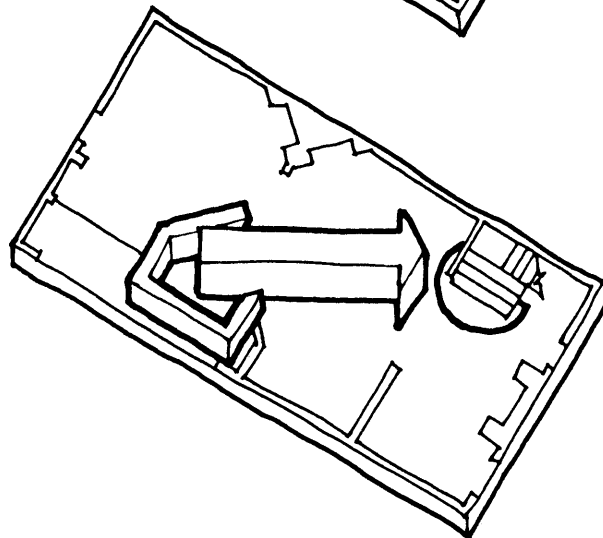
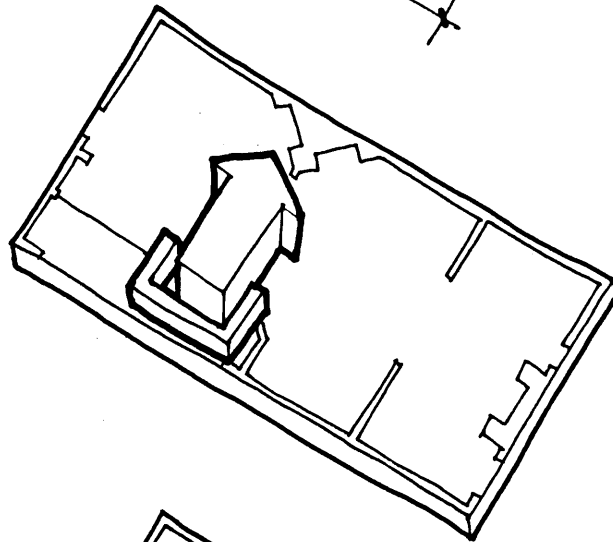
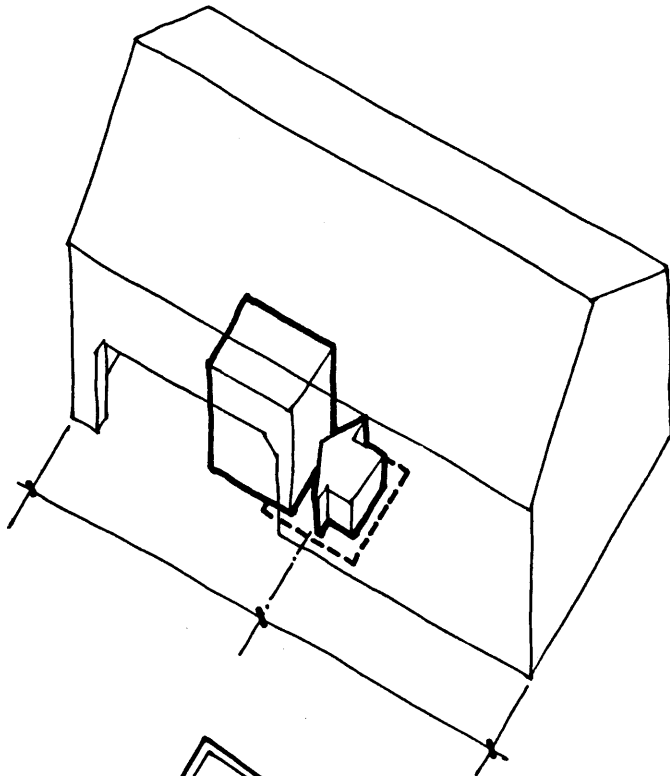

Now, there is an additional dividend from the efforts, mentioned above, to retain as much of the original house as possible for its value as palimpsest: by leaving implications of all its former divisions, the Great House is provided with a rich variety of articulated parts. From among these sub-spaces the couple could choose those they required for their private activities--two likely choices being the low-ceilinged space between the stairs and fireplace for a living-room area (that would additionally recreate the relationship of the two basic elements of a Victorian living hall), and the extension into the porch for a dining nook (that would face east for morning sun and allow the possibility of opening the sliding glass doors in warm weather).

But whichever spaces were chosen (and, of course, ideally all of the potential spaces would be chosen for some activity at one time or another), the design intention here is twofold: first, that these imagined spaces be viewable as, in a sense, equivalent to the actual defined rooms that make up the rest of the Little House, this relation being made concrete by their common connection to the spiral of circulation; and second, that this spiral of (real and

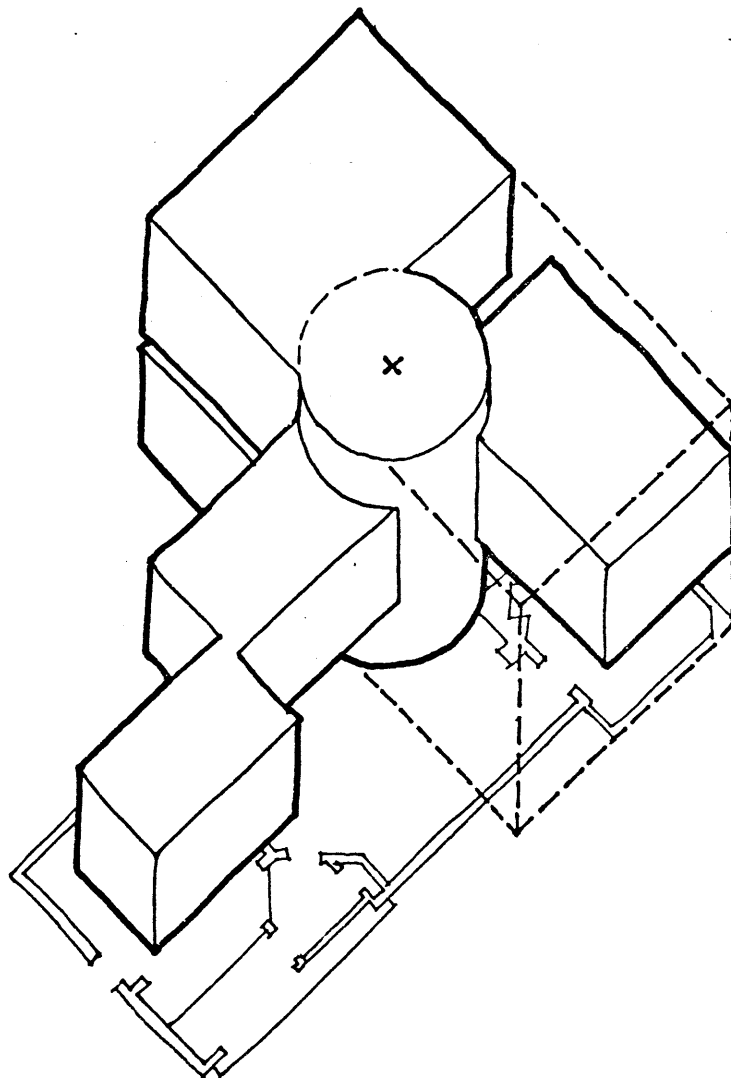

imagined) Little-House spaces and the space of the Great House be viewable as integrated into a combinatory whole--this relation being suggested by the overlapping and intertwining of their respective circulation armatures.

The spiral of movement of the Little House begins at the garage--the space that would be the primary entry for the family and its cars (a new relation acknowledged by treating the garage-door opening in a manner similar to that of the front-porch entry for guests, but seen primarily as an acknowledgement of automobile entry: the small pilot door for entry on foot is merely expediently cut into the garage door and not distorted to acknowledge a major pedestrian movement). Moving up the spiral, the door to the study opens directly onto the landing; here the original Richardson-width four-foot door has been kept, but new demands allow only the now-conventional 32 inches of it to open, and upon entry one must immediately

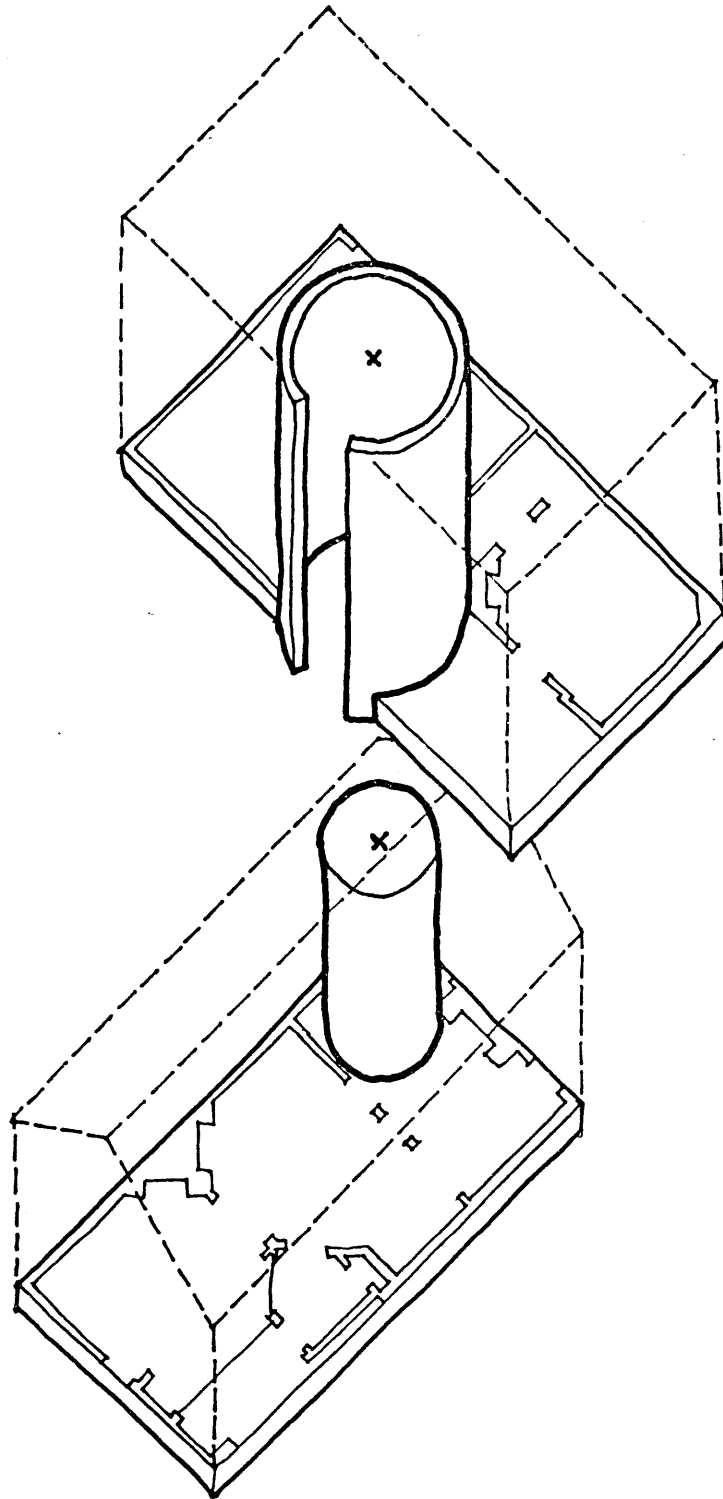

jog to the right. This combination of moves might suggest the (desired, natural) base relation in which the study would open directly onto the landing through the total four-foot opening, but which connection has been bumped forward in recognition of the pressure from the garage through which one has just passed.

The spiral continues on and joins the spiral of the Great House, the pattern of movement around the newel post echoed in the shape of the suspended fireplace nook above. The two spirals together ascend to the first landing (raising the possible reading of the extra width as an acknowledgement of doubled circulation) where they come untwined, the private circuit outside but concentric with the public.

The Great House armature then proceeds up and around to the balcony (suggesting that the shape of the fireplace nook could be explained as stretched by the now-released spiral vector) where it

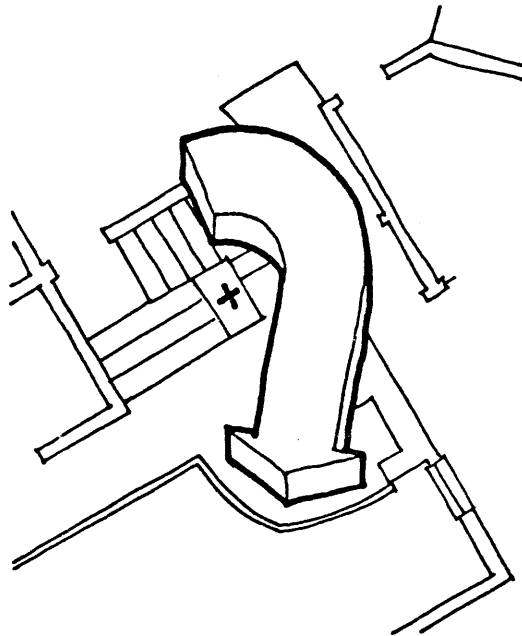
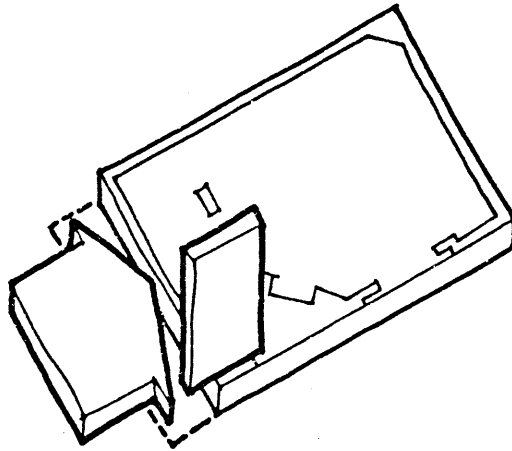



connects (literally and conceptually) the bath and the two guest rooms--all of whose openings look back into the double-height volume that suggests the limits and shape of the space with which they are (conceptually but not actually) coterminous.

The Little House spiral moves from the same landing and goes through the master bedroom where the stair leading up to the deck can be seen as inflected to one side in acknowledgement of the spiral path. The path finally ends at the roof deck (whose height gives one a greater view of the inlet than is possible from the front porch), where the space of the deck itself extends outward, stretched (in a reading suggested by the railing's connection to the main house) in response to the force of the movement vector.

Inside the bedroom a wedge has been opened up to provide morning sun at the dressing table and a view of the ocean, but the intentional distorting of this programmatic accommodation suggests other readings. If the window is seen as a continuation of

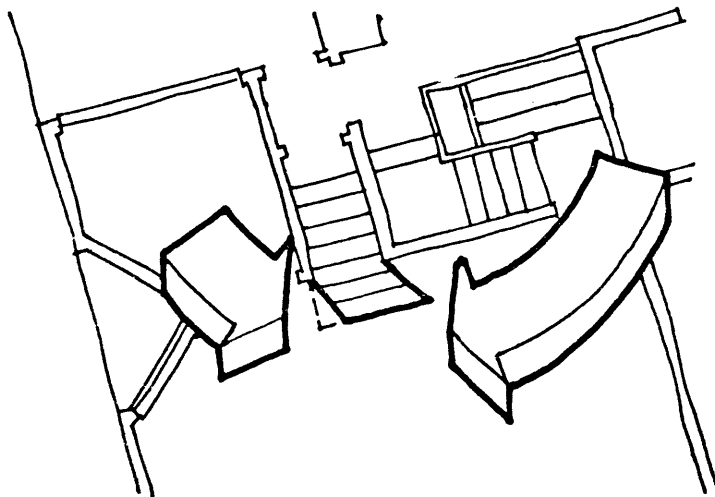
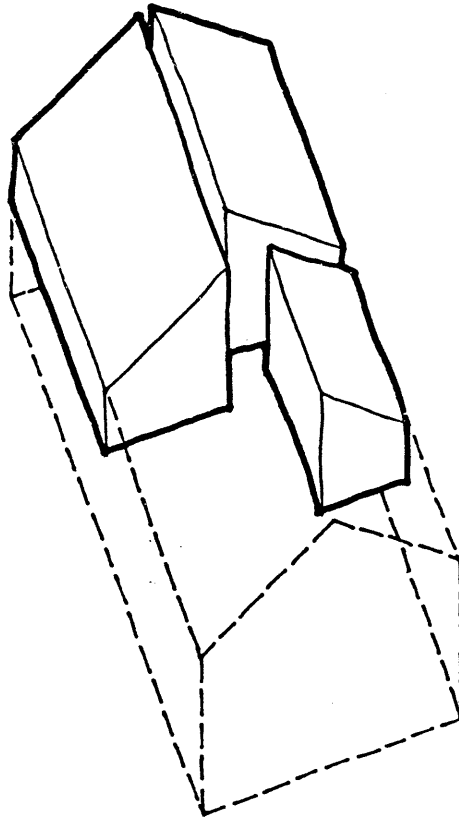

the mirror that extends across the front of the room, the "unnatural" off-center placement of the deck stair is given a rationale by an imagined base condition in which the mirror split at its centerline and half of it moved left, allowing the stair to cascade down and spill out through the resulting opening, a spilling suggested by the fact that the curved dresser assembly sits on the extended first riser of the stair. (The configuration also gives the necessarily-narrow stair a grander scale, more reflective of the space to which it leads, as in the stair in the Lautentian library vestibule.)

The shape of the arc further suggests the original (pre-wedge) width of the room. But even more, the dresser and the continuous mirror above it figure in a bridge-the-gap strategy like that of the left-hand stair in the renovation study. Since a large master bedroom like this one will naturally contain areas for (at minimum) sleeping, lounging, and dressing, this articulation can be aided (and a functional requirement met) by providing eye-height wardrobes to be used like the closet-headboard shown earlier. The continuous arc of the dresser provides the reminder-of-the-whole that allows this cutting-

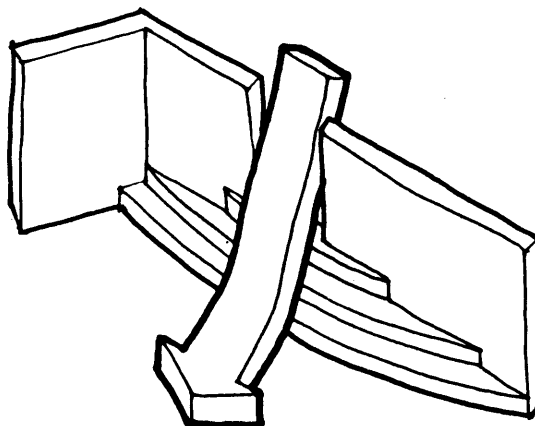
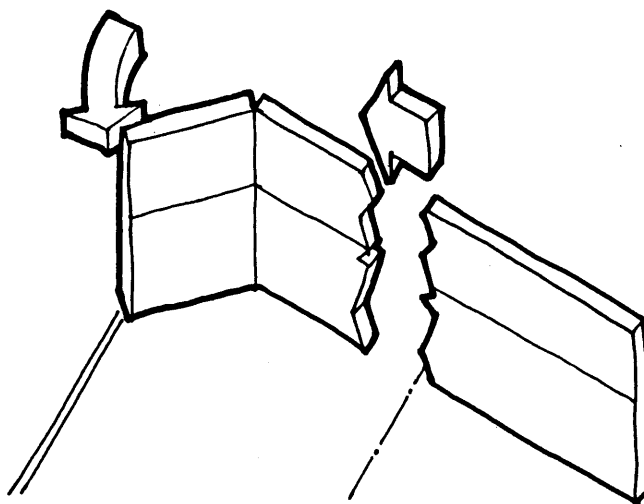
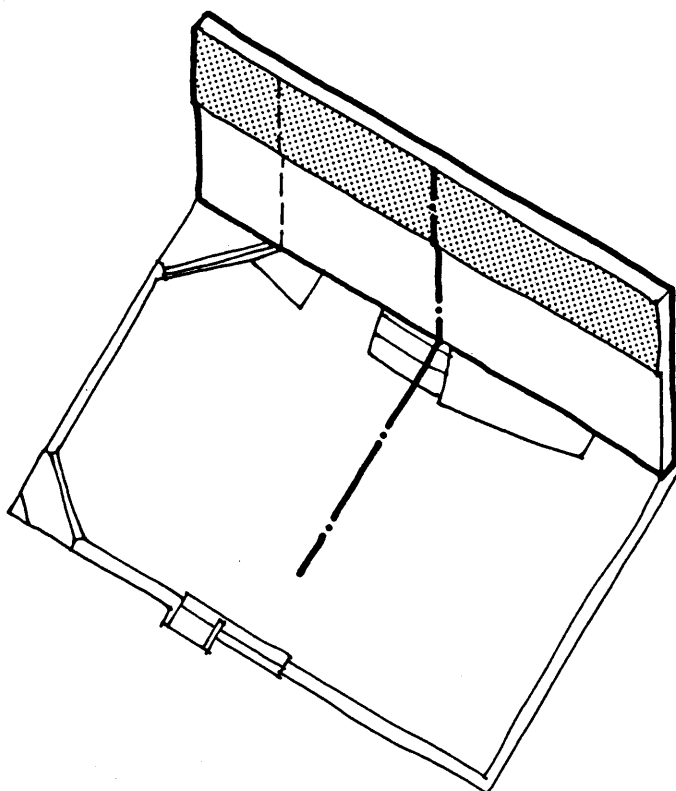

up process to proceed freely. Further, it tames the requirements of the equipment of vanity and sinks; that is, first, they can both be ignored because the arc serves as a container out of which they are mere articulations; and second, by being part of a continuous element, the placement of sinks and vanity does not determine the position of the wardrobes--that is, they need not be bunched together to form a defined dressing area, but can be spread apart at will, linked conceptually through the intermediary of the continuous arc of the dresser.

But all of the above has to do with the conceptual integration of volumes as experienced from the inside; there is the further problem of integrating the new additions with the existing house as seen from the outside (remembering also that these two modes of integration should, when seen with some subsuming understanding, reinforce each other). As suggested in the prelude to this section, one of the ways in which this design attempts this integration is by emulating, as far as is reasonable, the compositional strategy of multiply-suggestive articulation observed in the analysis of the original building. To accomplish this, the

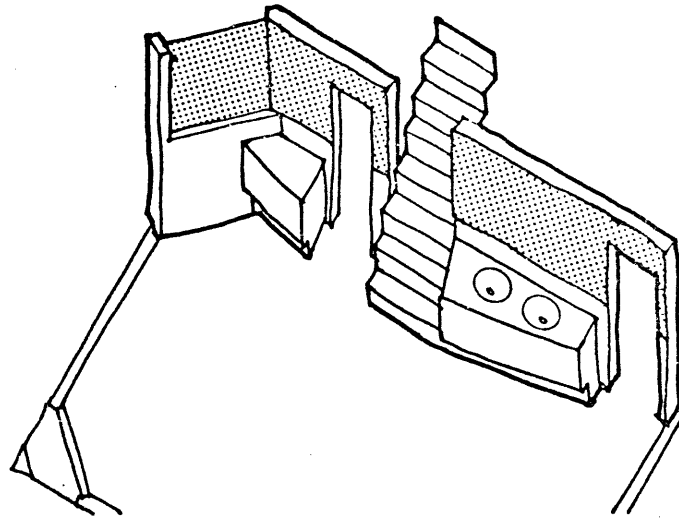

design attempts to manifest its forms in such a way that, by focusing attention on different aspects of the forms, a viewer could apprehend three different patterns of formal relations, each pattern internally consistent and each analyzable as an acknowledgement of a particular aspect of the building situation. More specifically, one set of formal relations tries to suggest that the new addition be seen as a complete, contained shape whose completeness points up the containedness and self-sufficiency of the pattern of PROGRAM requirements it houses (as the complete hip-roof cottage contained and acknowledged the complete pattern of the pastor's activities). A second set of formal relations then tries to suggest that the new addition be seen as a dependent shape, as only a part of a larger whole whose disposition can be seen as acknowledging SITE CONDITIONS (just as the walls of the pastor's cottage could be seen as dependent parts of the two flat facades that acknowledged both ocean and hillside). And finally, a third set of relations will try to suggest that the new addition be seen as a dependent part of an alternative whole--a whole which, in this case, can be seen as a dual resolution of both

MOVEMENT and FORMAL PREDISPOSITION (just as with the analysis of the original house's staircase: recall that the spiral of the stair marked-out a conceptual whole whose axis of symmetry reflected the vector of approach [MOVEMENT], and that the resolution of movement through the house in turn supplied a reasonable rationale for the stair's location [FORMAL PREDISPOSITION]).

#### THE ADDITION AS A COMPLETE SHAPE

By "complete shape" I do not mean the actual physical extent of the new addition: that shape would be apparent to any observer merely through the expedient tell-tales of its construction, no intentionality involved. Plus, its actual shape is merely the outcome of providing spaces for the individual parts of the program: it does not represent the kind of resolution of the program that subsumes the individual parts into a convincing, informing whole. In the case of the original house, the complete hip-roofed cottage was the whole shape that encompassed the public activities of the pastor. Here, a new complete shape is wanted as a similar conceptual container, in this case for the intimate activities of the owners.

The complete shape for this container is the almost paradigmatically-modern "shoebox"-- a shape (like the cottage) familiar enough that seeing a part of it would allow a viewer mentally to "complete" it and imagine the total form. This possibility of conceptually completing the form is important, because, if the conceptual shape could be conveyed only by revealing all of that shape, this completeness would prevent the necessary simultaneous perception that the form is an incomplete part of a greater whole. Thus, to suggest this condition of simultaneous wholeness and part-ness, the formal relation of interlocking that was seen in the original house is used; that is, the intention here is to suggest that the shoebox of the Little House be seen as both penetrating and being penetrated by the gable box of the Great House. The manner in which this relation is suggested emulates the condition observed in the original in which the two side-forms of barn and cottage appeared to overlap the center gable box when viewed from the rear but were themselves overlapped by the same gable box when observed from the front. With the shoebox, the suggestion of overlapping at the rear is simply an outcome of its physical disposition,

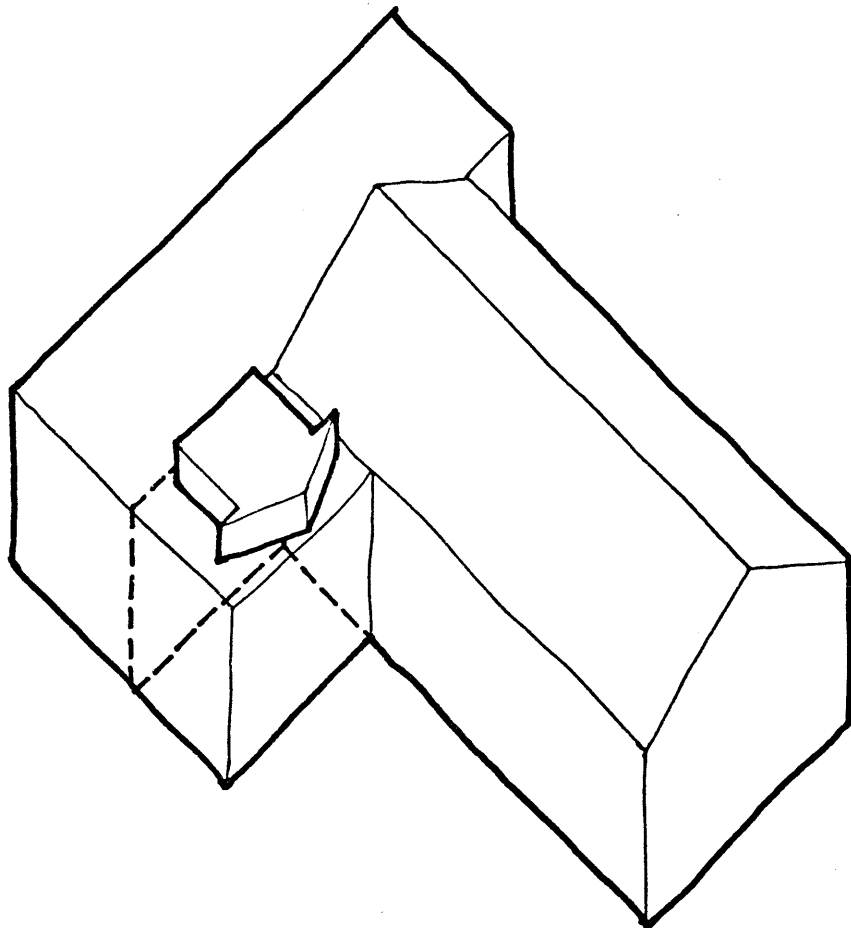

but to imply being overlapped in the front is more difficult, since the box extends beyond the face of the form that is to overlap it. But the same problem occurs at the rear of the original house where the barn must appear to overlap the gable box even though its face falls behind that of the larger form: the perception desired here is one in which the receded form penetrates half-way into the extended form, "erasing" half of that form as it moves; with the barn this perception is implied by, first, giving the overlapped gable-box form a look of "something missing" and then suggesting how much is missing by supplying a tell-tale of an imagined original extent. Here the pattern of windows gives a look of incompleteness; by attending to only those windows in the plane of the front of the box, one might discern the beginning of a base pattern of three pairs of windows--a perception that would be confirmed by restoring the (erased) box back to the edge of its imagined original extent marked by the new tell-tale retaining wall, the hypothetical twin of the pier supporting the opposite corner of the box. Further, by viewing the rear facade with this schema of the gable penetrating the shoebox, the simple physical overlapping

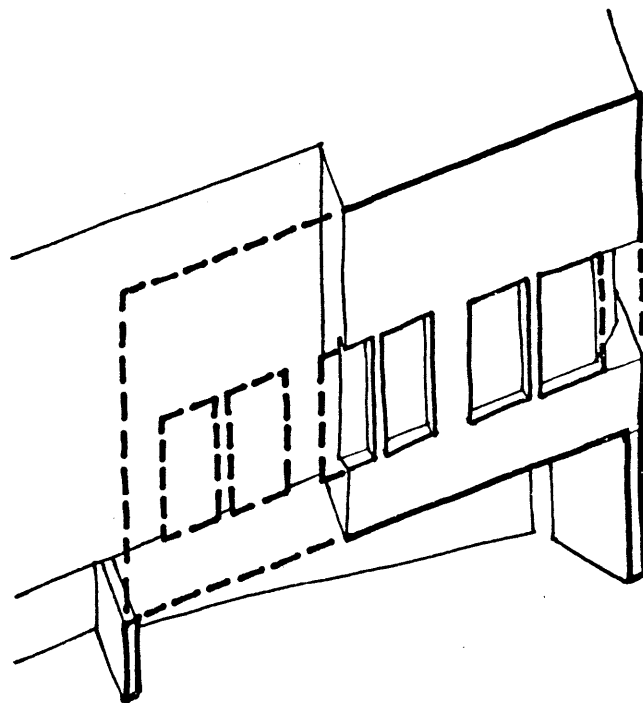
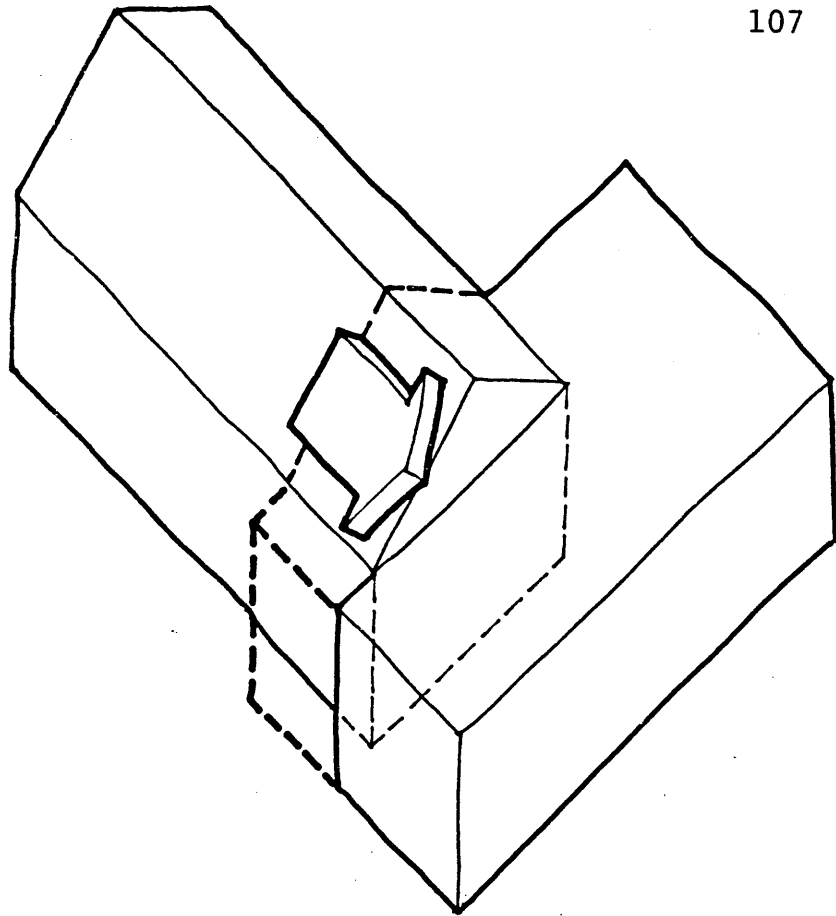

takes on another aspect: the boxed window at the middle of the facade (actually a shade against summer sunsets) can be seen as having moved to the left, off its natural centerline position, gouging out the surface as it passed--this in acknowledgement of the extension of the back slope of the gable (an extension made apparent by holding the peak of the new roof back from the ridge).

(As an aside, recall that the pastor's cottage showed another level of completeness in that the centering of the front window in the facade of the extension implied the imaginary existence of a complete form centered on the window as an axis. Likewise here, the suggestion of a complete form can be discerned in the I-shaped pattern formed by an imagined pairing of window-and-a-half's, the lateral extent of which is intentionally marked by the opening of the railing. In this case, this additional reading can be seen as a recognition of the original foundation--upon which the box sits and which aligns with the right-hand edge of the implied "I." This base form thus also contributes to the suggestion--used in another interpretation below--that the form of the box be seen as extended sideways, a perception reinforced

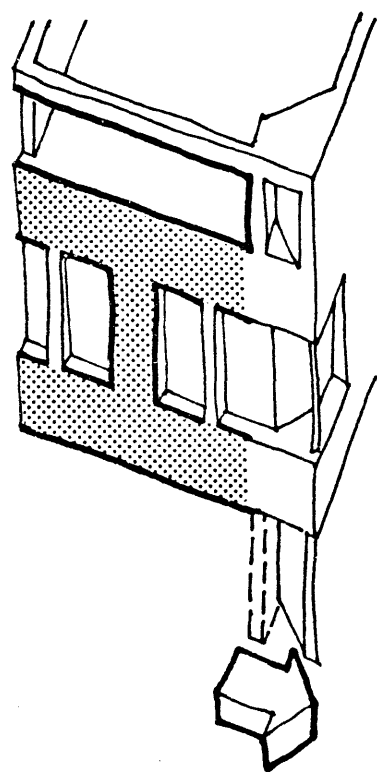
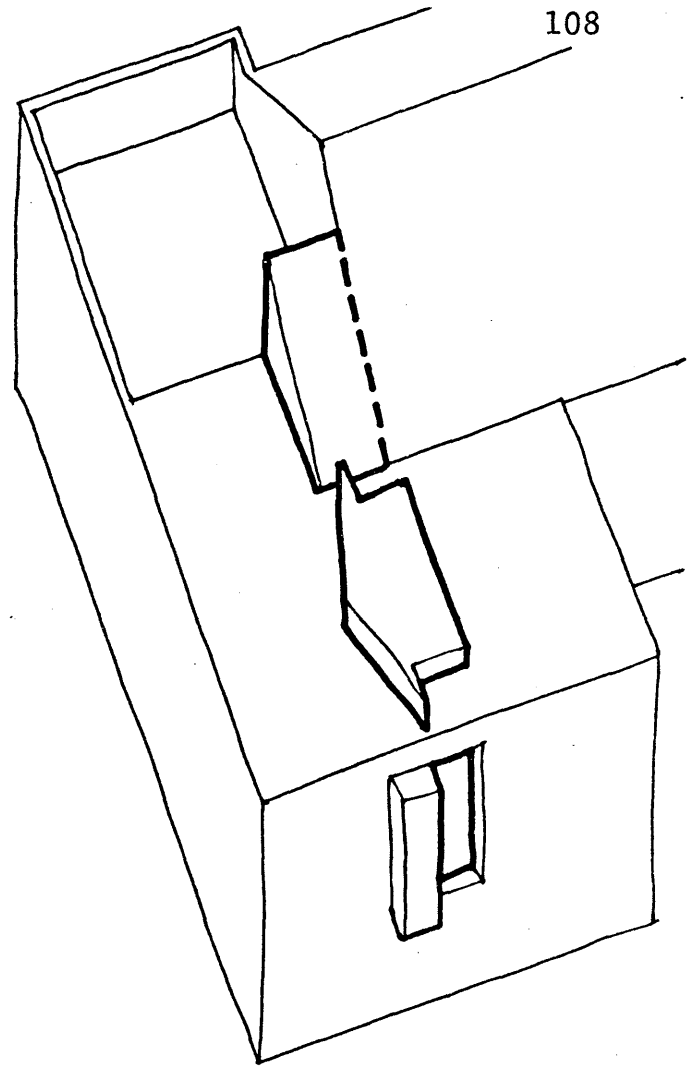



by the sideways twists of both the pier below and the rail-support above.)

#### THE ADDITION AS A PART OF A LARGER WHOLE

The second perception that I want to engender is that of a base condition in which the facades of the new addition are integral parts of an "L" of two planes that enfront the ocean and the hillside, in this way maintaining another of the observed compositional strategies of the original house.

Working against the maintenance of this perception is the fact that the front facade is no longer a continuous plane but is broken forward by the new addition. In order for the viewer to imagine a base condition in which the facade is again a flat plane, the facade of the addition must suggest that it has been displaced forward. This it does by suggesting that a break has occurred right across one of the windows (a displacement

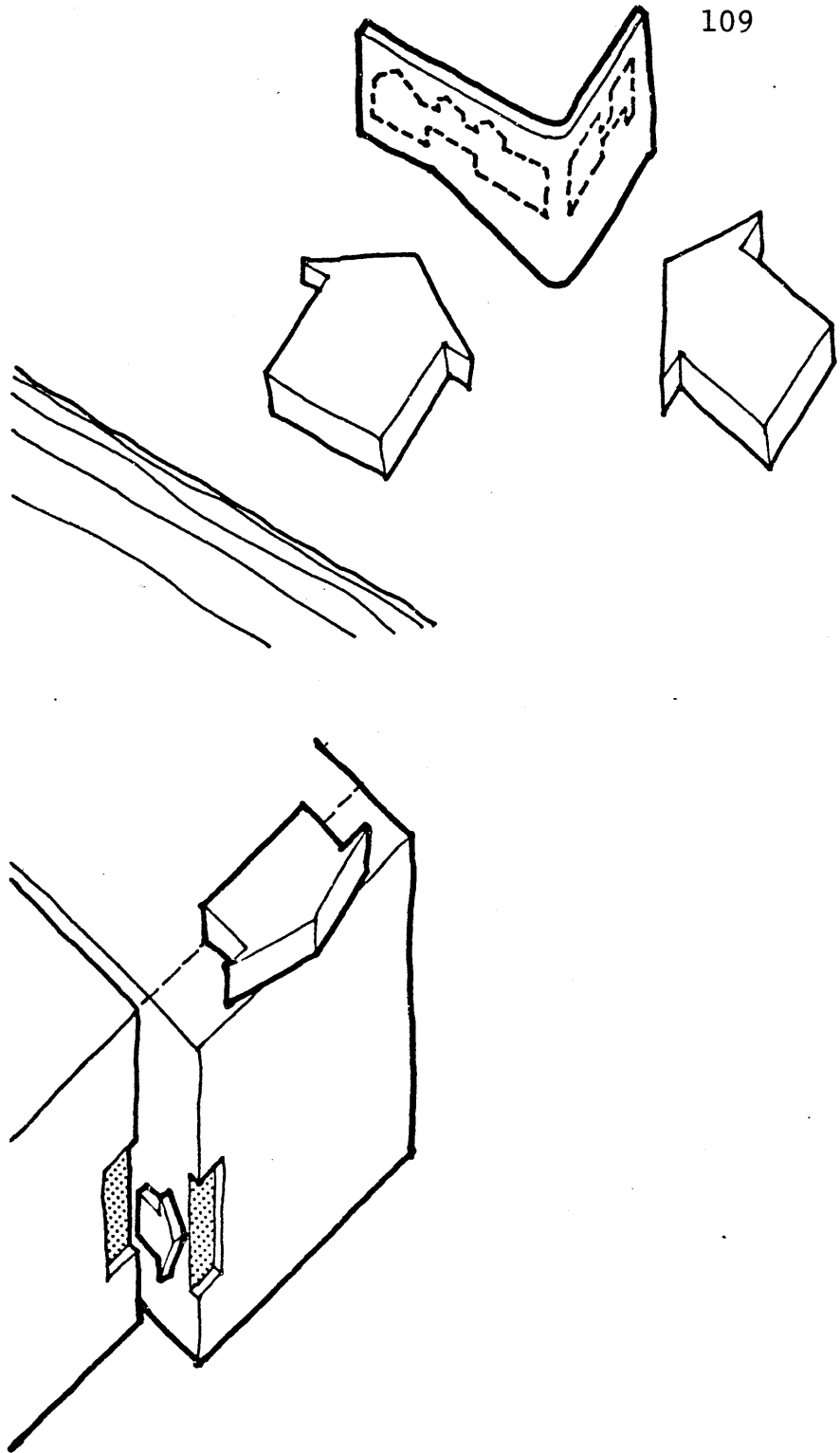

that is echoed in the side facade by the implied shift forward of the railing opening). By imaginatively pushing this piece of the facade back to its base position, the result is a continuous window rhythm (overlaid upon the original) that extends around the corner, linking the two facades. But by

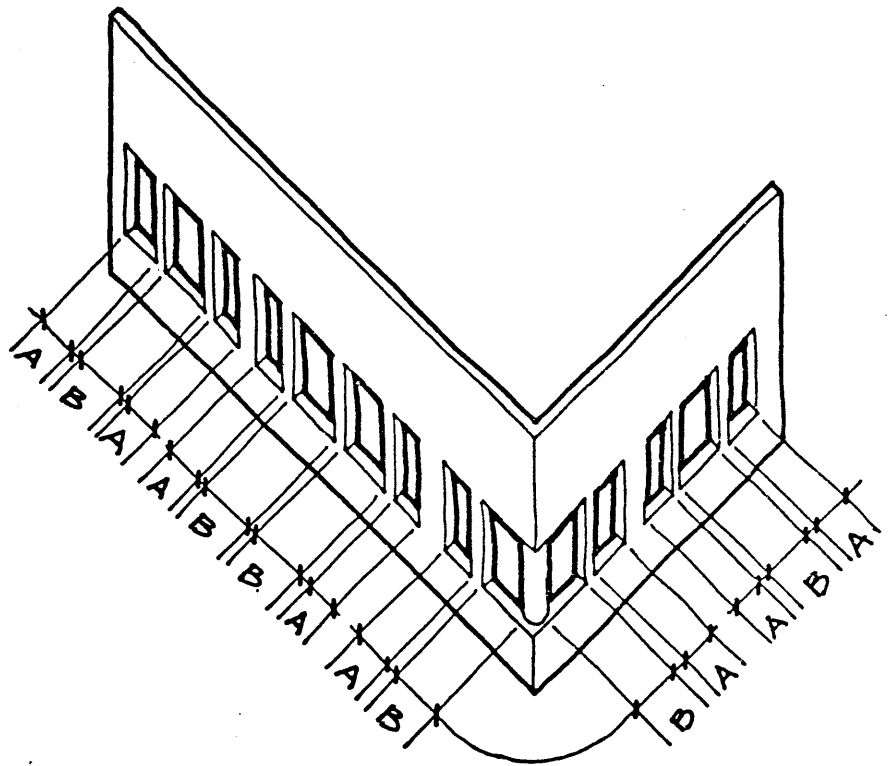
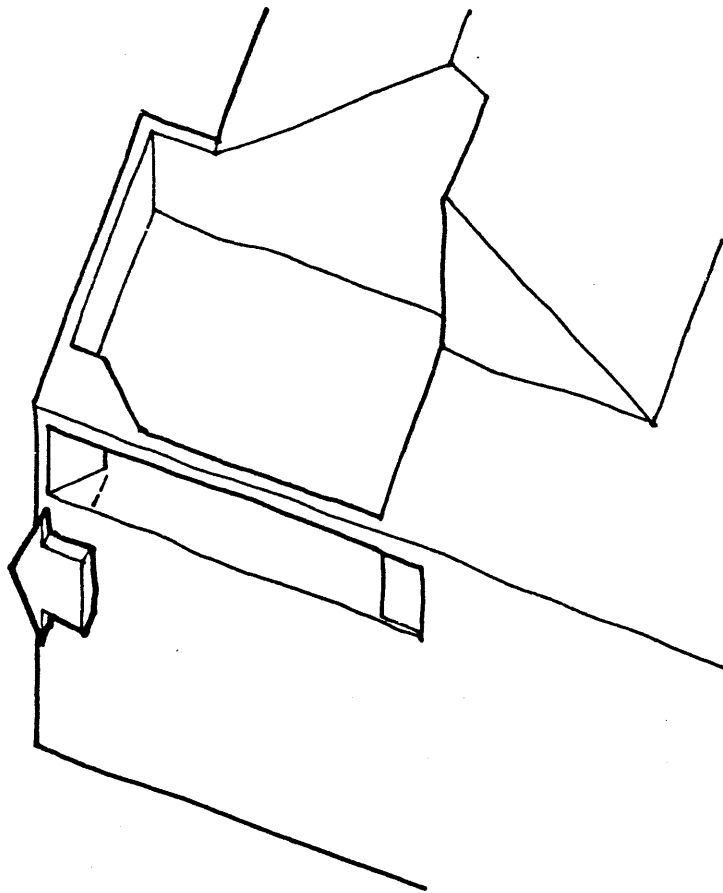

following the rhythm-pattern to its ends, one notices the two similarly-shaped voidings of the porch and the garage door--both only partly covered with a plane of diagonally-grooved plywood. By being only partly covered, both openings can be seen as shifted out of an original, fully-covered position: that is, the perception is engendered that, while the diagonal second skin has remained in place, the garage door has been pushed down and the porch opening displaced to the left. The impelling

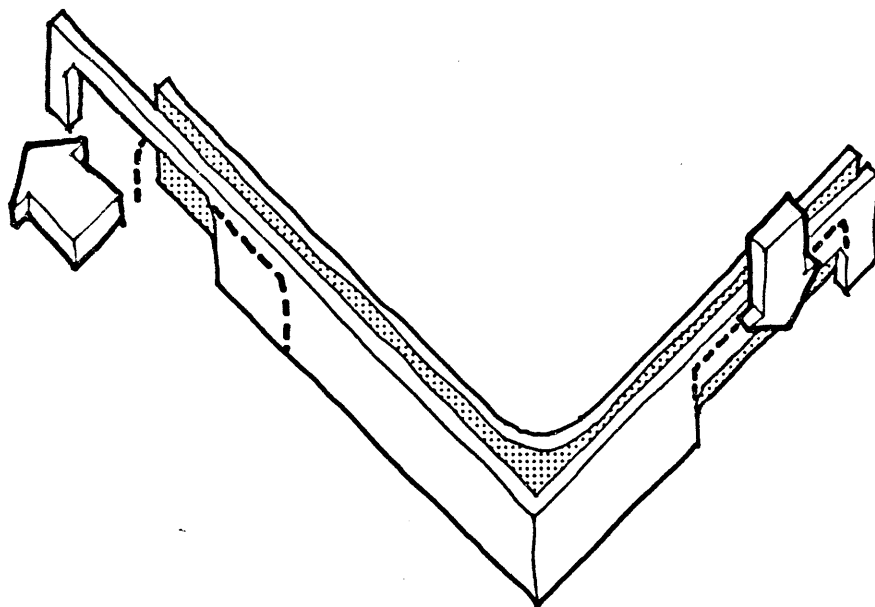

force for all this movement appears to be the wedge that has split open the side facade (a perception that is reinforced by the banded void that appears to have been shoved to the extreme right-hand corner--in actuality a diagonal window to balance the diagonal of the inside wedge-window). By its

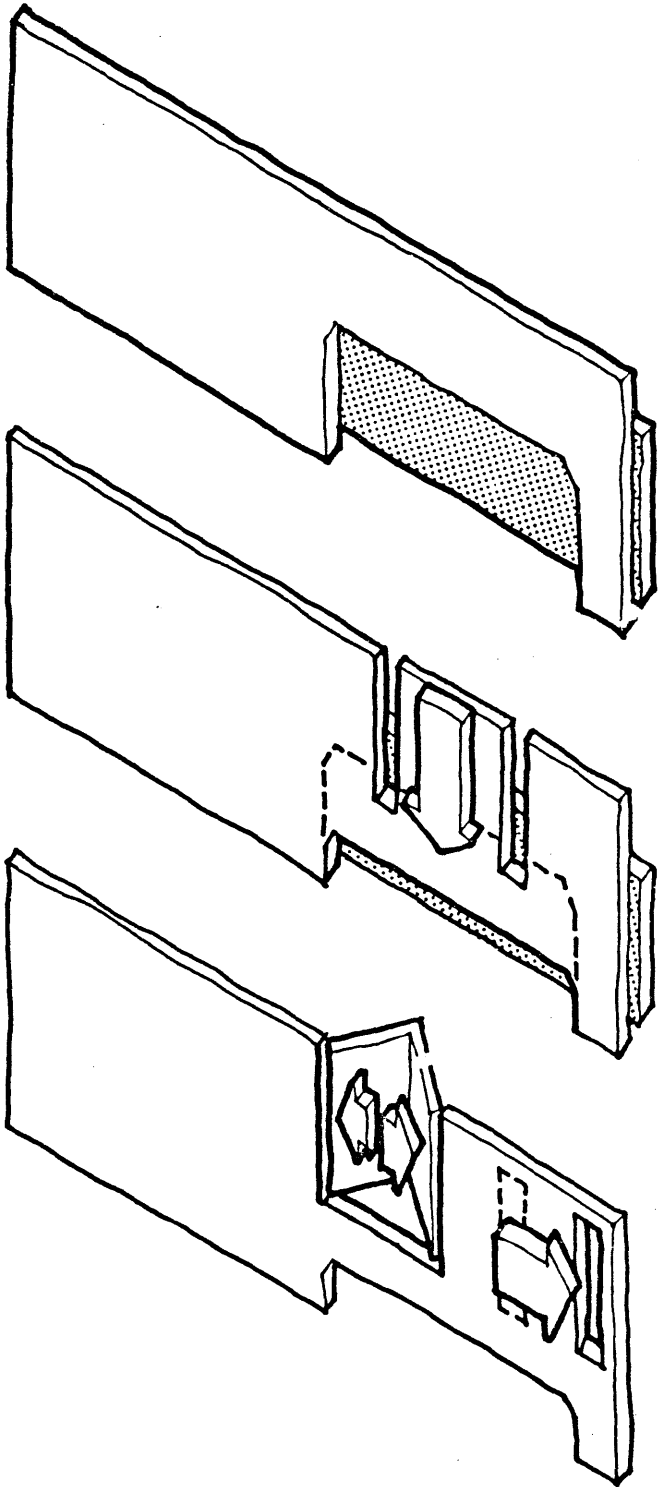

imagined driving-down and spreading-out, the wedge can be seen as having displaced around the corner a continuous band of openings (whose axis of symmetry would thus have been shifted from its natural position on the corner to its new place--the center of the above-noted I-shaped pattern--on the addition's front facade). This leftward shift-around-the-corner implies the continuity of the two facades in much the same manner as did the similar rightward movement of windows viewed in the original analysis. Further, note that these movements are suggested when the observer views the facades frontally--that is, when he places himself in the positions of the ocean and the hill slope, the two SITE CONDITIONS that these two linked facades acknowledge.

THE ADDITION AS A PART  
OF AN ALTERNATIVE WHOLE

But when viewed obliquely, different perceptions are suggested--perceptions that (if the above pattern holds) ought to be analyzable as acknowledgements of the likewise oblique vector of MOVEMENT toward the building. And further: in keeping with the ideal of multiple suggestiveness, the design ought to be such that the same elements that implied

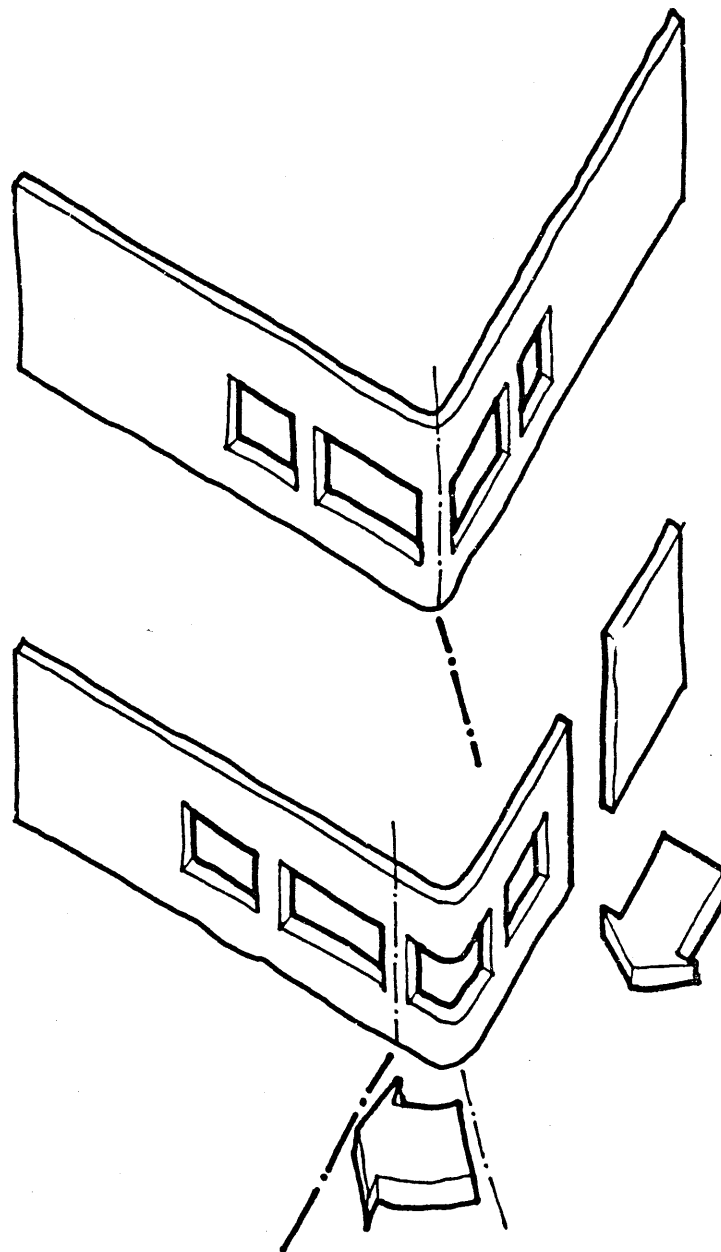

one set of perceptions to a frontal view will suggest an alternative set of perceptions to an oblique viewpoint. Thus when viewed from the northeast corner, the original foundation reads as a base from which is extended, toward the viewer, a form whose extent is indicated by the (open) corner of the addition and the front edge of the wedge. This perception of diagonal displacement is reinforced by the window pattern, which (by ignoring the pipe-support at the corner of the new addition) can be seen to have a continuous rhythm different from that observed in the frontal view. And the diagonal pier likewise gains an alternative interpretation, contributing to this perception of displacement.

Diagonal displacement is also suggested in the view of the addition from the northwest, where both the corner window and a short retaining wall orient toward the viewer. And once again the wedge figures in the perception, this time working in conjunction with the middle window of the back wall to suggest that the previously-mentioned movement of the split box be seen as a diagonal shift.

Now, if one imagines these two diagonal extensions as taking place simultaneously,

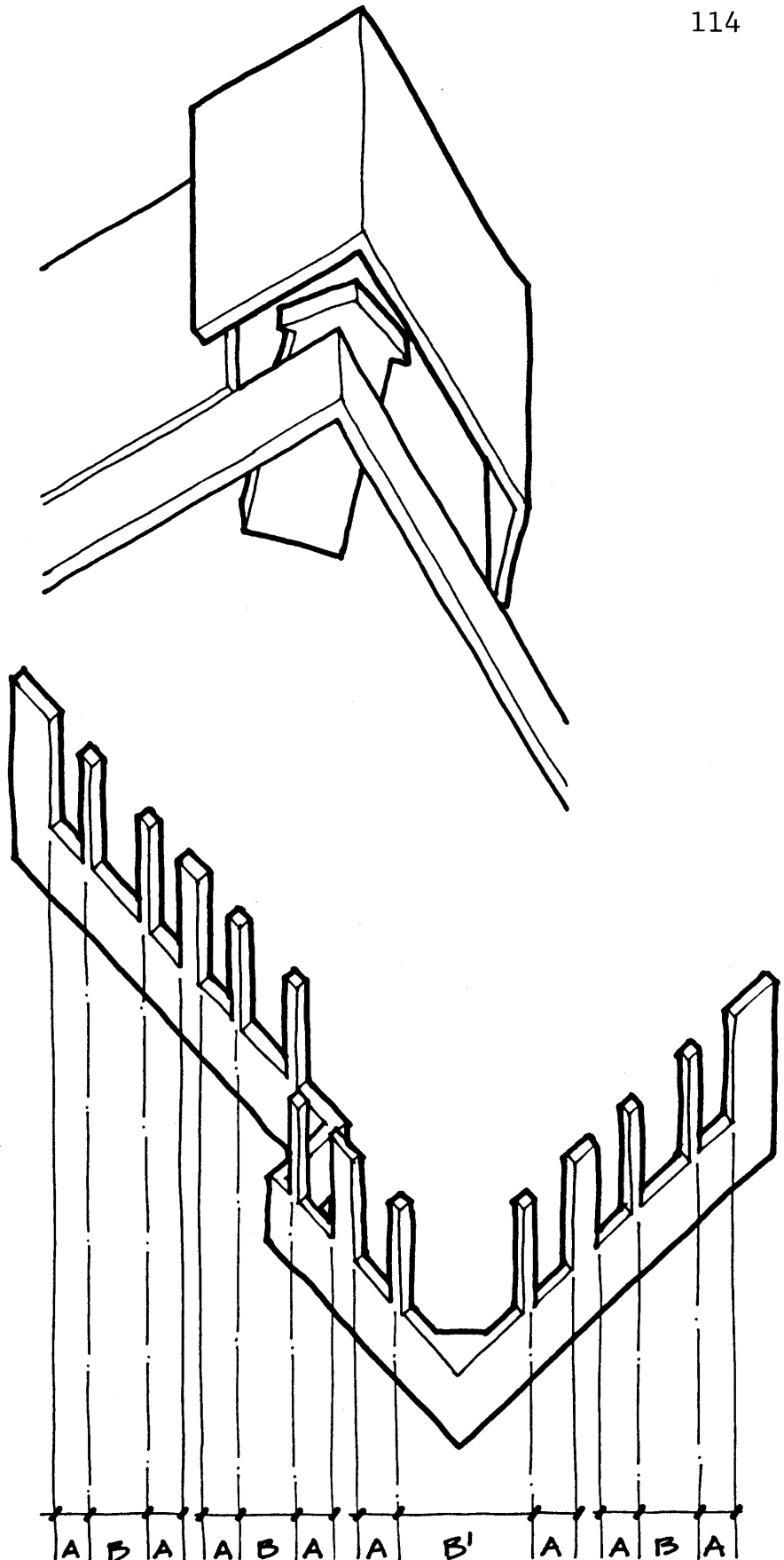

the resulting perception would be one in which the volume inside the shoebox form expands to the point where it cracks the skin and opens up a wedge into the volume. This double-diagonal expansion could be analyzed simply as a reflection of the increased volume of the new addition, but a more intriguing interpretation results when one recalls that, in the original house, oblique elements were tied into the house's orthogonal axis-system through their relation to the center of the conceptual cylinder of the main stair. And indeed, the two diagonal piers, the deck's rail-support, and the corner windows all do tie back to the stair. But one could also imagine that, by being encircled by a new overlaid spiral, the cylinder of the stair can itself be thought of as having expanded--and more, as having expanded in the direction of the "crack" at the wedge. Seen in this way, the stairway might be said to emulate the centralizing role of the stair in the pastor's cottage. That is, the condition of being pinned to the stair-cylinder allowed the spaces of the L-shaped visitors' realm to be pivoted into their final positions; the spaces of the Little House can likewise be seen as pinned to the stair-

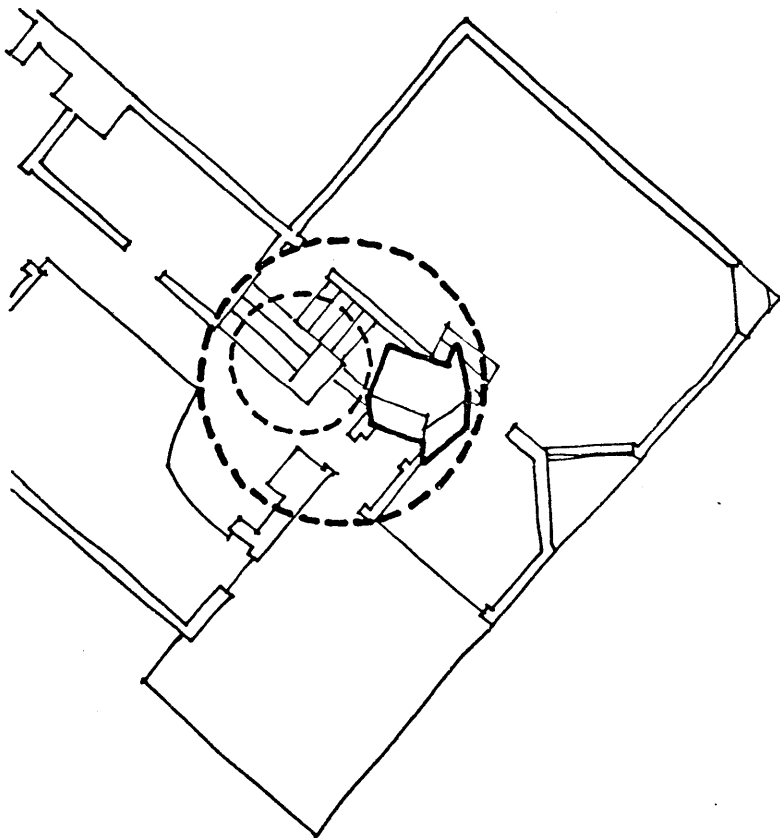
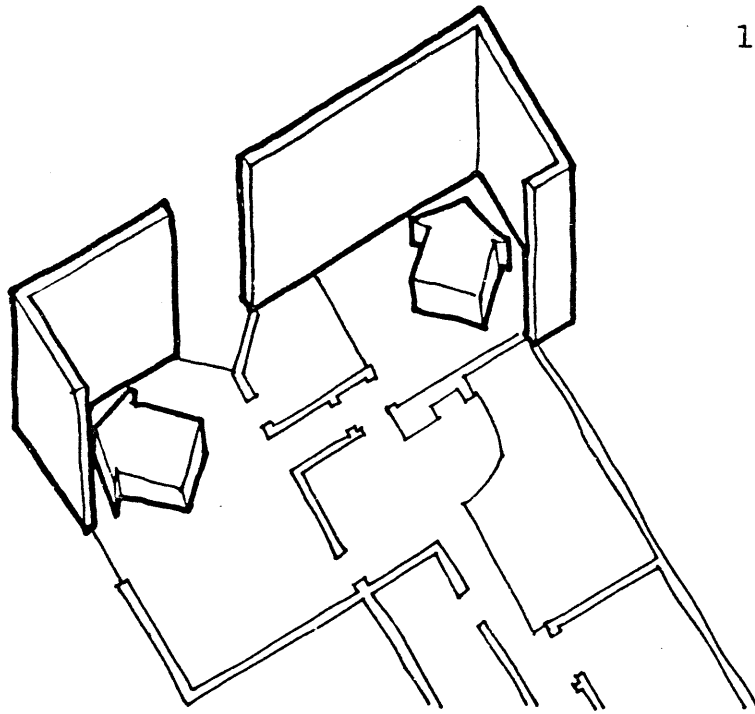

cylinder (a perception reinforced by one's actual movement), and because of this attachment they would naturally crack apart when that cylinder expanded.

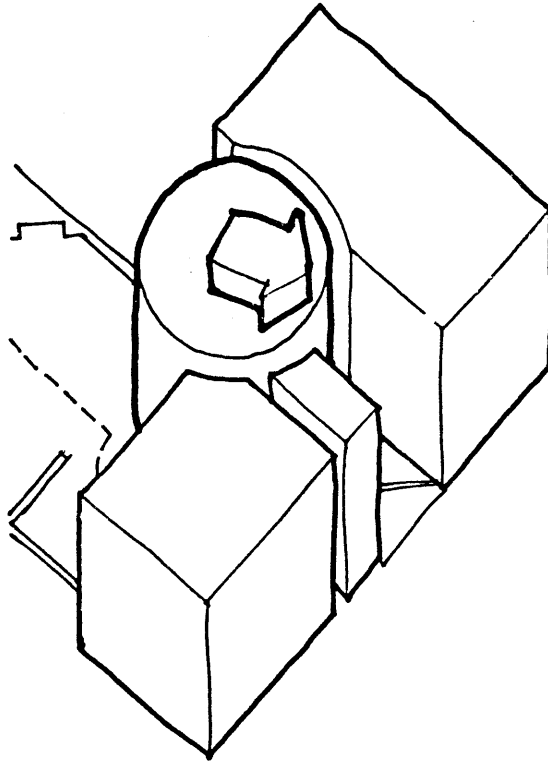
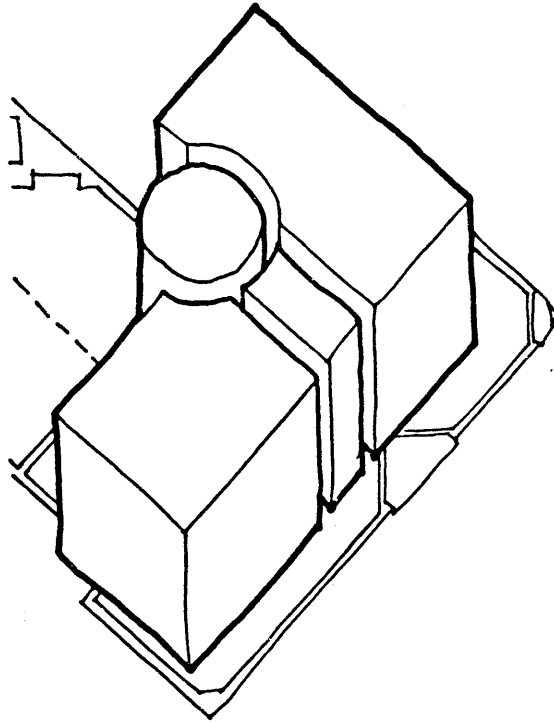



But this cracking can also be seen as addressing the fourth and final building aspect, FORMAL PREDISPOSITION. The most basic formal problem with the shoebox shape is stopping it, providing the suggestion of a convincing reason why the box is not more extended in either direction. By several formal relations discussed above, the perception is engendered that the space of the shoebox is contained by a continuous skin. By suggesting that this stiff skin has spread apart along a crack, the wedge reveals the (imagined) original, uncracked extent of the box; thus, by simultaneously splitting the form and holding it back from further expansion, the wedge tells both how the box got to be the size it is and why it can get no bigger. Easily its most striking feature, the wedge rationalizes the shape of the box, ties it back to the cylindrical stair, and articulates the form, providing yet another place where imagined parts are simultaneously linked and separated.

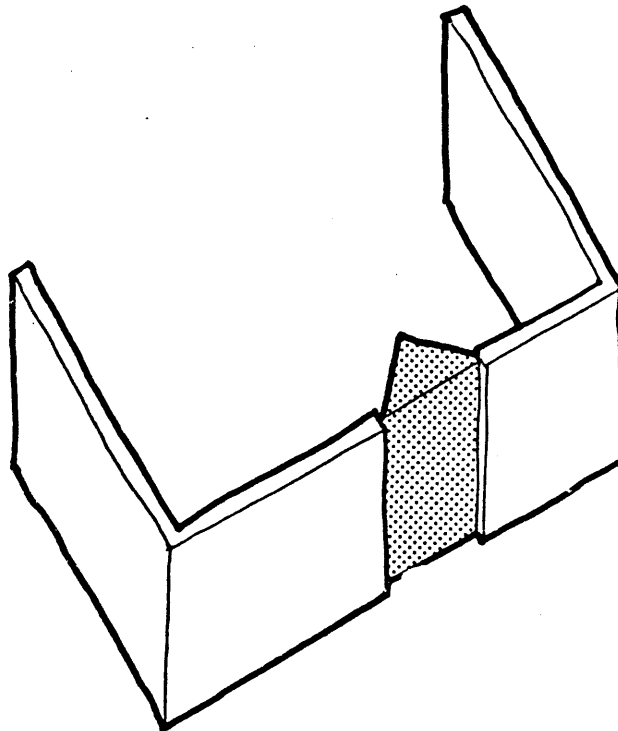

# Second Presentation

Insofar as there is any polemical motivation behind this second presentation, it is only this: I believe that back of the phenomenon of popular perception there is a kind of systematic rigor that is appropriate for and sufficient to the task of that type of perception; but I further believe that, if one reveals the nature of this rigor, making its structure overt and understandable, then it would be possible to construct a sophisticated analytical system upon the base of that structure. The immediate and natural reaction to this assertion is that analyses based on "naive" perception could only produce trivial results. This presentation takes the opposite view-- that one can indeed construct an analytical framework of precision and depth that nevertheless remains faithful to its base in popular perception. Recognizing the onorthodoxy of this view, this second presentation will, at times, take on the character of a pre-emptive defense, a response to objections that might be raised about its assertions. As such, the first section will try to show why several existing analytical systems are inadequate for my purposes; the second long section will then show how the analytical model is structured to reflect the logic of popular perception; and the sections following this (the "defensive" sections) will try to show, first, how the system's structure parallels that of two other constructed systems; then,

how its particular analytical perspective reveals opportunities foreclosed to other critical systems; next, how its structure avoids some of the dangers of excess that other systems pose; and finally, how it might open up possibilities for knowledge in areas outside its own field.

To focus the presentation of these existing analytical systems, I want to concentrate attention on the way each handles two relations: first, the relation between architecture's nature as object for use and its complimentary quality as an object for meaning and association; and second, the relation between the making of the object (here treated as the abstraction "the architect") and the public at large. The questions of proper relation raised here are, of course, not new; and my answers cannot hope to settle controversies that are no doubt as old as institutionalized architecture itself. But these relations do supply a revealing framework upon which to mount the ideas of the first section. Specifically, I will first try to show how the ways in which four current movements have dealt with the relation of the artist to the public are inadequate; I will then show how the model employed in the previous design sections handles the artist-public relation in a way that both meets these inadequacies and, in so doing, also supplies an answer to the question of

the dual nature of the object.

To a conventional Fine Art view (in an extreme form) the question of art's relation to the public simply does not arise: art's primary responsibility, this view would contend, is to itself, that one makes art in order to maintain and develop certain historical values that have an existence apart from those of the world, though not necessarily in opposition to them. The outcome of this is that--except during those rare times when the values of art and those of the world happen to coincide--the products of art will be meaningless to those not attuned to the latest state of developing art values. But more: since these values must inevitably constitute an ideology, a viewer of art might find the products of these values not merely meaningless but actively offensive--that is, such a work might espouse values not merely without connection to his own, but actually in opposition to them, a situation that might produce an expansion of awareness on those occasions when one is ready for it, but which is hardly appropriate for an environment in which one must spend considerable amounts of time.

If this position of ideology might be said to describe that of art, than a position against this would shun any ideology; and indeed the tendency most conventionally characterized as anti-art is the Pop sensibility (or, if one insists, "ideology") in which one merely catalogs,

without comment, the world as (selectively) observed. That is, certain portions of the environment are brought to the viewer's attention by being bracketed--by being made more noticeable than the unchosen portions by virtue of a move such as enframement, a change of scale, or a change of context. But the inadequacy of this approach as a model for the artist's relation to the public springs from this very bracketing process. For bracketing, at base, merely involves the declaring of a distinction between "the chosen" and "the rest of the world:" it does not tell us anything about the character of the relation between the two--the result for architecture being that, once one has drawn out from the world this repertoire of elements familiar to the public, one is still left with the question of how to redeploy them back into the world in built form. One might, of course, play up this condition (as in the work of Hardy Holzmann Pfeiffer where familiar objects appear in unusual contexts), but this move of making the familiar strange again confronts the viewer with an ideological environment from which he might not be able to escape.

The flaw of the bracketing sensibility as a model is that it makes no effort to understand the forces behind the physical manifestations it highlights; in effect, it amounts to playing a spotlight over only the surface features of the world, producing vivid but global and unspecific

impressions of relatively broad portions of the environment.

An alternative to this spotlight view of the world could be the model of Claude Levi-Strauss' anthropology--which might be said, conversely, to view the world through a microscope. This approach recognizes that there is a logic behind such phenomena, but it contends that that logic either cannot be known or else, if known, would be of a kind that would not make sense to our normal way of (consciously) thinking. Thus, this approach focuses in on the phenomena of the world, breaks them up into the smallest possible elements, and then reassembles them according to a constructed logic. For the architect and his relation to the public, this model would imply that the process of designing new environments for the public would be one of isolating the relevant elements from existing analyzable environments and recombining them according to a constructed architectural logic. Whether this can indeed be done remains to be seen, but the idea itself raises the spectre of design decisions from which there is no appeal, the decision being based on unassailable "scientific law." We have all witnessed the results of this sort of scientific determinism in the case in which psychological studies declared pale green to be the most desirable color for office walls.

But more revealing, I think, is the

realization that all three of these models hold the world of the public at arm's length, either by ignoring its presence, by confronting only its surface features, or by denying the validity of the logic that underlies it. The alternative to this detached attitude is one of total immersion in the popular and the vernacular. In this model the architect pursues an understanding of the public's environment that will avoid the pitfalls of detachment: by abandoning all prior ideologies, he opens himself fully to the desires of the public as expressed in their words and artifacts. In his role as a designer, then, his relation to the public would ideally be as a transparent conduit for translating their desires and values into form, directly and without intervention. To me, however, there are several disturbing features of this model. First and most obviously it views the values of the public as practically unassailable--almost as if they were phenomena of nature, subject to immutable laws, either those of an supposed authentic human nature or else those of mass probability. This tendency not to question the values and manifestations of the public (however defined) raises the considerable danger of a non-judgemental endorsement of any existing condition. For the architect trained in the values of high art, it also betrays a certain nostalgie de la boue, an acute realization of the contingency of the created world

that leads to a yearning for a certitude of less artificial values. But most of all, this attitude ultimately patronizes the very public it seeks to emulate: by not questioning the values and "giving them just what they ask for," the designer implicitly discounts the possibility that popular values can change and develop in response to challenge. For ultimately the total-immersion designer is not really one with the vernacular at all: once he has opened the Pandora's box of high art, he will not--probably cannot--experience the vernacular world as a participant does, as the ongoing and adjusting flow of time that constitutes the whole of one's daily life. Instead, inevitably, his view of that flow will be like an album of snapshots: a series of images, each of them full of meaning and intensely felt but inevitably detached from the flow of life, frozen to a specific point in time.

In fact this stance of estrangement characterizes all four of these models: they all betray a tragic/heroic view of "a world beyond my influence;" either through indifference, unwillingness, denial, or choice, all four avoid confronting the world and working their will upon it. But by the nature of his product the building, the architect will act both in the world and upon it, and the world will react to his actions. This may sound trivially obvious, but a crucial point turns on the nature of the world's "reacting:" for, except on the rarest of occasions, the



architect and the public never come face to face in the roles of building-maker and building-user; in a real sense, the only way an architect (qua architect) can act upon the world is through his buildings; likewise, the only thing to which the viewer can react is the building. Any "reaction" therefore must be of a specific, almost metaphorical kind. What I want to postulate here is the idea that this special kind of reaction occurs whenever a viewer has thoughts as to why a form is a certain way--that, is, when he looks at a form as an intentional creation.

It is important that I stop at this juncture and emphasize the importance of this definition. At the outset of this presentation I stated that I wanted to ground this system of analysis in popular perception. Now, the core of any system that hopes to analyze phenomena should be its particular vision of the activity of interpretation; the interpretation done by a system based on popular perception ought to be of a kind that is in some way congruent with the way ordinary people see. Popular Culture studies have claimed to do this, but these studies have failed to produce any rigorous analysis of the public's view of the world; and the reason, I believe, is that they assume the public sees in only one "common-ordinary" way: these studies forget that each of us has myriad schemata with which to view the world, some systematic and focused, others more diffuse (even art critics do

not view everything with the perspective of esthetic analysis). One of these ways is that mentioned above--looking at a form, deciding it was deliberately made, and asking why it was made in that particular way. What I have done, then, is to take as a base this most contemplative and analytical of the ways of seeing an ordinary person might use and then reconstruct that perspective into a systematic, manipulable model. The remaining parts of this section will show how this basic perspective can be developed into a system of some sophistication while still remaining consistent with its original purpose of systematizing one popular way of viewing buildings--that particular way that looks at form as an intentional creation and contemplates why that form is the way it is. Thus, when I use the term "interpretation," this is the type of activity I mean to refer to.

By thus redefining interpretation, I hope to avoid many of the problems more conventional systems present. For example, note that under this system's definition, interpretation would only provide an account of why an intentional form had a certain configuration: it would not concern itself with why the maker of the form fashioned it in that way. Far from being a diminution in explanatory power, I think this stance focuses the attentions of the analyst in a direction that is potentially more fruitful for the analyst and certainly more useful for the public.

Specifically, by demanding that interpretation attend to the intentions of the artist, one places insurmountable barriers before the viewer who has neither the time nor the motivation for the concentrated study necessary to establish a single, supposedly-correct reading. Plus, this correct reading can be truly known-for-certain only when the actual designer has stated it, a condition rare in new buildings and virtually non-existent in older ones. But these are merely practical limitations: the basic drawback, as I see it, in an exclusive focus upon the designer's vision of his building is that it discounts all other possible ways of experiencing that building, and in so doing, refuses to take the perceptions of the public into account. That is, the only times that the architect's intentionality can be seen as "involved in the world" are those times when the person using a form for his daily activities thinks about the reasons why the form might be "that particular way:" if there were to be only one permissible reason, one interpretation ("that counter was placed here only to divide this room"), then that interpretation would be applicable only at the times when the types of activity consonant with that interpretation were taking place; for each activity during which the form is used in a different way, the insistence on one interpretation would foreclose the possibility of considering that form as intentionally-made to

\*This is, in fact, the basis for the idea, shown in the Design sections, that one should not impose upon the viewer a form whose only reason for existence was to "express something" or whose presence the viewer could not ignore.

also meet that activity. Seen in another light, an ordinary person might reasonably explain the configuration of a particular form in a variety of ways, each explanation according with and making sense of the experience of a specific time; the system I'm constructing tries to honor this phenomenon by defining interpretation as it does: this system tries to account for those explanations, systematize them, and base an analytical structure on them.

But by the same token, there will be times when this same ordinary person uses a form only as an expedient instrument, with no thought as to its provenance or place in a scheme of things; indeed, to be forced to interpret a form at such a time would constitute the coercion of an ideology that I condemned earlier.\* Thus the system, to match this aspect of public perception, must be constructed so that it can be selectively invoked (a requirement that is addressed later in this section; but note that, by confining its operations to only those perceptions that could arise when viewing with a particular way of seeing, the system need not account for those perceptions that stem from other orientations.). This aspect of optionality, then, completes the characterization, sought at the outset, of the relation between the architect and the public: that is, in the terms used in this system, the architect's proper relation to the public is one in which the public, at its option, connects with

the architect by interpreting his intentionality; an architecture that reflected this relationship would be one that signalled to the viewer that a system of intentionally-deployed forms did exist within the building, awaiting his optionally-exercised interpretation.

And in like fashion, this notion of an architecture that awaits the manipulation of the viewer addresses the other question posed at the beginning of this section, that of the relation between the building as a useful instrument and the building as a source of meaning and association. For just as the viewer must be left free to interpret the building's forms in any reasonable way that provides meaning for him, so must he be free to use those forms in any reasonable way that meets his functional needs.

Now, there are two ways in which these manipulations of use and interpretation can become so extreme as to sever the connection between the viewer and architect. Although both situations result from the types of manipulations that are perfectly permissible (and necessary) for everyday activities, in both cases the viewer's conceptions would be such as to fall outside the analytical system because they would be based, not on the intentionality he could reasonably perceive in the building, but instead on pre-existent notions that the viewer would have brought to the building. In the first instance, a person might, in his manipulations to

give a rationale for seen forms, contemplate and interpret an element that was not deliberately formed and could not reasonably be seen as such--in effect, reading pre-existing meanings and associations into an element that was purely fortuitous. Examples of this "boutique sensibility" abound in, for example, the amount of sentiment overlaid onto found industrial spaces and manufactured items of the last century. One might find genuine delight in these speculations, but they so strain any connection to a possible base in intentionality that they go beyond the bounds of the system into a condition one might call fatuousness. Conversely, a person, might, in his manipulations to satisfy his own needs, so completely ignore the intentional aspects of an object that again any reasonable connection to the deliberate making of the object would be severed; and again, even though this is and must be a common occurrence in daily life, the connections of use and form that one would make in this situation go beyond the limits of the system into a condition one might term exploitation. Each of us partakes of this exploitative sensibility every time we merely use an artistically-formed object (the danger involved with this condition occurs when one sees with only the exploitative sensibility: exploitation, in fact, is the inevitable precondition for the unopposed destruction of a building of quality.).

Now, assume for a moment that these

\*Seen in these terms, the two orientations also suggest the two polar frames of mind with which one would approach tools or objects (all use) and words (all interpretation)--a distinction treated in the section on Parallels.

two conditions represent the end-regions on a continuum of possible orientations-to-form, exploitation connoting a focus on use to the exclusion of interpretation, fatuousness being the complimentary exclusive focus on interpretation.\* One can easily see that the kind of interpretation-consonant-with-use I have been discussing all along is modeled by the middle, mixed region of this spectrum. Next, consider, also for a moment, the fact that (for its own operations) the analytical system need deal with only two ways of seeing form: interpretation (the perspective it is constructed specifically to account for) and all other ways. The continuum thus provides a visual analog to this condition, fatuousness and exploitation covering all those perceptions that do not match the definition of interpretation. As such, the constructions exploitation and fatuousness can be seen as elastic boundaries to the analytical system--boundaries because they denote the regions that fall outside the purview of the system, but elastic because there could never be (and, to maintain freedom, should never be) a consensus of agreement about where on the continuum either condition could be said to begin.

But even if elastic, it is nevertheless essential that this analytical system be bounded. Jean Piaget, in his Main Trends in Interdisciplinary Research,<sup>2</sup> discusses various ways in which one might construct systems of analysis and points up the

limitations which must be observed in the construction of each. In the matter of boundedness, he notes that the commonsense assumption is that the analytical system can operate only when the class of data upon which it is based is defined by empirical observation external to the system--as in the case of, say, astronomy where (to the conventional view) the class of phenomena to be explained is defined as all those phenomena recorded by the (unbiased, empirical) telescope. The fallacies behind this view have been revealed by Popper and others,<sup>3</sup> but Piaget goes farther and points out that, even if the limits of its data base cannot be defined in such an all-or-nothing observational manner, an analytical system can still be constructed if it postulates an inclusion criterion: by doing this, the system, in effect, establishes a certain set of characteristics, recognizes only phenomena possessing those characteristics, and then fashions a structure which holds and accounts for each recognized phenomenon. Thus the system can claim a kind of comprehensiveness because it accounts for every phenomenon it recognizes; but by the same token, its applicability as an explanatory tool is likewise limited to the realm of phenomena defined and bounded by the inclusion criterion.

This notion of an analyst-postulated realm of phenomena has a reflection on the work of Michel Foucault. In his



book The Archaeology of Knowledge<sup>4</sup>

Foucault proposes a study of history that takes as its base the recorded statement--that is, any statement by any person that has come down to the present in a recorded form. To confront this huge volume of data en bloc would, of course, be impossible; but Foucault proposes applying a whole series of inclusion criteria to the mass to form planes of discourse--in effect, groups of statements sharing a common attribute. Foucault proposes a rich array of possible inclusion criteria (examples of which might include "statements about insanity" or "statements by doctors" or even "statements branded as irresponsible by the authorities") and then proposes that for each plane a structure could be set up that would relate each statement to the others. By so doing, not only would the analyst account for all the (chosen) statements, but more interestingly, the account itself would be an analysis and explanation of the statements encompassed by the plane of discourse (providing, for example, an explanation of eighteenth-century France's view of insanity).

As Piaget's analysis points out, these explanations, of course, can be applied only within the realm of phenomena from which they are drawn, but the important point to consider here is that, while the analyst can establish any inclusion criterion that will give him planes of discourse helpful for his studies, these

criteria need not necessarily be abstruse or unusual; they might, indeed, be criteria widely and reasonably held by the public. When this is the case, the analyst might be said to be dealing with a "pre-existing" plane of discourse--this existence being of a special kind since any plane of discourse is a construction whose only existence is in the minds of those who recognize it.

Foucault himself has carried out an analysis of such a pre-existing plane of discourse in his I, Pierre Riviere...,<sup>5</sup> in which he presents a compilation of all the statements made by and about a man, Pierre Riviere, who brutally murdered his entire family in nineteenth-century France. The statements are revealing in themselves, but what is even more revealing is the phenomenon that occurs when, in effect, the public recognizes the existence of a plane of discourse. For though the fact of the murder was established by Riviere's actions, the way in which the crime was perceived by the public was not. In France at the time there existed a tradition of "hero-murderers," men whose crimes were seen as, in some sense, heroic acts because of the intolerable circumstances under which each murderer had found himself and from which the murder had freed him. Riviere's crime would have been viewed by the world as nothing more than a senseless slaying but for the fact that Riviere kept a journal in which he presented his version

of the circumstances behind his actions. By writing these statements (and by their dissemination to the public), Riviere caused his crime to be seen as, yes, a brutal murder but perhaps also a justified "hero-murder." In Foucault's terms, then, for the people of the time, their perceptions of Riviere's crime (as recorded in their statements) would exist on two planes of discourse--that of "murders as brutal crimes" and that of "murders as heroic acts." One might say that, by his writing, Riviere positioned (the perception of) his crime on a chosen plane of discourse.

This term positioning comes from a recent article<sup>6</sup> that shows how advertising campaigns are constructed to accomplish deliberately the type of positioning that Riviere's journal did inadvertently--to engender in the public's mind the perception that their product belongs in a specific, recognized group of other products. One of the examples given was an ad campaign for Volvo: here the advertising firm realized that if the public perceived the Volvo as an "economy import," that is, as belonging in the same group as Volkswagen and Datsun, then in comparison the Volvo would seem much too expensive; thus the ad campaign tried to get the public to see Volvo instead as a "luxury import" in a class with cars like Mercedes and BMW, in comparison to which the Volvo would seem a real bargain.

Of course, the planes of discourse

termed "luxury import" and "economy import" have no more empirical reality than did the plane of "murders as heroic acts," but neither must they be as capricious and fleeting as these creations of Madison Avenue; as categories in the public mind they may have a certain sort of existence that is felt as being quite real, and in the case of categories like murders, they might have more durability than any created object one could name. I emphasize these two points because I want the reader to see this notion of planes of discourse not simply as an interesting but arcane creation of Michel Foucault's mind, but as a systematization of one of the ways man actually does use to make sense of his world. Viewing the concept of the plane of discourse in this way raises the possibility that it might serve as a framework for systematizing the public's perception of architecture. This possibility takes on real plausibility when one makes a certain conceptual shift: that one view architecture not as a physical, empirical phenomenon, but as itself a plane of discourse--a conceptual creation layered over empirical reality and reflective of a chosen aspect of it. Or, to explain by analogy, with the case of Riviere, the fact of the murder was the empirical reality, but the public's perceptions of that fact were organized by Foucault onto planes of discourse; with architecture, similarly, the empirical reality would be the actual building, but

perceptions of that building--both recorded and projected--could be organized onto similar planes of discourse. But note that these planes would not be the arbitrary creation of the analyst: like Foucault's plane of murders-as-heroic-acts, the constructed planes for architecture would be rational reconstructions of categories (reasonably supposed to be) already existing in the public mind.

Given this notion, one can turn back to the continuum of possible orientations-to-form and see how each region of the continuum could be considered such a reconstructed category--the sensibility of "building forms as tools for use" being an example. The perceptions that one could reasonably suppose would flow from such sensibilities could thus be organized onto their respective planes of discourse, each plane a creation of the analyst but each still a rationalized reflection of an existing sensibility. Thus the plane that I am constructing and labelling "architecture" would be a repository for perceptions engendered by the existing sensibility that I have been calling interpretation, that particular orientation-to-form that sees building forms as deliberately-made objects for both use and interpretation.

Once one perceives architecture in this way, one also sees the task of the architect in a new light; that is, just as the efforts of Riviere and the ad company positioned their "products" so that the

public perceived them in a preferred way, so it becomes the task of the architect to position his work as architecture--to get the public to perceive the empirical reality of his building as an object for simultaneous use and interpretation. (Note here that, just as with Riviere's crime and the Volvo, this desired perception is only one of many perceptions that the public would have of the real object: a Volvo is necessarily also a mere means of conveyance. Positioning, in this sense, is the suggestion of an additional perception--a concept that, importantly, reflects the fact that, though the architecture may suggest, still it is the viewer who chooses his own orientation-to-form.)

There is a further parallel between the ad campaign and architecture, and that involves "customer satisfaction." With the Volvo, the advertisements suggested that the Volvo be seen as a "luxury import," implying to a potential buyer that the car had features and appointments comparable to those of the Mercedes; but in addition, the promotion had to involve more than just hints made in the ad copy: the car itself had also to perform a role in the positioning effort--that of making the proposition plausible by looking like a luxury import. The Volvo would have achieved this "look of luxury" with items like extra trim or carpeting--in short, through what might be termed manifestations of superfluosness. But if a buyer,

\*This process of "promises made and kept" need not be seen only on the crass level of salesmanship, but may be thought of as the basis for a bounded system of interactions between maker and viewer; seen in this way, such a system would achieve a state of equilibrium when the user accepted the maker's proposed positioning.

\*\*Note that I have not said that a person would necessarily perceive the exact configuration of the whole of the pattern. One deals here with the issue of intentions, and I have set up this system so that intentions need not be read, only connected with.

convinced enough by this double campaign to buy a Volvo, found that his new car had no more luxury than a Volkswagen, he would justifiably feel that he had been deceived, and the possibility of his ever again viewing Volvo as a luxury import would be foreclosed.\*

In an analogous effort to position perceptions of form, a building would achieve a "look of architecture" through manifestations of intentionality, signaling to the viewer (by devices like the intentional distortions used in the two designs) that he would be justified in viewing the building as architecture. And as with the Volvo's relation to the Mercedes, so with architecture: the suggestion that a building be viewed as architecture implies that the building has qualities comparable to those of other buildings that the public regards as indisputably Architecture. These implied qualities span a wide range (and will be discussed in more detail below) but there is one basic quality that a building must possess if the public's perception of it as architecture is to be maintained--the promise that the maker has arranged the forms according to a deliberate pattern, and that a person who "buys" the proposition and views the building as architecture will not find that he has been deceived into fatuous speculation. But not only this: by his own interpretations of the deliberate configurations of the forms,\*\* the viewer

will receive the satisfaction of seeing the building in a new way. If the viewer receives this satisfaction, then he would agree that considering this building as architecture is justified, and he would figuratively place his perceptions of the building on his own "plane of architecture," alongside and comparable to those remembered perceptions of other deliberately-patterned, multiply-understood, "architectural" buildings.

One can see how, under this constructed system, the architect and the public truly are connected--and in a way that leaves each free to act but which rewards acts of cooperation. I hope one can also see this constructed model in the same light as the planes of discourse--that is, not merely as an analytical construction, but also as a rationalization of an actual, commonly-occurring phenomenon, one that might be termed complicity.

With this notion of complicity, one can see how the system closes back upon itself: for just as complicity is the precondition for the reward of a greater understanding, so the perceived intentionality (that engenders that understanding) is the necessary precondition for the phenomenon of complicity. One can now see the two phenomena of fatuousness and exploitation as descriptions of the situations when the necessary preconditions for complicity--and thus its rewards--are not met; that is, situations in which the viewer's perceptions



fail to involve manifested intentionality-- in the case of fatuousness, because it does not exist, in the case of exploitation, because it is ignored. In short, one might look upon fatuousness as complicity exercised without justification, where exploitation would be a case of complicity withheld where it was justified.

To summarize in the terms with which I began this section: when a person views a building as architecture and he perceives the intentionality manifested there, then complicity occurs and the architect and the viewer are connected because their perceptions can be thought of as positioned on the same plane of discourse.

The structure of this analytical system is now almost complete; the final point that remains to be covered is this: I have stated that the connection of complicity occurs when architect and viewer have perceptions of the same character, but I have yet to describe what the character of those perceptions might be. That is, so far they have been described only as perceptions that arise when one views building forms as both tools for use and objects for interpretation; the question to be answered is, what is to be the relation between use and interpretation?

The answer can be approached at two levels: on the level of constructing an analytical system that operates in a clear and rational manner, what is desired is

a way of deciding which perceptions the system will recognize and deal with; in the terms used so far, this level seeks a Piagetian inclusion criterion that describes the character of the perceptions and not just the nature of their source, and thus provides a way of determining which perceptions are to be permitted onto the plane of architectural discourse. In a sense, this level seeks an answer that fits and supports the constructed operations of the system; but the other approach is to seek an answer that matches the observed real-world operations that the system tries to model. The desired condition, of course, is that the two answers will coincide--that, like the concepts of complicity and planes of discourse, they will be not merely analytical constructions but also rationalizations of actual phenomena that occur in the world. From this perspective, one could seek an answer by looking at the perceptions of the architect, postulating that the connection of complicity would occur when the viewer had perceptions of the same character. In other words, if the nature of perceptions is a function of one's orientation-to-form, then the connection can be said to occur when the viewer looks at the building with the same orientation-to-form that the architect had when designing it. How, then, does the architect view form?

The answer to this question is crucial

for this system's relation to the world, for if it is truly to describe the way one should view architecture to achieve the rewards of complicity, then it ought to be applicable to (almost) any architecture a viewer might look at. But I think I am on relatively safe ground if I state that (American, twentieth-century) architects view form as a means with which to accomplish the building task set before them. Two important points arise from this statement: the first being that the building task is not to be seen as merely the programmatic and mechanical requirements of shelter, but as a statement of the total situation the building is to address; as such, the building task can be seen as a set of inevitably-conflicting conditions-to-be-provided, requirements which are stated by the client or mandated by law and custom or revealed by empirical tests and analyses or--and probably most importantly--set by the architect for himself. The second point involves the accomplishment of this task: it is not enough for the architect merely to take each requirement individually, provide an appropriate accommodation for it, and then assemble the individual accommodations. To do so would mean that any interpretation of the resulting building would be fatuous because each individual form would be no more than a reflection of its use aspect: its making would have involved no considerations other than

those of function; there would have been no intentionality involved in the making of the forms and so no basis for a connection between architect and viewer.

But more vital than these considerations of system-functioning is the requirement that the system be a rationalized reflection of the existent world, and the obvious fact is that architects simply do not work this way: this is not to say that they should or should not, only that to view buildings as if they were designed in this manner would be fundamentally to misperceive the built environment as it now exists. The architect does not (and probably cannot and should not) simply take the stated requirements and translate them directly and mechanically into form. The thing to which the architect gives form is his own conception of those requirements--but not a conception that merely restates the requirements as a listing, nor one that summarizes them in the fashion of a hierarchically-ordered outline. Rather, the architect seeks a conception more like an aphorism, an insight that takes the parts of the building situation and "makes them all fall into place," a design conception that reveals a previously-unseen order into which the individual parts can be fit (in exactly the manner of the subsuming understanding that occasions the "Aha!" reaction).

Given this notion, one can now characterize the relation of use and

\*I am, of course, referring here to "use" in its widest sense, not just its strictly functional dimension.

interpretation in the architect's orientation-to-form--and by extension, that of the complicitous viewer. For the insight represented by the architect's design conception is itself an interpretation of factors of use:\* because he deliberately gives form to this derived total conception and does not mechanically match up individual forms and needs, the architect uses form in an intentional manner, one that reflects his own ordered vision of the building and not just the found order of a building program. In other terms, the architectural way of accommodating the building situation is by deliberately using form to make concrete a resolved conception of it. Thus, to view form in the architectural way--to see a building as architecture--is to view it as a deliberate reflection of a building situation.

Important implications flow from the dual notion that an architect's design conception is like an aphorism and that a building's forms can be viewed as its reflection. First of all, it is the delightful nature of an aphorism that one can never pin down precisely what it means because it can be interpreted in so many ways. But this is precisely the power of aphorisms and the reason for their durability; for although the interpretations they suggest are different and sometimes even contradictory, somehow when brought together in the mind they reveal a kind of sense, a larger insight

seen before. The process might be described as a kind of synergy of interpretation: by suggesting a multiplicity of meanings, the aphorism might be said to force the mind to juggle the various notions until something clicks and a new idea emerges that reconciles them all. The aphorism thus comes to "mean" more than just the sum of its individual interpretations.

This is precisely the effect I observed in the analysis of the Browne house: multiple ways of reading the forms that could not be reconciled until a new notion--contained in none of the individual readings--occurred to me that "made it all fall into place." Of course, I am certain that all of my interpretations did not occur to Richardson; and I am just as certain that some of his intentions did not occur to me. But this is exactly the point: if I had approached the house with the purpose of second-guessing Richardson, trying to list his intentions as seen in the forms, the synergistic understanding would never have occurred; plus, I could never have discovered all that Richardson intended to do--and even if I could have, just having that sum of intentions would not have caused my mind to "click into place" because my mind is not his. The understanding and delight of multiple interpretations came to me only because I was free to interpret according to my own vision.

But it is also obvious that my speculations could not have been completely freewheeling or capricious: in order to avoid that condition I labelled fatuousness, I had to limit my interpretations to only those that explained how a perceived formal relation could be seen as a deliberate reflection of some aspect of the building situation. And again, I imposed this restriction not merely to insure the smooth functioning of my analytical system, but in order to reflect (in a systematic way) a consideration that any person viewing buildings must keep in mind. For, if I am concerned that buildings have "meanings and associations for ordinary people," the possibility of this can only occur if the rewards of interpretation make it worth the effort (the "customer satisfaction" I mentioned earlier). Every time a person's interpretation of a building is revealed as fatuous, that person's willingness to try again would naturally diminish, being replaced eventually by a skepticism about the whole enterprise of looking at buildings as architecture.

An example of a situation that would engender such skepticism is this streetscape of shopfronts (shown on the next page), whose configuration one might interpret as reflecting a charming resolution of the requirements of village commerce, but which is actually a newly-designed facade for a modern hotel. A viewer who recognized this condition



and refrained from reading any meaning into the forms he saw would be enacting the process of which this constructed system is a rationalization: that is, the viewer looks at the shopfronts, decides something is "fishy" about the scene, and does not allow himself to slip into a frame of mind in which, for example, he might look at a curious quirk of form as a clever reflection of some building requirement; in the terms of the system, he decides that it would be



pointless to look at the shopfronts as architecture because plainly they are not a deliberate reflection of their building situation. By thus withholding his complicity, he avoids being caught in the fatuous position of extending himself to connect with an intentionality that is not there.

Let me now conclude this section with an insight that results when one compares the experience of the viewer of the streetscape with my experience of viewing the Browne house. I experienced delight at having glimpsed insights I had not seen before, while the viewer experienced only disappointment and a feeling of having been deceived. In one case a person gains new knowledge and an expansion of visual awareness, in the other, a person gains nothing but an increased suspicion that will likely decrease his openness to visual experience. All this contrast, but note that the "empirical reality" of both situations is the same: "a person stands before a building and looks at it." Clearly the mental states that arose from these two situations were not the result merely of confronting objective reality; rather, both were cases in which perceptions were compared with and played against a system of conventions. Far from being objective, both the perceptions and the conventions are products of a specific culture and time--so that not only can these mental occurrences not be seen as

\*One can thus see how fatuousness and exploitation exemplify the strict consequences of "straying beyond the borders:" with the fatuous situation of the streetscape, one did not get merely diminished participation of the system and its rewards, the system ceased to be applicable at all.

(empirically) "real," they likewise cannot lay claim to the quasi-real status of "universally-occurring." All of which could make one somewhat uneasy, wondering where this system might touch ground.

But as I see it, this is a misplaced concern: to try to ground a view of architecture on some verifiable rock of universal or empirical reality may not be entirely futile, but to me it seems unnecessary. Better to work from the basic assumption that there can be no verifiable, empirical qualities that constitute architecture, that as stated before, architecture is itself a cultural category, one which is of long standing but which has no existence apart from the cultural conventions that define it at each time and place. One can see how taking this position would naturally lead to my contention that the way to see architecture is in a way that emulates the perceptions of the public--a way that, in effect, reflects those defining conventions. But by avoiding the superficial global view of those conventions and searching for a rigorous logic back of them, I found that the nature of that rigor is one of almost complete freedom of action within elastically-defined but strictly-enforced borders\* (a rigor for which the plane of discourse provided a compelling visual analog). So, in reflection of this quality, this system is one in which judgements of correctness are not made, in which "anything goes" as

\*which is, of course, not to say that the views of critics are barred: if presented so as not to restrict the viewer's freedom of interpretation, they can, in fact, be helpful in showing one how to "sense more;" see the final section on Possibilities.

long as one does not transgress the borders. These borders are, in fact, the source of the system's rigor, for the precision of the system takes the form not of correctness but of justifiability: the only interpretations that are permitted are those that are justifiable (within the borders of the plane of architectural perception or, in the terms of the system, any interpretation that explains form as a deliberate reflection of a building situation); but by the same token, any interpretation that is justifiable is permitted. Seeing this condition, I realized how appropriate it is to a system of and for ordinary people; for it means that the system can function (to a great extent) by itself: it does not require the ministrations of authorities to adjust and set standards of acceptability and correctness. A person using the system (or more precisely, using the perception of which this system is a model) would find for himself if his interpretation is justifiable (non-fatuous), just as the viewer of the streetscape did. And in like fashion, he could gain the rewards of using the system without the need for outside help\* (as I found at the Browne house). It is, in short, a system eminently suited to the needs of amateurs.

Given this, the rest of the presentation will try to show how the system can also serve the needs of "professionals."

# Parallels

There is an existing system that is similar to the system I've constructed in that it, too, allows one to operate as he pleases as long as he does not transgress the system's boundary-of-the-permissible, and that is the system of jurisprudence.<sup>7</sup> The law also exemplifies the way in which a constructed system can emulate and elaborate a found cultural system (the system of customs of which law is a codified outgrowth) while still remaining faithful to the basic core of that system (the character of that faithfulness being conveyed by what I've called the "Aha!" reaction, in which the explanation of the law's complex workings subsumed the public's customary notion of "fairness.")

The most significant parallel is that, like architecture, the law has no empirical or universal standards to which it can appeal: both are ongoing creations of the culture in which they exist. But what the law reveals is that, for a culturally-created category, "ongoingness" can impart a validity comparable (in the public's mind) to the validity conferred by empirical verification. That is, the public's willingness to accept the law and submit to its dictates is based upon the law's continually-demonstrated reliability (it delivers what it promises: like the Volvo and the Browne house, it gives "customer satisfaction"). Or, in other terms, our respect for the law is

based in our belief that the system has worked rather well in the past; one therefore submits to each successive new decision because (and only when) it meets the same standards, conforms to the same definition as those (respected) laws of the past.

In the last section, I postulated that architecture could be defined as a deliberate reflection of a building situation; one could similarly define a legal decision as a "reasoned response to a justiciable action." For architecture I set up the model that a perception meeting this criterion could be positioned on a hypothetical discursive plane and thus seen as comparable to other examples from other times. In law, continuity with its (created) past is made even more overt through the maintenance of an archive of all decisions. As a compilation of all "reasoned responses to justiciable actions," the archive is an embodiment of the notion of a discursive plane: an array of all the statements that are justifiable by virtue of meeting an inclusion criterion. In this light, one can view the ratio decidendi (the judge's reasoning) of a decision as the judge's version on how his decision ought to be seen as a reasoned response to the justiciable action brought before him--in effect, an attempt to position his ruling "as law" on the plane of legal discourse.

But the most revealing parallel between

the law and this analytical system is this: just as the architectural system allowed one freely to interpret any perception justifiably seen as "architectural," so the decisions in the legal archive likewise are not given fixed interpretations. That is, a person (figuratively) leafing through such an archive would find no decisions marked as favored, would find no preference given to historically-prior decisions, would see no importance assigned by virtue of agreement with the preponderance of rulings.

In the terms of the discursive plane, the decisions could be seen as arrayed unhierarchically, each item undifferentiated from the rest. Any differentiation--any interpretations imputing quality or importance--would be only in the eyes of the viewer, the differentiation being done by postulating that certain items be seen as related to certain other items in a specified way ("A is more profound than B, less rigorous than C..."). In law, this process has a name--distinguishing--and is the process by which a judge cites other decisions as precedents for his own ruling; in distinguishing cases, the judge points out selected cases whose logic seems to provide an answer to the problem of the case at hand and then shows how his decision conforms to and continues that logic; the judge then points out other cases whose logic would

give rise to a contradictory answer and gives reasons why those cases do not or should not apply. In the terms of the discursive plane, the judge thus postulates relations between his decision and selected others.

The analogous process in architecture would be, of course, much more fluid; but nevertheless, by the disposition of his forms, an architect can put forth the suggestion that his building be seen as related to certain structures of the past. Just how this can be done is a question, like that of how judges should arrive at their decisions, best left to the individual architect. The more important point to be drawn from this discussion is that here one has two systems that view both history (the relations between items of different times) and quality (the standards by which items are given a ranked relation) as no more than conditional postulations. In the next part of this section I will present a third such system--the method of poetic analysis used by Harold Bloom--which will, I hope, help convince the reader of the plausibility of this unorthodox view.

The possibility of using Harold Bloom's method of analyzing poetry<sup>8</sup> as a model for a method of analyzing architecture occurred to me because of Bloom's repeated emphasis on the notion of words as objects: poems are made of words, architecture is

made of objects; could there be a connection? In what ways is the nature of words like the nature of objects?

Bloom points out that, while the recorded form of a word passes through time intact, the import of that word is different at each point in time. It is a false notion that words can be transparent conveyors of meaning: by their nature, words partake of some of the opaque, unreadable quality of artifacts.

This realization is particularly acute for poetics: because of the imperfect match between word and meaning, one cannot authentically use words to interpret a poem: to do so would be to use a (somewhat opaque) object to explain another (equally opaque) object. All that one can truly do is to paraphrase a poem--in effect, to relate or compare two objects. But the result of this limitation is that one can only either retell the poem exactly by comparing it with a twin (a tautology that would yield nothing) or else compare it with an object not exactly alike--in essence, to misread it.

But Bloom does not see this as an undesirable situation; far from it: for not only is misreading inevitable because of the nature of words, it is also intentional due to the nature of art. To explain: as a creation based on conventions, a work of art is seen only in relation to other works of art: any



import it might have for the viewer is the result of the viewer comparing it to other works of art. Knowing this, the artist naturally despairs of ever having his work seen as greater than that to which the viewing public compares it. To get around this condition, the artist inevitably misreads these previous comparable works, interpreting them on the basis of criteria other than those (generally assumed to have been) used by the predecessor-artist--criteria on the basis of which the new artist's work would be judged superior to the previous work; the artist's task, then, is so to configure his work that the public will be convinced of its "rightness"--in effect, accepting his postulated criteria as the appropriate ones to use for interpretation.

Although intended as a description of the process of innovation in poetry, this account can also be seen as a description of Bloom's views of the nature of art and of the nature of words (and thus objects); as such, let me summarize each in this way:

The nature of words and objects might be characterized by ATEMPORALITY (neither the recorded word nor the object changes form as it passes through time) and OPACITY (both are at least somewhat uninterpretable). In like fashion, the nature of art could be described by INTENTIONALITY (the artist deliberately misreads) and INNOVATION (the artist works

to have his work seen as doing something better than that which came before). Now these terms are descriptive enough, but there seems at first glance to be no basis upon which they might be related. But by viewing Bloom's system in the terms of Foucault's planes of discourse, the four terms can be seen as describing the essential characteristics of items on a discursive plane. To diagram this relationship, one could make the following analogies:

ATEMPORALITY : DISPERSION

When arrayed on a plane, the discursive items are not positioned according to "which came before;" they are dispersed freely and unhierarchically across the surface of the plane. In fact, the dimension of time is avoided altogether, and the relations between items are spatial; that is, they are related on the basis of adjacency.

OPAQUENESS : ADJACENCY

With an opaque word or object, the thing itself contains no inherent import: its import is contained fully in the nature of its relationships with other objects. Thus the interpretation of an object is rooted in the relation of adjacency.

INTENTIONALITY : POSITIONING

The focus of the artist's efforts is to get his work seen as related to (and potentially greater than) a body of existing works. Like Pierre Riviere, the Volvo advertisers, and the judge in his

ruling, the artist wants his work to be seen as occupying a position on a chosen plane of discourse.

#### INNOVATION : DISPLACEMENT

Not only does the artist want his work to be seen on the same plane as the predecessor, he wants to occupy the precise position of the predecessor: that is, he wants his work to have the predecessor's set of relations-to-other-works. Since in this model these relations are spatial, the new work can acquire these relationships only by displacing the predecessor.

Thus the artist's task becomes one of moving the predecessor out of the way--in an almost-physical sense, clearing out artistic space for his own freedom. Bloom describes six ratios or ways of achieving this displacement; following the notion that this system can be mapped as a series of spatial relationships, I have diagrammed these six ratios in the following form:

If one visualizes a plane covered with dots, each dot symbolizing a work, one of those dots would be the predecessor-work--the work considered superior by virtue of the (spatial) relations it has to all the other works; its superiority (and its import) is thus a function of its precise location on the plane: erasing those other works, the black dot in the diagram pin-points that favored location. The two circles can thus be seen as elaborations-in-space of the import of that locus, the dashed circle being the predecessor,

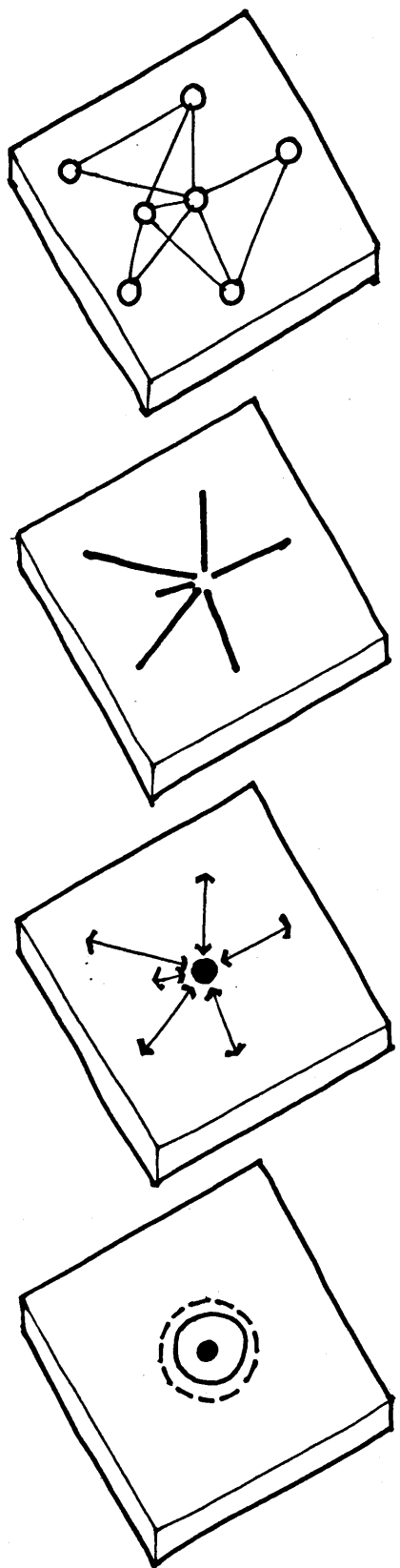

the solid one the successor. As long as they share that particular locus, they will have the same net of relationships and thus the same import: they will be seen to "mean the same thing," and thus their adjudged quality in relation to that meaning would be a function of their (interpreted) spatial relation to that locus of meaning.

The six ratios are:

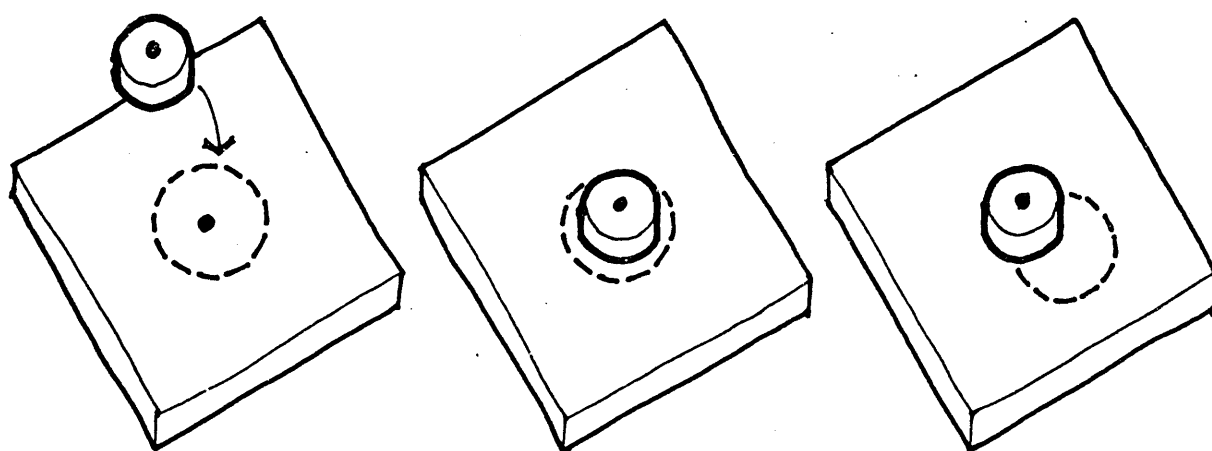

CLINAMEN, which Bloom also terms SWERVING. Here the new work is positioned at the locus and immediately the old work comes to be seen as a misdirected development of that locus.

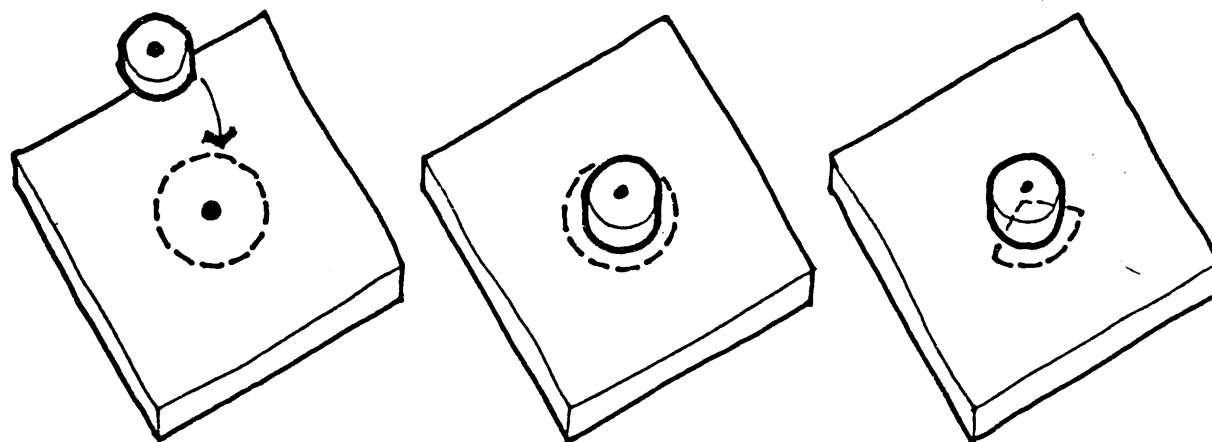

TESSERA, or COMPLETION. In this case

the older work comes to be seen as an incomplete elaboration of the locus of meaning.

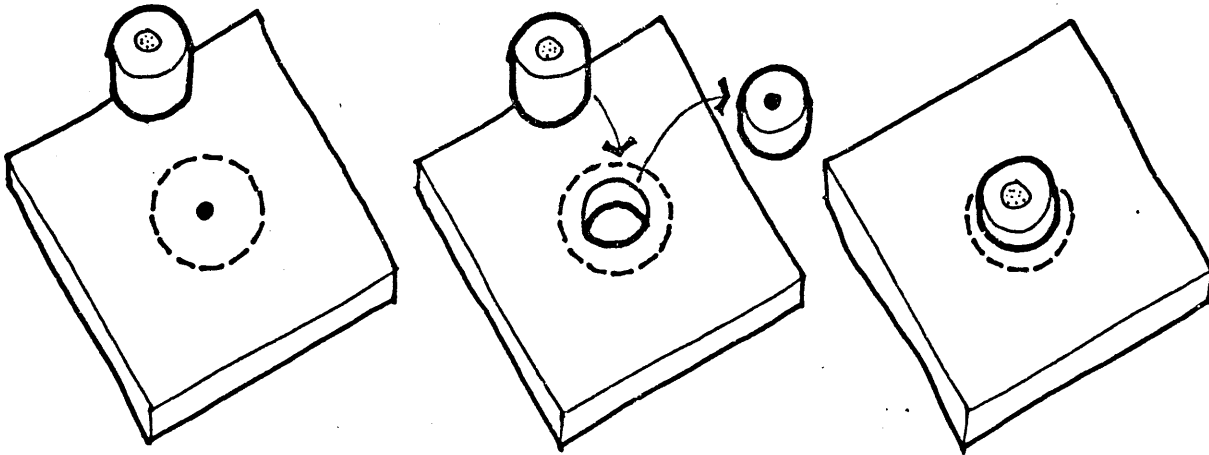

KENOSIS, or EMPTYING-AND-REFILLING.

Here the artist puts forward a more radical proposition in which he says, "What the predecessor really meant was this." That is, he reinterprets the locus of meaning itself--in spatial terms, removing the locus of which the predecessor's work was an elaboration and replacing it with the new locus that his new work elaborates. The predecessor-work thus comes to seem irrelevant.

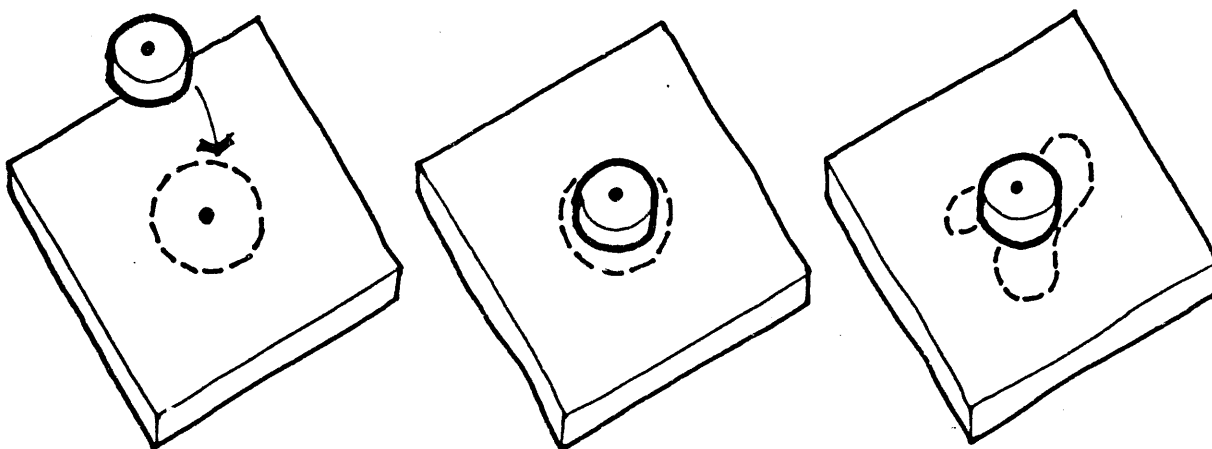

DAEMONIZATION, which might be termed FOCUSING. In this case the new work

appears on the scene and the older work comes to seem wandering, out-of-focus-- the new work now seen as incisive, on-target.

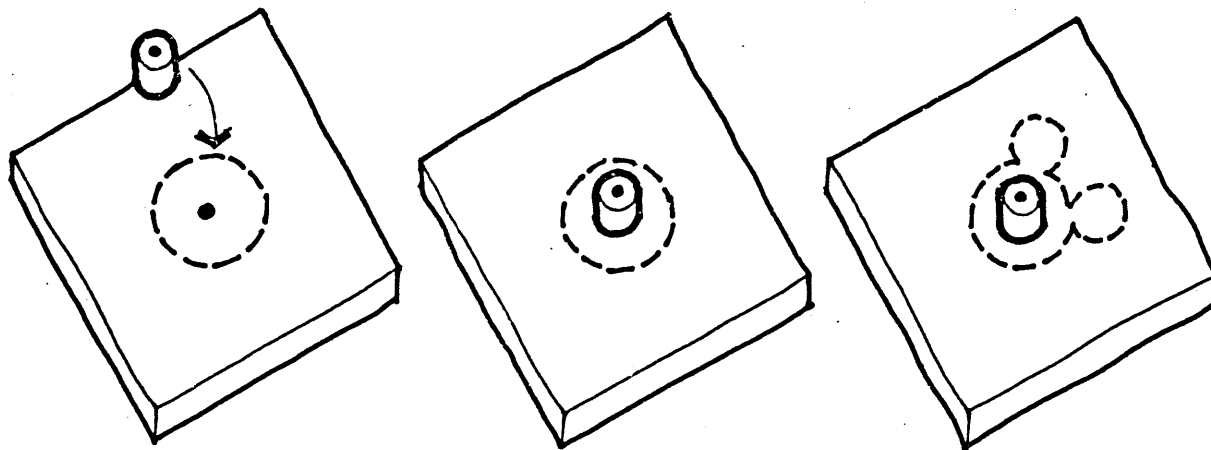

ASKESIS, or SELF-LIMITATION. Here the artist deliberately limits his development of the locus of meaning but "sells" this diminished elaboration as sufficient and complete--with the result that the older work comes to be seen as having needless, superfluous elements.

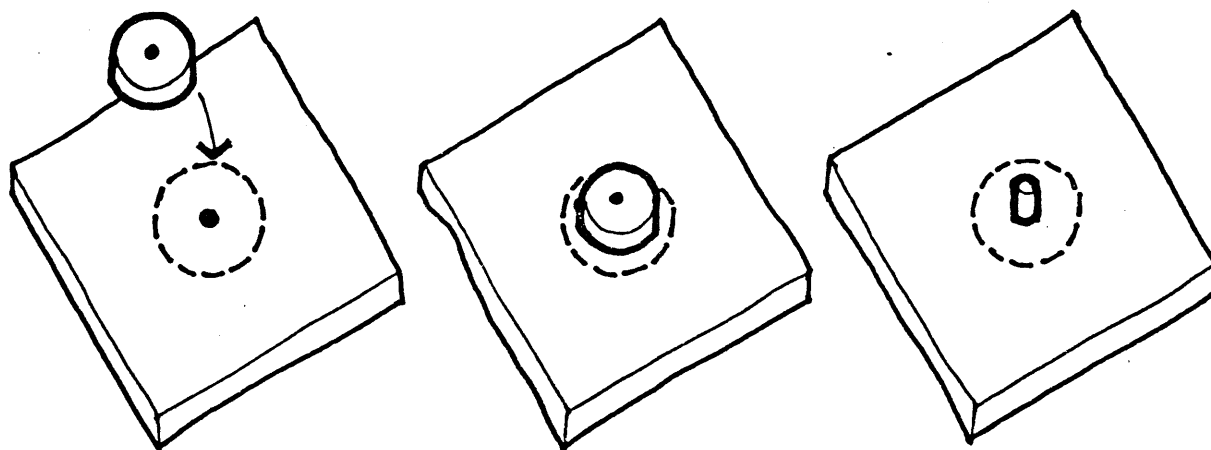

APOPHRADES, which I have termed BECOMING THE ESSENCE. This is the most radical proposition of all, for here the new work is seen to embody the locus of meaning so perfectly as to become that locus: the

\*Bloom's model thus can deal with the phenomenon of revivals without the pejorative "throw-back" characterization which the linear model must invoke to account for such occurrences within the terms of its system.

resulting effect is that the older work, as a development of that locus, now comes to be seen as no more than an elaboration upon its successor.

Bloom's vision thus overturns the idea of temporal succession--an idea that, because of its quality of linearity (of having two ends) so often leads to the dangers of extending the line either forward (the projected future as the inevitable result of the present) or back (the present as the inevitable result of a constructed past). By allowing one to map temporal relationships into space, Bloom's system avoids the problem of determinacy but still provides a rigorous model for change--a type of change that is unpredictable but which is more than just random occurrences. And also, by showing succession as spatial, Bloom's model addresses the known condition of artistic reevaluation: for in the model of linear succession, the only work to which a new work is directly related is the one immediately behind it on the line: relations between the new work and ones more distantly-previous have to be modelled by some leap-frogging process. Bloom's model, however, avoids this, the new work being placed directly atop the work to which it is compared.\*

But the consideration that makes this model most applicable to my personal vision of architecture is the notion of the equivalence of works from different points in time. For this vision, it seems to me,

accords most precisely with the normal perception and use of buildings in the environment--much better than the analytical view that sees a building primarily in terms of what came before and after it. In a very real sense, Bloom's vision frees the work from its position on a time-line, allowing it to interact with the works of all times and places; and in so doing, he frees the viewer from the single vision of linear succession--allowing him the freedom to reinterpret the relations of history and the standards of quality--but all and only within the elastically-defined but strictly-enforced bounds of the discursive plane of architecture.

For me, this Bloom/Foucault system is almost uncontrollably suggestive, but let me present some of these implications in a structured framework. In the next section, labelled Opportunities, I will try to show how the compositional ideal that flows out of this system opens up opportunities foreclosed by the more conventional ideal based on the tenets of the modern movement.



# Opportunities

Let me return to my interpretation of Bloom's system: recall how each work was centered on a point that denoted the focus of a net of relationships; as such, any sum-of-qualities or "essence" that a work might be said to have would consist of the interpretation of those relationships. Thus, under this model, a work has no "essence" intrinsic to itself; and further (since these relationships are to works of other times) a work has no meaning apart from its history.

Stated in this bald manner, this assertion flies in the face of (an equally bald version of) the conventional modern-architecture ideal, which would state that any "essence" a building might have would flow from its unique and individual manner of reflecting the specific reality of the present moment. This specific reality would be defined in terms of individual functional requirements, and (in extreme form) the design ideal would be: first, to find the specific form which most perfectly accommodated each particular function; by then arranging these individual function-fit forms according to their positions in a sequence of activities, a building would result that then could be said to be reflective of its functional order.

(This is admittedly an extreme form of the functionalist ideal, going beyond even Christopher Alexander's close-fit functionalism of the mid-sixties--a

\*And in the very same sense, to seek to interpret a building reflective of only a structural order (a Miesian universal space, for example) would be equally fatuous. The December 1975 issue of Architectural Review made much the same point about buildings reflective only of the "order of the market."

\*\*precisely "those simple signals that tell one how to function in a building" that I've sought to go beyond.

position which even he has now backed away from. And although the whole issue is something of a dead horse, I am not beating it to further defeat defeated functionalism, but instead to point out what I see as the necessary characteristics of an acceptable alternative.)

My objections to this ideal again come on two grounds--its implications for the way people actually live, and its implications for the operation of the system meant to model the way people live. On the level of daily life, this type of close-fit design necessarily works against any functional arrangements other than those foreseen and provided for; in fact, the closer it approaches its ideal of "perfect fit," the more it inhibits alternatives.

And in the terms of the system's reconstruction of public perception, another objection is that, by attempting to be an embodiment of only its functional order, this design ideal makes any contemplation after a wider, subsuming understanding fatuous: the designer intended no aphoristic vision of the building situation, and so to look for one would be futile and self-defeating.\* In other words, since the building is meant to reflect nothing more than the unique, empirical reality of its programmed functions, the only non-fatuous import one could derive from the building would be a knowledge of its (unique, empirical) physical layout.\*\*

But I think that the most revealing flaw is that the ideal simply does not model the way architects work: it posits a situation in which the architect ought to be "surprised" at the final (derived) configuration of his building. Here Bloom's is a more convincing reconstruction of the architect's actual efforts. For with Bloom's model the architect knows, before he puts pencil to paper, what position he wants his building to occupy; in other terms, he knows the nature of the desired relations to other buildings. He thus has a prevision of the import of his building--he knows beforehand what he wants it to "mean"--and he works to bring that import to form. This import is the precise parallel of the aphoristic design concept I spoke of earlier--the insight that doesn't merely explain the layout of the rooms, but which makes the conflicting aspects of the total building situation fall into place. Thus under this Bloom/Foucault model, and under my own, the architect works to have his building seen as a deliberate embodiment of his own resolution of the building situation.

This notion of working from a design preconception implies a manner of composition that also runs counter to the modern-architecture ideal. Under the functional ideal, the designer's base is a collection of specific parts, each form the result of an objective design process; under this alternative system

the designer begins with a general whole whose form is the result of an intensely subjective choice process: from among forms that already exist (and thus have import) the designer chooses the form that best embodies his design conception (and whose import will suggest that it be compared/related to a chosen predecessor). His design task (his "elaboration of the locus of meaning") then is to divide up that general whole to provide articulated, optionally-invoked spaces for the specific activities. But note: because the basic form of the whole would be one familiar to the viewer, it would not be necessary to see the form in an "unviolated" state in order to recognize its shape; thus the manifesting of specific parts would not foreclose the possibility of perceiving the whole's shape; but rather, these operations upon the whole would be seen as deviations from it--as distortions of the overall shape toward the individual shapes, moves from the general toward the specific.

Interestingly, this process closely parallels Louis Kahn's design method in which a general Form, reflective of the essence of the building, is distorted, through the process of Design, in response to particular, specific demands. But a further parallel might be said to exist with Beaux-Arts design methods, which not only stressed the unspecific articulation I've been promoting, but also employed previously-known forms

specifically for the purposes I've labelled positioning.

Both of these compositional methods can be seen as outgrowths of what Emil Kaufmann has termed the Renaissance-Baroque system of design.<sup>9</sup> Under this system too, general, known forms were articulated in response to specific needs, but Kaufmann points out that the ideal was to avoid overemphasis on either the whole or the parts by precisely balancing the antagonistic tendencies toward unity and division. This balance was achieved by composing the forms so that the relations between parts would always appear clear and unequivocal: wings would look clearly subordinate to the main mass; collections of potentially-repeatable items would be gathered so as to give an impression of "this much and no more" completeness; in windowed walls, either solid or void would dominate without question. These methods were carried forward and set down in compositional textbooks until well into the twentieth century.<sup>10</sup> But Kaufmann points out that the inherent flaws of the system were seen as early as the late eighteenth century: with the passing of Baroque absolutism, eventually the complexity of the patterns of activity to be housed reached a point where no form could adequately embody them; the tendency toward division began to dominate the compositions of the greatest architects, and the possibility of maintaining wholeness

\*This idea comes from a conversation with Peter Eisenman, but a similar idea is expressed in an article titled "Transparency, Literal and Phenomenal" by Colin Rowe and Robert Slutzky which appeared in Perspecta 8.

seemed to be lost.

But one can now see that the break-up of the system Kaufmann describes was not made inevitable by the increased complexity of the programs but by the insistence on unequivocal formal relations: by demanding that the relations between parts be viewed in one specific way, the compositional ideal foreclosed the possibility that, as in the Browne house, there could be more than one unified "embodiment" in the same building.\* The realization that such an embodiment is not an empirical fact but is a creation of the viewer's mind ties together several aspects. First, on the level of the viewer, it avoids the freedom-restricting insistence on a single "correct" set of formal relations and in so doing it allows the individual viewer to involve himself with the building. It is thus also a truer reflection of the way public perception itself changes over time (objects that look "slim" to most people in one decade might look "spindly" in the next).

For the designer this multiple-suggestiveness both allows for and encourages the deliberate misreading and positioning that were shown as a model for innovation. It is also the source of the lyricism of a building that continues to yield new interpretations. But for me, the greatest possibility opened up by multiple suggestiveness is that it can gently prod the ordinary viewer into contemplation: it

is too often the case that a person will look at a building, decide that it is unquestionably thus-and-so, and never really look at it again. Multiple suggestiveness could serve to undermine this closed-mindedness by presenting to the viewer things that cannot be explained in a single glance, things that ask to be studied more fully. But, crucially, not things that demand to be studied. And, equally crucially, things that will both justify and reward such study.

# Dangers

There must be literally dozens of ways that one could point out the potential dangers this system holds for theory and practice, and even to respond (in this pre-emptive manner) to just those I'm aware of would be more than either I or the reader could handle. So in this section I try to respond to only four of these topics, these particular ones chosen from among many possibilities for their ability to highlight and clarify certain aspects I consider important.

## L'ARCHITECTURE DANS LE BOUDOIR

The first involves the notion, discussed at the end of the last section, that the "architecture" aspects of a building are seen only when one employs a special kind of perception. Manfredo Tafuri<sup>11</sup> has used the term l'Architecture dans le boudoir to denote the phenomenon in which forms are deliberately disposed so as to make the viewer notice qualities that would not be seen by an everyday perception. He sees no possibility for explicit, "iconic" meaning in architecture today because of the nature of modern life; and so, he maintains, modern architects have attempted to recover meaning by redefining it in terms of qualities that can be conveyed by form. Tafuri describes two ways in which this project has been approached.

The first group (characterized by the work of Aldo Rossi in Italy, but to a lesser degree also by that of Kahn and Stirling) affirms the possibility of



recovering the kinesthetic, experiential import of forms themselves by a move of wrenching a particular form out of its normal (functional, economic) context: by minimizing the connection between a form and its use, the form is highlighted as an exceptional event (like the classic chairs on the platform at MoMA)--as, in fact, precisely surreal. Thus, once the viewer has been jarred into an awareness of the-form-itself, he begins to notice the (intrinsic) qualities he never saw before--qualities which this tendency would claim as the "meaning" of the form. In this view, the apperception of formal meaning depends on a separation from, or more precisely a denial of the context of the ordinary world.

The second tendency (illustrated perhaps best by the work of Ulrich Frantzen, the Smithsons or the Metabolist Group) can also be seen as an attempt to reciver meaning; but in this case meaning is seen as attached, not to specific forms, but to specific functions or actions. The basis for this notion is the observation that, while important human needs are relatively enduring, these needs are met by a succession of forms, each of which, in turn, fills the same cultural "slot," thus assuming the import, the meaning held by its predecessor. Consequently, this approach seeks to recapture meaning by introducing (as replacements for supposedly-obsolete forms) new forms that so clearly reflect or emphasize their

\*It is interesting to note how much this replacing process resembles that in which perceptions were seen as shifted on a discursive plane. The crucial difference, of course, is that a plane posited for this system would be one of use alone.

function that they take over the associations linked to the older forms.\*

This approach is likewise dans le boudoir in that, in this case, an activity is highlighted as exceptional by the unfamiliar form with which one performs the act (recall the first time you sat in a Barcelona chair): again, a heightened awareness depends on the creation of a surreal situation. And where the first case presented a situation in which the existence of the normal form-use tie is denied, here the artist opposes the link between an everyday activity and its normal accommodating form.

Tafuri sees both of these attempts at meaning as doomed to failure. His first criticism is that one cannot evaluate the products of either system: taking as his object-to-be-evaluated the disposition of the forms of a building, Tafuri points out that, with the first approach, the arrangement of forms is (to a greater or lesser extent) arbitrary, ordered according to rules set up by the architect and therefore criticizable only in terms of adherence to those same rules--which of course results only in a futile tautology. In the second group, the disposition of forms is proof against criticism because (in theory) it is determined by the functional requirements it satisfies. Seeing that criticism of either system circles back on itself, Tafuri maintains that one must get outside these systems of form and see what validity their respective

rules for arranging forms have when measured against the "structures that determine the existence of architecture." Tafuri maintains that these structures are the economy and the systems of industrial production, and that the rules of both groups exist only in relation to this order of production: the first, by adopting production's forms and rejecting their normal uses; the second, by adopting the use-patterns of the industrialized world but rejecting the forms with which the activities are normally carried out. Thus, says Tafuri, neither pole has an independent existence apart from production, and both therefore exist at the sufferance of the production system.

But this problem of captivity exists only if one assumes that "architecture" must be indisputably there: if, as I've tried to maintain, architecture itself is seen as not an empirical reality, nor even as a perception of an empirical reality, but as a subjective interpretation of perceived intentionality--then that architecture is a creation of the complicity between viewer and (interpreted) maker, a creation that is apart from the system of production. As for Tafuri's other objection--the absence of standards that exist outside the system--I've tried to show how structures like the law have standards that possess a complex relationship to the world outside the system, but that even without the grounding in public acceptability, these structures

can function in a perfectly rigorous manner if only they confine their operations to those areas within a boundary criterion.

For the realm of art, however, such self-imposed restrictions seem, at first glance, inappropriate. Art, one would imagine, would seek a different sort of base of validity; this next part will discuss three tendencies in modern art, each of which can be seen as a search for some kind of certitude. In this respect, all three might be seen as reflecting a certain lack of faith in the standards man adopts to judge his own works; this standard has always heretofore been some (changing) conception of a "human order," but doubt about the adequacy of this standard arises when one realizes that the same man-created human order has also been the principle used by man to guide his own creative efforts. All too aware of this situation, the modern sensibility seems to despair over the revealed conditional quality of all human creations, and one manifestation of this despair is this series of attempts to find a standard outside man--to find an order that is not man-made and consequently fallible.

#### AUTHENTICITY

The first tendency focuses on what Bloom referred to as the opacity of objects, the notion that an object created as a statement will be inauthentic to the conception of its maker. The

\*or, in the terms used in the model of the discursive plane, attention thus forecloses the type of associative positioning posited as the basis for interpretation.

realization of this in art has led to the ongoing project of producing objects free of this characteristic--producing objects that will be seen as unlike everyday objects-in-the-world. Rosalind Krauss has termed the desired mode of seeing these works as one of attention:<sup>12</sup> when one looks at an object with attention, one abandons his normal inclination to formulate a general impression of the total object by which he can classify it with other known objects. Instead, he focuses individually on each characteristic of the surface of the object so that each surface characteristic remains specific, and each is experienced only as itself--not as merely a component to be subsumed into some preconceived whole.

The object itself, then, must be of such a nature as to defeat the normal-perception tendency to generalize and meld individual characteristics into a prior and therefore inauthentic synthesis.\* Michael Fried has noted two basic ways in which this has been attempted,<sup>13</sup> both of which involve a manipulation of the relations between these individual characteristics. With Literalist art (under which Fried includes Minimal sculptures and paintings), the artist attempts to create a work in which the individual parts will manifest no relation to each other, but will relate only and directly to the whole. That is, by being prevented from logically forming any two

or more parts into a sub-group, one is forced to see the whole only as an assemblage of parts, each of which is perceived as only itself and therefore authentic to itself.

If Literalist art thus tries to defeat the normal making of relations by denying their possibility, then Modernist art makes the same attempt by proposing an alternative set of relations--those of art itself. For this art, the only object truly unlike everyday objects is an art-object--a work whose parts are related in a deliberate, conventional manner. The Modernist artist thus aims to prevent the viewer from forming an unintended (and therefore inauthentic) set of relations by making his (the artist's) own relations appear inevitable;<sup>14</sup> that is, that the disposition of parts will look so patently "right" that the viewer's attention will pass over the relations and focus instead only on the whole object, the object again seen as an assemblage of parts, but in this case parts related in the only logically possible (and therefore authentic) manner.

One can see that both tendencies deal with the issue of the relation of parts by attempting to close the matter to question--Literalist art by a non-existent relation between parts, Modernist by a relation seen as inevitable. What the correct perception of this art demands, then, is that the viewer suspend his everyday propensity to seek a reason that

would account for why the parts of an object are arranged in a particular way. Thus the intention is not only to prevent the viewer from imagining alternative relations, but also to prevent speculation as to why the one permissible configuration was give that particular form. Given this, the Literalist/Modernist model, if used in the creation of buildings, would not only prevent the reconceptualizations necessary for alternative uses, it would also prevent any complicity or involvement by the viewer.

This is a problem raised by applying a model where it perhaps cannot fit; but even on the level of art itself, objections can be raised. With either a Literalist or Modernist work, the viewer's feeling of being foreign to the artwork is a logical outcome of the artist's program of preventing the inauthenticity of the viewer's imagining that the work is like something seen before. In Clement Greenberg's view, the artwork distances the viewer, producing a situation which he terms presence.<sup>15</sup> But conversely (as Fried points out), presence exists only when a viewer is on hand;<sup>16</sup> without the viewer's reaction, that quality of presence by which the work seeks to defeat the inauthenticity of interpretation ceases to exist. In the absence of a viewer, the work loses a part of its fundamental nature: if presence is a necessary part of the artwork, then by itself the work is incomplete and

\*The work itself thus "tells" the viewer when his mode of perception is inapplicable--in much the same way that the fake storefronts "told" the viewer that looking at them as architecture would be fatuous.

so, inauthentic.

#### AUTONOMY

To escape this situation--which Fried calls theatricality--the work must, in some objective sense, be autonomous from its audience; that is, the work must defeat speculation by being such that the only things that could possibly be known about it are those things that would be apprehended by a purely objective perceiving mechanism--by eyesight alone. Fried maintains that this condition can exist only when the artwork is "wholly manifest" in an instant<sup>17</sup>--when successive viewings of the work would supply no additional data for use in (subjective) speculation after a "content." Thus, the inauthenticity of a theatrical, speculative situation is defeated only when the viewer realizes that the objective, eyesight data he gets upon first seeing the work is all the data one could possibly get. If he tries to make speculations that involve characteristics of form beyond those immediately presented to vision, these speculations will be shown to be false because the work will supply no "corroborating data."\* One can see how this quality is achieved in the paintings of Morris Louis and Kenneth Noland, but Krauss has pointed to David Smith's sculpture as an example of the more difficult project of making three-dimensional forms "wholly manifest."<sup>18</sup>--which of course immediately suggests that this method might be applicable to a



possible architecture. For like architecture, a sculpture is necessarily experienced sequentially: that is, an impression is formed upon first seeing the work against which successive impressions from other points are compared. By the way he configures his work, Smith insures that views beyond the first will either "look like some object other than the one I first saw" or else "look like exactly and only the object I first saw." That is, all that can be known about a work is seen immediately, since additional views will only provide contradictory information or the same information. Smith's work is thus authentic to the opaque nature of objects because the work really does "say" or imply no import beyond what one can see. But Krauss notes that by so doing, Smith's work also achieves seamlessness in that one's views of the work, being "always different" or "always the same," are undifferentiated from each other and thus indivisible.

Again one can see how in this way a perfectly permissible condition in art becomes a stumbling-block when applied to architecture, for this indivisibility would (if achieved) prevent one from imagining the sub-groups of parts necessary to accommodate activities. But also once again--as in the case of the phenomenon of presence--considerations from within the realm of art itself point up objections to the project of manifesting forms that "say nothing." This goal of

\*in Bloom's terms,  
an ASKESIS.

producing only silence can be seen as a self-restriction\* by the artist, as a faithfulness to Wittgenstein's doctrine of refusing to say those things which cannot be stated clearly. Silence, then, can be seen as a denoting by the artist of those areas of life to which verbalizing is inadequate and inauthentic. And so by implication, the area of life covered by the artist is just such an area "of which one must remain silent." Seen in these terms, the task of preventing speculation beyond the surface qualities of his work can be thought of as an effort by the artist to retain his role as "truthful commentator" on his chosen area of experience by insuring that his works will not be read incorrectly and judged untruthful. Susan Sontag has characterized this refusal to speak as the marking of artistic space: by clearing away the "noise" of unjustified speculation and unclear thought, what is left is pure, true silence. But here again, she points out, the artist's autonomy is defeated by the very fact that his created silence can be perceived only because the rest of the world is so noisy.<sup>19</sup> The artistic space is seen as different and therefore distinct not for its own intrinsic qualities, but only because it opposes what surrounds it: like the architecture dans le bouroir, the silent space depends upon the world because it exists only in relation to it.

## THE NATURE OF THE MEDIUM

There is a third tendency in modern art which could be seen as an attempt to circumvent these problems of existing in opposition to objective reality: by clearing away all conventions, this tendency tries to base an art on the incontrovertible imperatives that make up the unique nature of each medium. The major outcome of this idea has been the attempt to found an esthetics of painting upon only the quality of flatness. Neil Levine has pointed out that, almost alone among all the arts, hardly any discussion occurred about a unique nature of architecture; he himself has suggested the intriguing idea that one might consider the essential characteristic of architecture to be the bounding surface;<sup>20</sup> that is, unlike the surface of a painting, which essentially has no other side, and unlike the surface of a sculpture, which is touched by the same space on all sides, the surface of an architectural object is always touched by one space on one side ("a room") but by a space that is essentially different on any other side ("a different room," the outdoors). But whatever one settles on as the nature of a medium, each proposition can be seen as an attempt to redefine the nature of the medium--inevitably to propose an alternative vision of that particular art. To do so necessarily implies a belief that the existent vision of the art is in some

way misdirected, bankrupt, or false.

Now, the system I'm trying to construct is also an alternative vision, and it too springs from a belief in the bankruptcy of the modernist vision. But I have already revealed my fondness for aphorisms, and I think there are multiple layers of meaning in Benedetto Croce's motto "Architecture is what everybody knows it is."<sup>21</sup> If architecture has a unique nature as an art is must be that exists for people in the world. To found an architecture on terms other than this is necessarily to be false, inauthentic. Rather than attempt to redefine architecture, I have tried to accept "what everybody knows" about architecture and systematize it. Some of the possible fruits of this approach are discussed in the final section.

# Possibilities

In this final section I want to discuss two possibilities raised by the material presented thus far. These possibilities are speculative, of course, but more than mere flights of fancy: much of the reasoning for this analytical method is based on the two quite different analytical systems constructed by Susan Sontag and Claude Levi-Strauss, and these possibilities are similarly based on implications the authors noted for their own systems.

The idea that one might be able to reconstruct the found logic of a social phenomenon comes from Levi-Strauss' analysis of Indian myths of Latin America,<sup>22</sup> in which (in a way quite different from that which I've employed) he posits a structure that encompasses all the myths into a rigorous system. The logic of this structure is not the same as that the natives use to explain the myths to themselves, but is rather a reconstruction of that logic along other, quite different lines.

But what Levi-Strauss found in the construction of this system was that, by, in effect, getting outside the system and looking back at it (through the "lens" of his own systematic model), one could glimpse there a "Great Truth," an interpreted import to the system itself.\* And, like the "import" of an architect's design conception, this Great Truth would take the form of a many-layered, subsuming aphorism--one that would explain

\*In Foucault's terms one would view the whole system as a dot on some plane of human experience; this import would thus consist of the interpreted relations that myth (as a system) has with the rest of life.

\*Or: the interpreted import of the individual myths according to the logic of the participants: the myths' relation on one of the participants' discursive planes.

the system in the "Aha!" way referred to before. For example, Edmund Leach<sup>23</sup> has pointed out that one studying the whole of Greek myth along the lines of Levi-Strauss' American studies might interpret their import as "Sons must kill their fathers, and daughters must desert their homes"--a rather curious statement and one that, at first glance, also flies in the face of the social lessons taught by the individual myths.\* But by considering the statement in an aphoristic way, one can see that the society of docile children called for by the individual myths would be one doomed eventually to stagnation: only when children do turn against their parents will a culture remain vigorous. The subsuming Truth, then, suggests that, for the everyday conduct of affairs, children should be pliant and well-behaved, but for the long-term health of society they must be rebellious.

The tantalizing implication this holds for my study is that a thorough-going reconstruction of the found system of architecture might likewise reveal a similar aphoristic insight. This is, of course, highly speculative, but it does suggest that any study that seeks to derive an essential nature of architecture from its material reality may be misdirected, focusing on a picture as incomplete as the individual Greek myths; better, perhaps, and more fruitful to focus on what architecture means to the

\*This esthetics, like my reconstruction, would be a modelling of one of the many possible existent ways of seeing.

public.

The second point, in fact, concerns itself directly with this question of what meaning architecture holds for people. The preceding section raised the possibility that received theories of art be considered bankrupt on their own terms; Susan Sontag's criticism<sup>24</sup> addresses the more fundamental issue of their meaninglessness and lack of relevance to the lives of people. She appeals for an art that will make us more attuned to the world--to make us "sense more"--and for a criticism that will help us do so. She sees a vicious cycle in which the public loses the ability to respond to art and the artist ceases to produce works that could engender a response. This is due, she says, to a fundamentally miscast vision of what art does and how it does it. To address this misapprehension, she sketches the outlines of an esthetics\* and moves on to describe the necessary function of criticism under such a system.

Her central point is that the insight one gains through the experiencing of art is fundamentally different from that kind of insight one might learn or be taught: through art one experiences a "way of making sense of things." This is a crucial phrase: one experiences, one does not "learn" or "come to know;" and as such, one's words could never fully describe such an experience which, like an aphorism, would have multiple levels

\*This assumes, as I think one must, that one cannot imagine a wholly new form--that one necessarily begins work from the base of a prior form.

\*\*in two senses: to impute aphoristic meaning to every part of the configuration would be fatuous; conversely, to assume that each part is the result of only functional (mechanically-derived, unwilled) considerations and to explain the work only in those terms would not only be exploitative, but would fail to provide any guide to apprehending the places where volition was manifested.

of significance. By the same token, then, criticism could never convey the quality of this experience to a viewer: criticism cannot explain art to the public--what it must do is guide the viewer toward having his own personal experience of art.

For Sontag, criticism, as presently conceived, fails to recognize this task because it misunderstands the nature of artistic form. Criticism takes as its object the actual physical configuration of the work and tries to disclose the import of that configuration--the reason why all the forms are arranged as they are. But (for Sontag) the artistic purpose of an art work is not to convey import (not to "teach") but to convey the artist's volition. Thus (in my terms) the artist's task is to bring a physical configuration of forms into accord with his deliberate, resolved vision. In essence, the artist intervenes in that configuration\* only at those points that do not accord with that vision; that is, the final configuration discloses the points at which the artist deliberately chose to intervene--where he prevented "the fortuitous" from appearing by interposing "the intentional."

The function of criticism, then, is not to interpret the whole of the physical configuration itself,\*\* but to separate those aspects that are intentional from those that are merely fortuitous: to point out those places where the configuration differs from "what would have



happened if no will had intervened." By so doing, criticism reveals the pattern of intentionality manifested within the forms. The viewer then interprets that pattern and in so doing experiences the aphoristic insight: or, in Foucault's terms, he relates and compares that pattern with other remembered patterns, the configuration of these connections being a function of the viewer's experiences, but the nature of each connection constituting one of the insight's many layers of meaning.

Thus, though one could never fully describe the personal import of such an experience, one can say that its character is one of association, a linking of immediate experience with memory. By this linking, memory gives immediate experience a profounder import, and in return immediate experience both renews (and adds to) memory and connects it to the present. Memory is thus seen as not merely a repository of tid-bits to be turned to at odd moments, but as an ever-present source of deep meaning.

In like fashion, innovation can be seen in a new light: an innovative work would not be simply a work whose specific shape had not been seen before, but would be a work whose deliberate aspects (whatever shape they took) revealed a new way to convey a pattern of volition. By perceiving an innovative work in these terms, a viewer would apprehend a new way in which the associative experience could be

"triggered." But more: because the multiple connections made by the insight need not be limited to memories only from that particular artistic medium, each new experience opens the viewer to the possibility of associating that pattern of volition with remembered patterns from other areas of life. Once one fully realizes this, one sees that it is possible to perform any act according to a deliberate pattern that deviates from the fortuitous, and it is possible to link any deliberate, patterned act with any other deliberate, patterned act.

The realization of this distinction between willed acts and fortuitous acts is central: one can, in fact, see an historical analog here. In traditional or archaic societies, (nearly) all the forms and actions of the culture are controlled or specified by an all-embracing canon: every action is either in conformance to a rule (and therefore meaningful) or in violation of one (and therefore also meaningful). But with the break-up of traditional society and the emergence of individual freedom comes the possibility not only of willed or intentional form and action, but also of fortuitous (and therefore meaningless) form and action. Thus one might say that a bargain is struck: with freedom comes the ability and power to act according to one's own will, but with fortuitousness comes the atomization and confusion of meaningless forms and inexplicable actions.

For the realm of art, freedom makes innovation possible, but fortuitousness raises the need for a criticism that will attune us to the difference between volition and accident.

By pointing out places in life where there is deliberate import, such a criticism would dispel the stultifying suspicion that all forms and acts are meaningless. Opened in this way to new possibilities, a viewer who gave his complicity to an intentional act would experience associations that would forge links to other actions, from different times and from other areas of life. By showing us these links, art would provide a vision of a re-integrated life, a vision that suggests a new aphorism: Art explains life, life imitates art.

## Notes

1. Mariana Griswold VanRensselaer, Henry Hobson Richardson and his Works (1969), pp. 105-6.

2. Jean Piaget, Main Trends in Interdisciplinary Research (1973).

3. Many thinkers in the field of the philosophy of science have explored the relation between data-collection and data-interpretation, among the ones who have influenced this model are:

Imre Lakatos, "Falsification and the Methodology of Scientific Research Programmes" in I. Lakatos and A. Musgrave, eds., Criticism and the Growth of Knowledge (1970).

Karl Popper, "On the Sources of Ignorance and knowledge" in Conjectures and Refutations: the Growth of Scientific Knowledge (1968).

Joseph Agassi, Towards a Historiography of Science (1963).

4. Michel Foucault, The Archaeology of Knowledge (1972).

5. Michel Foucault, I, Pierre Riviere... (1975).

6. Ted Morgan, "New! Improved! Advertising!" New York Times Magazine, 25 January 1976.

7. This extremely cursory version of the law's structure is distilled from the following standard texts:

Benjamin Cardozo, The Nature of the Judicial Process (1921).

Edward H. Levi, An Introduction to Legal Reasoning (1949).

And one rebuttal:

Richard Dworkin, "The Model of Rules," University of Chicago Law Review (1967), pp. 17-45.

The idea of using the law as a model--one of the ideas that tickled my mind into beginning this study--comes from:

Peter Collins, Architectural Judgement (1971).

8. Harold Bloom, The Anxiety of Influence (1973).

My introduction to Bloom's ideas came through:

Vincent Scully, The Shingle Style Today; or, the Historian's Revenge (1974).

9. Emil Kaufmann, Architecture in the Age of Reason (1955).

10. Some of these books include:

N. C. Curtis, Architectural Composition (1908).

H. Robertson, Principles of Architectural Composition (1924).

Ernest Pickering, Architectural Design (1933).  
 A. Trystan Edwards, Style and Composition in Architecture (1952).

11. Manfredo Tafuri, "L'Architecture dans le boudoir: The Language of Criticism and the Criticism of Language," Oppositions 3.

12. Rosalind Krauss, Terminal Iron Works: The Sculpture of David Smith (1971), p. 99.

13. Michael Fried, "Art and Objecthood," Artforum 5 (summer, 1967).

14. Michael Fried, Three American Painters (exhibition catalog, 1965), p. 44.

15. Fried, "Art...", p. 13.

16. Ibid., p. 15.

17. Ibid., p. 17.

18. Krauss, p. 181.

19. Susan Sontag, "The Aesthetics of Silence" in Styles of Radical Will (1969).

20. Neil Levine, conversation, 2 March 1976.

21. Quoted by Sibyl Moholy-Nagy at a symposium in Charlottesville, Va., December 1968.

22. This account of Levi-Strauss' work is based primarily on my reading of his The Raw and the Cooked (1970).

23. Edmund Leach, Claude Levi-Strauss (1974).

24. My interpretation of Sontag is based on two of her essays, "Against Interpretation" and "On Style," both in her Against Interpretation (1966).