

TG (TRANSIT GUIDANCE): Spaces for Wayfinding in Multi-modal Transportation Hubs, a Proposal for Atlanta's Lenox Station

by Steven Jackson

Bachelor of Science (Architecture)
Georgia Institute of Technology
Atlanta, GA June 1996

Submitted to the Department of Architecture in partial fulfillment of the requirements for the degree of Master of Architecture at the Massachusetts Institute of Technology, February 2002

Signature of Author: _____

Steven Jackson
Department of Architecture
January 18, 2002

Certified by: _____

Paul Lukez
Assistant Professor of Architecture
Thesis Supervisor

Accepted by: _____

Andrew Scott
Associate Professor of Architecture
Chairman, Department Committee on Graduate Students

© 2002 Steven Jackson. All rights reserved. The author hereby grants to MIT permission to reproduce and to distribute publicly paper and electronic copies of this thesis document in whole or in part.

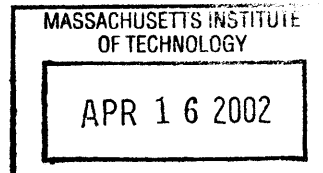

ROTCH



THESIS READERS

John de Monchaux
Professor of Architecture and Planning

John Fernandez
Assistant Professor of Architectural Design and
Building Technology

Nico Kienzl
DDES candidate, Harvard Graduate School of
Design



TG (TRANSIT GUIDANCE): Spaces for Wayfinding in Multi-modal Transportation Hubs, a Proposal for Atlanta's Lenox Station

by Steven Jackson

ABSTRACT

3

Submitted to the Department of Architecture on January 18, 2002 in Partial Fulfillment of the Requirements for the Degree of Master of Architecture

"The efficiency of the city and therefore the contribution of urbanization to development will depend to an important degree on how the problems of mobility are resolved."

Wilfred Owen (1972)

Thesis Supervisor: Paul Lukez
Title: Assistant Professor of Architecture

Based on current urban patterns, this thesis assumes that as cities continue to expand and densify, living and working environments will increasingly be attracted to edge-city sites with access to public multi-modal transportation infrastructure. The program required to accommodate efficient interchange to/from and within such infrastructure (involving trains, buses, shuttles, taxis, cars, bicycles, etc) is both vast and complex. It is critical to urban mobility that the architecture of such spaces facilitates wayfinding at both an urban and inner-station scales. Unfortunately, many existing transportation interchanges that are supposed to unify, actually contribute to division through inefficient program and through illegible spaces that rely solely on signage for orientation rather than architecture. TRANSIT GUIDANCE is a set of design propositions as well as an implementation that demonstrates how architecture can be used to heighten users' environmental understanding in and around edge-city multimodal transit stations, thereby facilitating efficient navigation and ultimately the collective mental image of the city.

ACKNOWLEDGEMENTS

To God- for being the ultimate designer and providing me with whatever ability I have.

To my family- Mom, Dad, David, and Katherine- for last minute text editing, for constant encouragement and for making my studies possible. I would not be what I am today without each of you.

To MIT and the Rosenberg Travel Scholarship Fund for the opportunity to travel and study some of the greatest transportation stations in the world.

To my committee- for unusually strong commitment to teaching and for being extremely generous with your time, despite extremely busy schedules of your own. Specifically to my advisor Paul Lukez for creative design comments, for enabling me to study in Delft, and for exposure to several of my present urban interests, to my readers- John de Monchaux for always knowing the right thing to say at the right time and for encouraging me to always hold true to the core of my idea, to John Fernandez for Structural Morphologies and for two years of excellent, rigorous intellectual and design support, and to Nico Kienzl for great enthusiasm for my work and for clear, precise design criticism. Also to Ann Pendleton Julian and to Bill Porter for brief but lucid comments at key points before and during the thesis semester.

To the MArch staff- for familiarity, friendliness, and being so helpful.

To the thesis students of 7-401 for exceptionally good times over the last two and a half years- I hope there will be many more to come. Specifically to LBQ³ (Lena Matthew, Lora Kim, and Amina Razvi) for helpful design critique and cheerleading (on and off the basketball court), to "DJ" Nat Skerry, Edwin Lau and Amina Razvi for

answering (without annoyance) my incessant software questions, and to Manan Shah and Joe Ho for Form-Z guidance and last-minute presentation help.

To my thesis buddies- Sean Kwok, Joe Schollemeyer, Ian Frasier, Kenneth Namkung, Keiko Sugeta, Jason Hart, Pam Campbell, Hyung-Suk Lee, and Kyun-Soo Nam- for last minute presentation help.



TABLE OF CONTENTS

abstract	3
acknowledgements	4
1 WAYFINDING	
1.1 Wayfinding Defined	12
1.2 Cognition: The Fundamental Mechanism in Wayfinding	13
1.3 Environmental Features Useful in Wayfinding	17
1.4 Wayfinding Research in Transportation Environments	20
1.5 Current Wayfinding Needs for Collective Transit	22
1.6 TRANSIT GUIDANCE: Wayfinding objectives for collective transportation	26
2 DESIGN PROPOSITIONS	
2.1 Europe research	31
2.2 General Considerations	34
2.3 Urban scale	38
2.4 Architectural Scale: Spatial Perception	42
2.5 Architectural Scale: Visual Access	48
2.6 Primary Propositions	55
3 SITE SELECTION	
3.1 Primary Site Conditions	59
3.2 Relevant Cities for Exploration	59
3.3 Atlanta	61
3.4 Lenox	63
3.5 Site Analysis	65



Figure 1 - Canary Wharf Station

4 DESIGN EXPLORATION	
4.1 Programmatic Assumptions	72
4.2 Design Process	74
4.3 Design Decisions	75
4.4 Final Design	80
5 FINDINGS AND CONCLUSIONS	
5.1 Personal Comments	102
5.2 Primary Urban Propositions	103
5.3 Primary Spatial Perception Propositions	104
5.4 Primary Visual Access Propositions	105
5.5 Findings and Conclusions	106
bibliography	110
figure credits	114

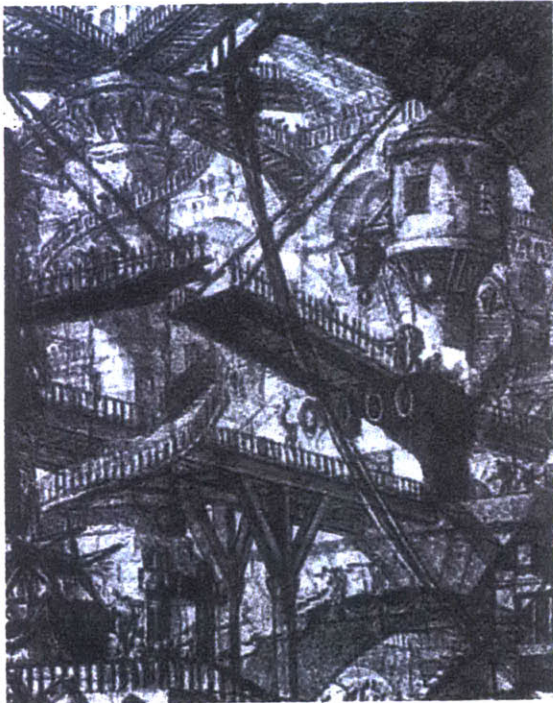
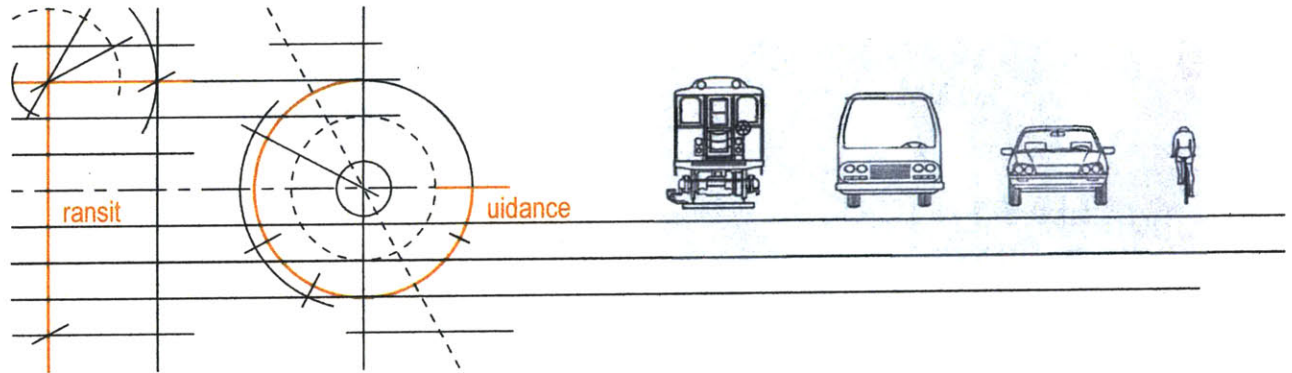

Figure 2 - *Invenzioni capric di Carceri*, Giovanni Battista Piranesi, 1760. A shadowy world of constant movement.

"Nothing was left but the pillars that bore the colossal vaults. Nothing was left but darkness exorcised, a scab of stones split open to the putrefying gloom. Through it showed the crucial instruments of systematic terror, the spiked shafts and iron in ordered lunacy. Through it, all the architecture of the shadows showed, the catwalks ending in empty space and men smashed. Through it showed weight, and force, the secrets of the machinery of power discovered and stripped down to the bedrock. That was all it was. Some palace steps, a labyrinth of silence none dared speak in, the multiple structure created to putrify each man with each"

(Seghers, 1993).

CHAPTER ONE: WAYFINDING



1. The first part of the document discusses the importance of maintaining accurate records of all transactions. It emphasizes that proper record-keeping is essential for the integrity of the financial system and for the ability to detect and prevent fraud. The document also notes that records should be kept for a sufficient period of time to allow for a thorough audit.

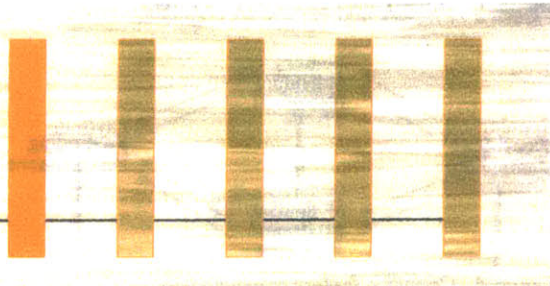

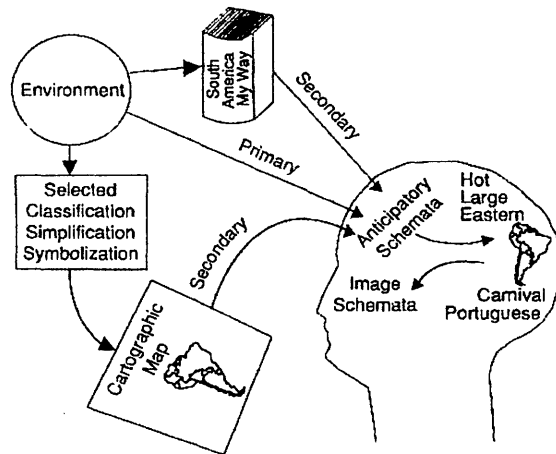

Figure 3 - Primary and secondary cognition

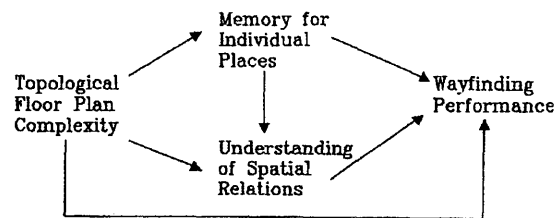

Figure 4 - Cognitive factors in wayfinding

1.1 Wayfinding Defined

One of the most troubling experiences we can face is being lost. When this occurs, help from those things we depend upon the most- technology, other people, and our own abilities to process and store information- provide us with no aid. In extreme situations, this can threaten our very survival. While being truly lost is rare, newcomers commonly experience the stress and anxiety associated with disorientation in natural environments as well as buildings (e.g., Cohen et al., 1986; Hunt, 1984). For some, this stress may be particularly grievous, even life-threatening (Hunt, 1984).

According to Siedel, "Wayfinding generally has been viewed by researchers as an individual's negotiating his or her way through a physical environment to a specified destination" (Siedel, 1982). Kevin Lynch elaborates on this, defining wayfinding as "The process of [comprehending] the environmental image, the generalized mental picture of the exterior world that is held by the individual" (Lynch, 1960). He goes on to say how important this is to urban inhabitants. A clear image allows one to navigate an environment quicker and with greater ease of movement. A well-ordered, vivid environment can reinforce this image by establishing a legible system or framework on which a user can organize his or her activities, beliefs, and knowledge. In this way it acts as a basis for personal growth. An imageable environment can also facilitate social interaction by establishing "symbols and collective memories of group communication" (Lynch 1960). Also, a good environmental image helps users to feel more emotionally and even physically secure. Finally, a clear image leads to a

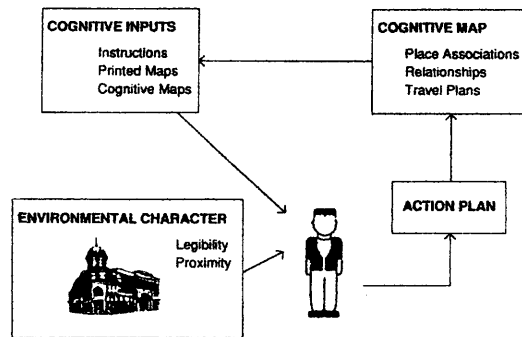

Figure 5 - An informal model of spatial cognition. Instructions from other humans, printed maps, and memories of past travels help an individual form an action plan for proposed journey. The success or failure of this plan as it is carried out becomes stored in memory and leads to place associations, future travel plans, and an evolving cognition map for future reference.

deeper human experience.

1.2 Cognition: The Fundamental Mechanism in Wayfinding

The essence of wayfinding is environmental cognition, or the “ability or propensity to imagine and think about the spatial world” (Bell et al. 1996). This mental function allows us to perceive, store, alter and use the complex array of information available in the environment. This yields cognitive maps, which are “a very personal representation of the familiar environment that we all experience” (Bell et al. 1996). Cognitive maps are very closely tied to the process of wayfinding and understanding them is useful for explaining wayfinding and for determining how navigable an environment is.

There are numerous theories of how we form cognitive maps. Perhaps the most established is Stephen Kaplan’s, which proposes that the cognitive process begins with object recognition. This includes the ability to recognize objects, anticipate, abstract, generalize, and ultimately leads to innovation and problem solving. Kaplan suggests that through object recognition, bits of information are gathered called cues. These are the building blocks for a cognitive map. Gradually, these cues accumulate to form an organized mental structure so that new cues can be added with much more ease and precision than the original ones. Eventually, the structure develops enough to relate to a known pattern or object in the environment (Kaplan, 1976).

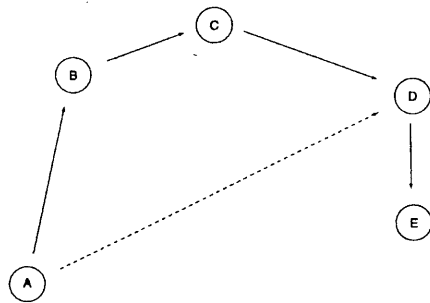

Figure 6 - The solid line indicates the routes a person has traveled between five landmarks, the dashed line represents a shortcut that may be possible if a cognitive map is already present.

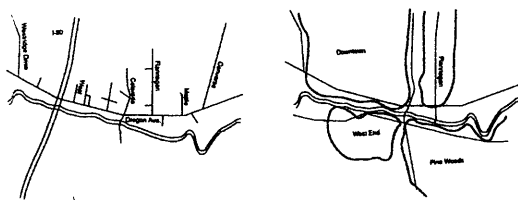

Figure 7 - different examples of cognitive maps (sequential on left, spatial on right)

It is currently thought that our cognitive maps or environmental images are mentally represented through a combination of analog representation and propositional storage (Bell et al., 1996). Analog representation is more concrete, and is essentially a mental picture, which corresponds directly to the physical environment (e.g., Cornodoli & McDaniel, 1991; Glicksohn, 1994; Kosslyn, 1975). Propositional storage is more abstract, being composed of concepts that are connected to other concepts through associations like height, color, name and sound (Anderson and Bower, 1973; Pylyshyn, 1973, 1981).

When people are aware of objects, those objects can be comprehended as they relate to space and time. This allows for the ability of anticipation. One learns through experience that objects or events may be understood and expected to occur spatially or temporally near or with certain other objects or events. These sequences allow the cognitive mechanism to formulate object and event representations and the cognitive map that connects them.

Kaplan suggests that there is hierarchy of cognitive maps. The initial layer is made up of directly sensed objects. These are detailed and clear. Higher layers become more vague and lack information. The degree of variation one has in filling in those missing bits of information allows for the abilities of generalization and abstraction. The lower, more complete, layers contain information such as dogcc or Atlanta. The higher, less complete layers hold concept such as building or city.



Figure 8 - People tend to overestimate the size of familiar areas, as is demonstrated in this humorous example.



Figure 9 - A nonperpendicular intersection in a small town that is remembered as perpendicular.

The next step is innovation or problem solving, which comes into play when a new situation is encountered. In this case, an unprecedented event or object arises. A meaningful sequence must be synthesized. This requires that the problem or starting point and the solution or goal must be represented in the cognitive system and the cognitive map searched for a connection between the two. If a direct connection cannot be located, one can still be found indirectly through a series of sub-goals that already exist in the map.

Wayfinding, the bridge between stored mental images or facts and actual environmental behavior (Bell et al., 1996), is such a search of the cognitive map. If the experience is a new one, it is still likely to contain elements of a typical wayfinding experience and some of which may already be stored in one's cognitive map.

It is also believed (Stea, 1976) that cognitive mapping abilities must be acquired. It is proposed that in children, such activity originates by the brain's left hemisphere, controlling language, writing and other non-dimensional processes. As a child develops, the cognitive mapping role shifts to the brain's right hemisphere, the side that is believed to control perception, fantasy, spatial knowledge and other dimensional processes. This extent to which this shift occurs is influenced by such factors as the child's social role, formal education and environmental experience.

As with developing a cognitive map, there are two theories that are most widely used to describe

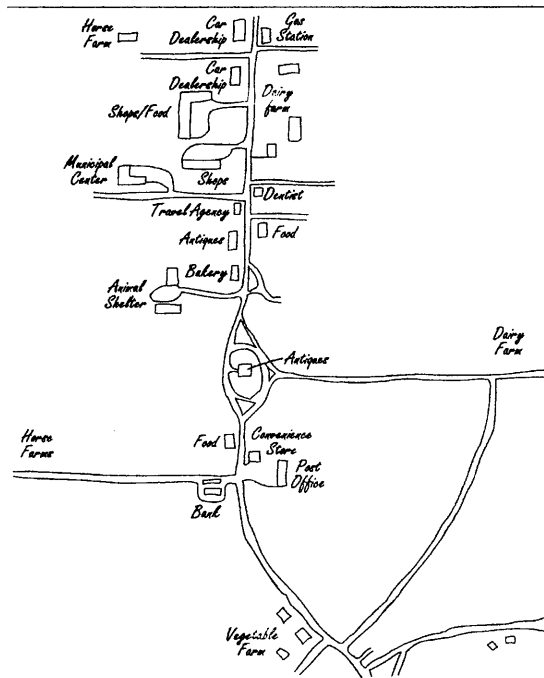

Figure 10 - A student's sketch map of her hometown.

how we wayfind. Gärland (1986) proposed one which is heavily grounded in analog representation, involving four major decisions. First, we determine a destination. Second, a new target destination must be localized. Third, a route is chosen. Finally, a choice of travel mode must be made, based on factors such as distance to the destination and the availability of transportation. This theory emphasizes an internal process that enables us to anticipate a scenario through mental rehearsal.

Passini (1984) offers the other most popular understanding of wayfinding behavior, which is more grounded in the notion of propositional storage. He suggests that wayfinding is essentially a sequence of problem-solving tasks that builds on stored environmental information. Instead of recalling a cognitive map, one first may only need to recognize a specific environmental feature such as a landmark. Second, wayfinding is self-correcting, allowing for the capability to correct misjudgments.

Byrne (1979) suggests that successful wayfinding may simply require a network map that preserves only the connections between steps of a journey. This may be true, but it seems logical that having a more developed cognitive map would allow one to navigate more efficiently. Wayfinding success is most certainly dependent upon a combination of how developed our cognitive maps are, and how well we anticipate and problem-solve as we navigate our environments. We may never know for sure exactly how wayfinding works, but understanding its known characteristics is a useful foundation for developing an architecture to facilitate it.

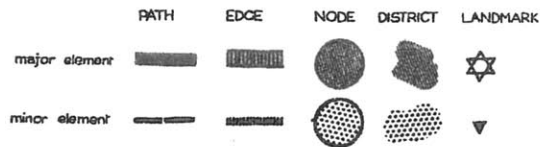

Figure 11 - Lynch's elements developed to analyze imageability of urban environments

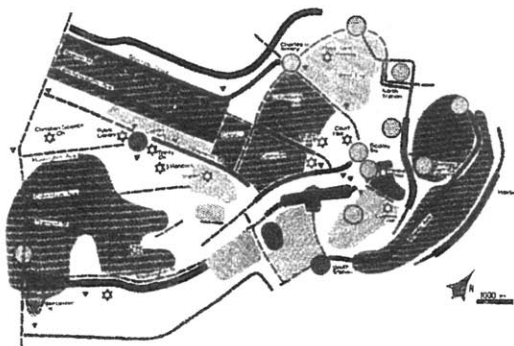

Figure 12 - Example of Lynch's urban environmental analysis technique applied to Boston

1.3 Environmental Features Useful in Wayfinding

In his wayfinding research in the three cities of Boston, Jersey City, and Los Angeles, Lynch (1960) developed a system of five elements that work together to influence how we move through cities. They are paths, edges, districts, nodes, and landmarks. Paths are shared corridors such as streets, walkways, riverways, transit lines or railways. Edges are limited or enclosing features that tend to be linear but are not functioning as paths. Districts are larger spaces of the cognitive maps that have some common character such as the "Chinatown" found in many cities. Nodes are major points where behavior is focused, typically associated with the intersection of major paths or places where paths are terminated or broken, such as a downtown square or the interchange between two freeways. Landmarks are simply points or objects of reference and can occur at many different scales. Even today, these elements are an important basis for research in environmental perception (Aragones & Arredondo, 1985; Evans, 1980).

The perception of these features varies, depending upon one's cultural background. To someone from a suburban area that is totally dependent upon a car, a freeway might be seen as a path. To someone from an urban area who walks more frequently, the same freeway might be seen as a barrier (Rapport, 1976).

Paths and nodes have been found to be perceived first in the navigation process (Lynch, 1960; Devlin, 1976). They are usually learned very quickly and then form the basic structure that the cogni-

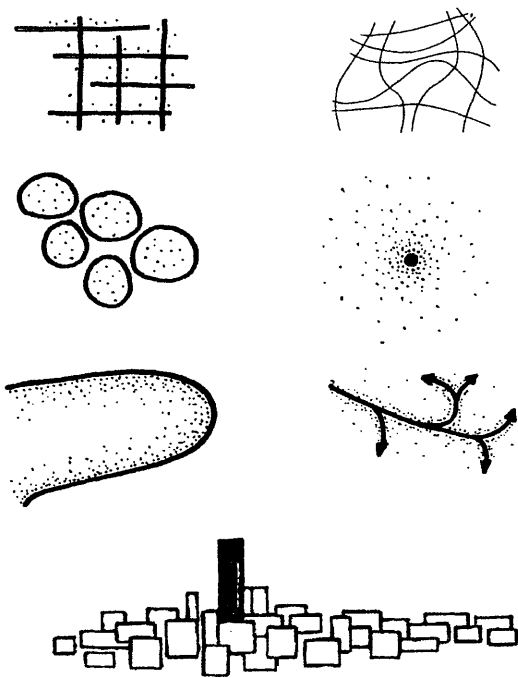

Figure 13 - Some of Lynch's diagrams used to understand urban navigation

tive map is built upon. In the early stages, there are often significant distortions in how these features are remembered. Lynch (1960) discovered that paths of irregular shape are often remembered as being regular while subtle curves or bends in paths may not be remembered at all. Nodes do not need a strong physical form to be remembered, but it does make them more recognizable.

Lynch (1960) also found that landmarks were increasingly used for navigation as people became more familiar with a journey. He also found that those who knew their city well tended to use smaller landmarks for navigation while newcomers tended to use larger landmarks that were noticeable from a great distance. In general, singularity (or uniqueness), clarity of form, and contrast with background are the qualities that are most conducive to making a landmark identifiable. Devlin (1976) expands this notion by suggesting the concept of the functional landmark. In this case, the landmark is understood by its use to the individual, such as an often-visited gas station.

Perceptual access is also an important factor in wayfinding. Perceptual access is the degree of orientation facilitated by being able to see through a building or out of the building to the larger environment (Beck, 1983). This enables the individual to navigate based on reality rather than an abstract cognitive map. Preferably, the architecture provides visual access to the entire space from as many points as possible. However, even when the final destination cannot be seen, intermediate landmarks can be organized in a way that facilitates wayfinding (Weisman, 1979).

Weisman (1979) discusses how building form can facilitate wayfinding. The number of decision



Figure 14 - Quincy Market, an urban node that profited from Lynch's application of cognitive mapping research

points, corridor segments, and overall building symmetry are useful criteria. In general, a "good" building form is legible, simple, and facilitates wayfinding behavior. There needs to be a balance though. An "L" shaped plan may be simpler in some ways than a cross plan, but the cross plan may allow a better understanding of the overall building because more choices and destinations are visible from the intersection. Whatever the case, buildings as well as urban environments tend to be perceived in an overly simplistic, regularized way. Street segments that extend from intersections in slightly different directions tend to be perceived as perfectly straight. Buildings with five sides may be thought of as having only four, and a corridor that ends may be remembered as a thoroughfare (Weisman, 1979).

19

Kaplan (1976) identified the importance of generic or collective information to wayfinding. This is environmental information that is understood without actually having been experienced. In the natural environment, this could mean knowing locations of certain types of plant life. In an urban context, it could be knowledge that the courthouse is near the police station. In a building, this could mean knowing where the elevator cores are located. It is important that architecture have an organization that makes generic information clear, whether through direct visual access or through other, less direct means.

Signage can work together with architecture to orient individuals. Its effectiveness is dependent upon its design, location, and context. Weisman (1979) points out the importance hierarchy in a

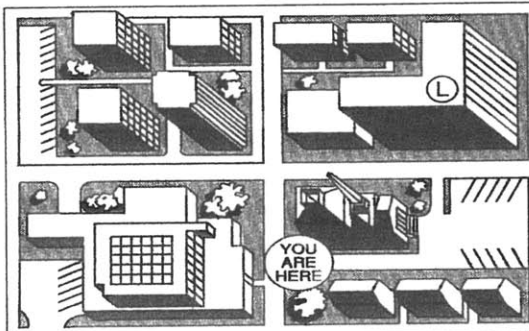

Figure 15 - Structure matching in you-are-here maps. In this map, labels and caricature map symbols allow the user to match the map with the surrounding terrain.

signage system. For instance, a sign to an electrical closet should not be of equal importance as a sign to an emergency stairwell exit or auditorium. Cantilli and Fruin (1972) also note that due to short-term memory, signage information should be kept short and familiar, and they should be displayed relatively frequently.

While some signage is generally necessary for wayfinding, it is important to point out some of its limitations. In legible architectural environments, users being researched have shown a tendency to consult a uniformed official or member of the public over a sign. This might be due to past experience with unreliable posted information or simply skepticism that the information is current (Canter, 1977). Also, individuals in complex, dynamic situations like a crowded movie theater foyer will often seek an official over signage because (1) the environment may appear too complex, (2) there may be much more information than one is able to assimilate, (3) a person may not wish to make an error and seem foolish, and (4) it is simpler to ask a person than to figure out a situation of oneself (Stilz, 1970).

1.4 Wayfinding Research in Transportation Environments

Designing legible spaces can be critical in transportation environments. Research has shown that pedestrian in transportation terminals, who are more likely to be anxious about meeting a plane or train schedule have more of a tendency to become confused and disoriented (Fruin, 1971). This

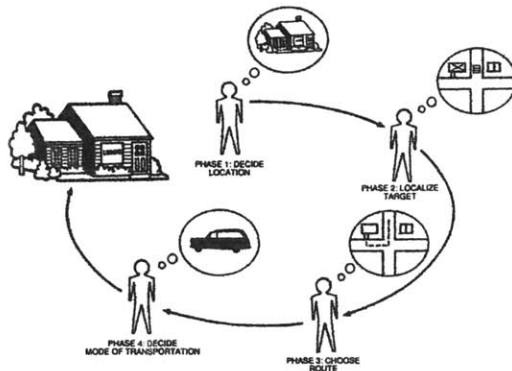

Figure 16 - Wayfinding. A hypothetical example of a trip to receive one's laundry.

can even threaten safety in transit stations, where pausing or expressing confusion, uncertainty, or frustration can make someone a potential target for a criminal incident (Hoel, Richards, 1980).

Frequency of use clearly aids wayfinding and the ability to give directions in transportation stations. Seidel's study at Dallas-Fort Worth Airport (1982) indicates that there is a threshold at which users feel lost. It follows that this threshold is based on travel experience in a particular transit environment as well as overall transit experience.

Bronzaft, Dobrow, and O'Hanlon (1976) found that many of the New York subway spaces were illegible to users. It was unclear to them how the parts, stations, and routes were connected. As a result, users became dependent upon non-architectural information such as subway maps and announcements. Because this information was not considered satisfactory by many of the users, they often decided to navigate based on their own limited experience. As a result, they often chose to take inefficient routes rather than risk following a map that they did not trust.

In a study of the subway systems for Washington DC, and Atlanta, Robert Beck (1983) found at an architectural scale, four causes of wayfinding errors. The first was station symmetry. Because there was not enough architectural differentiation between different entrances at symmetric stations, users often mistakenly chose the opposite entrance for their destination and either backtracked or in some cases, actually got on the wrong train. Second, signage was poorly located or presented in a way

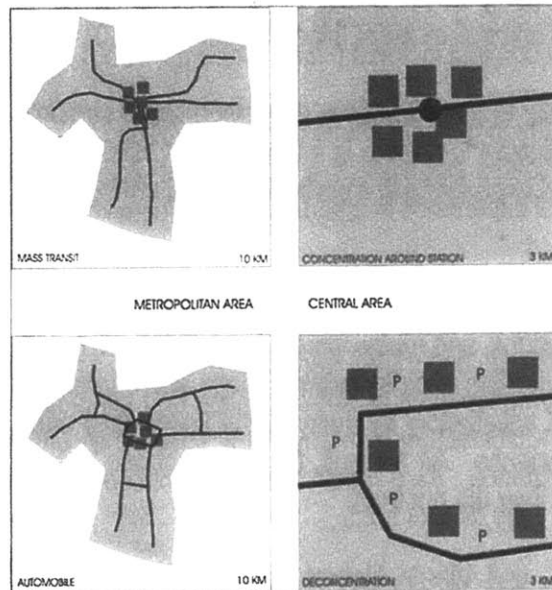

Figure 17 - Diagrams showing how urban concentration develops differently around automobile transportation and mass transit

that was hard to understand. The third cause of user error was perceived versus actual station symmetry. This was a combination of architecture, route density, and destination choices that led users to believe the spaces were easier to navigate than they really were. The final factor was perceived security. Factors such as system age, cleanliness, and perceived crime reputation led some users to make hasty navigational decisions that were incorrect.

Other research has indicated patterns of movement within transit stations. One study found that users tended to cluster around benches, columns, and train platform entry (Winkel, 1971). In studying the London Underground, Stilitz (1970) found that people in a busy ticket space tended to be attracted to certain elements such as doors, gates, newsstands, and notice boards. Frequently, the crowd traffic flow dictated where users could move or stand. People desiring information often would hover in dense crowds of waiting people. In general, there was a desire for individuals to locate themselves in places that were good for seeing and being seen.

1.5 Current Wayfinding Needs for Collective Transportation

Joel Garreau defines "edge city" as "Any place that [1] has five million square feet or more of leasable office space- the workplace of the information age, [2] has 600,000 square feet or more of leasable retail space, [3] has more jobs than bedrooms, [4] is perceived by the population as one place, [5] was nothing like 'city' as recently as thirty years ago" (Garreau, 1990). There has been a trend

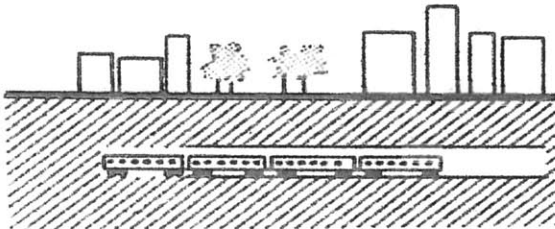

Figure 18 - Many transit stations have spaces that are completely buried, leading to urban detachment

in the last few decades, particularly in newer cities, to decentralize, shifting much of the focus of activity away from the traditional downtowns to edge-city highway infrastructure sites (Gordon 1996; Richardson 1988; Cortie 1994) with the characteristics identified by Garreau. In the process, parking and highways have clearly diluted much of the traditional notions of public space. These high-speed roads and acres of asphalt, which become eyesores, now fracture the mainstreets and sidewalks in these areas that traditionally helped to establish a tangible flow of public space. There is currently a need for wayfinding improvement in these areas through appropriate architectural and urban design responses.

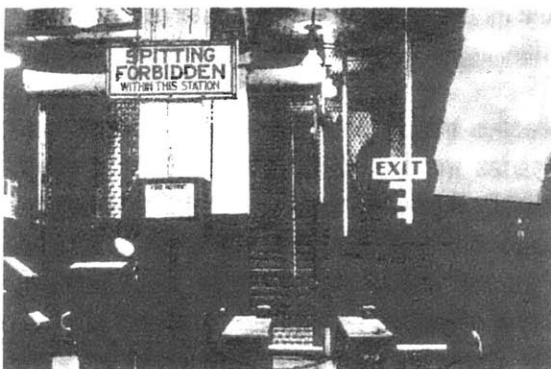
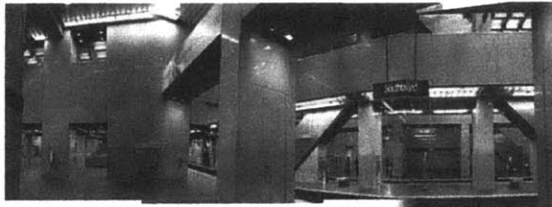

Figure 19 - The subway, described by Lynch as the "netherworld"

Many cities are increasingly moving towards edge-city conditions. Atlanta is such a city. Richard Dagenhart (1995) describes Atlanta and cities like it as "half-cities" because the only thing permanent is their intangible movement and vitality. He writes that "the highway, the parking lot, the bridge and the mall are the new public spaces in cities like Atlanta. These sites may be the location for constructing a visible city to accompany the beauty of an invisible metropolis." Traditional, centralized cities like Paris and London successfully use a system of public spaces composed of plazas, major promenades, and wide sidewalks to help organize the city. These spaces serve as wayfinding aids, acting as places for users to stop, slow down and take in the urban environment. At the same time, they often support many public activities, helping people to strengthen their cognitive maps of the area through activity. Increasing demand for collective transit to these edge-city conditions indicates that multi-modal hubs are an emerging new public space, potentially with qualities similar



Spaces in Atlanta's Five Points Station, the intersection of the two major MARTA subway lines in the city. Interior navigation is difficult due to signage clutter, and lack of visual landmarks in the architecture.

to Dagenhart's "invisible metropolis". As these stations begin to develop, there is a need that they be designed in a way that goes farther than just contributing the intangible, "invisible metropolis". They should also find new ways to establish more permanent, tangible, and memorable places that express the identity of these new areas, much in the same way as traditional streets and plazas do in centralized cities.

Also on an urban scale, collective transportation itself is a need that if met, can strengthen the collective mental image of the city. For the minority who do not have the luxury of an automobile, it is vital, serving as the only realistic means of accessing and building an environmental image to certain areas of the city. For those with access to an individual mode, using collective transit reinforces the city image by providing an alternative means of experiencing it.

On a community scale, this thesis assumes that collective transportation stations will be increasingly needed on edge-city sites. Over the past few decades, many edge-cities have emerged, which are decentralized densities of collective activities generally organized around a major road system (Jacobs, 2000). These activities typically include residential, mall, and other business programs. These kinds of sites promise to have a growing need for multi-modal stations in the years to come. Marc Jacobs notes that the most significant features of a collective transit station site are physical and temporal concentration of activity (Jacobs, 2000). These are also characteristics of edge-city sites, and particularly when these sites are along roads that are primary to urban circulation (such as



Figure 20 - A confusing Atlanta highway intersection known as "Spaghetti Junction".

perimeter highway rings), they are strong candidates for collective transit stations. As Ryan Gravel writes, "infrastructure supports density, density supports transit, and transit relieves traffic congestion" (Gravel, 1999). It follows that relieving traffic congestion is supportive of wayfinding because it makes navigation easier, more attractive, and ultimately more memorable, thus facilitating community wayfinding.

25

Also, particularly on edge-city site conditions, there exists a tension between individual modes, collective modes, and landscape. While almost everyone prefers the freedom of navigation associated with the car, it presently is the result of a great deal of congestion in edge-city nodes. Accommodating Individual Mode transport through parking and roads does seem necessary to justify the architecture of a multi-modal station. However, parking designs often are not sensitive to wayfinding in multi-modal hubs, as they often create large, dark, confusing, and sometime dangerous spaces, leading to diminished use. Also, in moderately dense urban contexts, parking generally is located in an off-site deck, which tends to be difficult to reach, or directly on site, which often leads to the perception of too much landscape segmentation, and becoming a barrier to natural urban flows.

Finally, at an architectural scale, most collective transportation spaces are not very conducive to wayfinding. While analyzing Boston's metro stations, Lynch (1960) wrote of how useful a thorough study of the imageability of transit systems in general would be, saying that so many transportation spaces are hard to relate structurally to the ground above them" and at their worst are "utterly direc-

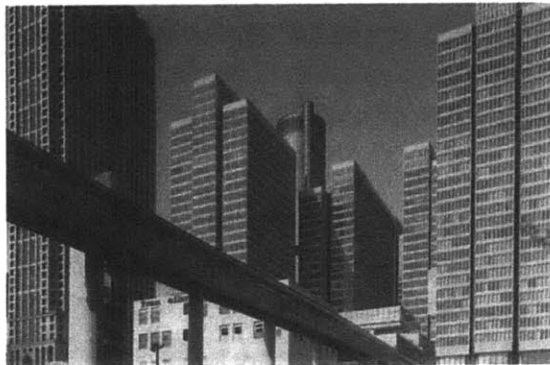

Figure 21 - Transportation line in downtown Atlanta

tionless" (Lynch, 1960). Beck (1983) elaborates saying how many stations are characterized by tight, small spaces obscured by forests of support columns, low ceilings cluttered with exposed structure, conduits and plumbing and a multitude of passageways snaking their way under the streets." In addition, these spaces generally have little or no natural light and have many niches and corners that can conceal crime. These architectural problems still flourish today in much of our transportation infrastructure and are a particular hindrance to wayfinding.

1.6 TRANSIT GUIDANCE: Wayfinding Objectives for Collective Transportation

On a network scale, this thesis hopes to show how transit stations can aid wayfinding by establishing a new network of public spaces that serve to organize the city at decentralized locations. Another such goal is to demonstrate how these stations can reinforce users' collective mental urban image, by appropriately building upon existing infrastructure that people may already know. In order for this act of building to be positive, it will need to both support and strengthen such existing infrastructure. A final network objective is to show how the city image can be served through the transportation network by establishing a better understanding of exterior site conditions from within it.

On a community scale, this thesis hopes to demonstrate how a station can orient by becoming a landmark, making itself and its program legible from many perspectives at an urban distance. It also seeks at this scale to show how existing transportation infrastructure that presently fractures a site



can stitch it back together. In doing so, it hopes to facilitate wayfinding by improving local circulation patterns and relieving traffic congestion. A final objective at this scale is to show how a transit station can organize a community by reinforcing the nodal patterns of an edge-city site.

27

On a building scale, this thesis seeks to support wayfinding through spaces, circulation paths, and modal relationships (primarily between trains, buses, cars, and pedestrians) that are as efficient and legible as possible. To this end, the thesis will explore how orientation within and around a station can be facilitated through visual and perceptual means. Another architectural goal is to show how public space can help to organize a multi-modal transit facility to establish unique and memorable places. On a similar note, this thesis hopes to support wayfinding by establish an architectural language for a multi-modal transit facilities that is attractive with comfortable, inviting spaces.

CHAPTER TWO: DESIGN PROPOSITIONS

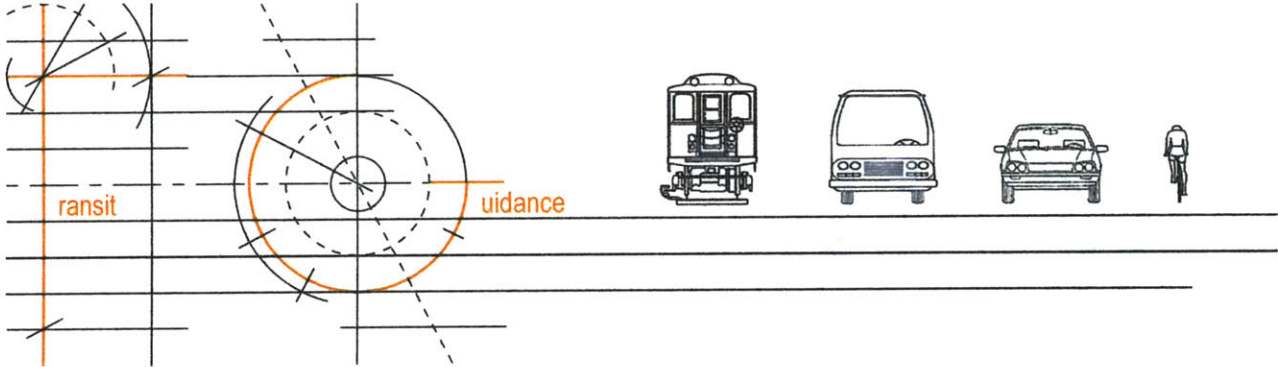
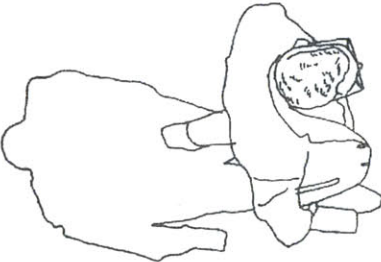

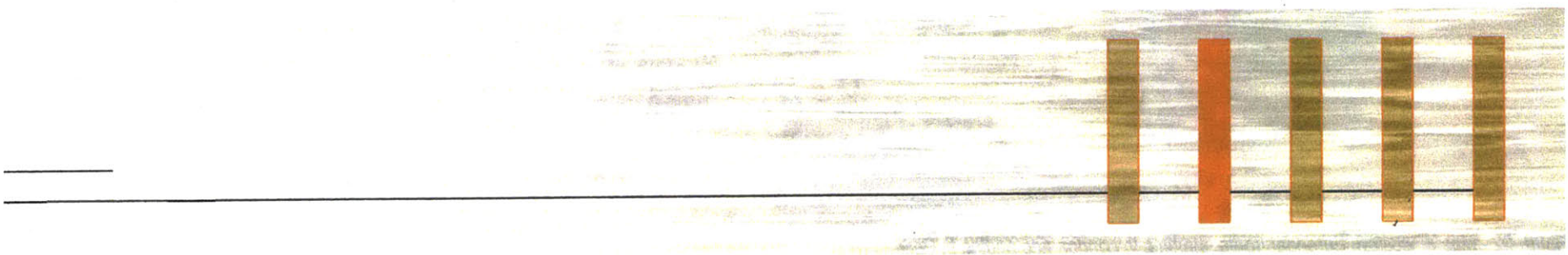

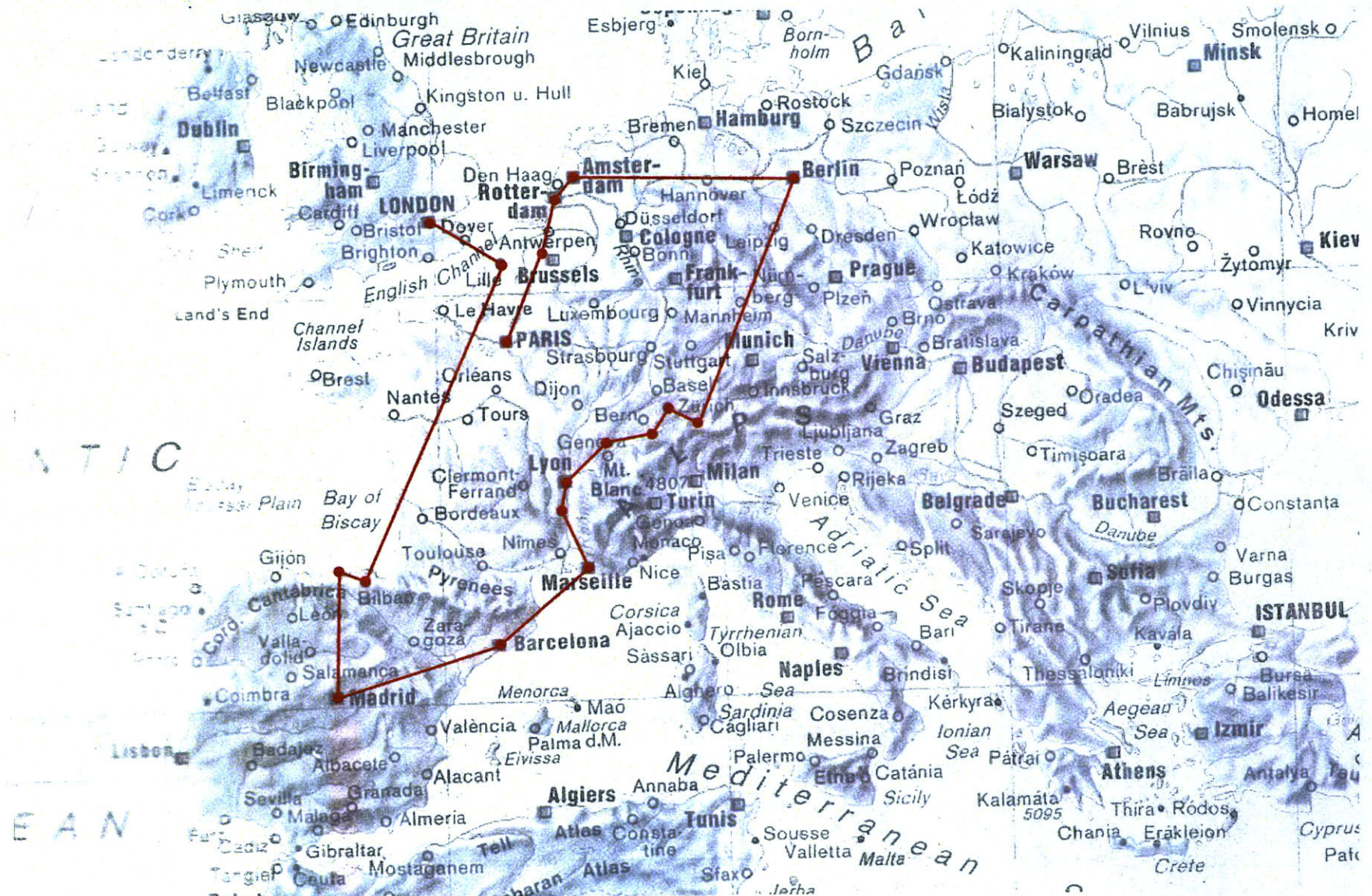
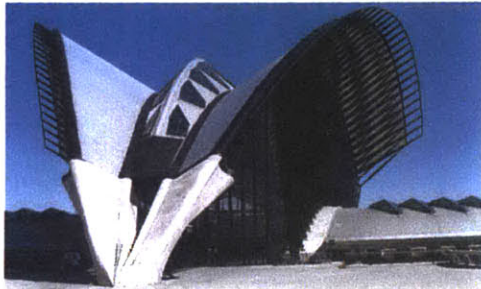

Figure 22 - Map of western European route, starting in London and ending in Paris

2.1 Europe Research

31

With the help of the Rosenberg Fellowship, I was able to build upon previous transportation wayfinding research (see section 1.4) by visiting and studying several successful, modern transportation stations in Western Europe during the summer prior to the thesis. This area has an extremely developed transportation network and probably more significant modern transportation stations than any similarly sized region in the world. One of major goals of this study was to glean a relatively extensive set of architectural design principles that could help solve the problems associated with disorientation in transportation spaces. The design propositions in this section are the result. They are certainly not exhaustive, but do cover most of the significant elements that I perceived to be successful wayfinding strategies in the stations visited. Each proposition is an abstraction of real conditions on a specific site. Their strength must reside in how well they can be translated into different specific contexts. This will be explored later.



Satolas Station



Chur Station



Canary Wharf Station

32



St. Lazare Station



Euralille Station



Schipol Airport Station



Ostbahnhof Station



Atocha Station



Stade de France Station



Avignon Station

DESIGN PROPOSITIONS



Bilbao Abando Station



Satolas Station



Westminster Station

The following is a list of some of the more influential stations visited:

33

Waterloo Station (London)
Stratford Station (near London)
Canning Town Station (near London)
Canada Water Station (London)
Canary Wharf (London)
Euralille Complex Metro (Lille)
Euralille TGV Station (Lille)
Bilbao Abando (Bilbao)
Atochia Station (Milan)
Avignon TGV Station (Avignon)
Satolas TGV Station (Lyon)
Interface Flon Railway Station (Lausanne)
Zurich Central Station (Zurich)
Stadelhofen Station (Zurich)
Chur Station (Switzerland)
Ostbahnhof Station (Berlin)
Alexanderplatz Station (Berlin)
Schipol Airport Station (Amsterdam)
Rotterdam CS (Rotterdam)
Liege Guillemins Railway Station (Liege)

St. Lazare Station (Paris)
Montparnasse Station (Paris)
TGV Station, Charles de Gaulle Airport (Paris)
Gare du Nord (Paris)
Chessy-Marne-la-Vallée (near Paris)
Versailles-Chantiers (near Paris)



Satolas Station

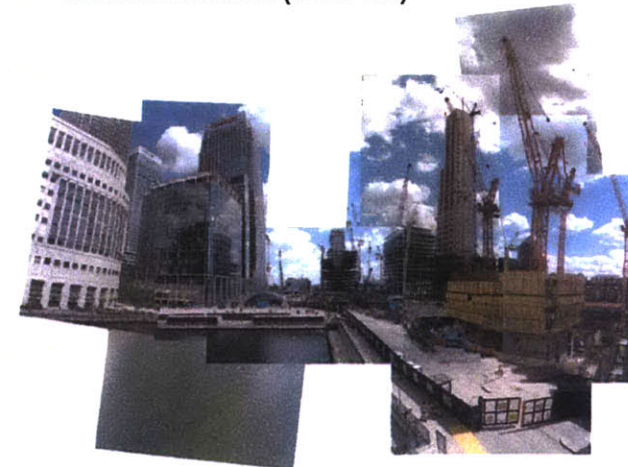

Canary Wharf



St. Lazare Station



Satolas Station



Canary Wharf Station

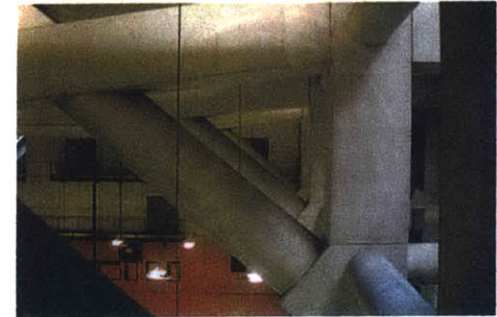

St. Lazare Station

2.2 General Considerations

The following considerations are all general criteria for the success of wayfinding in multi-modal transportation hubs. They are based on a combination of literature research, the European studies, and common sense. While for the most part, they are not specific enough for the designer to translate directly into architecture, they should be considered throughout the design process.

(i) Station should function efficiently

(ii) Layout should be easy for users to describe to others
Navigation should require an economy of mental effort

(iii) Station should be imageable from a distance (optic scale) as well as from within (haptic scale)

(iv) Station should establish a sense of balance and well being in users

(v) Station should respond to as many sensory cues as possible, focusing primarily on visual ones such as color, shape, motion, and polarization of light. Other sensory cues such as sound, touch, kinesthesia, and sense of gravity should be considered as well.

(vi) While views of entire station from all areas may not be possible, a legibility of the overall architecture and building organization system should be exist throughout. "An illegible environment is a setting in which the

{ figure text goes here }

DESIGN PROPOSITIONS



Bilbao Station

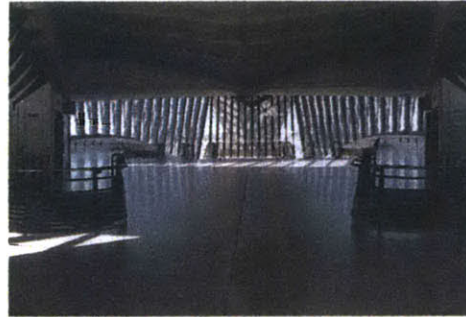

Satolas Station



Canada Water Station

parts cannot be easily recognized nor organized into a coherent pattern" (Lynch, 1960).

35

(vii) Station architecture should be memorable, emphasizing uniqueness of different major modal and transition domains, while still maintaining an overall consistent organization system.

(viii) Architecture should respond sensitively to its surrounding site conditions while clearly establishing itself as a station from an urban scale. "If a tall building is unmistakable in the city-wide panorama yet unrecognizable from its base, then a chance has been lost to pin together the images at two different levels of organization" (Lynch 1960).

(ix) Signage should be used sparingly with precision, allowing the architecture to orient as much as possible

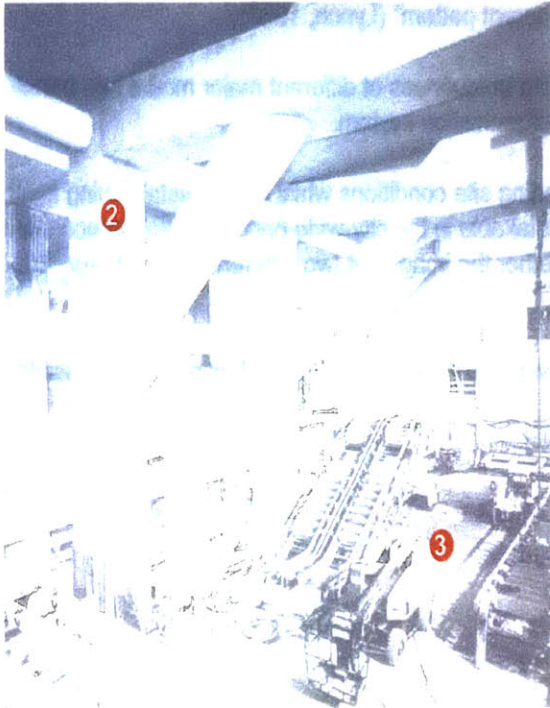
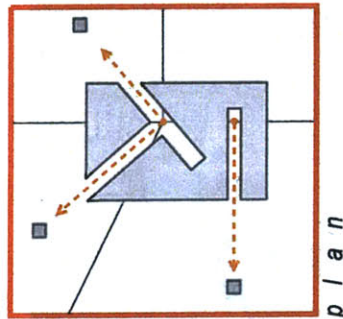

Figure 23 - St. Lazare Station; Paris, France; Agence des Gares/ AREP

2.3 Urban Scale

DP-1 Establish understanding of exterior context from within station. Where possible, stations should allow broad views of the city outside of the station. When this is not possible (generally where overhead conditions are too complex), they should at least provide clues to the exterior conditions. "The subway is a disconnected netherworld, and it is intriguing to speculate what means might be used to mesh it into the structure of the whole" (Lynch, 1960).

Case Study: St. Lazare Station in Paris is imbedded underground beneath a dense urban fabric that does not allow for much natural light to enter that station. However, it still manages to imply the ① locations of above buildings by ② exposing their structure in the ③ main ticket hall below.



Figure 24 - Section of St. Lazare Station showing relationship to urban fabric above.

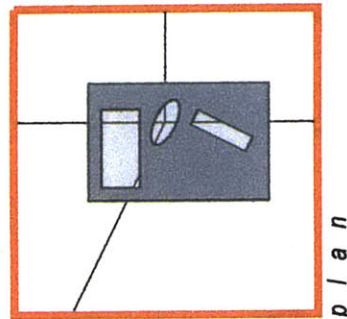

DP-2 Establish major penetrations of unique character that establish visual connections to different kinds of major domains within and outside of the station. At the same time, it should be evident that they are part of the same architectural system.

37

Case Study: *Satolas Station in Lyon has a cathedral-like structural system with many different kinds of penetrations. ① Aisle-like tubes of space cut through the entire station in the longitudinal direction, implying the direction of rail line flow and therefore the orientation of the waiting platforms. ② Groups of residual penetrations between the buttress-like structure occur more frequently in the lateral direction, revealing the sky through the roof, the exterior landscaping through the perimeter, and circulation through the interior.*

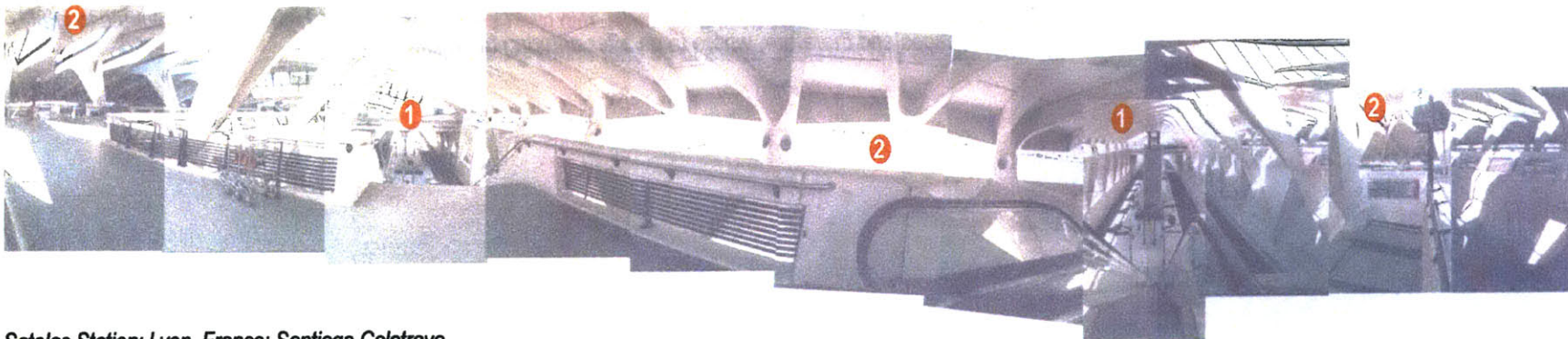

Satolas Station; Lyon, France; Santiago Calatrava

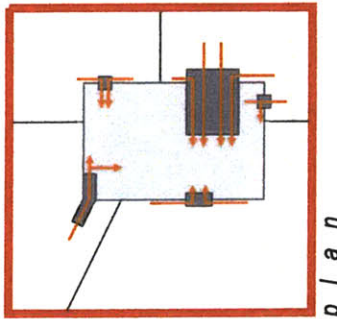

DP-3 Establish hierarchy of station entrances that is legible from a distance. Ideally, the main ticket hall should be exposed from the city. Where this is not possible, the main ticket hall and entrance should at least be marked in a way that it is clearly legible from an urban distance. Secondary entrances should be delineated with similar architectural qualities, but at a smaller scale. "Landmarks become more easily identifiable, more likely to be chosen as significant, if they have a clear form; if they contrast with their background; and if there is some prominence of spatial location (Lynch, 1960).

Case Study: At Atocha Station, Moneo cleverly designed a ① below-grade plaza that allows clear views from all around it of the ② thin walkway leading to the ③ station entrance, emphasized by a ④ clock tower. While the actual entrance doors are not visible, the architecture implies where the main entrance is from an urban distance. The ⑤ secondary entrance is clearly visible as the intersection of the plaza and the main building. The station also uses a ⑥ large, thin roof canopy floating on a high forest of columns to imply the train spaces and therefore, where to go after entering the station.

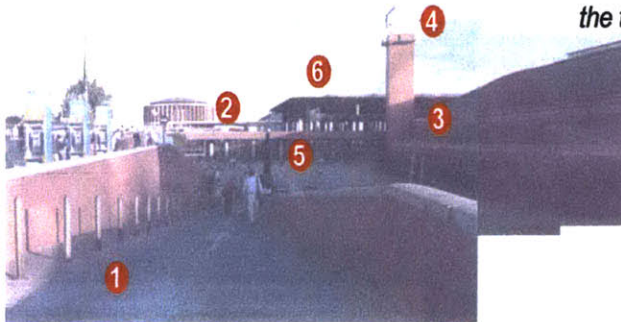

Atocha Station; Madrid, Spain; Rafael Moneo;

DESIGN PROPOSITIONS

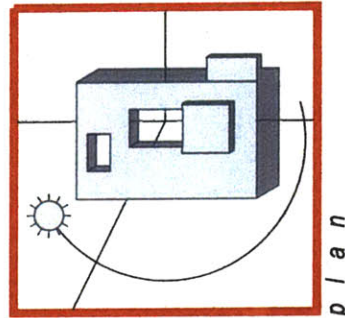

DP-4 Use architecture to help indicate building orientation by registering natural light within station. The design should also prevent sun glare into the interior spaces by using reflected light rather than direct light.

39

Case Study: AREP's TGV station at Avignon clearly indicates its orientation from all parts of the ① main ticket hall. The building is essentially two massive, curved walls that lean onto each other. The ② southern wall reveals its orientation by the sharp shadows cast by ③ deep window mullions. In contrast the ④ northern wall is a glass façade, maximizing views of the clear, blue sky.



TGV Station; Avignon, France; Agence des Gares/AREP

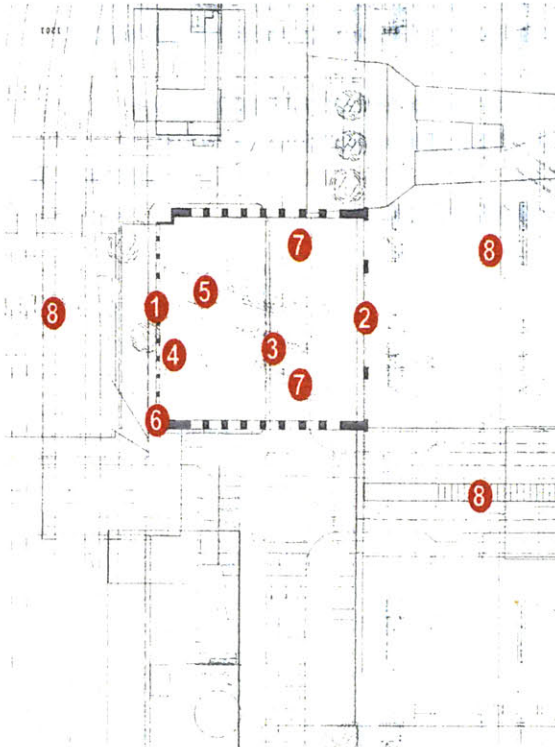
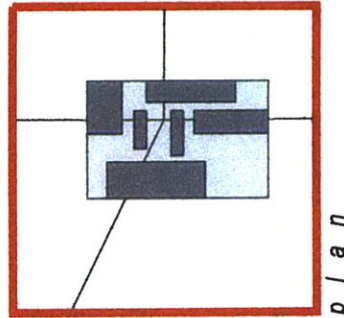

DP-5 While the overall station should be simple and efficient, selective elements should be composed asymmetrically to emphasize the unique qualities of different programmatic spaces. Studies in completely symmetric stations, there is a greater tendency for initial users to make inaccurate navigational choices (particularly when in a hurry), leading to missed connections that might otherwise have been made (see Beck, 1983)

Case Study: The asymmetric elements of Euralille station are precise, occurring primarily at the critical decision points of the station. These include ①, ② different scales of punched openings in the concrete box at the two ground level entrances and ③, ④ different kinds of circulation arrangements stemming from the ⑤ intermediate level within the station, halfway between the train platforms and ground level. These moves are very successful in establishing unique spaces where navigational decision-making is most critical. It is important to note however, that the true wayfinding success of these asymmetric elements lies in their relationship to the overall symmetry of the ⑥ concrete box enclosure and of the ⑦ vertical structure. The symmetric elements provide a stability to the scheme that is vital for initial orientation. On an urban scale, this symmetric cube of space is also a critical organizer, establishing a domain of clarity in the midst of a ⑧ chaotic infrastructural constellation.

Figure 25 - plan of Euralille Station; Lille, France; OMA

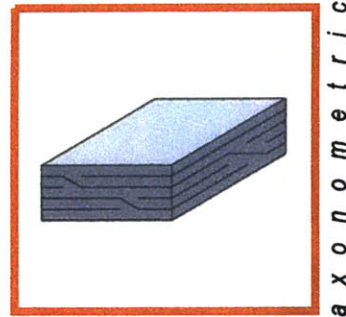

DP-6 Expose the building section at the perimeter to reveal the interior organization from an urban distance. Where stations are sufficiently complex, this should occur on the interior as well.

41

Case Study: At Satolas, Santiago Calatrava designed an intricate cellular system of ① structural bays that are repeated in a sausage-like form as far as is necessary for the length of the ② train waiting platforms. Taking advantage of the fact that stations can be open air, this form is cut at either end, exposing the ③ interior spaces that lie beyond. This move also serves to convey the fact that the entire building is essentially bare structure, a fact that is not as apparent from the longitudinal sides.

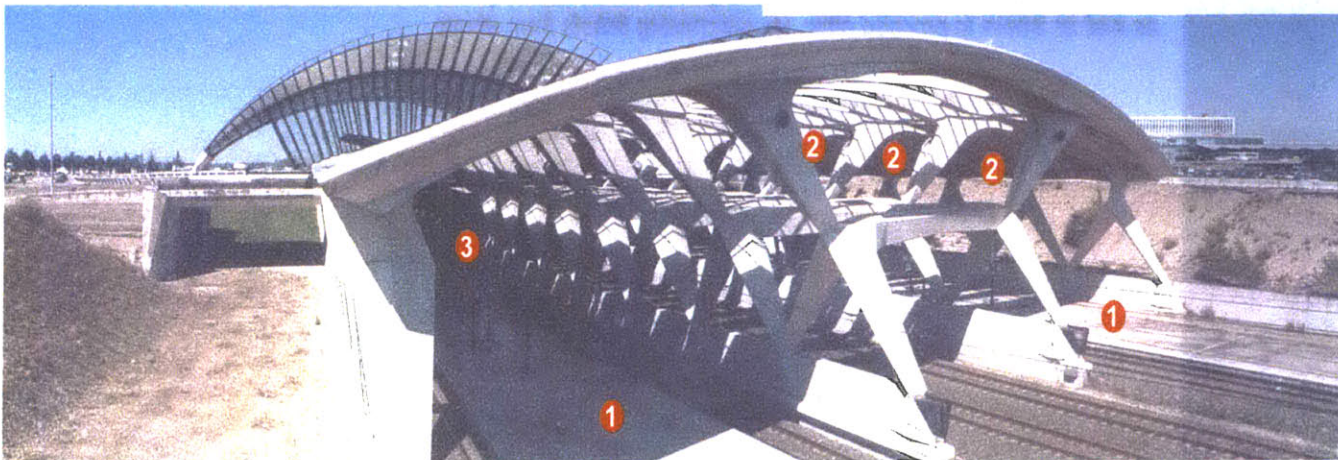

Satolas Station; Lyon, France; Santiago Calatrava

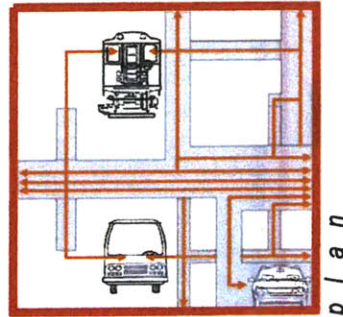

2.4 Architectural Scale: Spatial Perception

DP-7 Visually expose circulation and its hierarchy as much as possible.

Case Study: It is clear how to move through Foster's Bilbao metro stations. The overall space is a simple, ① concrete tube which facilitates an immediate mental image of the ② train platforms domain. The ③ circulation elements contrast, being composed of finely articulated metal stairs and platforms. They are completely exposed, allowing an unusually clear understanding of how to exit or span the tracks from below as well as where to proceed after ④ purchasing tickets from above.

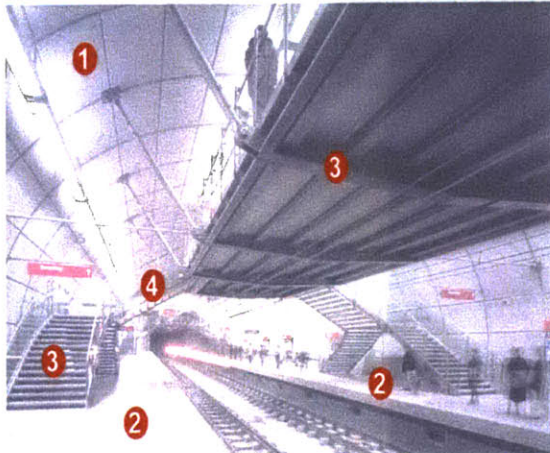
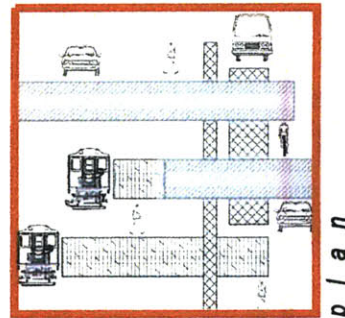

Figure 26 - Abando Station; Bilbao, Spain; Foster and Partners



DP-8 Establish different textures to delineate different modal and transition spaces.

43

Case Study: *Satolas* is primarily constructed from just one material, concrete, exploited through texture in several different ways to facilitate wayfinding. At a human scale, it helps to orient users on the train platforms. A relatively smooth texture is applied to the ① *main walking areas* to aid in walking the long distances of the concourses. A rougher texture is used at the ② *platform edges* to warn users of the close proximity to moving trains. On a larger scale, the roof structure is inter-woven to create a macro-texture that aids orientation by spatially knitting the station into one, clear architectural language. The residual spaces between this roof texture also help to guide users by implying the functions below them. Over the train platforms at either side of the station, the roof structure is filled in with ③ *opaque panels*, providing shelter from rain. However, the structure is more open in the ④ *middle of the roof*, where there are no platforms and the TGV passes through without stopping.

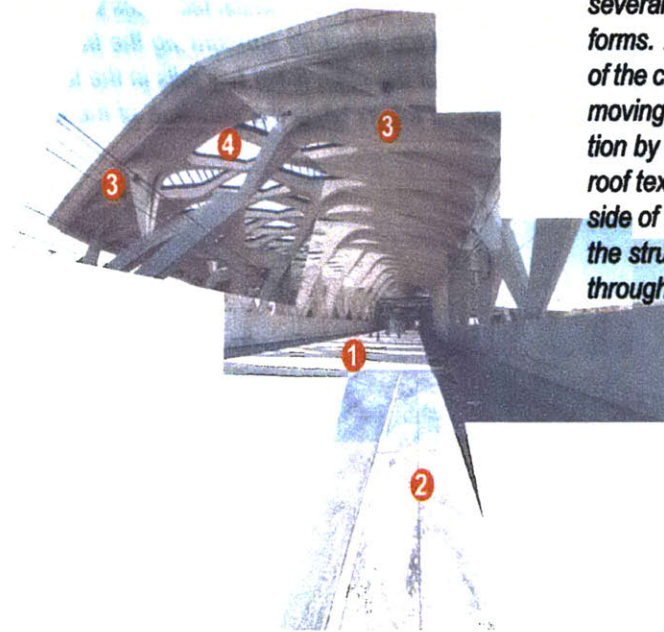

Satolas Station; Lyon, France; Santiago Calatrava

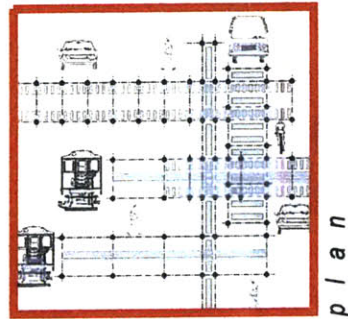

DP-9 Establish different kinds of structural rhythms to delineate different kinds of domains

Case Study: At Satolas Station, a bone-like architectural language exists throughout. However, it clearly takes on different characteristics between the ① trains and the ② main ticket hall, which facilitates wayfinding both from the exterior as well as from the interior. The grain of the structure surrounding the trains is oriented in the longitudinal direction while the grain of the structure of the main ticket hall falls in the lateral direction. In addition, the train structure is more of a 3-dimensional matrix while the structure of the main entrance takes on more of the characteristics of an envelope.



Satolas Station; Lyon, France; Santiago Calatrava

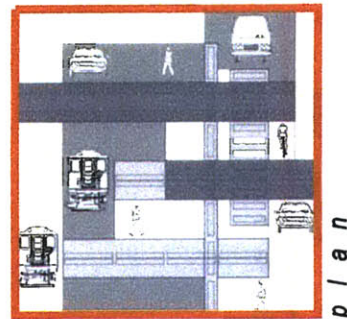

DP-10 Establish different degrees of transparency to delineate different kinds of modal and transition spaces.

45

Case Study: AREP writes that “matter is at the service of light, it refracts or absorbs it, it carries it to the very depths of a building, or catches it in the latter’s rugged surfaces” (Duthilleul, 1998). This notion of “catching” light comes into play at the Station in Charles-De-Gaulle Airport. Within it, several different qualities of light are established, helping to give contrast to the areas of the ① RER trains (which has a ② lower, more transparent roof, allowing more direct natural light penetration) and the area of the ③ TGV trains (with a ④ higher roof, establishing a space with more indirect natural light). This contrast is particularly helpful in clarifying the different domains of this station, where the complexity of structural systems might otherwise confuse. At the same time, the transparencies in the roof enables passengers to “anticipate the routes towards their chosen mode of transport while staying within sight of the sky” (Duthilleul, 1998).

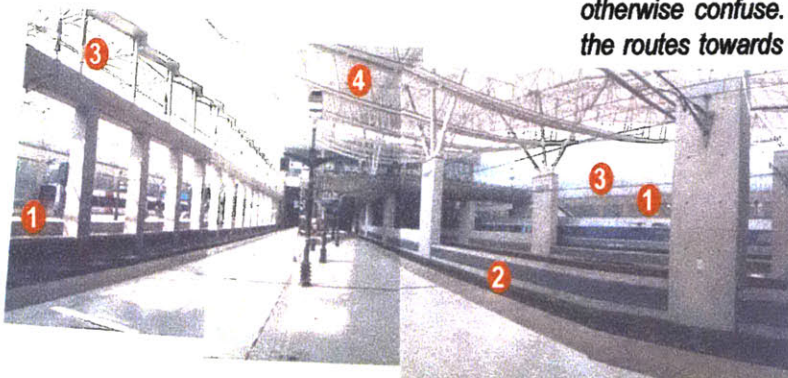

TGV Station, Charles de Gaulle Airport; Paris, France; Agence des Gares/ AREP

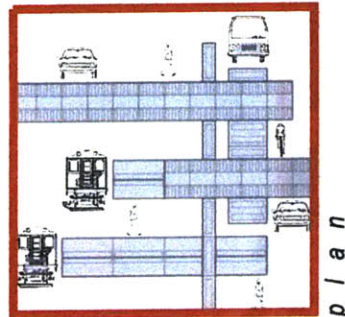

DP-11 Establish different material joint and panel proportions based on the scale of modal units (car, bus, etc.) to delineate different modal and transition spaces

Case Study: The space for the train platforms at Atocha Station is established by a relatively simple flat metal roof raised high above the tracks on a forest of columns. The columns are spaced at a distance relatively equal to the length of a ① train car. This sets up the roof structure and panel dimensions which relate to the program below it. Above the trains, the roof has several ② opaque elements, also of dimensions related to a train car's length. However, above the ③ waiting platforms, the ④ roof elements are closer together and are articulated to allow more light penetration. This relates both in scale and in function to the human users below.

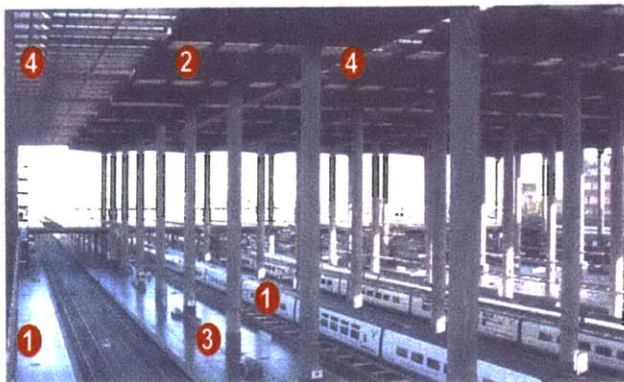

Atocha Station; Madrid, Spain; Rafael Moneo

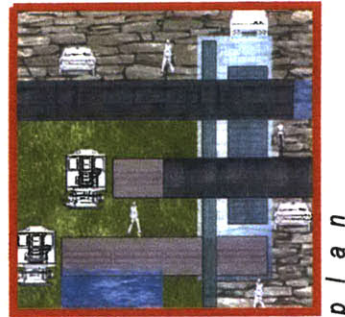

DP-12 Establish a logical system of material use in order to help delineate different kinds of modal and transition spaces. The materials should also be a sensitive response to who or what they are supporting.

47

Case Study: In describing AREP's design philosophy, Duthilleul (1998) writes that they see materials as "the carriers of very simple meanings which dictate their choice. In order to be reassuring, the plinths which are anchored to the ground are constructed of light-colored cement or stone, to cover without oppressing, light, finely worked steel is used for the building's heights, transparent glass there where one's gaze needs to pass and lastly, wood, the most domestic, warm and absorbent of all materials, which comes closest to the traveler, on the floor beneath his feet or adorning the walls alongside which he passes." This philosophy can be seen at La Plaine- Stade de France, where the two types of load bearing structure in the building are treated differently based on the program they support. A system of ① white concrete viaducts supports the heavier, machine circulation (trains), contrasting with a ② more articulated steel and wood system that holds up the lighter, human circulation and waiting platforms. Because these materials are all exposed to the ground level entrance where the train platforms are not yet visible, they establish a system that implies their location

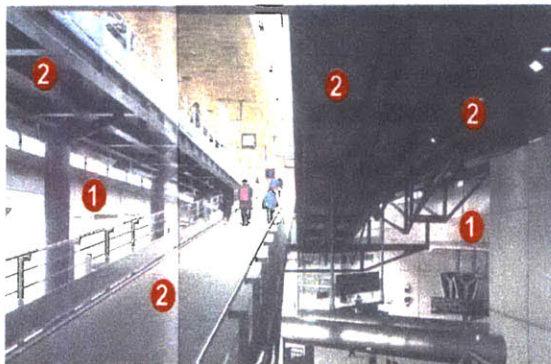
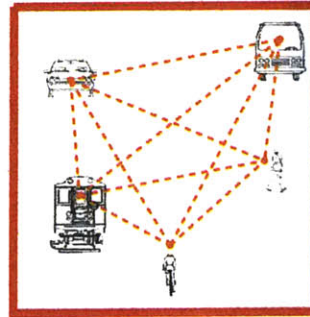
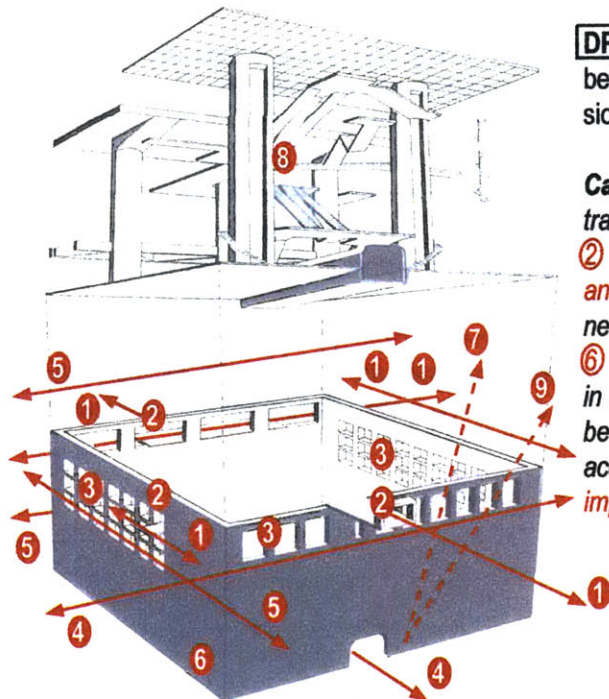

Figure 27 - Stade de France Station; Paris, France;
Agence des Gares/ AREP



2.5 Architectural Scale: Visual Access

DP-13 Establish as many inter-modal views as possible. While this is important for efficient navigation between modes, it is also important for establishing the user's sense of security, which leads to better decision-making.



Case Study: Euralille station was the most ambitiously multi-modal station studied. Aben describes it as “a transferium for ① pedestrians, an interchange for escalators, lifts, spiral stairs, a tube station, a taxi rank, ② entrances, exits and accesses. From this slow-moving, small scale and individual system, ③ windows and balconies give a glimpse of the rapid, large-scale and multitudinous system of ④ rail and ⑤ motorway networks” (Aben, 1999). Euralille maximizes views of these different modes primarily through a simple, yet ⑥ excessively large volume of space. The space could have been more linear and efficient as is the case in most of the other stations studied. However, because the site boundaries at Euralille are so tight, and because it is one of the deepest stations studied, making a linear space would have greatly limited visual access, creating ⑦ sharper view angles at the perimeter and allowing the ⑧ circulation to block the ⑨ most important vertical views.

Figure 28 - Euralille Station; Lille, France; OMA

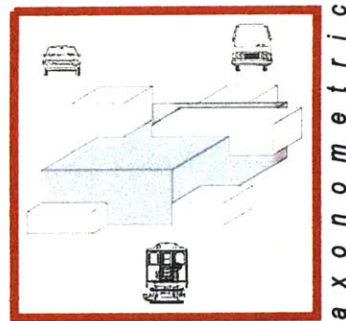

DP-14 Establish one prominent transition volume as a collector space for circulation to and from individual modal volumes. In general, the transition volume should be the most architecturally significant in the project, being prominent both from within the station as well as from the exterior.

49

Case Study: A complex arrangement of ① vehicular and ② pedestrian circulation elements lies between Satolas Station and Satolas Airport. In spite of this, it is still clear where the ③ entrance of the station is because of its size and unique character. As a result, it functions as an organizer on the site, making legible the fact that it is a major node and implying even from a distance the fact that it serves to collect circulation from the ④ airport and ⑤ trains.

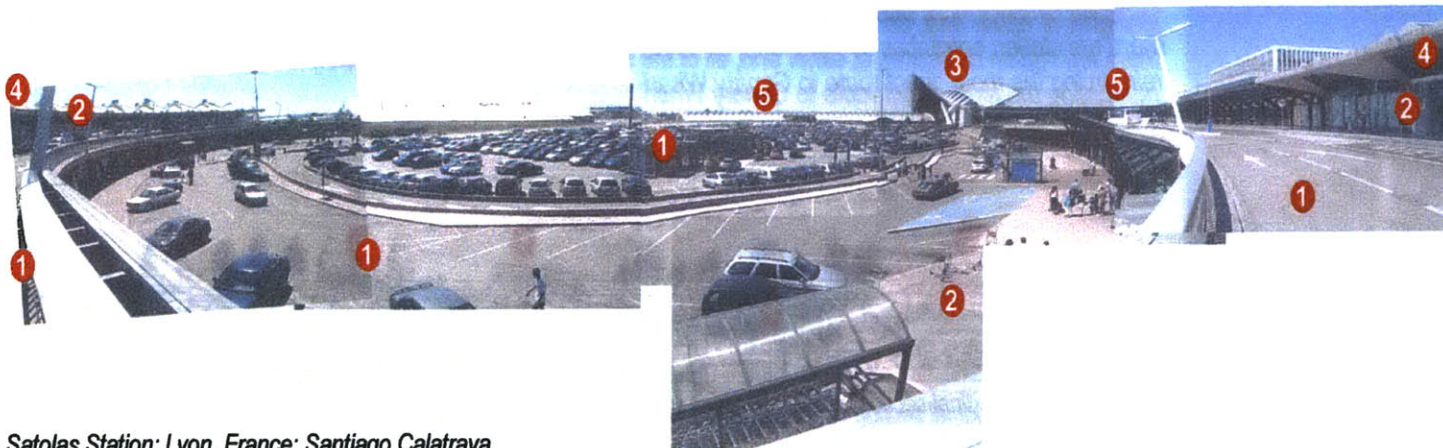

Satolas Station; Lyon, France; Santiago Calatrava

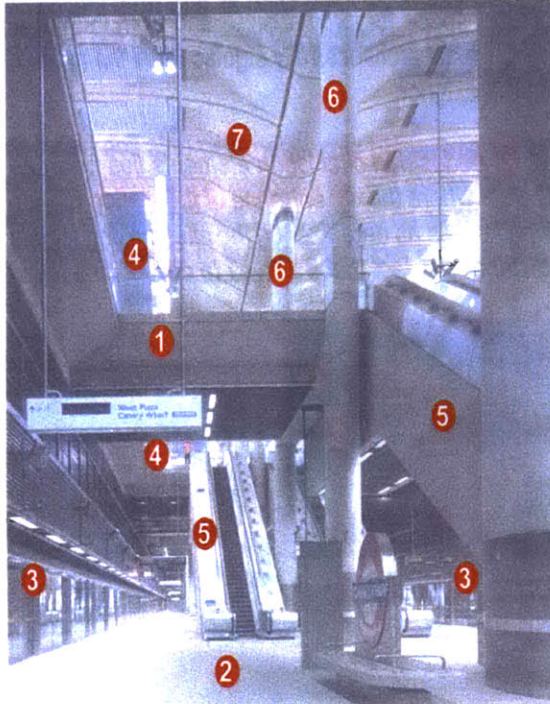
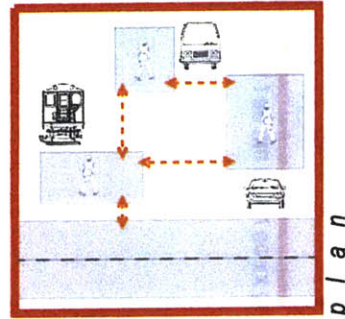

Figure 29 - Canary Wharf Station; London, England;
Foster and Partners

DP-15 Establish connections between different domains that are as direct and visually clear as possible.

Case Study: Canary Wharf Station is essentially a massive, double-level corridor with a ① *transition domain* one level below ground and a ② *train concourse domain* two levels below ground. The station truly demonstrates clarity in its restrained simplicity. Transitioning between trains is clearly legible because both ③ *trains* share the same ② *subterranean, plaza-like spaces*. While the entire station is not visible from the train platforms, the large ④ *penetrations* between ⑤ *circulation elements* allow visual cues of a ⑥ *different kind of structural system above*. There, the curvilinear structural forms convey feelings of lightness, implying a final level or ⑦ *roof surface*. Upon ascending to the transition level, this is reinforced by massive, ⑧ *organic skylights at either end*, penetrated by the final circulation to the street. It is also important to note that while there are station entrances at either end, all of the major escalators are ⑨ *sloped towards the major entrance*, reinforcing the most direct route to Canary Wharf



Figure 30 - Longitudinal section of Canary Wharf showing relationship of circulation to ground level

DESIGN PROPOSITIONS

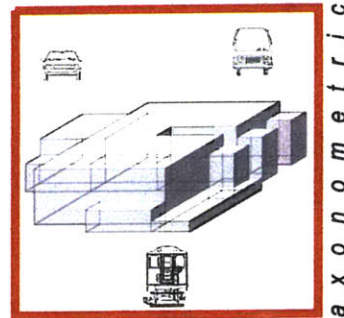

DP-16 Establish different volumetric rhythms to denote different programmatic spaces.

51

Case Study: The underground spaces of Stadelhofenc Station are made up of volumes of different character. The majority of the structure is repeated at regular intervals, establishing a ① tube of space for browsing between ② commercial shops. However, the volumes between this structure ③ expand to different proportions to signify where ④ vertical circulation penetrates.

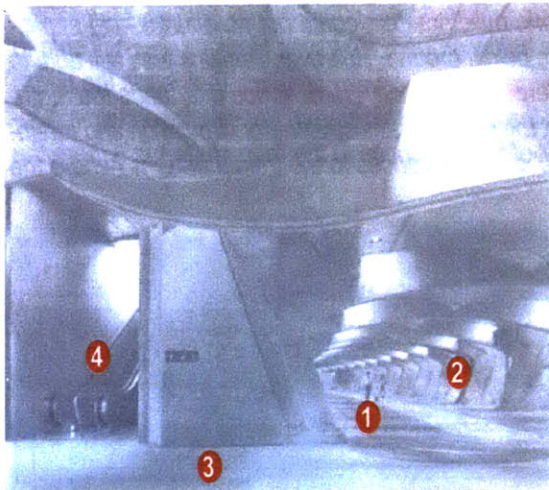

Figure 31 - Stadelhofen Station; Zurich, Switzerland;
Santiago Calatrava

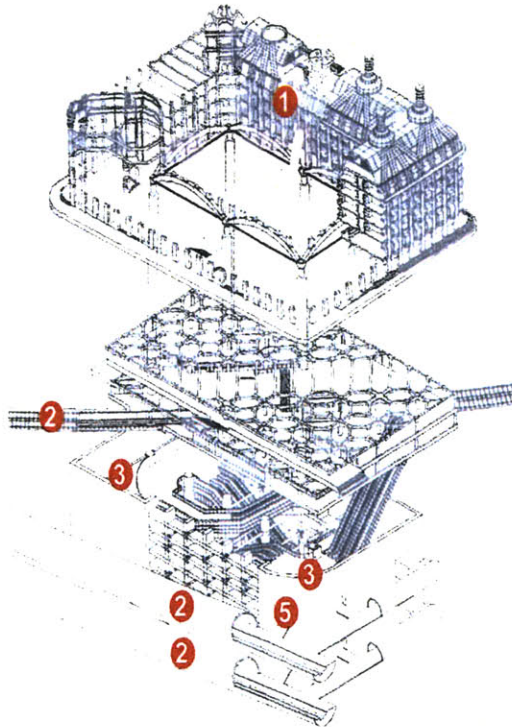
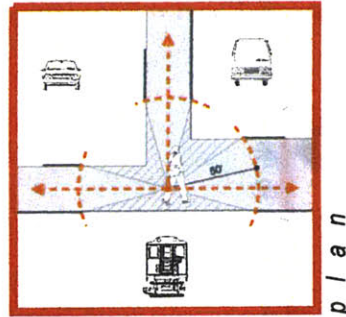

Figure 32 - Axon of Westminster Station; London, England; Michael Hopkins and Partners



DP-17 Maximize inter-modal views within 50' of major decision points. This will allow users at least 15 seconds to process their environment before having to make a decision, a time period that should be enough to make an informed navigational decision. "Selecting an appropriate action requires prediction, that is, an assessment of what might happen next" (Kaplan, 1976).

Case Study: Of the stations visited, Westminster's site had probably the tightest initial site constraints, being situated completely below ground, under ① several historic buildings that could not be altered, and servicing ② non-parallel train lines on at least three major levels below ground. However, Hopkins was still able to establish a legible circulation system, organized by a ③ large elliptical cavern of space that feeds the metro lines. A necessary ④ density of structure exists throughout the center of this cavern (for circulation and retaining wall support) but ⑤ spaces open up within at least 50' of the entrances to the train platforms (where the most important navigational decisions need to be made).



Inside the circulation collector volume of Westminster Station

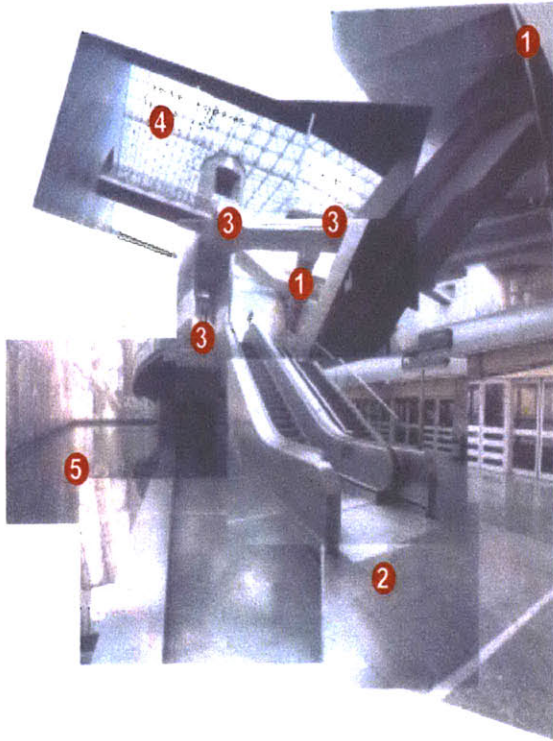
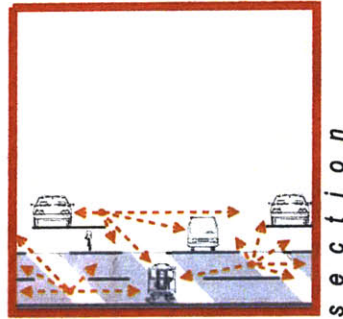

DP-18 Establish regular vertical views between horizontal strata of the station. While it may not be possible to view the entire station from every vantage point, each significant domain should be visible from at least two other significant domains. “People like to look down on their world. The feeling of being able to view everything from above makes it easier to make objective decisions concerning direction. These vantage points become critical at decision points where the passengers can view level changes, transit systems or the direction to be taken to continue on to the next destination” (Alexander, 1969).

Case Study: Between the ① *ground level* (which extends into the station through bridges) and ② *train concourse level* of Euralille Station, there are at least ③ *three other intermediate levels* within the circulation. Because they are essentially just circulation, and because the overall space is very generous, there is plenty of space between the intermediate levels to allow for multiple views throughout the station. This allows ④ *natural light* to penetrate all the way to the train level, a feat that very few deep, subterranean train stations do well. The ⑤ *reflecting pool* at the bottom also aids wayfinding both by reflecting this light into the lower areas of the station and by providing views of some spaces that would not be visually available from direct line of sight.

Euralille Station; Lille, France; OMA

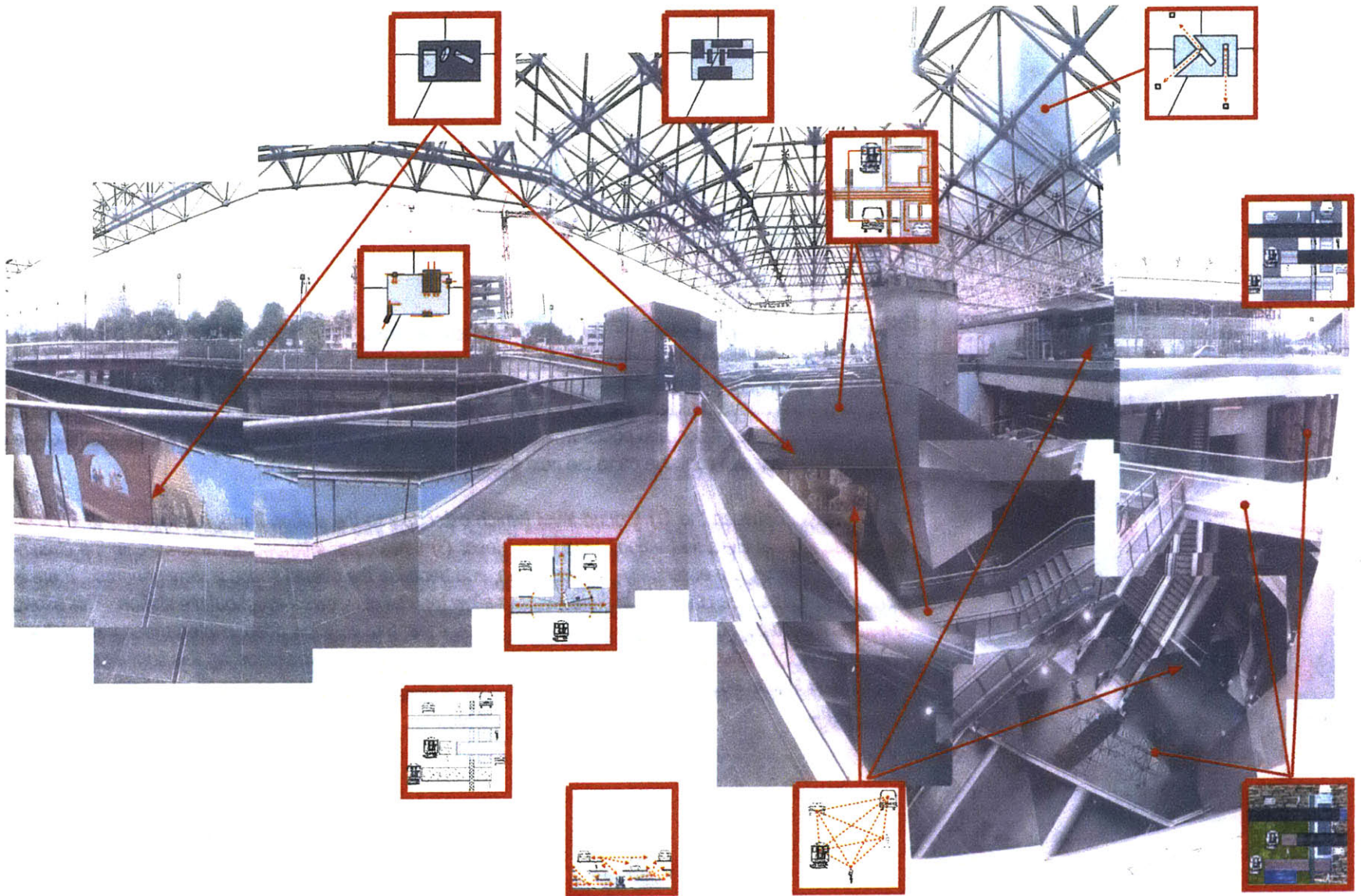

Euralille Station analyzed through design propositions

2.6 Primary Propositions

55

While it may be obvious, it is useful to note that many of the case-study stations could be associated with multiple design propositions. Those stations that were the most successful at orienting users tended to apply to more of the propositions while being primarily driven by just a few. In these more successful stations, the architects generally carried out these primary propositions in an architecturally rich but economically excessive way. It is a final proposition of this thesis that this excess is necessary for wayfinding in multi-modal transportation hubs and that it is justified by the benefits (see section 1.1)

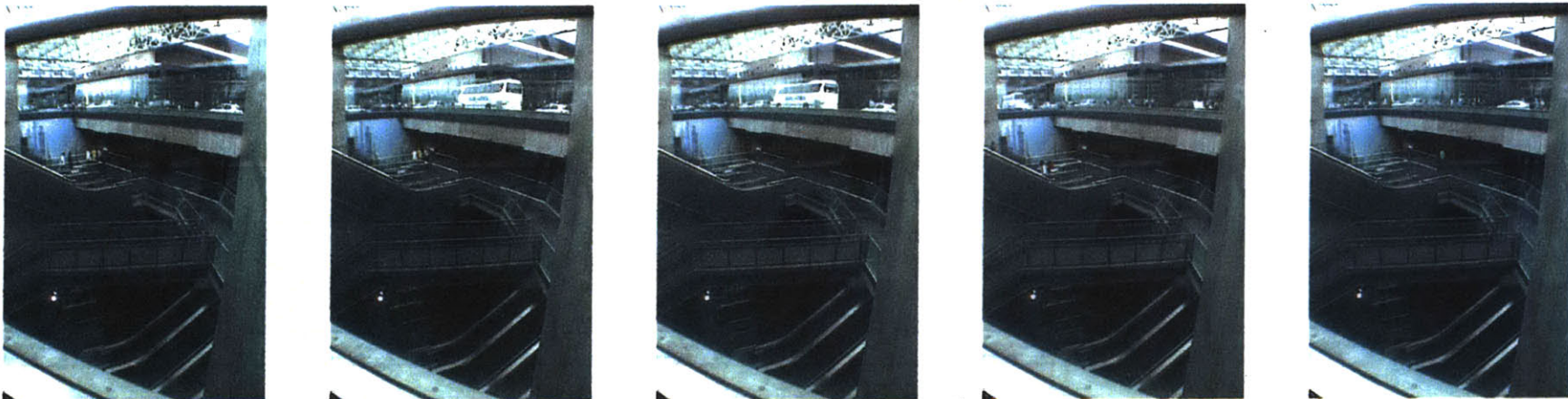

Video images of Euralille Station taken every minute, indicating change in transportation flow over time

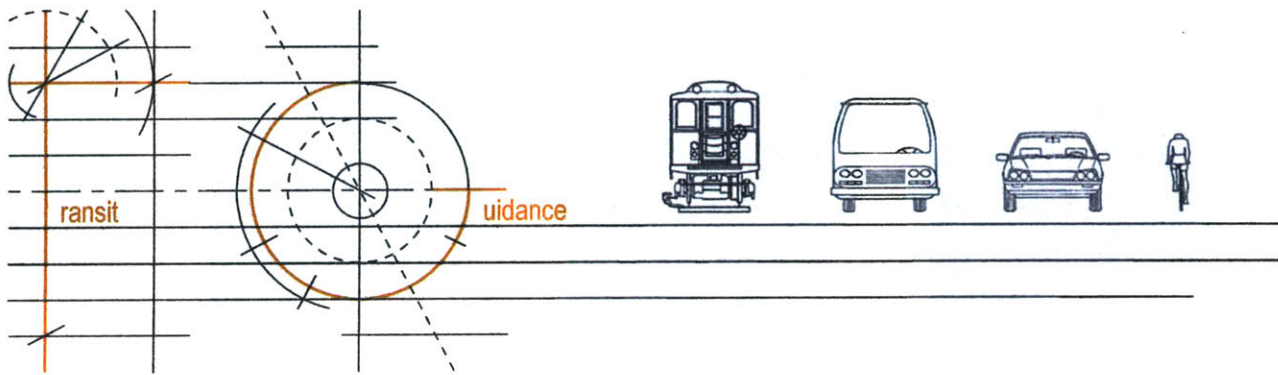



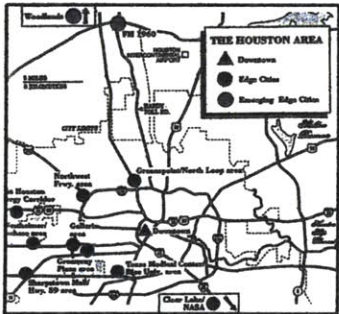
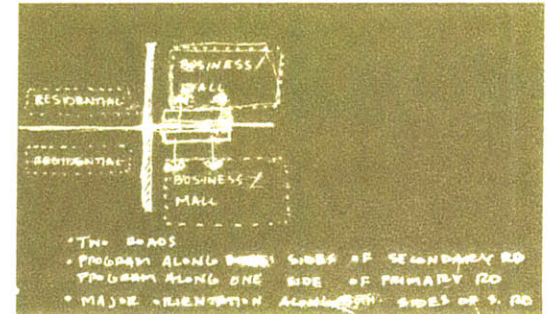
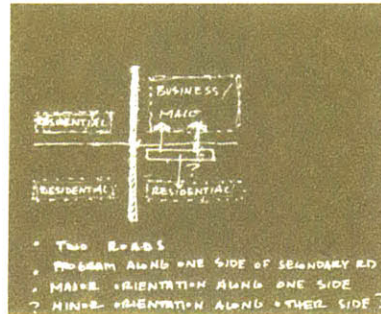
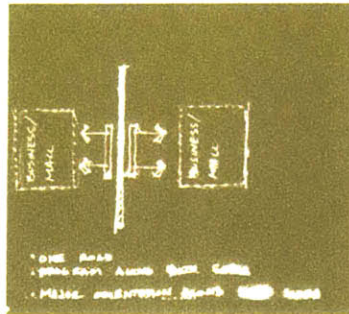
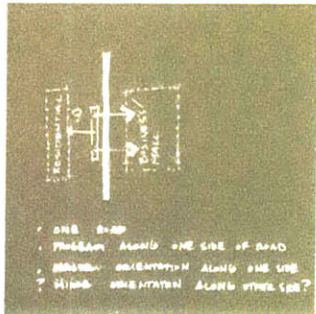

Figure 33 - Houston



Figure 34 - Phoenix

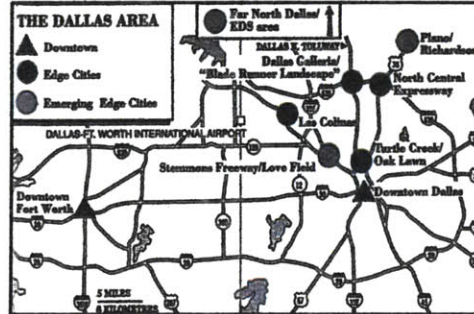

Figure 35 - Dallas

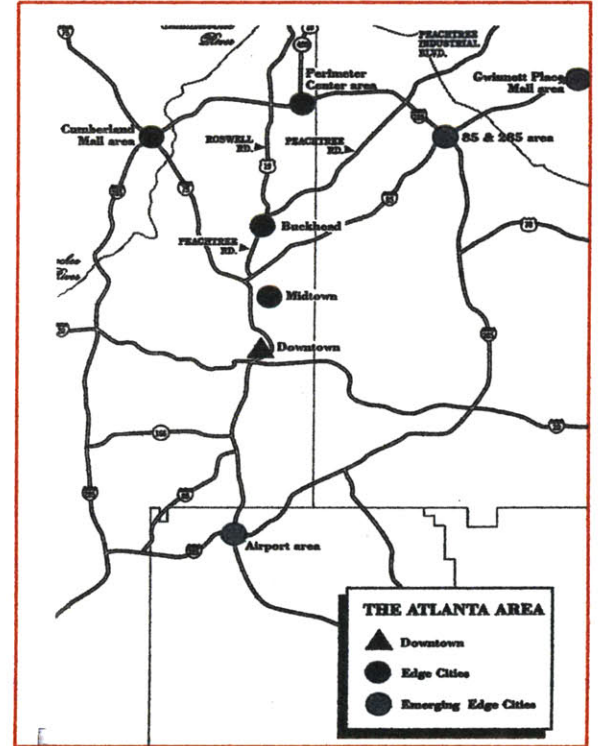

Figure 40 - Atlanta



Figure 36 - Detroit



Figure 37 - San Francisco

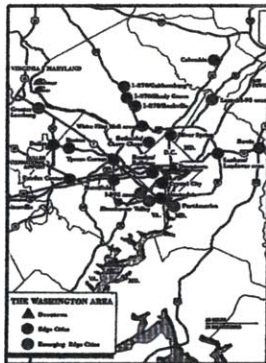
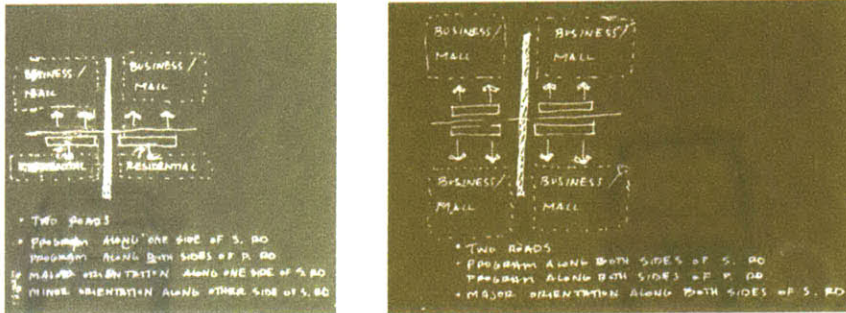

Figure 38 - Washington



Figure 39 - Boston



diagrams of generic edge-city conditions for transit stations

3.1 Primary Site Conditions

As stated earlier, the sites of focus for this thesis are edge-cities. There are many different conditions within edge cities, but they almost always have at least one major road and mixed program, including residential, office, and commercial retail. Some of these possibilities were diagrammed above, based on different arrangements around a single road or an intersection.

3.2 Relevant Cities for Exploration

Joel Garreau identifies several areas of the United States where the highest density of edge-city conditions exist. Some of them are provided at the left. Of those areas, Atlanta is the chosen city of focus.

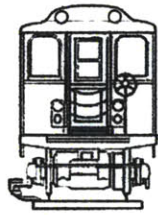

60

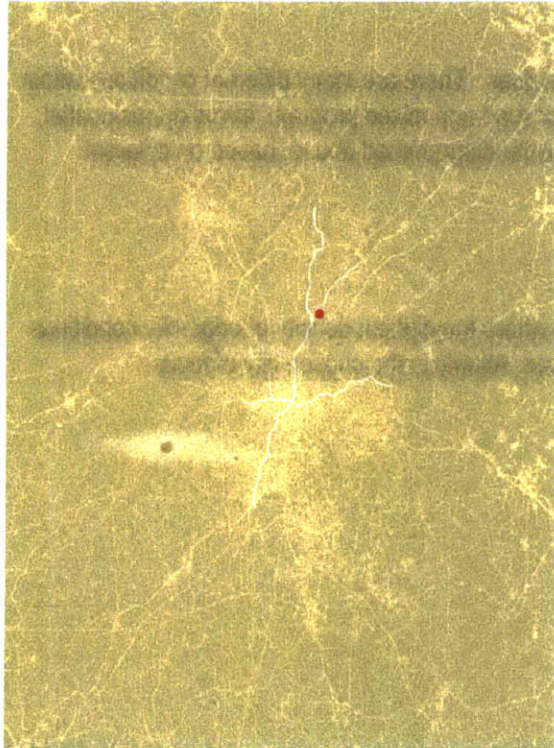

Atlanta by train

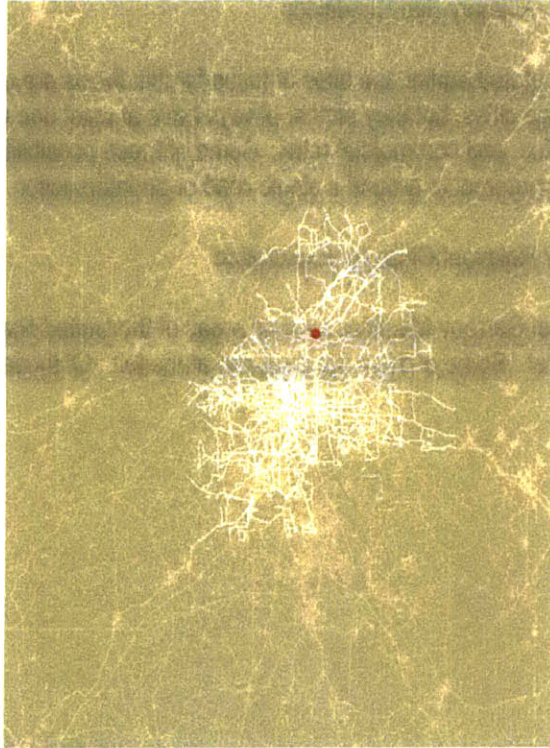

Atlanta by bus

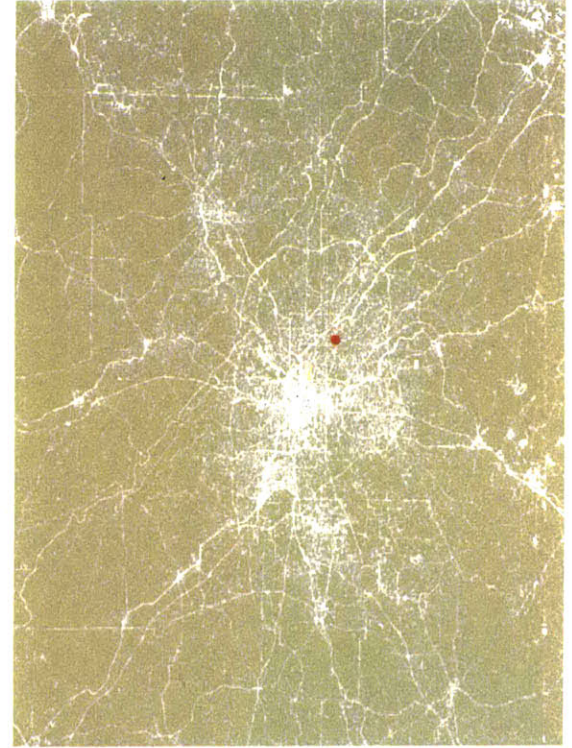

Atlanta by car

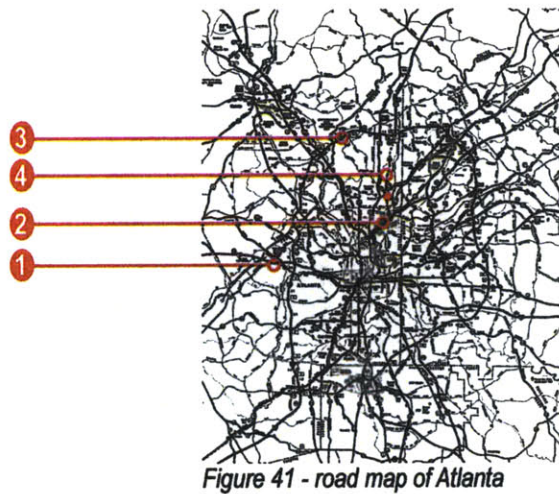

Figure 41 - road map of Atlanta

3.3 Atlanta

Atlanta is the chosen site for this project because it is a truly multi-modal city. It is the most populated city in the Southeastern United States, and yet has the overall density of a much smaller city. By some estimates, it spans over 1000 square miles. It is impossible to determine where it begins and ends because there are few places that landscape is not prevalent. Rem Koolhaas (1995) writes of how Atlanta is very different from the traditional city. "It's not dense; it is a sparse, thin carpet of habitation, a kind of suprematist composition of little fields. Its strongest contextual givens are vegetal and infrastructural: forest and roads. Atlanta is not city, it is a landscape." Because Atlanta is so spread out, inhabitants have become truly reliant upon the transportation infrastructure. With the possible exception of the small, urban Virginia Highlands neighborhood, there are essentially no places in the city that people can live and work without the use of some kind of transportation.

The majority of people own at least one car and use it frequently. The prevalence of the car overwhelms that of other vehicles. This is evident in the overwhelming contrast in density between a road map and a bus map of Atlanta. The major interstate highways that pass through Atlanta are the ① north/south oriented I-75 and I-85 (which merge through most of the city) and the ② east/west oriented I-20. ③ Highway 285 is the major perimeter highway and the ④ Georgia 400 runs within.

Those who do not have the luxury of a car rely primarily on MARTA, a semi-governmental/ semi-private organization that owns and operates the public bus, inner-city rail, and commuter rail systems. Due to the heavy road congestion that Atlanta is notorious for, most of inhabitants who own cars, still use MARTA to some extent.

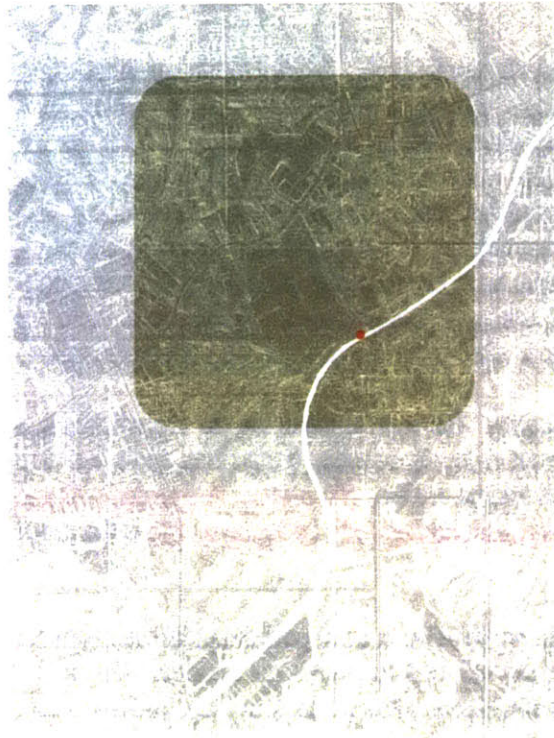
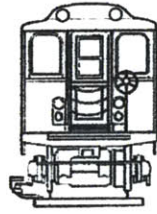

Lenox by train



Lenox by bus



Lenox by car

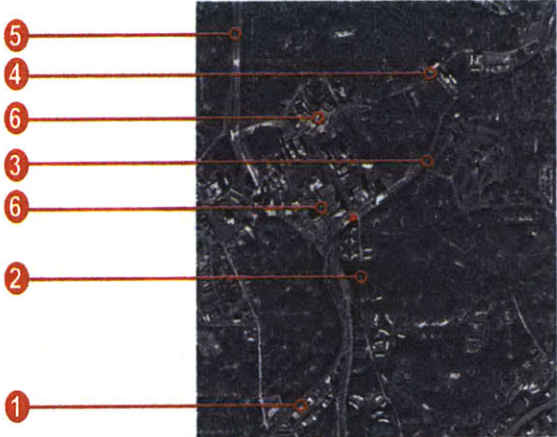

Figure 42 - aerial map of Lenox

3.4 Lenox

The three major transportation modes of train, bus, and car all occupy the site at Lenox Station. The ① *MARTA northern metro line and the Southern Freight line* run alongside each other through the site away from the city towards the northeast. The MARTA bus routes are slightly more extensive on the site, occupying the major community roads of ② *Lenox*, ③ *East Paces Ferry*, and ④ *Peachtree Industrial Boulevard*. There are four routes in all and Lenox Station is the terminus for each. They arrive from and depart to the north, east, and south. Cars are clearly the primary mode of transportation on site. The most prevalent circulation of car traffic is on the ⑤ *Georgia 400 Highway* which winds through the site away from the city towards the north. The other major roads either align with this highway, the rail lines, or are oriented around the ⑥ *major malls on site*. Towards the fringes of the site, the program is almost totally residential and accessible mainly by car. Here the roads are the smallest in scale.



Figure 43 - Mall landscape

64



Figure 44 - Residential development

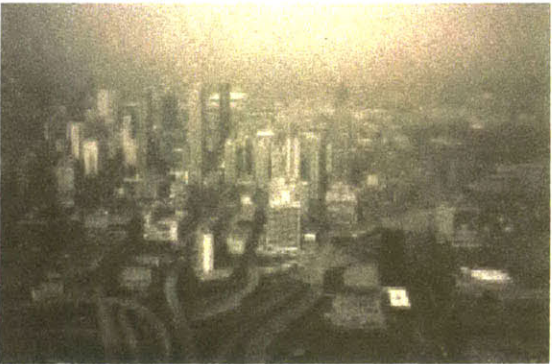

Figure 45 - Business district



Lenox by primary program



Figure 46 - ① Phipps Plaza



② Lenox Residential community



Figure 47 - ③ Train exiting east from Lenox Station

3.5 Site Analysis

Generic Program

Ranal Roark (1995) identifies the three primary programs that compose most of Atlanta as “downtown, residential developments, and malls.” Also included in the notion of “downtown” are the many decentralized business districts that are so common in the city. These are the primary and generic programs that lead to most edge-cities. Lenox is such an area.

- Mall
- Parking
- Landscape
- Business
- Residential
- Road
- Rail

66

Phipps Plaza

Hwy 400

Existing Station Parking

Lenox Mall

Viracon Headquarters

Existing Lenox Station

High Rise Condominiums

Lenox Road

MARTA Northeast line

Georgia Southern Line

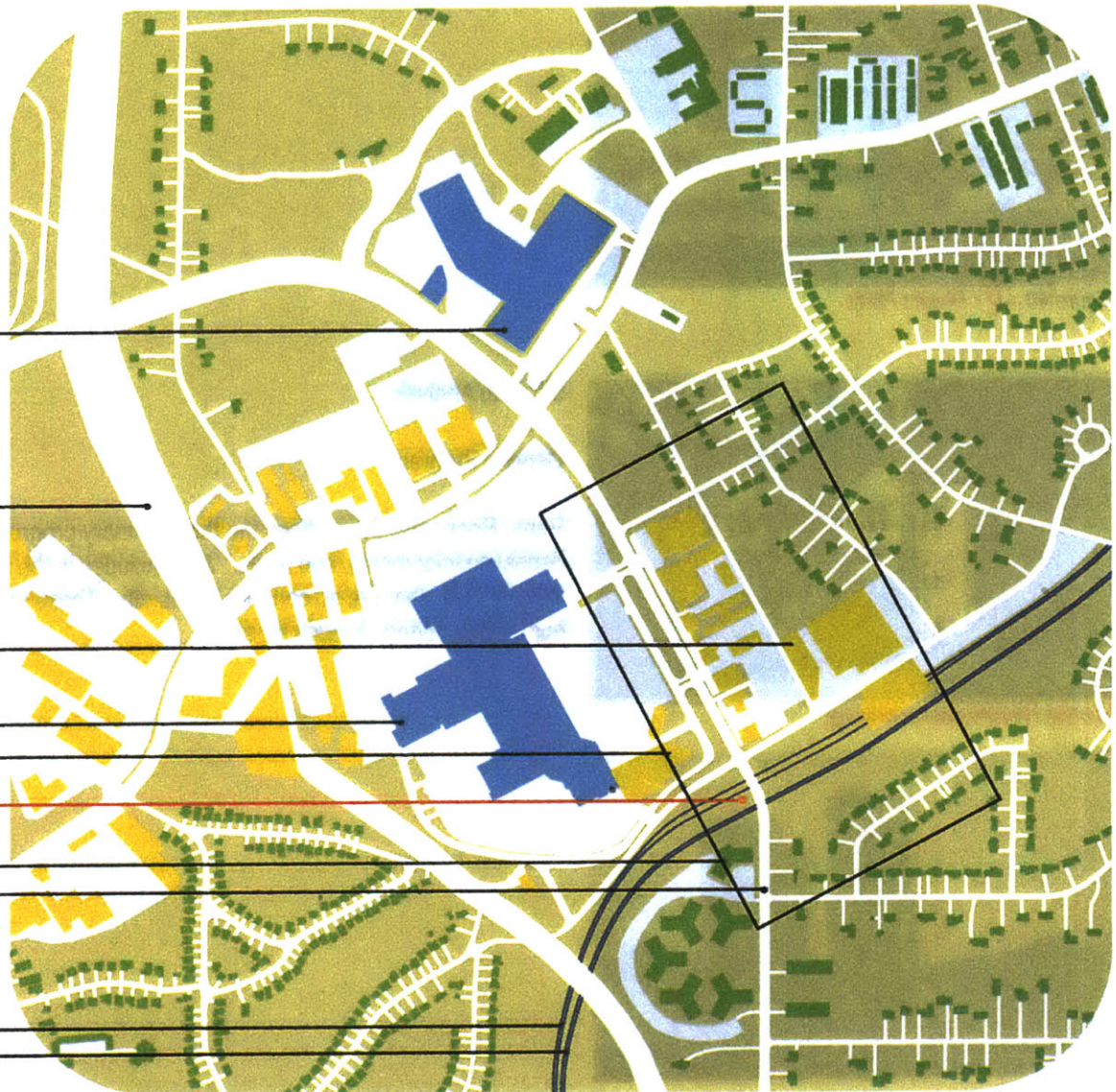

Site Plan of the Lenox Community showing specific program

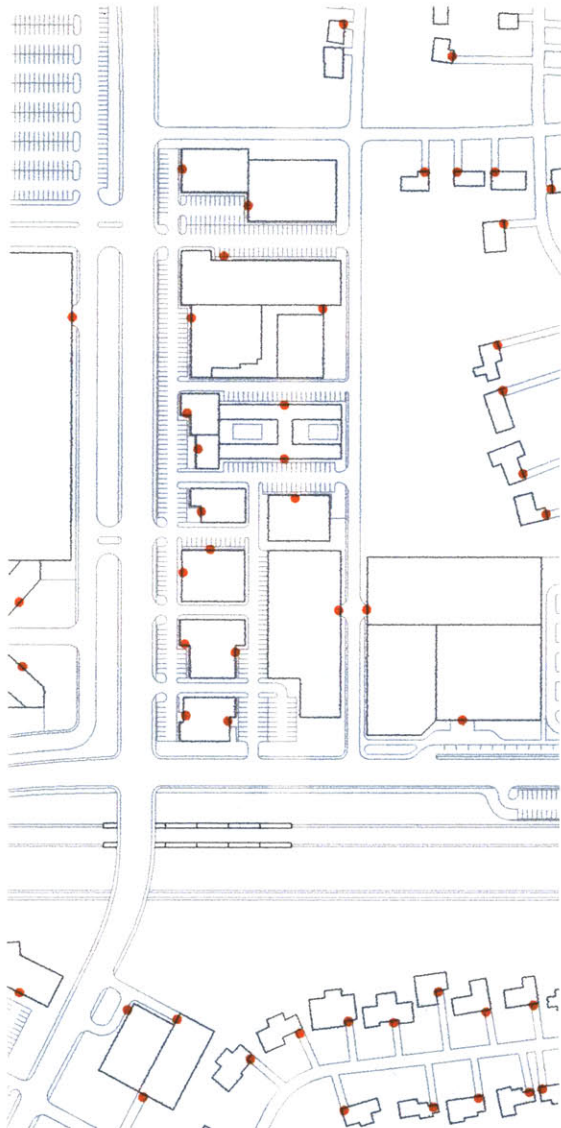

Specific Program

Lenox is a community located northeast of downtown Atlanta, halfway between there and Highway 285. The Georgia 400 passes through and over the Lenox, relating very little to the community itself. The major nodes of activity in the area occur in and around Phipps Plaza to the North and Lenox Mall to the south. Lenox road forms the spine of the Lenox Community, connecting the two malls as well as many businesses and parking facilities of various scales.

Site Plan of the Lenox Community showing building entrances

1 from parking

.....to trains



2 from trains

.....to buses

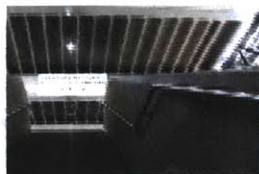

68

3 from buses

.....to parking



4 from parking

.....to trains

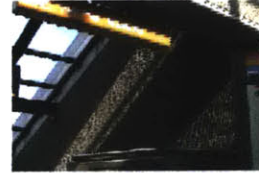

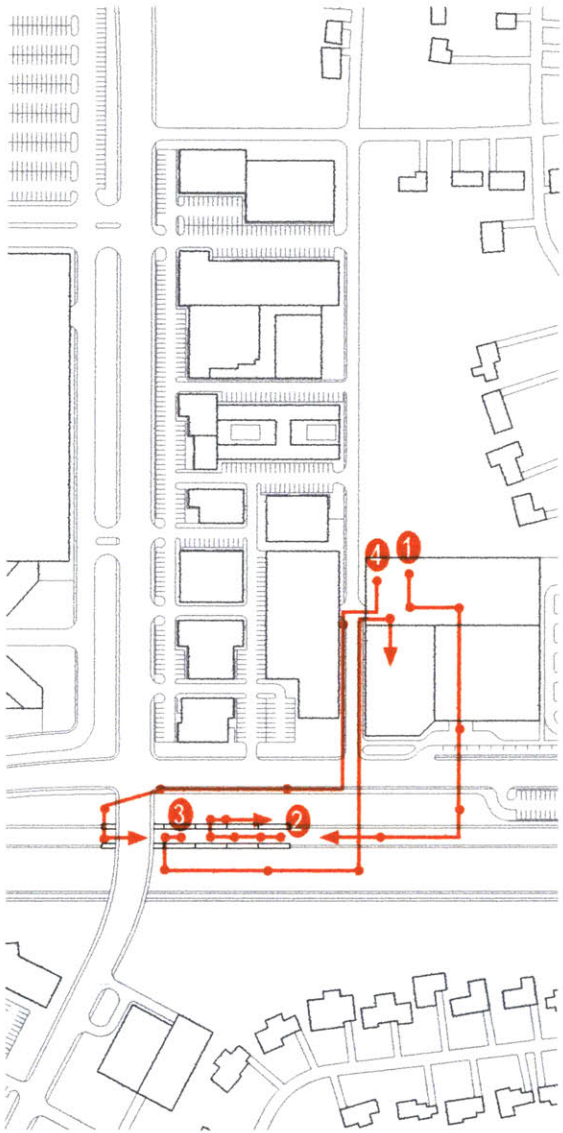

Modal Transitions

Some of the major modal transitions at Lenox Station were studied through video to understand the existing legibility. Based on the design propositions for station wayfinding, legibility was only moderately successful. From an urban distance, the parking for the station was practically impossible to find, due to poor signage and its being located two blocks away (requiring at least two road turns from the station) in a non-descript building. The entrance to Lenox Station was noticeably marked by a two story sculpturally designed building, but it was architecturally unclear what modes were served. The buses were blocked by a concrete wall along the East Paces Ferry Road and the train platforms were eclipsed by the bus infrastructure and the Lenox Road overpass. This arrangement also resulted in wayfinding difficulties within the station. The train platforms were very dark due to all of the overhead infrastructure, creating uncomfortable waiting spaces. Also, important visual connections were not clear from or between any of the major modes (trains, buses, cars).

Site Plan of the Lenox Community showing video survey routes

CHAPTER FOUR: DESIGN EXPLORATION

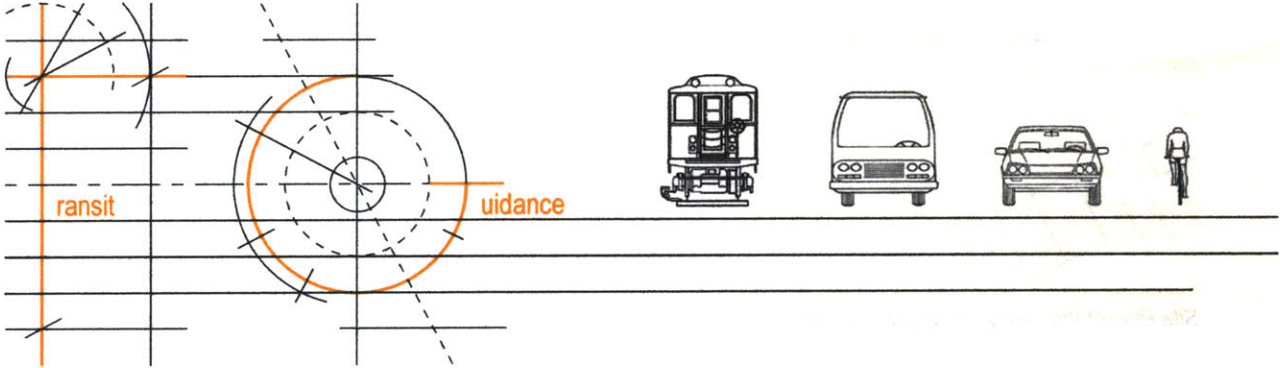

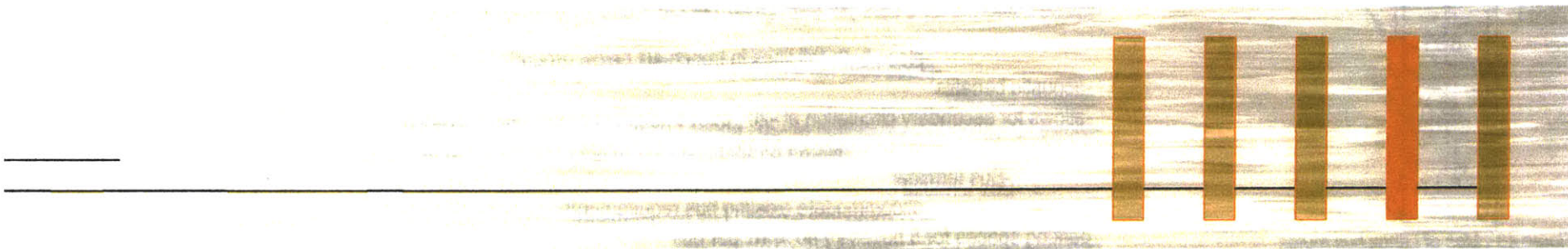

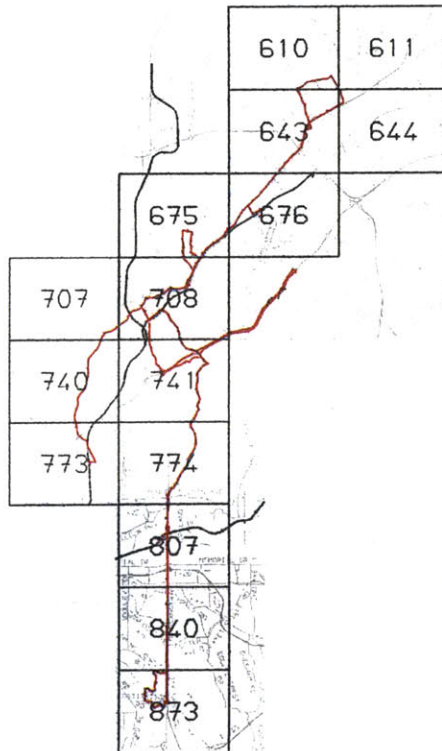

Figure 48 - Map of Lenox bus routes

4.1 Programmatic Assumptions

The following program for the transit station is based on conditions that either presently exist in other MARTA stations, or could easily exist in an Atlanta, edge-city multi-modal station:

- Parking
 - accommodate existing parking requirements
 - parking spaces for 1000 cars @ 20' x 10' per car
- MARTA rail
 - accommodate existing MARTA requirements:
 - waiting platforms for 5 cars per train @ 65' per car = 325' of waiting platform either side of tracks
- Commuter rail
 - accommodate existing Commuter rail requirements:
 - waiting platforms for 8 cars per train @ 80' per car = 640' of waiting platform either side of tracks
- place both rail lines in trench 40' below ground
- acoustic benefits
 - allows for secondary circulation at -20', above height of trains, below overpass.
 - allows for dominant car mode to remain at ground level
- Bus terminal
 - accommodate existing bus requirements
 - parking spaces for 8 buses @ 60' x 10' per bus

- (Each of the 4 bus lines has two spaces, one for bus loading and one back-up space for bus waiting)
- Tickets
 - tickets to accommodate all modes
 - Commercial shops at significant circulation spaces



Figure 49 - Marta metro map

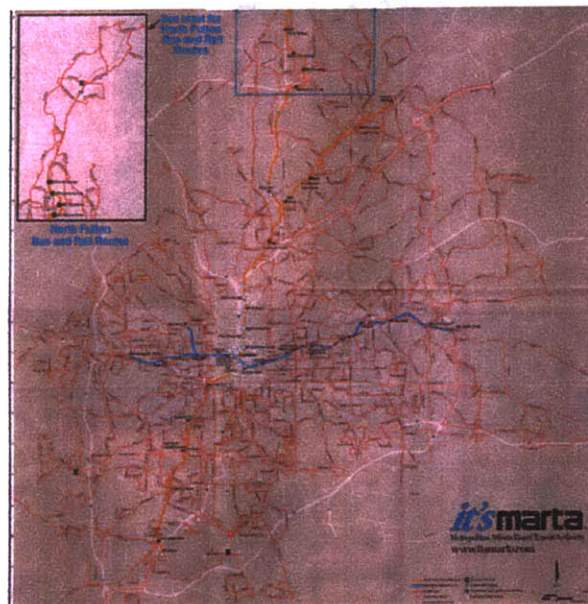

Figure 50 - Marta bus map



Figure 51 - Complementary road map found at many MARTA stations

42. Design Process

The intent of the design process was to be guided by the European/ other relevant precedents as well and the design propositions to the scheme. In order to test the strength of the propositions, it was important to involve them as much as possible.



Figure 52 - Temple Street Parking Garage; Paul Rudolph

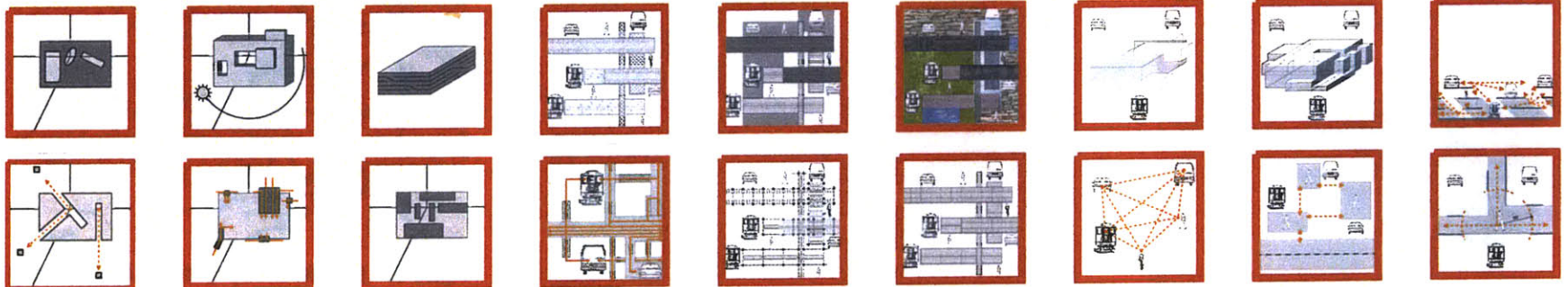

Design Propositions

4.3 Design Decisions

Broad Moves

-one unit, confines itself to the train track trench, the commuter rail, road intersection, access from all sides, bus located far enough away from intersection to prevent back-up.

Modal transition access

After examining the potential for three ticket spaces (one for each of the three collective modes: MARTA rail, commuter rail, and bus) the decision was made that the most efficient design incorporated was one centralized ticket hall that spanned the trench and was located roughly at the intersection of all modes (collective and individual). As a result, one centralized ticket space acts as a collector volume for with one ticket counter that services the entire station.

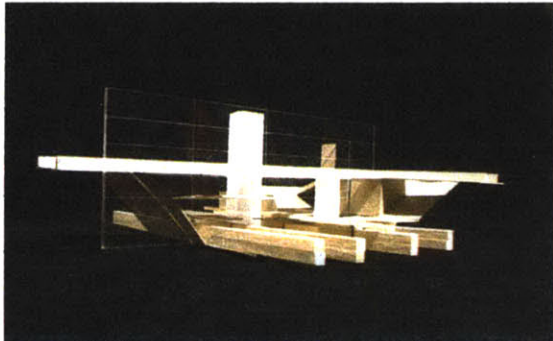

concept model diagramming transportation flow

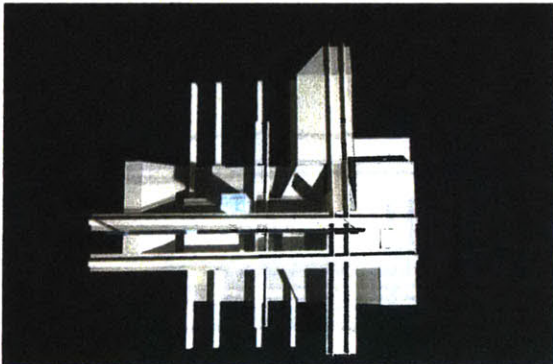

concept model diagramming transportation flow

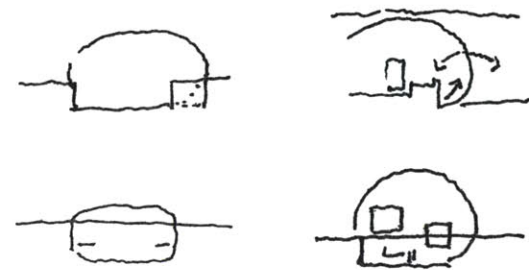
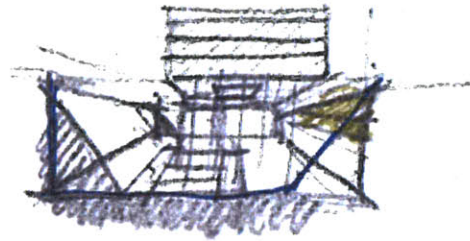
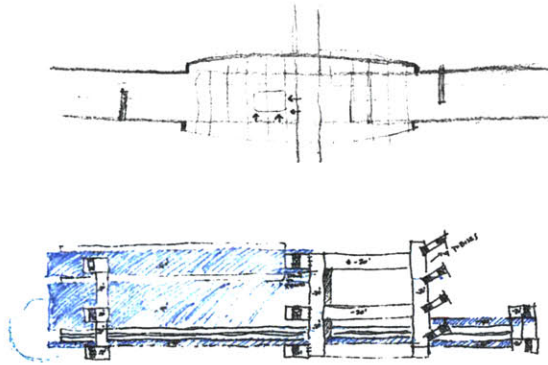

Concourse Level

rail lines

- commuter rail was longest element in station, centered on overpass
- MARTA rail was about half that size and could therefore be
- infusion of landscape
- points of rest/ reflection
- On a macro scale, stations should be organized such that users in transit can differentiate the inner city from the outer city.

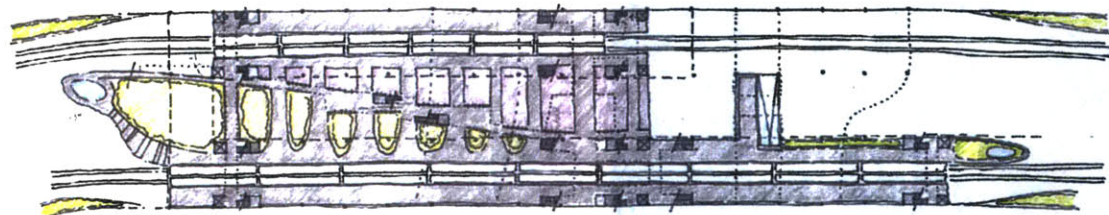
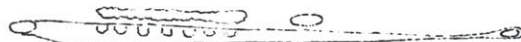
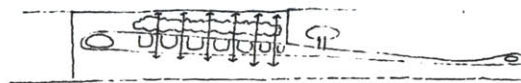
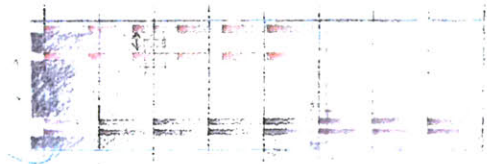

Scale 1/4" = 1'-0" 1/2" = 1'-0"

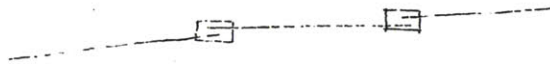

Transition Level

- intermediate circulation level
 - primarily longitudinal spine at -20'-0"
 - secondarily feeding levels at key locations
- places of rest
 - commercial
 - laundry

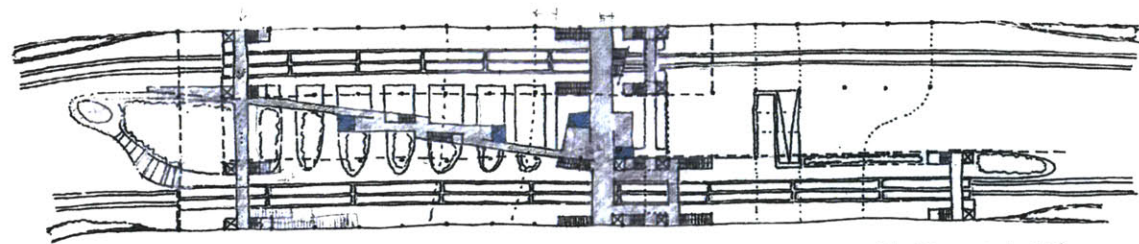
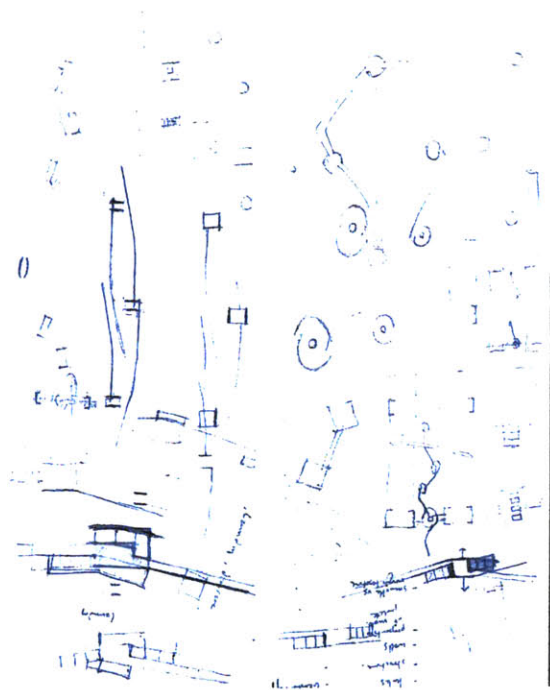

TRANSITION LEVEL LEVEL @ -20'-0"

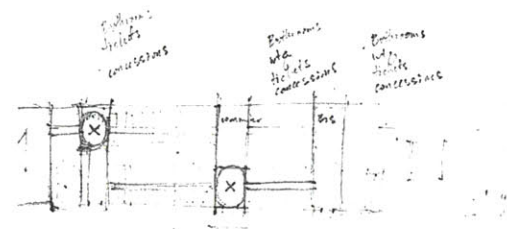
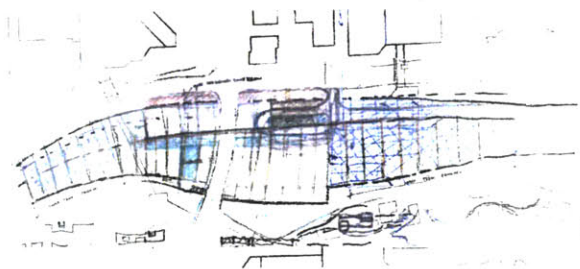
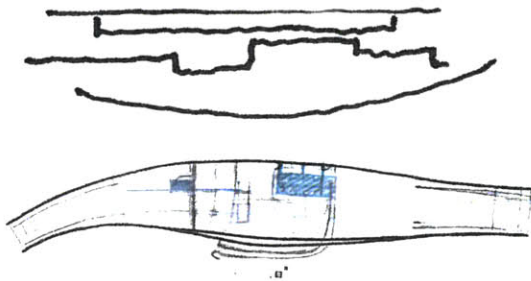

78

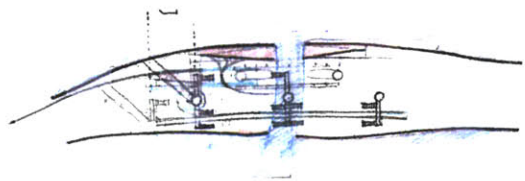

Ground Level

- main entrance
 - paving material extended out into city
- large sloped roof over tickets hall
 - tower at tickets
- buses
 - business side
- one-way
 - relatively long way from Lenox road to prevent car back up
 - tight and compressed

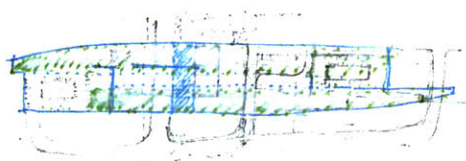
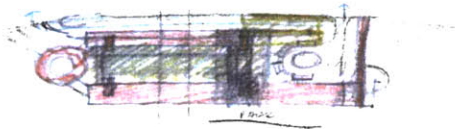
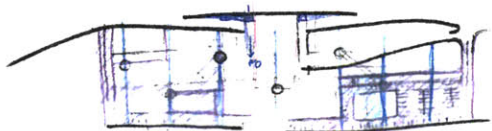

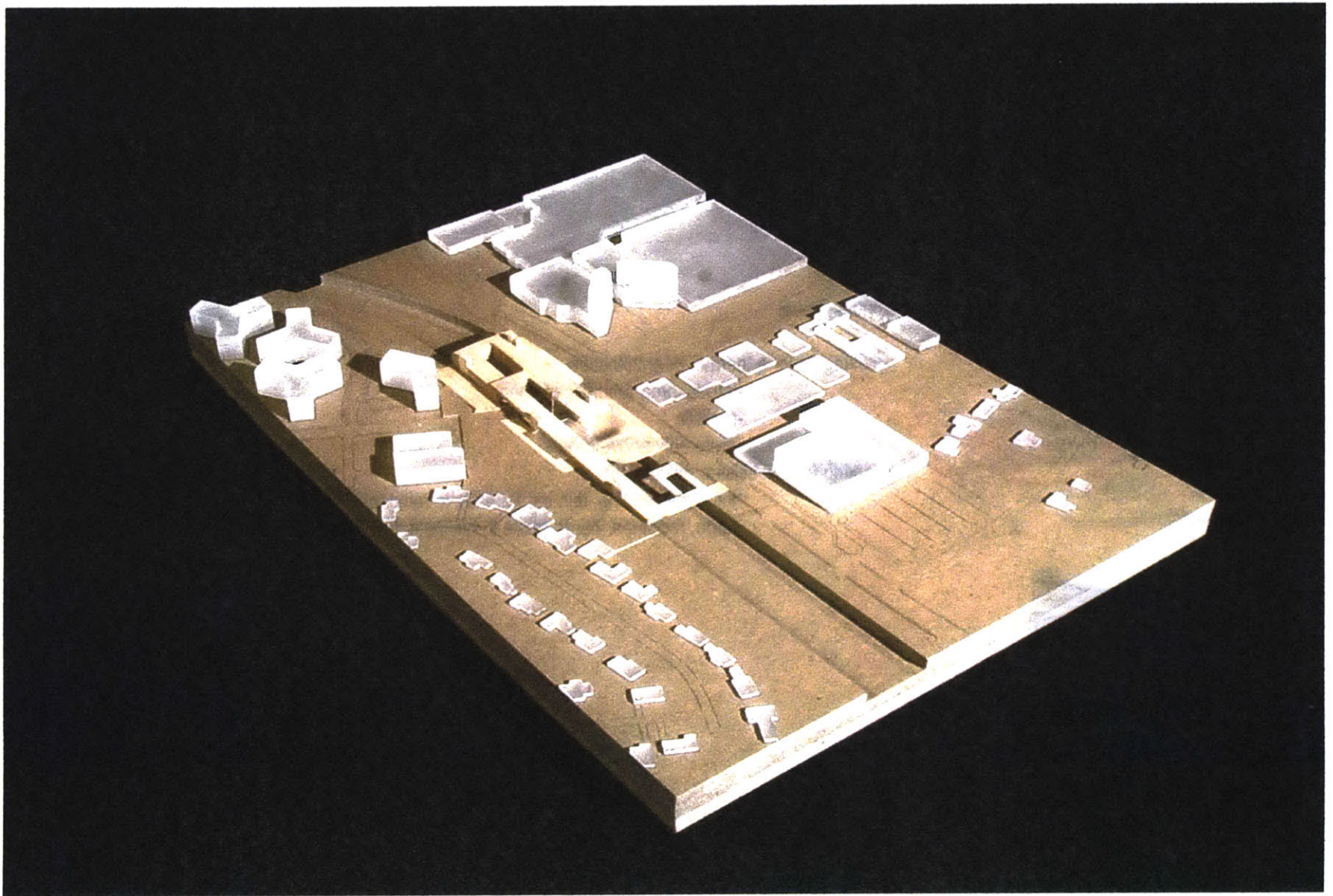

DESIGN EXPLORATION

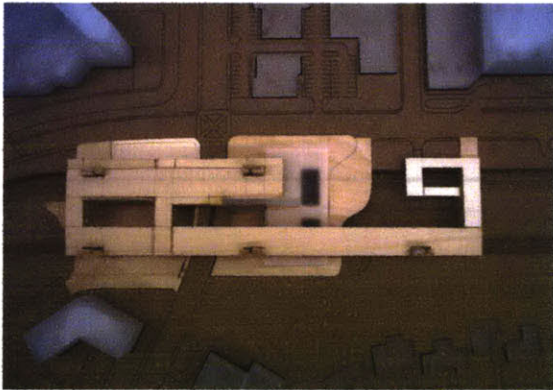
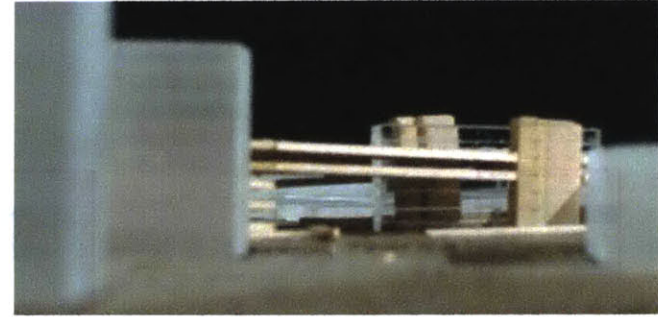
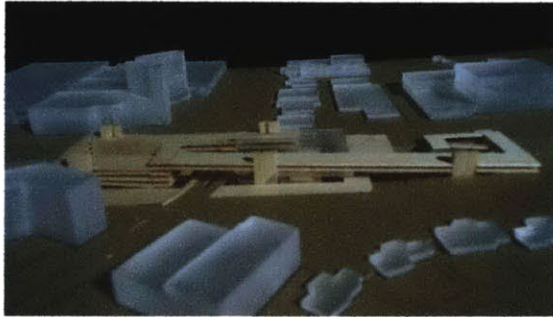

Site Model

chipboard, plexiglass, basswood, plastic

The intent of the site model was to show how the transit station would function as a positive connection and gateway to the Lenox community. The parking arrangement on model differs slightly from the final design in its east entrance. Otherwise, it is pretty similar.

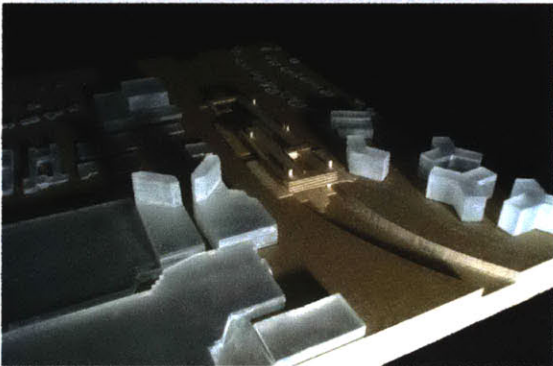

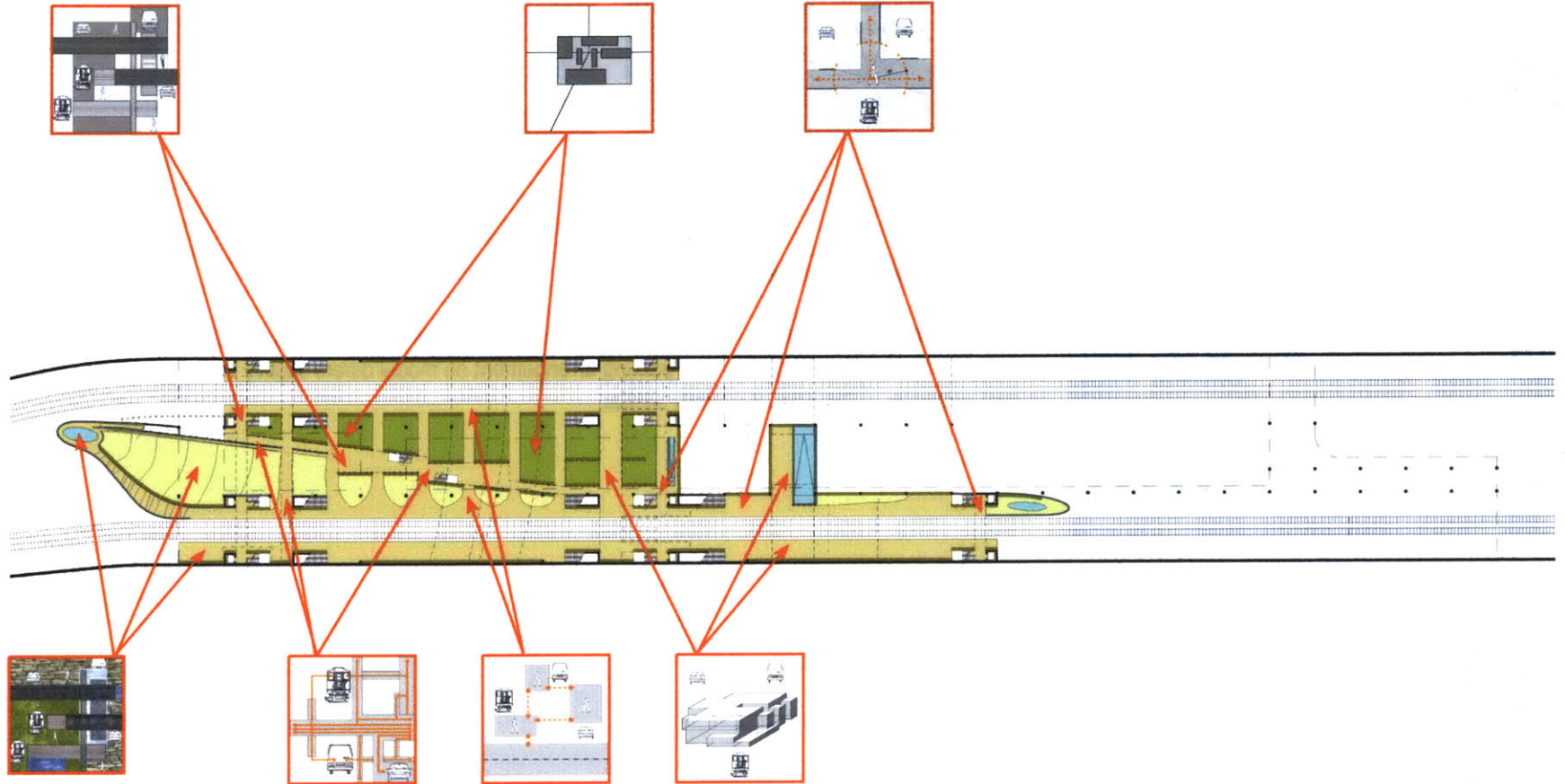

- metal
- asphalt
- slate
- stone
- wood
- section
- concrete
- water
- landscape
- wood

n
concourse level plan

DESIGN EXPLORATION

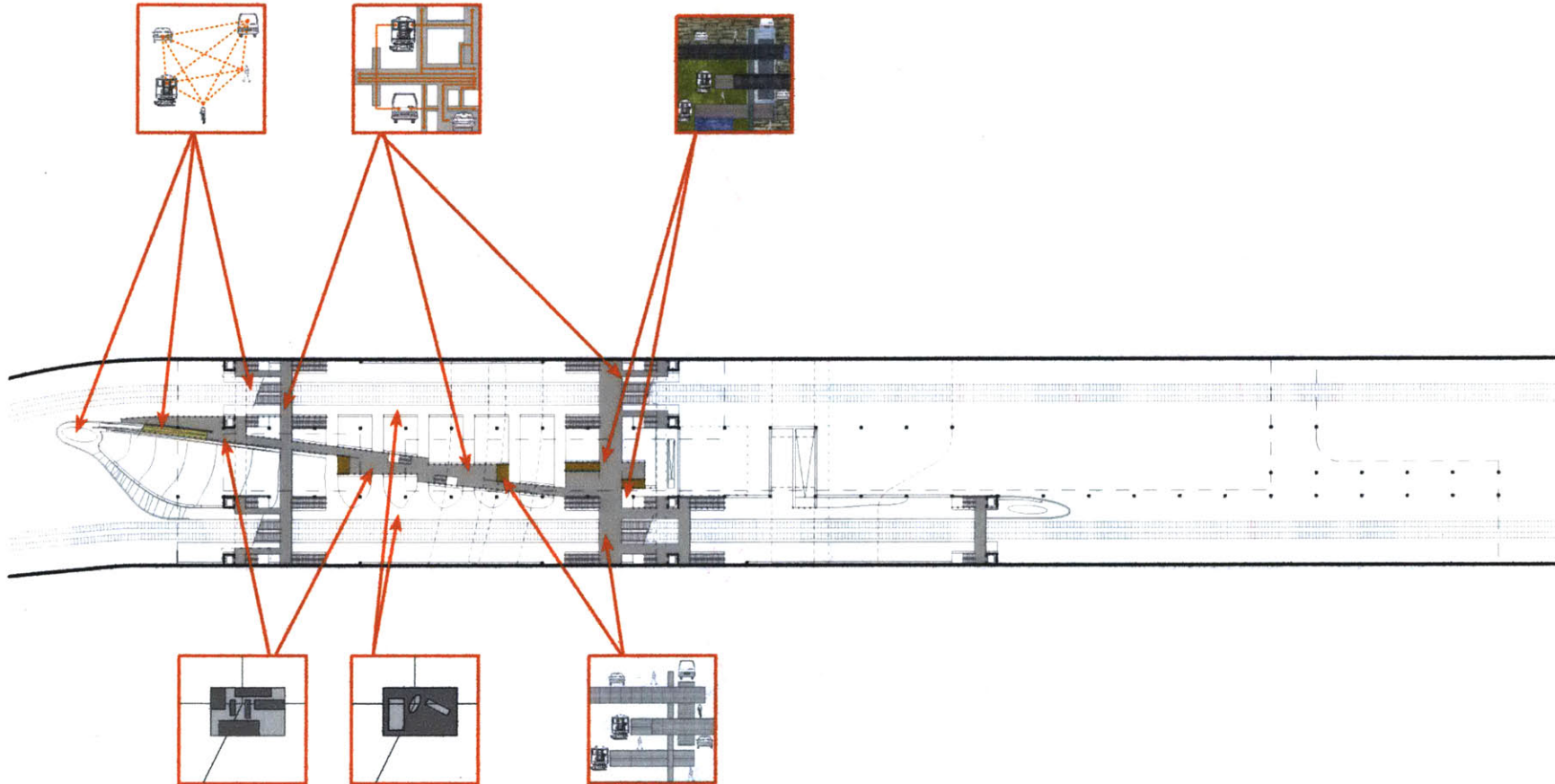

- | | | | | |
|---------|----------|-------|-----------|------|
| metal | asphalt | slate | stone | wood |
| section | concrete | water | landscape | wood |

n transition level plan

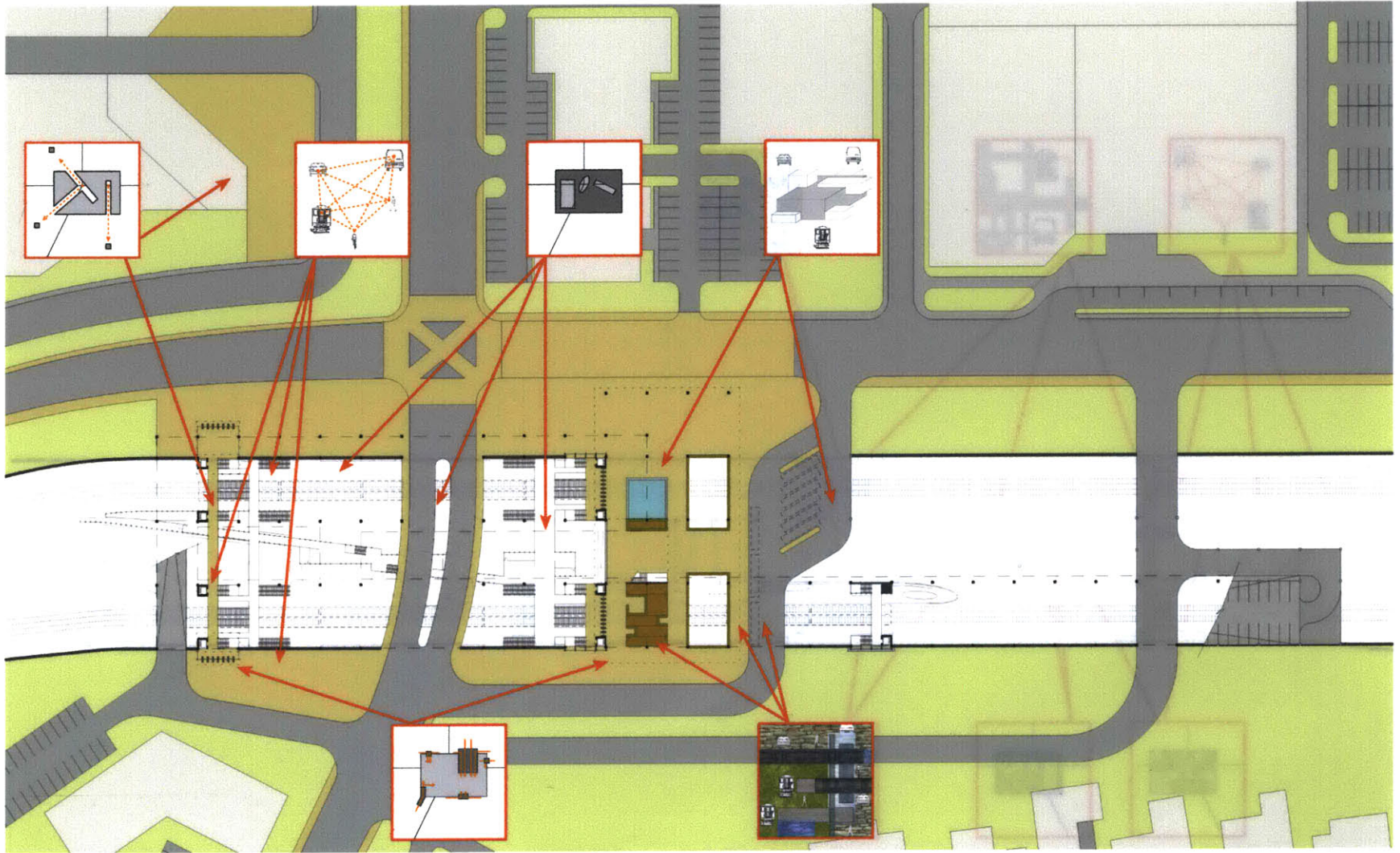

- metal
- asphalt
- slate
- stone
- wood
- section
- concrete
- water
- landscape
- wood

n ground level plan

DESIGN EXPLORATION

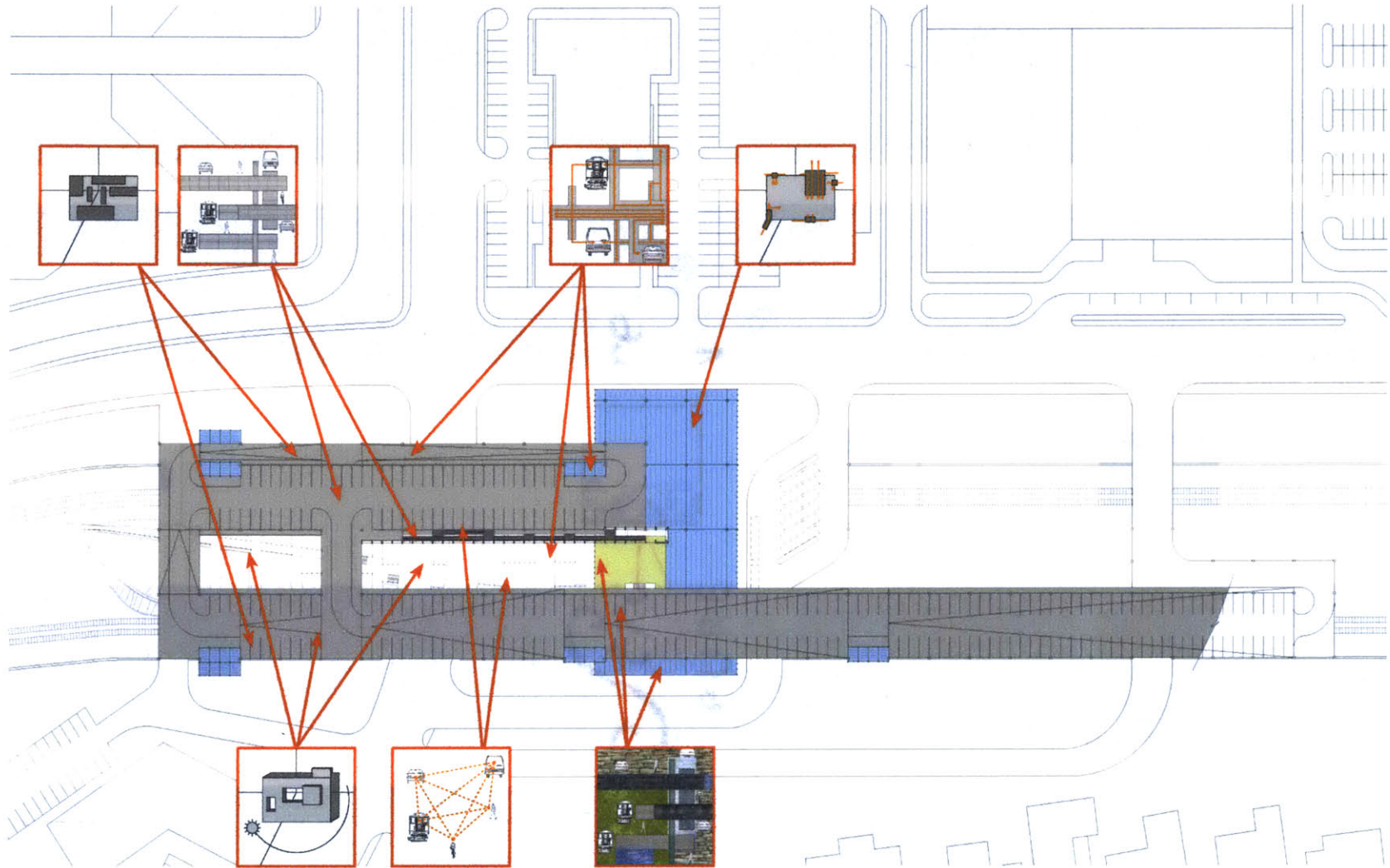

- | | | | | |
|---------|----------|-------|-----------|------|
| metal | asphalt | slate | stone | wood |
| section | concrete | water | landscape | wood |

n
 parking level plan

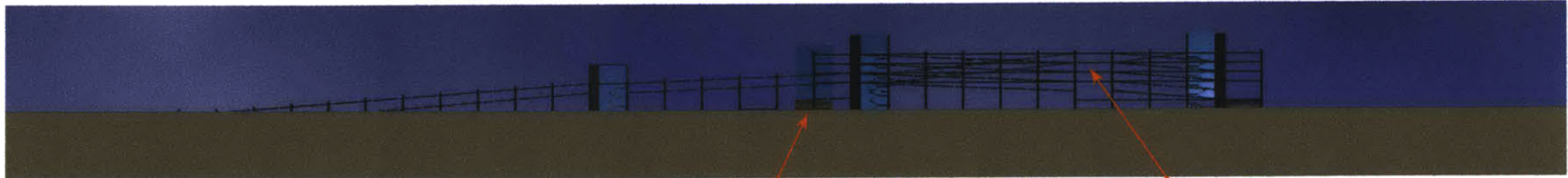

elevation looking south



lateral section looking south

86

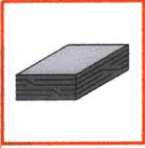
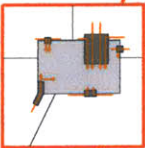

lateral section looking north



lateral section looking north

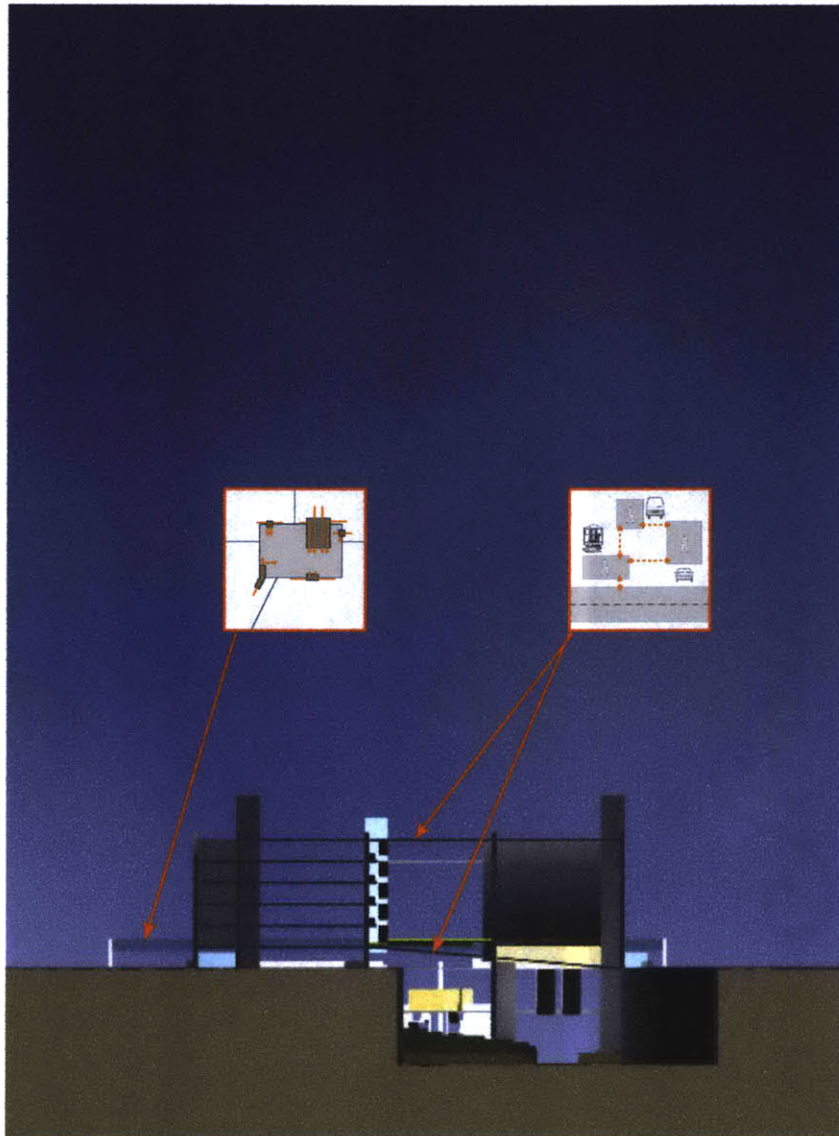

elevation looking east

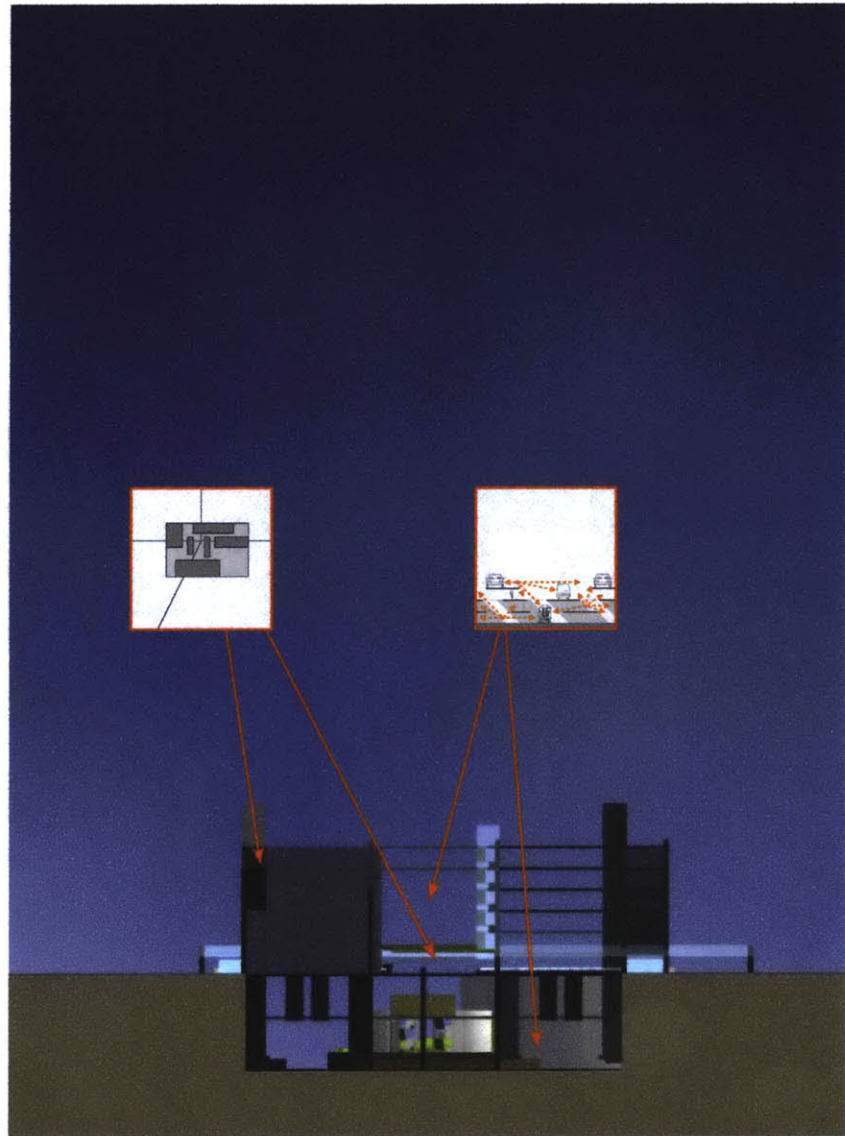

elevation looking west

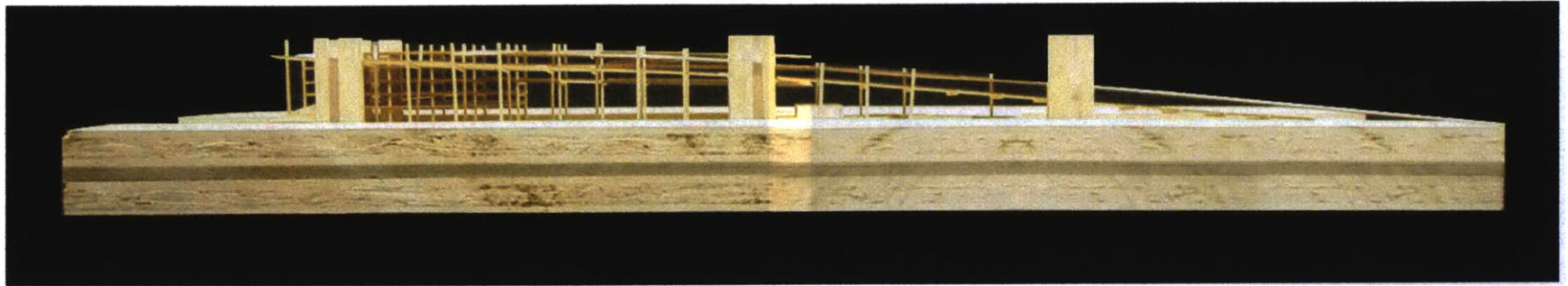

88

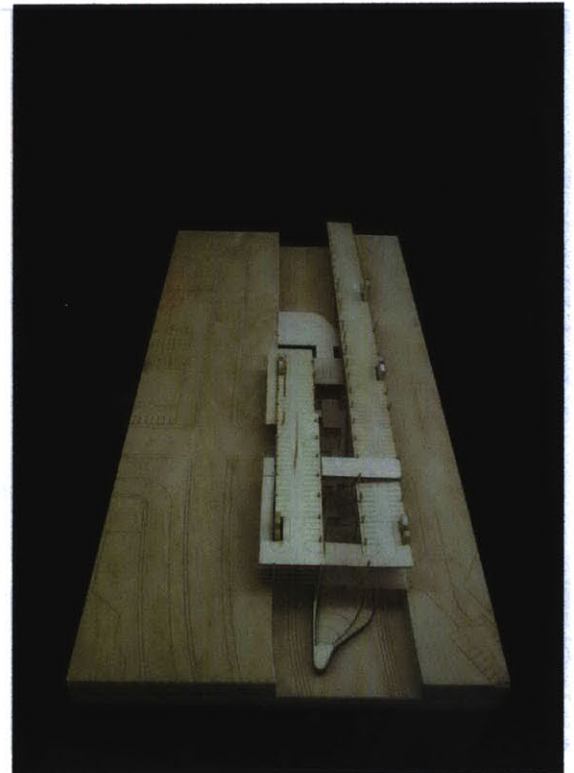
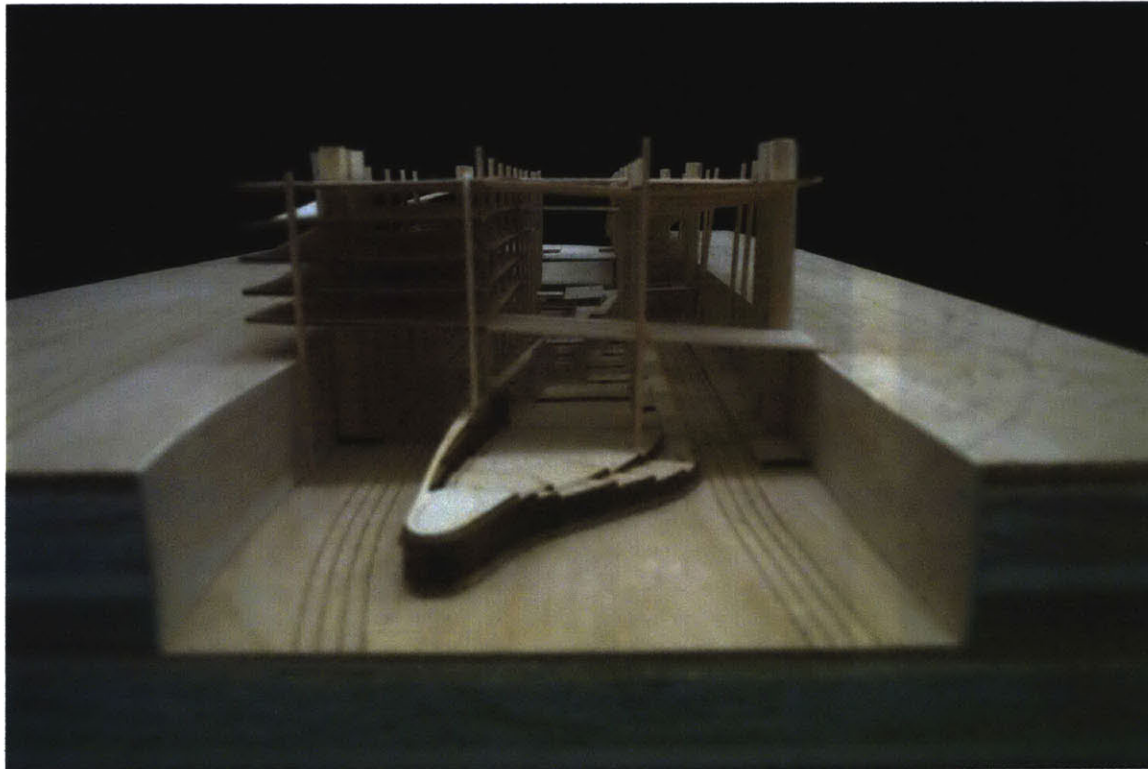

DESIGN EXPLORATION

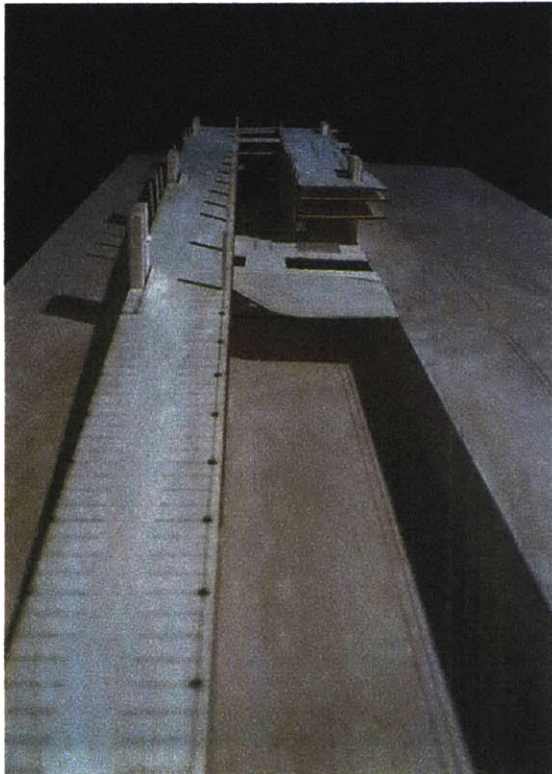
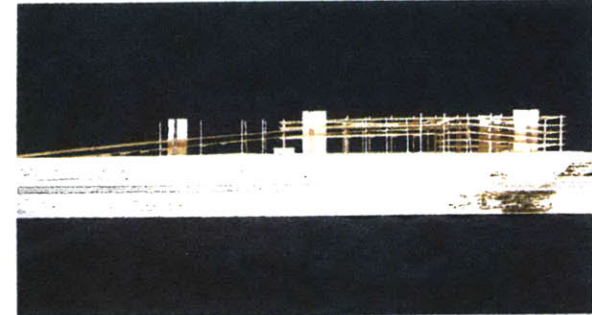
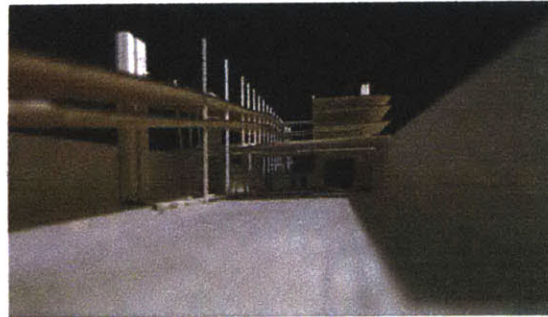
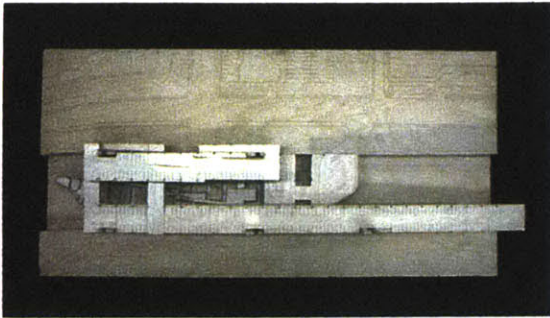

Final Model

basswood

The intent of the final model was to explore in greater detail the form of the building. This allowed a greater understanding of how the interior spaces and structure would facilitate wayfinding.

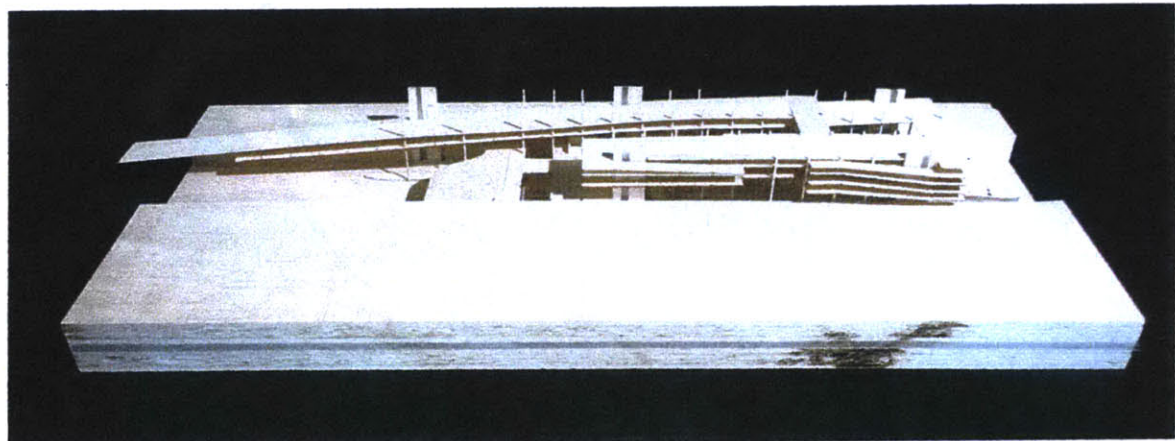

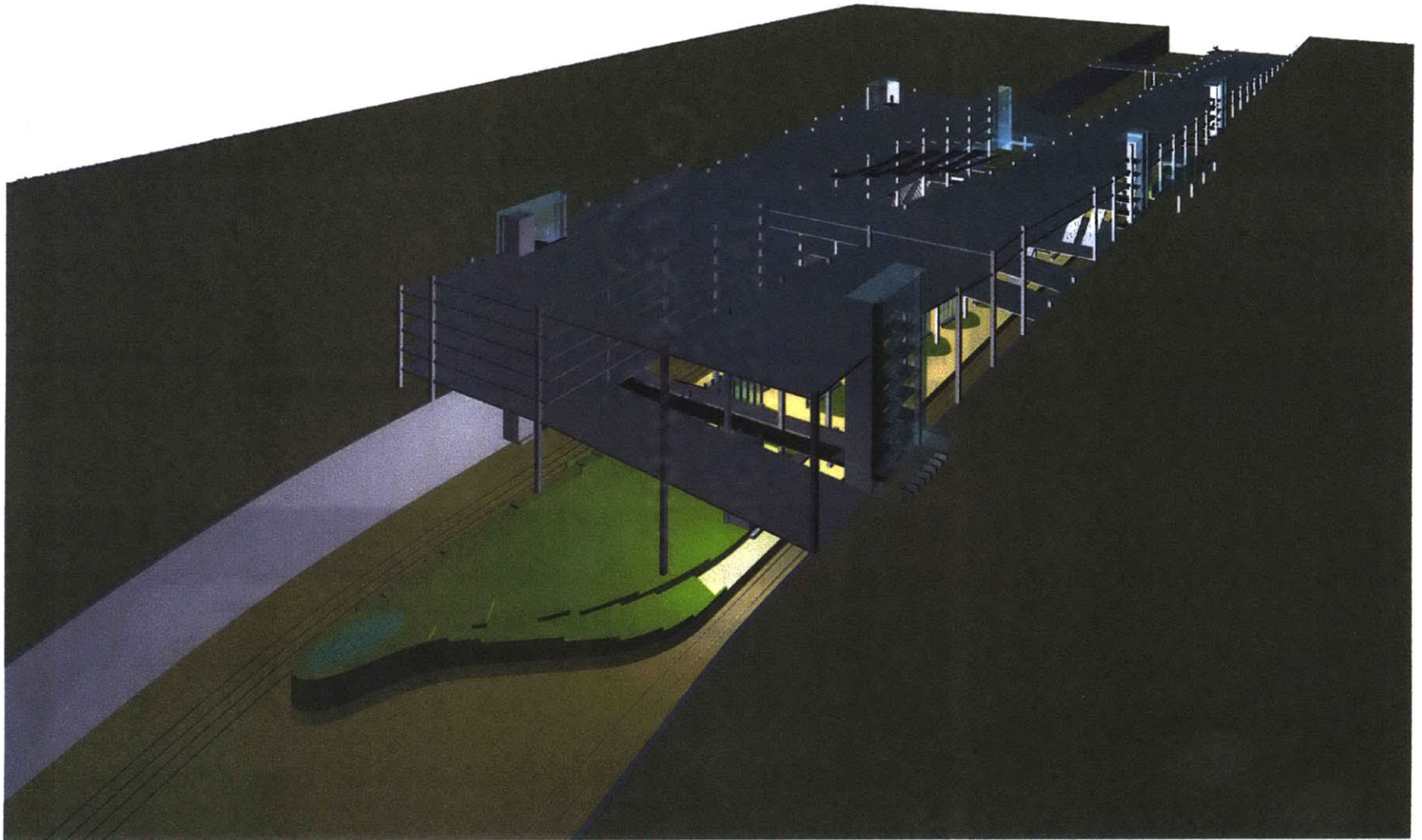

perspective looking northeast



axonometric view looking northwest

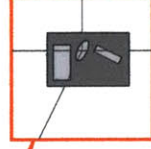
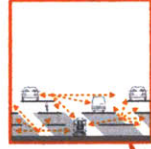
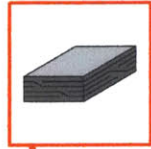
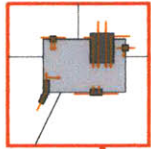

from street

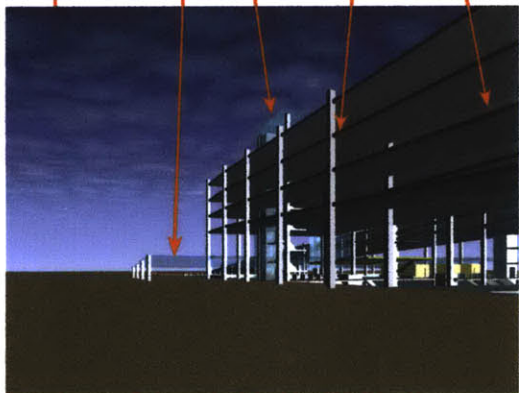

view from lenox mall to station main entrance

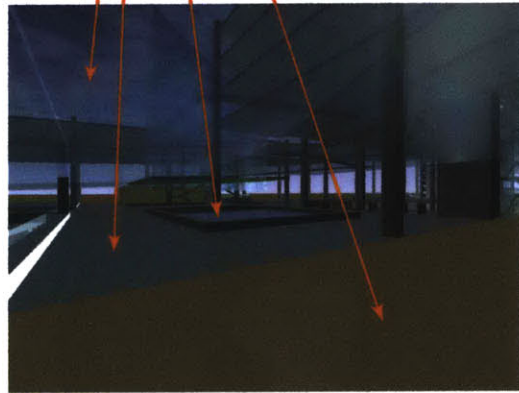

view from main entrance looking to tickets and turn-styles



view from entrance hall balcony looking down cat-walk

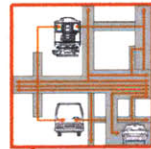

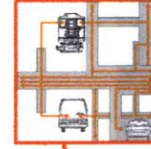
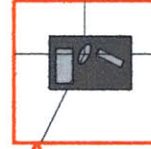
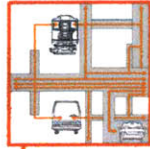
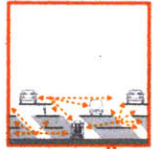

view from transition platforms looking over commuter rail

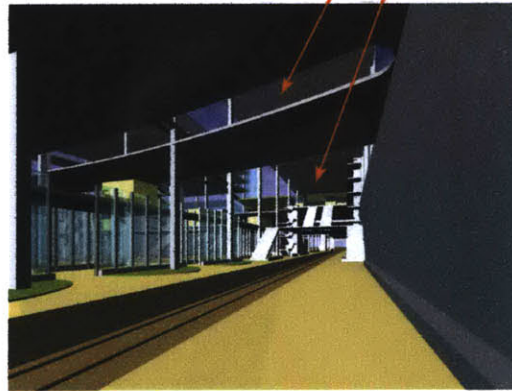

view from commuter rail platform under overpass

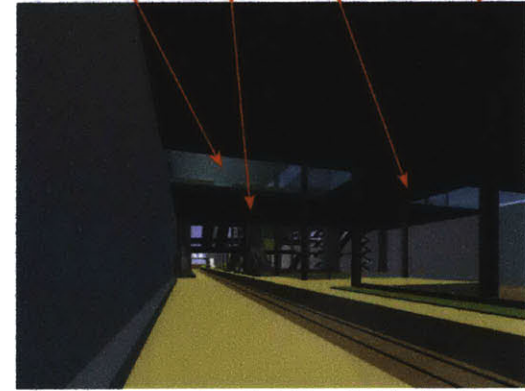

view from commuter rail platform looking back towards main entrance

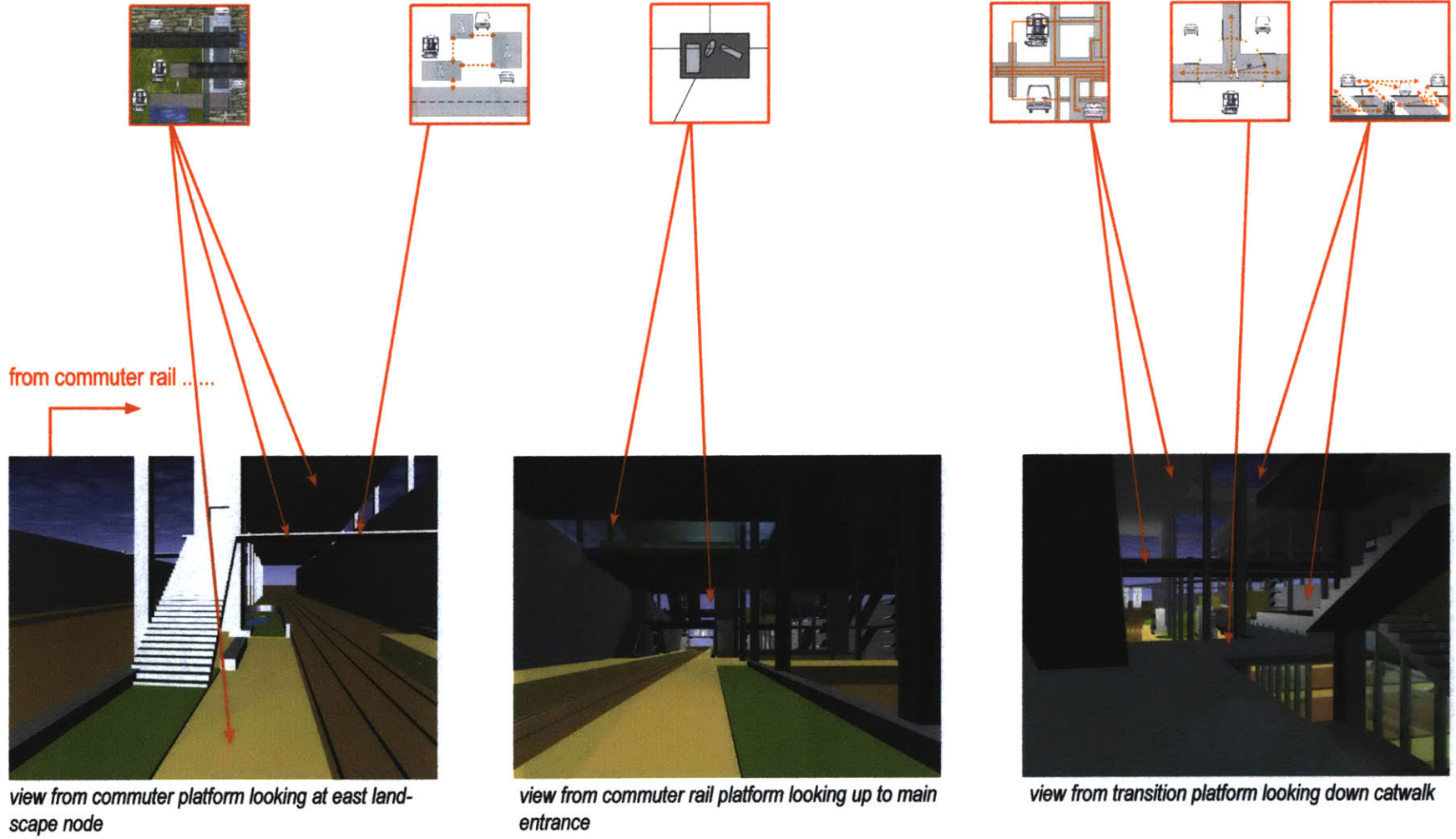

DESIGN EXPLORATION

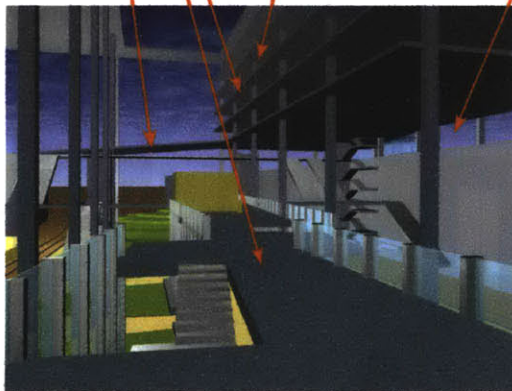
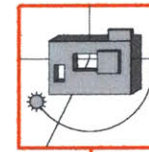
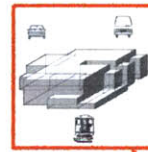
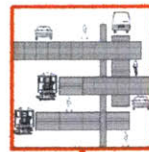
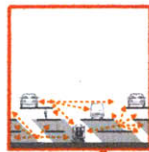
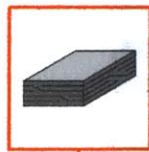

view from catwalk at central stairs looking down catwalk

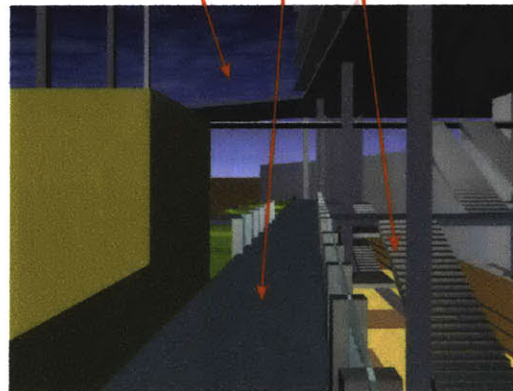

view from transition platform looking at west landscape node

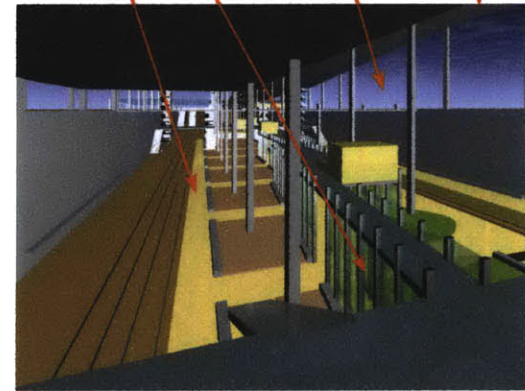

view from transition platform looking down onto MARTA rail

..... to MARTA rail



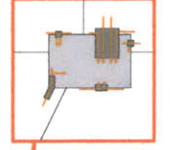
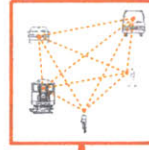
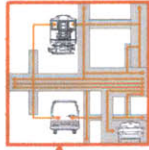
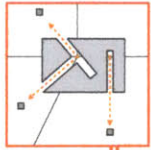

from parking

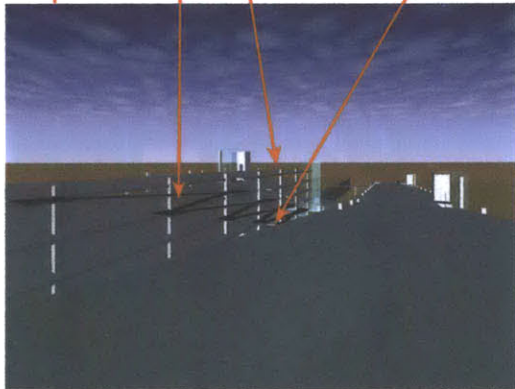

view from top of parking structure looking toward main entrance

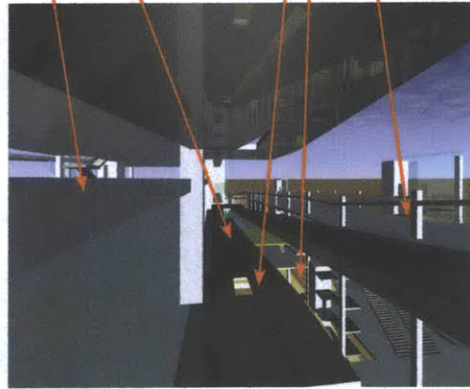

view from descension ramps looking toward main entrance

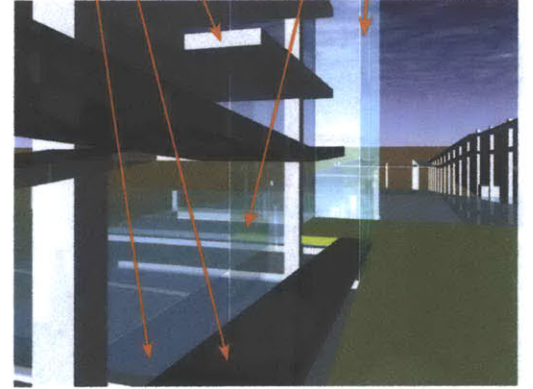

view from landscape roof looking back west over station

DESIGN EXPLORATION

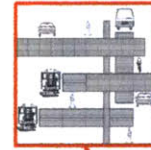
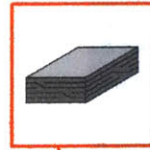
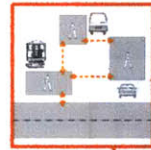
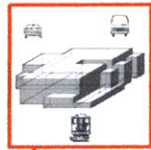

view from landscape roof looking back west over station

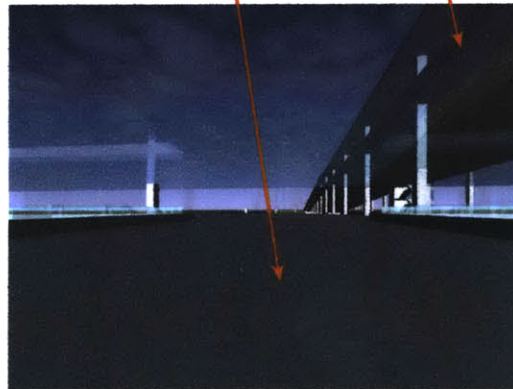

view from main entrance hall looking towards bus station

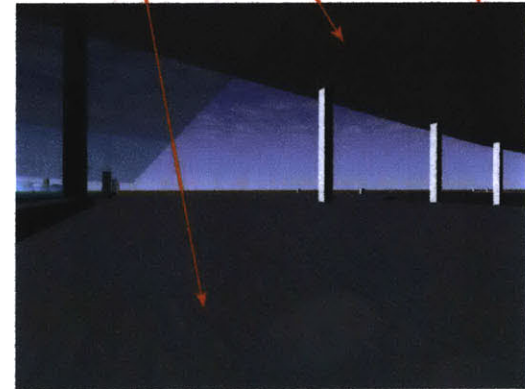

view from bus waiting platform looking towards bus entrance

..... to buses



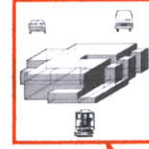
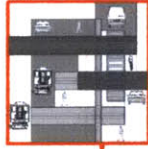
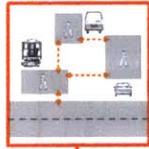

from primary entrance
(business side)

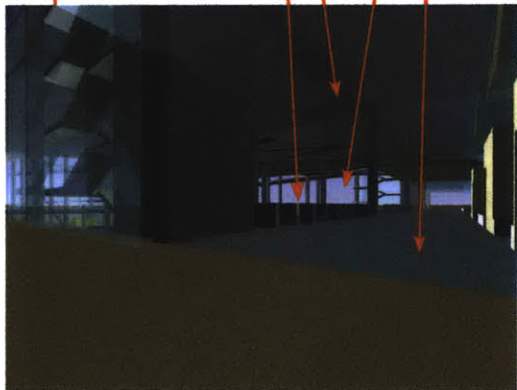

view from main entrance at south (residential side of station

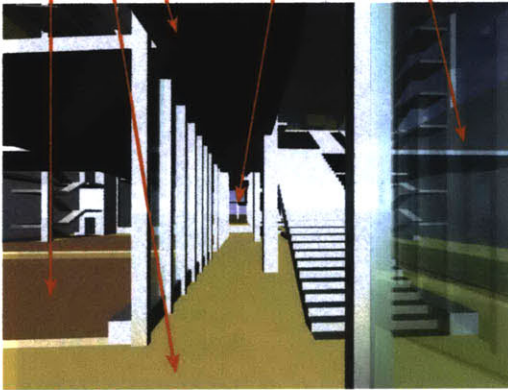

view from below catwalk looking down train level transition corridor

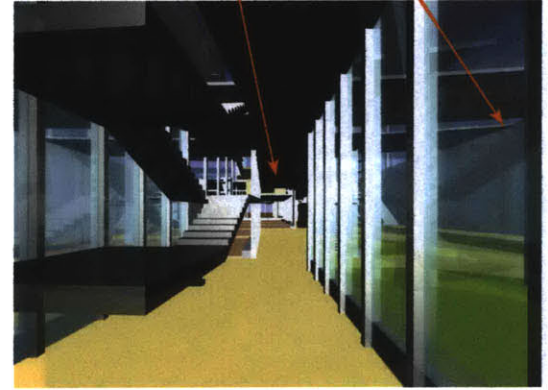

view from below catwalk looking up central catwalk stairs

DESIGN EXPLORATION

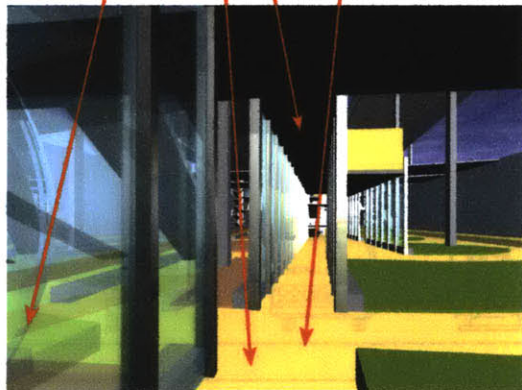
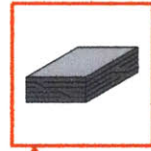
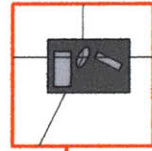
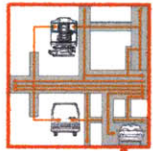

view from below catwalk looking toward commuter rail

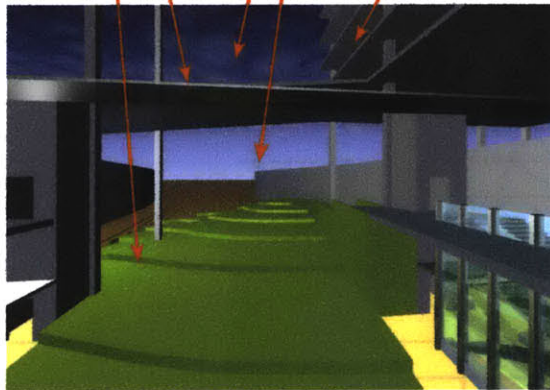

view from transition platform looking back toward west landscape node

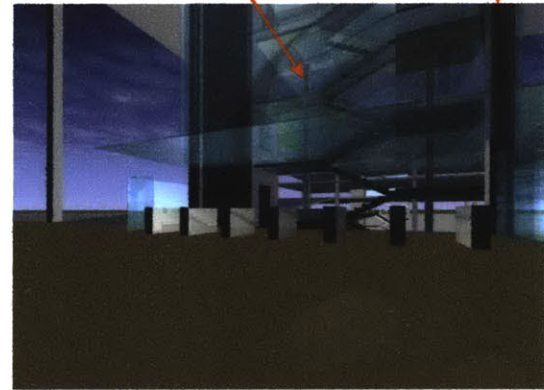

view from secondary station (near lenox mall) looking back

.... to secondary entrance (near lenox mall)

CHAPTER FIVE: FINDINGS AND CONCLUSIONS

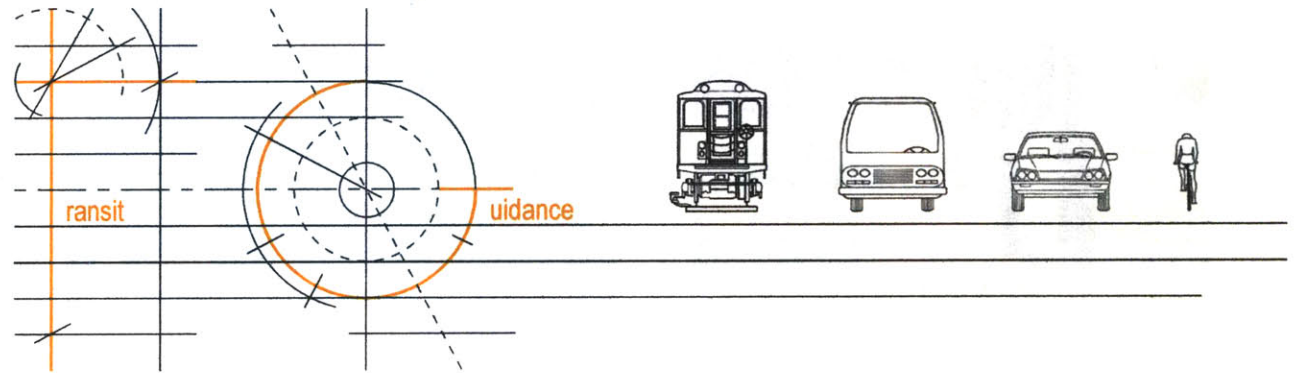

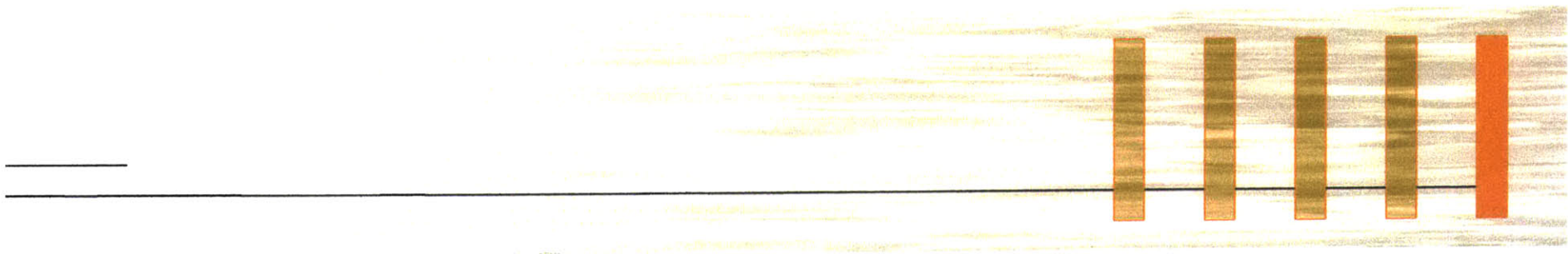

5.1 Personal Comments

This research project grew out of two deep interests I have: (1) how architecturally affecting our environments can affect the way we think and live and (2) what kind of architecture responses are appropriate for the dynamic qualities of public transportation spaces. Through investigating ways to combine these interests, the thesis objective evolved to focus on how architecture can solve the navigational problems typically associated with transportation spaces. I particularly wanted to look at applying my investigation to the recently emerging edge-city conditions, where I see the most exciting potential for transportation architecture in the next few years.

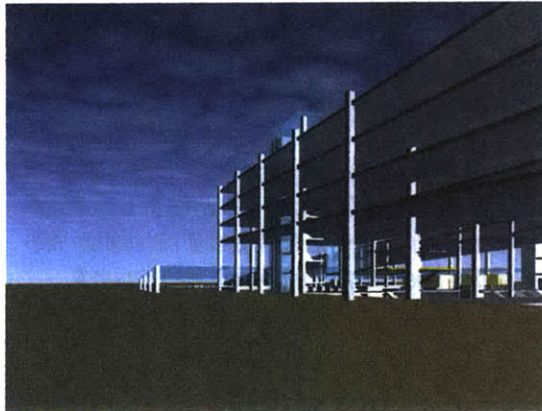
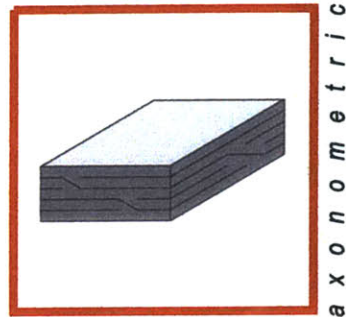

5.2 Primary Urban Design Proposition

103

DP-6 Expose the building section at the perimeter to reveal the interior organization from an urban distance. Where stations are sufficiently complex, this should occur on the interior as well.

Design Exploration: *From an urban scale, the most helpful indication of the building's function was the exposure of the parking section. Because of the scale of the parking and the fact that it bounded the site, this section could be seen from far away as well as from almost any direction.*

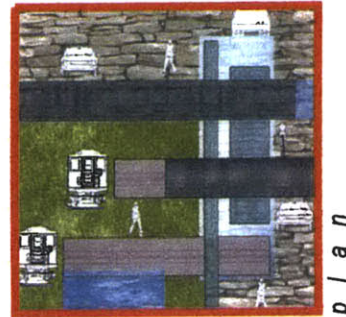
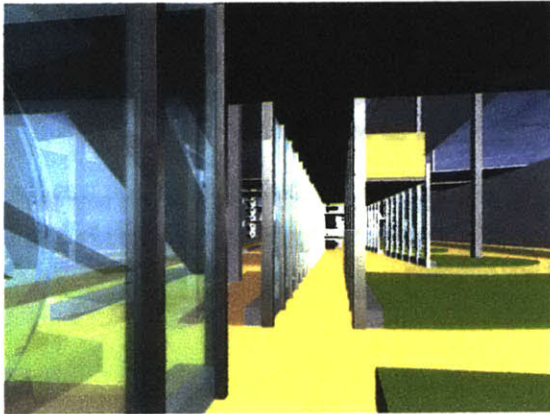

5.3 Primary Spatial Perception Proposition

[DP-12] Establish a logical system of material use in order to help delineate different kinds of modal and transition spaces. The materials should also be a sensitive response to who or what they are supporting.

Design Exploration: *In terms of spatial perception, materials played a particularly important role. Different kinds of landscape helped to signify waiting platform of different functions. Glass was a helpful in accentuating primary circulation routes. Also, wayfinding was aided by the contrast in the light metal circulation elements (indicating bridges or platforms) and the heavier stone paving (indicating connection with ground).*

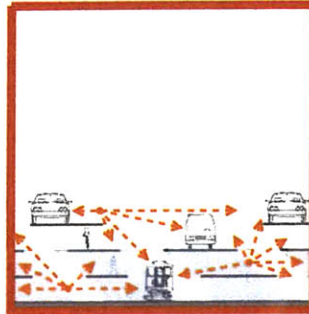

5.4 Primary Visual Access Proposition

105

DP-18 Establish regular vertical views between horizontal strata of the station. While it may not be possible to view the entire station from every vantage point, each significant domain should be visible from at least two other significant domains. “People like to look down on their world. The feeling of being able to view everything from above makes it easier to make objective decisions concerning direction. These vantage points become critical at decision points where the passengers can view level changes, transit systems or the direction to be taken to continue on to the next destination” (Alexander, 1969).

Design Exploration: *The many different penetrations within the station at different horizontal levels aided navigation throughout the station. While complete views were not always provided, the staggered circulation penetrations allowed ample natural light and orientation views.*

5.5 Findings and Conclusions

The following are findings and conclusions based on the initial thesis objectives (see section 1.6):

At a building scale, the layout of the circulation and waiting areas for the trains and buses is very efficient while the layout of many of the public circulation and the parking is somewhat inefficient. This arrangement seems to make sense in terms of wayfinding. Train and bus layouts are the most rigid while parking and pedestrian circulation are more flexible. As a result, those flexible elements were more influential in facilitating the wayfinding. In general, the large, unique elements such as the parking ring, the ticket tower, and the ticket hall glass roof were the elements that were the most useful elements from within the station.

The ground floor circulation was the most obstructive to wayfinding. The buses were probably the most difficult to perceive from the trains because there were few elements that indicated their function from below. The ticket tower was difficult to perceive from some places below the ground circulation. Also, the MARTA line platforms were obstructed by much of the public space at ground level, particularly in the bus domain. However, in all cases, the circulation leading to these areas was relatively clear because of the large volumes of open space throughout.

Furthermore at the building scale, landscape proved to be a critical element in terms of wayfinding by making the spaces more inviting as well as enriching the overall architectural character. It helped significantly at the train level to differentiate different kinds of public spaces. Water was found to be a useful element at strategically located places of rest. These spaces would promise to enrich the waiting and the transition experiences of users, thus making them more memorable.



A space of reflection while waiting for trains, located at the east end of the station

At a community scale, the station successfully establishes itself as a landmark, visible from many different vantage points in the community. As proposed earlier, parking does seem to make the most sense as the major generator of the architecture, given the dominance of the automobile on the site. From the exterior, the parking scheme was somewhat successful in that its form not only adjusted based on site conditions but also implied the form implied the interior functions of the transit station. Also, the form did establish itself as gateway to the Lenox Community, reinforcing the site as a node of activity. From a negative standpoint, the parking scheme was somewhat excessive both in form and scale. While it could have been more sensitive to the exterior context, this thesis concludes that being excessive to an extent is still worth the extra cost for the sake of the wayfinding benefit gained.

107

In addition, at a community scale, the station successfully knits the site together through circulation. Whereas pedestrian circulation was originally only available by crossing the thin overpass sidewalks, these sidewalks have been widened and pedestrian circulation now spans the site at the far west end of the station, at the main ticket hall, and at the bus waiting platform. The last three of these areas are wider and are protected from the busy road traffic. In addition, the buses circulate more efficiently at ground level, where as before they had to extend under the overpass. This move also helps them to be more visible from an urban distance. Finally, parking is more accessible. Before it was two blocks east of the nearest station entry and now it is directly above the station.

In addition, the design scheme knits the site together through materials. Although landscape was destroyed by the creation of the station train trench, nature was given back to the interior spaces through vegetation and water at various levels allowing the station to visually blend a bit more with its exterior conditions. Also, light

brown stone indicating pedestrian paths extends from the station interiors out to the city through plazas and road paving, inviting users inside.

From a network scale, the least was learned about wayfinding because the bulk of the exploration was focused on the community and architectural scales. However, there were some promising outcomes in this area that would be interesting to explore further. Some of the larger architectural moves such as the massive courtyard established by the parking and the long stretch of landscape might serve to facilitate perception of the city from the moving trains at a network scale. Both the parking and landscape gradually rise or descend (depending upon the point of view) as the trains pass through the station. While all of the stations could have an architecturally different language that adjusts according to each unique site, if they all had the same kind of general upward thrust in the same direction, this would remind riders at each station of the direction their train is traveling (i.e. "clockwise around the city" or "away from the city center"). This reminder would be most useful in complex systems where routes tend to inter-weave. The different qualities of landscape on either side of the station could have a similar effect. As riders passed by each station, if one side of each location had a more rigid landscape while the other side always had a more organic landscape, then this would reinforce what side of the city a traveler is traveling on (i.e. "on the inside of the perimeter ring")

Also at this scale, the station successfully facilitates many views of the exterior context from within the interior. This is primarily because the parking scheme is generally raised at least one level above ground to allow for a viewing slot one story in height along much of the station length. This scheme allows for much of the exterior context to be visible from within the station at ground level and for tall nearby buildings to act as visible landmarks, even from below ground level. In this way, users can employ the unique characteristics of each

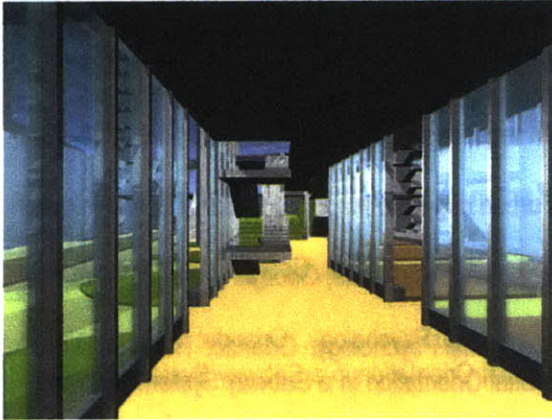

surrounding site to help them navigate as they move through the station.

109

Finally, at a network scale, the station design begins to imply how a network of public spaces in different stations could be related through various secondary programs. This could help to reinforce the collective mental image by drawing people to sites to which they would not otherwise go. In the design exploration scheme, these elements were placed at the main ticket hall and in the middle of the catwalk (two transition spaces where one might want to rest for a minute anyway) but they could have been located elsewhere as well. One could imagine a mall-like series of multi-modal stations, each with a different combination of secondary program elements. As a result, an individual living near one station might take the train to another station to drop off the dry-cleaning, to another to get a haircut, and still another to buy groceries. If these secondary programs were located in ways that facilitated wayfinding (such as by framing views of exterior landmarks) then they could work with the other station architecture to support the collective mental image of the city.

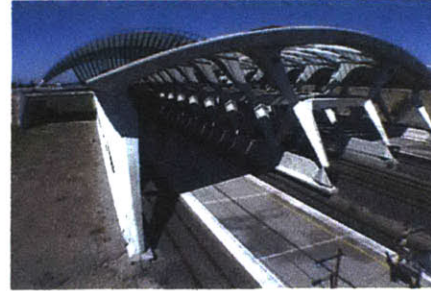
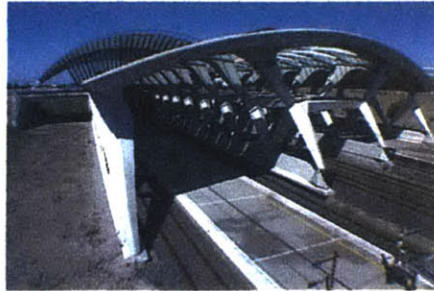

BIBLIOGRAPHY

110

- Aben, R.** (1999) *The Enclosed Garden: History and Development of the Hortus Conclusus and its Reintroduction into the Present-day Urban Landscape*. Rotterdam: 010 Publishers.
- Anderson, J.R. and Bower, G.H.** (1973). *Human associative memory*. Washington, DC: Winston.
- Alexander, C. (1969) "Major changes in environmental form required by social and psychological demands". *Ekistics*, 28, pp. 78-85.
- Aragones, J.I. and Arredondo, J.M.** (1985). "Structure of urban cognitive maps". *Journal of Environmental Psychology*, 5, pp. 197-212.
- Beck, R.** (1983) *Wayfinding in Subway Systems*. Unpublished Master's thesis, Georgia Institute of Technology.
- Bell, P., Fisher, J., Baum, A., and Green, T.** (1996) *Environmental Psychology*. Orlando: Harcourt Brace.
- Bronzaft, A. L., Dobrow, S., and O'Hanlon, T.** (1976) "Spatial Orientation in a Subway System." *Environment and Behavior*, vol 8, no 4.
- Byrne, R. W.** (1979) "Memory for Urban Geography". *Quarterly Journal of Experimental Psychology*, 31, pp.147-154.
- Canter, D.** (1982) "Way-Finding and Sign-Posting: Penance or Prosthesis?" Appearing in Conference Book: *Visual Presentation of Information, the NATO Conference for Visual Presentation of Information*, The Netherlands: Hetvennebos.
- Cantilli, E.J. and Fruin, J.J.** (1972) "Information Systems in Terminals." *Traffic Quarterly*, April.
- Cohen, S., Evans, G. W., Stokols, D., and Krantz, D.S.** (1986) *Behavior, health and environmental stress*. New York: Plenum.
- Cornodoli, C., and McDaniel, M.A.** (1991) *Imagery and cognition*. New York: Springer.
- Cortie, C.** (1994) "De Ruimtelijke Structuur van Post-Industrieel Amsterdam, een Ontwikkeling naar Ameri-

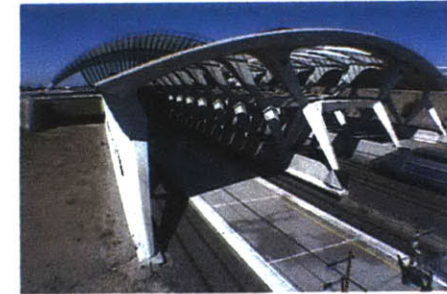
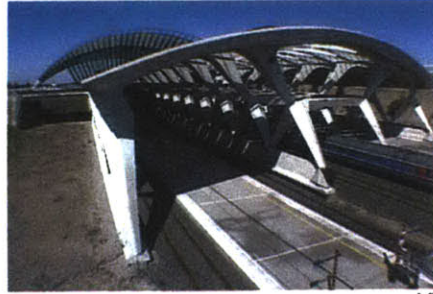

Video sequence of high-speed train passing through Satolas Station

caans Model?" Camstra, R., A. Goethals, and S. Musterd, *Maatschappelijke Dynamiek en de Ruimtelijke Afstemming van Wonen en Werken*. Amsterdam, SISWO. pp. 15-33.

Dagenhart, R. (1995) "Invisible visible". Atlanta, Jordi Bernadó, Barcelona: Actar Produccions, pp. 20-27.

Devlin, A. S. (1976) "The small-town cognitive map: Adjusting to a new environment". In G.T. Moore & R.

G. Golledge (Eds.) *Environmental knowing: Theories, Research, and Methods*, Stroudsburg, PA: Dowden, Hutchinson, & Ross.

Duthilleul, J. (1998) *Agence des Gares AREP: Parcours 1988-1998*. Rome: Diagonale.

Evans, G. W. (1980) "Environmental cognition". *Psychological Bulletin*, 88, pp. 259-287.

Fruin, J. J. (1971) *Pedestrian Planning and Design*. New York: Metropolitan Association of Urban Designers and Environmental Planners, Inc.

Gärland, T., Böök, A., and Lindberg, E. (1986) "Spatial Orientation and Wayfinding in the designed environment. A conceptual analysis and some suggestions for postoccupancy evaluation". *Journal of Architectural Planning Research*, 3, pp. 55-64.

Garreau, J. (1991). *Edge City*. New York: Doubleday.

Glicksohn, J. (1994). Rotation, orientation, and cognitive mapping. *American Journal of Psychology*, 107, pp. 39-51.

Gordon, P. and Richardson, H.W. (1996) "Beyond Polycentricity" the Dispersed Metropolis, Los Angeles 1970-1990, *Journal of the American Planning Association*, vol. 62, no.3

Gravel, R. (1999) "Design of Cities- Design of Infrastructure". Unpublished summary of Master's Thesis: Belt Line- Atlanta, Design of Infrastructure as a Reflection of Public Policy , Georgia Institute of Technology

Hoel, L. A. and Richards, L. G. (1980). *Planning Procedures for Improving Transit Station Security*, Washington, DC: U.S. Department of Transportation

- Hunt, M. E.** (1984). "Environmental learning without being lost there". *Environment and Behavior*, 16, pp. 307-334.
- Jacobs, M.** (2000) *Multinodal Urban Structures. A Comparative Analysis and Strategies for Design*. Delft: Delft University Press.
- Kaplan, S.** (1976) "Adaptation, Structure and Knowledge." In G.T. Moore and R.G. Golledge (eds.). *Environmental Knowing: Theories, Research, and Methods*, Dowden, Hutchinson and Ross, Inc. Strousburg, PA
- Koolhaas, R.** (1995) "Atlanta: A Reading." *Atlanta*. Jordi Bernadó , Barcelona: Actar Produccions., pp. 74-85.
- Kosslyn, S. M.** (1975) "Information representation in visual images". *Cognitive Psychology*, 7, pp. 341-370.
- Lynch, K.** (1960) *The Image of the City*. Cambridge: The MIT Press.
- Passini, R.** (1984) "Spatial representations, a wayfinding perspective". *Journal of Environmental Psychology*, 4, pp.153-164.
- Pylyshyn, Z. W.** (1973) "What the mind's eye tells the mind's brain: a critique of mental imagery. *Psychological Bulletin*, 80, pp. 1-24.
- Pylyshyn, Z. W.** (1981) "The imagery debate: Analogue media versus tacit knowledge". *Psychological Review*, 88, pp. 16-45.
- Rapport, A.** (1976) "Environmental Cognition in Cross-Cultural Perspectives." In G.T. Moore and R.G. Golledge (eds.). *Environmental Knowing: Theories, Research, and Methods*, Strousburg, PA: Dowden, Hutchinson & Ross, Inc.
- Richardson, H.W.** (1988) "Monocentric vs. Polycentric Models: the future of Urban Economics in Regional Science." *The Annals of Regional Science*, Washington: Bellinghaus.



Avignon Station

Seghers, Pierre. (1993) *Piranesi*. trans. Ian Higgins. London, Forest Books.

Seidel, A. (1982) Professor, University of Texas, Austin, Texas. Interview, April 13

Stea, D. (1976) "Program Notes on a Spatial Fugue." In G. T. Moore and R. G. Golledge (eds.), *Environmental Knowing: Theories, Research, and Methods*, Stroudsburg, PA: Dowden, Hutchinson, and Ross, Inc.,

Stilitz, I.B. (1970) "The Role of Static Pedestrian Groups in Crowded Spaces." *Ergonomics*, vol 12, no 6.

Weisman, J. (1979) *Way-finding and the built environment: a study in architectural legibility*. Unpublished Doctoral Dissertation, University of Michigan.

Winkel, G. H. and Hayward, G. D. (1971) "Some Major Causes of Congestion in Subway Stations," City University of New York.

FIGURE CREDITS

114

Unless otherwise noted, all images are the author's

1. Canary Wharf. Recieved in interview with Megan Yakeley, Foster and Partners Press pack 2002.
2. Piranesi drawing from *Seghers, Pierre*. (1993) Piranesi. trans. Ian Higgins. London, Forest Books.
3. Primary and Secondary Cognition from Bell, P., Fisher, J., Baum, A., and Green, T. (1996) *Environmental Psychology*. Orlando: Harcourt Brace.
4. Cognitive Factors in Wayfinding from Bell, P., Fisher, J., Baum, A., and Green, T. (1996) *Environmental Psychology*. Orlando: Harcourt Brace.
5. Spatial Cognition model from Bell, P., Fisher, J., Baum, A., and Green, T. (1996) *Environmental Psychology*. Orlando: Harcourt Brace.
6. Shortcut routes from Bell, P., Fisher, J., Baum, A., and Green, T. (1996) *Environmental Psychology*. Orlando: Harcourt Brace.
7. Cognitive Maps from Bell, P., Fisher, J., Baum, A., and Green, T. (1996) *Environmental Psychology*. Orlando: Harcourt Brace.
8. A Texan's map from Bell, P., Fisher, J., Baum, A., and Green, T. (1996) *Environmental Psychology*. Orlando: Harcourt Brace.
9. Non perpendicular intersection from Bell, P., Fisher, J., Baum, A., and Green, T. (1996) *Environmental Psychology*. Orlando: Harcourt Brace.
10. Sketchmap from Bell, P., Fisher, J., Baum, A., and Green, T. (1996) *Environmental Psychology*. Orlando: Harcourt Brace.
11. Lynch's elements from Lynch, K. (1960) *The Image of the City*. Cambridge: The MIT Press.
12. Lynch diagram of Boston from Lynch, K. (1960) *The Image of the City*. Cambridge: The MIT Press.



Figure 53 - Metro Station

13. Lynch diagrams from Lynch, K. (1960) *The Image of the City*. Cambridge: The MIT Press.
14. Quincy Market from Bell, P., Fisher, J., Baum, A., and Green, T. (1996) *Environmental Psychology*. Orlando: Harcourt Brace.
15. You-are-here-map from Bell, P., Fisher, J., Baum, A., and Green, T. (1996) *Environmental Psychology*. Orlando: Harcourt Brace.
16. Wayfinding scenario from Bell, P., Fisher, J., Baum, A., and Green, T. (1996) *Environmental Psychology*. Orlando: Harcourt Brace.
17. Urban concentration diagrams
18. Transit diagram from Lynch, K. (1960) *The Image of the City*. Cambridge: The MIT Press.
19. Subway netherworld from Lynch, K. (1960) *The Image of the City*. Cambridge: The MIT Press.
20. Spaghetti Junction from (1995) "Atlanta: A Reading." Atlanta. Jordi Bernadó, Barcelona: Actar Productions
21. Atlanta transportation line from (1995) "Atlanta: A Reading." Atlanta. Jordi Bernadó, Barcelona: Actar Productions
22. Map of Western Europe from World Atlas, Rand: 1990.
23. St. Lazare Station from Duthilleul, J. (1998) *Agence des Gares AREP: Parcours 1988-1998*. Rome: Diagonale.
24. Section of St. Lazare Station from Duthilleul, J. (1998) *Agence des Gares AREP: Parcours 1988-1998*. Rome: Diagonale.
25. Plan of Euralille Station from Aben, R. (1999) *The Enclosed Garden: History and Development of the Hortus Conclusus and its Reintroduction into the Present-day Urban Landscape*. Rotterdam: 010 Publishers.
26. Abando Station



27. Stade de France from Duthilleul, J. (1998) *Agence des Gares AREP: Parcours 1988-1998*. Rome: Diagonale.
28. Euralille Station from Aben, R. (1999) *The Enclosed Garden: History and Development of the Hortus Conclusus and its Reintroduction into the Present-day Urban Landscape*. Rotterdam: 010 Publishers.
29. Canary Wharf Station. Received in interview with Megan Yakeley, Foster and Partners Press pack 2002.
30. Section of Canary Wharf. Received in interview with Megan Yakeley, Foster and Partners Press pack 2002.
31. Stadelhofen Station from 1997 *Architectural Review*, May, v. 201
32. Westminster Station from 1996 *World Architecture*, Jul-Aug n 48.
33. Houston from Garreau, J. (1991). *Edge City*. New York: Doubleday.
34. Phoenix from Garreau, J. (1991). *Edge City*. New York: Doubleday.
35. Dallas from Garreau, J. (1991). *Edge City*. New York: Doubleday.
36. Detroit from Garreau, J. (1991). *Edge City*. New York: Doubleday.
37. San Francisco from Garreau, J. (1991). *Edge City*. New York: Doubleday.
38. Washington DC from Garreau, J. (1991). *Edge City*. New York: Doubleday.
39. Boston from Garreau, J. (1991). *Edge City*. New York: Doubleday.
40. Atlanta from Garreau, J. (1991). *Edge City*. New York: Doubleday.
41. Road map of Atlanta received at MARTA rail station, Atlanta, GA
42. Aerial map of Lenox from <http://www.teraserver.com>
43. Mall Landscape from (1995) "Atlanta: A Reading." Atlanta. Jordi Bernadó, Barcelona: Actar Productions
44. Residential Development from (1995) "Atlanta: A Reading." Atlanta. Jordi Bernadó, Barcelona: Actar

Produccions

45. Business District from (1995) "Atlanta: A Reading." Atlanta. Jordi Bernadó , Barcelona: Actar Produccions
46. Phipps Plaza from <http://www.itsmarta.com>
47. East end of Lenox Station from (1995) "Atlanta: A Reading." Atlanta. Jordi Bernadó , Barcelona: Actar Produccions
48. Map of Lenox bus routes received at MARTA rail station, Atlanta, GA
49. MARTA Metro Map received at MARTA rail station, Atlanta, GA
50. MARTA Bus Map received at MARTA rail station, Atlanta, GA
51. MARTA Road Map received at MARTA rail station, Atlanta, GA
52. Temple Street Parking Garage from <http://www.bluffton.edu/~sullivanm/rudol>
53. Metro Station from *Shaping Time Light and Movement, A modern Rail Station for Boston*. unpublished Master's Thesis by Juintow Lin, Massachusetts Institute of Technology

Transportation images on pp 2 and 116 from license free CD by Pacific Sun Inc.