

**A PROPOSED SYSTEM  
FOR AVIATION  
NOISE MEASUREMENT  
AND CONTROL**

**Robert W. Simpson  
Anthony P. Hays**

**R73-2**

**January 1973**

**MIT**

**FTL COPY, DON'T REMOVE  
33-412, MIT .... 02139**

**DEPARTMENT  
OF  
AERONAUTICS  
&  
ASTRONAUTICS**

**FLIGHT TRANSPORTATION  
LABORATORY  
Cambridge, Mass. 02139**

A PROPOSED SYSTEM FOR  
AVIATION NOISE MEASUREMENT AND CONTROL

R. W. Simpson

A. P. Hays

FTL REPORT R73-2  
January 1973

A PROPOSED SYSTEM FOR  
AVIATION NOISE MEASUREMENT AND CONTROL

FTL Report R 73-2  
January 1973

Abstract

This report reviews previous work on various measures for aviation noise, and proposes a completely new system for aviation noise measurement and control compatible with real time, operational noise monitoring hardware. This new system allows new methods of control and **regulation** to be introduced and is designed to cover problems arising from future CTOL, RTOL, STOL, and VTOL aviation systems operating from current airports as well as new urban sites. New measures are proposed for aircraft flyover noise, airport noise exposure, and community noise impact.

## TABLE OF CONTENTS

<u>Title</u>	<u>Page</u>
Table of Contents	i
Definition of Terms; Nomenclature	ii
1.0 Introduction	1
1.1 Purpose of Report	1
1.2 Noise Control Options	2
1.3 Classification of Aviation Noise Measures	4
1.4 Outline of Report	7
2.0 Measurement and Control of <u>Aircraft Flyover Noise Level</u>	8
2.1 Measurement of Time Invariant Noise Levels	8
2.2 Proposed Method of Measuring Time Invariant Noise Levels	15
2.3 Duration Correction for Flyover Noise Level	17
2.4 Proposed Method of Measuring Flyover Noise Level	22
2.5 Regulations for Controlling Flyover Noise	24
2.6 Proposed Regulations for Controlling Flyover Noise	33
3.0 Measurement and Control of <u>Airport Noise Exposure Level</u>	37
3.1 Measurement of Multiple Event Noise Level	37
3.2 Proposed Method of Measuring Airport Noise Exposure Level	43
3.3 Regulations for Controlling Airport Noise Levels	45
3.4 Proposed Regulations for Controlling Airport Noise Levels	47
4.0 Measurement of Total <u>Community Noise Impact</u>	49
4.1 Measurement of Community Noise Impact	49
4.2 Proposed Method of Measuring Community Noise Impact	54
5.0 Summary Review of Proposed System of Aviation Noise Measurements	58
6.0 References and Selected Bibliography	61

## DEFINITION OF TERMS; NOMENCLATURE

The following definitions are given here in order to have some precision in using the following words:

SOUND: pressure waves in the atmosphere which produce a response in the human ear.

NOISE: sounds that are subjectively displeasing to the listener under a given set of circumstances .

NOISE LEVEL: sounds are weighed by frequency to account for the response of the human ear, and compared on a decibel scale to a reference sound. The particular type of weighting used should always be stated.

ANNOYANCE: subjective reaction to noise. The method of quantification has not been universally accepted but a doubling of annoyance for every 10dB increase in noise level is frequently used.

NOISE EXPOSURE: the effect of several noises heard at a single point over a period of time.

NOISE IMPACT: measures the total effect of noise exposure on a community and should consider such factors as local background noise and population density.

NOMENCLATURE: an attempt has been made to follow modern practice and write all decibel levels in the form  $L_x$  where x is the the type of measurement (e.g., Perceived Noise Level is written  $L_{PN}$ ). Where additional clarification is required a superscript may be used, e.g., Noise Pollution Level using A-weighted sound level may be written  $L_{NP}^A$ . Several noise measures (such as Composite Noise Rating, Noise Exposure Forecast, and Noise and Number Index) should, strictly speaking, be expressed in this form also, since they are also decibel levels. However, their nomenclature is most commonly expressed as CNR, NEF, and NNI, and this is followed in this report.

## 1.0 INTRODUCTION

### 1.1 Purpose of Report

The initial goal of this research was to suggest new measures for controlling the noise from future VTOL and STOL aircraft. In view of substantial differences in the time histories of flyover noise for takeoffs and landings, in view of proposals for future operations into built up city center areas and in view of forecast noise levels for rotary wing vehicles which are close to urban background noise levels, it was felt that the existing CTOL measures were not equitable for V/STOL aircraft. During the course of this work, however, it became apparent that there was a lack of coherence in the present methods for measuring aircraft and airport noise as they had developed over the past decade. Thus, rather than proposing a new and different methodology for VTOL and STOL aircraft, it was decided to propose a complete new system for measuring aviation noise.

This unified structure would be appropriate to current and future problems in noise control, and consistent for CTOL, STOL, and VTOL aircraft operations. It was decided that the structure had to be compatible with the implementation of real time, airport noise monitoring systems now being introduced at major airports around the world. This meant abandoning the "perceived noise" concept, but it was felt that these concepts had clearly been shown to be unnecessary anyway. A return to simpler measurement scales provided substantial benefits in terms of operational and regulatory flexibility.

The purpose of this report then became to propose a new global structure for measuring the noise from aircraft and airports appropriate for the present and future problems of noise control in aviation.

## 1.2 Noise Control Options

All systems for measuring noise are developed with an ultimate purpose of controlling the noise in some manner. The system of this report allows a wide variety of noise control options to be available. However, it is not the purpose of this report to advocate the use of any of these options, or to establish allowable noise levels within an option, or to suggest any particular noise control agency. These are questions to be resolved by political processes.

The options in noise control are briefly outlined by identifying the following elements.

### 1.2.1 Noise Control Agency

The agencies responsible for carrying out noise control may be classified as operator, local, and federal. The airport operator as landlord has the right to impose conditions upon users of his facility to protect himself from lawsuit. In the U.S.A., local government agencies may impose conditions on noise levels from activities occurring in their area, in the absence of pre-emption by federal agencies acting in the name of interstate commerce or environmental protection. At present, all three of these agencies may be trying to control the noise at an airport (e.g. Los Angeles). While political and legal processes will eventually determine the relationship between these agencies for controlling noise, it is desirable that they all adopt and use a common system for noise measurement.

### 1.2.2 Methods of Controlling Noise

The controls used by these agencies may be classified into the following three methods.

#### 1.2.2.1 Control of Noise Generation

This method suppresses the noise generated at the source by requiring the manufacturer to meet standards for new aircraft, or supply retrofit items to quiet aircraft produced earlier



#### 1.2.2.2 Control of Noise Exposure

This method controls the number and kind of aircraft activities at a given airport. It produces quotas and curfews on the number of operations over some period of time, and specifies operational procedures and flight paths to minimize the exposure of the listeners to the noise source.

#### 1.2.2.3 Control of Noise Impact

This method controls the noise received by listeners by zoning the land around the airport to prevent an influx of listeners, by acquiring land and removing listeners, by soundproofing buildings, or by supplying compensation for noise.

#### 1.2.3 Noise Sanctions

Noise control methods have two main options in their execution. They may act by fiat, either by specifying a limit which must never be exceeded, or by specifying a limit which if exceeded results in economic penalties. This is the only option exercised to date, and it only controls the upper bound or extreme which noise levels may reach.

However, another major option in executing noise control is to apply economic sanctions on all noise generated above a given level of quietness. This "dollar per decibel" approach applies pressures on all noise generated, and controls the average level of noise, rather than the extreme values.

### 1.3 Classification Scheme for Aviation Noise Measures

We shall classify noise measures used in aviation into three distinct categories:

- 1) those used to measure noise from the single flyover of an aircraft.
- 2) those used to measure noise exposure over time from a set of aircraft activities at a point adjacent to an airport.
- 3) those used to measure noise impact over time and over the area of the communities around the airport.

The proposed measures are based upon this classification scheme. The reader should especially note that the words "exposure" and "impact" are used in a very precise manner. We shall now discuss current measures in terms of their classification.

#### 1.3.1 Aircraft Flyover Noise Level Measures

Existing measures such as  $L_{EPN}$ , or  $L_{SENE}$  (California) are designed to measure the maximum intensity level of the noise made by a single aircraft overflight. They are measures of the noise generated by a noise source, where that source is the aircraft.

Effective Perceived Noise Level,  $L_{EPN}$ , is currently used as part of U.S. regulations which specify noise limits for jet subsonic transport aircraft as part of the certification of those aircraft for public use. The limits apply to precisely specified flight trajectories, under standard weather conditions, and with the aircraft at certificated full operating gross weights. The method of measurement requires detailed computations based on field measurements, and the results are usually not available until days after the tests.

The noise levels under these specific conditions are only rarely duplicated in **actual** service. Due to lesser gross weights, wind and atmospheric conditions, and non-standard speeds and flight trajectories, the operational noise levels vary quite widely from the standard cases.

If it is desired to impose a limit on operational noise levels, or if a noise tax (dollar per decibel) scheme is to be instituted, it becomes necessary to use a measurement of aircraft flyover noise level which can be recorded in real time. The creation of this measurement and its control schemes argues for changing the present certification measurement to conform closer to operational procedures.

### 1.3.2 Airport Noise Exposure Measures

Proposed measures such as CNR, NEF, and existing measures such as NNI and  $L_{CNE}$  (California) record the noise exposure over some period of time from multiple aircraft operations at a single point in the community surrounding the airport. Here we shall use the term "exposure" for such measures and restrict the general usage of that term. The locus of points of equal exposure is a "noise exposure level contour" which may be mapped around a system of runways given the operational history over some period of time.

Due to the differences between operational and certificated noise levels, it is important that the actual operational noise exposure levels be measured by "airport noise monitoring systems". This **will** require real time field measurements to produce hourly levels of noise exposure. Future **measures** adopted should be consistent with the real time measurement of flyover noise.

The community noise monitors may be used to control the frequency or type of operations at a given airport to keep noise exposure below hourly, daily, or annual limits. If a compensation scheme is instituted, payments or property tax credits would be based on the actual exposure recorded in the community.

### 1.3.3 Community Noise Impact Measures

Where as noise exposure measures cumulated noises over some time period, noise impact measures are defined to accumulate over both time and area.

In this class are proposed measures such as "footprint area" for some NEF contour, ASDS footprints measured in "acre-minutes", TCAM (Total Community Annoyance Measure, see sec. 4.1.2), and W (Community Sensitivity Weighting, see section 4.1.3).

These "impact" measures are not as widely developed as the measures in the previous two categories, but are vitally necessary in various planning activities. They would be used to plan preferential runway operations on a daily basis, to assist in siting new runways or airports, to measure the benefits from new aircraft operating procedures, or to measure the benefits from changes to existing aircraft such as engine or nacelle retrofit. Notice that none of the measures of the previous two categories are useful in answering these planning issues. It is desirable that future measures of impact be consistent with the measures used for aircraft flyover and airport exposure noise.

#### 1.4 Outline of Report

The report is structured into three major parts corresponding to Aircraft Flyover Noise, Airport Noise Exposure, and Community Noise Impact. In each part, measures of noise developed in the past are described, and a new measure is then proposed. In the parts on Aircraft and Airport Noise, present noise control regulations are described, and new methods of regulation are proposed.

A summary review of the proposed System of Aviation Noise Measurements is given at the end of the report.

## 2.0 MEASUREMENT AND CONTROL OF AIRCRAFT FLYOVER NOISE LEVEL

### 2.1 Measurement of Time Invariant Noise Levels

Objective noise measures, such as Overall Sound Pressure Level, are of little use when trying to measure the loudness of a sound. The ear is most sensitive to sounds in the frequency range of speech (1,000 - 5,000 Hz) so that two sounds with the same overall sound pressure level but different distributions of intensity across the frequency spectrum may appear to be of different loudness. Single event noise measures may be divided into two classes:

- 1) measures that relate to an instantaneous or time invariant level of sound,
- 2) measures that relate to the duration, or time variation of the sound.

In the former category are A-weighted sound level and Perceived Noise Level and in the latter category are Effective Perceived Noise Level, and Single Event Noise Equivalent Level (California Noise Regulations).

Definitions of other noise levels that are not directly applicable to aircraft noise, such as Loudness Level, Articulation Index and Speech Interference Level, may be found in Reference 1.

#### 2.1.1 A-Weighted Sound Level

The earliest measure formulated is the A-weighted sound level ( $L_A$ ). It is important because it is easy to use, has been universally accepted as a standard, and relates reasonably well to judged assessment of the annoyance of noise. Sounds are frequency weighted, and the weighting is based on the apparent loudness of a sound relative to a tone of 1000 Hz. The distribution of the weighting is shown in Figure 2.1; the Sound Pressure Level at any frequency is multiplied by

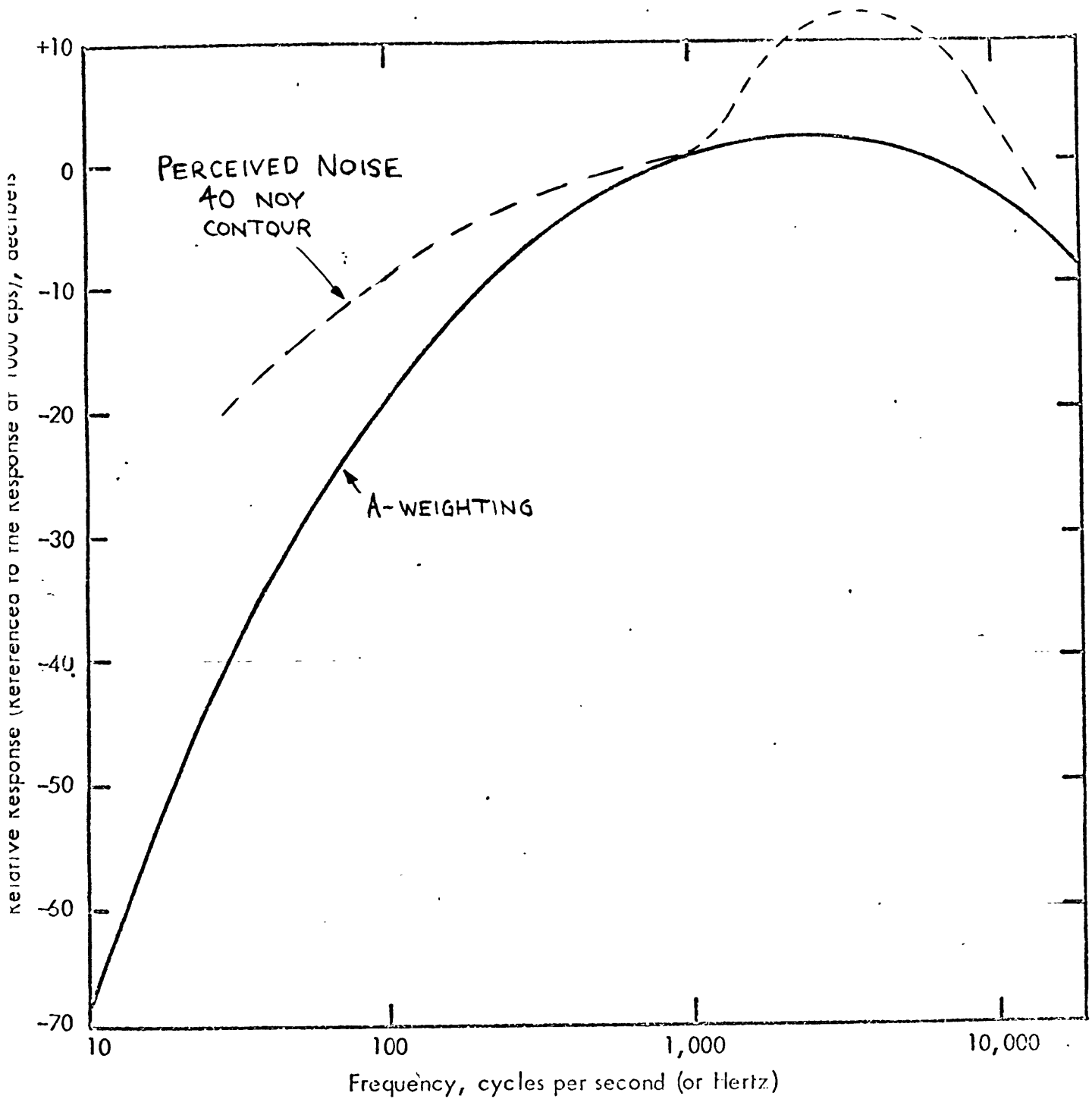

Figure 2.1-A COMPARISON OF A-WEIGHTING AND PERCEIVED NOISE  
WEIGHTING (from Ref. 2)

the weighting corresponding to that frequency, and the overall sound level is found in a manner analogous to finding the Overall Sound Pressure Level. This weighting may be done by a simple electrical weighting network, so that the sound level may be displayed directly on a meter.

### 2.1.2 D-Weighted Sound Level

The D-weighted Sound Level (also called N-weighted Sound Level) is similar to A-weighted Sound Level, that is, frequency weighting and summation on an "energy" basis. The only difference is in the shape of the frequency weighting curve, which for D-weighting corresponds to the "40-noy" contour (see Figure 2.1) which is used in the calculation of  $L_{PN}$ . D-weighted Sound Level appears to correlate slightly better than A-weighted Sound Level with judged noisiness, but because of its later introduction it has not gained as wide a recognition as  $L_A$ .

### 2.1.3 Perceived Noise Level

When jet transports came into service it was thought that the A-weighting network underestimated the annoyance of jet noise as compared with propeller driven aircraft. A new weighting formulation was developed based on "noisiness" and "unacceptability" rather than "loudness" - this measure is known as Perceived Noise Level (designated  $L_{PN}$ ). Two important differences between A-weighted sound level and Perceived Noise Level are: 1) different weighting is given to sound (see Figure 2.1). The weighting at a given frequency also depends on the Sound Pressure Level at that frequency. 2) The calculation takes account of the "masking" effect of the most prominent part of the noise spectrum; that is the noisiness in "noys" of 1/3 octave bank levels, apart from the loudest, are reduced.



Lp  
dB

One-Third Octave Band Center Frequencies f, HZ

30 63 80 100 125 160 200 250 315 400 500 630 800 1000 1250 1600 2000 2500 3150 4000 5000 6300 8000 10000

Table 2.1 NOYs As a Function of Sound Pressure Level.

(from Ref. 2)

Table with 24 columns (frequencies) and 24 rows (NOYs). Values range from 1.00 to 16.00, showing a logarithmic relationship between frequency and NOY.

N.S.T.E. 22 NOV 1967

The instantaneous Perceived Noise Level is calculated according to the following three step procedure taken from Reference 2.

Step 1

Convert each measured 1/3 octave band sound pressure level in the range 50 to 10,000 Hz,  $L_p(i)$ , that occur at any given instant of time, to perceived noisiness (Noys),  $n(i)$ , by reference to Table 2-1.

Step 2

The Noy values,  $n(i)$ , found in step 1, are combined in the manner prescribed by the following formula:

$$N = \underline{n} + 0.15 \left[ \sum_{i=1}^{24} n(i) - \underline{n} \right] \quad (2.1)$$

where  $\underline{n}$  is the number of Noys in the noisiest band and N is the total Noy value.

Step 3

The total perceived noisiness, N, is converted into Perceived Noise Level,  $L_{PN}$ , by means of the following formula:

$$L_{PN} = 40 + 33.3 \log N \quad (2.2)$$

which is plotted in Figure 2.2  $L_{PN}$  can also be obtained by choosing N in the 1000 Hz column of Table 2.1 and reading the corresponding value of  $L_p$  which, at 1000Hz, is identically equal to  $L_{PN}$ .

The maximum value of the instantaneous  $L_{PN}$  is designated  $L_{PN_{max}}$ . For the case of an aircraft flyover a slightly different formulation is Peak Perceived Noise Level ( $L_{PN_{peak}}$ ), in which case the 1/3 octave band levels are to be the peak values attained in each band during the event, regardless of when these peaks occur.  $L_{PN_{peak}}$  is not an instantaneous value and

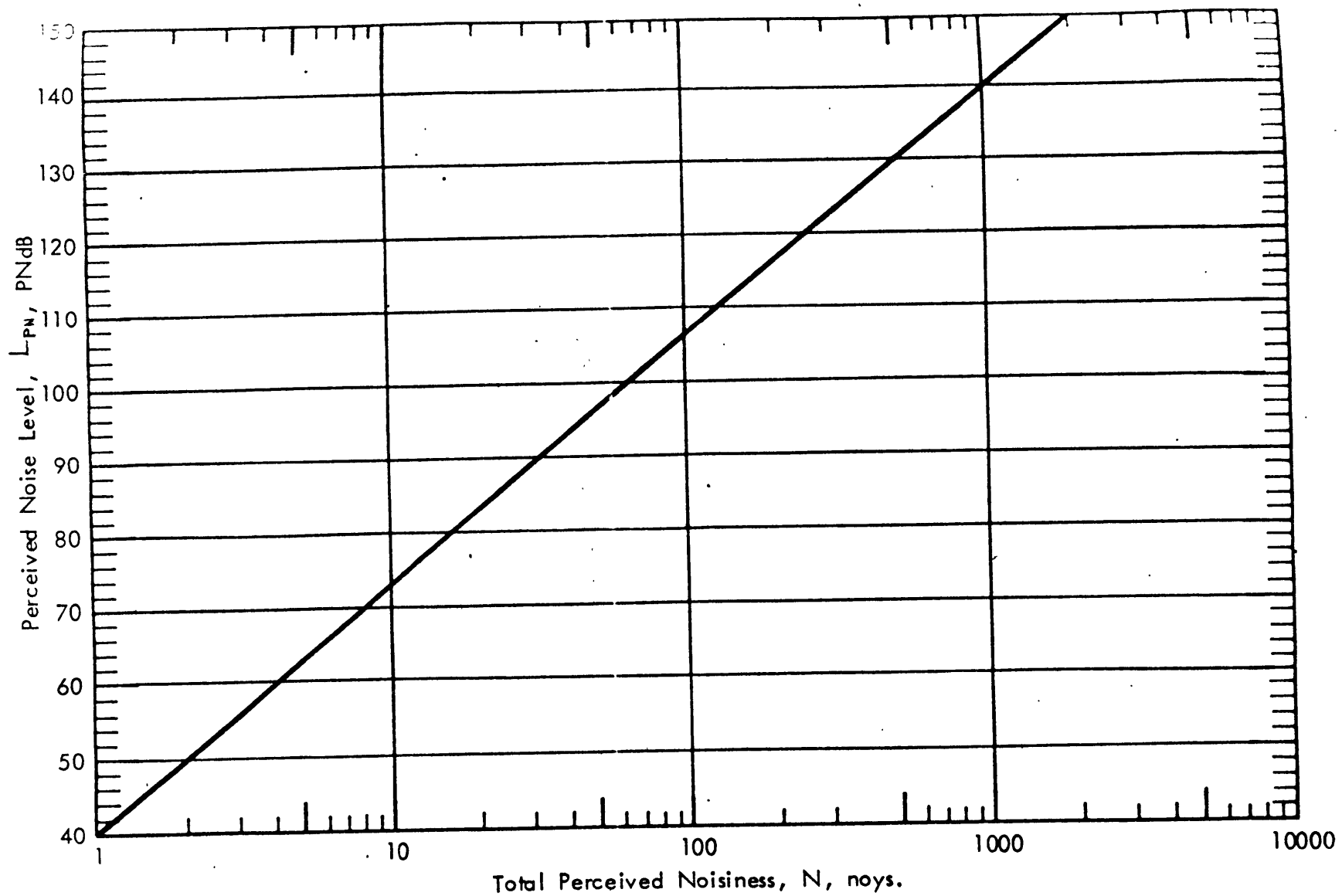

Figure 2.2 PERCEIVED NOISE LEVEL AS A FUNCTION OF NOYS (from Ref. 2)

cannot be used to calculate  $L_{PN_{max}}$ .

A correction may be made for the effect of pure tones in the spectrum, which may well occur for fan engine noise. This correction is fairly complex, but is given on page 23 of Reference 2. Tone-corrected Perceived Noise Level is designated  $L_{TPN}$ .

Approximate relationships between  $L_{PN}$  and  $L_A$  and  $L_D$  are:

$$L_{PN} = L_A + 13 \quad (2.3)$$

$$L_{PN} = L_D + 6 \quad (2.4)$$

$$L_D = L_A + 7 \quad (2.5)$$

## 2.2 Proposed Method of Measurement of Time Invariant Sounds

Several experiments have been performed in order to evaluate the effectiveness of the measures just described. A report by Serendipity Inc. (Ref. 1) has surveyed some of these experiments, notably those by Ollerhead (Ref. 3), Williams et al, Hecker & Kryter and Young and Peterson. Specific conclusions cannot be summarized without detailing the conditions under which the experiments were performed, but they generally indicate that for sounds of constant duration there is little to choose between A-weighted or D-weighted Sound Level ( $L_A$  or  $L_D$ ) or Perceived Noise Level ( $L_{PN}$ ) as methods of measuring aircraft noise. The argument is made that there is no virtue in trying to determine, to a high degree of accuracy, a subjective reaction that is not determinate. A later report by Ollerhead (Ref. 4) concludes that "despite deficiencies that cannot be overcome by refined weighting circuits, it is clear that the weighted sound pressure level provides a very powerful scale for comparing the sounds of aircraft". In Reference 5, Kryter recommends the use of  $L_D$  over  $L_A$  since it weighs low frequency sound more heavily.

$L_A$  or  $L_D$  may be measured using a hand held sound level meter, whereas  $L_{PN}$  involves a simple, but tedious, calculation involving analysis of octave band levels; a computer is required for repeated measurements. A small single purpose computer could be built, but as far as is known an " $L_{PN}$  meter" does not exist on the market. For compatibility with the introduction of airport noise monitoring systems, the D-weighted sound level is recommended over Perceived Noise Level as the unit for measuring aircraft noise.

It may be argued that to return to a noise measure that did not include the subjective effect of pure tones is a backward step. However, there is evidence to suggest that acoustic linings on the intake and exhaust of the engine are

particularly effective in eliminating pure tones because the lining can be tuned to absorb a certain frequency (Ref. 6). Thus there is still an incentive in eliminating pure tones from the acoustic signal of the engine because it will achieve some reduction in noise level in dB(D) (although not as great a reduction in noise level measured in EPNdB), at comparatively low cost. Furthermore, Ollerhead (Ref. 4) found only a marginal improvement in subjective reactions due to the application of the tone correction to the PNL procedure. The only major reservation concerning the use of D-weighted sound level is the fact that it fails to correlate as well with noisiness for low frequency sounds (e.g. helicopter sounds) as with high frequency sounds. This failing is common to all perceived noisiness scales (Ref. 4). Ollerhead suggests that further experimental research is required into the perception of low frequency harmonic noise. It is anticipated that a solution can be found to the problem of very low frequency helicopter noise (i.e. rotational noise and blade slap) through design modifications.

## 2.3 Duration Correction For Flyover Noise Level

### 2.3.1 Effective Perceived Noise Level

In order to account for the duration effect of an aircraft flyover a refinement has been introduced which utilizes the fact that annoyance appears to increase in a manner related to the total energy of the sound received; doubling the duration of a noise is considered equivalent to increasing the level of the noise by 3dB.

Tone-corrected Perceived Noise Level is therefore converted into a form that approximates to its intensity and then summed, finally being reconverted back into a decibel form.

The expression for  $L_{EPN}$  may be written:

$$L_{EPN} = 10 \log \left[ \frac{1}{T} \sum_{k=0}^{d/\Delta t} 10^{L_{TPN}(k)/10} \Delta t \right] \quad (2.6)$$

where T is a normalizing time constant.

$L_{TPN}(k)$  is the value of  $L_{TPN}$  at the k-th increment of time.

d is the duration of the time interval during which  $L_{TPN}$  is within a specified value, h, of  $L_{TPN_{max}}$ .

These are illustrated in Figure 2.3.

The following figures are most commonly used when calculating  $L_{EPN}$ :

$$T = 10 \text{ sec.}$$

$$t = 0.5 \text{ sec.}$$

$$h = 10 \text{ dB}$$

Equation 2.6 then becomes:

$$L_{EPN} = 10 \log \left[ \sum_{k=0}^{2d} 10^{L_{TPN}(k)/10} \right] - 13 \quad (2.7)$$

Figure 2.3  $L_{EPN}$  CALCULATION METHOD

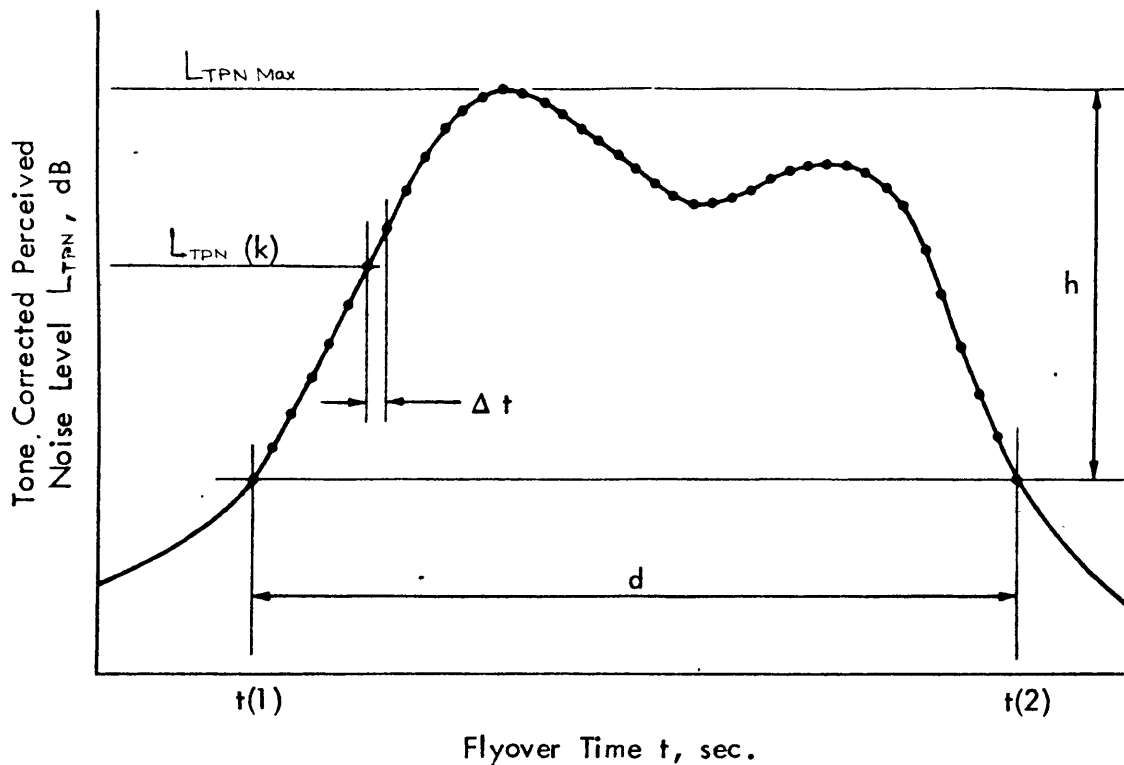
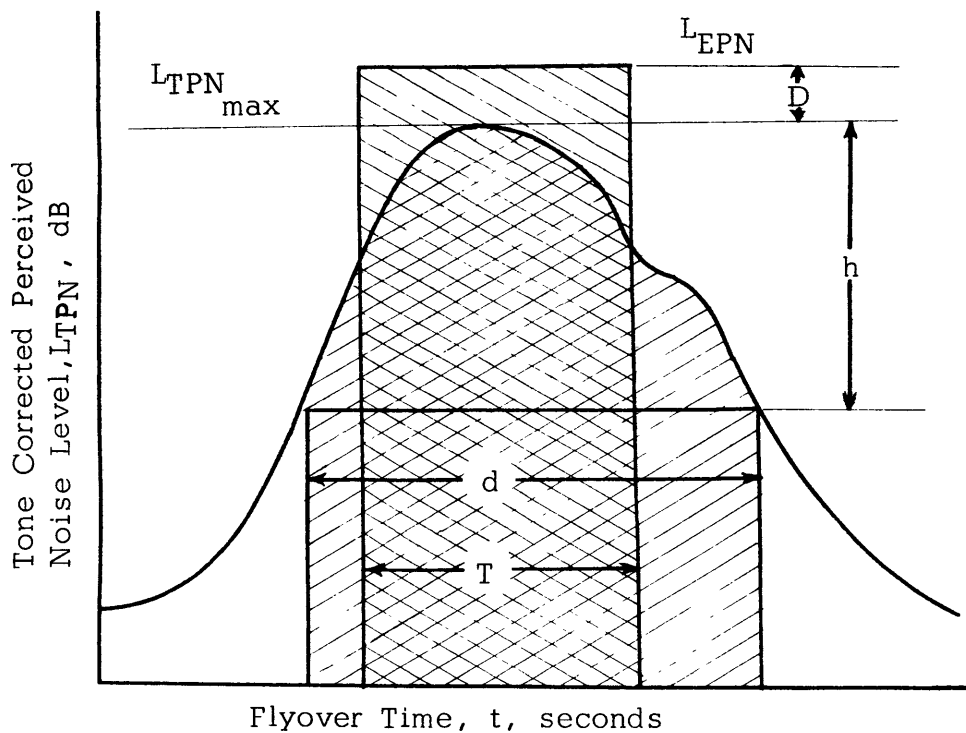

Figure 2.4  $L_{TPN}$  to  $L_{EPN}$  CORRECTION METHOD





The "10dB-down" cut off points serve mainly to avoid the inclusion of a part of the history of the noise that does not significantly affect the result; a value of  $L_{TPN}$  that is 10dB below the maximum possesses an order of magnitude lower value of intensity, and is therefore not significant.

Equation 2.6 may be rewritten in the form:

$$L_{EPN} = L_{TPN_{max}} + 10 \log \left[ \int_{t_0}^{t_1} 10^{L_{TPN}/10} dt / 10^{L_{TPN_{max}}/10} \cdot T \right] \quad (2.8)$$

where  $t_0$ ,  $t_1$  correspond to the "10dB-down" points. In this form of the equation it can be seen that the total weighted energy is divided by the energy received from a sound that has a square noise distribution with time (see Fig. 2.4). If the energy received is less than the reference energy, then a correction is subtracted from  $L_{TPN_{max}}$ ; if greater, the correction is added.

Reference 2 suggests that an approximate method of determining this correction is by means of the formula:

$$D = 10 \log \left( \frac{d}{t} \right) \quad (2.9)$$

Where  $D$  = the correction to be added or subtracted from the value of  $L_{TPN_{max}}$ .

$d$  = the time interval during which  $L_{TPN}$  is within a specified value,  $h$ , of  $L_{TPN_{max}}$ .

$T$  = a normalizing constant.

The following values are suggested.

$T$  = 15 sec.

$h$  = 10 dB.

Equation 1.9 becomes:

$$D = 10 \log \left( \frac{d}{15} \right) \quad (2.10)$$

This method yields, in general, corrections that are larger than the exact method.

### 2.3.2 California Noise Regulations: Single Event Exposure Level

The State of California has introduced noise measures with which to control the levels of noise around airports in California. Details of the multiple event noise measures will be given in Part 3; the single event noise measure within these regulations is included here.

The Single Event Noise Exposure Level ( $L_{SENE}$ ) is in some ways similar to Effective Perceived Noise Level. The antilogarithm of the A-weighted sound pressure level is integrated over time and then converted into a decibel form, the reference duration for time being one second. From Reference 7, appendix D,  $L_{SENE}$  may be defined as:

$$L_{SENE} = L_{A_{max}} + 10 \log \left[ \frac{\int_{t_0}^{t_1} 10^{L_A/10} dt}{10^{L_{A_{max}} t_{ref}}} \right] \quad (2.11)$$

Where  $L_{A_{max}}$  = the maximum A-weighted sound level.

$L_A$  = the instantaneous value of A-weighted sound level.

$t_{ref}$  = a reference time of 1 second.

$t_0, t_1$  = the times at which the sound level is within at least 30 dB of the maximum allowable level of  $L_{SENE}$

In the form of equation 2.11 the duration correction term compares the A-weighted sound pressure energy to the A-weighted energy contained in a pulse of sound with duration of 1 second and constant level of  $L_{A_{max}}$ . The ratio of the energies is converted into a decibel form.

Alternatively equation 2.11 may be written in the form:

$$L_{SENE} = 10 \log \left[ \frac{1}{t_{ref}} \sum_{k=0}^{d/\Delta t} 10^{L_A(k)/10} \Delta t \right] \quad (2.12)$$

Where  $L_A(k)$  = the value of  $L_A$  at the k-th increment of time.

$d$  = the duration of the time interval during which  $L_A$  is within at least 30 db of the maximum allowable value of  $L_{SENE}$ .

The formulation also shows the similarity between  $L_{SENE}$  and  $L_{EPN}$ . (See 2.6) A rough relationship between  $L_{SENE}$  and  $L_{EPN}$  is given by:

$$L_{SENE} \approx L_{EPN} - 6 \quad (2.13)$$

The apparent flexibility in the cutoff times does not significantly affect the result of the calculation unless the peak value of  $L_A$  is only a few dB(A) above the cutoff value. Most of the energy of the flyover noise is close to the peak; sounds more than 10dB down from the peak contain less than 10% of the energy at the peak. The important consideration is that the cutoff value should be above the ambient noise level; if this is not so the cutoff must be adjusted upwards to be above the ambient level. While this is not a problem for noise from current aircraft, it will be in future years, and requires changing the definitions for  $L_{SENE}$  and  $L_{EPN}$ .

## 2.4 Proposed Method of Measuring Flyover Noise Level

The most commonly used noise measure for aircraft noise,  $L_{EPN}$ , and the California Noise Measure  $L_{SENE}$ , both assume that there is a 3dB increase in subjective noise for every doubling of duration. Little and Mabry (Ref. 7) show a 0.6 to 3.1 dB per doubling of duration for sounds of 1-34 seconds in duration with a mean of 2.0 dB per doubling. Earlier work by Kryter & Pearson (Ref. 8) had shown that doubling the duration of a test sound had to be counter-balanced by reducing its level by 4.5 dB in order to maintain the same impression of disturbance, although subsequent extension of these experiments showed from 6 to 2 dB per double duration.

In view of this apparent mixture of results, it should be noted that the 6 dB increase in noisiness per doubling of duration applied to sounds of less than 5 seconds in duration; for sounds of 5 to 50 seconds in duration, a 3 dB increase in noisiness per doubling of duration is a reasonably close approximation to the empirical data. This is concurred in by Ollerhead (Ref. 4) who found that 3 dB per duration doubling was close to optimum for aircraft sounds.

The evidence therefore points to the conclusion that duration correction of 3 dB per double duration is generally reasonable. We shall propose the adoption of an aircraft noise measure similar to the measure proposed by the California regulations except that we shall use the D-weighted noise scale.

### 2.4.1 Aircraft Effective Noise Level, $L_{DE}$

We define an effective noise level measure using the D-weighted scale:

$$L_{DE} = 10 \log \left[ \frac{1}{t_{ref}} \sum_{k=0}^{d/\Delta t} 10^{L_D(k)/10} \cdot \Delta t \right]$$

$t$  = integration interval,  $k = k^{th}$  interval.

$t_{ref}$  = reference time = 1 second

$d$  = duration of sound above some nominal background level such as  $L_D = 80$ .

This is similar to the definition of  $L_{SENE}$  except for the use of a D weighted noise scale, and definition of  $d$  as time above a nominal level. Thus, the monitor microphones are set at a given "breakout" level.

This measure can be used to certify new transport aircraft instead of  $L_{EPN}$ , and it also allows construction of field measurement equipment that can be used in real time. Certification limits can be established for the values at three basic measuring points, and "runway monitor" instrumentation constructed at similar points relative to real airport runways to measure operational flyover noises.

## 2.5 Regulations for Controlling Aircraft Flyover Noise

### 2.5.1 Port of New York Authority Regulations

The first regulations controlling the level of flyover noise from jet transport aircraft were established by the Port of New York Authority in its role as landlord. These rules are still in effect, and are applied through the use of noise monitoring equipment at J.F.K. Airport. Microphones are placed on the extended runway centerline at the approximate boundary of the community (varying between 2.8 and 7 miles from the start of roll depending on runway). A maximum noise level of 112 PNdB is allowable, above which an infringement is recorded in the name of the offender. Infringement reports are made to each airline monthly, and repeated violations bring threat of legal suit. Although measuring aircraft flyover noise levels, this process is a means towards minimizing extreme levels of community noise exposure, and the resulting complaints or lawsuits from the community due to this exposure.

### 2.5.2 Jet Subsonic Transport Aircraft (FAR Part 36)

The calculations for  $L_{EPN}$  are somewhat unwieldy, and a computer is generally required to calculate the value of  $L_{EPN}$  from a knowledge of the noise spectrum and its time history. However, this criterion is important because it is utilized presently in the Federal Aviation Regulations (Ref. 11) which limits the allowable noise of jet subsonic transport aircraft which are certified after 1 December 1971. These regulations limit the certificated values of  $L_{EPN}$  as measured at three points as shown in figure 2.5. The reference point for landing approach is 1 n. mile from threshold; the reference point for takeoff is 3.5 n. miles from start of takeoff roll; the reference point for sideline noise during roll is located 0.35 n. miles to the side of the runway for 4 engine jets, and 0.25 n. miles otherwise.

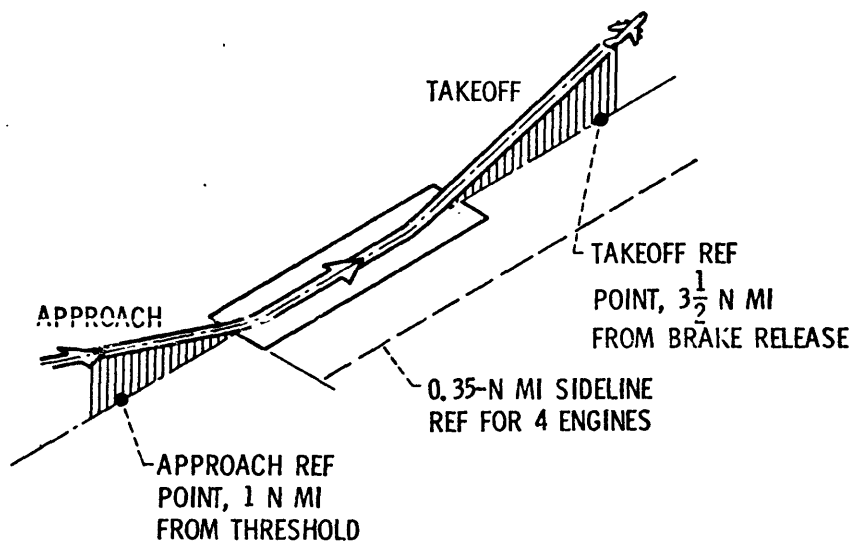

FIG. 2-5 FAA CTOL NOISE REFERENCE LOCATIONS

# APPROACH NOISE LEVELS

(1n.mil. from threshold on the extended runway centreline)

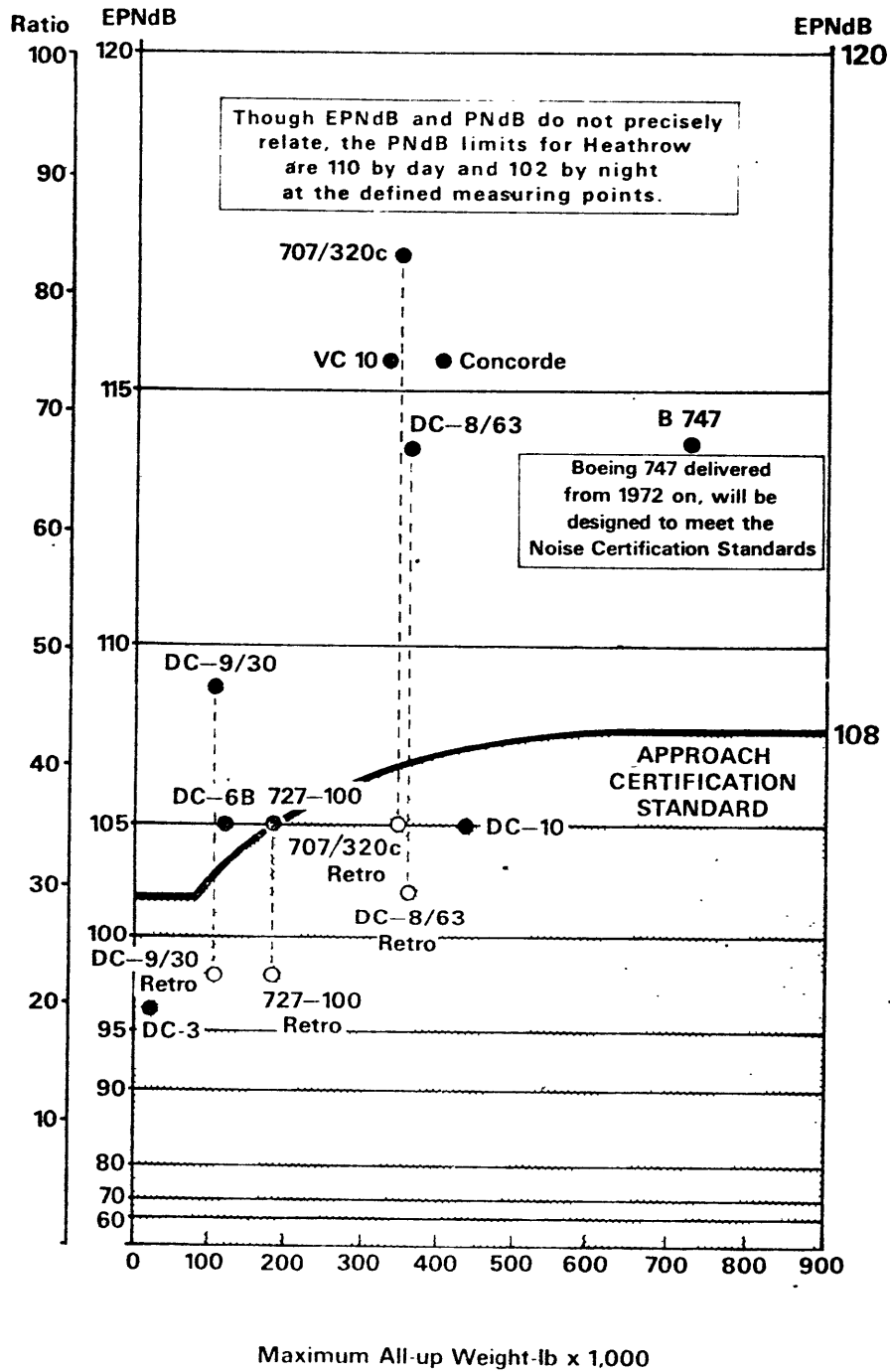

Figure 2.6 F.A.R. PART 36 APPROACH NOISE LEVELS (from Ref. 18)



# TAKE-OFF NOISE LEVELS

(3.5 n.m.l. from start of roll on extended runway centre line)

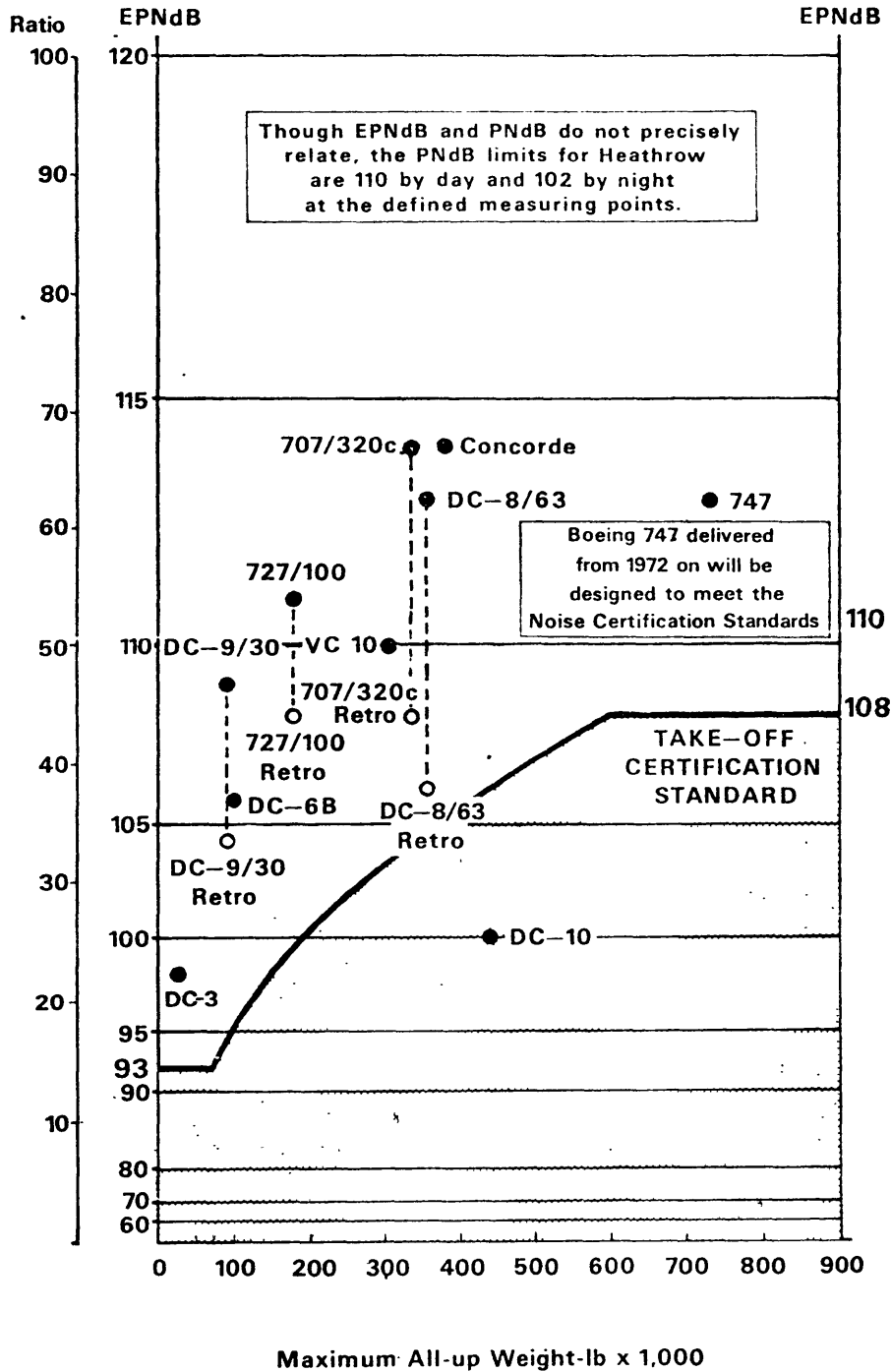

Figure 2.7 F.A.R. PART 36 TAKE-OFF NOISE LEVELS (from Ref. 18)

# SIDE-LINE NOISE LEVELS

At a point on a line parallel to runway centre line  
 3 engines and less 0.25n.ml.  
 more than 3 engines 0.35n.ml.

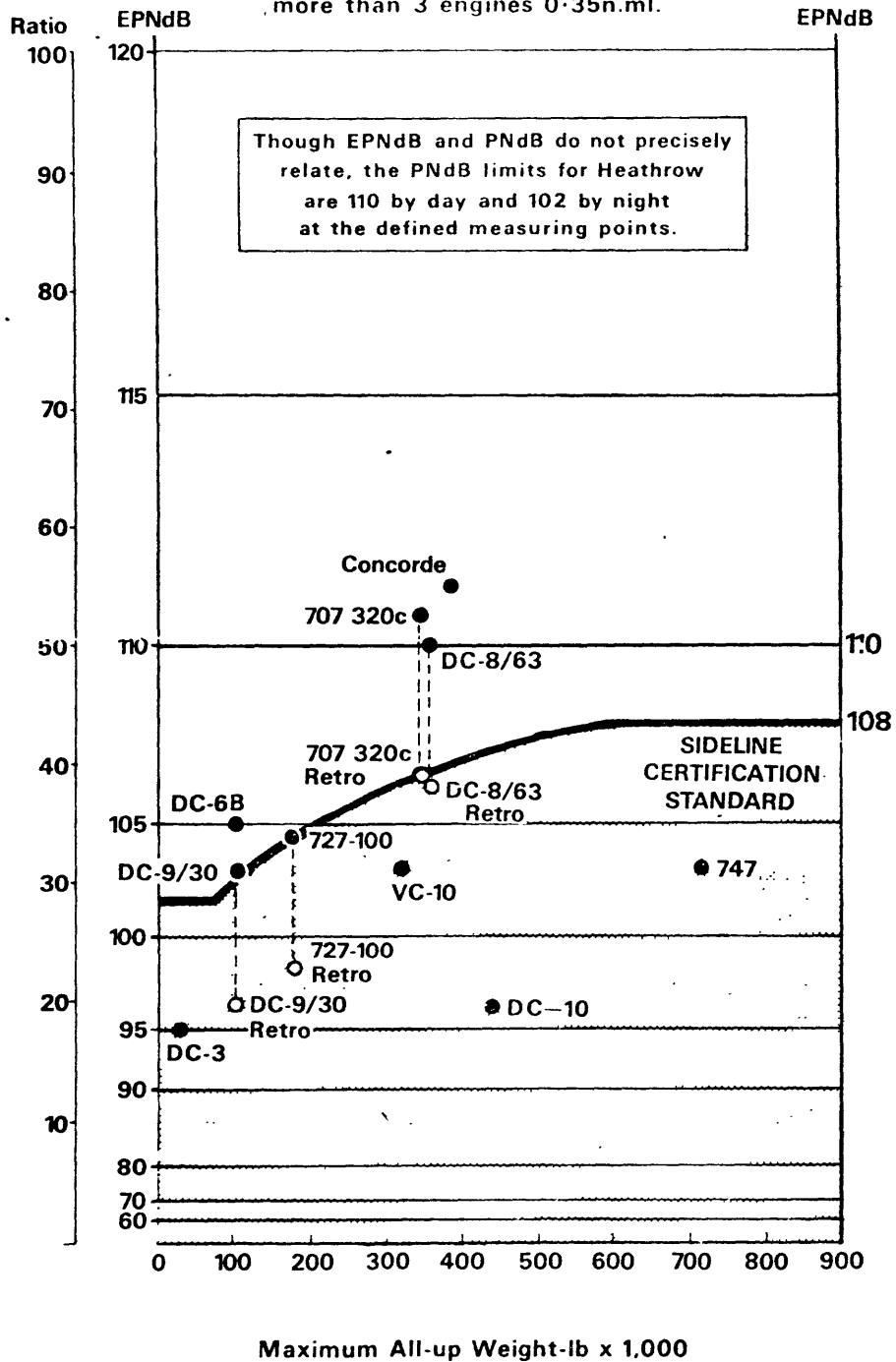

Figure 2.8 F.A.R. PART 36 SIDE-LINE NOISE LEVELS (from Ref. 18)

The levels of current aircraft are compared to the limits of FAR (Part 36) in figures 2.6, 2.7, and 2.8.

Exceptions to the regulations are aircraft that were in a late state of development at the time the regulations were adopted (such as the B-747, although Boeing agreed to meet the requirements in 747s delivered after 1 December 1971) supersonic transport aircraft, and STOL or VTOL transports.

### 2.5.3 California Noise Regulations

The value of  $L_{\text{SENE}}$  specified by the California regulations (as of 11/28/70) is given in Figures 2.9, 2.10 and 2.11. Fig. 2.9 shows the range of positions for the measuring points for takeoffs and landings. Figure 2.10 shows the  $L_{\text{SENE}}$  limits for takeoff for varying classes of aircraft as a function of this position. Figure 2.11 shows the  $L_{\text{SENE}}$  limits for landing by various classes of aircraft as a function of the position of the landing microphone. Aircraft of a given class must not exceed these limits as recorded in actual operations by the microphones.

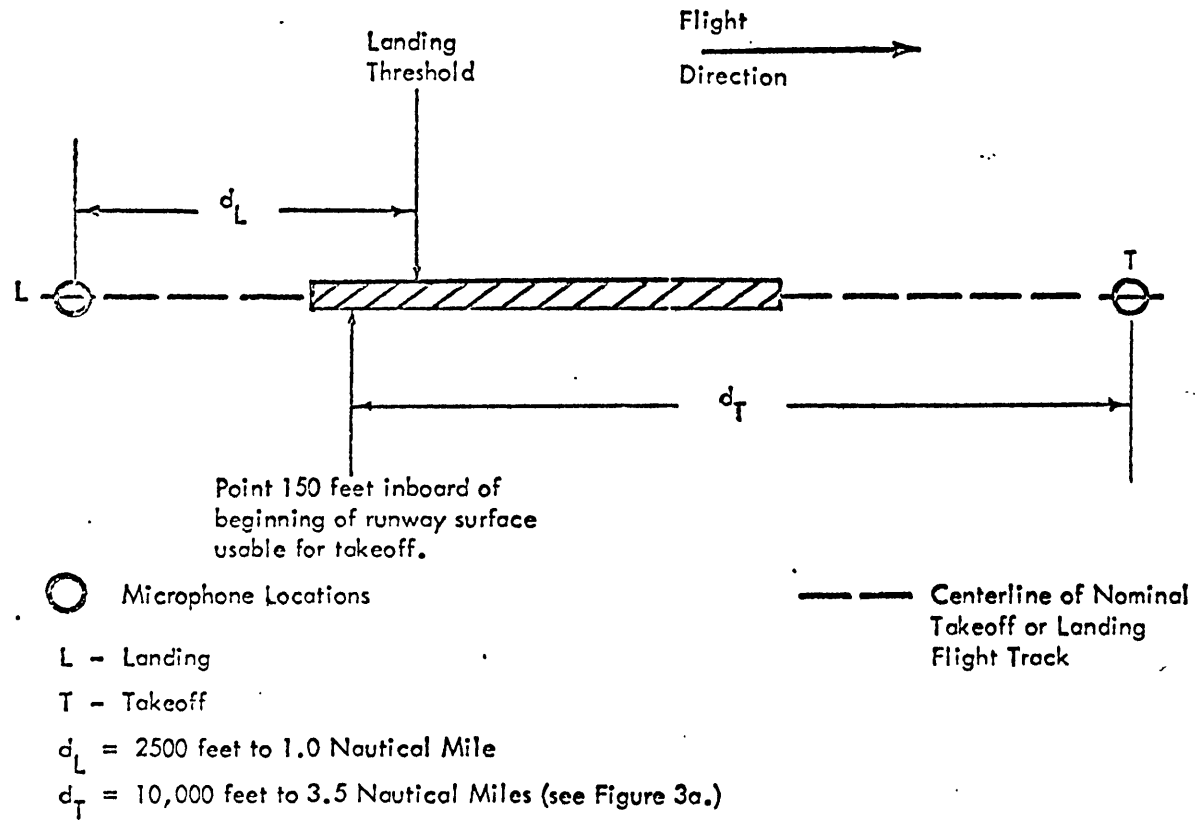

Figure 2.9 SINGLE EVENT NOISE EXPOSURE LEVEL MONITORING POSITIONS (from Ref. 9)

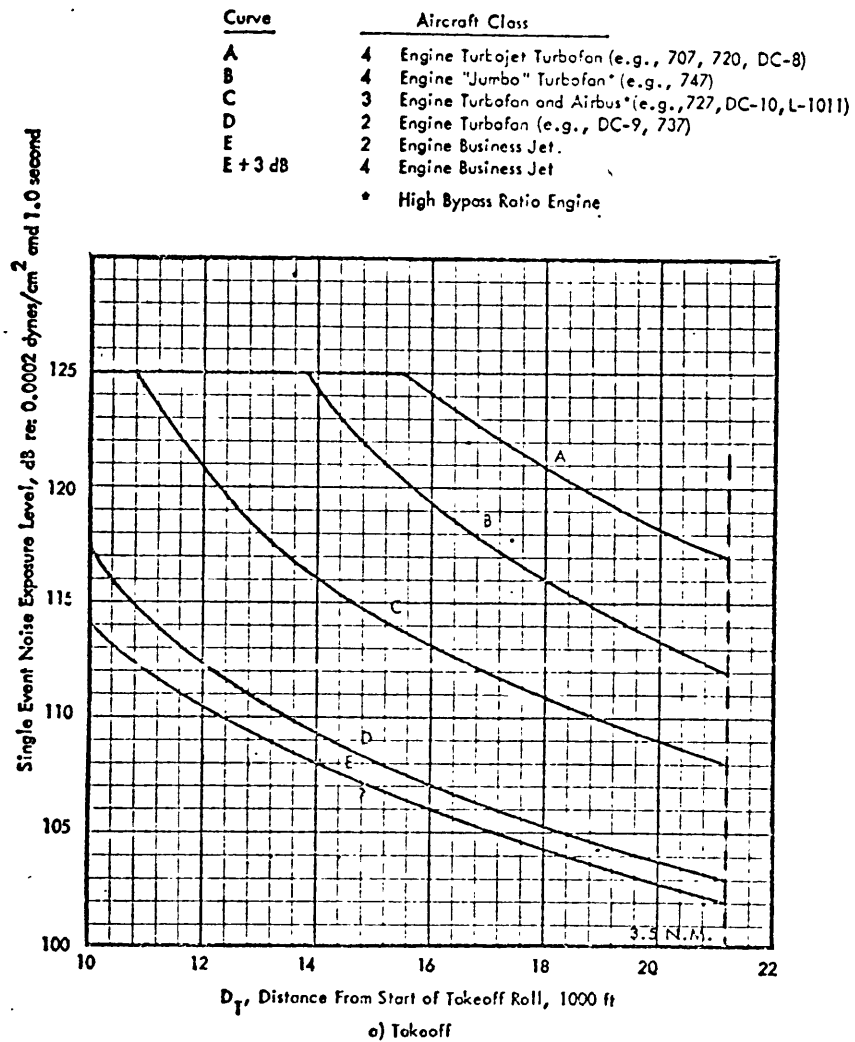

Figure 2.10 MAXIMUM LIMITS FOR SINGLE EVENT NOISE EXPOSURE LEVEL  
(from Ref. 9)

Curve	Aircraft Class
Z	4 Engine Turbojet and Turbofan (e.g., 707, 720, DC-8)
Y	2,3 Engine Turbofan (e.g., 727, 737, DC-9)
X	4 Engine "Jumbo" Turbofan* (e.g., 747)
W	3 Engine Airbus Turbofan* (e.g., DC-10, L-1011)
V	2 Engine Business Jet
V+3 dB	4 Engine Business Jet

\* High Bypass Ratio Engine

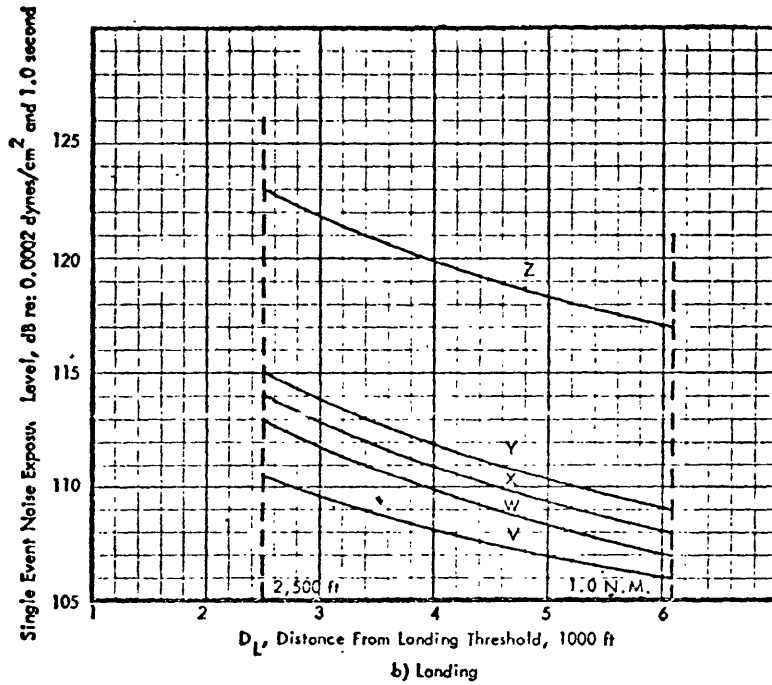

Figure 2.11 MAXIMUM LIMITS FOR SINGLE EVENT NOISE EXPOSURE LEVEL  
(from Ref. 9)

## 2.6 Proposed Regulations for Controlling Aircraft Flyover Noise

In this section, we shall briefly outline a consistent structure for measuring aircraft flyover noise for all kinds of transport aircraft - jet subsonic, supersonic, STOL, and VTOL. These measurements of flyover noise would be used in certifying new aircraft under standard conditions and also in airport monitoring of actual flyovers under all atmospheric and operational conditions. It will use  $L_{DE}$  as described previously as the basic measurement scale for new certification tests, and for real time monitoring in the field.

### 2.6.1 Q-Class Aircraft Certification Limits

The limits for noise certification should vary with aircraft gross weight to avoid penalizing the larger, more productive aircraft thereby causing two noise operations at a reduced level instead of one operation. It is proposed that there should be created a "Q-class" of certification with noise limits about 10dB lower than the standard case. The structure for noise limits would then look as shown in Figure 2.12 varying with gross weight as it does presently. A new class of limits would be established for aircraft which choose to meet the quieter certification requirements.

The new Q-class can be described as the next type of aircraft for some future time period. In the interim, there may be a need for a set of quiet short haul aircraft of the RTOL, STOL or VTOL types which would be required to meet these quieter limits. As described in reference 29, these "Q-planes" would be allowed into a set of new "Q-ports", which are new airports in urban areas which become acceptable to the surrounding communities if they are guaranteed that only "Q-planes" would be allowed to operate there. Aircraft which would never use Q-ports

Noise Level  
 $L_{DE}$

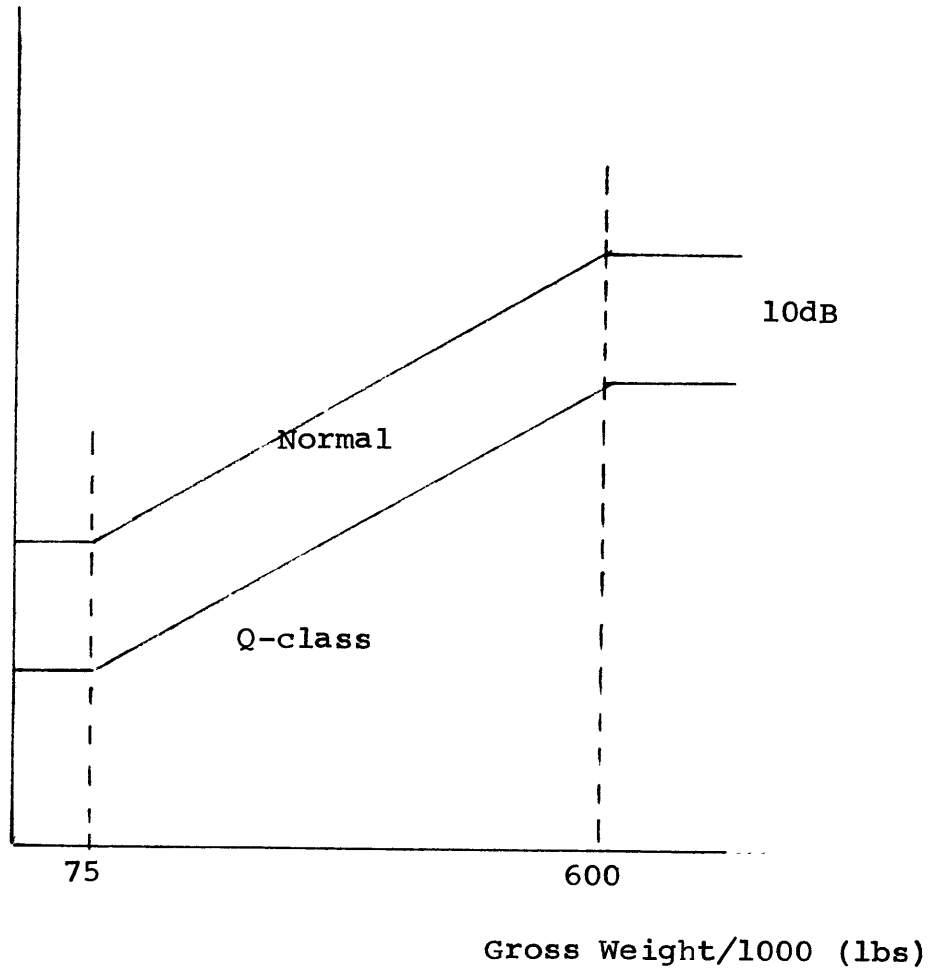

Figure 2.12 STRUCTURE FOR CERTIFICATION NOISE LIMITS



can be built to meet the normal standards without any economic or performance penalty.

#### 2.6.2 Measuring Points for Certification and Monitoring

Because of the wide range of operating paths possible for CTOL, STOL, and VTOL aircraft, and because airport monitoring equipment may have to be placed at various locations relative to different runways, it is proposed that a range of measuring point locations and corresponding limits be specified. This is similar to the present California regulations described in 2.5.3 and figures 2.10 and 2.11. The manufacturer would be required to demonstrate compliance under worst case conditions with a given set of measuring points, with the full knowledge that he will be supplying aircraft to customers who will be required to meet these limits in varying conditions and measuring points in the field.

It is suggested that the three basic measurements of approach takeoff, and sideline be retained. For the approach, the measurement points would range from 2000 feet to 1.0 n. mile from threshold along the approach path. For takeoff, they should range from 2000 feet to 3.5 n. miles along the takeoff path. For sideline noise, it is suggested that a standard 1000 feet displacement line be used to monitor takeoff roll along the runway for both STOL and CTOL, and that a circular line of 1000 foot radius be used to monitor lift off and landing around a VTOL pad. Sideline noise limits should be met at all points along the displacement and circular lines. These measurements lines are shown in Figure 2.13.

This report is not concerned with establishing the levels of  $L_{DE}$  which would be specified in this structure. These should be the outcome of a political process which determines a fair and equitable answer for all parties.

CTOL and STOL

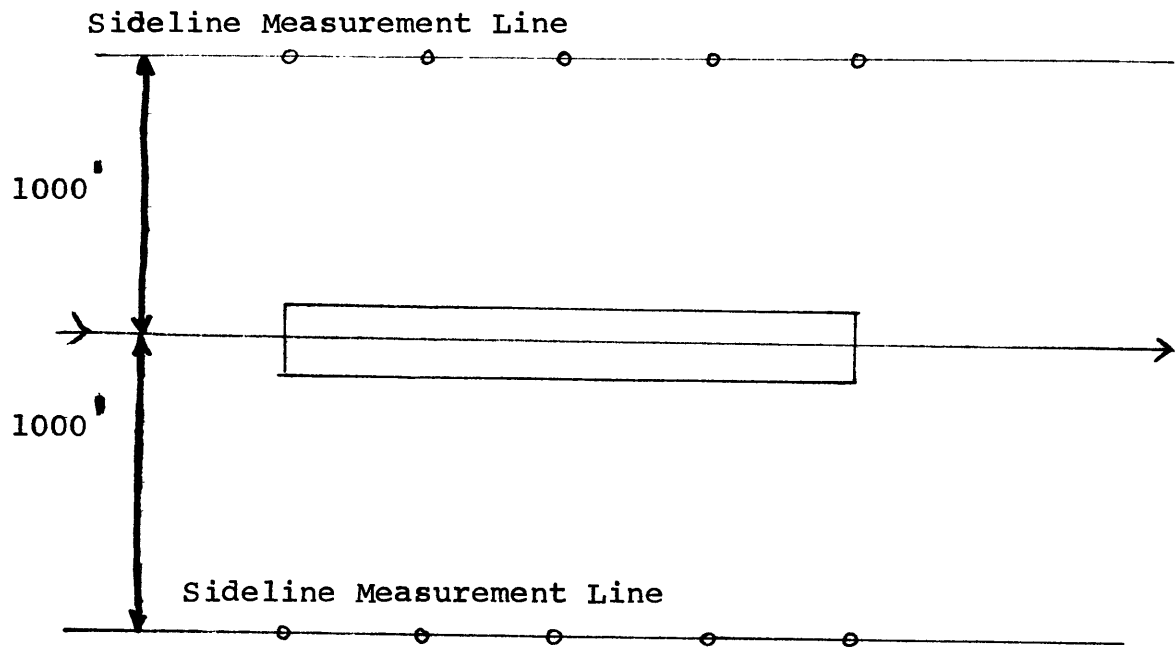

VTOL

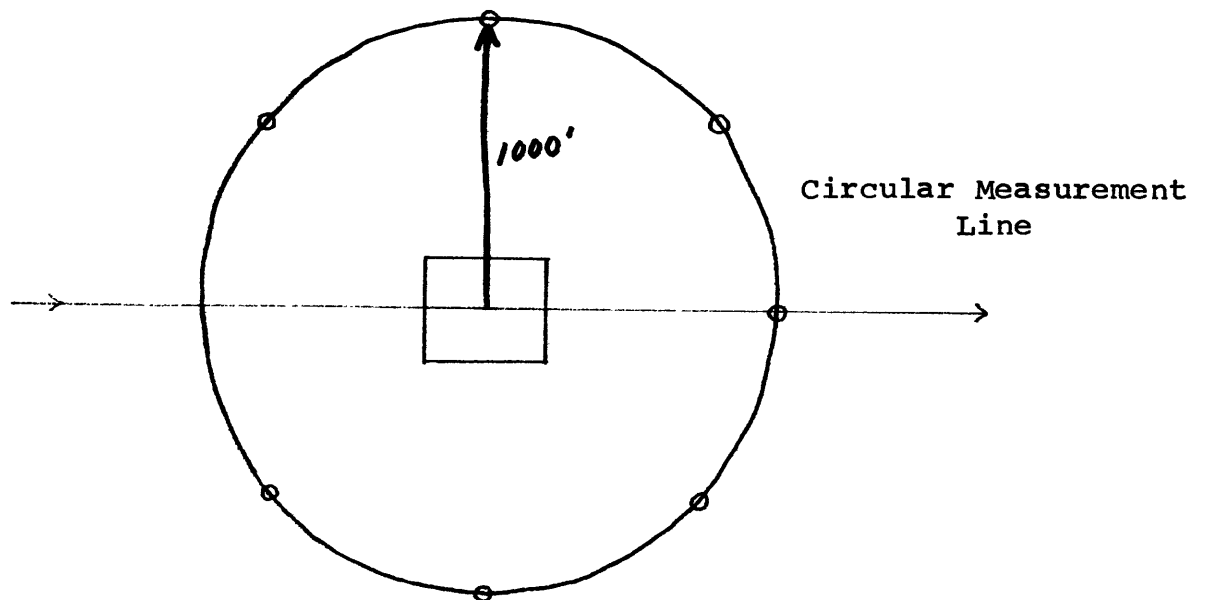

Figure 2.13 MEASUREMENT LINES FOR SIDELINE NOISE

### 3.0 MEASUREMENT AND CONTROL OF AIRPORT NOISE EXPOSURE LEVEL

#### 3.1 Measurement of Multiple Event Noise Level

To a large extent calculation of noise exposure is a modelling process. The model should predict the noise levels of individual flyovers, and by applying corrections for the effect of durations, multiple flyovers and time of day effect, it should determine the total noisiness over time at any given point around an airport. Models of noise exposure have generally only gone this far. Contours have been drawn of equal noisiness and the area within a certain contour has been used as a measure of total noise impact. The formulae that have been used to calculate the cumulative effect of noise are the Composite Noise Rating (CNR), superseded by the Noise Exposure Forecast (NEF), and the Noise and Number Index (NNI) in England. Each of these formulae is described in this section of the report.

##### 3.1.1 Composite Noise Rating

The first attempt to account for the effects of frequency and time of day was the introduction of the concept of Composite Noise Rating by Rosenblith and Stevens in 1952. A history of development of CNR may be found in Reference 17. It is of interest to note that determination of CNR originally involved such factors as impulsiveness of the sound, background noise levels, and the effect of the community's previous exposure to noise. These corrections were mostly intuitive and were later dropped. The concept of CNR has now been largely superseded by the Noise Exposure Forecast (NEF).

The formulation of CNR is as follows:

$$\text{CNR}_j = (\text{LPN}_{\text{max}})_j + 10 \log \left[ (\text{N}_D)_j + 20(\text{N}_N)_j \right] - 12 \quad (3.1)$$

where  $\text{CNR}_j$  is for a single type of operation producing a specific noise characteristic.

$(L_{PN_{max}})$  = the maximum value of  $L_{PN}$  for that noise,

$N_D, N_N$  = the number of day (0700-2200) and and night (2200-0700) operations per 24 hours.

The overall value of CNR for all classes of aircraft is:

$$CNR = 10 \log \sum_j 10^{CNR_j/10} \quad (3.2)$$

### 3.1.2 Noise Exposure Forecast

With the impending introduction of  $L_{EPN}$  as a measure in the certification of new aircraft it was decided to incorporate it into a new community noise measure. Other modifications from CNR are a change in the weighting ratio between day and night flights and a change in the arbitrary constant in order to make NEF numerically significantly different from CNR. The formulation is:

$$NEF_j = (L_{EPN})_j + 10 \log [(N_D)_j + 16.67 (N_N)_j] - 88 \quad (3.3)$$

where  $NEF_j$  is for a single type of aircraft  $j$  producing a specific noise characteristic.

$(L_{EPN})_j$  = the value of  $L_{EPN}$  for the type of aircraft  $j$ .

$(N_D)_j (N_N)_j$  = the number of day and night operations, as for CNR.

The overall value of NEF for all classes of aircraft is:

$$NEF = 10 \log \sum_j 10^{NEF_j/10} \quad (3.4)$$

An indication of response or land use descriptions for values of

NEF is as follows:

NEF < 30      Some noise complaints are possible and noise may interfere with some activities.

NEF = 30-40    Individual reaction may include vigorous repeated complaints, and concerted group action is also a possibility. Construction of homes, schools, churches, etc., should not be undertaken without a complete analysis of the situation.

NEF > 40      Serious problems are likely. No activity, nor building construction should be carried on without a complete analysis of the situation.

### 3.1.3 Noise and Number Index

Noise and Number Index was developed in 1961 to relate the noise levels around Heathrow Airport, London, to the degree of annoyance. The formulation is:

$$\text{NNI} = \bar{L}_{\text{PNM}} + 15 \log N - 80 \quad (3.5)$$

where  $\bar{L}_{\text{PNM}}$  is the energy mean of the maximum values of  $L_{\text{PN}}$ .

N = the number of flights in a given period (one day or one night).

The frequency correction is equivalent to 4.5 dB increase in NNI for every doubling of the number of operations, which is heavier weighting than most other noise measures. More recent research (Ref. 18) indicates that this weighting is too heavy. Reference 19 suggests that a correction may be made in order to produce an expression for NNI that applies to a 24 hour period. It is:

$$NNI' = 10 \log \left( 10^{\frac{NNI_D}{10}} + 10^{\frac{(NNI_N + 17)}{10}} \right) \quad (3.6)$$

where  $NNI_D$  and  $NNI_N$  are the values determined for for day and night respectively.

#### 3.1.4 Noise Pollution Level

A recent attempt has been made to produce a system of noise measurement that can be used for all types of noise (Ref.20). The formulation is:

$$L_{NP} = L_{eq} + k \sigma \quad (3.7)$$

where  $L_{eq}$  is the "energy mean" of the noise level  $L$  over a specific period.

$\sigma$  is the standard deviation of the instantaneous level considered as a statistical time series over the same period.

$k$  is a constant provisionally given the value 2.56. The noise level  $L$  is to be measured in a scale adequately related to subjective noisiness, e.g., dB(A), dB(PN), dB(TPN). Thus:

$$L_{eq} = 10 \log \left[ \frac{\sum_{i=1}^N (n_i 10^{L_i/10})}{N} \right] \quad (3.8)$$

where  $L_i$  is the noise level of the  $i$ th interval.

$n_i$  is the number of times that  $L_i$  occurs.

$N$  is the total number of measurements.

$$\sigma = \left[ \sum_{i=1}^N [n_i (L_i - \bar{L})^2] / N \right]^{1/2} \quad (3.9)$$

where  $\bar{L}$  is the arithmetic mean noise level.

The index  $L_{NP}$  generates a rate of increase of exposure level with number of increases that is steeper than the 3 dB per double number given by the simple concept of energy summation; the relationship is actually nonlinear, growing more steeply in the middle range of occurrences.

### 3.1.5 Hourly Noise Level (California) $L_{HN}$

The Hourly Noise Level ( $L_{HN}$ ) is the basic measurement used for computing the daily Community Noise Exposure Level ( $L_{CNE}$ ) at a given station.  $L_{HN}$  is the average value on an energy basis of the A-weighted sound level over a given hour

$$L_{HN} \approx 10 \log \left[ \frac{1}{3600} \sum_n 10^{L_{SENE}^{(n)}/10} \right] \approx \bar{L}_{SENE} + 10 \log n - 35.6 \quad (3.10)$$

where  $\bar{L}_{SENE}$  is the energy average  $L_{SENE}$  during the hour; n is the total number of single events (flights) during the hour

### 3.1.6 Community Noise Equivalent Level (California) $L_{CNE}$

The total noise exposure for a day is specified by the Community Noise Equivalent Level,  $L_{CNE}$ , in dB, and may be expressed by:

$$L_{CNE} = 10 \log \left[ \frac{1}{24} \left( \sum_{i=1}^{12} 10^{(L_{HN})_D(i)/10} + 3 \sum_{j=1}^3 10^{(L_{HN})_E(j)/10} + 10 \sum_{k=1}^9 10^{(L_{HN})_N(k)/10} \right) \right] \quad (3.11)$$

where  $(L_{HN})_D$  are the hourly noise levels for the

period 0700-1900 hrs.

$(L_{HN}^E)$  are the hourly noise levels for the period  
1900-2200 hrs.

$(L_{HN}^N)$  are the hourly noise levels for the period  
2200-0700 hrs.

If the values of  $L_{SENE}$  are approximately the same then the  
expression for  $L_{CNE}$  is:

$$L_{CNE} = \bar{L}_{SENE} + 10 \log ( N_D + 3 N_E + 10 N_N ) - 49.4 \quad (3.12)$$

where  $\bar{L}_{SENE}$  is the energy average  $L_{SENE}$  during the  
24 hours.

$N_D$  is the total number of flights during the period  
0700-1900.

$N_E$  is the total number of flights during the period  
1900-2200.

$N_N$  is the total number of flights during the period  
2200-0700.

The annual value of  $L_{CNE}$  is:

$$\text{Annual } L_{CNE} = 10 \log \left( \frac{1}{365} \sum_{i=1}^{365} 10^{L_{CNE}(i)/10} \right) \quad (3.13)$$

where  $L_{CNE}(i)$  is the daily value of  $L_{CNE}$ .



## 3.2 Proposed Method of Measuring Airport Noise Exposure Level

### 3.2.1 Hourly Noise Exposure Level

$$\text{Hourly } L_{\text{NEH}} = 10 \log \left[ \frac{1}{3600} \sum_n 10^{(L_{\text{DE}} - L_{\text{DB}})/10} \right] \quad (3.14)$$

where n = no. of operations in the hour.

This is similar to  $L_{\text{HN}}$  in California, except background noise level,  $L_{\text{DB}}$ , appropriate to the time of day is introduced. It performs energy averaging over the multiple aircraft operations within the hour, as perceived at some listening point in the community. Rather than measure actual background levels at these measuring points, it is suggested that a nominal background level, which varies with the time of day, appropriate for a residential area be used. For example, the following background levels are suggested:

Hours 0700-1900,  $L_{\text{DB}} = 75\text{dBD}$  ( 81 PNdB)

Hours 1900-2200,  $L_{\text{DB}} = 70\text{dBD}$  ( 76 PNdB)

Hours 2200-0700,  $L_{\text{DB}} = 65\text{dBD}$  ( 71 PNdB)

This varying background level is intended as a replacement for the arbitrary weighting of flights by time of day used in other measuring systems for noise exposure. If actual background levels are used, this measure relates noise exposure to "intrusive" noise.

### 3.2.2 Daily Noise Exposure Level

$$\text{Daily } L_{\text{NED}} = 10 \log \left[ \frac{1}{24} \sum_{i=1}^{24} 10^{L_{\text{NEH}}^{(i)}/10} \right] \quad (3.15)$$

The daily noise exposure is then simply the energy averaged sum of the hourly noise exposure values.

This system introduces background levels as a factor in measuring community noise exposure. Because background levels are subtracted, the numerical values will be significantly smaller than other measures (except NEF which subtracts 88), and they represent noise above background noise, or intrusive noise. As quiet V/STOL vehicles are introduced, this background level becomes a far more significant factor than it is presently. It is possible for future quiet helicopters to stay below background levels. This measurement scale would then provide a zero  $L_{\text{NED}}$  value in the surrounding communities, quite appropriate to the actual noise exposure.

### 3.3 Regulations for Controlling Airport Noise Exposure Level

At present the question as to who is going to control the noise exposure levels around airports has not been resolved. While the FAA has accepted responsibility for certification of aircraft with respect to noise (FAR Part 36), it has declined responsibility for noise certification of airports or establishing noise exposure levels for surrounding communities. In October 1972, Congress passed the Environmental Noise Control Act charging the Environmental Protection Agency with carrying out studies of "implications of identifying and achieving levels of cumulative noise around airports" and "additional measures available to airport operators and local governments to control aircraft noise". Recommendations from EPA will be considered in a hearing held by the FAA. It will be interesting to see the results of this activity. In the interim, the State of California has made a serious attempt to control airport noise, and various airport operators are developing their own methods of control. It would be desirable to establish a common system of controlling airport noise exposure within which these various parties could operate.

#### 3.3.1 California Airport Noise

A fundamental concept of the California Noise Regulations is that of a 'Noise Impact Area' which is the direct equivalent of the area contained within a certain NEF contour. The major differences are that the 'Noise Impact Area' calculation uses  $L_{CNE}$ , instead of  $L_{EPN}$  and that there are different weightings for daytime, evening and nighttime flights.

A requirement of the regulations is that the 'noise impact area', as applied to residential areas must be zero; that is, the noise exposure for a residential area must be less than a

given value. Thus the regulations do not attempt to minimize the total noise impact, but rather to control the maximum noise exposure level that any residential area could be subject to. Like other regulatory systems which concern people, the regulations are designed to protect people from the worst excesses of the disturbance, rather than minimizing the disturbance itself.

The maximum noise levels which determine the noise impact area for various airports and time periods as promulgated by the California regulations dated November, 1970, are as follows:

- a) For proposed new airports, or military airports being converted to commercial use, the value of  $L_{CNE}$  is 65 dB.
- b) For existing civilian airports with less than 28000 air carrier operations, and no four engine turbojet or turbofan operations, the value of  $L_{CNE}$  is 70 dB until 1986, and 65 dB thereafter.

c) For other existing civilian airports, the values of  $L_{CNE}$  proposed were:

Effective date of regulations to December, 1975 -		
80 dB.		
Jan. 1976 to Dec. 1980	-	75 dB
Jan. 1981 to Dec. 1985	-	70 dB
Jan. 1986 and thereafter	-	65 dB

One should note that the relationship between  $L_{CNE}$  and NEF is roughly:

$$L_{CNE} \approx NEF + 33 \tag{3.16}$$

### 3.4 Proposed Regulations for Controlling Airport Noise Levels

#### 3.4.1 Limits on Hourly and Daily Noise Exposure Level

To control the noise caused by airport operations, it is proposed that airport noise monitoring schemes be adopted which place microphones at selected locations around the airport. These locations would normally be residential areas near the airport which are felt to experience some degree of noise exposure from the airport operations. The microphones would record hourly and daily Noise Exposure Levels as described in the previous section. An annual "energy averaged" value of these measures can also be computed as a running average value over the last 365 days.

It is proposed that federal limits be established for these average annual values of hourly and daily noise exposure levels which may be imposed by airport operations on any residential community. As the average annual values approach these limits, the airport operator would be held responsible for controlling the frequency and type of aircraft operations such as to remain within these limits. If the long term forecasts of demand at a given airport are high, there will be pressures on the airport operator to build another airport or Q-port to serve the region, and pressures on the aircraft operators to use quieter vehicles at that airport.

In the event that communities are already exposed to noises above these limits, it is proposed that a compensation scheme be established. A noise tax can be imposed on all takeoff and landing operations for the noise they actually make as measured by the runway monitor microphones. The funds thus raised can be paid back to the "overexposed" communities based upon the exposure actually recorded by their monitors. The levels of tax can be

adjusted to raise the funds required to meet the compensation levels agreed by the airport operator and the communities. This last process would be managed by local political processes with the "dollar per decibel" rates decided by federal legislation.

These control methods are only possible with the type of measurements recommended by this report. It is important that a consistent set of measurements of this nature be established on a national scale.

## 4.0 MEASUREMENT OF TOTAL COMMUNITY NOISE IMPACT

### 4.1 Measurement of Community Noise Impact

#### 4.1.1 Footprint Area - NEF

Recently, a common method of defining noise impact has been to describe it as the footprint area within a given Noise Exposure Forecast (NEF) contour. This method graphically describes the effect of change of flight frequency and changes in noise level of individual flyovers. When NEF contours are plotted on a map that shows population density the importance of excluding high density areas from the noise impact area can be seen, but it is not quantified.

It is important in estimating noise impact that NEF be calculated using operational rather than certification levels of noise from aircraft. The certification levels are rarely met in practice and a NEF footprint calculated using these values may be quite different from the actual footprint.

The footprint area within a given contour is directly proportional to the strength or intensity of the noise source. If one assumes that subjective annoyance varies as any power of the intensity of received sound, one can show (Ref. 27) that total subjective annoyance summed over a uniform population density of listeners within the contour also varies directly as the intensity of the noise source. Under these assumptions, we have total community annoyance varying directly as footprint area. This suggests use of footprint area to measure total community annoyance as a measure for total community noise impact. This will be developed in section 4.2.

#### 4.1.2 Total Community Annoyance Measure (TCAM)

A community noise impact measure in which the sensitivities of different areas is implicit was proposed by Boeing Vertol (Ref. 24). The measure is called Total Community Annoyance

Measure (TCAM) and is given by:

$$TCAM = \frac{1}{\text{Reference Area}} \iint [L_{EPN} \cdot (AA)] dx_1 dx_2 \quad (4.1)$$

where (AA) is the Annoyance Awareness, which is a function of population density and activity for a given area. The question arises as to whether the tradeoff between noise level and area correct.

In this formulation doubling the area subject to a given noise level doubles the value of TCAM, which is reasonable. But if the area is kept constant, the level will also have to be doubled (e.g., from  $L_{EPN} = 80$  to  $L_{EPN} = 160$ ) to achieve the same doubling of TCAM. This is clearly not reasonable, which suggests that the tradeoff is incorrect.

#### 4.1.3 Community Sensitivity Weighting - W

Another community noise impact measure, which does appear to make the right tradeoff between noise level and number of people annoyed, has been developed by Tracor, Inc. (Ref. 25). This is the Community Sensitivity Weighting (W),

$$W = \int_S p(x,y) N(x,y) dx dy \quad (4.2)$$

where  $p(x,y)$  = population density

$N(x,y)$  = "effective" noy value

$$= 10 \left( \frac{L_{EPN} - 40}{33.2} \right)$$

S = area covered by the community.

In the Tracor formulation, there is a further correction for the effect of a large number of flights over a short period, called the "dwell" effect.



Here the community impact is measured in "people-annoyance". The annoyance scale is measured in "noys" which vary as the square root of sound intensity levels above  $L_{EPN} = 40$ .

#### 4.1.4 Aircraft Sound Description System

The Office of Environmental Quality within the FAA has recently proposed a method of describing noise impact called ASDS (Aircraft Sound Description System, Ref. 26). It uses the footprint area within the 100 EPNdB contour as a measure of noise impact. Each takeoff or landing is assumed to take exactly 20 seconds (or 1/3 minute), and an attempt is made to use actual operational noise levels from aircraft rather than certificated levels.

For example, a B727 at 150 knots is assumed to have a given contour and footprint area of size  $x$  under actual operating and atmospheric conditions. If  $n$  operations of this nature occurred at an airport, the footprint area is summed and then divided by three, and the result is declared to be a noise impact of  $\left(\frac{n \cdot x}{3}\right)$  with "dimensions" of acre-minutes.

Notice that the assumption of 20 seconds per operation produces the factor of 1/3, and allows one to arbitrarily give this measure the dimension of time. In actual fact, this impact measure (ASDS) can be viewed as a simple summation of the acres of footprint area of a number of multiple operations, which is then divided by three. This acreage value turns out to be identical to the acreage within the NEF=12 contour (see Appendix A) so that one can write:

$$3 \cdot (\text{ASDS}) = \text{Footprint area for NEF} = 12$$

Viewed in this way, ASDS is simply a footprint area for an NEF contour. Because of the use of overlay charts and standard

footprint areas, it is easier to calculate manually than the previous NEF methodology. (See figure 4.1)

This method may be used by people who are not acquainted with details of the subjective effects of aircraft noise, and does not require a computer for the determination of the value of acre-minutes. As such it is a convenient and easily understood method of describing aircraft noise impact on communities.

However, it is also important that this measure should reasonably correlate with actual subjective reaction to a given noise impact. In the calculation of the number of acre-minutes of noise impact, the population distribution or land use is apparently not considered. Even if overlays are used, so that population distribution within the 100EPNdB contours can be examined, it is difficult to evaluate the effect of frequency. The community just outside a 100 EPNdB contour would not be considered to be subject to noise impact, however high the frequency might be; a community just inside the 100 EPNdB contour would be considered to be impacted by noise, even if there is only 1 flight a day, & would be given on equal rating of impact compared to another community lying just inside the 110 EPNdB contour. Also the assumption of an arbitrary exposure time of 1/3 (or 1/4) minute is not valid at all points in the impact area. For these reasons, the value in "acre-minutes" is an inaccurate measure of community noise impact.

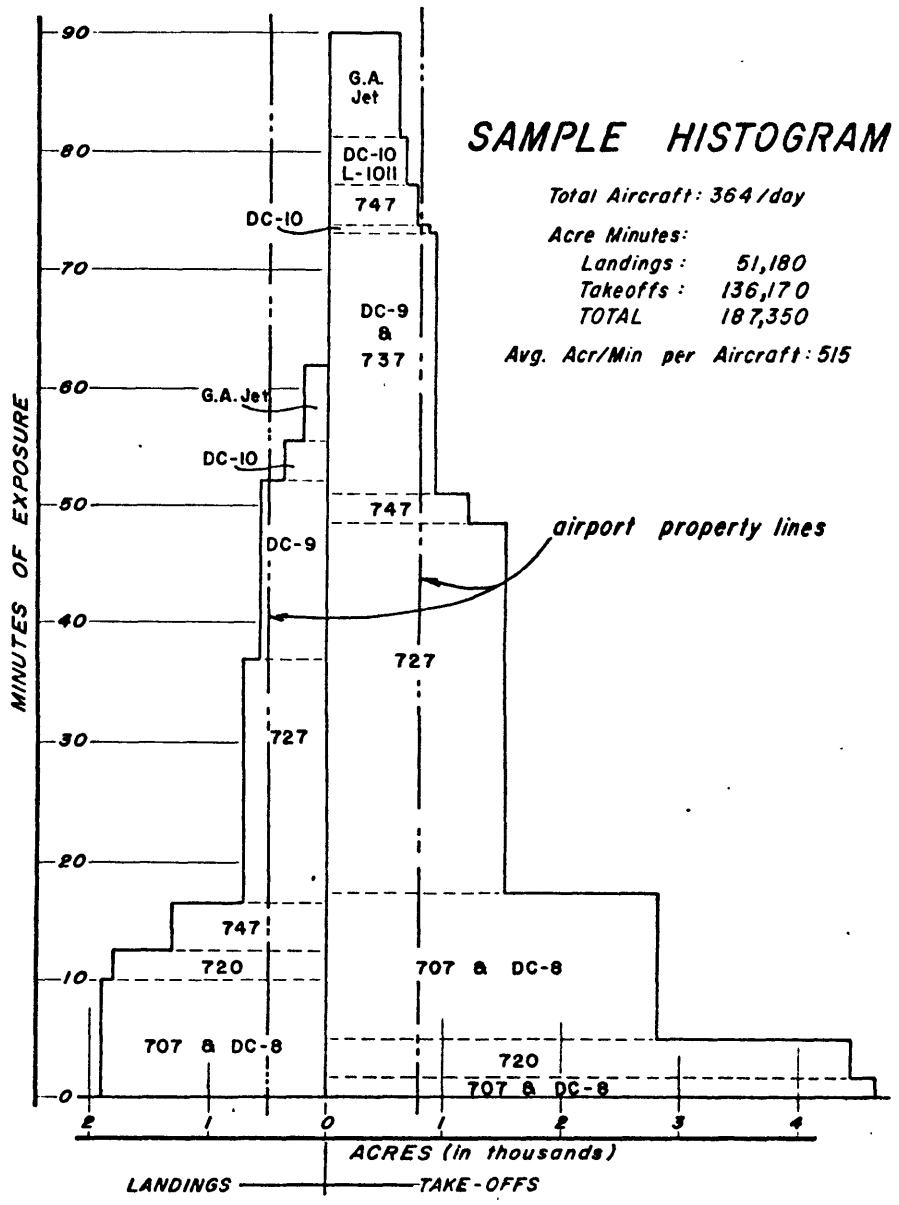

Figure 4.1 EXAMPLE OF CALCULATION OF ASDS (Acre-Minutes)

## 4.2 Proposed Method of Measuring Community Noise Impact

The following section deals with a proposal to determine noise impact as outlined in the introduction.

### 4.2.1 Community Annoyance Number

For measuring the overall impact of aircraft operations on the community, we define a number called the Community Annoyance Number (CAN) which has the dimensions of "people-annoyance". This unit is a development of a similar annoyance measure for single events used by Tracor, Inc. (Ref. 21). The unit is defined as:

$$CAN = \int_A \rho(x,y) \cdot M(x,y) \, dx \, dy \quad (4.4)$$

where  $\rho(x,y)$  is population density at point  $(x,y)$   
 $M(x,y)$  is the Annoyance Number, akin to the noy **and** a measure of annoyance caused by multiple noise events above a background level.

A is the area within which the aircraft noise is above the background noise.

The noy was originally defined as a unit of annoyance for which a person subjected to a noise corresponding to 2 noys was twice as annoyed as when he was subjected to 1 noy. The parameters of the original definition took 40 dB at a frequency of 1,000 cps as a quiet level for reference, and assumed that annoyance varied as the .3 power with noise levels above this reference (Reference 22, 23).

Here we shall change the reference level to background as measured on a D-weighted scale and retain the .3 power assumption. We shall also assume that the effect of multiple events can be summed on an energy basis.

For a single aircraft operation:

$$CAN = \int_A \rho(x,y) \cdot N(x,y) \, dx \, dy \quad (4.5)$$

where  $N(x,y)$  = a modified noy based on the intrusive noise at point  $(x,y)$

$A$  = area outside of the airport boundary

$(x,y)$  = a point location

The modified noy,  $N(x,y)$  may be defined as:

$$N(x,y) = 10 \left( \frac{L_{DE}(x,y) - L_{DB}(x,y)}{33.2} \right) \quad (4.6)$$

$$\text{or } N(x,y) = \left[ \sum_{k=0}^{d/\Delta t} 10 \left( \frac{L_D(x,y)_k - L_{DB}(x,y)}{10} \right) \right]^{.3} \quad (4.7)$$

where  $K = K^{\text{th}}$  increment of time

$L_{DE}$  = aircraft effective noise level as defined in section 2.4.1

$L_{DB}$  = background noise level

This measures the total impact in "people-annoyance" for a given aircraft operation at a given runway under varying take-off or landing profiles, paths or procedures. It is also useful in comparing the impact of a given aircraft on different runways of a given airport.

For multiple aircraft operations we can define a "Multiple Annoyance Number" for both hourly and daily periods.

$$M_H(x,y) = \left[ \sum_n 10 \left( \frac{L_{DE}(x,y) - L_{DB}(x,y)}{10} \right) \right]^{.3} \quad (4.8)$$

where  $n$  = number of operation in the hour.

Since

$$L_{NEH} = 10 \log \left[ \frac{1}{3600} \sum_n 10 \left( \frac{L_{DE} - L_{DB}}{10} \right) \right] \quad (4.9)$$

Then

$$M_H(x,y) = \left[ 3600 \cdot 10 \left( \frac{L_{NEH}(x,y)}{10} \right) \right]^{.3} \quad (4.10)$$

Then, the hourly community annoyance number  $CAN_H$ :

$$CAN_H = \int_A \rho(x,y) \cdot M_H(x,y) \cdot dx \cdot dy \quad (4.11)$$

This measures the total impact in people-noys for an hourly operation of aircraft on a given runway. It is a useful measure for operating a preferential runway system to minimize the noise impact on the surrounding region under varying wind conditions.

For longer term planning, it is necessary to define a daily community annoyance number,  $CAN_D$ :

$$CAN_D = \int_A \rho(x,y) \cdot M_D(x,y) \cdot dx \cdot dy \quad (4.12)$$

Where

$$M_D(x,y) = \left[ 24 \cdot 10^{L_{NED}(x,y)/10} \right]^{.3} \quad (4.13)$$

This measures the total impact in people-noys for a day or an average day as forecast for a runway, or set of runways. It may be used as a measure for siting a new runway, or airport, and for assessing the benefits from retrofit of nacelles or engines to existing aircraft.

This measure for community noise impact is consistent with the measures proposed for aircraft and airport noise. It introduces population density and background noise level as variables which are essential in measuring community noise impact for a given airport. It has the dimensions of "people-annoyance" for impact. A doubling of the value of CAN will indicate either that twice as many people are being annoyed, or that twice as much annoyance (measured in noys) is being imposed on the same people. Operational procedures such as the power cutback will not substantially change this measure of noise impact. The measure may be computed in real time from community noise monitoring systems and used to direct preferential runway operations throughout the day.

## 5.0 SUMMARY REVIEW

The proposed system of aviation noise measurement and control may be briefly summarized by listing the following items.

### 5.1 Measurement of Aircraft Flyover Noise

Use  $L_D$  as a scale for measurement of noise level in order to be compatible with monitoring hardware. Adopt a 3 dB per double duration correction with a nominal breakout level such as 80 dB(D) to define an "Aircraft Effective Noise Level,  $L_{DE}$ " to measure flyover noise. Abandon the measurement of "perceived" noise.

### 5.2 Regulation of Aircraft Flyover Noise

Adopt a system of noise limits measured by  $L_{DE}$  for both certification and operational flyover noises which vary with gross weight of vehicle. Adopt a class of "Q-limits" for quiet aircraft for urban short haul service which new aircraft designs may elect to meet, and which new airports called "Q-ports" may elect to require for operations.

Adopt a range of measuring points for landing, takeoff, and sideline to accommodate CTOL, RTOL, STOL, and VTOL aircraft, and varying airport monitor locations.



### 5.3 Measurement of Airport Noise Exposure Level

Using "Aircraft Effective Noise Level,  $L_{DE}$ " above nominal levels of community background noise for daytime, evening, and night operations, adopt energy averaged measures for hourly and daily "Airport Noise Exposure Level,  $L_{NE}$ ". These can be recorded and computed by noise monitoring equipment for various locations in surrounding communities.

### 5.4 Regulation of Airport Noise Exposure Level

Adopt limits on the annualized value of hourly and daily noise exposure levels which may be experienced by any community in the nation as recorded by monitoring equipment. The airport operator will be responsible for controlling frequency of operations to remain within these limits through quotas, curfews, and the supply of additional airport capacity for the region.

Adopt a compensation scheme for communities in the event that these community noise exposure limits are exceeded. Federally established "dollar per decibel" rates will determine funds to be paid for noise over-exposure as recorded by community noise exposure monitoring equipment. These funds will be raised by noise fees to be paid by aircraft operators based on actual flyover noise recorded by the airport runway monitors.

•

### 5.5 Measurement of Total Community Noise Impact

Using "Airport Noise Exposure Level,  $L_{NE}$ " adopt a new measure called "Community Annoyance Number, CAN" to determine the impact of noise operations over time and population in the surrounding communities. This measure has the dimensions of "people-annoyance". It can be computed in real time using the community noise exposure monitors, and used to determine preferential runway procedures. Longer term forecasts of CAN may be used for siting new runways or airports, and for determining the benefits from changes in aircraft operational procedures or noise retrofit changes at a given airport.

## REFERENCES

1. "A Study of the Magnitude of Transportation Noise Generation and Potential Abatement", Volume II. Serendipity, Inc. Report OST-ONA-71-1. November 1970.
2. "Aircraft Noise Evaluation", FAA Report No. FAA-No-68-32. September 1968.
3. Ollerhead, J.B., Subjective Evaluation of General Aviation Aircraft Noise, FAA No-68-35, April 1968.
4. Ollerhead, J.B., An Evaluation of Methods for Scaling Aircraft Noise Perception. NASA CR-1883 October 1971.
5. Kryter, K.D., "Annoyance" in Transportation Noises (ed. Chalupnik) Washington U. Press 1970.
6. Feiler, C.E. et al "Fan Noise Suppression" Aircraft Engine Noise Reduction Conference May 16-17, 1972. NASA SP-311
7. Little, J.W., Mabry, J.E. "Sound Duration and its Effect on Judged Noisiness" Journal of Sound and Vibration (1969) 9 (2) 247-262
8. Kryter, K.D., Pearsons, K.S. "Some Effects of Spectral Content and Duration on Perceived Noise Level" Journal of the Acoustical Society of America , Vol. 36, 1964.
9. "Supporting Information for the Adopted Noise Regulations for California Airports" Report No. WCR 70-3(R) Wyle Laboratories January 1971.
10. Anon Automatic Aircraft Noise Monitoring System General Radio Preliminary Proposal Q 039.
11. "Federal Aviation Regulations, Part 36. Noise Standards: Aircraft Type Certification", FAA FAR Volume III part 36, November 1969.
12. Metzger, F.B., Foley, W. M. STOL Aircraft Noise Certification - A Rational Approach SAE 700325 April 1970.
13. Anon Conference on STOL Aircraft Noise Certification FAA No-69-1 January 1969.

14. Lowson, M.V. "Noise Radiation from V/STOL Aircraft" International Council of the Aeronautical Sciences Paper 72-22 September 1972.
15. Anon Community Reaction to Airport Noise Tracor Inc. NASA CR-1761 Vol. I. 1970.
16. Vittek, J.F. "Airport Noise Control" to be published in Journal of Air Law and Commerce.
17. Galloway, W.J., et al, "Noise Exposure Forecasts: Evolution, Evaluation, Extension and Land Use Interpretations", FAA- No.-70-0, August 1970.
18. "The British Airports Authority: Report and Accounts 1970-1971", BAA July 1971.
19. "Community Reaction to Airport Noise", Volume I, Tracor, Inc. NASA CR-1761, July 1971.
20. Robinson, D.W., "Towards a Unified System of Noise Assessment" J. Sound Vib (1971) 14(3), 275-298.
21. Patterson, H.P. Preliminary Evaluation of the Effect of a Dynamic Preferential Runway System Upon Community Noise Disturbance, Tracor Inc. NASA CR-12581 N72-20250.
22. Stevens, S.S., "The Measurement of Loudness" Journal of the Acoustical Society of America Vol. 27 No. 5, September 1955.
23. Stevens, S.S., "Calculation of the Loudness of Complex Noise" Journal of the Acoustical Society of America Vol.28, No. 5 September 1956.
24. Stepniewski, W.Z., Schmitz, F.H., "Noise Implications for VTOL Development", SAE 700286, April 1970.
25. Patterson, H.P., et al "Preliminary evaluation of the effect of a Dynamic Prederential Runway System Upon Community Noise Disturbance" N72-20250, NASA CR-125821 Tracor, Inc., Feb. 1972.
26. Anon Aircraft Sound Description System FAA Draft Order 7040
27. Simpson, R.W., Hays, A.P., "The Relationship between Total Community Annoyance and Noise Intensity", FTL Technical Memo 73-1, January 1973.

28. Hwoschinsky, P.V., Factors in Aircraft Noise Generation and Transmission. MIT Flight Transportation Laboratory Technical Memorandum 72-2.
29. Simpson, R.W., (editor), Summary and Recommendations - NASA/MIT Workshop on Short Haul Air Transportation, FTL Report R71-4, October 1971.

SELECTED BIBLIOGRAPHY

Blumenthal V.L., et al Summary, Noise Reduction Research and Development Boeing Company Report Nov. 1971.

Sternfeld, H., Acceptability of VTOL Aircraft Noise Determined by Absolute Subjective Testing. NASA CR-2043 June 1972.

Clarke, F.R., Kryter, K.D., The Methods of Paired Comparisons and Magnitude Estimation in Judging the Noisiness of Aircraft NASA CR-2107 August 1972.

Clarke, F.R., Kryter, K.D., Perceived Noisiness Under Anechoic, Semi-Reverberant and Earphone Listening Conditions NASA CR-2108 August 1972.

Johnston, G.W., V/STOL Community Annoyance due to Noise, Proposed Indices and Levels University of Toronto UTIAS TN-177.

Hays, A.P., Aircraft Noise Criteria MIT Flight Transportation Laboratory Technical Memorandum 72-3

APPENDIX A

The Relationship between ASDS and NEF Footprint Acreage

Suppose the acreage within the  $L_{EPN}=100$  contour for an aircraft/operation of type  $j$  is given by  $A_j$ . From Reference 28, we know that this area is proportional to the source power, or source intensity  $I_{oj}$ ;

$$A_j = k \cdot I_{oj} \quad (A.1)$$

i.e. doubling the source intensity by flying two aircraft simultaneously would double  $A_j$ , or double the intensity at any point on the ground, (or raise  $L_{EPNj}$  at that point by 3dB).

In constructing NEF for the case where aircraft fly the operations serially instead of simultaneously, an assumption has been made to "energy average", or to simply sum the effect as though all the operations took place simultaneously. For  $n_j$  daytime flyovers, if we measure  $NEF_j$  at any point:

$$NEF_j = L_{EPNj} + 10 \log (n_j) - 88 \quad (A.2)$$

or

$$NEF_j + 88 = L_{EPNj} + 10 \log (n_j) \quad (A.3)$$

If we unlog this expression to measure intensity directly, we obtain:

$$\begin{aligned} 10^{(NEF_j + 88)/10} &= 10^{L_{EPNj}/10 + \log (n_j)} \\ &= n_j \cdot (10^{L_{EPNj}/10}) \end{aligned} \quad (A.4)$$

This states that the intensity measured at the given point for a single flyover is increased  $n_j$  times by the NEF calculation. That is, it is equivalent to increasing source strength  $n_j$  times, and this would result in the footprint area for any given intensity level being increased  $n_j$  times from A.1.

Therefore, the footprint area for a level where  $NEF+88 = 100$  would be  $n_j$  times the footprint area for  $L_{EPNj} = 100$ ;

$$A_{NEF=12} = n_j \cdot A_j \quad (A.5)$$

Now, the value of ASDS as given in acre-minutes is:

$$ASDS = \frac{1}{3} \cdot n_j \cdot A_j \quad (A.6)$$

Therefore, for  $n_j$  daytime operations by aircraft type j:

$$3 \cdot (ASDS) = A_{NEF=12} \quad (A.7)$$

Similarly, if there are also  $n_k$  operations of aircraft type k the summation occurs at the energy or intensity level of equation A.4.

$$\text{i.e. } 10^{(NEF + 88)} = n_j \cdot (10^{L_{EPNj}/10}) + n_k \cdot (10^{L_{EPNk}/10}) \quad (A.8)$$

Thus, the equivalent source strength is incremented proportionally to the source strengths of each flyover, or the footprint areas are additive. We can now state the following: "For daytime operations, the value of the acreage within the NEF=12 contour is three times the value of ASDS as expressed in acre-minutes".