

The Convergence of Sustainable
Technologies and Architectural Design Expression

by

Jason Patrick Phillips

Bachelor of Architecture
University of Arizona, 2001

Submitted to the Department of Architecture
in Partial Fulfillment of the Requirements for the Degree of

Master of Science in Architecture Studies

at the

Massachusetts Institute of Technology

June 2003

© 2003 Jason Patrick Phillips
All rights reserved

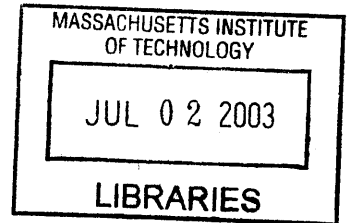

The author hereby grants to MIT permission to reproduce and to
distribute publicly paper and electronic copies of this thesis document in whole or in part.

Signature of Author.....
Department of Architecture
May 22, 2003

Certified by.....
William Porter
Norman B. and Muriel Leventhal Professor of Architecture and Planning
Thesis Supervisor

Accepted by.....
Julian Beinart
Chairman, Department Committee on Graduate Students

ROTCH

THESIS COMMITTEE

Thesis Advisor

William Porter

Norman B. and Muriel Leventhal Professor of Architecture and Planning

Thesis Reader

Stanford Anderson

Professor of History and Architecture; Head, Department of Architecture

Thesis Reader

John Ochsendorf

Assistant Professor of Building Technology

The Convergence of Sustainable Technologies and Architectural Design Expression

by

Jason Patrick Phillips

Submitted to the Department of Architecture on May 22, 2003
in Partial Fulfillment of the Requirements for the Degree of
Master of Science in Architecture Studies

ABSTRACT

In recent years an unprecedented ecological awareness has taken hold, not only within the discipline of architecture, but throughout our society as well. No longer are we, as a culture, accepting of the long established traditions of buildings holding dominion over nature at all cost and without consequence. Today there is concern with bringing mankind and all things manmade into a benign harmony with our natural environment.

Architects can no longer be content with simply satisfying basic requirements of health, safety and welfare in their buildings. More esoteric investigations into the poetics of space, theoretical experimentation, or symbolic reference also are not enough. A new layer of expertise and understanding is now required of our discipline. The pursuits of design expression must now work in tandem with the advancement of sustainable technologies to achieve an architecture that responds in a positive and sensitive way to the environment in which it resides. Sustainable issues have become a significant participatory, yet not dominate, element within architectural design. It is the position of this thesis that there is a recent—and widespread—convergence of sustainable technologies and design expression that is occurring and affecting the entire discipline of architecture. The logical synthesis of technology and design is fundamentally altering not only what is built, but also how it is built. The physical implications of this convergence on contemporary architecture are that it is creating a new formal vocabulary never seen before. In many cases, a new typology is emerging.

This thesis is primarily focused on identifying the physical architectural evidence associated with this convergence. The physical manifestation of the synthesis of sustainable technologies and design expression can be seen in a wide range of projects throughout the discipline and is bound by no aesthetic or formal category. These concerns have seemingly transcended all formal categorization, and are affecting architecture regardless of function, style, or theoretical position. Whereas once sustainability was relegated to its own category, today it has become apart of all categories. It is important to identify this phenomenon; understand how it is affecting the discipline of architecture; and to realize where the industry is going as a result.

Thesis Supervisor: William Porter

Title: Norman B. and Muriel Leventhal Professor of Architecture and Planning

ACKNOWLEDGMENTS

I would like to thank Bill Porter for his continued support, guidance and contribution to this thesis. Bill, your wisdom and kindness will be with me for the rest of my life.

I would also like to thank my readers Stanford Anderson and John Ochsendorf. Thank you for your encouragement and critical discussion. Your involvement has given this work a level of depth that would not have been possible without you.

Most of all I would like to thank my wife, Stacey. Only because of you was this possible.

TABLE OF CONTENTS

<i>Chapter 1</i>	
Establishing a Context.....	6
<i>Chapter 2</i>	
A Brief History of Sustainability.....	14
<i>Chapter 3</i>	
Norman Foster: Leading the Way.....	32
<i>Chapter 4</i>	
Richard Meier: From White to Green.....	52
<i>Chapter 5</i>	
The Emergence of Sustainable Practice in Superstructures.....	67
<i>Chapter 6</i>	
Making an Argument.....	91
<i>Bibliography</i>	114

Chapter 1

Establishing a Context

The discipline of architecture in the twentieth century can be defined by the emergence of the Modern movement and the multiple variations of the movement that ensued. While significant, and founded upon noble, socially-driven intentions, it may be argued that later variations of the Modern movement, eventually, evolved primarily into pursuits of style, metaphorical rhetoric, diagrammatic expression, aesthetic and formal play. As exceedingly esoteric discourse became fashionable, architecture became increasingly superficial. While this may be a hyper-critical, over-simplification of late-twentieth century high-design, it is becoming a widely recognized judgment. As the Modern movement broadly influenced twentieth century architecture, what movement will define architecture in the twenty-first?

As contemporary society becomes increasingly aware and concerned with ecological issues, more is expected of the discipline. Many of the established architectural practices and traditions of the past are not acceptable today. In a departure from twentieth century modernist tendencies, it is no longer desirable for architecture to hold dominion over nature. Today it is necessary for buildings to participate in the creation of a logical, symbiotic balance between the built and natural environments. The discipline of architecture is discovering renewed responsibility through the acknowledgement of legitimate concerns; the health and well-being of its occupants, environmental accountability and the efficiency of buildings. While not denying formal expression and aesthetic vision, efficiency and sustainability are becoming participatory elements within architectural design.

It is the position of this thesis that this recent repositioning of attitude and concern has caused a convergence of sustainable technologies and architectural design expression. The pursuits of sustainability and design are no longer mutually exclusive endeavors. Today's notion of environmental responsibility has become integrated to all architectural stylistic categories, unlike sustainability of the past which primarily existed within

its own marginalized grouping. This convergence is fundamentally affecting the discipline of architecture in both process and product. As a result, a new formal vocabulary is emerging.

This thesis seeks to identify and examine the physical evidence of this recent movement. The physical manifestation of the synthesis of sustainable technologies and design expression can be seen in a wide range of projects throughout the discipline and is bound by no aesthetic or formal category. These concerns have seemingly transcended all formal categorization, and are affecting architecture regardless of function, style, or theoretical position. While the emergence of a new formal vocabulary is clearly indicative of a change in design process, this discussion will refrain from addressing this issue. While, acknowledged as important, the concern of process requires its own investigation. The issue of product—or physical evidence—is significant enough to necessitate its own discussion. We will address this change in formal vocabulary within the discipline of architecture and hypothesize as to how it is affecting the industry.

To investigate this stated convergence we will employ a method of research focused around various case studies that are indicative of specific emerging concerns. The projects examined represent a wide cross-section of the discipline and a myriad of formal and aesthetic categories. Because it would be unfeasible, and unnecessary, to consider every recent project that is relevant to our discussion, many of the case studies chosen are representative of numerous similar works not addressed. The projects examined here are primarily high profile works by notable architects. The benefit of using identifiable works is that they are both physically and intellectually accessible to a large audience. As well, high profile projects are usually indicative of emerging concerns and trends within the discipline.

After a brief discussion of the influence and multiple trajectories of past sustainability movements, we begin by exploring contemporary architects who have committed their entire careers to the pursuit of environmentally responsible architecture. Architects such as Norman Foster, Renzo Piano, Nicholas Grimshaw and Thomas Herzog are a

handful of designers who anticipated the current redirection of the discipline toward greater environmental consciousness. For decades they have attempted to synthesize their respective design visions with environmentally sensible technologies and techniques. While their work is not indicative of recent trends within the discipline—since they have continuously been concerned with these issues—their architecture does provide valuable examples of how sustainable technologies can both inform, and be informed by, design expression. These influential designers were once a small yet respected faction within the discipline. Today however, much of the industry looks to them, and their work, as a paradigm of how technologies and techniques may be utilized in the pursuit of environmentally responsible buildings. For this reason, we regard them as standard-bearers.

The discussion continues by addressing architects who have only recently directed their attention toward issues of building efficiency and sustainability. This group of architects is fundamental to the position and arguments of this thesis. Their work demonstrates most clearly the profound affect that the convergence of design and sustainable technologies can have on architecture. Their work



Cite Internationale, Piano, 1995.

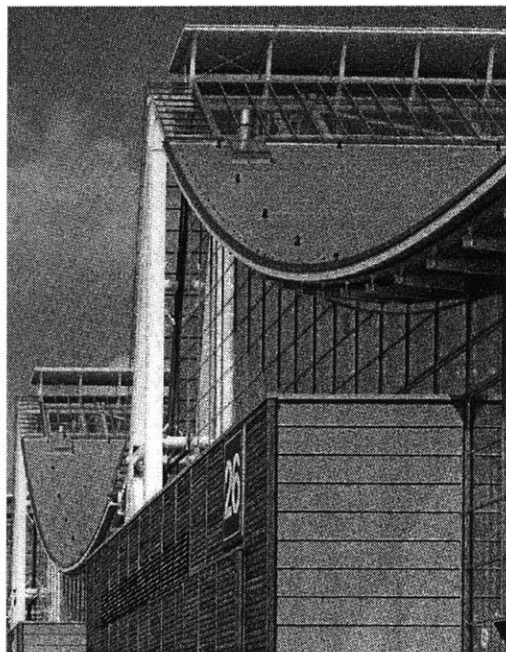

Exhibition Hall, Herzog, 1996.

provides fascinating case studies in that they offer insight into how designers inexperienced with sustainable technologies are attempting to address these issues with varying levels of success. Most significant about the architecture of these designers, is the transformation in formal vocabulary as a result of the integration of sustainable technologies. By comparing and contrasting their early work and design intentions with their later work, a profound change is apparent. As with the standard-bearers mentioned above, we will choose a limited number of architects to discuss in detail to serve as representative of countless others.

Our last category of case studies will focus on the recent phenomenon associated with the augmentation of sustainable practices in mega-scale architecture. This widespread trend is easily identifiable due to the high budget—hence high profile—nature of high-rise buildings. The formal implication of sustainable technologies utilized in these structures is generating a new typology in architecture never seen before. This fact offers significant support to the position of this thesis. The cultural and economic forces behind this occurrence in high-rise construction substantiate the argument that there is an emerging environmental consciousness in

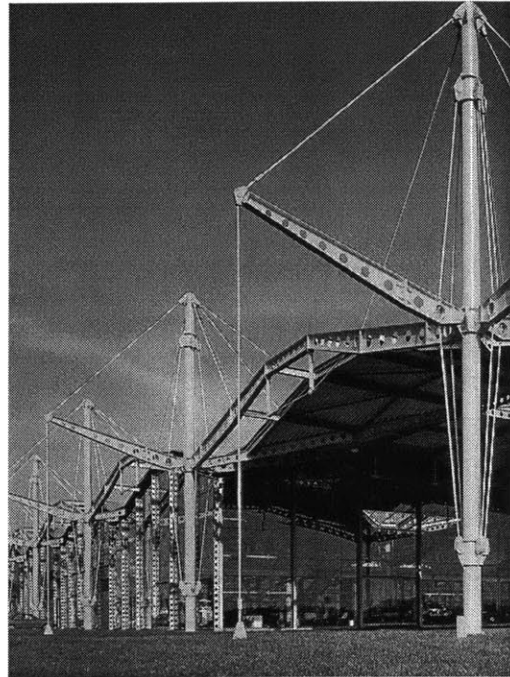

Renault Distribution Center, Foster, 1982.

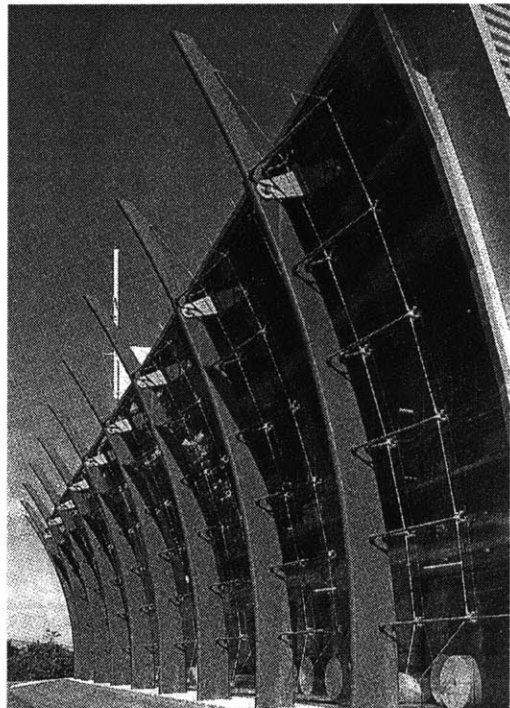

Western Morning News Headquarters,
Grimshaw, 1993.

our society. Through an investigation of these current constructions, a pattern of transformation emerges. And while high-rise construction is but a small percentage of the industry, a fundamental repositioning of intentions here is representative of concerns within the entire discipline.

Our discussion concludes in the final chapter of this thesis as we revisit the case studies that are investigated in thorough detail in preceding chapters. Will we summarize the main arguments of this paper and discuss them in concert using all previously discussed projects as vehicles and examples to solidify arguments. The recent convergence of sustainable technologies and architectural design expression will be a connecting thread that resonates throughout all chapters and all case studies presented.

We will also establish that through these works of varying scale, style and theoretical position, connectivity exists. This thesis will postulate that the shared environmental intentions of architects from across the discipline are central to the emergence of a new architectural typology. Although formally diverse, many of these projects achieve similar levels of integration between sustainable technologies and other building systems that

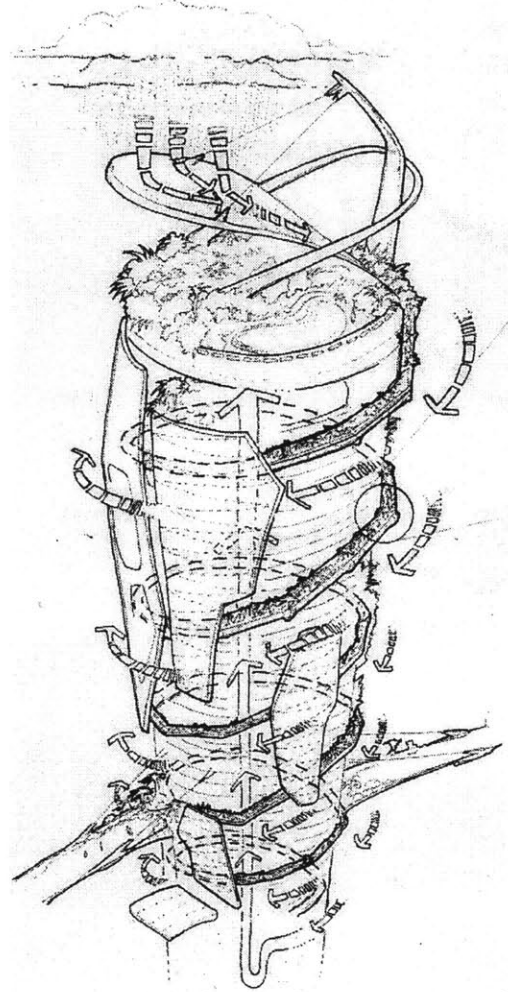

Menara Mesiniaga Building,
Hamzah and Yeang, 1992.

is unique to this current movement. And although implemented in different ways, this integration is primary to the recent acceptance of sustainability. Sustainable technologies have become a participatory feature within larger architectural pursuits.

Significant scientific and empirical research is required when attempting to bridge the disparity between architectural design and sustainability; two historically autonomous pursuits. Being rigorous with regard to methods of assessment of existing and emerging technologies is fundamentally important to the advancement and future success of building technologies. Without this persistence, the effectiveness of such technologies will remain an unfulfilled ambition, and never achieve their environmental objectives. It is prudent to be critical of sustainable technologies for the purpose of advancement; however, one must also be realistic with expectations placed upon the effectiveness of current technologies.

The buildings discussed in this thesis are not comprehensively sustainable projects. And although they are presented in a positive light, it is acknowledged that they are simply the beginnings of a movement founded upon environmental concerns. However, each project to be discussed is important—for one reason or another—to the advancement of the convergence of sustainable technologies and architectural design. As the pursuit of these technologies is still in its infancy, it is one of the positions of this thesis that, currently, the intentions behind many of these projects are more important than the tangible successes. If architecture maintains its intentions of environmental responsibility, inevitably, technologies and techniques will produce their desired objectives. Therefore, it is considered acceptable, for the purpose of our discussion, to investigate building that only partially or marginally succeed in their efforts toward sustainability.

This investigation of the convergence of sustainable technologies and design expression is undertaken here due to its acute relevance to the state of contemporary architecture. It is the contention of this thesis that this issue—above all others—will be what defines the discipline in the twenty-first century. And although the digital revolution in

computer technologies and software are progressing daily—altering the process by which architecture is designed and built—these developments are but a means to an end, and not an end in themselves. The advancement of digital technologies will prove invaluable to the pursuit for a more sustainable and responsible architecture. However, it is essential to focus on the paramount issues facing all of mankind in the coming century; the question of future energy resources, environmental responsibility, and the health and success of generations to come. In the twentieth century buildings contributed greatly to the destruction of the environment and the consumption of natural resources. It is the position of this thesis that twenty-first century architecture will necessarily be defined by the pursuit of reversing this trend. The case studies and discussion that follow are the beginnings of this pursuit.

Chapter 2

A Brief History of Sustainability

It may be argued that the existence of environmentally responsible and effective constructions dates back to the very infancy of human existence in the traditions of early vernacular building throughout the world. However, for the purpose of this research we will forgo a lengthy historiography of ancient indigenous construction techniques and ingenuity, and we will direct our attention to the twentieth century. We will attempt to address only those most significant happenings and trajectories within the last century that have had serious, and to some extent lasting, influence upon sustainable technologies and the discipline of architecture and construction.

Since the advent of the Modern Movement a century ago there has been a lineage, a sporadic continuum, of architects and craftsman who have considered it not only important, but also essential, that architecture relate to its environment and its occupants in a responsible manner. There have been those of imagination and creativity who have contributed, in one form or another, to the development of environmentally conscious building techniques through technological advancement and simple, lucid intelligence. Within this brief discussion of those who have made contributions to the evolution of sustainability, we make a distinction between two categories of architects. The pure problem-solvers and those who create solutions within greater design vision.

There have been those of extreme position and scientific persuasion, like Buckminster Fuller, who advocated a purely engineering-based approach to solve the difficult dilemmas facing architecture relating to environmental sensitivity and energy efficiency. Fuller, his followers, and others who fall into this pedigree of designer/problem-solver have a most decidedly utopian edge to their idealistic solutions and theoretical positions. This assessment of Fuller and those like him, being overly idealistic takes nothing away from their noble intentions and contributions to the disciplines of architecture, engineering,

and the beginnings of sustainability. However, there is a second collection of architects that also made significant contributions to the advancement of sustainability.

This group of enlightened individuals includes the Keck brothers and Paul Rudolph for example. These men sought a logical balance between environmental responsibility and serious architectural design propositions. We will primarily focus on this latter group of architects and establish them as the venerable predecessors of a contemporary movement within the discipline of architecture that is concerned with the environmental responsibility of architecture.

Let us begin our discussion with the notable designer-engineer, Buckminster Fuller. For the purpose of our discussion it will prove invaluable to gain an understanding of Fuller's significant works. Even a superficial appreciation of his research and ideological positions regarding structure, technology, and the environment will provide an important context when considering his contributions to the evolution of sustainability.

Fuller was, undoubtedly, ahead of his time. Trained as an engineer, though never officially graduating from Harvard, Fuller was a scientist, innovator, and inventor with an idealistic vision to transform the world into something better. His exploits and accomplishments have been well chronicled over the last seven decades and have had a profound effect upon design, engineering and architecture of the twentieth century.

In the late 1920's and 1930's, Fuller's experimental Dymaxion designs for cars, bathrooms, mobile dormitories, and homes were influential in establishing him as an innovative and visionary designer. These designs were the manifestation of Fuller's belief in the purity of mass production and efficiency. Throughout his career he was a major crusader against the nineteenth century practice of handcraft construction and manufacturing. Fuller believed that only through standardization, mechanization and technology could mankind solve its impending problems, including the emerging issues with housing. Although, ultimately none of Fuller's Dymaxion series designs found a mass

audience or implementation, they were a central part in the history of mid-twentieth century design thinking and theory that inspired generations of designers toward a new horizon.

Buckminster Fuller was also a prolific writer and theoretician. Some of Fuller's highly theoretical projects, like Cloud Nine, were influential in inspiring entire movements of the 1960's. Groups like The Italian Radicals and Archigram founded much of their work upon Fuller's theoretical, futuristic and highly unrealistic ideas about the imminence of architecture becoming a network of systems and infrastructure on a massive scale.

Buckminster Fuller is probably best known for his kit-of-parts geodesic domes. The most notable of these, obviously, is his design for the United States pavilion at the 1967 World Exposition in Montreal. This project for Fuller was a culmination of decades of research of structures, geometries and materials. Throughout the years of research that Fuller invested in the scientific study of domes, he also theorized many uses for them. From small scale camping tents, to single-family eco-houses, to theoretical mega structures that would enclose much of Manhattan.

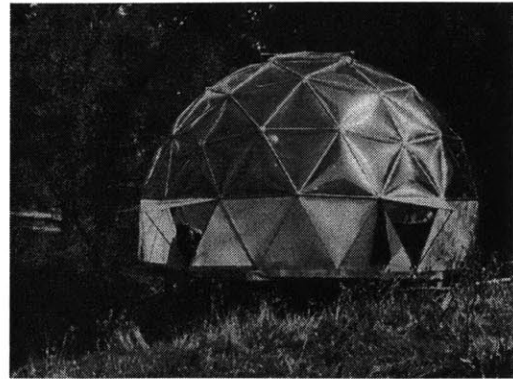

Geodesic Dome, Buckminster Fuller, 1940.

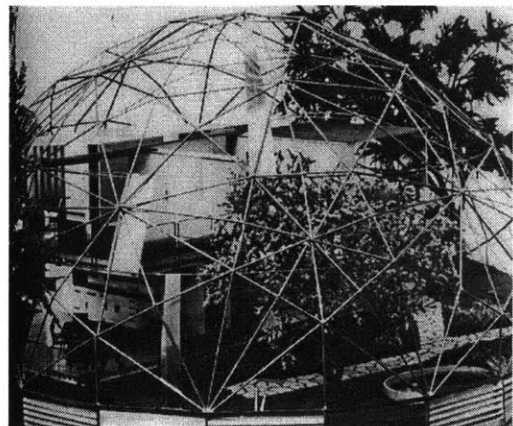

Dymaxion House, Buckminster Fuller, 1940.

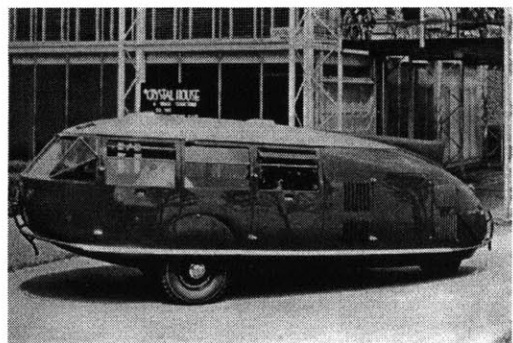

Dymaxion Car, Buckminster Fuller, 1935.

What is most significant to our discussion is Fuller's contribution to the beginnings of what would eventually be the sustainability movement. As early as the 1940's Fuller hypothesized the possibilities of private homes becoming completely environmentally efficient and renewable. Fuller's design for his Eco-Houses consisted of easily constructed, pre-fabricated homes covered with glass geodesic dome structures. The fundamental idea of Fuller's Eco-House proposals was that with enough vegetation and proper maintenance, these homes would be self-supporting microclimates requiring no mechanical heating or cooling. Also, within the perimeter of the dome, occupants would eventually, be able to grow their own food, filter and redistribute waste and water. These homes would literally be sustainable, renewable microenvironments with limited impact on the environment and require limited resources to produce. For decades, the key concepts that Fuller was working with were widely unknown, he was thinking of single-family homes as ecosystems, trapping sunlight, recycling waste, and taking minimum toll of irreclaimable resources (Kenner 202).

Ultimately, these homes remained unfulfilled ambitions. The problems, both practically

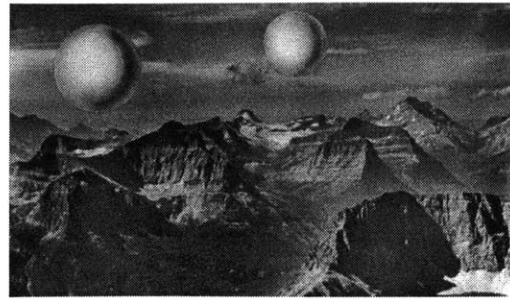

Cloud Nine, Buckminster Fuller, 1960.

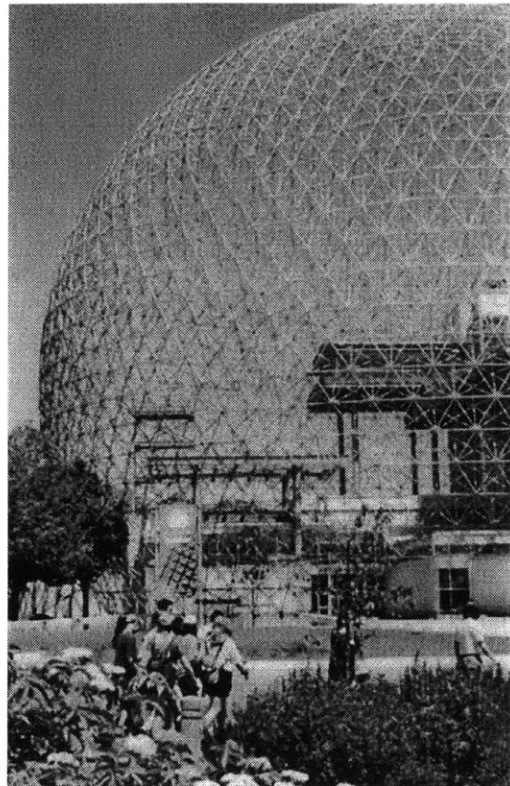

1967 World Expo, U.S. Pavilion, Buckminster Fuller.

and theoretically, were insurmountable. The one case study actually built, Climatron, constructed in St. Louis Missouri in 1960 proved that the reality of the project, and the theoretical vision were two different things. Climatron was never able to achieve comfortable, or even livable, climatic conditions. It also was unable to be constructed or maintained as inexpensively and easily as hoped. While still in existence, Climatron is now a monument to Fullers utopian vision of the future of the built environment coexisting with nature in a benign and responsible manner.

Although Fuller's Eco-House vision was never fulfilled, and Climatron proved unsuccessful, what is important are the ideas that survived and continued forward. Although the passive solar movement of the 1970's evolved due to many factors, it took much of its inspiration from Fuller's research and ideas regarding passive solar efficiency and renewable resources. Like Fuller's Eco-Houses, much of the work associated with the passive solar movement of the 1970's also proved unsuccessful for various reasons. This was due mainly to the fact that the projects were highly experimental and often quite radical. The experimental nature



Climatron, Buckminster Fuller, 1960.

of the work, did however, produce some fascinating case studies.

One cannot address the sustainability movement of the 1970's without addressing the oil embargo and its effects on energy consumption and consciousness in the United States. The embargo which took place in 1973-1974, technically, only lasted six months, however its effects were felt for decades.

By the beginning of the 1970's, an environmental awareness movement had already gained significant momentum in the United States. While it remained on the periphery of popular culture and mainstream America, environmental concerns were gaining popularity. The growth of the movement during the 1960's was in part due to many of the radical protests of that era, which questioned both the establishment and recent trends in American society. While much of the protest and spotlight was directed on civil rights and the Vietnam War, some attention was being paid to concerns for the natural environment and the adverse effects of heavy industry and consumer consumption.

While the energy crisis on the 1970's cannot be reduced to one specific reason or event, one can postulate that the catalyst for the crisis was the oil embargo of 1973. Many experts in the field believe that the actual energy crisis was caused more from the United States' own extreme consumption patterns and poor energy policies than from a six month long embargo. At that time the United States was receiving 36% of its oil from the Middle East, an amount that many feel could have been supplanted from other sources in other regions of the world, had the United States embraced a comprehensive energy policy. This however, was not the case.

Because of long standing religious and political conflict, many Middle Eastern nations cut off exports of petroleum to many Western nations including the United States in anger over the Arab-Israeli conflicts. With the commencement of the oil embargo of 1973, energy concerns that were once at the margin of American consciousness, became dominant, front-page issues. Within a three month span, the price of a barrel of oil increased by 130%. This dramatic increase in oil prices triggered a huge rise in the price

of both gasoline and home heating oil. These severe increases brought widespread panic to the nation at large. The resounding impact in the United States of this embargo was compounded by high consumption patterns and a panic-stricken market.

The problem of high consumption was a major issue that emerged from the oil crisis. Only after this scare did the United States government and the American public begin serious efforts to curb its high consumption rates. The total United States consumption of imported oil declined significantly in the late 1970's and early 1980's following the crisis. High oil prices prompted consumers to conserve energy and switch to other forms of fuel. This is an important fact regarding our discussion of the passive solar movement in architecture of the 1970's.

Whereas the Middle East oil embargo was a catalyst for the energy crisis of the early 1970's, the energy crisis was a catalyst for alternate forms of energy and environmentally conscious movements of the late 1970's and early 1980's. The passive solar movement in architecture cannot be entirely attributed to the energy crisis, but it certainly was one of the leading factors that stimulated it, and provoked much research and exploration.

Much of the research pursued within the passive solar movement was quite radical in nature. However, as stated earlier, much of this radical experimentation produced some fascinating case studies, and succeeded in furthering the discipline toward environmental responsibility. An excellent example of extreme, passive solar experimentation is the Baer House near Albuquerque, New Mexico built in 1972. This project incorporated a system called the Drumwall. In this system, steel oil drums are filled with water and stacked in vertical racks inside of a glass window wall. The drums, painted black on the end that faces the sun, absorb solar heat and then release it slowly into the interior after the sun goes down (Watson 35). Operable insulating panels on the exterior side of the water filled drums control excessive heat gain in summer months. Obviously, this passive system had many complications and proved only marginally effective.

Another of these experimental systems was called the Roof Pond System. Designed and patented as the Skytherm System by Harold Hay, it was demonstrated as experimental installations in Arizona (1967), and California (1973). In the Skytherm design, the solar collector-storage element is a water-filled clear plastic bag, 8 inches thick, placed on a flat roof of a dwelling. Moveable insulated panels are positioned on tracks above the water bags for insulation during cold winter nights. During sunny days the panels are opened to expose the water bags to the sun's heat. Warmed during the day, the heat radiates downward through the metal roof deck to warm the building interior below (Watson 39). The System proved somewhat effective, but still required mechanical conditioning as a supplement. This complicated and fragile system failed to achieve an audience beyond a limited number of experimental homes.

The Baer Residence and the Skytherm System are but two examples of a myriad of experimental passive solar systems that were designed to capture the radiant heat of the sun, and store it in liquid form. Most achieved similar mediocre results as the Baer Residence and Skytherm System. Beyond the passive systems designed to capture and

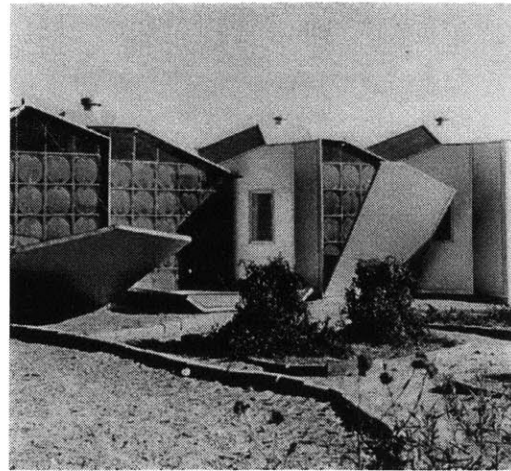

Baer House, Albuquerque, 1972.



Baer House, Albuquerque, 1972.

store radiant heat, many active systems were developed as well. Many of these systems relied upon energy generated by wind or solar collectors that was then used to power semi-conventional environmental control systems. For the purpose of this discussion, it is unnecessary to elaborate in further detail upon the technical aspects of these systems. However, more information regarding various passive and active systems developed in the 1970's, appears in Donald Watson's *Designing and Building a Solar House: Your Place in the Sun* (1977) or *Survey of Passive Solar Buildings* (1978) by AIA Research Corporation.

Formal aspects of passive solar architecture performed a significant role in passive solar design in the 1970's. Many designers of the day attempted to rethink all formal and aesthetic presuppositions of residential architecture. By focusing on efficiency and challenging well-established formal and stylistic norms, designers stepped outside the architectural mainstream. One of the more conspicuous design elements of passive solar aesthetics was an emphasis on the roof. Primarily concerned with solar collection and storage, designs typically relied upon large, sloping roofs that afforded huge surface areas for solar collectors. These roofs,

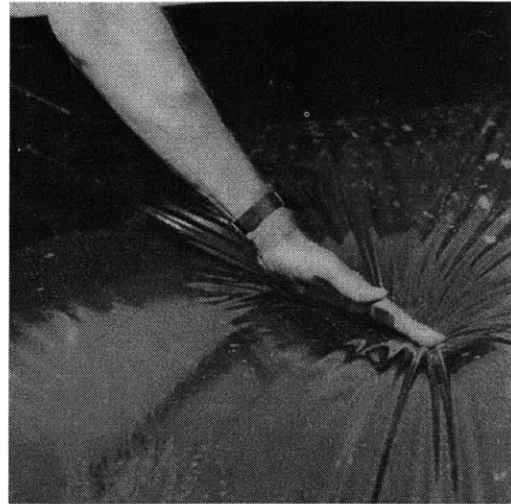

Roof Pond System, Skytherm, 1967.

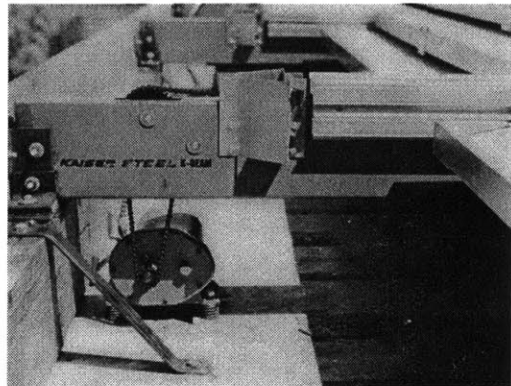

Roof Pond System, Skytherm, 1967.

inevitably, became formal elements within the overall construct.

Along with the experimental technologies and dominant roof elements already mentioned, there were other design considerations that affected the formal and aesthetic quality of these designs. Most of these passive solar houses were exceedingly sensitive to proper orientation, experimental materials, and of course, climatic conditions and variations. This, in itself is in no way a negative occurrence. However, by directing their attention completely to energy efficiency and experimental technologies, many of these designers of passive solar homes ignored issues fundamental to architecture that afford a pursuit of serious architectural propositions. By relegating all architectural concerns subordinate to passive solar innovation, these homes became mere novelties. Most people, designers and the public alike, became disinterested and disenchanted with the idea of passive solar technologies in architecture. Consequently, the hundreds of experimental houses produced never fulfilled their prophecy of solving the world's energy problems through ubiquitous use.

Although much of the experimental work of this era proved marginally or completely ineffective, we must not discount the advancement made. Knowledge critical to the development of future environmentally responsible control systems was achieved through rigorous research and many failed attempts. The fundamental ideas of the passive solar designers and researchers of this era were noble; the execution was somewhat misguided. This misguided execution of significant ideas appeared to the outside world as extremism. The extreme nature with which they pursued their projects and research would, ultimately, prove counter-productive to their goal of architectural sustainability.

We have briefly discussed the lineage of twentieth century sustainability from Buckminster Fuller through the passive solar movement of the 1970's. This discussion was primarily concerned with those who viewed the development of sustainability as an engineering or scientific discipline. However, there is an alternate trajectory that one may trace through this era. From the 1930's through the 1950's a handful of architects concerned themselves with the fundamental ideas of sustainability and energy efficient

design. Paul Rudolph and Fred Keck, quietly experimented with passive solar techniques, and sustainable technologies in their respective works. The Keck brothers and Paul Rudolph must be recognized as significant, as pioneers, in the evolution of sustainability because they did something that Fuller and the extremist of the 1970's did not. They included sustainable practice into their designs as only one participatory element within a larger architectural vision.

When, in the 1930's Fred and William Keck began experimenting with passive solar heating systems in their designs, the International Style, more specifically Mies van der Rohe, had emerged as preeminent in the world of architecture and high design. The Keck brothers were undoubtedly Modernist, and believed strongly in the ideology of the new style. They were however, a departure from most other Modernist of the time. They did not adhere to the notion of the sealed glass box that Mies and Walter Gropius had made so famous. The Keck brothers were interested in a more practical approach to building and construction. They believed that energy efficiency was an important facet of the modern world and the future of architecture. Aesthetics, style and energy efficiency could coexist within the Modern para-

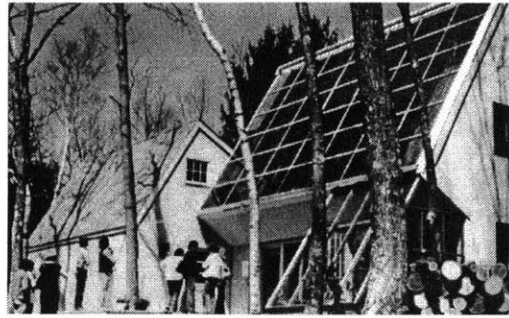

Goosebrook House, New Hampshire, 1977.

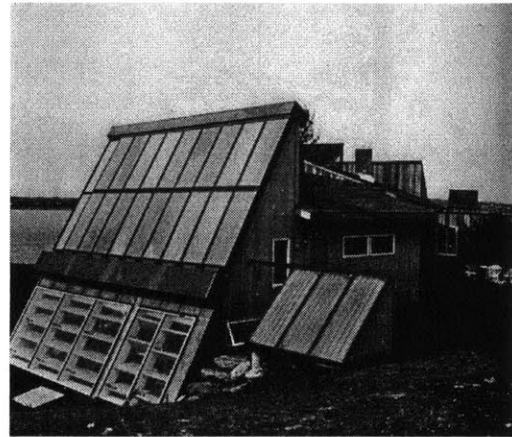

Eddy House, Rhode Island, 1976.

digm. This belief produced a series of Modernist houses and buildings in the 1930's and 1940's that pioneered environmentally responsible modern design. Although largely unrecognized, in their own time, for their energy consciousness and contribution to the future of sustainability, the Keck brothers would gain widespread recognition for their clean Modernist aesthetic throughout their careers.

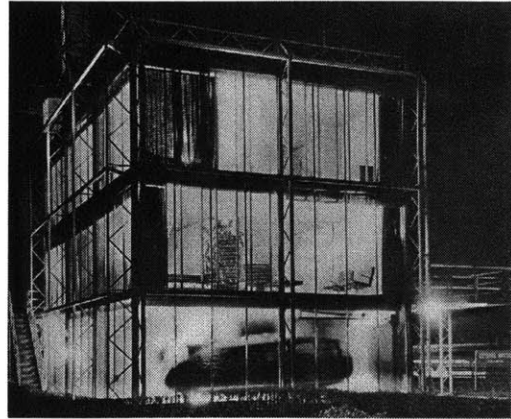

Crystal House, Keck & Keck Architects, 1934.

The Crystal House was built in 1934 for the Century of Progress Exhibition in Chicago. This three-story project, enclosed mostly with glass, was supported by a delicate truss-like system of steel columns and trusses. This structural system afforded great flexibility resembling the work of Mies van der Rohe (Menocal 15). The importance of the Crystal House however, does not reside in the fact that it formally or aesthetically resembled the work of Mies. The significance is that it was an early and convincing example of how a well-designed, Modernist building could use the sun to heat it during the day without additional mechanical heating. An overhang over the glass was dimensioned to shade against overheating in summer. Masonry surfaces were located on the interior, in the fireplace wall, and the floor to help absorb the heat on sunny days and

carry some heating effect into the evening (Watson 55). These straightforward passive solar strategies appear obvious to most of us today, seventy years later. However, in 1934 many of these simple, but effective techniques, had never been used or explored in early Modernist architecture.

The Keck brothers did not only use passive solar techniques in Exhibition designs. These strategies became a consistent part of their residential design for decades. One of the Keck's earliest passive solar private residences was the Herbert Burning House in Wilmette, Illinois 1935. In this project the Keck's used many passive strategies that would become standard practice in many other projects. This project paid particular close attention to sun angles, orientation of the house, overhangs, thermal massing and natural shade. The Keck's also improved the design of their windows by introducing external aluminum Venetian blinds. These allowed for bright or totally dark rooms, replaced storm windows in the winter, regulated the flow of air coming into the room in the summer, and rendered draperies unnecessary (Menocal 19).

George and Fred Keck were not only architects working within the Modernist archetype that were concerned with sustainable practices. Paul Rudolph working in Florida from the mid 1940's to the early 1960's produced a series of extraordinarily elegant beach homes that effortlessly incorporated passive solar techniques into the designs. He created striking Modern buildings that had the unique characteristics of a particular place.

Rudolph's work in Florida explored the idea that modern architecture, more specifically, the International Style, could be sensitive to regional expression. Departing from Modernist doctrine of the period, Rudolph attempted to make an intimate connection to the landscape by using indigenous materials, local construction techniques when applicable, and made reference to vernacular expression. Rudolph's regionalism became his vehicle for inserting specific notions of place and cultural context into the vocabulary of contemporary architecture (Domin 139). Because of this unique interpretation on the International Style, he produced some remarkable work that brought him international recognition.

The Healy Guest House of 1950 in Siesta Key, Florida was one of Rudolph's early masterpieces that incorporated environmental sensibilities. Also known as the Cocoon House, this design with its simple geometric volumes of space, was a highly rationalist design and a strong modernist aesthetic. This project, however, clearly was much more than a convincing modernist project. The entire work is a case study of early environmental sensibility and regionalist modern architecture.

Great importance was given to climatic considerations throughout this project. Cross ventilation strategies were a significant design factor. Louvers designed to block the sun, while still allowing air to cross ventilate the interior space were a considerable feature within the project. In fact, entire walls were constructed of specially designed louvers that allowed them to be adjusted from completely open to entirely opaque. Also, the structure was elevated just slightly off the ground to help capture prevailing breezes coming off the water. Exterior overhangs were placed at appropriate elevations to combat afternoon heat gain. With all the simple, yet intelligent, low-tech strategies incorporated within the project, these environmentally sensitive features were just one



Burning House,
Keck & Keck Architects, 1935.

aspect of the experimental nature of this house.

The Healy Guest House is also an experiment in structure and technology. Steel straps were used to span between sidewalls to hold up the roof and to create its curved catenary shape. The roof structure is an original technological assembly: the steel straps were fastened to flexible insulation boards and the roofing material is sprayed on. This flexible vinyl compound was developed by the U.S. military and was used to encase ship components to protect them from weather (Domin 97). The experimental use of a new material and rather innovative structural system adds another layer of complexity to this project.

One can compare the Healy Guest House with two other important houses built approximately the same year (circa 1950). The Farnsworth House by Mies van der Rohe and Philip Johnson's Glass House are two canonic Modern works famous throughout the world. These projects undoubtedly made significant contributions to the Modern movement. One may draw some parallels between the Farnsworth House, the Glass House, and Rudolph's Healy Guest House. Much of the significance of the Farnsworth

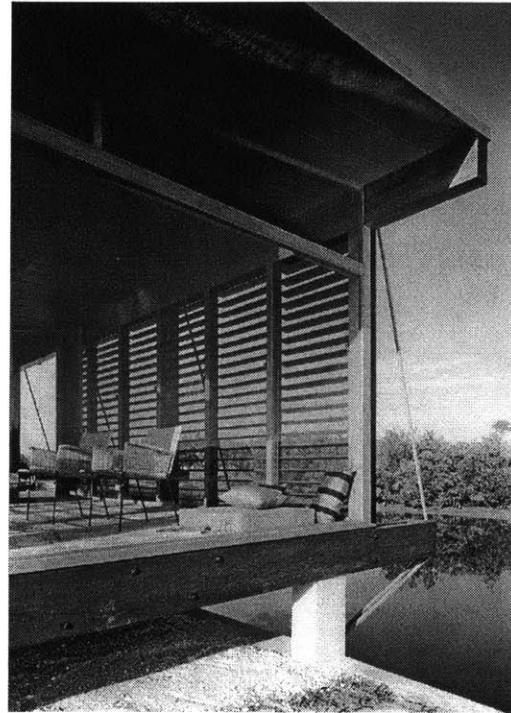

Healy House, Paul Rudolph, 1950.

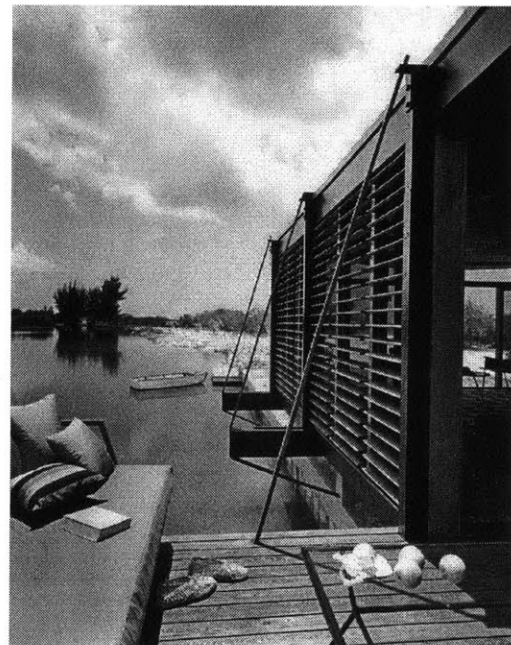

Healy House, Paul Rudolph, 1950.

and the Glass House relies upon their transparent disposition in the landscape. Their radical concept of complete openness affords observation of the surroundings. However, this experience remains primarily visual. The Healy House, by comparison, engages the full sensory experience of the site and landscape. The breezes, sounds and smells of the immediate environment become part of the experience of the house, creating an extraordinary sense of place. Additionally, unlike the Mies and Johnson projects, the experience of the surroundings can be modified from the interior by adjusting the walls. The intense connection to the environment and climate provide the Healy House with supplementary physical and metaphysical depth. What is exceptional about this project is the fact that Rudolph explored a connection with the environment and regional cultural expression, while working within the austere early modernist paradigm.

The Healy Guest House is but one example of many projects by Paul Rudolph that explore the connection between architecture and sensitivity to the environment and cultural context. Rudolph pioneered such work throughout the 1940's and 1950's. Unfortunately, many of these low-tech experimental devices Rudolph utilized to connect his houses with climate and culture were abandoned for a mediated, controlled interior environment with the advent of ubiquitous air-conditioning.

This concise discussion of the evolution of sustainability in the twentieth century is in no way intended to be a comprehensive survey. The intention here is simply to provide a context for further discussion about the state of contemporary architecture with its growing emphasis on sustainability. By tracing two alternate, yet simultaneous, trajectories through the history of sustainability, we are able to gain perspective of those successes and failures that have brought the movement and study to where it is today. By locating specific moments in time, events, or projects that are relevant to today's situation, we are better able to postulate the future of architecture and sustainability.

Although the ambitions of Buckminster Fuller and the passive solar advocates of the 1970's were never realized, we can certainly learn from both their innovative research and case studies. The scientific knowledge produced by these imaginative thinkers has

been the foundation of countless sustainable technological innovations over the last forty years. However, we must also take careful consideration of their failure to gain widespread appreciation due to extremist tendencies. The advancement of sustainability must be incorporated with, not dominant over, architectural vision.

The influential work of the Keck brothers, Paul Rudolph and others like them is exceptional in that it endeavored to incorporate sustainable practices into larger design considerations. This very fact is what makes their work still relevant today. Current architects and scholars would be well advised to rediscover the work of these men and learn from their simple, yet elegant and inspired ideas regarding the synthesis between architecture and its environment. Norman Foster, Renzo Piano, and Glenn Murcutt for example, throughout their distinguished careers have followed a similar trajectory as that of Rudolph and the Keck brothers. They are the direct beneficiaries of the groundwork laid by these designers. We will discuss more closely the work of contemporary architects like Norman Foster to gain an understanding of their influence upon the discipline of architecture and sustainable concerns. We will also examine those more recent subscribers to the practice of environmentally sensitive building, like Richard Meier, who after extraordinarily successful careers as high-design architects, have now found it important to incorporate sustainability issues into their work. The influence of both of these types of architects will be pivotal to our discussion of an environmental consciousness emerging within the architectural mainstream.

Chapter 3
Norman Foster: Leading the Way

When attempting to locate the recent movement or shift within the discipline of architecture toward a new horizon of environmental consciousness, it is fundamentally important to study those architects who have consistently been ahead of the curve; those who have been the most innovative, the most creative in the use of emerging technologies and materials in concert with design considerations. In the anticipation of future concerns for natural and non-renewable resources, Norman Foster has been on the leading edge of design. Before the energy crisis of the 1970's and well after the energy conscious dialectic had faded, Foster experimented with and produced energy efficient buildings.

Norman Foster has been an advocate of environmentally responsible, energy efficient design since the inception of his career over thirty years ago. Once categorized as "High Tech" for his design aesthetic, Foster has consistently proved that his interest in emerging technology goes well beyond the visual. Within the last decade Foster Associates have emerged as one of the premier design oriented, technologically advanced and environmentally sensitive firms in the world. What has afforded them the opportunity to evolve in this way is their innate belief that architecture and technology are not mutually exclusive. They are to be pursued in concert to achieve the most appropriate solution and design for any given problem. This attitude toward architecture is certainly not avant-garde or extraordinary in any way. Architects for centuries have pursued technological advancement through their work. What is extraordinary however, is the extent to which Foster Associates have realized this connection between architecture and technology and the effect that their work has had on the discipline itself.

There is a relatively small group of architects that we may look to as standard-bearers within the discipline who have spent their careers exploring a synthesis between design, technology and the resultant benefits. This group includes architects such as Renzo

Piano, Nicholas Grimshaw, Thomas Herzog and of course, the focus of this chapter, Norman Foster. We label this group as standard-bearers because they have been the leading advocates for many years of issues and concerns that the rest of the industry is only recently beginning to regard as necessary. While these architects were somewhat on the periphery of the discipline for decades exploring topics of energy efficiency and sustainable technologies, they are not alone in their interests and pursuits any longer. Many architects have, recently, begun investigating and implementing similar design strategies regarding environmentally responsible buildings. We will explore some of these more recent additions at a later time. For this chapter however, we will primarily direct our attention to Norman Foster and the evolution of his work over the last thirty years. For this discussion, Foster will serve as representative of the select group of architects who have explored sustainable technologies throughout their careers. We will examine closely some of Foster's earliest work to gain an understanding of the technologies and strategies he has continuously attempted to implement and improve upon for decades. By comparing these with one of his most recent and celebrated projects, The Reichstag Parliament Building in Berlin, we may achieve an understanding of the importance of Foster and his work as a standard-bearer within the discipline of architecture.

In an essay written in 1979 the famed architectural theorist and critic Reyner Banham made the argument that Norman Foster does not implement high-technology in his buildings, he uses appropriate-technology. This is an important distinction and one that needs to be explored further. Because much of Foster's early work consisted of lightweight materials that were usually associated with high-technology, Foster was unfairly categorized as using a High-Tech aesthetic regardless of cost or effectiveness. This Banham contends could not be farther from reality. Foster has always tried to use the materials and strategies appropriate for any given project. For example, the various IBM buildings designed by Foster are extremely high energy use buildings. Considering the extreme energy requirements of these buildings, at the time of construction, sustainable technology was insufficient to have any noticeable effect. Therefore resources were not expended on such technologies. However, for other projects like the Sainsbury Centre

for the Arts, built around a similar time period, Foster was able to explore relatively light servicing strategies being that the building had modest energy requirements.

Foster has never put stylistic considerations ahead of what he felt was the appropriate technological response to a given program. This has been a problem for critics. They have found it difficult to accurately categorize Foster's work. Unlike other architects who have been categorized as High-Tech, Foster has never gone out of his way to evolve an architectural style or an iconography of detail that is unequivocally High-Tech. Reyner Banham put it quite eloquently when he said "There is no single Foster style, though the range of stylishness is close and connected. But none of the styles in the range specifically labels a particular type or quantity of servicing, and this makes life very difficult for the average hit-and-run journalist, or lecturer playing solitaire with a hundred slides in the AA library. The rock-bottom, bottom line fact about Foster Associates is that you can't tell just by looking; you have to go inside" (Banham 5).

Although Norman Foster does not subscribe to a particular style or aesthetic in this work, he continuously uses new materials, cutting edge structural techniques, experimental enclosure systems and innovative tectonic connections. All these elements he utilizes concurrently to create ecologically friendly buildings. Therefore the most recent categorization of Eco-Tech is probably one that is rather appropriate. His work does certainly synthesize emerging technologies with ecological concerns. This new categorization is only important in that it distinguishes between Foster and many of his contemporaries like Richard Rogers or Jean Nouvel. These architects, and many like them, are more concerned with the superficial appearance of technology than they are in buildings that actually utilize technology toward specific purposes. They use a technological aesthetic in their architecture. However, when inspected more thoroughly, much of their work is technologically quite average. Whether one chooses to categorize Norman Foster as High-Tech, Eco-Tech, or Reyner Banham's Appropriate-Tech is insignificant. The importance resides in the work itself. Foster has for three decades produced buildings with a higher purpose than simple empty rhetoric or formal metaphor. His belief in the logical synthesis of architecture and technology to achieve ecologically responsible

buildings has recently emerged as a serious and ubiquitous trend within the discipline of architecture and one that many architects are beginning to pursue.

The Willis Faber and Dumas Head Office in Ipswich (1975) is one of Foster's early influential projects. Built in the historic district of what was a rather sleepy country community, The Willis Faber building had great impact on the town of Ipswich. Initially received with contempt and skepticism, it has quickly become not only revered but imitated throughout the world.

This building is Norman Foster's most traditionally formal Modernist project, though there is much innovation as well. There is a clear lineage with Le Corbusier and his austere International Style. Two of the most obvious early modernist references are the open-plan dissolve of conventional interior space, and also the displacement of the typical atrium, which is basically a static space (although it may accommodate movement), by creating a totally kinetic experience through the thrust of escalators (reference the Villa Savoye) (Quantrill 82). The planning and arrangement of the interior of the building as well as the hung-glass cladding of the perimeter all make strong reference



Willis Faber Building, Ipswich, 1975.

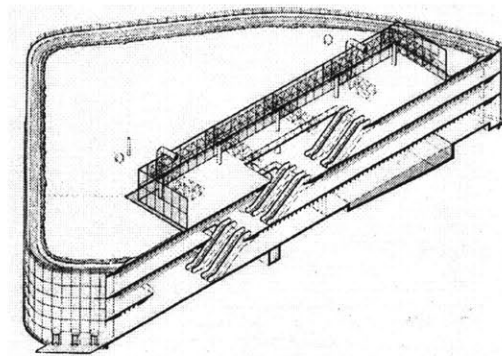

Willis Faber Building: Axonometric, 1975.



Willis Faber Building: Roof Garden, 1975.

to Le Corbusier. The most celebrated early modern idiom of the Willis Faber building is the roof garden. This design feature has become one of the most popular characteristics and most frequently used areas of the building.

Apart from the Modernist references, the Willis Faber building was a highly innovative project for its time. These innovations are what will be most pertinent to our discussion. First let us re-address the roof garden. Although, championed in the early 1930's by Le Corbusier and his followers, the roof garden never achieved widespread use. It forever remained a theoretical concept for early Modernist and Futurist. Foster incorporated the roof garden into the Willis Faber building with a multitude of purposes in mind. Aside from the fact that the occupants of the building enjoy the outdoor green space and use it frequently for everything from lunch breaks to sun bathing, the garden roof itself provides tremendous insulation from temperature fluctuation. The consequence of this is a rather significant reduction of heating and cooling costs. The Willis Faber building, on average, has rather typical energy consumption patterns. It is neither sensationally high, nor sensationally low. However, considering the amount of glass on the façade of this edifice, and the intense use of the interior space, one would expect high energy consumption. Also, the roof garden is such a good insulating quilt for the structure that expansion joints, typically used in buildings of similar scale and construction, were unnecessary. It is important to note that Foster used a non-traditional design feature like a roof garden as not only a wonderful space for the occupants, but also as a functional environmental passive system to enhance energy efficiency. Also, Foster anticipated the oil crisis of the mid to late 1970's by using natural gas as the primary fuel source of the building.

The structure of the Willis Faber building can be boiled down to remarkably few elements: a set of internal columns, a cantilevered slab, and a set of edge-columns. What is significant though, is that this relatively basic structural layout and cantilevered floor slab allow the facade to materialize. The curved glass curtain-wall façade is clearly the most important design feature of the Willis Faber project. The curved glass façade, of course, could be likened back to Mies van der Rohe's designs for glass skyscrapers in

Berlin. The difference is that, the Mies projects were purely theoretical. The dream of a pure, uninterrupted glass wall without supports was for Mies, just that, only a dream. The Willis Faber building, however, comes very close to making that dream a reality. Foster achieves this reality of an all glass façade without mullions by introducing a revolutionary wall system that was experimental at the time of construction.

The tectonic system that Foster Associates developed for the glass curtain wall, unlike most experimental systems, is in all actuality, highly efficient. It is nothing more than glass and glue. A clamp bar at the top of the structure is used to hang the glass in tension. At each corner of intersection between four sheets of glass, a patch plate is used to secure them together. A simple translucent sealant between each piece of glass is applied to stabilize and fasten. The result of this technique is the appearance of a continuous wall of glass unbroken by mullion or structure.

While the Willis Faber building has been the topic of countless discussions and research papers, for our purposes, we will refrain from expanding our analysis of it. What is important to note about this project is that Fos-

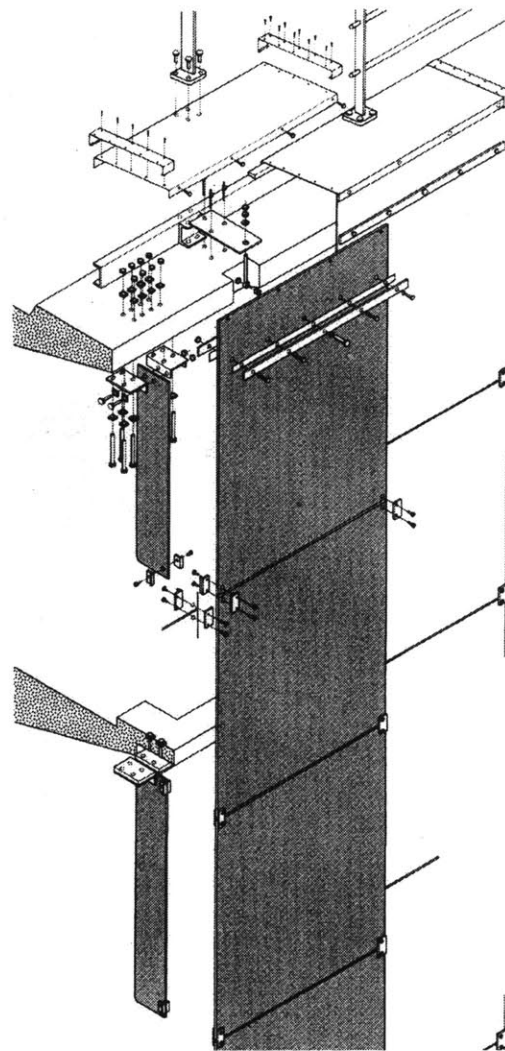

Willis Faber Building:
Suspended Glazing System, 1975.

ter, early in his career, was searching for ways to innovate and experiment with technology, be it high or low-tech, to create architecture and enhance design. Also, it is important to note that the Willis Faber project is an early example of Foster Associates experimenting with passive sustainable technologies such as the roof garden to improve energy efficiency. While this project is only moderately sustainable, Foster will gradually become more and more interested in the idea of utilizing technology toward sustainable purposes. Therefore, the Willis Faber building is a significant threshold in Foster's career. It marks the beginning of his evolution toward a synthesis of sustainability and design expression.

The Sainsbury Centre for the Visual Arts in Norwich, UK (1974-78) is another early Foster project that is rooted in technological experimentation and concern for energy efficiency. This, most decidedly, atypical art gallery utilizes many interesting structural and energy strategies. The basic structure of the building is welded tube steel, which is clearly expressed on both ends of the building. The tube-steel, space-frame system spans 110 feet and provides an entirely column-free, unencumbered space on the interior. This open-ended form of the build-



Sainsbury Centre, 1978.

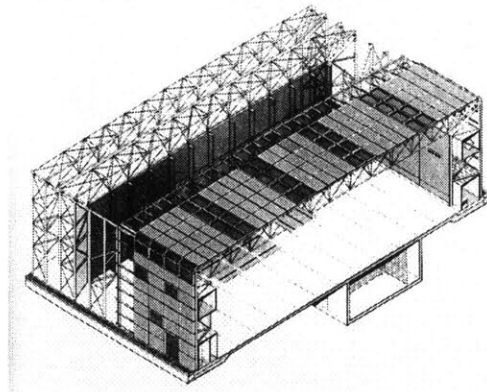

Sainsbury Centre: Superstructure, 1978.

ing allows clear views through the length of the space. The two clear glass walls on either end of the edifice are designed for maximum visual and day lighting effect. These walls utilize full height glass panels connected only by a clear adhesive; similar to those of the Willis Faber building.

The inner skin of the walls and the roof lining of outer panels contain between them the structure of the building. This 8-foot thick wall-system, housing the structure, also accommodates a wide collection of fixed, utility functions as well. These functions contained neatly within the wall include the lobbies, restrooms, photography studio, storage, shops, and all mechanical and electrical systems. Also, all circulation can take place within these walls, isolated from the gallery if needed. Within the roof zone, which also has a depth of approximately 8 feet, the lighting can be accessed, maintained and (re)directed as needed without disturbing the exhibits below.

The exterior panels enclosing the structure were specially developed for this project. There are three types of panels used; glass, solid, and gridded. They are all interchangeable with one another by simply unbolting them and removing or replacing. The entire

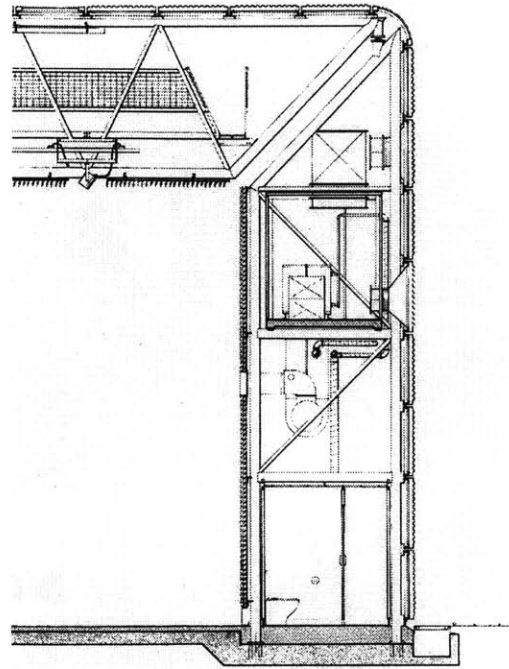

Sainsbury Centre: Wall Section, 1978.

process of removing and replacing a panel takes approximately five minutes. The panels themselves are constructed of a foam-filled, highly reflective anodized aluminum surface. While the outer aluminum surface reflects heat, the foam within the panels have an exceptionally high insulation value. The panels themselves are sealed with neoprene gaskets which double as rainwater channels, thus obviating the use of traditional gutters (Abel 126). The inner skin of the structure consists of adjustable aluminum louvers with additional motorized banks under the glazed areas. These, combined with the interchangeable external panels and a highly flexible system of electric display lighting, produce an almost infinitely adjustable natural light control system.

Sainsbury Centre is a prime example of Foster Associates implementing technologies for the purpose of energy efficient design. From the nature of its prefabricated materials, to the enclosing walls with its double thickness, reflectivity, insulation value, combined with the engineering of air movement through the space as an alternative to air conditioning, Sainsbury Centre is a light-weight, low impact, low energy consumption building. Completed three years after the Willis Faber building, Sainsbury is another stride along Foster's trajectory of ecologically sensitive and responsible architecture that will eventually define his career. Reyner Banham appreciated the subtleties of the design and the craft of the construction of the Sainsbury Centre so much that he wrote of it "If 'appropriate technology' is to be Foster Associates slogan, than Sainsbury will certainly be the example by which that slogan is measured".

These last two projects we have looked at, the Willis Faber building and Sainsbury Centre, provide us with a good understanding of Foster's intentions early in his career. While obviously interested in emerging technologies and their impact on architecture, he also had a deep concern for how the built environment impacted nature and how technology could be used to limit the consumption of non-renewable resources. While Foster consistently worked with these issues throughout his career, the next project we will address, the Reichstag, will provide an understanding as to the extent of sophistication and advanced nature of the work of Foster Associates.

The new German Parliament building, The Reichstag, in Berlin recently completed in 2000, is thus far the pinnacle of Foster's evolution in the realm of sustainable technologies and high design. While not a new construction, the Reichstag project was possibly one of the most high profile renovation projects in history. The German Reichstag is a nineteenth century building littered with history, memory and trauma. Any renovation of this building would need to account for the fact that it is as much a museum and monument to Germany's turbulent history of the last century, as it is a place of government and democracy. Also, with an ambitious ecological agenda laid out by the German government, Foster Associates had a colossal task ahead of them. What was produced in the end was truly extraordinary.

A brief history of the Reichstag is important to understanding the sensitive nature of this project. Interestingly enough, when first constructed in 1894, the Reichstag was technologically quite advanced for its time. It utilized a ventilation strategy built into its massive walls that would prove invaluable to Foster Associates when they renovated the structure more than a hundred years later.

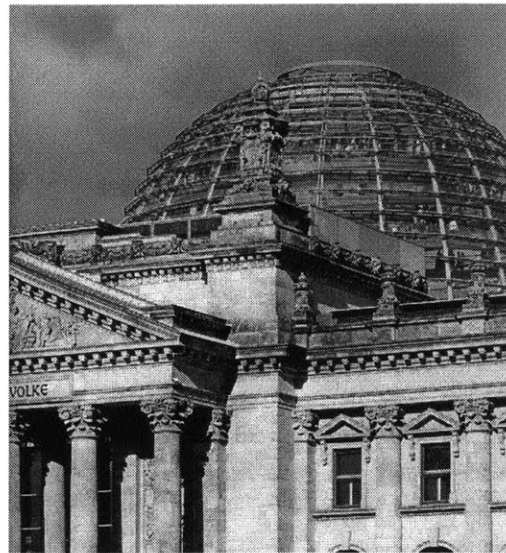

The Reichstag, Berlin, 2000.

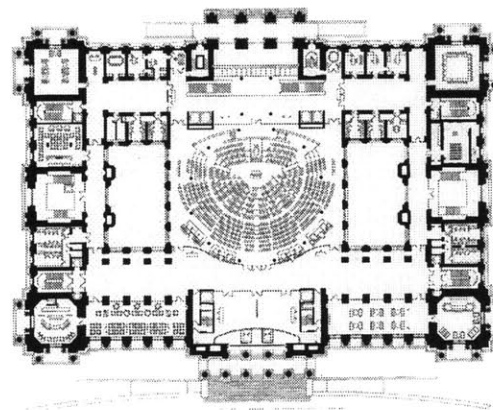
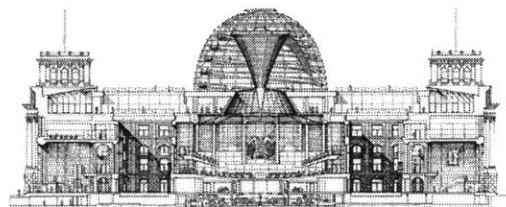

The Reichstag

From the moment of its inauguration, the Reichstag would be a symbol of German pride. It served as the seat of Parliament throughout the years of the Weimar Republic and beyond until 1933 when a suspicious fire destroyed much of the interior. Using this fire to his political advantage, Adolf Hitler declared a state of emergency and seized dictatorial control of Germany. The building experienced continuous Allied bombing from 1943 to 1945 during the Second World War. When Berlin was taken by the Soviets in May of 1945, the Reichstag became a symbolic prize for the conquerors of the city. Numerous propaganda photographs taken by the Allied forces perpetuated the Reichstag's almost mystical significance throughout the next several decades. During the Cold War, the Reichstag became a symbol of Germany's division because of its location against the border of East and West Germany. Throughout the decades of the Cold War, the West German Parliament convened in Bonn and the historic seat of Parliament was further ignored. In the 1960's a simple and highly insensitive renovation took place so that the Reichstag could be used for minor government agencies. Although functionally insignificant throughout this period, the Reichstag maintained its symbolic stature.

It was not until the reunification of German in November of 1989 that talk of the return of German government to Berlin began. In 1992 a competition to renovate the Reichstag building to be used for the new seat of Parliament for unified Germany was held. After being chosen as one of five winners in the initial competition, Foster Associates rethought and redesigned their entire proposal for the final stage of competition. In 1993 they were chosen winner of the competition. After changes were made to the design, in 1994 construction began on the new Reichstag.

After completion in 2000 The Reichstag was an immediate success. The German public adored it; although, the building was not without its critics. Some complained that the new Reichstag was more of a monument to sustainable technology and progress than it was a representation of German democracy and unification. This rather narrow opinion of the building only proves how innovative the project actually is. The fact of the matter is that the government requested a highly environmentally responsible build-

ing to represent the concerns of the German people toward the environment and the importance of sustainable practice. Foster's design outperforms all energy reduction goals initially set, and goes beyond what anyone initially thought possible.

In energy terms the Reichstag is firmly focused on the future. Its extensive use of alternate resources together with combined systems of heat and power generation and heat recovery, ensures that the minimum amount of energy achieves the maximum effect at the lowest cost. It uses daylight, solar power, and natural ventilation to provide lighting, hot water, warmth in winter and summer cooling. In fact, because its own energy requirements are sufficiently modest, the Reichstag is able to perform as a local power station, supplying neighboring buildings in the new government quarter (Jenkins 178).

The first element of the Reichstag that must be addressed is the great cupola. This feature is the center-piece of the entire project and also the one that influences most lighting, ventilation and environmental control strategies within the building. The cupola itself stands 23.5 meters above the roof of the building and has a diameter of 40 meters.

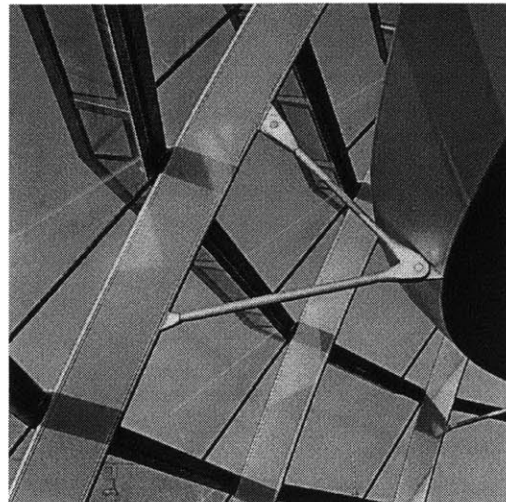

The Reichstag: Cupola Glazing Detail.

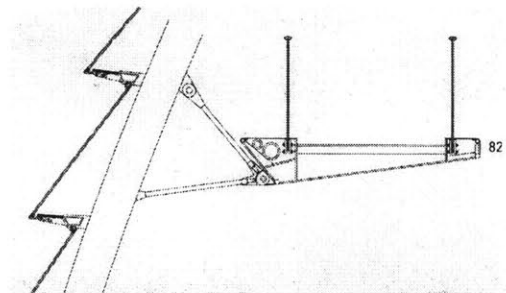

The Reichstag: Cupola Glazing Detail.

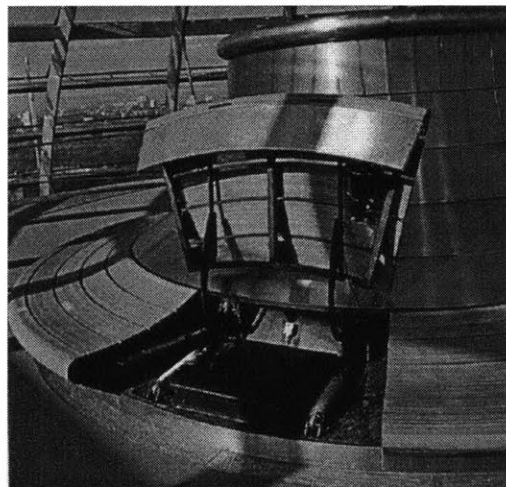

The Reichstag: Exhaust Hatch.

It is constructed of 3000 square meters of laminated safety glass. These glass panels are 5x2 meters in size and consist of two layers of glass with an intermediate layer of vinyl foil. Two helical ramps that allow visitors to journey to the top of the dome are integral to the structure. The 1.5 meter wide ramps provide lateral stiffening and vertical loading. At the top of the ramp is an observation platform that soars over 40 meters above the ground.

Resting directly above the main parliamentary chamber, the cupola, in concert with a cone covered with 360 highly reflective glass mirrors, placed at the center of the dome, bathes the chamber floor with a tremendous amount of natural light. So much in fact, that during day light hours artificial lighting is not required for many months of the year. The suspended, conical shaped mirror within the dome is also used to expel warm air from the chamber. As warm air rises to the ceiling, it is taken into the cone and released to the outside through a wide nozzle at the top of the cone. The system works almost entirely naturally. It functions by utilizing a 'flue' effect generated by the shape of both the cone and cupola. The lantern opening is fitted with a wind spoiler to encourage air flow across the top of the cupola to facilitate the extraction process; it also protects visitors on the viewing platform from adverse prevailing winds (Foster 183). Within the cone itself are mechanical fans to assist the process when required. The power to run these fans is generated by 100 photovoltaic cells, which are located on the south facing section of the roof.

The cupola itself has a sun-tracking system that can be used to block direct sunlight. Where sun angles are low enough for the sunlight not to interfere with proceedings on the chamber floor, the shading device can be mechanically moved away to let light through. When the chamber is in use after nightfall, artificial light from the chamber is reflected upwards illuminating the cupola (Evans 70).

The chamber floor utilizes a natural ventilation system. As mentioned, the conical mirror within the dome helps draw warm air out of the debating chamber and releases the air to the outside using a flue effect. Up toward the top of the dome, axial fans and

heat exchanges recycle energy from the waste air being expelled. Fresh air is drawn from the outside above the west portico and into a huge plenum below the chamber. The fresh air is then released through the chamber floor which consists of 3x3 cm mesh, perforated panels, and a porous, loose-weave carpet which acts as a filter, allowing the entire chamber floor to be used as a low velocity air inlet. This system minimizes draughts and noise within the chamber, while keeping the temperature consistent. This ventilation strategy is unique to the Reichstag, and has never been used before. The same 100 solar modules with photovoltaic cells used to power the shading device in the dome are also used to generate the power for the ventilation system. These cells have a peak power output of approximately 40kW.

It is important to note that the air intake ducts being used for the chamber floor are the original ones built into the massive walls back in 1894. These original ducts are vital to the overall strategies employed in the new system. Without them, many of the new ventilation techniques would not have been possible. Also, the new system takes full advantage of the massive walls, 6 feet thick in places, to maintain a relatively constant,



The Reichstag: Parliament Chamber.

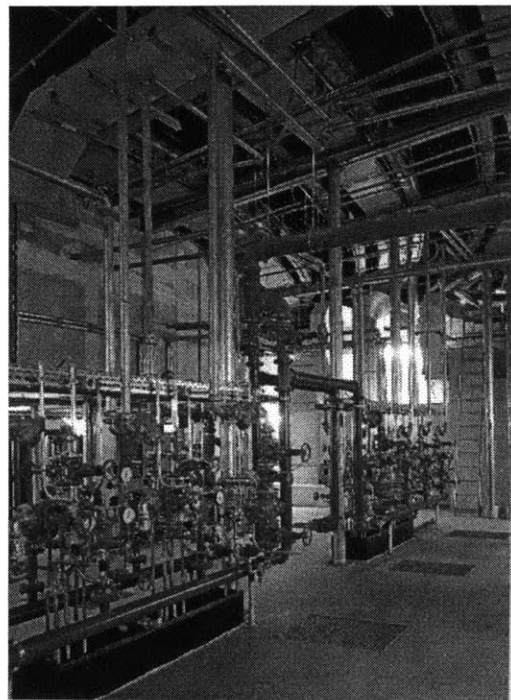

The Reichstag: Plenum Below Chamber.

comfortable temperature within the building. This inherent thermal mass provides a relatively consistent base temperature which than can be adjusted using either passive or active environmental control strategies.

Great importance was placed on operable windows as well in the new construction of the Reichstag. It was stipulated by the client, the German government, that occupants of the building be allowed to operate the windows in their immediate workspace. The windows designed for the Reichstag use the original openings fitted with a system of intelligent windows with two layers of glass that balance out extreme fluctuations of temperature. The inner windows can be opened from the inside either manually or automatically. The outer layer is laminated with a protective coating and has ventilation joints that admit air from the outside. The void between the window system houses a solar shading device as well (Schulz 107). The window system also provides a high level of security for the building, especially for night time cooling, in that the outside windows remain fixed while allowing the inner windows to be operable and even left open at night.

The Reichstag's power plant burns refined vegetable oil derived from sunflower seeds. This vegetable oil is burned in a cogenerator to produce electricity. Also know as 'bio-diesel', this is a completely renewable natural fuel. It also burns far cleaner and more efficient than traditional sources of energy production. The Reichstag use of natural, renewable, vegetable oil has allowed for a 94% reduction in carbon dioxide emissions. The building has been transformed from producing over 7000 tonnes of carbon dioxide per annum to producing less than 450. Surplus heat is stored as hot water in an aquifer 300 meters below the ground. The water can be pumped up to heat the building or to drive an absorption cooling plant to produce chilled water (Foster 133). This chilled water can similarly be stored in an aquifer 60 meters below ground for later use. Much of this chilled water stored in the cold water aquifer is used to supply the chilled ceilings in many of the offices for summer cooling.

It is important to realize when examining the Reichstag that it incorporates a combination of passive and active, high-tech and low-tech, strategies to achieve its purpose. Only through this assortment of techniques is the Reichstag able to attain the level of energy efficiency that it does. Simply because it is a high profile, high budget, technologically advanced project, does not mean that it ignores passive, low-tech sustainable strategies that have proven effective for centuries. Much like Sainsbury Centre twenty-five years earlier, the Reichstag is exactly what Reyner Banham would call 'appropriate-tech'.

The Reichstag is not simply a project case study for sustainable technologies and strategies. The incredible historic fabric of the building demanded a highly sensitive and responsible approach throughout design and construction. Though the Reichstag was certainly worthy of complete preservation due to its historical significance, a complete historic restoration would have been impractical for contemporary functions and requirements. Therefore, Foster was assigned the momentous task of renovating the entire building, incorporating cutting edge technologies, satisfying a complicated program,

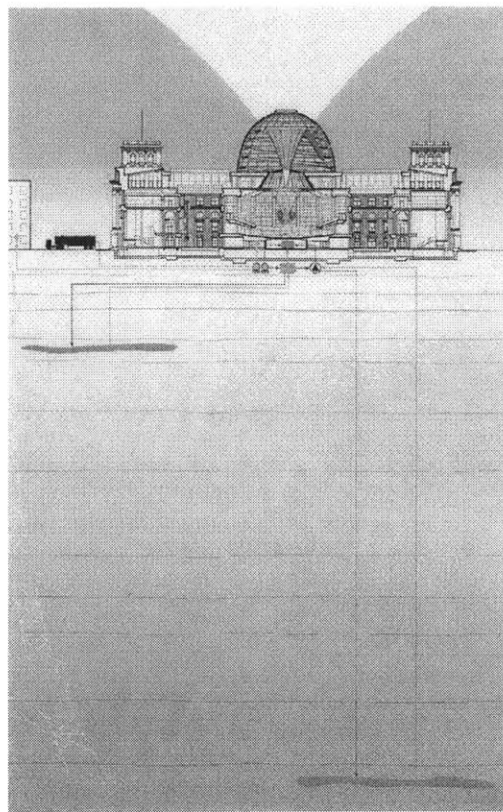

The Reichstag: Sustainable Systems Diagram.

all the while maintaining the historic integrity of this national treasure.

When the construction began in 1994, the renovation of the 1960's was peeled away. What was discovered were the historic walls of the Reichstag. And as it turned out, many of the walls were covered with Russian graffiti from the closing days of World War Two. A decision was made to retain a number of areas of graffiti. The inscriptions have been conserved by specialists who developed new techniques to preserve the Reichstag's past. The original fabric, whether damaged by the fighting at the end of the war or by the conversion work in the 1960's has been retained as far as possible in that original parts of the building are clearly distinguished from those that have been added subsequently by a finely incised shadow gap marking the transitions between the two (Schulz 65).

Ultimately, the Reichstag succeeds as a thoughtful combination of old and new. It does not sacrifice technological advancement for the sake of simple preservation. However, it also does not dismiss the past without regard for culture, heritage and memory. And finally, it does not let its pursuit of environmental responsibility, or historical preservation dictate design. It incor-

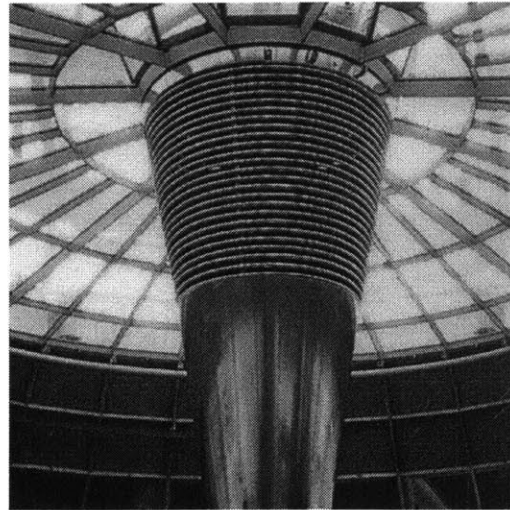

The Reichstag: Ventilation Grille.



The Reichstag: Historic Graffiti.

porates all factors seamlessly into an extraordinary magnum opus of architectural design expression. This balance is probably Foster's greatest achievement with this building. He was able to construct one of the most technologically advanced, sustainable buildings in the world while simultaneously, preserving a piece of national history for the German people.

The Reichstag is indicative of Foster Associates attitude toward technology and sustainability. For decades Foster has considered energy conservation as simply one of many constraints of architectural design that can be acknowledged in positive ways; it is never an excuse for poor design. Energy is a servant of architecture, not a master. It is to be used, but used intelligently (Butt 11).

The Reichstag project is also quite telling of Foster's development over the last three decades. Early in his career he experimented with technologies and sustainability as with the Willis Faber building and Sainsbury Centre, and created quite remarkable projects for their time. However, the Reichstag's technological achievement sets a new standard for all that follow. Obviously, technological capabilities have progressed in the

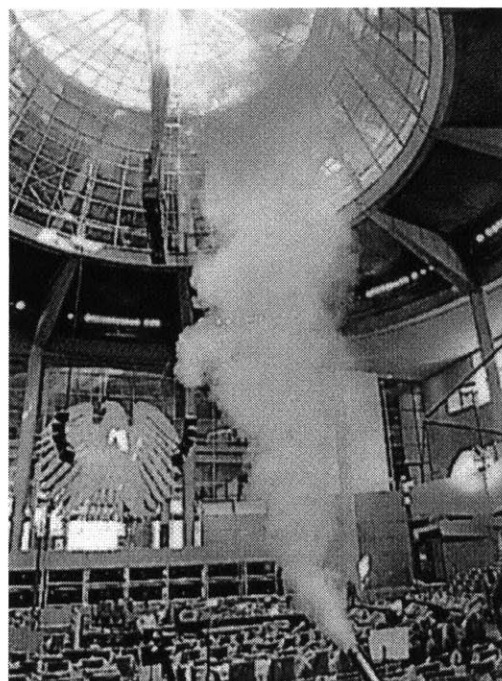

The Reichstag: Ventilation Flow Test.

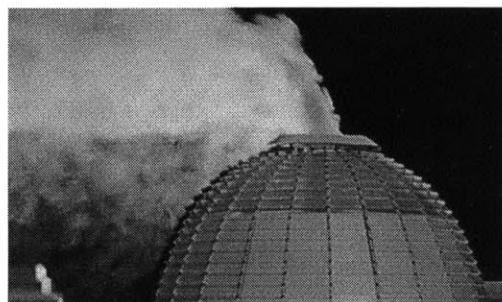

The Reichstag: Wind Tunnel Test.

last thirty years. This is certainly a factor when comparing Foster's early work with his later projects. However, it is important to note that much of the sustainable technologies developed over the years has been directly related to Foster's projects and research. He has consistently been on the leading edge in this field. Few architectural firms in the world have continued, not only to research, but implement advanced, and many times experimental, technologies into their work. This is one of many factors that sets them apart from most of the discipline and solidifies them as standard-bearers.

In coming chapters we will examine architects and designers, like Richard Meier, who have only recently become concerned with issues of sustainability and energy efficiency. We will also explore how Norman Foster and his work has influenced some of these 'new-comers', and provided them with a paradigm to follow. Also, the work of Foster Associates over the past thirty years, has provided a myriad of precedents and case studies for a younger generation to learn from and improve upon.

Chapter 4
Richard Meier: From White to Green

Richard Meier has never been known for his environmental sensitivity. Until recently, he has treated his gridded metal skins and glass curtain walls as abstract surfaces, without much regard for their thermal performance or energy efficiency. However, Meier's recent attention to energy and environmental performance is changing not only his design process, but also the buildings themselves (Barreneche). Because of this very simple fact, Richard Meier, becomes a pivotal character in our search for sustainable architecture as it relates to serious design expression. In our last chapter, we explored the work of Norman Foster who is representative of a handful of architects that have spent their entire careers investigating the synthesis of sustainable technologies and high design. In our current discussion, Richard Meier, is representative of countless architects who have only recently begun exploring sustainability issues in architecture. This is what makes Richard Meier so significant to our discussion. Meier and his work are in many ways symbolic of a shift in attitude within the discipline of architecture toward sustainability, energy efficiency, and a newfound responsibility of architecture to the environment.

Richard Meier, for decades, was arguably the preeminent living American architect. The irony being that his architectural formal devices are far more European than American. Meier has built a career by remaining stubbornly faithful to a staunch, heroic-twenties, avant-garde vocabulary. These Modernist tendencies were most likely learned from his teacher and mentor Colin Rowe while at Cornell University in the 1950's. Obviously heavily influenced by Le Corbusier, the significance of Meier's early work is his manipulation of basic architectural elements within a once austere vocabulary. Very early in his career Meier devised a parti for a multistory, basically rectangular building that is approached through a dense section of smartly aligned rooms opening into a voluminous space enclosed in glass. Through this organization, he introduced many issues; the progression from dark to light, small to large, solid to void, and promenades

architecturales on bridges, ramps, and staircases (Giovannini). Meier has also always been very conscious of layering within his buildings. His interest in spatial layering and collage afford his projects a useful organizational tool to define both space and physical elements. Early in his career Meier's buildings remained relatively geometrically severe while utilizing many of the aforementioned techniques. He continued with this somewhat formulaic, yet highly successful, vocabulary for many years and produced a myriad of important works. Later in his career, Meier would introduce baroque influences into his designs that would provide another layer of complexity.

For the purpose of our study, we are most interested in Richard Meier's current work that incorporates sustainable technologies into his design vocabulary. However, to make lucid the dramatic shift that has occurred within Meier's designs, it is fundamentally important to this discussion to briefly address some of his early work. Only by achieving an understanding of what made Meier such a recognized and revered figure in the world of architecture, may we truly appreciate the significance of his newfound interest in sustainable issues. Therefore let us direct our attention to two of Richard Meier's early works, the Smith House in Darien, Connecticut, and the Douglas House in Harbor Springs, Michigan.

In 1963 Richard Meier established a private practice and launched his business with a commission from his parents, a residence in Essex Falls, New Jersey. Two years later in 1965 Meier would build a house that would change his life forever; the Smith House in Darien, Connecticut (1965-1967). This house would become a virtual manifesto of his contribution to architecture in the last quarter of the twentieth century. Five years later Meier built the Douglas House in Harbor Springs, Michigan that was for all intents and purposes, quite similar to the Smith House. This was due to the fact that the clients of the Douglas House, having seen the Smith House in a publication, requested a house comparable in style and vocabulary to the Smith House. Due to the dramatic site of the Douglas House, and of course architectural integrity, Meier did not design a replica of the earlier house. He did however, build a house utilizing not only a similar vocabulary, but similar design principles, techniques and design strategies. Most likely, because of

the dramatic site of the Douglas House overlooking Lake Michigan, the project in time, became a more celebrated work than its distinguished predecessor.

The Smith House was Meier's first comprehensive essay on modern architecture. It is also the first of his pristine white buildings that would ultimately become his signature aesthetic. The key elements associated with his work are present in the Smith House; the brilliant white exterior, expanses of plate glass framed by finely proportioned piers and mullions, distinct circulation features, minimal interiors and programmatic separation between public and private spaces. There is also clear commentary about issues such as the separation between exterior and interior space, concerns with direction and movement and planar abstraction (ed. Green).

The hard edges of the Smith House are set in opposition to a rugged coastline. The front walkway establishes a major site axis. One approaches an almost solid façade before crossing the front ramp and entering onto the second floor of what Meier terms a "180-degree explosion". The public spaces; living room, dining room, and terraces all open to the waterfront view while the private realm is contained in the envelope core (ed. Green).

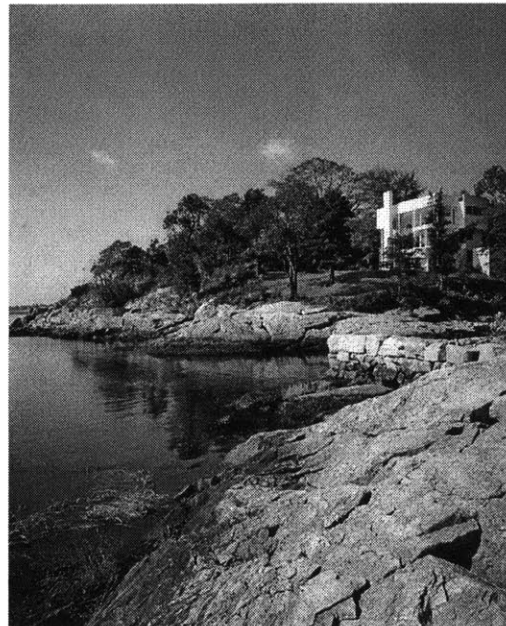

Smith House, 1965.

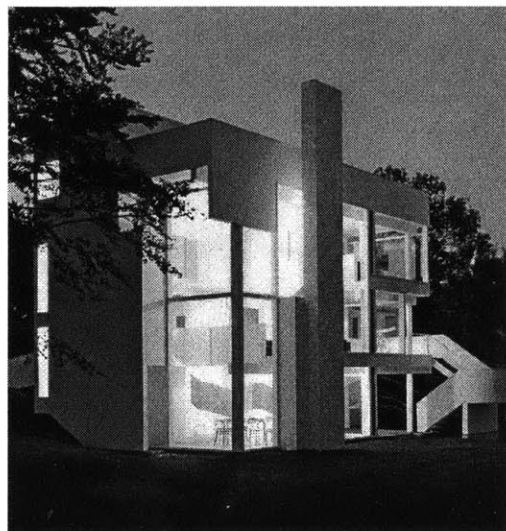

Darien House, Connecticut, 1967.

Programmatically the Douglas and Smith houses are quite similar. Due to the extraordinary site however, the design for the Douglas house evolved somewhat differently. There is a sharp downhill grade of the land that requires the house to be entered from the roof level by a flying bridge and seems to shear off the top of the frontal plane. The only parts of the edifice visible from the road are the roof and top floor; not until one crosses the bridge does one perceive the five stories and 4,500 square feet of interior space. As in the Smith House, the separation between public and private spaces is expressed by solid and glazed walls respectively. The public side, the west, provides a lake view from all floors. The east side, facing the road in the private zone, having smaller fenestration, and containing bedrooms and service spaces on all three levels (ed. Ockman).

The Smith and Douglas Houses reveal themselves as deliberately conceived like artificial objects inserted into the natural landscape, with which they establish a relationship of visual contract. Their respective sites are similar: a wooded slope beside the water shore. The answer to this setting is a prismatic volume rising over the terrain and defined by two planes, each clearly different in character to the other. In terms of spatial organization, these two houses constitute a typological contribution of Richard Meier to twentieth century residential architecture (Sainz). This tripartite organizational structure basically consists of three zones; the public space consisting of living and dining, the private containing the bedrooms and baths, and the third zone being the circulation space which clearly separates the first two. A simple organizational strategy which had a significant impact on American residential architecture for decades to come.

The Smith and Douglas Houses are both very good examples of Richard Meier's early work. These houses launched his career as one of the leading American architects of the 1970's. It is important to note in this discussion of Meier's early work the design intentions and patterns that were established. The early work of Richard Meier is quite complex with strong references to early modernism. He pays particularly close attention to spatial complexities, light, detail, color and clear organizational strategies just to name a few. There is however, absolutely no concern for environmental issues or energy efficiency. This fact is not intended to take anything away from Meier's early

masterpieces. It is simply indicative of the interests and priorities of not only Richard Meier at the time, but of a larger architectural community as well. However, the significance of understanding his early design intentions is that we will be better prepared to acknowledge the shift that Meier makes later in his career toward sustainable technologies and techniques in his work.

Once recognized for his poetic residences, Richard Meier began the next phase of his career where he predominantly built museums. And a discussion of Meier would hardly be complete without at least a token mention of the Getty Center in Los Angeles. This project marks a turning point in the career of Richard Meier. While the project itself is now considered one of his least successful works, it is considered unsuccessful due to circumstances beyond Meier's control; committee politics, mediocre interior designers, neighborhood associations, and design by committee. The Getty Center commission which Meier received in 1984 was the last large project where he does not include sustainable technologies or strategies. This project is traditional Meier, while most projects after the Getty Center signify a new phase in Meier's career. Before the completion of the Getty

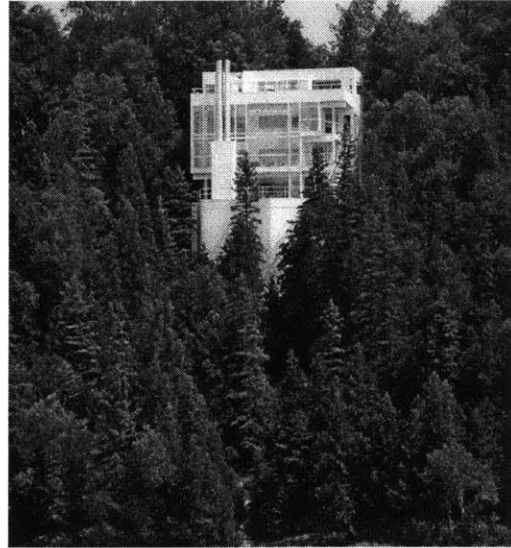

Douglas House, Harbor Springs, MI. 1972.

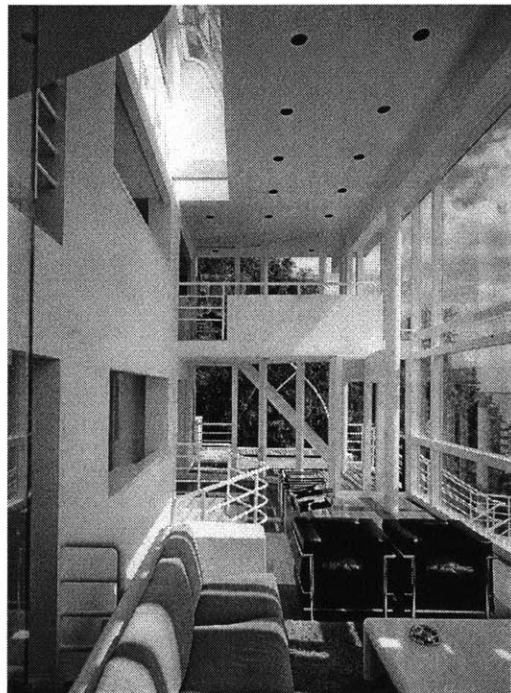

Douglas House, Harbor Springs, MI. 1972.

Center in 1998 Meier had turned his attention toward an integration of sustainable technologies and passive techniques within his buildings.

Though not the first building in which Meier incorporates sustainable strategies into his work, the Museum of Contemporary Art in Barcelona (1995) is one of his early successful attempts. It is also important to note that design partner Thomas Phifer had a pivotal role in this project and should be credited with bringing a new dynamic to this project. While Meier and Phifer remained faithful to the signature Richard Meier strict-Modern style, they brought an element of energy efficiency to the project that has been praised not only by the owners of the building, but by the larger architectural community as well.

The Museum of Contemporary Art in Barcelona is a clean white box overflowing with daylight. It is this emphasis on daylight and day-lighting strategies that make this project stand apart from other Richard Meier white box museums before it. The lighting strategies inform all aspects of the building; from the organization of gallery spaces, façade treatments, to a uniquely designed environmentally sensitive sunscreen

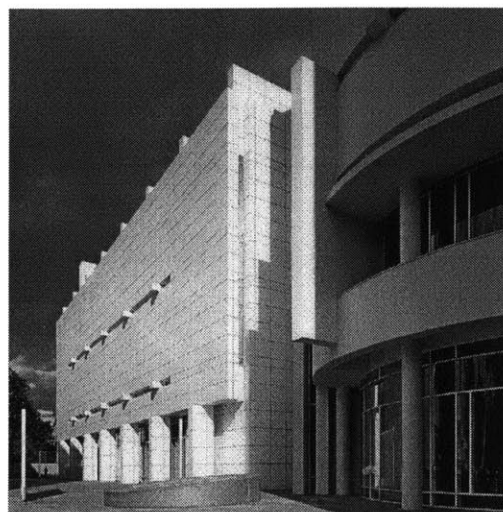

Barcelona Museum of Contemporary Art, 1996.

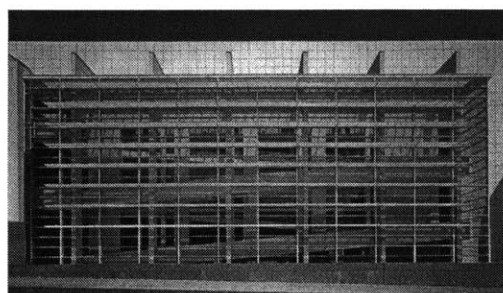

Barcelona Museum of Contemporary Art: Exterior Louvers

system that mediates the strong Mediterranean sun. Thomas Phifer explained in an interview in 1996 regarding the museum “We believe very strongly that art should be viewed in daylight, so we tried to get natural light into just about every space”. Though this objective may appear ordinary, it is rather ambitious for a museum project. And this objective of bathing the interior of the museum with natural light while simultaneously protecting the sensitive works of art and preventing a strong glare, is what led to an interesting system of louvers and sunscreens.

In the museum’s main gallery space, the sky and its changing conditions remain visible while sunlight is reflected into the galleries through a grid of 40-centimeter-wide, fixed aluminum blades. The fin-shaped blades are held in place by steel support that spans the skylights’ framing members. These skylights are glazed with laminated, insulated glass with a UV-protective inner layer. Above the other galleries, smaller blades, similar to Venetian blinds were installed, inside four-foot-wide skylights to similarly control day lighting. The museum’s south facing façade is elegantly shaded by light-weight brise-soleils composed of 1-inch diameter rods that are supported by aluminum



Barcelona Museum of Contemporary Art

brackets bolted to the double mullions of the glass curtain wall. This system affords visitors to view the exterior plaza while providing sufficient shade to the façade (Barreneche).

The Barcelona Museum of Contemporary Art is, by no stretch of the imagination, a sustainable building. However, it is a significant stride in Meier's evolution toward sustainable intentions. The lighting strategies in this project do add to the overall elegance of the interior space, which is typical of almost any Meier work. The difference in the Barcelona Museum is that techniques are also used to limit direct radiation from heating the interior of the building. Significant effort and resources were expended to control light and heat through both passive and active means.

Arguably most significant about the Barcelona Museum of Contemporary Art is the way in which Richard Meier, along with partner Thomas Phifer, address heat gain issues. The strategies used are integrated seamlessly into both the process, and ultimately the form of the building. The louver and sunscreen systems participate in a graceful dialogue with the rest of the edifice. The elegant volumes of space inform the environmental control systems, and in turn, these systems are afforded the opportunity to inform the space. Much like the work of Norman Foster, Richard Meier has allowed the control systems to contribute to the design of the building, without sacrificing his valued aesthetic intentions and architectural expression.

The next project we will address is the U.S. Courthouse and Federal Building in Phoenix, Arizona completed in January of 2000. This project marks another important step in Richard Meier's metamorphosis toward the use of sustainable technologies within a clear design expression. It is also interesting to note that the Phoenix courthouse is a departure from Meier's typical white box aesthetic. This formal divergence is undoubtedly due, in part, to the large glass hall of civic proportions.

Being the primary formal gesture of the building, this indoor civic space was designed as an intermediate experiential zone between the fully conditioned courtrooms and the extreme temperatures of the southwestern Sonoran Desert. The hall or atrium, which

the entire courthouse is organized around, is a 4,800 square-meter rectangle that is clad entirely of glass on its east and north facades. To shade this substantial public space, louvers are arranged inside the delicate truss structure of the roof, which, similar to the louvers of Meier's Barcelona Museum, are constructed of a series of small steel rods. The skylights above the grand room are clad in a single layer of clear laminated glass. As air is trapped between the glass and the louvers it is heated by the sun's radiation, and is vented out through the ends of the roof assembly by naturally induced currents.

Due to the severe desert climate, all facades in the project are specific to orientation to help control unnecessary heat gain. The north wall enclosing the atrium is constructed of single-pane glazing, secured in place by an aluminum curtain wall frame braced by tubular steel struts. On the east face of the building, aluminum rods placed between the layers of a double-pane glass assembly, shield the glass from direct morning sun. The offices along the south and west elevations, which receive the most sun exposure, employ both exterior horizontal sunscreens and high efficiency low-E, ceramic fritted, insulating glass supported by an aluminum curtain wall. These sunscreens de-

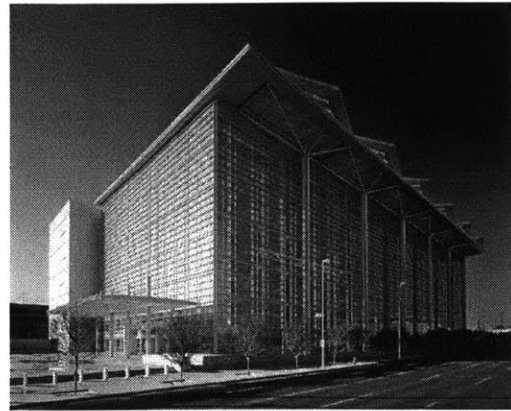

Phoenix Federal Courthouse, 2000.



Phoenix Federal Courthouse: Entrance Canopy

vices consist of slender pieces of aluminum called snap-caps. On the south façade, these devices virtually prevent direct daylight from entering the building. Phoenix, Arizona, at 33 degrees north latitude, has a relatively high sun angle. This allows shallow million covering to adequately replace wider brise-soleils like the ones used in the Barcelona Museum of Contemporary Art. Also, translucent fabric shades positioned on west-facing windows protect from harsh afternoon sun (source: Richard Meier & Partners).

The large glass hall with its interior height of 100-feet is cooled by a process called adiabatic evaporation. This process occurs when water absorbs heat energy from the surrounding environment and changes its state from liquid to gas. The effect is achieved with systems that spray a fine mist of water that quickly and completely evaporates into the air. The cooling provided by this process can be correlated with a change in air humidity as it picks up moisture through evaporation. The range of temperatures achievable through adiabatic cooling is thus affected by initial temperature and humidity of the incoming air, and has a lower limit imposed by achieving 100% relative humidity, or maximum saturation of the air.

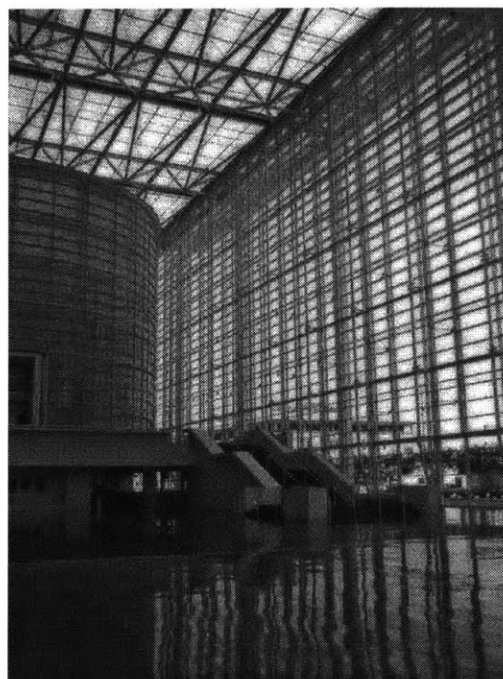

Phoenix Federal Courthouse: Atrium.

In the Phoenix Courthouse, it was found that by placing the adiabatic cooling sprays above the balconies, a stable air flow pattern could be achieved. Air enters the atrium through an inlet located below the shading device. The air moves upward through the shading device, picking up solar heat on its way, and then exits through outlets on the north façade above the shading element. Part of the incoming air reaches the misting nozzles above the corridors and is adiabatically cooled. The cooled air, with its higher density, descends along the face of the corridors, assisting the corridor air curtain, and forms a pool of cooled air at the base of the atrium. The air then flows out through openings a few meters above the floor level on the east façade and through the main entrance doors (source: Ove Arup & Partners).

Ken Lufkin of Langdon Wilson Architecture in Phoenix, the local firm assisting Richard Meier & Partners on the project, describes the adiabatic system as creating “a chimney effect that drives the atrium passively”. By this phenomenon, the increase in the humidity of the space generates a substantial drop in air temperature, without a significant addition of energy. By natural and economical means, the Phoenix Courthouse provides a comfortable environment derived from

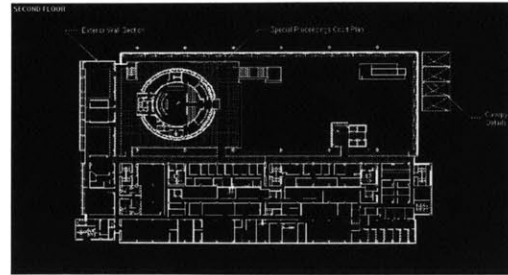

Phoenix Federal Courthouse: Plan.

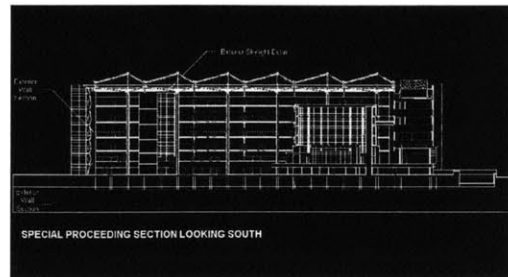

Phoenix Federal Courthouse: Section.

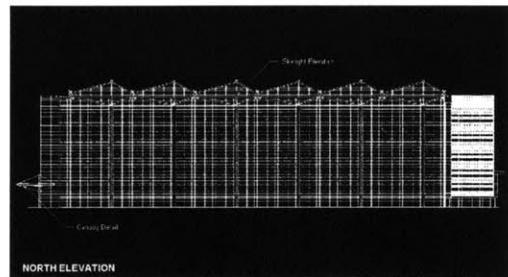

Phoenix Federal Courthouse: Elevation.

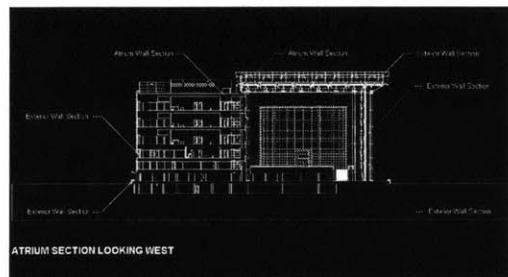

Phoenix Federal Courthouse: Cross Section.

specifically indigenous conditions (Smith).

Along with the innovative environmental control strategies within this project, the buildings large scale, geometrically simple form proclaims its civic role. The Courthouse is a tasteful addition to the downtown Phoenix community. Richard Meier, and Thomas Phifer who also worked on this project, did not ignore those signature characteristics that many have come to expect from a Meier building; attention to natural day lighting, an elegance of tectonic detailing, complex spatial relationships, and of course, simple yet powerful geometric volumes. Meier also brought in internationally recognized consultants like glass artist James Carpenter to assist with overall detailing and the large glass ceiling of the main, ceremonial courtroom.

The Phoenix courthouse is an interesting case study for our discussion, in that it is a project in which Meier's entire design is motivated by the climatic conditions of place, and the environmental strategies employed. Will Bruder said of the project "It's a building that's about technology, but about low technology, which is wonderful". This is an important distinction that Bruder makes. The buildings climatic control strat-

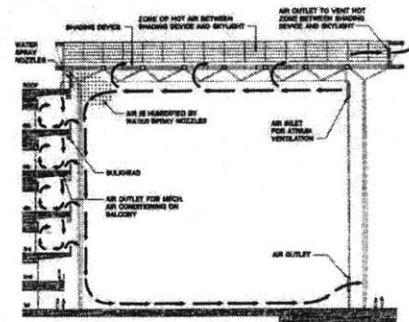

Adiabatic Evaporative Cooling System

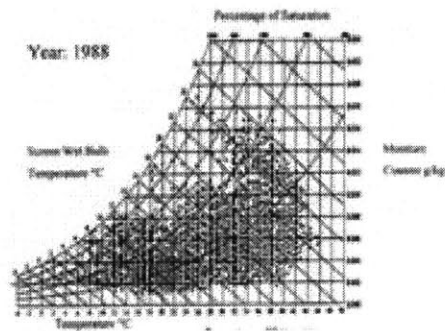

Psychrometric Chart

egies are not overly expensive, high-technology, systems. They are for the most part, passive. Meier incorporates the use of sunscreens, louvers, shading canopies, proper orientation, and a rather simple adiabatic evaporative cooling technique. Yet, all of these elements together, provide for an effective response to the severe desert conditions. And not only do they offer effective environmental control, but they also inform the overall design and the formal implication of the project as well.

As we have seen Richard Meier has significantly adjusted his architectural position over the course of his career. In his early work, the Smith and Douglas houses, Meier was focused on complicated, even esoteric, architectural objectives. He was an archmodernist preoccupied with diagrammatic clarity, spatial intricacy, geometric volumes, and the complexity of light and shadow. These interests produced some of the twentieth century's finest architectural works to be sure. However, in his later work, Meier brings a new layer of significance to his projects. The formal complexities mentioned that once characterized his porous designs, are now further developed by climate-sensitive building strategies. Although Richard Meier's buildings have evolved in

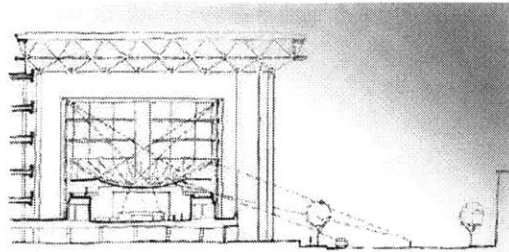

Phoenix Federal Courthouse: Concept Sketch



Phoenix Federal Courthouse: Glass wall, interior view

their design intentions, his work retains the identifiable style that makes his buildings such sought-after collectibles for cities around the world with cultural aspirations (Giovannini).

At the age of forty-nine, Richard Meier was the youngest ever recipient of architecture's highest honor, the Pritzker Prize. Only after achieving such an elevated position within the discipline of architecture, did Meier evolve his design philosophy to involve sustainable technologies to further advance his work. As suggested early in this chapter, it is the position of this thesis that Richard Meier is indicative of a much larger movement. Meier's acknowledgement and advancement of sustainable technologies is representative of an entire discipline that once ignored such issues in favor of formal characteristics, esoteric symbolism, and stylistic intentions. Meier and his work, become important case studies in that they demonstrate that the landscape of the discipline has changed. More is required of both architects and buildings today than was ten years ago. Richard Meier continues to be successful not only because of his superior design abilities, but because he has chosen to evolve with a discipline that continues to progress toward environmental responsibility.

Chapter 5

The Emergence of Sustainable Practice in Superstructures

A recent phenomenon within the discipline of architecture, that cannot be overlooked, is the emergence of sustainable technologies in high-rise buildings. Concerns for energy-efficiency and the environment have initiated significant developments in the sustainability of small-scale projects over the last twenty years. Unfortunately, the conventional, proto-typical skyscraper has remained immune to such advancement in sustainable technologies and techniques. However, within the last decade, as environmental concerns have permeated all aspects of society and culture, the negative impact of the mega-structure has finally been addressed. This new emphasis on creating environmentally responsible mega-structures, through the use of emerging technologies, has begun altering the formal vocabulary of large-scale buildings in ways never seen before. Through these new formal vocabularies a new architectural typology is emerging; the bioclimatic skyscraper.

Throughout the first several decades of sustainable research, much of the focus has been on small-scale structures and other works of limited scope. This fact is clearly understandable in that smaller interventions and case studies are of a manageable size and cost, for researchers and designers investigating experimental, sustainable technologies. These smaller projects also afford researchers a more isolated, and comprehensible laboratory in which to analyze and document the affectedness of specific systems and techniques associated with sustainability. While small projects afford researchers a precise and effective way in which to advance sustainable systems, these technologies will remain limited in use unless they are implemented on a larger scale and in larger projects.

Although mega-structures or skyscrapers are the most intensive, high-energy use buildings in existence, they are the ones that have historically benefited least from sustainable technologies. Skyscrapers by their very nature consume large amounts of energy

and materials, and similarly make extensive discharges into the environment, thus are inherently un-green (Yeang). Because of this, it has been widely accepted within the discipline of architecture that to make a “green” mega-structure would be too expensive and too difficult. This complacent attitude has perpetuated, for decades, the construction of environmentally unfriendly buildings throughout the world. However, Kenneth Yeang, a leading advocate of sustainable mega-structures, has argued for the better part of two decades now, that high-density, intensive use structures should command a greater part of our attention and expertise than smaller buildings which present fewer problems. These huge structures in high-density urban environments contribute greatly to, not only the massive energy consumption of cities, but also to many of the unhealthy qualities associated with them. These skyscrapers are responsible for such a large percentage of energy consumption and negative environmental health issues, that by addressing the ecological problems associated with these mega-structures, there is the potential for great positive impact.

Historically, seminal landmark skyscrapers such as the Mies van der Rohe’s Seagram Building or Skidmore, Owings and Merrill’s Sears Tower have consistently subscribed to the Modernist sealed, glass box paradigm. While the oil crisis of the 1970’s sparked a movement of sustainable research and development in small-scale architecture (mostly single family residences), it failed to alter any patterns associated with high-density, energy intensive, large-scale construction. Not until the last decade of the twentieth century has the ecological impact of mega-structures and skyscraper been addressed. Not only has this issue come to the forefront within technological research and academic realms, but it has manifested itself in the physical construction of a myriad of high-profile, high-budget projects throughout the world. It is the position of this paper that these recent widespread concerns with the environmental impact of mega-structures represent both a redirection within the discipline of architecture toward sustainability, and are indicative of a larger cultural phenomenon associated with ecological concerns.

When addressing the ecological impact of mega-structures, it is not simply the issue of energy conservation that is significant. There is a connectivity that must be addressed.

Energy conservation must work in tandem with considerations of minimizing construction waste, building with recycled materials, using renewable energy sources such as solar power and wind to service the building, providing clean air and naturally ventilated interior works space for employees and occupants, and water conservation and reuse. These factors, only in combination, provide for a holistic approach to environmentally sensitive design.

This trend associated with improving the environmental responsibility of the urban mega-structure may be attributed to many factors. The three most apparent, and possibly most fundamental, are the issues of (1) monetary savings, (2) the emergence of cultural concern for environmental issues, and (3) corporate public relations. The monetary savings for large-scale buildings reducing energy consumption is obvious. Even a modest, large-scale project with 300,000 square feet of interior space that requires perpetual conditioning, could save tens of thousand of dollars annually by reducing energy consumption only 10-20%. Also, savings will continue to increase as sustainable technologies advance and become more efficient. This fact has proved to be effective encouragement for the owners of these projects to seek energy efficient technologies and strategies.

The issues of corporate-public relations and cultural concern for the environment are quite closely connected. These two elements are less quantitative and less tangible than are the statistical facts of high-energy consumption related to cost. In recent years significant attention has been focused on environmental and conservation issues within our society. Corporate entities and government agencies mostly responsible for the commission of large-scale projects are inevitably aware of this fact, and understand that building ecologically friendly projects portrays a commitment to civic values and the public welfare. Public opinion has proved to be a significant motivating force for corporate entities to be (or appear to be) more environmentally responsible.

There are a number of recent projects that have been influential in advancing the issues of ecological responsibility in mega-structures. Many of them are not only on the cut-

ting edge of sustainable technologies and techniques, but they are also designed by architects who understand the importance of synthesizing emerging technologies with design in a way as to afford each the opportunity to influence the other. By exploring a wide cross section through the industry and looking at the architects and firms who are advancing these issues, one may begin to gain an understanding of the ubiquitous nature of this trend as a redirection toward ecologically sensitive mega-structures. In this chapter we will look closely at projects by large corporate architecture firms such as Skidmore, Owings and Merrill who have, for decades, designed and constructed skyscrapers and other large scale buildings. And although they have built large-scale urban projects for years, they have, only recently, begun implementing sustainable technologies as an integral and significant part of their designs. We will also look at small firms like Morphosis who have been responsible for influential, highly theoretical, avant-garde design expressions, but whom also, only recently, have gravitated toward emerging environmental control technologies in their work. Lastly we will look at designers like Kenneth Yeang, and Norman Foster who have dedicated their careers to the pursuit of these issues. We will explore

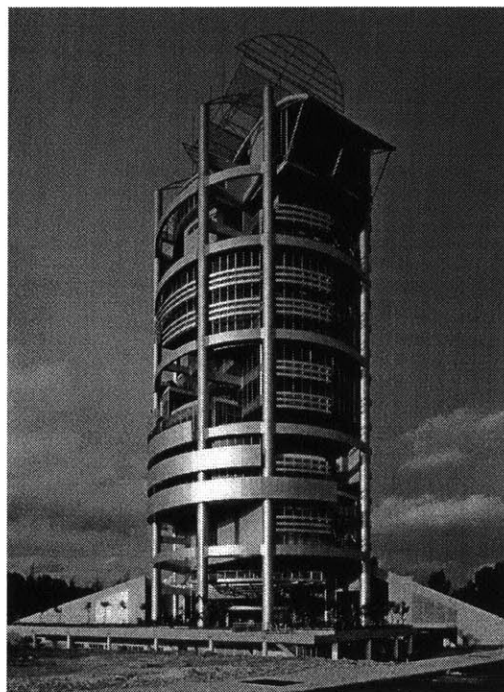

Menara Mesiniaga Building,
Hamzah and Yeang, 1992.

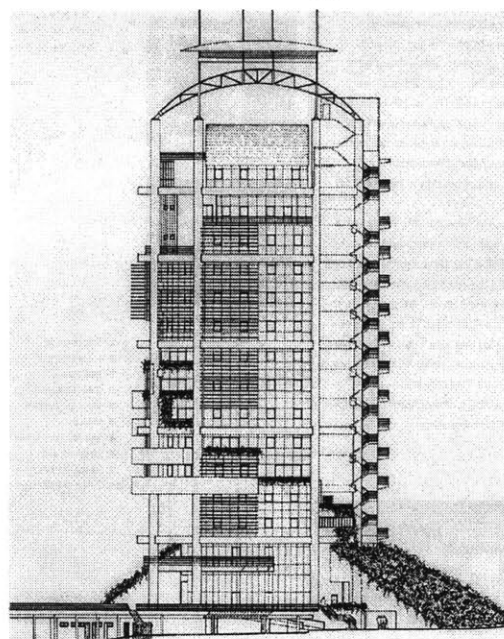

Menara Mesiniaga Building: Section.

some of their early work as juxtapose to their later projects and hypothesize as to their role in advancing the discipline toward environmental responsibility.

Two of the earliest mega-structure works to address ecological issues are the Menara Mesiniaga Building in Malaysia by the firm Hamzah and Yeang, completed in 1992 and Norman Foster's Commerzbank Headquarters in Frankfurt begun in 1992 (not completed until the summer of 1997). These two projects are indicative of the commitment that Yeang and Foster have consistently made to the research and implementation of sustainable technologies in their respective work. These two works were also the predecessors to many subsequent projects by a myriad of different architects, and proved that sustainable technologies could in fact be implemented effectively in large-scale buildings.

Yeang's Menara Mesiniaga Building represents a culmination of his early research on bioclimatic design in tall buildings. The design of this building grew out of Yeang's belief that research should be the foundation of design, and that contemporary architects have the opportunity to transform architecture from a once seemingly capricious

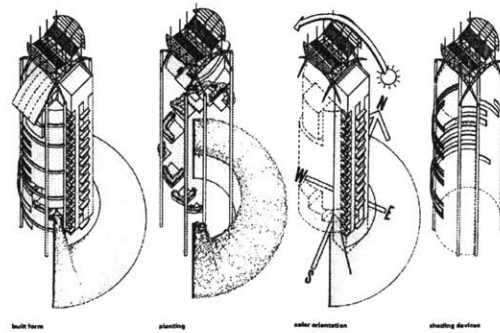

Menara Mesiniaga Building,
Hamzah and Yeang, 1992.

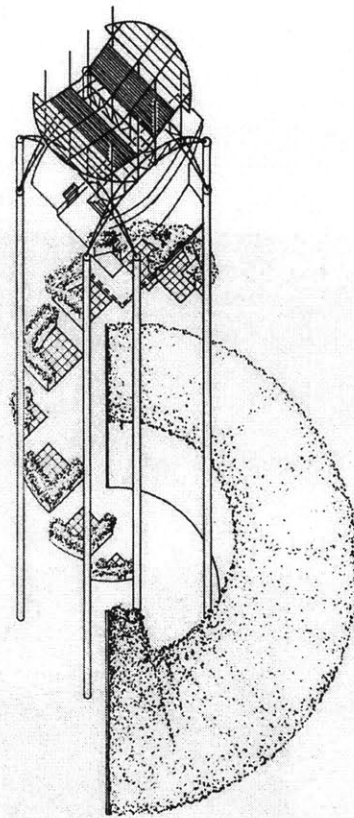

Menara Mesiniaga Building,
Hamzah and Yeang, 1992.

craft into a confident science. This project employs a variety of strategies never before fully experimented with in a large-scale building. One of the more revolutionary techniques used is Kenneth Yeang's idea of a vertical spiral-garden. This vertical garden is situated in a staggered manner, rising vertically from the base, spiraling up the outer façade of the circular tower, allowing the plants to receive the maximum amount of daylight, rainwater, and fresh air. The vegetation cools the building and provides the occupants with a sense of connection to the outdoors and nature (Gissen, ed.).

Passive low-energy features are also incorporated into this project. All of the windows on the east and west facades, that receive the most direct solar radiation, are recessed into the structure and have external louvers to provide shading and reduce heat gain into internal spaces. The north and south facades, which do not receive direct radiation, are constructed of glazed curtain-walls that afford optimum views and provide opportunity for natural ventilation. Also, most interior spaces, including all circulation space, lobbies and lavatory's, are naturally lit during the day and are naturally ventilated requiring no mechanical conditioning eight to nine months a year.

Most significant about this project is how it addresses the possibilities of future technologies. When this building was being constructed in 1991, many of the technologies routinely employed today, in 2003, were still in their infancy and thus, inefficient and expensive. Acknowledging the fact that technologies and sustainable techniques would improve, Yeang designed the Mesiniaga Tower to be able to easily adapt to these future developments. One of the primary considerations taken for future strategies to reduce energy consumption is a large roof structure erected to accommodate photo-voltaic panels when the technology became more efficient and economically beneficial. Also, the glazed curtain wall on the north and south facades were constructed in a manner that might facilitate the addition of transparent solar collecting panels in the future.

The Commerzbank in Frankfurt designed by Norman Foster and Partners is another seminal project in the evolution of sustainable high-rise structures. This building begun in 1992 is considered one of the world's first ecologically sensitive mega-structures.

The difference between the Commerzbank and Yeang's Mesiniaga Tower is scale. Yeang's project completed five years earlier made significant strides toward proving that sustainable technologies were viable in large-scale projects, however, the Mesiniaga Tower is relatively modest at fifteen stories. The Commerzbank building conversely rises over fifty-three stories above Frankfurt's downtown urban center making it, at 984 feet, Europe's tallest building.

This project is structured around a 49-story ventilating atrium at the center of the building. Surrounding this atrium in a spiraling, staggered fashion are 13 three-story-high gardens. This combination of atrium and sky garden provide the emphasis of the tower in which all other ecological strategies revolve. The three-story sky gardens throughout the building are situated in a way that all floors, of the triangular shaped building, have offices on only two sides. Subsequently, all offices have the advantage of not only looking into to the gardens, but also receive natural light and benefit from the natural ventilation and the cool micro-climate of the garden spaces. The exterior side of the gardens are faced with operable, double-glazed panels, but the interior is completely open to the atrium. Daylight is fur-

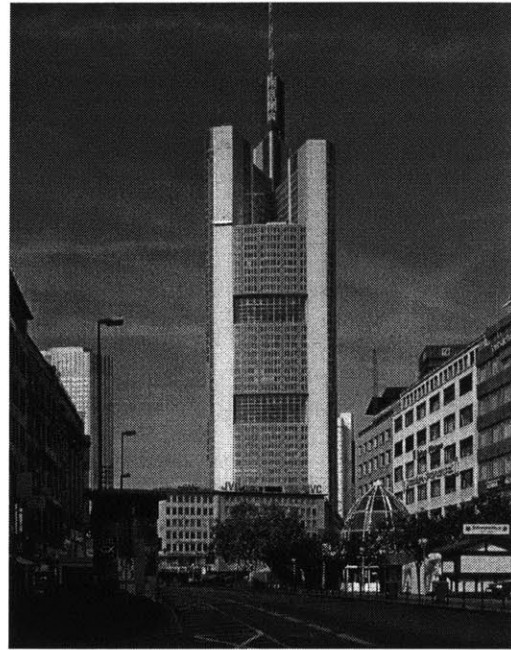

Commerzbank,
Norman Foster and Partners, 1992.

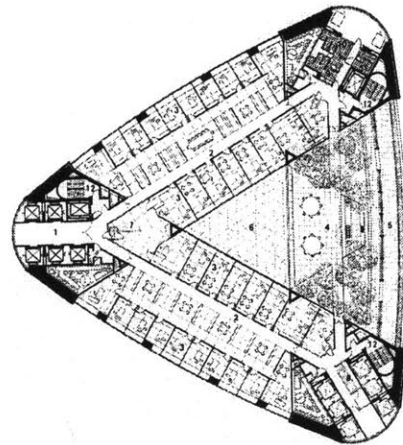

Commerzbank: Plan.

ther enhanced within the office spaces by the structural system used within the building. Eight-story-high Vierendeel beams afford an uninterrupted clear-span within the offices and allow them to take maximum advantage of natural light.

In tall mega-structures, operable windows for ventilation are typically not used because even the smallest opening can unbalance the mechanical system and draw in severe wind drafts. To permit natural ventilation, Foster in collaboration with Arup and Partners, developed a rather ingenious wall system. This double façade system, is comprised of an exterior layer of fixed, single-glazed, laminated, radar-absorbent glass; a middle air cavity; and interior double-glazed, low-E operable panels (Pepchinski). This system affords occupants the opportunity to either receive controlled, cool, outside air on warm days, or to close off the internal panels when cool air is undesirable. The operable louvers in this wall system may either be manually controlled or operated by sensors that continuously monitor and adjust the system. While conventional conditioning systems are in place to supplement the natural ventilation of the building, the passive strategies employed reduce energy consumption by fifty percent.

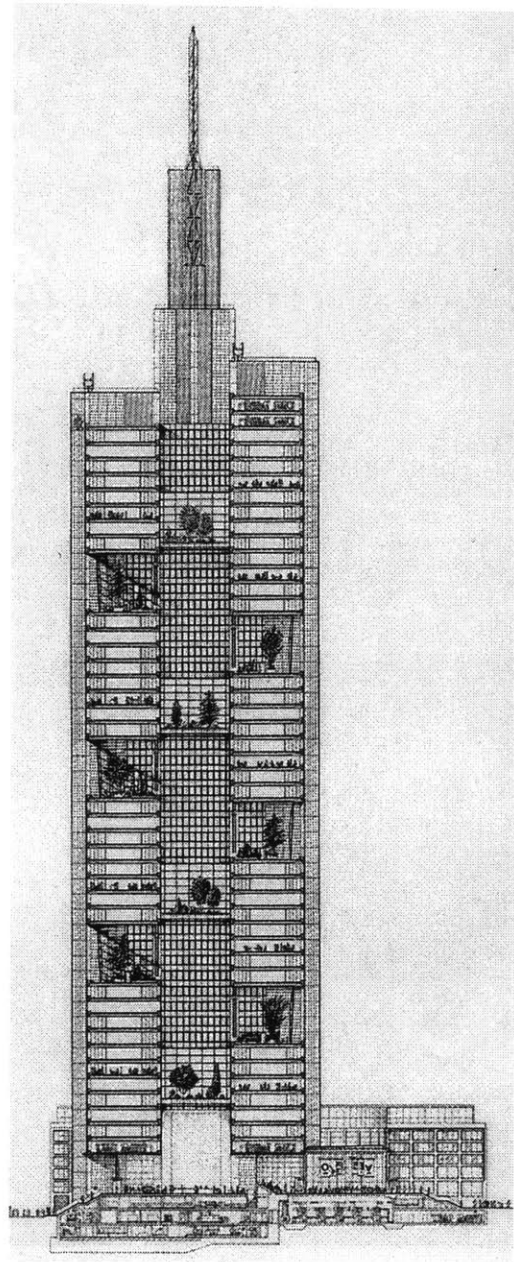

Commerzbank: Section.

Although the wall system is quite complex, many other less sophisticated techniques are employed in the Commerzbank Tower as well. For example, washrooms are supplied with only cold water sinks, and toilets use only gray-water from the cooling towers. Also, fire stairs and other less public spaces within the building are finished with recycled materials. These strategies, in combination with many others, contribute to the Commerzbank Tower's significance as one of the first ecologically friendly mega-structures in the world.

Kenneth Yeang's Mesiniaga Building and Foster's Commerzbank Tower are merely the beginnings of ecological design in large-scale architecture. They are both experimental in nature, and for this reason are not perfect solutions to environmentally responsive design. Sustainable design is in its infancy and will continue to evolve as technologies and understanding progress. Many more recent projects have since surpassed the efficiency and environmental positive impact of the Mesiniaga and Commerzbank projects, through new and more advanced technologies and strategies. Yeang and Foster continue to advance sustainable practices in their current work, and produce buildings

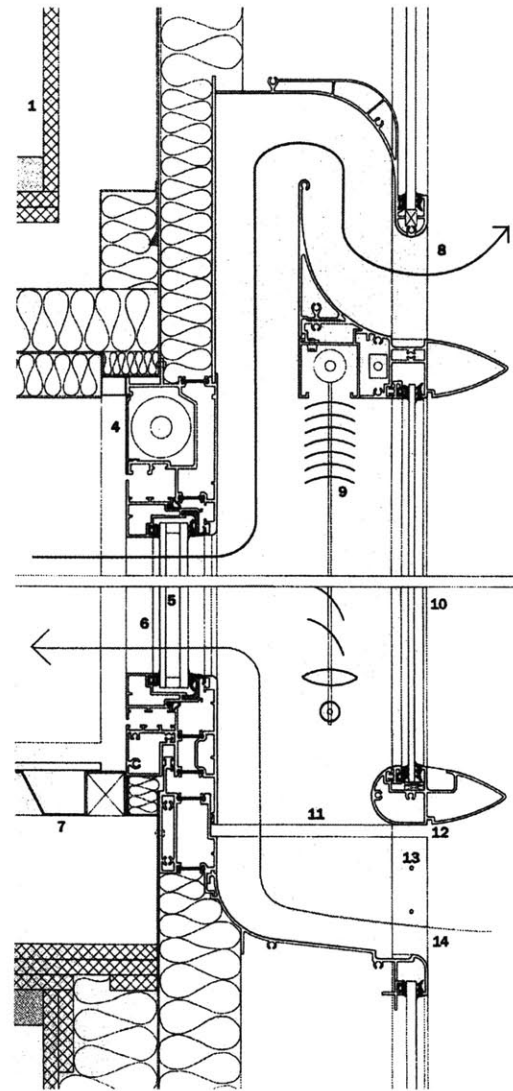

Commerzbank: Wall Section Detail.

that lead the way toward a new horizon of environmental responsibility.

The most recent high-rise building acclaimed for its environmentalism is the 1.6 million square foot Conde Nast Building at Four Times Square, by New York architects Fox & Fowle. Like Foster's Commerzbank before it, Four Times Square proclaims itself as the world's most advanced ecologically sensitive mega-structure. This Tower which is home of the Conde Nast publishing empire, is representative of the concerns and ambitions of countless other corporate headquarters being constructed at the turn of the twenty-first century. Although Four Times Square does employ a variety of cutting edge sustainable techniques that other recent high-rise buildings have yet to fully embrace, this project is indicative of a trend or redirection in large-scale buildings and developments toward ecological sensitivity.

Every element within the Conde Nast Building was considered for its environmental sensitivity, occupant health, and energy reduction strategies. The most publicized aspect of this building is its use of photovoltaic panels. The top eleven stories, on the south and east façades, of this 48 story Tower, are glazed entirely of energy generating, photovoltaic panels. Photovoltaics are

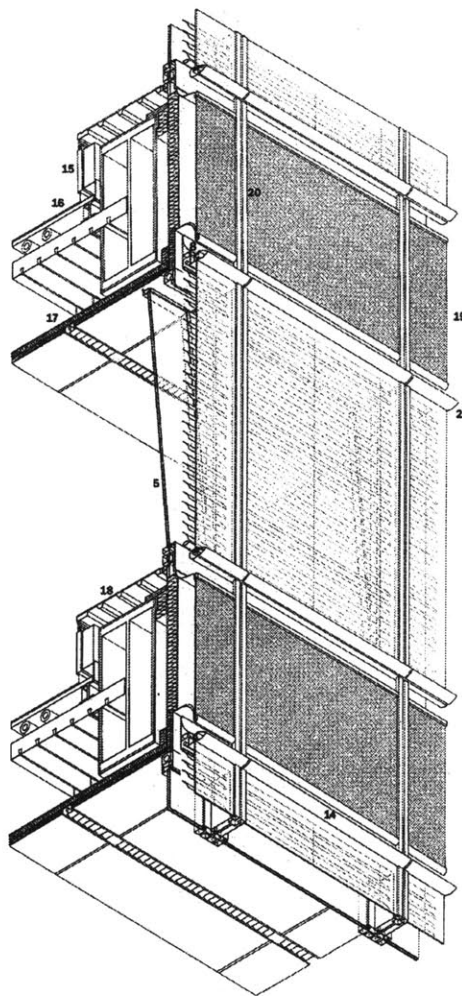

Commerzbank: Wall System.

based on semiconductor technology to produce electricity. They are modular, with no moving parts, generate no pollutants, and require only sunlight for fuel (Hart). Photovoltaics can be laminated directly into tempered glass and structurally glazed into a curtain wall. While in reality the 3000 square feet of thin-film, PV panels contribute only about one percent of the energy needs of Four Times Square, the significance resides in the experimental and scientific nature of the panels. Daniel Kaplan, design principal of Fox & Fowle, said that in the original design for the office tower, the entire east and south façades were considered for possible instillation of photovoltaic panels, however due to budget requirements, significant reductions had to be made. By glazing the entire east and south façades with PV, twenty-five percent of the buildings energy requirements could have been sufficiently met, although the economic payback of twelve years did not justify it. “That was not the point though”, explains Kaplan, “we consider this to be an in situ demonstration; we’ll study its impact over a long period of time” (Hart). This is an important point that Kaplan makes here. While the PV panels in this project contribute only a small amount to the over all energy reduction strategies, the implications for future projects and ad-

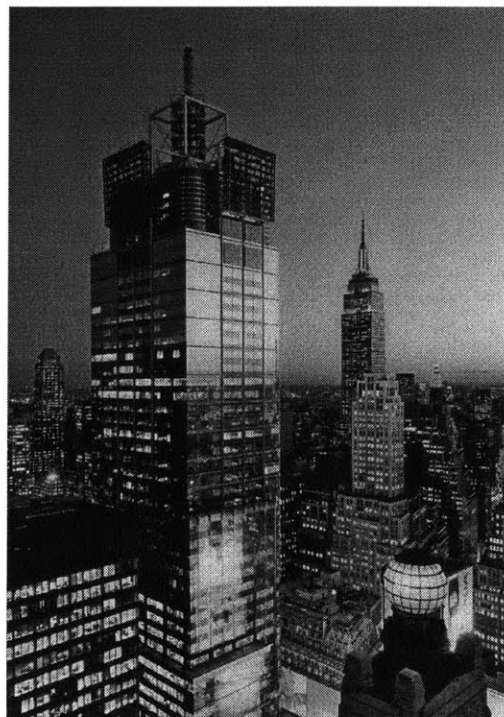

Conde Nast Building, Fox & Fowle, 2000.



Conde Nast Building, Fox & Fowle, 2000.

vancement in technology are enormous. In addition to the PV technology, the curtain wall system of the Conde Nast Tower incorporates conventional energy-saving features as well. Two types of double-glazed clear panels are used; a low-reflective glass on the lower floors and a higher reflectance glass, to cut down on solar heat gain, is applied to the upper floors (Stephens).

Air conditioning for the office building is supplied by CFC and HCFC-free absorption chillers fueled by clean burning natural gas. All HVAC equipment is digitally monitored with floor-to-floor variable-speed pumps, motors and fans, and fresh air is provided by state-of-the-art pollutant filtration systems. This air delivery system provides fifty percent more fresh air than is required by industry code. Also, additional exhaust shafts are situated throughout the building to further expel smoke, fumes, and heat.

To further reduce its negative impact on the environment, Four Times Square uses as many recycled and reusable materials as possible and employs prefabricated, modular construction techniques. The footings for the Tower are constructed entirely of concrete consisting of rock exhumed from the site that would otherwise have been dis-

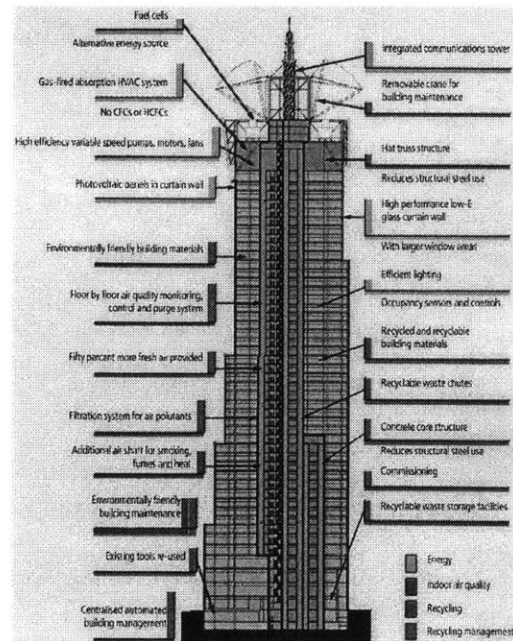

Conde Nast Building: Systems Diagram.

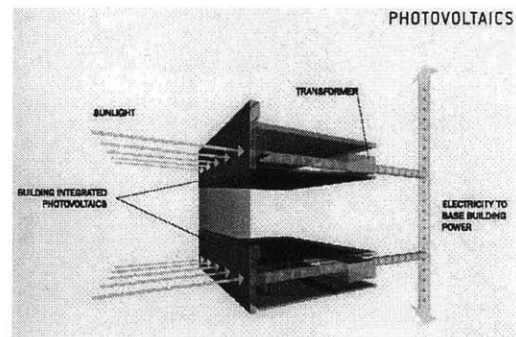

Conde Nast Building: Photovoltaic System Diagram.

carded to landfill. Much of the granite veneer on the north façade was also excavated from the site itself. Also, to limit the amount of costly, steel required for a structural frame, steel columns were placed inside of the concrete core shear walls. A steel hat-truss at the top of the building reduces lateral deflection, limiting further the amount of structural steel required within the building.

While this list of environmentally responsible design features in the Conde Nast Building are, most decidedly, numerous and noble in their intent, the actual energy savings are moderate. This fact is not intended to disparage this project in any way. The Conde Nast Building at Four Times Square is the most environmentally responsible high-rise building to date. However, this is only further proof of the enormous commitment required to one day produce a truly ecologically friendly mega-structure. This project is an experiment and working case study for others to follow and improve upon. Hillary Brown, an architect and managing editor of New York City's *Department of Design and Construction High Performance Building Guidelines* comments about the building that "It is important that we, as a culture, be socially responsible, take risks, and educate ourselves. The developers, architects, and all their consultants should take pride in this achievement. They are setting new standards".

We have thus far considered only the technological achievements of the Conde Nast building. It is important to note however, that this building is also a sophisticated design that responds well to its immediate surroundings and enhances the place in which it resides. Four Times Square savors its disposition as a hybrid design. It coalesces the crown and shaft of traditional skyscrapers while addressing the urban street-scape in a way that seamlessly dissolves into the surrounding signage of Times Square. The Tower combines a myriad of new-modernist elements, techno-constructivist imagery at the top, curved walls, and a watery reflective shaft, with traditional elements such as recessed windows and granite cladding (Stephens). The Tower is formally eclectic yet maintains a sense of balance and dignified presence. It is clear that the formal vocabulary of Four Times Square has been affected by its commitment to environmental strategies. And while it is not efficient enough to be considered a bioclimatic skyscraper in

Kenneth Yeang's definition of the term, it is a progression in that direction toward a new architectural typology.

Along with exterior and formal design considerations, there is emphasis placed on the quality of interior space. One of the primary concerns on the interior of the building were natural lighting strategies. Although the proportions of the site, dictated the footprint of the building to some extent, the architects limited the depth of the floor plate as much as possible by strategically stepping the structure back as much as possible to allow natural light to penetrate deep in to the building.

Now that we have examined the significance of one of the world's most environmentally sensitive mega-structures, the Conde Nast Building at Four Times Square, let us turn our attention to some other examples of projects and firms that are also directing their attention toward these pursuits. These next examples we will see may not necessarily be as environmentally responsive as the Conde Nast Building, however, in their collectiveness, they demonstrate an emerging trend or redirection in mega-structure construction.

Skidmore, Owings and Merrill is one of the largest and oldest architecture firms in the world. They are credited with pioneering the very idea of corporate architecture. SOM is also responsible for some of the twentieth century's largest and most celebrated skyscrapers. Their work traditionally has been on the cutting-edge of structural innovations. SOM has consistently synthesized the disciplines of architecture and engineering in their quest for technologically advanced designs. One example of SOM significant works is the John Hancock Insurance Company Building in Chicago. The Hancock Building uses an innovative exo-skeleton, cross-braced, structural frame as support, instead of massive concrete shear walls that were typical at its time of construction. This strategy allows the building to be very light. At only 29 pounds per square foot, the Hancock Building was the lightest skyscraper in existence when it was completed in 1974.

Skidmore, Owings and Merrill's most recognized work is probably the Sears Tower, also in Chicago. From the time of its construction in the late 1970's until 1999 it was the tallest building in the world. The Sears Tower advanced tube-structure technology in skyscrapers. Tube structures are considered to be the most efficient designs in counteracting wind loads. The Sears Tower structure consists of nine tubes, each seventy-five feet square. Much like the Hancock Building, this structure is very light. The tube-structure technology allows for minimal concrete shear wall mass at the core. Although rising over 1450 feet high, the Tower weight is just thirty-three pounds per square foot; a technological marvel at the time.

Today Skidmore, Owings and Merrill is advancing technology of a different sort. While still clearly interested in structural innovation, they are embracing environmental technologies as well. One of their most recent projects is the Xiamen Posts and Telecommunications Center in China. This design for a 63-story cylindrical office tower borrows extensively from Kenneth Yeang's research on sustainable mega-structures. Much Like Yeang's Menara Mesiniaga Building of 1992, this project uses a strategy of vertical, spiral-gardens to help sup-

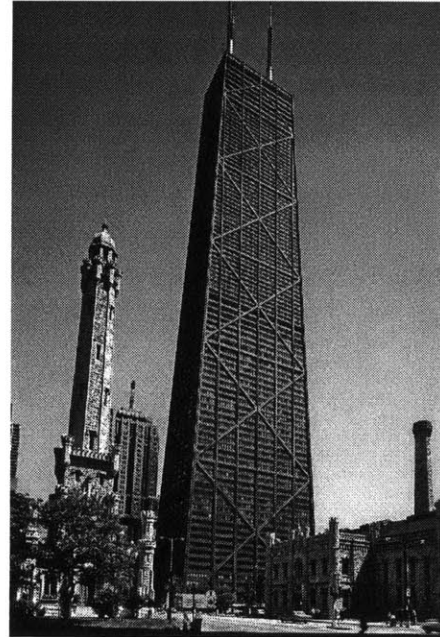

John Hancock Insurance Company Building, SOM, 1974.

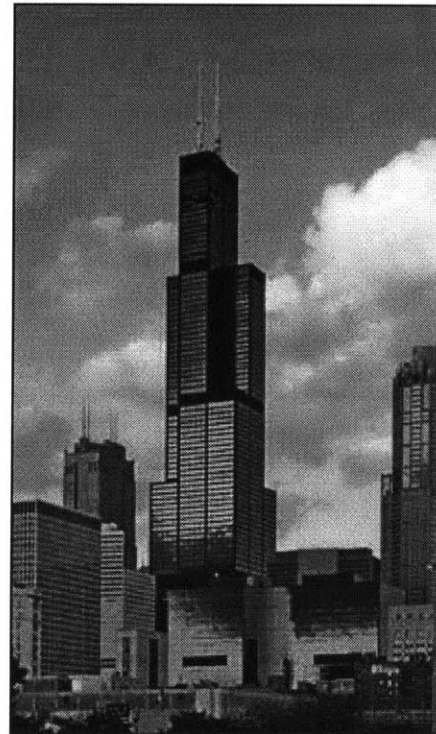

Sears Tower, SOM, 1977.

ply naturally ventilated, clean air to every floor of the tower. These 3-story high vertical-gardens are also a way to bring nature into the building and provide the occupants with pleasant common garden spaces. In order to provide as much natural lighting and ventilation as possible to as many offices as possible, the size and depth of the floor plates are limited. In an attempt to dissolve the mass of the building even further, and facilitate natural lighting strategies, the building will incorporate a series of cut-outs on every floor. This strategy will afford every office in the building the advantage of natural light. While this project does derive many of its design strategies from Yeang's earlier projects, the significance and difference is its scale. When the Xiamen Posts Tower is complete, it will be the first time the strategy of vertical spiral-gardens is utilized in such a massive building.

Another one of SOM's recent projects that utilizes sustainable technologies is the Manulife Financial Headquarters in Boston. Being only fourteen stories, this modest high-rise is quite different in nature than the 63-story Xiamen Tower previously discussed. The primary feature of this building, when completed in 2004, will be the 9-inch thick ventilation cavity curtain wall that

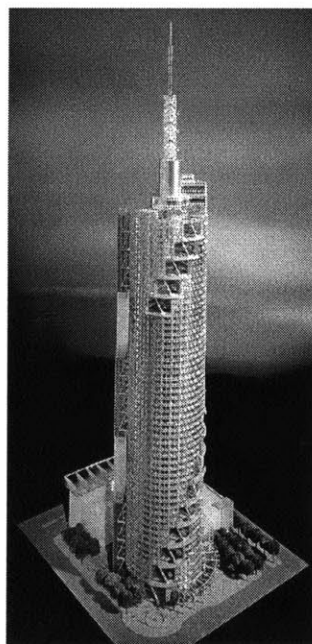

Xiamen Posts and Telecommunications Center,
SOM, 2005.

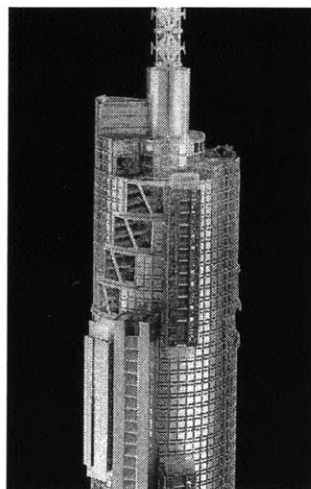

Xiamen Posts and Telecommunications Center,
SOM.

wraps three of its facades. This system, in essence, will help passively warm the building throughout the year by utilizing a void space within the curtain wall to heat air through solar radiation, and return it to the interior spaces. In warmer summer months, the building will benefit from natural ventilation with operable windows that will be controlled with sophisticated monitoring devices. Also, this project is reminiscent of Norman Foster's Willis Faber Building in that it incorporates a roof garden into its design to further passively insulate the structure.

Skidmore, Owings and Merrill's recent interests in sustainable technologies is not uncommon for a corporate firm. Actually, we have chosen to discuss their work because SOM is representative of many large international corporate architecture firms that have directed their attention toward these issues. However, corporate architecture firms are not the only ones gravitating toward energy efficiency and sustainable technologies in their recent large-scale constructions. Many smaller, high-design firms that are commissioned for large-scale projects are also addressing these issues. One such firm is Morphosis headed by architect Thom Mayne.

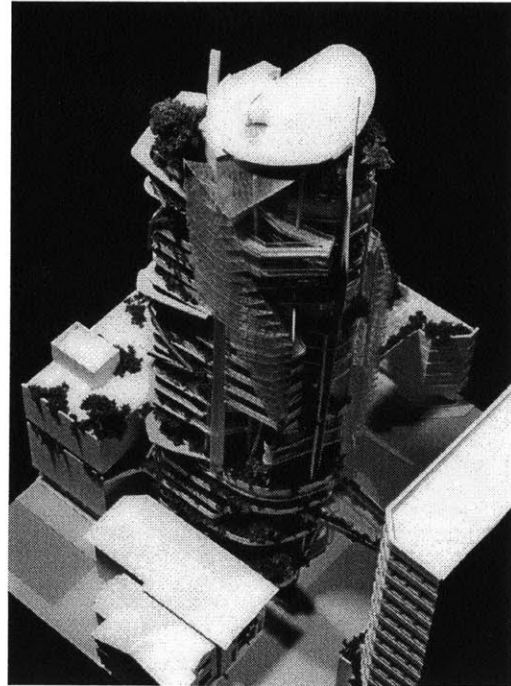

Editt Project, Unbuilt, Yeang.

Morphosis has traditionally been known predominantly for their avant-garde aesthetics and theoretical paper-architecture. However, recently their work has begun to address issues of energy efficiency through sustainable technologies. One project in particular where this is evident is the new Federal Office Building in San Francisco. Currently under construction and scheduled for completion in 2005, this project will be the most energy efficient, large building in the city of San Francisco. In this project, Morphosis has successfully synthesized their trademark cutting edge design aesthetics with sustainable technologies.

The primary efficiency strategy in this project is the natural ventilation system. Over seventy percent of the building will have no mechanical conditioning whatsoever. A revolutionary energy simulation program, developed by Berkeley Lawrence Labs, called EnergyPlus played a significant role in the design process of this project. Only because of this advanced software were the architects and engineers of the project able to design such an efficient passive system. This ventilation system will be operated by a high-tech building management system that monitors interior temperature and automatically opens and closes floor-

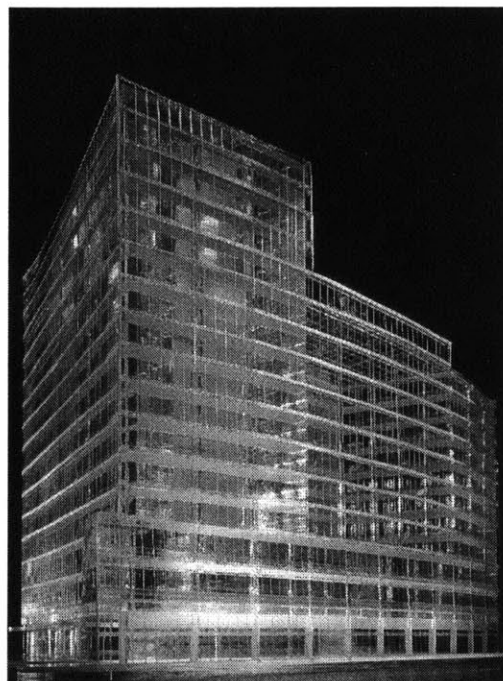

Manulife Financial Headquarters, SOM, 2004.

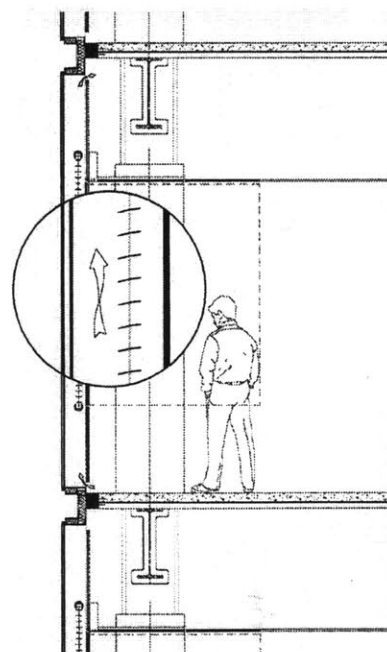

Manulife Financial Headquarters:
Ventilation Cavity.

level vents. Breezes will be allowed to enter the building on the northwest façade and will be vented through the southwest corner. To help facilitate this system, the entire building was designed around this ventilation strategy. Unlike most federal office buildings, this project will have as few interior walls as possible and all offices that require walls for privacy, or for security reasons, are located at the center of the building, not the perimeter which is standard office building layout. This design will enable the natural ventilation to function uninhibited and unrestricted by interior partitions while also allowing natural light to penetrate as deep into the structure as possible. Most noteworthy about this entire ventilation system is that, for the most part, it is a passive system. While it does make use of complex monitors and sensors to control the intake and exhaust of air, most air used to cool the structure is unconditioned, outside air. To further reduce heat gain, the ceilings are constructed of heavy-weight ceiling slabs to absorb and store heat, then dissipate it at night when the air is cooler and there are fewer occupants.

Similar to many other recent large-scale sustainable projects, the new eighteen-story San Francisco Federal Office Building will also

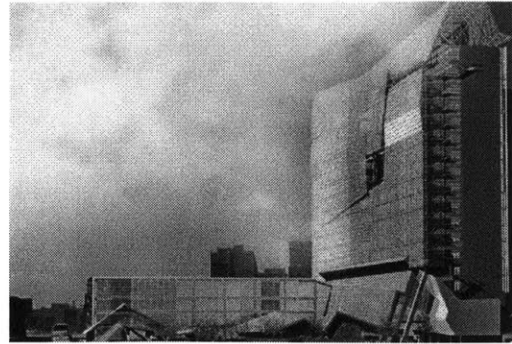

San Francisco Federal Office Building,
Morphosis, 2005.



San Francisco Federal Office Building,
Morphosis, 2005.

make use of a sky-garden. This feature will be notched into the eleventh through thirteen floors to provide, not only, a garden relaxation space for employees, but will also contribute to the natural lighting and ventilation strategies.

Pre-construction energy efficiency tests run using the EnergyPlus software project that this building will be fifty percent more efficient than other more typical, modest size high-rise towers of its kind. The savings is projected to be more than eleven million dollars over a fifteen year period. With an added construction cost of less than five percent of total budget, economically, the system clearly pays for itself. This statistic is said to have been one of the contributing factors in Morphosis being awarded this commission by the City of San Francisco.

Thom Mayne and Morphosis have clearly embraced sustainable technologies and practices in their work. The new U.S. Federal Building in San Francisco is a lucid example of this. They have embraced this new dimension into their work without compromising the bold design expression that made them famous. In our previous case studies of corporate firms we saw that Skidmore, Owings and Merrill could be considered a representative of countless other corporate architecture firms that have directed their attention toward sustainable technologies. In a similar manner, Morphosis too may be considered a representative of any number of small, high-design firms that have found it not only advantageous, but necessary to embrace such technologies that bring a new depth to their architecture.

The previous case studies we have seen thus far are all fine examples of the changing nature of architecture toward a concern for the environment. Although some of these projects are more advanced in their techniques and technologies than others, all of these works are linked through their similar intentions of energy efficiency and sustainable practices. Also, it may be argued that through these buildings, and others like them, a new architectural typology is emerging. The formal vocabulary of architecture is changing through the synthesis of sustainable technologies and design expression. This is certainly more prevalent in some case studies than in others. However, it is certain that all

of these buildings have been formally influenced, in some way, by their use of environmental technologies, whatever they may be. The formation of new typologies in architecture is usually a gradual occurrence, and as we have seen through our case studies, changes in established building typologies like skyscrapers, will be a subtle, gradual process as well. Sustainability in megastructures is still very much in its infancy. However, as technologies improve, expectations will be raised, and this new formal typology will continue to evolve in response.

One project that challenges all conventional high-rise typology is Norman Foster's design for the new Swiss Re Headquarters in London. The formal vocabulary of this design is clearly influenced by Foster's environmental concerns. This 40-story Tower, scheduled for completion in 2004, is another step in the sustainable evolution of high-rise buildings. The radical conical form of the Swiss Re Building defies all established norms associated with the traditional skyscraper. The form of the structure was developed to fully maximize its aerodynamic efficiency; to reduce direct solar heat gain; and to enhance the transparency of the facades. By making the form of the building more aerodynamic, Foster was able to limit

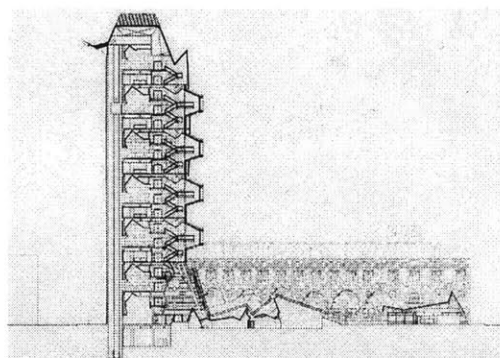

San Francisco Federal Office Building:
Section.

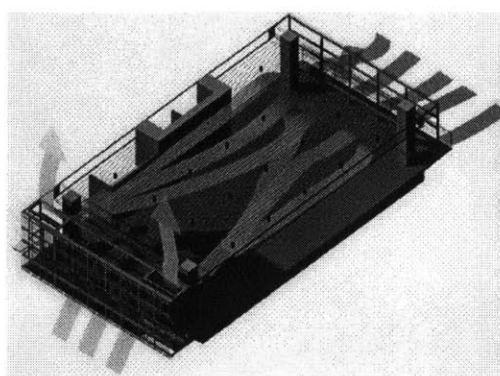

San Francisco Federal Office Building:
Ventilation Diagram.

the amount of material and structure necessary for structural stability. Also, the unusual form will deflect air flow around the building, not down toward the public plaza below, affording a more pleasant civic space.

The energy efficiency of the Swiss Re Headquarters project is, obviously, yet to be determined. Its environmental impact is projected to be substantially lower than other buildings of its size. However, the significance of this project with regard to our discussion is its radical formal proposition. As we discussed earlier in this chapter, Norman Foster was one of the early proponents of environmental responsibility in mega-structures. His Commerzbank Building in Frankfurt is an early example of this concern. The formal vocabulary of the Commerzbank project, however, is only minimally influenced by the environmental technologies integrated into the building; and rightfully so. It is to Foster's credit that the Commerzbank Building does not superficially, overly express its use of sustainable technologies simply for aesthetic purposes. The Swiss Re project is significant in that its form is truly unconventional because of its ecological position. This fact makes it an influential project in the emergence of a new architectural typology in large-scale



Swiss Re Headquarters, London, Foster, 2004.



Swiss Re Headquarters:
Environmental Strategies.

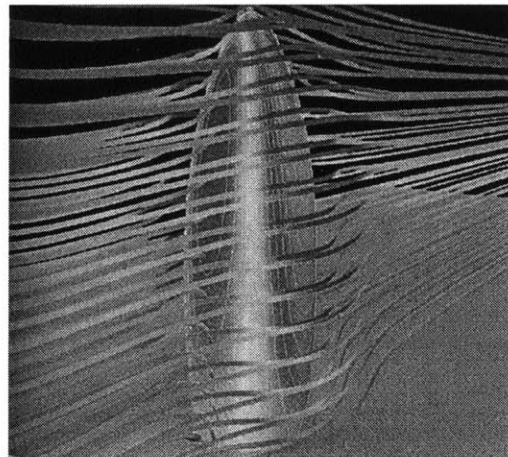

Swiss Re Headquarters: Wind Tunnel Test.

building based on sustainable technologies. Norman Foster said of the building “the aim of creating an environmentally responsible building with a natural economy of form, and a detailed understanding of the urban context, has been the only preoccupation of this practice. The Swiss Re is radical socially, technically, spatially, and architecturally”.

Chapter 6

Making an Argument

It may be argued that in recent years an unprecedented ecological awareness has taken hold, not only within the discipline of architecture, but throughout our society as well. No longer are we as a culture accepting of the long established traditions of buildings holding dominion over nature at all cost and without consequence. Today there is concern with bringing mankind and all things manmade into a benign harmony with our natural environment.

Architects can no longer be content with simply satisfying basic requirements of health, safety and welfare in their buildings. More esoteric investigations into the poetics of space, theoretical experimentation, or symbolic reference also are not enough. A new layer of expertise and understanding is now required of our discipline. The pursuits of design expression must now work in tandem with the advancement of sustainable technologies to achieve an architecture that responds in a positive and sensitive way to the environment in which it resides. Sustainable issues have become a significant participatory, yet not dominant, element within architectural design. It is the position of this thesis that there is a recent – and widespread - convergence of sustainable technologies and design expression that is occurring and affecting the entire discipline of architecture. The logical synthesis of technology and design is fundamentally altering not only what is built, but also how it is built. The physical implications of this convergence on contemporary architecture are that it is creating a new formal vocabulary never seen before. In many cases, a new typology is emerging.

While the change in process is also an integral part of this recent convergence of issues, this thesis has focused primarily on identifying the physical architectural evidence associated with it. The physical manifestation of the synthesis of sustainable technologies and design expression can be seen in a wide range of projects throughout the discipline and is bound by no aesthetic or formal category.

For decades, the pursuit of ecologically responsible architecture was relegated to the periphery of the discipline. Since the commencement of the Modern movement a century ago, the world of high-design has been predominantly preoccupied with formal expression. In spite of the shifting doctrines of movements such as Modern, Postmodern, High-Modern, Deconstruction, etcetera, the emphasis has remained on formal vocabularies. Recently however, new concerns associated with the negative impact of architecture on both the environment, and the health of its occupants, have emerged and found widespread appeal. These concerns have seemingly transcended all formal categorization, and are affecting architecture regardless of function, style, or theoretical position. Whereas once Sustainability was relegated to its own category, today it has become part of all categories.

Sustainability in the past was, arguably, a forced issue by those most committed to it. Purposefully locating themselves outside the architectural mainstream, proponents of sustainability took radical positions and pursued extreme solutions to environmental problems. A disenchanted discipline, and an unconvinced public, refused to embrace this movement. Today, however, environmental issues have become a relevant, participatory dynamic within architectural design. This is a departure from past sustainable movements in that it does not attempt to deny architectural expression or hold dominion over all other architecturally relevant issues.

By allowing sustainable technologies to both inform, and be informed by design expressions, a new vocabulary is emerging. This formal vocabulary is founded upon valid environmental and cultural responsibilities, which again is a departure from past movements that were many times founded exclusively on symbolic references, esoteric theory or formal semblance. Contemporary architecture has realized a balance between relevant architectural expression and its responsibility to nature.

It is important to acknowledge that these new ecological concerns within architecture are a response to a growing cultural awareness toward the well-being of the natural

environment. This cultural awareness, and shift in attitude, from just a decade ago, is the primary driving force behind this architectural convergence of design and environmental technologies. This shifting cultural attitude over the last decade has proved significant to the advancement of sustainable technologies within architecture. In the past, sustainable movements within architecture were seen as an attempt by the discipline to change a culture; today cultural attitude is changing the discipline. This is a fundamental difference and is primary to why contemporary sustainability has only recently found such ubiquitous acceptance.

Architects such as Norman Foster, Renzo Piano and Nicholas Grimshaw have been addressing sustainable issues in their respective works for decades. Their contribution to this field of study is unparalleled. Although the work of these three architects is quite different, there is a commonality in that all of their work allows building technologies to participate in a dialogue with their design intentions, to create a well defined aesthetic vocabulary. This formal aesthetic is based on concerns for energy efficiency, structural efficiency, and the minimal use of natural non-renewable resources. And although in the past, they have been catego-



Swiss Re Headquarters, Foster, 2004.

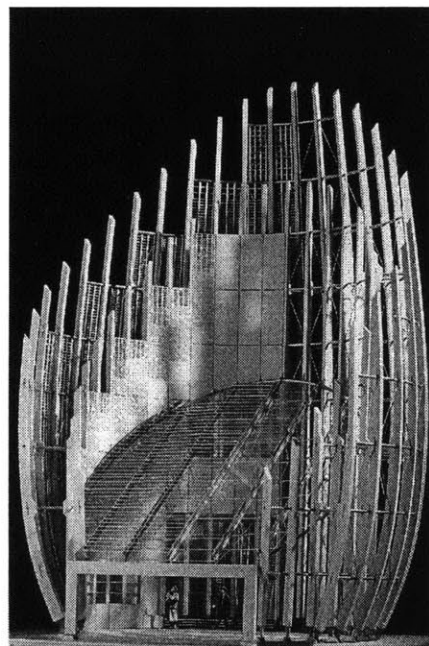

Tjibaou Cultural Centre, Renzo Piano, 1998.

rized as High-Tech or Eco-Tech, their work is simply an appropriate response to the environment in which it resides.

Some critics have argued that the work of Foster, Piano and Grimshaw openly parade the use of technology, strictly for aesthetic purposes. This is a superficial reading of their architecture. Environmental concerns are a significant factor in their projects. These concerns are so internalized and fundamental to their process, that they influence all aspects of the design process, and ultimately the final product. These environmental concerns coupled with the latest, and emerging technologies, inevitably translate into ecologically responsible architecture. To aesthetically or formally deny the intentions behind their work, or the technologies used to achieve their stated goals, would be fraudulent. And although some of their buildings achieve a greater success of sustainability than others, the significance resides in their intentions and the experimental nature of their work. Through these pursued intentions, and experimental use of emerging technologies, their work has become the epitome of the convergence of sustainable technologies and design expression.

As the discipline of architecture repositions itself with regard to sustainability and its responsibility to the environment, the work of Foster, Piano and Grimshaw has become highly influential and mimicked by countless others. It is significant to note that their work has recently been not only studied by a younger generation of architects and students concerned with sustainability, but also used as a paradigm by more established architects seeking to advance their own work with regard to these issues.

To appreciate the contribution's that Norman Foster, Renzo Piano and Nicholas Grimshaw have made to the convergence of technology and design within architecture, it is important to acquire an understanding of their work. Even a casual knowledge of this will prove valuable in realizing a greater understanding of the state of contemporary architecture. In chapter three of this thesis we discussed several works by Norman Foster that are indicative of a career devoted to environmental technologies synthesized with high design. Two of his earliest works, the Willis Faber and Dumas Head Office in

Ipswich (1975), and the Sainsbury Centre for the Visual Arts in Norwich (1978) are both very good examples of Foster's early intentions of energy and structural efficiency.

Most relevant to our discussion though, is Norman Foster's new German Parliament Building, the Reichstag in Berlin, recently completed in 2000. This project is representative of many Foster projects over the last decade. While not a new construction, this renovation is a lucid example of cutting-edge technologies and environmental systems working in concert with Foster's design ideals to create a superior work of architecture. It makes extensive use of alternate energy resources, heat recovery strategies, power generation technologies, combined with passive techniques to produce, what is calculated to be, an environmentally responsible building. The Reichstag is also an important project because of its high profile. It is representative of a country that is dedicated to environmentalism and technology. The new Reichstag had to illustrate these national values while simultaneously respecting the historic significance of the building.

It is valuable to note when discussing such recent work as the Reichstag- which has

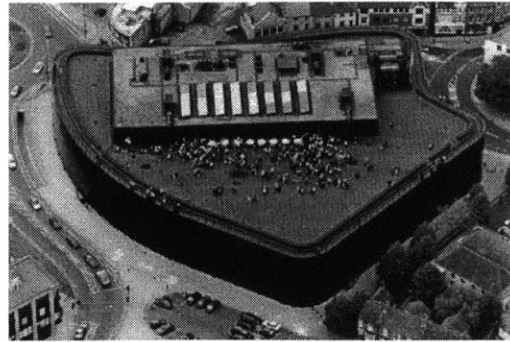

Willis Faber Building: Roof Garden, 1975.

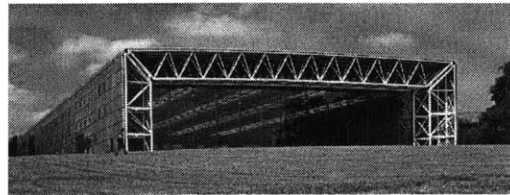

Sainsbury Centre, 1978.

ambitious environmental responsibility objectives- that scientific statistical data for many of these works is not yet available. Post occupancy studies either have not been conducted or are currently in process. Information such as actual energy efficiency calculations, natural ventilation data, etcetera, are currently nonexistent. However, while these facts and figures are important to the advancement of such systems, and to the future development of sustainable issues, it is important to note that the intentions are many times more important than the actual successes.

Nicholas Grimshaw has continuously been a leading advocate of sustainable technologies throughout his distinguished career. One of his most influential projects is the British Pavilion at the 1992 World Exposition in Seville, Spain. Although constructed over ten years ago, it remains a paradigm of environmental experimentation. This project was instrumental in illustrating that technological innovation could be more than simply formal window dressing. The British Pavilion was also seminal in that it proved that ecological concerns and high-tech architectural expression are not mutually exclusive (Slessor 88).

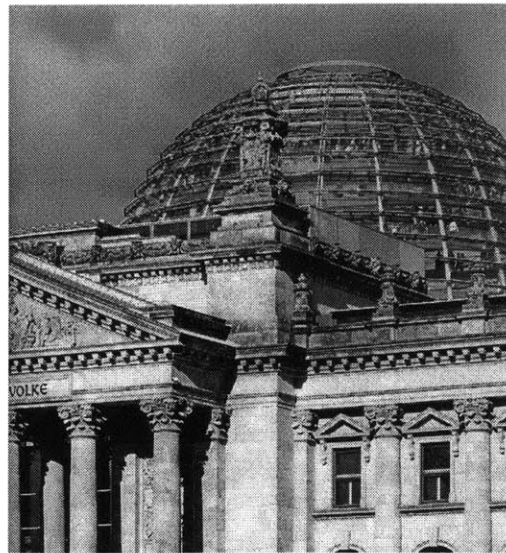

The Reichstag, Berlin, 2000.

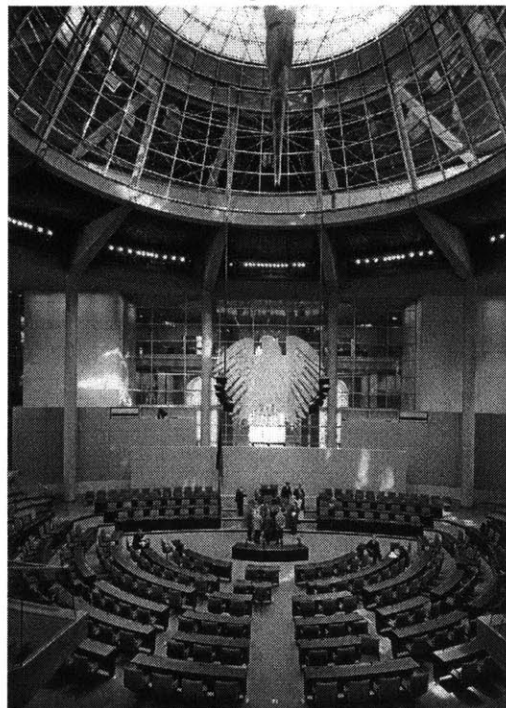

The Reichstag: Parliament Chamber.

The most ambitious design features of Grimshaw's British Pavilion is the giant water wall on the east elevation. Water gently cascades down a glazed wall and into a pool surrounding the building. Energy required to operate the water pumps for this feature are powered by solar panels installed on S-shaped roof shades. The physical and physiological cooling effects of moving water are well known in this region, and can be traced back to historic works such as the Alhambra and Cordoba. Grimshaw's design is not a new idea, it is simply an old idea implemented in a new way. This fundamental idea is what makes this project so appealing; ancient, passive sustainable techniques utilized in new, creative ways to achieve present day objectives. This wall is also an example of passive and active strategies working in tandem to accomplish an effect that neither could provide individually.

The respective works of Norman Foster and Nicholas Grimshaw are important case studies when exploring the convergence of sustainable technologies and design expression. It is important to remember however, that these architects, and those like them, who have been advocating these issues for many years are not necessarily responsible for the recent movement in architecture toward

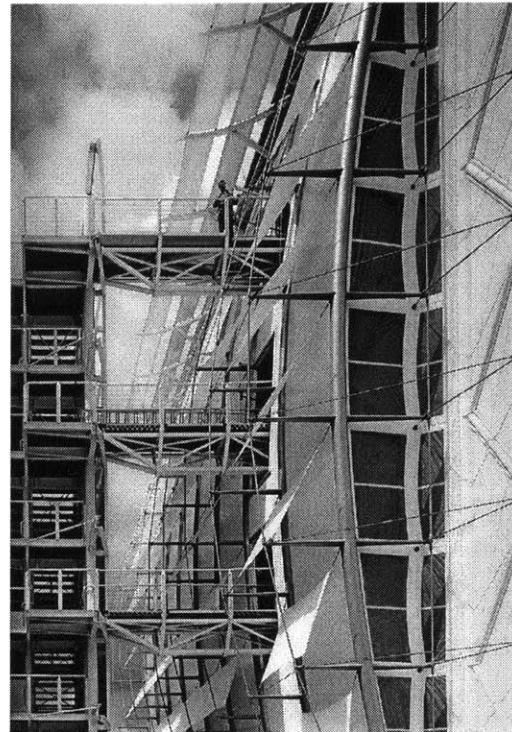

British Pavilion, World Expo; Spain, Grimshaw, 1992.

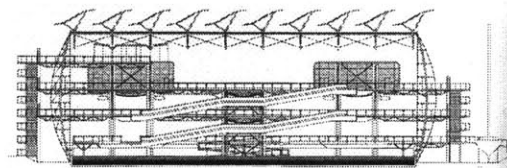

British Pavilion, World Expo; Section.

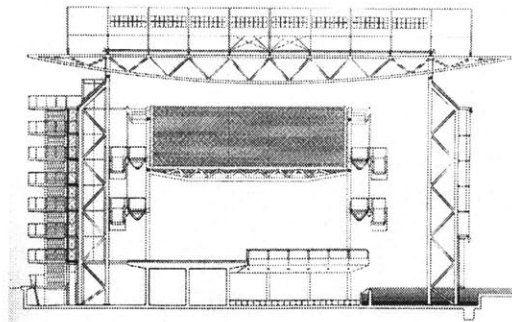

British Pavilion, World Expo; Section.

sustainability, but they certainly contributed to its advancement. For decades, Foster, Grimshaw and the handful of others like them, were certainly the exception to the rule. They were, most decidedly, ahead of the industry and correctly anticipated environmental concerns in architecture. Their work also now provides a plethora of case studies for the rest of the discipline to learn from, expand on, and improve upon.

In contrast to Foster and Grimshaw there are countless architects who have, only recently, addressed ecological issues in their work. Many of these designers were already well established, successful practitioners who, for one reason or another, found it necessary to embrace sustainable technologies. Within the context of this thesis it would be unfeasible, and un-necessary, to attempt to document all that have recently directed their attention to sustainable issues. Therefore, we have focused on one architect that may be considered representative of numerous other recent converts.

Richard Meier achieved great success early in his career while establishing a signature aesthetic. His work was renowned, and respected, throughout the world. Only then did he redirect his practice toward sustainable issues. Because of this extraordinary shift in position, we may consider Meier and his work exemplary of many others who have recently addressed such concerns. In the past, Richard Meier has been best known for his austere, pure-white forms and meticulous attention to architectural elements such as diagrammatic clarity, spatial complexity, geometric volumes, and the intricacy of light and shadow. Recently however, with his attention directed toward sustainability, a new layer of complexity has been added to his design intentions. Without compromising his signature design principles, he has incorporated environmental technologies into his architecture in a way that allows this new dimension to inform the overall formal vocabulary. This transformation of formal expression is significant to our discussion in that it clearly demonstrates how the synthesis of sustainable technologies with serious design can, and is, fundamentally altering architectural form.

The Smith House in Darien, Connecticut (1967), and the Douglas House in Harbor Springs, Michigan (1973), are two of Meier's seminal works that established him as a

preeminent architectural figure of his generation. These two works are exemplar of the archetypal Meier principles that made his early work so celebrated; strict modernist vocabulary, spatial complexity, diagrammatic clarity, and attention to light and shadow. To contrast these two projects with one of Richard Meier's more recent works, the Phoenix Federal Courthouse Building (1999), is extraordinarily revealing of his evolving architectural intentions.

The Phoenix Federal Courthouse is a formal departure from Meier's typical white-box vocabulary. More importantly than this though, is that the sustainable technologies and techniques utilized in the project are responsible for this departure. The grand semi-public atrium is the dominant feature of the building that all else is designed around. This glass hall is, conceptually, considered a transitional space between the severe desert environment of Phoenix, Arizona, and the fully conditioned work spaces within the building. Therefore, it is considered unnecessary to cool this space to the level that is required for offices and courtrooms. Because of this, the atrium is cooled using the adiabatic evaporation system. Adiabatic evaporation occurs when water absorbs heat energy from the surrounding environment

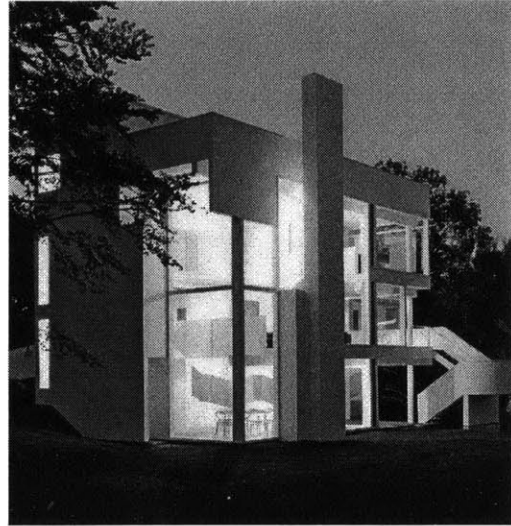

Smith House, Connecticut, 1967.

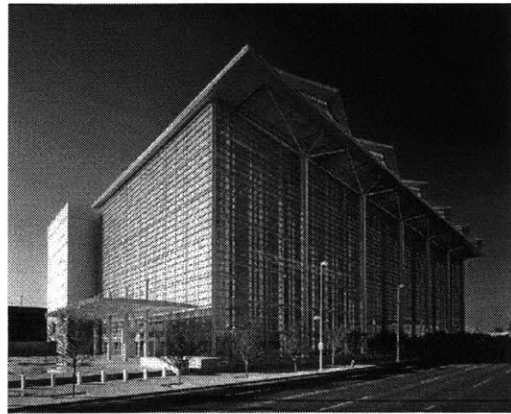

Phoenix Federal Courthouse, 2000.

and changes its state from liquid to gas. This mostly passive cooling system utilizes a fine spray of water that fully evaporates into the air achieving a 100% relative humidity. The air is passively moved through the atrium by a chimney effect created by careful positioning of air intake and outtake vents.

Although technically interesting, the adiabatic evaporative cooling system utilized in the Phoenix Federal Courthouse is not what is significant about this building. What is important is that without the use of this low-energy system, Meier would not have been able to incorporate the large, all glass, semi-public atrium into the design. By passively cooling the transitional atrium space, this large volume requires very little energy consumption and is therefore a feasible design element. If the sizeable atrium space had to be mechanically conditioned with conventional systems, it would have been extremely expensive and therefore inappropriate. In this instance, the sustainable technologies used in the building are not only related, but are responsible for, the formal vocabulary of the entire project.

Richard Meier's Phoenix Federal Courthouse is also a seminal work in that it represents a significant change in ideology regard-



Phoenix Federal Courthouse: Glass wall, interior view

ing interior conditioned space in buildings. Since the advent of the air-conditioner fifty years ago, people have subscribed to the idea that office buildings need to be cooled to sixty-eight degrees year round. This feeling was perpetuated by modernist doctrine that advocated the proverbial sealed glass box. The Phoenix Courthouse however, is a departure from this position. The glass atrium transition space is expected to be reasonably comfortable, but only about twenty degrees cooler than outside temperature. That means, that during summer months, when the temperature in Phoenix may reach 110 degrees, the atrium will be 90 degrees. For most of the year though, excluding the exceedingly hot summer months, the atrium would be between 60-85 degrees. This was considered acceptable for a transition space. This very idea represents an adjustment in expectations of what is acceptable for an interior conditioned environment. Yet another indication that our culture is becoming more cognizant of environmental issues and willing to adjust behavioral patterns and expectations accordingly.

Another, unlikely, project to integrate sustainable technologies into the overall design is Morphosis' Federal Building in San Francisco scheduled for completion in 2005. Like Meier's Phoenix Courthouse, this project will challenge conventional expectations regarding interior conditioned space. Seventy percent of this building will have no mechanical conditioning at all. The entire project was designed utilizing a sophisticated software program called EnergyPlus that simulates air flow and temperature throughout the building. It was established that most of the building could be reasonably cooled to between 60-75 degrees using only passive systems. This project is significant because the formal vocabulary of the design was heavily influenced by the use of digital software in pursuit of sustainable intentions and low-energy consumption.

Richard Meier and Morphosis are representative of a specific segment of the discipline of architecture that has recently acknowledged the importance of sustainable issues, and begun incorporating them into their designs. However, when attempting to identify this recent widespread convergence of sustainable technologies and design expression, it is important to consider a wider cross-section of the industry.

Sustainable issues have begun to affect all architecture firms, large and small alike. Firms such as Skidmore, Owings and Merrill that have a plethora of resources and capital to advance sustainable technologies are certainly beginning to advance this field through research and experimentation in many large-scale projects. However, environmental issues have taken hold in small firms as well. Although small firms or single practitioners, many times, do not have the resources to engage in high-tech research, they are advancing ecological design concerns through the exploration of low-tech, passive means. The foremost example of small-scale architecture that is heavily influenced by environmental concerns, is the work of Australian architect Glenn Murcutt. Although there can be few architectural similarities drawn between the massive, urban mega-structures of SOM and the sensitive, rural interventions of Glenn Murcutt, there are consistencies in their intentions. SOM, Murcutt, and countless firms in-between of varying sizes and categories, exhibit a commonality through their concern for environmental issues. These concerns are pursued, and achieved, in very different ways and, of course, vary in success.

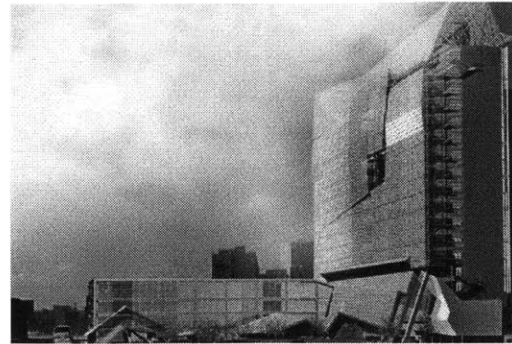

San Francisco Federal Office Building,
Morphosis, 2005.

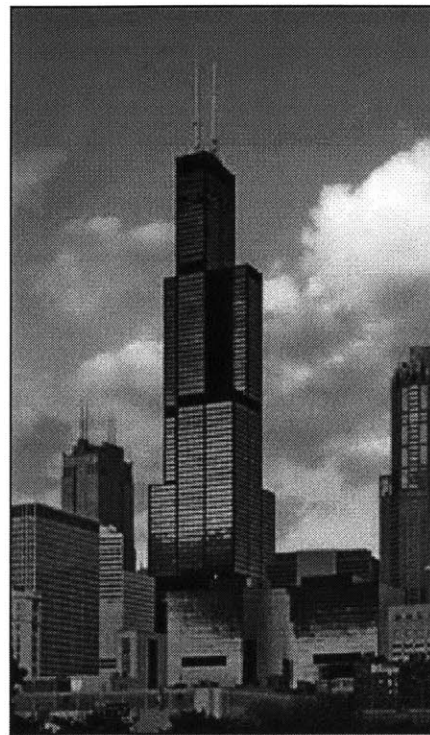

Sears Tower, SOM, 1977.

Glenn Murcutt has, for decades now, addressed environmental concerns and used these concerns to inform his architecture. Environmental issues in his work achieve such a level of integration with the overall design expression, that it is difficult, if not impossible, to distinguish which is which. While maintaining rather strict modern, minimal-rationalist principles, Murcutt's work realizes a remarkable relationship to the land and the environment. One of Murcutt's most recognizable works is the Magney House of 1984. In this rural intervention, it is quite evident how the climate patterns affect each façade in a subtly different way through its use of louvers and shading devices. The house delicately responds to natural light through orientation, façade treatments and use of materials. The terrain and structure exist in a way that benefits and celebrates the other. The Magney House, as with most other Murcutt projects, does not attempt to "blend-in" with its environment, yet it responds to every nuance of its surrounding gracefully.

The low-impact, passive techniques utilized in Murcutt's architecture achieve a level of synthesis with his modern-rationalist expression that blurs the distinction between design expression and function. This conver-

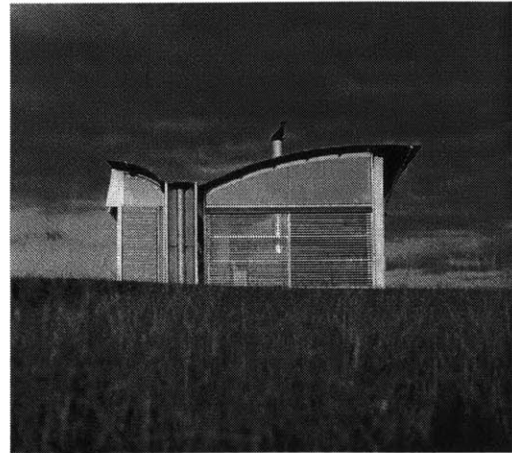

Magney House, Murcutt, 1984.

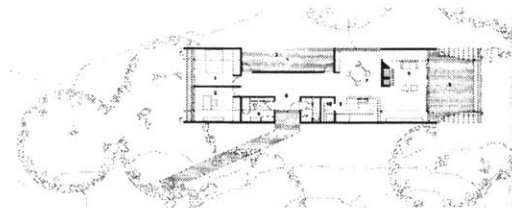

Ball-Eastway House: Plan. 1985.

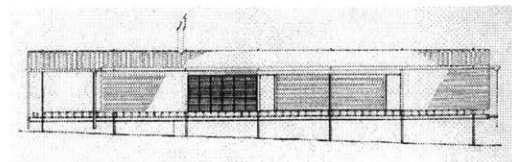

Ball-Eastway House: Elevation. 1985.

gence affords an overall quality of architecture. However, the way in which these passive environmental strategies are utilized is indicative of Murcutt's intentions, and expectations he has for his work. Much like Meier's Phoenix Federal Courthouse discussed earlier, Murcutt does not require that his houses be conditioned to a perfect 70 degrees year round. By passively cooling and naturally ventilating his projects, the occupants must expect, and accept, a range of comfort. In the summer months, the interior space may only be cooled to 80 degrees. This reality of expectations is an important part of Murcutt's work. This acceptance of comfort conditions allows the environmental strategies to be a participatory part of his designs, which in turn, affects the formal vocabularies of the projects. If Murcutt's projects were mechanically conditioned in a more conventional manner, the sustainable strategies would be less important to the overall design and hence, the projects would evolve differently. This reality of expectations is fundamental to passive cooling and ventilation strategies becoming more ubiquitous within architecture. By overcoming preconceived notions of what comfort is and what is required of interior conditioned space, our society will begin to build more environmentally efficient and friendly buildings of all scales.

The recent ubiquitous trend of mega-structures attempting to be more environmentally responsible is one that cannot be ignored when addressing the convergence of design expression and sustainability. As chronicled in chapter five of this thesis, most recent mega-structures being built or currently in various stages of design, are utilizing environmental technologies. The reasons for this are threefold. One, the potential monetary savings on reduced energy consumption for huge buildings is significant. Two, most large projects are built either by corporate entities or government agencies, who find it beneficial to be, or appear to be, environmentally responsible. And three - related to reason two - is that our contemporary culture is more concerned with environmental issues today than it was a decade ago. Society is beginning to dictate that architecture be more responsive to both the environment and to the health of its occupants.

This redirection toward sustainable technologies in the mega-structure is fundamentally changing the formal vocabulary of large-scale buildings. It may be argued that a new

architectural typology is emerging due to the recent attention to environmental concerns. Kenneth Yeang began addressing these issues in high-rise buildings twenty-five years ago while a graduate student at Cambridge University. His research, and architecture, has consistently been on the cutting-edge of the development of the emerging “Bioclimatic” skyscraper. His work has now begun to influence many other architects with similar intentions in pursuit of environmentally responsible high-rise structures.

Yeang’s research, development and implementation of the vertical spiral-garden in high-rise structures is one significant advancement in sustainable technologies that is fundamentally altering the formal vocabulary of high-rises. Yeang first utilized this strategy in his Menara Mesiniaga Building in 1992. Since then, this technique has been mimicked in some buildings, and interpreted slightly differently in others. However, in all projects where some version of the vertical spiral-garden is utilized, a new formal typology is emerging. Because this strategy must be fully integrated into the physical structure of a high-rise, it inevitably alters the vocabulary.

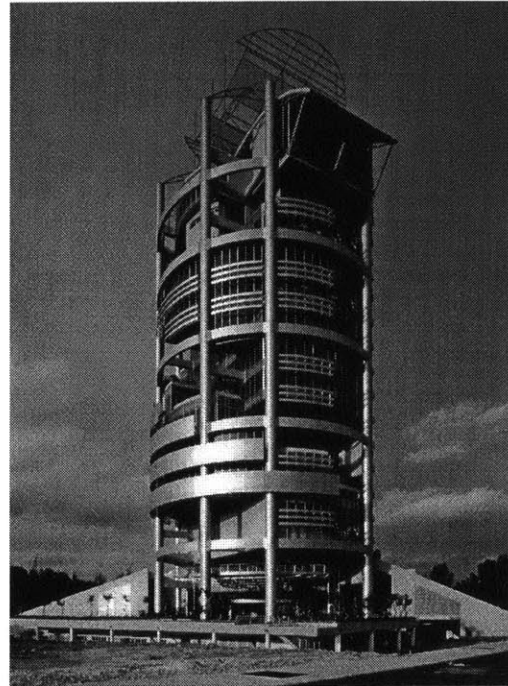

Menara Mesiniaga Building,
Hamzah and Yeang, 1992.

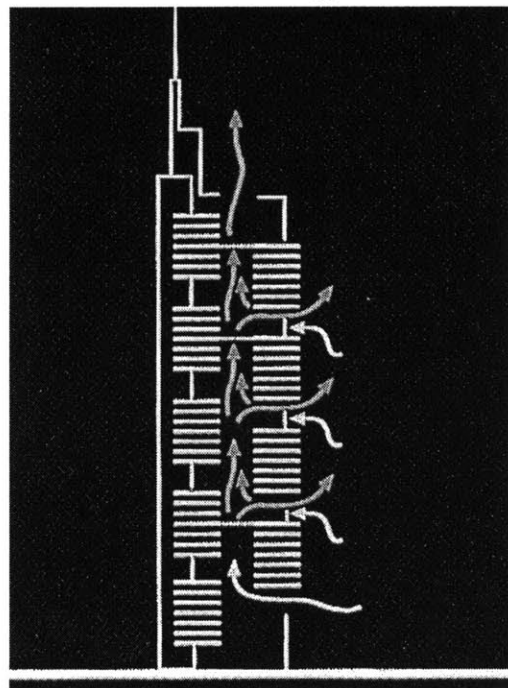

CommerzBank Building: Ventilation Diagram.

Possibly the world's first comprehensively sustainable high-rise was Norman Foster's CommerzBank Building in Frankfurt (1997). The main characteristic of this project is the 13 three-story high vertical gardens situated in a staggered manner throughout the building. This was the first attempt to utilize a variation of Yeang's vertical spiral-garden on a massive scale. The effect is has on natural ventilation and lighting requirements, contribute to the CommerzBank being one of the most energy efficient, environmentally friendly mega-structures in Europe. Aside from its success as an ecologically responsible structure, the CommerzBank Building is also an early step toward a new formal typology caused by the integration, and implementation, of sustainable technologies in high-rise buildings.

A high-rise building currently in the works is Skidmore, Owings and Merrill's Xiamen Telecommunications Centre in China. Scheduled for completion in 2005, this building will feature a vertical spiral-garden almost identical to those of Yeang's early projects. SOM has historically been associated with structural innovation in high-rise structures. Today, they are adding another dimension to their work by addressing sustainable technologies that inform both the

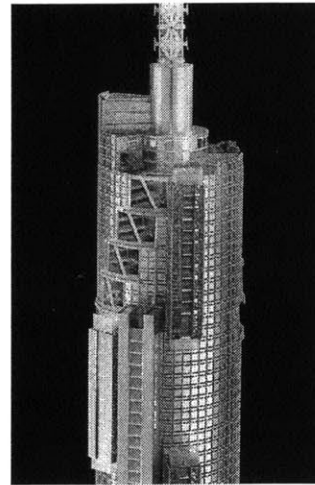

Xiamen Posts and Telecommunications Center, SOM, 2005.



Conde Nast Building, Fox & Fowle, 2000.

formal and aesthetic character of their architecture.

One recent high-rise project that cannot be overlooked when addressing the integration of sustainable technologies with design expression is the new Conde Nast headquarters at Four Times Square by New York architects Fox & Fowle (2000). This building is a perfect example of the seamless integration of technology and design. At Four Times Square it is difficult to decipher, or separate, the sustainable technologies of the building with its structural and enclosure systems. In many instances they are one and the same. One, of many, examples of this kind of integration, which can be observed in the Conde Nast Building, is its use of photovoltaic technology. In this instance, the photovoltaics are directly laminated into the tempered glass curtain wall, on the south and east facades, of the top eleven stories of this 48-story tower. The glass enclosure system and the photovoltaic technology are, literally, inseparable.

This combining of enclosure systems with energy generating technology in the Conde Nast Tower is similar to the strategies Glenn Murcutt utilizes in his small, rural projects in the Australian desert. Murcutt does not exploit sophisticated technologies like photovoltaic cells in his work, but he does merge enclosure systems with passive ventilation techniques. By creating facades entirely constructed of louvers to mediate wind and light, Murcutt fuses a variety of systems together to achieve desired objectives. Although these two examples – The Conde Nast Tower and the work of Glenn Murcutt – are, architecturally, completely different in scale and function, their similar integration of systems in pursuit of sustainable intentions, creates connectivity between these works.

This type of seamless integration of sustainable technologies with either enclosure systems or structural systems can be seen in many recent buildings. The merging of various building systems is what make today's implementation of sustainable technologies so different from the past. The sustainable movement of the 1970's witnessed a variety of radical solutions in pursuit of passive energy. One such project was the Baer House in Albuquerque, New Mexico (1972). Also known as the Drumwall-house, this project utilized a system of steel oil drums filled with water arranged on its west façade to

collect, store and eventually re-radiate heat to the interior of the house. This unconventional system was, more or less, built into a conventional house. This radical passive solar strategy was completely separate from both the enclosure system and the structural system. There was no integration or synthesis of systems. This lack of integration lends itself to being blatantly un-architectural and highly intrusive. The Baer House, along with its drumwall system, is very much representative of many passive solar experimentations of the 1970's. Though the designers of such systems had good intentions in pursuit of alternative energy, the lack of integration with established formal, aesthetic and functional architectural elements contributed to their lack of acceptance.

Today, sustainable technologies do not suffer from a lack of acceptance as they did thirty years ago. And although they are slow to be implemented due to lack of knowledge by the respective building and construction disciplines, sustainable technologies are not stigmatized as radical or extreme as they once were. Their level of sophistication and integration with other architectural elements is informing design expression in new and interesting ways. Through the implementation of such technologies a new architectural vocabulary is emerging.

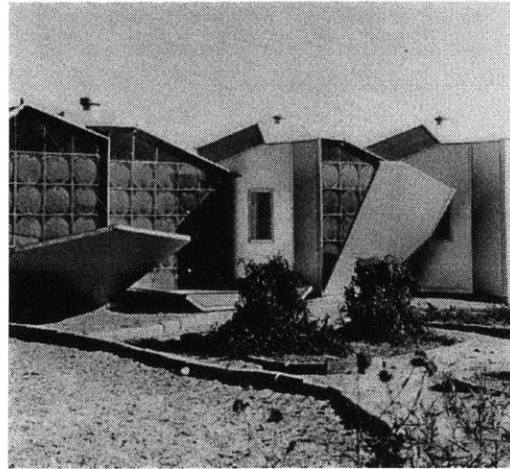

Baer House, Albuquerque, 1972.



Baer House, Albuquerque, 1972.

This emerging vocabulary may be seen across the discipline. As mentioned earlier, the use of sustainable technologies is affecting all firms regardless of size; from the large corporate firms like Skidmore, Owings and Merrill, to the single practitioner like Glenn Murcutt. However, the utilization of sustainable technologies is also affecting firms regardless of formal or aesthetic affinity. A commonality now exists between all architects and firms that pursue environmental responsibility in their work. For example, once the respective works of Richard Meier, Morphosis and Nicholas Grimshaw would have been categorized separately, according to formal and aesthetic appearance. But, today, because of their shared sustainable intentions, they may be discussed in concert due to their pursuit of common goals. Through the shared intentions of these different firms, we are able to establish a pattern within the discipline of architecture. A pattern of environmental concern that manifests itself in many types of buildings regardless of size, function, theoretical or stylistic position. And although their work remains formally, very different, the implementation of sustainable technologies into their respective design expressions is influencing the formal vocabulary of their work in interesting and stimulating ways.

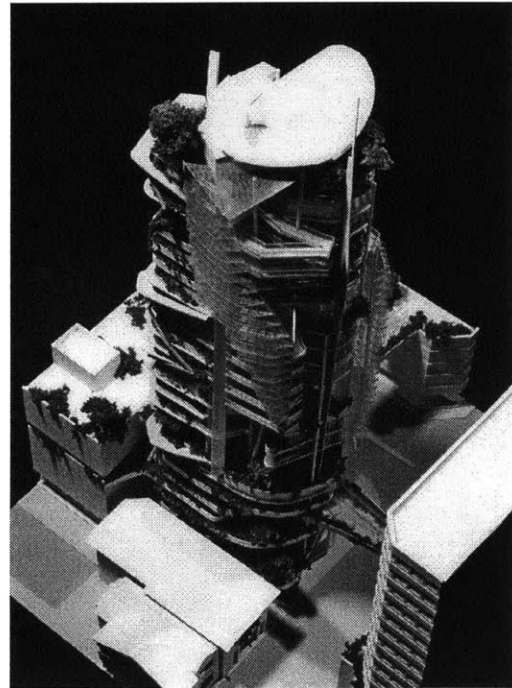

Editt Project, Unbuilt, Yeang.

This thesis has postulated that through the convergence of sustainable technologies and architectural design expression, a new formal vocabulary is emerging; a vocabulary that is creating not only a new aesthetic and formal expression, but also new spatial situations never before realized in architecture. The case studies to support such a hypothesis are limitless. Because of this fact, we have attempted to address select buildings representative of a wide cross-section of the discipline. Buildings that in one form or another, are indicative of a re-direction within the discipline toward such a convergence. It is clear that the formal vocabulary of architecture is changing because of the widespread integration of sustainable technologies. With the rapid advancement of building technologies in general, this convergence will only continue. As sustainable technologies continue to improve and knowledge of their use becomes more ubiquitous, the line between design expression and environmental technologies will continue to blur. Renzo Piano, one of today's most creative and successful practitioners committed to advancing sustainable technologies in architecture, said at a lecture he gave at MIT in 1997 "It should be practically impossible to trace the limit between arguments that are typical of an artistic ac-



British Pavilion: East Facade.



Phoenix Federal Courthouse: Atrium.

tivity (giving expression, giving shape) and arguments that belong to the world of science and technology (wind, force, turbulence, security). The frontier between these elements should be impossible to distinguish". Piano's statement eloquently speaks of the convergence of sustainable technologies and design expression that this thesis has attempted to identify within the discipline of architecture. Piano is one of the few architects who has correctly anticipated this widespread movement in architecture toward sustainable concerns.

While significant advancement has been made over the last decade with regards to sustainable issues in architecture, it is undeniable that significant work is left to be done. Many of the buildings chronicled in this thesis are significant for their progression and advancement of environmental issues; however, not one of these works is an absolutely sustainable project. Meticulous, scientific and empirical testing of current experimental sustainable strategies needs to be conducted in order to advance and improve their usefulness. And while the implementation—and success—of sustainable technologies in architecture remains limited at times, it may be argued that the intentions behind the work are more important than the tan-

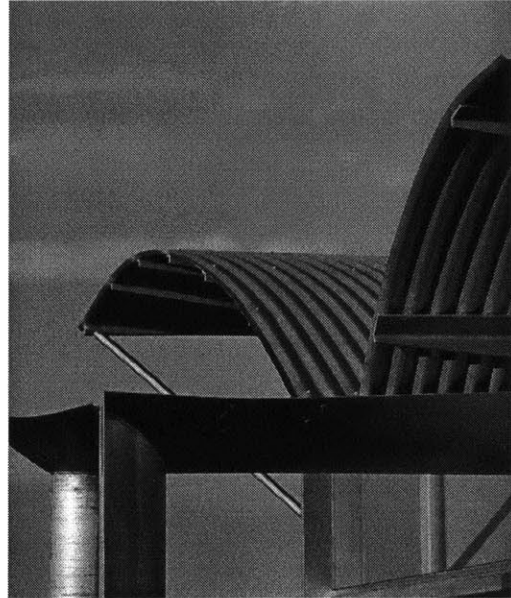

Magney House, Murcutt, 1984.

gible achievements of current technologies. If the discipline of architecture persists with intentions toward environmental responsibility, inevitably, the built environment will approach a level of success tantamount to its objectives. And while this may require years—if not decades—of continued experimentation and research, the eventual maturation of this field will produce buildings of ecological responsibility. Hence, the intentions toward sustainability, arguably, are more important than the current and recent successes or failures.

Progress and change within the discipline of architecture is slow and the realization of ubiquitous sustainable architecture may not be attainable in the near future. This sobering fact is not a deterrent however, to a discipline—influenced by a culture—that now understands the necessity and responsibility that architecture has to the environment and to mankind. As stated earlier in this thesis, more is expected of architecture and architects today; a new layer of understanding and expertise is required. This discipline has a newfound responsibility that is affecting the built environment as we know it, for the better. This responsibility will likely continue and influence the work of generations to come. Charles Eames once said that “there is no greater call for an architect than to be in the service of mankind”. Those that pursue the convergence of sustainable technologies and design expression, for the betterment of the environment, and the well-being of all mankind, will fulfill this call.

Bibliography

Chapter 2

AIA Research Corporation under Grant from the U.S. Department of Housing and Urban Development. A survey of Passive Solar Building. New York, 1978

Baldwin, J. Bucky Works: Buckminster Fuller's Ideas for Today. New York: Wiley Press, 1996

Cook, Jeffrey. Award-Winning Passive Solar Designs. New York: McGraw-Hill Book Company, 1984

Domin, Christopher, and King, Joseph. Paul Rudolph: The Florida Houses. New York: Princeton Architectural Press, 2002

Frampton, Kenneth. Modern Architecture: A Critical History. London: Thames and Hudson Ltd, 1997

Hatch, Allen. Buckminster Fuller: At Home in the Universe. New York: General Publishing Company, 1974

Kenner, Hugh. Bucky: A Critical Guided Tour of Buckminster Fuller. New York: Morrow and Company, 1973

Menocal, Narciso, G. Keck and Keck Architects. Madison, Wisconsin: Litho Productions, Inc, 1980

Watson, Donald. Designing and Building a Solar House: Your Place in the Sun. New York: The Village Press, Inc, 1977

Chapter 3

Banham, Reyner, and Butt, Loren. Foster Associates. London: RIBA Publications Ltd., 1979

Evans, Barrie. "Full of Environmental Promise, Energy-saving was only one of several design concerns for Berlin's Reichstag, but its promise appears to be high". The Architect's Journal. February 25 1999

Foster, Norman. Foster Catalogue. Munich, London, New York: Prestel, 2001

Foster and Partners. Reichstag Berlin. Berlin: Aedes 1994.

Gili, Gustavo, ed. Norman Foster: Works and Projects 1981-1988. London: Quadens Monografias, 1989

Hughes, Henry, ed. British Architecture Today: Six Protagonists. Milan: Electa, 1991

Jenkins, David. Rebuilding the Reichstag. New York: The Overlook Press, 1999

Lambot, Ian, ed. Norman Foster: Buildings and Projects of Team 4 and Foster Associates 1964-1973. London: Watermark Publications UK Limited, 1991

Nakamura, Toshio, ed. Architecture and Urbanism Extra Edition Norman Foster. Tokyo: A+U Publishing, 1988

Pawley, Martin. Norman Foster: A Global Architecture. New York: Universe Publishing, 1999

Quantrill, Malcolm. The Norman Foster Studio: Consistency through Diversity. London, New York: E & FN Spon an imprint of Routledge, 1999

Schulz, Bernhard. The Reichstag: The Parliament Building by Norman Foster. Munich, London, New York: Prestel, 2000.

Sudjic, Deyan. Norman Foster, Richard Rogers, James Sterling: New Directions in British Architecture. London: Thames and Hudson, 1986

Chapter 4

- Barreneche, Raul. "Meier's White Turns Green". Architecture Feb. 1996: 131-139
- Barreneche, Raul. "U.S. Courthouse". Architecture May 1996: 118-121
- Blaser, Werner, ed. Richard Meier: Building for Art. Berlin: Birkhauser Verlag, 1990
- Filler, Martin. "The Big Rock Candy Mountain: Getty Center, Los Angeles." AV Monografias May-June 1998 58-75
- Flagge, Ingeborg, ed. Richard Meier in Europe. Berlin: Ernst in Sohn, 1997
- Frampton, Kenneth. Masterworks: The Twentieth Century House. New York: Rizzoli, 1995
- Gionannini, Joseph. "Modern or Contemporary?" AV Monografias May-June: 12-20
- Green, Lisa, ed. Richard Meier: Barcelona Museum of Contemporary Art. Japan: The Monacelli Press Inc. 1997
- Green, Lisa, ed. Richard Meier Architect. Los Angeles: Monacelli Press. Inc. 1999
- Green, Lisa, ed. Richard Meier Architect 1985-1991. New York: Rizzoli, 1991
- Ockman, Joan, ed. Richard Meier Architects 1964-1984. New York: Rizzoli, 1984
- Rowe, Colin, ed. Five Architects. New York: Wittenborn & Company, 1972
- Rudolph, Karen. "Richard Meier: Light as a Transient Medium". Architectural Design. March-April 1997: 55-60
- Sainz, Jorge. "Meier in America". AV Monografias. May-June 1996: 4-11
- Smith, Peter. Sustainability at the Cutting Edge: Emerging technologies for low energy buildings. Cornwall UK: Architectural Press, 2003

Sorkin, Michael. "Come and Getty: Archmodernist Meier's work takes an unexpected turn toward kitsch". Metropolis June 1998: 45-47.

Summer, Verano. "Barcelona's Two Souls". AV Monografias. May-June 1996: 208-211.

Chapter 5

Conway, Donald, ed. Human Response to Tall Buildings. Pennsylvania: Dowden, Hutchinson & Ross, Inc. 1977

Davidson, Adam. "Thom Mayne's Moment". Metropolis March 2003: 83-87

Edwards, Brian, ed. "Green Architecture". Architectural Design. 2001 July

Foster, Norman. Foster Catalogue 2001. Munich: Prestel Verlag, 2001

GA Document. "Norman Foster: Swiss Re Headquarters". 2000 April n.61: 16-19

Gissen, David, ed. Big & Green. New York: Princeton Architectural Press, 2003

Hart, Sara. "Guess Who's Going Green". Architecture. 1998 August: 116-119

Jackson, Nicola. "A Life Less Ordinary". World Architecture. 2001 October: 42-43

Jones, David. "Sustaining an Argument". World Architecture. 1999 March: 100-114

Pepchinski, Mary. "Commerzbank Reinvents the Skyscraper". Architectural Record. 1998 January: 69-79

Platter, Dave. "The Big Green Apple". Urban Land. 2000 February: pg. 41

Richards, Ivor. "Skyscrapers for the Future". Architects' Journal. 1997 March 6: 28-29

Richards, Ivor. "Tropic Tower". Architectural Review. 1993 February: 26-31.

Salvadori, Mario. Why Buildings Stand Up. New York: W.W. Norton & Co, Inc., 1990

Space Design. Bioclimatic Skyscrapers. 1994 March.

Stephens, Suzanne. "Fox & Fowle creates a collage in Four Times Square". Architectural Record. 2000 March: 91-98.

Taylor, David. "Foster's City tour de force". The Architects' Journal. 29 July, 1999: 5-7

Wang, Wilfried, ed. SOM Journal 1. Germany: Hatje Cantz, 2001

Whyte, Andy, ed. Skidmore, Owings and Merrill LLP: Architecture and Urbanism 1995-2000. Hong Kong: The Images Publishing Group, 2000

Yeang, Kenneth. Hamzah & Yeang: Bioclimatic Skyscraper. London: Ellipsis London Limited, 1994.

Yeang, Kenneth. The Green Skyscraper. Munich: Prestel Verlag, 1999.

Yeang, Kenneth. Service Cores: Detail in Building. Italy: Wiley-Academy, 2000

Chapter 6

Amery, Colin. Architecture, Industry and Innovation: The Early Work of Nicholas Grimshaw & Partners. London: Phaidon, 1995.

Drew, Philip. Leaves of iron: Glenn Murcutt, Pioneer of an Australian Architectural. Pymble, NSW: Angus & Robertson, 1991.

Farrelly, E. M. Three Houses: Glenn Murcutt. London: Phaidon, 2002.

Fromonot, Françoise. Glenn Murcutt: Buildings and Projects. New York: Whitney Library of Design, 1995.

Moore, Rowen, ed. Structure, Space and Skin: The Work of Nicholas Grimshaw & Partners. London: Phaidon, c1993.

Murcutt, Glenn. Glenn Murcutt: A Singular Architectural Practice. Australia: Images Pub. Group, 2002.

Pawley, Martin. Norman Foster: A Global Architecture. New York: Universe Publishing, 1999

Pearman, Hugh. Equilibrium: the work of Nicholas Grimshaw & Partners. London: Phaidon, 2000.

Slessor, Catherine. Eco-Tech: Sustainable Architecture and High Technology. London: Thames & Hudson Ltd, 1997.