

ESTIMATION AND ANALYSIS OF  
NONLINEAR STOCHASTIC SYSTEMS

by

Steven Irl Marcus

B.A., Rice University  
(1971)

S.M., Massachusetts Institute of Technology  
(1972)

SUBMITTED IN PARTIAL FULFILLMENT OF THE

REQUIREMENTS FOR THE DEGREE OF

DOCTOR OF PHILOSOPHY

at the

MASSACHUSETTS INSTITUTE OF TECHNOLOGY

May, 1975

Signature of Author.....  
Department of Electrical Engineering, May 19, 1975

Certified by...  
Thesis Supervisor

Accepted by .....  
Chairman, Departmental Committee on Graduate Students



ESTIMATION AND ANALYSIS OF  
NONLINEAR STOCHASTIC SYSTEMS

by

Steven Irl Marcus

Submitted to the Department of Electrical Engineering on May 19,  
1975 in partial fulfillment of the requirements for the Degree  
of Doctor of Philosophy

ABSTRACT

The algebraic and geometric structure of certain classes of nonlinear stochastic systems is exploited in order to obtain useful stability and estimation results. First, the class of bilinear stochastic systems (or linear systems with multiplicative noise) is discussed. The stochastic stability of bilinear systems driven by colored noise is considered; in the case that the system evolves on a solvable Lie group, necessary and sufficient conditions for stochastic stability are derived. Approximate methods for obtaining sufficient conditions for the stochastic stability of bilinear systems evolving on general Lie groups are also discussed.

The study of estimation problems involving bilinear systems is motivated by several practical applications involving rotational processes in three dimensions. Two classes of estimation problems are considered. First it is proved that, for systems described by certain types of Volterra series expansions or by certain bilinear equations evolving on nilpotent or solvable Lie groups, the optimal conditional mean estimator consists of a finite dimensional nonlinear set of equations. Finally, the theory of harmonic analysis is used to derive suboptimal estimators for bilinear systems driven by white noise which evolve on compact Lie groups or homogeneous spaces.

THESIS SUPERVISOR: Alan S. Willsky  
TITLE: Assistant Professor of Electrical Engineering

## ACKNOWLEDGEMENTS

It is with great pleasure that I express my thanks to the many people who have helped me in innumerable ways during the course of this research.

First I wish to convey my sincere gratitude to my thesis committee:

Professor Alan S. Willsky, my good friend and thesis supervisor, who provided the motivation for this work and gave me the encouragement and advice I needed throughout this research;

Professor Roger W. Brockett who aroused my interest in algebraic and geometric system theory and provided many valuable ideas and insights;

Professor Sanjoy K. Mitter whose guidance and discussions (both technical and non-technical) have been very important to me.

I also wish to thank Professor Jan C. Willems, my Master's thesis supervisor, who was an important influence on my graduate studies.

I wish to express my gratitude to Dr. Richard Vinter for his friendship and for many valuable discussions. Thanks are also due to my other colleagues at the Electronic Systems Laboratory, especially Wolf Kohn and Raymond Kwong, for many stimulating discussions, and to my friends and roommates for making the last four years more enjoyable.

I wish to thank Ms. Elyse Wolf for her excellent typing of this thesis and for her friendship. I also thank Mr. Arthur Giordani for the drafting.

Finally I wish to thank my parents, Peggy and Herb Marcus, for their love and encouragement over the years.

I am indebted to the National Science Foundation for an N.S.F. Fellowship which supported the first three years of my graduate studies, and the

Electrical Engineering Department at M.I.T. for a teaching assistantship for one semester.

This research was conducted at the M.I.T. Electronic Systems Laboratory, with full support for the last semester extended by AFOSR.

TABLE OF CONTENTS

	PAGE
ABSTRACT	2
ACKNOWLEDGEMENTS	3
LIST OF FIGURES	8
CHAPTER 1 INTRODUCTION	9
CHAPTER 2 BILINEAR SYSTEMS	16
2.1 Deterministic Bilinear Systems	16
2.2 Stochastic Bilinear Systems	20
CHAPTER 3 STABILITY OF STOCHASTIC BILINEAR SYSTEMS	27
3.1 Introduction	27
3.2 Bilinear Systems with Colored Noise-- The Solvable Case	29
3.3 Bilinear Systems with Colored Noise-- The General Case	34
CHAPTER 4 MOTIVATION: ESTIMATION OF ROTATIONAL PROCESSES IN THREE DIMENSIONS	40
4.1 Introduction	40
4.2 Attitude Estimation with Direction Cosines	41
4.3 Attitude Estimation with Quaternions	47
4.4 Satellite Tracking	51
CHAPTER 5 FINITE DIMENSIONAL OPTIMAL NONLINEAR ESTIMATORS	53
5.1 Introduction	53

	PAGE
5.2 A Class of Finite Dimensional Optimal Nonlinear Estimators	56
5.3 Finite Dimensional Estimators for Bilinear Systems	68
5.4 General Linear-Analytic Systems-- Suboptimal Estimators	76
CHAPTER 6 THE USE OF HARMONIC ANALYSIS IN SUBOPTIMAL FILTER DESIGN	80
6.1 Introduction	80
6.2 A Phase Tracking Problem on $S^1$	81
6.3 The General Problem	87
6.4 Estimation on $S^n$	96
6.5 Estimation on $SO(n)$	101
CHAPTER 7 CONCLUSION AND SUGGESTIONS FOR FUTURE RESEARCH	106
APPENDIX A A SUMMARY OF RELEVANT RESULTS FROM ALGEBRA AND DIFFERENTIAL GEOMETRY	109
A.1 Introduction	109
A.2 Lie Groups and Lie Algebras	109
A.3 Solvable, Nilpotent, and Abelian Groups and Algebras	111
A.4 Simple and Semisimple Groups and Algebras	113
APPENDIX B HARMONIC ANALYSIS ON COMPACT LIE GROUPS	116
B.1 Haar Measure and Group Representations	116
B.2 Schur's Orthogonality Relations	118
B.3 The Peter-Weyl Theorem	121

	PAGE
B.4 The Laplacian	122
B.5 Harmonic Analysis on $SO(n)$ and $S^n$	124
APPENDIX C THE FUBINI THEOREM FOR CONDITIONAL EXPECTATION	132
APPENDIX D PROOFS OF THEOREMS 5.1 AND 5.2	136
D.1 Preliminary Results	136
D.2 Proofs of Theorems 5.1 and 5.2	141
BIBLIOGRAPHY	147
BIOGRAPHICAL NOTE	158

LIST OF FIGURES

	PAGE
Figure 5.1: Block Diagram of the System of Example 5.1	63
Figure 5.2: Block Diagram of the Optimal Filter for Example 5.1	66
Figure 5.3: Block Diagram of the Steady-State Optimal Filter for Example 5.1	69
Figure 6.1: Illustrating the Geometric Interpretation of the Criterion $E[1-\cos(\theta-\hat{\theta})]$	84
Figure 6.2: Illustrating the Form of the Infinite Dimensional Optimal Filter (6.18)-(6.19)	86
Figure 6.3: Illustrating the Form of the Infinite Dimensional Optimal Filter (6.41)-(6.42)	93



## CHAPTER 1

### INTRODUCTION

#### 1.1 Background and Motivation

The problems of stability analysis and state estimation (or filtering) for nonlinear stochastic systems have been the subject of a great deal of research over the past several years. Optimal estimators have been derived for very general classes of nonlinear systems [F1], [K2]. However, the optimal estimator requires, in general, an infinite dimensional computation to generate the conditional mean of the system state given the past observations. This computation involves either the solution of a stochastic partial differential equation for the conditional density or an infinite dimensional system of coupled ordinary stochastic differential equations for the conditional moments. Thus, approximations must be made for practical implementation.

The class of linear stochastic systems with linear observations and white Gaussian plant and observation noises has a particularly appealing structure, because the optimal state estimator consists of a finite dimensional linear system (the Kalman-Bucy filter [K1]), which is easily implemented in real time with the aid of a digital computer. Many types of finite dimensional suboptimal estimators for general nonlinear systems have been proposed [W16], [J1], [L1], [N1], [S3], [S7]. These are primarily based upon linearization and vector space approximations, and their performance can be quite sensitive to the particular system under consideration. An alternative, but relatively untested, type of suboptimal estimator is based on the use of cumulants [W12], [N1].

The above considerations lead us to ask two basic questions in the search for implementable finite dimensional estimators for nonlinear stochastic systems:

- 1) If our objective is to design a suboptimal estimator for a particular class of nonlinear systems, is it possible to utilize the inherent structure of that class of systems in order to design a high-performance estimator?
- 2) Do there exist subclasses of nonlinear systems whose inherent structure leads to finite dimensional optimal estimators (just as the structure of linear systems does in that case)?

Affirmative answers to these questions can lead not only to computationally feasible estimators, but also to valuable theoretical insight into the underlying structure of estimation for general nonlinear systems.

There is, in fact, a class of nonlinear systems which possesses a great deal of structure--the class of bilinear systems. Several researchers (see Chapter 2) have developed analytical techniques for such systems that are as detailed and powerful as those for linear systems. Moreover, the mathematical tools which are useful in bilinear system analysis include not only the vector space techniques that are so valuable in linear system theory, but also many techniques from the theories of Lie groups and differential geometry. In addition, the recent work of Brockett, Krener, Hirschorn, Sedwick, and Lo (see Chapter 2) has extended many of these analytical techniques to more general nonlinear systems. Thus, as emphasized previously by Brockett [B1], [B3] and Willsky [W2], it is often advantageous to view the dynamical system of

interest in the most natural setting induced by its structure, rather than to force it into the vector space framework.

In this thesis we will adopt a similar point of view with regard to stochastic nonlinear systems. We are motivated by the recent work of Willsky [W2]-[W6] and Lo [L2]-[L5], who have successfully applied similar techniques to some stochastic systems evolving on Lie groups. We will investigate the answers to the two basic questions of optimal and sub-optimal estimation posed above through the study of stochastic bilinear systems and stochastic systems described by certain types of Volterra series expansions. Our basic tools are the concepts from the theories of Lie groups and Lie algebras and the Volterra series approach of Brockett [B25] and Isidori and Ruberti [I1], which are so important in the deterministic case. In addition, we rely heavily on many results from the theories of random processes and stochastic differential equations.

In addition to state estimation, stability of stochastic bilinear systems is a problem which has been studied by many researchers in recent years (see Chapter 3). Using many of the same Lie-theoretic concepts, we will also study the stability of bilinear systems driven by colored noise.

## 1.2 Problem Descriptions

This research is concerned with the problems of estimation and stochastic stability. We first discuss a general nonlinear estimation (or filtering) problem [F1], [J1], [K2]. We are given a model in which the state evolves according to the vector Ito stochastic differential equation

$$dx(t) = f(x(t),t)dt + G(x(t),t)dw(t) \quad (1.1)$$

and the observed process is the solution of the vector Ito equation

$$dz(t) = h(x(t),t)dt + R^{1/2}(t)dv(t) \quad (1.2)$$

Here  $x(t)$  is an  $n$ -vector,  $z(t)$  is a  $p$ -vector,  $R^{1/2}$  is the unique positive definite square root of the positive definite matrix  $R$  [B13], and  $v$  and  $w$  are independent Brownian motion (Wiener) processes such that

$$E[w(t)w'(s)] = \int_0^{\min(t,s)} Q(\tau)d\tau \quad (1.3)$$

$$E[v(t)v'(s)] = \min(t,s) \cdot I \quad (1.4)$$

We will refer to  $w$  as a Wiener process with strength  $Q(t)$ .

The filtering problem is to compute an estimate of the state  $x(t)$  given the observations  $z^t \triangleq \{z(s), 0 \leq s \leq t\}$ . The optimal estimate with respect to a wide variety of criteria [J1], including the minimum-variance (least-squares) criterion

$$J = E[(x(t) - \tilde{x}(t))(x(t) - \tilde{x}(t))' | z^t] \quad (1.5)$$

is the conditional mean

$$\hat{x}(t|t) \triangleq E^t[x(t)] \triangleq E[x(t)|z^t] \quad (1.6)$$

Henceforth we will freely interchange the three notations of (1.6) for the conditional expectation given the  $\sigma$ -field  $\sigma\{z(s), 0 \leq s \leq t\}$  generated by the observation process up to time  $t$ . As we will see in Chapter 4, it is also useful in certain cases to use a "normalized version" of the conditional mean.

It is well-known [F1], [J1], [K2] that the conditional mean satisfies the Ito equation

$$d\hat{x}(t|t) = E^t[f(x(t),t)]dt + \{E^t[x(t)h'(x(t),t)] - \hat{x}(t|t) E^t[h'(x(t),t)]\}R^{-1}(t)d\nu(t) \quad (1.7)$$

where the innovations process  $\nu$  is defined by

$$d\nu(t) = dz(t) - E^t[h(x(t),t)]dt \quad (1.8)$$

However, equation (1.7) cannot be implemented in practice, since it is not a recursive equation for  $\hat{x}(t|t)$ . In fact, the right-hand side of (1.7) involves conditional expectations that require in general the entire conditional density of  $x(t)$  for their evaluation. Thus the differential equation for the conditional mean  $\hat{x}(t|t)$  depends in general on all the other moments of the conditional distribution, so in order to compute  $\hat{x}(t|t)$  we would have to solve the infinite set of equations satisfied by the conditional moments of  $x(t)$ .

If  $f$ ,  $G$ , and  $h$  are linear functions of  $x(t)$  and  $x(0)$  is a Gaussian random variable independent of  $v$  and  $w$ , then  $\hat{x}(t|t)$  can be computed with the finite dimensional Kalman-Bucy filter [K1], consisting of (1.7) (which is linear in this case) and a Riccati equation for the conditional covariance  $P(t)$  (which is nonrandom and can be pre-computed off-line). Recently, Lo and Willsky [L2] have shown that the filter which computes  $\hat{x}(t|t)$  is finite dimensional in the case that (1.1) consists of a bilinear system on an abelian Lie group driven by a colored noise process  $\xi$ , and

(1.2) is a linear observation of  $\xi(t)$  (see Chapter 2); also, Willsky [W4] extended this result to a slightly larger class of systems. In this thesis, we will extend these results to a much larger class of systems, described by bilinear equations evolving on solvable and nilpotent Lie groups or by certain types of Volterra series expansions.

In the case that the optimal estimator for  $\hat{x}(t|t)$  is inherently infinite dimensional, one must design suboptimal estimators for practical implementation on a digital computer. As mentioned in Section 1.1, many researchers have developed suboptimal estimators based upon linearization and vector space methods. However, motivated by the successful application of Fourier analysis in the design of nonlinear filters (see Willsky [W6] and Bucy, et al. [B9]), the work of Ito [I3], Grenander [G4], McKean [M7], [M8], Yosida [Y1]-[Y3], and others on random processes on Lie groups, and the successful application of Lie-theoretic ideas to deterministic systems, we are led to investigate the use of harmonic analysis on Lie groups in nonlinear estimator design. The basic idea is to exploit the Lie group structure of certain classes of systems in order to design high-performance suboptimal estimators for these systems.

As with estimation, the problem of the stability of stochastic systems has received much attention, and general methods (including Lyapunov methods) have been developed. Our approach to stochastic stability will be similar to our approach to estimation: we will investigate classes of systems (bilinear systems) for which we can use Lie-theoretic concepts in order to derive stability criteria.

### 1.3 Synopsis

We now present a brief summary of the thesis. In Chapter 2 we review some of the important results for deterministic bilinear systems, and we discuss stochastic bilinear systems in more detail. Chapter 3 is concerned with stochastic stability of bilinear systems, primarily those driven by colored noise. Exact stability criteria are presented for bilinear systems evolving on solvable Lie groups, and approximate techniques for other cases are discussed. In Chapter 4 we present some stochastic bilinear models which relate to the problem of the estimation of rotational processes in three dimensions; these models serve as one motivation for the estimation techniques discussed in Chapters 5 and 6. In Chapter 5 we consider classes of systems for which the optimal conditional mean estimator consists of a finite dimensional nonlinear system of stochastic differential equations (the major results are proved in Appendix D). We also discuss a class of suboptimal estimators which are motivated by these results. In Chapter 6 we investigate the use of harmonic analysis techniques in the design of suboptimal filters for bilinear systems evolving on compact Lie groups and homogeneous spaces.

In Chapter 7 we summarize the results contained in this thesis and suggest some possible research directions which are motivated by this research. In addition, four appendices are included to supplement the discussions presented in the thesis. Appendix A contains a summary of the relevant results from algebra and differential geometry. In Appendix B we review the theory of harmonic analysis on compact Lie groups, which is used primarily in Chapter 6. Appendix C contains a proof of a version of Fubini's theorem which is used in Chapter 5 and Appendix D. Finally, Appendix D contains the proofs of the major results in Chapter 5.

## CHAPTER 2

### BILINEAR SYSTEMS

#### 2.1 Deterministic Bilinear Systems

The basic deterministic bilinear equation studied in the literature [B1]-[B5],[D1],[H1],[I1],[J3],[M5],[M6],[S6], is

$$\dot{x}(t) = \left[ A_0 + \sum_{i=1}^N u_i(t) A_i \right] x(t) \quad (2.1)$$

where the  $A_i$  are given  $n \times n$  matrices, the  $u_i$  are scalar inputs, and  $x$  is either an  $n$ -vector or an  $n \times n$  matrix. As discussed in [B1], the additive control model

$$\dot{x}(t) = \left[ B_0 + \sum_{i=1}^N u_i(t) B_i \right] x(t) + Cu(t) \quad (2.2)$$

(here  $u$  is the vector of the  $u_i$ ) can be reduced to the form (2.1) by state augmentation. As the many examples in the above references illustrate, bilinear system models occur quite naturally in the consideration of a variety of physical phenomena.

The analysis of bilinear systems requires some concepts from the theory of Lie groups and Lie algebras. The relevant results are summarized in Appendix A.

Associated with the bilinear system (2.1) are three Lie algebras:

$$\begin{aligned} \mathcal{L} &= \{A_0, \dots, A_N\}_{LA} \\ \mathcal{B} &= \{A_1, \dots, A_N\}_{LA} \\ \mathcal{L}_0 &= \{ad_{A_0}^i \mathcal{B}, \quad i=0,1,\dots\}_{LA} \end{aligned} \quad (2.3)$$

Notice that  $\mathcal{B} \subset \mathcal{L}_0 \subset \mathcal{L}$ ; in fact,  $\mathcal{L}_0$  is the ideal in  $\mathcal{L}$  generated by  $\{A_1, \dots, A_N\}$ . We also define the corresponding connected Lie groups



$$G = \{\exp \mathcal{L}\}_G \quad G_o = \{\exp \mathcal{L}_o\}_G \quad B = \{\exp \mathcal{B}\}_G \quad (2.4)$$

Then  $B \subset G_o \subset G$ , and  $G_o$  is a normal subgroup of  $G$  [J3],[S1].

The relevance of these Lie groups and Lie algebras to the analysis of (2.1) is illuminated by first considering the case in which  $x$  is an  $n \times n$  matrix. It can easily be shown [J3] that if  $x(t_o) \in G$ , then  $x(t) \in G$  for all  $t \leq t_o$ . In other words, the bilinear system evolves on the Lie group  $G$ . If  $x$  is an  $n$ -vector, then the solution to (2.1) is given by

$$x(t) = X(t)x(0) \quad (2.5)$$

where the transition matrix  $X(t)$  satisfies

$$\dot{X}(t) = \left[ A_o + \sum_{i=1}^N u_i(t) A_i \right] X(t); \quad X(0) = I \quad (2.6)$$

i.e.,  $X(t)$  evolves on  $G$ . Thus the evolution of  $x(t)$  is governed by the action [W11] of the Lie group  $G$  on  $x(0)$ , as defined in (2.5)-(2.6). In addition, the Lie algebras defined above are intimately related to the controllability of (2.1), as described in [B1],[H1],[J3].

One important aspect of the research done so far by other researchers deals with the relationship between bilinear systems and more general nonlinear systems. Consider the nonlinear system

$$\dot{x}(t) = a_o(x(t)) + \sum_{i=1}^N a_i(x(t)) u_i(t); \quad x(0) = x_o \quad (2.7)$$

$$y(t) = c(x(t)) \quad (2.8)$$

where  $c$  and  $a_i$ ,  $i=0,1,\dots,N$  are analytic functions of  $x$  in some neighborhood of the free response. Such systems are called linear-analytic.

Brockett [B25] shows that, under very general conditions, the output of a linear-analytic system has a Volterra series expansion (this will be

discussed in more detail in Chapter 5). Isidori and Ruberti [I1] have derived conditions on the Volterra kernels under which the Volterra series is realizable with a finite dimensional bilinear system.

Krener [K6]-[K9], Hirschorn [H1],[H2], and Sedwick [S11], [S12] have developed an alternative approach, which we will refer to as the "bilinearization" of nonlinear systems. We require some preliminary definitions [W11] in order to describe this approach.

Definition 2.1: Let  $M$  be a differentiable manifold,  $M_x$  the tangent space to  $M$  at  $x \in M$ , and  $T(M) = \bigcup_{x \in M} M_x$  the tangent bundle of  $M$ . A smooth (analytic) vector field on an open set  $U$  in  $M$  is a  $C^\infty$  (analytic) map  $f: U \rightarrow T(M)$  such that  $\pi \circ f = \text{identity map on } U$ , where  $\pi$  is the projection from  $T(M)$  onto  $M$ . A smooth curve  $\phi_{x_0}(t)$  in  $M$  is the integral curve of  $f$  through  $x_0$  if it is the solution of the differential equation  $\dot{x}(t) = f(x(t))$ ,  $x(0) = x_0$ . If for every  $x_0 \in M$ ,  $\phi_{x_0}(t)$  exists for all  $t \in \mathbb{R}$ , then  $f$  is complete. In this case, if we define  $f_t(x_0) \triangleq \phi_{x_0}(t)$ , the collection  $\{f_t, t \in \mathbb{R}\}$  of maps from  $M$  to  $M$  is called the 1-parameter group of  $f$ . Each  $\phi_t$  is an element of  $\text{diff}(M)$ , the group of diffeomorphisms from  $M$  to  $M$ .

Consider the nonlinear system (2.7) where  $x \in M$  and  $a_0, \dots, a_N$  are analytic vector fields. We define the Lie bracket of two vector fields to be the vector field

$$[a_i, a_j](x) = a_i(x) a_j - a_j(x) a_i$$

If  $M = \mathbb{R}^n$  we identify  $M_x$  with  $\mathbb{R}^n$  for all  $x \in \mathbb{R}^n$  and

$$[a_i, a_j](x) = \frac{\partial a_i}{\partial x} (x) a_j(x) - \frac{\partial a_j}{\partial x} (x) a_i(x)$$

where  $(\partial a_j / \partial x)(x)$  is the Jacobian matrix of the map  $a_j: \mathbb{R}^n \rightarrow \mathbb{R}^n$ . The Lie algebra generated by  $a_0, \dots, a_N$  under this Lie bracket is denoted by

$$\mathcal{L} = \{a_0, a_1, \dots, a_N\}_{LA}$$

Krener [K7] shows that if  $\mathcal{L}$  is finite dimensional and certain other technical conditions are satisfied, then there exists an equivalent bilinear system which preserves the solutions of (2.7) locally (i.e., for small  $t$ ). He also shows that, even if  $\mathcal{L}$  is infinite dimensional, then (2.7) can be approximated by a bilinear system, with the error between the solutions growing proportionately to an arbitrary power of  $t$ .

Hirschorn [H1], [H2], employing an important result of Palais [P3], proves a global bilinearization result. Given the system (2.7), where  $x \in M$  and  $a_0, \dots, a_N$  are analytic vector fields, we define

$$D = \{a_0 + \sum_{i=1}^N \alpha_i a_i, \alpha_i \in \mathbb{R}\} \text{ and consider the subset of } \text{diff}(M)$$

$$G(D) = \{f_{t_1}^1 \circ f_{t_2}^2 \circ \dots \circ f_{t_k}^k; f^i \in D, t_i \in \mathbb{R}, k=1,2,\dots\} \quad (2.9)$$

where  $f_t^i$  is the 1-parameter group of  $f^i$ . Notice that  $\mathcal{L} = \{D\}_{LA} = \{a_0, \dots, a_N\}_{LA}$ . Palais shows that if  $\mathcal{L}$  is finite dimensional, then  $G(D)$  can be given the structure of a connected Lie group  $G$  with Lie algebra  $\mathcal{L}(G)$  isomorphic to  $\mathcal{L}$ . If, in addition,  $G$  is isomorphic to a matrix Lie group, then there exists a bilinear system of the form (2.6) such that the solution  $x(t)$  of (2.7) is given by

$$x(t) = X(t)(x(0)) \quad (2.10)$$

where  $X(t) \in G$ .

The action of  $X(t)$  on  $x(0)$  in (2.10) need not be via matrix-vector multiplication; in general, this action can be highly nonlinear. However, if  $M$  and  $G$  are compact, another result of Palais [P5] shows that there exists a finite dimensional orthogonal representation  $D$  of  $G$  (see Appendix B) on the space  $R^m$  (for some  $m$ ) and an imbedding  $\psi: M \rightarrow R^m$  (see [W11], p. 22) such that

$$\psi(X(t)(x(0))) = D(X(t))\psi(x(0)) \quad (2.11)$$

where the action on the right-hand side of (2.11) is given by matrix-vector multiplication. In this case, (2.7) can be solved by solving the bilinear system (2.6) for the orthogonal matrix  $D(X(t))$ , performing the multiplication in (2.11), and recovering  $X(t)x(0)$  via the 1-1 mapping  $\psi$ . The basic idea here is to "lift" the problem onto a Lie transformation group acting on  $M$  which evolves according to a bilinear system (see [H1], [P3], [P4]; this is also related to the recent work of Krener [K11]). These techniques reveal the generality of deterministic bilinear models.

## 2.2 Stochastic Bilinear Systems

Stochastic bilinear systems are described by equations such as (2.1), in which the  $u_i$  are stochastic processes. Such systems have been considered by many authors [B3]-[B7], [C5], [E2], [E3], [I3], [J2], [K3]-[K5], [L2-L5], [M8], [M14], [S4], [S5], [W1]-[W7]. In considering stochastic versions of (2.1), one must be careful to use the appropriate stochastic calculus. For instance, if  $u(t)$  is a vector zero-mean white noise with

$$E[u(t)u'(s)] = Q(t) \delta(t-s)$$

then the Ito stochastic differential analogue of (2.1) is

$$dx(t) = \left\{ [A_0 + \frac{1}{2} \sum_{i,j=1}^N Q_{ij}(t) A_i A_j] dt + \sum_{i=1}^N A_i dw_i(t) \right\} x(t) \quad (2.12)$$

where  $Q_{ij}$  is the  $(i,j)$ th element of  $R$  and  $w$  is the integral of  $u$ ; i.e.,  $w$  is a Brownian motion (Wiener) process with strength  $Q(t)$  such that

$$E[w(t)w'(s)] = \int_0^{\min(t,s)} Q(\tau) d\tau \quad (2.13)$$

Equation (2.12) can be derived in two ways: first, if  $x$  is an  $n \times n$  matrix, (2.12) can be viewed as a generalization of McKean's injection of a Brownian motion into a matrix Lie group [M7],[W1],[L4]. Equation (2.12) can also be obtained from (2.1) by adding the appropriate Wong-Zakai correction term [W9],[W10], which in this case is

$$\left[ \frac{1}{2} \sum_{i,j=1}^N Q_{ij}(t) A_i A_j \right] x(t) dt \quad (2.14)$$

The addition of this correction term, which transforms the Stratonovich equation into the corresponding Ito equation, ensures that (in the case that  $x$  is an  $n \times n$  matrix)  $x(t)$  will evolve on  $G = \{\exp \mathcal{L}\}_G$  in the mean-square sense and almost surely [L4],[L8],[M7].

Associated with the Ito equation (2.12) is a sequence of equations for the moments of the state  $x(t)$ , first derived by Brockett [B3],[B4]. We will assume first that  $x$  is an  $n$ -vector satisfying (2.12). Recall that the number of linearly independent homogeneous polynomials of degree  $p$  in  $n$  variables (i.e.,  $f(cx_1, \dots, cx_n) = c^p f(x_1, \dots, x_n)$ ) is given by

$$N(n,p) = \binom{n+p-1}{p} = \frac{(n+p-1)!}{(n-1)!p!} \quad (2.15)$$

We choose a basis for this  $N(n,p)$  - dimensional space of homogeneous polynomials in  $(x_1, \dots, x_n)$  consisting of the elements

$$\sqrt{\binom{p}{p_1} \binom{p-p_1}{p_2} \dots \binom{p-p_1-\dots-p_{n-1}}{p_n}} x_1^{p_1} x_2^{p_2} \dots x_n^{p_n}; \sum_{i=1}^n p_i = p; p_i \geq 0 \quad (2.16)$$

If we denote the vector consisting of these elements (ordered lexicographically) by  $x^{[p]}$ , then  $x^{[p]}$  is a symmetric tensor of degree  $p$  [H5], and

$$||x||^p = ||x^{[p]}|| \quad (2.17)$$

where  $||x|| = \sqrt{x^T x}$ . It is clear that if  $x$  satisfies the linear differential equation

$$\dot{x}(t) = Ax(t) \quad (2.18)$$

then  $x^{[p]}$  satisfies a linear differential equation

$$\dot{x}^{[p]}(t) = A_{[p]} x^{[p]}(t) \quad (2.19)$$

The matrix  $A_{[p]}$  can be easily computed from  $A$  (see Blankenship [B26]), and in fact is a linear function of  $A$  (so that  $(\alpha A + B)_{[p]} = \alpha A_{[p]} + B_{[p]}$ ). For an interpretation of  $A_{[p]}$  as an infinitesimal linear operator on symmetric tensors of degree  $p$ , see [B3],[G6];  $A_{[p]}$  is also related to the concept of Kronecker sum matrices [B13]. We note only that the eigenvalues of  $A_{[p]}$  are all possible sums of  $p$  (not necessarily distinct) eigenvalues of  $A$ .

Brockett has shown that if  $x$  satisfies (2.12), then  $x^{[p]}$  satisfies the Ito equation

$$dx^{[p]}(t) = \{A_{o[p]} + \frac{1}{2} \sum_{i,j=1}^N Q_{ij} A_{i[p]} A_{j[p]}\} x^{[p]}(t) dt + \sum_{i=1}^N A_{i[p]} x^{[p]}(t) dw_i(t) \quad (2.20)$$

Taking expected values, we get the linear  $p^{\text{th}}$  moment equation

$$\frac{d}{dt} E[x^{[p]}(t)] = \{A_{o[p]} + \frac{1}{2} \sum_{i,j=1}^N A_{i[p]} A_{j[p]}\} E[x^{[p]}(t)] \quad (2.21)$$

Moment equations can also be derived for the case of an  $n \times n$  matrix  $X$  satisfying (2.12). We denote by  $A^{[p]}$  the matrix which verifies

$$y = Ax \implies y^{[p]} = A^{[p]} x^{[p]} \quad (2.22)$$

Some properties of the matrix  $A^{[p]}$  are given in [B3].  $A^{[p]}$  can be interpreted as a linear operator on symmetric tensors of degree  $p$  [B3], [G6], and is known as the symmetrized Kronecker  $p^{\text{th}}$  power of  $A$  [M16]. In fact,  $A_{[p]}$  is the infinitesimal version of  $A^{[p]}$ .

If  $X$  satisfies (2.12), it is easy to show that  $X^{[p]}$  also satisfies (2.20) and (2.21). The analysis of the moment equations for  $x$  and  $X$  is useful in studies of both estimation and stochastic stability for the bilinear equation (2.12), because the infinite sequence of moments contains precisely the same information as the probability distribution of  $x$  or  $X$  (if the moments are bounded and the series of moments converges absolutely [P4, p. 157]).

Another case of considerable importance arises if  $u$  in (2.1) is a colored noise generated by a finite dimensional linear stochastic differential equation

$$d \xi(t) = F(t) \xi(t) dt + G(t) dw(t) + \alpha(t) dt \quad (2.23)$$

$$u(t) = H(t) \xi(t) \quad (2.24)$$

where  $\alpha$ ,  $F$ ,  $G$ , and  $H$  are known and  $w$  is a standard Wiener process (i.e., a Wiener process with strength  $I$ ). In this case, there is no correction term added to (2.1), because  $u$  is "smoother" than white noise. As in the deterministic case,  $x$  evolves on the Lie group  $G$ . Notice that  $x$  by itself is not a Markov process, but the augmented process  $y = (x, \xi)$  is. The equation for  $y$  is then described by (2.1), (2.23), (2.24); it obviously involves products of the state variables  $x$  and  $\xi$ . Thus it does not satisfy the Lipschitz and growth conditions usually assumed in proving the existence and uniqueness of solutions to Ito stochastic differential equations [J1],[W8]. However, Martin [M1] has proved the existence and uniqueness (in the mean-square sense) of solutions to (2.1) driven by a scalar colored noise; the extension to the vector case is straightforward.

In Chapters 4-6, we will consider the estimation of processes described by stochastic bilinear equations of the types just discussed. We now briefly describe the types of measurement processes that will be considered.

One very important measurement process consists of linear measurements corrupted by additive noise

$$dz(t) = L(x(t), \xi(t)) dt + dv(t) \quad (2.25)$$

where  $L$  is a linear operator (recall  $x$  is either an  $n$ -vector or an  $n \times n$  matrix and  $\xi$  is a vector) and  $v$  is a Wiener process. The important implications of linear measurements for bilinear systems will be discussed at length in Chapters 5 and 6. In addition, the bilinear system-linear observation model of (2.12), (2.25) is general enough to include a model with the bilinear system (2.12) and observations



$$dy(t) = \sum_{p=1}^q L_p(x(t), x(t), \dots, x(t))dt + R^{1/2}(t) dv(t) \quad (2.26)$$

where  $L_p$  is a p-linear map. In this case, we can (following Brockett [B2] in the deterministic case) define the augmented state vector

$$\tilde{x} = (x', x^{[2]'}, \dots, x^{[q]'})', \quad (2.27)$$

which will again satisfy a bilinear equation (see (2.20)). However, the observation equation is now linear in the state  $\tilde{x}$ .

A second observation model is the "multiplicative noise case"

$$Z(t) = X(t) V(t) \quad (2.28)$$

in which  $Z$ ,  $X$ , and  $V$  are all  $n \times n$  matrices. Examples of physical systems which can be modeled as bilinear systems with observations described by (2.25) or (2.28) will be discussed in Chapter 4. However, the development of estimation techniques in Chapters 5 and 6 will be limited to the linear observation processes (and their generalizations, as discussed above). In Chapter 5, we will derive finite dimensional estimators for certain classes of bilinear systems driven by colored noise.

As an example of the type of estimation problem we will consider in Chapter 6, suppose the  $n$ -vector  $x$  satisfies the stochastic bilinear equation (2.12) with  $Q(t) = I$ , and the linear observations are of the form

$$dz(t) = H(t)x(t)dt + dv(t) \quad (2.29)$$

where  $v$  is a Wiener process of strength  $R(t)$ . Then the nonlinear filtering equation (1.7) and the moment equation (2.20) yield

$$\begin{aligned}
dE^t[x^{[p]}(t)] &= [A_{o[p]} + \frac{1}{2} \sum_{i,j=1}^N A_{i[p]} A_{j[p]}] E^t[x^{[p]}(t)] dt \\
&\quad + \{E^t[x^{[p]}(t)x'(t)] - E^t[x^{[p]}(t)]E^t[x'(t)]\} H'(t) R^{-1}(t) dv(t)
\end{aligned}
\tag{2.30}$$

where the innovations process is given by

$$dv(t) = dz(t) - H(t)E^t[x(t)]dt \tag{2.31}$$

The filter which computes  $\hat{x}(t|t)$  is obviously infinite-dimensional in general, since the equation for  $E^t[x^{[p]}(t)]$  is coupled to the equation for  $E^t[x^{[p+1]}(t)]$ . The design of suboptimal filters for the case in which  $x$  evolves on a compact Lie group or homogeneous space will be discussed in Chapter 6.

## CHAPTER 3

### STABILITY OF STOCHASTIC BILINEAR SYSTEMS

#### 3.1 Introduction

The stability of stochastic bilinear systems has been investigated recently by Brockett [B3], [B4], Willems [W21]-[W23], Blankenship [B6], [B7], [B26], and Martin [M1] (Martin's thesis also contains a good summary of previous work on this subject). Many definitions of stochastic stability are used by these authors, but we will consider only the following definition for bilinear systems with white noise (equation (2.12)) or colored noise (equation (2.1)), in which  $x$  is an  $n$ -vector.

Definition 3.1: A vector random process  $x$  is  $p^{\text{th}}$  order stable if  $E[x^{[p]}(t)]$  is bounded for all  $t$ , and  $x$  is  $p^{\text{th}}$  order asymptotically stable if

$$\lim_{t \rightarrow \infty} E[x^{[p]}(t)] = 0 \quad (3.1)$$

The bilinear systems (2.1) and (2.12) are  $p^{\text{th}}$  order (asymptotically) stable if the solution  $x$  is  $p^{\text{th}}$  order (asymptotically) stable for all initial conditions  $x(0)$  independent of the  $u_i$  (in (2.1)) or the  $v_i$  (in (2.12)) and such that  $E[x^{[p]}(0)] < \infty$ .

We first consider the white noise case (2.12). Since the  $p^{\text{th}}$  moment equation (2.21) is linear, the usual stability results for linear systems [B8], [C2] immediately yield the following theorem.

Theorem 3.1: The system (2.12) with  $R(t) = I$  is  $p^{\text{th}}$  order asymptotically stable if and only if the matrix

$$D_p = A_{0[p]} + \frac{1}{2} \sum_{i=1}^N (A_{i[p]})^2 \quad (3.2)$$

has all its eigenvalues in the left half plane ( $\text{Re } \lambda < 0$ ). The system is  $p^{\text{th}}$  order stable if all the eigenvalues of  $D_p$  have negative or zero real parts, and if  $\lambda$  is an eigenvalue with  $\text{Re}(\lambda) = 0$ , then  $\lambda$  is a simple zero of the minimal polynomial of  $D_p$ .

The explicit computation of the eigenvalues of  $D_p$  in terms of  $A_0, A_1, \dots, A_N$  is an unsolved problem in the general case. However, Brockett [B4] has shown that if  $A_0, A_1, \dots, A_N$  are all skew-symmetric and (2.1) is controllable on the sphere  $S^{n-1}$ , then the solution of (2.12) is such that all moments approach the moments associated with the uniform distribution on  $S^{n-1}$  as  $t$  approaches infinity. He has also shown [B3] that in the scalar case ( $n = N = 1$ ) it is not possible for (2.12) to be  $p^{\text{th}}$  order stable for all  $p$  (assuming that  $A_1 \neq 0$ ). Willems [W22] has derived explicit necessary and sufficient conditions in terms of the eigenvalues of  $A_0, A_1, \dots, A_N$  for the  $p^{\text{th}}$  order asymptotic stability of (2.12) in the case that  $\mathcal{L} = \{A_0, A_1, \dots, A_N\}_{LA}$  is solvable (see Section A.3). However, this has not been accomplished in the general case (or, for example, if  $\mathcal{L}$  is semisimple).

In the next section, we present a procedure for obtaining necessary and sufficient conditions for  $p^{\text{th}}$  order (asymptotic) stability of the system (2.1) driven by colored noise, for the special case in which  $\mathcal{L}$  is solvable. In Section 3.3 we discuss some approximate techniques for deriving sufficient conditions for stability in the case that  $\mathcal{L}$  is not solvable.

### 3.2 Bilinear Systems with Colored Noise--The Solvable Case

In this section we analyze the stability of the bilinear system (2.1) driven by a colored noise process  $u$ . Assume that  $x$  is an  $n$ -vector and  $u$  is a Gaussian random process independent of  $x(0)$  with

$$E[u(t)] = m(t) \quad (3.3)$$

$$E[(u(t)-m(t))(u(s)-m(s))'] = P(t,s) \quad (3.4)$$

The purpose of this section is to show that necessary and sufficient conditions for  $p^{\text{th}}$  order (asymptotic) stability can be derived if  $\mathcal{L} = \{A_0, A_1, \dots, A_N\}_{LA}$  is solvable. We first outline one general procedure for determining these conditions, and then present several examples to illustrate the method.

As noted in Chapter 2, we can write the solution to (2.1) in terms of the transition matrix  $X$  via (2.5)-(2.6). If  $\mathcal{L}$  is solvable, we can derive a closed-form expression for  $X$  in terms of  $u$ . The first work on the derivation of closed-form expressions for the solution of (2.1) in the solvable case was done by Wei and Norman [W14], [W15]. Martin [M1] used their results to calculate stochastic stability conditions in the solvable case. Our alternate, but computationally equivalent, approach proceeds as follows.

First we make use of Lemma A.1, which proves the existence of a (possibly complex-valued) nonsingular matrix  $P$  such that  $B_i \triangleq PA_i P^{-1}$  is in upper triangular form for  $i = 0, 1, \dots, N$ . Then the equation

$$\dot{Y}(t) = [B_0 + \sum_{i=1}^N B_i u_i(t)]Y(t); Y(0) = I \quad (3.5)$$

can be solved in closed-form by quadrature. Consequently

$$X(t) = P^{-1}Y(t)P \quad (3.6)$$

and  $X$  involves only exponentials and polynomials in the integrals of the components of  $u$  (see Example 3.3). Since  $u$  is Gaussian and independent of  $x(0)$ , the expectations of the components of  $X$  can be evaluated in closed form (see the examples). Hence

$$E[x(t)] = E[X(t)] E[x(0)] \quad (3.7)$$

can be evaluated in closed form, and we can determine necessary and sufficient conditions for first order stability.

In order to determine conditions for  $p^{\text{th}}$  order stability, we consider the equation for  $x^{[p]}$

$$\frac{d}{dt} x^{[p]}(t) = \left[ A_{0[p]} + \sum_{i=1}^N A_i^{[p]} u_i(t) \right] x^{[p]}(t) \quad (3.8)$$

Let

$$\mathcal{L}_{[p]} = \{ A_{0[p]}, A_{1[p]}, \dots, A_{N[p]} \}_{LA} \quad (3.9)$$

Since [B3]

$$[A, B]_{[p]} = [A_{[p]}, B_{[p]}] \quad (3.10)$$

we see that  $\mathcal{L}_{[p]}$  is solvable if and only if  $\mathcal{L}$  is. Therefore, we can use the preceding analysis to determine first order stability conditions for (3.8) (i.e.,  $p^{\text{th}}$  order stability conditions for the original system (2.1)).

Example 3.1 [M1], [B8, p. 58]: Consider the scalar system

$$\dot{x}(t) = (a + u(t))x(t) \quad (3.11)$$

where  $a$  is constant and  $u$  is a Gaussian random process with

$$E[u(t)] = 0 \quad E[u(t)u(t+\tau)] = \sigma^2 e^{-\alpha|\tau|} \quad (3.12)$$

where  $\alpha > 0$ . The solution to (3.11) is

$$x(t) = e^{at+\eta(t)} x(0) \quad (3.13)$$

$$\eta(t) = \int_0^t u(s) ds \quad (3.14)$$

Recall [M11] that the characteristic function of a Gaussian random vector  $y$  with mean  $m$  and covariance  $P$  is given by

$$M_y(u) = E[e^{iu'y}] = e^{iu'm - \frac{1}{2} u'Pu} \quad (3.15)$$

Since  $\eta$  in (3.14) is Gaussian, we can use (3.15) to compute

$$E[x(t)] = E[x(0)] \exp \left\{ at + \frac{1}{\alpha} \sigma^2 t + \frac{\sigma^2}{2\alpha} (e^{-\alpha t} - 1) \right\} \quad (3.16)$$

Hence (3.11) is first order asymptotically stable if and only if

$$a < -\frac{\sigma^2}{\alpha} \quad (3.17)$$

(notice that this requires  $a < 0$ ). Since

$$\frac{d}{dt} x^p(t) = (pa + pu(t))x^p(t) \quad (3.18)$$

we have that (3.11) is  $p^{\text{th}}$  order asymptotically stable if and only if

$$a < -\frac{p\sigma^2}{\alpha} \quad (3.19)$$

Also,  $a = -p\sigma^2/\alpha$  implies  $p^{\text{th}}$  order stability.

Example 3.2 [W23], [M12]: Consider the  $n$ -dimensional system (2.1), where  $u$  is a Gaussian random process with statistics (3.3)-(3.4), and

assume that  $\mathcal{L}$  is abelian. Then the solution of (2.1) is

$$x(t) = \exp(A_0 t) \left\{ \prod_{i=1}^N \exp \left[ A_i \int_0^t u_i(s) ds \right] x(0) \right\} \quad (3.20)$$

As in the previous example, the statistics of  $x$  are completely determined by those of the integral of the noise process  $u$ , and explicit stability criteria can be derived.

For example consider the system

$$\dot{x}(t) = Ax(t) + u(t)x(t) \quad (3.21)$$

where  $A$  is a given  $n \times n$  matrix and  $u$  is the same as in the preceding example. It can be shown [M12], [W23] that (3.21) is  $p^{\text{th}}$  order asymptotically stable if and only if

$$\text{Re}(\lambda_i) < -p\sigma^2/\alpha$$

for all eigenvalues  $\lambda_i$  of  $A$ . For a more complete discussion of the abelian case, see Willems [W23].

Example 3.3: Consider the system

$$\dot{x}(t) = \left[ \sum_{i=1}^3 A_i u_i(t) \right] x(t) \quad (3.22)$$

where

$$A_1 = \begin{bmatrix} 0 & 0 \\ -1 & 1 \end{bmatrix} \quad A_2 = \begin{bmatrix} 1 & -1 \\ 1 & -1 \end{bmatrix} \quad A_3 = \begin{bmatrix} 1 & 0 \\ 1 & 0 \end{bmatrix}$$

and  $u$  is a stationary Gaussian random process with statistics

$$E[u(t)] = m \triangleq [m_1, m_2, m_3]' \quad (3.23)$$



$$E[(u(t)-m)(u(s)-m)'] = P(t,s) = P(t-s) \quad (3.24)$$

It is easy to verify that  $\mathcal{L}$  is solvable and

$$P = \begin{bmatrix} 1 & 0 \\ 1 & -1 \end{bmatrix} \quad (3.25)$$

triangularizes  $\mathcal{L}$ . Thus if  $y = Px$ , then

$$\dot{y}(t) = \begin{bmatrix} u_3(t) & u_2(t) \\ 0 & u_1(t) \end{bmatrix} y(t) \quad (3.26)$$

and

$$y(t) = \begin{bmatrix} \exp \left[ \int_0^t u_3(s) ds \right] & \int_0^t \exp \left[ \int_\tau^t u_3(s) ds + \int_0^\tau u_1(s) ds \right] u_2(\tau) d\tau \\ 0 & \exp \left[ \int_0^t u_1(s) ds \right] \end{bmatrix} y(0) \quad (3.27)$$

$\triangleq Y(t)y(0)$

The expectations of the quantities in (3.27) can be evaluated by means of the characteristic function (3.15). Some simple calculations yield

$$E[Y_{11}(t)] = \exp \left[ m_3 t + \frac{1}{2} \int_0^t \int_0^t P_{33}(\sigma_1 - \sigma_2) d\sigma_2 d\sigma_1 \right] \quad (3.28)$$

$$E[Y_{22}(t)] = \exp \left[ m_1 t + \frac{1}{2} \int_0^t \int_0^t P_{11}(\sigma_1 - \sigma_2) d\sigma_2 d\sigma_1 \right] \quad (3.29)$$

$$E[Y_{12}(t)] = \int_0^t (m_2 + \beta(s)) \exp \left[ m_3(t-\tau) + m_1\tau + \frac{1}{2} \gamma(s) \right] ds \quad (3.30)$$

$$\beta(s) = \int_s^t P_{23}(s-\sigma) d\sigma + \int_0^s P_{21}(s-\sigma) d\sigma \quad (3.31)$$

$$\begin{aligned} \gamma(s) = & 2 \int_s^t \int_0^s P_{31}(\sigma_1 - \sigma_2) d\sigma_2 d\sigma_1 + \int_s^t \int_s^t P_{33}(\sigma_1 - \sigma_2) d\sigma_2 d\sigma_1 \\ & + \int_0^s \int_0^s P_{11}(\sigma_1 - \sigma_2) d\sigma_2 d\sigma_1 \end{aligned} \quad (3.32)$$

Then conditions for asymptotic stability can be determined from the closed-form expression

$$E[x(t)] = P^{-1} E[Y(t)] P E[x(0)] \quad (3.33)$$

For example, suppose that  $u_1$ ,  $u_2$ , and  $u_3$  are independent with  $E[u_i(t)] = m$ ,  $i = 1, 2, 3$ , and

$$E[u_i(t)u_i(t+\tau)] = \sigma_i^2 \exp[-\alpha_i |\tau|], \quad \alpha_i > 0 \quad i = 1, 2, 3 \quad (3.34)$$

In this case the system (3.22) is first order asymptotically stable if and only if

$$m < -\max(\sigma_1^2/\alpha_1, \sigma_3^2/\alpha_3) \quad (3.35)$$

Other examples of this technique are discussed in [M12].

### 3.3 Bilinear Systems with Colored Noise--The General Case

If the Lie algebra  $\mathcal{L}$  is not solvable, then (2.1) cannot be solved in closed form, and the approach of the previous section is not applicable.

In this section we discuss some approximate methods for deriving stability conditions.

Blankenship [B26] has used some results from stochastic averaging theory to derive conditions for the stability of the "slowly varying" portion of the moments of (2.1) in the case that the noise  $u(t)$  is bounded and satisfies some other technical conditions. However, the boundedness assumption excludes Gaussian noise processes.

One procedure for deriving sufficient conditions for the  $p^{\text{th}}$  order stability ( $p$  even) of a general bilinear system driven by Gaussian noise is based on a method of Brockett [B27]. Assume that  $x(t)$  satisfies

$$\dot{x}(t) = [A + Bu(t)]x(t) \quad (3.36)$$

where  $u$  is a Gaussian process satisfying (3.12). We use a simple inequality [B8, p. 128] to show that

$$\begin{aligned} \frac{d}{dt}(x'(t)x(t)) &= x'(t)[A+A' + u(t)(B + B')]x(t) \\ &\leq [\lambda_{\max}(A + A') + u(t)\lambda_{\max}(B + B')]x'(t)x(t) \end{aligned} \quad (3.37)$$

where  $\lambda_{\max}(P)$  denotes the maximum eigenvalue of  $P$ . Hence

$$x'(t)x(t) \leq y^2(t) \quad (3.38)$$

where  $y$  is a scalar process satisfying

$$\begin{aligned} \dot{y}(t) &= \frac{1}{2} [\lambda_{\max}(A + A') + u(t)\lambda_{\max}(B + B')]y(t) \\ y(0) &= [x'(0)x(0)]^{1/2} \end{aligned} \quad (3.39)$$

or, equivalent, we have

$$\dot{x}'(t)x(t) \leq \eta(t) \quad (3.40)$$

where  $\eta$  is a scalar process satisfying

$$\begin{aligned} \dot{\eta}(t) &= [\lambda_{\max}(A + A') + u(t)\lambda_{\max}(B + B')] \eta(t) \\ \eta(0) &= x'(0)x(0) \end{aligned} \quad (3.41)$$

The condition of Example 3.1 then states that (3.41) is  $p^{\text{th}}$  order asymptotically stable (which implies that (3.36) is  $(2p)$ -th order asymptotically stable) if

$$\lambda_{\max}(A + A') < -p\sigma^2[\lambda_{\max}(B + B')]^2/\alpha \quad (3.42)$$

The stability condition (3.42) could have been derived from (3.37) by a direct application of the Gronwall-Bellman inequality [B8, p. 19]. However, the present formulation suggests generalizations in a certain direction which will be discussed at the end of this section.

The following examples indicate that this procedure, while providing useful stability criteria in some cases, often provides little or no information about the stability of (3.36). This is to be expected, because we have essentially bounded the process  $x$  in (3.36) by a scalar process, thus neglecting many of the important characteristics of  $x$ .

Example 3.4: Let  $B = I$  and

$$A = \begin{bmatrix} -1 & 2 \\ 0 & -2 \end{bmatrix}$$

Then a simple computation shows that  $\lambda_{\max}(A + A') = -3 + \sqrt{5}$ , and the

criterion (3.42) implies that (3.36) is  $(2p)$ -th order asymptotically stable if

$$\frac{\sigma^2}{\alpha} < \frac{3-\sqrt{5}}{4p} \approx \frac{1}{p} \quad (.191) \quad (3.43)$$

Since  $\mathcal{L}$  is abelian, Example 3.2 gives the necessary and sufficient condition for asymptotic stability:

$$\frac{\sigma^2}{\alpha} < \frac{1}{2p} \quad (3.44)$$

Thus (3.42) provides a sufficient condition which is, however, conservative (i.e., (3.42) provides a smaller region of stability than Example 3.2).

Example 3.5: Let  $A$  be arbitrary and let

$$B = \begin{bmatrix} -1 & 2 \\ 0 & -1 \end{bmatrix}$$

Then  $\lambda_{\max}(B + B') = 0$ , and the condition (3.42) implies  $(2p)$ -th order asymptotic stability of (3.36) if

$$\lambda_{\max}(A + A') < 0 \quad (3.45)$$

Notice that this result is independent of the noise statistics.

Example 3.6: Let  $B = I$  and

$$A = \begin{bmatrix} -1 & 2 \\ 0 & -1 \end{bmatrix}$$

Since  $\lambda_{\max}(A + A') = 0$ , the condition (3.42) yields no information

about asymptotic stability. However, we know from Example 3.2 that a necessary and sufficient condition for  $p^{\text{th}}$  order asymptotic stability of (3.36) is

$$\frac{\sigma^2}{\alpha} < \frac{1}{p} \quad (3.46)$$

Example 3.7: Consider the damped harmonic oscillator, in which

$$A = \begin{bmatrix} 0 & 1 \\ -1 & -2\zeta \end{bmatrix} \quad B = \begin{bmatrix} 0 & 0 \\ 1 & 0 \end{bmatrix}$$

where  $\zeta > 0$ . We again have  $\lambda_{\max}(A + A') = 0$ , so (3.42) provides no information about stochastic stability.

The damped harmonic oscillator of Example 3.7, for which the general criterion (3.42) is not useful, has been considered by Martin [M1] from a different point of view. Martin investigated the second order (mean-square) asymptotic stability of only the first component  $x_1$  (the position). He expanded the solution  $x_1(t)$  in a Volterra series and bounded this series term-by-term with the solution of a scalar equation, thus obtaining sufficient conditions for the mean-square asymptotic stability of  $x_1$ . He then optimized over the parameters of the scalar system in order to obtain the largest region of stability.

Both of these methods basically consist of bounding  $x'(t)x(t)$  (or  $x_1^2(t)$ ), where  $x$  is the solution of (3.36), by  $y^2(t)$  (where  $y$  is the solution of a scalar system). The results of Example 3.1 then provide a sufficient condition for  $(2p)$ -th order asymptotic stability. However, the techniques of Section 3.2 enable us to compute necessary

and sufficient stability conditions for systems more general than scalar systems--namely, systems for which  $\mathcal{L}$  is solvable. It thus seems reasonable to conjecture that better stability conditions (i.e., larger regions of asymptotic stability) can be derived by bounding  $x'(t)x(t)$  (where  $x$  is the solution of (3.36)) by  $y'(t)y(t)$  (where  $y$  is the solution of

$$\dot{y}(t) = (\tilde{A} + \tilde{B}u(t))y(t) \quad (3.47)$$

and  $\tilde{A}$  and  $\tilde{B}$  are upper triangular). We have attempted to generalize to the solvable case both of the above methods of bounding, but our efforts have been unsuccessful to date.

## CHAPTER 4

### MOTIVATION: ESTIMATION OF ROTATIONAL PROCESSES IN THREE DIMENSIONS

#### 4.1 Introduction

Many practical estimation problems can be analyzed in the framework of bilinear systems evolving on Lie groups or homogeneous spaces. For example, several communications problems (such as the phase tracking example of Chapter 6) can be viewed as bilinear systems evolving on the circle  $S^1$  [B9],[G2],[L2],[M9],[W3],[W6],[W7],[W12]. As we shall see in subsequent chapters, the fact that  $S^1$  is an abelian Lie group (i.e., rotations in one dimension commute) provides an important simplification. In this chapter we formulate several problems of practical importance involving rotations in three dimensions (we will rely substantially on the discussion in [W12]). These problems are considerably more difficult than those in one dimension, since rotations in three-space do not commute [M8],[S4],[W2].

In this chapter, we will make several approximations in order to develop models for several physical systems. These approximations are often justifiable. However, we use these models primarily to find useful filter structures for such problems. As we will show in Chapters 5 and 6, these models do lead to novel and useful filters.

The problem of estimating the angular velocity and orientation (or attitude) of a rigid body has been studied by many authors [B4],[B10],[B18],[L6],[L8],[M10],[S4],[S5],[W2],[W13]. In general the optimal estimator (or filter) is infinite dimensional, so practical estimation techniques for these problems are inherently suboptimal.



One structural feature of the rigid body orientation-angular velocity problem which is very important is that the space of possible orientations defines a Lie group [W2],[S4],[S5], and the combined orientation-angular velocity space is the tangent bundle of the orientation space and is thus a homogeneous space [B11]; in fact, it can be given a Lie group structure isomorphic to the Euclidean group in three-space [M4]. There are also Lie-theoretic interpretations of four of the most widely used representations of the attitude of a rigid body -- direction cosines, unit quaternions, Euler angles, and Cayley-Klein parameters. We will exploit this Lie group structure in our consideration of the estimation problem.

We will consider only the direction cosine and quaternion descriptions; the other representations are discussed in [W2] and [S5].

#### 4.2 Attitude Estimation with Direction Cosines

The orientation of a rigid body can be described by the matrix of direction cosines [W17],[E4] between two sets of orthogonal axes -- one rotating with the body (b-frame) and the other an inertial reference frame (i-frame). The direction cosine matrix is a 3x3 orthogonal matrix ( $X'X=I$ ) with  $\det X = +1$ . The set of all such matrices form the matrix Lie group  $SO(3)$ [B1],[S1],[W2] (see also Appendices A and B). Let  $C_{\alpha}^{\beta}$  denote the direction cosine matrix of the  $\beta$ -frame with respect to the  $\alpha$ -frame. If the 3-vector  $\xi(t)$  is the angular velocity of the body with respect to inertial space in body coordinates, the evolution of the orientation of the body is described by the bilinear equation

$$\dot{X}(t) = - \left[ \sum_{i=1}^3 \xi_i(t) R_i \right] X(t) \quad (4.1)$$

where  $X(t) \triangleq C_i^b(t) \in SO(3)$  and the  $R_i$ , given by

$$R_1 = \begin{bmatrix} 0 & 0 & 0 \\ 0 & 0 & -1 \\ 0 & 1 & 0 \end{bmatrix} \quad R_2 = \begin{bmatrix} 0 & 0 & 1 \\ 0 & 0 & 0 \\ -1 & 0 & 0 \end{bmatrix} \quad R_3 = \begin{bmatrix} 0 & -1 & 0 \\ 1 & 0 & 0 \\ 0 & 0 & 0 \end{bmatrix} \quad (4.2)$$

form a basis for  $\mathfrak{so}(3)$ , the matrix Lie algebra associated with  $SO(3)$ . The fact that  $SO(3)$  is a simple Lie group (see Appendix A) complicates the study of dynamics on  $SO(3)$ , because this implies that there is no global closed-form solution to (4.1). Wei and Norman [W14],[W15] have shown the existence of local expressions for the solution to equations of the form (2.1); however, these solutions are global only in certain cases. We will exploit this fact for the case of solvable Lie groups in order to obtain finite dimensional optimal nonlinear estimators in the next section. We also note that the local Wei-Norman representation of the solution of (4.1) corresponds to an Euler angle description, which is well known to exist only locally (see [W17], where this fact is related to the phenomenon of "gimbal-lock").

We assume that the angular velocity in (4.2) is a stochastic process satisfying

$$d\xi(t) = f(t)dt + A(t) \xi(t)dt + G(t) dw(t) \quad (4.3)$$

where  $f$  and  $G$  are known,  $\xi(0)$  is normally distributed, and  $w$  is a

standard Wiener process independent of  $\xi(0)$ . Here  $f$  is a vector of known torques acting on the body, and the Brownian motion term represents random disturbances. The angular velocity equation (4.3) is simpler than the usual nonlinear Euler equations; this approximation is reasonable in some cases (see [W12]).

We will consider three different measurement processes -- one motivated by a strapdown inertial navigation system, one by an inertial system in which a platform is to be kept inertially fixed, and one by a star tracker. In a strapdown system [W17], one receives noisy information about either angular velocity or incremental angle changes. Assuming that the size of the increment is small, either type of information can be modeled (see [W12]) by the Ito equation

$$dz(t) = C(t)\xi(t)dt + S^{1/2}(t)dv(t) \quad (4.4)$$

where  $S=S' > 0$  and  $v$  is a standard Wiener process, independent of  $\xi$ .

A second type of observation process is suggested by an inertial system equipped with a platform that is to "instrument" (i.e., remain fixed with respect to) the inertial reference frame. We must consider the direction cosines relating the body-fixed frame (b-frame), platform frame (p-frame), and inertial reference frame (i-frame). Recall that

$$X(t) = C_i^b(t) \quad (4.5)$$

Also, by noting the relative orientation of the platform and the body (perhaps by reading of gimbal angles [W17]), we can measure

$$M(t) = C_p^b(t) \quad (4.6)$$

Let

$$V(t) = C_p^i(t) \quad (4.7)$$

represent the noise due to platform misalignment. We model the gyro drifts and other inaccuracies which cause platform misalignment by the equations

$$\eta_p(t) = \xi_p(t) + v_p(t) \quad (4.8)$$

$$\eta_b(t) = \xi_b(t) + v_b(t) \quad (4.9)$$

where  $\eta_p$  and  $\eta_b$  denote the angular velocity of the b-frame with respect to the p-frame in p and b coordinates, respectively;  $\xi_p$  and  $\xi_b$  denote the angular velocity of the b-frame with respect to the i-frame in p and b coordinates, respectively; and  $v_p$  and  $v_b$  denote the error in the measurement (the angular velocity of the i-frame with respect to the p-frame) in p and b coordinates, respectively. The error process  $v$  will be modeled as a Brownian motion process with strength  $S(t)$ .

We now derive an equation for the platform misalignment  $V(t)$  (this derivation is due to Willsky [W20]). For ease of notation, the derivation will be performed using Stratonovich calculus ( $\dagger$  will denote the Stratonovich differential). The matrix  $M(t)$  satisfies

$$dM(t) = [\tilde{\xi}_p(t)dt + \dagger \tilde{v}_p(t)]M(t) \quad (4.10)$$

where, for any 3-vector  $\alpha$ ,

$$\tilde{\alpha} = - \sum_{i=1}^3 R_i \alpha_i \quad (4.11)$$

Since [E4, p.119]

$$\tilde{\eta}_b(t) = M(t) \tilde{\eta}_p(t) M'(t) \quad (4.12)$$

we have

$$dM(t) = M(t) [\tilde{\xi}_p(t) dt + \mathbf{d}\tilde{v}_p(t)] \quad (4.13)$$

Since our measurement consists of

$$M(t) = X(t)V(t) \quad (4.14)$$

the platform misalignment satisfies

$$V(t) = X'(t)M(t) \quad (4.15)$$

and

$$\begin{aligned} dV(t) &= \{-X'(t) \tilde{\xi}_p(t) M(t) dt + X'(t) M(t) [\tilde{\xi}_p(t) dt + \mathbf{d}\tilde{v}_p(t)] M'(t) M(t)\} \\ &= \{-X'(t) \tilde{\xi}_p(t) M(t) dt + X'(t) \tilde{\xi}_p(t) M(t) dt + X'(t) M(t) \mathbf{d}\tilde{v}_p(t)\} dt \\ &= V(t) \mathbf{d}\tilde{v}_p(t) \end{aligned} \quad (4.16)$$

or, in Ito form,

$$dV(t) = V(t) \left[ - \sum_{i=1}^3 R_i dv_i(t) + \frac{1}{2} \sum_{i,j=1}^3 S_{ij}(t) R_i R_j dt \right] \quad (4.17)$$

and  $V$  is a left-invariant  $SO(3)$  Brownian motion (see Section 6.3 and [L8],[M8],[W2]).

The third measurement process is motivated by the use of a star tracker [F2],[F3],[I4],[P1],[R1]. In a star tracker, the star chosen as a reference has associated with it a known unit position vector  $\alpha$  in inertial coordinates, pointing from the origin of the inertial frame along the line of sight to the star. The vector  $\alpha$  must be transformed to take into account the position and velocity of the body; thus  $\alpha$  will be time-varying if the body is in motion (for example, if we are estimating the attitude of a satellite in orbit). A second type of time dependence in  $\alpha$  arises because different stars (with different position vectors) can be used for sightings. As in [F2], the measurement consists of noisy observations of the unit position vector of the star in body coordinates (that is, observations of  $C_1^b(t)\alpha(t)$  plus white noise). We model such observations via the Ito equation

$$dz(t) = X(t)\alpha(t)dt + S^{1/2}(t)dv(t) \quad (4.18)$$

where  $S=S' > 0$  and  $v$  is a standard Wiener process.

For all three measurement processes associated with the state equations (4.1) and (4.3), the problem of interest is that of estimating  $X(t)$  and  $\xi(t)$  given the past observations:  $z^t \triangleq \{z(s), 0 \leq s \leq t\}$  if we use (4.4) or (4.18), or  $M^t \triangleq \{M(s), 0 \leq s \leq t\}$  if our observations satisfy (4.14). We will consider an estimation criterion of the constrained least-squares type; i.e., we wish to find the estimate  $(\tilde{X}(t|t), \tilde{\xi}(t|t))$  that minimizes the conditional error covariance

$$J = E[(\xi(t) - \tilde{\xi}(t|t))' (\xi(t) - \tilde{\xi}(t|t)) + \text{tr}\{(X(t) - \tilde{X}(t|t))' (X(t) - \tilde{X}(t|t))\} | y^t] \quad (4.19)$$

subject to the constraint

$$\tilde{X}(t|t)' \tilde{X}(t|t) = I \quad (4.20)$$

Here  $y^t$  denotes either  $z^t$  or  $M^t$ , depending on which observation process we are considering. It is well-known [B16],[B21],[C4] that the optimal estimate for the criterion (4.19)-(4.20) is given by

$$\tilde{\xi}(t|t) = \hat{\xi}(t|t) \triangleq E[\xi(t)|y^t] \quad (4.21)$$

$$\tilde{X}(t|t) = \hat{X}(t|t) [\hat{X}(t|t)' \hat{X}(t|t)]^{-1/2} \quad (4.22)$$

Notice that both of the observation processes (4.4) and (4.18) are linear in the augmented state  $(X(t), \xi(t))$ . The implications of linear measurements for bilinear systems will be explored in Chapters 5 and 6 with regard to estimation problems.

### 4.3 Attitude Estimation with Quaternions

A second way of characterizing the attitude of a rotating rigid body is by a quaternion. The unit quaternions  $Q$  are defined by

$$Q \triangleq \{q = q_1 + q_2 i + q_3 j + q_4 k \mid \sum_{i=1}^4 q_i^2 = 1\} \quad (4.23)$$

where the group multiplication on  $Q$  is defined by the relations

$$\begin{aligned} i^2 = j^2 = k^2 = -1 & & ij = -ji = k \\ jk = -kj = i & & ki = -ik = j \end{aligned} \quad (4.24)$$

We note that there is a Lie group isomorphism [W11] between  $Q$  and the unit 3-sphere

$$S^3 \triangleq \{(x_1, x_2, x_3, x_4) \in \mathbb{R}^4 \mid x_1^2 + x_2^2 + x_3^2 + x_4^2 = 1\} \quad (4.25)$$

where we identify

$$(x_1, x_2, x_3, x_4) \longleftrightarrow x_1 + x_2 i + x_3 j + x_4 k \quad (4.26)$$

A vector  $x \in \mathbb{R}^3$  can be represented as a quaternion with  $q_1 = 0$ :

$$\tilde{x} = x_1 i + x_2 j + x_3 k \quad (4.27)$$

If the quaternion  $q$  represents the orientation of the  $\beta$ -frame with respect to the  $\alpha$ -frame, then the vector  $x$  is transformed from  $\alpha$ -coordinates to  $\beta$ -coordinates by

$$x_\beta = q x_\alpha q^* \quad (4.28)$$

where the conjugate of  $q$  is defined by

$$q^* = q^{-1} = q_1 - q_2 i - q_3 j - q_4 k \quad (4.29)$$

Comparing (4.28) to the equivalent expression in terms of direction cosines

$$x_\beta = C_\alpha^\beta x_\alpha \quad (4.30)$$

we see that there is a Lie group homomorphism  $g : Q \rightarrow SO(3)$  given by

$$g(q_1 + q_2 i + q_3 j + q_4 k) = \begin{bmatrix} q_1^2 + q_2^2 - q_3^2 - q_4^2 & 2(q_2 q_3 - q_1 q_4) & 2(q_2 q_4 + q_1 q_3) \\ 2(q_2 q_3 + q_1 q_4) & q_1^2 - q_2^2 + q_3^2 - q_4^2 & 2(q_3 q_4 - q_1 q_2) \\ 2(q_2 q_4 - q_1 q_3) & 2(q_3 q_4 + q_1 q_2) & q_1^2 - q_2^2 - q_3^2 + q_4^2 \end{bmatrix} \quad (4.31)$$



Notice that

$$g(q) = g(-q) \quad \forall q \in Q \quad (4.32)$$

In fact, one can show that  $Q \approx S^3$  is the simply connected covering group [W11] of  $SO^3$ , and we have the Lie group isomorphism

$$SO(3) \approx Q/\{1\} \quad (4.33)$$

where  $\{1\}$  is the subgroup of  $Q$  containing those two elements.

If  $\xi(t)$  is the angular velocity of a rigid body with respect to inertial space in body coordinates and  $q$  is the quaternion representing the orientation of the body frame with respect to inertial space, then the orientation equation corresponding to (4.1) is

$$\frac{d}{dt} \bar{q}(t) = - \left[ \sum_{i=1}^3 \xi_i(t) \tilde{R}_i(t) \right] \bar{q}(t) \quad (4.34)$$

where the vector corresponding to the quaternion  $q$  is  $\bar{q} = (q_1, q_2, q_3, q_4)'$  and the  $\tilde{R}_i$ , given by

$$\tilde{R}_1 = \begin{bmatrix} 1 & -1 & 0 & 0 \\ 1 & 0 & 0 & 0 \\ 0 & 0 & 0 & -1 \\ 0 & 0 & 1 & 0 \end{bmatrix} \quad \tilde{R}_2 = \begin{bmatrix} 0 & 0 & -1 & 0 \\ 0 & 0 & 0 & 1 \\ 1 & 0 & 0 & 0 \\ 0 & -1 & 0 & 0 \end{bmatrix} \quad \tilde{R}_3 = \begin{bmatrix} 0 & 0 & 0 & -1 \\ 0 & 0 & -1 & 0 \\ 0 & 1 & 0 & 0 \\ 1 & 0 & 0 & 0 \end{bmatrix} \quad (4.35)$$

form the basis of a Lie algebra isomorphic to  $so(3)$ . If  $q(0)$  is a unit quaternion (i.e.,  $\bar{q}'(0)\bar{q}(0) = 1$ ), then  $\bar{q}'(t)\bar{q}(t) = 1$  for all  $t$ . Thus  $q$  evolves on the quaternion group for all  $t$ , or equivalently,  $\bar{q}$  evolves on  $S^3$ .

Thus, one can consider attitude estimation problems by using the quaternion equation (4.34), the angular velocity equation (4.3), and an

appropriate measurement equation. In the case of the strapdown navigation system of Section 4.2, equation (4.4) is again the appropriate measurement. For the star tracker, the measurement corresponding to (4.18) is

$$dz(t) = g(q(t)) \alpha(t) + S^{1/2}(t)dv(t) \quad (4.36)$$

where  $g(q)$  is defined in (4.31). Notice that this measurement is quadratic in  $q$ . As we remarked in Chapter 2, the bilinear system (4.34) with quadratic measurement (4.36) can be transformed into a bilinear system with a linear measurement by augmenting the state of (4.34).

We can again use a constrained least-squares estimation criterion for the system (4.3), (4.34) evolving on  $Q$ , with measurements  $z$  given by (4.4) or (4.36) (see also [B15] and [G3]). In this case, we wish to find the estimate  $(\tilde{q}(t|t), \tilde{\xi}(t|t))$  that minimizes

$$J = E[(\xi(t) - \tilde{\xi}(t|t))'(\xi(t) - \tilde{\xi}(t|t)) + (\bar{q}(t) - \tilde{q}(t|t))'(\bar{q}(t) - \tilde{q}(t|t)) | z^t] \quad (4.37)$$

subject to the constraint

$$\|\tilde{q}(t|t)\|^2 \triangleq \tilde{q}(t|t)' \tilde{q}(t|t) = 1 \quad (4.38)$$

The optimal estimate is then given by

$$\tilde{\xi}(t|t) = \hat{\xi}(t|t) \quad (4.39)$$

$$\tilde{q}(t|t) = \frac{\hat{q}(t|t)}{\|\hat{q}(t|t)\|} \quad (4.40)$$

where  $\hat{\cdot}$  again denotes conditional expectation.

#### 4.4 Satellite Tracking

A simplified satellite tracking problem can also be analyzed in the framework of bilinear systems. Consider a satellite in circular orbit about some celestial body. Because of a variety of effects including anomalies in the gravitational field of the body, effects of the gravitational fields of nearby bodies, and the effects of solar pressure, the orbit of the satellite is perturbed. In this case, the position  $x$  of the satellite can be described by the simplified bilinear model [W12]

$$dx(t) = \left\{ \left[ \sum_{i=1}^3 f_i(t) R_i + \frac{1}{2} \sum_{i,j=1}^3 Q_{ij}(t) R_i R_j \right] dt + \sum_{i=1}^3 R_i dw_i(t) \right\} x(t) \quad (4.41)$$

where  $f_i$  are the components of the nominal angular velocity and  $w_i$  are the components of a Wiener process with strength  $Q(t)$ . If  $E[x'(0)x(0)] = 1$ , then  $E[x'(t)x(t)] = 1$  for all  $t$ ; thus  $x$  evolves on the 2-sphere  $S^2$  (the same statement can be made almost surely [L8]). We note that the assumption in (4.41) that the perturbations in the angular velocity are white is a simplification. For example, the anomalies in the gravitational field of the celestial body are spatially correlated and constitute a random field [P2], [W8]. However, the simplified model (4.41) leads to simple but accurate on-line tracking schemes (see Chapter 6).

If we are then given noisy observations of the satellite position

$$dz(t) = H(t) x(t)dt + S^{1/2}(t) dv(t) \quad (4.42)$$

where  $v$  is a standard Wiener process and  $S(t) = S'(t) > 0$ , our problem is to estimate  $x(t)$  given  $\{z(s), 0 \leq s \leq t\}$ , and we can again use a constrained least-squares criterion. Notice that this problem is also of the bilinear system-linear observation type described in Chapter 2.

Consideration of the many practical problems described in this chapter, in addition to the theoretical questions posed in Chapter 1, has led to the study of estimation problems for similar bilinear models. These will be discussed in the next two chapters.

## CHAPTER 5

### FINITE DIMENSIONAL OPTIMAL NONLINEAR ESTIMATORS

#### 5.1 Introduction

In this chapter we will exploit the structure of particular classes of systems in order to prove that the optimal estimators for these systems are finite dimensional. The general class of systems is given by a linear Gauss-Markov process  $\xi$  which feeds forward into a nonlinear system with state  $x$ . Our goal is to estimate  $\xi$  and  $x$  given noisy linear observations of  $\xi$ . Specifically, consider the system

$$d\xi(t) = F(t)\xi(t)dt + G(t)dw(t) \quad (5.1)$$

$$dx(t) = a_0(x(t))dt + \sum_{i=1}^N a_i(x(t))\xi_i(t)dt \quad (5.2)$$

$$dz(t) = H(t)\xi(t)dt + R^{1/2}(t)dv(t) \quad (5.3)$$

where  $\xi(t)$  is an  $n$ -vector,  $x(t)$  is a  $k$ -vector,  $z(t)$  is a  $p$ -vector,  $w$  and  $v$  are independent standard Brownian motion processes,  $R > 0$ ,  $\xi(0)$  is a Gaussian random variable independent of  $w$  and  $v$ ,  $x(0)$  is independent of  $\xi(0)$ ,  $w$ , and  $v$ , and  $\{a_i, i=0, \dots, N\}$  are analytic functions of  $x$ . Also, we define  $Q(t) \triangleq G(t)G'(t)$ . It will be assumed (for technical reasons which will become evident later in this chapter) that  $[F(t), G(t), H(t)]$  is completely controllable and observable [B8].

As shown by Brockett [B25] in the deterministic case, considerable insight can be gained by considering the Volterra series expansion of the linear-analytic system (5.2). The Volterra series expansion for

the  $i^{\text{th}}$  component of  $x$  is given by

$$x_i(t) = w_{0i}(t) + \sum_{j=1}^{\infty} \int_0^t \cdots \int_0^t \sum_{k_1, \dots, k_j=1}^n w_{ji}^{(k_1, \dots, k_j)}(t, \sigma_1, \dots, \sigma_j) \cdot \xi_{k_1}(\sigma_1) \cdots \xi_{k_j}(\sigma_j) d\sigma_1 \cdots d\sigma_j \quad (5.4)$$

where the  $j^{\text{th}}$  order kernel  $w_{ji}^{(k_1, \dots, k_j)}$  is a locally bounded, piecewise continuous function. We will consider, without loss of generality, only triangular kernels which satisfy  $w_{ji}^{(k_1, \dots, k_j)}(t, \sigma_1, \dots, \sigma_j) = 0$  if  $\sigma_{\ell+m} > \sigma_m$ ;  $\ell, m = 1, 2, 3, \dots$ . We say that a kernel  $w(t, \sigma_1, \dots, \sigma_j)$  is separable if it can be expressed as a finite sum

$$w(t, \sigma_1, \dots, \sigma_j) = \sum_{i=1}^m \gamma_0^i(t) \gamma_1^i(\sigma_1) \gamma_2^i(\sigma_2) \cdots \gamma_j^i(\sigma_j) \quad (5.5)$$

Brockett [B25] discusses the convergence of (5.4) in the deterministic case, but we will not consider this question in the general stochastic case. We will be more concerned with the case in which the linear-analytic system (5.2) has a finite Volterra series--that is, the expansion (5.4) has a finite number of terms. Brockett shows that a finite Volterra series has a bilinear realization if and only if the kernels are separable. Hence, a proof similar to that of Martin [M1] of the existence and uniqueness of solutions to a bilinear system driven by the Gauss-Markov process (5.1) implies that a finite Volterra series in  $\xi$  with separable kernels is well-defined in the mean-square sense.

As discussed in Chapter 1, our objective is the computation of the conditional means  $\hat{\xi}(t|t)$  and  $\hat{x}(t|t)$ . The computation of  $\hat{\xi}(t|t)$  can be performed by the finite dimensional (linear) Kalman-Bucy filter; moreover, the conditional density of  $\xi(t)$  given  $z^t$  is Gaussian with mean  $\hat{\xi}(t|t)$  and nonrandom covariance  $P(t)$  [J1], [K1]. As discussed in Chapter 1, the computation of  $\hat{x}(t|t)$  requires in general an infinite dimensional system of equations; it is not computed as one might naively guess, merely by substituting  $\hat{\xi}(t|t)$  into (5.2) in place of  $\xi(t)$  and solving that equation. We shall prove that  $\hat{x}(t|t)$  can be computed with a finite dimensional nonlinear estimator if the  $i^{\text{th}}$  component of the solution to (5.2) can be expressed in the form

$$x_i(t) = e^{\int_0^t \xi_j(\tau) d\tau} \eta(t) \quad (5.6)$$

where  $\xi_j$  is the  $j^{\text{th}}$  component of  $\xi$  (for some  $j$ ) and  $\eta$  is a finite Volterra series in  $\xi$  with separable kernels.

It is easy to show, using Brockett's results on finite Volterra series, that each term in (5.6) can be realized by a bilinear system of the form

$$\dot{x}(t) = \xi_j(t)x(t) + \sum_{k=1}^n A_k(t)\xi_k(t)x(t) \quad (5.7)$$

where the  $A_j$  are strictly upper triangular (zero on and below the diagonal). For such systems, the Lie algebra  $\mathcal{L}_0$  is nilpotent (see (2.3)). In Section 5.3, we shall show conversely that if (5.2) is a bilinear system with  $\mathcal{L}_0$  nilpotent, its solution can be written as a finite sum of terms given by (5.6); hence, such systems also have

finite dimensional optimal estimators. These results thus generalize the results of Lo and Willsky [L2] (for the abelian case) and Willsky [W4]. The abelian discrete-time problem is also considered by Johnson and Stear [J2].

In Section 5.2 we state the major theorems concerning finite dimensional estimators for systems described by Volterra series and we give an example. Section 5.3 contains the corresponding results for bilinear systems. In Section 5.4, suboptimal estimators are constructed for some classes of systems to which the previous results do not apply.

## 5.2 A Class of Finite Dimensional Optimal Nonlinear Estimators

The first two theorems state finite dimensional estimation results for certain classes of nonlinear systems. The proofs are contained in this section and in Appendix D; an example follows.

Theorem 5.1: Consider the linear system described by (5.1), (5.3), and define the scalar-valued process

$$x(t) = e^{\int_0^t \xi_j(\tau) d\tau} \eta(t) \quad (5.8)$$

where  $\eta$  is a finite Volterra series in  $\xi$  with separable kernels. Then  $\hat{\eta}(t|t)$  and  $\hat{x}(t|t)$  can be computed with a finite dimensional system of nonlinear stochastic differential equations driven by the innovations  $d\nu(t) \triangleq dz(t) - H(t)\hat{\xi}(t|t)dt$ .

Theorem 5.2: Consider the linear system (5.1), (5.3), and define the scalar-valued processes



$$\eta(t) = \int_0^t \int_0^{\sigma_1} \dots \int_0^{\sigma_{j-1}} \xi_{k_1}(\sigma_{m_1}) \dots \xi_{k_i}(\sigma_{m_i}) \cdot \gamma_1(\sigma_1) \dots \gamma_j(\sigma_j) d\sigma_1 \dots d\sigma_j \quad (5.9)$$

$$x(t) = e^{\xi_\ell(t)} \eta(t) \quad (5.10)$$

where  $\{\gamma_i\}$  are deterministic functions of time and  $i > j$ . Then  $\hat{\eta}(t|t)$  and  $\hat{x}(t|t)$  can be computed with a finite dimensional system of non-linear stochastic equations driven by the innovations.

The distinction between Theorems 5.1 and 5.2 lies in the fact that  $i > j$  in (5.9)--i.e., there are more  $\xi_k$ 's than integrals. On the other hand, each term in the finite Volterra series in (5.8) has  $i=j$  and the  $\sigma_{m_k}$  are distinct. As Brockett [B25] remarks, we can consider (5.9) as a single term in a Volterra series if we allow the kernel to contain impulse functions. As we will show in Lemma D.2, a term (5.9) with  $i < j$  (more integrals than  $\xi_k$ 's) can be rewritten as a Volterra term with  $i=j$ , so Theorem 5.1 also applies in this case.

Proof of Theorem 5.1: We consider one term in the finite Volterra series; since the kernels are separable, we can assume without loss of generality that this term has the form

$$\eta(t) = \int_0^t \int_0^{\sigma_1} \dots \int_0^{\sigma_{j-1}} \xi_{k_1}(\sigma_1) \dots \xi_{k_j}(\sigma_j) \gamma_1(\sigma_1) \dots \gamma_j(\sigma_j) d\sigma_1 \dots d\sigma_j \quad (5.11)$$

The theorem is proved by induction on  $j$ , the order of the Volterra term

(5.11). We now give the proof for  $j=1$ ; the proof by induction is given in Appendix D.

If  $j=1$ , then

$$\eta(t) = \int_0^t \gamma_1(\sigma_1) \xi_{k_1}(\sigma_1) d\sigma_1 \quad (5.12)$$

and  $\eta(t)$  is linear function of  $\xi$ . Hence, if the state  $\xi$  of (5.1) is augmented with  $\eta$ , the resulting system is also linear. Then the Kalman-Bucy filter for the system described by (5.1), (5.3), (5.12) generates  $\hat{\xi}(t|t)$  and  $\hat{\eta}(t|t)$ . In order to prove that  $\hat{x}(t|t)$  is "finite dimensionally computable" (FDC), we need the following lemma. First we define, for  $\sigma_1, \sigma_2 \leq t$ , the conditional cross-covariance matrix

$$P(\sigma_1, \sigma_2, t) = E[(\xi(\sigma_1) - \hat{\xi}(\sigma_1|t))(\xi(\sigma_2) - \hat{\xi}(\sigma_2|t))' | z^t] \quad (5.13)$$

(where  $\hat{\xi}(\sigma|t) = E[\xi(\sigma) | z^t]$ ).

Lemma 5.1: The joint conditional density  $p_{\xi(\sigma_1), \xi(\sigma_2)}(v, v' | z^t)$  is Gaussian with nonrandom conditional cross-covariance  $P(\sigma_1, \sigma_2, t)$ --i.e.,  $P(\sigma_1, \sigma_2, t)$  is independent of  $\{z(s), 0 \leq s \leq t\}$ .

Proof: First, the conditional density is Gaussian because  $\xi^t$  and  $z^t$  are jointly Gaussian random processes. Assume  $\sigma_1 > \sigma_2$ ; then

$$\begin{aligned} & p_{\xi(\sigma_1), \xi(\sigma_2)}(v, v' | z^t) \\ &= p_{\xi(\sigma_1)}(v | \xi(\sigma_2) = v', z^t) p_{\xi(\sigma_2)}(v' | z^t) \end{aligned} \quad (5.14)$$

$$= p_{\xi(\sigma_1)}(v | \xi(\sigma_2) = v', z_{\sigma_2}^t) p_{\xi(\sigma_2)}(v' | z^t) \quad (5.15)$$

where  $z_{\sigma_2}^t = \{z(s), \sigma_2 \leq s \leq t\}$ .

Here (5.14) follows by the definition of the conditional density, and (5.15) is due to the Markov property of the process  $(\xi, z)$  [J1]. Each of the densities in (5.15) is the result of a linear smoothing operation; hence, each is Gaussian with nonrandom covariance  $P_{\sigma_1|\sigma_2}(t)$  and  $P(\sigma_2, \sigma_2, t)$ , respectively [L10]. Also, for  $\sigma > 0$ , [K12], [G8]  $P(\sigma, \sigma, t) = [P^{-1}(\sigma) + P_B^{-1}(\sigma)]^{-1}$  where  $P_B$  is the error covariance of a Kalman filter running backward in time from  $t$  to  $\sigma$ , and  $P_B^{-1}(t) \triangleq 0$ . Due to the controllability of  $[F, G]$ ,  $P(\sigma)$  is invertible for all  $\sigma > 0$  and  $P_B(\sigma)$  is invertible for all  $\sigma < t$  [W18]; consequently,  $P(\sigma, \sigma, t)$  is invertible for all  $0 < \sigma \leq t$ . By the formula for the conditional covariance of a Gaussian distribution [J1], we have for  $0 \leq \sigma_1 < \sigma_2 \leq t$

$$P_{\sigma_1|\sigma_2}(t) = P(\sigma_1, \sigma_1, t) - P(\sigma_1, \sigma_2, t) P^{-1}(\sigma_2, \sigma_2, t) P'(\sigma_1, \sigma_2, t) \quad (5.16)$$

Since  $P(\sigma_1, \sigma_2, t)$ ,  $0 \leq \sigma_1 < \sigma_2 < t$ , can be computed from (5.16), it is also nonrandom; and since we have shown previously that  $P(0, 0, t)$  is nonrandom,  $P(\sigma_1, \sigma_2, t)$  is nonrandom for all  $0 \leq \sigma_1, \sigma_2 \leq t$ . ■

This lemma allows the off-line computation of  $P(\sigma_1, \sigma_2, t)$  via the equations of Kwakernaak [K11] (for  $\sigma_1 \leq \sigma_2$ )

$$P(\sigma_1, \sigma_2, t) = P(\sigma_1) \Psi'(\sigma_2, \sigma_1) - P(\sigma_1) \left[ \int_{\sigma_2}^t \Psi'(\tau, \sigma_1) H'(\tau) R^{-1}(\tau) H(\tau) \Psi(\tau, \sigma_2) d\tau \right] P(\sigma_2) \quad (5.17)$$

$$\frac{d}{dt} \Psi(t, \tau) = [F(t) - P(t)H'(t)R^{-1}(t)H(t)] \Psi(t, \tau); \Psi(\tau, \tau) = I \quad (5.18)$$

where the Kalman filter error covariance matrix  $P(t) \triangleq P(t, t, t)$  is computed via the Riccati equation

$$\begin{aligned} \dot{P}(t) &= F(t) P(t) + P(t) F'(t) + Q(t) - P(t)H'(t)R^{-1}(t)H(t)P(t) \\ P(0) &= P_0 \end{aligned} \quad (5.19)$$

Recall that the characteristic function of a Gaussian random vector  $y$  with mean  $m$  and covariance  $P$  is given by

$$M_y(u) = E[\exp(iu'y)] = \exp[iu'm - \frac{1}{2} u'Pu] \quad (5.20)$$

Hence, by taking partial derivatives of the characteristic function (see Lemma D.1), we have

$$\begin{aligned} E^t[x(t)] &= \int_0^t \gamma_1(\sigma) E^t[e^{\xi_j^j(t)} \xi_{k_1}(\sigma)] d\sigma \\ &= \int_0^t \gamma_1(\sigma) [\hat{\xi}_{k_1}(\sigma|t) + P_{k_1,j}(\sigma, t, t)] e^{\hat{\xi}_j^j(t|t) + \frac{1}{2} P_{jj}(t)} d\sigma \\ &= \left\{ \int_0^t \gamma_1(\sigma) P_{k_1,j}(\sigma, t, t) d\sigma + E^t \left[ \int_0^t \gamma_1(\sigma) \xi_{k_1}(\sigma) d\sigma \right] \right\} \\ &\quad \cdot e^{\hat{\xi}_j^j(t|t) + \frac{1}{2} P_{jj}(t)} \\ &= \left\{ \int_0^t \gamma_1(\sigma) P_{k_1,j}(\sigma, t, t) d\sigma + \hat{\eta}(t|t) \right\} e^{\hat{\xi}_j^j(t|t) + \frac{1}{2} P_{jj}(t)} \end{aligned} \quad (5.21)$$

Since the first term in (5.21) is nonrandom and  $\hat{\eta}(t|t)$  and  $\hat{\xi}(t|t)$  can be computed with a Kalman-Bucy filter,  $\hat{x}(t|t)$  is indeed FDC for the case  $j=1$ .

The induction step of the proof of Theorem 5.1 is given in Appendix D. A crucial component of the proof is Lemma D.1, which expresses higher order moments of a Gaussian distribution in terms of the lower moments. Notice that in equation (5.21) we have interchanged the operations of integration and conditional expectation. This is justified by the version of the Fubini theorem proved in Appendix C; since we will be dealing only with integrals of products of Gaussian random processes, the use of the Fubini theorem is easily justified, and we will use it without further comment.

The proof of Theorem 5.2 is almost identical to that of Theorem 5.1; the differences are explained in Appendix D. We now present an example to illustrate the basic concepts of these theorems; this example is a special case of Theorem 5.2. However, we will need one preliminary lemma.

Lemma 5.2: The conditional cross-covariance satisfies

$$P(\sigma, t, t) = K(t, \sigma)P(t) \quad (5.22)$$

where

$$\frac{d}{dt} K'(t, \sigma) = -[F'(t) + P^{-1}(t) Q(t)] K'(t, \sigma); K'(\sigma, \sigma) = I \quad (5.23)$$

Proof: Let

$$\tilde{P}(\sigma, t) \triangleq E[(\xi(\sigma) - \hat{\xi}(\sigma|\sigma))(\xi(t) - \hat{\xi}(t|t))']$$

and consider

$$P(\sigma, t, t) - \tilde{P}(\sigma, t) = E[(\hat{\xi}(\sigma|\sigma) - \hat{\xi}(\sigma|t))(\xi(t) - \hat{\xi}(t|t))' | z^t]$$

Since  $\hat{\xi}(\sigma|\sigma) - \hat{\xi}(\sigma|t)$  is measurable with respect to the  $\sigma$ -field  $\sigma(z^t)$ , the projection theorem [R3] implies that  $P(\sigma, t, t) - \tilde{P}(\sigma, t) = 0$ . The proof is concluded by noting that [K12]

$$\tilde{P}(\sigma, t) = K(t, \sigma)P(t) \quad \blacksquare$$

Example 5.1: Consider the system described by

$$\begin{bmatrix} d\xi_1(t) \\ d\xi_2(t) \end{bmatrix} = \begin{bmatrix} -\alpha & 0 \\ 0 & -\beta \end{bmatrix} \begin{bmatrix} \xi_1(t) \\ \xi_2(t) \end{bmatrix} dt + \begin{bmatrix} dw_1(t) \\ dw_2(t) \end{bmatrix} \quad (5.24)$$

$$dx(t) = (-\gamma x(t) + \xi_1(t)\xi_2(t))dt \quad (5.25)$$

$$\begin{bmatrix} dz_1(t) \\ dz_2(t) \end{bmatrix} = \begin{bmatrix} \xi_1(t) \\ \xi_2(t) \end{bmatrix} dt + \begin{bmatrix} dv_1(t) \\ dv_2(t) \end{bmatrix} \quad (5.26)$$

where  $\alpha, \beta, \lambda > 0$ ,  $w_1, w_2, v_1$ , and  $v_2$  are independent, zero mean, unit variance Wiener processes,  $\xi_1(0)$  and  $\xi_2(0)$  are independent Gaussian random variables which are also independent of the noise processes, and  $x(0) = 0$  (see Figure 5.1).

The conditional expectation  $\hat{x}(t|t)$  satisfies the nonlinear filtering equation (1.7)-(1.8):

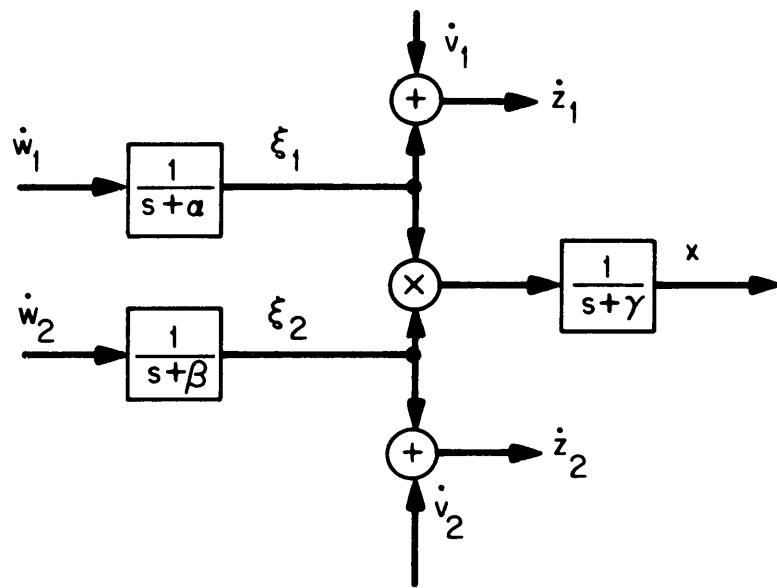

Figure 5.1 Block Diagram of the System of Example 5.1

$$\begin{aligned}
d\hat{x}(t|t) &= E^t[-\gamma x(t) + \xi_1(t) \xi_2(t)]dt \\
&+ \{E^t[\int_0^t e^{-\gamma(t-s)} \xi_1(s) \xi_2(s) ds \cdot \xi'(t)] \\
&- E^t[\int_0^t e^{-\gamma(t-s)} \xi_1(s) \xi_2(s) ds] \hat{\xi}'(t|t)\} dv(t) \quad (5.27)
\end{aligned}$$

where  $\xi(t) = [\xi_1(t), \xi_2(t)]'$  and the innovations process  $v$  is given by

$$dv(t) = dz(t) - \hat{\xi}(t|t)dt \quad (5.28)$$

Recall that the conditional covariance  $P(t)$  of  $\xi(t)$  given  $z^t$  satisfies the Riccati equation (5.19). Since  $\xi_1(0)$  and  $\xi_2(0)$  are independent, it is not difficult to show that  $P_{12}(t) = P_{21}(t) = 0$  for all  $t$ . From (5.22)-(5.23) we can compute

$$P(\sigma, t, t) = \begin{bmatrix} P_{11}(t) \exp[\alpha(t-\sigma) - \int_{\sigma}^t P_{11}^{-1}(s) ds] & 0 \\ 0 & P_{22}(t) \exp[\beta(t-\sigma) - \int_{\sigma}^t P_{22}^{-1}(s) ds] \end{bmatrix} \quad (5.29)$$

These facts and equation (D.3a) imply that the transpose of the gain term in (5.27) is

$$\begin{aligned}
&E^t[\int_0^t e^{-\gamma(t-s)} \xi_1(s) \xi_2(s) \xi(t) ds] - E^t[\int_0^t e^{-\gamma(t-s)} \xi_1(s) \xi_2(s) ds] \hat{\xi}(t|t) \\
&= \int_0^t e^{-\gamma(t-s)} (E^t[\xi_1(s) \xi_2(s) \xi(t)] - E^t[\xi_1(s) \xi_2(s)] E^t[\xi(t)]) ds \\
&= E^t \left\{ \int_0^t e^{-\gamma(t-s)} \begin{bmatrix} 0 & P_{11}(s, t, t) \\ P_{22}(s, t, t) & 0 \end{bmatrix} \begin{bmatrix} \xi_1(s) \\ \xi_2(s) \end{bmatrix} ds \right\} \quad (5.30a)
\end{aligned}$$



$$= \mathbb{E}^t \begin{bmatrix} \eta_1(t)P_{11}(t) \\ \eta_2(t)P_{22}(t) \end{bmatrix} \quad (5.30b)$$

where

$$\begin{bmatrix} \dot{\eta}_1(t) \\ \dot{\eta}_2(t) \end{bmatrix} = \begin{bmatrix} \alpha - \gamma - P_{11}^{-1}(t) & 0 \\ 0 & \beta - \gamma - P_{22}^{-1}(t) \end{bmatrix} \begin{bmatrix} \eta_1(t) \\ \eta_2(t) \end{bmatrix} + \begin{bmatrix} 0 & 1 \\ 1 & 0 \end{bmatrix} \begin{bmatrix} \xi_1(t) \\ \xi_2(t) \end{bmatrix} \quad (5.31)$$

$$\eta_1(0) = \eta_2(0) = 0$$

In other words, the argument of the conditional expectation in (5.30a) can be realized as the output of a finite dimensional linear system with state  $\eta(t) = [\eta_1(t), \eta_2(t)]'$  satisfying (5.31).

Thus the finite dimensional optimal estimator for the system (5.24)-(5.26) is constructed as follows (see Figure 5.2). First we augment the state  $\xi$  of (5.24) with the state  $\eta$  of (5.31). Then the Kalman-Bucy filter for the linear system (5.24), (5.31), with observations (5.26), computes the conditional expectations  $\hat{\xi}(t|t)$  and  $\hat{\eta}(t|t)$ . Finally,

$$\begin{aligned} d\hat{x}(t|t) &= [-\gamma\hat{x}(t|t) + \hat{\xi}_1(t|t)\hat{\xi}_2(t|t)]dt + \hat{\eta}'(t|t)P(t)d\nu(t) \\ \hat{x}(0|0) &= 0 \end{aligned} \quad (5.32)$$

We now discuss the steady-state behavior of the optimal filter. Since the linear system (5.24) is asymptotically stable (and hence detectable) and controllable, the Riccati equation (5.19) has a unique positive-definite steady state solution  $P$  [W18]; a simple computation shows that

$$P = \begin{bmatrix} P_{11} & 0 \\ 0 & P_{22} \end{bmatrix} = \begin{bmatrix} -\alpha + \sqrt{\alpha^2 + 1} & 0 \\ 0 & -\beta + \sqrt{\beta^2 + 1} \end{bmatrix} \quad (5.33)$$

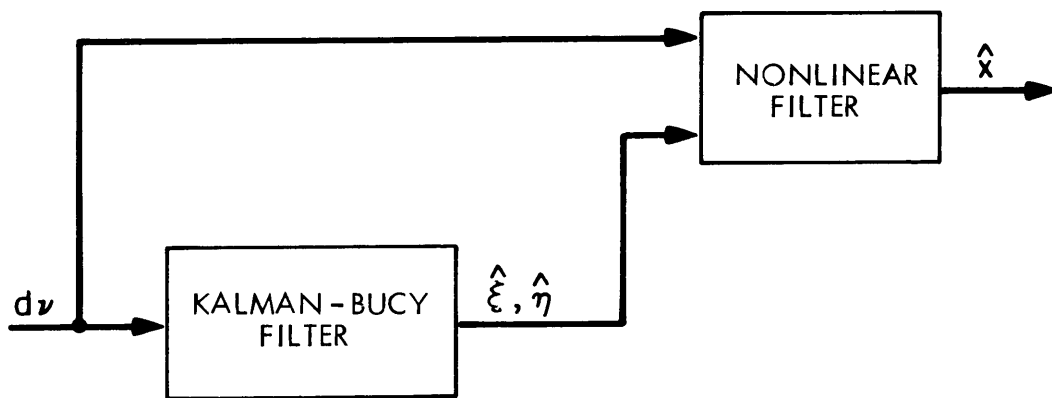

Figure 5.2 Block Diagram of the Optimal Filter for Example 5.1

Thus, in steady-state, the augmented linear system (5.24), (5.31) is time-invariant. Now consider the eigenvalues of (5.31) in steady-state:

$$\alpha - \gamma - P_{11}^{-1} = \alpha - \gamma - (-\alpha + \sqrt{\alpha^2 + 1})^{-1} = -\gamma - \sqrt{\alpha^2 + 1}$$

$$\beta - \gamma - P_{22}^{-1} = \beta - \gamma - (-\beta + \sqrt{\beta^2 + 1})^{-1} = -\gamma - \sqrt{\beta^2 + 1}$$

Consequently, the augmented linear system is also asymptotically stable and controllable in steady-state. Let the conditional covariance matrix of the augmented state  $[\xi(t), \eta(t)]$  given  $z^t$  be denoted by  $S(t)$ . Then the Riccati equation satisfied by  $S(t)$  has a unique positive-definite steady-state solution  $S$  (notice that  $S_{11} = P_{11}$  and  $S_{22} = P_{22}$ ).

The steady-state Kalman-Bucy filter [J1] for the augmented system

(5.24), (5.31) is easily computed to be

$$\begin{bmatrix} d\hat{\xi}_1(t|t) \\ d\hat{\xi}_2(t|t) \\ d\hat{\eta}_1(t|t) \\ d\hat{\eta}_2(t|t) \end{bmatrix} = \begin{bmatrix} -\alpha & 0 & 0 & 0 \\ 0 & -\beta & 0 & 0 \\ 0 & 1 & -\gamma - \sqrt{\alpha^2 + 1} & 0 \\ 1 & 0 & 0 & -\gamma - \sqrt{\beta^2 + 1} \end{bmatrix} \begin{bmatrix} \hat{\xi}_1(t|t) \\ \hat{\xi}_2(t|t) \\ \hat{\eta}_1(t|t) \\ \hat{\eta}_2(t|t) \end{bmatrix} dt + \begin{bmatrix} P_{11} & 0 \\ 0 & P_{22} \\ 0 & S_{23} \\ S_{14} & 0 \end{bmatrix} \begin{bmatrix} dv_1(t) \\ dv_2(t) \end{bmatrix} \quad (5.34)$$

where

$$S_{14} = \frac{P_{11}P_{22}}{P_{11}P_{22} + (\alpha - \beta + \gamma)P_{22} + 1}, \quad S_{23} = \frac{P_{11}P_{22}}{P_{11}P_{22} + (\beta - \alpha + \gamma)P_{11} + 1}$$

(here  $P_{11}$  and  $P_{22}$  are defined in (5.33)). The conditional expectation  $\hat{x}(t|t)$  is computed according to

$$\begin{aligned} d\hat{x}(t|t) &= [-\gamma\hat{x}(t|t) + \hat{\xi}_1(t|t)\hat{\xi}_2(t|t)]dt + \hat{\eta}'(t|t)Pdv(t) \\ \hat{x}(0|0) &= 0 \end{aligned} \quad (5.35)$$

which is a nonlinear, time-invariant equation. The steady-state optimal filter is illustrated in Figure 5.3.

We note that the stability of the original linear system is not necessary for the existence of the steady state optimal filter in this example; in fact, a weaker sufficient condition is the detectability [W18] of the linear system (5.24), (5.26) and the positivity of  $\gamma$  in (5.25). The generalization of this result to other systems is presently being investigated.

The basic technique in Example 5.1 and in the proof of Theorems 5.1 and 5.2 is the augmentation of the state of the original system with the processes which are required in the nonlinear filtering equation. For the classes of systems considered here, we prove that only a finite number of additional states are required. An alternate interpretation is that we need only compute a finite number of the smoothed statistics of  $\xi$ .

### 5.3 Finite Dimensional Estimators for Bilinear Systems

In this section we will use the results of the previous section and some results from Lie theory to prove that the optimal estimators for certain bilinear systems are finite dimensional. We note here that as early as 1965, Kalman [K10] conjectured: "It might be that algebraic methods, reminiscent of the way in which Lie groups are used to study nonlinear differential equations, will give us the first explicit, nontrivial, nonlinear filters." The results of this section will show that Kalman was, in a sense, correct.

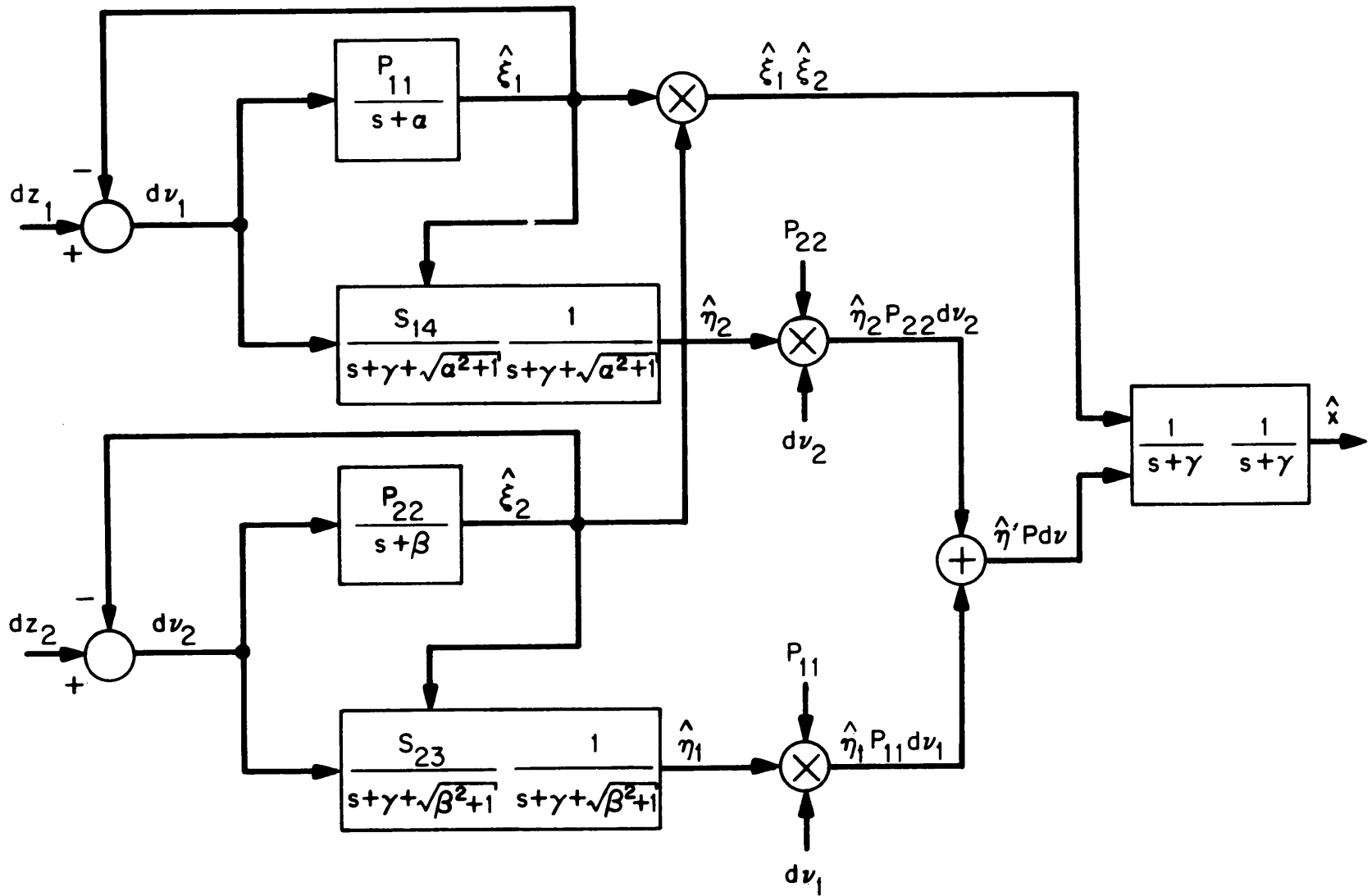

Figure 5.3 Block Diagram of the Steady-State Optimal Filter For Example 5.1

Consider the system described by (5.1), (5.3), and

$$\dot{X}(t) = (A_0 + \sum_{i=1}^N \xi_i(t)A_i)X(t); \quad X(0) = I \quad (5.36)$$

where  $X(t)$  is a  $k \times k$  matrix. We will explicitly use the structure of the Lie algebra  $\mathcal{L} = \{A_1, \dots, A_N\}_{LA}$  and the ideal  $\mathcal{L}_0$  in  $\mathcal{L}$  generated by  $\{A_1, \dots, A_N\}$  in the determination of finite dimensional estimators.

Theorem 5.3: Consider the system described by (5.1), (5.3), and (5.36), and assume that  $\mathcal{L}_0$  is nilpotent (see Appendix A). Then the conditional expectation  $\hat{X}(t|t)$  can be computed with a finite dimensional system of nonlinear stochastic differential equations driven by the innovations  $dv(t) \triangleq dz(t) - H(t)\hat{\xi}(t|t)dt$ .

It can easily be shown that if  $\mathcal{L}_0$  is nilpotent, then  $\mathcal{L}$  is solvable; however, the converse is not true. Hence,  $\mathcal{L}$  is always solvable in Theorem 5.3.

Notice that the model considered in Theorem 5.3 is the same as the strapdown navigation model of Section 4.2. However, in the navigation model  $\mathcal{L} = SO(3)$  is not solvable (in fact, it is simple), so Theorem 5.3 does not apply. Suboptimal estimation techniques which can be applied to the navigation problem are discussed in Section 5.4.

Theorem 5.3 is proved via a series of lemmas which reduce the estimation problem to the case in which  $\mathcal{L}$  is a particular nilpotent Lie algebra. The first lemma generalizes a result of Willsky [W4], Brockett [B1], and Krener [K6] (the proof is analogous and will be omitted).

Lemma 5.3: Consider the system (5.1), (5.3), (5.36), and define the  $k \times k$  matrix-valued process

$$Y(t) = e^{-A_0 t} X(t)$$

Then there exists a deterministic matrix-valued function  $D(t)$  such that  $Y$  satisfies

$$\dot{Y}(t) = \left[ \sum_{i=1}^M H_i y_i(t) \right] Y(t); \quad Y(0) = I \quad (5.37)$$

where  $\{H_1, \dots, H_M\}$  is a basis for  $\mathcal{L}_0$  and

$$y(t) = D(t)\xi(t) \quad (5.38)$$

In addition,  $\hat{X}$  can be computed according to

$$\hat{X}(t|t) = e^{A_0 t} \hat{Y}(t|t) \quad (5.39)$$

Lemma 5.3 enables us, without loss of generality, to examine the estimation problem for  $Y(t)$  evolving on the normal subgroup  $G_0 = \{\exp \mathcal{L}_0\}_G$ , rather than for  $X(t)$  evolving on the full Lie group  $G = \{\exp \mathcal{L}\}_G$ . Thus we need only consider the case in which  $A_0 = 0$  and  $\mathcal{L} = \mathcal{L}_0$  is nilpotent in order to prove Theorem 5.3.

By means of Lemma A.2, the problem can be further reduced to the consideration of Lie algebras in nilpotent canonical form (see equation (A.6)).

Lemma 5.4: Consider the system (5.1), (5.3), (5.36), where  $A_0 = 0$  and  $\mathcal{L}$  is nilpotent. Then there exists a (possibly complex-valued) non-singular matrix  $P$  such that

$$\hat{X}(t|t) = P^{-1}\hat{Y}(t|t)P \quad (5.40)$$

where  $Y$  satisfies (5.37) and  $\{H_1, \dots, H_M\}$  are in nilpotent canonical form.

Proof: According to Lemma A.2, there exists a nonsingular matrix  $P$  such that  $P \mathcal{L} P^{-1}$  is in nilpotent canonical form. If we define  $H_i = PA_iP^{-1}$ , then  $X(t) = P^{-1}Y(t)P$ , where  $Y$  satisfies (5.37). Hence  $\hat{X}(t|t) = P\hat{Y}(t|t)P^{-1}$  and the lemma is proved. ■

Finally, by means of the following trivial lemma, we reduce the problem to the consideration of one block in the nilpotent canonical form.

Lemma 5.5: Consider the system (5.1), (5.3), (5.36), where  $A_0 = 0$  and  $\{A_1, \dots, A_N\}$  are in nilpotent canonical form. Then  $X(t)$  has a block diagonal form conformable with that of  $\{A_1, \dots, A_N\}$ .

Let  $\mathfrak{gn}(m)$  denote the Lie algebra of upper triangular  $m \times m$  matrices with equal diagonal elements. Then Lemma 5.5 implies that the bilinear system (5.36) can be viewed as the "direct sum" of a number of decoupled  $k_j$ -dimensional subsystems

$$\dot{X}^j(t) = \left[ \sum_{i=1}^N \xi_i(t) A_i^j \right] X^j(t); \quad X^j(0) = I$$

where  $A_1^j, \dots, A_N^j$  belong to  $\mathfrak{gn}(k_j)$ . Hence Theorem 5.3 will be established when we prove the following lemma.



Lemma 5.6: Consider the system (5.1), (5.3), (5.36), where  $A_0 = 0$  and  $\{A_1, \dots, A_N\} \in \text{gn}(k)$ . Then each element of the solution  $X(t)$  of (5.36) can be expressed in the form

$$\exp \left( \sum_{i=1}^N \alpha_i \int_0^t \xi_i(s) ds \right) \eta(t) \quad (5.41)$$

where  $\eta$  is a finite Volterra series in  $\xi$  with separable kernels. Hence, Theorem 5.1 implies that  $\hat{X}(t|t)$  can be computed with a finite dimensional system of nonlinear stochastic differential equations.

Proof: Since  $\{A_1, \dots, A_N\} \in \text{gn}(k)$ , the bilinear equation (5.36) can be rewritten in the form

$$\dot{X}(t) = \left[ \left( \sum_{i=1}^N \alpha_i \xi_i(t) \right) I + \sum_{i=1}^N \xi_i(t) B_i \right] X(t) \quad (5.42)$$

where  $\alpha_i$  are constants,  $I$  denotes the  $k \times k$  identity matrix, and  $B_1, \dots, B_N$  are strictly upper triangular (zero on the diagonal). It is easy to show that

$$X(t) = \exp \left( \sum_{i=1}^N \alpha_i \int_0^t \xi_i(s) ds \right) Y(t)$$

where  $Y$  satisfies

$$\dot{Y}(t) = \left[ \sum_{i=1}^N \xi_i(t) B_i \right] Y(t); \quad Y(0) = I \quad (5.43)$$

Since the  $\{B_i\}$  are strictly upper triangular, the solution of (5.43) can be written as a finite Peano-Baker (Volterra) series [B25], and each element of  $X(t)$  can be expressed in the form (5.41). ■

Theorem 5.3 can be generalized to include certain time-varying bilinear systems; the proof is identical.

Theorem 5.4: Consider the system described by (5.1), (5.3) and

$$\dot{X}(t) = [A_0(t) + \sum_{i=1}^N \xi_i(t)A_i]X(t); X(0) = I \quad (5.44)$$

Let  $\mathcal{L} = \{A_1, \dots, A_N, A_0(t) (\forall t)\}_{LA}$ , and let  $\mathcal{L}_0$  be the ideal in  $\mathcal{L}$  generated by  $\{A_1, \dots, A_N\}$ . Assume that  $\mathcal{L}_0$  is nilpotent. Then  $\hat{X}(t|t)$  can be computed with a finite dimensional system of nonlinear stochastic differential equations.

We note that if  $A_0(t)$  is time-varying, the nilpotency of  $\mathcal{L}_0$  does not imply that  $\mathcal{L}$  is solvable. Hence, in contrast to Theorem 5.3,  $X(t)$  in Theorem 5.4 need not evolve on a solvable Lie group.

The following example illustrates how Hirschorn's bilinearization technique (see Chapter 2) can be used to place the series interconnection of two bilinear systems in the framework of Theorem 5.3.

Example 5.2: Consider the series interconnection of two bilinear systems described by [H2]

$$\dot{x}_1(t) = [A_0 + \xi_1(t)A_1 + \xi_2(t)A_2]x_1(t); \quad x_1(0) = x_{10} \quad (5.45)$$

$$\dot{x}_2(t) = [B_0 + Cx_1(t)B_1]x_2(t); \quad x_2(0) = x_{20} \quad (5.46)$$

where  $x_1 \in \mathbb{R}^3$ ,  $x_2 \in \mathbb{R}^3$ ,  $C = [0,1,1]$ , and

$$\begin{aligned}
A_0 &= \begin{bmatrix} 1 & 1 & 0 \\ 0 & 1 & 0 \\ 0 & 0 & 0 \end{bmatrix} & A_1 &= \begin{bmatrix} 0 & 1 & 0 \\ 0 & 0 & 1 \\ 0 & 0 & 0 \end{bmatrix} & A_2 &= \begin{bmatrix} 0 & 0 & 1 \\ 0 & 0 & 0 \\ 0 & 0 & 0 \end{bmatrix} \\
B_0 &= \begin{bmatrix} 0 & 1 & 0 \\ 0 & 0 & 0 \\ 0 & 0 & 0 \end{bmatrix} & B_1 &= \begin{bmatrix} 0 & 0 & 0 \\ 0 & 0 & 1 \\ 0 & 0 & 0 \end{bmatrix}
\end{aligned} \tag{5.47}$$

Hirschorn shows that the system (5.45)-(5.46) can be bilinearized--i.e., there exists an 8x8 matrix bilinear system

$$\dot{X}(t) = [F_0 + \xi_1(t)F_1 + \xi_2(t)F_2]X(t); \quad X(0) = I \tag{5.48}$$

such that  $y(t) = [x_1'(t), x_2'(t)]'$  is given by

$$y(t) = [I_6 \quad 0]X(t) \begin{bmatrix} y(0) \\ y_3(0)y_6(0) \\ y_2(0)y_6(0) \end{bmatrix} \tag{5.49}$$

In addition,  $\mathcal{L} = \{F_0, F_1, F_2\}_{LA}$  is nilpotent. Thus in this case the bilinearization of (5.45)-(5.46) is accomplished merely by augmenting the state  $y$ ; the augmented system is in fact bilinear. If the initial state  $y(0)$  is assumed to be independent of  $\xi_1(t)$  and  $\xi_2(t)$  for all  $t$ , then

$$\hat{y}(t|t) = [I_6 \quad 0]\hat{X}(t|t) \begin{bmatrix} E[y(0)] \\ E[y_3(0)y_6(0)] \\ E[y_2(0)y_6(0)] \end{bmatrix} \tag{5.50}$$

Since  $\mathcal{L}$  is nilpotent, Theorem 5.3 implies that  $\hat{X}(t|t)$ , and hence  $\hat{y}(t|t)$ , are computable with a finite dimensional filter.

This is a very simple example, the results of which could also have been obtained by solving (5.45)-(5.46) explicitly and applying Theorem 5.1. In general, one must be careful in applying techniques such as bilinearization to estimation problems. Notice that the action (5.49) of  $X(t)$  on  $y(0)$  is linear in  $X(t)$ ; if it had been nonlinear (as is the case for a general bilinearization problem [H2]), the method would not have worked. Also, recall from Section 2.1 that the Lie group  $G(D)$  associated with the nonlinear system (see equation (2.9)) may not have a matrix representation; in such cases, the procedure of Example 3.2 cannot be used.

#### 5.4 General Linear-Analytic Systems--Suboptimal Estimators

In this section we present an example to demonstrate that the results of the previous sections cannot be generalized to much larger classes of systems; in fact, we will show that Theorem 5.3 cannot even be generalized to the case in which  $\mathcal{L}$  is solvable, but  $\mathcal{L}_0$  is not nilpotent. We will then present a suboptimal estimation procedure for linear-analytic systems driven by colored noise.

Example 5.3: Consider the estimation of  $X$  with observations  $z$ , as described in (5.1), (5.3), (5.36), in which  $\mathcal{L}_0$  is the most elementary non-nilpotent Lie algebra. That is, let  $n = N = 3$ ,  $k = 2$ ,  $A_0 = 0$ , and

$$A_1 = \begin{bmatrix} 1 & 0 \\ 0 & 0 \end{bmatrix} \quad A_2 = \begin{bmatrix} 0 & 1 \\ 0 & 0 \end{bmatrix} \quad A_3 = \begin{bmatrix} 0 & 0 \\ 0 & 1 \end{bmatrix} \quad (5.51)$$

The solution of (5.36) can then be expressed in closed form as

$$X(t) = \begin{bmatrix} y_1(t) & \int_0^t \xi_2(\tau) e^{\eta(\tau,t)} d\tau \\ e & y_3(t) \\ 0 & e \end{bmatrix} \quad (5.52)$$

where

$$\eta(\tau,t) = \int_{\tau}^t \xi_1(\sigma) d\sigma + \int_0^{\tau} \xi_3(\sigma) d\sigma \quad (5.53)$$

and

$$y_i(t) = \int_0^t \xi_i(\sigma) d\sigma \quad (5.54)$$

Using the characteristic function (5.20), we see that

$$\hat{X}_{11}(t|t) = \exp[\hat{y}_1(t|t) + \frac{1}{2} \int_0^t \int_0^t P_{11}(\sigma_1, \sigma_2, t) d\sigma_2 d\sigma_1] \quad (5.55)$$

$$\hat{X}_{22}(t|t) = \exp[\hat{y}_3(t|t) + \frac{1}{2} \int_0^t \int_0^t P_{33}(\sigma_1, \sigma_2, t) d\sigma_2 d\sigma_1] \quad (5.56)$$

Thus the only difficulty is in the computation of  $\hat{X}_{12}(t|t)$ . But

$$\hat{X}_{12}(t|t) = \int_0^t E^t[\xi_2(\tau) e^{\eta(\tau,t)}] d\tau \quad (5.57)$$

and, by Lemma D.1,

$$\begin{aligned} E^t[\xi_2(\tau) e^{\eta(\tau,t)}] &= [\hat{\xi}_2(\tau|t) + \alpha(\tau,t)] \cdot \\ &\quad \cdot \exp\left[\int_{\tau}^t \hat{\xi}_1(\sigma|t) d\sigma + \int_0^{\tau} \hat{\xi}_3(\sigma|t) d\sigma + \beta(\tau,t)\right] \end{aligned} \quad (5.58)$$

where

$$\alpha(\tau,t) = \int_{\tau}^t P_{12}(\sigma, \tau, t) d\sigma + \int_0^{\tau} P_{32}(\sigma, \tau, t) d\sigma \quad (5.59)$$

$$\begin{aligned}
\beta(\tau, t) = & \frac{1}{2} \int_{\tau}^t \int_{\tau}^t P_{11}(\sigma_1, \sigma_2, t) d\sigma_2 d\sigma_1 + \frac{1}{2} \int_0^{\tau} \int_0^{\tau} P(\sigma_1, \sigma_2, t) d\sigma_2 d\sigma_1 \\
& + \int_{\tau}^t \int_0^{\tau} P_{13}(\sigma_1, \sigma_2, t) d\sigma_2 d\sigma_1
\end{aligned} \tag{5.60}$$

After substituting (5.58) into (5.57), it is clear that  $\hat{X}_{12}(t|t)$  cannot be computed with a finite dimensional system of equations; i.e., we must compute an infinite number of smoothed functionals of  $\xi$ . Thus even the least complicated non-nilpotent case does not fit into the framework of the previous sections.

For the system of Example 5.3 and for other nonlinear systems which require infinite dimensional optimal estimators, implementable suboptimal estimators must be designed. A general suboptimal estimation procedure is suggested by the finite dimensional estimators developed in this chapter. Consider the system (5.1)-(5.3), and assume that the linear-analytic system (5.2) admits a Volterra series representation. Brockett [B25] shows that the Volterra kernels of a linear-analytic realization are necessarily separable. It is clear from Theorem 5.1 that a finite dimensional suboptimal estimator for  $\hat{x}(t|t)$  can be constructed by truncating the Volterra series after a finite number of terms and computing the conditional expectation of the resulting finite Volterra series. Notice, however, that the dimension of the estimator increases rapidly with the number of terms retained.

As an example of this procedure, consider the strapdown inertial navigation system of Section 4.2, as described by (4.1), (4.3), and

and (4.4). Since (4.1) evolves on the simple Lie group  $SO(3)$ , which is not even solvable, the computation of  $\hat{X}(t|t)$  requires an infinite dimensional estimator. The Volterra expansion of (4.1) is given by the Peano-Baker series [B8]

$$\begin{aligned}
 X(t) = I - & \sum_{i=1}^3 R_i \int_0^t \xi_i(\sigma_1) d\sigma_1 \\
 & + \sum_{i=1}^3 \sum_{j=1}^3 R_i R_j \int_0^t \int_0^{\sigma_1} \xi_i(\sigma_1) \xi_j(\sigma_2) d\sigma_2 d\sigma_1 - \dots \quad (5.61)
 \end{aligned}$$

A suboptimal filter for the constrained least-squares estimate (see Section 4.2) is obtained by truncating the series after  $N$  terms and computing the conditional expectation  $\bar{X}(t|t)$  of this finite series;  $\bar{X}(t|t)$  is an approximation to the true conditional expectation  $\hat{X}(t|t)$ . The finite dimensional approximation to the constrained least-squares estimate is (see (4.22))

$$\tilde{X}(t|t) = \bar{X}(t|t) [\bar{X}(t|t)' \bar{X}(t|t)]^{-1/2} \quad (5.62)$$

An analogous suboptimal estimator can also be designed for a strapdown inertial navigation system using quaternions (see Section 4.3).

In the next chapter, we present another class of suboptimal estimators which are derived by means of some concepts from harmonic analysis.

## CHAPTER 6

### THE USE OF HARMONIC ANALYSIS IN SUBOPTIMAL FILTER DESIGN

#### 6.1 Introduction

In this chapter we will study the bilinear system-linear measurement estimation problem discussed at the end of Chapter 2. As discussed there, the equations (2.30) for the computation of the conditional moments of  $x$  are coupled, and thus represent an infinite dimensional estimator for  $\hat{x}(t|t)$ . The purpose of this chapter is the design of suboptimal estimators in the case that the bilinear system evolves on a compact Lie group or homogeneous space.

The technique for suboptimal filter design developed here involves the use of harmonic analysis on the appropriate Lie group or homogeneous space (see Appendix B); thus we will explicitly take into account the structure of the system. Several authors have used a similar approach for systems defined on the circle  $S^1$  [B9], [B14], [B19], [M9], [W6]. Our approach is a generalization of that of Willsky [W6], whose work will be summarized in the next section. The technique of this chapter is also related to the generalized least-square approximation method of Center [C1].

The basic approach involves the definition of an "assumed density" form for the conditional density of  $x(t)$  given observations up to time  $t$  (see Chapter 1). Our method differs from most previous assumed density approximations in that our approximation is defined on the appropriate compact manifold (as opposed to Gaussian approximations, for example,



which are defined on  $R^n$ ). The assumed density will be defined by an expansion in terms of the eigenfunctions of the Laplace-Beltrami operator on the manifold (see Section B.4).

The use of harmonic analysis will be motivated by a phase-tracking example of Willsky [W6] in Section 6.2. In Section 6.3, we discuss the general problem and show that we need only consider systems evolving on the special orthogonal group  $SO(n)$  and the  $n$ -sphere  $S^n$ . Section 6.4 contains the application of the technique to systems evolving on  $S^n$ , while Section 6.5 contains the application to systems on  $SO(n)$ .

## 6.2 A Phase Tracking Problem on $S^1$

We first discuss a phase tracking problem studied by Bucy, et al, [B9], and Willsky [W6], in which the phase  $\theta$  and the observation  $z$  are described by

$$d\theta(t) = \omega_c dt + q^{1/2}(t) dw(t), \quad \theta(0) = \theta_0 \quad (6.1)$$

$$dz(t) = \sin \theta(t) dt + r^{1/2}(t) dv(t) \quad (6.2)$$

where  $v$  and  $w$  are independent standard Brownian motion processes independent of the random initial phase  $\theta_0$ . We wish to estimate  $\theta(t) \bmod 2\pi$  given  $z^t$ , and we take as our optimal estimation criterion the minimization of

$$E[(1 - \cos(\theta(t) - \tilde{\theta}(t))) | z(s), 0 \leq s \leq t] \quad (6.3)$$

Noting that we are essentially tracking a point on the unit circle  $S^1$  (a Lie group), we reformulate the problem in Cartesian coordinates.

Let

$$x_1 = \sin \theta(t), \quad x_2 = \cos \theta(t) \quad (6.4)$$

Then

$$\begin{bmatrix} dx_1(t) \\ dx_2(t) \end{bmatrix} = \begin{bmatrix} -q(t) dt/2 & \omega_c dt + q^{1/2}(t) dw(t) \\ -(\omega_c dt + q^{1/2}(t) dw(t)) & -q(t) dt/2 \end{bmatrix} \begin{bmatrix} x_1(t) \\ x_2(t) \end{bmatrix} \quad (6.5)$$

$$dz(t) = x_1(t) dt + r^{1/2}(t) dv(t) \quad (6.6)$$

which are of the bilinear process - linear measurement type discussed in Chapters 2 and 4.

In Cartesian coordinates our estimation problem is to choose an estimate  $(\tilde{x}_1(t), \tilde{x}_2(t))$  on the unit circle - i.e., such that

$$\tilde{x}_1^2(t) + \tilde{x}_2^2(t) = 1 \quad (6.7)$$

If we use the least squares criterion

$$J = \frac{1}{2} E[(x_1(t) - \tilde{x}_1(t))^2 + (x_2(t) - \tilde{x}_2(t))^2 | z(s), 0 \leq s \leq t] \quad (6.8)$$

subject to (6.7), or equivalently subject to

$$\tilde{x}_1(t) = \sin \tilde{\theta}(t), \quad \tilde{x}_2(t) = \cos \tilde{\theta}(t) \quad (6.9)$$

our criterion reduces to

$$J = E[1 - \cos(\theta(t) - \tilde{\theta}(t)) | z(s), 0 \leq s \leq t] \quad (6.10)$$

Thus (6.10) represents a constrained least-squares criterion of the type discussed in Chapter 4. One can show [B9], [W6] that

$$(\tilde{x}_1(t), \tilde{x}_2(t)) = \frac{(\hat{x}_1(t|t), \hat{x}_2(t|t))}{\sqrt{\hat{x}_1^2(t|t) + \hat{x}_2^2(t|t)}} \quad (6.11)$$

or

$$\tilde{\theta}(t) = \tan^{-1} \frac{\hat{x}_1(t|t)}{\hat{x}_2(t|t)} \quad (6.12)$$

where

$$\hat{x}_i(t|t) = E[x_i(t) | z(s), 0 \leq s \leq t] \quad (6.13)$$

Referring to Figure 6.1 we can see the geometric significance of this criterion. One can show that

$$P(t) \triangleq \frac{\Delta}{\sqrt{\hat{x}_1^2(t|t) + \hat{x}_2^2(t|t)}} \leq 1 \quad (6.14)$$

and the quantity  $P(t)$  is a measure of our confidence in our estimate. Specifically, if  $\theta$  is a normal random variable with variance  $\gamma$ , then (see [W2], [W6])

$$P = \sqrt{[E(\sin \theta)]^2 + [E(\cos \theta)]^2} = e^{-\gamma/2} \quad (6.15)$$

so  $\gamma = 0$  (perfect knowledge of  $\theta$ )  $\Rightarrow P = 1$

and  $\gamma = \infty$  (no knowledge)  $\Rightarrow P = 0$ .

As discussed in [B9] and [W6], the optimal (constrained least-squares) filter is described as follows. The conditional probability density of  $\theta$  given  $\{z(s), 0 \leq s \leq t\}$  may be expanded in the Fourier series (notice that the trigonometric polynomials are eigenfunctions of the Laplacian on  $S^1$ )

$$p(\theta, t) = \sum_{n=-\infty}^{+\infty} c_n(t) e^{in\theta} \quad (6.16)$$

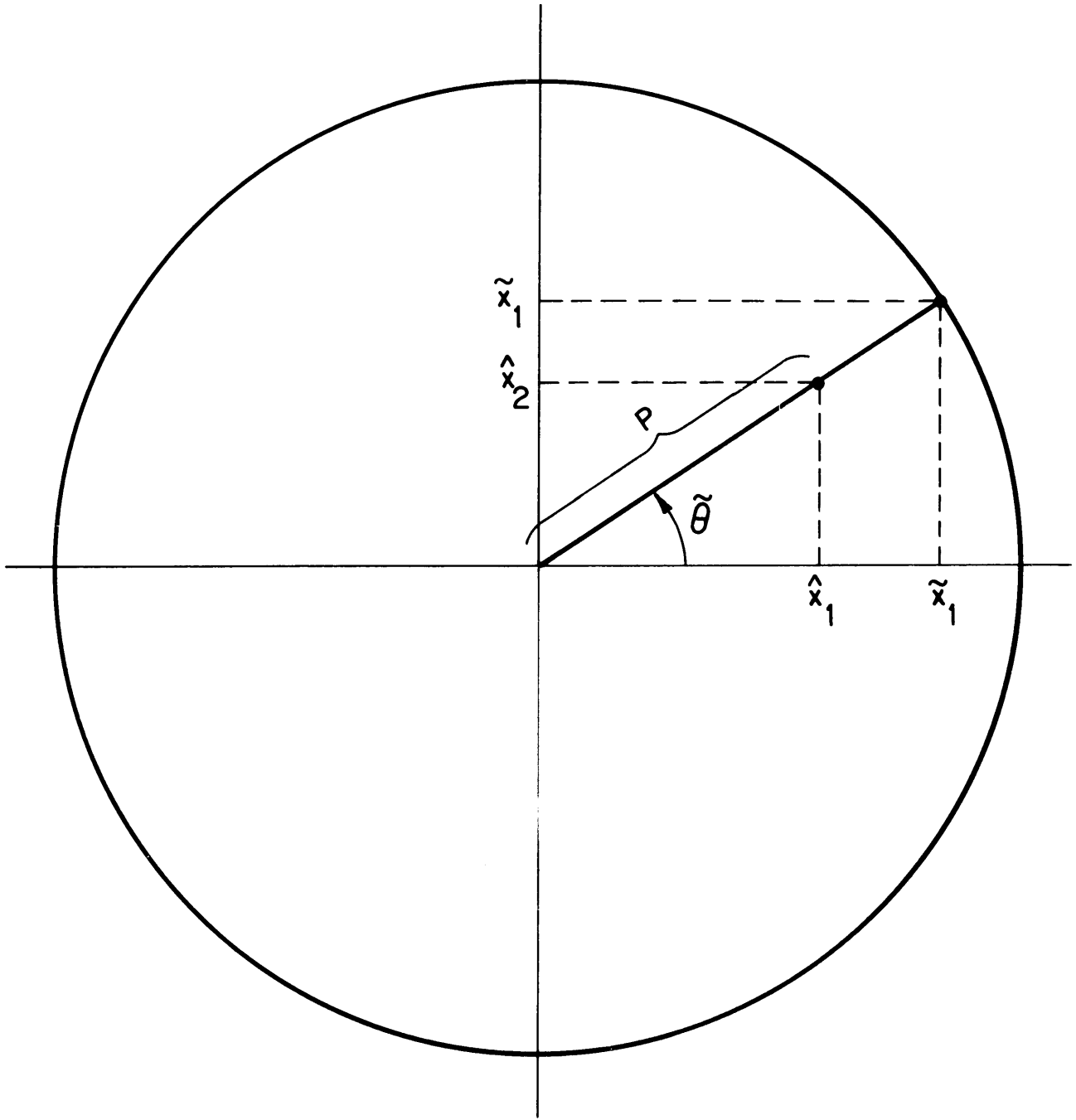

Figure 6.1 Illustrating the Geometric Interpretation of the Criterion  $E[1-\cos(\theta-\tilde{\theta})]$

where

$$c_n(t) \triangleq \frac{1}{2\pi} E[e^{-in\theta(t)} | z(s), 0 \leq s \leq t]$$

$$\triangleq b_n(t) - ia_n(t) \quad (6.17)$$

Then the optimal filter is given by

$$dc_n(t) = -[in\omega_c + \frac{n^2}{2} q(t)]c_n(t)dt$$

$$+ \left[ \frac{c_{n-1}(t) - c_{n+1}(t)}{2i} + 2\pi c_n(t) \text{Im}(c_1(t)) \right] \left[ \frac{dz(t) + 2\pi \text{Im}(c_1(t)) dt}{r(t)} \right] \quad (6.18)$$

$$\tilde{\theta}(t) = \tan^{-1}(a_1(t)/b_1(t)) \quad (6.19)$$

Since  $c_0 = \frac{1}{2\pi}$  and  $c_{-n} = c_n^*$  (where \* denotes the complex conjugate), we need only solve (6.18) for  $n \geq 1$ . The structure of the optimal filter deserves further comment [W6] (see Figure 6.2). The filter consists of an infinite bank of filters, the  $n^{\text{th}}$  of which is essentially a damped oscillator, with oscillator frequency  $n\omega_c$ , together with nonlinear couplings to the other filters and to the received signal. Notice, however, that the equation for  $c_n$  is coupled only to the filters for  $c_1$ ,  $c_{n-1}$ , and  $c_{n+1}$ . This fact will play an important part in our approximation.

In order to construct a finite-dimensional suboptimal filter, we wish to approximate the conditional density (6.16) by a density determined by a finite set of parameters. Several examples

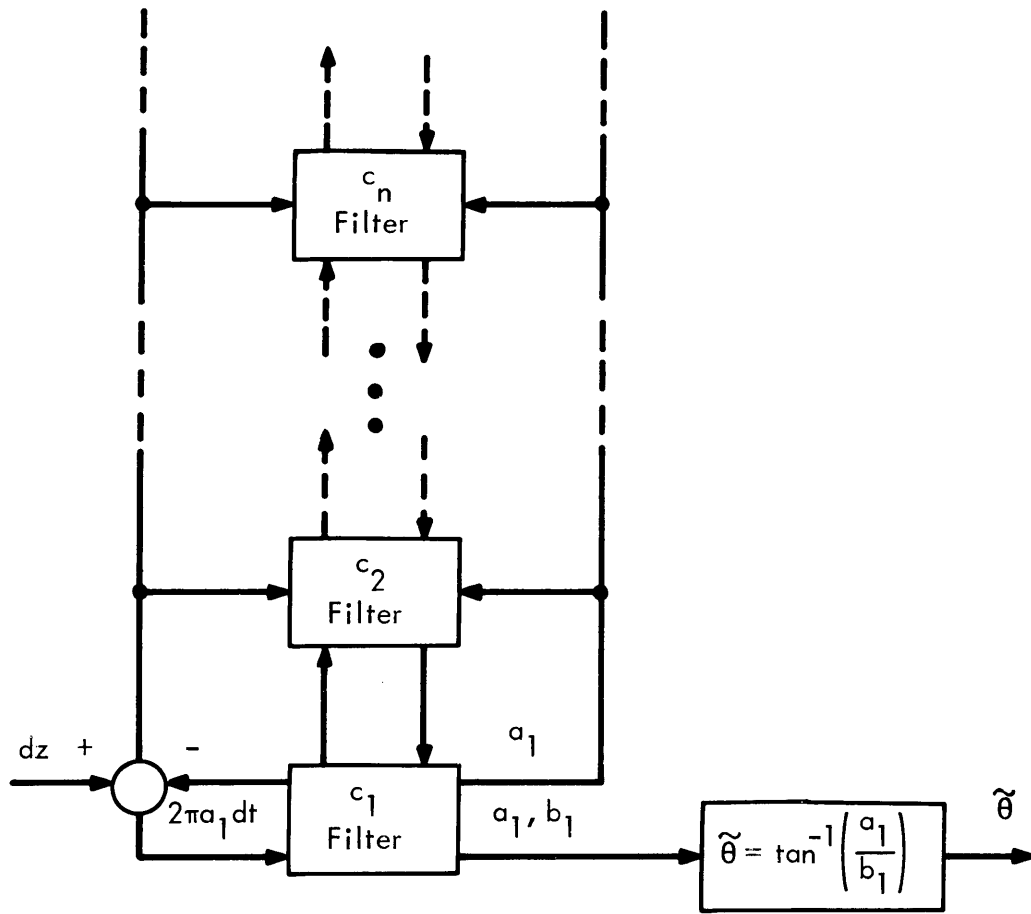

Figure 6.2 Illustrating the Form of the Infinite Dimensional Optimal Filter (6.18)-(6.19)

of "assumed density" approximations for this problem are discussed in [W2], [W6], but we will concentrate on one that involves the assumption that  $p(\theta, t)$  is a folded normal density with mode  $\eta(t)$  and "variance"  $\gamma(t)$ :

$$p(\theta, t) = \frac{1}{2\pi} \sum_{n=-\infty}^{+\infty} e^{-n^2 \gamma(t)/2} e^{in(\theta - \eta(t))} = F(\theta; \eta(t), \gamma(t)) \quad (6.20)$$

The folded normal density is the solution of the standard diffusion equation on the circle (i.e., it is the density for  $S^1$  Brownian motion processes) and is as important a density on  $S^1$  as the normal is on  $R^1$ ; we will discuss this point in more detail in the next section.

In this case, if  $c_1$  has been computed and if  $p(\theta, t)$  satisfies (6.20) then  $c_{N+1}$  can be computed (for any  $N$ ) from the equation

$$c_{N+1} = (2\pi)^{(N+1)^2 - 1} |c_1|^{N(N+1)} c_1^{(N+1)} \quad (6.21)$$

Thus we can truncate the bank of filters described by (6.18) by approximating  $c_{N+1}$  by (6.21) and substituting this approximation into the equation for  $c_N$ . This was done for  $N=1$  in [W6], and the resulting Fourier coefficient filter (FCF) was compared to a phase-lock loop and to the Gustafson-Speyer "state-dependent noise filter" (SDNF) [G2]. The FCF performed consistently better than the other systems, although the SDNF performance was quite close.

### 6.3 The General Problem

The remainder of this chapter will be devoted to the study of the estimation problem for the following systems, which are generalizations

of the phase tracking problem. The first system consists of the bilinear state equation

$$dX(t) = [A_0 + \frac{1}{2} \sum_{i,j=1}^N Q_{ij}(t)A_iA_j]X(t)dt + \sum_{i=1}^N A_iX(t)dw_i(t) \quad (6.22)$$

with linear measurements

$$dz_1(t) = X(t)h(t)dt + R^{1/2}(t)dv(t) \quad (6.23)$$

where  $X(t)$  and  $\{A_i\}$  are  $n \times n$  matrices,  $z_1(t)$  is a  $p$ -vector,  $w$  is a Wiener process with strength  $Q(t) \geq 0$ ,  $v$  is a standard Wiener process independent of  $w$ , and  $R > 0$ . More general linear measurements can obviously be considered, but for simplicity of notation we restrict our attention to (6.23), which arises in the star tracking example of Chapter 4. We also assume that the Lie group  $G = \{\exp \mathcal{L}\}_G$  is compact; hence, Theorem B.3 implies that there is a symmetric positive definite matrix  $P$  such that, for all  $t$ ,

$$X'(t)PX(t) = P \quad (6.24)$$

In addition, it is shown in [D5] that this is true if and only if

$$A'P + PA = 0 \quad \text{for all } A \in \mathcal{L} \quad (6.25)$$

In particular  $\{A_0, A_1, \dots, A_N\}$  satisfy (6.25).

Another way to derive (6.24) from (6.25) is through the use of Ito's differential rule [J1], [W8]. Assuming that  $\{A_0, A_1, \dots, A_N\}$  satisfy (6.25), we see that



$$\begin{aligned}
dX'PX &= X' \left[ (A'_0 + \frac{1}{2} \sum_{i,j=1}^N Q_{ij} A'_i A'_j) P + P (A_0 + \frac{1}{2} \sum_{i,j=1}^N Q_{ij} A_i A_j) \right] X dt \\
&+ \sum_{i=1}^N X' (A'_i P + P A_i) X dw_i \\
&+ \sum_{i,j=1}^N Q_{ij} X' A'_i P A'_j X dt
\end{aligned} \tag{6.26}$$

The last term in (6.26) is the correction term from Ito's differential rule (it is computed using the rule  $dw_i(t)dw_j(t) = Q_{ij}(t)dt$ ). The identity (6.25) implies that  $d(X'PX) = 0$ ; hence, if  $X'(0)PX(0) = P$ , then  $X'(t)PX(t) = P$  for all  $t$ .

The second system consists of the bilinear state equation

$$dx(t) = \left[ A_0 + \frac{1}{2} \sum_{i,j=1}^N Q_{ij}(t) A_i A_j \right] x(t) dt + \sum_{i=1}^N A_i x(t) dw_i(t) \tag{6.27}$$

with linear measurements

$$dz_2(t) = H(t)x(t)dt + R^{1/2}(t)dv(t) \tag{6.28}$$

where  $x(t)$  is an  $n$ -vector,  $\{A_i\}$  are  $n \times n$  matrices, and  $z_2$ ,  $v$ , and  $w$  are as above. We assume that  $x$  evolves on a compact homogeneous space.

The solution of (6.28) is

$$x(t) = X(t)x(0) \tag{6.29}$$

where  $X$  satisfies (6.22) with  $X(0) = I$ . Since  $x$  evolves on a compact homogeneous space,  $X$  must evolve on a compact Lie group; thus  $X(t)$  satisfies (6.24) for all  $t$  and  $\{A_0, A_1, \dots, A_N\}$  satisfy (6.25). Then

$$\mathbf{x}'(t)P\mathbf{x}(t) = \mathbf{x}'(0)X'(t)PX(t)\mathbf{x}(0) = \mathbf{x}'(0)P\mathbf{x}(0) \quad (6.30)$$

so the homogeneous space on which  $\mathbf{x}$  evolves is of the form  $\mathbf{x}'P\mathbf{x} = \text{constant}$ . This conclusion could also be reached by using Ito's differential rule and (6.25) as above.

We now show that we need only consider systems evolving on the Lie group  $SO(n) \triangleq \{X \in R^{n \times n} | X'X = I\}$  and the homogeneous space  $S^n \triangleq \{x \in R^n | x'x = 1\}$ , the  $n$ -sphere. First consider  $X$  satisfying (6.22) and (6.24), and define  $Y$  by

$$Y(t) = P^{1/2}X(t)P^{-1/2} \quad (6.31)$$

Then  $Y$  satisfies (6.22), but now  $Y'(t)Y(t) = I$  and

$$A'_i + A_i = 0 \quad i = 0, 1, \dots, N \quad (6.32)$$

and

$$\hat{X}(t|t) = P^{-1/2}\hat{Y}(t|t)P^{1/2} \quad (6.33)$$

So the estimation problem for  $X$  is solved if we can solve the problem for  $Y$  evolving on  $SO(3)$ .

Similarly, if  $\mathbf{x}$  satisfies (6.27) and (6.30), we define

$$\mathbf{y}(t) = P^{1/2}\mathbf{x}(t) \quad (6.34)$$

Then  $\mathbf{y}$  satisfies (6.27) and (6.32), and

$$\mathbf{y}'(t)\mathbf{y}(t) = \mathbf{y}'(0)\mathbf{y}(0) \quad (6.35)$$

Thus  $\mathbf{y}$  evolves on  $S^n$  if  $||\mathbf{y}(0)|| = \mathbf{y}'(0)\mathbf{y}(0) = 1$ . The estimate  $\hat{\mathbf{x}}(t|t)$  can be computed according to

$$\hat{\mathbf{x}}(t|t) = P^{-1/2}\hat{\mathbf{y}}(t|t) \quad (6.36)$$

Because of the above analysis, we will limit our discussions in this chapter to systems evolving on  $SO(n)$  and  $S^n$ --i.e., we will assume that  $\{A_0, A_1, \dots, A_N\}$  satisfy (6.32) (they are skew-symmetric).

The underlying probability space for the estimation problem (6.22)-(6.23) on  $SO(n)$  is taken to be  $(\Omega, \mathcal{F}, P)$ , where  $\Omega$  is the space of continuous functions from  $[0, T]$  to  $SO(n)$ ,  $\mathcal{F}$  is the Borel  $\sigma$ -algebra for  $\Omega$ , and  $P$  is a measure on the space of continuous functions [D2], [W8]. The probability space for (6.27)-(6.28) on  $S^n$  is defined analogously.

The estimation criterion which we will use for these two systems is the constrained least-squares estimator of Chapter 4. As discussed in Section 4.2, the optimal estimate for the  $SO(n)$  system is

$$\tilde{X}(t|t) = \hat{X}(t|t) [\hat{X}(t|t)' \hat{X}(t|t)]^{-1/2} \quad (6.37)$$

The optimal estimate for the  $S^n$  system is given by (see Section 4.3)

$$\tilde{x}(t|t) = \frac{\hat{x}(t|t)}{\hat{x}(t|t)' \hat{x}(t|t)} = \frac{\hat{x}(t|t)}{\|\hat{x}(t|t)\|} \quad (6.38)$$

Thus in both cases we must compute the conditional expectation of the state ( $x(t)$  or  $X(t)$ ) given the observations  $z^t = \{z(s), 0 \leq s \leq t\}$ .

The equations for computing the conditional expectation can, as discussed in Chapter 2, be derived from the nonlinear filtering equation (1.7) and the moment equation (2.20). The resultant equations for the  $SO(n)$  system (6.22)-(6.23) are

$$\begin{aligned} dE^t[X_v^{[p]}(t)] &= [(A_0_{[p]} + \frac{1}{2} \sum_{i,j=1}^N Q_{ij}(t) A_{i[p]} A_{j[p]}) \otimes I] E^t[X_v^{[p]}(t)] dt \\ &+ \{E^t[X_v^{[p]}(t) h'(t) X(t)] - E^t[X_v^{[p]}(t)] h'(t) E^t[X(t)]\} R^{-1}(t) dv_1(t) \end{aligned} \quad (6.39)$$

$$dv_1(t) = dz_1(t) - \hat{X}(t|t)h(t)dt \quad (6.40)$$

where  $\otimes$  denotes Kronecker product and  $X_v^{[p]}$  is the vector containing the elements of the matrix  $X^{[p]}$  in lexicographic order [B8, p. 64], [M13, p. 9], [B13]. For the  $S^n$  system (6.27)-(6.28), we have

$$\begin{aligned} dE^t[x^{[p]}(t)] = & [A_{0[p]} + \frac{1}{2} \sum_{i,j=1}^N Q_{ij}(t)A_{i[p]}A_{j[p]}]E^t[x^{[p]}(t)]dt \\ & + \{E^t[x^{[p]}(t)x'(t)] - E^t[x^{[p]}(t)]E^t[x'(t)]\}H'(t)R^{-1}(t)dv_2(t) \end{aligned} \quad (6.41)$$

$$dv_2(t) = dz_2(t) - H(t)\hat{x}(t|t)dt \quad (6.42)$$

As illustrated in Figure 6.3, the structure of these equations is quite similar to that of (6.18)--i.e., each estimator consists of an infinite bank of filters, and the filter for the  $p^{\text{th}}$  moment is coupled only to those for the first and  $(p+1)^{\text{st}}$  moments. Therefore, we are led to the design of suboptimal estimators. Motivated by the success of Bucy and Willsky's phase tracking example evolving on  $S^1$ , we would like to design suboptimal estimators for the  $SO(n)$  and  $S^n$  systems using similar techniques.

We will require one further assumption in order to ensure the existence of the conditional density. Consider the deterministic systems associated with (6.27) and (6.22), as in Chapter 2:

$$\dot{x}(t) = [A_0 + \sum_{i=1}^N A_i u_i(t)]x(t) \quad (6.43)$$

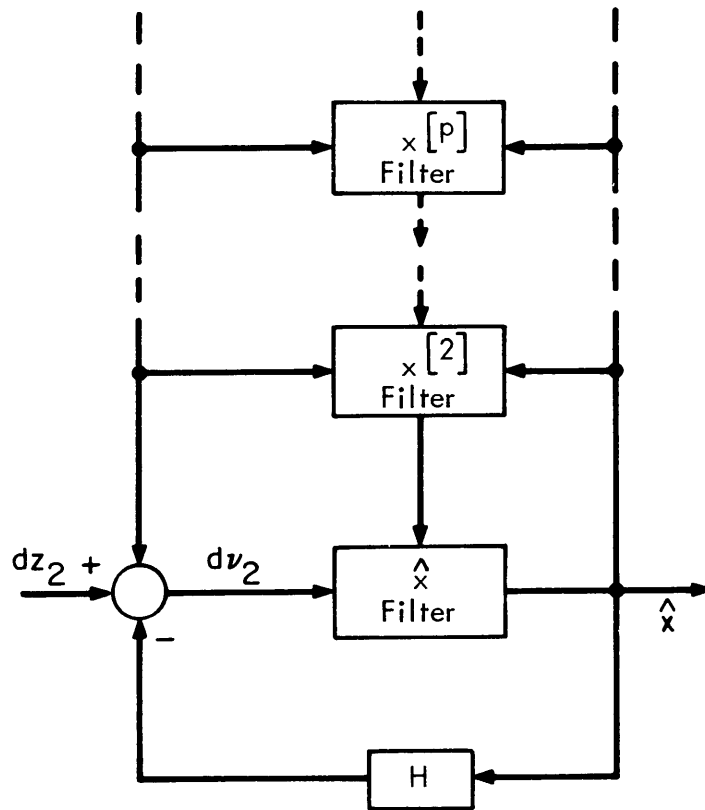

Figure 6.3 Illustrating the Form of the Infinite Dimensional Optimal Filter (6.41)-(6.42)

$$\dot{X}(t) = [A_0 + \sum_{i=1}^N A_i u_i(t)]X(t) \quad (6.44)$$

We call (6.43) controllable on  $S^n$  if for every pair of points  $x_0, x_1 \in S^n$  there exists  $t > 0$  and a piecewise continuous control  $u$  such that the solution  $\pi(x_0, u, t)$  of (6.43) with initial condition  $x_0$  satisfies  $\pi(x_0, u, t) = x_1$  [J3], [S6]. Controllability of (6.44) on  $SO(n)$  is defined analogously. It will be assumed in this chapter that (6.43) and (6.44) are controllable on  $S^n$  and  $SO(n)$ , respectively (Brockett [B4] discusses more explicit criteria for the controllability of these systems).

For systems defined on  $S^n$  or  $SO(n)$ , controllability implies the property of strong accessibility [S6]. Thus the results of Elliott [E3] show that, under the assumption of controllability, (6.22) and (6.27) have smooth transition probability densities (with respect to the Riemannian measure on  $S^n$  or the Haar measure on  $SO(n)$ --see Appendix B). It is easy to show from the definition of conditional expectation [W8] that, for each  $\omega \in \Omega$  and each  $t$ , the conditional probability measure  $P(\cdot | z^t)(\omega)$  is absolutely continuous with respect to the unconditional probability measure  $P(\cdot)$ . Hence the Radon-Nikodym Theorem [R2] implies the existence of the conditional probability densities  $p(x, t)$  of  $x(t)$  given  $z^t$ , with respect to the Riemannian measure on  $S^n$  or the Haar measure on  $SO(n)$ .

We now review the notions of Brownian motion and Gaussian densities on Lie groups and homogeneous spaces, which have received much attention in the literature (see K. Ito [I3], Grenander [G4], McKean [M7], [M8], Stein [S8], and Yosida [Y1]-[Y3]). Yosida [Y3]

proved that the density  $p(x, t)$  of a Brownian motion process on a Riemannian homogeneous space  $M$  with respect to the Riemannian measure (Haar measure if it is a Lie group) is the fundamental solution of

$$\frac{\partial p(x, t)}{\partial t} - G^* p(x, t) = 0 \quad (6.45)$$

where  $G^*$  is the formal adjoint of a differential operator expressible in local coordinates as

$$G = \sum_{i=1}^n f_i \frac{\partial}{\partial x_i} + \sum_{i,j=1}^n Q_{ij} \frac{\partial^2}{\partial x_i \partial x_j}$$

with constant  $f$  and  $Q = Q' \geq 0$ . In particular, if  $G$  is the Laplace-Beltrami operator (which is self-adjoint [H3]), the fundamental solution of

$$\frac{\partial p(x, t)}{\partial t} - \gamma \Delta p(x, t) = 0 \quad (6.46)$$

where  $\gamma > 0$ , is a Brownian motion on  $M$ . According to [M13] and [S8], the fundamental solution of (6.46) is given by

$$p(x, t; x_0, t_0) = \sum_i \phi_i(x) \phi_i(x_0) e^{-\lambda_i (t-t_0) \gamma}$$

where  $\lambda_i$  and  $\phi_i$  are the eigenvalues and the corresponding eigenfunctions of the Laplace-Beltrami operator (see Section B4). The function  $p(x, t; x_0, t_0)$  is the solution to (6.46) with initial condition equal to the singular distribution concentrated at  $x = x_0$ . Also, Grenander [G4] defines a Gaussian (normal) density to be the solution of (6.45) for some  $t$ .

The folded normal density  $F(\theta; \eta, \gamma)$  used by Willsky as an assumed density approximation for the phase tracking problem is indeed a normal

density on  $S^1$  in the sense of Grenander [W2]. Motivated by the success of Willsky's suboptimal filter, we will design suboptimal estimators for the  $S^0(n)$  and  $S^n$  bilinear systems by employing normal assumed conditional densities of the form

$$p(x, t) = \sum_i \phi_i(x) \phi_i(\eta(t)) e^{-\lambda_i \gamma(t)} \quad (6.47)$$

where  $\eta(t)$  and  $\gamma(t)$  are parameters of the density which are to be estimated.

#### 6.4 Estimation on $S^n$

In this section we will use the suboptimal estimation technique discussed in the previous section in order to design filters for the  $S^n$  estimation problem (6.27)-(6.28). The optimal constrained least-squares estimator is described by (6.38) and (6.41)-(6.42). We will first describe the suboptimal estimator in detail for  $S^2$ ; then we will discuss the generalization to  $S^n$ . The  $S^2$  problem is also of importance because the satellite tracking problem of Section 4.4 is of this form (notice that equation (4.35) has a time-varying drift term; however, this can be easily handled in the present framework).

In our discussion of estimation on  $S^2$ , we will refer to a point on  $S^2$  in terms of the Cartesian coordinates  $x \stackrel{\Delta}{=} (x_1, x_2, x_3)$  or the polar coordinates  $(\theta, \phi)$  (see (B.42)). The decomposition (B.41) of homogeneous polynomials of degree  $n$  (restricted to  $S^2$ ) in terms of the spherical harmonics of degree  $\leq n$  implies the existence of a nonsingular matrix  $P$  such that



$$P_X^{[n]} = \begin{bmatrix} Y_n(x) \\ Y_{n-2}(x) \\ \vdots \\ Y_\delta(x) \end{bmatrix} \quad (6.48)$$

where  $Y_\ell(x)$  is the  $(2\ell + 1)$ -vector whose components are the spherical harmonics  $\{Y_{\ell m}, -\ell \leq m \leq \ell\}$  of degree  $\ell$  (defined in (B.46)-(B.47)) and  $\delta$  is zero or one depending on whether  $n$  is even or odd. Here the spaces spanned by  $Y_\ell(x)$ ,  $\ell = \delta, \delta + 2, \dots, n-2, n$  are all invariant under the action of  $SO(3)$  (this decomposition is related to the classical notions of contractions and traceless tensors [H5]; see also Brockett [B3]). Hence the conditional moments  $E^t[x^{[P]}(t)]$ , and consequently the optimal estimator (6.41), could have been expressed in terms of the "generalized Fourier coefficients"

$$\begin{aligned} c_{\ell m}(t) &= \int_0^{2\pi} \int_0^\pi Y_{\ell m}^*(\theta(t), \phi(t)) p(\theta, \phi, t) \sin\theta \, d\theta d\phi \\ &= E^t[Y_{\ell m}^*(\theta(t), \phi(t))] \end{aligned} \quad (6.49)$$

Referring to Section B.5, we note that  $Y_{\ell m}$  is an eigenfunction of the Laplace-Beltrami operator  $\Delta_{S^2}$  (defined in (B.45)) with eigenvalue  $-\ell(\ell + 1)$ . Thus the assumed density approximation is a normal density on  $S^2$  of the form (6.47), as discussed in the previous section:

$$p(\theta, \phi, t) = \sum_{\ell=0}^{\infty} \sum_{m=-\ell}^{\ell} Y_{\ell m}(\theta, \phi) Y_{\ell m}^*(\eta(t), \lambda(t)) e^{-\ell(\ell+1)\gamma(t)} \quad (6.50)$$

In other words,  $c_{\ell m}(t)$  (as defined in (6.49)) is assumed to be

$$c_{\ell m}(t) = Y_{\ell m}^*(\eta(t), \lambda(t)) e^{-\ell(\ell+1)\gamma(t)} \quad (6.51)$$

In order to truncate the optimal estimator after the  $\hat{x}^{[N]}(t|t)$  equation using the assumed density (6.50), we must compute  $E^t[x^{[N]}(t)x'(t)]$ , or equivalently,  $\hat{x}^{[N+1]}(t|t)$ , in terms of  $\hat{x}^{[p]}(t|t)$ ,  $p = 1, 2, \dots, N$ . However, if  $\hat{x}(t|t)$  is known, so are  $c_{10}(t)$  and  $c_{11}(t)$ , and a simple computation yields

$$\gamma(t) = -\log \left[ \frac{4\pi}{3} \left( c_{10}^2(t) + 2|c_{11}(t)|^2 \right) \right] \quad (6.52)$$

$$\cos \eta(t) = \frac{c_{10}(t)}{[c_{10}^2(t) + 2|c_{11}(t)|^2]^{1/2}} \quad (6.53)$$

$$\sin \eta(t) = \frac{\pm \sqrt{2} |c_{11}(t)|}{[c_{10}^2(t) + 2|c_{11}(t)|^2]^{1/2}} \quad (6.54)$$

If  $c_{11}(t) = 0$ , then the density is independent of  $\lambda(t)$ ; otherwise,

$$e^{2i\lambda(t)} = \frac{c_{11}^*(t)}{c_{11}(t)} \quad (6.55)$$

Then  $\{c_{N+1,m}, m = -(N+1), \dots, N+1\}$  can be computed from

$$\begin{aligned} c_{N+1,m}(t) &= Y_{N+1,m}^*(\eta(t), \lambda(t)) e^{-(N+1)(N+2)\gamma(t)} \\ &= (-1)^m \left[ \frac{(N+1-m)!}{(N+1+m)!} \frac{2N+3}{4\pi} \right]^{1/2} P_{N+1,m} \left( \frac{c_{10}(t)}{[c_{10}^2(t) + 2|c_{11}(t)|^2]^{1/2}} \right) \\ &\quad \cdot \left( \frac{c_{11}^*(t)}{c_{11}(t)} \right)^{m/2} \left[ \frac{4\pi}{3} \left( c_{10}^2(t) + 2|c_{11}(t)|^2 \right) \right]^{\frac{1}{4} (N+1)(N+2)} \end{aligned} \quad (6.56)$$

Finally, notice that (B.41) and (6.48) imply the existence of a non-singular matrix P such that

$$P_{\mathbf{x}}^{[N+1]} = \begin{bmatrix} Y_{N+1}(\mathbf{x}) \\ \mathbf{x}^{[N-1]} \end{bmatrix}$$

where  $Y_{\ell}$  is the  $(2\ell+1)$ -vector with components  $\{Y_{\ell m}, -\ell \leq m \leq \ell\}$ . Thus  $\hat{\mathbf{x}}^{[N+1]}(t|t)$  can be computed from  $\{c_{N+1,m}, -(N+1) \leq m \leq N+1\}$  and  $\hat{\mathbf{x}}^{[N-1]}(t|t)$ . The optimal estimator (6.41) is truncated by substituting this approximation for  $\hat{\mathbf{x}}^{[N+1]}(t|t)$  into the equation for  $\hat{\mathbf{x}}^{[N]}(t|t)$ .

Notice that the entire procedure for truncating the optimal estimator can equivalently be performed on the infinite set of coupled equations for the generalized Fourier coefficients  $c_{\ell m}(t)$ , using the approximation (6.51).

We note that one can show that

$$\sqrt{||\hat{\mathbf{x}}(t|t)||} \leq 1$$

and (see (6.14)-(6.15)) this quantity can be used as a measure of our confidence in our estimate. If  $\hat{\mathbf{x}}(t|t)$  satisfies the assumed density (6.50),

$$||\hat{\mathbf{x}}(t|t)|| = e^{-\gamma(t)} \tag{6.57}$$

and we can perform a similar analysis to that in the  $S^1$  case (see (6.15)).

Example 6.1: Suppose that we truncate the optimal  $S^2$  estimator (6.41) after  $N = 1$ --i.e., we approximate  $\hat{\mathbf{x}}^{[2]}(t|t)$  using the above approximation. The resulting suboptimal estimator is (for  $Q(t) = I$ )

$$d\hat{x}(t|t) = [A_0 + \frac{1}{2} \sum_{i=1}^N A_i^2] \hat{x}(t|t) dt + P(t)H'(t)R^{-1}(t)[dz_2(t) - H(t)\hat{x}(t|t)dt] \quad (6.58)$$

where the covariance matrix  $P(t)$  is given by

$$P_{ii}(t) = \hat{x}_i^2(t|t) \left( \frac{2}{3} ||\hat{x}(t|t)|| - 1 \right) - \frac{1}{3} (\hat{x}_j^2(t|t) + \hat{x}_k^2(t|t)) ||\hat{x}(t|t)|| + \frac{1}{3} \quad (6.59)$$

for  $i \neq j$ ,  $i \neq k$ ,  $j \neq k$ , and

$$P_{ij}(t) = \hat{x}_i(t|t)\hat{x}_j(t|t) (||\hat{x}(t|t)|| - 1) \quad (6.60)$$

for  $i \neq j$ . Notice that, from (6.57),  $||\hat{x}(t|t)|| = 1$  implies that the "variance"  $\gamma(t) = 0$ ; in fact, if  $||\hat{x}(t|t)|| = 1$ , we see from (6.59)-(6.60) that the covariance matrix  $P(t)$  is identically zero. Thus if  $||\hat{x}(t|t)|| = 1$ , this first order suboptimal filter assumes that it has perfect knowledge of  $x(t)$  and disregards the measurements.

The extension to  $S^n$  of this technique for constructing suboptimal estimators is straightforward. The procedure uses the spherical harmonics on  $S^n$ , as defined in Section B.5. In polar coordinates, a point on  $S^n$  can be described by  $(\theta_1, \theta_2, \dots, \theta_{n-1}, \phi) \triangleq (\theta, \phi)$ , where  $0 \leq \theta_j \leq \pi$  and  $0 \leq \phi \leq 2\pi$ . Also, the spherical harmonics are denoted by

$$Y_{\ell, (m)}(\theta, \phi) \triangleq Y_{\ell, m_1, \dots, m_{n-1}}(\theta_1, \dots, \theta_{n-1}, \pm \phi) = e^{\frac{\pm im_{n-1}\phi}{n-1}} \prod_{k=0}^{n-2} (\sin \theta_{k+1})^{m_{k+1}} C_{m_k - m_{k+1}}^{m_{k+1} + \frac{1}{2}(n-k-1)}(\cos \theta_{k+1}) \quad (6.61)$$

where  $\ell \geq m_1 \geq \dots \geq m_{n-1} \geq 0$  and  $C_j^i$  are the Gegenbauer polynomials [E1] (that is, the functions  $Y_{\ell, (m)}$  satisfy the four properties of Section B.5). Since  $Y_{\ell, (m)}$  is an eigenfunction of the Laplace-Beltrami operator with eigenvalue  $-\ell(\ell+n-1)$ , the assumed density approximation on  $S^n$  is

$$p(\theta, \phi, t) = \sum_{\ell, (m)} Y_{\ell, (m)}(\theta, \phi) Y_{\ell, (m)}^*(\eta(t), \lambda(t)) e^{-\ell(\ell+n-1)\gamma(t)} \quad (6.62)$$

That is,  $c_{\ell, (m)}(t) \triangleq E^t[Y_{\ell, (m)}^*(\theta(t), \phi(t))]$  is assumed to be

$$c_{\ell, (m)}(t) = Y_{\ell, (m)}^*(\eta(t), \lambda(t)) e^{-\ell(\ell+n-1)\gamma(t)} \quad (6.63)$$

The procedure for truncating the filter (6.41) is identical to the  $S^2$  case. If  $\hat{x}(t|t)$  is known, so are  $c_{1, (m)}(t)$ , and these can be used to compute  $\gamma(t)$ ,  $\eta(t)$ , and  $\lambda(t)$ . Then  $\{c_{N+1, (m)}(t)\}$  can be computed from (6.63), and  $\hat{x}^{[N+1]}(t|t)$  can be computed from  $\{c_{N+1, (m)}(t)\}$  and  $\hat{x}^{[N-1]}(t|t)$ . The estimator is truncated by substituting this approximate expression for  $\hat{x}^{[N+1]}(t|t)$  into the equation (6.41) for  $\hat{x}^{[N]}(t|t)$ .

## 6.5 Estimation on $SO(n)$

In this section we discuss the construction of suboptimal estimators for the  $SO(n)$  estimation problem (6.22)-(6.23). Since  $SO(2)$  is isomorphic to the circle  $S^1$ , the case  $n=2$  was discussed in Section 6.2. We will first consider the  $SO(3)$  problem, the importance of which was discussed in Chapter 4. Then we will extend the results to  $SO(n)$ .

Consider the sequence  $\{D^\ell, \ell = 0, 1, \dots\}$  of irreducible unitary representations of  $SO(3)$ , as defined in (B.34)-(B.35). Theorem B.7

implies that, for fixed  $\ell$ , the matrix elements  $\{D_{mn}^\ell; -\ell \leq m, n \leq \ell\}$  are eigenfunctions of the bi-invariant Laplacian  $\Delta_{SO(3)}$  defined in (B.33) with the same eigenvalue  $\lambda_\ell$ ; also, all eigenfunctions of the Laplacian can be written as linear combination of the  $\{D_{mn}^\ell\}$ . Hence, the assumed density which will be used to truncate the optimal estimator (6.39)-(6.40) is a normal density on  $SO(3)$  of the form (6.47):

$$p(R, t) = \sum_{\ell=0}^{\infty} \sum_{m, n=-\ell}^{\ell} D_{mn}^\ell(R) D_{mn}^\ell(\eta(t))^* e^{-\lambda_\ell \gamma(t)} \quad (6.64)$$

where  $R, \eta(t) \in SO(3)$  and  $\gamma(t)$  is a scalar. That is,

$$c_{mn}^\ell(t) \triangleq E^t [D_{mn}^\ell(\eta(t))^*] \quad (6.65)$$

is assumed to be

$$c_{mn}^\ell(t) = D_{mn}^\ell(\eta(t))^* e^{-\lambda_\ell \gamma(t)} \quad (6.66)$$

The procedure for truncating the filter (6.39) is similar to the  $S^n$  case, although we make use of some additional concepts from representation theory. If  $\hat{X}(t|t)$  is known, so are  $\{c_{mn}^1(t); -1 \leq m, n \leq 1\}$ , since  $D^1$  is equivalent to the self-representation of  $SO(3)$ . Define the matrix  $C^\ell(t)$  with elements  $c_{mn}^\ell(t)$ ,  $-\ell \leq m, n \leq \ell$ ; then

$$\begin{aligned} A(t) &\triangleq \bar{C}^1(t) C^1(t) = [D^1(\eta(t))]' [D^1(\eta(t))]^* e^{-2\lambda_1 \gamma(t)} \\ &= I \cdot e^{-2\lambda_1 \gamma(t)} \end{aligned} \quad (6.67)$$

since  $D^1$  is unitary (here  $\bar{C}$  is the hermitian transpose of  $C$ ). Thus  $\gamma(t)$  can be computed from

$$\gamma(t) = -\frac{1}{2\lambda_1} \log\left[\frac{1}{3} \text{tr } A(t)\right] \quad (6.68)$$

Then the elements of  $\eta(t)$  can be computed from (6.66) and (6.68), since  $D^1(\eta(t))$  is similar to  $\eta(t)$ . Once  $\gamma(t)$  and  $\eta(t)$  have been computed,  $\{c_{mn}^{N+1}; -(N+1) \leq m, n \leq N+1\}$  are computed from the formula (6.63).

In order to truncate (6.39) after the  $N^{\text{th}}$  moment equation, we must approximate  $E^t[X_v^{[N]}(t)h'(t)X(t)]$ ; however, this matrix consists of time-varying deterministic functions multiplying elements of  $\hat{X}^{[N+1]}(t|t)$ , so we will show how to approximate this matrix. The symmetrized Kronecker  $p^{\text{th}}$  power  $X^{[p]}$  operating on the symmetric tensors  $x^{[p]}$  such that  $||x^{[p]}|| = ||x||^p = 1$  furnishes a representation of  $SO(3)$  which is reducible [H5], [M16]. In fact, (B.41) and (6.48) imply that there is a nonsingular matrix  $P$  such that

$$P X^{[p]} P^{-1} = \begin{bmatrix} D^p(X) & 0 \\ 0 & X^{[p-2]} \end{bmatrix} \quad (6.69)$$

The matrix  $P$  is related to the Clebsch-Gordan coefficients (B.38)-(B.39), but  $P$  can also be computed by the method of Gantmacher [G7, p. 160]. It is clear from the decomposition (6.69) that  $\hat{X}^{[N+1]}(t|t)$  can be computed from  $C^{N+1}(t)$  and  $\hat{X}^{[N-1]}(t|t)$ . The optimal estimator (6.39) is truncated by substituting this approximation into the equation for  $\hat{X}^{[N]}(t|t)$ .

We note here that, due to the decomposition (6.69), the estimation equations and the truncation procedure could have been expressed solely in terms of the irreducible representations  $D^p(X(t))$ . However, we have chosen to work with the  $X^{[p]}$  equations primarily for ease of notation. For large  $N$ , the  $D^p$  equations would provide significant computational savings over the  $X^{[p]}$  equations, as these are redundant; however, the

practical implementation of this technique will probably be limited to small values of  $N$ .

As in the previous section, the extension of this technique to  $SO(n)$  is straightforward. In this case, we make use of the irreducible representations of  $SO(n)$  denoted by  $D^{[f_1, \dots, f_k]} \triangleq D^{[f]}$ , where  $n = 2k$  or  $n = 2k+1$  and  $[f] = [f_1, \dots, f_k]$  denotes a Young pattern (see Section B.5). Theorem B.7 implies that, for fixed  $[f]$ , the matrix elements  $\{D_{\ell m}^{[f]}, 1 \leq \ell, m \leq n_{N_{[f]}}\}$  are eigenfunctions of the bi-invariant Laplacian on  $SO(n)$  with the same eigenvalue  $\lambda_{[f]}$ . Thus the assumed density is a normal density on  $SO(n)$  of the form

$$p(R, t) = \sum_{[f]} \sum_{\ell, m} D_{\ell m}^{[f]}(R) D_{\ell m}^{[f]}(\eta(t)) * e^{-\lambda_{[f]} \gamma(t)} \quad (6.70)$$

where  $R, \eta(t) \in SO(n)$  and  $\gamma(t)$  is a scalar. That is,

$$c_{\ell m}^{[f]}(t) = E^t [D_{\ell m}^{[f]}(\eta(t)) *] \quad (6.71)$$

is assumed to be

$$c_{\ell m}^{[f]}(t) = D_{\ell m}^{[f]}(\eta(t)) * e^{-\lambda_{[f]} \gamma(t)} \quad (6.72)$$

If  $\hat{X}(t|t)$  is known, so are  $\{c_{\ell m}^{[1, 0, \dots, 0]}(t); 1 \leq \ell, m \leq n\}$ , since  $D^{[1, 0, \dots, 0]}$  is just the self-representation of  $SO(n)$  (see Section B.5). If we define the matrix  $C^1(t)$  with elements  $\{c_{\ell m}^{[1, 0, \dots, 0]}(t); 1 \leq \ell, m, \leq n\}$ , then

$$\begin{aligned} A(t) &\triangleq [C^1(t)]' [C^1(t)] = \eta'(t) \eta(t) e^{-2\lambda_1 \gamma(t)} \\ &= I \cdot e^{-2\lambda_1 \gamma(t)} \end{aligned} \quad (6.73)$$



and  $\gamma(t)$  can be computed from

$$\gamma(t) = -\frac{1}{2\lambda_1} \log\left[\frac{1}{n} \text{tr } A(t)\right] \quad (6.74)$$

Then the elements of  $\eta(t)$  can be computed from (6.72) and (6.74).

In order to truncate the optimal estimator (6.39) after the  $N^{\text{th}}$  moment equation, we approximate  $\hat{X}^{[N+1]}(t|t)$  as before. Since the carrier space of the representation  $D^{[p,0,\dots,0]}$  is spanned by the spherical harmonics of degree  $p$ , the decomposition (B.41) implies that there exists a nonsingular matrix  $P$  such that

$$P_X^{[p]} P^{-1} = \begin{bmatrix} D^{[p,0,\dots,0]}(X) & 0 \\ 0 & X^{[p-2]} \end{bmatrix} \quad (6.75)$$

(see Section B.5).

Hence, precisely as in the  $SO(3)$  case, we compute

$$C^{N+1}(t) \triangleq \{c_{\ell m}^{[N+1,0,\dots,0]}(t); 1 \leq \ell, m \leq n_{N+1,0,\dots,0}\} \text{ from (6.72)}$$

and then compute  $\hat{X}^{[N+1]}(t|t)$  from  $C^{N+1}(t)$  and  $\hat{X}^{[N-1]}(t|t)$ . The optimal estimator (6.39) is truncated by substituting this approximation into the equation for  $\hat{X}^{[N]}(t|t)$ .

## CHAPTER 7

### CONCLUSION AND SUGGESTIONS FOR FUTURE RESEARCH

This thesis has been concerned with estimation and stability for nonlinear stochastic systems. The basic approach has been the explicit utilization of the algebraic and geometric structure of certain classes of systems. With this approach, it was possible to derive some interesting conditions for stochastic stability and to design both optimal and sub-optimal estimators. A detailed summary of the major results is given below.

#### 7.1 Summary of Results

First, the stability of bilinear systems driven by colored noise was considered. Necessary and sufficient conditions for the  $p^{\text{th}}$  order stability of bilinear systems evolving on solvable Lie groups were derived, and several examples were presented. Some approximate methods for deriving stability criteria for general bilinear systems driven by colored noise were discussed, but no definitive results were obtained.

In order to motivate the discussion of estimation problems and to demonstrate the applicability of stochastic bilinear models, several practical estimation problems were formulated. These problems involved the estimation of three-dimensional rotational processes and the tracking of orbiting satellites.

The investigation of estimation problems involved both optimal and suboptimal estimation. It was first shown that the optimal conditional mean estimator for certain classes of systems is finite dimensional. These classes of systems are characterized by linear measurements of a

Gauss-Markov process  $\xi$ ;  $\xi$  then feeds forward into a nonlinear system.

For some nonlinear systems, including those with a finite Volterra series and certain bilinear systems, it was proved that the optimal estimator is finite dimensional. However, for general nonlinear systems the optimal estimator is infinite dimensional, and a suboptimal estimation technique was presented.

Finally, suboptimal estimation for bilinear systems driven by white noise was discussed. The theory of harmonic analysis was used to design suboptimal estimators for bilinear systems evolving on compact Lie groups and homogeneous spaces. The basic approach involved the assumption of an assumed density, which was the solution of the heat equation on the appropriate manifold.

## 7.2 Suggestions for Future Research

In this section, several topics for future research which are suggested by the work in this thesis are presented.

- 1) The problem of deriving explicit necessary and sufficient conditions in terms of  $A_0, A_1, \dots, A_N$  for the  $p^{\text{th}}$  order (asymptotic) stability of the bilinear system (2.12) driven by white noise. For example, the derivation of necessary and sufficient conditions under which (2.12) is  $p^{\text{th}}$  order stable for all  $p$  is an open problem.
- 2) The development of a procedure for bounding the solution of a general bilinear system by the solution of one in which  $\mathcal{L}$  is solvable. This will lead to better conditions for the stability of bilinear systems driven by colored noise.

- 3) The extension of the bilinearization and Volterra series techniques to nonlinear systems driven by white noise (see [K4], [L5]). This may permit the application of bilinear stochastic stability results and the suboptimal estimation techniques of Chapter 6 to more general nonlinear systems.
- 4) The evaluation of the suboptimal filters of Chapter 6 by means of computer simulations. This is presently being done for the first-order filter of Example 6.1 and the corresponding second-order filter, for the system (6.27)-(6.28) evolving on  $S^2$ ; these filters are being compared with the extended Kalman filter [J1], the Gaussian second-order filter [J1], and the Gustafson-Speyer "state-dependent noise filter" [G2]. Unfortunately, these simulations have not been completed in time for presentation in this thesis.
- 5) The use of harmonic analysis in estimation for bilinear systems driven by colored noise.
- 6) The application of the various techniques of this thesis to both deterministic and stochastic control problems. For example, a procedure analogous to the one developed in Chapter 6 may provide useful suboptimal controllers for certain problems.

## APPENDIX A

### A SUMMARY OF RELEVANT RESULTS FROM ALGEBRA AND DIFFERENTIAL GEOMETRY

#### A.1 Introduction

In this appendix we summarize the results from the fields of differential geometry, Lie groups, and Lie algebras which are relevant to the research in this thesis. Proofs and more extensive treatments of these subjects may be found in [A2], [B20], [C3], [G5], [H3], [J4], [S1], [S2], [W11].

#### A.2 Lie Groups and Lie Algebras

The study of general Lie groups and Lie algebras requires concepts from the theory of differentiable manifolds. However, the research in this thesis is primarily concerned with matrix Lie groups and Lie algebras, and our basic definitions will follow the work of Brockett [B1] and Willsky [W2].

Let  $R^{n \times n}$  be the  $n^2$ -dimensional vector space of  $n \times n$  matrices with real-valued entries.

Definition A.1: An  $n \times n$  matrix Lie Algebra  $\mathcal{L}$  is a subspace of  $R^{n \times n}$  which has the property that if  $A$  and  $B$  are in  $\mathcal{L}$ , then so is their commutator product,  $[A, B] \triangleq AB - BA$ .

We note that the intersection of two Lie algebras is also a Lie algebra, but the union, sum, and commutator of two Lie algebras are not necessarily Lie algebras.

Definition A.2: Let  $S$  be a subset of  $R^{n \times n}$ . The Lie algebra generated by  $S$ , denoted  $\{S\}_{LA}$ , is the smallest Lie algebra which contains  $S$ .

Definition A.3: A Lie subalgebra of a Lie algebra  $\mathcal{L}$  is a subspace of  $\mathcal{L}$  that is also a Lie algebra. A Lie subalgebra  $\mathcal{I}$  is an ideal of  $\mathcal{L}$  if  $[A, B] \in \mathcal{I}$  whenever  $A \in \mathcal{L}$  and  $B \in \mathcal{I}$ .

Definition A.4: Let  $T$  be a set of nonsingular matrices in  $R^{n \times n}$ . The matrix group generated by  $T$ , denoted  $\{T\}_G$ , is the smallest group under matrix multiplication which contains  $T$ . If  $S$  is a subspace of  $R^{n \times n}$ , we define the matrix group

$$T = \{\exp S\}_G = \{e^{A_1} e^{A_2} \dots e^{A_p} \mid A_i \in S, p=0,1,2,\dots\} \quad (A.1)$$

A matrix group  $G$  is called a matrix Lie group if there exists a matrix Lie algebra  $\mathcal{L}$  such that

$$G = \{\exp \mathcal{L}\}_G$$

There is then a Lie algebra isomorphism between  $\mathcal{L}$  and the tangent space of  $G$  at the identity  $[S_1]$ . It has been shown by Brockett [B1] that if  $S_1, \dots, S_p$  is a collection of subspaces of  $R^{n \times n}$ , then

$$\{\exp S_1, \dots, \exp S_p\}_G = \{\exp\{S_1, \dots, S_p\}_{LA}\}_G \quad (A.2)$$

The relationship between these concepts and the theory of differentiable manifolds can be explained as follows [B1]. Let  $\mathcal{L}$  be a Lie algebra. At each point  $T$  in  $\{\exp \mathcal{L}\}_G$  there is a one-to-one mapping  $\phi_T$  from a neighborhood of 0 in  $\mathcal{L}$  onto a neighborhood of  $T$  in  $\{\exp \mathcal{L}\}_G$  which is defined by

$$\phi_T: \mathcal{L} \rightarrow \{\exp \mathcal{L}\}_G, \phi_T(L) = e^L T \quad (A.3)$$

Since this map has a smooth inverse,  $\{\exp \mathcal{L}\}_G$  is a locally Euclidean space of dimension equal to the dimension of  $L$ . In addition, the set

of maps  $\{\phi_T^{-1}\}$  form a differentiable structure of class  $C^\infty$  on  $\{\exp \mathcal{L}\}_G$  [W11]. Thus  $\{\exp \mathcal{L}\}_G$  has the structure of a differentiable manifold [W11].

The analysis of systems defined on manifolds which do not have a Lie group structure leads to the following definitions.

Definition A.5: Let  $M \subset R^n$  be a manifold, and let  $G$  be a matrix Lie group in  $R^{n \times n}$ . We say that  $G$  acts on  $M$  if for every  $x \in M$  and every  $T \in G$ ,  $Tx$  belongs to  $M$ ; in this case,  $G$  is called a Lie transformation group. The group  $G$  acts transitively on  $M$  if it acts on  $M$  and if for every pair of points  $x, y$  in  $M$ , there exists  $T \in G$  such that  $Tx = y$ . If  $x \in M$  is fixed, then  $H_x = \{T \in G | Tx = x\}$  is a subgroup of  $G$  called the isotropy group at  $x$ .

Definition A.6: Let  $G$  be a Lie group which acts transitively on a manifold  $M$ . Let  $x$  be some (fixed) point in  $M$ . Let  $G/H_x$  be the set  $\{TH_x | T \in G\}$  of left cosets modulo  $H_x$ . Then there is a diffeomorphism between  $G/H_x$  and  $M$ , and  $M$  is called a homogeneous space (coset space) [W11].

### A.3 Solvable, Nilpotent, and Abelian Groups and Algebras

The definitions and properties of some important classes of Lie algebras and Lie groups are presented in this and the next section.

Definition A.7 [S1]: A Lie algebra  $\mathcal{L}$  is solvable if the derived series of ideals

$$\begin{aligned} \mathcal{L}^{(0)} &= \mathcal{L} \\ \mathcal{L}^{(n+1)} &= [\mathcal{L}^{(n)}, \mathcal{L}^{(n)}] = \{[A, B] | A, B \in \mathcal{L}^{(n)}\}, \quad n \geq 0 \end{aligned} \quad (A.4)$$

terminates in  $\{0\}$ .  $\mathcal{L}$  is nilpotent if the lower central series of ideals

$$\mathcal{L}^0 = \mathcal{L}$$

$$\mathcal{L}^{n+1} = [\mathcal{L}, \mathcal{L}^n] = \{[A, B] \mid A \in \mathcal{L}, B \in \mathcal{L}^n\}, n \geq 0 \quad (\text{A.5})$$

terminates in  $\{0\}$ .  $\mathcal{L}$  is abelian if  $\mathcal{L}^{(1)} = \mathcal{L}^1 = \{0\}$ . Note that abelian  $\Rightarrow$  nilpotent  $\Rightarrow$  solvable, but none of the reverse implications hold in general.

Lemma A.1 [Sl, p. 214]: A matrix Lie algebra  $\mathcal{L}$  is solvable if and only if there exists a (possibly complex-valued) nonsingular matrix  $P$  such that  $PAP^{-1}$  is in upper triangular form (zero below diagonal) for all  $A \in \mathcal{L}$ .

Lemma A.2 [Sl, p. 224]: A matrix Lie algebra  $\mathcal{L}$  is nilpotent if and only if there exists a (possibly complex-valued) nonsingular matrix  $P$  such that, for all  $A \in \mathcal{L}$ ,  $PAP^{-1}$  has the block diagonal form

$$\left[ \begin{array}{ccc} \left[ \begin{array}{ccc} \phi_1(A) & & * \\ & \cdot & \\ 0 & & \cdot \\ & & \phi_1(A) \end{array} \right] & & 0 \\ & \left[ \begin{array}{ccc} \phi_2(A) & & * \\ & \cdot & \\ & & \cdot \\ & & \phi_2(A) \end{array} \right] & & 0 \\ & & & & \cdot \\ & & & & \cdot \\ & & & & \cdot \\ & & & & \cdot \\ & & & & \cdot \end{array} \right] \quad (\text{A.6})$$

(this will be called the nilpotent canonical form). The functions  $\phi_k: \mathcal{L} \rightarrow \mathcal{C}$  are linear. Furthermore,  $\phi_k([\mathcal{L}, \mathcal{L}]) = \{0\}$ .



A useful criterion for solvability can be expressed in terms of the Killing form.

Definition A.8: Let  $\mathcal{L}$  be a matrix Lie algebra. If  $A, B \in \mathcal{L}$ , the operators  $\text{ad}_A^i: \mathcal{L} \rightarrow \mathcal{L}$  are defined by  $\text{ad}_A^0 B = B$ ,  $\text{ad}_A^1 B = \text{ad}_A^1 B = [A, B]$ ,  $\text{ad}_A^{i+1} B = [A, \text{ad}_A^i B]$ . If  $\mathcal{B}$  is a Lie subalgebra of  $\mathcal{L}$ , we define  $\text{ad}_A^i \mathcal{B} = \{\text{ad}_A^i B \mid B \in \mathcal{B}\}$ . The Killing form of  $\mathcal{L}$  is a symmetric bilinear form on  $\mathcal{L}$  given by

$$K(A, B) = \text{trace}(\text{ad}_A \circ \text{ad}_B) \quad (\text{A.7})$$

Theorem A.1 (Cartan's criterion for solvability)[S2]: A Lie algebra  $\mathcal{L}$  is solvable if and only if  $K(A, B) = 0$  for all  $A$  and  $B$  in the derived algebra  $\mathcal{L}^{(1)}$ .

We define the corresponding Lie groups as follows.

Definition A.9: The matrix Lie group  $G = \{\exp \mathcal{L}\}_G$  is solvable if  $\mathcal{L}$  is solvable;  $G$  is nilpotent if  $\mathcal{L}$  is nilpotent;  $G$  is abelian if  $\mathcal{L}$  is abelian.

We note that Definition A.8 is equivalent to the usual definition expressed strictly in terms of properties of the group  $G$ [S1].

#### A.4 Simple and Semisimple Groups and Algebras

It can easily be shown [S2] that the sum of two solvable (nilpotent) ideals of a Lie algebra  $\mathcal{L}$  is solvable (nilpotent). Hence we make the following definitions [S1], [S2].

Definition A.10: Let  $\mathcal{L}$  be a Lie algebra. The radical  $\mathcal{R}$  of  $\mathcal{L}$  is the unique maximal solvable ideal of  $\mathcal{L}$  (i.e.,  $\mathcal{R}$  is the sum of the solvable ideals of  $\mathcal{L}$ ).

Definition A.11: A Lie algebra  $\mathcal{L}$  is semisimple if it has no abelian ideals other than  $\{0\}$ . Thus  $\mathcal{L}$  is semisimple if and only if its radical  $\mathcal{R} = \{0\}$ .  $\mathcal{L}$  is simple if it is non-abelian and has no ideals other than  $\{0\}$  or  $\mathcal{L}$ .

The Killing form can also be used to formulate a criterion for semisimplicity.

Theorem A.2 (Cartan's criterion for semisimplicity) [S2]:

A Lie algebra  $\mathcal{L}$  is semisimple if and only if its Killing form is non-degenerate (i.e., if  $A \in \mathcal{L}$  and  $K(A,B) = 0$  for all  $B \in \mathcal{L}$ , then  $A = 0$ ).

Combining the Levi decomposition of an arbitrary Lie algebra and the complete reducibility of a semisimple Lie algebra, we have the following theorem [G5].

Theorem A.3: An arbitrary nonsemisimple Lie algebra  $\mathcal{L}$  has a semi-direct sum structure

$$\begin{aligned} \mathcal{L} &= \mathcal{R} + \mathcal{I} \\ [\mathcal{I}, \mathcal{R}] &\subset \mathcal{R} \end{aligned} \tag{A.8}$$

where  $\mathcal{R}$  is the radical of  $\mathcal{L}$  and  $\mathcal{I}$  is a semisimple subalgebra. Furthermore,  $\mathcal{I}$  can be written as the direct sum of simple subalgebras

$$\begin{aligned} \mathcal{I} &= \mathcal{I}_1 + \mathcal{I}_2 + \mathcal{I}_3 + \dots \\ [\mathcal{I}_i, \mathcal{I}_j] &= \{0\}, \quad i \neq j \end{aligned} \tag{A.9}$$

We define the corresponding Lie groups as in the previous section.

Definition A.12: The matrix Lie group  $\{\exp \mathcal{L}\}_G$  is simple (semi-simple) if  $\mathcal{L}$  is simple (semisimple).

Again, Definition A.12 is equivalent to the usual definition in term of properties of the group [S1].

## APPENDIX B

### HARMONIC ANALYSIS ON COMPACT LIE GROUPS

#### B.1 Haar Measure and Group Representations

In this section we summarize some facts from the theory of integration and representations for compact Lie groups. For details see references [C3], [D4], [L7], [S8], [T1], and [H4].

Lemma B.1: A compact Lie group  $G$  has a regular Borel measure  $\mu$  (the Haar measure) satisfying the properties

- (1)  $\mu(G) < \infty$
- (2) (Left invariance)  $\mu(gE) = \mu(E)$   
for any  $g \in G$  and Borel set  $E \subset G$
- (3) (Right invariance)  $\mu(Eg) = \mu(E)$   
for any  $g \in G$  and Borel set  $E \subset G$

We assume henceforth that the Haar measure is normalized so that  $\int_G d\mu(g) = 1$ ;  $d\mu(g)$  will also be denoted  $dg$ . This normalized bi-invariant measure is unique. We now turn to the representations of compact Lie groups.

Definition B.1: Let  $G$  be a Lie group and  $V$  a (real or complex) finite-dimensional vector space. A finite-dimensional matrix representation of  $G$  is a continuous homomorphism  $D$  which maps  $G$  into the group of nonsingular linear transformations on  $V$ . That is,

- (1)  $D(g_1) D(g_2) = D(g_1 g_2)$  for  $g_1, g_2 \in G$
- (2)  $D(e) = I$ , the identity mapping on  $V$ , where  $e$  is the identity in  $G$

(3)  $g \mapsto D(g)v$  is a continuous mapping of  $G$  into  $V$  for each fixed  $v \in V$ . The vector space  $V$  is called the carrier space of the representation.

Definition B.2: The representations  $D^1$  on  $V^1$  and  $D^2$  on  $V^2$  are equivalent representations of  $G$  if there is a vector space isomorphism  $S: V^1 \rightarrow V^2$  such that  $D^1(g) = S^{-1}D^2(g)S$  for each  $g \in G$ . A unitary representation is a representation in which  $D(g)$  is a unitary transformation of  $V$  for all  $g \in G$ .

Theorem B.1: Any finite-dimensional representation of a compact Lie group is equivalent to a unitary representation.

Suppose that  $D^1$  and  $D^2$  are representations of a compact Lie group  $G$  on vector spaces  $V^1$  and  $V^2$ , respectively. Then we can construct other useful representations as follows.

Definition B.3: The direct sum  $D^1 \oplus D^2$  is the representation on  $V^1 \oplus V^2$  given by  $(D^1 \oplus D^2)(g)(v_1, v_2) = (D^1(g)v_1, D^2(g)v_2)$  for  $g \in G$  and  $(v_1, v_2) \in V^1 \oplus V^2$ . The tensor product representation  $D^1 \otimes D^2$  on  $V^1 \otimes V^2$  is given by  $(D^1 \otimes D^2)(g)(v_1 \otimes v_2) = (D^1(g)v_1) \otimes (D^2(g)v_2)$ . If  $D^1$  and  $D^2$  are matrix representations, then the direct sum is the matrix representation

$$(D^1 \oplus D^2)(g) = \begin{bmatrix} D^1(g) & 0 \\ 0 & D^2(g) \end{bmatrix}$$

and the direct product representation is given by the Kronecker product  $D^1(g) \otimes D^2(g)$  [B13].

Definition B.4: A subspace  $W \subset V$  is invariant under the representation  $D$  if, for each  $w \in W$  and  $g \in G$ ,  $D(g)w$  is also in  $W$ . A representation  $D$  on  $V$  is irreducible if  $V$  has no non-trivial  $D$ -invariant subspaces, and it is completely reducible if it is equivalent to a direct sum of irreducible representations.

Theorem B.2: Any finite-dimensional representation of a compact Lie group is completely reducible; in fact it is equivalent to a direct sum of irreducible unitary representations.

Another useful result is proved in [D5].

Theorem B.3: Any finite-dimensional representation  $D$  of a compact Lie group  $G$  leaves invariant some positive definite hermitian form  $Q(v,w)$ ; i.e.,

$$Q(D(g)v, D(g)w) = Q(v,w) \tag{B.1}$$

If  $D$  is a matrix representation and  $Q(v,w) = v'Qw$  (where  $Q$  is positive definite), then (B.1) becomes

$$\overline{D}(g) Q D(g) = Q \tag{B.2}$$

where  $\overline{D}$  denotes the hermitian transpose of  $D$ .

## B.2 Schur's Orthogonality Relations

Without loss of generality, we will henceforth consider all finite-dimensional representations to be matrix representations.

Theorem B.4: Suppose that  $D^1$  and  $D^2$  are inequivalent irreducible finite-dimensional unitary representations of a compact Lie group  $G$ , with matrix elements  $D_{ij}^1(g)$  and  $D_{ij}^2(g)$  respectively. Then

$$\int_G D_{im}^{\ell}(g) [D_{jn}^k(g)]^* dg = \frac{1}{n_{\ell}} \delta_{k\ell} \delta_{ij} \delta_{mn} \quad (B.3)$$

where \* denotes complex conjugate,  $n_{\ell}$  is the dimension of  $D^{\ell}(g)$ , and  $\delta_{ij} = 1$  if  $i = j$ ,  $\delta_{ij} = 0$  elsewhere.

Before proceeding with the Peter-Weyl Theorem, we state a result which applies Theorem B.4 to the reduction of an arbitrary representation into a direct sum of irreducible representations.

Definition B.5: The character associated with a matrix representation of  $G$  is the function  $\chi$  defined by

$$\chi(g) = \text{trace } D(g) = \sum_{i=1}^n D_{ii}(g) \quad (B.4)$$

Suppose  $\chi$ ,  $\chi^1$ , and  $\chi^2$  are the characters of the representations  $D$ ,  $D^1$ , and  $D^2$ , respectively. If  $D(g) = D^1(g) \oplus D^2(g)$ , then

$$\chi(g) = \chi^1(g) + \chi^2(g) \quad (B.5)$$

If  $D(g) = D^1(g) \otimes D^2(g)$ , then

$$\chi(g) = \chi^1(g)\chi^2(g). \quad (B.6)$$

One can also show [T1] that the representations  $D^1$  and  $D^2$  are equivalent if and only if  $\chi^1 = \chi^2$ .

According to Theorem B.2, any finite dimensional representation  $D$  of the compact Lie group  $G$  is equivalent to the direct sum of irreducible unitary representations

$$D(g) \approx D^{\ell_1}(g) \oplus \dots \oplus D^{\ell_p}(g) \quad (B.7)$$

Then by (B.5),

$$\chi(g) = \chi^{l_1}(g) + \dots + \chi^{l_p}(g) \quad (\text{B.8})$$

and hence

$$\chi(g) = \sum v_{l_i} \chi^{l_i}(g) \quad (\text{B.9})$$

where  $\chi^{l_i}$  is the character of  $D^{l_i}$ ,  $\chi$  is the character of  $D$ ,  $v^{l_i}$  is the number of times the irreducible representation  $D^{l_i}$  occurs in the sum (B.7), and the summation is over the set of equivalence classes of finite-dimensional irreducible representations of  $G$ . The following corollaries to Theorem B.4 are immediate.

Corollary B.1: The characters of the irreducible unitary representations  $D^1$  and  $D^2$  of the compact Lie group  $G$  satisfy

$$\int_G \chi^1(g) [\chi^2(g)]^* dg = \begin{cases} 1, & \text{if } D^1 \text{ and } D^2 \text{ are equivalent} \\ 0, & \text{otherwise} \end{cases} \quad (\text{B.10})$$

Furthermore, if a representation  $D$  is decomposed as in (B.7) - (B.9), then

$$v_{l_i} = \int_G \chi(g) [\chi^{l_i}(g)]^* dg \quad (\text{B.11})$$

Corollary B.2: Let  $D^1$  and  $D^2$  be irreducible representations of the compact Lie group  $G$ . Assume that  $D^1 \otimes D^2$  is equivalent to  $D^{l_1} \oplus \dots \oplus D^{l_p}$ , where the  $D^{l_i}$  are irreducible representations. Then

$$v_{l_i} = \int_G \chi^1(g) \chi^2(g) [\chi^{l_i}(g)]^* dg \quad (\text{B.12})$$



In the case that  $G$  is semisimple, Steinberg [S9],[B20],[J4] gives an alternate formula for  $v_{\ell_i}$  of Corollary B.2.

### B.3 The Peter-Weyl Theorem

In this section we state the major result in harmonic analysis on compact Lie groups [C3],[D4],[H4],[L7],[S8],[T1],[W11].

Definition B.6: The representative ring of a compact Lie group is the ring generated over the field of complex numbers by the set of all continuous functions  $D_{ij}$  which are matrix elements of some unitary irreducible representation  $D$ .

Theorem B.5 (The Peter-Weyl Theorem): Let  $G$  be a compact Lie group.

(a) The representative ring is dense in the space of complex-valued continuous functions on  $G$  in the uniform norm. That is, if  $f$  is a continuous function on  $G$ , and if  $\epsilon > 0$  is given, then there is a function  $\tilde{f}$  in the representative ring such that  $|f(g) - \tilde{f}(g)| < \epsilon$  for all  $g \in G$ .

(b) Let  $\Lambda$  be the set of equivalence classes of finite-dimensional irreducible representations of  $G$ . For each  $\alpha \in \Lambda$ , pick a unitary representation  $D^\alpha$ . If  $f \in L_2(G)$ , define the Fourier coefficient

$$\hat{f}_{ij}^\alpha = \int_G f(g) [D_{ij}^\alpha(g)]^* dg \quad (B.13)$$

Then the set of functions  $\{\sqrt{n_\alpha} D_{ij}^\alpha\}$  is a complete orthonormal set in  $L_2(G)$ ; i.e., we have the Parseval identity

$$\|f\|_2^2 \triangleq \int_G |f(g)|^2 dg = \sum_{\alpha \in \Lambda} \sum_{i,j=1}^{n_\alpha} |\sqrt{n_\alpha} \hat{f}_{ij}^\alpha|^2 \quad (\text{B.14})$$

where  $n_\alpha$  is defined in Theorem B.4.

The sum in (B.14) is defined in [R2, p. 84]; notice that (B.14) implies that the set of all  $\alpha$  such that  $\hat{f}_{ij}^\alpha \neq 0$  for some  $i$  and  $j$  is at most countable.

The Peter-Weyl Theorem thus yields the direct sum decomposition

$$L_2(G) = \bigoplus_{\alpha \in \Lambda} H_\alpha \quad (\text{B.15})$$

where  $H_\alpha$  denotes the vector space spanned by the  $(n_\alpha)^2$  functions  $\{D_{ij}^\alpha; i,j=1,\dots,n_\alpha\}$ .

#### B.4 The Laplacian

The Laplacian on a compact Lie group is closely connected with the theory of harmonic analysis presented in the previous sections.

Theorem B.6 [S8, p. 35]: Let  $G$  be a compact Lie group. There exists a second-order differential operator  $\Delta$  on  $G$  (the Laplacian), such that

(a)  $\Delta$  is bi-invariant; i.e., for all  $f \in C^\infty(G)$  and  $h \in G$ ,

$$\Delta(R_h f) = R_h(\Delta f) \quad (\text{B.16})$$

$$\Delta(L_h f) = L_h(\Delta f) \quad (\text{B.17})$$

where  $R_h$  is the right translation defined by  $(R_h f)(g) = f(gh)$ , and  $L_h$  is the left translation  $(L_h f)(g) = f(h^{-1}g)$ ;

(b)  $\Delta$  is elliptic;

(c)  $\Delta$  is formally self-adjoint; i.e., for any  $f_1, f_2 \in C^\infty(G)$

$$\int_G f_1(g) [\Delta f_2(g)] * dg = \int_G [\Delta f_1(g)] f_2^*(g) dg$$

(d)  $\Delta$  maps constant functions to zero.

If  $G$  is a compact matrix Lie group and  $\{A_1, \dots, A_N\}$  is a basis for the Lie algebra of  $G$ , then the Laplacian can be expressed in the form

$$\Delta = \sum_{i,j=1}^N Q_{ij} D_i D_j \tag{B.18}$$

where  $Q$  is a symmetric positive definite matrix and the differential operators  $D_i$  are defined as follows: let  $f$  be a function on the group  $G$ ; then we define for  $g \in G$

$$(D_i f)(g) \triangleq \left. \frac{d}{dt} f((\exp(A_i t)) \cdot g) \right|_{t=0} \tag{B.19}$$

We note that the Laplacian is not necessarily unique; however, it is unique if  $G$  is simple [S8, p. 36]. We will subsequently work with a single differential operator  $\Delta$  on  $G$  satisfying Theorem B.6; however, a different choice of  $Q$  in (B.18) will define an equally valid Laplacian.

It can be shown that  $\Delta$  is the Laplace-Beltrami operator on  $G$  corresponding to a suitably defined bi-invariant Riemannian metric on  $G$  (see [H3], [S8], [W11]). A Riemannian metric on a manifold  $M$  is a smooth choice of a positive definite inner product  $\langle, \rangle_m$  on the tangent space  $M_m$  at each point  $m \in M$ . If  $\phi: m \rightarrow (x_1(m), \dots, x_n(m))$  is a coordinate system valid on an open set  $U \subset M$ , we define the functions  $g_{ij}, g^{ij}, \bar{g}$  on  $U$  by

$$g_{ij}^{(m)} = \left\langle \frac{\partial}{\partial x_i} \middle|_m, \frac{\partial}{\partial x_j} \middle|_m \right\rangle_m \quad (\text{B.20})$$

$$\sum_{j=1}^n g_{ij}^{(m)} g^{jk} = \delta_{ik} \quad (\text{B.21})$$

$$\bar{g}^{(m)} = |\det(g_{ij}^{(m)})| \quad (\text{B.22})$$

Then the Laplace-Beltrami operator in terms of local coordinates is

$$\Delta f = \frac{1}{\sqrt{\bar{g}}} \sum_i \frac{\partial}{\partial x_i} \left( \sum_j g^{ji} \sqrt{\bar{g}} \frac{\partial f}{\partial x_j} \right) \quad (\text{B.23})$$

The next theorem relates the eigenfunctions of the Laplacian to the representative ring.

Theorem B.7 [S8, p. 40], [W11, p. 257]: Let  $G$  be a compact Lie group, and let  $H_\alpha$  be defined as in equation (B.15). Then each function  $\phi \in H_\alpha$  is an eigenfunction of the bi-invariant Laplacian  $\Delta$ , and all  $\phi \in H_\alpha$  have the same eigenvalue  $\lambda_\alpha$ . Conversely, each eigenfunction  $\phi$  of the Laplacian is an element of the representative ring.

Hence, harmonic analysis on a compact Lie group can be performed either in terms of the representative ring or the eigenfunctions of the bi-invariant Laplacian, since these two sets of functions are the same.

### B.5 Harmonic Analysis on $SO(n)$ and $S^n$

In this section we discuss the application of the results of the previous sections to the special orthogonal group  $SO(n)$  and the  $n$ -sphere  $S^n$ . The results for  $SO(3)$  and  $S^2$  will be discussed in detail.

The Lie group  $SO(n)$  is defined by

$$SO(n) = \{X \in R^{n \times n} \mid X'X = I, \det X = +1\} \quad (B.24)$$

The theory of representations of  $SO(n)$  is discussed in [B23], [H5], [H6], [J5], [L9], [M16]. We will present only a brief summary of the subject; the reader is referred to the references for details. Each irreducible representation of  $SO(n)$  can be characterized by a set of  $k$  integers (where  $n = 2k + 1$  if  $n$  is odd, and  $n = 2k$  if  $n$  is even). This set of  $k$  integers can be either the highest weight  $(\lambda) = (\lambda_1, \dots, \lambda_k)$  (see [B20], [B23], [H6]) or the Young pattern  $[f] = [f_1, \dots, f_k]$ , where  $f_i \geq f_{i+1}$  and  $f_i \geq 0$  (see [H5], [J5], [L9], [M16]). The two notions are related by

$$\begin{aligned} \lambda_i &= f_i - f_{i+1} & \text{for } i = 1, \dots, k-1 \\ \lambda_k &= f_k \end{aligned} \quad (B.25)$$

We denote an irreducible representation corresponding to  $(\lambda)$  or  $[f]$  by  $D^{(\lambda)}$  or  $D^{[f]}$ ; the dimension of  $D^{(\lambda)}$  is denoted by  $n_{N(\lambda)}$ , and is computed in [B23], [H5]. For  $X \in SO(n)$ , the representation  $D^{(1,0,\dots,0)}(X) = X$  is called the self-representation.

Given a matrix representation  $D$  of  $SO(n)$ , Theorem B.2 states that there exists a nonsingular matrix  $P$  such that, for  $g \in SO(n)$

$$D(g) = P(D^{(\lambda_1)}(g) \oplus \dots \oplus D^{(\lambda_k)}(g))P^{-1} \quad (B.26)$$

where the  $\{D^{(\lambda_i)}\}$  are irreducible representations. It is often necessary to compute the transformation matrix  $P$ ; in particular, one must sometimes decompose the tensor product of two representations. Consider the tensor product  $D^{(j)} \otimes D^{(k)}$  of two unitary irreducible representations. The

number of times  $\nu_{\ell_i}$  that the irreducible representation  $D^{(\ell_i)}$  occurs in the decomposition of  $D^{(j)} \otimes D^{(k)}$  can be calculated from the highest weights, the Young tableaux, or the characters via (B.12); the result is the Clebsch-Gordan series [B20], [J5], [L9], [M16]

$$D^{(j)} \otimes D^{(k)} \approx \bigoplus D^{(\ell_i)} \quad (\text{B.27})$$

The elements of the matrix which transforms  $D^{(j)} \otimes D^{(k)}$  into the direct sum (B.27) can also be computed [J5], [L9]; these elements are known as the Clebsch-Gordan, Wigner, or vector coupling coefficients.

Now we consider the special case  $SO(3)$ . Any matrix  $R$  in  $SO(3)$  has an Euler angle representation of the form [T1]

$$R = Z(\phi)X(\theta)Z(\psi) \quad (\text{B.28})$$

where

$$Z(\phi) = \begin{bmatrix} \cos\phi & -\sin\phi & 0 \\ \sin\phi & \cos\phi & 0 \\ 0 & 0 & 1 \end{bmatrix}, \quad X(\theta) = \begin{bmatrix} 1 & 0 & 0 \\ 0 & \cos\theta & -\sin\theta \\ 0 & \sin\theta & \cos\theta \end{bmatrix} \quad (\text{B.29})$$

and the Euler angles  $\phi, \theta, \psi$  have the domain  $0 \leq \phi < 2\pi, 0 \leq \theta \leq \pi, 0 \leq \psi < 2\pi$ . The element of  $SO(3)$  with the representation (B.28) will be denoted by  $R(\phi, \theta, \psi)$  or just  $(\phi, \theta, \psi)$ .

In the Euler angle coordinates, the bi-invariant Riemannian metric on  $SO(3)$  is given by [B22]

$$(ds)^2 = d\theta^2 + d\phi^2 + 2\cos\theta d\phi d\psi + d\psi^2 \quad (\text{B.30})$$

i.e., the matrix  $g$  of (B.20) is given by

$$g(\phi, \theta, \psi) = \begin{bmatrix} 1 & 0 & \cos\theta \\ 0 & 1 & 0 \\ \cos\theta & 0 & 1 \end{bmatrix} \quad (\text{B.31})$$

The (unnormalized) Haar measure is thus

$$d\mu(\phi, \theta, \psi) = \sqrt{|\det g|} d\phi d\theta d\psi = \sin\theta d\phi d\theta d\psi \quad (\text{B.32})$$

The bi-invariant Laplace-Beltrami operator corresponding to the metric (B.30) is given by [B22]

$$\Delta_{SO(3)} = \frac{1}{\sin\theta} \frac{\partial}{\partial\theta} (\sin\theta \frac{\partial}{\partial\theta}) + \frac{1}{\sin^2\theta} \left( \frac{\partial^2}{\partial\phi^2} - 2 \cos\theta \frac{\partial^2}{\partial\phi\partial\psi} + \frac{\partial^2}{\partial\psi^2} \right) \quad (\text{B.33})$$

For  $SO(3)$ , notice that  $n = 3$  and  $k = 1$ ; thus the highest weights and Young tableaux, and hence the irreducible representations, are characterized by a single integer. Talman [T1] computes a sequence  $D^\ell(\phi, \theta, \psi)$ ,  $\ell = 0, 1, \dots$ , of unitary irreducible representations of  $SO(3)$ ; its matrix elements are given by

$$D_{mn}^\ell(\phi, \theta, \psi) = i^{m-n} e^{-im\phi} d_{mn}^\ell(\theta) e^{-in\psi} \quad (\text{B.34})$$

where

$$d_{mn}^\ell(\theta) = \sum_t (-1)^t \frac{[(\ell+m)!(\ell-m)!(\ell+n)!(\ell-n)!]^{1/2}}{(\ell+m-t)!(t+n-m)!t!(\ell-n-t)!} \cdot \cos^{2\ell+m-n-2t} \left( \frac{\theta}{2} \right) \sin^{2t+n-m} \left( \frac{\theta}{2} \right) \quad (\text{B.35})$$

for  $-\ell \leq m, n \leq \ell$ .

Here  $t$  is summed over all nonnegative integers such that the arguments of the factorial functions in (B.35) are nonnegative; i.e.,

$$m-n \leq t \leq \ell + m, \quad 0 \leq t \leq \ell - n$$

In fact, these are (up to equivalence) all of the irreducible representations of  $SO(3)$ . The Peter-Weyl Theorem yields the decomposition

$$L_2(SO(3)) = \bigoplus_{\ell} H_{\ell} \quad (\text{B.36})$$

where  $H_{\ell}$  is the vector space spanned by the  $(2\ell+1)^2$  functions  $\{D_{mn}^{\ell}; m, n = -\ell, \dots, \ell\}$ .

The Clebsch-Gordan series for  $SO(3)$  is given by [H4, p. 135], [T1, p. 116]

$$D^j \otimes D^k \approx \bigoplus_{\ell=|j-k|}^{j+k} D^{\ell} \quad (\text{B.37})$$

The elements of the matrix which transforms  $D^j \otimes D^k$  into the direct sum (B.37) are defined as follows [T1, p. 118]. Assume that

$$D_{m',m}^j(\phi, \theta, \psi) D_{n',n}^k(\phi, \theta, \psi) = \sum_{\ell, p, p'} (2\ell+1) \begin{pmatrix} j & k & \ell \\ m & n & p \end{pmatrix}^* \begin{pmatrix} j & k & \ell \\ m' & n' & p' \end{pmatrix} D_{p',p}^{\ell}(\phi, \theta, \psi)^* \quad (\text{B.38})$$

where  $|j-k| \leq \ell \leq j+k$  and  $-\ell \leq p, p' \leq \ell$ , and  $*$  denotes complex conjugate.

The coefficients  $\begin{pmatrix} j & k & \ell \\ m & n & p \end{pmatrix}$  (known as the 3-j, Clebsch-Gordan, or vector coupling coefficients) are given by



$$\begin{aligned} \binom{j \quad k \quad \ell}{m \quad n \quad p} &= (-1)^{2j-k+n} \left[ \frac{(j+k-\ell)! (k+\ell-j)! (\ell+j-k)! (\ell+p)! (\ell-p)!}{(j+k+\ell+1)! (j+m)! (j-m)! (k+n)! (k-n)!} \right]^{1/2} \\ &\cdot \sum_t (-1)^t \frac{(\ell+j-n-t)! (k+n+t)!}{(\ell+p-t)! (t+k-j-p)! t! (\ell-k+j-t)!} \end{aligned} \quad (\text{B.39})$$

where the sum is over integral values of  $t$  such that the arguments of the factorial functions in (B.39) are nonnegative. These coefficients are widely used by physicists [W19], and are tabulated in [B24].

The  $n$ -sphere  $S^n = \{x \in \mathbb{R}^n \mid x'x = 1\}$  is diffeomorphic to the homogeneous space  $SO(n)/SO(n-1)$ . Harmonic analysis on  $S^n$  is studied in terms of the spherical harmonics [D4], [E1], [S13], [T1], [V1]. Let  $\mathcal{P}_\ell$  denote the space of homogeneous polynomials of degree  $\ell$  on  $\mathbb{R}^{n+1}$  (i.e.,  $f(cx_1, \dots, cx_{n+1}) = c^\ell f(x_1, \dots, x_{n+1})$ ). Then the space  $H_\ell$  of spherical harmonics of degree  $\ell$  on  $S^n$  can be characterized in the following equivalent ways:

(1) the restriction to  $S^n$  of the subspace  $\mathcal{H}_\ell = \{f \in \mathcal{P}_\ell \mid \Delta_{\mathbb{R}^{n+1}} f = 0\}$  of harmonic homogeneous polynomials, where

$$\Delta_{\mathbb{R}^{n+1}} \triangleq \sum_{i=1}^n \frac{\partial^2}{\partial x_i^2} \quad (\text{B.40})$$

(2) the restriction to  $S^n$  of the subspace of  $\mathcal{P}_\ell$  which is orthogonal to the subspace  $\{(x_1^2 + \dots + x_n^2)f(x_1, \dots, x_n) \mid f \in \mathcal{P}_{\ell-2}\}$  (each of these subspaces is invariant under the action of  $SO(n+1)$ ).

(3) the irreducible subspace of  $L_2(S^n)$  which is the carrier space of the irreducible representation of  $SO(n+1)$  of highest weight  $(k, 0, \dots, 0)$  (this representation is obtained by reducing the representation  $[D(X)f](x) = f(X^{-1}x)$ , where  $X \in SO(n+1)$ ,  $x \in S^n$ ,  $f \in L_2(S^n)$ );

(4) the eigenspace of the  $SO(n+1)$ -invariant Laplacian  $\Delta_{S^n}$  on  $S^n$  with eigenvalue  $-\ell(n-1+\ell)$ .

Property (2) implies that each  $f \in \mathcal{P}_\ell$  has a unique expansion

$$f = \sum_{j=0}^{\lfloor \frac{\ell}{2} \rfloor} ||x||^{2j} f_{\ell-2j} \quad (\text{B.41})$$

where  $f_{\ell-2j} \in \mathcal{H}_{\ell-2j}$  and  $\lfloor t \rfloor$  is the largest integer  $\leq t$  (Brockett [B3] also discusses this point). One can show [D4, p. 109] that the span of  $\{H_\ell, \ell=1,2,\dots\}$  is dense in the space of continuous functions on  $S^n$  and in  $L_p(S^n)$ ,  $1 \leq p < \infty$ . Notice also that, using property (3) and the Clebsch-Gordan coefficients for  $SO(n+1)$ , we can write the product of two spherical harmonics as a linear combination of spherical harmonics.

Now we turn to the 2-sphere  $S^2$ . Any point  $(x_1, x_2, x_3)$  on  $S^2$  can be expressed in the polar coordinates  $(\theta, \phi)$ , where  $0 \leq \theta \leq \pi$ ,  $0 \leq \phi < 2\pi$ , by defining

$$x_1 = \cos\theta; \quad x_2 = \sin\theta \cos\phi; \quad x_3 = \sin\theta \sin\phi \quad (\text{B.42})$$

Notice that the point  $(\theta, \phi)$  on  $S^2$  can be viewed as the coset  $\{(\phi, \theta, \psi), \psi \in [0, 2\pi)\}$ . In polar coordinates, the Riemannian metric invariant under the action of  $SO(3)$  is

$$(ds)^2 = d\theta^2 + \sin^2\theta d\phi^2 \quad (\text{B.43})$$

and the corresponding Riemannian measure is

$$d\mu(\theta, \phi) = \sin\theta d\theta d\phi \quad (\text{B.44})$$

The corresponding invariant Laplace-Beltrami operator is [B3]

$$\Delta_{S^2} = \frac{1}{\sin\theta} \left[ \frac{\partial}{\partial\theta} \left( \sin\theta \frac{\partial}{\partial\theta} \right) + \frac{1}{\sin\theta} \frac{\partial^2}{\partial\phi^2} \right] \quad (\text{B.45})$$

Since functions on  $S^2$  can be viewed as functions on  $SO(3)$  which are independent of  $\psi$ , the Laplace-Beltrami operator  $\Delta_{S^2}$  can also be obtained from  $\Delta_{SO(3)}$  (see (B.33)) by setting  $\frac{\partial}{\partial\psi} = 0$ .

We now consider the spherical harmonics on  $S^2$ . The normalized spherical harmonics of degree  $\ell$  are defined by [T1]

$$Y_{\ell m}(\theta, \phi) = (-1)^m \left[ \frac{(\ell-m)!}{(\ell+m)!} \frac{(2\ell+1)}{4\pi} \right]^{1/2} P_{\ell m}(\cos\theta) e^{im\phi} \quad (\text{B.46})$$

$$Y_{\ell, -m}(\theta, \phi) = (-1)^m Y_{\ell m}^*(\theta, \phi) \quad (\text{B.47})$$

for  $\ell = 0, 1, \dots$  and  $m = 0, 1, \dots, \ell$ , where  $P_{\ell m}(\cos\theta)$  are the associated Legendre functions. These functions satisfy the four properties of spherical harmonics listed above. In particular, property (3) implies that [T1]

$$\begin{aligned} Y_{\ell m}(\theta, \phi) &= \left[ \frac{2\ell+1}{4\pi} \right]^{1/2} D_{m0}^{\ell} \left( \phi + \frac{\pi}{2}, \theta, 0 \right)^* \\ &= \left[ \frac{2\ell+1}{4\pi} \right]^{1/2} e^{im\phi} d_{m0}^{\ell}(\theta) \end{aligned} \quad (\text{B.48})$$

The product of two spherical harmonics can be readily expanded by employing (B.38) with  $m = n = 0$ :

$$\begin{aligned} &Y_{\ell m}(\theta, \phi) Y_{\ell' m'}(\theta, \phi) \\ &= (-1)^{m+m'} \sum_{j=|\ell-\ell'|}^{\ell+\ell'} (2j+1) \begin{pmatrix} \ell & \ell' & j \\ m & m' & -(m+m') \end{pmatrix} \begin{pmatrix} \ell & \ell & j \\ 0 & 0 & 0 \end{pmatrix} Y_{j, m+m'}(\theta, \phi) \end{aligned} \quad (\text{B.49})$$

APPENDIX C

THE FUBINI THEOREM FOR CONDITIONAL EXPECTATION

Many of the proofs in Chapter 5 and Appendix D require the interchange of the operations of conditional expectation and integration with respect to time. In this appendix we will prove a theorem which justifies this interchange under certain hypotheses.

Let  $X$  be a random variable defined on a probability space  $(\Omega, \mathcal{F}, P)$ , and assume that the expected value  $E[X]$  is well-defined. Let  $\mathcal{F}'$  be a sub- $\sigma$  field of  $\mathcal{F}$ .

Definition C.1 [W8]: The conditional expectation  $E^{\mathcal{F}'} X \triangleq E[X|\mathcal{F}']$  is  $P$ -almost surely uniquely defined by the following two conditions:

- (a)  $E^{\mathcal{F}'} X$  is measurable with respect to  $\mathcal{F}'$
- (b) Let  $I_A$  denote the indicator function of the set  $A$ . Then

$$E[I_A E^{\mathcal{F}'} X] = E[I_A X] \text{ for all } A \in \mathcal{F}' \quad (\text{C.1})$$

We will first need the usual Fubini theorem [R2].

Lemma C.1 (Fubini's Theorem): Let  $(\Omega_i, \mathcal{F}_i, \mu_i)$ ,  $i = 1, 2$ , be  $\sigma$ -finite measure spaces, let  $\mu_1 \times \mu_2$  be the product measure defined on  $\mathcal{F}_1 \times \mathcal{F}_2$ . Also, if  $h: \Omega_1 \times \Omega_2 \rightarrow \mathbb{R}$ , define the sections  $h_{\omega_1}: \Omega_2 \rightarrow \mathbb{R}$  and  $h_{\omega_2}: \Omega_1 \rightarrow \mathbb{R}$  by

$$h_{\omega_1}(\omega_2) = h(\omega_1, \omega_2) \quad \text{for } \omega_2 \in \Omega_2 \quad (\text{C.2})$$

$$h_{\omega_2}(\omega_1) = h(\omega_1, \omega_2) \quad \text{for } \omega_1 \in \Omega_1 \quad (\text{C.3})$$

(a) If  $h: \Omega_1 \times \Omega_2 \rightarrow \mathbb{R}$  is  $\mathcal{F}_1 \times \mathcal{F}_2$ -measurable and  $\mu_1 \times \mu_2$ -integrable, then  $h_{\omega_1}: \Omega_2 \rightarrow \mathbb{R}$  is  $\mu_2$ -integrable for  $\mu_1$ -almost all  $\omega_1$ , and  $h_{\omega_2}: \Omega_1 \rightarrow \mathbb{R}$  is  $\mu_1$ -integrable for  $\mu_2$ -almost all  $\omega_2$ . Furthermore, the functions

$$\omega_1 \rightarrow \int_{\Omega_2} h_{\omega_1} d\mu_2 \quad \text{and} \quad \omega_2 \rightarrow \int_{\Omega_1} h_{\omega_2} d\mu_1$$

defined  $\mu_1$ -almost everywhere and  $\mu_2$ -almost everywhere, are  $\mu_1$ -integrable and  $\mu_2$ -integrable, respectively, and

$$\int_{\Omega_1 \times \Omega_2} h d(\mu_1 \times \mu_2) = \int_{\Omega_2} \left( \int_{\Omega_1} h_{\omega_2} d\mu_1 \right) d\mu_2 = \int_{\Omega_1} \left( \int_{\Omega_2} h_{\omega_1} d\mu_2 \right) d\mu_1 \quad (\text{C.4})$$

(b) If  $h: \Omega_1 \times \Omega_2 \rightarrow \mathbb{R}$  is  $\mathcal{F}_1 \times \mathcal{F}_2$ -measurable and  $\int_{\Omega_1} \left( \int_{\Omega_2} |h_{\omega_1}| d\mu_2 \right) d\mu_1$

is finite, then  $h$  is  $\mu_1 \times \mu_2$ -integrable, and thus the conclusions of (a) hold.

Theorem C.1 (Fubini Theorem for Conditional Expectation): Let  $(\Omega, \mathcal{F}, P)$  be a probability space and consider the measure space  $([0, t], \mathcal{B}, m)$ , where  $t$  is finite and  $m$  is the Lebesgue measure on the  $\sigma$ -field of Borel sets in  $[0, t]$ . Let  $\mathcal{F}'$  be a sub- $\sigma$  field of  $\mathcal{F}$ . Assume that

(a)  $f: [0, t] \times \Omega \rightarrow \mathbb{R}$  is  $\mathcal{B} \times \mathcal{F}$ -measurable

(b)  $E^{\mathcal{F}'} [f]: [0, t] \times \Omega \rightarrow \mathbb{R}$  is  $\mathcal{B} \times \mathcal{F}$ -measurable

(c)  $\int_0^t \left( \int_{\Omega} I_A(\omega) |f_s(\omega)| dP(\omega) \right) ds$  is finite for all  $A \in \mathcal{F}'$ .

Then

$$\int_0^t E^{\mathcal{F}'} [f_s(\omega)] ds = E^{\mathcal{F}'} \left[ \int_0^t f_\omega(s) ds \right] \quad (\text{C.5})$$

(P-almost surely).

Proof: Since  $E^{\mathcal{F}'} [f_\omega(s)]$  is  $\mathcal{F}'$ -measurable, it follows that

$$\int_0^t E^{\mathcal{F}'} [f_\omega(s)] ds \text{ is } \mathcal{F}'\text{-measurable. Thus, by Definition C.1, we need}$$

only show that, for all  $A \in \mathcal{F}'$ ,

$$E[I_A(\omega) \int_0^t E^{\mathcal{F}'} [f_s(\omega)] ds] = E[I_A(\omega) \int_0^t f_\omega(s) ds] \quad (\text{C.6})$$

However,

$$\begin{aligned} E[I_A(\omega) \int_0^t E^{\mathcal{F}'} [f_s(\omega)] ds] \\ = \int_{\Omega} I_A(\omega) \left( \int_0^t E^{\mathcal{F}'} [f_s(\omega)] ds \right) dP(\omega) \end{aligned} \quad (\text{C.7})$$

$$= \int_{\Omega} \left( \int_0^t I_A(\omega) E^{\mathcal{F}'} [f_s(\omega)] ds \right) dP(\omega) \quad (\text{C.8})$$

$$= \int_0^t \left( \int_{\Omega} I_A(\omega) E^{\mathcal{F}'} [f_s(\omega)] dP(\omega) \right) ds \quad (\text{C.9})$$

$$= \int_0^t \left( \int_{\Omega} I_A(\omega) f_s(\omega) dP(\omega) \right) ds \quad (\text{C.10})$$

$$= \int_{\Omega} I_A(\omega) \left( \int_0^t f_\omega(s) ds \right) dP(\omega) \quad (\text{C.11})$$

$$= E[I_A(\omega) \int_0^t f_\omega(s) ds] \quad (C.12)$$

Equations (C.7) and (C.12) are just the definition of expectation, while (C.10) follows from the definition of conditional expectation. Equation (C.8) is due to the fact that  $I_A(\omega)$  is independent of  $t$ . Since the product of two measurable functions is measurable [R2], the integrands in (C.8) and (C.10) are  $\mathcal{B} \times \mathcal{F}$ -measurable. Thus the application of Lemma C.1 (b) to (C.10) yields (C.11), because of assumption (c). Notice that

$$\begin{aligned} & \int_0^t \left( \int_{\Omega} I_A(\omega) |E^{\mathcal{F}'} [f_s(\omega)]| dP(\omega) \right) ds \\ & \leq \int_0^t \left( \int_{\Omega} I_A(\omega) E^{\mathcal{F}'} [ |f_s(\omega)| ] dP(\omega) \right) ds \\ & = \int_0^t \left( \int_{\Omega} I_A(\omega) |f_s(\omega)| dP(\omega) \right) ds < \infty \end{aligned} \quad (C.13)$$

Hence, Lemma C.1 (b) also implies (C.9).

A similar result holds for the interchange of conditional expectation with multiple integrals over  $([0,t] \times \dots \times [0,t_n], \mathcal{B} \times \dots \times \mathcal{B}, m \times \dots \times m)$ .

It can easily be shown that the application of this theorem is justified in Chapter 5 and Appendix D, since the integrands are just products of Gaussian random processes.

APPENDIX D

PROOFS OF THEOREMS 5.1 AND 5.2

D.1 Preliminary Results

In this section we present some preliminary results which are crucial in the proofs of Theorems 5.1 and 5.2. The first lemma follows easily from some identities of Miller [M11].

Lemma D.1: Let  $\mathbf{x} = [x_1, \dots, x_k]'$  be a Gaussian random vector with mean  $\mathbf{m}$ , covariance matrix  $\mathbf{P}$ , and characteristic function  $M_{\mathbf{x}}$ . Then, if  $\ell \leq k$ ,

$$\begin{aligned} \frac{\partial^\ell}{\partial u_1 \dots \partial u_\ell} M_{\mathbf{x}}(u_1, \dots, u_k) &= \{\epsilon_1 \dots \epsilon_\ell - \sum_{j_1 j_2} P_{j_1 j_2} \epsilon_{j_1} \dots \epsilon_{j_\ell} \\ &\quad + \sum_{j_1 j_2 j_3 j_4} P_{j_1 j_2} P_{j_3 j_4} \epsilon_{j_1} \dots \epsilon_{j_\ell} - \dots\} M_{\mathbf{x}}(u_1, \dots, u_k) \end{aligned} \tag{D.1}$$

where

$$\epsilon_j = im_j - \sum_{n=1}^k u_n P_{jn} \tag{D.2}$$

and the sums in (D.1) are over all possible combinations of pairs of the  $\{j_i, i=1, \dots, \ell\}$ . Also,



$$E[x_1 x_2 \dots x_k] = E[x_k] E[x_1 x_2 \dots x_{k-1}] + \sum_{j_1=1}^{k-1} P_{kj_1} E[x_{j_2} x_{j_3} \dots x_{j_{k-1}}] \quad (D.3a)$$

$$\begin{aligned} &= E[x_1 \dots x_i] E[x_{i+1} \dots x_k] + \sum_{j_1 \ell_{i+1}}^P E[x_{j_2} \dots x_{j_i}] E[x_{\ell_{i+2}} \dots x_{\ell_k}] \\ &+ \sum_{j_1 \ell_{i+1}}^P \sum_{j_2 \ell_{i+2}}^P E[x_{j_3} \dots x_{j_i}] E[x_{\ell_{i+3}} \dots x_{\ell_k}] + \dots \end{aligned} \quad (D.3b)$$

$$\begin{aligned} &= m_1 \dots m_k + \sum_{j_1 j_2}^P m_{j_3} \dots m_{j_k} \\ &+ \sum_{j_1 j_2}^P \sum_{j_3 j_4}^P m_{j_5} \dots m_{j_k} + \dots \end{aligned} \quad (D.3c)$$

where the sums in (D.3b, c) are defined as in (D.1); also, in (D.3b),  $\{j_\alpha, \alpha = 1, \dots, i\}$  is a permutation of  $\{1, \dots, i\}$  and  $\{\ell_\alpha, \alpha = i+1, \dots, k\}$  is a permutation of  $\{i+1, \dots, k\}$ .

In the remainder of this appendix it will be assumed that  $\xi$  and  $z$  are Gauss-Markov processes satisfying (5.1) and (5.3), respectively. We now define classes of random processes which occur as the  $j^{\text{th}}$  order term in a Volterra series expansion in  $\xi$  with separable kernels (see Section 5.1), and we prove some lemmas relating these to other relevant processes.

Definition D.1: The space  $\Lambda_j$  of Volterra terms of order  $j$  is the vector space over  $\mathbb{R}$  consisting of all scalar-valued random processes  $\lambda_j$  of the form

$$\lambda_j(t) = \sum_{i=1}^N \gamma_0^i(t) \lambda_j^i(t) \quad (D.4)$$

where

$$\lambda_j^i(t) = \int_0^t \int_0^{\sigma_1} \dots \int_0^{\sigma_{j-1}} \gamma_1^i(\sigma_1) \dots \gamma_j^i(\sigma_j) \xi_{k_{1,i}}(\sigma_1) \dots \xi_{k_{j,i}}(\sigma_j) d\sigma_1 \dots d\sigma_j \quad (\text{D.5})$$

where for each  $i$ ,  $\{\xi_{k_{1,i}}, \dots, \xi_{k_{j,i}}\}$  are not necessarily distinct elements of  $\xi$ , and  $\{\gamma_\ell^i\}$  are locally bounded, piecewise continuous, deterministic functions of time. We denote by  $\hat{\Lambda}_j$  the space of all processes

$$\lambda_j(t|z) \triangleq E[\lambda_j(t)|z^t], \text{ where } \lambda_j \in \Lambda_j.$$

The next lemma, which is due to Brockett [B27], shows that terms of the form (5.9) with  $i < j$  (more integrals than  $\xi_k$ 's) are in fact elements of  $\Lambda_i$ .

Lemma D.2: Let  $\xi$  satisfy (5.1), and consider the scalar-valued process

$$\eta(t) = \int_0^t \int_0^{\sigma_1} \dots \int_0^{\sigma_{j-1}} \gamma_1(\sigma_1) \dots \gamma_j(\sigma_j) \xi_{k_1}(\sigma_{m_1}) \dots \xi_{k_i}(\sigma_{m_i}) d\sigma_1 \dots d\sigma_j \quad (\text{D.6})$$

where  $\gamma_i$  are as in Definition D.1,  $m_n \neq m_\ell$  for  $n \neq \ell$ , and  $i < j$ . Then  $\eta \in \Lambda_i$ .

Proof: It is easy to show using the construction of Brockett [B25, Theorem 4] that  $\eta(t)$  has a realization as a time-varying bilinear system

$$\dot{x}(t) = A(t)x(t) + \sum_{\ell=1}^i \xi_{k_\ell}(t) B_\ell(t)x(t) \quad (\text{D.7})$$

$$\eta(t) = x_1(t) \quad (\text{D.8})$$

where  $A(t)$  and  $\{B_\ell(t)\}$  are strictly upper triangular matrices. The Volterra series for (D.7) can be expressed via the Peano-Baker series [B25], and the Volterra series is finite because  $A(t)$  and  $\{B_\ell(t)\}$  are upper triangular. In fact, because the original expression (D.6) contains only the product of  $i$  components of  $\xi$ , the Volterra expansion of  $\eta(t) = x_1(t)$  will contain only an  $i^{\text{th}}$  order term

$$\eta(t) = \int_0^t \int_0^{\sigma_1} \dots \int_0^{\sigma_{i-1}} \left[ \sum_{\ell=1}^m \gamma_1^\ell(\sigma_1) \dots \gamma_i^\ell(\sigma_i) \right] \xi_{n_1}(\sigma_1) \dots \xi_{n_i}(\sigma_i) d\sigma_1 \dots d\sigma_i \quad (\text{D.9})$$

where  $\{n_\ell, \ell = 1, \dots, i\}$  is a permutation of the  $\{k_\ell, \ell = 1, \dots, i\}$  of (D.6). Hence  $\eta \in \Lambda_i$ . ■

Recall that the conditional cross-covariance  $P(\sigma_1, \sigma_2, t)$  (defined in (5.13)) was shown to be nonrandom in Lemma 5.1; it can be computed from Kwakernaak's equations (5.17)-(5.19). The following lemma shows that  $P_{ij}(\sigma_1, \sigma_2, t)$  is a separable kernel.

Lemma D.3:  $P_{ij}(\sigma_1, \sigma_2, t)$  is a separable kernel; i.e., it can be expressed in the form

$$P_{ij}(\sigma_1, \sigma_2, t) = \sum_{k=1}^m \gamma_0^k(t) \gamma_1^k(\sigma_1) \gamma_2^k(\sigma_2) \quad (\text{D.10})$$

Proof: Assume  $\sigma_1 \leq \sigma_2 \leq t$ . Then it follows from (5.17) that, for arbitrary real numbers  $\alpha$ ,  $\beta$ , and  $\delta$ ,

$$\begin{aligned}
P(\sigma_1, \sigma_2, t) &= P(\sigma_1) \Psi'(\alpha, \sigma_1) \left[ \Psi'(\sigma_2, \alpha) - \int_{\sigma_2}^{\beta} \Psi'(\tau, \alpha) H'(\tau) R^{-1}(\tau) H(\tau) \Psi(\tau, \sigma_2) d\tau \cdot P(\sigma_2) \right. \\
&\quad \left. - \int_{\beta}^t \Psi'(\tau, \alpha) H'(\tau) R^{-1}(\tau) H(\tau) \Psi(\tau, \delta) d\tau \cdot \Psi(\delta, \sigma_2) P(\sigma_2) \right] \\
&\triangleq A(\sigma_1) [B(\sigma_2) + C(t)D(\sigma_2)] \tag{D.11}
\end{aligned}$$

Hence, if  $e_i$  denotes the  $i^{\text{th}}$  unit vector in  $R^n$ , it is obvious from (D.11) that

$$P_{ij}(\sigma_1, \sigma_2, t) = e_i' P(\sigma_1, \sigma_2, t) e_j \tag{D.12}$$

has the form (D.10) for some functions  $\{\gamma_\ell^m(t)\}$ . ■

The next lemma proves that certain processes which occur in the proof of Theorem 5.1 are elements of  $\Lambda_j$ .

Lemma D.4: Let  $\xi$  satisfy (5.1), and consider the scalar-valued process

$$\begin{aligned}
\eta(t) &= \int_0^t \int_0^{\sigma_1} \dots \int_0^{\sigma_{j-1}} P_{n_1 n_2}(\sigma_{m_1}, \sigma_{m_2}, t) \dots P_{n_{\ell-1} n_\ell}(\sigma_{m_{\ell-1}}, \sigma_{m_\ell}, t) \\
&\quad \cdot \gamma_1(\sigma_1) \dots \gamma_j(\sigma_j) \xi_{k_1}(\sigma_1) \dots \xi_{k_j}(\sigma_j) d\sigma_1 \dots d\sigma_j \tag{D.13}
\end{aligned}$$

where the  $m_i$  are arbitrary integers in  $\{1, \dots, i\}$  and  $P_{n_{i_1} n_{i_2}}$  are arbitrary elements of  $P$ . Then  $\eta \in \Lambda_j$ .

Proof: Since we have shown in Lemma D.3 that  $P_{n_{i_1} n_{i_2}}(\sigma_{m_{i_1}}, \sigma_{m_{i_2}}, t)$  is

a separable kernel, the kernel of the integral (D.13) is also a separable kernel. Hence  $\eta \in \Lambda_j$ . ■

Lemma D.4 implies that if  $\hat{\lambda}_j(t|t)$  can be computed with a finite dimensional estimator for all  $\lambda_j \in \Lambda_j$ , then  $\hat{\eta}(t|t)$  (where  $\eta$  is defined by (D.13)) is also "finite dimensionally computable" (FDC).

## D.2 Proofs of Theorems 5.1 and 5.2

The proofs of these two theorems are almost identical. We will prove Theorem 5.1; then we will explain how this proof is modified to prove Theorem 5.2.

Proof of Theorem 5.1: As stated in Section 5.2, we consider the  $j^{\text{th}}$  order Volterra term

$$\eta(t) = \int_0^t \int_0^{\sigma_1} \dots \int_0^{\sigma_{j-1}} \gamma_1(\sigma_1) \dots \gamma_j(\sigma_j) \cdot \xi_{k_1}(\sigma_1) \dots \xi_{k_j}(\sigma_j) d\sigma_1 \dots d\sigma_j \quad (\text{D.14})$$

The theorem is proved by induction on  $j$ , the order of the Volterra term. The proof for  $j=1$  is presented in Section 5.2. We now assume the theorem holds for  $j \leq i-1$  (i.e., we assume that  $E^t[e^{\xi_{\rho}(t)} \eta(t)]$  is FDC, where  $\eta \in \Lambda_j$ , for  $j \leq i-1$ ), and prove that it holds for  $j=i$ .

The proof is in two steps. We first reduce the problem to the computation of the elements of  $\hat{\Lambda}_i$  (see Definition D.1). We then show by induction that all of the processes in  $\hat{\Lambda}_i$  can be computed with finite dimensional estimators.

(i) We first consider the computation of  $\hat{x}(t|t)$ , where

$$x(t) = e^{\xi_\ell(t)} \eta(t) \quad (D.15)$$

Now

$$\begin{aligned} \hat{x}(t|t) = & \int_0^t \int_0^{\sigma_1} \dots \int_0^{\sigma_{i-1}} \gamma_1(\sigma_1) \dots \gamma_i(\sigma_i) \\ & \cdot E^t [e^{\xi_\ell(t)} \xi_{k_1}(\sigma_1) \dots \xi_{k_i}(\sigma_i)] d\sigma_1 \dots d\sigma_i \end{aligned} \quad (D.16)$$

By equation (D.1) and the definition of the characteristic function, it follows that

$$\begin{aligned} & E^t [e^{\xi_\ell(t)} \xi_{k_1}(\sigma_1) \dots \xi_{k_i}(\sigma_i)] \\ & = e^{\hat{\xi}_\ell(t|t) + \frac{1}{2} P_{\ell\ell}(t) \{\delta_1(\sigma_1) \dots \delta_i(\sigma_i) \\ & \quad + \sum P_{j_1 j_2}(\sigma_{m_1}, \sigma_{m_2}, t) \delta_{j_3}(\sigma_{m_3}) \dots \delta_{j_i}(\sigma_{m_i}) + \dots\}} \end{aligned} \quad (D.17)$$

where

$$\delta_{j_\alpha}(\sigma_{m_\alpha}) = \hat{\xi}_{j_\alpha}(\sigma_{m_\alpha}|t) + P_{\ell, j_\alpha}(t, \sigma_{m_\alpha}, t) \quad (D.18)$$

and  $\{j_\alpha, \alpha = 1, \dots, i\}$  is a permutation of  $\{k_\alpha, \alpha = 1, \dots, i\}$ .

Equation (D.3) implies that (D.17) can be rewritten as

$$\begin{aligned}
& E^t [e^{\xi_\ell(t)} \xi_{k_1}(\sigma_1) \dots \xi_{k_i}(\sigma_i)] \\
&= e^{\hat{\xi}_\ell(t|t) + \frac{1}{2} P_{\ell\ell}(t)} \{E^t[\xi_{k_1}(\sigma_1) \dots \xi_{k_i}(\sigma_i)] \\
&\quad + \sum P_{\ell, j_1}(t, \sigma_{m_1}, t) E^t[\xi_{j_2}(\sigma_{m_2}) \dots \xi_{j_i}(\sigma_{m_i})] \\
&\quad + \sum P_{\ell, j_1}(t, \sigma_{m_1}, t) P_{\ell, j_2}(t, \sigma_{m_2}, t) E^t[\xi_{j_3}(\sigma_{m_3}) \dots \xi_{j_i}(\sigma_{m_i})] \\
&\quad + \dots + \sum P_{\ell, k_1}(t, \sigma_1, t) \dots P_{\ell, k_i}(t, \sigma_i, t)\} \tag{D.19}
\end{aligned}$$

Hence, Lemmas D.2 and D.4 imply that the computation of  $\hat{x}(t|t)$  involves only the computation of elements in  $\hat{\Lambda}_j$ ,  $j=1, \dots, i$ . However, the induction hypothesis implies that the elements of  $\hat{\Lambda}_j$ ,  $j=1, \dots, i-1$  are FDC, so we need only prove that the elements of  $\hat{\Lambda}_i$  are FDC.

ii) Assume that  $\eta \in \Lambda_i$  is defined by (D.14) (where  $j=i$ ). Then the nonlinear filtering equation (1.7)-(1.8) for  $\hat{\eta}(t|t)$  is

$$\begin{aligned}
d\hat{\eta}(t|t) &= E^t[\gamma_1(t) \xi_{k_1}(t) \lambda(t)] \\
&\quad + \{E^t[\eta(t) \xi'(t)] - \hat{\eta}(t|t) \hat{\xi}'(t|t)\} H'(t) R^{-1}(t) dv(t) \tag{D.20}
\end{aligned}$$

where

$$dv(t) = dz(t) - H(t) \hat{\xi}(t|t) dt \tag{D.21}$$

and

$$\lambda(t) = \int_0^t \int_0^{\sigma_2} \dots \int_0^{\sigma_{i-1}} \gamma_2(\sigma_2) \dots \gamma_i(\sigma_i) \xi_{k_2}(\sigma_2) \dots \xi_{k_i}(\sigma_i) d\sigma_2 \dots d\sigma_i \tag{D.22}$$

is an element of  $\hat{\Lambda}_{i-1}$ ; thus, by the induction hypothesis  $\hat{\lambda}(t|t)$  is FDC.

The first term in (D.20) (the drift term) is (see (D.3a))

$$\begin{aligned}
E^t[\gamma_1(t)\xi_{k_1}(t)\lambda(t)] &= \gamma_1(t)\hat{\xi}_{k_1}(t|t)\hat{\lambda}(t|t) \\
&+ \gamma_1(t)E^t \left[ \sum_{\ell=2}^i \int_0^t \int_0^{\sigma_2} \cdots \int_0^{\sigma_{i-1}} P_{k_1, k_i}(t, \sigma_i, t) \gamma_2(\sigma_2) \cdots \gamma_i(\sigma_i) \right. \\
&\quad \left. \cdot \xi_{k_2} \cdots \xi_{k_{\ell-1}} \xi_{k_{\ell+1}} \cdots \xi_{k_i} d\sigma_2 \cdots d\sigma_i \right] \quad (D.23)
\end{aligned}$$

The first term in (D.23) is FDC by the induction hypothesis, and the second term, by Lemmas D.2 and D.4, is also FDC (i.e., it is an element of  $\hat{\Lambda}_{i-2}$ ).

Equation (D.3a) implies that the gain term in (D.20) is the row vector (here  $P_i(\sigma, t, t)$  denotes the  $i^{\text{th}}$  row of  $P(\sigma, t, t)$ )

$$\begin{aligned}
&E^t[\eta(t)\xi'(t)] - \hat{\eta}(t|t)\hat{\xi}'(t|t) \\
&= \sum_{\ell=1}^i E^t \left[ \int_0^t \int_0^{\sigma_1} \cdots \int_0^{\sigma_{i-1}} \gamma_1(\sigma_1) \cdots \gamma_i(\sigma_i) \right. \\
&\quad \left. \cdot \xi_{k_1}(\sigma_1) \cdots \xi_{k_{\ell-1}}(\sigma_{\ell-1}) \xi_{k_{\ell+1}}(\sigma_{\ell+1}) \cdots \xi_{k_i}(\sigma_i) P_{k_\ell}(\sigma_\ell, t, t) d\sigma_1 \cdots d\sigma_k \right] \quad (D.24)
\end{aligned}$$

each element of which, by Lemmas D.2 and D.4, is an element of  $\hat{\Lambda}_{i-1}$ . Thus, by the induction hypothesis, the gain term, and hence the nonlinear equation (D.20) for  $\hat{\eta}(t|t)$  is FDC. This completes the proof of Theorem 5.1. ■



Proof of Theorem 5.2: This proof is identical to the proof of Theorem 5.1, except for the computation of the drift term in (D.20), so we will consider only that aspect of the proof. Assume that  $\eta$  is defined as in (5.9)--i.e.,  $\eta$  is given by

$$\eta(t) = \int_0^t \int_0^{\sigma_1} \dots \int_0^{\sigma_{j-1}} \xi_{k_1}(\sigma_{m_1}) \dots \xi_{k_i}(\sigma_{m_i}) \gamma_1(\sigma_1) \dots \gamma_j(\sigma_j) d\sigma_1 \dots d\sigma_j \quad (\text{D.25})$$

where  $i > j$ ; we also assume that  $m_1 = \dots = m_\alpha = 1$  and  $m_\beta \neq 1$  for  $\beta > \alpha$ . In this proof, the induction is on  $j$ , the number of integrals in (D.25). That is, we assume that the theorem is true when  $\eta$  contains  $\leq j-1$  integrals, and prove that the theorem holds if  $\eta$  contains  $j$  integrals.

The nonlinear filtering equation yields

$$\begin{aligned} d\hat{\eta}(t|t) = & E^t[\gamma_1(\sigma_1) \xi_{k_1}(t) \dots \xi_{k_\alpha}(t) \lambda(t)] \\ & + \{E^t[\eta(t) \xi'(t)] - \hat{\eta}(t|t) \hat{\xi}'(t|t)\} H'(t) R^{-1}(t) dv(t) \end{aligned} \quad (\text{D.26})$$

where  $dv$  is defined in (D.21) and

$$\lambda(t) = \int_0^t \int_0^{\sigma_2} \dots \int_0^{\sigma_{j-1}} \gamma_2(\sigma_2) \dots \gamma_j(\sigma_j) \xi_{k_{\alpha+1}}(\sigma_{m_{\alpha+1}}) \dots \xi_{k_i}(\sigma_{m_i}) d\sigma_2 \dots d\sigma_j \quad (\text{D.27})$$

The drift term in (D.26) is, from (D.3b),

$$\begin{aligned}
& E^t[\gamma_1(t)\xi_{k_1}(t)\dots\xi_{k_\alpha}(t)\lambda(t)] \\
& = \gamma_1(t)E^t[\xi_{k_1}(t)\dots\xi_{k_\alpha}(t)]\hat{\lambda}(t|t) \\
& + \gamma_1(t) \sum \{E^t[\xi_{l_2}(t)\dots\xi_{l_\alpha}(t)] \\
& \quad \cdot E^t[\int_0^t \int_0^{\sigma_2} \dots \int_0^{\sigma_{j-1}} \gamma_2(\sigma_2)\dots\gamma_j(\sigma_j)P_{l_1 l_{\alpha+1}}(t, \sigma_{\alpha+1}, t) \\
& \quad \cdot \xi_{l_{\alpha+2}}(\sigma_{\alpha+2})\dots\xi_{l_i}(\sigma_{m_i})d\sigma_2\dots d\sigma_j] + \dots
\end{aligned} \tag{D.28}$$

where  $\{l_1, \dots, l_\alpha\}$  is a permutation of  $\{k_1, \dots, k_\alpha\}$  and  $\{l_{\alpha+1}, \dots, l_i\}$  is a permutation of  $\{k_{\alpha+1}, \dots, k_i\}$ . The first term of (D.28) is FDC by the induction hypothesis, and the other terms, by Lemmas D.2 and D.4 and the induction hypothesis, are also FDC. We have also used the fact that the conditional distribution of  $\xi(t)$  given  $z^t$  is Gaussian (Lemma 5.1) in order to conclude that  $E^t[\xi_{k_1}(t)\dots\xi_{k_\alpha}(t)]$  can be computed (via (D.3c)) as a memoryless function of  $\hat{\xi}(t|t)$  and  $P(t)$ .

The gain term in (D.26) is also FDC; the proof is identical to that of Theorem 5.1. Hence  $\hat{\eta}(t|t)$  is FDC, and Theorem 5.2 is proved. ■

## BIBLIOGRAPHY

- A1. L. Auslander, "An Exposition of the Structure of Solvmanifolds," Bull. of Amer. Math. Soc., Vol. 79, No. 2, March 1973, pp. 227-285.
- A2. L. Auslander and R.E. Mac Kenzie, Introduction to Differentiable Manifolds. New York: McGraw-Hill, 1963.
- B1. R.W. Brockett, "System Theory on Group Manifolds and Coset Spaces," SIAM J. Control, Vol. 10, No. 2, May 1972, pp. 265-284.
- B2. R.W. Brockett, "On the Algebraic Structure of Bilinear Systems," in Theory and Applications of Variable Structure Systems, R. Mohler and A. Ruberti, eds., Academic Press, New York, 1972.
- B3. R.W. Brockett, "Lie Algebras and Lie Groups in Control Theory," in Geometric Methods in System Theory, D.Q. Mayne and R.W. Brockett, eds., Reidel Publ. Co., The Netherlands, 1973.
- B4. R.W. Brockett, "Lie Theory and Control Systems on Spheres," SIAM J. Appl. Math., Vol. 25, No. 2, Sept., 1973, pp. 213-225.
- B5. C. Bruni, G. DiPillo, and G. Koch, "Bilinear Systems: An Appealing Class of 'Nearly Linear' Systems in Theory and Applications," IEEE Trans. on Aut. Control, Vol. AC-19, No. 4, Aug. 1974, pp. 334-348.
- B6. G.L. Blankenship, "Perturbation Theory for Stochastic Ordinary Differential Equations with Applications to Optical Waveguide Analysis," Monograph of the Colloquium on the Application of Lie Group Theory to Nonlinear Network Problems, April 1974, IEEE Pub. No. 74 CHO 917-5 CAS.
- B7. G.L. Blankenship, Stability of Uncertain Systems, Ph.D. Thesis, Dept. of Electrical Engineering, M.I.T., Cambridge, Mass., June 1971.
- B8. R.W. Brockett, Finite Dimensional Linear Systems. New York: John Wiley, 1970.
- B9. R.S. Bucy, C. Hecht, and K.D. Senne, "New Methods for Nonlinear Filtering," Revue Francaise d'Automatique, Informatique et de Recherche Operationnelle, February 1973, pp. 3-54.
- B10. J.E. Bortz, "A New Mathematical Formulation for Strapdown Inertial Navigation," IEEE Trans. Aero. and Elec. Systems, Vol. AES-7, No. 1, January 1971, pp. 61-66.

- B11. R.W. Brockett and H.J. Sussman, "Tangent Bundles of Homogeneous Spaces are Homogeneous Spaces," Proc. Amer. Math. Soc., Vol. 35, No. 2, October 1972, pp. 550-551.
- B12. R.W. Brockett and J.R. Wood, "Electrical Networks Containing Controlled Switches," Monograph of the Colloquium on the Application of Lie Group Theory to Nonlinear Network Problems, April 1974, IEEE Pub. No. 74 CHO 917-5 CAS.
- B13. R. Bellman, Introduction to Matrix Analysis. New York: McGraw-Hill, 1970.
- B14. R.S. Bucy and H. Youssef, "Nonlinear Filter Representation Via Spline Functions," Fifth Symposium on Nonlinear Estimation and Its Applications, San Diego, Calif., September 23-25, 1974.
- B15. I.Y. Bar-Itzhack, "Optimum Normalization of a Computed Quaternion of Rotation," IEEE Trans. Aero. and Elec. Systems, Vol. AES-7, March 1971, pp. 401-402.
- B16. I.Y. Bar-Itzhack and K.A. Fegley, "Orthogonalization Techniques of a Direction Cosine Matrix," IEEE Trans. Aero. and Elec. Systems, Vol. AES-5, No. 5, September 1969, pp. 798-804.
- B17. R.W. Brockett, "Path Integrals, Liapunov Functions, and Quadratic Minimization," in Proc. 4th Allerton Conf. Circuit and System Theory, 1966, pp. 685-697.
- B18. A.E. Bryson, Jr. and W. Kortum, "Estimation of the Local Attitude of Orbiting Spacecraft," Automatica, Vol. 7, 1971, pp. 163-180.
- B19. R.S. Bucy and H. Youssef, "Fourier Realization of the Optimal Phase Demodulator," Fourth Symposium on Nonlinear Estimation and Its Applications, San Diego, Calif., 1973.
- B20. J.G.F. Belinfante and B. Kolman, A Survey of Lie Groups and Lie Algebras. Philadelphia: SIAM, 1972.
- B21. I.Y. Bar-Itzhack, "Iterative Optimal Orthogonalization of the Strapdown Matrix," IEEE Trans. Aero. and Elec. Systems, Vol. AES-11, January 1975, pp. 30-37.
- B22. R. Burrige, G.C. Papanicolaou, and D. McLaughlin, "The Solution by Descent of Certain Partial Differential Equations on the Sphere and Lobachevsky Plane," Comm. Pure Appl. Math., Vol. XXVI, 1973, pp. 105-129.
- B23. H. Boerner, Representations of Groups. Amsterdam: North-Holland Publ. Co., 1963.

- B24. R. Bivins, N. Metropolis, M. Rotenberg, and J.K. Wooten, The 3-j and 6-j Symbols. Cambridge, Mass.: M.I.T. Press, 1959.
- B25. R.W. Brockett, "Volterra Series and Geometric Control Theory," Triennial World Congress of IFAC, Cambridge, Mass., August 24-30, 1975.
- B26. G.L. Blankenship, "Lie Theory and the Moment Stability Problem in Stochastic Differential Equations," Triennial World Congress of IFAC, Cambridge, Mass., August 24-30, 1975.
- B27. R.W. Brockett, personal communication.
- C1. J.L. Center, "Practical Nonlinear Filtering of Discrete Observations by Generalized Least Squares Approximation of the Conditional Probability Distribution," Second Symposium on Nonlinear Estimation and Its Applications, San Diego, Calif., September 13-15, 1971.
- C2. C.T. Chen, Introduction to Linear System Theory. New York: Holt, Rinehart, and Winston, 1970.
- C3. C. Chevalley, Theory of Lie Groups. Princeton: Princeton University Press, 1946.
- C4. D.G. Carta and D.H. Lackowski, "Estimation of Orthogonal Transformations in Strapdown Inertial Navigation Systems," IEEE Trans. Aut. Control, Vol. AC-17, February 1972, pp. 97-100.
- C5. J.M.C. Clark, "An Introduction to Stochastic Differential Equations on Manifolds," in Geometric Methods in System Theory, D.Q. Mayne and R.W. Brockett, eds., Reidel Pub. Co., The Netherlands, 1973.
- D1. C.A. Desoer, et al., Monograph of the Colloquium on the Application of Lie Group Theory to Nonlinear Network Problems, IEEE Pub. No. 74 CHO 917-5 CAS.
- D2. T.E. Duncan, Probability Densities for Diffusion Processes with Applications to Nonlinear Filtering Theory and Detection Theory, TR. No. 7001-4, Stanford Electronics Lab., Stanford University, Stanford, Calif., May 1967.
- D3. R. Dennemeyer, Introduction to Partial Differential Equations and Boundary Value Problems. New York: McGraw-Hill, 1968.
- D4. C.F. Dunkl and D.E. Ramirez, Topics in Harmonic Analysis. New York: Appleton-Century-Crofts, 1971.
- D5. E.B. Dynkin and A.L. Oniscik, "Compact Global Lie Groups," AMS Translations, Series 2, Vol. 21, 1962, pp. 119-192.

- E1. A. Erdelyi, W. Magnus, F. Oberhettinger, and F. Tricomi, Higher Transcendental Functions, Vol. II. New York: McGraw-Hill, 1953.
- E2. D.L. Elliott, Controllable Nonlinear Systems Driven by White Noise, Ph.D. Dissertation, Univ. of Calif., Los Angeles, 1969.
- E3. D.L. Elliott, "Diffusions on Manifolds Arising from Controllable Systems," in Geometric Methods in System Theory, D.Q. Mayne and R.W. Brockett, eds., Reidel Pub. Co., The Netherlands, 1973.
- E4. B. Etkin, Dynamics of Atmospheric Flight. New York, John Wiley, 1972.
- F1. M. Fujisaki, G. Kallianpur, and H. Kunita, "Stochastic Differential Equations for the Nonlinear Filtering Problem," Osaka J. Math., Vol. 9, 1972, pp. 19-40.
- F2. R. Fischl and J.P. McIlvaine, "Effect of Observation Errors on Satellite Attitude Estimation," IEEE Trans. Aero. and Elec. Systems, Vol. AES-8, January 1972, pp. 81-84.
- F3. A.M. Frew, D.K. Kirby, P.C. Wheeler, and T.C. Huber, "An Integrated System for Precision Attitude Determination and Control," AIAA Guidance, Control, and Flight Mechanics Conference, Hempstead, N.Y., August 16-18, 1971.
- G1. M. Gruber, Stability Analysis Using Exact Differentials, Ph.D. Thesis, Dept. of Electrical Engineering. M.I.T., Cambridge, Mass. 1968.
- G2. D.E. Gustafson and J.L. Speyer, "Linear and Asymptotic Minimum Variance Filters Applied to Phase-Lock Loops," IEEE Trans. Aut. Control, to appear.
- G3. C.R. Giardina, "Comments on 'Optimum Normalization of a Computed Quaternion of Rotation,'" IEEE Trans. Aero. and Elec. Systems, Vol. AES-10, May 1974, pp. 392-393.
- G4. U. Grenander, Probabilities on Algebraic Structures. New York: John Wiley, 1963.
- G5. R. Gilmore, Lie Groups, Lie Algebras, and Some of Their Applications. New York: John Wiley, 1974.
- G6. W.H. Greub, Multilinear Algebra. New York: John Wiley, 1967.
- G7. F.R. Gantmacher, The Theory of Matrices, Vol. I. New York: Chelsea, 1960.
- G8. A. Gelb, ed., Applied Optimal Estimation. Cambridge, Mass.: M.I.T. Press, 1974.

- H1. R.M. Hirschorn, "Controllability in Nonlinear Systems," in Geometric Methods in System Theory, D.Q. Mayne and R.W. Brockett, Eds., Reidel Pub. Co., The Netherlands, 1973.
- H2. R.M. Hirschorn, "Control of Bilinear Systems," Monograph of the Colloquium on the Application of Lie Group Theory to Nonlinear Network Problems, April 1974, IEEE Pub. No. 74 CHO 917-5 CAS.
- H3. S. Helgason, Differential Geometry and Symmetric Spaces. New York: Academic Press, 1962.
- H4. E. Hewitt and K.A. Ross, Abstract Harmonic Analysis. New York: Springer-Verlag, 1970.
- H5. M. Hamermesh, Group Theory and Its Application to Physical Problems. Reading, Mass.: Addison-Wesley, 1962.
- H6. H. Harari, "On the Reduction of Direct Products of the Irreducible Representations of  $SU(n)$ ," J. Math. Phys., Vol. 7, February 1966, p. 283.
- I1. A. Isidori and A. Ruberti, "Realization Theory of Bilinear Systems," in Geometric Methods in System Theory, D.Q. Mayne and R.W. Brockett, eds., Reidel Pub. Co., The Netherlands, 1973.
- I2. S. Ito, "Fundamental Solutions of Parabolic Differential Equations," Jap. J. Math., Vol. 27, 1957, pp. 55-102.
- I3. K. Ito, "Stochastic Differential Equations in a Differentiable Manifold," Nagoya Math. J., Vol. 1, 1950, pp. 35-47.
- I4. R.P. Iwens and R.L. Farrenkopf, "Performance Evaluation of a Precision Attitude Determination System (PADS)," AIAA Guidance, Control, and Flight Mechanics Conference, Hempstead, New York, August 16-18, 1971.
- J1. A.H. Jazwinski, Stochastic Processes and Filtering Theory. New York: Academic Press, 1970.
- J2. C. Johnson and E.B. Stear, "Optimal Filtering in the Presence of Multiplicative Noise," Fifth Symp. on Nonlinear Estimation and Its Applications, San Diego, Calif., September 23-25, 1974.
- J3. V. Jurdjevic and H.J. Sussman, "Control Systems on Lie Groups," J. Diff. Eqns., Vol. 12, No. 2, 1972, pp. 313-329.
- J4. N. Jacobson, Lie Algebras. New York: Interscience, 1962.
- J5. A. Joseph, "Self-Adjoint Ladder Operators. III." Rev. Mod. Phys., Vol. 40, October 1968, pp. 845-871.

- K1. R.E. Kalman and R.S. Bucy, "New Results in Linear Filtering and Prediction Theory," J. Basic. Engr. (Trans. ASME), Vol. 83D, 1961, pp. 95-108.
- K2. H.J. Kushner, "Dynamical Equations for Optimal Nonlinear Filtering," J. Diff. Eqn., Vol. 3, 1967, pp. 179-190.
- K3. G. Koch, "Stochastic Bilinear Systems: Modeling and Identification," Inst. Automatica, Univ. of Rome, Rome, Italy, Rep. 2-06, April 1972.
- K4. G. Koch, "Volterra Series Expansion for Stochastic Bilinear Systems," Inst. Automatica, Univ. of Rome, Rome, Italy, Rep. 2-07, April 1972.
- K5. G. Koch, "Some Results on Stochastic Bilinear Systems," Fourth Symposium on Nonlinear Estimation and Its Applications, San Diego, Calif., September 10-12, 1973.
- K6. A.J. Krener, "On the Equivalence of Control Systems and Linearization of Nonlinear Systems," SIAM J. Control, Vol. 11, 1973, pp. 670-676.
- K7. A.J. Krener, "Bilinear and Nonlinear Realizations of Input-Output Maps," SIAM J. Control, to appear.
- K8. A.J. Krener, "Linearization and Bilinearization of Control Systems," 12th Allerton Conf. Circuit and System Theory, October 1974.
- K9. A.J. Krener, "Local Approximation of Control Systems," J. Diff. Eqn., to appear.
- K10. R.E. Kalman, "Linear Stochastic Filtering Theory--Reappraisal and Outlook," Symposium on System Theory, Poly. Inst. of Brooklyn, April 20-22, 1965.
- K11. H. Kwakernaak, "Optimal Filtering in Linear Systems with Time Delays," IEEE Trans. on Aut. Control, Vol. AC-12, 1967, pp. 169-173.
- K12. T. Kailath and P. Frost, "An Innovations Approach to Least-Squares Estimation, Part II: Linear Smoothing in Additive White Noise," IEEE Trans. on Aut. Control, Vol. AC-13, December 1968, pp. 655-660.
- L1. B.W. Licht, Approximations in Optimal Nonlinear Filtering, Ph.D. Thesis, Systems Research Center, Case Western Reserve Univ., Cleveland, Ohio, April 1970.
- L2. J.T. Lo and A.S. Willsky, "Estimation for Rotational Processes with One Degree of Freedom I: Introduction and Continuous Time Processes," IEEE Trans. on Aut. Cont., Vol. AC-20, No. 1, February 1975, pp. 10-21.



- L3. J.T. Lo and A.S. Willsky, "Stochastic Control of Rotational Processes with One Degree of Freedom," SIAM J. Control, Vol. 13, No. 4, November 1975.
- L4. J.T. Lo, "Signal Detection on Lie Groups," in Geometric Methods in System Theory, D.Q. Mayne and R.W. Brockett, eds., Reidel Publ Co., The Netherlands, 1973.
- L5. J.T. Lo, "Bilinear Stochastic Systems and Finite Dimensional Sensor Orbits," Eighth Princeton Conference on Information Sciences and Systems, Princeton, New Jersey, March 28-29, 1974.
- L6. J.S. Lee and F.F. Tung, "Nonlinear Filtering Techniques with Application to Strapdown Computation," IEEE Trans. on Aut. Control, Vol. AC-15, No. 1, February 1970, pp. 74-80.
- L7. L.H. Loomis, An Introduction to Abstract Harmonic Analysis. Princeton: Van Nostrand, 1953.
- L8. J.T. Lo, "Signal Detection of Rotational Processes and Frequency Demodulation," Inf. and Control, Vol. 26, 1974, pp. 99-115.
- L9. J.D. Louck, "Recent Progress Toward a Theory of Tensor Operators in the Unitary Groups," Amer. J. Physics, Vol. 38, January 1970, pp. 3-42.
- L10. C.T. Leondes, J.B. Peller, and E.B. Stear, "Nonlinear Smoothing Theory," IEEE Trans. Syst. Sci. Cyber., Vol. SSC-6, 1970, p. 63.
- M1. D.N. Martin, Stability Criteria for Systems with Colored Multiplicative Noise, Ph.D. Thesis, Dept. of Electrical Engineering, M.I.T., Cambridge, Mass., June 1974.
- M2. D.Q. Mayne and R.W. Brockett, eds., Geometric Methods in System Theory, Reidel Pub. Co., The Netherlands, 1973.
- M3. W. Miller, Lie Theory and Special Functions. New York: Academic Press, 1968.
- M4. W. Miller, "Some Applications of the Representation Theory of the Euclidean Group in Three-Space," Comm. Pure Appl. Math., Vol. XVII, 1964, pp. 527-540.
- M5. R. Mohler, "Bilinear Structures and Man," in Theory and Applications of Variable Structure Systems, R. Mohler and A. Ruberti, eds., Academic Press, New York, 1972.
- M6. R. Mohler, Bilinear Control Processes. New York: Academic Press, 1973.

- M7. H.P. McKean, Jr., Stochastic Integrals. New York: Academic Press, 1969.
- M8. H.P. McKean, Jr., "Brownian Motion on the 3-Dimensional Rotation Groups," Mem. Coll. Sci. Kyoto Univ., Vol. 33, 1960, pp. 25-38.
- M9. J.J. Mallinckrodt, R.S. Bucy, and S.Y. Chang, Final Project Report for a Design Study for an Optimal Non-Linear Receiver/Demodulator, NASA Contract NAS 5-10789, Goddard Space Flight Center, Maryland, 1970.
- M10. R.E. Mortensen, "Strapdown Guidance Error Analysis," IEEE Trans. Aero and Elec. Systems, Vol. AES-10, No. 4, July 1974, pp. 451-457.
- M11. K.S. Miller, Multidimensional Gaussian Distributions. New York: John Wiley, 1965.
- M12. D.N. Martin, S.I. Marcus, A.S. Willsky, and T.L. Johnson, "On the Stochastic Stability of Linear Systems Containing Colored Multiplicative Noise," submitted to IEEE Trans. on Aut. Control.
- M13. S. Minakshisundaram, "Eigenfunctions on Riemannian Manifolds," Ind. Math. Soc. Journal, Vol. 17, 1953, pp. 159-165.
- M14. P.J. McLane, "Optimal Linear Filtering for Linear Systems with State-Dependent Noise," Int. J. Control, Vol. 10, No. 1, July 1969.
- M15. R.K. Miller, Nonlinear Volterra Integral Equations. Menlo Park: Benjamin, 1971.
- M16. F.D. Murnaghan, Theory of Group Representations. Baltimore: Johns Hopkins Press, 1938.
- N1. T. Nakamizo, "On the State Estimation for Non-Linear Dynamic Systems," Int. J. Control, Vol. 11, No. 4, 1970, pp. 683-695.
- P1. J.E. Potter and W.E. Vander Velde, Optimum Mixing of Gyroscope and Star Tracker Data, Experimental Astronomy Lab. Report RE-26, M.I.T., Cambridge, Mass., 1967.
- P2. J.E. Potter and E.J. Frey, Rotation Invariant Probability Distributions on the Surface of a Sphere, with Applications to Geodesy, Experimental Astronomy Lab. Report RE-27, M.I.T., Cambridge, Mass., May 1967.
- P3. R.S. Palais, A Global Formulation of the Lie Theory of Transformation Groups, Mem. of the Amer. Math Soc., Vol. 22, 1957.
- P4. A. Papoulis, Probability, Random Variables, and Stochastic Processes. New York: McGraw-Hill, 1965.

- P5. R.S. Palais, "Imbedding of Compact, Differentiable Transformation Groups in Orthogonal Representations," J. Math. and Mech., Vol. 6, 1957, pp. 673-678.
- R1. T.J. Ryan, An Optimum Stellar Monitored Strapdown Navigation System, M.S. Thesis, Dept. of Aeronautics and Astronautics, M.I.T., Cambridge, Mass., 1968.
- R2. W. Rudin, Real and Complex Analysis. New York: McGraw-Hill, 1966.
- R3. I.B. Rhodes, "A Tutorial Introduction to Estimation and Filtering," IEEE Trans. on Aut. Control, Vol. AC-16, Dec. 1971, pp. 688-706.
- S1. A.A. Sagle and R.E. Walde, Introduction to Lie Groups and Lie Algebras. New York: Academic Press, 1973.
- S2. H. Samelson, Notes on Lie Algebras. New York: Van Nostrand, 1969.
- S3. L. Schwartz and E.B. Stear, "A Computational Comparison of Several Nonlinear Filters," IEEE Trans. on Aut. Control, Vol. AC-13, 1968, pp. 83-86.
- S4. B.W. Stuck, Space Satellite Dynamics with Applications to Sunlight Pressure Attitude Control, Ph.D. Thesis, Dept. of Electrical Engineering, M.I.T., Cambridge, Mass., June 1972.
- S5. B.W. Stuck, "A New Method for Attitude Estimation," presented at the AAS/AIAA Astrodynamics Conference, Vail, Colorado, July 16-18, 1973.
- S6. H.J. Sussman and V. Jurdjevic, "Controllability of Nonlinear Systems," J. Diff. Eqn., Vol. 12, No. 1, July 1972, pp. 95-116.
- S7. Y. Sunahara, Technical Report 67-8, Center for Dynamical Systems, Div. of Applied Math., Brown Univ., Providence, R.I., 1967.
- S8. E.M. Stein, Topics in Harmonic Analysis. Princeton: Princeton Univ. Press, 1970.
- S9. R. Steinberg, "A General Clebsch-Gordan Theorem," Bull. Amer. Math. Soc., Vol. 67, 1961, pp. 401-407.
- S10. L.M. Silverman and B.D.O. Anderson, "Controllability, Observability, and Stability of Linear Systems," SIAM J. Control, Vol. 6, 1968, pp. 121-130.
- S11. J.L. Sedwick, The Equivalence of Nonlinear and Bilinear Control Systems, Sc.D. Thesis, Sever Institute of Technology, Washington Univ., St. Louis, Mo., December 1974.

- S12. J.L. Sedwick and D.L. Elliott, "Nonlinear Systems Equivalent to Controllable Bilinear Systems," IEEE Conference on Decision and Control, Phoenix, Ariz., November 1974.
- S13. R.T. Seeley, "Spherical Harmonics," Amer. Math. Monthly, Vol. 73, 1966, pp. 115-121.
- T1. J.D. Talman, Special Functions -- A Group Theoretic Approach. New York: Benjamin, 1968.
- V1. N.J. Vilenkin, Special Functions and the Theory of Group Representations. Providence: American Math. Society, 1968.
- W1. J.C. Willems and G. Blankenship, "Frequency Domain Stability Criteria for Stochastic Systems," IEEE Trans. on Aut. Control, Vol. AC-16, August 1971, pp. 292-299.
- W2. A.S. Willsky, Dynamical Systems Defined on Groups: Structural Properties and Estimation, Ph.D. Thesis, Dept. of Aeronautics and Astronautics, M.I.T., Cambridge, Mass., June 1973.
- W3. A.S. Willsky and J.T. Lo, "Estimation for Rotational Processes with One Degree of Freedom, Parts II, III," IEEE Trans. on Aut. Control, Vol. AC-20, No. 1, February 1975, pp. 22-33.
- W4. A.S. Willsky, "Some Estimation Problems on Lie Groups," in Geometric Methods in System Theory, R.W. Brockett and D.Q. Mayne, eds., Reidel Publ Co., The Netherlands, 1973.
- W5. A.S. Willsky, "Estimation and Detection of Signals in Multiplicative Noise," submitted to IEEE Trans. on Aut. Control.
- W6. A.S. Willsky, "Fourier Series and Estimation on the Circle with Applications to Synchronous Communication, Parts I, II," IEEE Trans. on Inf. Theory, Vol. IT-20, No. 5, September 1974, pp. 577-590.
- W7. A.S. Willsky and S.I. Marcus, "Analysis of Bilinear Noise Models in Circuits and Devices," Monograph of the Colloquium on the Application of Lie Group Theory to Nonlinear Network Problems, April 1974, IEEE Pub. No. 74 CHO 917-5 CAS.
- W8. E. Wong, Stochastic Processes in Information and Dynamical Systems. New York: McGraw-Hill, 1971.
- W9. E. Wong and M. Zakai, "On the Relation Between Ordinary and Stochastic Differential Equations," Int. J. Engrg. Sci., Vol. 3, pp. 213-229.
- W10. E. Wong and M. Zakai, "On the Convergence of Ordinary Integrals to Stochastic Integrals," Ann. Math. Stat., Vol. 36, pp. 1560-1564.

- W11. F. Warner, Foundations of Differential Manifolds and Lie Groups. Glenview, Ill.: Scott, Foresman and Co., 1971.
- W12. A.S. Willsky and S.I. Marcus, Estimation for Bilinear Stochastic Systems, M.I.T. Electronic Systems Laboratory Report No. ESL-R-544, M.I.T., Cambridge, Mass., May 1974.
- W13. J.C. Wilcox, "A New Algorithm for Strapped-Down Inertial Navigation," IEEE Trans. Aero. and Elec. Systems, Vol. AES-7, No. 5, September 1967, pp. 796-802.
- W14. J. Wei and E. Norman, "Lie Algebraic Solution of Linear Differential Equations," J. Math. Phys., Vol. 4, 1963, pp. 575-581.
- W15. J. Wei and E. Norman, "On Global Representations of the Solutions of Linear Differential Equations as a Product of Exponentials," Proc. Amer. Math. Soc., Vol. 15, 1964, pp. 327-334.
- W16. R.P. Wishner, J.A. Tabaczynski, and M.A. Athans, "A Comparison of Three Nonlinear Filters," Automatica, Vol. 5, pp. 487-496.
- W17. W. Wrigley, W. Hollister, and W. Denhard, Gyroscopic Theory, Design and Instrumentation. Cambridge, Mass.: M.I.T. Press, 1969.
- W18. W.M. Wonham, "On a Matrix Riccati Equation of Stochastic Control," SIAM J. Control, Vol. 6, 1968, pp. 681-697.
- W19. E.P. Wigner, "Symmetry Principles in Old and New Physics," Bull. Amer. Math. Soc., Vol. 74, September 1968, pp. 793-815.
- W20. A.S. Willsky, personal communication.
- W21. J.L. Willems, "Stability Analysis of a Particular Class of Stochastic Systems," to appear.
- W22. J.L. Willems, "Stability of Higher Order Moments for Linear Stochastic Systems," to appear.
- W23. J.L. Willems, "Stability Criteria for Stochastic Systems with Colored Multiplicative Noise," to appear.
- Y1. K. Yosida, "Integration of Fokker-Planck's Equation in a Compact Riemannian Space," Arkiv for Matematik, Vol. 1, 1949, pp. 71-75.
- Y2. K. Yosida, "Brownian Motion on the Surface of the 3-Sphere," Ann. Math. Stat., Vol. 20, 1949, pp. 292-296.
- Y3. K. Yosida, "Brownian Motion in a Homogeneous Riemannian Space," Pacific J. Math., Vol. 2, 1952, pp. 263-270.

## BIOGRAPHICAL NOTE

Steven Irl Marcus was born in St. Louis, Missouri on April 2, 1949. He attended public schools in Dallas, Texas and graduated from Hillcrest High School in June, 1967. In September, 1967 he entered Rice University, Houston, Texas, graduating summa cum laude in June, 1971 with the B.A. degree in electrical engineering and mathematics.

Mr. Marcus has been a full-time graduate student in the Department of Electrical Engineering at M.I.T. since September, 1971. He has been supported by a National Science Foundation Fellowship from September, 1971 through August, 1974, by a teaching assistantship from September through December, 1974, and by a research assistantship from January, 1975 to the present time. He was awarded the degree of Master of Science in September, 1972. He has also been elected to Tau Beta Pi, Sigma Tau, and Sigma Xi.

During summers Mr. Marcus has been employed by LTV Aerospace Corporation (1968), Collins Radio Company (1969), and The Analytic Sciences Corporation (1973).