

A SYSTEM DESIGN FOR A COURTHOUSE BUILDING IN BOSTON: Implementing User Needs and Requirements

by Edgar Alexander Quiroz
Bachelor of Science in Architecture., Catholic University of America
Washington D.C.
May 1989

SUBMITTED TO THE DEPARTMENT OF ARCHITECTURE IN PARTIAL
FULFILLMENT OF THE REQUIREMENTS FOR THE DEGREE
MASTER OF ARCHITECTURE AT THE
MASSACHUSETTS INSTITUTE OF TECHNOLOGY
JUNE 1992

@ Edgar Alexander Quiroz 1992. All rights reserved.

The author hereby grants to M.I.T. permission to reproduce and to distribute
publically copies of this thesis document in whole or in parts

Signature of the Author

Edgar A. Quiroz
April 8, 1992

Certified by

Eric Dluhosch
Associate Professor of Building Technology
Thesis Supervisor

Accepted by

John R. Myer
Chairman, Departmental Committee on Graduate Studies

Rotc

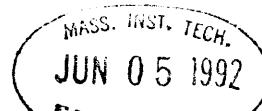



Room 14-0551
77 Massachusetts Avenue
Cambridge, MA 02139
Ph: 617.253.2800
Email: docs@mit.edu
<http://libraries.mit.edu/docs>

DISCLAIMER OF QUALITY

Due to the condition of the original material, there are unavoidable flaws in this reproduction. We have made every effort possible to provide you with the best copy available. If you are dissatisfied with this product and find it unusable, please contact Document Services as soon as possible.

Thank you.

The images contained in this document are of the best quality available.

for my parents

Acknowledgements

I would like to mention my indebtedness to my family and my gratitude to the following persons: Thomas Chastain, Renee Chow, Imre Halasz, Frank Miller, William Porter, and Maurice Smith. This thesis would not have been possible without the encouragement and patient guidance of Dr. Eric Dluhosch. His thorough knowledge of building systems helped me develop and structure my own ideas. My deepest respect and appreciation go to him.

A SYSTEM DESIGN FOR A COURTHOUSE BUILDING IN BOSTON: Implementing User Needs and Requirements

Edgar A. Quiroz

Submitted to the Department of Architecture on June 8, 1992, in partial fulfillment of the requirements for the degree of Master of Architecture.

Abstract

In this thesis, I will design a courthouse building located in the Government Center, Boston. This investigation will eventually lead to the development of a preliminary building system. In order to arrive at this level of investigation, urban issues and internal building organizational issues pertaining to user needs and requirements will both shape the preliminary overall building configuration. Once that configuration is established, I will focus on a specific portion of the overall building to develop a preliminary courthouse building system.

I will use the observations and design principles of Herman Hertzberger to aid me in resolving some user needs and requirements when investigating urban as well as internal building organizational issues. Along with a building system methodology throughout the design process, what should result is an efficient courthouse building with a more habitable environment for its users.

The thesis is composed of five parts:

- Section One introduces the premises for this inquiry. It discusses the use of a system design methodology and recommends the implementation of user needs and requirements at an early design stage.
- Section Two outlines the interrelationships within urban organization where built form and exterior space coexist.
- Section Three describes the organization of the interior spaces: with respect to access movement, the relationship of discrete spaces transformed into separate and distinct use zones.
- Section Four presents a design system for the construction of the courthouse building. This section will show the systematic progression of a design system for a small portion of the courthouse building.
- Section Five demonstrates the position coordination of the building elements in relation to a modular tartan band grid.
- Section Six outlines the conclusion

Thesis Supervisor

Eric Dluhosch
Associate Professor of Building Technology

Content

Title Page	i
Acknowledgements	iv
Abstract	v
Content	vii
Foreword	1
Section 1. Introduction	3
1.1 Design Methodology.	3
1.2 User as Contributors to Effective Design.	5
1.3 User/Designer Partnership.	6
Section 2. The Relationship of the Courthouse Building to the Urban Landscape	8
2.1 Site Information	10
2.2 Site Analysis	20
2.3 Site Access Criteria	23
2.4 Street Use	24
2.5 Private and Public Spatial Use	27
2.6 Urban Dimensional Stabilities	30
2.7 Indoor and Outdoor Use Exchange	36
2.8 Threshold	38
Section 3. Internal Spatial Organization of the Courthouse Building.	40
3.1 Access Zones of Exchange	42
3.1.1 Vertical Zones of Exchange	45
3.1.2 Horizontal Zones of Exchange	47
3.2 Courthouse Spatial Uses	50
3.2.1 Use Plan Layouts	50

Section 4. Building System Analysis	52
4.1 Structural Elements	60
4.2 Catalog of Parts	66
4.3 Beams	66
4.3.1 Primary Beams	66
4.3.2 Secondary Beams	70
4.4 Columns	76
4.4.1 Primary Columns	76
4.4.2 Secondary Columns	76
4.5 Partitions	80
4.6 Cladding	84
4.7 Floor Elements	88
4.8 Assembly Sequence	92
Section 5. Positional Coordination	94
5.1 The Tartan Band Grid	94
5.2 Components within Tartan Band Grid.	95
5.2.1 Secondary Partitions and Enclosure.	95
5.2.2 Location of Primary Partitions.	95
5.2.3 Location of Primary Structure.	95
5.2.4 Location of Secondary Structure	95
5.3 Dimensions of Structural Components	96
5.4 Components located within Bands	96
5.5 Nominal Dimensions	97
5.6 The Vertical Plane	98
5.6.1 Positioning of Columns	98
5.6.2 Positioning of Partitions	99
5.7 Basic Courtroom Plan Determinants	100
5.7.1 Structural	100
5.7.2 Dimensional	100
5.8 Relationship of Structural Elements to Basic Courtroom Plan	101
5.9 Flexibility and Variability of Courtroom Within Modular Grid	102

Section 6. Conclusion	107
Appendices	
Program of Courthouse	108
Final Model Illustrations	116
Credit for Illustrations	124
Bibliography	126

Foreword

What makes a building design successful? What steps should the architect take in the design process to achieve a well-designed building? What inherent characteristics should a building have in order to be characterized as well-designed? These questions encouraged me to pursue their conceptual roots in my academic coursework.

This thesis is an attempt to create a well-designed building using a systematic design methodology. Additionally, this thesis will attempt to prove that the use of a methodology as a viable design process achieves a greater degree of both user satisfaction and formal clarity in the final design of a courthouse building.

Section 1. Introduction

1.1 Design Methodology

A design methodology is a way of structuring the architect's design intentions, thus insuring logical results that are considered at the appropriate time together with the proper reasoning about them. All projects have objectives delineated by the creative mind determining them. These objectives are often expressed in a set of abstract functions that are a result of predetermined set of rules. These rules in turn reduce the range of options, informing the architect to include only those options which are compatible with the program.

One characteristic of these functions is their abstract nature which cannot be measured quantitatively. Project functions supported by various processes serve as the foundation of the whole project. Furthermore, these processes are related to the assembly of elements. Processes and elements can be measured and sized. The aggregate of all these parts can be graphically represented as a pyramid, exemplifying a logical process. (fig 1.1.)

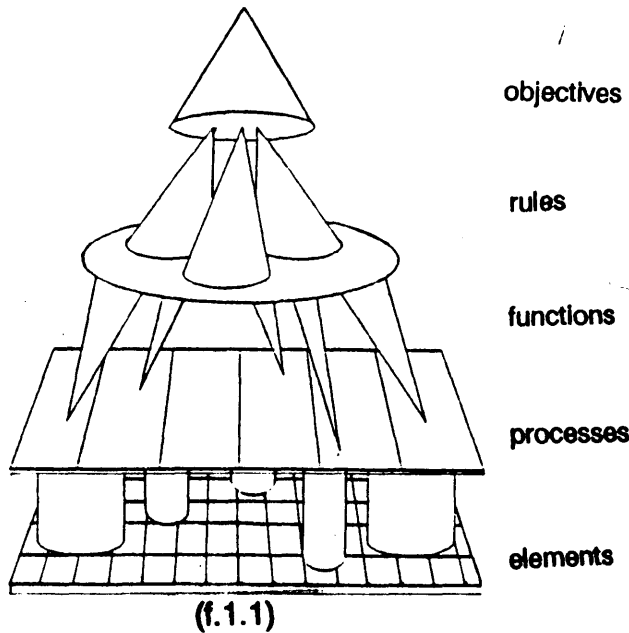

A design methodology is the designer's approach in envisioning the abstract objectives of the project. This method provides a way for the designer to study, analyze, and determine limits, boundaries, and parameters. The upper level of the pyramid represents the goals, objectives, and functions of the design. A design methodology is the systematic approach to design in which it is necessary to consider all the levels and interconnections among the parts of the project. Constant evaluation throughout the pyramid is necessary for a successful design methodology. Such evaluation insures that any action on any level of the pyramid does not produce undesirable results. A design methodology provides a framework which leads towards the achievement of specific objectives.

These objectives can be considered as user determined design solutions, and are achieved when:

- project goals are constantly kept in mind by the designer during the design process;
- an open attitude towards user requests and refinements of program goals and objectives are maintained by the designer;
- the system designer selects a set of ordering principles and procedures for consideration in his design methodology. He should exclude requirements that he considers unfit for application within the terms of the program;
- the designer maintains tolerance, or an attitude of objectivity towards alternative design options, which can provide the elaboration of a system development;
- the structural system is kept as technically "open" as possible to accommodate the greatest possible range of plan options;
- a process should be implemented to provide a convenient and frequent means to monitor the evolution of a building system's development. Documentation produced by this system should be carefully analyzed during the life-cycle of the design, by both user and designer. Refinements to the design, if necessary, should be executed by both parties until complete satisfaction is achieved.

The designers should ask themselves questions such as the following: "Under what conditions is it sensible to attempt these objectives?" And, "do these conditions apply to the area of concern?" These questions should be asked frequently and should be positively answered. Herman Hertzberger stated the following:

*"Every well-designed building has a consistent idea with a distinct thematic unity behind it, a unity of vocabulary, material, and building method. But here the essential thing is design based on a consistent strategy. Starting out from the components you have to go through the whole building again and again to check where are all the extremities of a common theme (hence putting the hypothesis to the test). That exploration in turn leads to adjustments to the hypothesis or theme."*¹

1.2 User as Contributor to Effective Design

A user becomes a dweller when the design of a dwelling meets the user's requirements. When the final product is accepted and praised by its users, we say that the product is a well-designed building. In contemporary society, user opinions are already being accepted as a determining factor for rating a consumer product (here, we may include buildings and dwellings as products as well). These opinions are also critical for future building designs. If user opinions are considered at the early conceptual stages of design, there exists a greater probability that a future structure will meet user approval, thereby allowing for greater longevity for the structure.

A user may move to different buildings, or commission customized structures because he or she outgrew old structures, or the old structures did not meet new user physical needs. A user seeks out an environment where the surroundings give him or her greater satisfaction than merely serving as enclosure for daily work or as nightly shelter. Users have become more demanding in their daily activities and requirements. Due to

¹ Herman Hertzberger, 'Lessons For Students in Architecture', Uitgeverij 010 Publishers, Rotterdam, 1989, p.144.

the availability of more information and greater sophistication of today's society, a citizen has at his disposal many amenities and actively participates in the forces that govern communities. Many individuals are participating in the building industry and have taken more active roles in designing the structures in which they live.

1.3 User/Designer Partnership

The major problems associated with some designs are as follows;

- development cost vs. budget
- development timescales vs. planned timescales
- the production of form and spaces which do not meet the user's requirements (difficult to modify and correct).

Perhaps the major reason for problems experienced today by designers is the massive increase in size and complexity of developing buildings without any comparable change in design methodology. Many designers pursue their jobs with limited time devoted to user/designer interchange of ideas. It is vital to remove any potential and real errors from design at an early stage. It is also important to assume that user requirements will change as environments change. Maintenance problems and the likelihood of future modifications should be accounted for in the design. Architect Herman Hertzberger's comments on this subject:

*"The building order of a project is the outcome of a more profound realization of the uses to which it will be put, now and in the future. The building order thus anticipates the 'performance' that may presumably be expected of it."*²

² Herman Hertzberger, 'Lessons For Students in Architecture', Uitgeverij 010 Publishers, Rotterdam, p.144.

An early understanding of the roles between user and designer is mandatory. Users have the potential power to emancipate themselves from the designer's rigid conventions, consumerism, and professional whims. On the other hand, the designer contributes a professional knowledge of design and his imagination. His or her professional experiences should equip him or her with the ability to distinguish between legitimate collective needs or patterns and idiosyncratic subjective needs.

The final product resulting from a joint user/designer project should give the user complete satisfaction in using the building. In addition, the final design should contribute to preserving the user's identity. Herman Hertzberger emphatically states:

*'Architecture should offer an incentive to its users to influence it whenever possible, not to reinforce the identity of the forms, but to enhance and affirm the identity of its users.'*³

The cost and time of achieving acceptable user requirements must also correspond with the time taken to reach a specific, complete, and clear statement on the objectives of the project agreed upon by the user. The need for a structured design methodology is not solely based upon the solutions associated with current approaches. In addition, there exists a requirement in all areas of building design to improve the productivity of the design staff as well as the quality of the final product.

The design process does not follow a linear path. Frequent revisions of the project objectives between user contribution and designer refinement will make a more satisfying final product. Herman Hertzberger is a fervent proponent of constant refinements during the design process until perfection is reached. For him, a design is a product of taking heed or informing himself of constant observations by dwellers and building users. He has an acute sense of perception in translating user needs into spatial form.

³ Herman Hertzberger, 'Lessons For Students in Architecture', Uitgeverij 010 Publishers, Rotterdam, p.148.

Section 2: Site Analysis: The Relationship of the Courthouse Building to the Urban Landscape

*'These interrelationships of urban use generate a spacial organization in which built form and exterior space are not only complementary to each other in a spatial sense, but also permit maximal accessibility to penetrate each other. Not only do borderlines between indoor and outdoor become less explicit, but also the sharp division between private and public space is softened. If you enter a place gradually, the front entrance is divested of its significance as a single and abrupt moment; it is extended, as it were, into a threshold, forming a step-by-step sequence of spaces which are not yet explicitly indoor but also less explicitly outdoor.'*⁴

Some courthouses have been designed with high walls separating both visually and symbolically the wielders of power from the common citizen. These over-sized, impenetrable, castle-like structures clearly separate the off-limits areas from the public areas and the streets. A courthouse design should maintain a reasonable balance between the solemnity of its role as a courthouse and the surroundings.

⁴ Herman Hertzberger, *Buildings and Projects, 1959-1986* Denhagg, A. Lchinger, 1987,p.9.

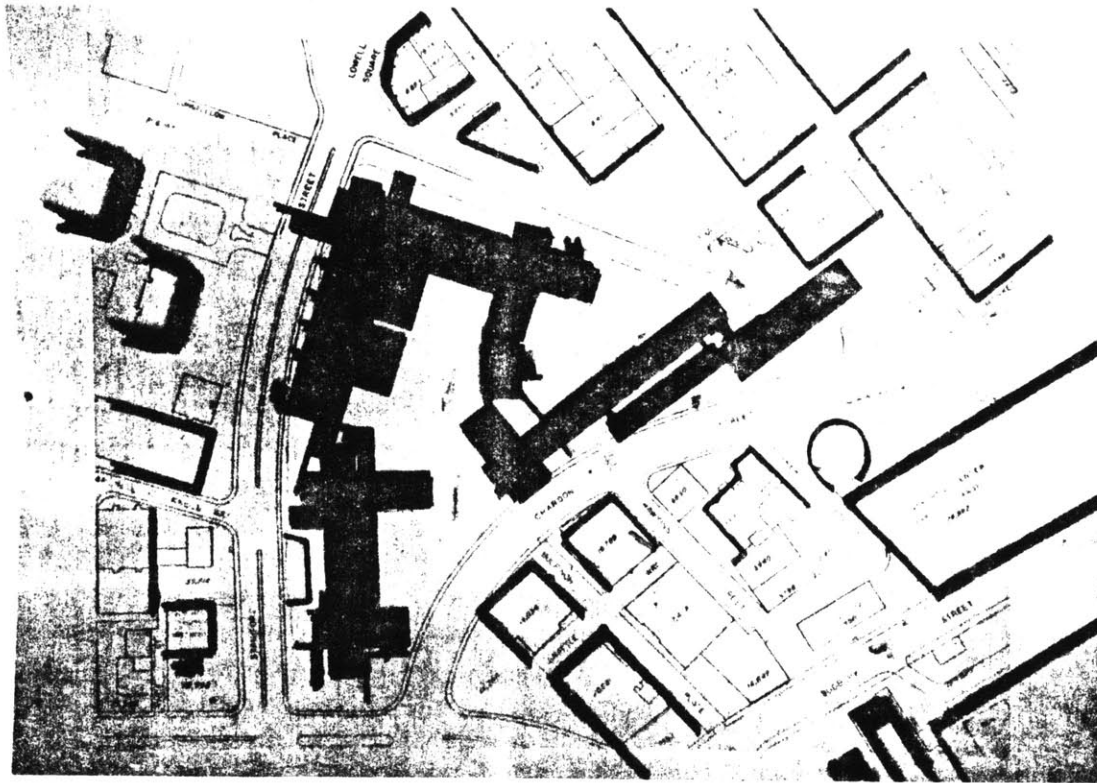

(f.2.1)

2.1 Site Information

"Broadly speaking, 'structure' stands for the collective, general, (more) objective, and permits interpretation in terms of what is expected and demanded of it in a specific situation. One could also speak of structure in connection with a building or an urban plan: a large form with, changing little or not at all, is suitable and adequate for accommodating different situations because for accommodating different situations because it offers fresh opportunities time and again for new uses."⁵

The site of the Government Center is located off of the New Chardon Street, immediately adjacent to the Lindemann Mental Health Center and the Government Center Garage. The site is situated at a pivotal location in the Government Center district, at a convergence of major routes into the city from East Boston, Charlestown, and Cambridge.

The first major decision concerning this site was the removal of the existing Boston Government Service Administration Building (GSA) designed by Paul Rudolph. I will not include the GSA building in my thesis because its design embodies a closed form which does not respond to its surroundings.

The proposed New Boston Courthouse project presents an challenging architectural opportunity for creating a needed judiciary facility, and furthering the continuity of excellent civic landmarks which play an important role in the historic cityscape of Boston. Furthermore, the New Courthouse represents an interpretation of the American ideals of democracy and justice in architectural form.

Urban design standards have been developed pertaining to issues of Zoning, Building Heights, Existing Land Uses, Transportation, Urban Design Opportunities, Monuments and Notable Places, and Site Specific Issues:

⁵ Herman Hertzberger, *Lessons for Students in Architecture*, Uitgeverij 010 Publishers, Rotterdam

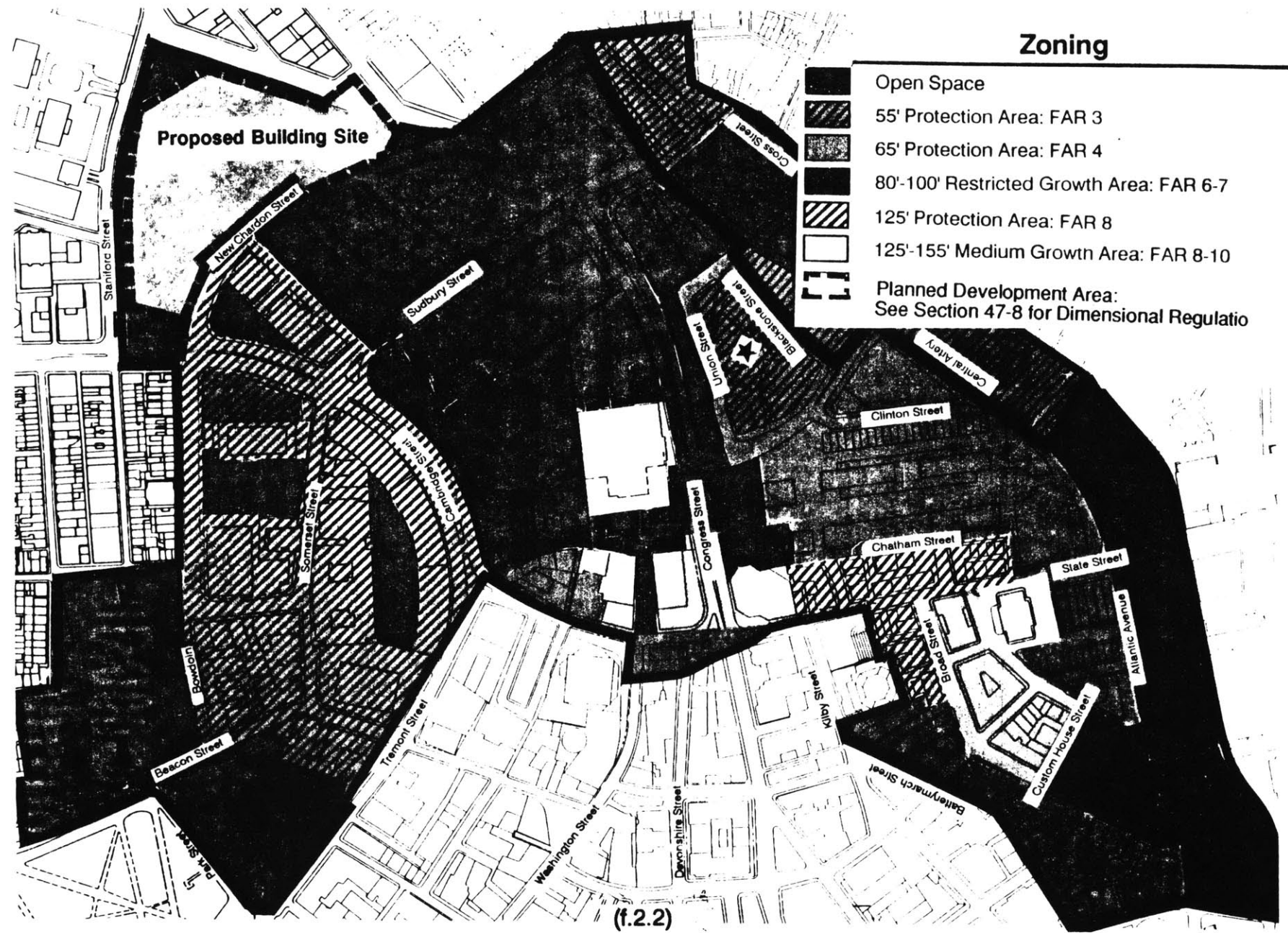

Monuments and Notable Places

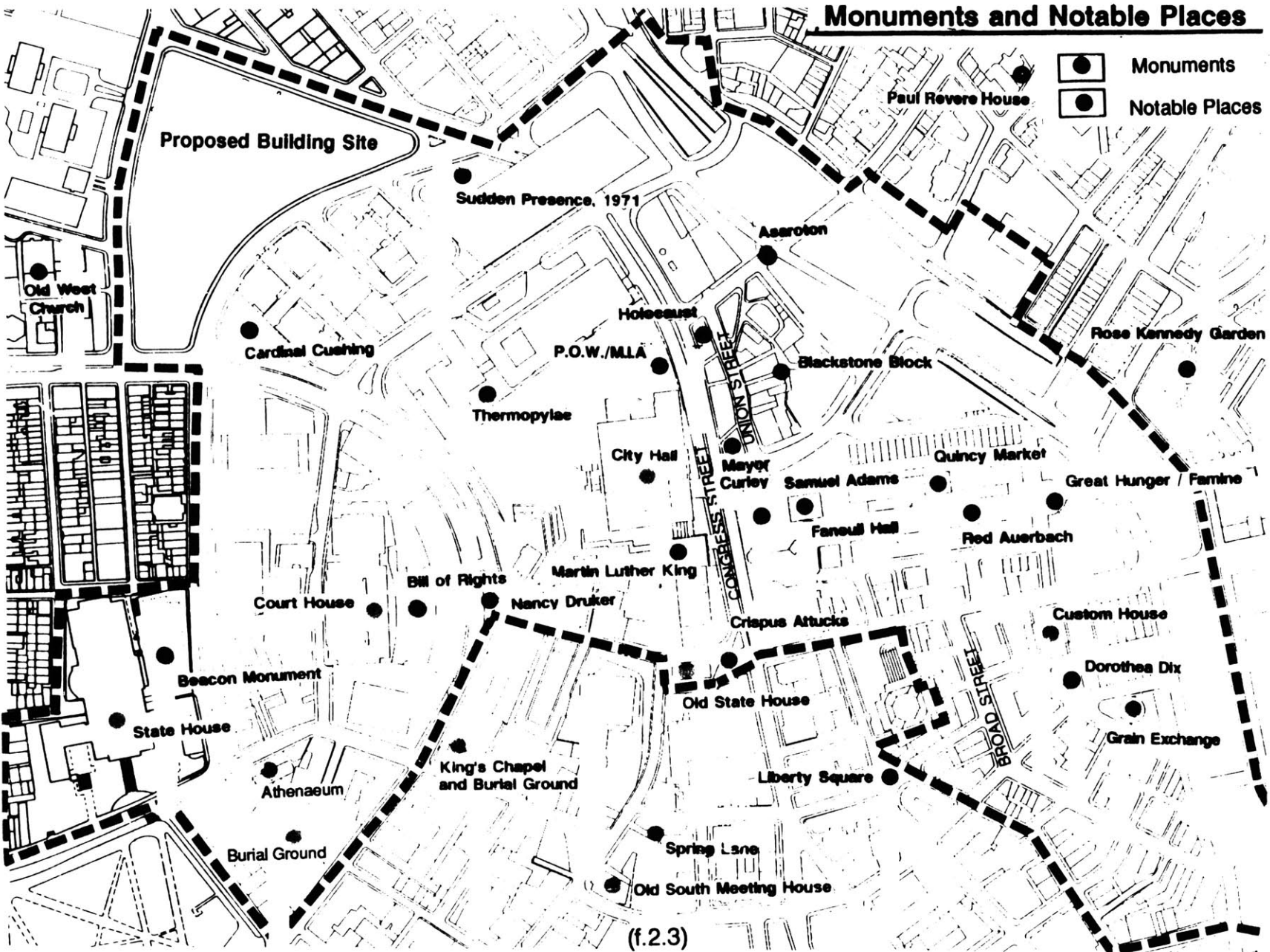

(f.2.3)

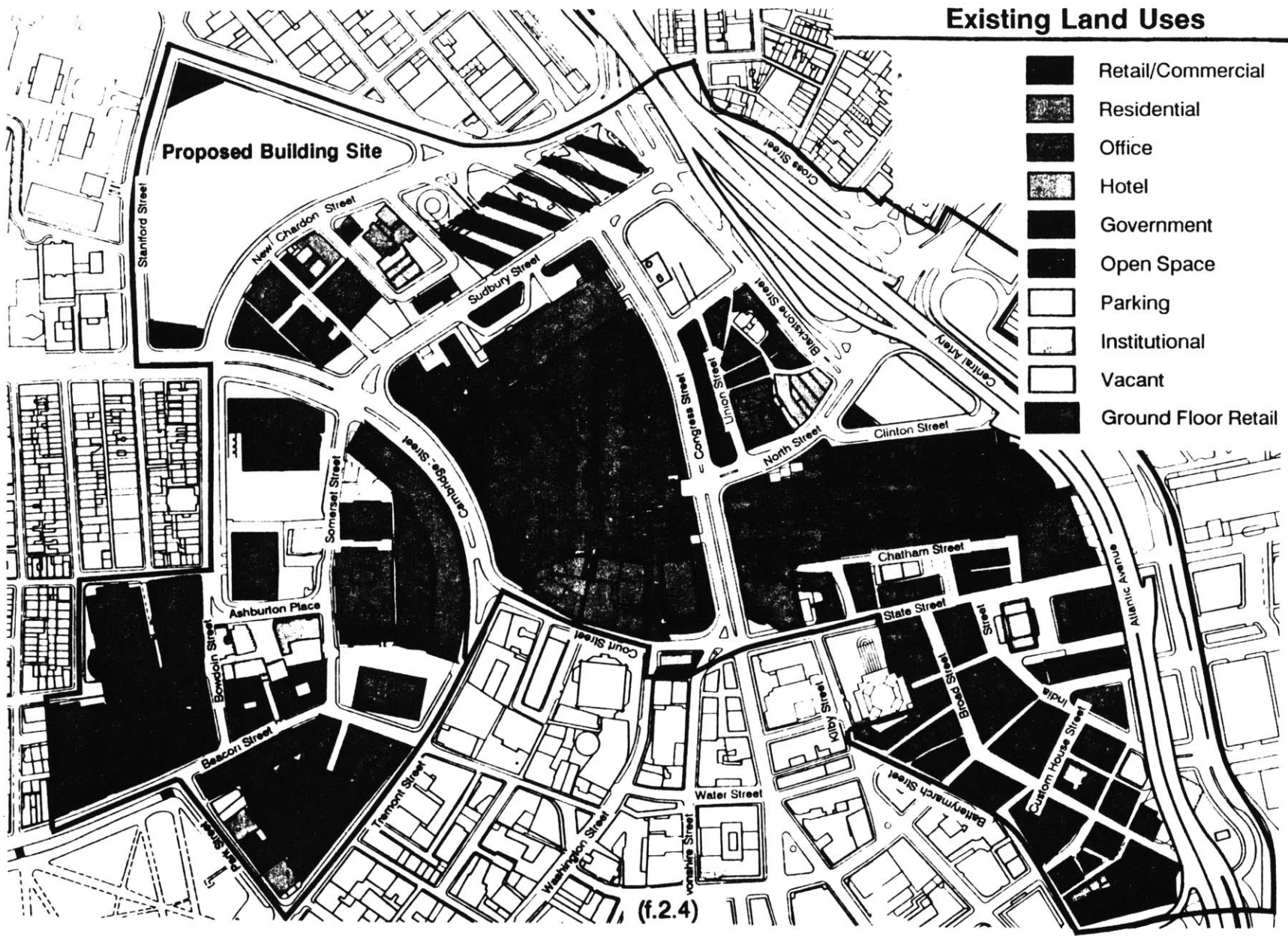

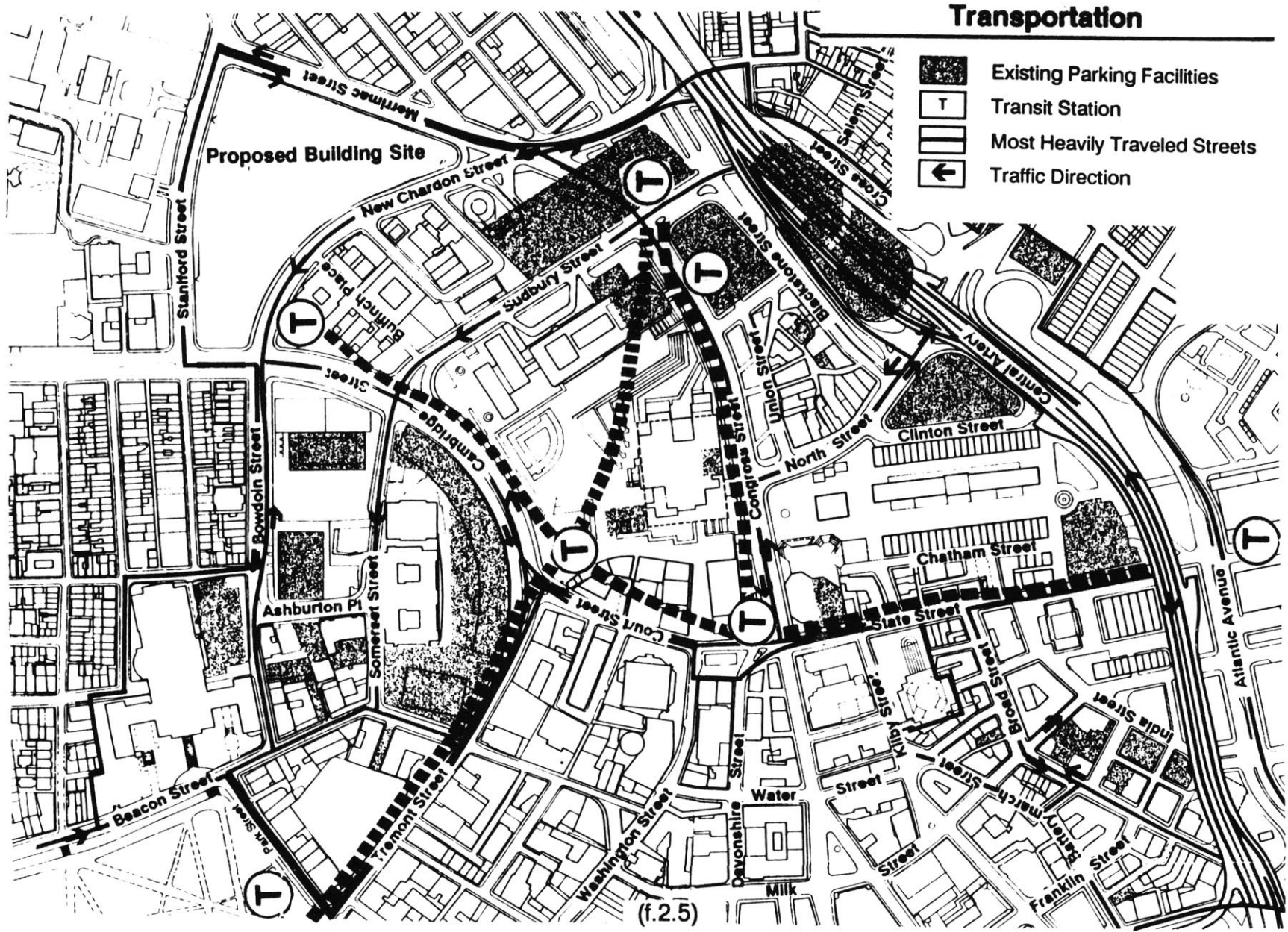





Transportation

-  Existing Parking Facilities
-  Transit Station
-  Most Heavily Traveled Streets
-  Traffic Direction

Proposed Building Site

(f.2.5)

Urban Design Opportunities

-  Open Space Opportunity
-  Development Opportunity
-  Pedestrian Connection
-  View Corridor
-  Bridge
-  Freedom Trail
-  District Boundary
-  Broad Street Corridor

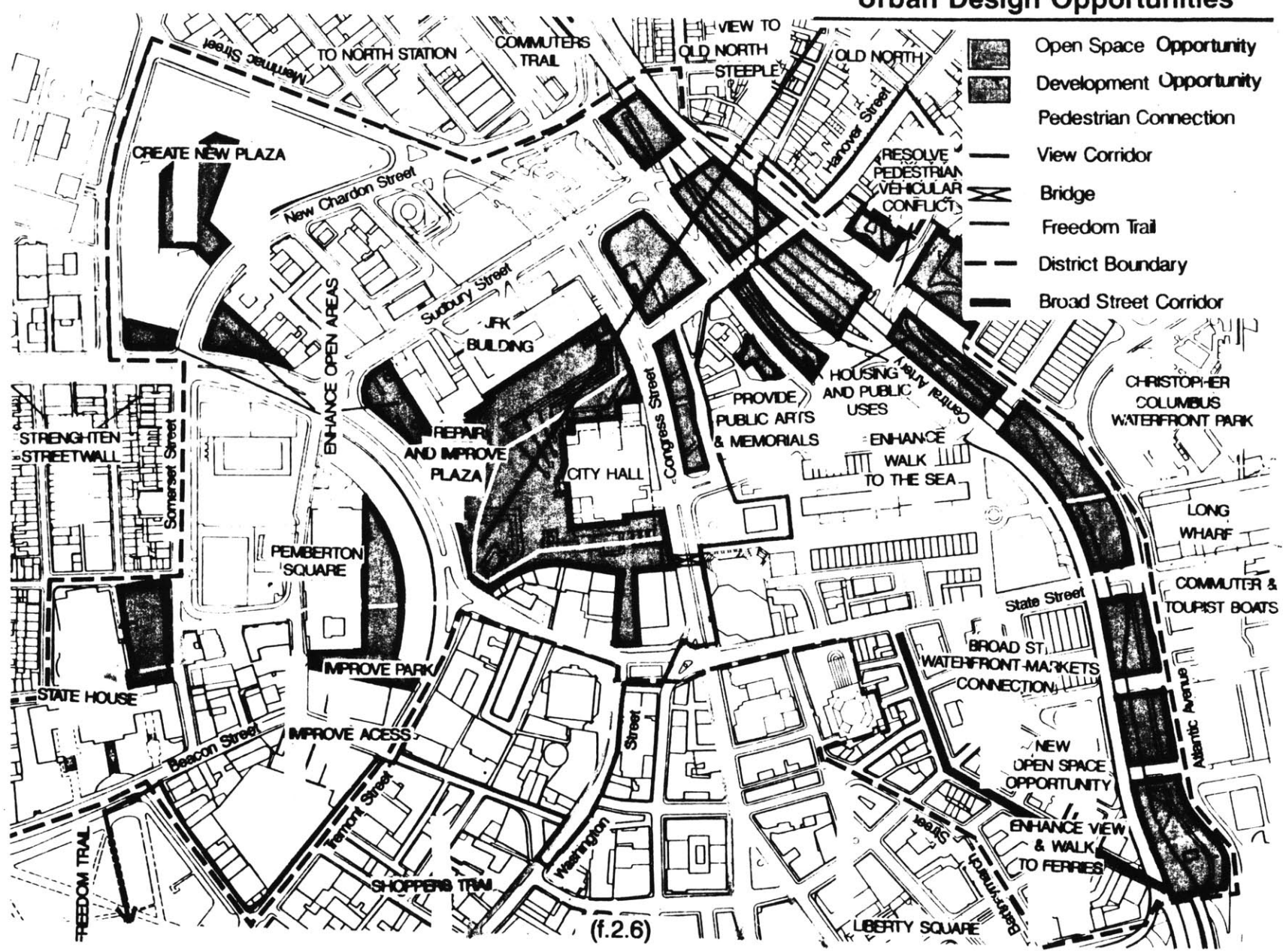

Building Heights

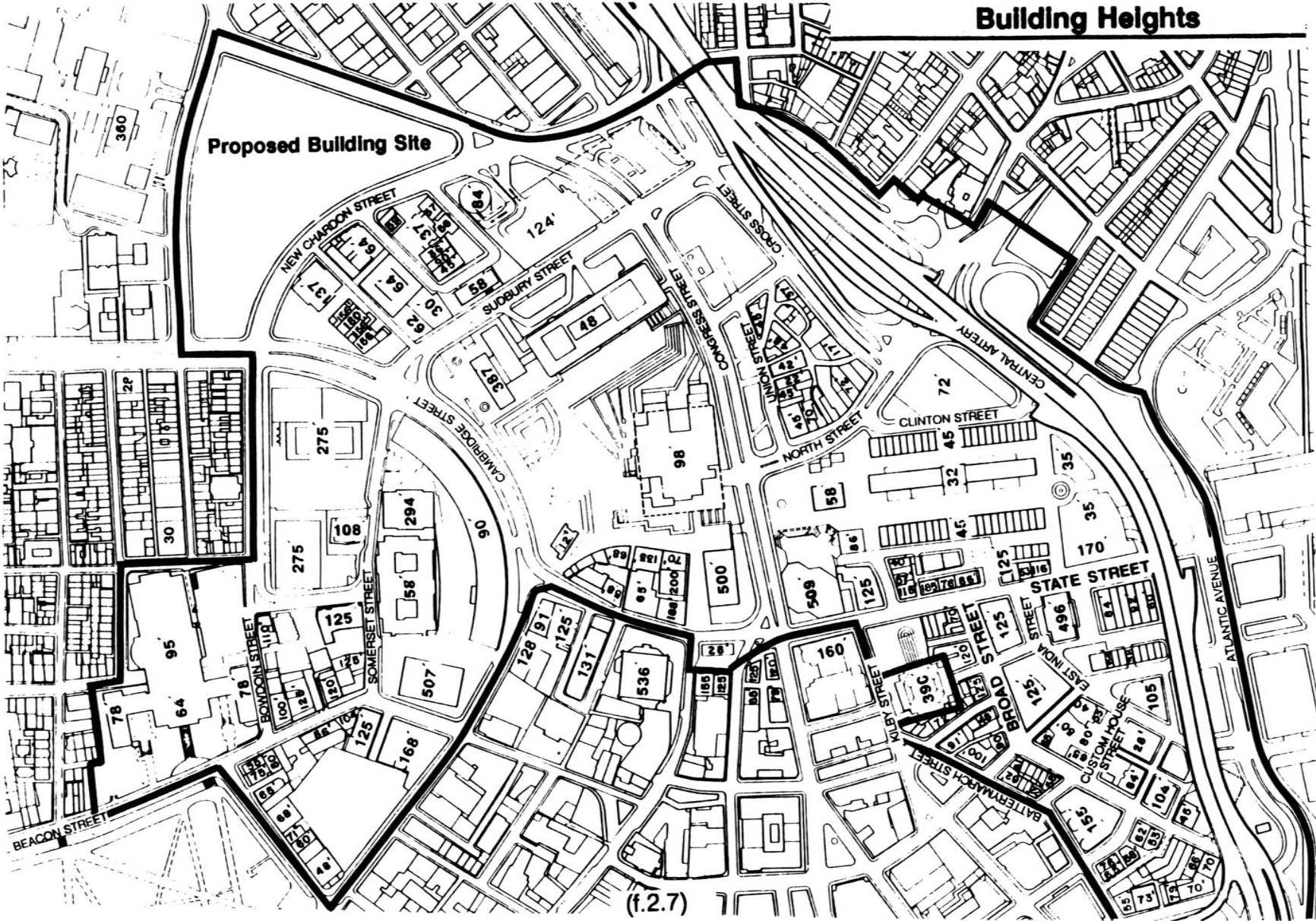

Site Specifics

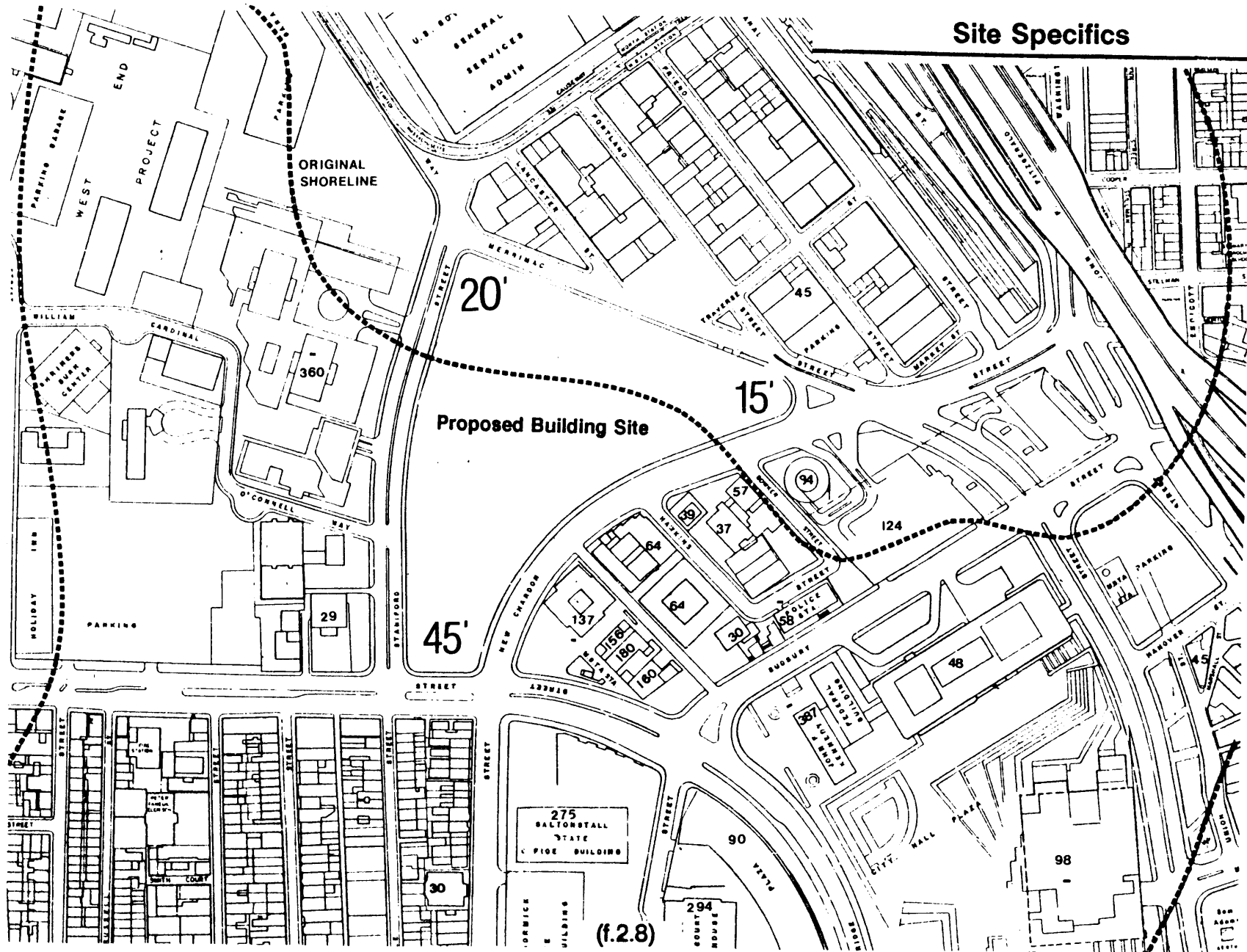

(f.2.8)

Zoning:	
1)	The height limitation of the site is from 125 feet to 155 feet: medium growth area. (f.2.2)
2)	The present site FAR is 8-10. (fig.2.2)
Monuments and Notable Places:	
3)	There are three notable monuments and places that should affect the design of the courthouse building. They are the Old West Church, Cardinal Cushing, and Sudden Presence 1971.(f.2.3)
Existing Land Uses:	
4)	The proposed courthouse building will contain office, government, open space, parking, institutional, and ground floor retail space. (f.2.4)
Transportation:	
5)	New Chardon Street and Merrimac Street are the two most heavily travelled streets around the perimeter of the site. (f.2.5)
6)	There is one Transit station across New Chardon Street adjacent to the site and the other Transit station under the government parking center garage. (f.2.5)
Urban Design Opportunities:	
7)	I have to take in consideration the progression of open spaces from the central artery through the outdoor space adjacent to city hall all the way towards the site. The opportunity does exist to create new outdoor plazas on and around the site. (f.2.6)
Building Heights:	
8)	Building Heights are diagramed with numerical numbers throughout the plan. (f.2.7)

Site Specifics:	
9)	This site straddles the original shore line of the Boston peninsula, containing 10 feet and 15 feet of miscellaneous fill over soft organic clay layers. (f.2.8)
10)	The original demolished buildings on the site were supported on wood piles. All basements have been backfilled with miscellaneous fills and building debris. (f.2.8)
11)	Ground water table is approximately 15 feet below grade of the northeast portion, approximately 20 feet below at the north west portion of the site, and approximately 45 feet below at the southwest portion of the site. (f.2.8)
12)	The foundations for the proposed building would be piles or caissons bearing on bedrock. The length of the piles would be between 45 feet and 60 feet, depending upon the location on the site.

2.2 Site Analysis

*'The localized fragments of the urban landscape's surroundings contain many qualities that one could gather, including various sizes, contained spaces, and extensions. Yet, it is the direction that provides the primary structural property of this urban field.'*⁶

By analyzing the surrounding fragments of the urban cityscape, there exists a spatial movement through the urban cityscape at a northwest/west direction.

The portion of the urban cityscape labeled A, Beacon Hill, illustrates the directional continuity that moves east to west, while the street movement runs north to south (f.2.9). The portion of the site labeled B is at a 45 degree shift to area A. Here, Hawkins Street, Bowker Street, and Bulfinch Street have an influence on the courthouse building facing New Chardon Street.

The portion of the site labeled C, the West End Project, consists of modern residential high rise towers built during the 60's. The directional field established through the combination of these buildings deviates 27½ degrees from Beacon Hill. The Warehouse district, labelled D of the site, is made of the original building fabric of the city. The existing buildings are currently at a quality of finish that existed in old Boston around 1900's. These buildings are slightly skewed from portion B. Behind these buildings are the U.S. Governmental General Services Building, North Station, and Boston Garden.

The portion of the site labeled G is the Government Center where the old courthouse and state office buildings coexist. These buildings are large in form. The majority of these buildings conform with the directional geometry

⁶ Thomas Robert Chastain, Explorations of Collective Form: A Design Vocabulary Using Directional Village Forms as Reference', pp. 62-63.

Site Analysis

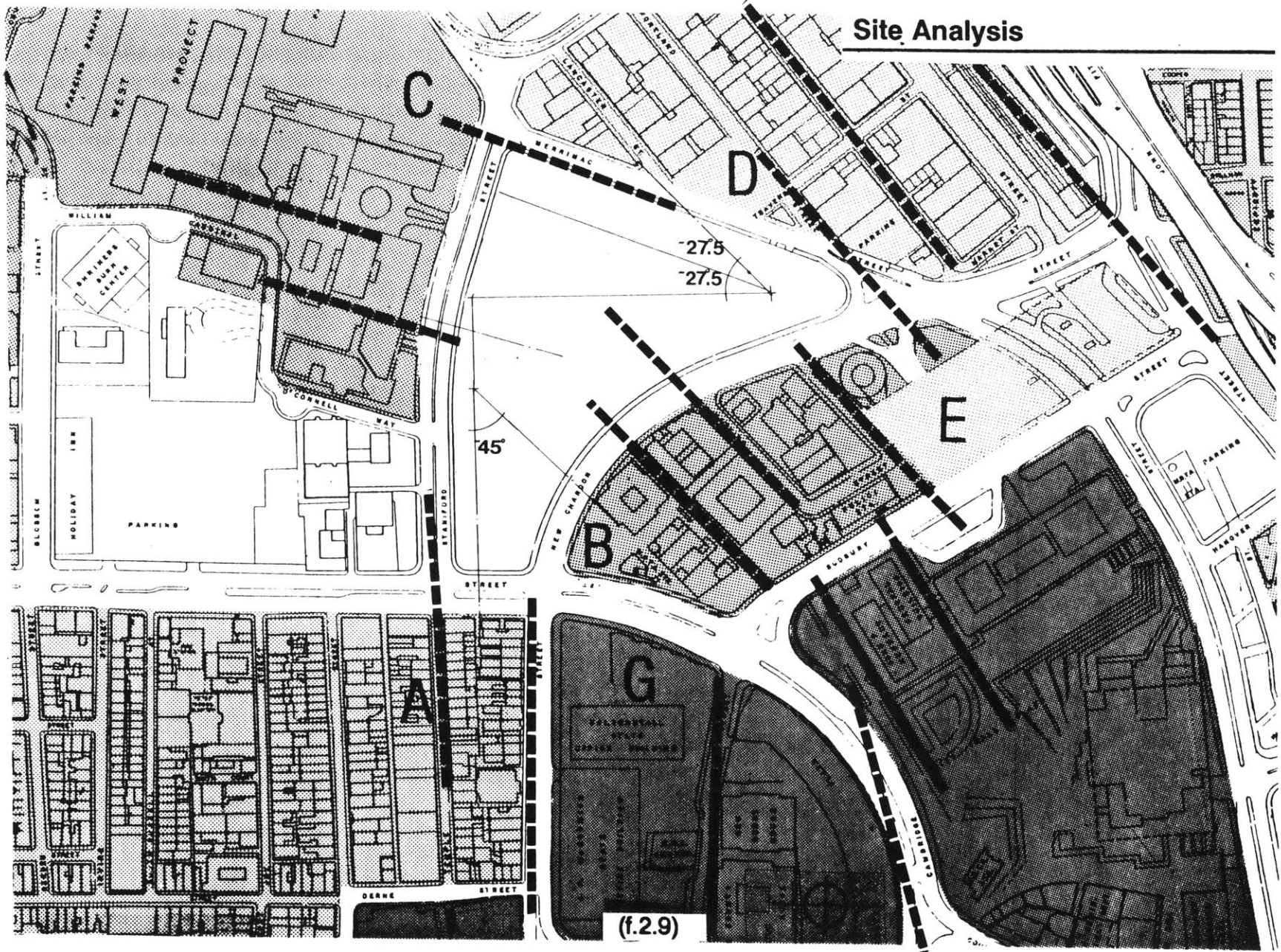

of Beacon Hill, except for the Center Plaza Building, which in itself forms an important urban edge, and whose street movement proceeds from the financial district to the site. The portion of the site labeled F (the North End), mostly composed of residential and some commercial uses, is the portion of the urban landscape exerting the least spatial influence on the courthouse site.

2.3 Site Access Criteria

I plan to take advantage of the site's positive features, such as the topographic grade changes which will allow direct service access to lower floors off Merrimack Street and New Chardon Street.

The new courthouse building will facilitate a range of other functional access requirements. Access for future daily building users consists of the following range: secure parking spaces for judges; the Marshall's sallyport spaces for inmates; service and delivery vehicles; staff; jurors; witnesses; attorneys; and public and pedestrian visitors, among others.

Achieving clarity and efficiency for these potentially conflicting access points is particularly difficult on this site. In this situation, multi-ground levels may be required. The varying degrees of access to this building can be easily identified in their relationship to different reference levels. The site must allow for a configuration of the building which will support the clarity of the different access movements. The sectional drawing should help illustrate this idea. (f.2.10)

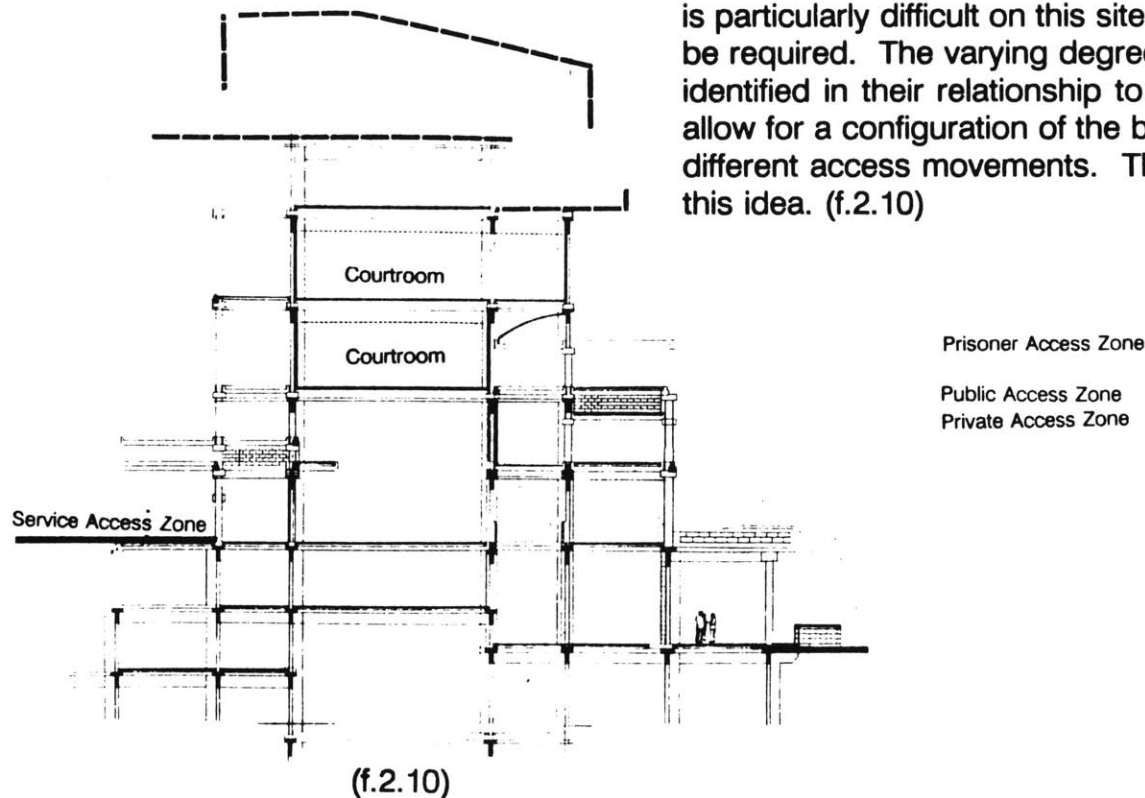

2.4 Street Use

*'Any attempt in understanding the meanings of street as well as their role in the processes of human communication and interaction requires a conception, as well as some comprehension of the specific role or roles played by the street in this relationship.'*⁷

The street is a collection of building blocks. It should be the expression of a plurality of individuals inhabiting mostly private buildings. The exterior street space left over between building blocks and the sequence of these street spaces will be used daily by the inhabitants of the surrounding site and the courthouse building. These "leftover" exterior street spaces should accommodate community activities and governmental celebrations and should also allow for other social gatherings. For instance, local inhabitants could assemble in the north courtyard facing Merrimac Street (f.2.11). Moreover, the leftover spaces in between buildings should be used as spaces for informal social contact among local residents and courthouse users.

The deterioration of street use around the proposed site's perimeter is due to the following factors:

1. The perimeter of the site is made up of primary streets -- Merrimac Street, Stanford Street, Cambridge Street, and New Chardon Street -- where motorized traffic constantly flows. I plan to extend the courthouse building past the confines of this perimeter onto the Warehouse District outside of the perimeter, to permit inhabitants to have access to the building without having to cross the street.
2. The entry zones into the dwellings and office buildings in the immediate site are inconsiderate to its users due to a shortage of threshold entries. These indirect and impersonal access

⁷ Gloria Levitas, 'Anthropology and Sociology of Streets', p. 225



Street Use

(f.2.11)

routes are exposed to thoroughfare streets like Stanford Street and Merrimac Street. I will transform New Chardon Street from a route of passage to a place of destination. A major civic space will be created in the center court facing the New Chardon Street.

3. The position of the buildings' edges alongside the street does not allow for street use by local inhabitants, particularly in the Warehouse District. These buildings at the Warehouse District situated at the north-east of the site bordering Merrimac Street limit community use.

My intention is to create conditions for more viable street use wherever possible.

2.5 Public and Private Spatial Use

*'Architecture has as its goal of public and private harmony, the happiness and preservation of the individual and the collective.'*⁸

The concept of public and private use comprises two spatial categories: the collective and the individual. To clarify these categories, *'a space that is accessible to everyone at all times is deemed public use. A space whose accessibility is determined by a small group or an individual is deemed private use.'*⁹ These different degrees of urban usage are illustrated in the plan diagram (f.2.12). Here, it shows how these different private and public urban spaces exist throughout the site and (f.2.13), illustrates how these spaces can influence the development of certain spaces throughout the courthouse building.

When designing both public and private spaces of the courthouse building, I am aware of the varying degree of territorial claims made upon it by its users and the degrees of accessibility that may exist for its users in adjoining spaces. In effect, I express these differences through the articulation of composition, form, material, light, and color, which imply a certain ordering.

This ordering does, in effect, offer a set of generic standards for the design of public and private spaces in courthouse design, depending upon which territorial claims have been established by its users, and in reference to accessibility of the space in question.

⁸ J.N.L. Durand *Precis des Lecons*, op. cit., Vol. I, p.15.

⁹ Herman Hertzberger, *'Buildings and Projects' 1959-1986*, Den Haag, A. Lchinger, 1987, p.39.

Courthouse Urban Spaces

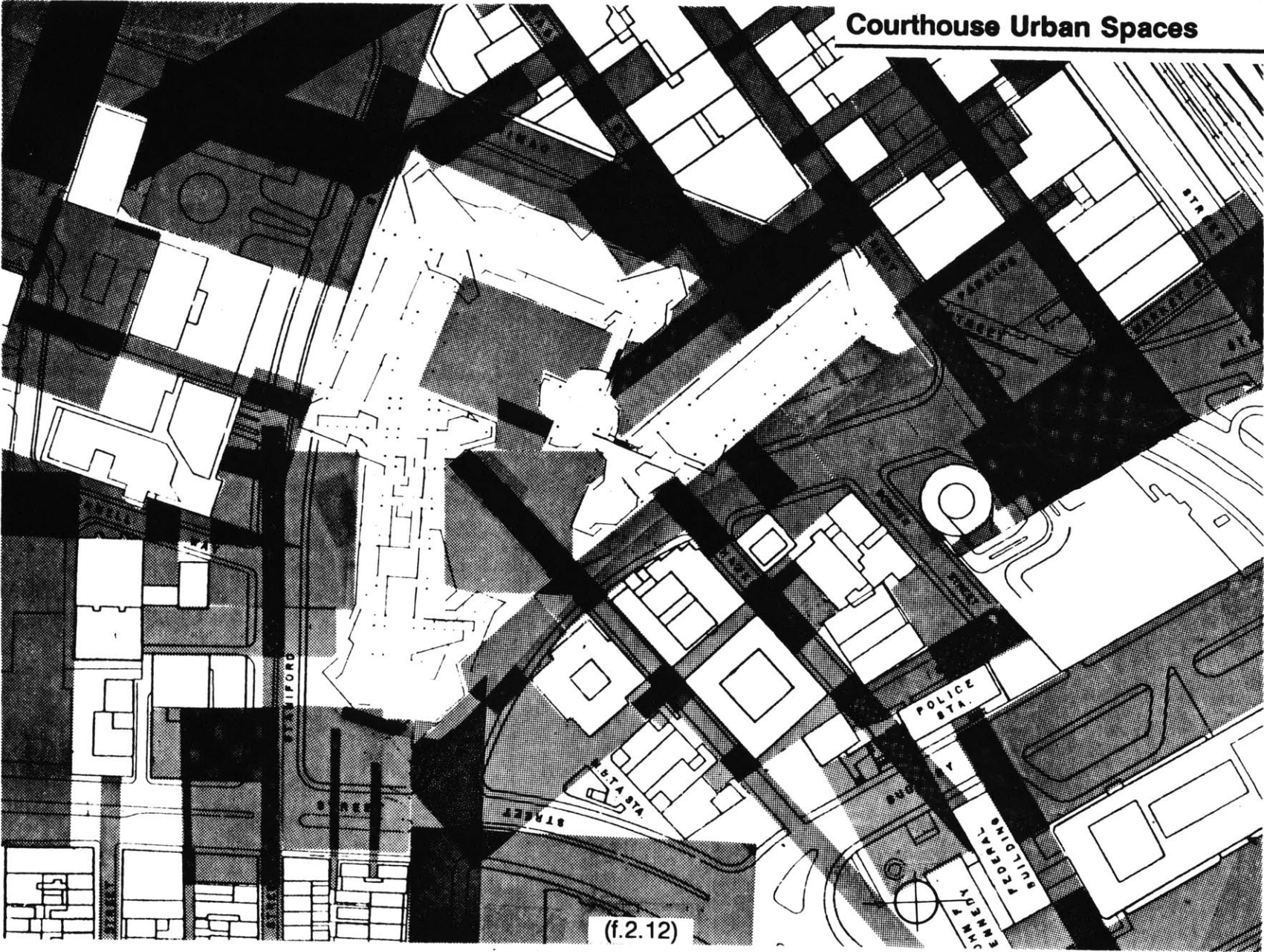

(f.2.12)

Existing Urban Spaces

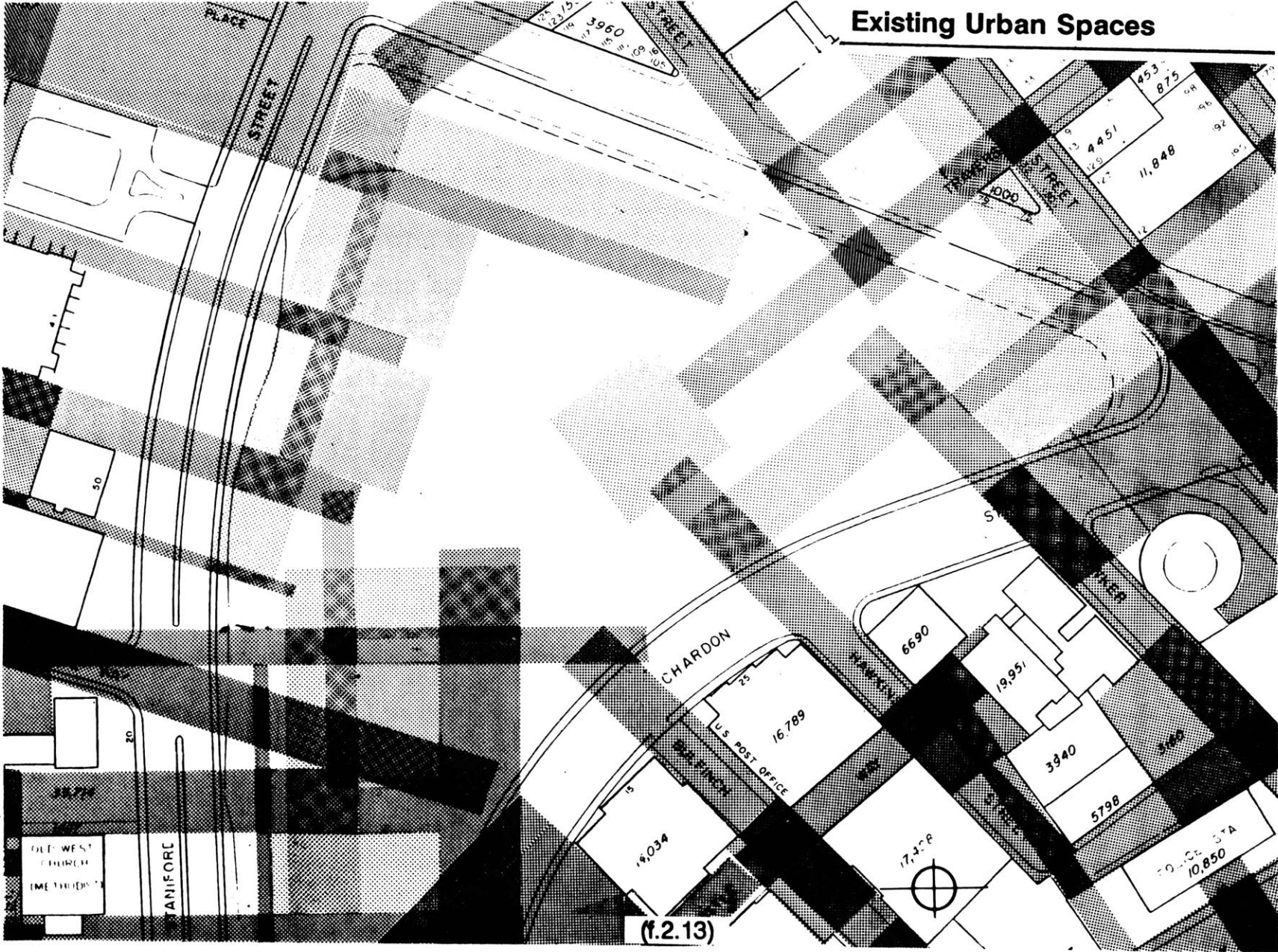

(f.2.13)

2.6 Urban Dimensional Stabilities

The use of dimensions should allow for a direct understanding of similar ranges of sizes and dimensions throughout the urban landscape. In turn, this understanding would:

- allow for a direct and optional intensification of an already existing urban landscape.
- guarantee a continuity of urban landscape and built physical definitions.
- offer a maximum of use options to be chosen with the intensification of dimensional ranges.
- avoid the building of discontinuous singular objects in the field.¹⁰

Column 1	Column 2	Column 3	Row
10			1
	10		2
20		10	3
	20		4
40		20	5
	40		6
80		30	7
	70		8
150		40	9
	110		10
260		50	11
	160		12
320		60	13
	220		14
540		70	15
	290		16
830		80	17
	370		18
		90	19

(f.2.17)

After the dimensional analysis of the site (f.2.14), I arrived at a set of existing urban dimensions throughout the urban cityscape. Preliminary courthouse dimensions (f.2.15) led to the final plan drawing of the courthouse building with dimensions (f.2.16). These numerical dimensions were further refined leading to a numerical matrix chart (f.2.17). This chart dictates basic modular dimensions for the spatial and structural elements of the courthouse building (f.2.18).

The matrix chart is composed of three columns. Column 3 is multiples of 10 through 90. Column 2 also starts with the number 10 at Row 2, and by adding number 10 in Column 3 at Row 3, the result is 20 in Column 2 at Row 4 (i.e., $10 + 10 = 20$ \triangleright $20 + 20 = 40$ \triangleright $40 + 30 = 70$ \triangleright $70 + 40 = 110$ \triangleright $110 + 50 = 160$). Following this numerical sequence, Column 1 also starts with number 10 at Row 1. By adding 10 in Column 2 at Row 2, the result is 20 in Column 1 at Row 3, and so forth. The resulting numerical sequence in Column 1 comes close to the dimensions of the existing plan.

¹⁰ Morris K. Smith, Design Lecture, M.I.T. Fall 1990

Existing Urban Dimensions of The Site

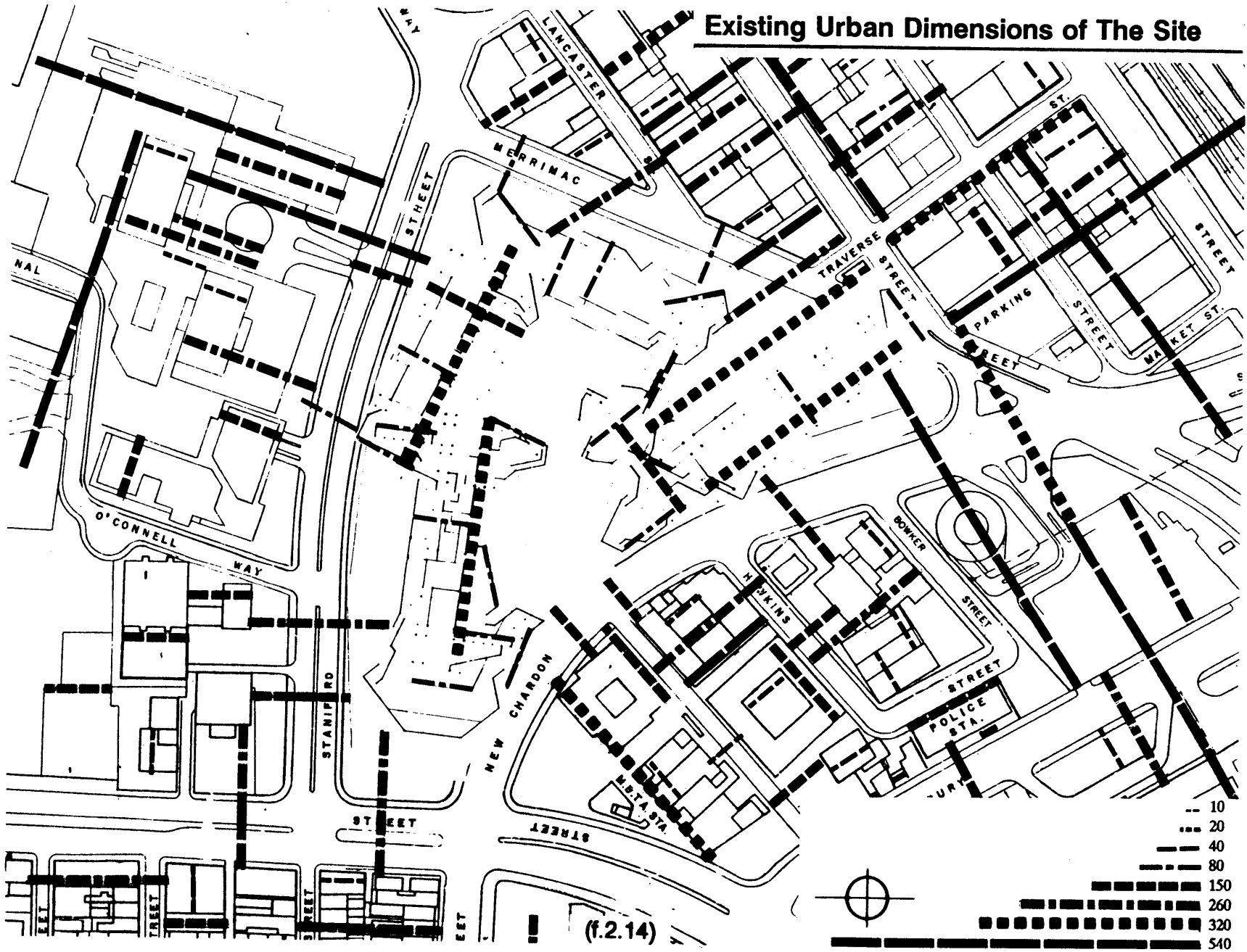

Preliminary Courthouse Urban Dimensions

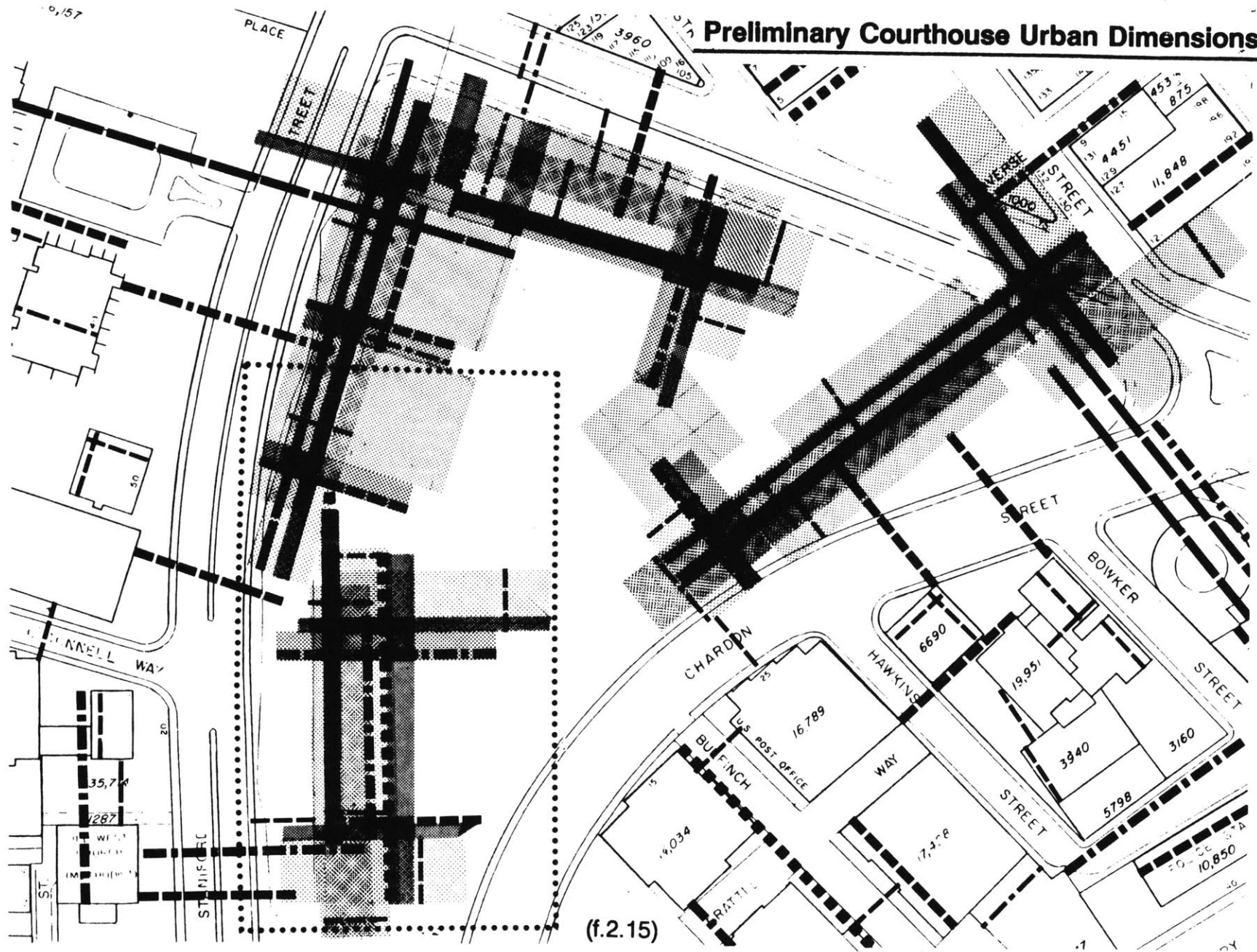

(f.2.15)

Courthouse Urban Dimensions

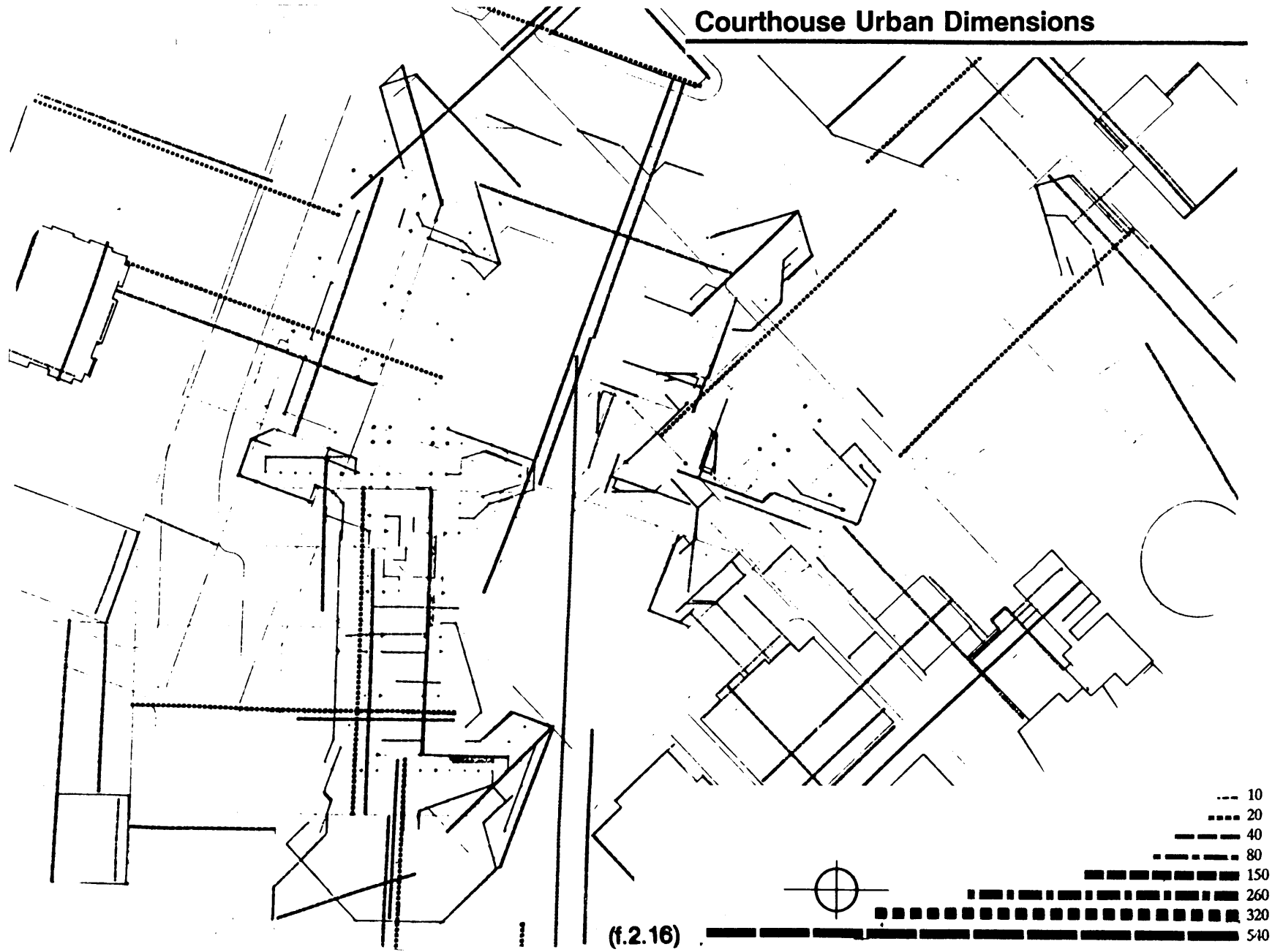

(f.2.16)

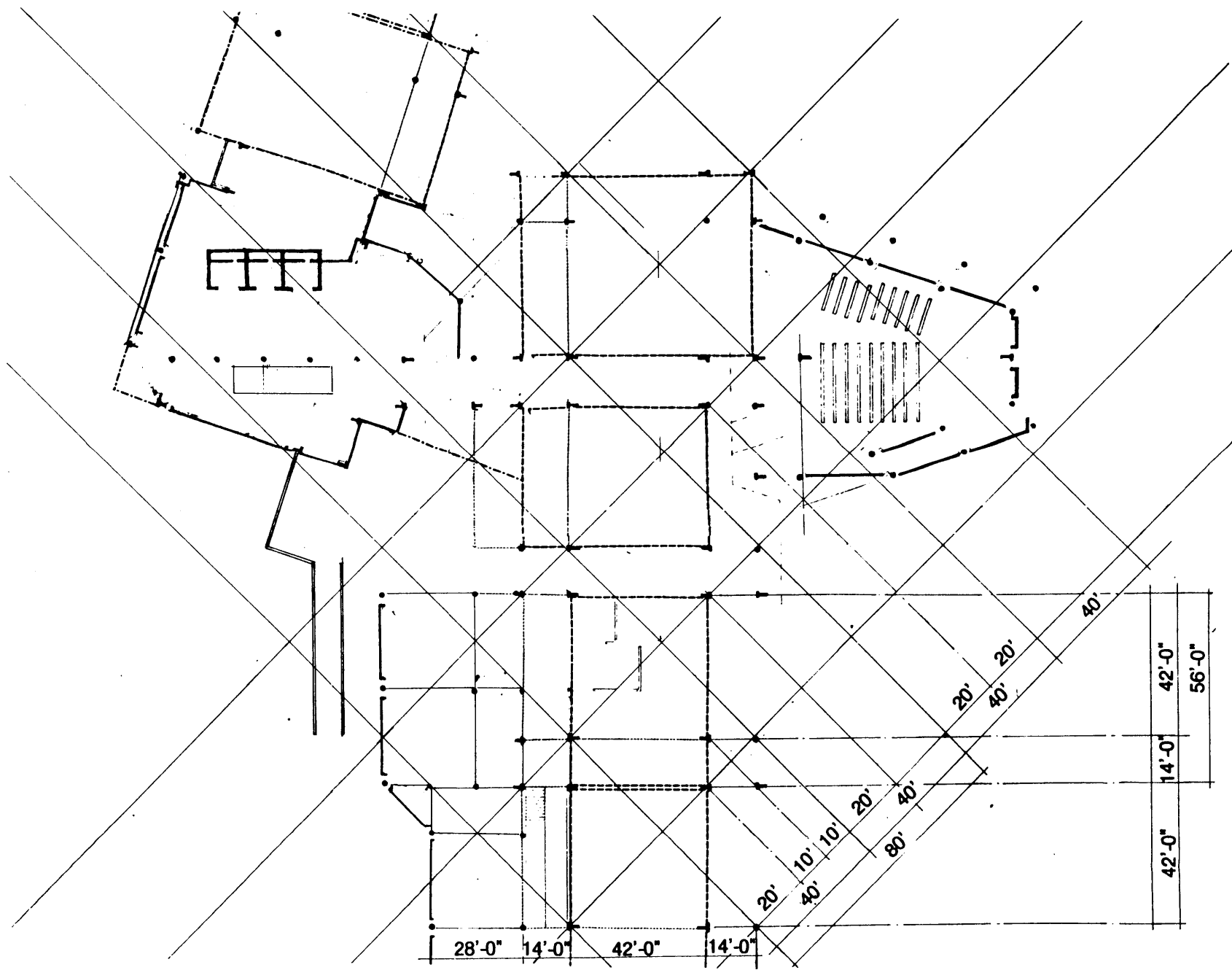

Courthouse Structural Module Dimensions

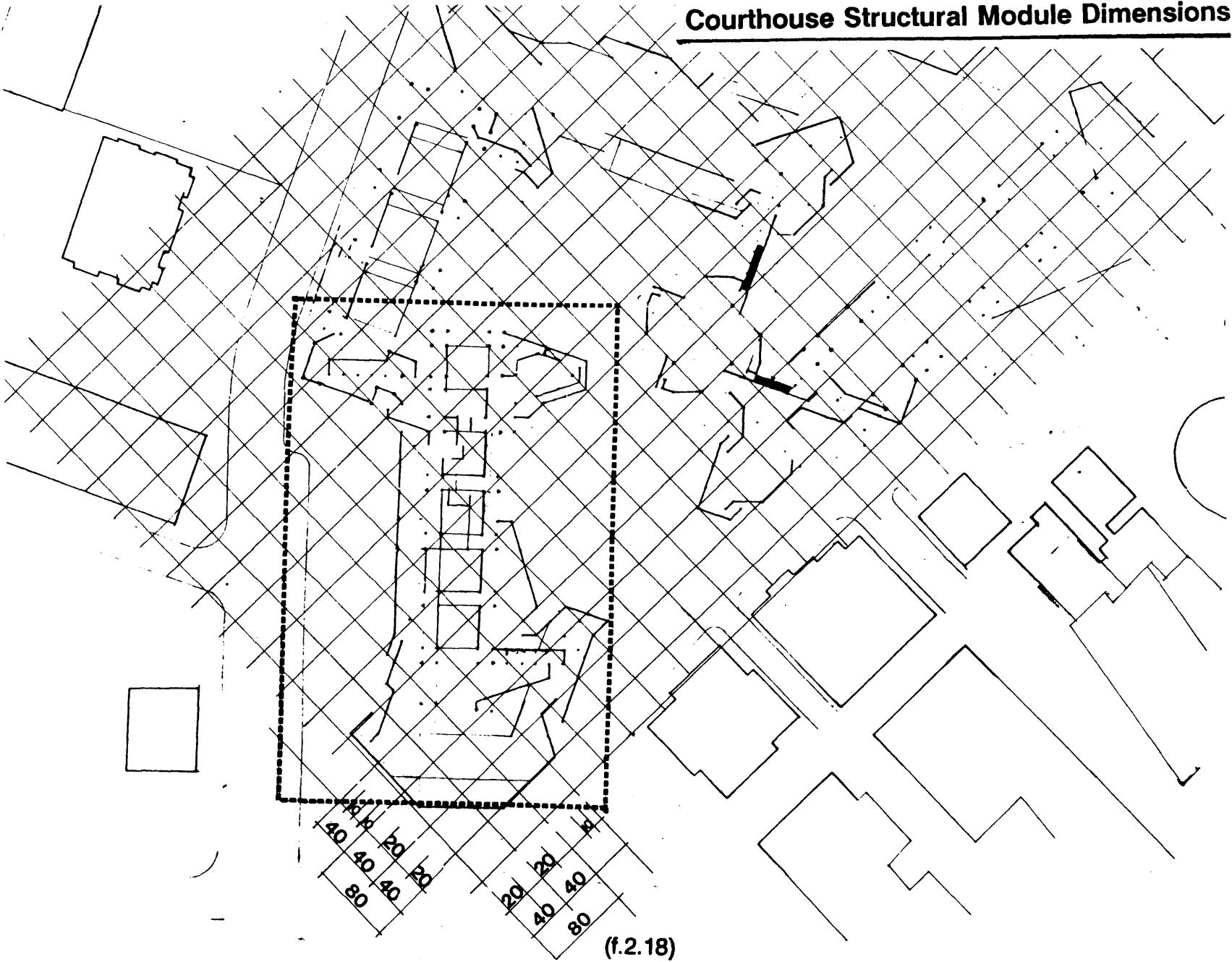

(f.2.18)

2.7 Indoor and Outdoor Use Exchange

*'Just as the application indoors of spatial organization and the materials that refer to the outdoor world make the inside seem less intimate, so spacial references to the indoor world make the outside seem more intimate.'*¹¹

An important factor for the design of the Courthouse Building is outside views. Just as spacial relationships influence personal relations, they will determine the way the users of the courthouse will relate to the outside environment. Views can be accomplished by the use of large expanses of glazing throughout the enclosure system. I will also consider the impact glazing will have upon the quality of space inside the Courthouse Building.

Opening up the corners of habitable space expands the angle of vision. The structural system will reveal this expansion of vision by projecting bays from the enclosure system, enabling the user to step outside, so that the individual has a view up and down the street below (f.2.19). These open corners are enclosed by glazing. The resulting effect should create a spatial continuity between outdoor and indoor, implying a lighter and less massive structural system at the very end points where one would expect structural rigidity. This change in equilibrium results in a shift of emphasis, thereby altering the rhythm of the structure to become open at the beginning and at the end of the structural elements.

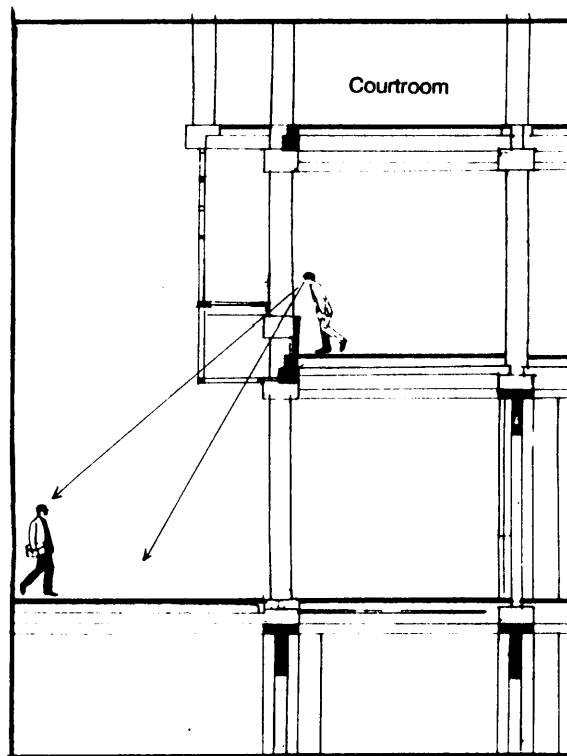
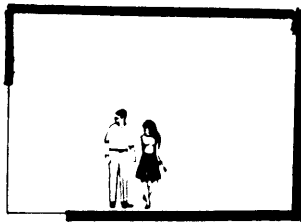

(f.2.19)

¹¹ Herman Hertzberger, 'Lessons For Students in Architecture', Uitgeverij 010 Publishers, Rotterdam, 1989, p.86.



By virtue of this idea, the focus of attention shifts by attracting the eye upward, downward, and to the street outside. In addition, I have considered the quality of light entering through the enclosure which changes when light enters the collective space at the openings of the corners. Outside light is channelled and cast into indoor collective space. For instance, the surrounding courtroom spaces and atriums also need to relate to the outside world. This can be seen on the sectional drawing (f.2.20).

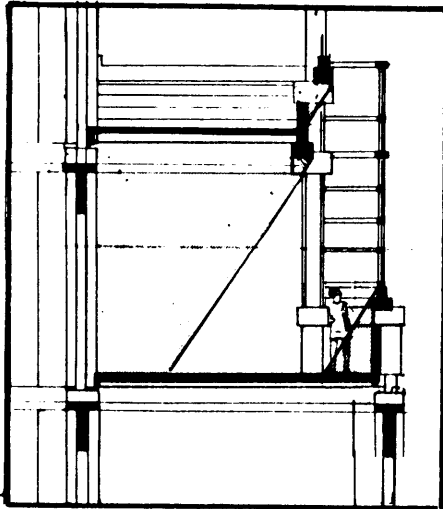

(f.2.20)

2.8 Threshold

*'the front entrance to this space is divested of its significance as a single and abrupt moment; it is extended into a threshold, forming a step-by-step sequence of intermediary spaces which are not yet explicitly part of the lobby, but also less explicitly part of the street.'*¹²

A threshold is a spatial condition that establishes a dialogue between territories of different order, resulting with intermediary spaces that permit an easy transition from one space to another. (f.2.21)

These intermediary spaces are seen as the overlapping of outdoor and indoor zones. On the ground level of the courthouse, these intermediary spaces belong to outdoor and indoor spaces. The principle of threshold at the entrance off New Chardon Street is illustrated on the plan drawing (f.2.22).

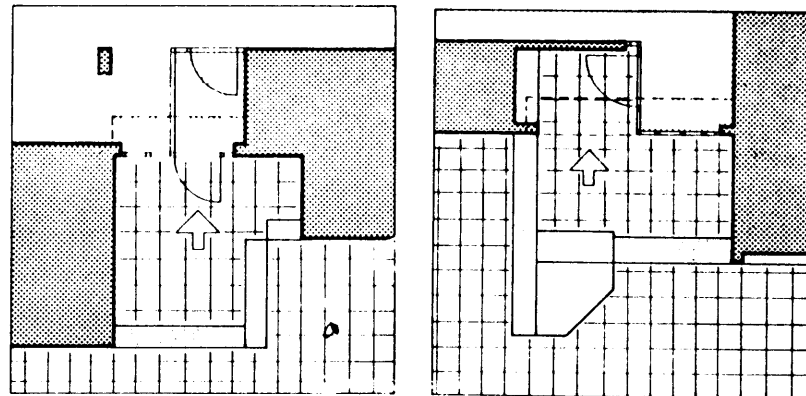

(f.2.21)

¹² Herman Hertzberger, 'Buildings and Projects', 1959-1986, Den Haag, A., Lchinger, 1987, p.9.

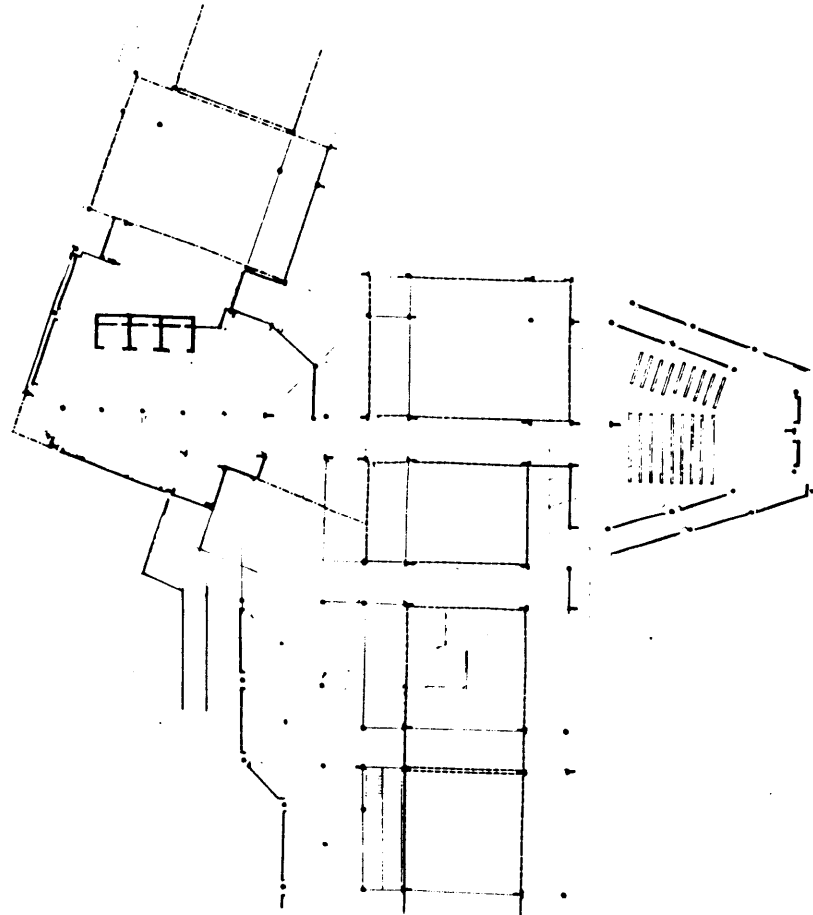

(f.2.22)

Section 3. Internal Spatial Organization of the Courthouse Building

*'..so here we are not talking about a notion of form that presupposes and maintains a formal and unalterable relation between object and viewer. We are not here concerned with a visual appearance as a shell around the object, but with form in the sense of accomodating capacity and potential bearer of meaning.'*¹³

The single operational issue with the greatest impact on the overall internal organization of this courthouse building is zoning, which is the relationship of courthouse spaces with respect to access movement separated into distinct use zones. This differentiation is intended to protect litigants and court personnel, to separate prisoners from innocent people, and to optimize movement throughout the courthouse building.

The impact of zoning on the courthouse design is important, and a significant challenge for me. Successfully addressing zoning will have a direct bearing on the ultimate building form, structural systems, core elements, location of conveying systems, net to gross efficiency, component deployments, opportunities for viewing and lighting, operational efficiency, adaptable HVAC systems, and use of modular planning grids.

The rest of the interior should be designed on the premise that a lot of people are going to spend considerable amount of time within the confines of the courthouse. Their stay, ranging from hours to days, should be as pleasant as possible. To achieve this flexibility, a variety of requirements should be addressed at the design stage. The courthouse spaces should be well lighted, have a lot of waiting areas for people en route to courts, cafeterias, and other facilities.

¹³ Hereman Hertzberger, 'Lessons for students in Architecture', Uitgeverij 010 Publishers, Rotterdam

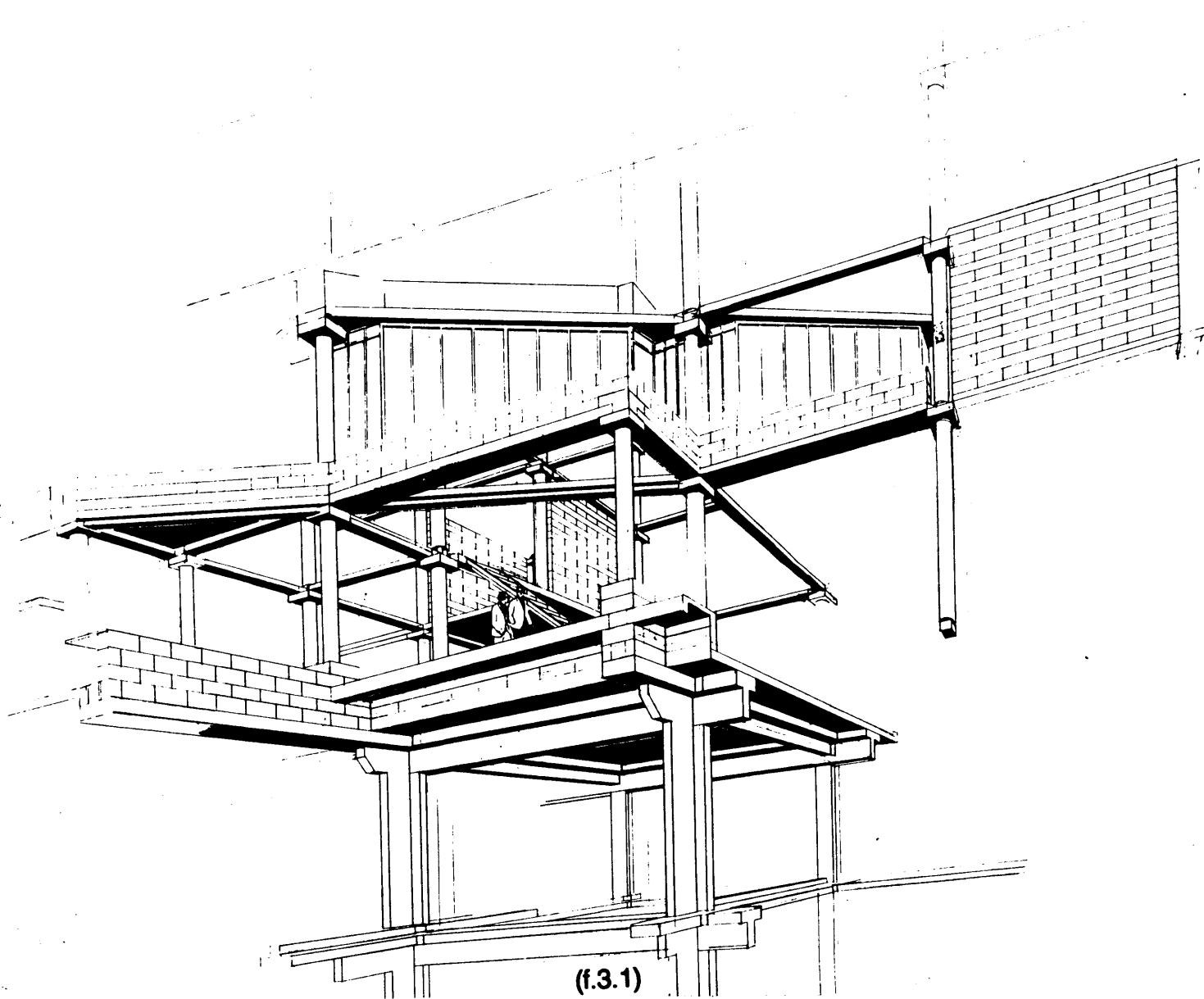

(f.3.1)

3.1 Access Zones of Exchange

*'Any architect should try make objects more substantial, and less two dimensional, by thinking more in terms of spatial zones. The designer should make such intensifications constantly, more like second nature to the architect.'*¹⁴

Different access zones must be distinct for the development of proper movement throughout the courthouse building. In order to make these access zones clear, I will first address the issues of public and private access. Public access systems will accommodate members of the public community with business at the courthouse which will include main lobbies, atriums, major access routes, public elevators and escalators, and public stairs (f.3.2).

Independent from the public access zone of the complex, a private access zone has to be provided in order to accommodate movement of court staff personnel among chambers, courtrooms, conference areas, lounge spaces, and other staff spaces. Access from this private access zone to the public access zone is provided by few discrete entrance points.

This private access zone should also accommodate movement of jurors and security personnel from the courtrooms to jury deliberation spaces; from a vehicular sallyport located at the lower floors off Merrimack Street through pedestrian sallyports, into secure sallyports through the counter for jury assembly; through sound and security vestibules upon entry into the courtrooms. Prisoners, on the other hand, must not be brought into contact with either the private or public access zones of the courthouse (with the exception of prisoner/attorney interview rooms that will be located adjacent to the courtroom holding cells). Access systems of movement should be organized into spaces that are restricted. Access requirements from area

¹⁴ Herman Hertzberger, 'Lessons For Students in Architecture'. Uitgeverij 010 Publishers, Rotterdam, p.25.

to area within this controlled zone should carefully studied. Each zone and the connecting space between each zone should be treated as a controlled and secure space, equipped with advanced security devices. These access systems can be organized into five distinct spatial zones (f.3.3).

- **Public zone**, will accommodate members of the public community with business at the courthouse which will include main lobbies, atriums, major access routes, public elevators and escalators, and public stairs.
- **Private Zone**, which includes all spaces of the building used by the general public, attorneys, clients, witnesses, and jurors, such as the private collective spaces of the building and all of the shared spaces.
- **Prisoner Zone**, which includes all spaces designed for prisoner entrance, movement, access, visiting, and holding. Typically, U.S. Marshall staff will be the only persons with access to these spaces, with the exception of attorney's who have access to the prisoner/attorney interview rooms adjacent to the courtroom holding cells.
- **Interface Zone**, which includes all of the courtrooms and chambers, and any other spaces where the public, private, and secure zones merge together.
- **Service Zone**, include all of the spaces that are for the building support, which accommodate the service, maintenance, and support functions of the building, such as the building's loading docks, bulk storage, mechanical spaces, and maintenance office.

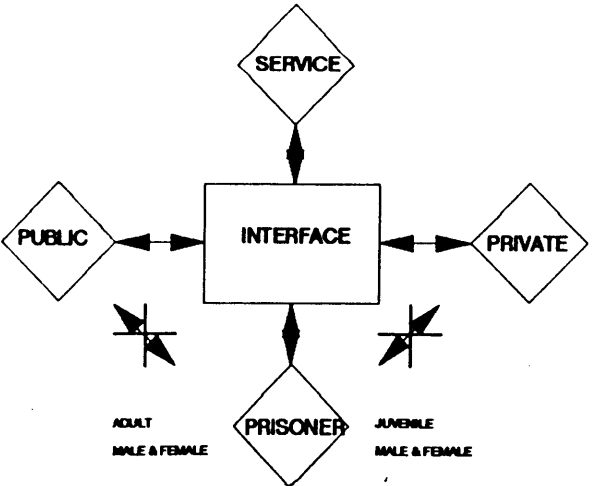

(f.3.3)

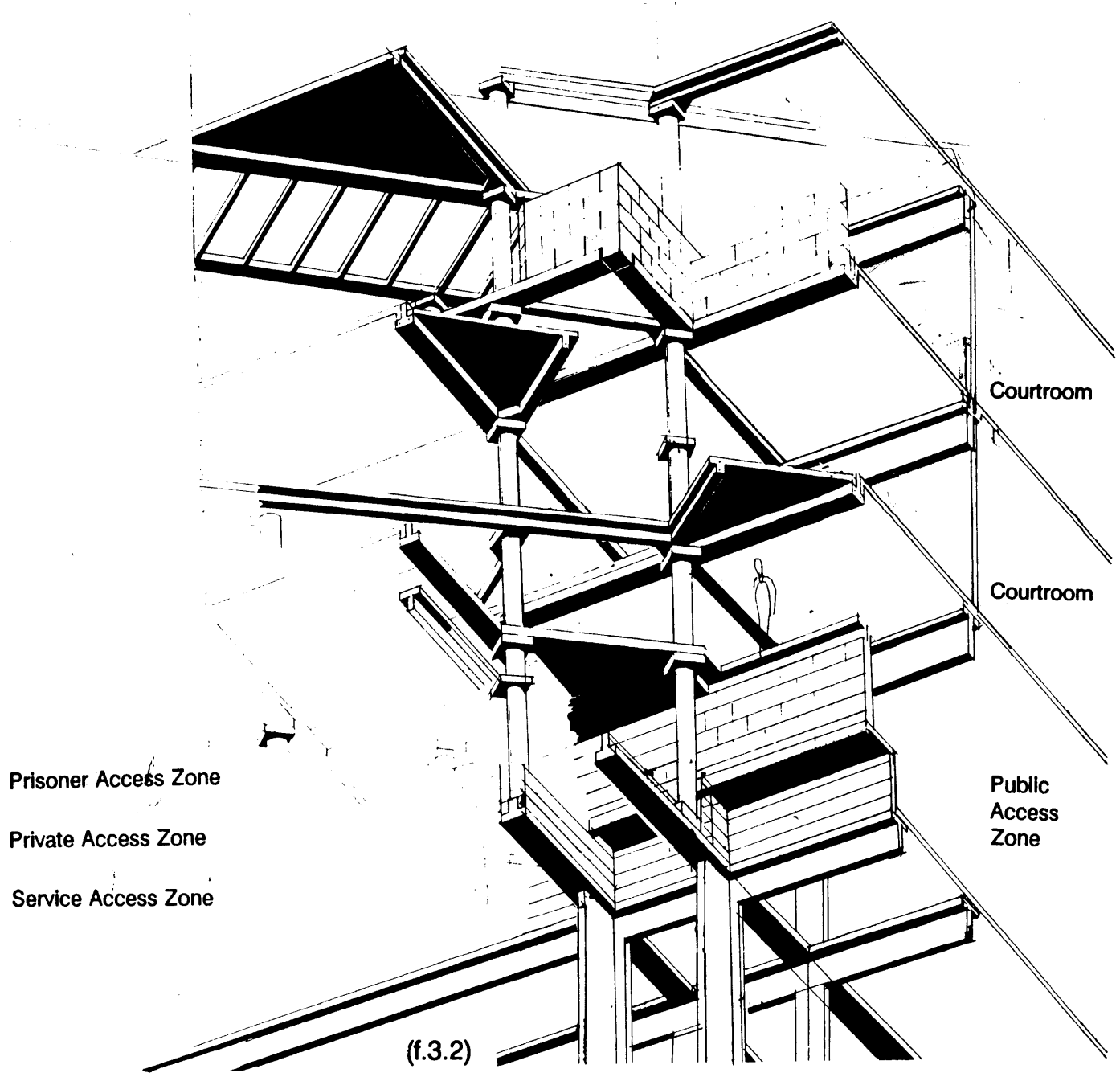

(f.3.2)

3.1.1 Horizontal Zones of Exchange

Courtrooms should be located in quiet zones on the upper floors above the main entry levels. The generic plan layout of these courtrooms in relation to other programmatic requirements, and in relation to access movement, is diagrammed in (f.3.4). The dotted lines represent public access and the dashed lines represent private access. The capital encircled letters P, S, and R signify Parking, Service, and Records, respectively.

The judges will require that the chambers and the private access system connecting them to the courtroom and the outside be efficiently planned, safe, and secure. Private access has less traffic than public access, and is consequently smaller. The judges' chambers are dignified, efficient offices for writing, reading, and research; they are the personal expression of the jurist occupying these chambers. Chamber openings should permit natural light to reach the judges' staff offices. Thus, the glazing of the Courthouse enclosure is extremely important. Fostering an atmosphere suitable for reflection and discussion on the cases and questions before the court is also important.

The law library should be an extension of the chambers. The space should be grand and dignified because of the books of law contained within, as well as providing the computers and terminals necessary for up-to-the-minute information. Like the library, the atmosphere should be respectful of the knowledge housed within; a sense of calm and orderliness for research activities pursued in this space should permeate the environment. This space will have higher ceilings and ample space. Lighting should be interesting yet not obtrusive. This room should be acoustically isolated from public spaces and designed to promote discussion.

Horizontal Zones of Exchange

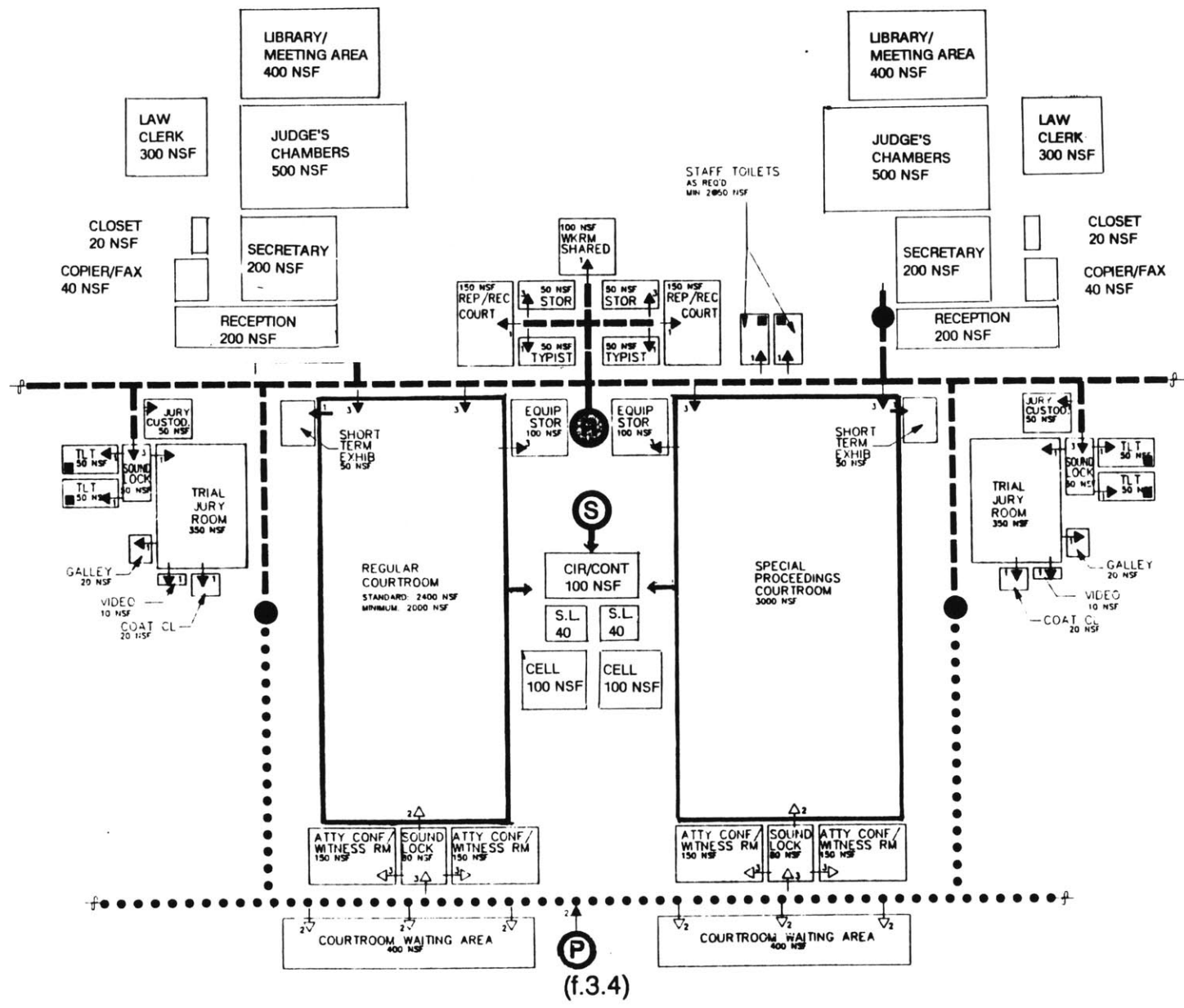

3.1.2 Vertical Zones of Exchange

The ground level of the courthouse building will attract large numbers of the public. Their use of the lower floors will reduce the demand and requirement of elevators; escalators will be utilized instead for shorter connections between ground to lower floors. This vertical interchange of space is critical to avoid peak loads during rush hour. High volume offices can be placed on lower levels.



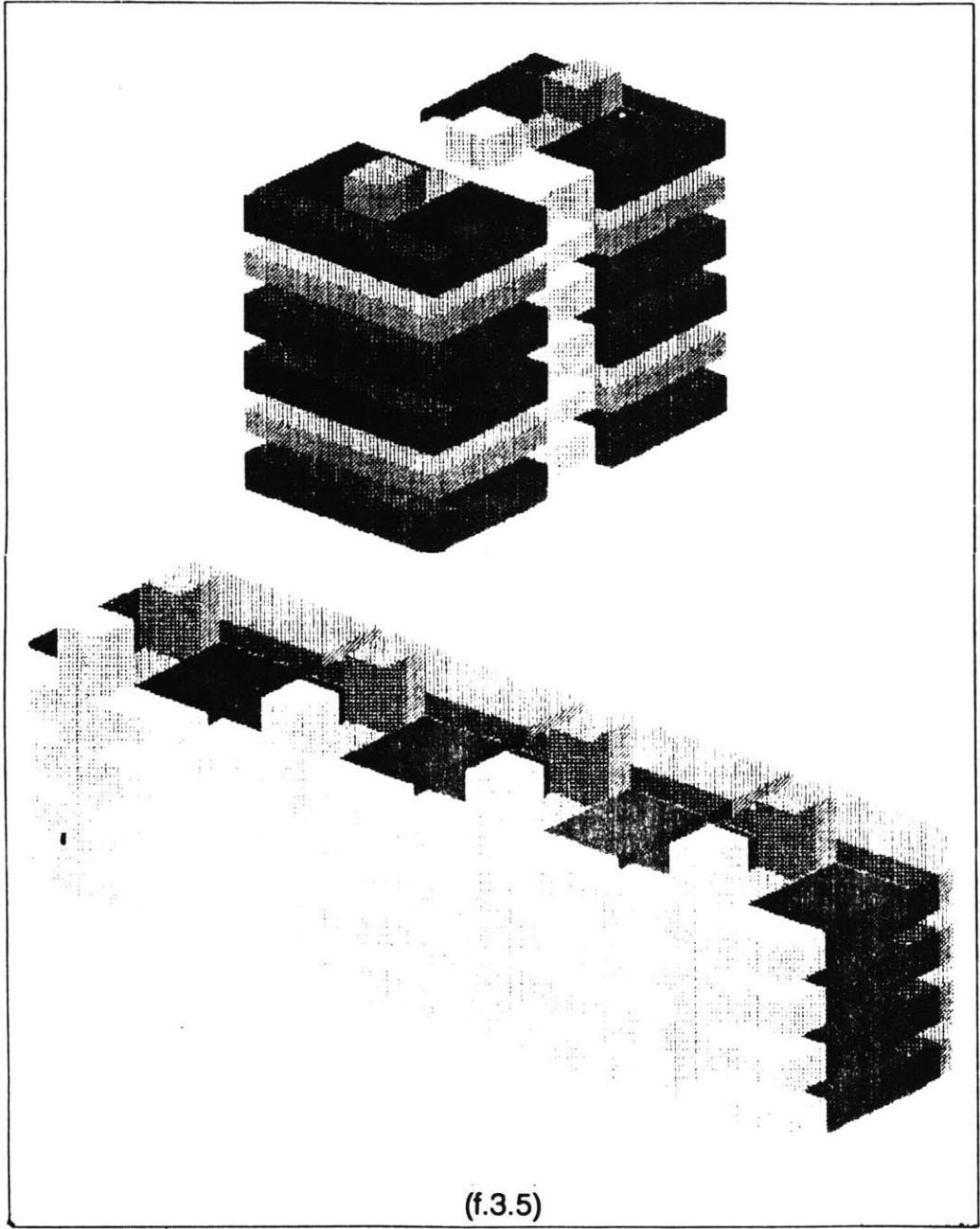

Proper vertical placement of the courtrooms in relation to access routes will ensure that individuals with specific court-related business can reach the courtroom floors easily. This placement, in turn, expedites elevator traffic and accommodates opportunities for privacy in the courtroom spaces without interfering with normal activities in other building areas.

The spatial requirements of the program can be clustered with two, four, or eight courtrooms on each floor, which will yield the height, width, and depth of the building, and the manner in which will be accommodated in this project. The generic clustering scheme is explored in (f.3.5). Two courtrooms per level appear to be the minimum for the high rise tower. Two separate possibilities of "two-courtrooms-per-floor" shown in (f.3.5) demonstrate the layouts of this arrangement. These can be organized with judges' chambers on the same or intermediate levels. A similar arrangement can be considered when four courtrooms per level can be organized in linear or central configurations. Eight courtrooms per level will yield a much lower building, requiring shorter vertical access, but a more extended horizontal access system.



Vertical Zones of Exchange

Four courtrooms per floor with chambers on the same floor.

-  *Public circulation*
-  *Courtrooms*
-  *Chambers/private circulation*
-  *Jury deliberation rooms*
-  *Prisoner circulation/holding*

Paired courtrooms with chambers on the same floor organized in a linear fashion, four, six, eight, ten, etc. courts per floor.

(f.3.5)

Various possibilities for the generic organization of the typical courtroom components of the program. In each case a clear separation of public, private, and secure circulation systems is achieved.

Two courtrooms per floor with chambers on intermediate floors.

Two courtrooms per floor with chambers on the same floor.

Four courtrooms per floor with chambers on intermediate floors.

Vertical Zones of Exchange

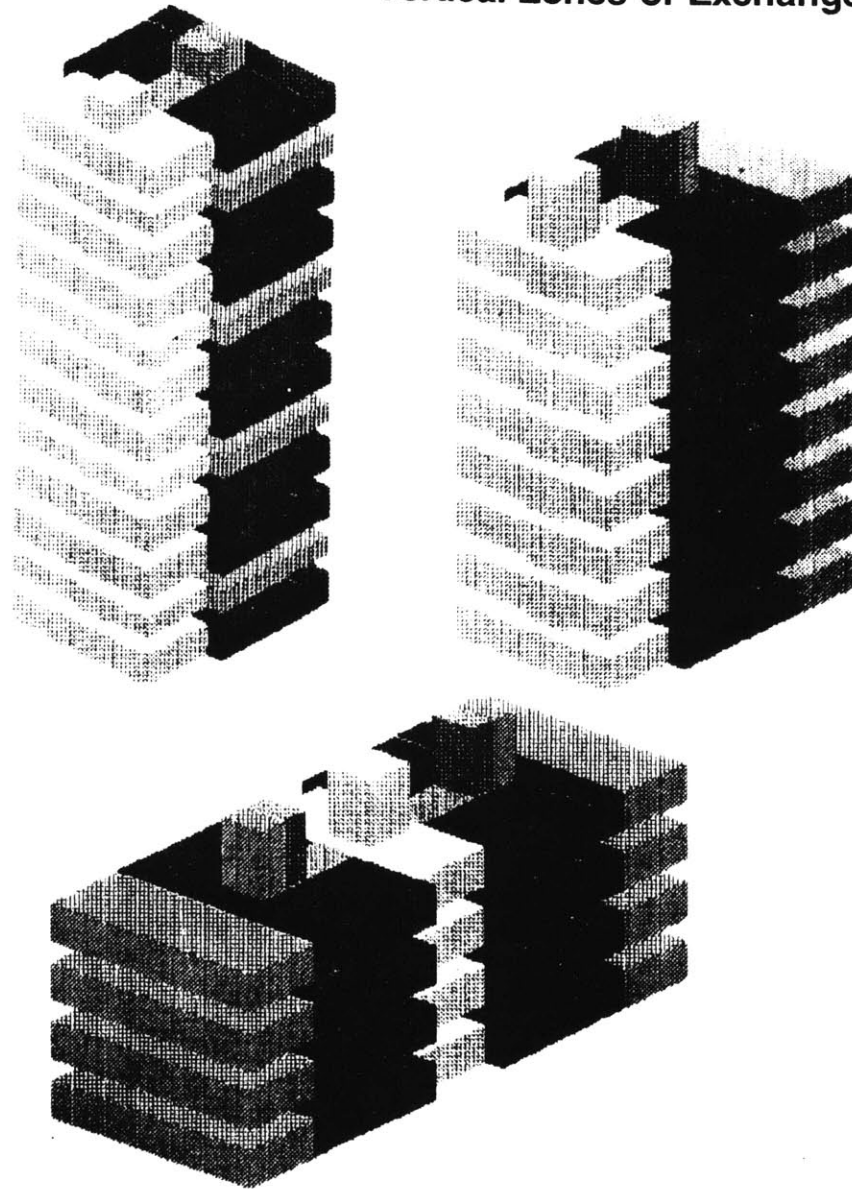

3.2 Courthouse Spatial Uses

The courthouse staff is composed of several user categories: judges, clerical staff, administrative staff, departmental employees, marshals, probation, pre-trial, bureau of prisons, and attorney spaces. These user groups occupy office space, both public and private.

3.2.1 Use Plan Layouts

Office Space, particularly for the clerks, should be business-like and efficient. Natural light is desirable. A sense of human scale in the spatial layout is also important.

Meeting Areas for conferences should be approximately 600 square feet and should hold a conference table.

Toilet Groups will be prefabricated off-site and installed as an entire unit on-site.

Waiting and Relaxing Areas will be used by jury assembly between deliberations as well as visitors and attorneys for the purpose of social interaction.

Restaurant Areas will be accessible to everyone inside the courthouse building. (fig. 3.6)

Private offices for the various spaces should have natural light. Providing daylight for every work space in the courthouse is a necessary objective. Furthermore, acoustics are important to strengthen a sense of privacy from office to office. In addition, judges' spaces are a private component of the courthouse.

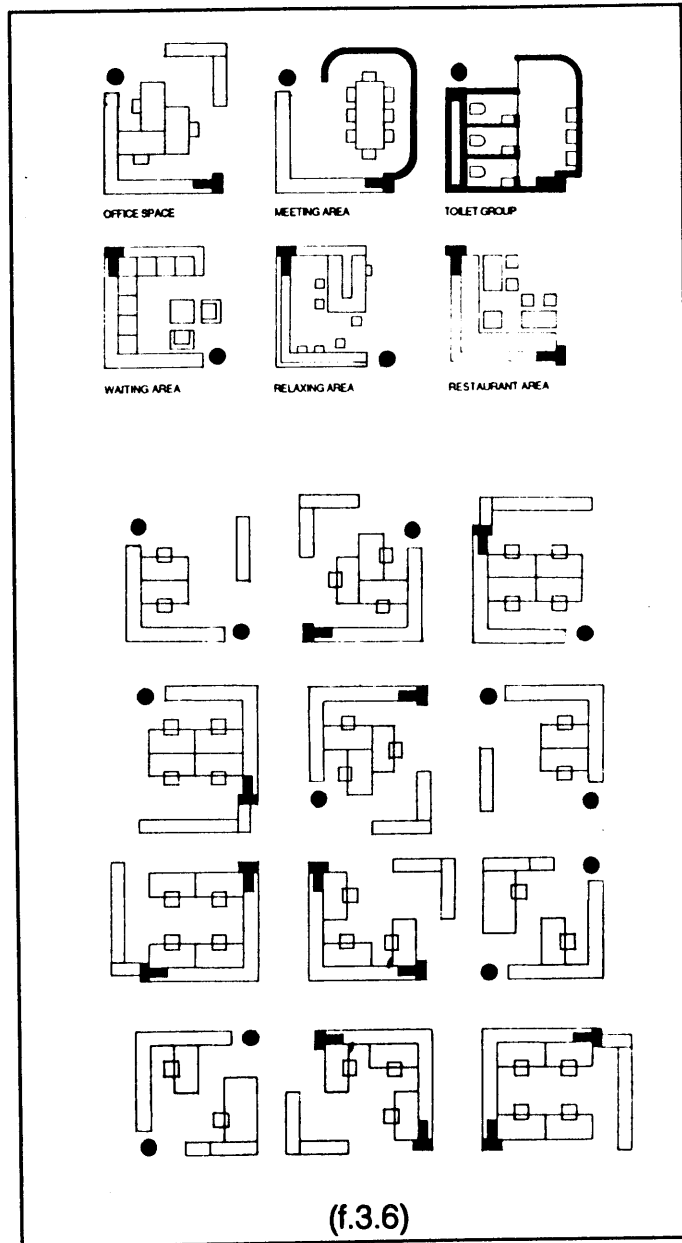

Section 4 Building Systems Analysis

The basic structure is the bearer of the whole complex, it comprises the major building systems and coincides with the principal access routes inside the complex.¹⁵

The building structure manifests itself as two structural systems: first, as a primary structural system that continues along the periphery of the site, and second, as a secondary structural system. The primary structural system in the courthouse building is composed of five separate primary systems (f.4.1). The secondary structural system bridges the primary systems and also extends out to form the basic configuration of the building.

Each of these separate primary building systems will be adjacent to a number of secondary structural building systems, each of which is directly accessible from the central access zone located in the primary structural system (f.4.1). These secondary spatial zones contain the general facilities of the buildings, staircases, lifts, switchboards, conduct shafts, air ducts, and maintenance closets. These facilities are located at regular distances from one to the other throughout the building complex, resulting in a constellation of vertical supports which, on the construction level, serve as a lateral stabilizing function within the complex as a whole. These fixed points of support are made of secondary prefabricated elements.

¹⁵ Herman Hertzberger, 'Buildings and Projects' 1959-1986, Den Haag, A. Lchinger, 1987, p.39.



Primary Structural System

Secondary Structural System

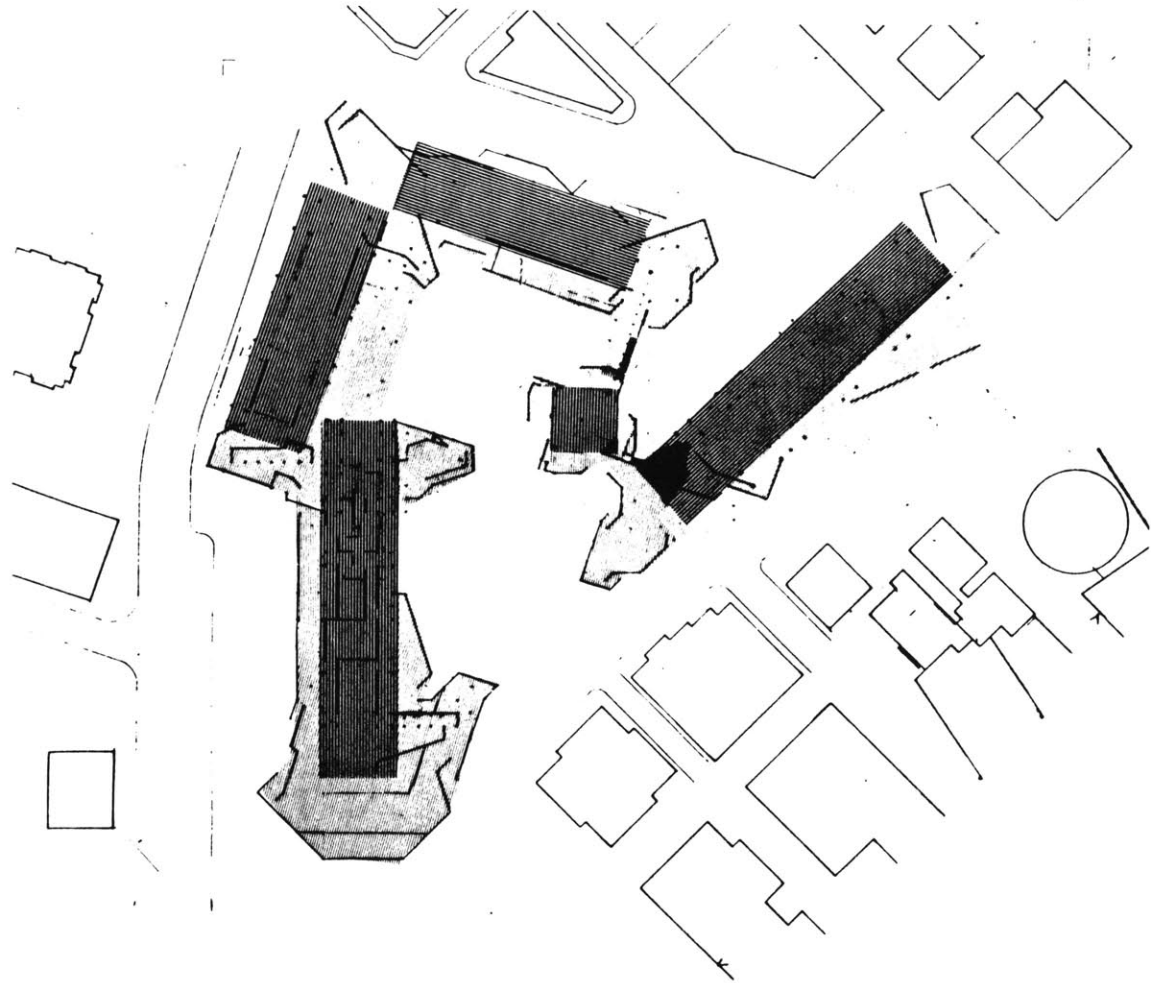

(f.4.1)

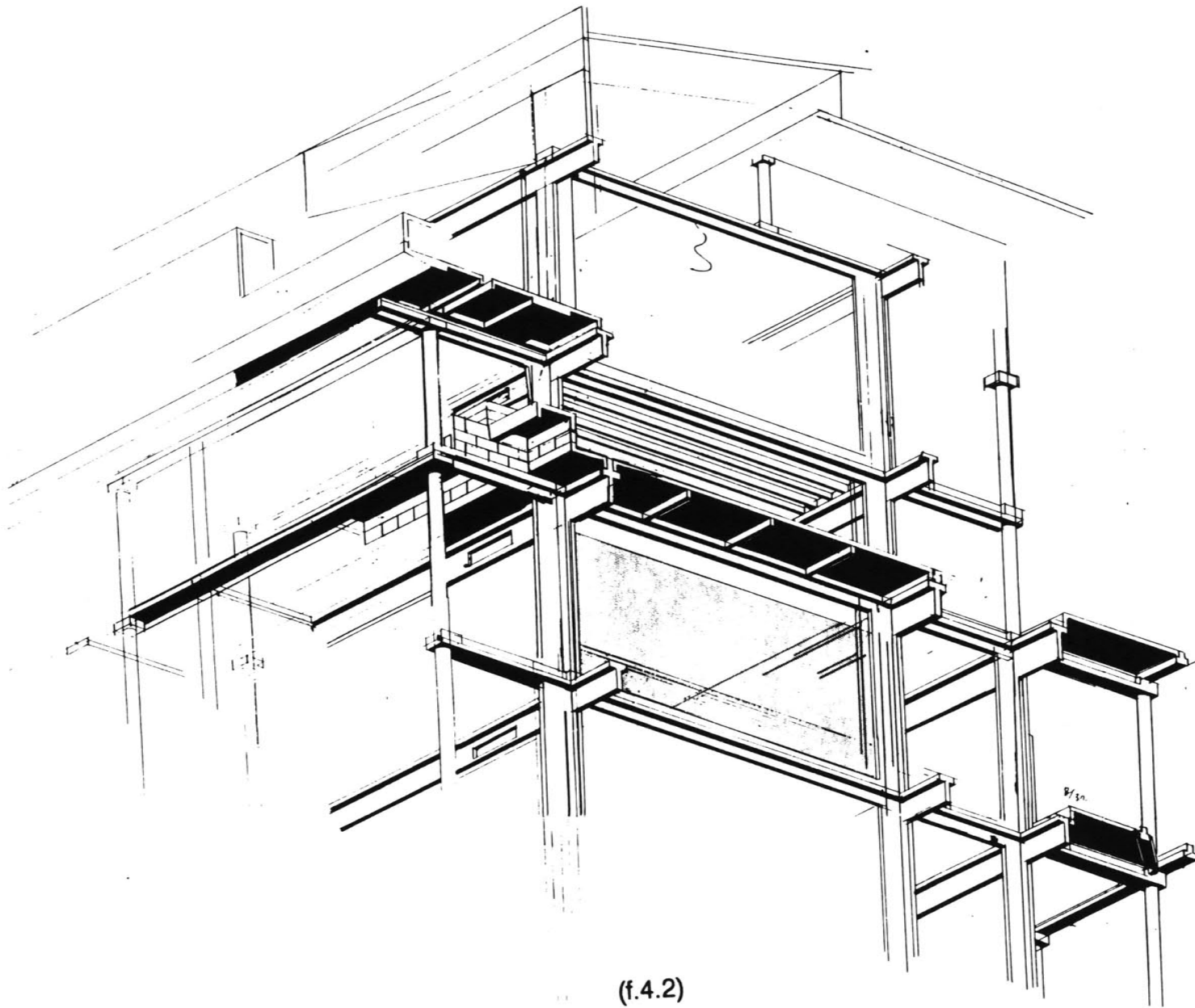

(f.4.2)

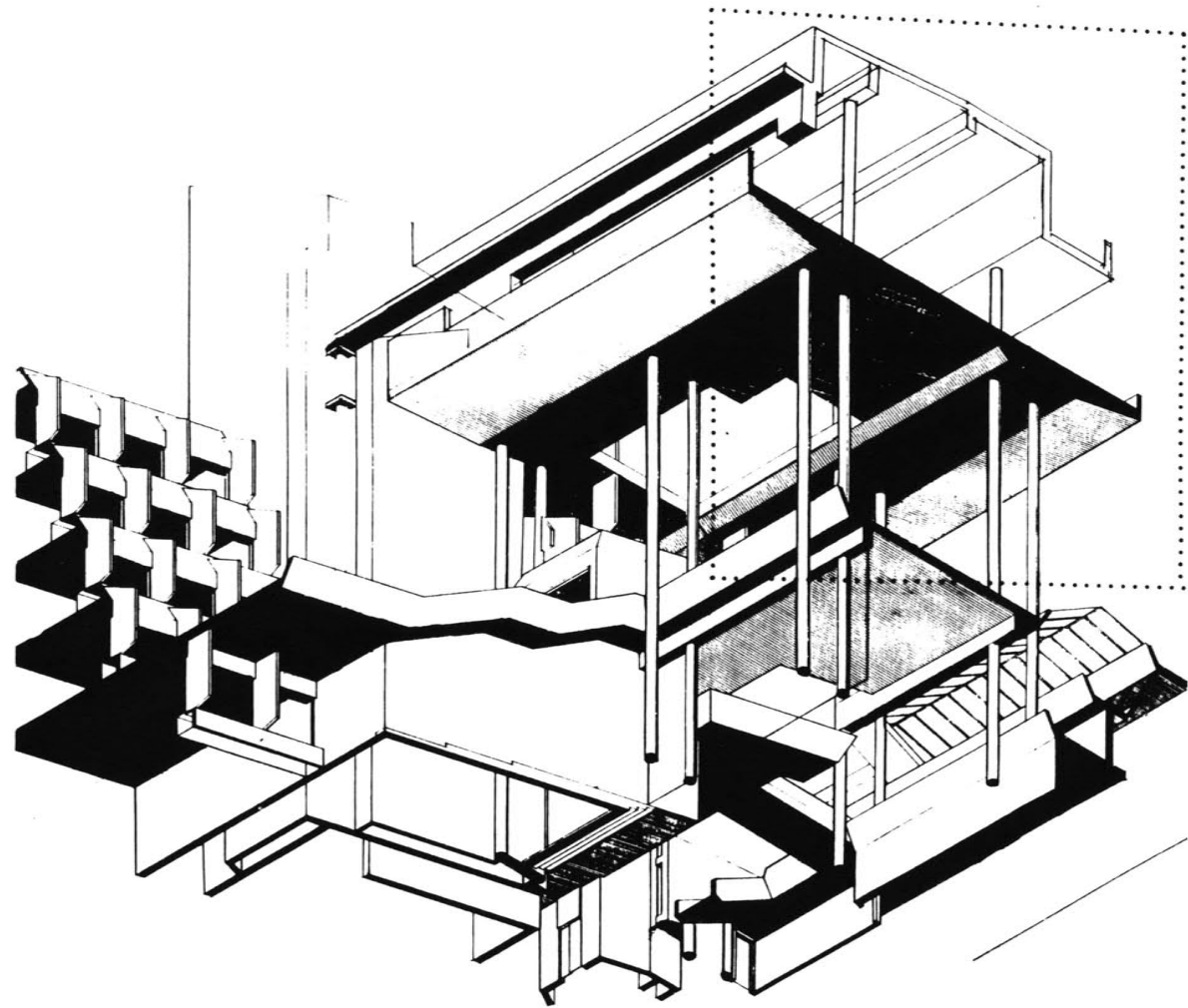

(f.4.3)

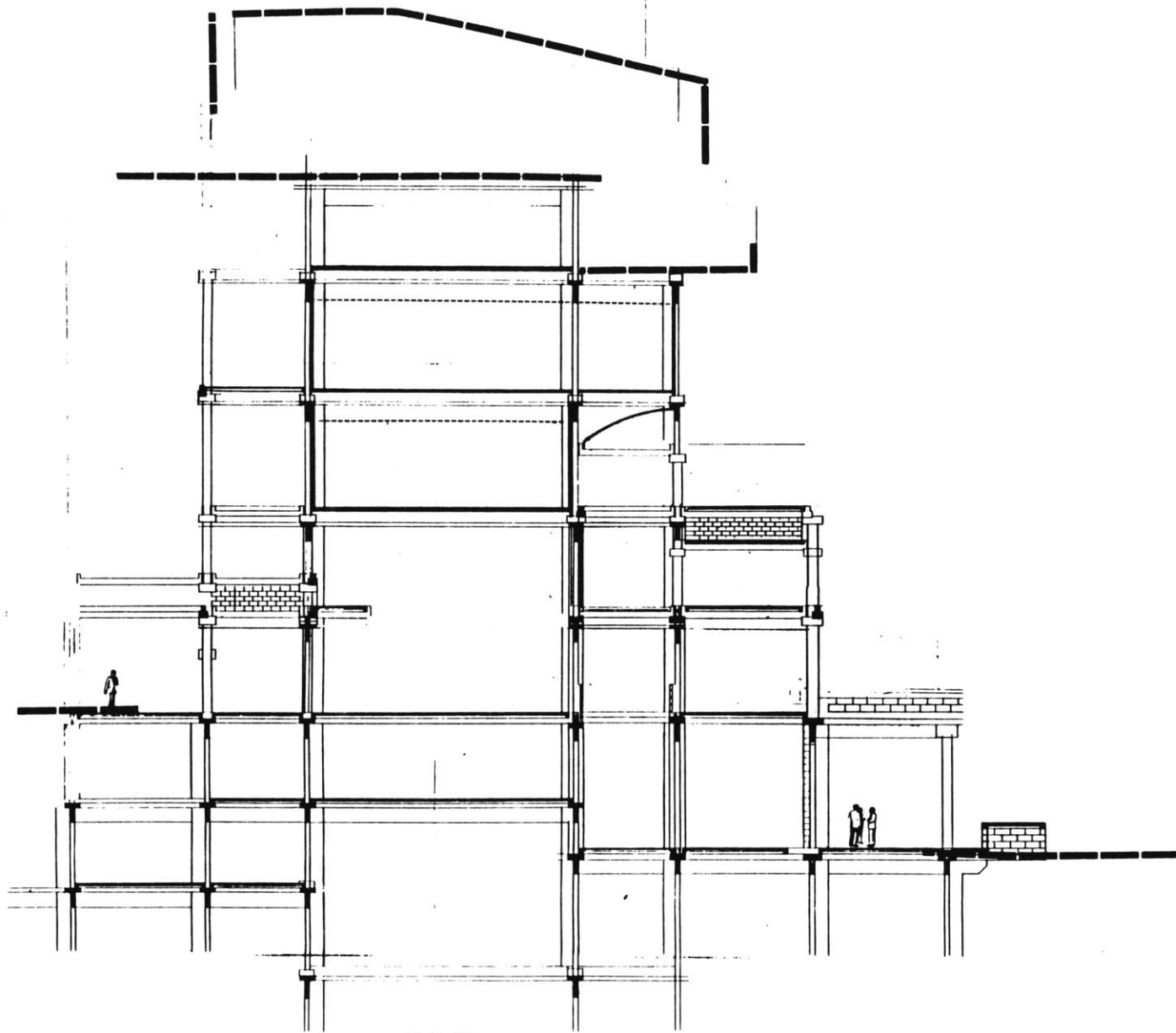

(f.4.4)

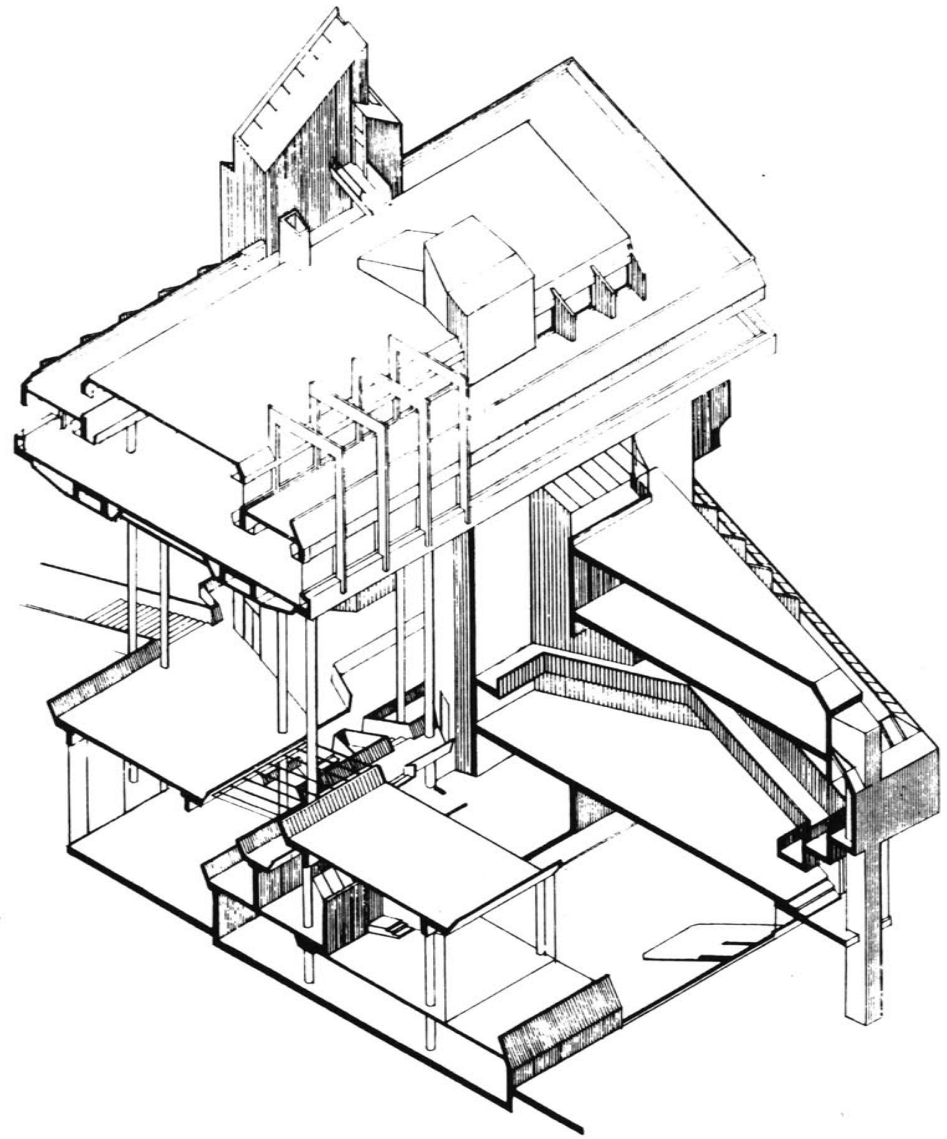

(f.4.5)

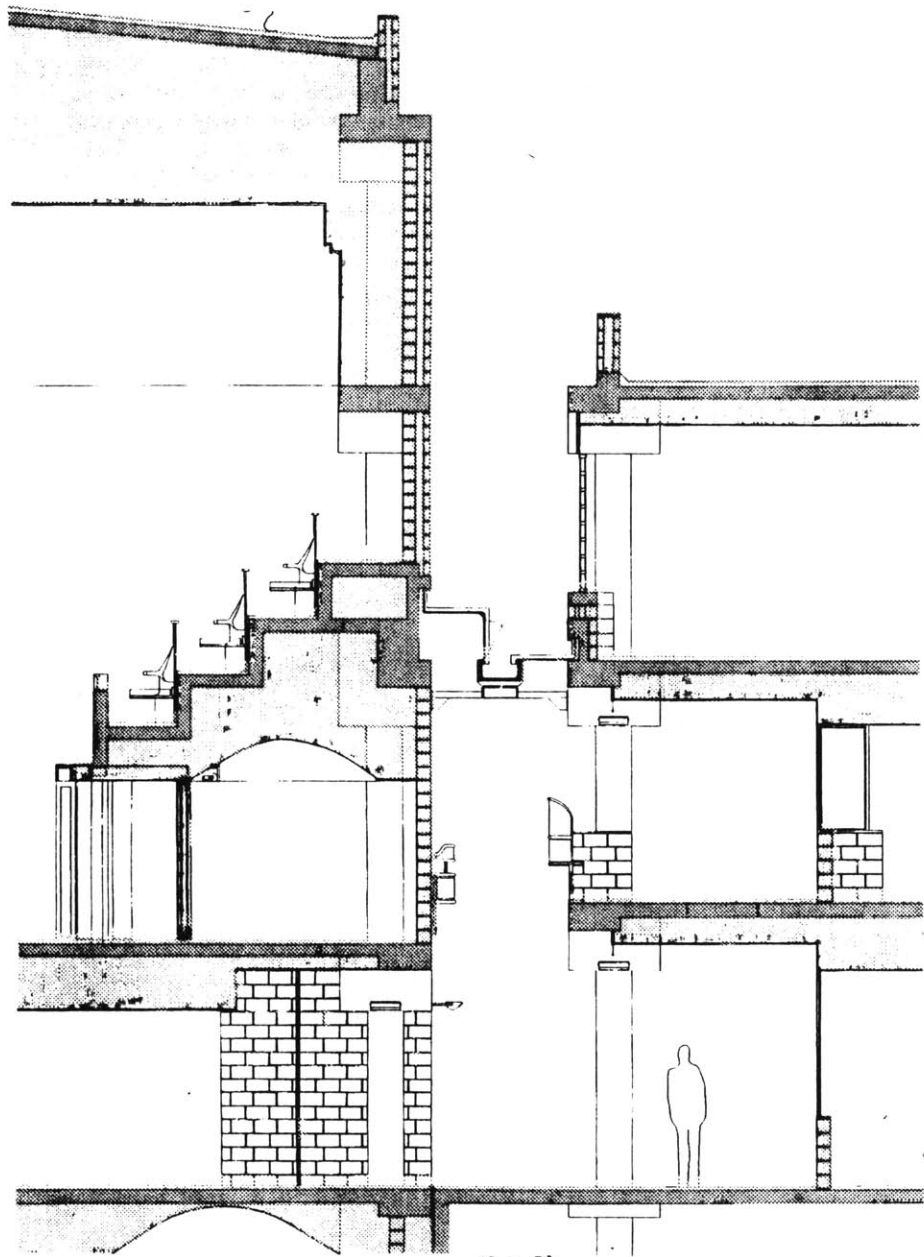

(f.4.6)

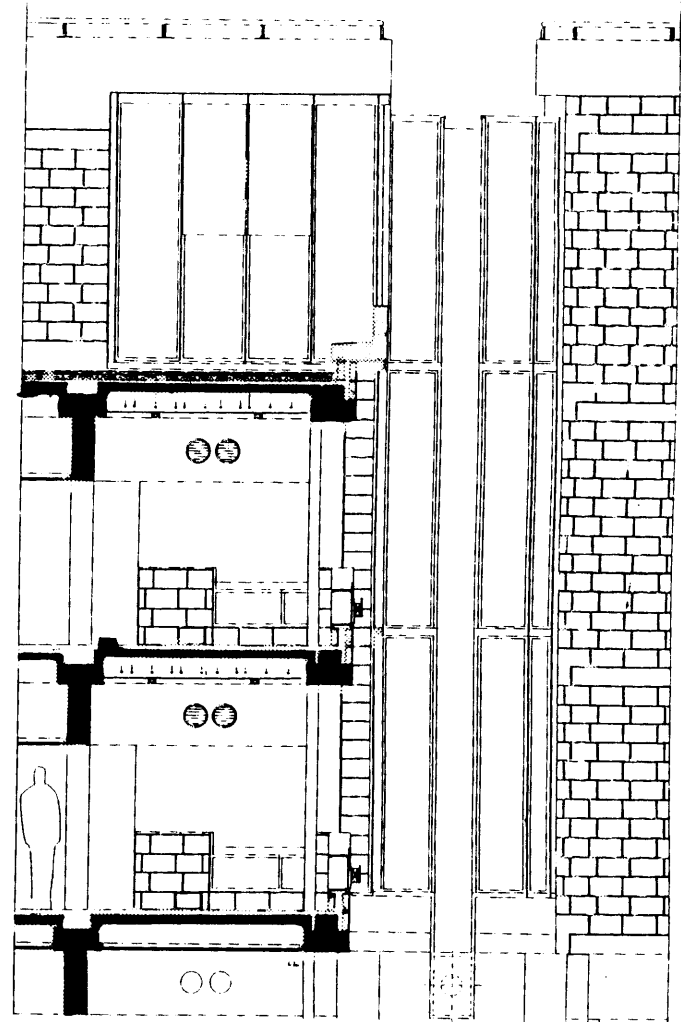
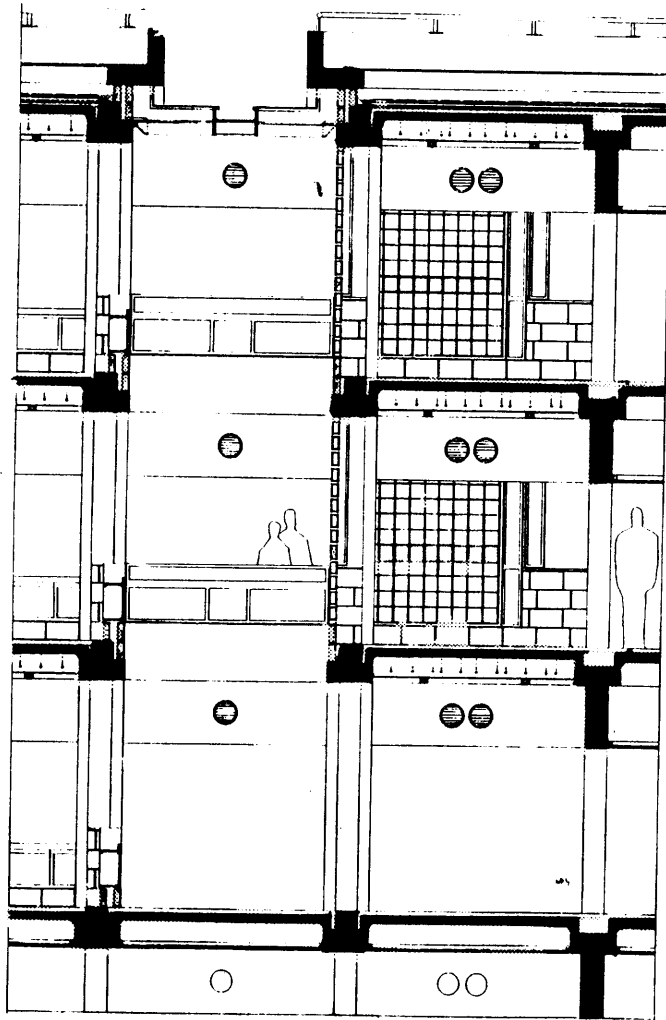

(f.4.7)

4.1 Structural Elements

*'The individual building components should be autonomous in order to assume various roles, while the form of the component must be chosen in such a way that the different building elements are constantly attuned to one another.'*¹⁶

The chosen design process is an attempt to make each element legible, both in the sense of independence and in its relation with other elements as part of a larger structure, (f.4.8) i.e. by letting each element express itself as to how it functions in the larger whole of the complex. Details become an important factor when this legibility of elements comes into play.

By disassembling the structural elements, we can see how they were woven together forming the whole. Isometric drawing (f.4.9) illustrates how these elements are joined together at intersections making the structure as a whole speak one tectonic language.

¹⁶ Herman Hertzberger, 'Buildings and Projects', 1959-1986, Den Haag, A. Lchinger, 1987, p.39

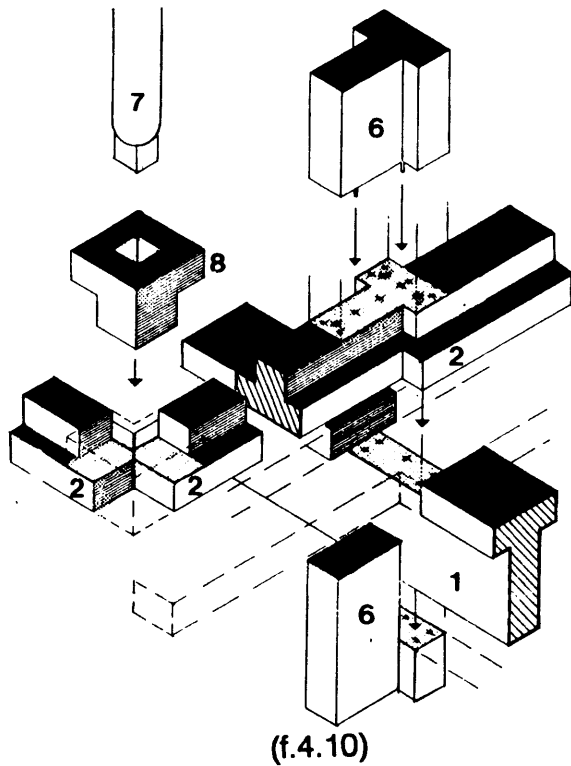

The building as a whole derives its identity from the complex of different interpretations by its users, while the whole is represented in these elements. The way in which elements are assembled leads to individual elements becoming more and more visually independent; they are freed from the rest of the system and given their own identity by virtue of the different ways in which these elements are assembled at intersections (f.4.10).

*'The building elements should be unique from one another and should remain the same in all conditions throughout the system. Moreover, they should be capable of contributing to the identity of the greater whole of which it forms a part. In this case, the use of prefabricated components is not a consequence for the need of repetition, but the desire to individualize each element.'*¹⁷ The decision to adopt a system whereby prefabricated components can be assembled on the building site should also represent a considerable reduction in cost.

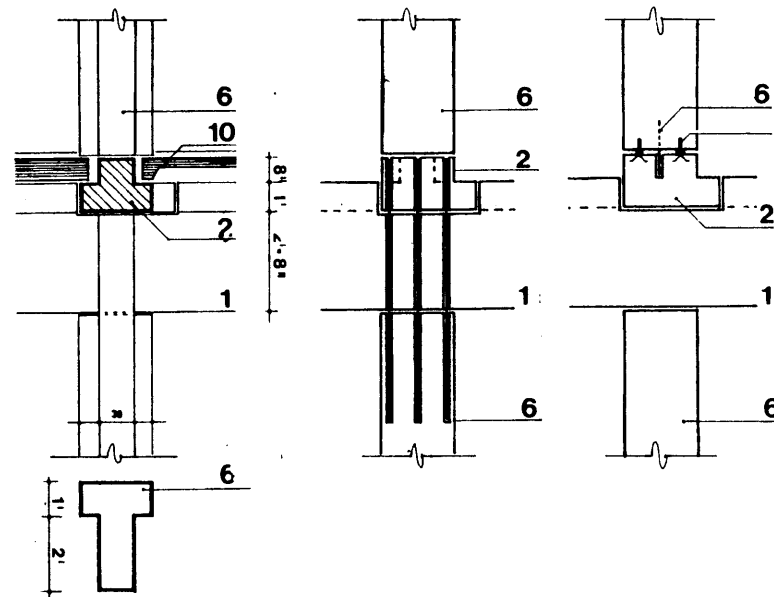

¹⁷ Herman Hertzberger, 'Buildings and Projects', 1959-1986, Den Haag, A. Lchinger, 1987, p.39.

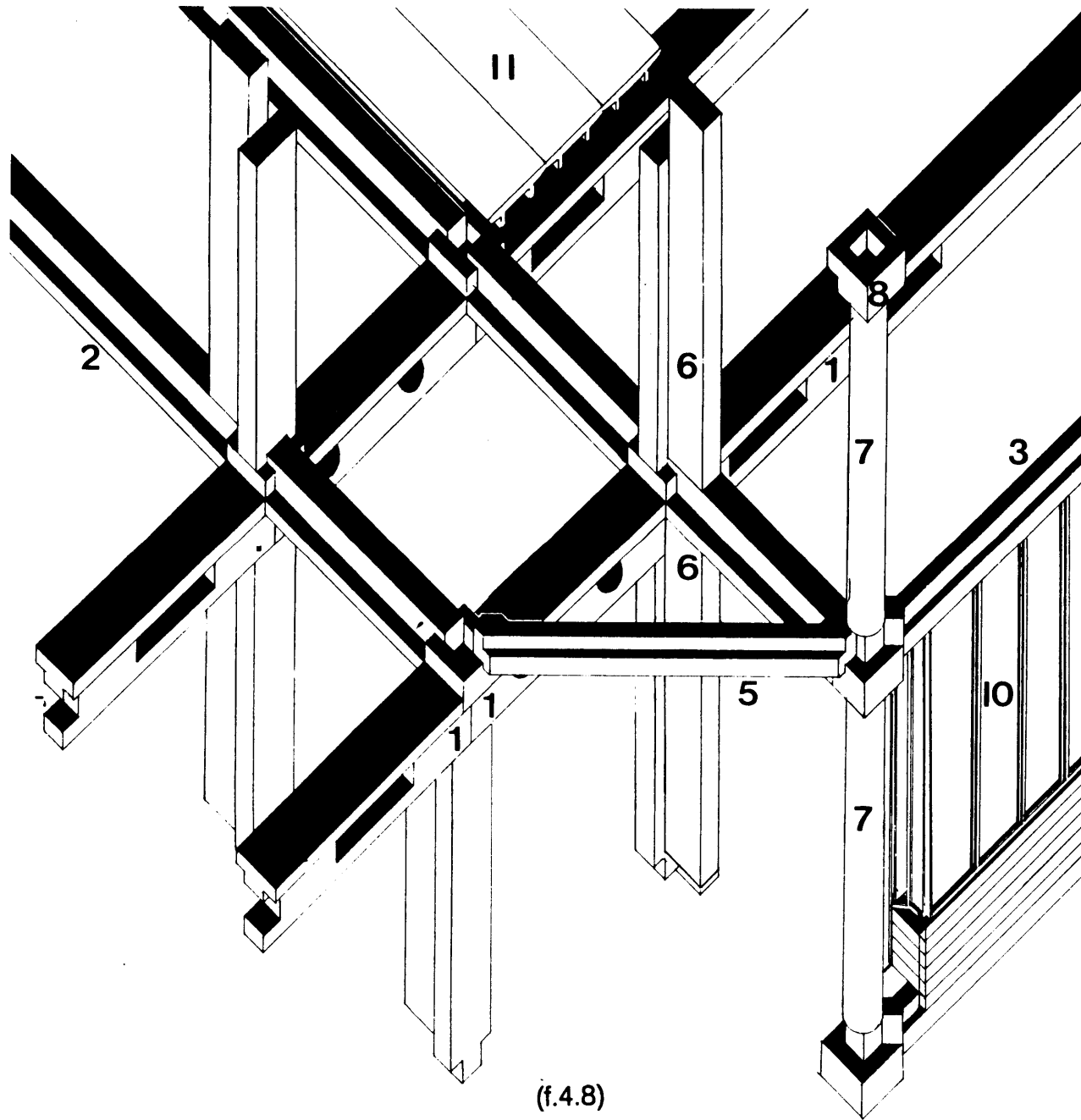

(f.4.8)

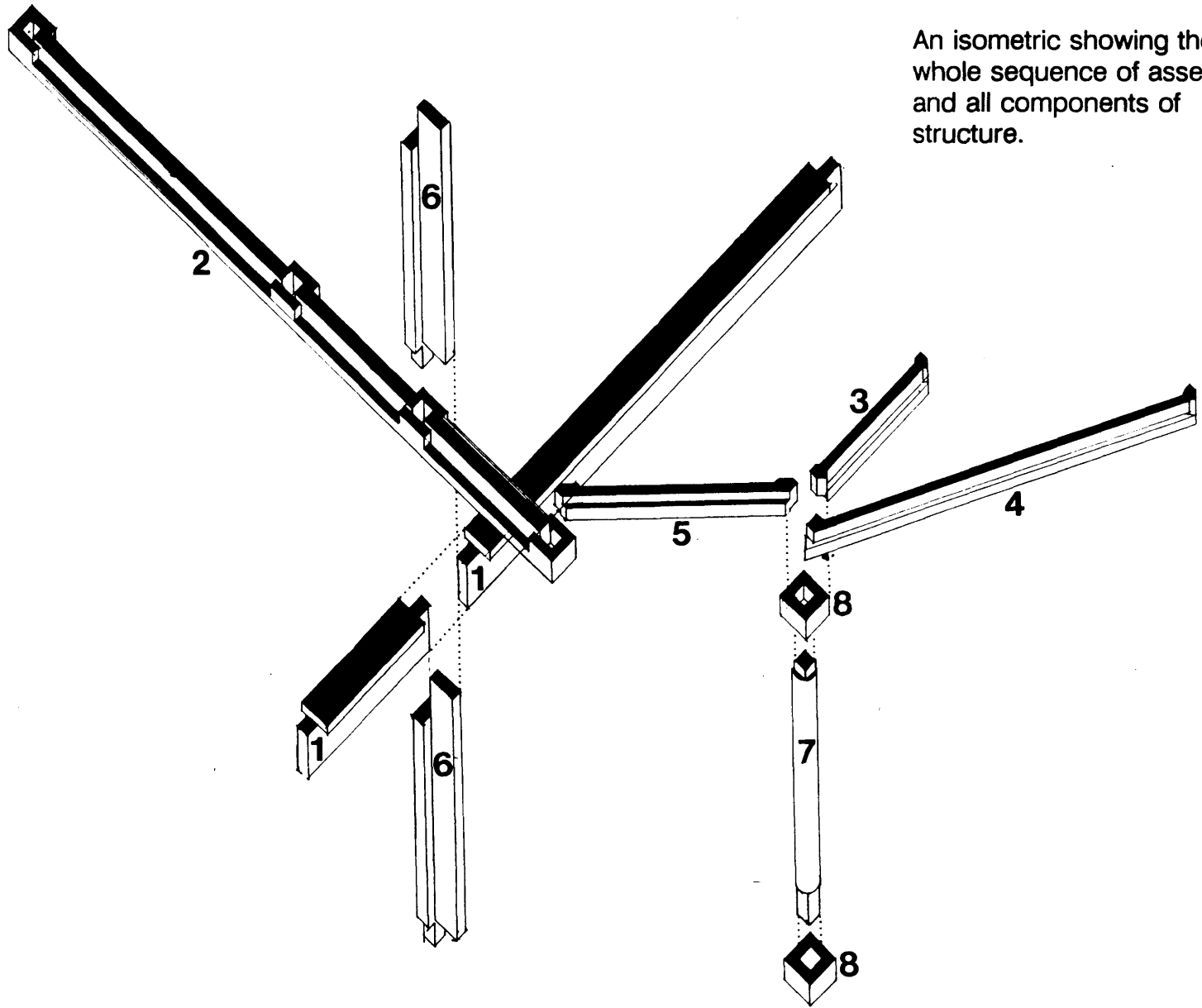

An isometric showing the whole sequence of assembly and all components of structure.

(f.4.9)

The secondary structural columns in the front of the building (f.4.11) serve to keep the walls at a greater or smaller distance apart, depending on the amount of glazing that is required at a specific location. The openings at the building facade are sometimes located in the column zone; rarely do these columns occur as holes in the walls.(f.4.12) The columns standing freely in the spaces enveloping them constitute a motif which recurs in variations throughout the building, and yield a recognizable and characteristic image.

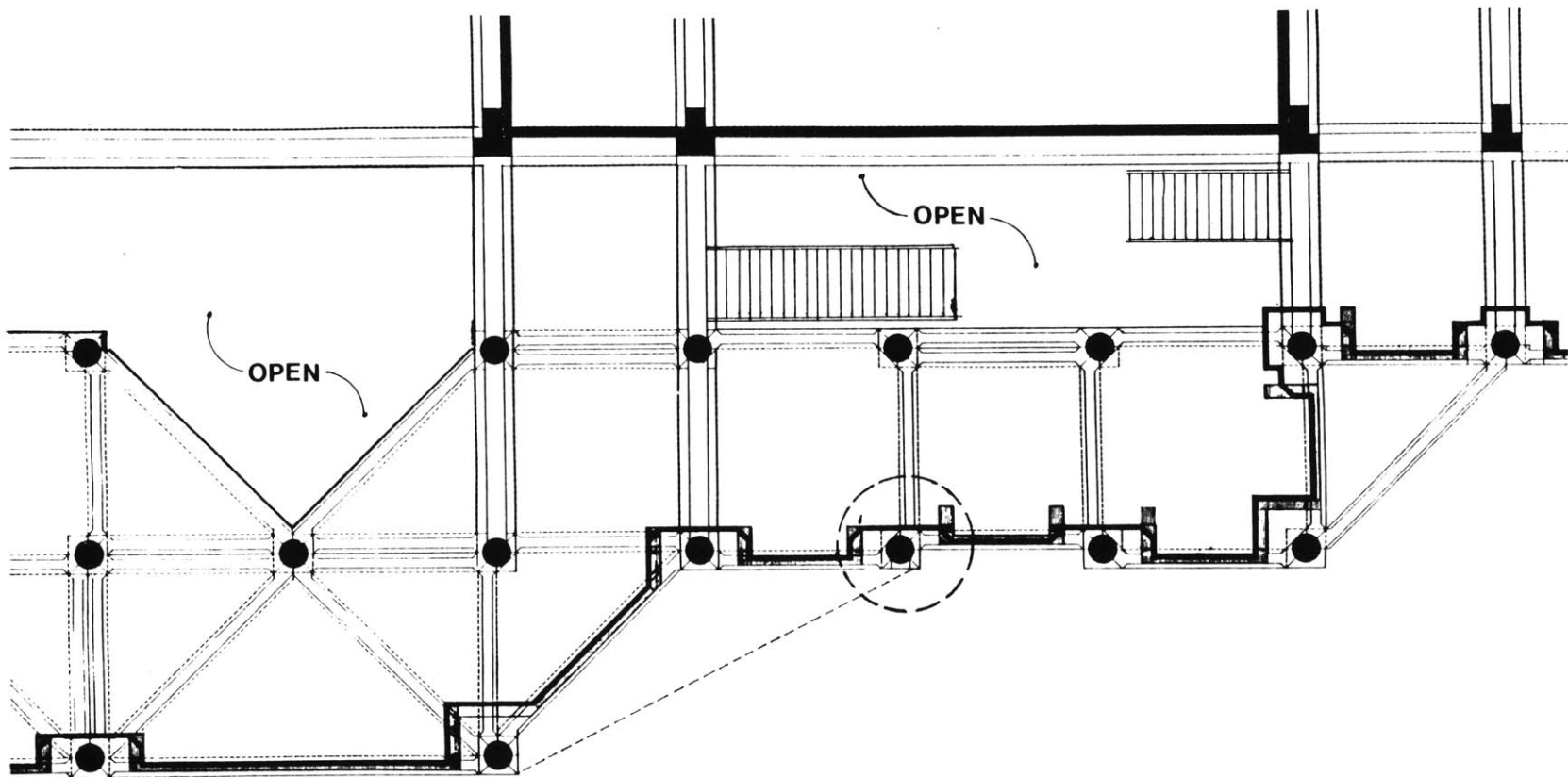

(f.4.11)

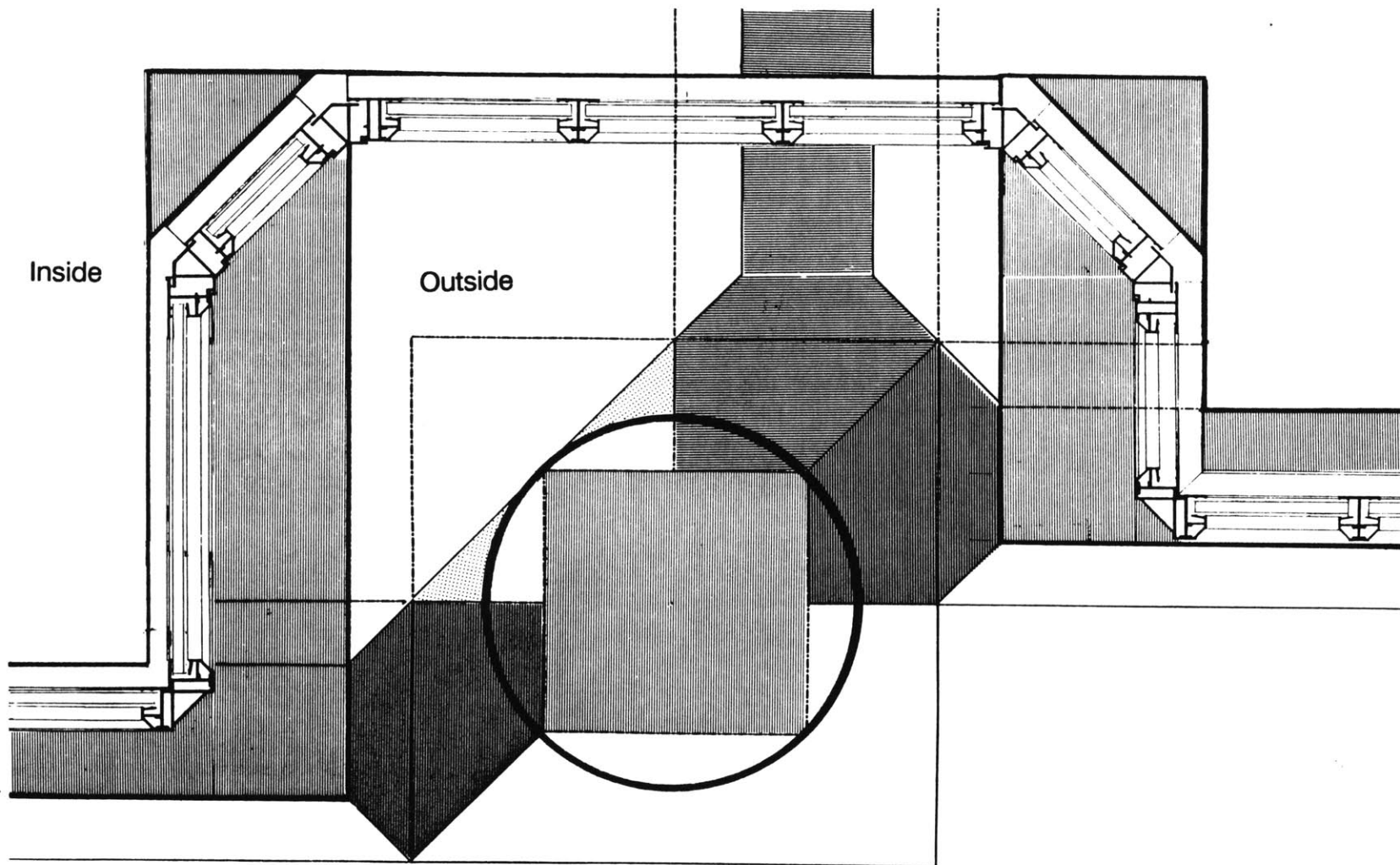

(f.4.12)

4.2 Catalog of Parts

The structural system should represent a rationalized and dimensionally coordinated "Catalog of Parts", which will be precast off site, used either as a complete set, or selectively.

4.3 Beams

The objective of primary and secondary beams is to have them assembled in such a way that they would ensure a continuous lengthwise definition of structure.

4.3.1 Primary Beams

The primary beams are parallel (f.4.13) and perpendicular (f.4.14) with respect to the direction of the building as it conforms to the perimeter of the site. As part of the technical installations for the courthouse rooms, the primary structural beams should have openings (f.4.13) for conduit shafts, to be wholly integrated into the prefabrication of these primary beams.

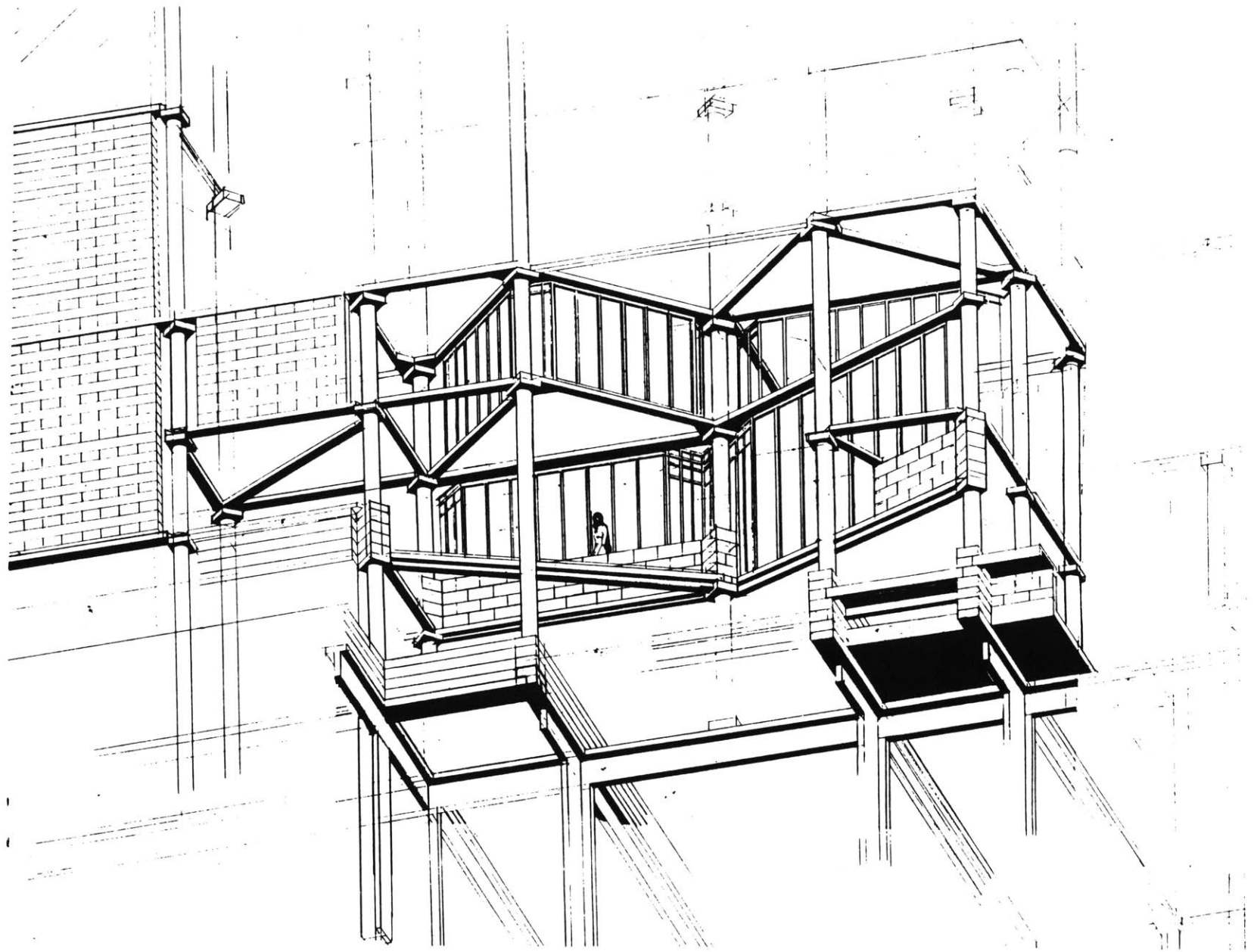

Primary structural beams with large 24" x 2'-0" openings for HVAC penetration.

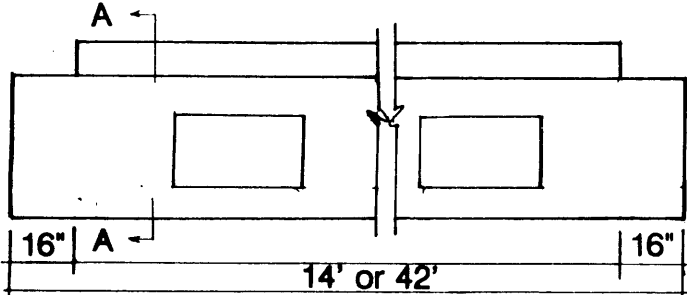

Elevation

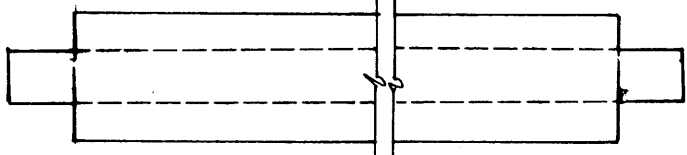

Plan

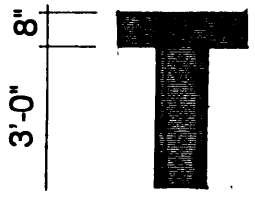

Section A-A

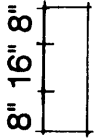

(f.4.13)

1

Primary structural beams
that makes the connection to
the secondary structural system.

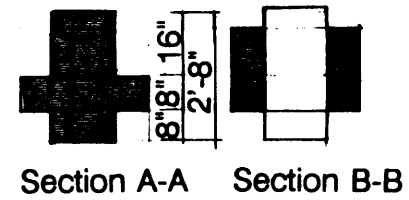
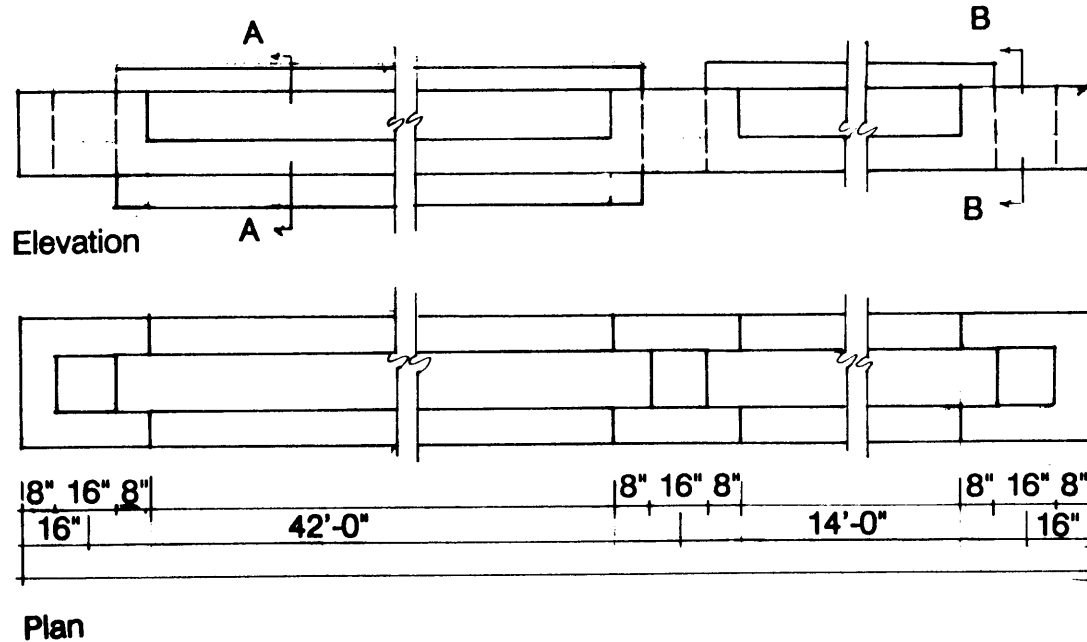

(f.4.14)

2

4.3.2 Secondary Beams

The secondary beams -- in spite of their lighter size -- perform an important function from a spatial point of view, for these secondary elements offer more flexibility, both in terms of overall layout and shape, and internal distribution of space than the primary structural elements. (f.4.15)(f.4.16)(f.4.17).

Secondary structural beams
most widely used throughout
the system.

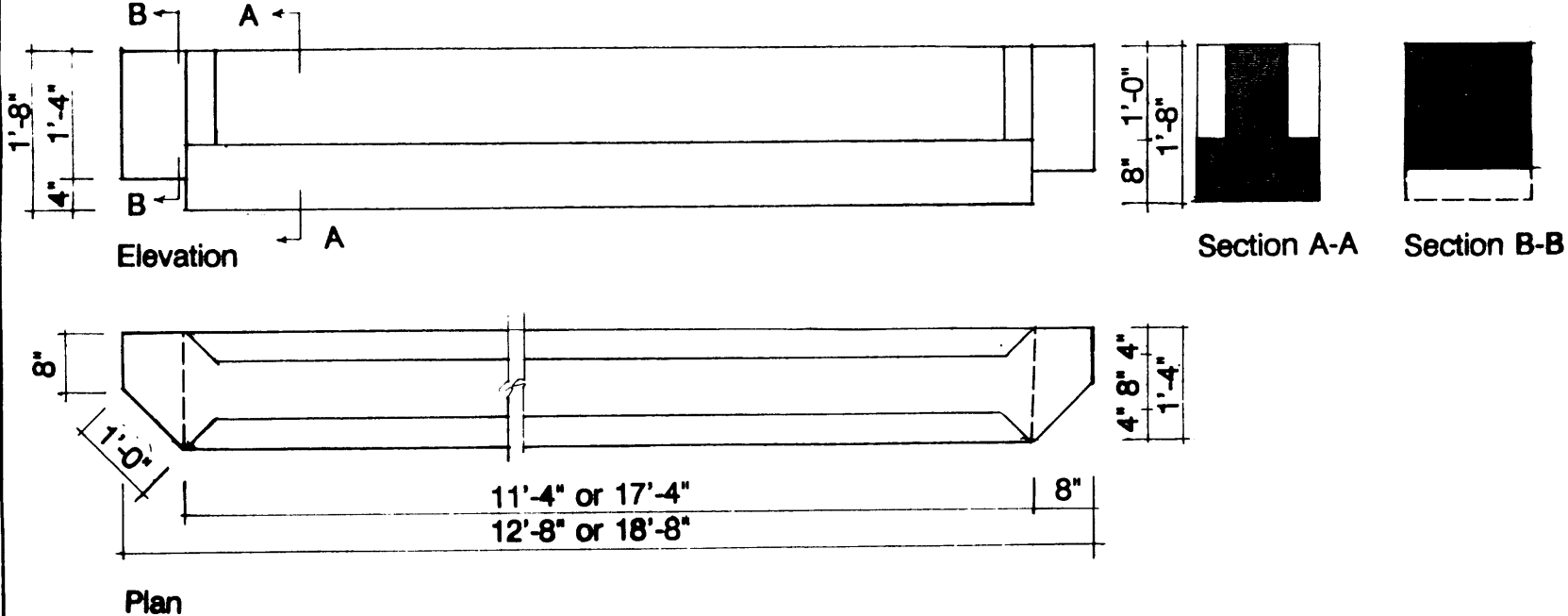

(f.4.15)

3

Secondary structural beams
used for a 27.5% diagonal.

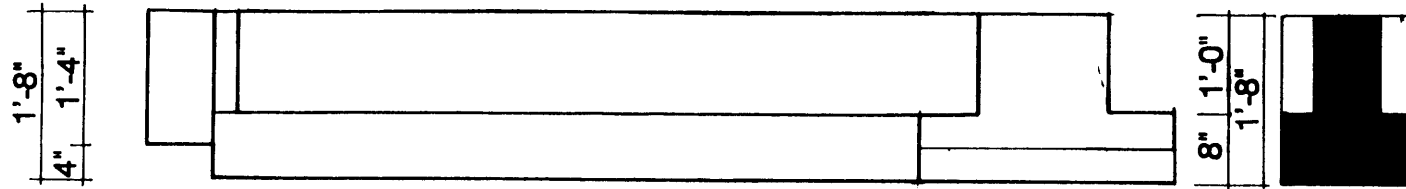

Elevation

Section A-A

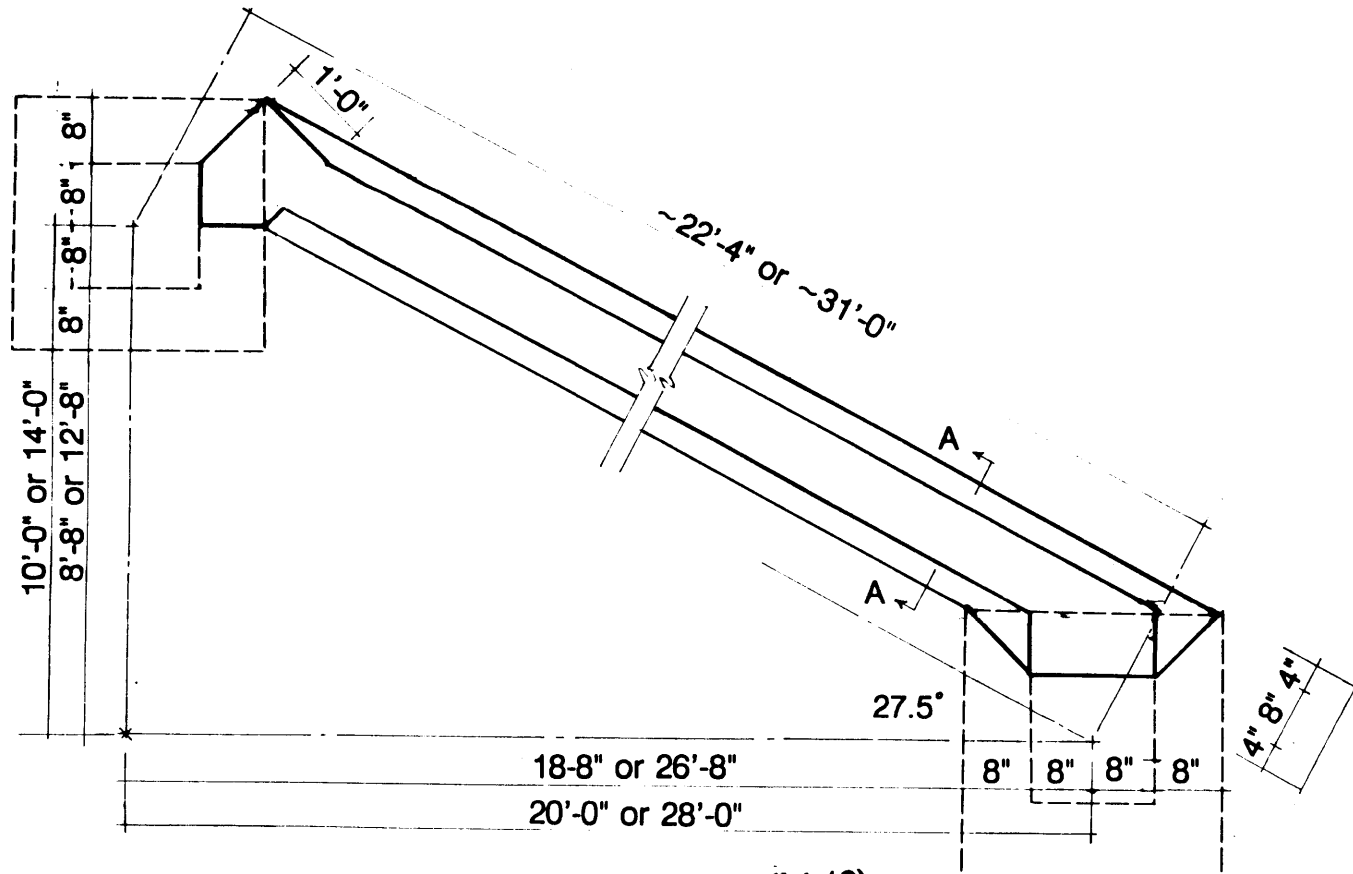

(f.4.16)

4

Secondary structural beams
used for a 45% diagonal.

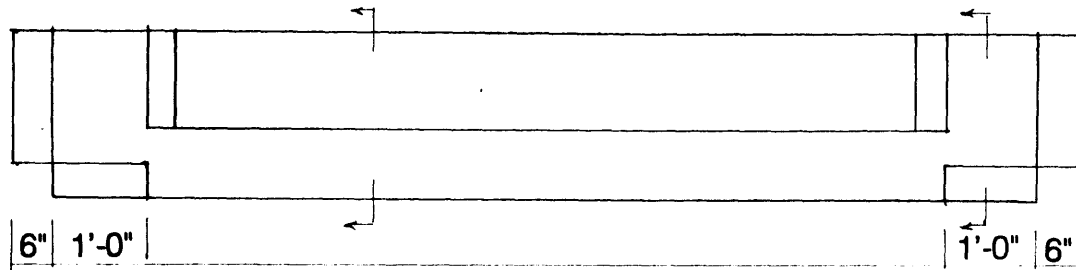

Elevation

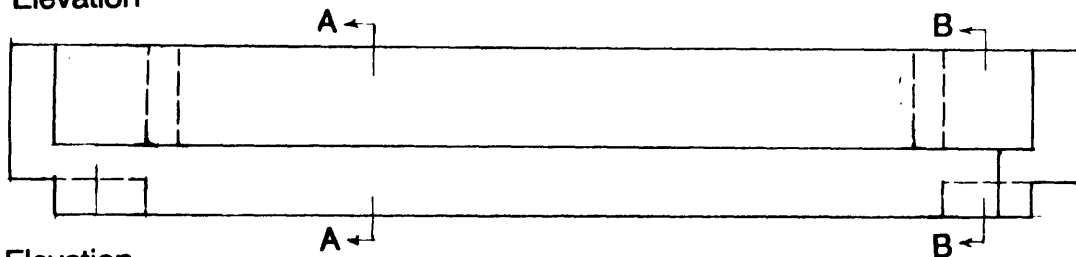

Elevation

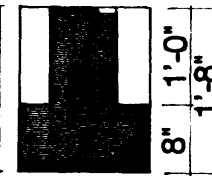
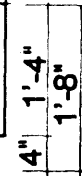

Section A-A

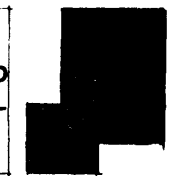

Section B-B

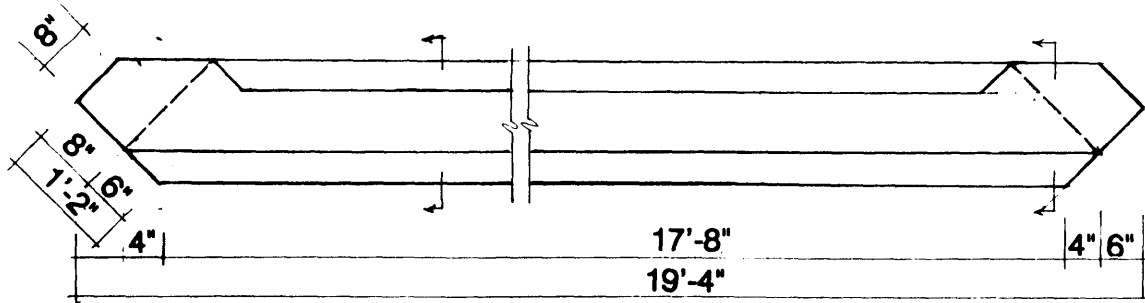

Plan

(f.4.17)

5

The flooring elements of the secondary structural system may be left open in places by not introducing floor panels between prefabricated floor parts terminated by secondary beams.(f.4.18) An advantage of this building technique is the quality of the finish is to permit total exposure of the prefabricated components. that could be obtained. The beams resting on the column heads should have a projecting ridge serving at a later stage as a simple attachment for prefabricated floor panels.

Plan diagram (f.4.19) illustrates all of the possible variations of the secondary structural beams in relation to the secondary structural columns. Each beam is coded with a specific shade representing the different prefabricated beams in the catalog of parts.

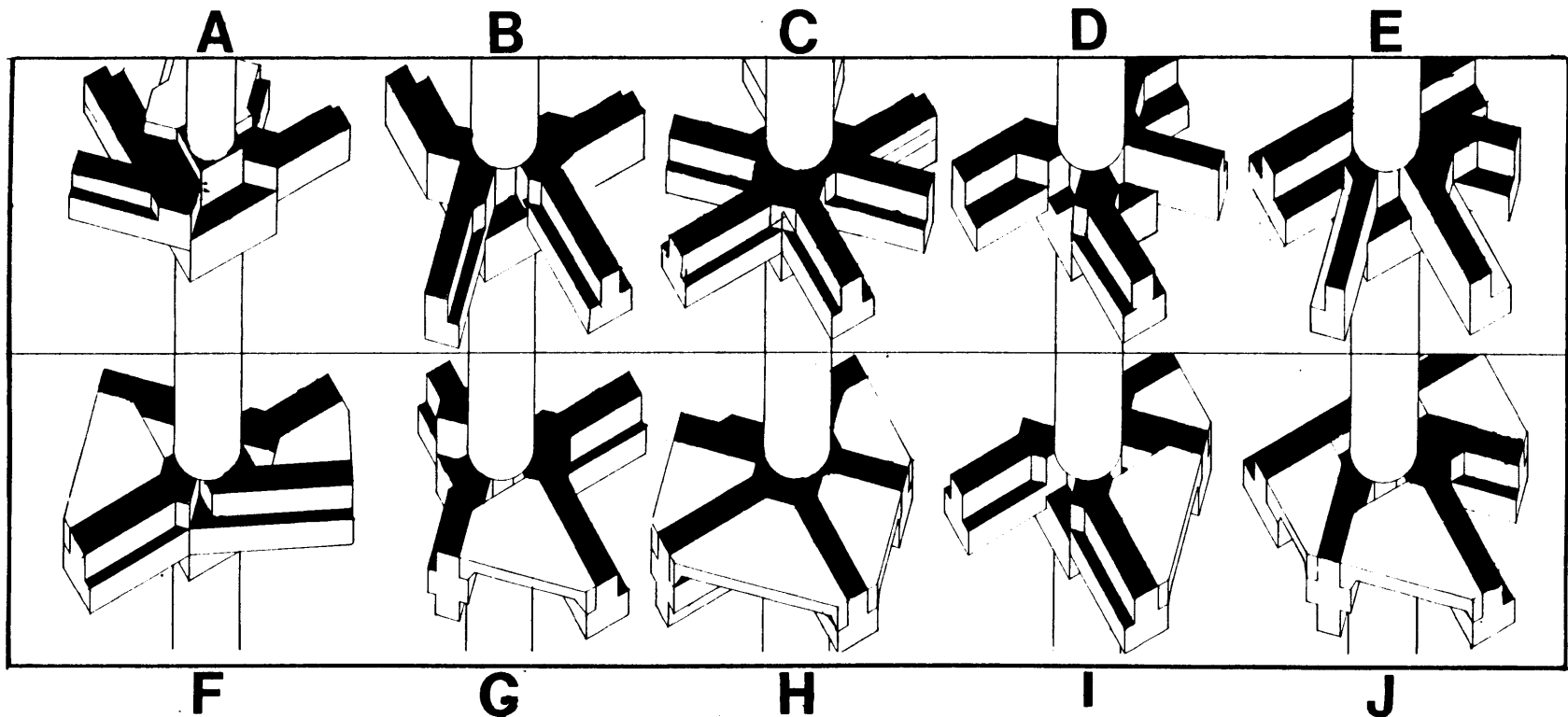

(f.4.18)

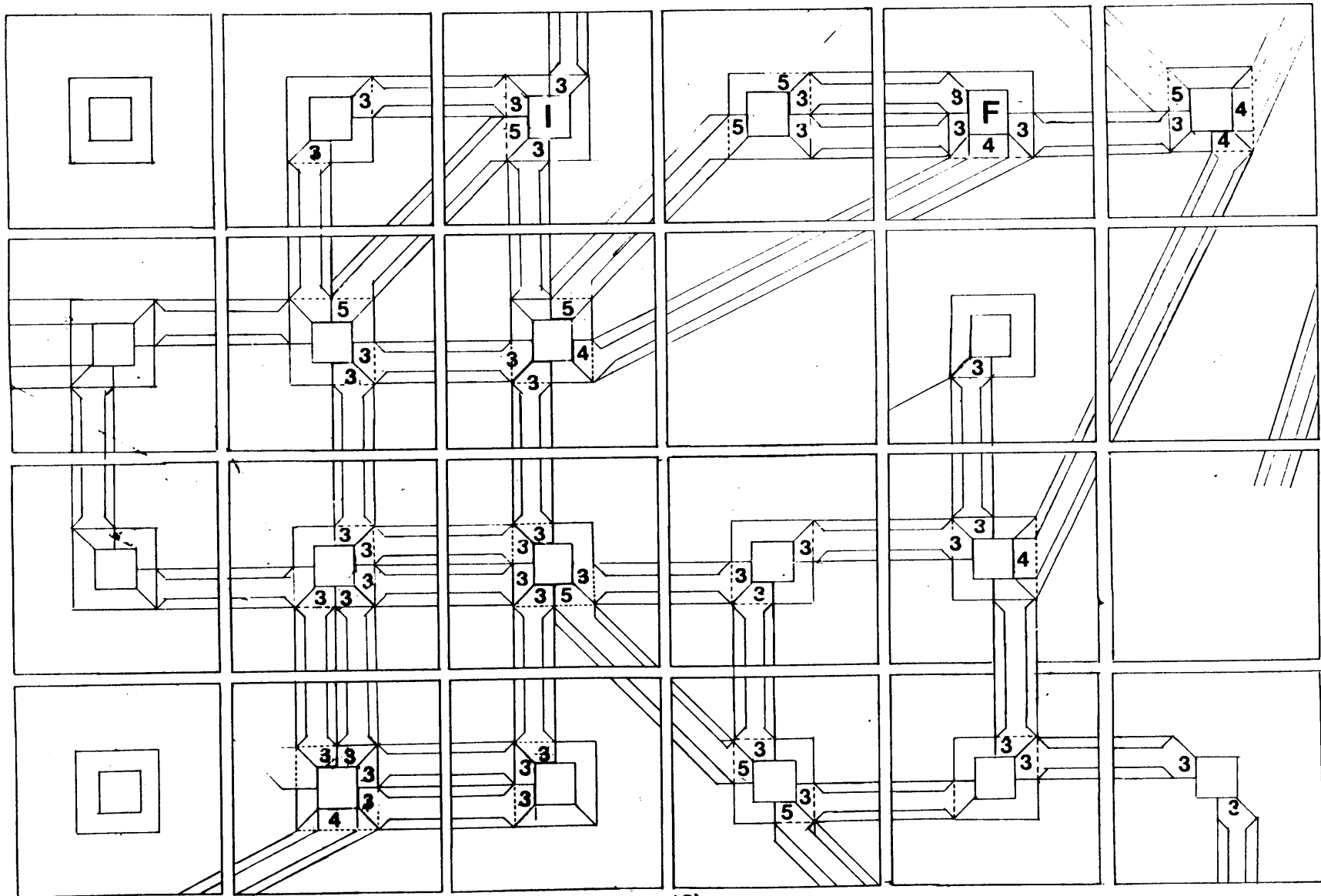

(f.4.19)

4.4 Columns

The arrangement of the columns constitutes a minimal ordering system which allows for great freedom when it comes to filling in different parts. While serving to unify the whole scheme, this column system is an inducement to the design of each space according to its specific requirements and locations.¹⁸

4.4.1 Primary Columns

The parking spaces beneath the building are to be executed within the module of the primary structural column and beam system.(f.4.20)

4.4.2 Secondary Columns

The secondary structural columns are round prefabricated elements with square fittings at both ends of the column.(f.4.20) Attached to these secondary columns are square hollow core capitals (f.4.21). The main function of these square capitals is to collect the connections with the various ceiling heights coming towards them from different directions.(f.4.22)

Furthermore, the secondary structural columns located in the office facilities should be profiled in such a way that they have maximum slotting capacity to accommodate primary and secondary partitions.

¹⁸ Herman Hertzberger, 'Lessons For Students in Architecture', Uitgeverij 010 Publishers, Rotterdam, p. 136.

In principle, these square column heads can accommodate beams from eight different directions.

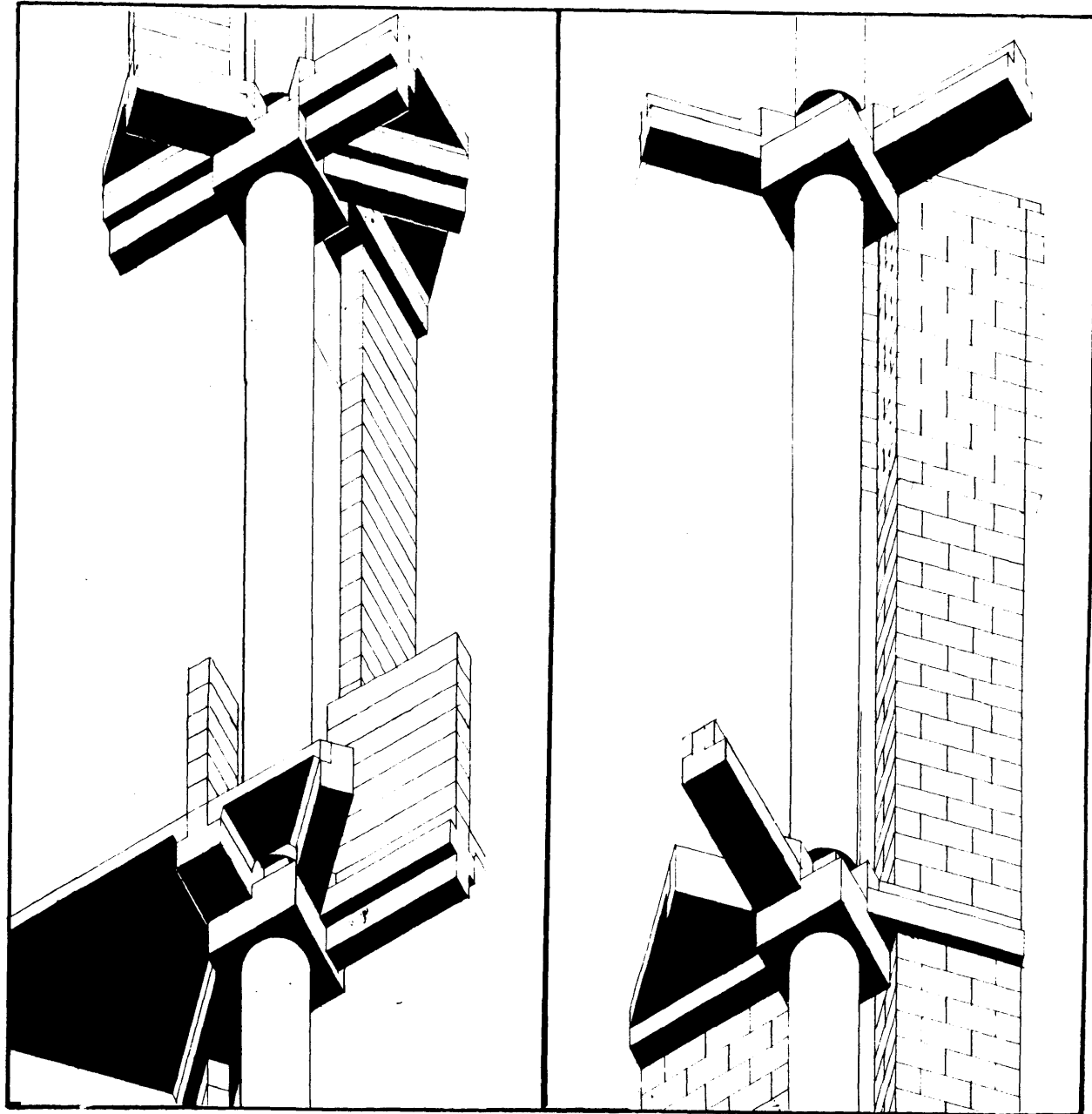

(f.4.22)

Primary and secondary structural columns.

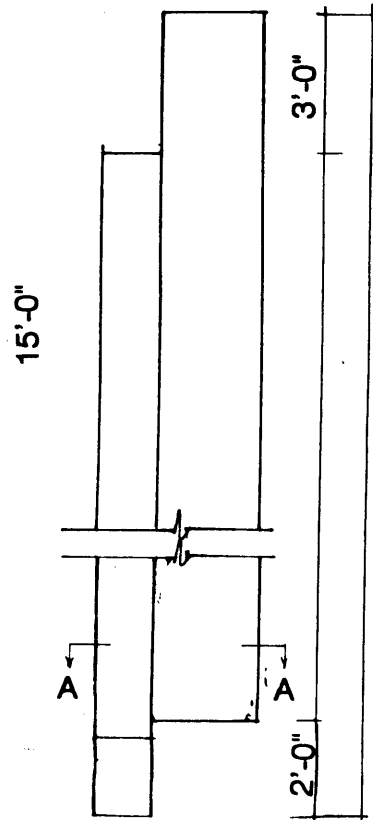

Elevation

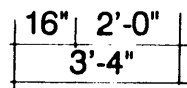

Section A-A

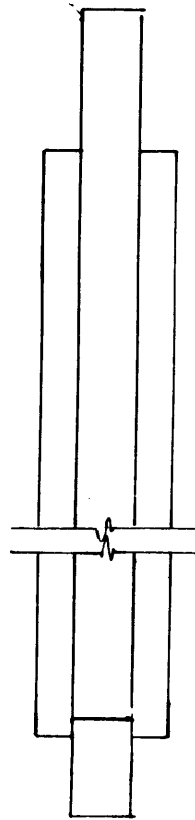

Elevation

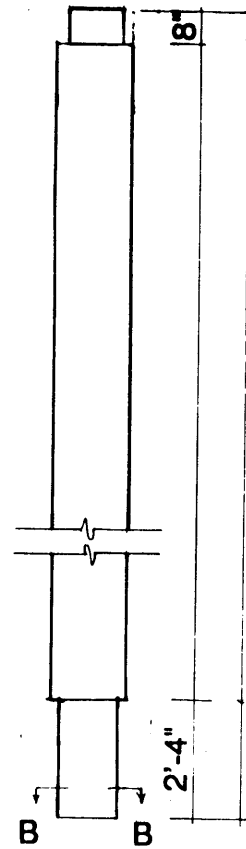

Elevation



Section B-B

(f.4.20)

67

A reinforced concrete hollow block, serving as the capital for the secondary structural columns.

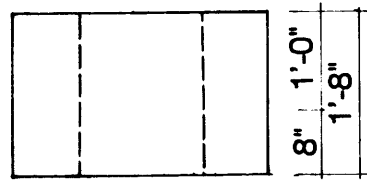

Elevation

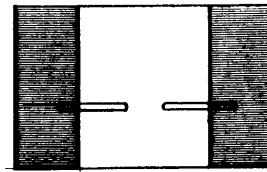

Section A-A

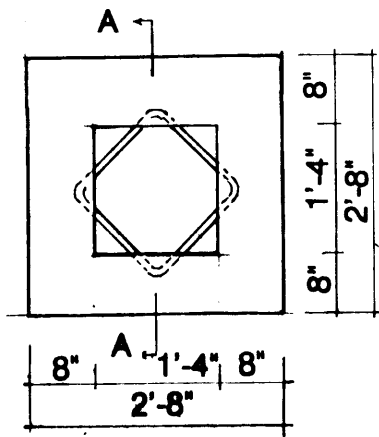

Plan

(f.4.21)

8

4.5 Partitions

*"The notion of the openness is just as fundamental as the separateness by partitions; indeed, the two are complementary so that enclosure and openness can exist only by the grace of the other; they relate to each other reciprocally."*¹⁹

The degree in which spaces are separate or open in relation to each other depends upon the location of partitions in habitable space. Regulating the personal contact in a particular situation ensures privacy when required. By introducing differences in floor levels, the scope of spatial possibilities is expanded; however, with different levels we must take into account those partitions which are higher up and look on the one which is placed below (f.4.21) The positions are therefore not equal, and we must see to it that the people in lower standing positions in sectional terms have the opportunity to avoid the gaze of the people at higher levels.

There should not be any space left over and unused between each of these partitions which in turn would become lost and worthless, thus serving no purpose. In other words, lost space becomes 'uninhabitable.' No space should be wasted by organizing each of these partitions in relation to each other. Space should be added not only in the most obvious places, but also in places that strike the eye as well as not attracting attention, i.e. between things.

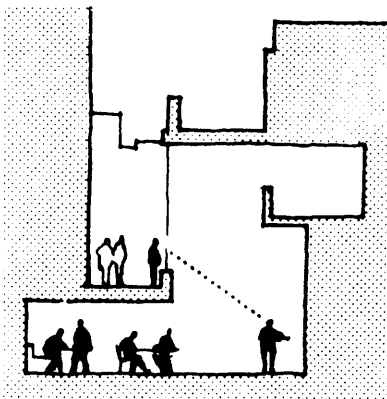

(f.4.23)

¹⁹ Herman Herzberger, 'Lessons For Student in Architecture', Uitgererij 010 Publishers, Rotterdam, p.202.

Performance Criteria

Both exterior and interior space dividing elements should provide similar conditions for combinatorial purposes. This means, conditions at joints should be standardized to allow for simple, but effective, jointing.

Profile of both interior and exterior space-dividing elements (i.e. especially at the edges) should be similar:

Provision for resistance to impact loads and wind loads should be expressed in performance terms

Basic framing and infill elements must be designed to allow for modular combinations of different heights and widths

The suspended ceiling should be determined by the rules of the band grid.

Connections between partitions and floor/ceiling should be standardized, and allowance must be made for deflection and assembly tolerances.

Installation should be possible without having to apply excessive force.

Specifications

Panel construction should have a class "A" flmae spread Rating in accordance with ASTM E84.

Finished panel shall be finished with reinforced vinyl woven backing weighing no less an 30 ounces per linear yard.

Acoustical, non-woven needle-punch carpet, with fused fibers to prevent unraveling or fray of material.

The wall panel construction shall be in accordance with ASTM E90-75 acoustical test procedure, specify rating 40.

Items such as unitized doors, clearstory windows, electrical service outlets, slotted trim of hang-on accessories, chalkboards, tackboards, and other items with high cost should be integral elements to the overall partition sub-system.

Connections must be strong enough to hold all elements firmly in place. this is accomplished by an internal spring-loaded top channel.)

This fastening device and connections should facilitate easy assembly/disassembly, and should not require the use of special tools (except where security calls tamper resistant connections.)

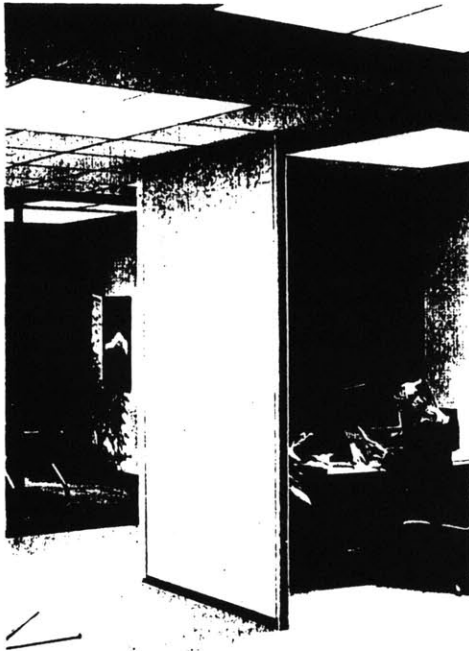

Portable panels are so versatile, applications are practically unlimited.

- Create a conference room or divide an existing room into temporary offices or meeting rooms.
- Close off a reception area for privacy and protection
- Make individual work stations without destroying the open look.
- Divide an Open-Plan classroom for needed individual activities.
- Make a closet or storage area.
- Provide attractive, tackable display areas.
- Create sight and sound barriers around audio/visual equipment, office machines or coffee area



Portable panels readily adapt to changing office patterns, yet no permanent attachment to floor, wall or ceilings are necessary.



Once panels are position the self-compensating, spring-loaded top seal is released by pulling a contained within the frame.



Spacesetter® panels are designed for precision alignment. Panels come together in a fine-line seam that presents a custom look.



Spacesetter® portable panels permit in-house relocation without interrupting usual

**SPACESETTER® PORTABLE PANEL
MODEL 204**

(f.4.24)

SCALE
 3" = 1'-0"
 (76) = (305)

EXPOSED T-BAR
 CEILING

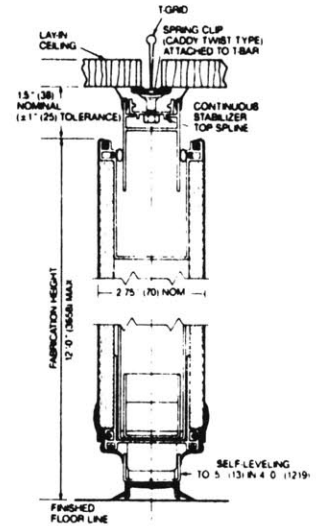

TYPICAL
 CROSS SECTION

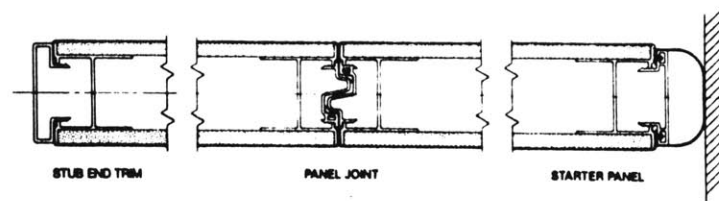

Spacesetter's® available options include electrical service outlets, unitized door and window panels, slotted trim for acceptance of hang-on accessories, chalkboards and tackboards, and custom finishes providing a totally flexible environment.

9

4.6 Cladding System

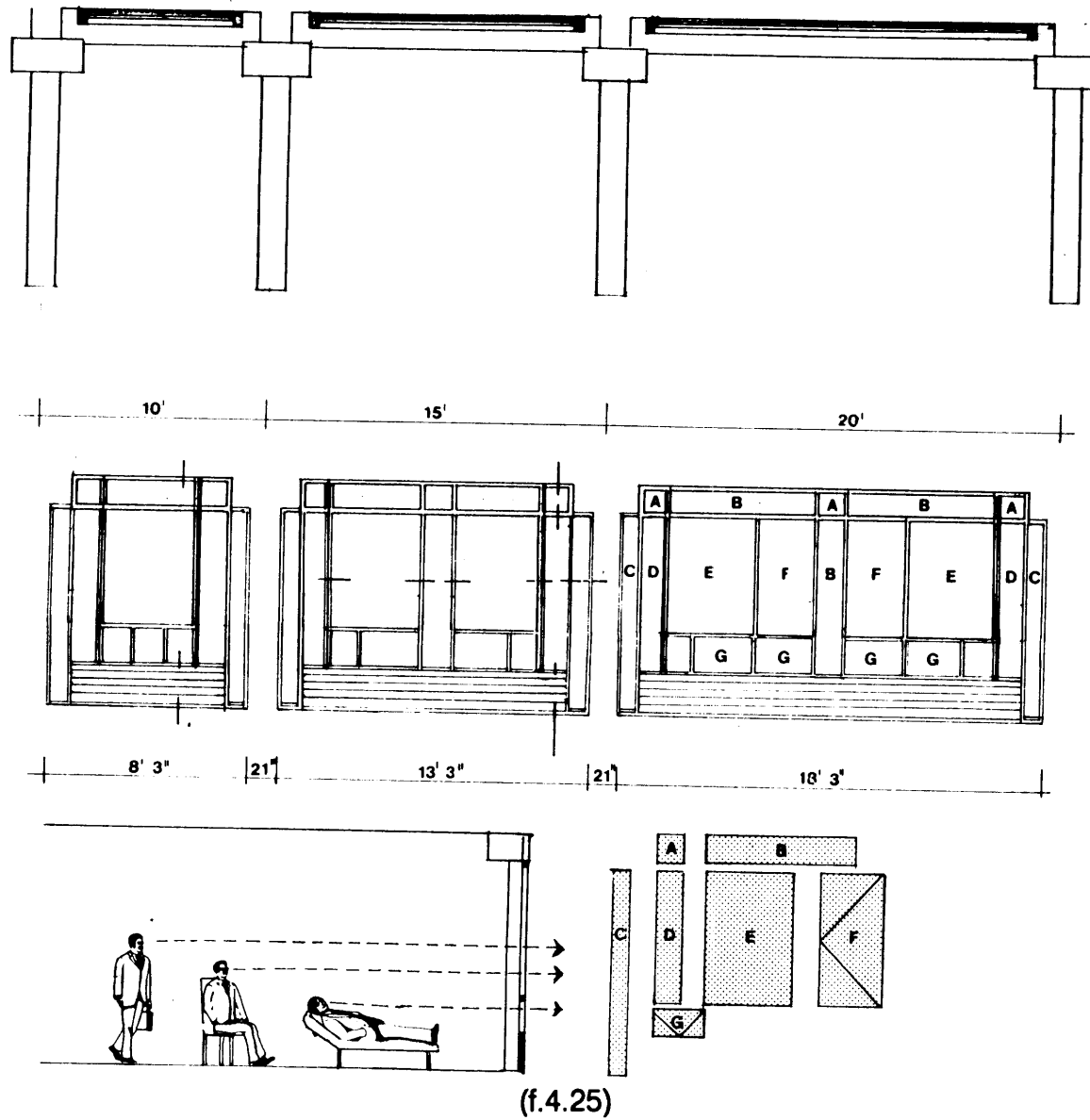

Performance Criteria	
1	Development of enclosure in to spacial zone
2	Cladding to be dimensional integrated with buildings major structural system
3	On site prefabrication to be kept to a minimum via panel prefabrication and preparation of cladding in shop
4	Dimensional accuracy of panels is critical
5	Increase square footage out from the building
6	Make use of zone of mullion for uses: Large window cill Exterior ventilation box for individual control of air circulation and light. Attachment of sunscreen on east, south, and west sides of building.
7	Individual Control of Light and Ventilation
8	Variety and adaptibility of Elements so that Functions can change and the facade can respond.
9	Increase Square footage out from the Building.
Specifications.	
1	Finish to be two coats flucropolymer coating applied electrostacally.
2	Joints between panels consists of silicone sealant with backer road.
3	Panel to be composite of two aluminun pans adhered under heat and pressure using epoxy reinforced with lightweight aluminun channels 4" thick.
4	Core is filled with 2 1/2 CF of Polyurethane insulation
5	Thermal break at panel connection thru use of cont.preferred gasket set in slots.
3	Glazing to be low-emissivity to control solar, set in extruded thermo break aluminun frame

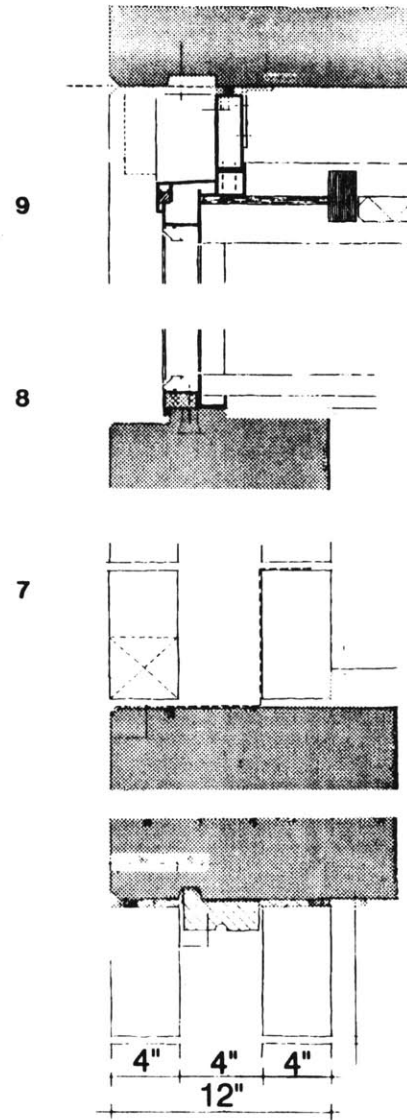
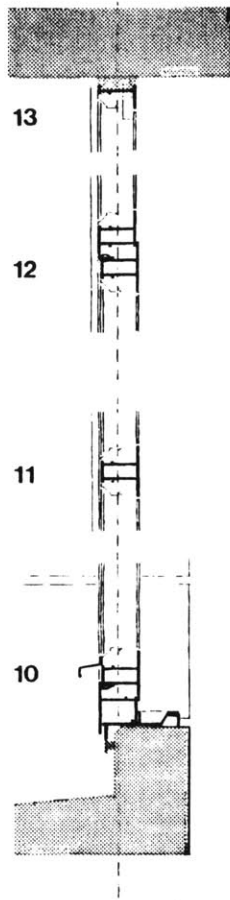
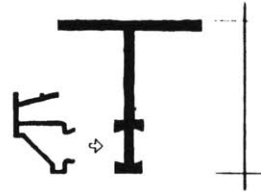
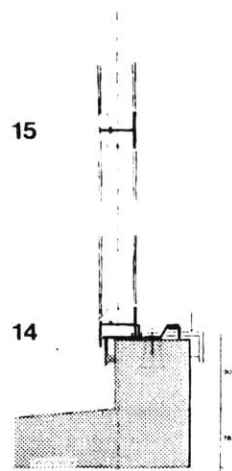
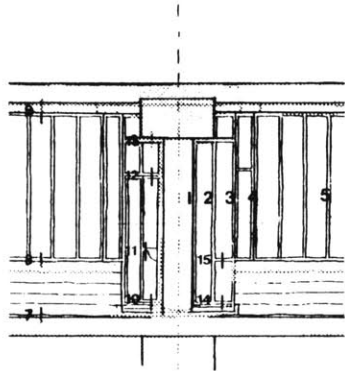

(f.4.26)

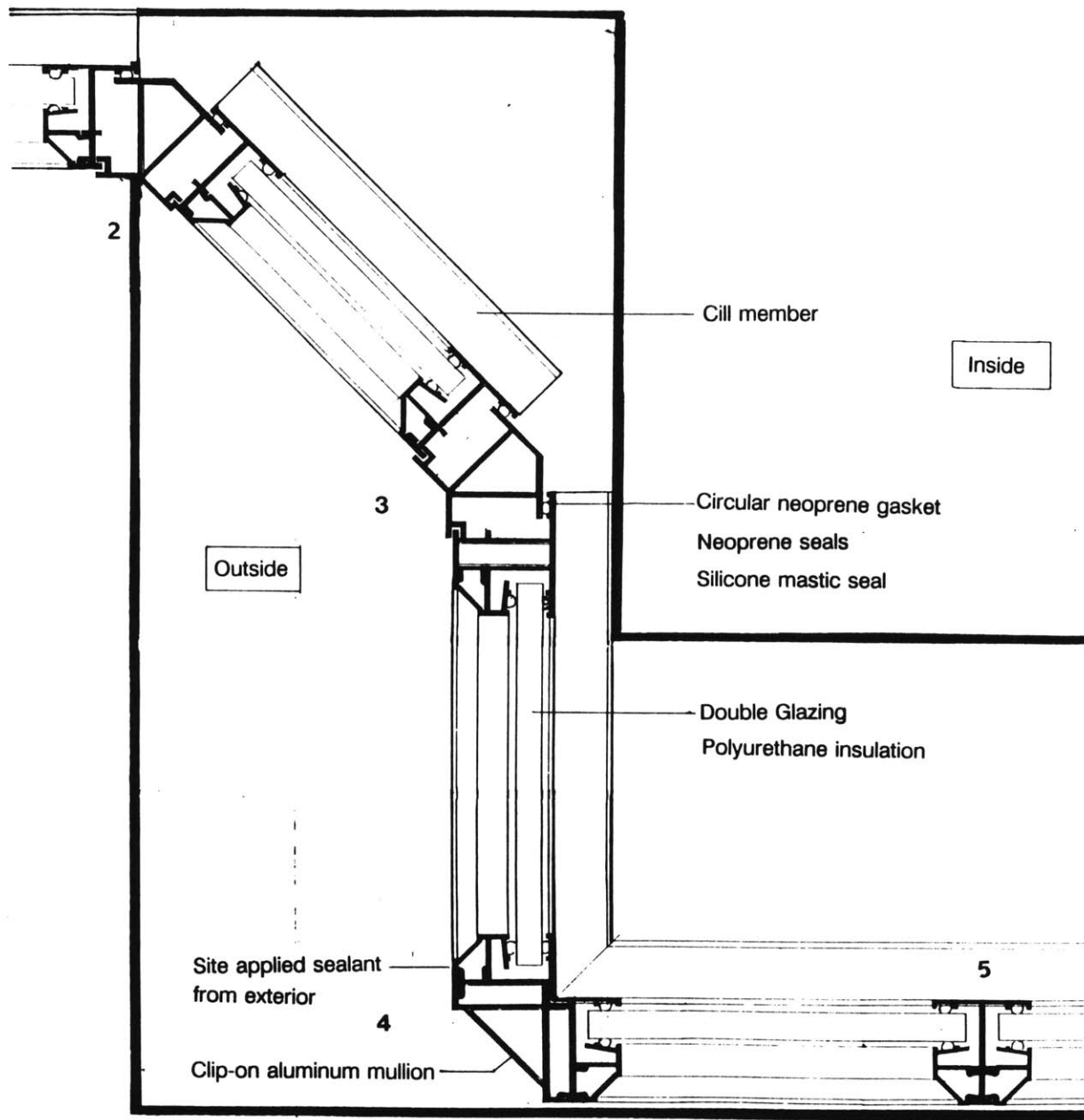

10

4.7 Floor Elements

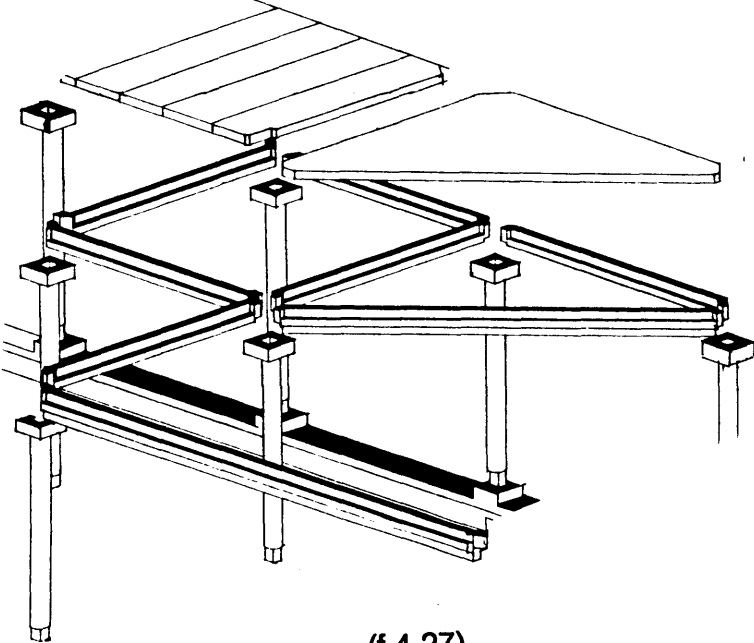

(f.4.27)

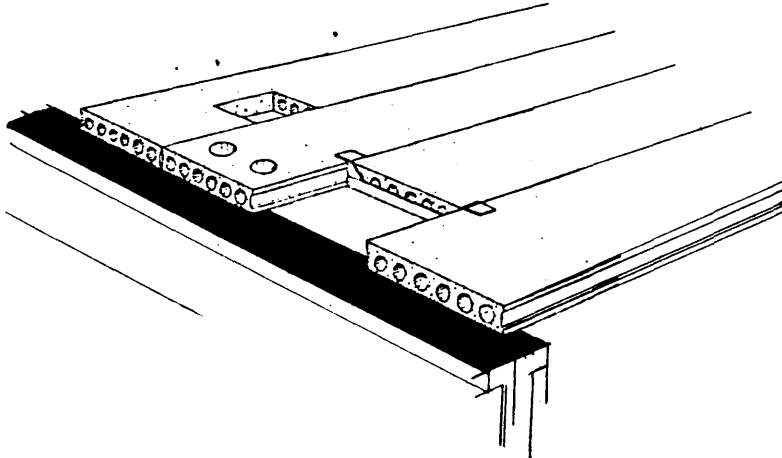

(f.4.28)

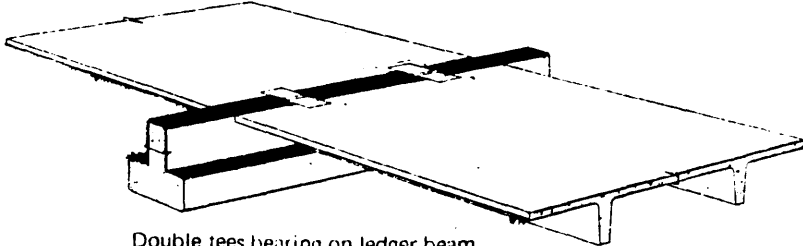

Double tees bearing on ledger beam.

(f.4.29)

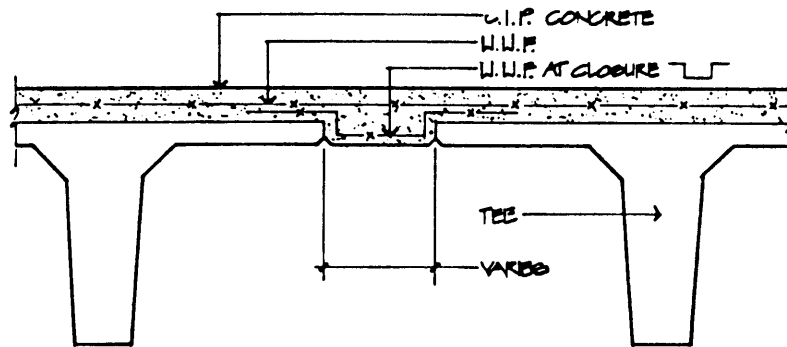

TEE PLANGE CONNECTION
CLOSURE FOUR
SPREAD DOUBLE TEE SYSTEM

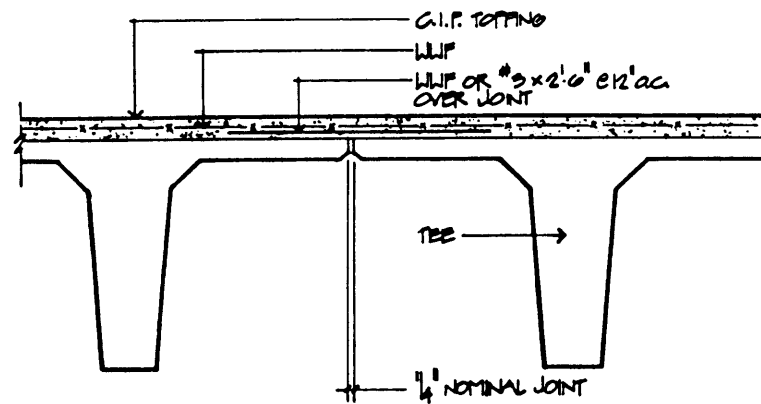

TYPICAL TEE PLANGE CONNECTION

(f.4.30)

PARTITION ATTACHMENT DETAILS

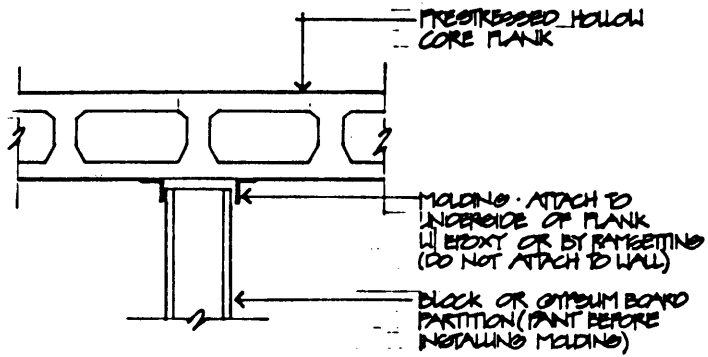

OPTION 1

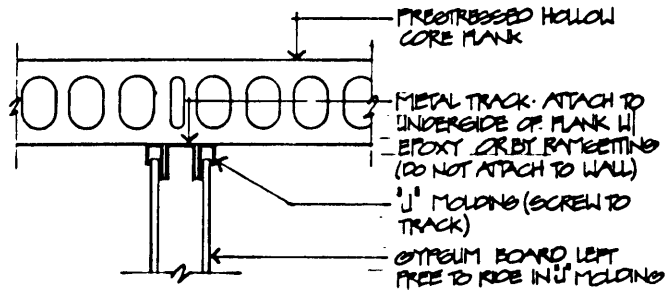

OPTION 2

(f.4.31)

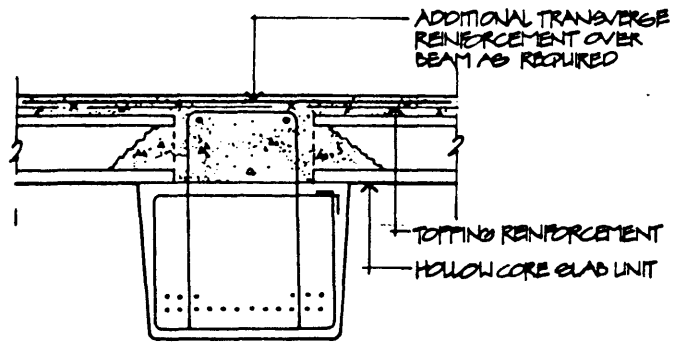

PRESTRESSED CONCRETE GIRDER

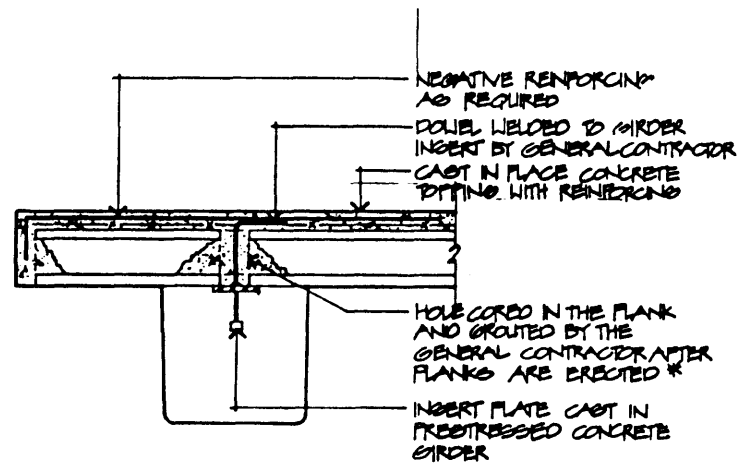

TYPICAL HOLLOW CORE PLANK CANTILEVER DETAIL

*NOTE THAT FOR SPAN-DECK PROCESS OPENINGS MAY BE PREFORMED IN THE PLANT

(f.4.32)

4.8 Assembly Sequence

Through the use of prefabricated pieces and the design of a structural system incorporating the process of assembly, the structure not only provides for spatial flexibility, but also construction flexibility and ease. (f.4.30)

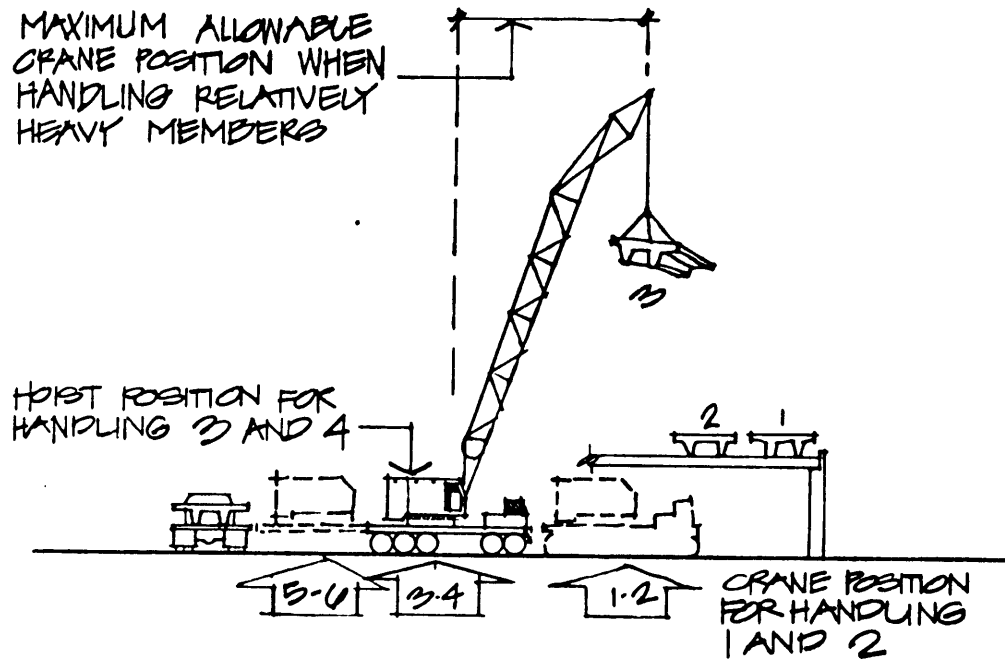

d) HEAVY LOADS (f.4.33)

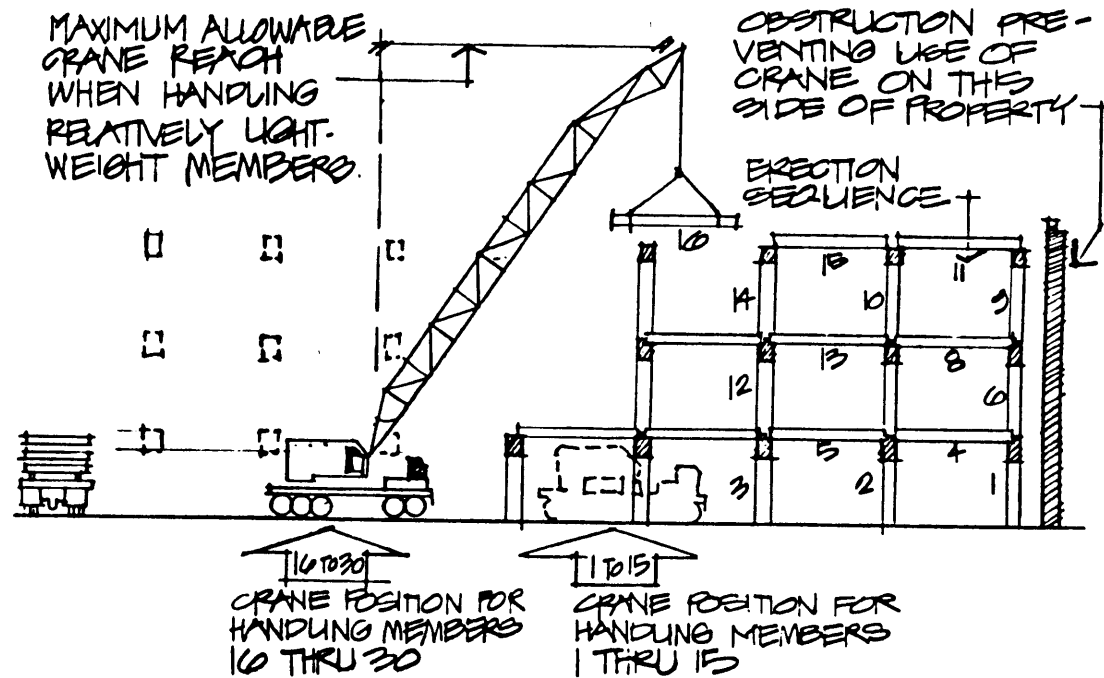

b). LIGHT LOADS

(f.4.34)

Section 5: Positional Coordination

*'Based on the modular band grid, positional and dimensional coordination permits the standization of structural elements, without giving up flexibility and variability. But also positional coordination allows the integration of standard non-structural elements with a minimum of waste, due to unnecessary cutting, fitting, bending, at joints.'*²⁰

5.1 The Tartan Band Grid as a Positional Coordination System.

The modular tartan band grid is used as an abstract spatial reference guide on the positioning and dimensioning of structural elements within space. In other words, the modular order of the tartan band grid merely acts as a convenient tool for fixing the position of structural and non-structural elements within a logically consistent set of geometrical relations. In addition, the modular grids allow the positioning of any given element or space in both its horizontal and vertical aspects and thus clarify their relationship with other elements throughout the system.

²⁰ Eric Dluhosh, PH.D. Notes in Building Systems II, Course 4.52, MIT. 1989

5.2 Location of Components within Tartan Band Grid

5.2.1 Location of Secondary Partitions and Enclosure

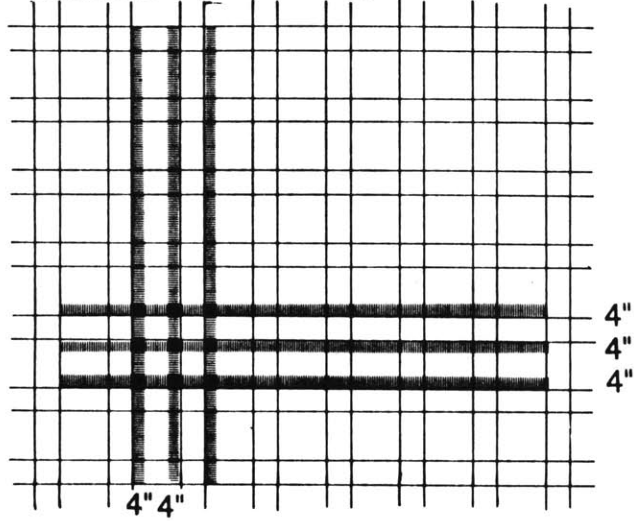

5.2.3 Location of Primary Structure

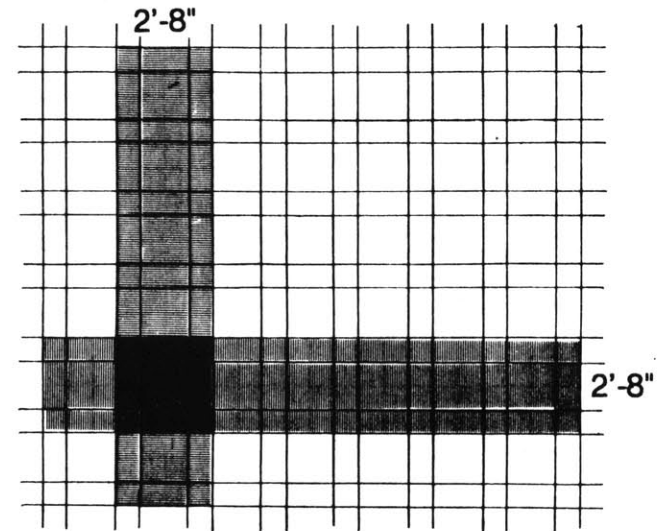

5.2.2 Location of Primary Structural Partitions

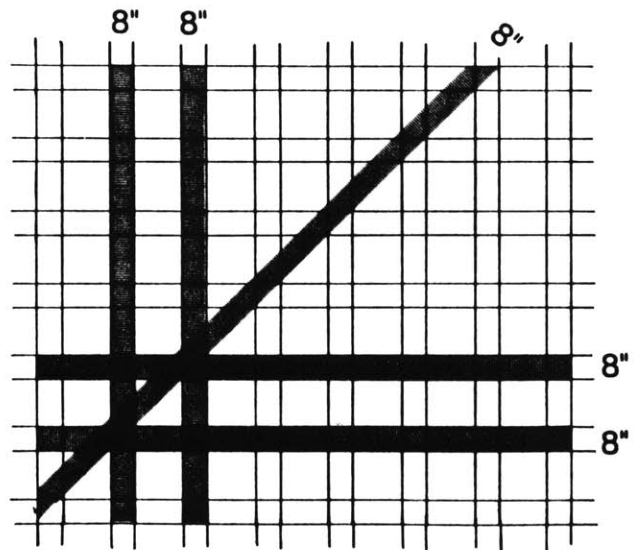

5.2.4 Location of Secondary Structure

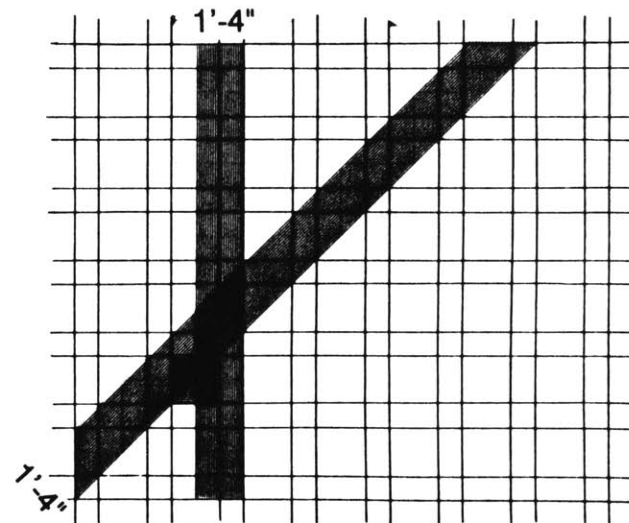

5.3 Dimensions of Structural Components

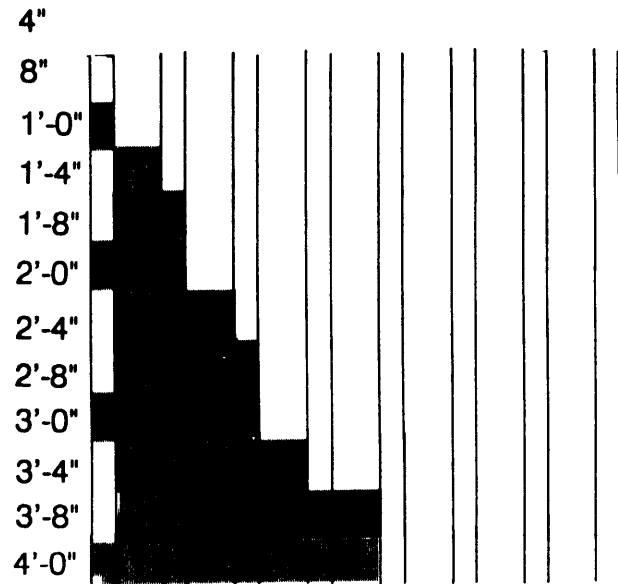

5.4 Components located within Bands

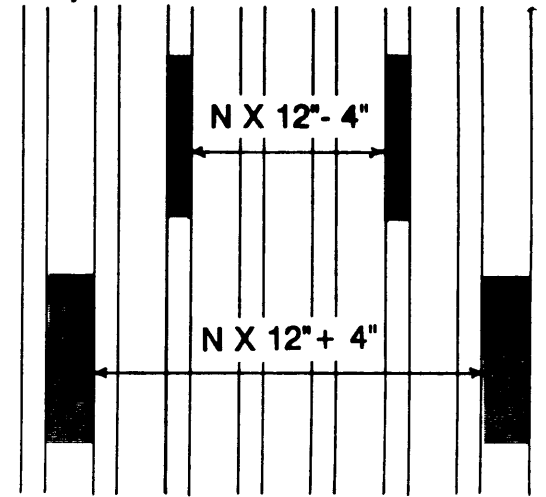

Edges of the Components

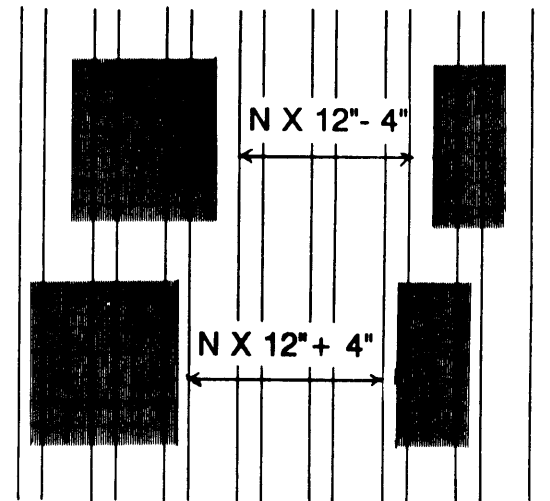

5.5 Nominal Dimensions

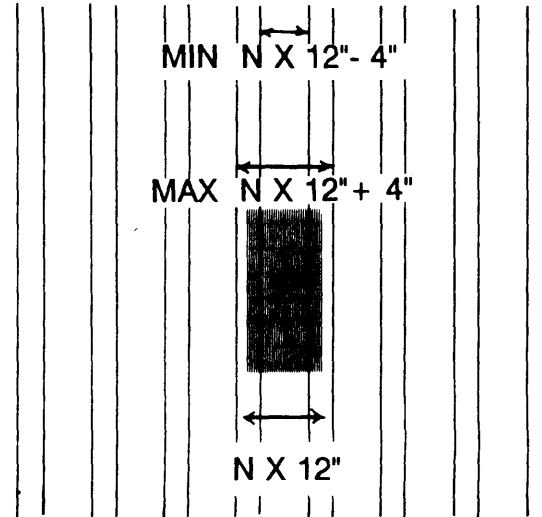

N = A multiple of the module of the grid that is used.

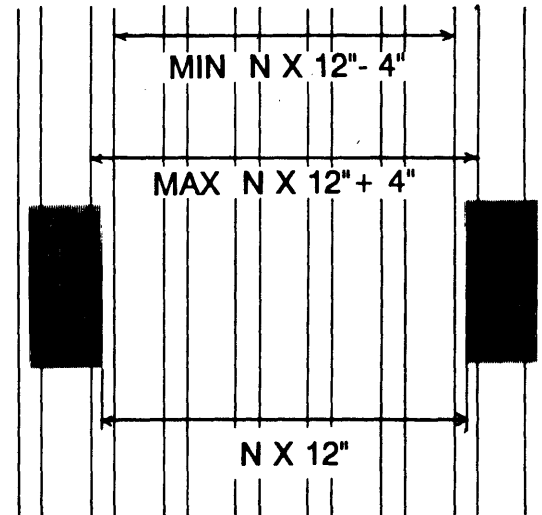

5.6 The Vertical Plane

- a. Both the Primary and Secondary structural columns will be placed in the 16 inch bands, or their intersection.
- b. All partitions and/or infill elements within the primary structural system will be placed in the 8 inch bands.
- c. All partitions and/or infill elements within the secondary structural system will be placed in the 4 inch bands.

5.6.1 Positioning of Columns

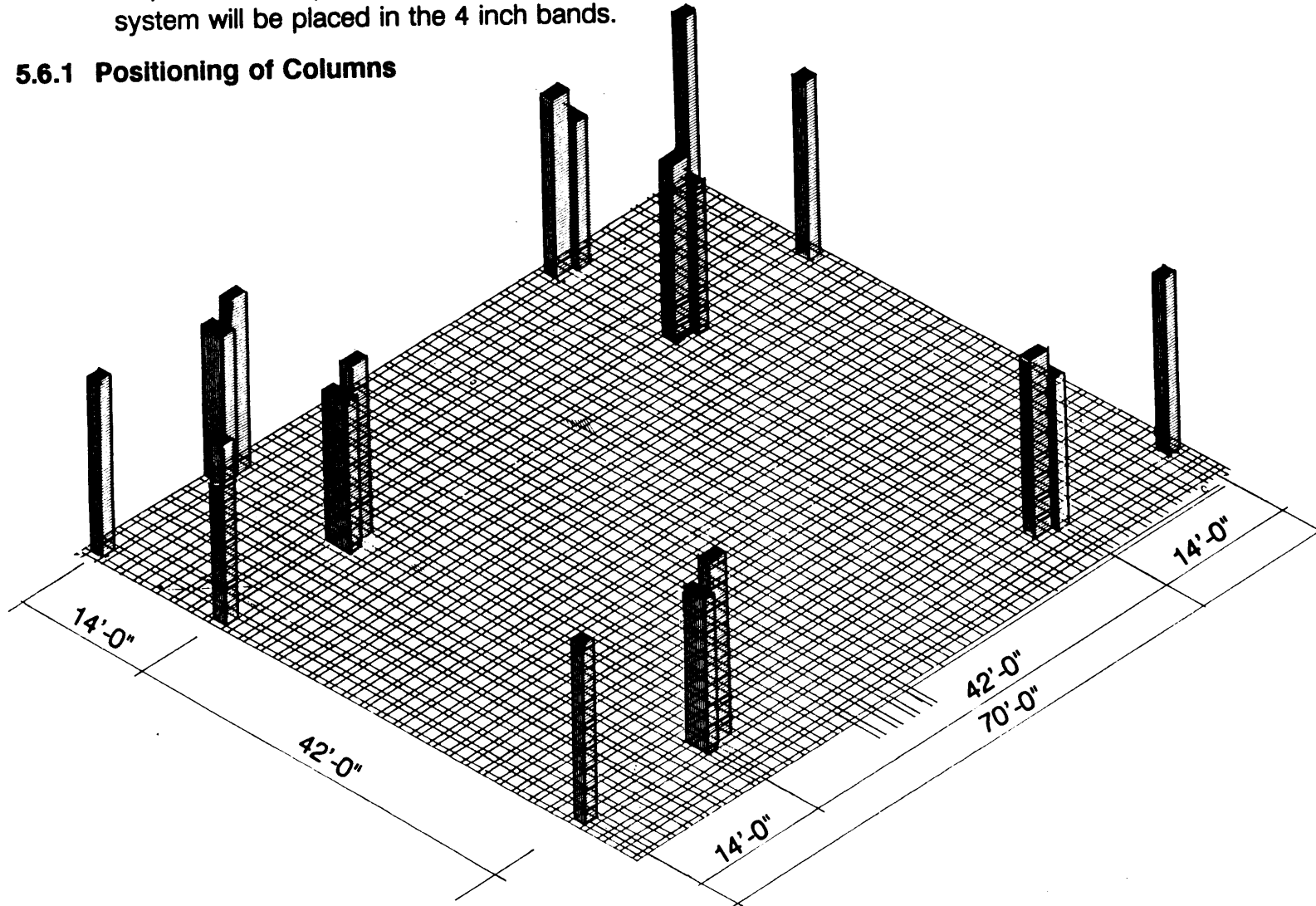

5.6.2 Positioning of Partitions

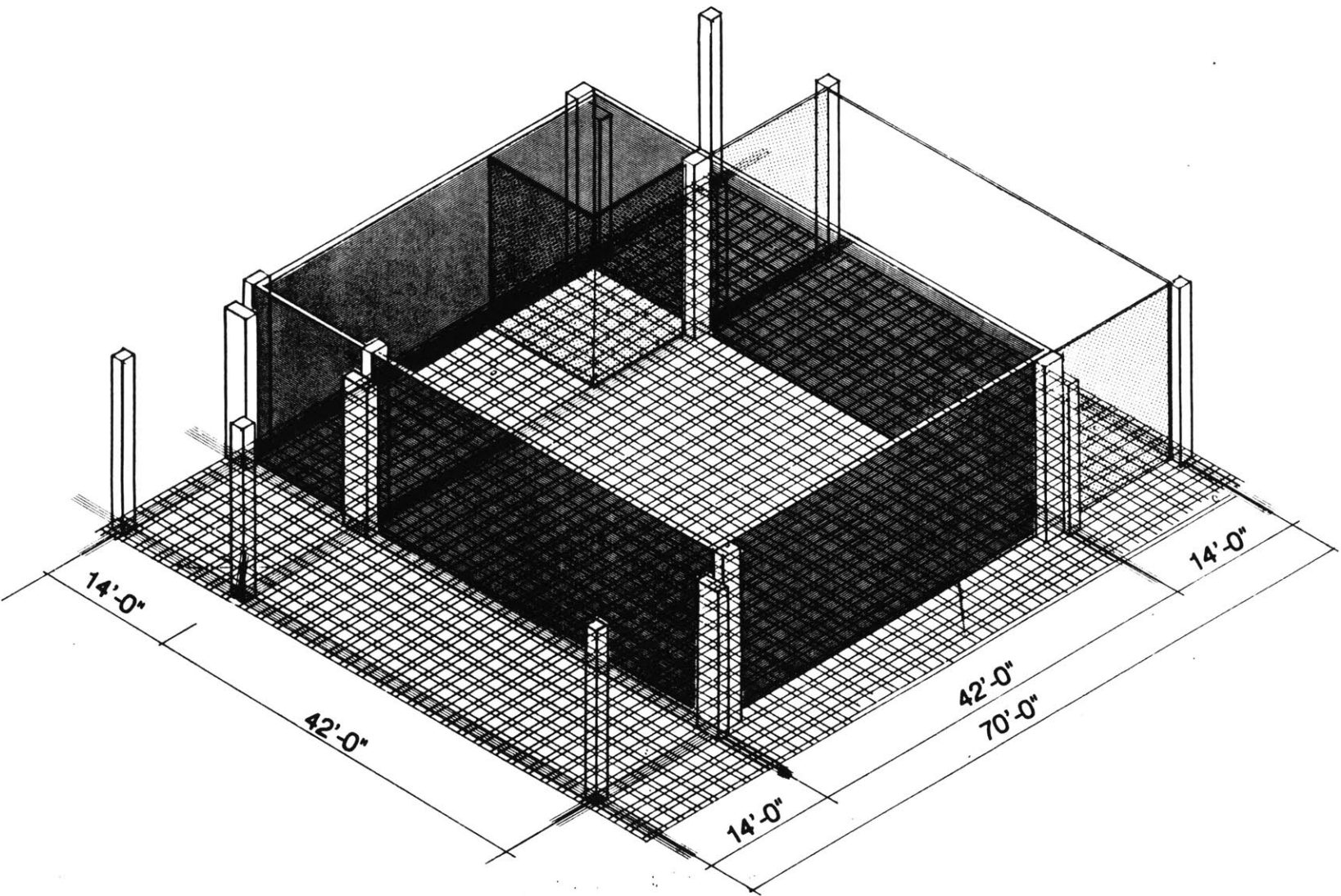

5.7 Basic Courtroom Plan Determinants

5.7.1 Structural

The basic structural bay dimensions are 42'-0" x 28'-0" is based on the weight to span ratio, which, in turn, is the result of portability of large structural elements.

5.7.2 Dimensional

The nationally accepted 4" planing module has been used throughout the study as the basic increment for room size.

5.8 Relationship of Structural Elements to Basic Courtroom Plan

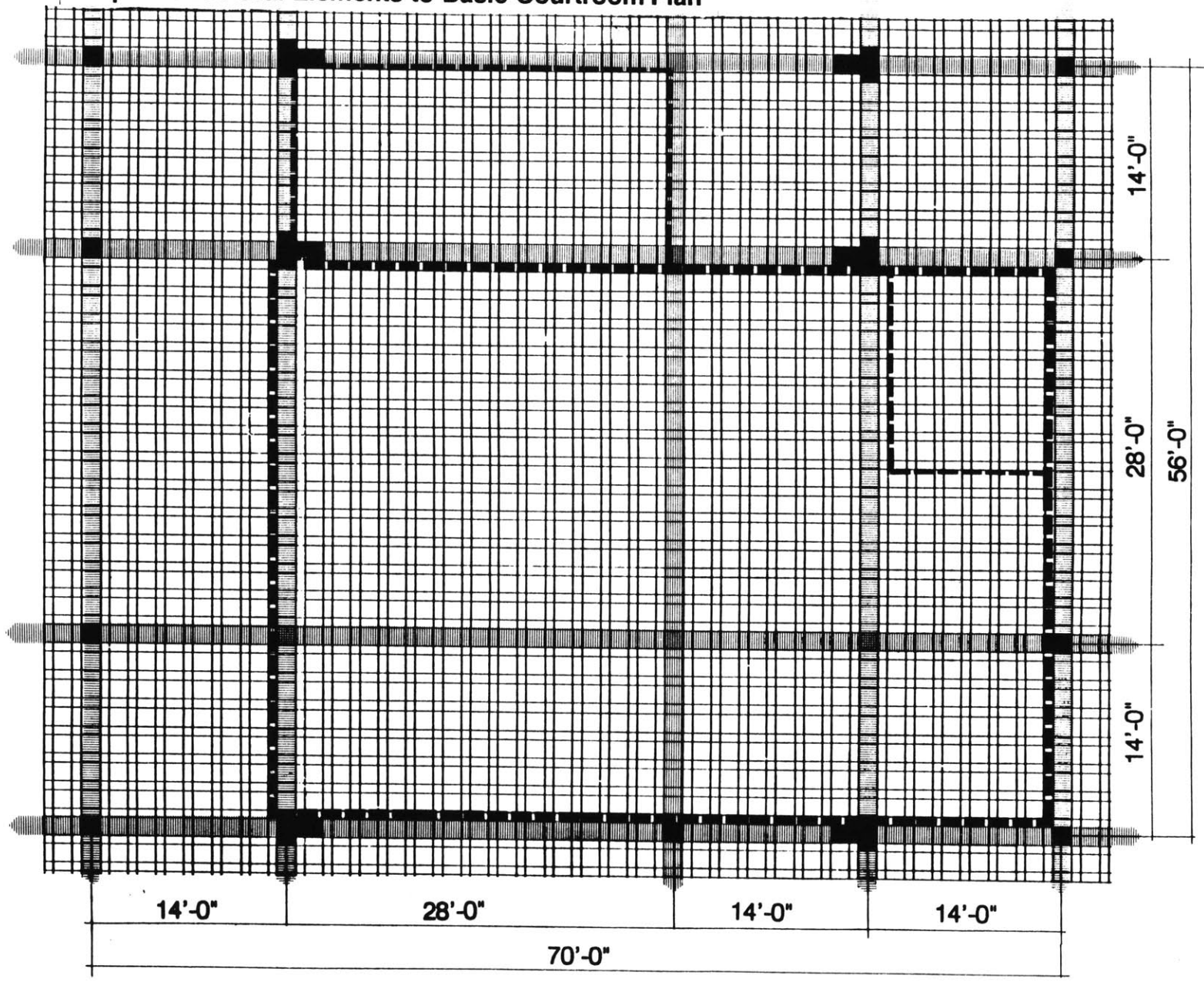

5.9 Flexibility and Variability of Courtroom Within Modular Grid

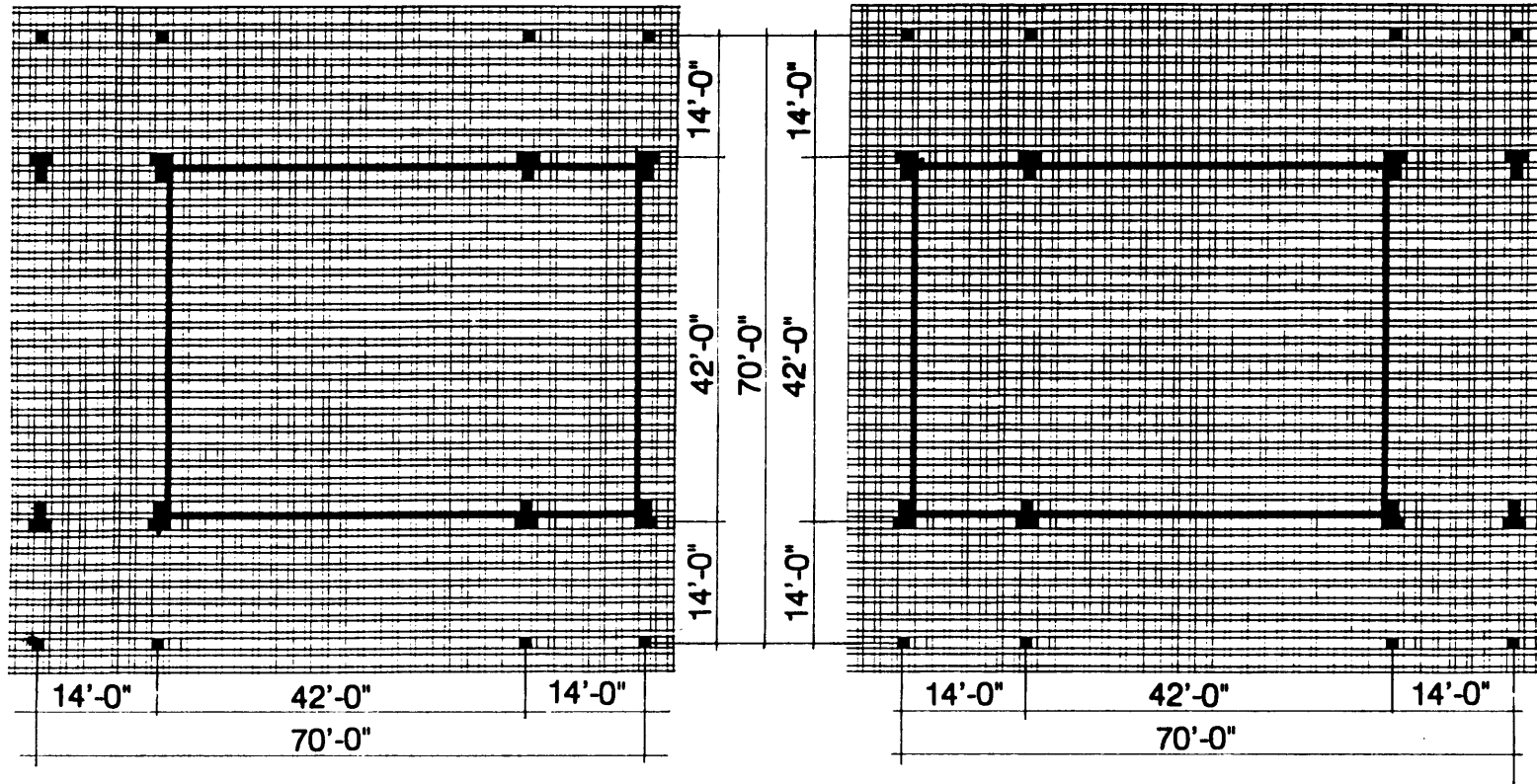

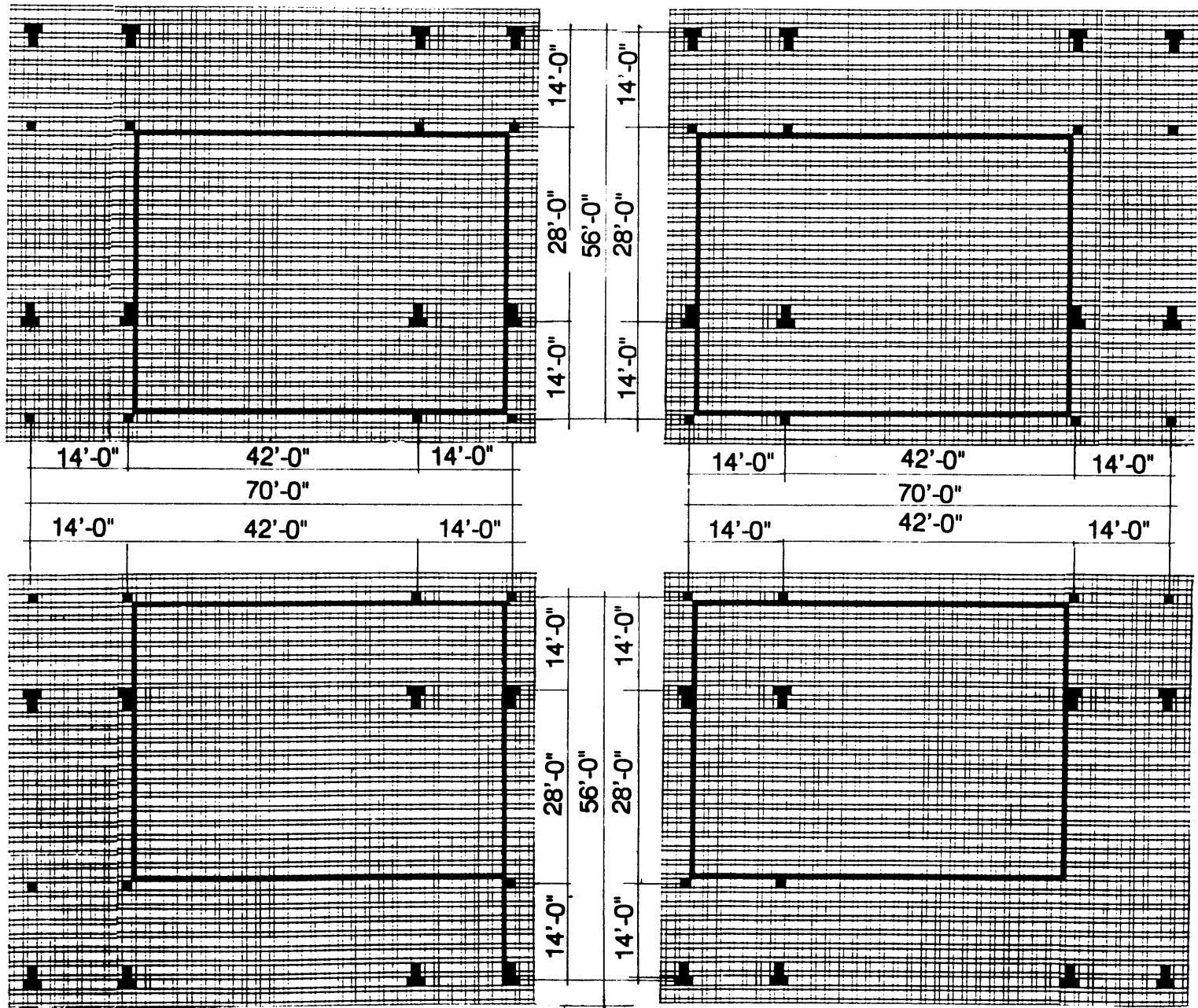

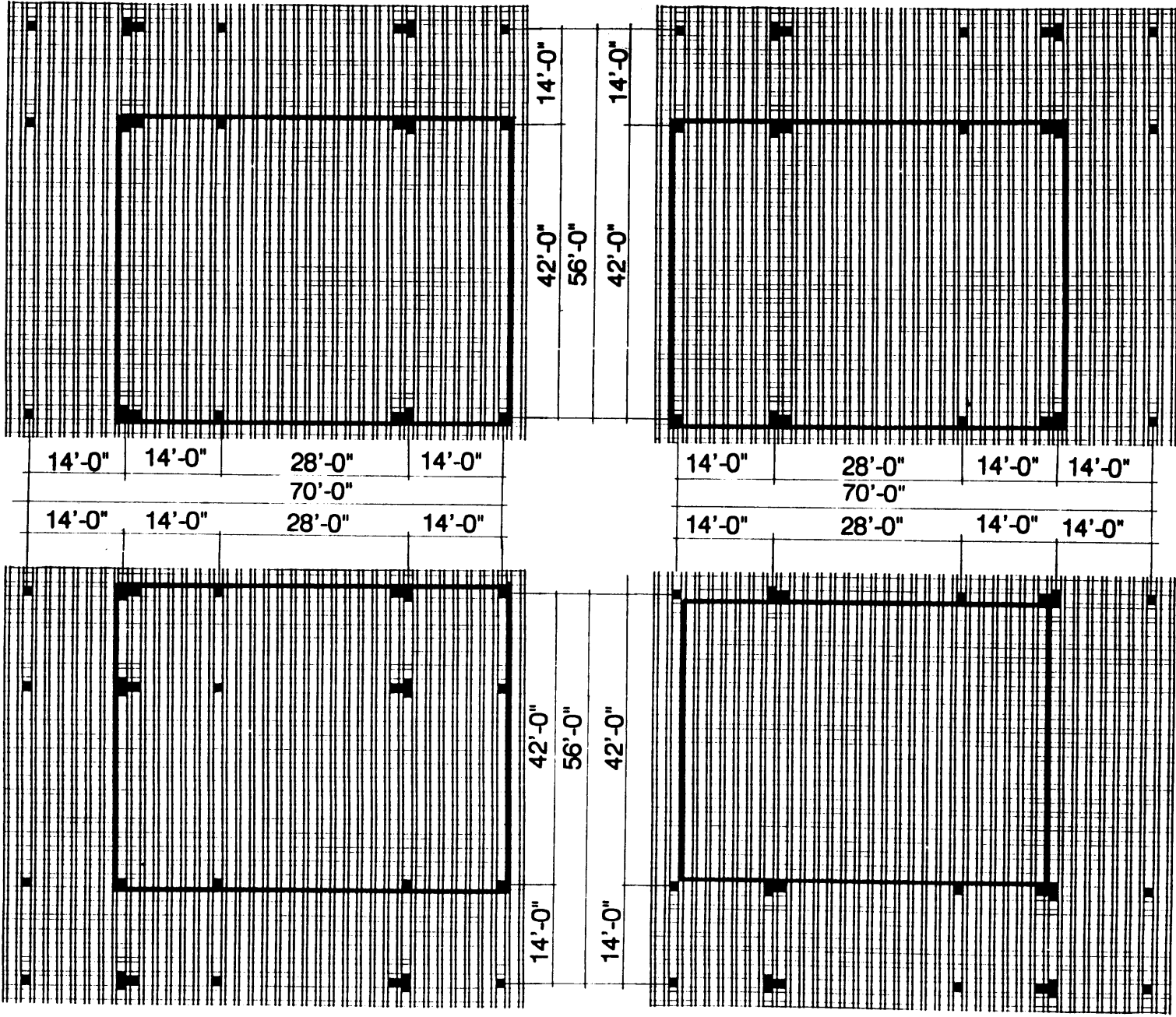

Section 6: Conclusions

Design methodology is a systematic strategy in design. It is a strategy in which an open attitude towards examining all feasible options for subsequent evaluation must be maintained as long as possible by the designer. This approach coupled with the designer's ability to visualize user needs is the formula to achieving a successful design.

The objectives of the thesis were to use a systematic approach to design a public building located in the Government Center, Boston. I attempted to tie into this design process a more user friendly approach.

Since this thesis is a study and not an actual building, it has problems and limitations. One of the limitations is the inability to gather actual user requirements and needs. The use of Herman Hertzberger's principles in the design process gave me the opportunity to apply his observations to the elements of my design.

In the design process of this courthouse, I accomplished the following:

- After site analysis rules were established in order to design the courthouse to conform with its surrounding site. The final building design does work in conjunction with some of these rules established through site analysis.
- The final building design defines different spatial zones throughout the building and arrives at an effective solution between private and public use zones.
- A preliminary prefabricated building system is utilized effectively for the programmatic sizes of the courtrooms and other use spaces.
- A thorough exploration of the position coordination of building elements in relation to a modular band grid, ultimately resulted with a redefinition of the sizing and location of elements within the structural building system.

Program

COURTHOUSE USES	QUANTITY	SQUARE FOOTAGE	SUB-TOTAL FOOTAGE	TOTAL FOOTAGE	ROOM DIMENSIONS
I. District Court					
District Courtrooms Large	4	3,500	14,000		70x70
Courtroom Support	4	2,000	8,000		50x40
District Courtrooms Standard	16	3,000	48,000		60x50
Courtroom Support	16	1,000	16,000		25x40
			86,000		
Resident Judge's Suite	20	2,000	40,000		50x40
Visiting Judge's Suite	2	1,000	2,000		25x40
			42,000	128,000	
District Court Magistrate					
Magistrate-Judge Courtrooms	6	1,500	9,000		50x30
Courtroom Support	6	1,500	9,000		50x30
			18,000		
Magistrate-Judge Chambers	6	1,500	9,000		50x30
Shared Meeting Area	1	400	400		20x20
Shared Library	1	800	800		40x20
			10,200	28,200	
District Court Clerk					

COURTHOUSE USES	QUANTITY	SQUARE FOOTAGE	SUB-TOTAL FOOTAGE	TOTAL FOOTAGE	ROOM DIMENSIONS
Clerk	1	300	300		20x15
Clerk Deputy	1	250	250		15x17
Secretaries to Clerk & Deputy	2	200	400		15x13
Computer Area	1	1,000	1,000		25x40
Evidence Area	1	500	500		25x20
Storage Area	1	800	800		40x20
Mail Room	1	500	500		25x20
Meeting Area	1	600	600		30x20
			4,350		
Jury Waiting Area	1	2,500	2,500		50x50
Jury Relaxing Area	1	1,500	1,500		50x30
Closet & Kitchen	1	1,000	1,000		25x40
Toilet	2	600	1,200		30x20
			6,200	10,550	
Pretrial Services					
Pretrial Services Officers	10	250	2,500		17x15
Clerk Open Office Space	1	1,000	1,000		25x40
Reception Area	1	400	400		20x20
			3,900	3,900	

COURTHOUSE USES	QUANTITY	SQUARE FOOTAGE	SUB-TOTAL FOOTAGE	TOTAL FOOTAGE	ROOM DIMENSIONS
Probation					
Probation Officers	25	300	7,500		20x15
Open Secretarial Area	1	3,000	3,000		60x50
			10,500	181,150	
II. Court of Appeals					
Appeal Courtroom Large	1	3,000	3,000		60x50
Courtroom Support	1	2,000	2,000		60x40
Appeal Courtroom Small	1	2,000	2,000		60x40
Courtroom Support	1	1,000	1,000		25x40
Judge's Suites	9	2,500	22,500		50x50
			30,500	30,500	
Appeals Clerk					
Appeals Clerk	1	300	300		20x15
Secretary	2	200	400		15x13
Administrative Manager	1	400	400		20x20
Clerical Stations	1	2,000	2,000		50x40
Records	1	4,000	4,000		50x80
Computer Area	1	1,000	1,000		25x40
Toilet	1	600	600		30x20

COURTHOUSE USES	QUANTITY	SQUARE FOOTAGE	SUB-TOTAL FOOTAGE	TOTAL FOOTAGE	ROOM DIMENSIONS
			8,700	8,700	
Court Library					
Stacks	1	10,000	10,000		250x40
Reading Area	1	5,000	5,000		125x40
Exhibit Area	1	800	800		40x20
Librarians & Assistants	1	1,500	1,500		50x30
Computer Area	1	200	200		15x13
Staff Lounge	1	500	500		25x20
			18,000	18,000	
Staff Attorney					
Attorneys	10	300	3,000		20x15
Secretaries	8	300	2,400		20x15
Computer, Facsimile, Copy, Etc.	1	400	400		20x20
Relaxing Area	1	300	300		20x15
Meeting Area	1	800	800		40x20
			6,900	64,100	
IV. Prisons & US Marshall					
Cells	10	150	1,500		15x10

COURTHOUSE USES	QUANTITY	SQUARE FOOTAGE	SUB-TOTAL FOOTAGE	TOTAL FOOTAGE	ROOM DIMENSIONS
Courtroom Holding Cell	30	150	4,500		15x10
Prisoner/Attorney interview	5	100	500		10x10
Processing Area	1	250	250		15x17
Secured Sallyport	1	1,000	1,000		25x40
			7,750		
Open Squad Area	1	3,500	3,500		70x70
Deputy Marshals	5	200	1,000		20x10
Secretary	1	150	150		15x10
Court Security Officers	1	2,000	2,000		50x40
			6,650	14,400	
v. US Attorney					
Chief US Attorney	1	300	300		20x15
Meeting Area	1	300	300		20x15
Secretary	1	300	300		20x15
Open Office	1	800	800		40x20
Toilet	1	60	60		10x6
Assistant US Attorney	1	240	240		20x12
			2,000	2,000	
US Attorney Area	80	200	16,000		20x10

COURTHOUSE USES	QUANTITY	SQUARE FOOTAGE	SUB-TOTAL FOOTAGE	TOTAL FOOTAGE	ROOM DIMENSIONS
Paralegal Area	4	300	1,200		20x15
Secretaries Area	1	3,000	3,000		60x50
Visitor's Area	1	200	200		15x13
Conference Area	1	300	300		20x15
Witness Area	1	1,000	1,000		25x40
Xerox's, Supply, File	1	750	750		35x20
			22450	23.250	
VI.General Services Administration					
Workstation Open Space	1	3,000	3,000		50x40
Storage Room	1	200	200		15x13
Conference Room	1	300	300		20x15
				3,500	
VII.Shared Space					
Day Care Center	1	3,500	3,500		70x70
Restaurant	1	6,000	6,000		100x60
Fitness Center	1	2,000	2,000		50x40
				11,500	
IX.Building Support					
Loading Docks	6	300	1,800		20x15

COURTHOUSE USES	QUANTITY	SQUARE FOOTAGE	SUB-TOTAL FOOTAGE	TOTAL FOOTAGE	ROOM DIMENSIONS
Temporary Storage	4	300	1,200		20x15
Bulk Storage	1	1,000	1,000		25x40
Maintenance Office	1	800	800		40x20
				4,800	
X. Parking					
Parking Facilities			80,000	80,000	1000x80
TOTAL				383,9000	

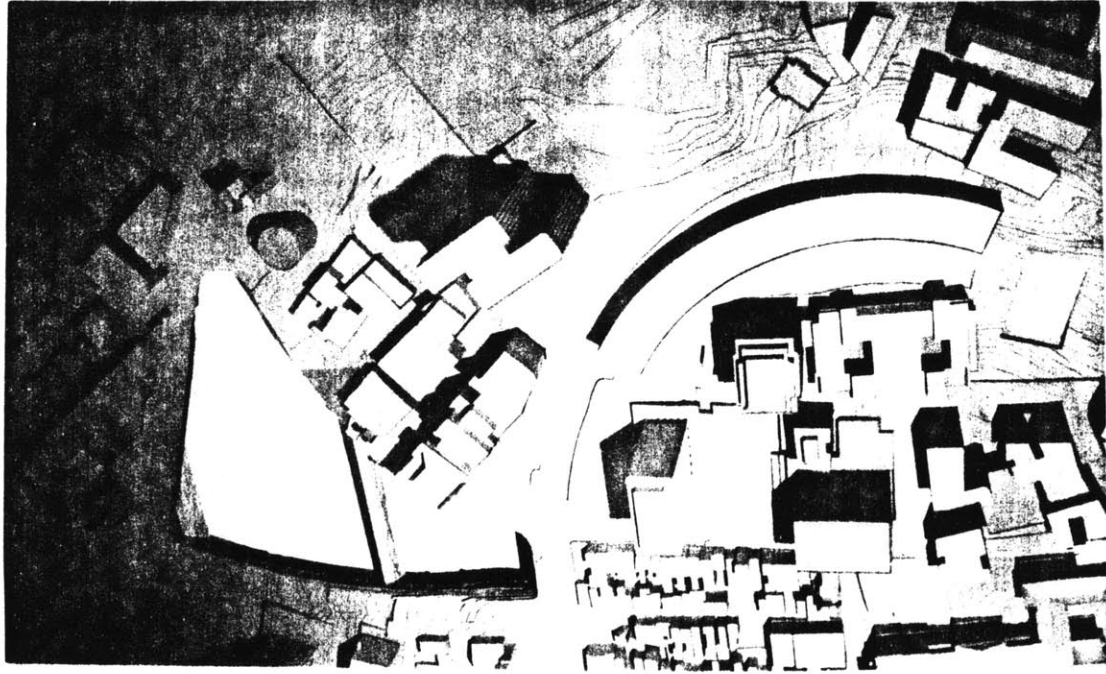

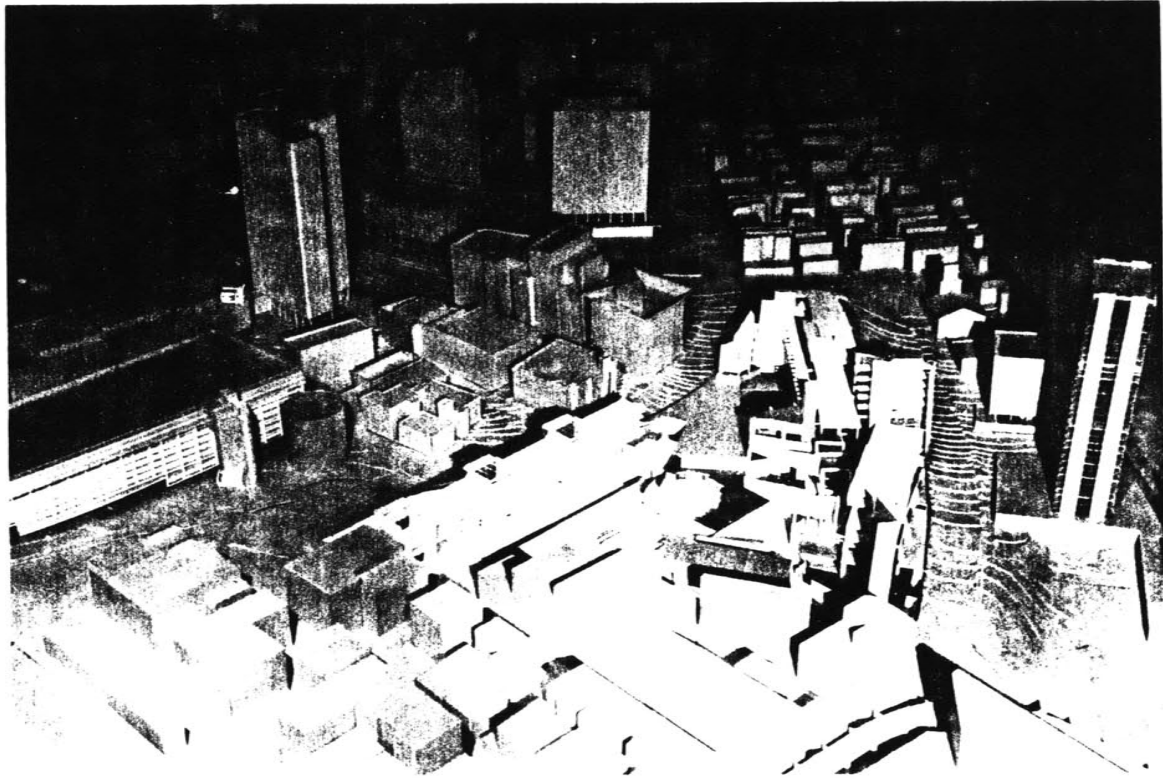

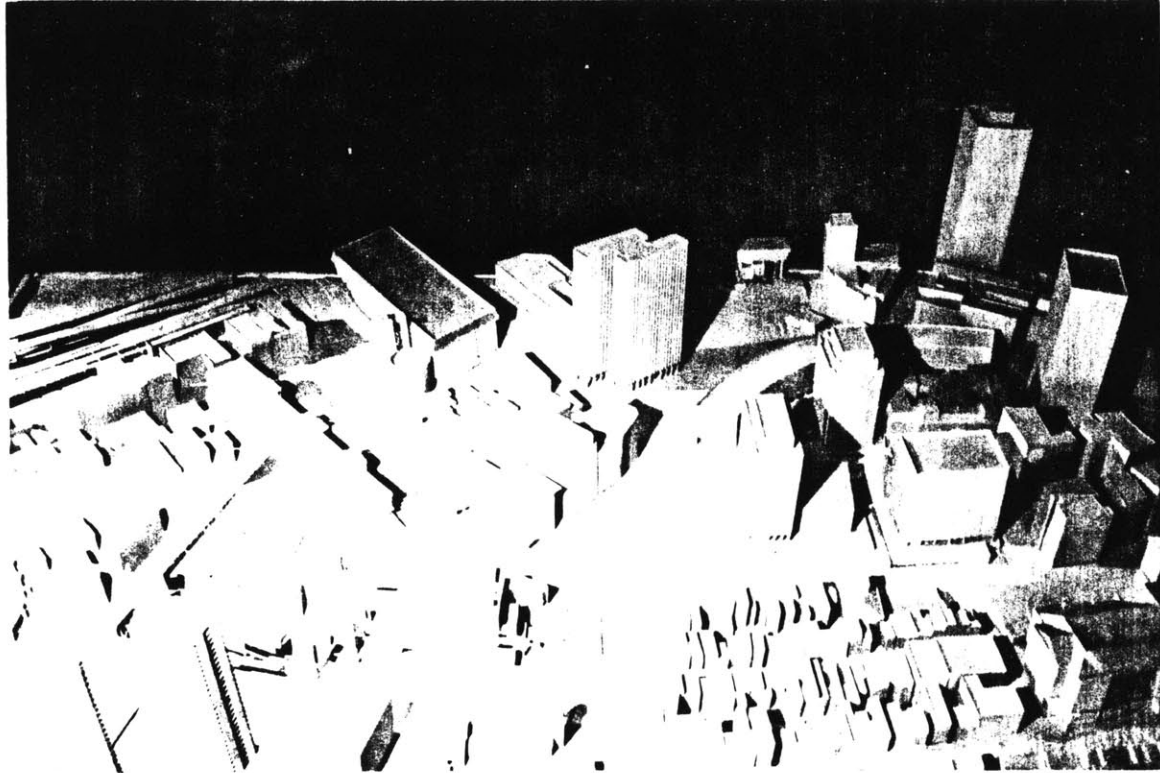

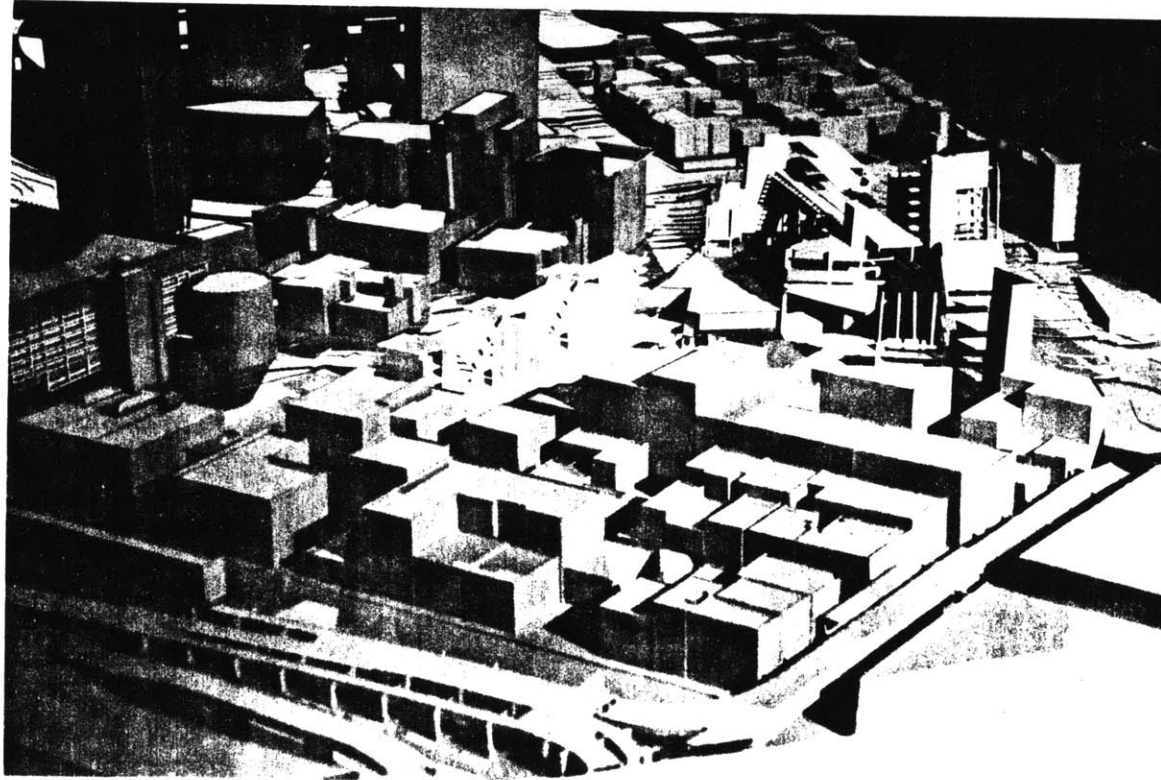

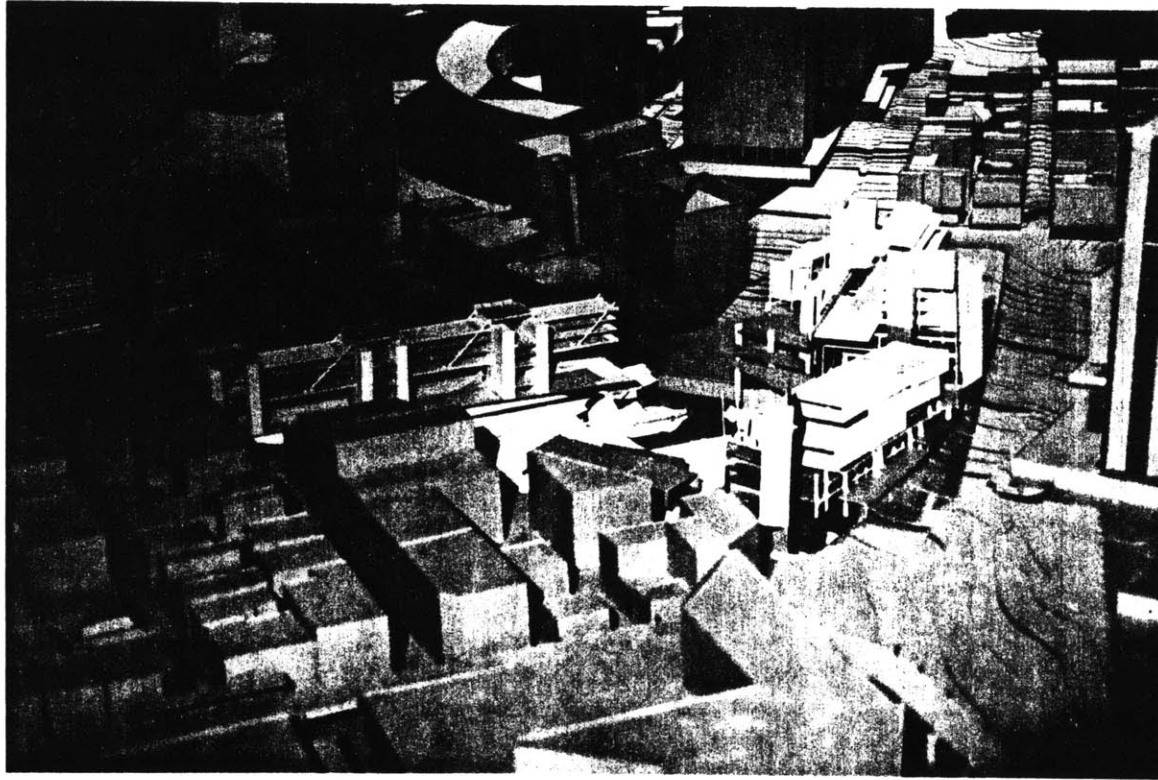

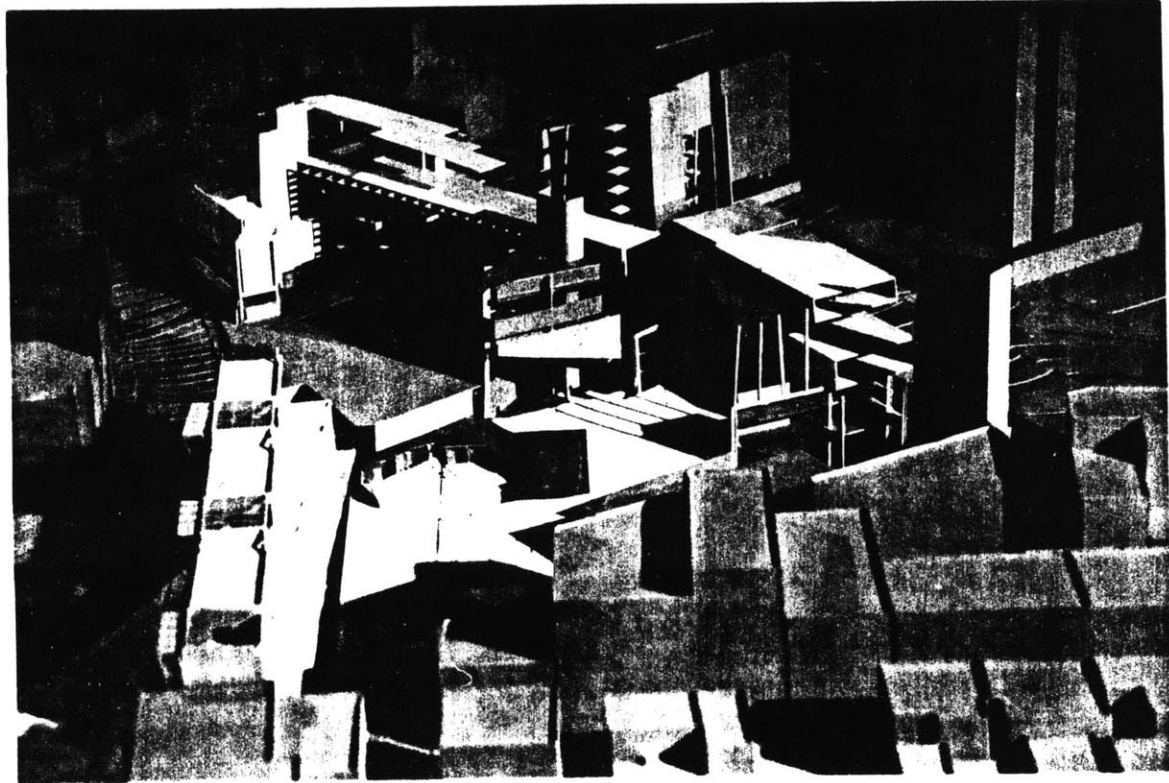

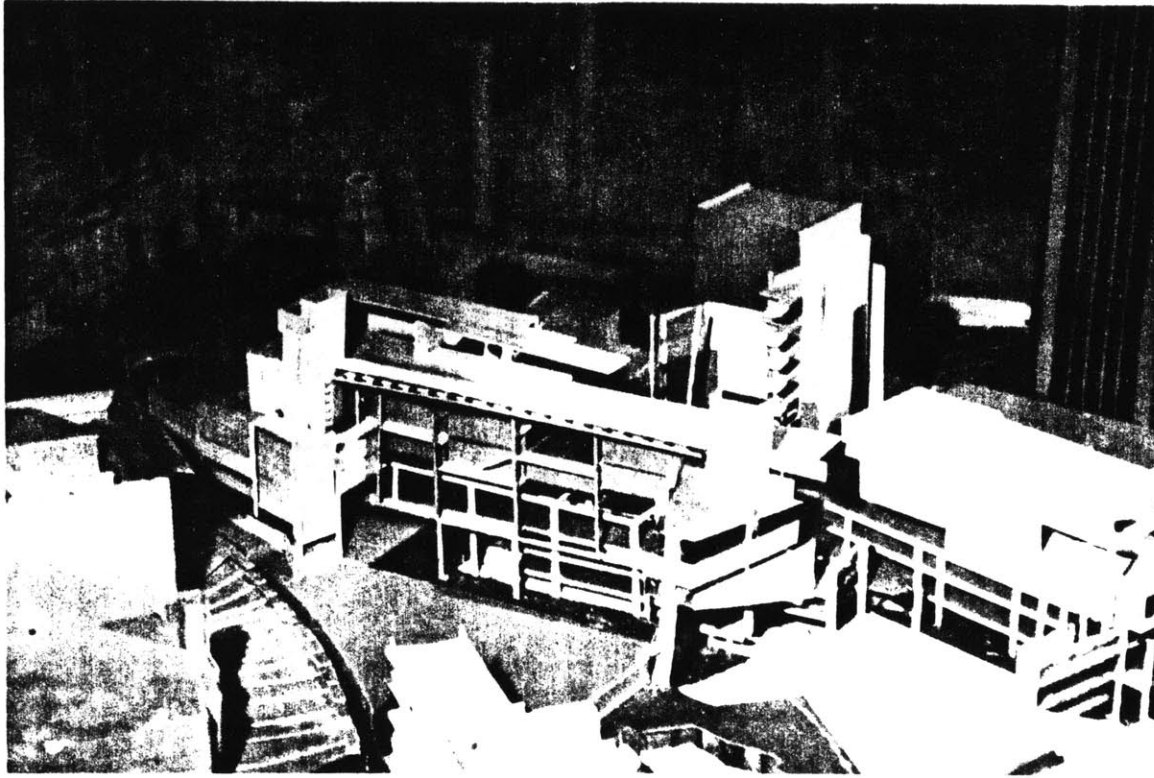

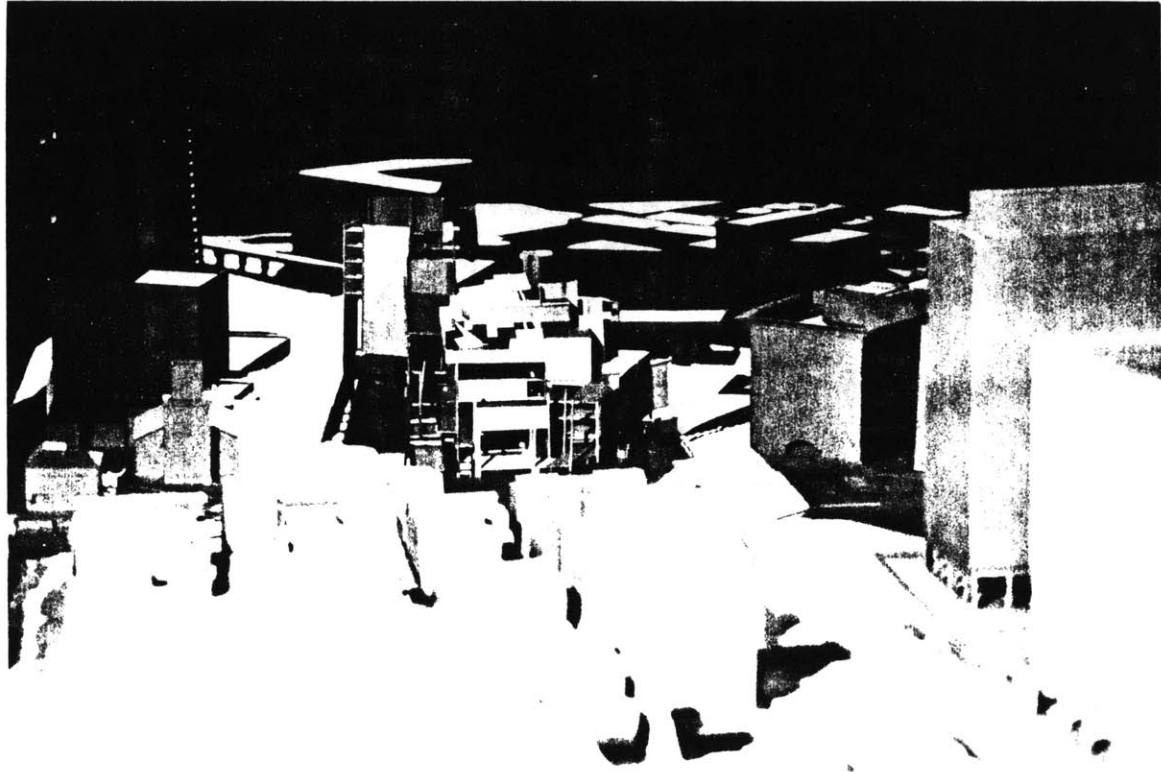

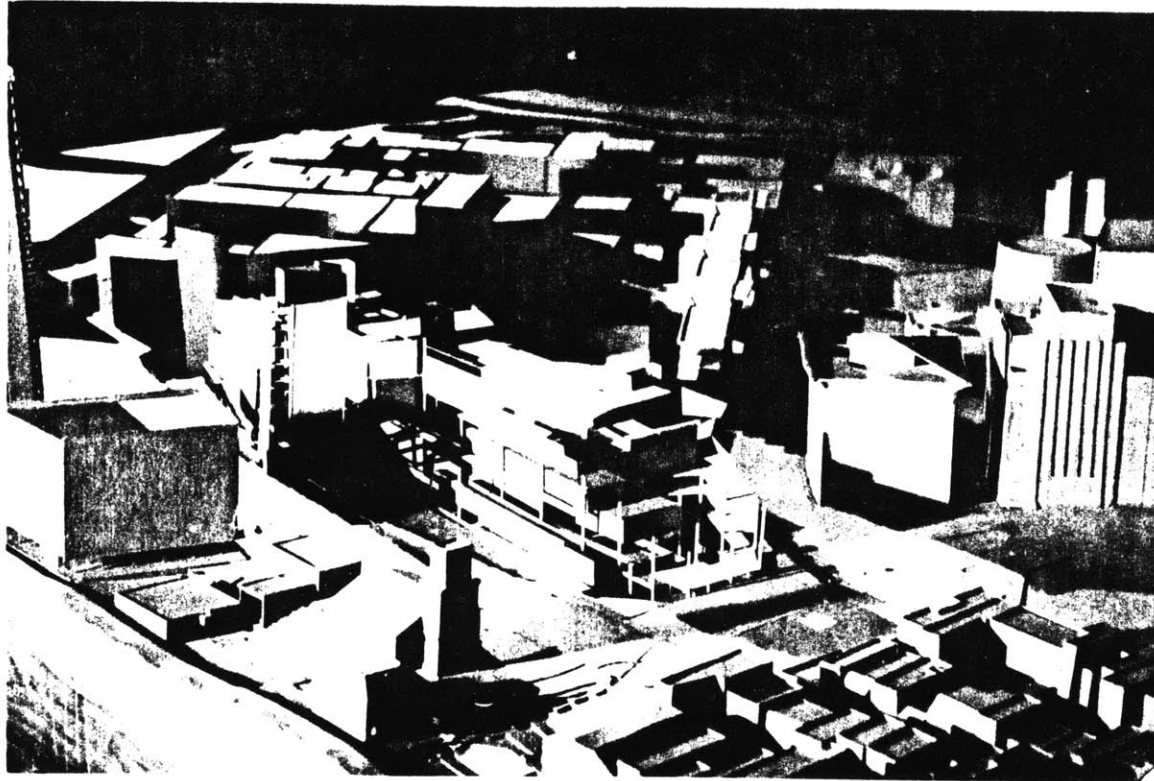

Credit for Illustrations

William R. Phillips, Plant Cast Precast and Prestressed Concrete: A Design Guide, Prestressed Concrete Institute, Chicago, Illinois. 1985.

p.89 (f.4.30)	p.390
p.90 (f.4.31)	p.365
p.91 (f.4.32)	p.362
p.92 (f.4.33)	p.51
p.93 (f.4.34)	p.52

Herman Hertzbejer, Lessons For Students in Architecture, Uitgeverij 010 Publishers, Rotterdam, 1990

p.38 (f.2.21)	p.33
p.51 (f.3.6)	p.135
p.80 (f.4.23)	p.211

Dr. Eric Dluhosch, Housing Construction Systems and Design: Prefabrication, Massachusetts Institute of Technology, Cambridge, MA., 1980.

p.94
p.95
p.96
p.97
p.98
p.99
p.100
p.101
p.102
p.103
p.104

Herman Hertzberger, Buildings and Projects, 1959-1986, Den Haag, A.
Lchinger, 1987.

p.58	(f.4.6)	p.194
p.59	(f.4.7)	p.95
p.61	(f.4.10)	p.143
p.86	(f.4.26)	p.233

Bibliography

Alexander, Christopher. Notes on The Synthesis of Form, Harvard University Press, Cambridge Mass., 1964.

Alexander, Christopher. The Timeless way of Building, Oxford University Press, New York, 1979.

Alexander, Christopher. A Pattern Language: Towns, Buildings, Construction, New York: Oxford University Press, 1977.

Anderson, Stanford, On Streets, MIT Press, Cambridge, Mass., 1986.

Anderson, Stanford. The Fiction of Functionalism, Assemblage 2 1987, pp.19-32.

Bateson, Gregory, Mind and Nature: A Necessary Unity. New York, 1979, p.86.

Behnisch & Partners, Architekten Behnisch & Partners, Arbeiten aus den Jahren 1952-1987 Edition Cantz, Stuttgart, 1987.

Colquhoun, Alan. Essays in Architectural Criticism: Modern Architecture and Historical Change. M.I.T. Press, Cambridge, Mass., 1981.

Chastain, Thomas R. Explorations of Collective Form: A Design Vocabulary Using Directional Village Forms as References, M.I.T. M. Arch. Thesis, 1981.

Dluhosch, Eric. Housing Construction Systems and Design: Prefabrication. Massachusetts Institute of Technology, Cambridge, MA., 1980.

Hertzberger, Herman, Buildings and Projects, 1959-1986, Den Haag, A.

Lchinger, 1987.

Hertzbecker, Herman, Architect, Herman Hertzbecker, IRB Verlag, Stuttgart, 1988.

Hertzbecker, Herman, Flexibility and Polyvalence, Forum XVI, 1962, no.3.

Hertzbecker, Herman, Homework For More Hospital From, Forum XXIV, 1973, no.3.

Hertzbecker, Herman. Lessons For Students in Architecture, Uitgeverij 010 Publishers, Rotterdam, 1990

Hertzbecker, Herman. Muziekcentrum Vredenburg Utrecht, Stichting Architectuur Museum, Amsterdam, 1986.

Habraken, John N. Transformations of The Site. A Water Press, Cambridge, Massachusetts, 1983.

Habraken, John N. Variations: The Systematic Design of Supports, M.I.T. Press, Cambridge, 1976.

Lynch, Kevin. Image of the City, M.I.T. Press, Cambridge Mass. 1960.

Maki, Fumihiko, Investigations in Collective Form, The School of Architecture, Washington University, St. Louis, 1964.

Mellor, David, Hertzbecker, The Centrael Beheer Office Complex, Apeldoorn, Architectural Design Press, 1974.

Mikellides, B., An Architecture For People: Shaping the Environment, London, 1980

Norberg-Schulz, Christian. Architecture and Historical Change, MIT Press, 1981.

Norberg-Schulz, Christian. Intensions in Architecture, Cambridge, Mass., M.I.T. Press, 1965.

Phillips, William R. Plant Cast Precast and Prestressed Concrete: A Design Guide. Prestressed Concrete Institute, Chicago, Illinois. 1985.

Smith, Maurice K., "Notes on Some Observable 'Facts' of Associative Physical Definition/Form"; Space and Society, Sept., 1982.

Van Eyck, Aldo. The Enigma of the Vast Multiplicity Harvard Educational Review Architecture and Education, Vol.39, no. 4, Cambridge, 1969.

Van Eyck, Aldo, Aldo van Eyck, Hubertushuis, Stichting Wonen, Amsterdam, 1982.

Van de Ven, Cornelis, Space in Architecture, Van Netherlands, 1980.

698-9