

## ARCTIC HOUSE

---

by Joel A. Turkel

Bachelor of Environmental Studies  
University of Manitoba, 1993  
Winnipeg, Canada

Submitted to the department of Architecture  
in partial fulfillment of the  
requirements for the degree of

MASTER OF ARCHITECTURE

at the  
MASSACHUSETTS INSTITUTE OF TECHNOLOGY  
February, 1999

©1999 Joel A. Turkel. All rights reserved.  
The author hereby grants M.I.T. permission to reproduce  
and to distribute publicly paper and electronic copies  
of this thesis document in whole or in part.

---

Joel A. Turkel   
Department of Architecture, January 15, 1999

---

Fernando Domeyko   
Senior Lecturer, Thesis Supervisor

---

Chris Luebke   
Assistant Professor of Building Technology  
Thesis Supervisor

---

Hasan-Uddin Khan   
Departmental Committee on Graduate Students  
Chairman

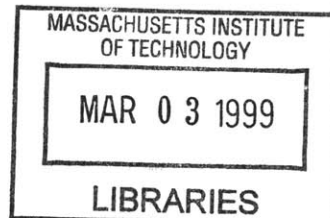

**ROTCH**

---



---

## THESIS COMMITTEE

Fernando Domeyko  
Senior Lecturer  
Thesis Advisor

Chris Luebke, Dr. Sci. tech.  
Assistant Professor  
of Building Technology  
Thesis Advisor

Edward Allen  
Thesis Reader

---

Small plane flies over the Cook Inlet, Kenai Peninsula, Alaska.

---



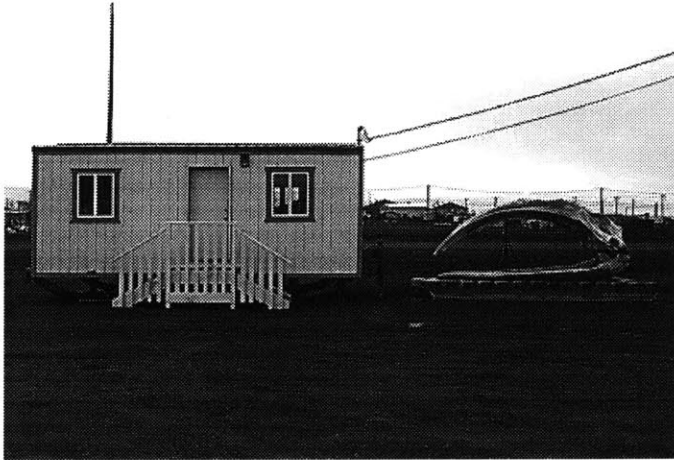

## ARCTIC HOUSE

by Joel A. Turkel

Submitted to the department of Architecture  
in partial fulfillment of the  
requirements for the degree of  
MASTER OF ARCHITECTURE  
at the  
MASSACHUSETTS INSTITUTE OF  
TECHNOLOGY  
February, 1999

Fernando Domeyko  
Senior Lecturer  
Thesis Supervisor

Chris Luebke, Dr. Sci. tech.  
Assistant Professor of Building Technology  
Thesis Supervisor

Eward Allen  
Thesis Reader

### ABSTRACT

Currently available housing in the Arctic is limited to solutions that have been adapted from designs for less severe climates. This thesis has developed a new manner of residential construction designed specifically for the Arctic climate and culture. The system invented ensures a variety of building options for traditional cultural requirements, while also improving on the level of amenity expected of contemporary dwellings. It has developed a sustainable and responsible building system that represents definite and quantifiable improvements through the use of appropriate technologies.

---

Barrow, Alaska. A portable construction shack sits beside a bowhead whale skull. Whale hunting is a large part of Inupait Eskimo subsistence hunting in the Arctic.

---



---

## CONTENTS

9	Acknowledgements
11	Introduction
13	Being in the Arctic
25	House Design
33	System Design
43	Arctic House
49	Appendix
67	Bibliography

---

Barrow, Alaska. A pre-fabricated panel home arrives ready to be assembled.  
Such homes account for 80% of new housing starts in the Arctic.

---

## ACKNOWLEDGEMENTS

---



The completion of this thesis has involved many people without whose help and support it would not have been possible. Firstly, to my parents, Drs. Turkel, whose life-long dedication to learning and teaching has been a constant inspiration, and who believed in me, even when I did not believe in myself. Thank You.

Before MIT, there were two people as deserving of gratitude as any since: To Prof. Ian MacDonald, who took a big chance – I hope you have not been disappointed.

To Dave Poiron, who gave three years of all-night(er) support. - Thanks for everything.

At MIT, I would like to thank my friends (*Urban or Suburban?!*), especially Frank Valdes: roommate, travelling companion, sometimes nemesis, but always true friend. Gracias, eh!

Finally, I would like to thank the people who helped *Arctic House* become reality : Chris Luebke, who sat and listened to a crazy idea, and could somehow see the potential in it, and whose knowledge and friendship were always welcome.

Jerry McCarty, who showed me the true Alaska, and was an invaluable resource.

Anna Thornton, who gave me her time and insight.

Eric Dluhosch, who inspired me each time we spoke.

And last, but far from least, to Fernando Domeyko, a great architect and now a great friend as well – thank you for showing me that architecture can not only exist, but that I am capable of creating it, even in the Arctic.

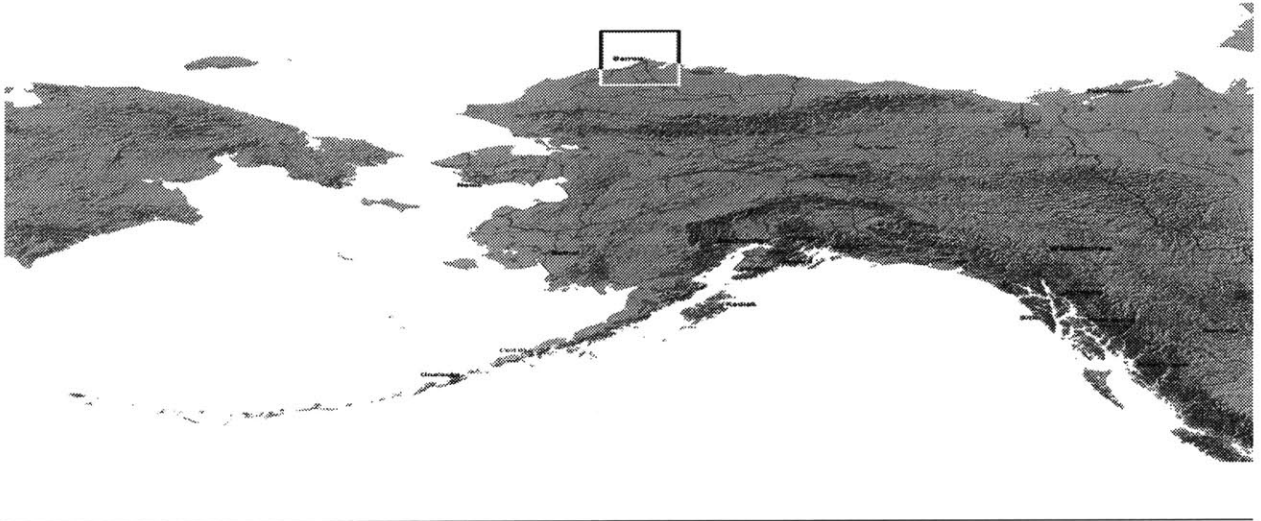

---

Barrow, Alaska. The northernmost point in the USA. 71°30'N latitude.  
(image U.S.G.S.)

## INTRODUCTION

---



Arctic House is the continuation of an investigation into the development of a lightweight, efficient and easily transported modular bearing wall system for use in cold climates, originally called the 'system wall' (see Appendix 1). The purpose for the development of this wall was to attempt to provide a method by which northern people could build their own homes more quickly, inexpensively, and with greater flexibility than they could at the present time. The 'system wall' was conceived to provide a middle-ground in the housing market between volumetric and flat-packed modular housing (mobile, modular and structural-insulated panel homes) and custom-built stick-framed homes.

The result was the seed for the Arctic House. The 'system wall' had numerous objectives that the Arctic House has also tried to attain throughout its development. While these objectives were useful to guide the development in its early stages, they represented only quantifiable issues that pertained to the system of the Arctic House. They did not provide the essential information regarding the manner of home the system should be capable of creating in the Arctic. In short, what was missing in the development of the 'system wall' were the architectural constraints that were to guide the Arctic House.

To design a good housing solution for the Arctic, one would need to truly understand the Arctic as a place, and the predicament of the people living there. So, in August 1998, I went to Barrow, Alaska.

---

Terrain surrounding Barrow, Alaska. The North Slope Borough is situated on the frozen remains of an ancient peat bog. The topography still has a high water content as can be seen by the thousands of pothole lakes, whose surfaces melt in the summer sun.



---

Midnight in Barrow, Alaska. Young people head home from the youth center.





The expense of living in Alaska, and specifically in Barrow, is in no small part due to Alaska's long history of technological and resource dependence on outside sources, primarily from the contiguous United States. This dependence has a number of negative ramifications on people living in these areas. Perhaps the most significant of which is the fact that dependence ensures a higher cost of living, and is generally indicative of an underdevelopment in local manufacturing.

While the expense of living in Alaska is closely related to the fact that virtually all goods must be imported at great expense, the increased distance and remoteness of the Arctic only makes the situation more pronounced.

Virtually any product can be purchased in Alaska, provided one is willing to pay high shipping premiums. Most products in Alaska are priced considerably higher than elsewhere in the United States, due to transport costs on products not manufactured locally.

Surface freight charges from Seattle to Anchorage on building supplies range from \$6.70 - \$13.25/100 pounds, depending on length<sup>2</sup>. These premiums can be added directly to wholesale prices paid on the same product in Seattle, and the costs get progressively higher as the freight is moved further into the Arctic. For example, the current cost of transportation on a 1000 sq. ft. Structural Insulated Panel home (SIP) via barge from Seattle to Barrow is \$40,000, approximately 40% higher than the cost of the same house F.O.B. Anchorage.<sup>3</sup>

Local people accept the problems associated with the barging and airfreight

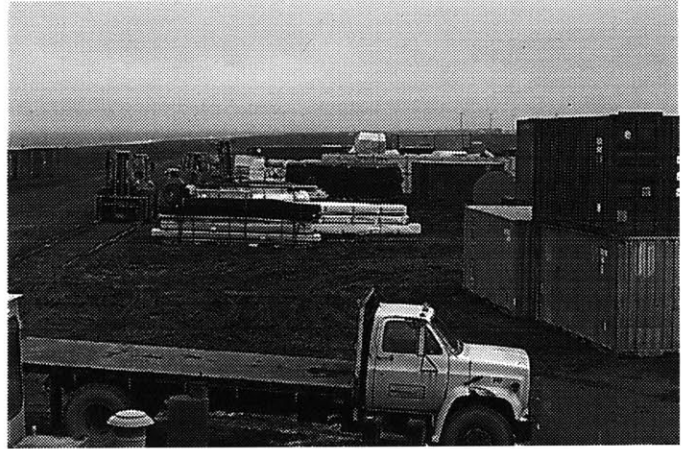

<sup>2</sup> Alaska Market for Value-Added Lumber Products, pg. 34.

The shore of the Arctic Ocean five miles north of Barrow. The containers on the beach were left only days earlier by the annual barge. The trucks will work around the clock delivering goods before the weather becomes impassable. bottom: Eggs for sale in a Barrow supermarket, where the cost of living is the highest in the nation.



systems in use in the Arctic as a fact of life. In Barrow, supplies arrive once a year on barges that have a two-month window to deliver goods while the Arctic ice pack is out. All other goods must arrive via airfreight. Barrow is serviced year-round (weather permitting) by a landing strip. It is at present too expensive to consider airfreight as an option for building materials, due to the difference in cost between air and sea freight. There are, however, a large number of sites in the Arctic which have only air access, and many of these are only accessible by helicopter. This inaccessibility of Arctic regions is largely caused by the harshness of the climate.

The Alaskan climate is generally severe, but it is especially so in Arctic and Continental Alaska. These regions can experience maximum winter lows of  $-75^{\circ}$  F, with summer maximums to  $100^{\circ}$  F. Unlike the Pacific coast of Alaska, these regions are also very dry. The annual mean precipitation for Barrow over the last fifty years has been 4.5 inches, making it almost twice as dry as Phoenix, Arizona over the same period.

Building supplies wait on the beach. Such materials figure heavily in the annual cargo.

<sup>3</sup> Peterson, C.

---

All sunlight in Barrow is received at oblique angles. The maximum summer sun angle in Barrow is 41 degrees. In the summer the sun remains continuously above the horizon for 85 days. In contrast, in the winter, it remains continually below the horizon for 67 days.

One of the most significant climatic issues is that of wind. The direction of the prevailing wind in Barrow is roughly NNW, coming from the direction of the polar ice cap. These winds can gust to 80 mph during winter storms, and bring a considerable amount of driven snow. Even though Barrow has one of the driest climates in North America, the sheer size of the polar ice cap, when combined with the virtually unfettered polar winds, makes snow drifting a significant issue. The town of Barrow is completely surrounded by snow fences twenty feet in height to reduce the amount of snow accumulation on streets and buildings. These climatic considerations have not only a great impact on what can be built in Barrow, but also *when* it can be built.

The building season in the Arctic can be as short as two or three months. The precise time available can vary dramatically from year to year, depending on the severity of the winter. Builders in Barrow informed me that the current preference for SIP systems is based on the fact that an average crew can get a building to lock-up within 3-4 days (exclusive of foundation work).<sup>4</sup>

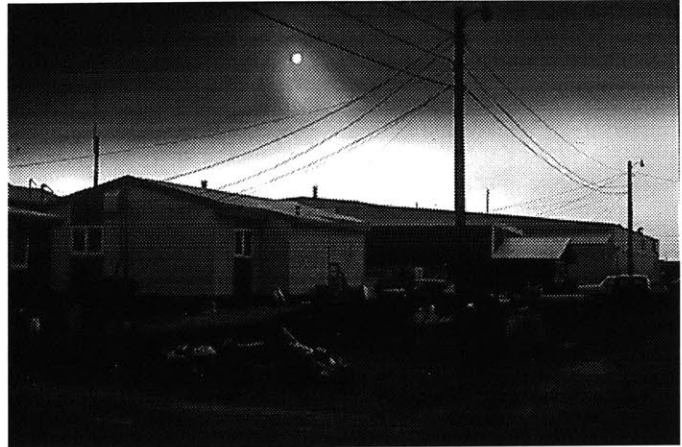

---

<sup>4</sup> Brewster, D.

Midnight in Barrow. The summer sun climbs to only 41° above the horizon and remains visible continuously for 85 days.  
bottom: A twenty foot fence surrounds Barrow, keeping snowdrifts from clogging the town.



While time continues to be a major factor, the significance of cost has prevented pre-fab volumetric homes such as mobiles from being as commonly used as SIPs. The cost of shipping such a home can be 50% higher than an SIP home due to the increased size and fragility of the units.<sup>5</sup>

At present, more than 80% of new homes constructed in Barrow are SIPs. The SIP home is assembled from a kit of parts shipped up several months in advance, usually from Seattle. Individually packaged homes are delivered to building sites in the community throughout the building season, and they are rapidly assembled by a labor force that is comprised largely of tradesmen from outside of Barrow. Several crews will be involved in the assembly of each home, one for each stage in the process.

The first crew is responsible for placing the large wooden piles that will become the foundation for each home. Foundation pilings are usually positioned a year in advance, because the time required to set them can take an entire building season. At close to \$3,000 per pile, the expense of creating a foundation can be so high, that many families will have piles set, and wait several years to put a house on it.

Other crews will then proceed through the process of decking, SIP assembly, finish carpentry, etc. The net result of this process is a completed home designed for virtually anywhere, manufactured in Washington State, shipped at great expense, assembled by imported specialized labor, set



---

Mobile homes unloaded from the annual barge await shipment to their sites. Some will remain in Barrow, and others will be transported to nearby villages. bottom: Pilings set several years earlier await a home. The high cost of home ownership causes some families to wait years before building.



---

on an expensive foundation, and provided for consumption at \$240.00/sq.ft., more than three times the cost of the same home almost anywhere else in America.

Many individuals in Barrow have purchased homes for which they have not received satisfactory maintenance. Since many homes are prefabricated, they come with warranties that are not always honored. I met one man who purchased a home from a Seattle manufacturer, only to discover after he had considerable problems with it, that the manufacturer's warranty was voided because he had built north of 55 degrees latitude. Arctic people are very skeptical of systems they cannot have locally repaired, or that they cannot repair themselves.

The problems associated with systemic failure in the Arctic are caused almost exclusively by envelope disruption due to a lack of system flexibility or rigidity. Differential settling due to frost action causes panels to pull apart not only because joints are not strong enough, but also because systems do not work sufficiently as such, but rather as assemblies of nearly autonomous units. Minute cracks can lead to extensive water and ice damage caused by moisture-laden indoor air being forced between wall assemblies by air-pressure differentials. Indoor temperatures of 60-70° F can lead to winter differentials approaching 140° F.



---

A construction worker assembles the floor of an SIP. These homes can be ready for interior finishes in as few as three days.  
bottom: For Sale: \$240,000 - A new SIP home in Barrow awaits its occupants.



Air-tightness is very important, but it can lead to problems associated with indoor air quality. In a climate as dry as Barrow's, moisture content is also important, but the primary concern from a health standpoint, is ensuring sufficient air changes.

Boyd Morgenthaler, P.E., a mechanical engineer at Adams, Morgenthaler and Co. in Anchorage, informed me of several performance criteria he felt were required for the Arctic. He said that ASHRAE 62/89, which calls for 15cfm per person, only translates to approximately 0.35 air-changes/hour in a typical house. He felt that this was inadequate, and was too tight as a standard for a house used on a room-by-room basis. In contrast to these standards, he told me a good house for the Arctic would need one air-change/hour of outside air in conjunction with four air-changes/hour minimum of air-circulation. These parameters call for increased mechanical systems, or a completely different approach to housing in the Arctic.

The larger towns, such as Barrow, have access to natural gas, which is provided from the nearby oil fields, and is brought to the houses by the Utilidor system. This infrastructure is part of huge public works projects underway in the Arctic. These projects have developed the Utilidor network, which is a system to provide sewer, water, electricity, and natural gas to each building site. The initial cost of this infrastructure in Barrow was \$349million. System upgrades to date have raised its cost in excess of half-a-billion dollars to service less than 4000 people.<sup>5</sup>



Utilidor piping waits to be used to expand the existing system.  
bottom: Access hatches for the underground Utilidor network are located at many street intersections. The system provides gas, sewer, electricity, and pre-heated water to Barrow's 3900 residents.

<sup>5</sup> Hendrickson, T

---

Like all resources in the Arctic, labor is also in short supply and high demand. This of course leads to very high labor costs. It is not unusual in Barrow to pay \$30/hr. for unskilled laborers and twice that for carpenters and other journeymen. During the prime construction times (June-September) the services of these tradesmen are oversubscribed. A large majority of these are entirely seasonally employed, both amongst the locals who remain through winters, and among those individuals who go to the Arctic only for the building season. All trades are represented during this period, including framers, roofers, finish carpenters, equipment operators, pipe fitters, plumbers and electricians.

One of the primary reasons for visiting the Arctic was to gather information about the culture that could help influence the development of the Arctic House.

One man I spoke to for some time was an Inupait Eskimo elder named Fred Bahr, who was very eager to help me try to understand the particular housing needs of his people.

He informed me that it was not unusual for Eskimo people to sleep as many as twenty people in one large room. He told me that they did not approve of small, compartmentalized spaces typical of Western housing.



---

Geodesic home in Barrow. People in the North prefer large living spaces with overhead light and curvilinear forms.



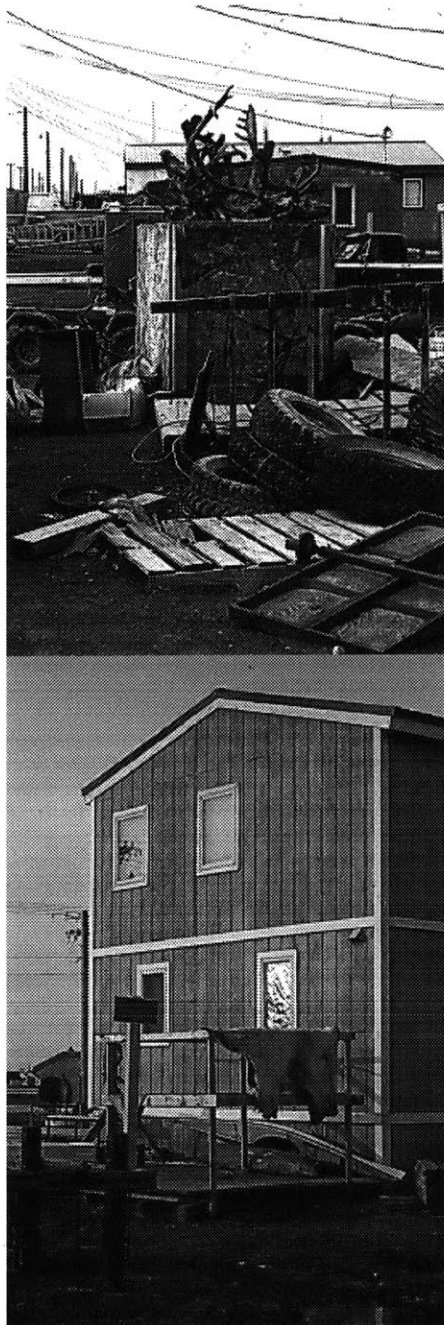

He told me a story about a house he once owned in Fairbanks, that had a living space with high ceilings and a clerestory. One winter a group of relatives and friends come to stay with him for a few days. They enjoyed sitting in his living room and talking so much that they stayed for two months. The point of his story was that Eskimo people feel a connection to large, tall rooms with light coming from the direction of the sky. Rooms such as this facilitate Arctic culture, which over centuries of extended and brutal winters, has developed into one which focuses on sitting and sharing stories and friendship in large groups. These meetings would often last as long as a storm did or the weather was impassable.

In keeping with this culture, he told me that a kitchen should be large enough to cook for 20 persons. He also told me that Eskimo people require a *hunisuk*, which is a large enclosed but unheated space adjacent to the house. The purpose of this space is to have a place to dress game such as caribou, store foodstuffs away from scavenging animals such as bears, and to perform maintenance tasks on snowmobiles. Subsistence hunting is still a huge part of Eskimo life, so he felt the *hunisuk* to be one of the most important programmatic elements of any good house in the Arctic. He asked for a room roughly 10 by 20 feet, and said that this room would also ideally serve as an entry porch.

Two common sights in Barrow: A pile of caribou antlers sit out of the reach of dogs, and a polar bear skin hangs to dry high on a porch. Subsistence hunting is a way of life in the Arctic.

---

The most interesting thing that he related was the fact that Eskimo people laugh at 'Western' houses because they do not have a *chugee*, or nose. He said that Eskimos feel that the house has a life and a spirit like all things, and as such should have a manner of breathing. He told me that all traditional native dwellings in the Arctic have such a device, which enables the occupant to allow air to pass up and out. It allows cooking odors to be replaced by fresh air, and is always located high in the living/cooking space. His description was remarkably close to the technical description of what was required for proper air circulation as described to me by Boyd Morgenthaler.

Mr. Bahr also told me that Eskimo people had no affinity for 'boxes', and that they preferred 'flowing lines'. He said that such configurations were more descriptive of connection to the earth. He spoke of so-called 'native-housing' in rather unflattering terms, considering these houses to be foisted upon his people and completely disconnected from Arctic culture. He expressed a strong desire to see a house that would incorporate emerging technologies. He informed me that his people were aware of the importance of having their children become adept in the use of these technologies.

The overwhelming impression I got from Eskimo people is that they have a strong desire to attain autonomy, but will not do so at the expense of their old ways.



---

An attempt at self-housing offers up some commentary on the forms preferred by people in the Arctic. The house is spray insulated.  
bottom: Quonset huts remain courtesy of a closed Naval base.



---

A garage in Barrow combines a faceted curvilinear form with an easily assembled and cheaply transported flat-packaged kit-of-parts.

---

## HOUSE DESIGN

---

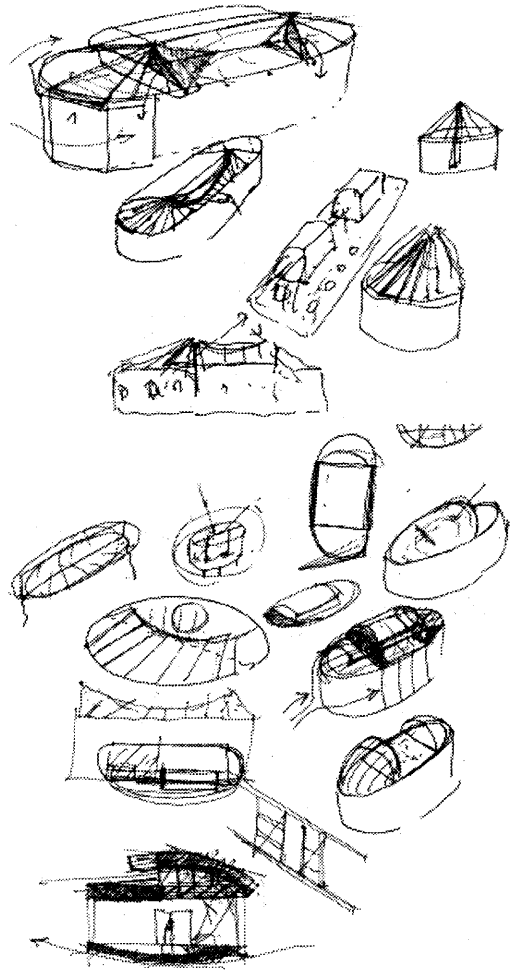

After returning from the Arctic, I had a great deal of information as to what the Arctic House needed to accomplish. What remained was the greatest challenge: How could these requirements be manifested into architecture?

In short, how could I create space that was more suitable to life in the Arctic?

---

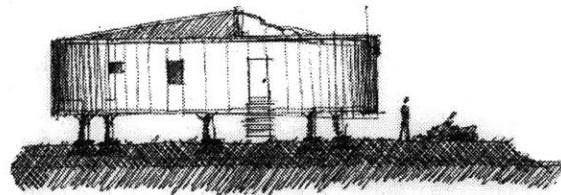
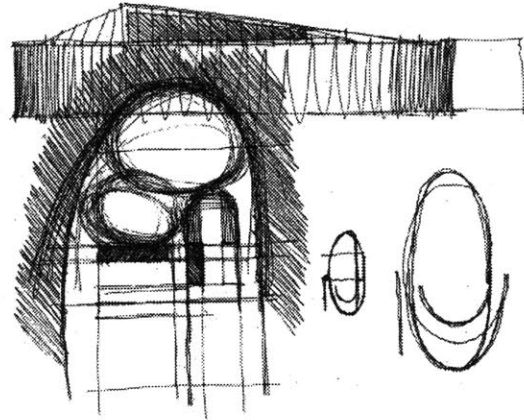
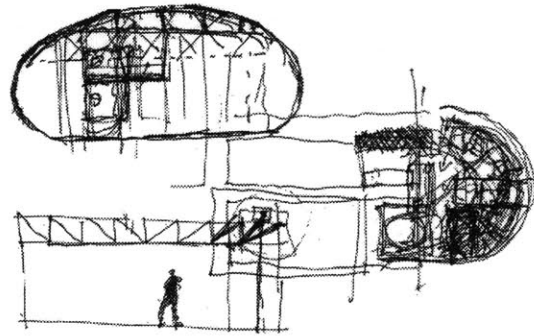
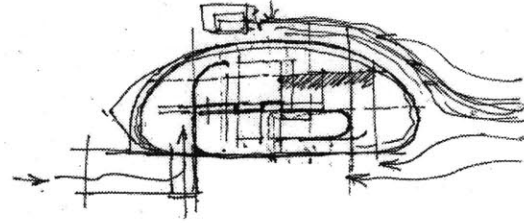
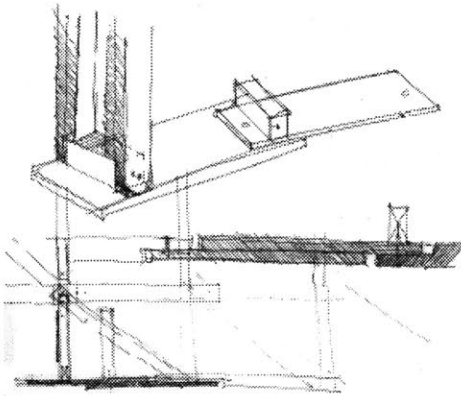

I had talked to people about how they lived, what they wanted and needed, now how could this information be used? How could the hardship of the Arctic be understood and designed for in a home? Could the culture of staying inside for weeks in large groups be accommodated in a home that also needed to be used the remainder of the year for a family of four? Could a house even be livable if one needed to remain indoors virtually all of the time? Was there a way to make interior space somehow engage a vast inhospitable natural world? Could this be accomplished by creating a house that could somehow be engaged in its entirety during day to day use? Could functions, and their traditional (western) positions be challenged and changed to re-describe how a house should be used?

---

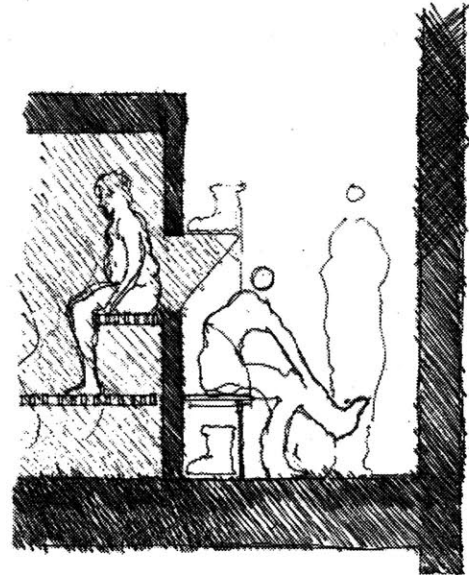
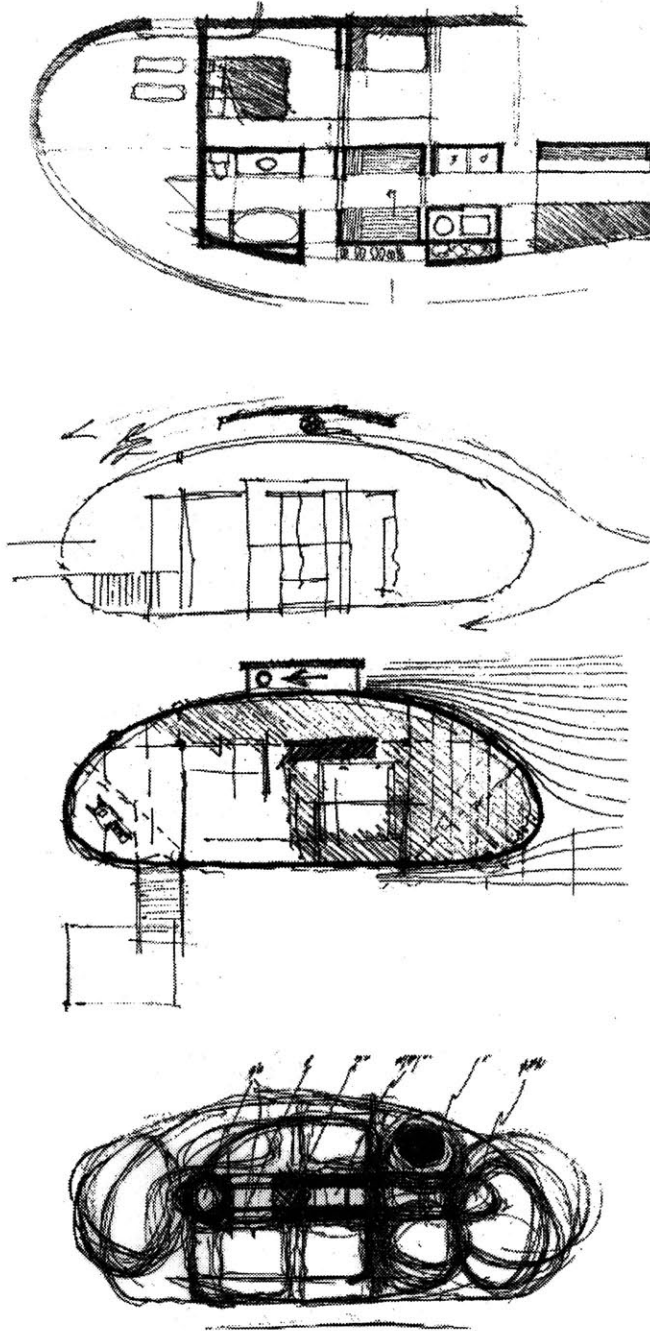

Would that new description be the result of understanding how the Eskimos prefer to live?

In a culture comfortable living and sleeping in large groups, would it be conceivable that the house could become a series of interconnected and open places? Could these places undergo transformations if privacy were required or desired? If the Eskimo preference for dwellings with flowing lines stemmed from a centuries-old understanding of how air, warmth, and people circulate most effectively, was it possible that a more open plan would facilitate these circulations, leading to a more efficient and healthy living environment?

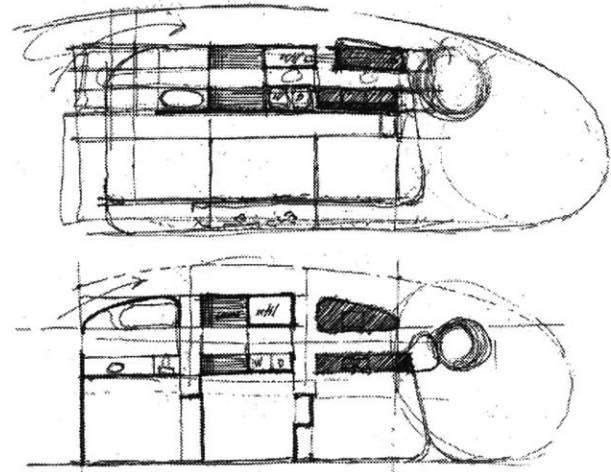
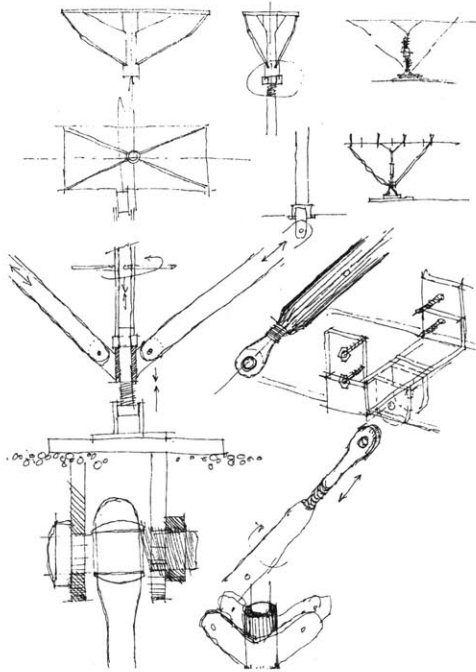

If a *bunisuk* were to be used to accommodate the need for protected yet unheated storage and work space, and if it were to double as an Arctic entry, could this not begin to establish a method of protecting heated space from exterior space? Could this thinking extend to further subdivisions between cold and warm? Could this begin to create a relationship between spaces for circulation, living, storage, and services. What would these relationships be? Would they represent a method of understanding how the house could improve the quality of life in the Arctic?

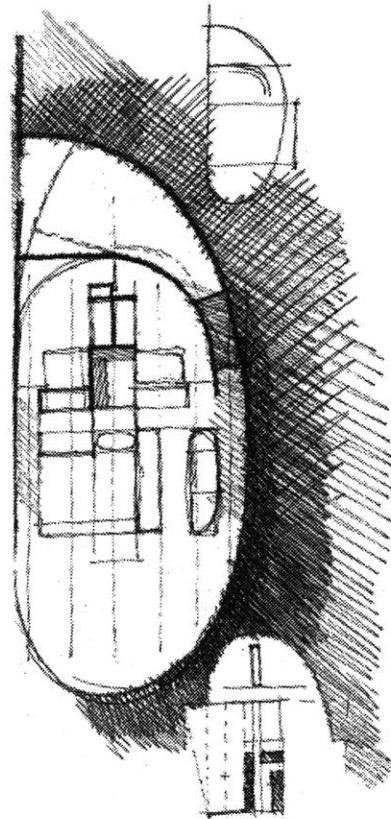



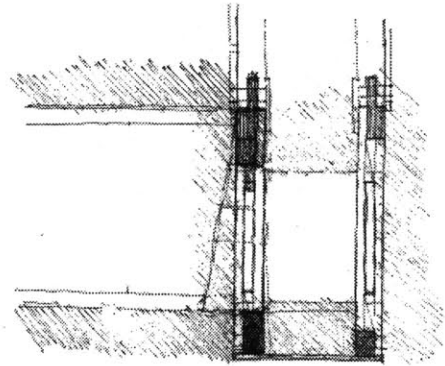
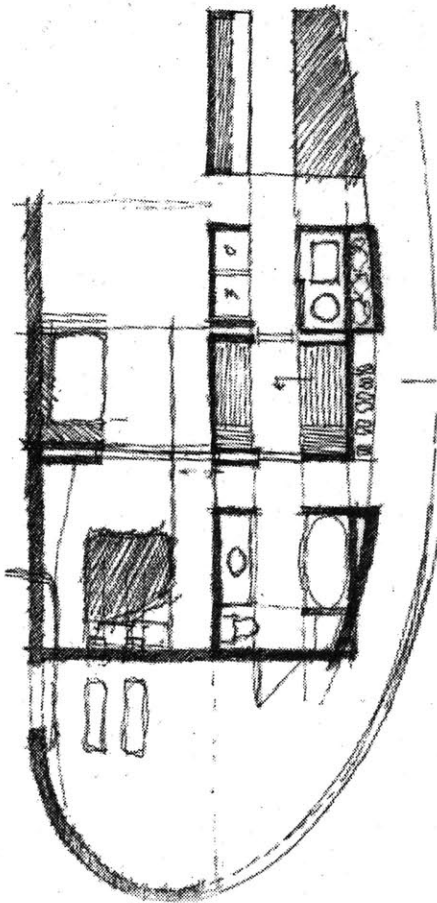
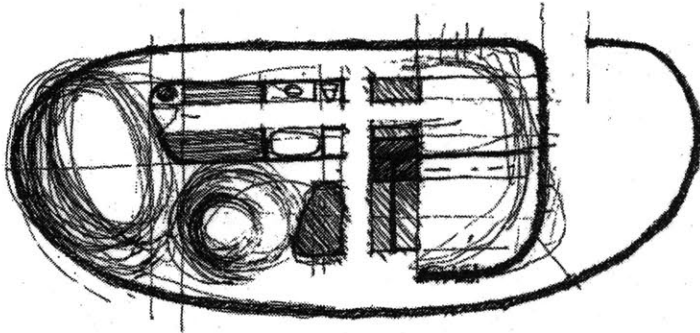

Was it possible to create sleeping areas in the center of the house, as far from a potentially cold perimeter as possible? Was it feasible to place services in the center of the home along a central spine? Could these services not include all things that may generate heat: furnace, laundry, kitchen, shower, sauna? Could this spine not be accessed in a number of ways so that the day to day use of the facilities could activate the entire house? Wouldn't this also mean that the house would be experienced differently from day to day as well? Would this enable the people of the house to extend their interaction with it, thereby also extending the perceived boundaries of the house? Could these perceived boundaries also be affected by the form of the house?

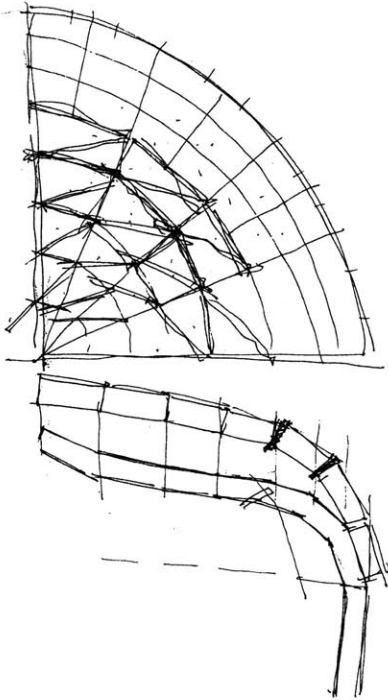

If the desire was to increase the sense of where those boundaries lay, should the house take on any hard definitions of space?

Would the manner of the organization of spaces and circulation begin to suggest that form?

What would this form be?

Was it possible that the form could also respond to the particular daylight conditions of the Arctic?

Could it open up somehow to receive the low angle of light that falls in the Arctic?

Could the manner in which this light enters the building be designed in such a way to benefit the whole house, rather than just rooms facing the sun?

---

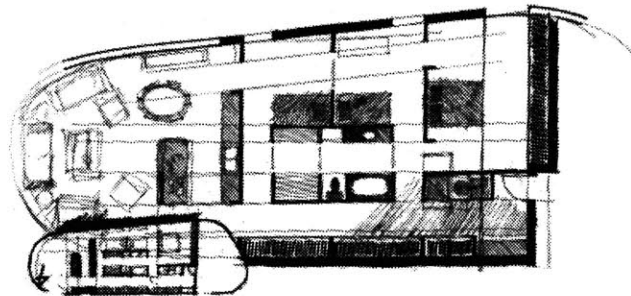
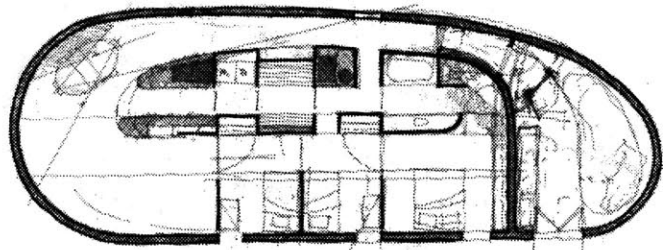
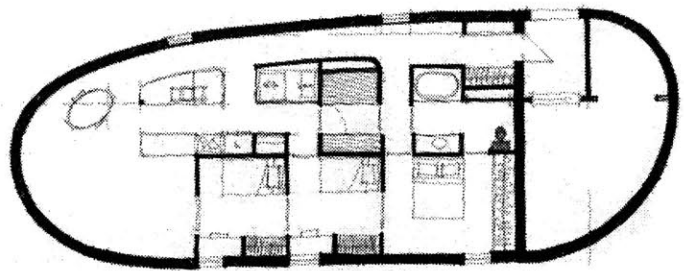
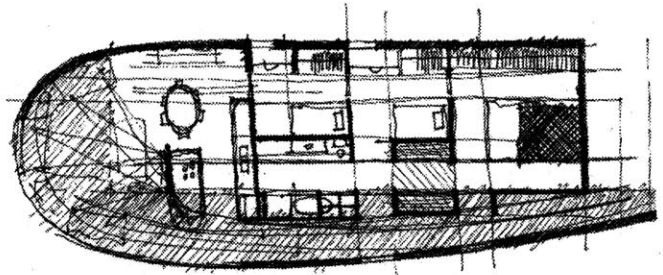

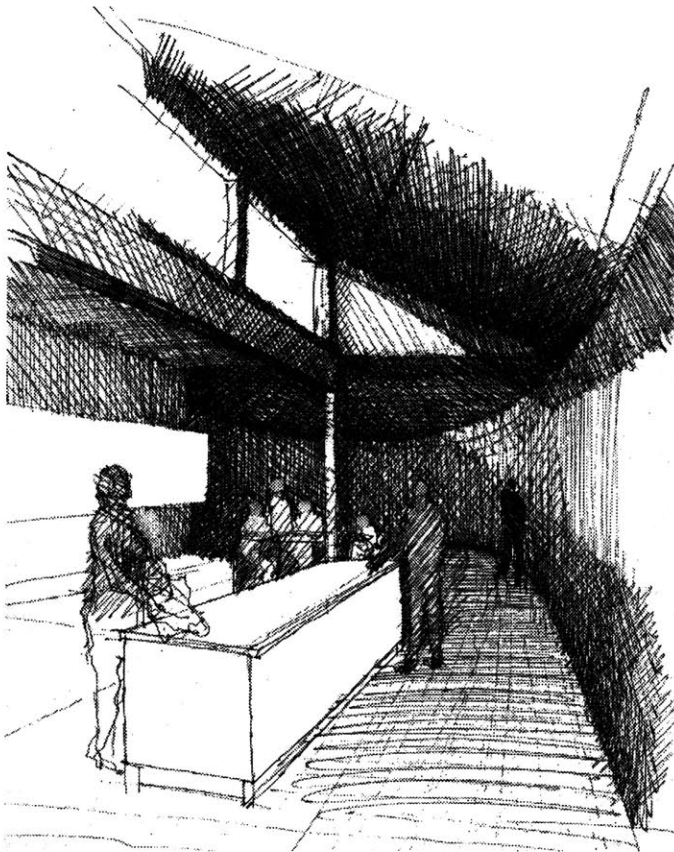
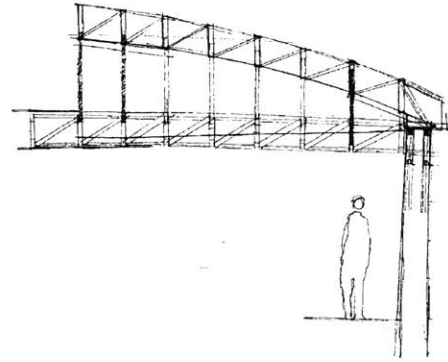
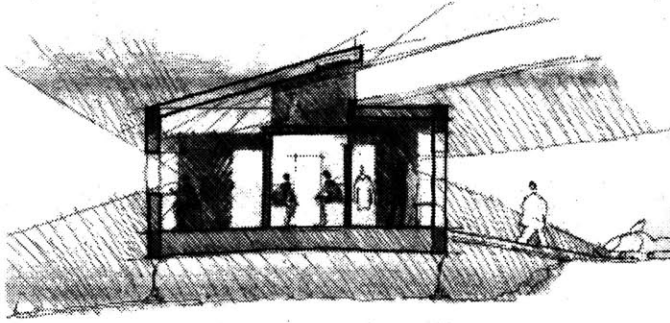

With the extremely low sun angles of the Arctic, would it be best to allow light to enter the house and be reflected down from above?

Could this be accomplished by the use of a clerestory that could bring light to the entire house?

Was this type of light in keeping with the requests made by natives? A light that entered from above, and by reflection made the room akin to the natural world outside?

Would this form also be the best for wind resistance? For snow deposition?

Would it be possible to make this form and this house in the Arctic?

Could it be made of available materials?

Were there methods that had not been explored yet to construct in the Arctic?

Could this form also satisfy other requirements of building in the Arctic?

---

**SYSTEM DESIGN**

---

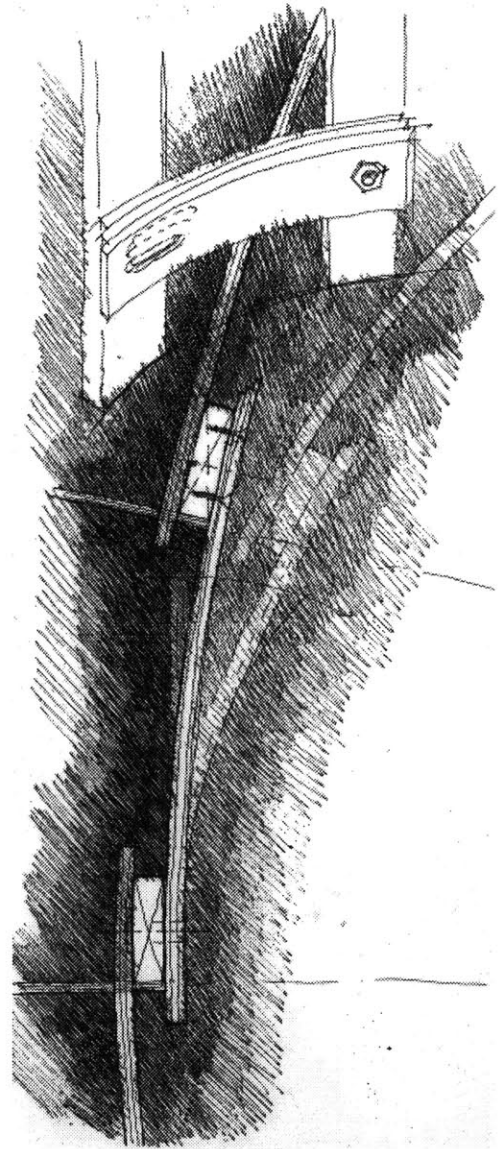

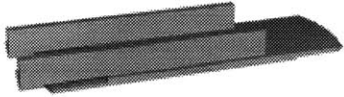

Base units interlock to establish the curve that the wall will assume. The units can take on any curvature, and their length of 32" is determined so that the wall may be sheathed with 4x8 panels.

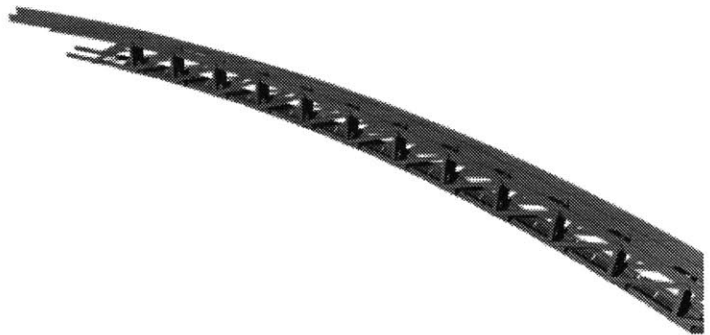
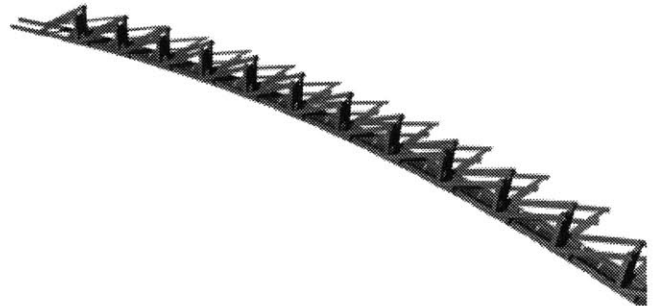
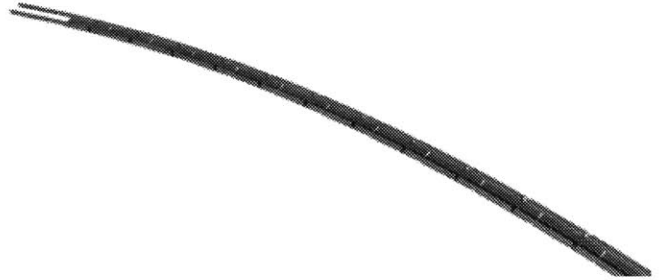
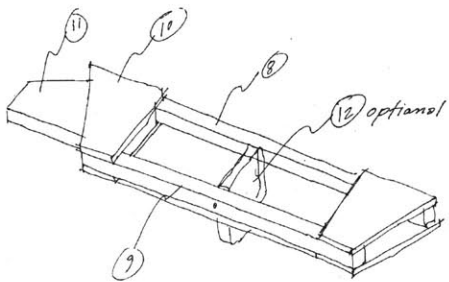
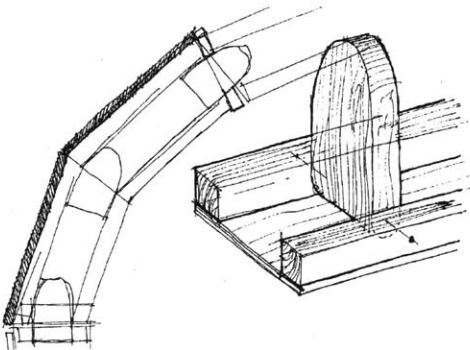
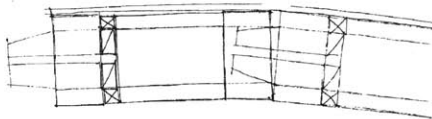

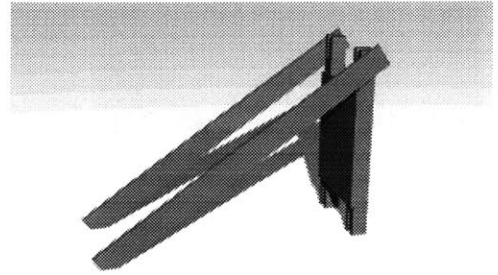
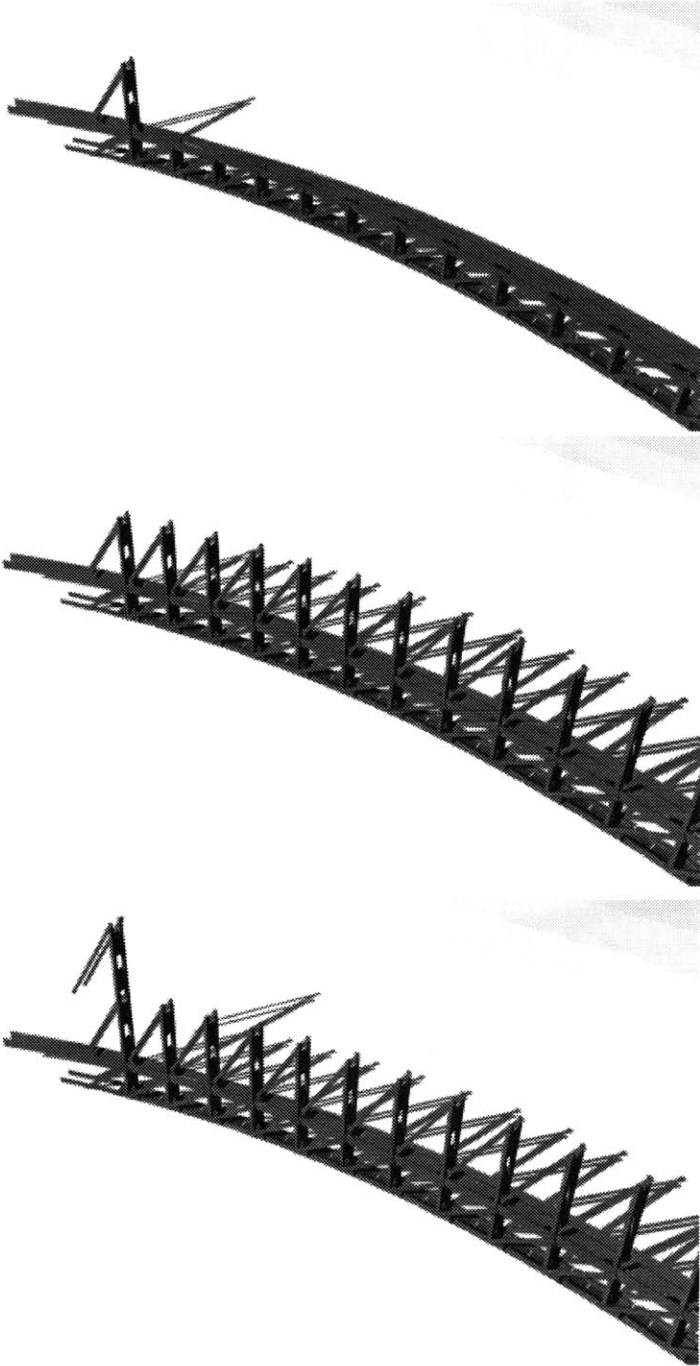

After the base units have set the curve and are secured together, the A-units are added. These are positioned one at a time, until the entire first course is complete.

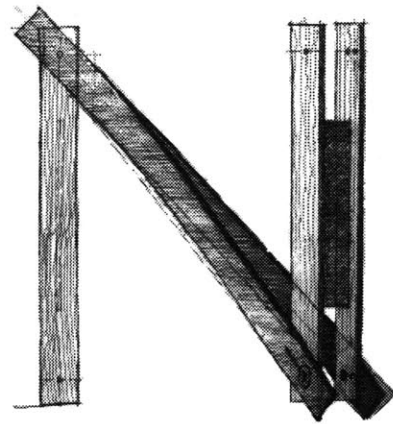
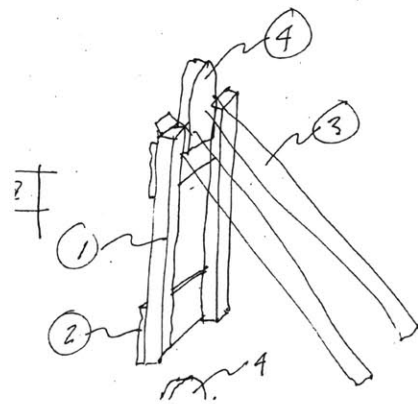

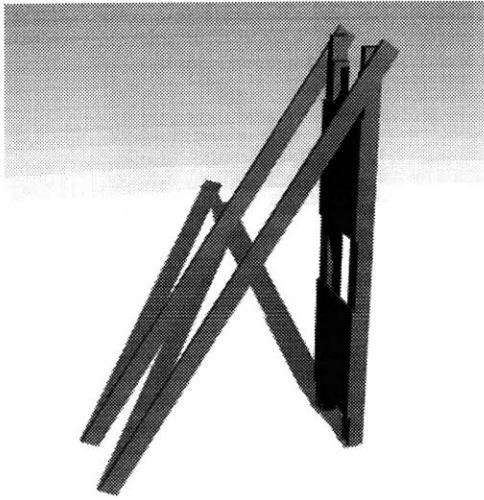

The B-units are placed on top of the course of A-units. These Units are 48" in height, again allowing the use of 4x8 panels while reducing the number of joints in the wall.

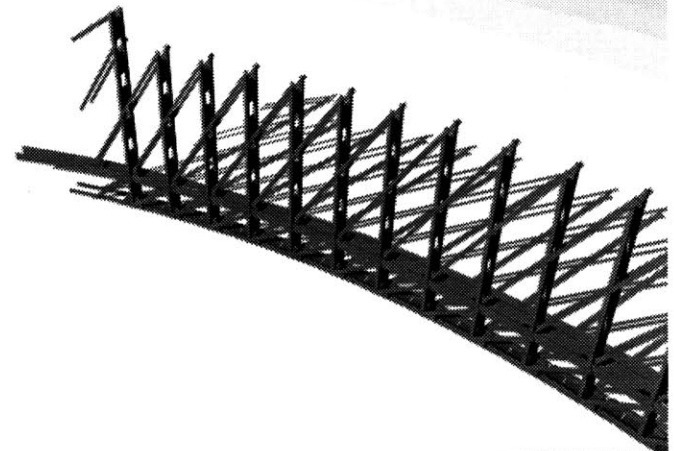
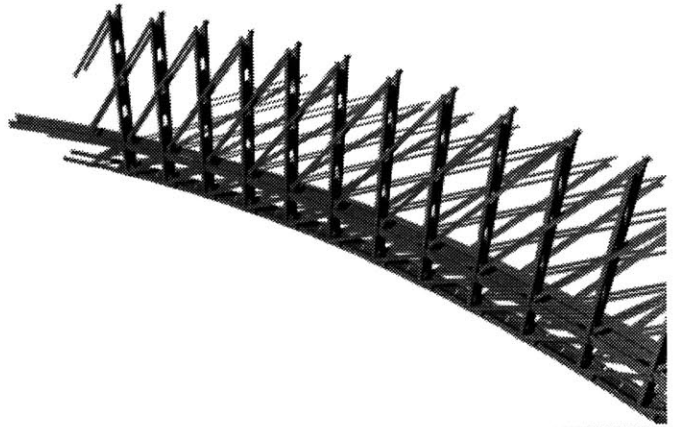
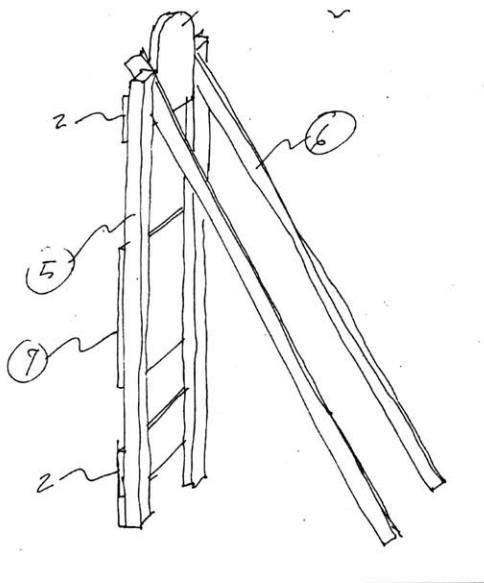



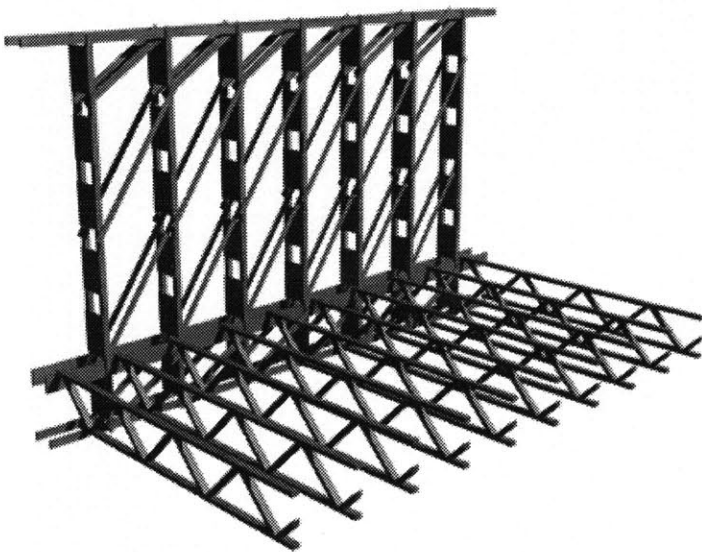

The top of the second course of A-units is finished with another string of base plates, this time inverted and acting as top plates. Because the wall of the house acts as a perimeter beam when the form is closed, these two courses of B-units act as a web which can be perforated for doors and windows, while the string of base plates act as the bottom tensile chord of the beam. A portion of the completed wall is shown at left, with an early suggestion of how the floor may connect to the bottom course of A-units.

---

---

The revised system model. Here the various units that will construct a small section of the Arctic House are shown in their flat-packed state, as they would arrive at the building site. They are four varieties of units required for this particular building.

The Base-units are broken out and deployed. Once on the ground, they are positioned into the curve they will take and nailed together. Then the connecting flaps are raised. The wall is now ready for the A-units.

The A-units are positioned as required on the connecting flaps. They are nailed into position - both to the flaps and to each other by use of their diagonal bracing. The triangulations of their forms make them very rigid. Their male ends are positioned upwards, and can slip between the rails of a second row of Base-units. This row of Base-units closes the first course and creates a beam 24" deep. This beam encloses the perimeter of the house, and acts as the basis for further construction.

---



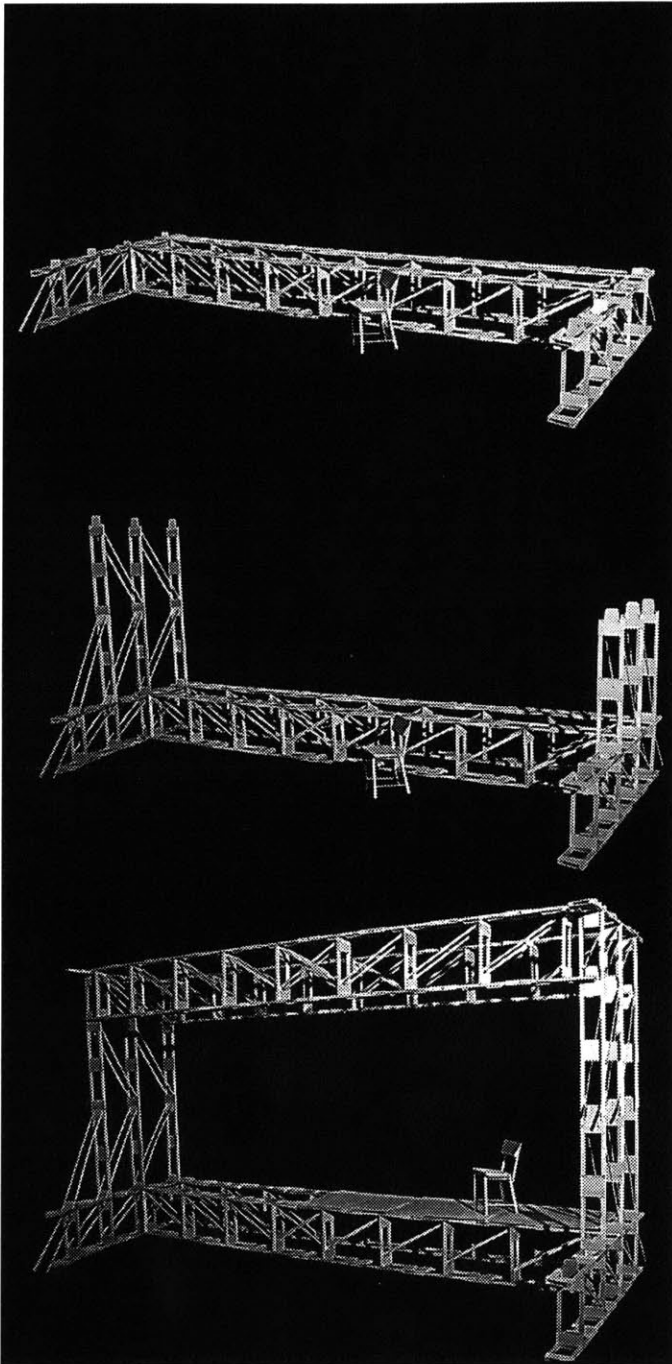

---

Once this beam is in place, the floor can now be assembled. The floor is comprised of numerous beams constructed out of A-units and Base-units as well. They are positioned so that the floor can be sheathed with 4x8 sheets. The depth of the beam not only allows the same units to be reused, but also provides sufficient depth for warm plumbing. The depth of the floor also allows for considerable free spans, eliminating the need for intermediary supports below the house.

The house is now ready for the courses of B-units. These units are identical to the A-units, except they are 48" in length, rather than 24". Two courses are used to attain the interior height desired. The courses switch direction to further resist racking and to increase rigidity.

A second course of A-units closed with Base-units is added. It is identical to the first. This closes the wall, creating a 12' deep perimeter beam, which not only supports the house, but acts as its walls at the same time. The result is an incredibly light and strong framework. The beams above that will support the roof are made precisely the same way as the floor beams, although there are fewer of them.

---

---

The beams support the conventional framing that will surround the clerestory windows. this framing will also support the end of the curved roof form.

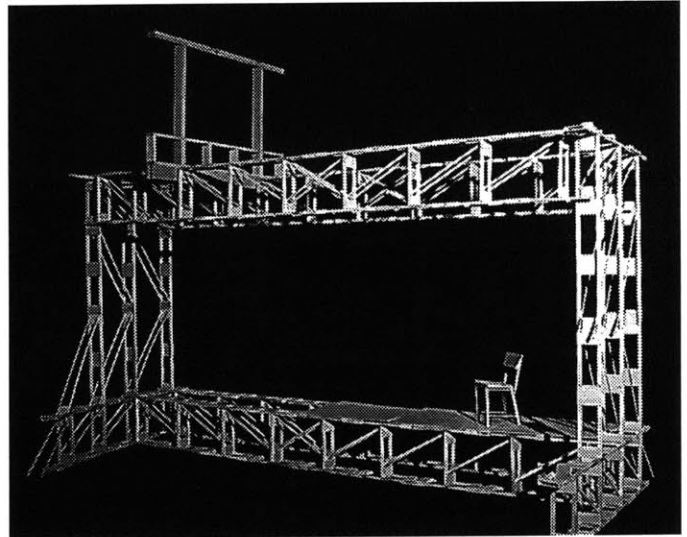

The crved roof form is made with a unique fourth unit. The Roof-unit is a hybrid of the Base-unit and the A-unit. With it, it is possible to make any curvature, including double curvatures.

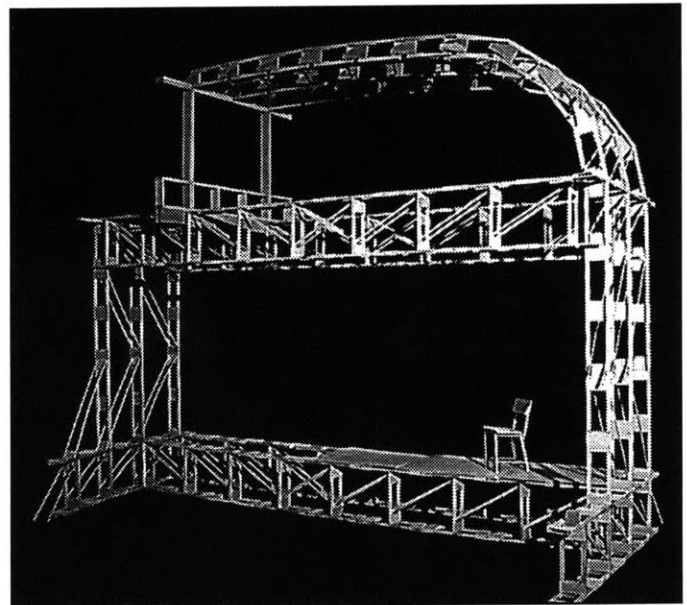



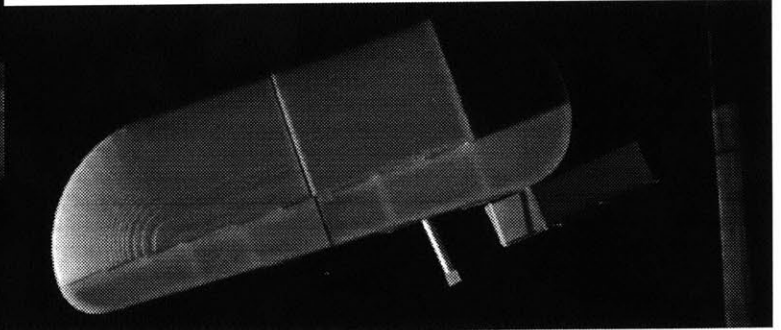
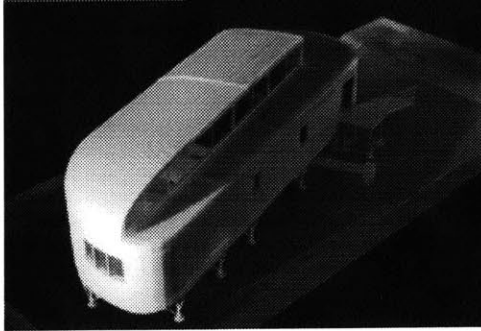
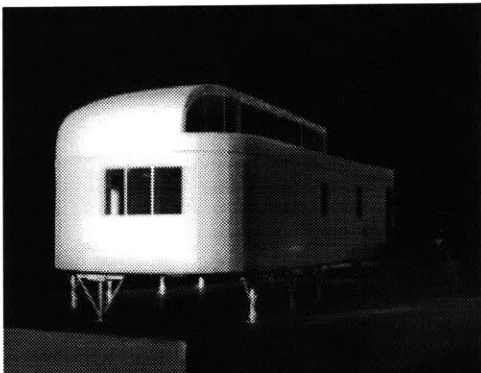

ARCTIC HOUSE

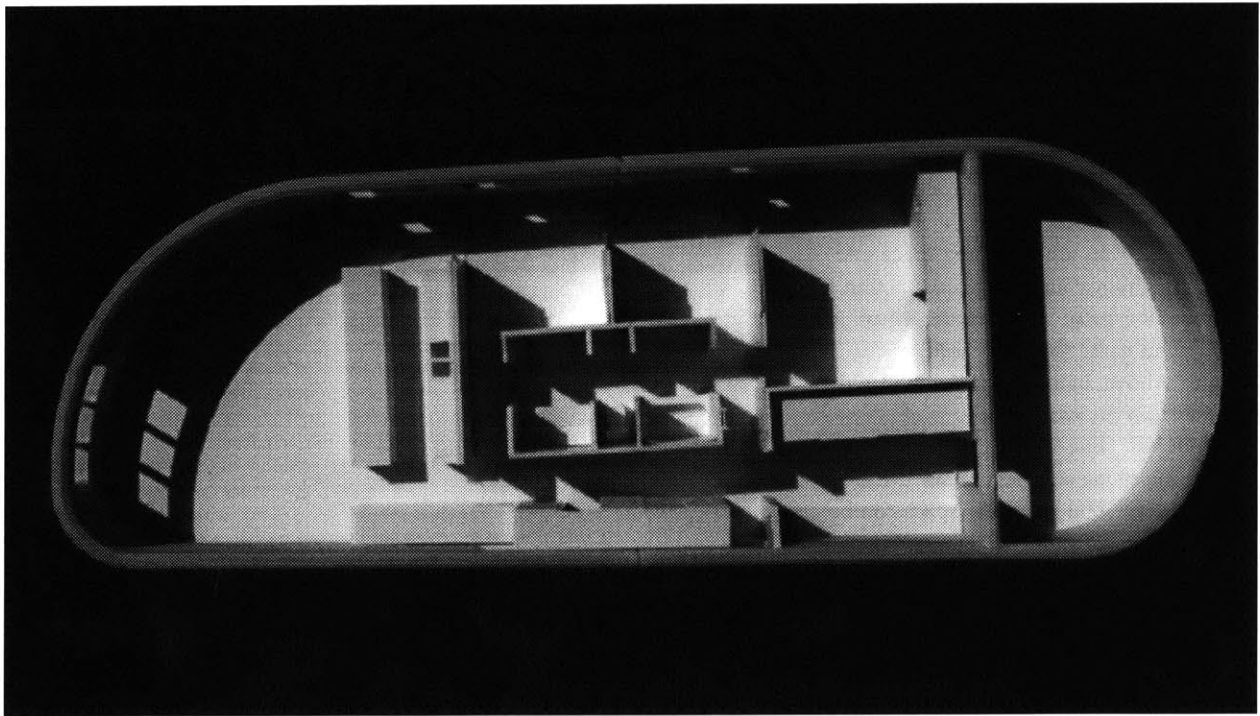
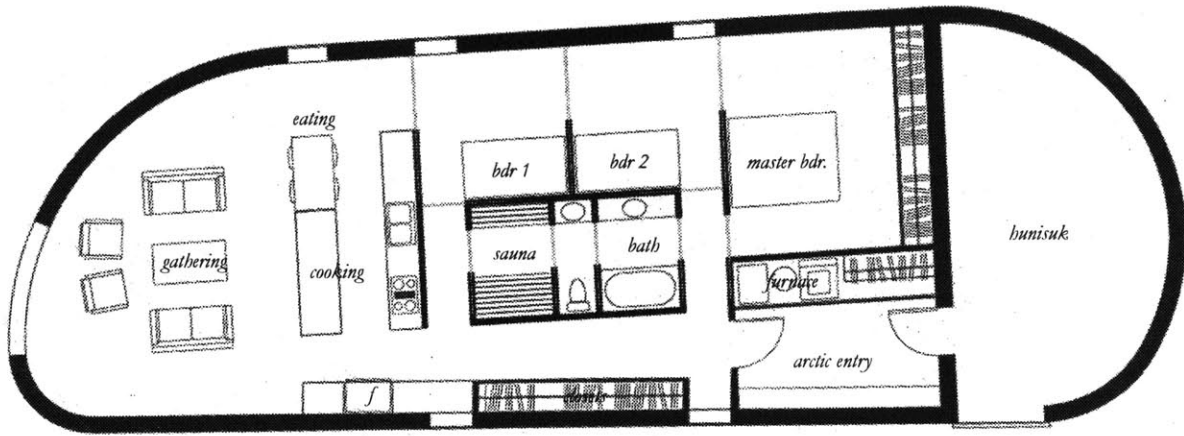

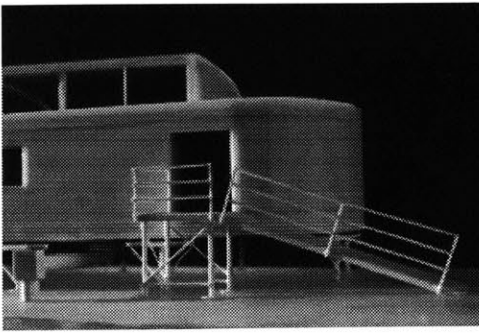

The Arctic House is raised on struts above the permafrost soil below. The *bunisuk* is accessed by a ramp and door large enough for moving game and machinery. The *bunisuk* is a space which is enclosed but unheated.

right: The arctic entry. An enclosed intermediary space between the inside and outside. From the entry, the gathering space at the nose of the house is visible down the corridor.

far right: From the gathering space one has easy physical and visual connection to the cooking area. The importance of eating and gathering is stressed by this space. Above, light reflects down into the house from the clerestory.

bottom left: The sleeping loft can be seen above the sauna and bath areas.

bottom left: The gathering space can be extended or partitioned by the moving panels between the rooms. When closed, the two rooms can serve as private bedrooms, and when open, they can become part of the larger living space.





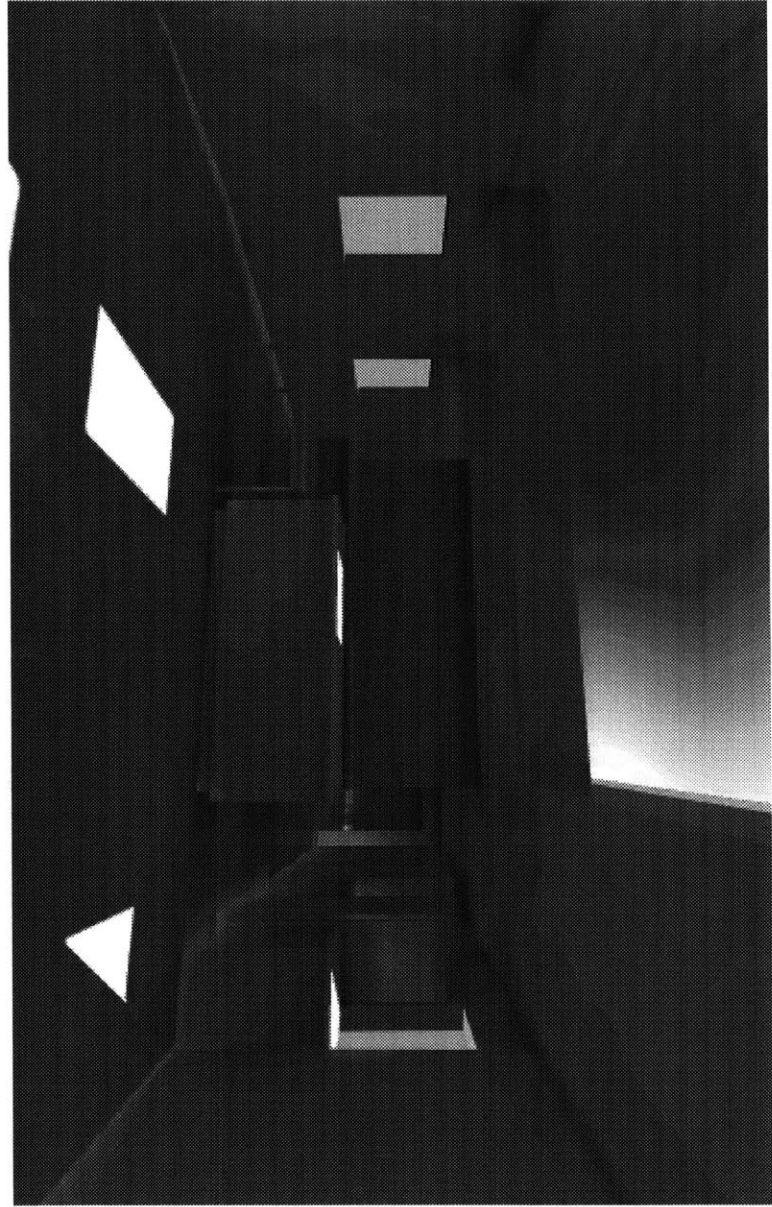

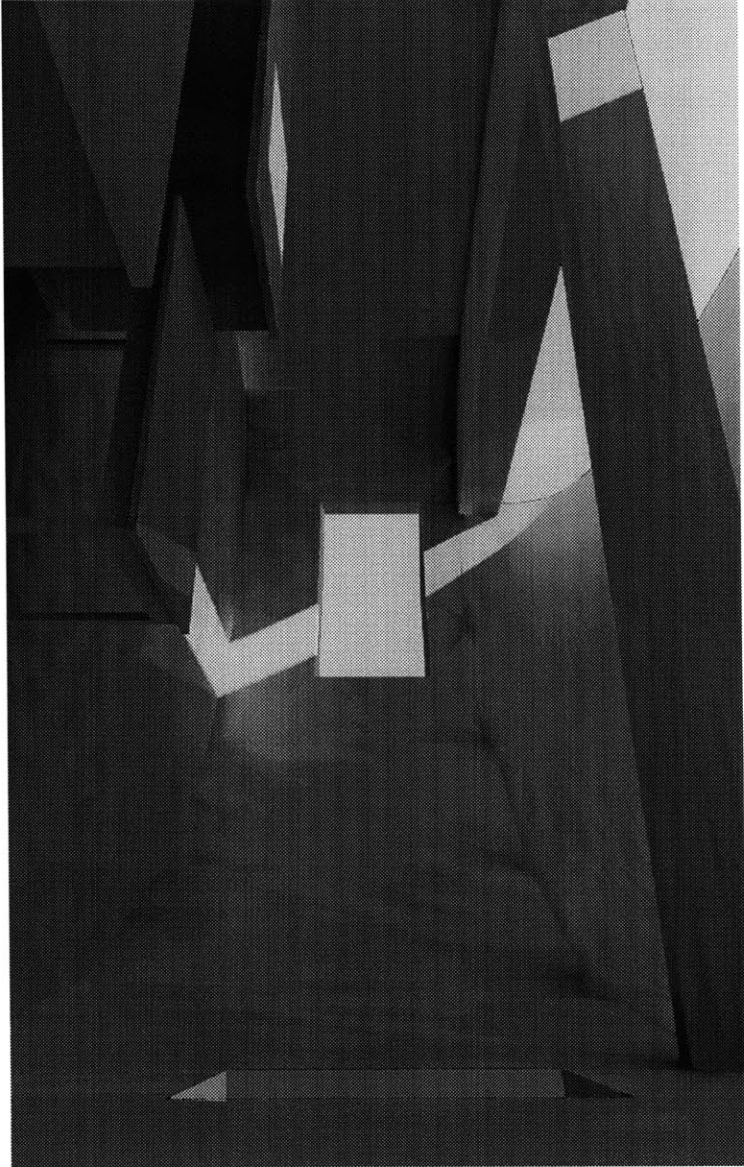
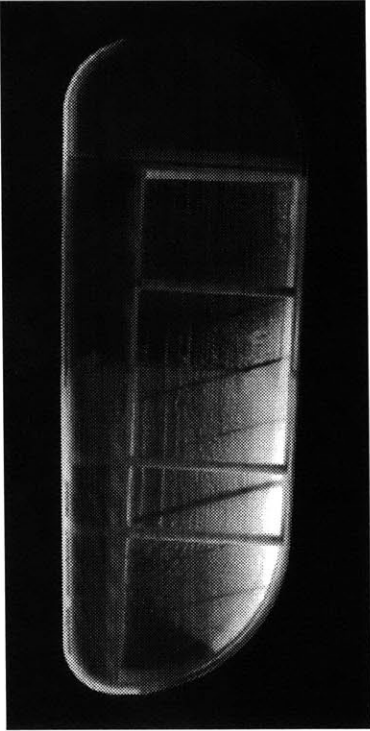

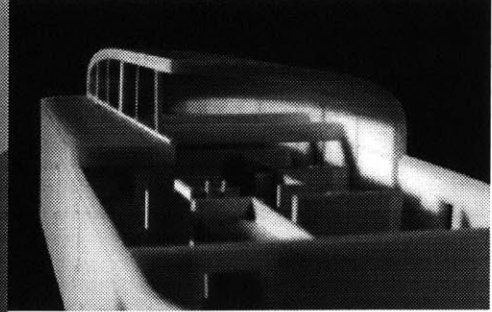
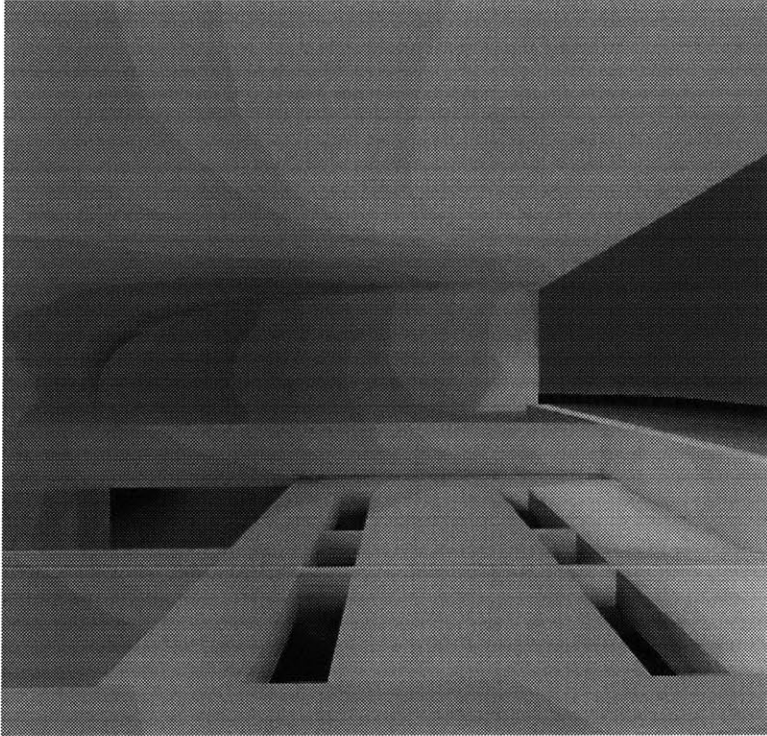

far left: The gathering space and eating area take advantage of the natural light from the clerestory. The light washes around the form of the room to illuminate it entirely.

lower left: A view of the entire ceiling of the Arctic House showing how the double curvature of the form allows light to enter.

above: The curved ceiling space created by the clerestory makes the sleeping loft above the sauna and bath areas. This space benefits from rising heat in the winter time, and also provides access to close insulated blinds during periods of extended dark.

The slots in the floor of the loft are filled with glass block and allow daylight to filter into the spaces below.

---

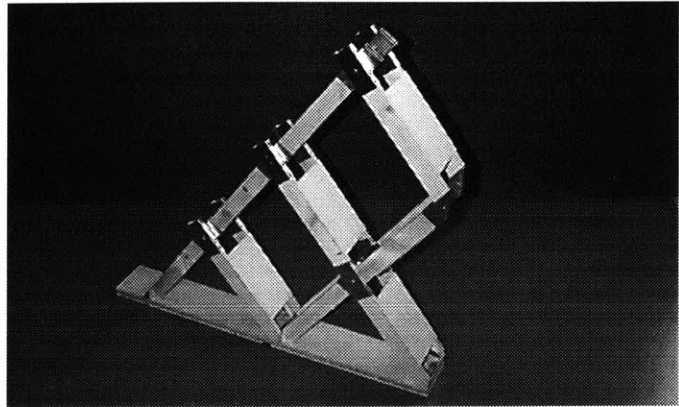

The Development of a Modular Bearing Wall System  
with Particular Reference to its  
Application in Cold Climates

Massachusetts Institute of Technology

Joel Turkel  
Fall 1997

Prepared for:  
4.455 - Special Problems in Building Construction  
Prof. Chris Luebke

---

---

---

---

## PREFACE

In May of 1993 I was living in central British Columbia in the small forestry town in which I had grown up called Williams Lake. I had returned from the University of Manitoba in Winnipeg, where I had just completed my bachelor's degree in Environmental Studies and Architecture. I had taken a full-time job with a civil engineering and land surveying firm, and for the first time in my life was intent on putting down some roots. It was this intention that led me to make a self-guided survey of the housing market in the area. A year of looking in earnest brought me to the conclusion that there were very few houses within the limited reach of my finances, and even fewer which were worthy of buying in any case. My schooling in the sub-arctic Winnipeg climate had left me with a sufficient understanding of proper building techniques for a cold climate that I found myself continuously dismayed at the poorly designed, and (what I felt to be) unjustifiably expensive houses around me. I was, at the time, sharing a single-wide mobile home with a high school friend who had just recently purchased it. After the second winter of frozen pipes and high gas bills, I was convinced I did not want to buy a mobile home for myself.

It became apparent to me at this time that if I were to get a home I really wanted, I was going to have to build it. If I was dismayed by the existing homes I had seen, I was even more dismayed by the expenses involved in a new home. It was about this time that I began to wonder where the middle ground was between mobile homes (which despite the efforts of their designers, had never quite shaken the stigma of the trailer park), and custom homes. I looked into premium mobiles and double-wides and modular homes, but when I was looking at them, I never quite lost the feeling that I was R.V. shopping. There was something entirely false to me about buying a home which already had pale green lace curtains installed in the bathroom. But the largest concern to me, was the one I was facing daily in my friend's mobile home, and that was the knowledge that his home was completely unsuited to the site it was on and the climate it was in.

At this point I began to wonder if there wasn't some way of designing a method of building which could begin to satisfy the needs for less expensive construction, the ability to be adequately insulated, and at the same time be sufficiently flexible to accommodate a large variety of floor-plans. It was in part the desire to make an attempt at such a design that led me to come to M.I.T. in the fall of 1996.

Over the course of the Fall semester of 1997, I began an investigation into this topic. I was unsure of where it would lead me, but I knew that whatever direction it took would provide me an understanding of some of the issues I deemed important. I began with an investigation of building systems, and the first thing that struck me about them was one of the same things which had troubled me about homes I had looked at in British Columbia, and that was the limited number of possible plans. I began to think of creating a small building block rather than a volumetric or panel system. In the early stages of my design development I had a conversation with Prof. Eric Dluhosch at M.I.T. He told me that if I were to do what I was proposing I needed "to create standardized parts and not standardized plans".

This became a very influential piece of advice for me, and over the course of the semester, became the aim of my design development. I set out to develop a modular system for building walls, rather than simply trying to build walls. The purpose of this paper is to describe the standardized parts I developed. I will begin with an outline of the design goals I set for myself and then enter immediately into a graphic description of the design.

---

---

## DESIGN OBJECTIVES

The following is a list of the objectives established that the design was required to follow. At each point in the design process, the developing system was evaluated based on these criteria.

The system must:

Be capable of easy assembly into load bearing walls.

Be comprised of small units which may be easily transported and moved on site by one person.

Be of as simple a design as possible, and lend themselves to a simple manufacturing process.

Be comprised of no more than three different unit types.

Use different unit types that are similar enough to one another that their use is sufficiently self-explanatory to the user.

Be capable of working within the framework of the existing 4x8 foot panel system of the North American building industry.

Represent a significant reduction in the amount of materials used in relation to comparable conventional building systems.

Provide a significant increase in amenity with relation to the insulation capacity of the wall.

Be capable of acting as a adjunct to existing wood frame construction.

Be capable of creating end abutments, intersections, and wall openings.

---



---

## SYSTEM DESCRIPTION

The System as it was developed consists entirely of two unit types: the A-unit and the End-unit. The A-unit is the primary unit in the System, and is comprised of three distinct parts. These three parts are the legs, the hinges, and the plate. The legs are the only part of the unit which is comprised of dimensioned lumber. There are four legs in each A-unit, each of a nominal section of 1"x3" by an actual length of 20". The legs are joined to each other by the hinges. There are two hinges in each of the A-units, and they are

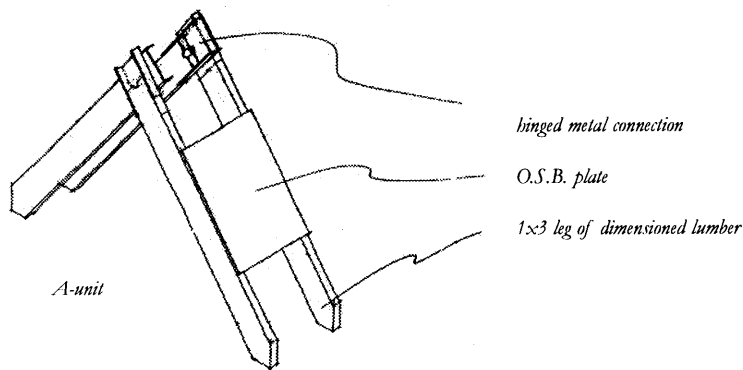

constructed of light gauge galvanized steel. Each hinge connects two of the legs to each other. The two pairs of legs are then joined together by the plate. The plate is simply a piece of plywood or structural fibreboard such as O.S.B. measuring 8" in length and 3/8" in thickness. The width of the plate can vary depending on the requirements of the individual situation, some of which will be described in the next section.

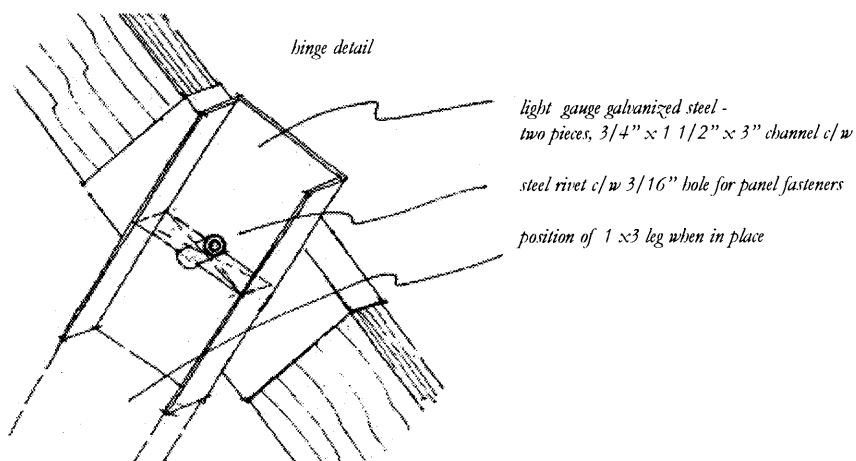

---

The A-units can be assembled together like blocks by virtue of the manner in which the hinge creates a place for the foot of the next A-unit to sit. The units can be added in this fashion until the desired height is attained. It can here be seen that the end of the wall is now angled.

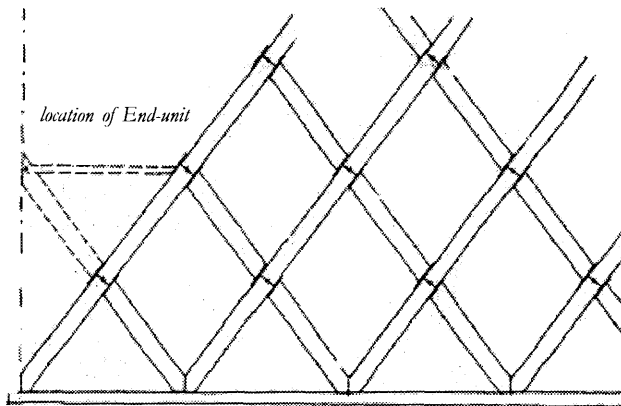

The resolution of the angle into a perpendicular end abutment is made possible by the introduction of the End-unit. The End-unit is also comprised of three distinct parts. Two of these three are identical to those used in the A-unit. Unlike the A-unit, the End-unit is comprised of only two legs instead of four. The two legs of the End-unit are joined by the same plate that is utilized by the A-unit.

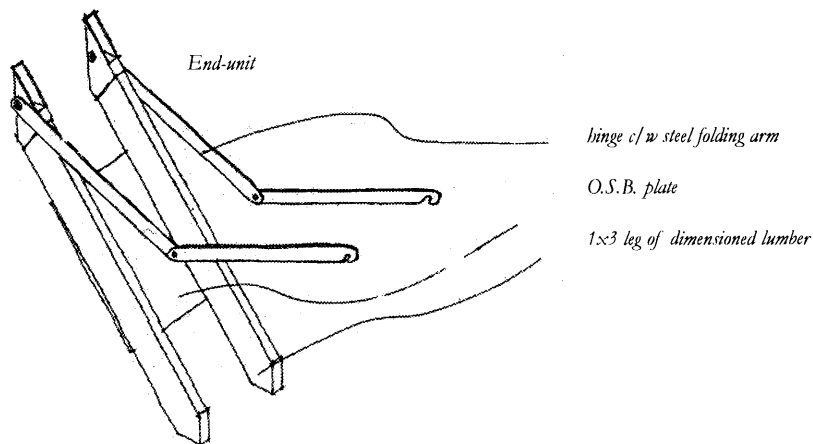

---

The primary difference between the two units is in the hinge. The construction of the hinge is here again light-gauge galvanized steel. The hinge sits on the end of the legs of the unit. On one side of each hinge there is a small folding arm of steel specially designed such that one end will engage the corresponding point in the opposite A-unit hinge. When the End-unit is in place, the arm unfolds and locks into place. The arm of the End-unit provides resistance for the horizontal thrust developed by the addition of the next A-unit which is placed above it.

*End-unit hinge detail*

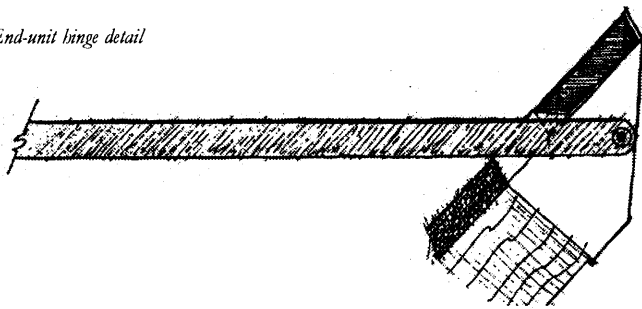

*End-unit hinge locked into opposite A-unit*

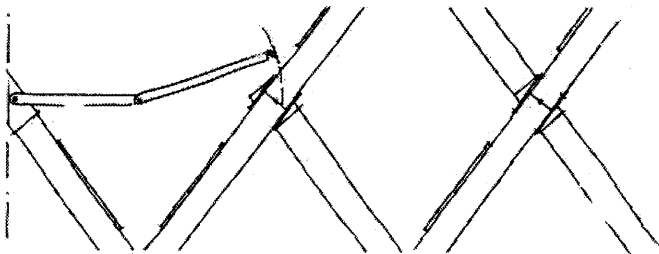

*End unit in place with addition of next A-unit above*

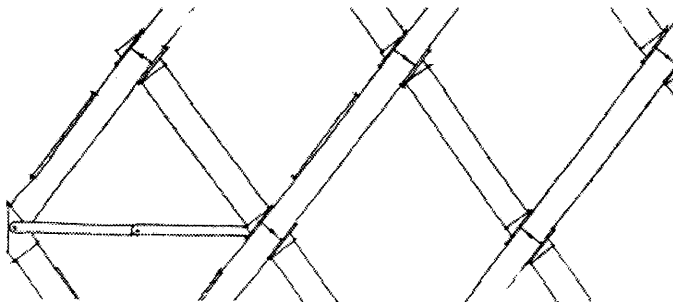

---

As can be seen in the previous illustrations, the hinge on the End-unit is designed with a surface perpendicular to the floor plane the wall is constructed on. This surface is created so that sheathing or dimensioned lumber may be affixed to complete the end of the System wall. This dimensioned lumber becomes necessary when using two System walls to make a corner, or when a perpendicular wall is required in the middle of a straight wall for shear resistance.

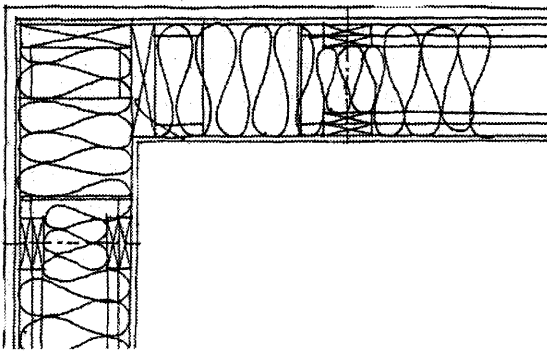

*System wall corner detail:*

- finish siding on
- exterior sheathing on
- Tyvek air barrier on
- system wall units c/w
- granular insulation on
- vapor barrier on
- interior finish

As described in the section on Design Goals, the System wall was designed to be capable of functioning within the existing 4x8 foot standard in the North American building industry. This goal is addressed by the size of the units. The units are designed to respect centerline measurements of 16" x 24". These measurements ensure that the 4x8 panel is met with a series of points it can be affixed at that correspond with center points of the unit hinges. As was illustrated earlier, each hinge in both the a-units and the End-units are designed with small openings in the center of their rivets to allow for the insertion of sheathing or drywall fasteners. These openings are intended to allow special fasteners to be used in the corresponding pre-drilled holes in all 4x8 panels.

---

---

## SYSTEM ANALYSIS

The system as designed has numerous potentially beneficial features as well as some aspects that will require further development. Many of the aspects were intentionally designed for as expressed earlier and others arose out of the design process.

The first of these concerns the amount of dimensioned lumber used by the System wall. The apparent pros and cons to the System will be made more easily understood by a comparison of two walls, a conventional 2x6 stud wall measuring 12 feet in length by 8 feet in height, and the corresponding System wall of the same dimension .

The comparisons will be made based on the number of cubic inches of material used. All nominal dimensions relating to lumber will be converted to actual sizes for the sake of accuracy.

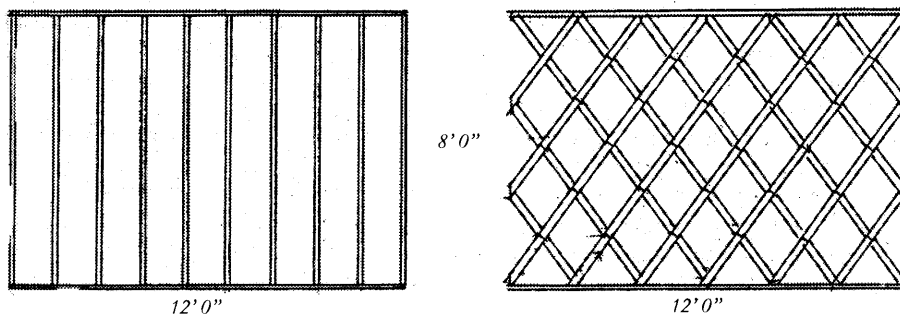

*A conventional 2x6 stud wall and the System wall*

### Conventional 2x6 Stud Wall - 12' x 8'

10 - 2x6 studs, 96" in length @ 16" o.c. =  $10(1.5'' \times 5.5'' \times 96'') = 7,920$  cubic inches

### System Wall - 12' x 8'

33 A-units + 6 End-units

A-unit (each) = 4 - 1x3 pieces, 20" in length =  $4(0.75'' \times 2.5'' \times 20'') = 150$  cubic inches

+ 1 plate O.S.B. -  $5.5'' \times 8'' \times 3/8'' = 16.5$  cubic inches.

Total per unit = 166.5 cubic inches

End-unit (each) = 2 - 1x3 pieces, 20" in length =  $2(0.75'' \times 2.5'' \times 20'') = 75$  cubic inches

+ 1 plate O.S.B. -  $5.5'' \times 8'' \times 3/8'' = 16.5$  cubic inches

Total per unit = 91.5 cubic inches

33 A-units @ 166.5 cu. in. + 6 End-units @ 91.5 cu. in. = **6,043 cubic inches**

---

---

If these two figures are then compared, it can be seen that the System wall represents a material saving of almost 24%, including all wood fibers in both walls. Since both walls would require both top plates and a bottom plate in their construction, the figures for those members have been omitted in the calculations.

As a result of the modular characteristics of the System, there is no piece in either the A-unit or the End-unit which is of more than 20 inches in length. This, when coupled with the fact that the largest dimension is nominally only 1x3 inches, could be viewed favorably when considering the number of sources for material needed for the manufacture of these units. The scarcity of older growth forests, and hence, the expense of dimensioned lumber, make the prospect of creating a system less dependant on them increasingly important.

One problem which has long been of issue with conventional construction, is that of attaining higher R-values within a given wall section. Although this paper is not intended to provide a detailed description of them, some examples must be made for the purpose of comparison. Several methods have been attempted in cold regions, which often resulted in quickly diminishing returns in terms of dollars expended per R-value return.

One such example is the double stud wall which consists of two standard stud walls tied together by plywood top and bottom plates. The total width of the wall is determined by the width of these plates. R-values can be increased in this fashion, often as high as R40, although the expense is greatly increased due to the fact that there are essentially two walls being constructed.

Another wall section which is commonly used to increase R-values, is obtained by affixing additional rigid insulation to the exterior of a 2x6 wall. This method can increase R-values to R27. This wall is more cost-effective in that it does not require the addition of more wood frame construction. The use of this section however, limits the builder in choice of finishing materials which can be affixed to rigid insulation. The high cost of extruded polystyrene and the problems associated with its proper installation are also to be considered.

In the first example, a single 2x4 stud wall with a maximum R-value of 12 (using fibreglass batt) was doubled. If the two stud walls were to be spaced such that the wall had an R-value of 30, the thickness of the wall would be 9.5 inches, assuming fibreglass insulation at 3.17R/inch. If one were to examine a 12 foot length of the wall constructed out of 2x4s at 24" centers, the amount of wood used would be as follows:

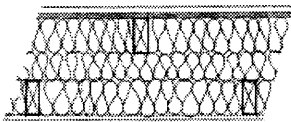

*A double stud wall*



*A conventional 2x6 stud wall*

Conventional Single 2x4 Stud Wall – 12' x 8' (R12)

7 – 2x4 studs, 96" in length @ 24" o.c. =  $7(1.5" \times 3.5" \times 96") = 3,528$  cubic inches

Conventional Double 2x4 Stud Wall – 12' x 8' (R24+)

14 – 2x4 studs, 96" in length @ 24" o.c. =  $14(1.5" \times 3.5" \times 96") = 7,056$  cubic inches

It can hereby be seen that a wood increase of 100%, or 3,528 cubic inches is required to make a gain of R18, as in this case, although the walls could be positioned such that the gain could be from R12-R28.

---

---

For the sake of this comparison, a single System wall of only R12 would also be four inches in nominal depth (using poured loose fibreglass insulation @ R3.03/inch).<sup>3</sup> To make the same increase to R30 would require increasing the wall depth to 10 inches, a difference of half an inch as a result of the difference in insulations required by each wall.

In order to make the adjustment to R30, the System wall needs adjust by varying the size, or moreover, the width of the O.S.B. plates utilized in each A-unit and End-unit of the wall. This is merely requires the substitution of wider plates in the units at the time of manufacture. It is possible that a series of sizes could be standardized to coincide with the R-values required in the regions in which they would be used.

Below are calculations showing the increased amount of wood required as the System wall is transformed from an R12 wall to an R30 wall.

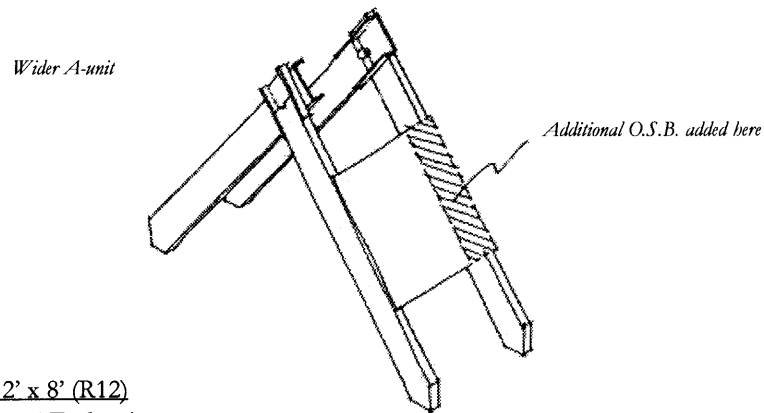

System Wall - 12' x 8' (R12)

33 A-units + 6 End-units

A-unit (each) = 4 -1x3 pieces, 20" in length =  $4(0.75" \times 2.5" \times 20") = 150$  cubic inches  
 + 1 plate O.S.B. -  $4" \times 8" \times 3/8" = 12$  cubic inches  
 Total per unit = 162 cubic inches

End-unit (each) = 2 -1x3 pieces, 20" in length =  $2(0.75" \times 2.5" \times 20") = 75$  cubic inches  
 + 1 plate O.S.B. -  $4" \times 8" \times 3/8" = 12$  cubic inches  
 Total per unit = 75 cubic inches

33 A-units @ 162 cubic inches + 6 End-units @ 75 cubic inches = **5,796 cubic inches**

System Wall - 12' x 8' (R30)

33 A-units + 6 End-units

A-unit (each) = 4 -1x3 pieces, 20" in length =  $4(0.75" \times 2.5" \times 20") = 150$  cubic inches  
 + 1 plate O.S.B. -  $10" \times 8" \times 3/8" = 30$  cubic inches  
 Total per unit = 180 cubic inches

End-unit (each) = 2 -1x3 pieces, 20" in length =  $2(0.75" \times 2.5" \times 20") = 75$  cubic inches  
 + 1 plate O.S.B. -  $10" \times 8" \times 3/8" = 30$  cubic inches  
 Total per unit = 105 cubic inches

33 A-units @ 180 cubic inches + 6 End-units @ 105 cubic inches = **6,570 cubic inches**

---

---

The wood increase therefore is 774 cubic inches, or 13.4%, to make the same gain of R18. This discrepancy between the two systems is clearly the result of the manner by which the two halves of the A-Units are joined. The use of the O.S.B. plate to perform this function provides a clear benefit to the System wall when possible R-values are considered. It is clear from these figures that the majority of wood material used in the construction of the System wall is kept near its surfaces – i.e. – on either the warm or cold side of the building envelope and not in the center of the section. This is indicative of the fact that very little material is actually continuous from one side to the other. It is this separation of material which provides the System wall with a distinct advantage over the conventional wall in terms of thermal bridging. A comparison can then be made to quantify the actual amount of material in each wall which may act as a thermal bridge.

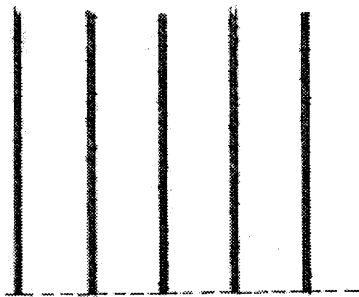

*thermal bridging in 2x6 wall*

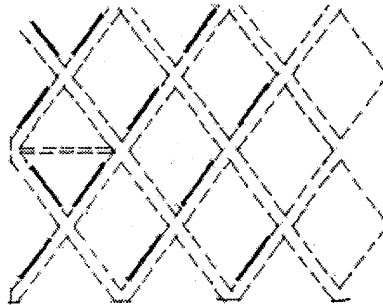

*thermal bridging in System wall*

Conventional 2x6 Stud Wall - 12' x 8'

10 - 2x6 studs, 96" in length @ 16" o.c. =  $10(1.5" \times 96") = 1,440$  square inches

System Wall – 12' x 8'

33 A-units + 6 End-units

A-unit (each) = 1 plate O.S.B. –  $8" \times 3/8" = 3$  square inches

End-unit (each) = 1 plate O.S.B. –  $8" \times 3/8" = 3$  square inches

$33(3 \text{ in. sq.}) + 6(3 \text{ in. sq.}) = 117$  square inches

It can be seen from these figures that the System wall represents a potential decrease in the level of thermal bridging across the insulated substrate of more than 91%. One benefit in the construction of the conventional wall, is the amount of surface area the studs provide for affixing exterior sheathing and interior finished surfaces. The conventional wall of 2x construction with 16" centers provides nailing surface as follows:

---



---

Conventional 2x Stud Wall - 12' x 8' (nailing surface)

10 - 2x6 studs, 96" in length @ 16" o.c. =  $10(1.5'' \times 96'') = 1440$  square inches

System Wall - 12' x 8' (nailing surface)

33 A-units + 3 End-units

36 - 1x3 pieces, 20" in length =  $36(2.5'' \times 20'') = 1800$  square inches

The System wall represents an increase of 25% in the amount of nailing surface. This increase in nailing surface also represents an increase in potential surface friction between the System wall and its sheathing. One of the benefits of the conventional system, is that the nailing surface is perpendicular to the strong axis of each stud. The System wall uses a nailing surface which is parallel to the strong axis of each 1x3 member. This would no doubt be problematic if it were not for the fact that the strong axis of the O.S.B. plate serves as a connection between the interior and exterior nailing surface of each A-unit and End-unit. It is the difference in the geometries of the two systems that causes the difference in the orientation of the nailing surfaces. It is this geometry that gives the System wall its inherent rigidity. Because it is in essence comprised of a series of interlocking triangles, the System wall attains rigidity along its strong axis superior to that attained by the conventional wall before it is sheathed. If the System wall were capable of attaining sufficient lateral stability in this fashion, it would be possible to use non-structural fibreboards or other non-structural sheathings.

As was illustrated earlier, the units are both designed with a hinge and the main reason for this is so that they may be flat-packed. By flat-packing the units, the System wall may be more easily transported. The units may be interlocked when flat-packed to conserve more volume

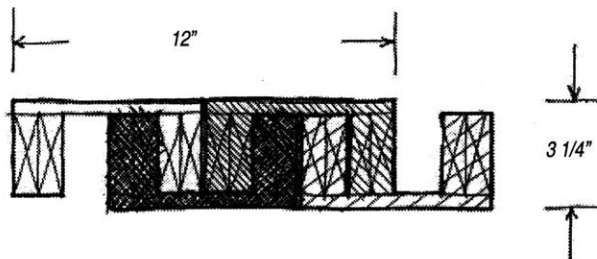

*section of interlocked and flat-packed units*

Conventional 2x6 Stud Wall - 12' x 8' (material volume)

10 - 2x6 studs, 96" in length. =  $10(1.5'' \times 5.5'' \times 96'') = 7,920$  cubic inches

System Wall - 12' x 8' (material volume when flat-packed)

33 A-units + 6 End-units @ 4 units/linear foot

one linear foot of units when flat packed =  $12'' \times 3.25'' \times 20'' = 780$  cubic inches/ linear foot 39units

@4/linear foot =  $9.75' @ 780$  cu. in./linear foot = **7,605 cubic inches**

---

---

MODEL PHOTOGRAPHS

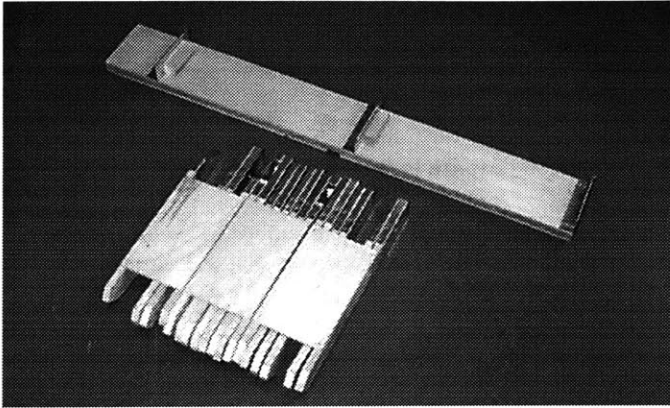

*The System wall in its collapsed state showing A-units and End units flat packed.*

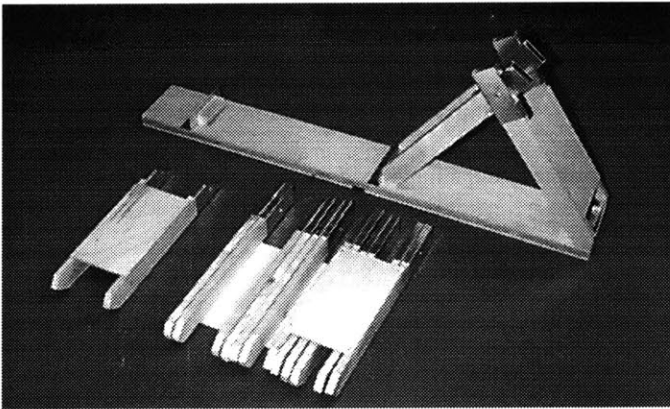

*The System wall showing one A-unit in position on its base plate.*

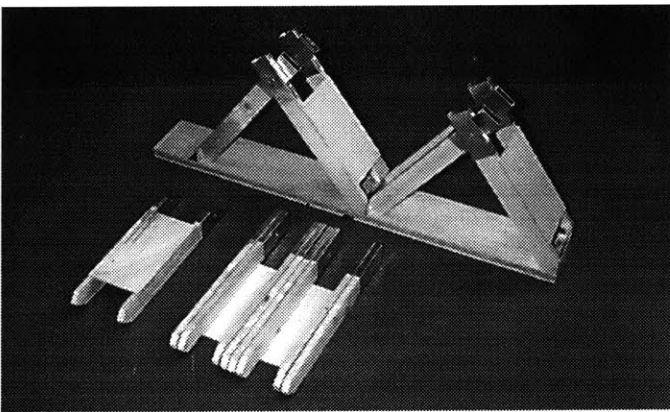

*The System wall showing three A-units in position on base plate. The two units form the position for a third that will begin a second course*

---

---

*The System wall showing three A-units in position on the base plate. The wall is now ready to use an End unit to create a perpendicular end surface.*

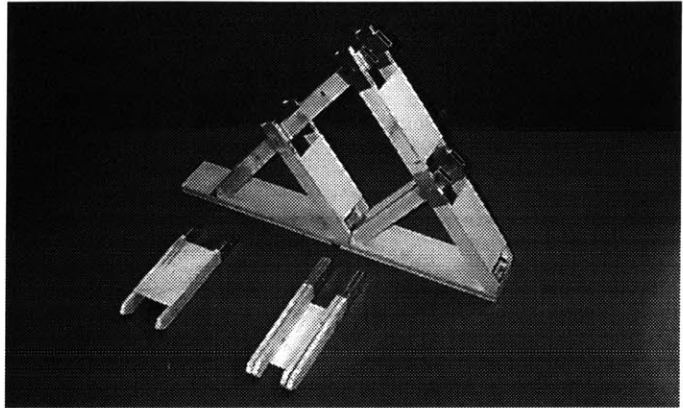

*The System wall showing three A-units with an End-unit in place. The wall is ready for a third course.*

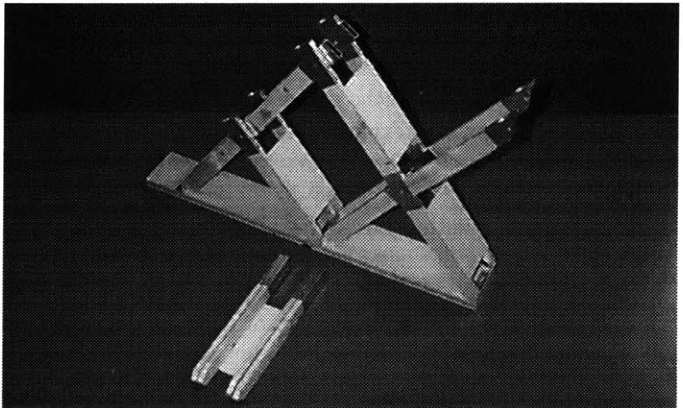

*The System wall illustrating its potential for creating a continuous load-bearing modular wall system.*

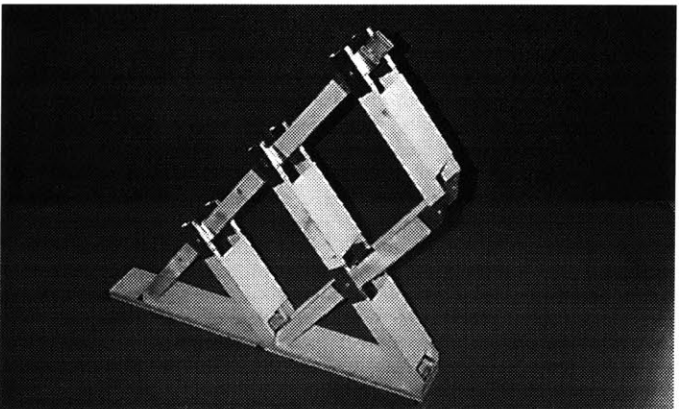

---

## BIBLIOGRAPHY

- Adamson, Bo. et al., Design of Low Energy Houses with Lightweight Wall and Roofs in Severely Cold Climates. Stockholm: Swedish Council for Building Research, 1987.
- Argue, Robert., The Well-Tempered House – Energy-Efficient Building for Cold Climates. Toronto: Renewable Energy in Canada, 1980.
- Blach, Klaus., “Research Designed Low-Energy House: Based on Modular 410 mm-wide Cavity Brickwork”, in Building Research and Practice, 1984, July-Aug, v.12, n.4.
- Canada Mortgage and Housing Corporation., Energy Efficient Housing Construction. Ottawa: CMHC, 1985.
- Canada Mortgage and Housing Corporation., Energy Conservation in New Small Residential Buildings. Ottawa: CMHC, 1984
- Canada Mortgage and Housing Corporation., The Conservation of Energy in Housing. Ottawa: CMHC, 1986.
- Gutdeutsch, Gotz., Building in Wood, Boston: Birkhauser Verlag, 1996.
- Larsson, Nils K., Energy Consideration in the design of Northern Housing. Ottawa: National Research Council of Canada, 1985.
- Matus, Vladimir., Design for Northern Climates. New York: Van Nostrand Reinhold Company, 1988.
- Prieto-Portar, Luis A., “An Advance in 3-Dimensional Modular Housing”, in International Journal for Housing Science and its Applications, 1994, v. 18, n.4.
- Reidelbach, John A., Modular Housing. Annandale, VA: Modco, 1972.
- Reidelbach, John A., Modular Housing in the Real: a Study of the Industry and the Product, Boston: Cahners Books, 1970.
- Wilson, Alex., “Insulated Panel Construction: Modular Units Offer Resource and Energy Efficient Alternatives to Wood Framing”, in Architecture, 1991, Oct., v.80, n.10.
- Wolfman, Ira., “Modular construction Comes of Age”, in Architectural Record, 1988, Dec., v.176, n.14.
- All photographs and illustrations by the author
-

---

## BIBLIOGRAPHY

---

*Alaska Housing Manual*. Anchorage: Alaska Housing Finance Corporation, 1998.

*Alaska Market for Value Added Lumber Products*. Anchorage: Alaska Science and Technology Foundation, 1998.

'Arctic town gets royal flush; \$349-million sewerage system is Barrow's first'. *Engineering News-Record*, January 5, 1984.

Brewster, Daniel. Osbourne Construction Co. Personal Interview, August 23, 1998.

Dunets, A. and Smith, D.W. 'The House in Cold Climates – Current Technologies'. *Cold Regions Engineering*. New York: American Society of Civil Engineers. 1988.

Hendrickson, Terry. Bowhead Transportation Co. Personal Interview, August 24, 1998.

Ferrians, Oscar J., and Kachadoorian, Rueben. *Permafrost and Related Engineering problems in Alaska*. U.S.G.S. Professional Paper #678. Washington, D.C.: U.S. Govt. Printing Office, 1969.

Flanders, Stephen N. and Tobiasson, Wayne N., P.E. 'Designing with Wood for a Lightweight Air-Transportable Arctic Shelter: How the Materials were Tested and Chosen for Design'. *Structural Use of Wood in Adverse Environments*. New York: Van Nostrand Reinhold Co. 1987.

Glover, Michael, ed. 'Building in Northern Communities'. *Man in the North Technical Paper*. Montreal: Arctic Institute of North America, 1974.

McFadden, Terry T. and Bennet, F. Lawrence. *Construction in Cold Regions*. New York: John Wiley and Sons, Inc., 1991.

Muller, S.W., *Permafrost or Perennially Frozen Ground and Related Engineering Problems*. Ann Arbor, MI: Edwards Bros., 1947.

*Major Ecosystems of Alaska*. Anchorage: Joint Federal-State Land Use Planning Commission for Alaska, (1973).

Peterson, Casey. North Slope Borough Housing Office. Personal Interview, August 22, 1998.

Rabb, Judith. *Good Shelter: A Guide to Mobile, Modular, and Prefabricated Houses*. New York: Quadrangle/New York Times Book Co., 1975.

'Top of the World'. *Forbes*. 132(10). Oct 24, 1983.

All photographs by the author unless otherwise noted

---

---



---