

Collective Space for M.I.T. West Campus

By Donna Anne Barbaro

B.A. Washington University, 1977

Submitted in Partial Fulfillment of the Requirements for the Degree
of Master of Architecture at the Massachusetts Institute of Technology
June 1981

© Donna Anne Barbaro 1981

The Author hereby grants to M.I.T. permission to reproduce and to
distribute copies of this thesis document in whole or in part.

Signature of the Author.....
Department of Architecture. May 8, 1981

Certified by.....
Barry Zevin, Assistant Professor of Architecture
Thesis Supervisor

Accepted by.....
Sandra Howell, Chairperson
Departmental Committee for Graduate Students

ROTC
MASSACHUSETTS INSTITUTE
OF TECHNOLOGY

MAY 28 1981



Room 14-0551
77 Massachusetts Avenue
Cambridge, MA 02139
Ph: 617.253.2800
Email: docs@mit.edu
<http://libraries.mit.edu/docs>

DISCLAIMER OF QUALITY

Due to the condition of the original material, there are unavoidable flaws in this reproduction. We have made every effort possible to provide you with the best copy available. If you are dissatisfied with this product and find it unusable, please contact Document Services as soon as possible.

Thank you.

The images contained in this document are of the best quality available.

ABSTRACT

COLLECTIVE SPACE FOR MIT WEST CAMPUS

By Donna Anne Barbaro

Submitted to the Department of Architecture on May 15, 1981 in partial fulfillment of the requirements for the degree of Master of Architecture.

The vitality felt in proceeding through a marketplace or in walking through the streets of some towns and cities can sensitize one to the particular potential a street can have as a place for informal conversation, sitting, watching or gathering collectively - an alternative setting to the social atmosphere that exists within offices or classrooms. The range of outdoor spaces that can be found are organized according to principles which people have agreed upon formally or informally over time. Streets with this level of definition are easy to stay in, move ones' chair or wares out into or carry on 'with business' in. Although passage through is often its most important function, a successful street also offers a clarity of territorial definition with 'eddies,' boundaries and backs that allow a range of other activities to occur.

In its best sense, one could feel that one is moving through a collection of outdoor rooms of various enclosure, each related in some sense to both the public path and to the less public spaces beyond.

On a university campus, where exposure and discourse are encouraged, a collective backbone of this nature would be an asset, both as an outlet within the university and as a way of tying the university to the surrounding community.

The intention of this thesis is two-fold; first to explore street as place and "linkage" in the context of site and building edge; and second, to suggest alternatives for the MIT West Campus.

Thesis Supervisor: Barry Zevin
Title: Assistant Professor of Architecture

To all those who helped me keep things in perspective.

Table of Contents

ABSTRACT.....	3
ACKNOWLEDGEMENTS.....	5
INTRODUCTION.....	9
Existing West Campus.....	10
Study Site.....	12
Program.....	13
DESIGN PROCESS.....	14
Initial Site Studies.....	16
Studies for the Student Center..	30
Building Components.....	34
SCHEMATIC DESIGN PROPOSAL.....	44
ASPECTS OF THE STREET; PATTERNS....	57
BIBLIOGRAPHY.....	79

Introduction

The M.I.T. campus is organized primarily in the east-west direction along double loaded corridors. With few exceptions, there are no opportunities for a person to reference vertically or horizontally in space. The Charles River, a major referential resource running parallel to the corridor system, is not utilized sufficiently as an orientation device from

within. Unless you're in Lobby Ten and able to see the Great Court and river, it is very easy to become disoriented in your travels through the corridor network. Vertical referencing presents similar problems. There are few visible vertical continuities along the corridors that make clear what's above and below you. Again, the lobbies of buildings provide vertical relationships

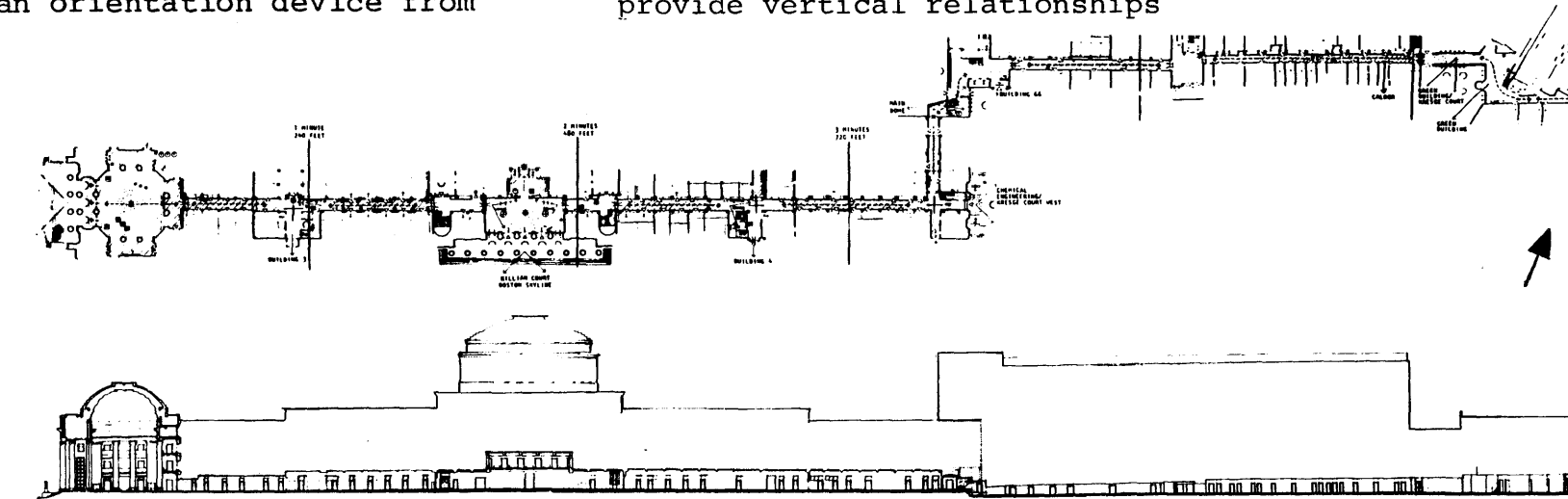

1 Main corridor through east campus in plan and section.

among floors but cases such as these are rare. In most instances, movement through the hallways as they relate to the whole building complex is not spatially clear. One is either in or outside.

Not only is the 'volumetric space' inadequate in orienting people as they move through, but so are the 'spatial edges', or wall zones along the corridors. The walls rarely become territorial; usable for sitting in, putting displays in, or for delineating an entrance.

EXISTING WEST CAMPUS

The path through West Campus is less disassociative but this has more to do with the fact that so much of it is unbuilt rather than the result of a conscious effort to maintain a three-dimensional order. Few

internal activities address the 'street' at ground level. Both the internal functions and the entrance to the existing Stratton Student Center provide no overlap with the street edge, causing it to be a completely internalized environment. Kresge and the Chapel, both inwardly focusing buildings, are difficult to move up against. They provide no buffer of street oriented edge to back up to.

Buildings such as McCormick Dormitory along Memorial Drive, in their east-west orientation, cut off views to the Charles River.

Along Vassar Street to the north, buildings such as West Garage and the Metropolitan Warehouse act as a wall, impeding growth and view beyond.



2

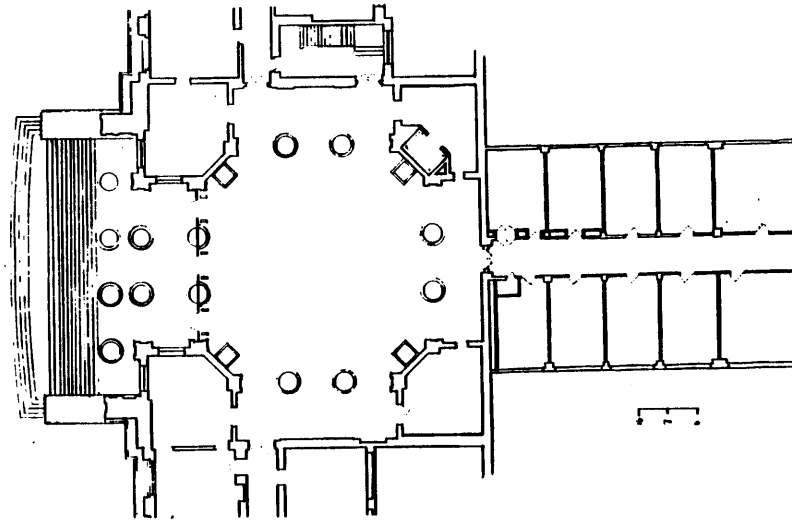

3

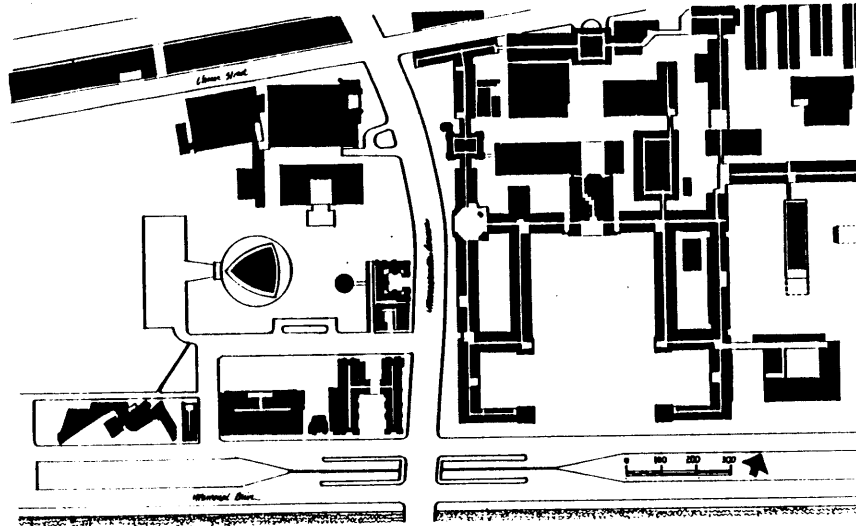

4

STUDY SITE

For the purpose of this exploration several West Campus buildings have been removed. Those that remain are Ashdown, Bexley, Cavs, Dupont, the Rockwell Cage and Baker House, with the Chapel and Kresge to be considered in later schemes.

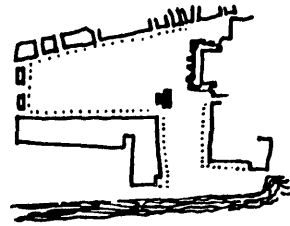

5

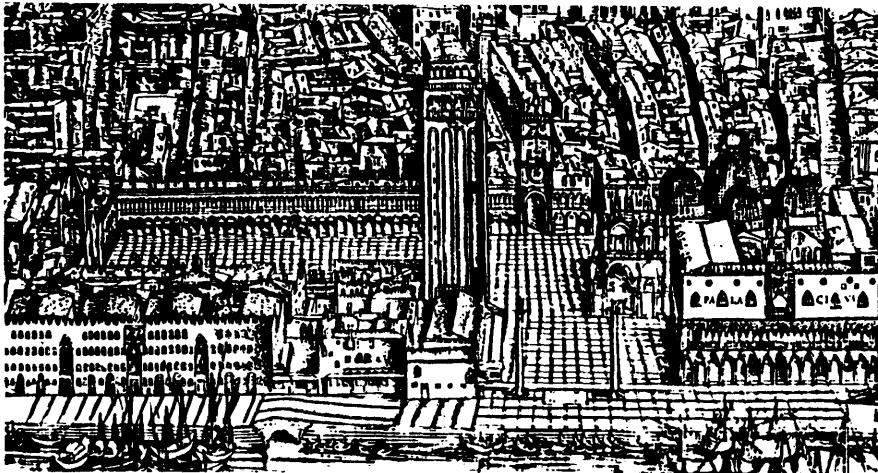

6

The Charles River and the Athletic Field provide the primary spatial references for the West campus with the Rogers Building and Massachusetts Avenue playing a lesser role. At all times in moving through West campus one should be able associate with at least one of these, either directly or through an indirect reference. At the heart of Piazza San Marco in Venice, for instance, although you may not be able to see the water, in knowing the clear relationship of the

tower to the water you can immediately understand your whereabouts.

Pedestrian movement through the site flows primarily toward the dormitories along Memorial Drive with fewer people moving toward West Garage and other activities along Vassar Street.

PROGRAM

The design proposal accommodates those uses which have been removed for the purpose of the exploration. These include primarily the activities of the present student center, along with dormitories, medical services, a gymnasium and services for the existing gymnasiums. Along with this, additional shops and dormitories are provided for.

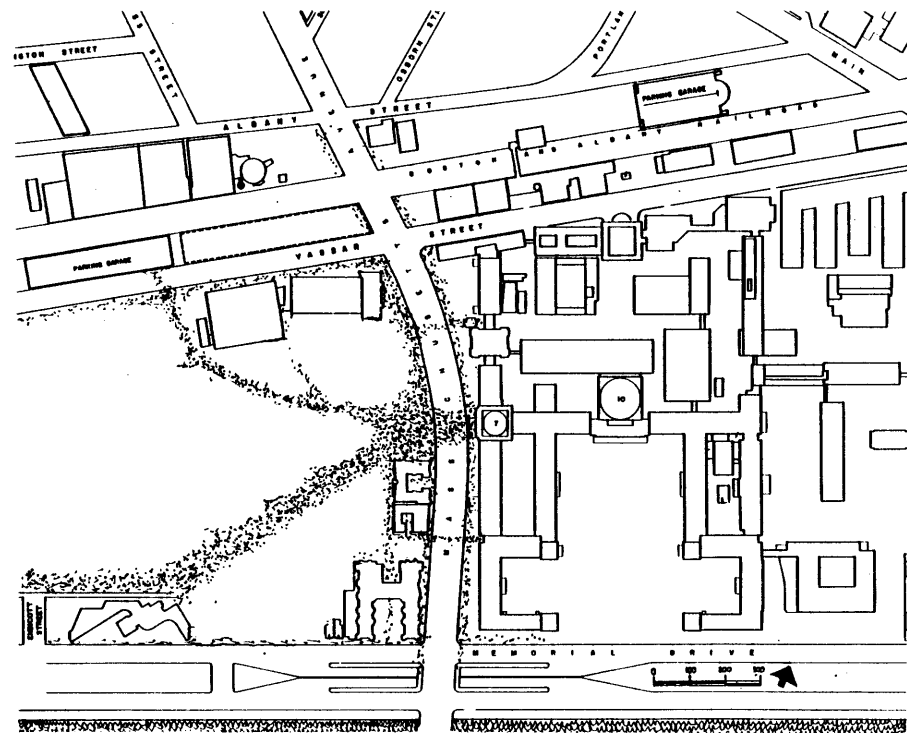

7. Pedestrian movement.

Design Process

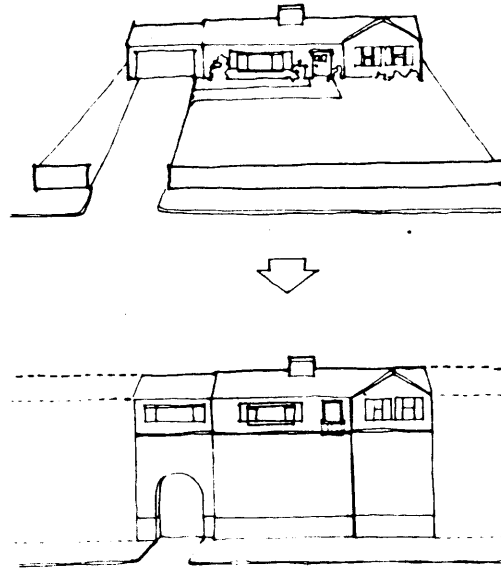

Figure 8

The front yard is wasteful as a functioning extension of the street. It is not the outdoor extension of the inner private space that it pretends to be. It is neither public nor private. It has many of the qualities of a wall; impenetrable, indicating privacy. But this wall is laid out horizontally - it becomes confusing as a result. Compare this with the ground level of the palazzos in Florence, which in trying to portray a similar message, make the edge much clearer for everyone.

Figure 9

A clearly defined front yard,



9

Until 1962, a commercial strip existed along Massachusetts Avenue across and to the north of the Rogers Building. It was set back only enough to provide a fifteen foot sidewalk. Soon after it was removed, the existing student center was built much farther back from Massachusetts Avenue, leaving in between a large green space. This added to the progressive breakdown into parking and empty lots, and unclaimed green space of the street edge that extends approximately 300 yards to the north along Massachusetts Avenue.

Although rebuilding the street edge in front of West Campus isn't enough to re-establish the rhythm set up farther north along Massachusetts Avenue, it begins to



Figure 10
Old "Tech Block".

establish clear territories.

In the initial schemes the proposed building along Massachusetts Avenue is entered along its west side in response to the interior 'campus' shopping street. The Massachusetts Avenue side provides visual access in and creates a back for the street, to sit along or to find protection from the weather in waiting for a bus or taxi.

INITIAL SITE STUDIES

First Pass

Figure 11

The first pass at the site shows buildings backing up to Vassar Streets' impenetrable 'wall', creating a more habitable wall along the new edge. Major pedestrian movement passes along this wall which is shown in the diagram as a forest at the base of a mountain. Sec-

dary movement passes between a larger and smaller mountain, through a canyon-like space.

Figure 12

In a later study major movement continues along the building edges, with secondary access moving 'through a piece of the building'. The large open green space gives pedestrians time to see where they're about to go before having to turn.

Outward focusing activities such as shops, workshops and eating places occur along the

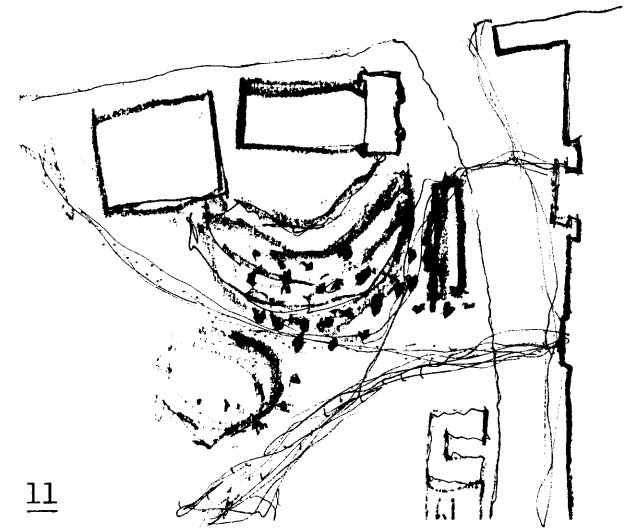

street and serve to buffer and connect inward focusing cells such as gymnasiums, auditoriums and chapels. Access to activities on the second level occurs along the outdoor street aswell.

This scheme blocks visual access to the playing fields and makes a public space within one of the buildings that is oriented away from the street.

In order for a public square to work, the focus of all of these buildings must be oriented toward it. People gravitate naturally toward the edge of public spaces. They do not linger out in the open. If the edge does not provide them with places where it is natural to linger, the space becomes a place to walk through, not a place to stop. It is therefore clear that a public square should be surrounded by pockets

of activity: shops, stands, benches, displays, rails, courts, gardens, news racks. These pockets should all be next to paths and entrances so that people pass right by them as they pass through. The goal-oriented activity of coming and going then has a chance to turn gradually into something more relaxed. And once many small groups form around the edge, it is likely that they will begin to overlap and spill in toward the center of the square.

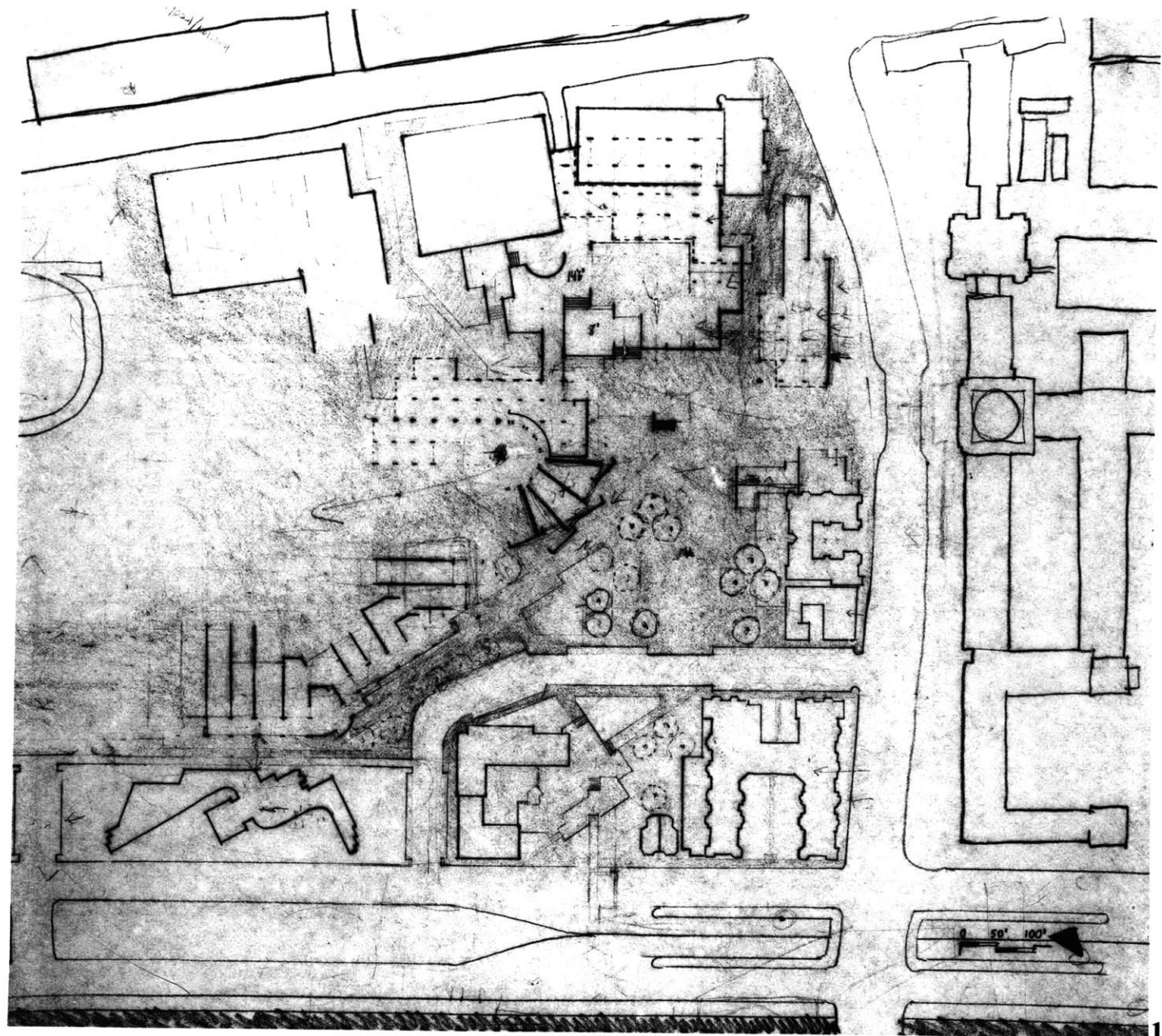

Second Pass

Here, ground level activities begin to focus on the street as the collective space. Although a view through to the

playing fields is possible, visual access to the river is now blocked.

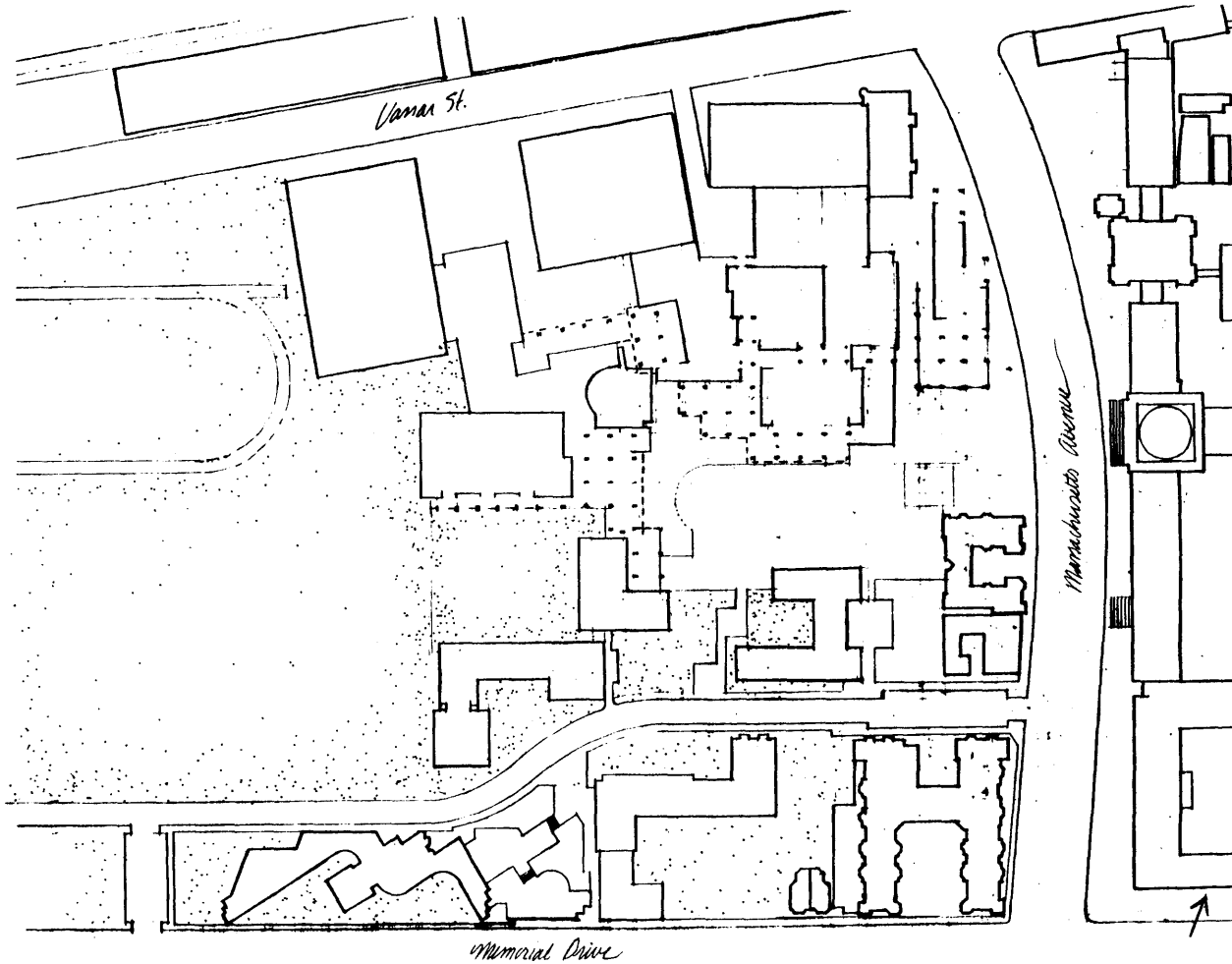

Third Pass

Figures 14-16

In each of the following cases collective pockets are introduced as a way of making a turn in the path. They end one of the two directions and serve as a secondary focus in the journey through. They are bypassed by circulation and therefore have placemaking potential.

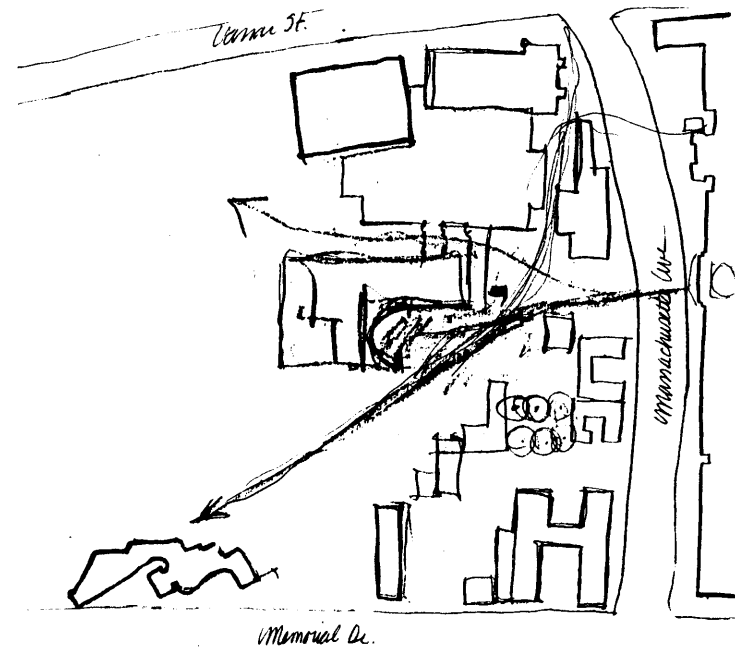

Figure 14

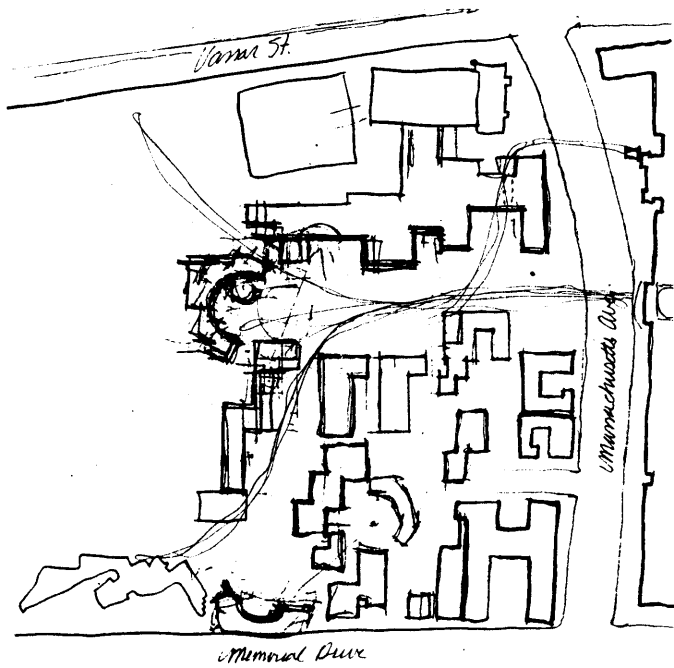

Figure 15

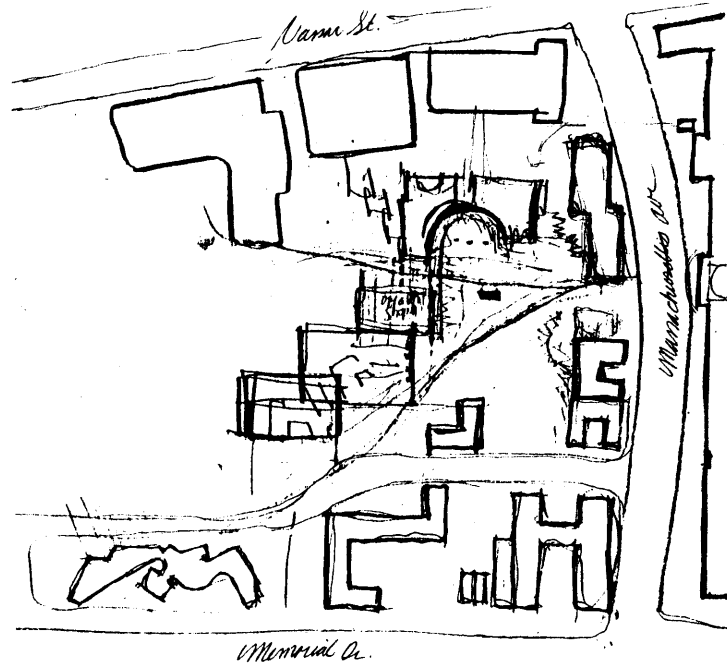
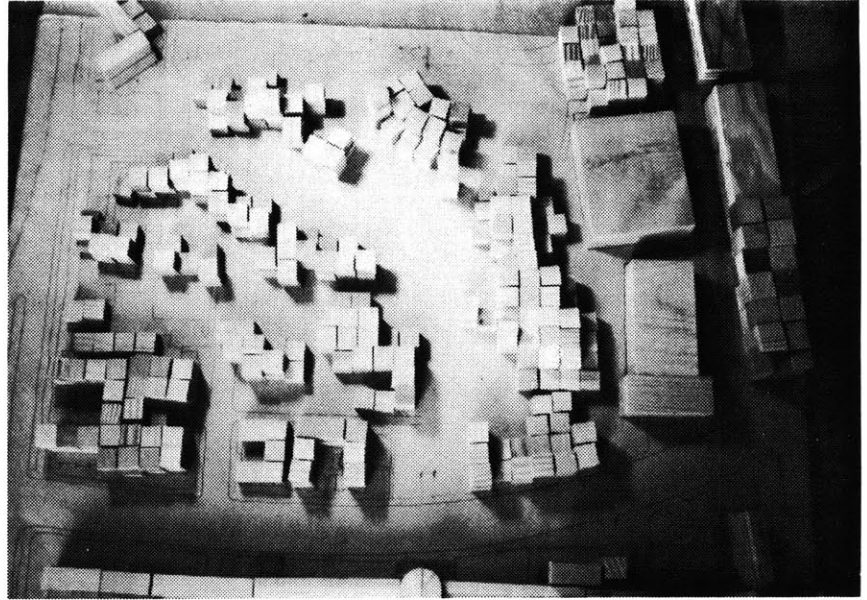

Figure 16



17



18

Fourth Pass

Figures 17-18

In the previous studies, the buildings weren't clearly responding to the major site references. The block studies clarify two major site directions. The buildings to the north run in the east-west direction. As the most public buildings on the site they maintain maximum contact with the public edge as their long dimension occurs along the public street. This direction also reinforces the connection with the playing fields. Since buildings to the north of this act as a wall to any further growth in that direction, and since they contain and respond to inward focusing activities (gymnasium and warehouse), the new buildings act to create an active buffer between them and

the pedestrian street.

The buildings to the south side of campus are oriented in the north-south direction. Their direction allows visual and physical access to the river. They tend to be less public in character, with some shops and workshops at the ground level and residences above. In moving along the main street, one passes their short dimension.

Figure Ground Studies

Figures 19-20

Each of these studies starts to examine the relationship of the two perpendicular fields and how their arrangement might influence a turn in the main path toward the dormitories along Memorial Drive. In the diagram to the right a secondary street is indicated. This version

could only work if the piece between both streets is transparent with visual and/or physical back and forth between streets at intervals.



19



20

Fifth Pass

This series of sketches explores alternatives for organizing the site, this time incorporating both Kresge and the Chapel. These forms are helpful in making a change of direction.

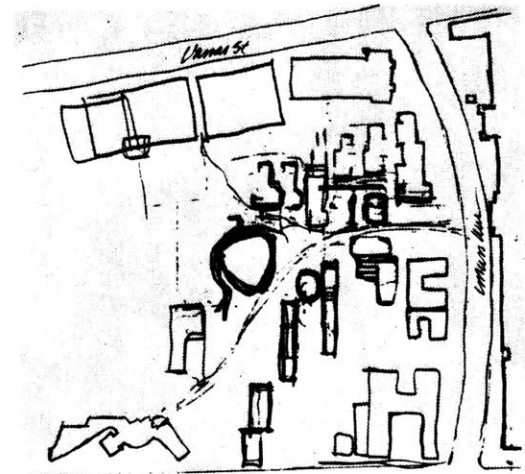

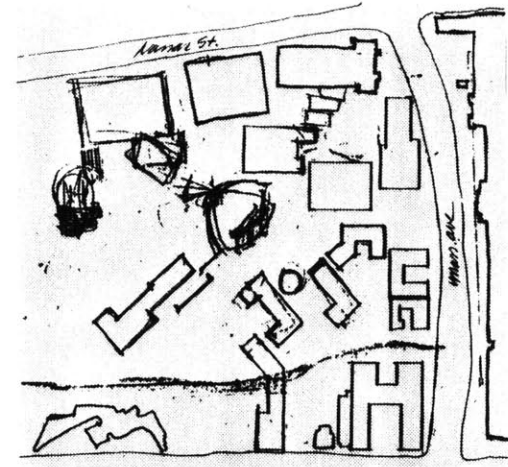
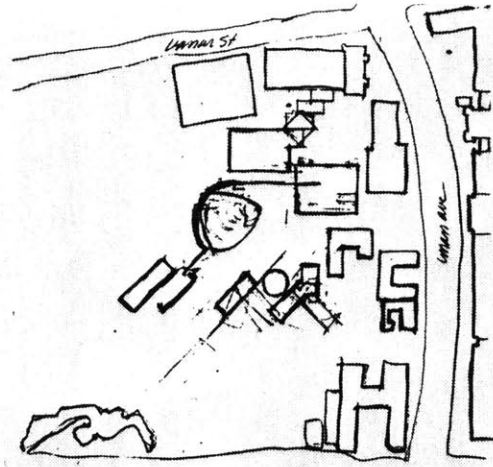
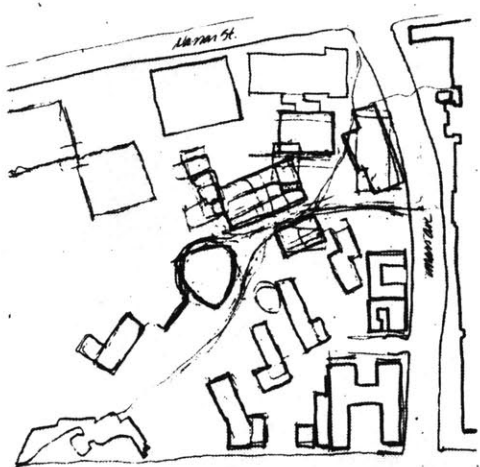
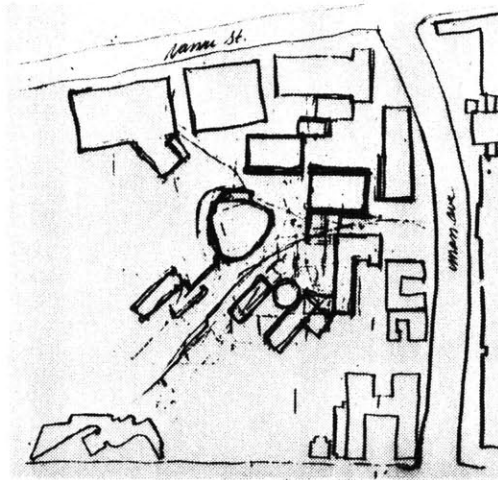
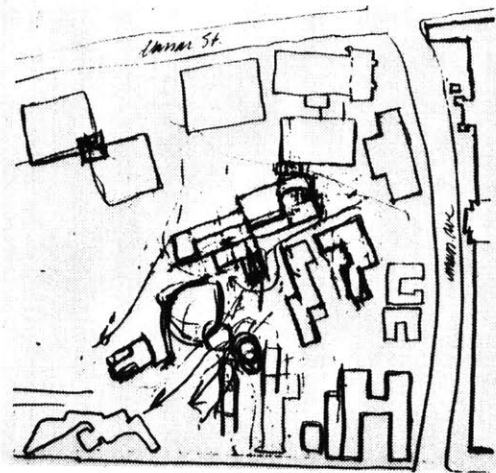
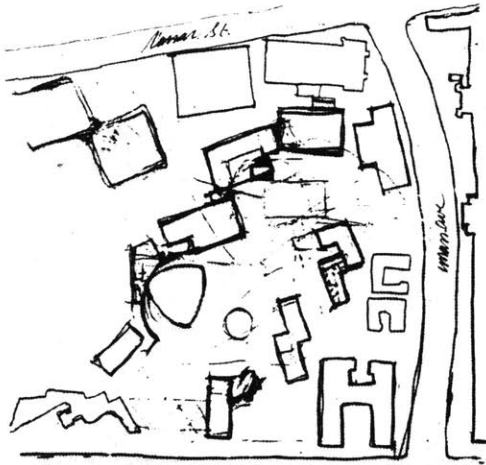

STUDIES FOR THE STUDENT
CENTER

In each of these explorations, shops occur along the outside perimeter of the building at street level.

A- shops
B- Coop
C- storage
D- delivery

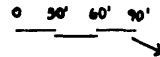
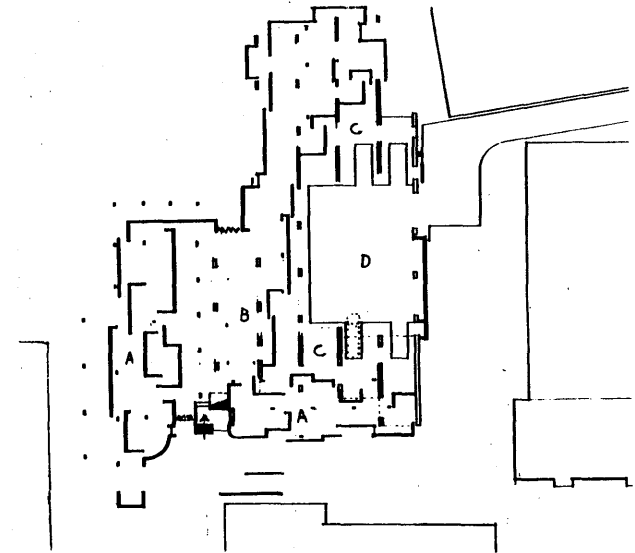

Figure 28

. The building is arranged orthogonally with the Coop occupying the center and smaller shops along the street. Access to each shop is from the street and to the second level from outside stairs on the east side of the building. Truck delivery occurs along the north side.



Figures 29-30

. An attempt at giving the shops their own identity.

Figure 31

. Both stores now have direct access to storage and truck delivery. Entrance to Coop now along main street.

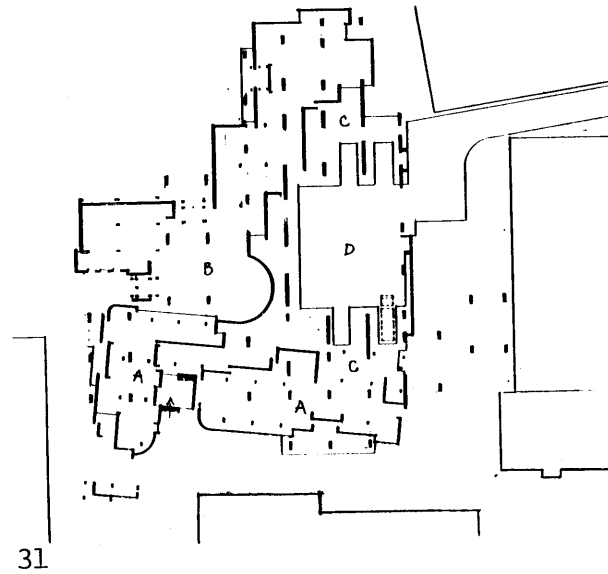
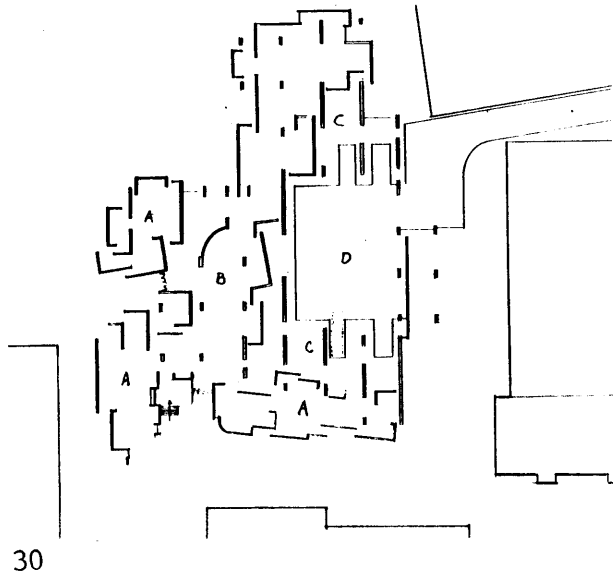
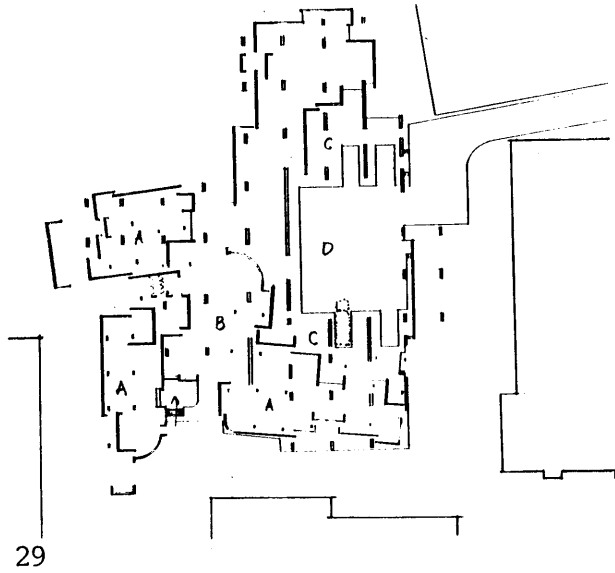

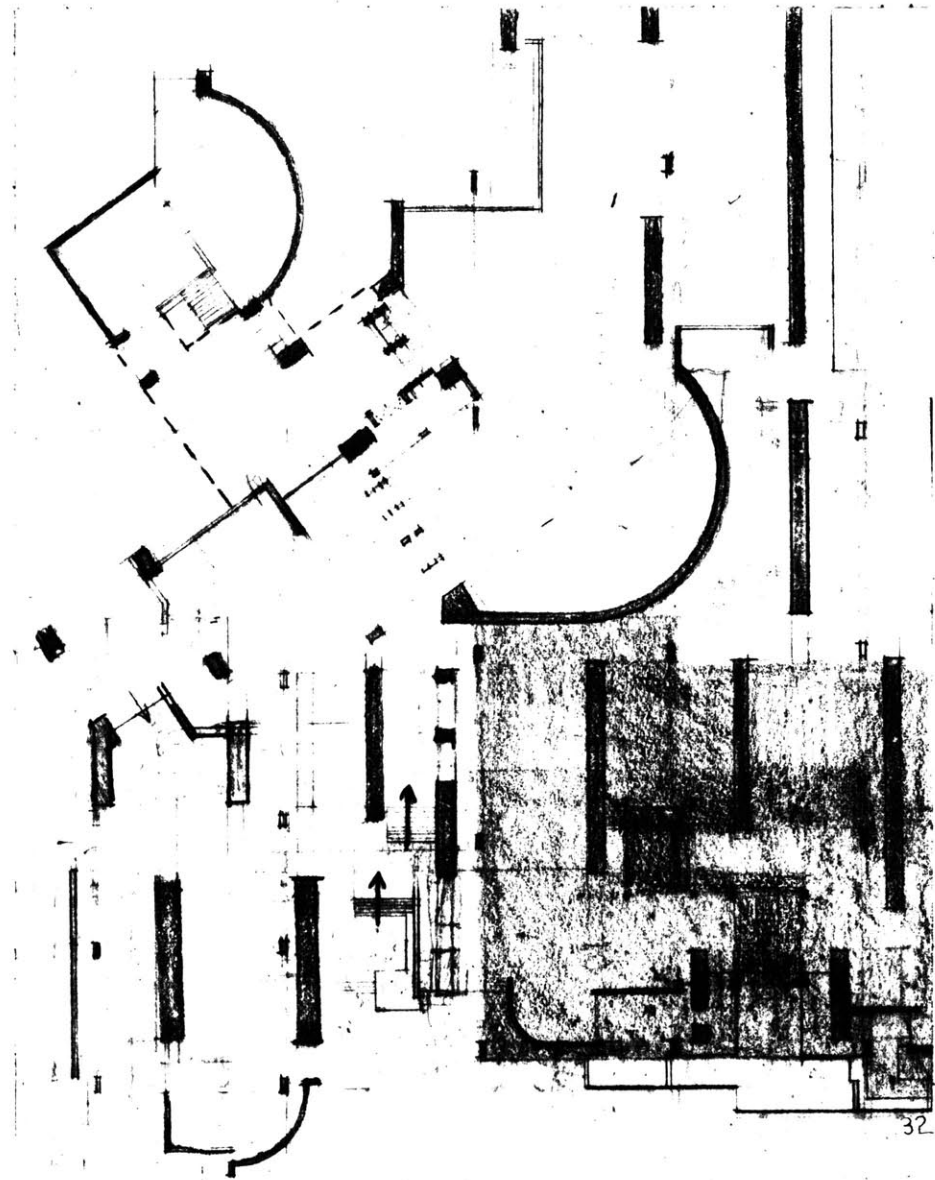

32

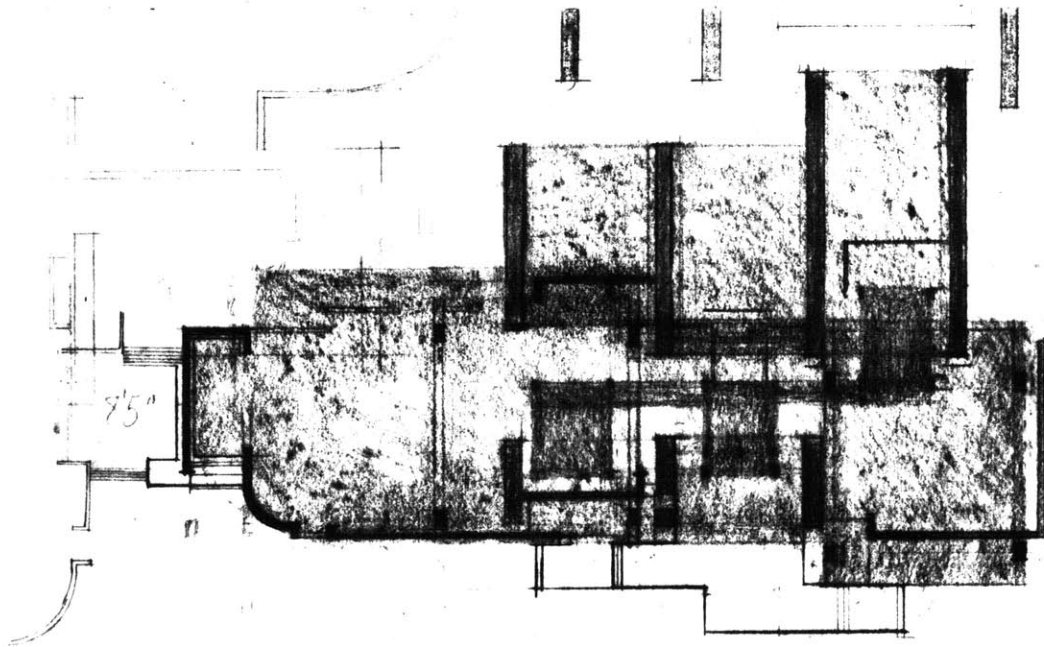

33

Figure 32
Typical shop with access from
the street.

Figure 33
Building interior acknowledges
second site direction.

BUILDING COMPONENTS

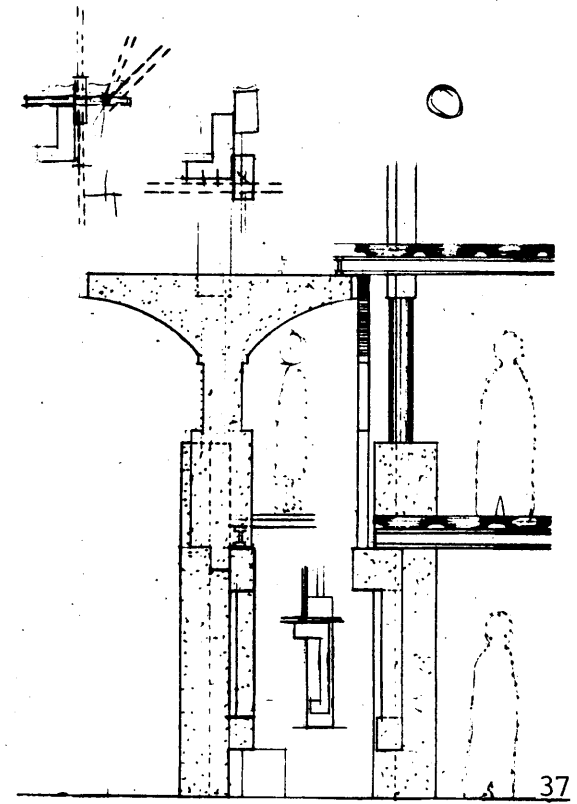
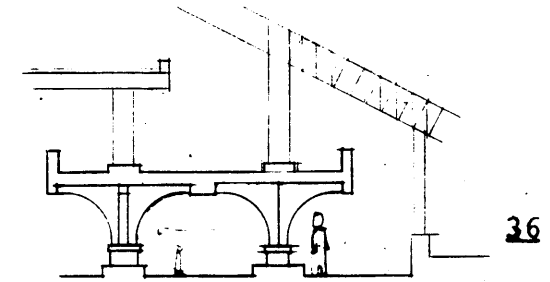
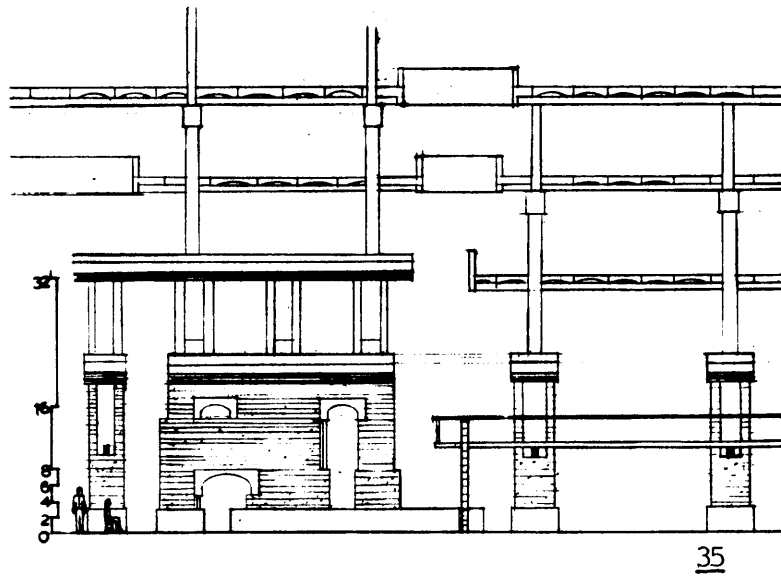
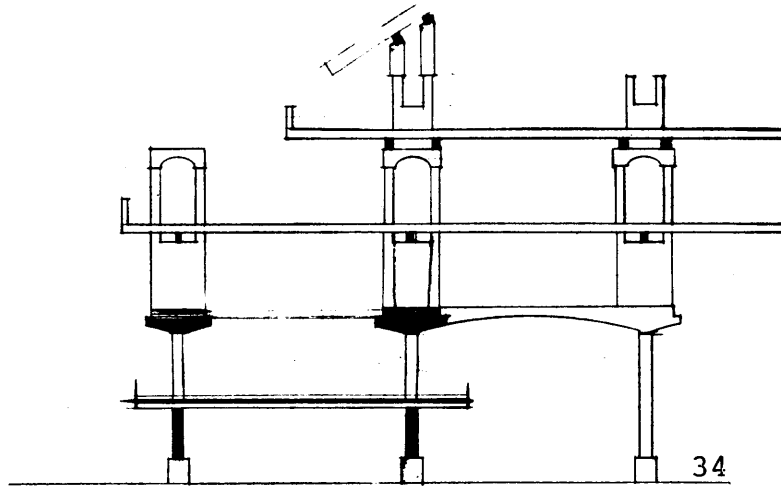

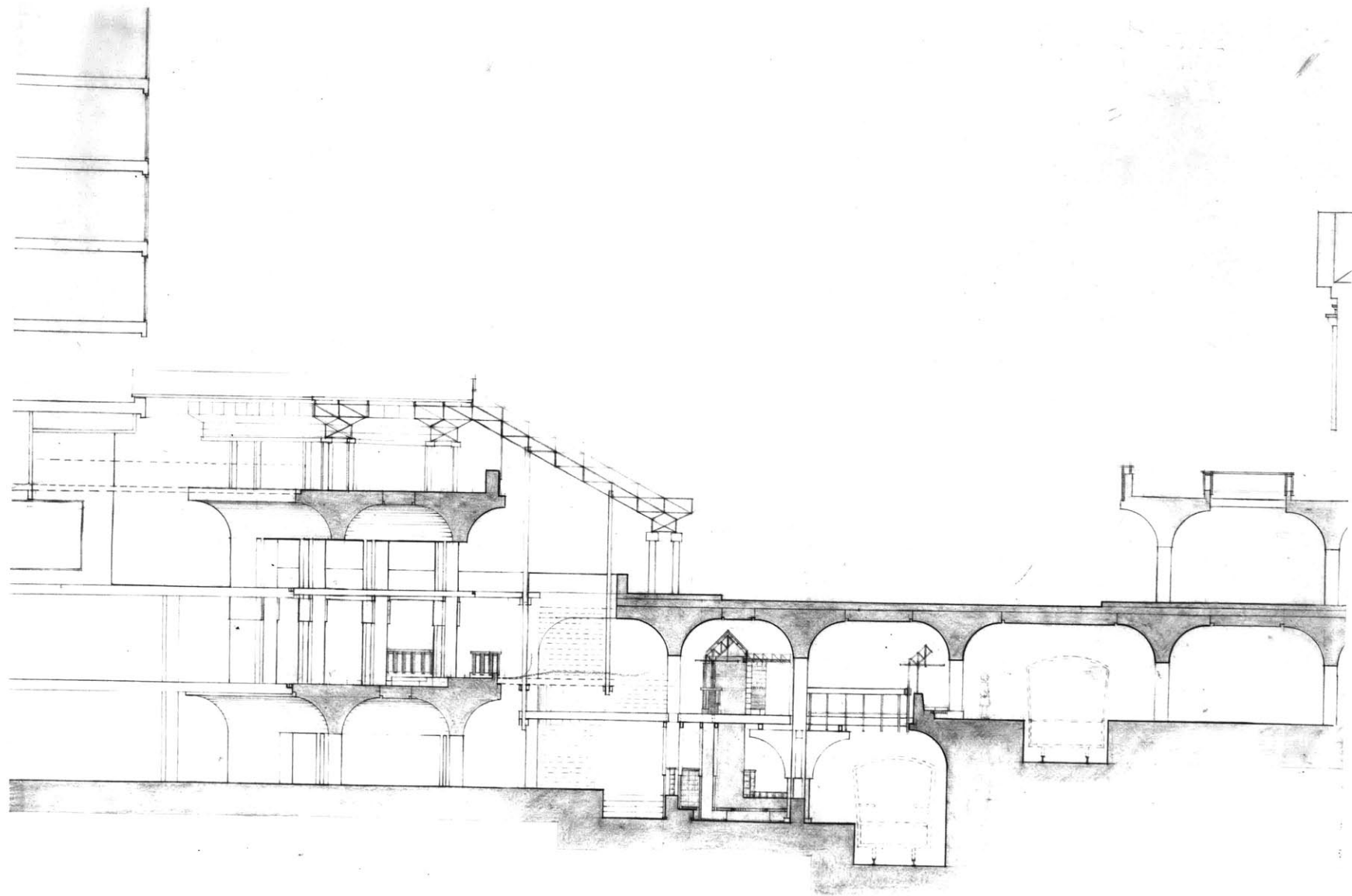

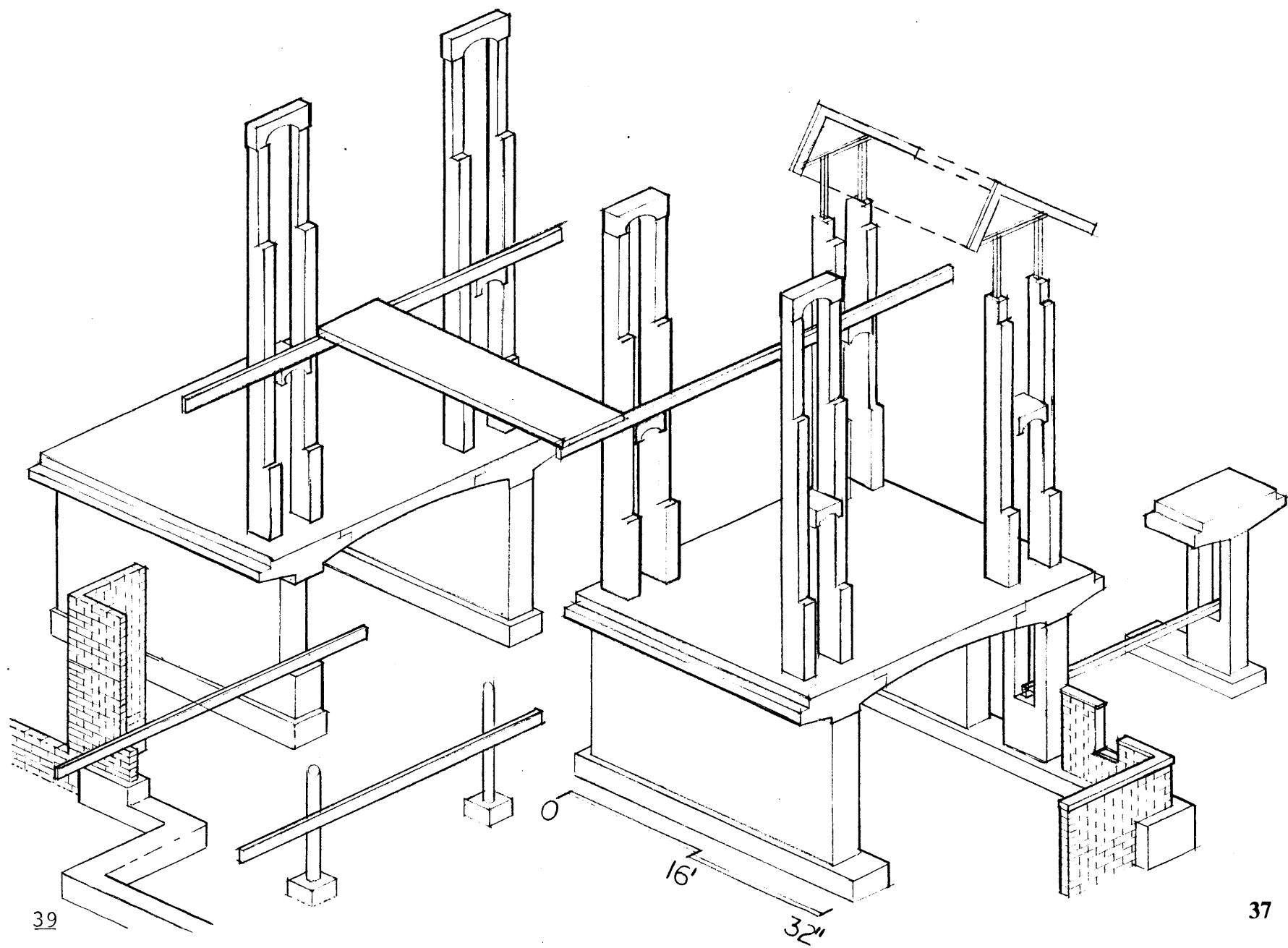

39

37

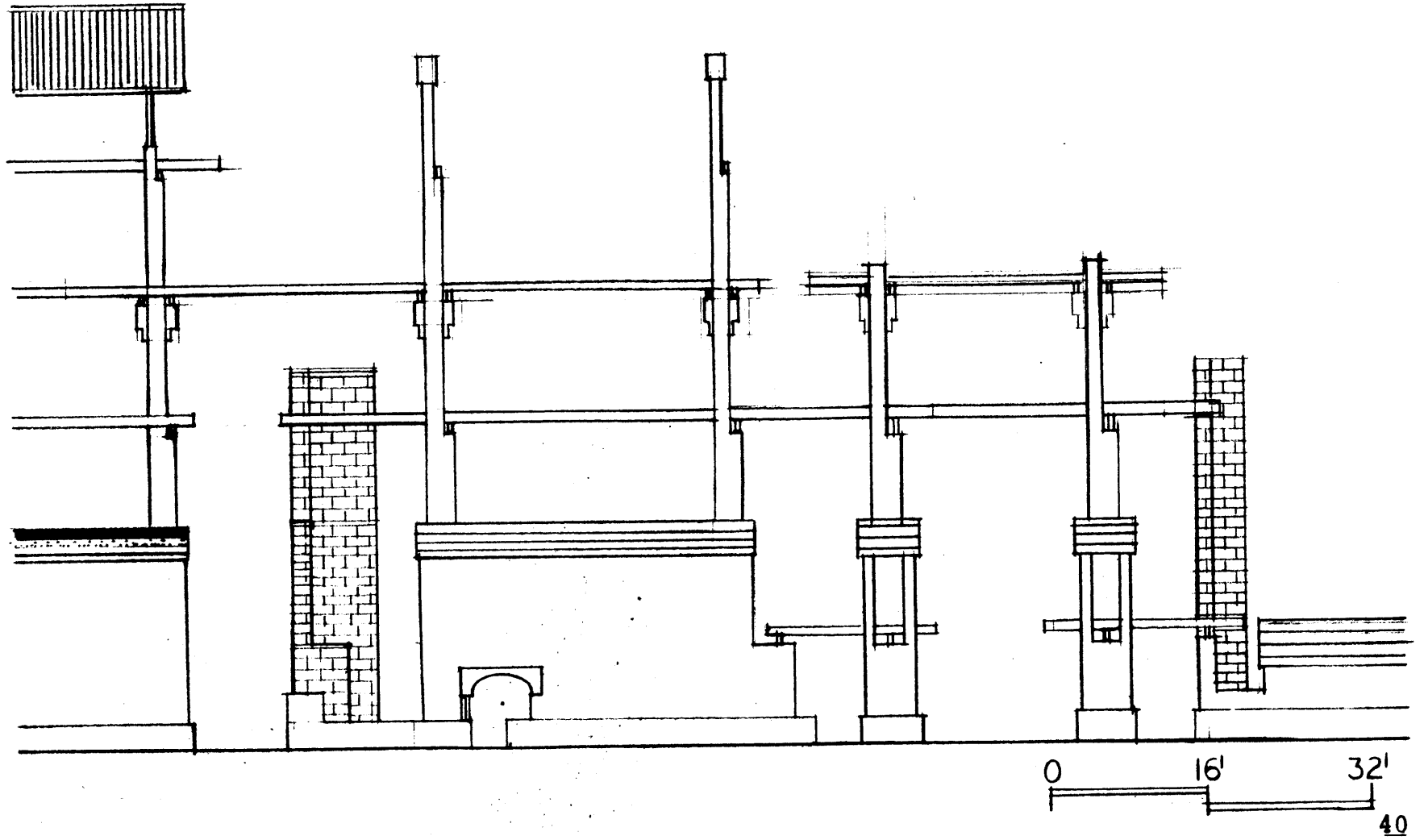

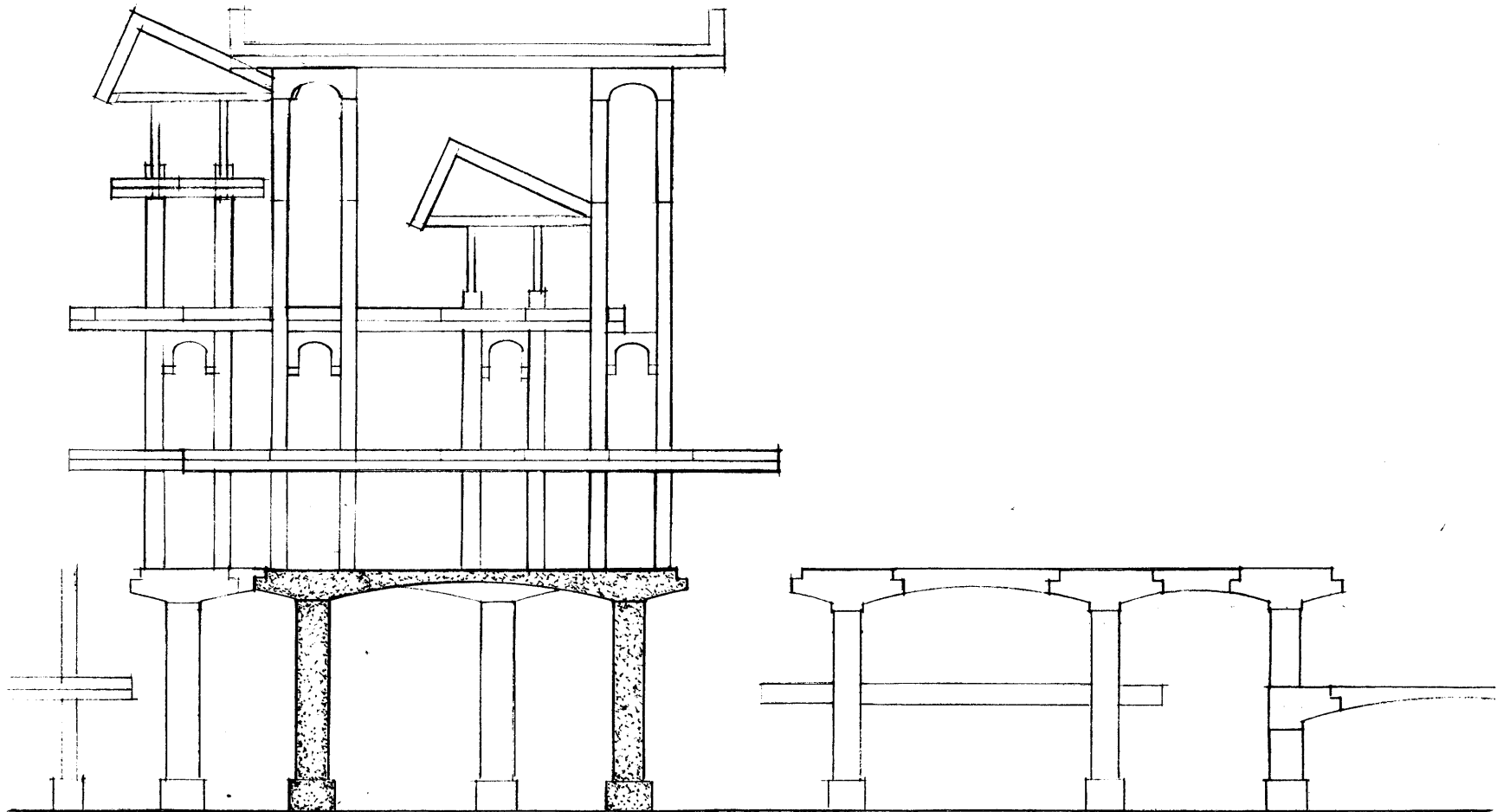

41

39

Figures 42 -44
Study model of a piece of
the student center.

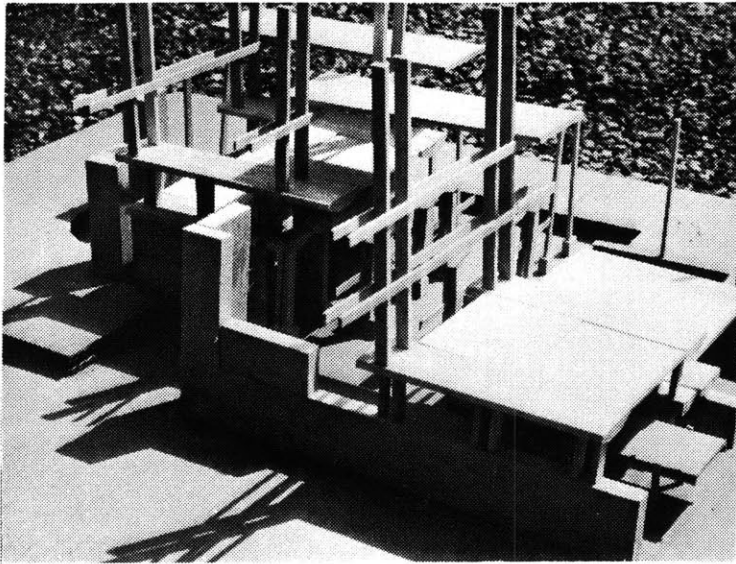

42

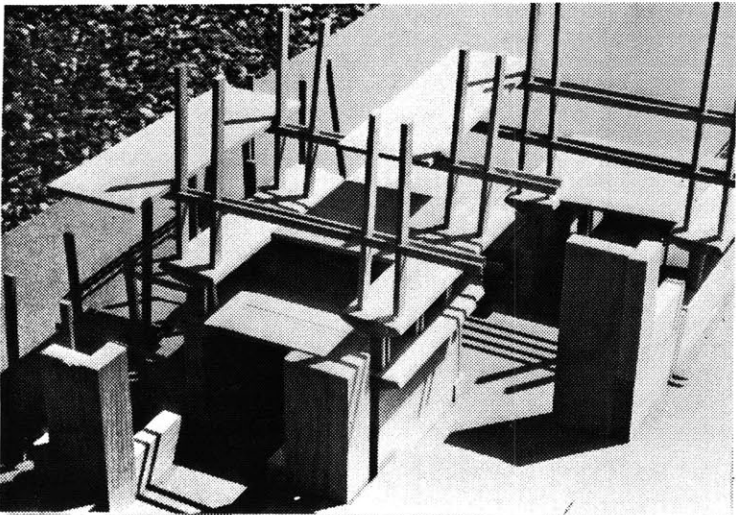

43

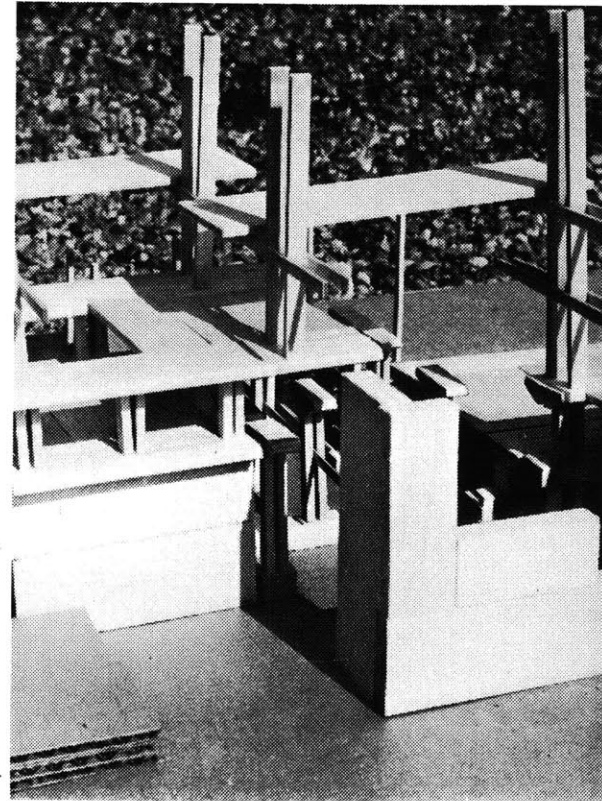

44

41

Figures 45-47
 The following diagrams are a systematic pass exploring some of the edge zones that are created by moving the enclosure relative to ground and structure. Relationships are ex-

plored at 1'6", sitting height; 3', a height one can view over while sitting; and 6'8"+, a height that blocks views.

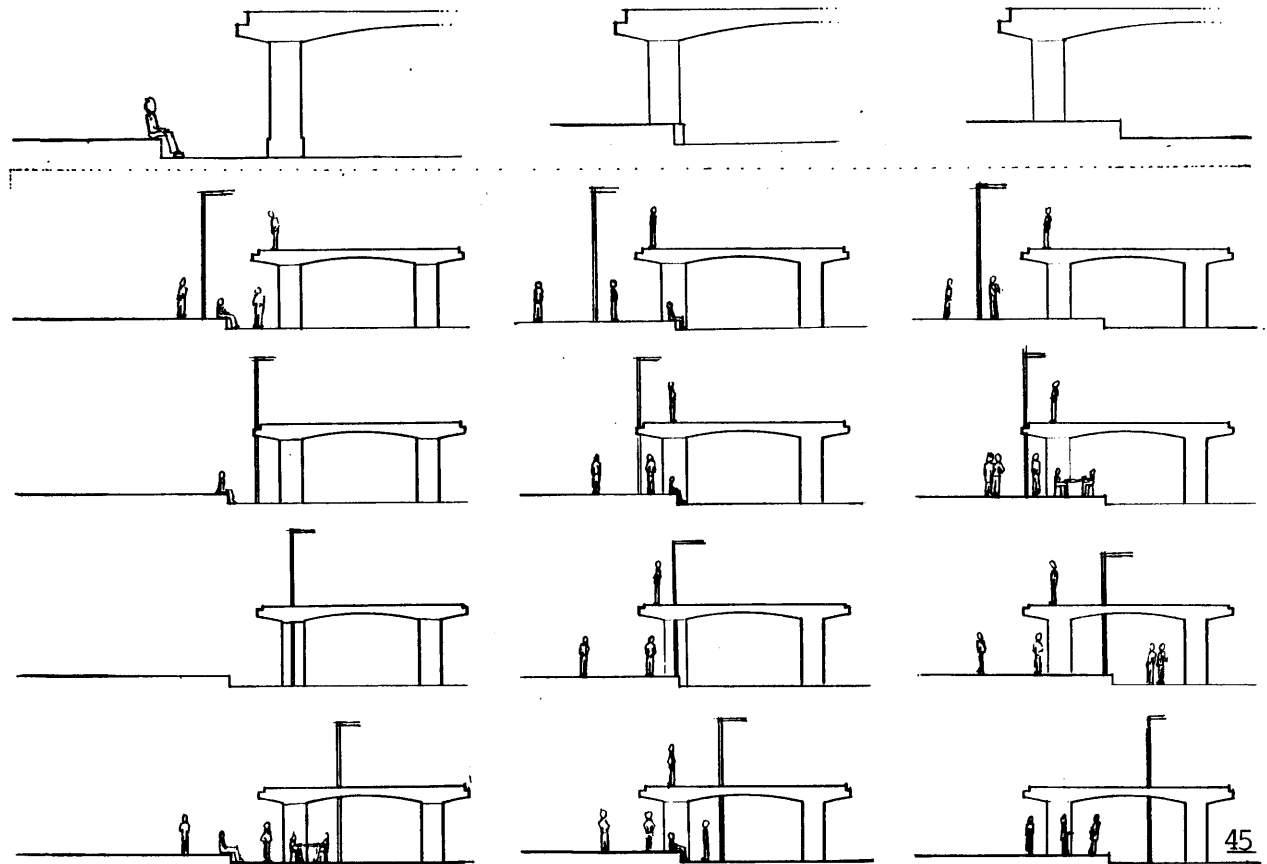

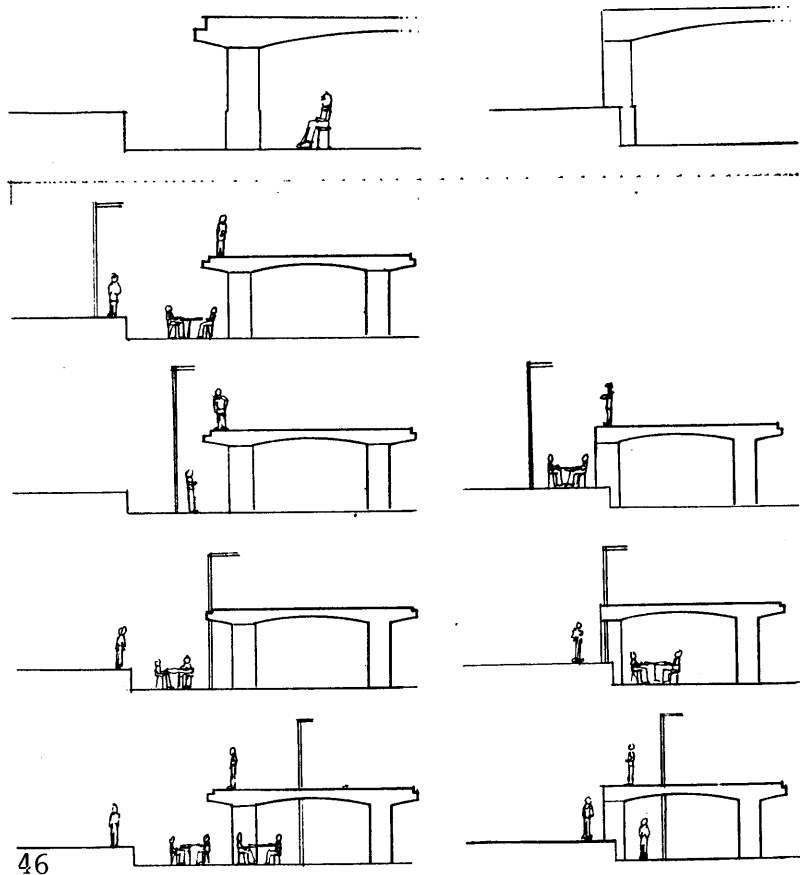

46

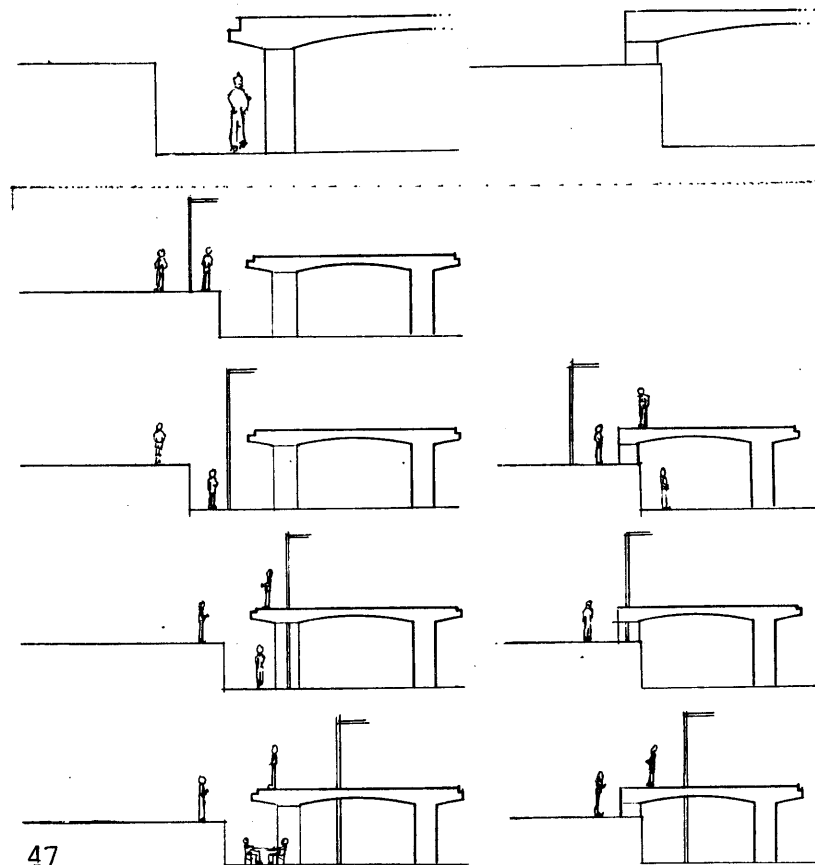

47

43

Schematic Design Proposal

Figure 48
Site Plan

Figure 49
Plan of main street.

Figure 50
Plan of main street.

Figure 51
North elevation along street.

Figure 52
Section through street.

Figure 53
Section through outdoor steps
leading to second level.

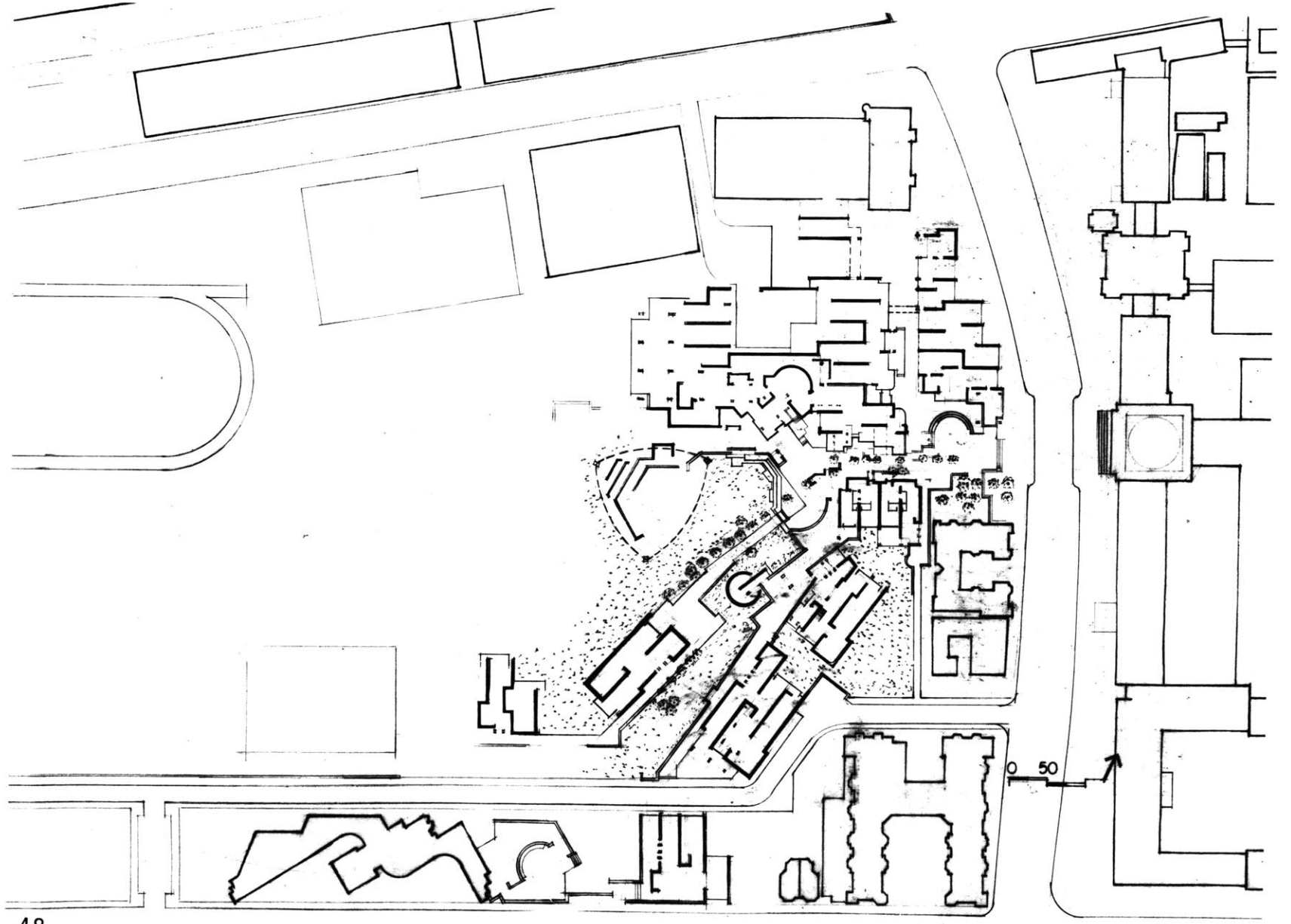

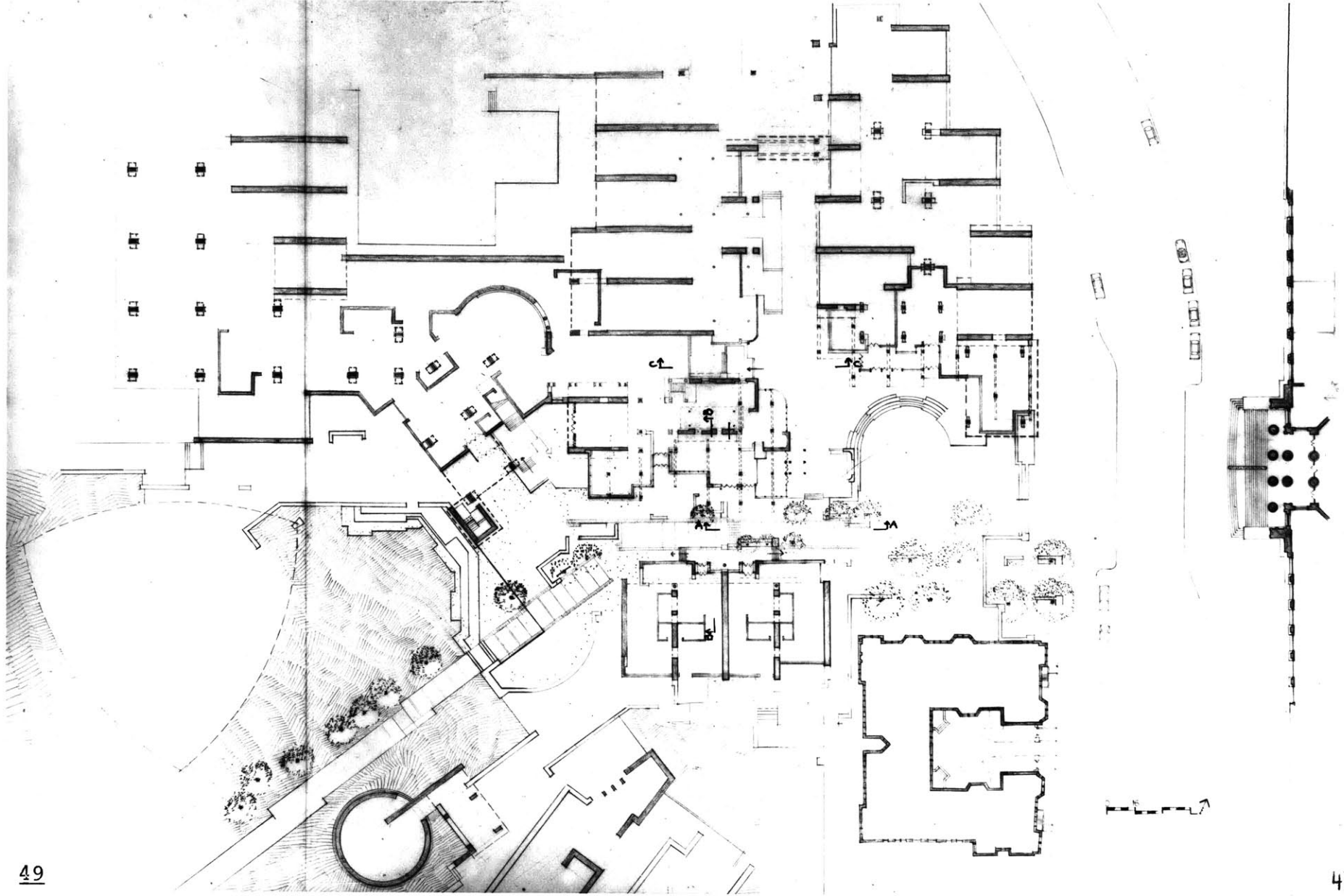

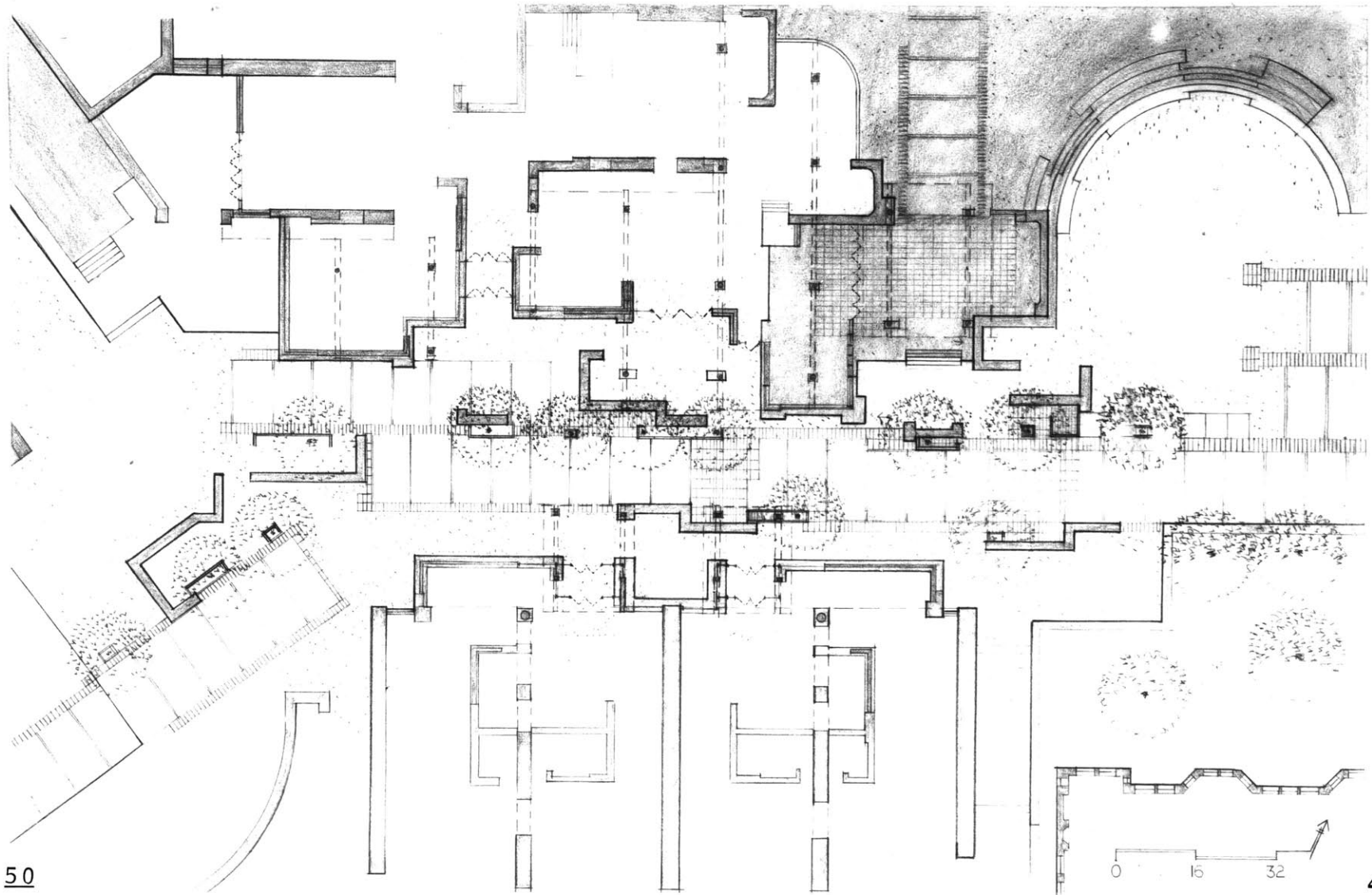

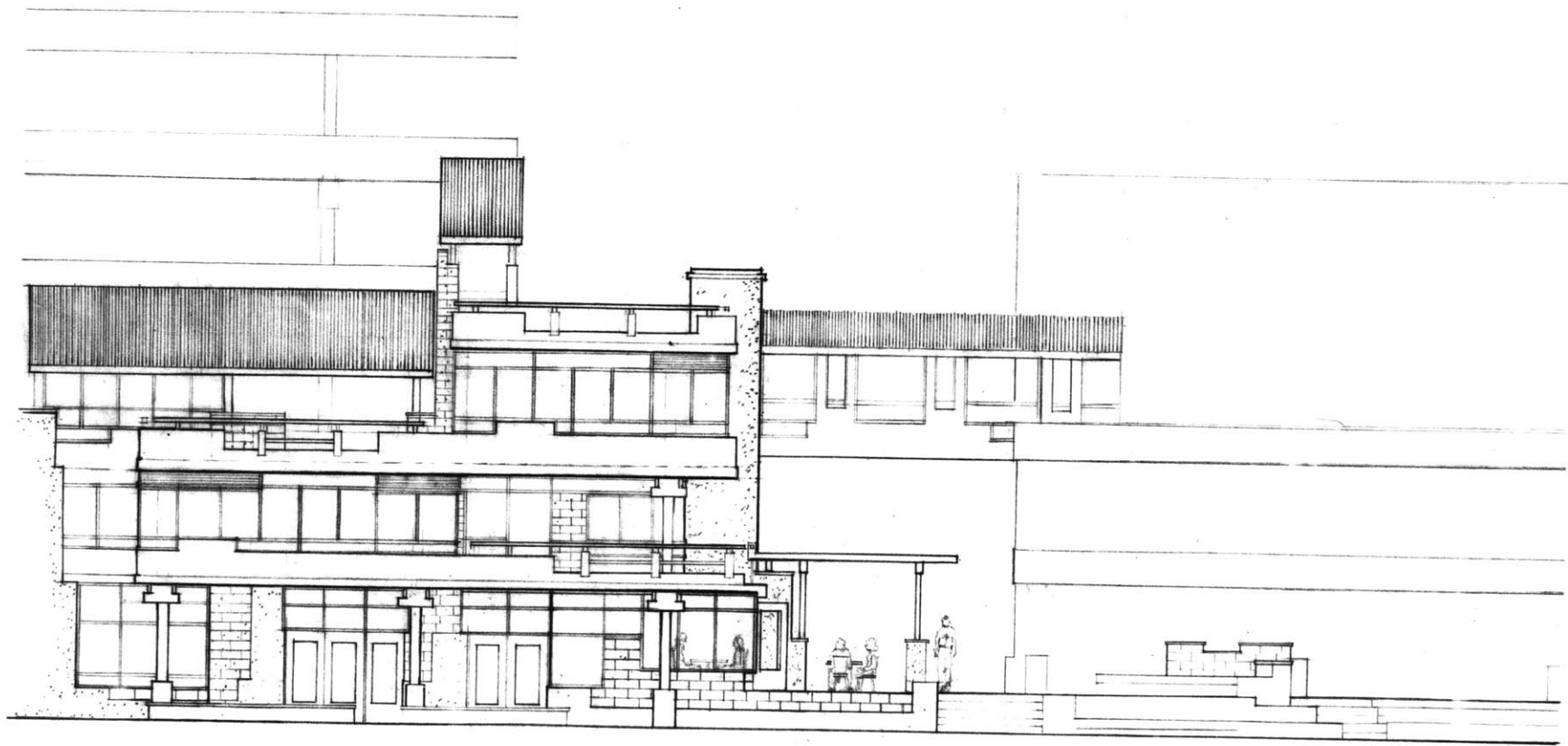

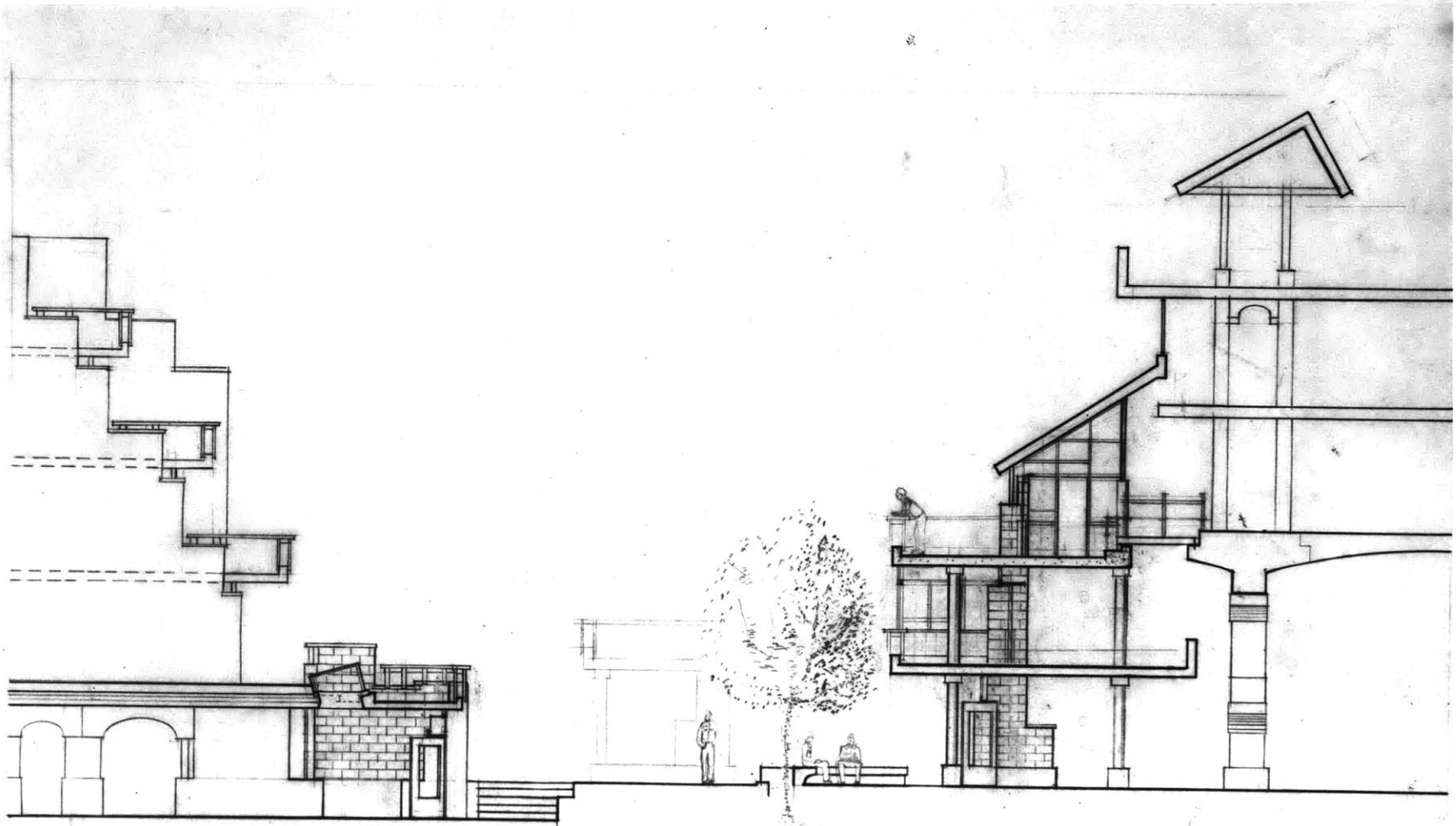

0 4' 8' 12'

B-B

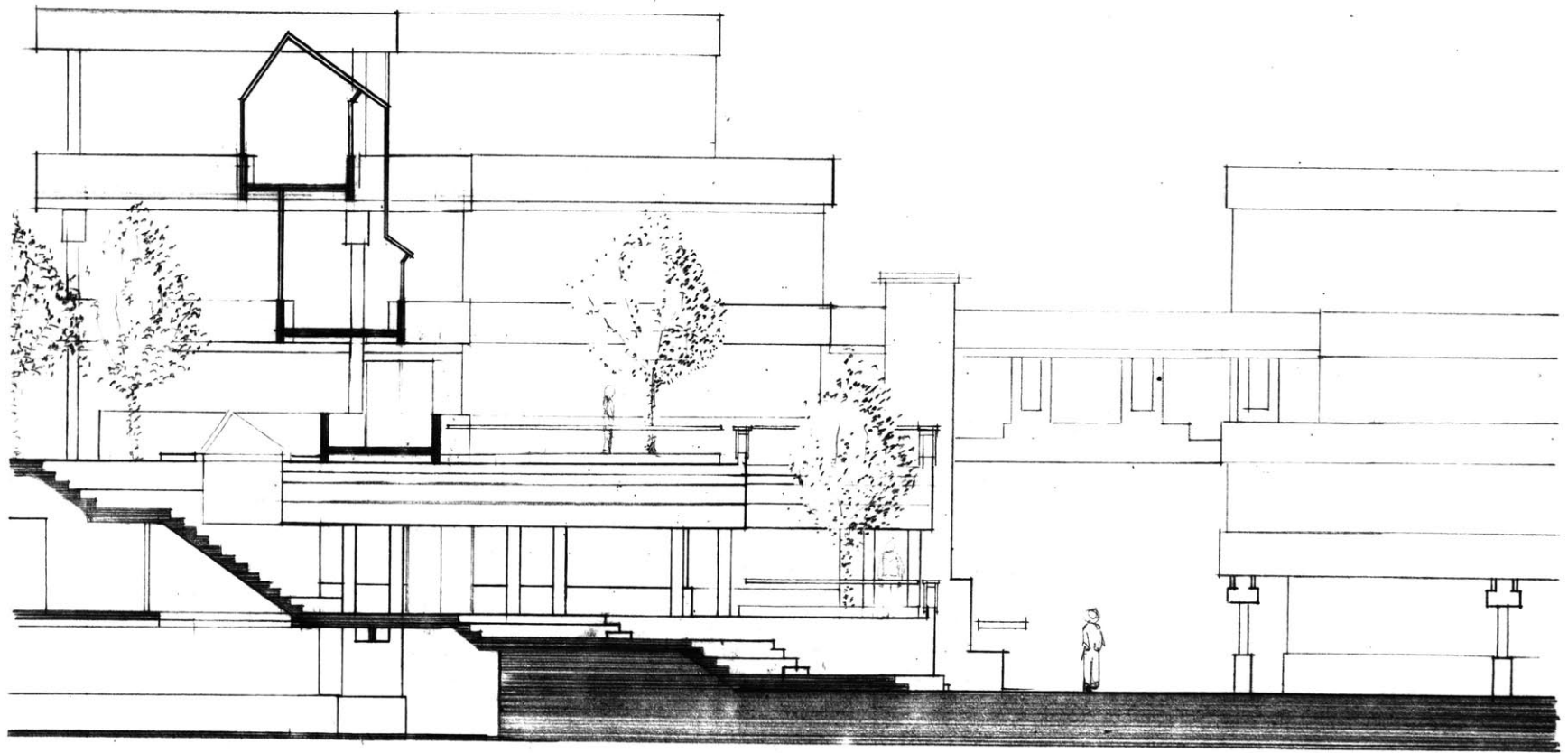

C-C

Aspects of the Street; Patterns.

Following are suggestions, with examples that should be taken into account when designing the street framework.

1.

If indoor staircases, corridors and lobbies are eliminated so that most of the circulation occurs outdoors, or is perhaps directly associated with the outside edge of the building, then this will help to generate an active pedestrian street. Entrances to small and large shops, workshops and eating places as well as access to the upper levels, should occur directly from the street.

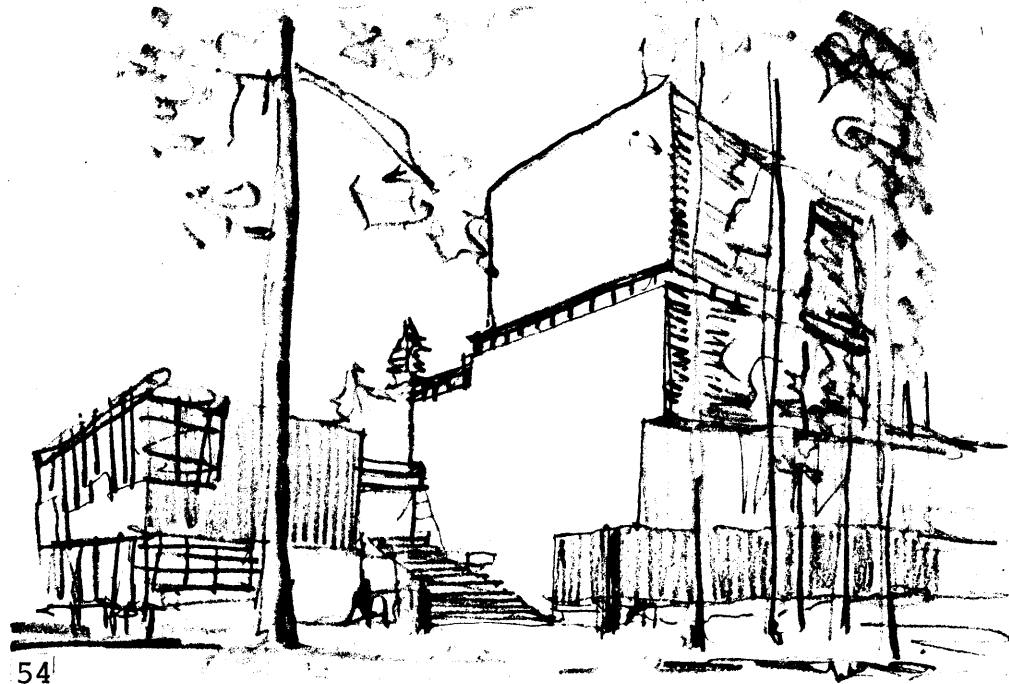

54

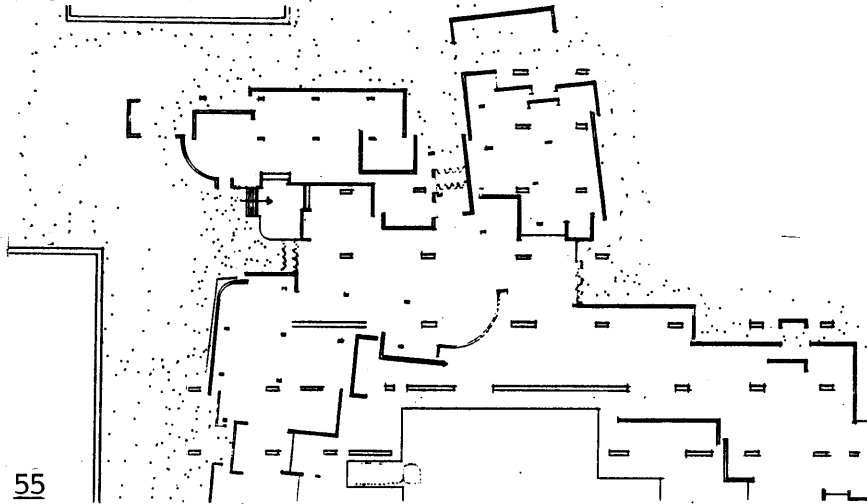

55

57

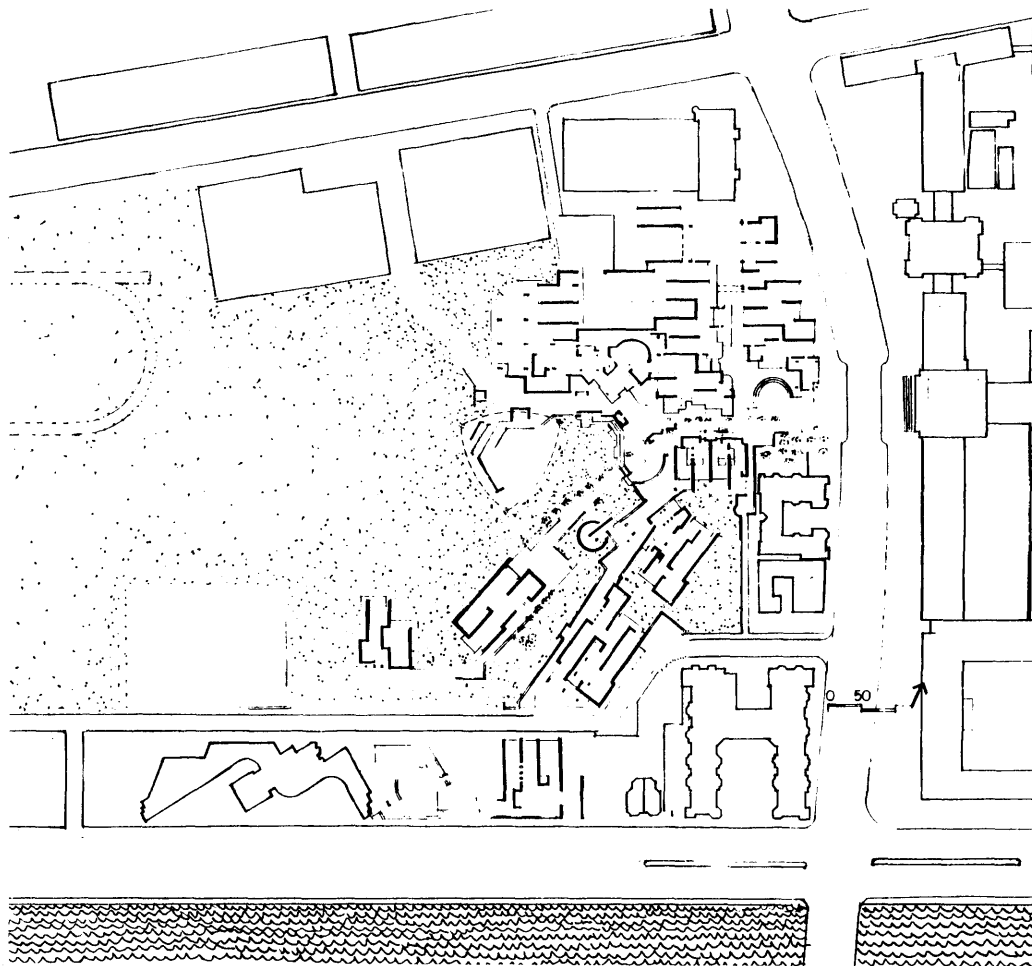

2.

Major site landmarks that can be associated with either directly or indirectly when moving along a street, help to make clear a person's whereabouts in space. For instance, if the street is perceived as part of a coherent succession of spaces, textures and/or objects that together comprise a greater whole, and if this whole has a clear relationship to a landmark, this provides an indirect association.

A landmark is strongest if "visible over an extended range of time or distance and more useful if the direction or view can be distinguished. If identifiable from near or far while moving rapidly or slowly, by night or day, it then becomes a stable anchor for the perception of the complex and shifting urban world."

Figure 57

The Duomo in Florence "is a prime example of a distant landmark: unmistakable; dominant by size and contour; paired with a campanile in such a way that the direction of view can be gauged from a distance".

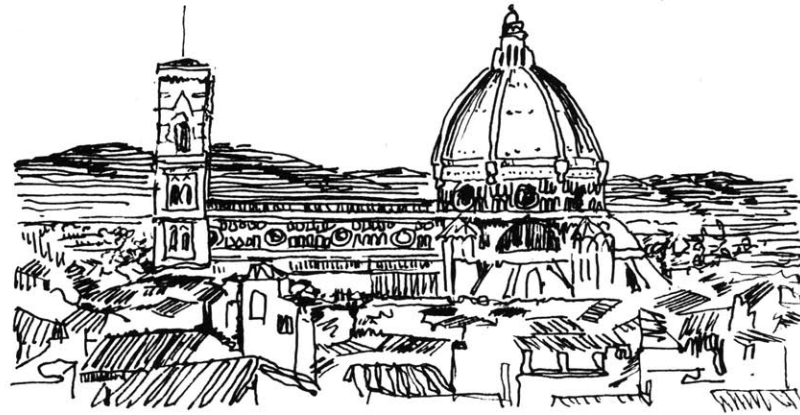

57

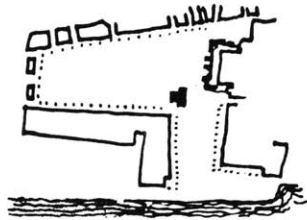

58

Figure 58-59

Although the water isn't visible from all parts of Piazza S. Marco, the tower, in its clear relationship to the water, provides orientation.



59

59

3.

Inward focusing cells shouldn't occur along the street. They should either be separated by distance or buffered with activities that maintain a more symbiotic relationship with the street.

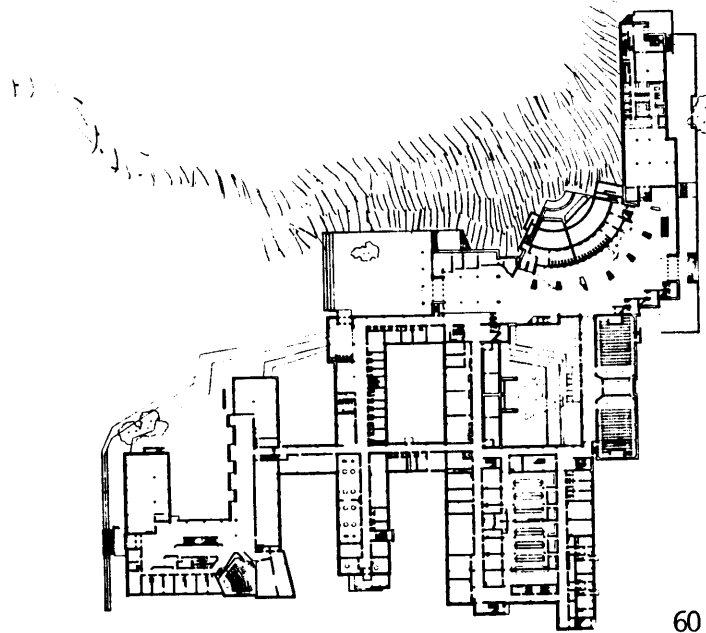

60

If an inward focusing cell is to occur along the outside perimeter of a building, it should be set apart from the street edge.

Figure 60

Main building, Otaniemi. Alvar Aalto.

Figure 61

Kresge meets the street only at its entrance.

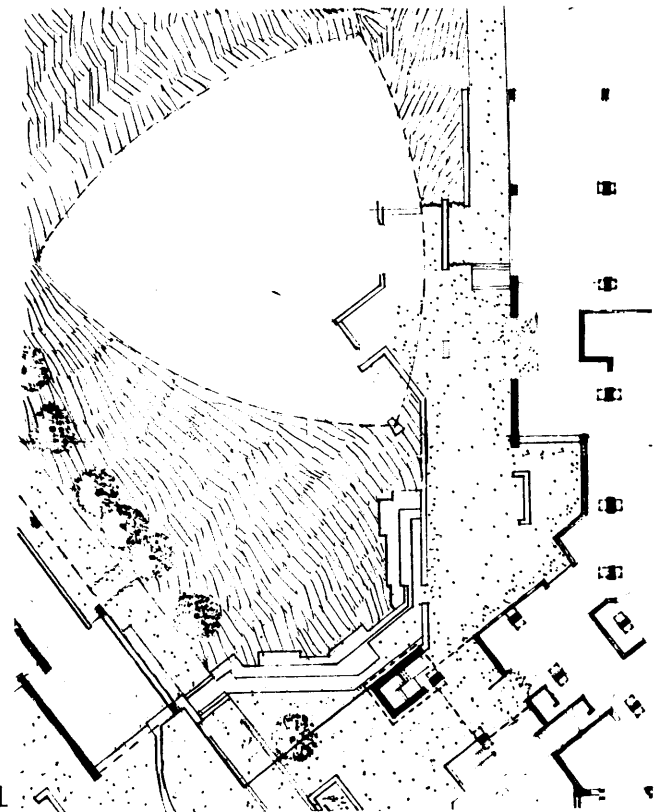

61

There are two basic use types that occur throughout the West campus. The inward focusing cells, both large and small, such as auditoriums, chapels and gymnasiums; and the outward or street

oriented cells such as restaurants, shops, offices, workshops and certain zones of the residences.

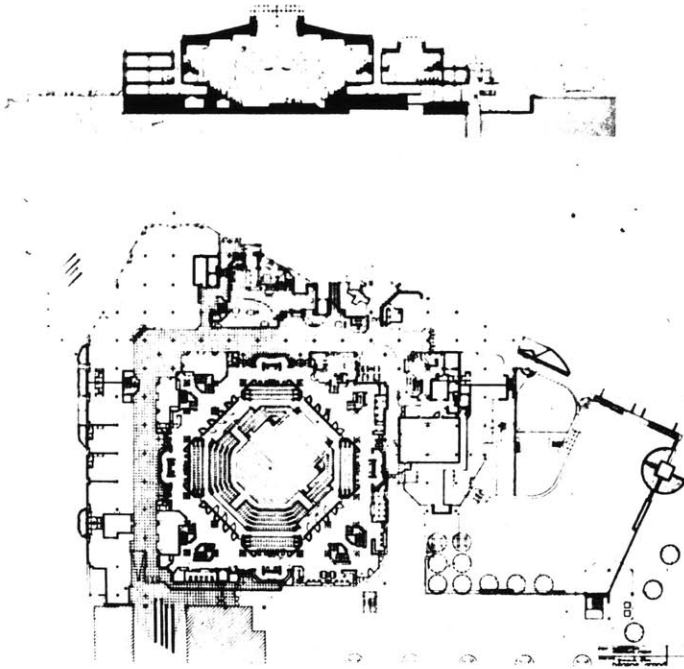

Figure 62
The auditorium in Herman Hertzberger's Music Hall in Utrecht, Netherlands is surrounded by shops at 'street' level.

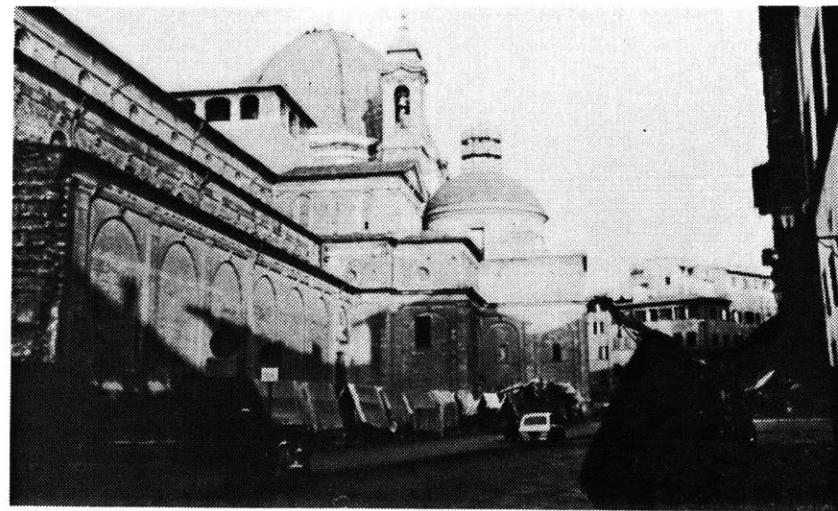
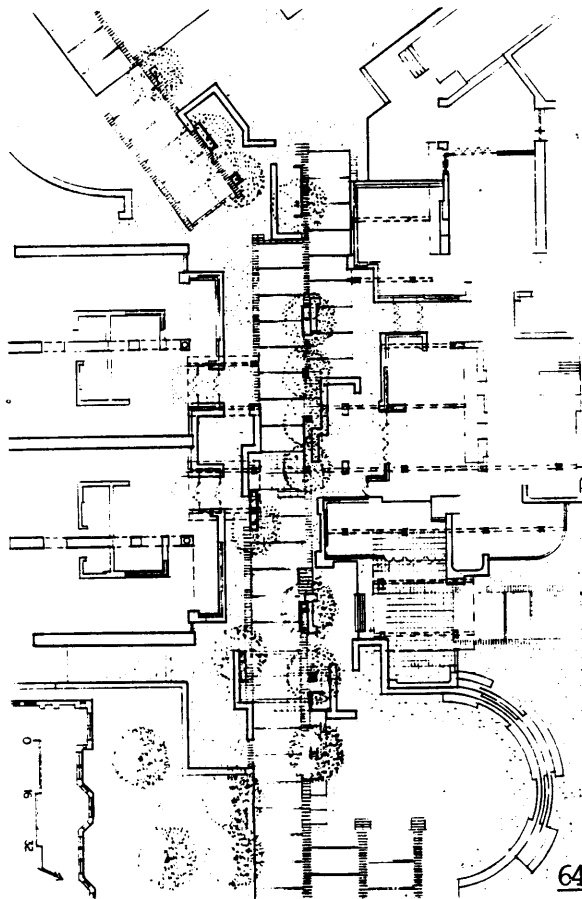

Figure 63
Vendors in Florence back their wares up against a wall of the Church of San Lorenzo, creating an active street edge.

4.

The distance between buildings should be a function of height and the need to get sun down to street level. In most cases movement through a street requires only a portion of this full width. The width needed for movement should be defined.

A reference for determining path width through west campus is in the main corridors of the east campus where the volume of people moving through the 9'9" corridors at any one time approximates the traffic that can be expected to move through west campus. Along streets that require access for emergency vehicles, clearance of no less than 16 feet is necessary.



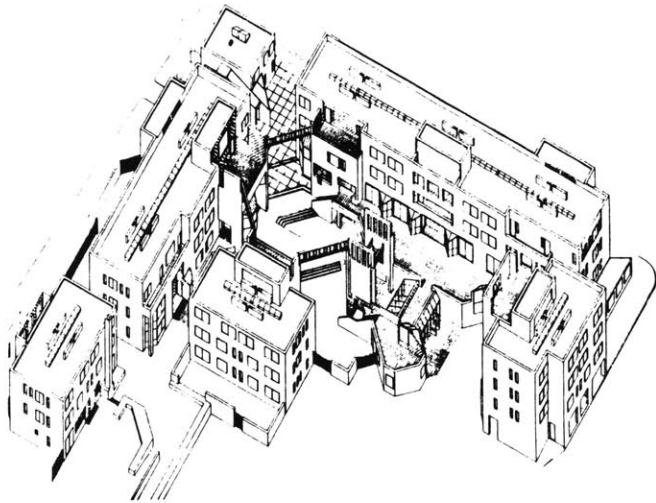

Axonometric view from the southwest

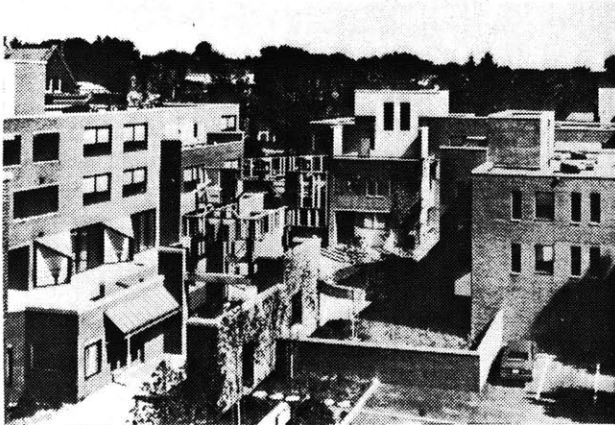
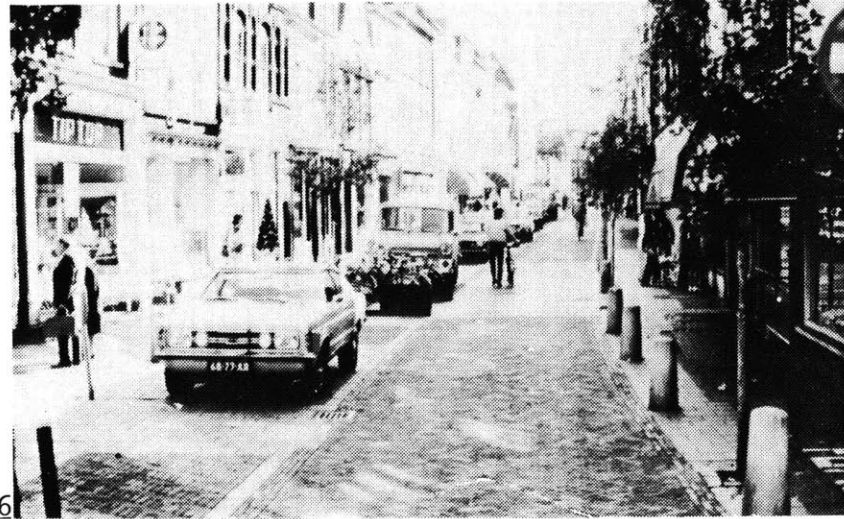

Figure 65
Street width is clearly defined in Pembroke College Dormitories by MLTW.



5.

There are many ways for stores, workshops and eating places to establish a connection with the street so that entering is continuous with the public path.

A - If the edge zone is made predominantly of glass, this allows views in.

B - A more engaging connection occurs when the physical edge zone is essentially open to the street. With sliding panels, shutters or garage doors, that provide protection when needed, sounds and smells are introduced as well as the ability to converse across territories.

C - If the edge zone is not only physically open but if some of the activity can move out and cross the street, then it is no longer a matter of moving alongside but actually through the

activities.

In order for it to maintain such a relationship, the street should be treated as a succession of outdoor rooms. These would be partly enclosed spaces, with enough of the qualities of a room to permit people to act as they do in rooms.

To make such outdoor 'rooms', low walls, trees, level changes and paving must in themselves or together form containers for sitting in or "backing up" to.

To make these outdoor rooms public, "the path to the building must itself become a 'place' that is partly inside the building and this place must contain the character of the inside."

If the ground, edges, curbs, walls or overhangs that define the building can get out and also define some of the street

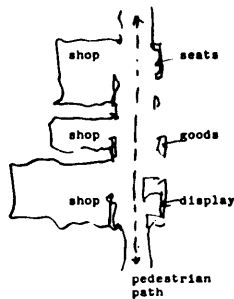

Figure 69

A visual connection is made with the street.

Figure 70

The edge is open to the street and one moves alongside the activity.

Figure 71

The edge is open and some of the activity straddles the path so that one is moving through the store,



70



69

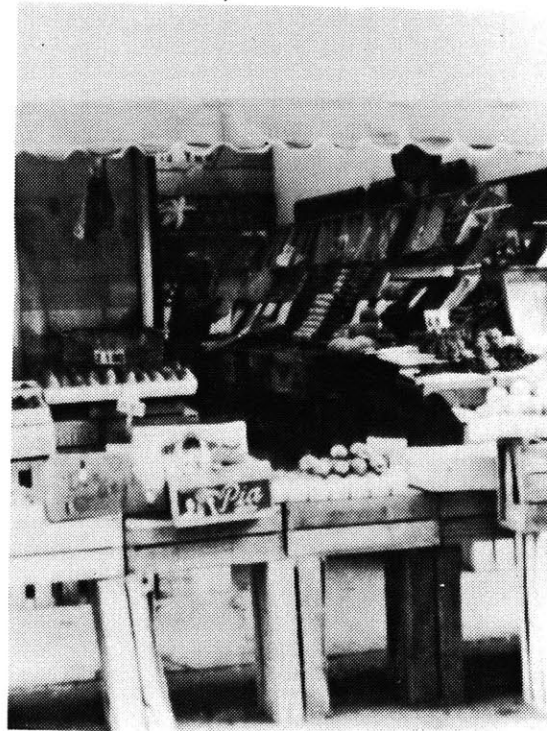

71

(or vice versa) then access will not be abrupt; the sense of entering will seem very much a part of the street.

"To establish this place as a territory which is also apart from the public world, it must be felt as an extension of the building interior."

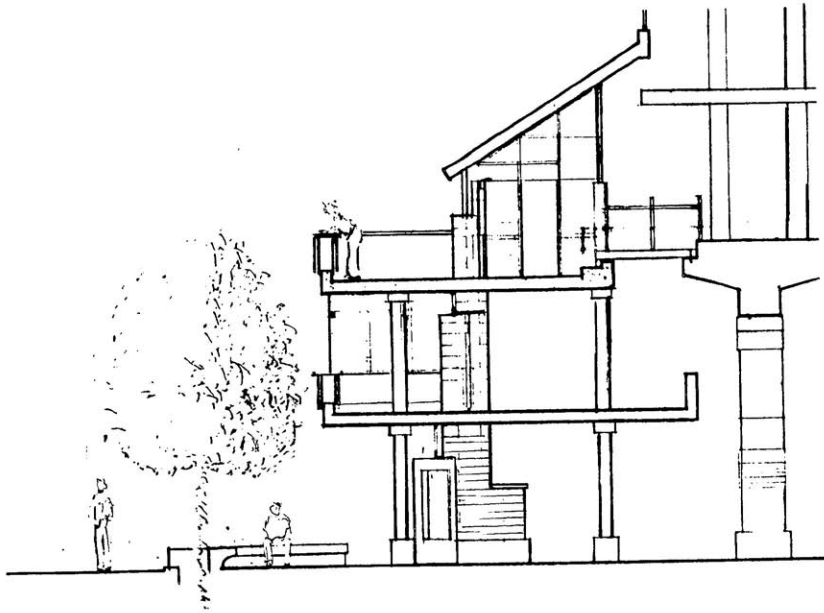

72

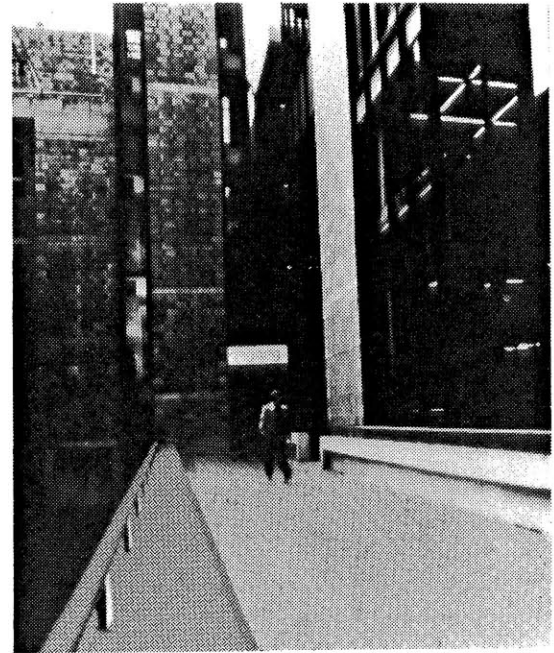

73

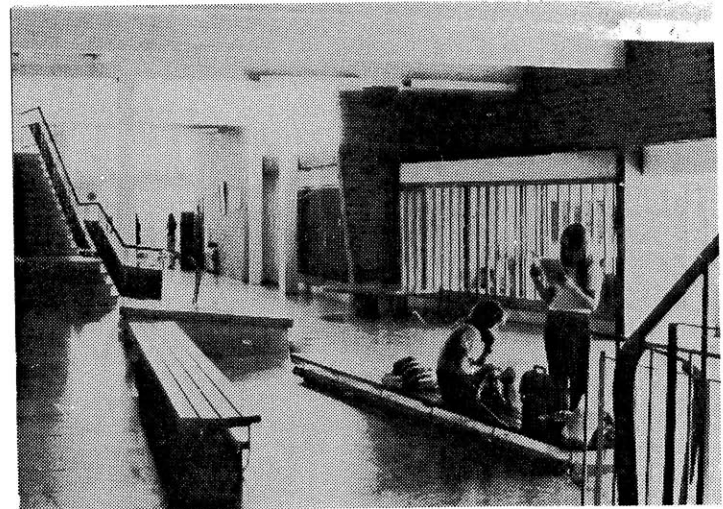

74

Figure 73

The curb that defines this street extends into the building and defines part of the lobby.

Figure 74

One bench provides a buffer from the 'street' and makes a more defined place for the bench behind it.

Figure 75

An outdoor room along the 'street'.



75

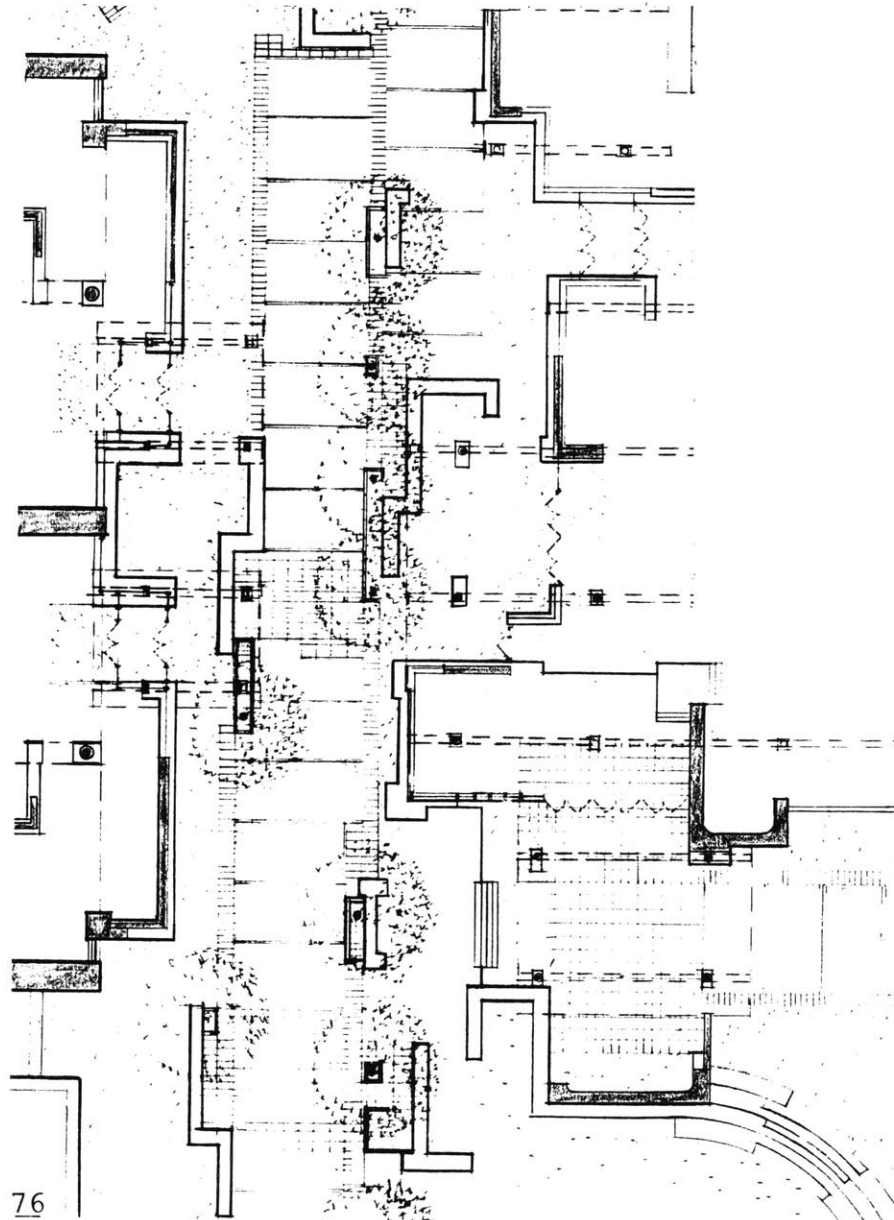

76

67

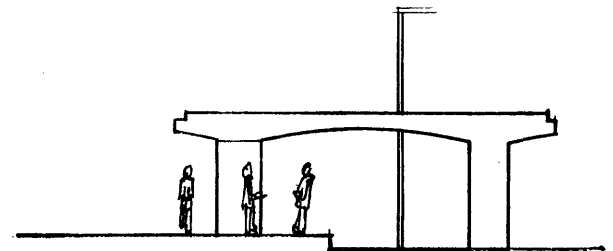
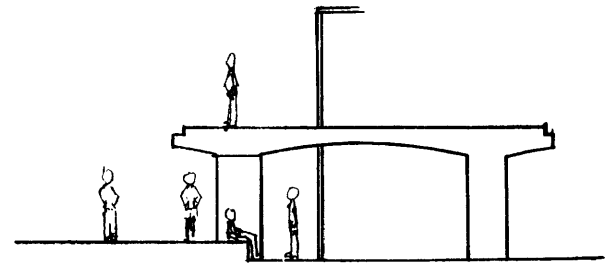
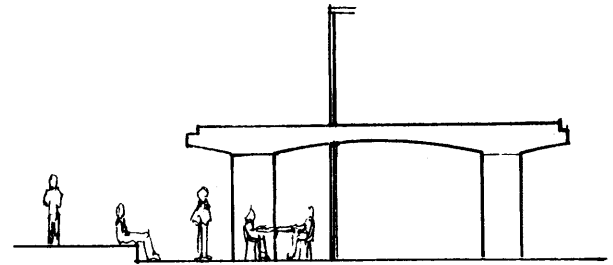

77

Figures 78 - 80

Outdoor rooms can be reinforced with display walls, places where the personality of a shop can get outside.



78



79



80

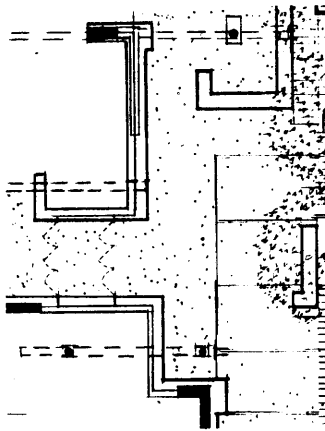
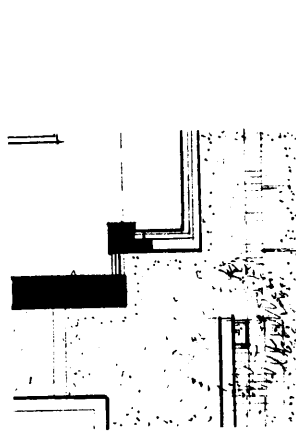
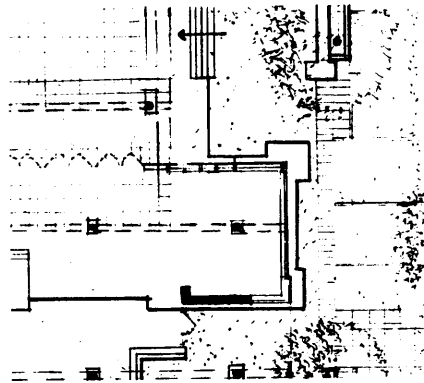
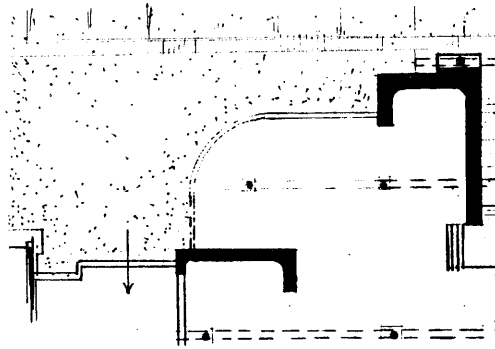

6.

Building corners, for certain uses, should be transparent at least at eye level along streets. This helps to make the turn more spatial. It provides a clue as to where you're going and alleviates collisions that may occur between two people coming from different directions around that corner. The more major the turn the more time should be available between seeing the turn and having time to decide whether or not to make it. In these cases, a larger region of the building edge should be transparent.

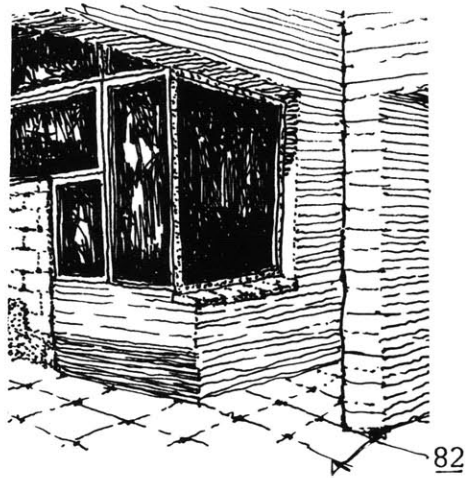

82



84

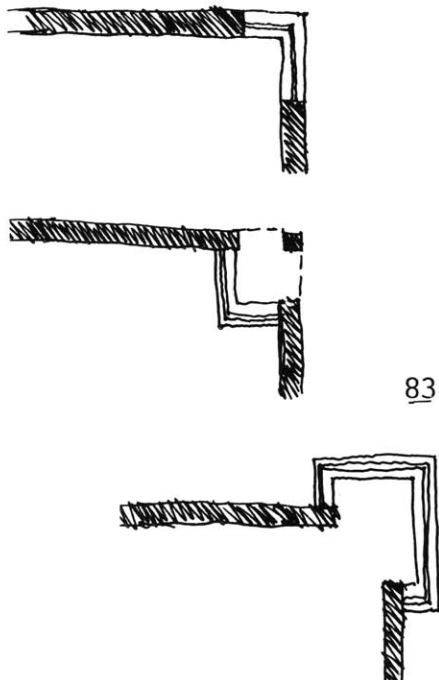

83

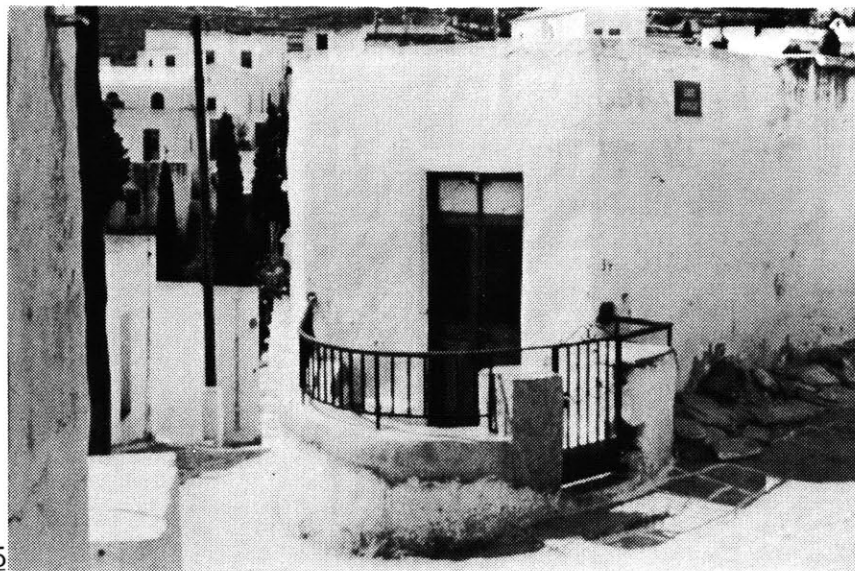

85

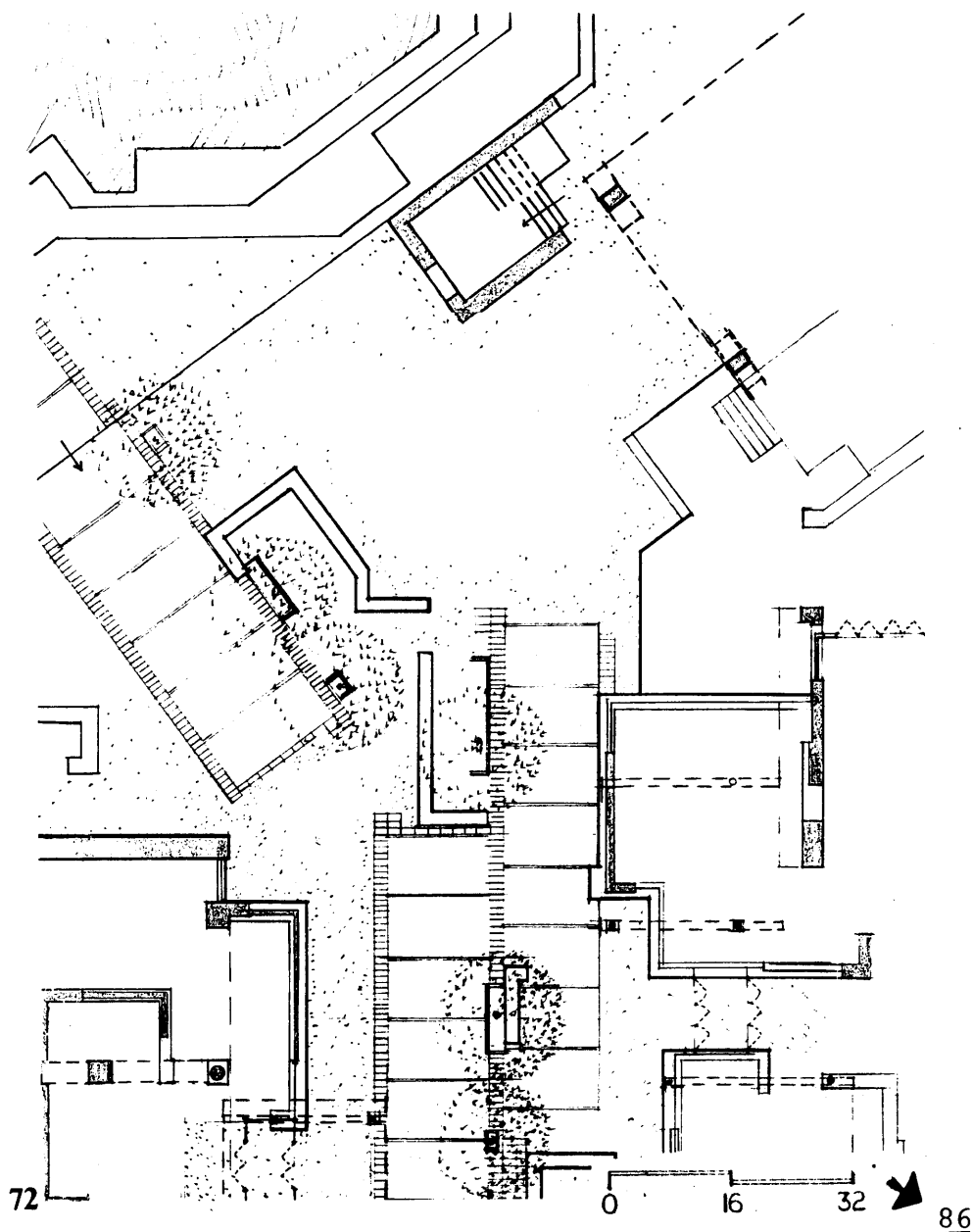

7.

When a major path branches off into two or more paths, continuity of direction, dimension, level and/or materials should be maintained between the initial main path and the main branching path. Secondary branching paths will have more clarity with a break in continuity. Attention is usually focused at points of decision. Therefore, the end of the initial path should be marked with a form that serves both as a focus and as an introduction to the other direction. It provides something to move around, similar to the way that a jutting rock interrupts the flow of a river.



87

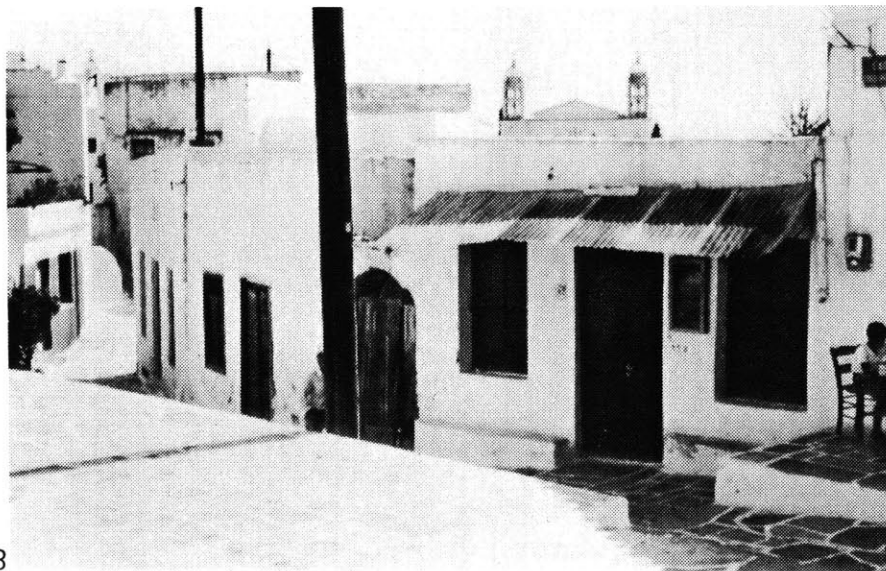

88

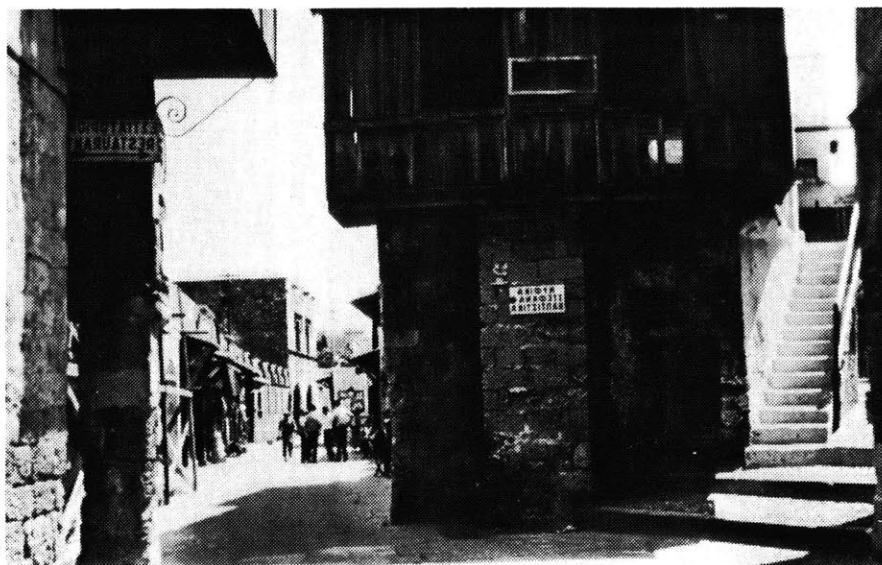

89

Trajan's Market, isometric drawing of the remains

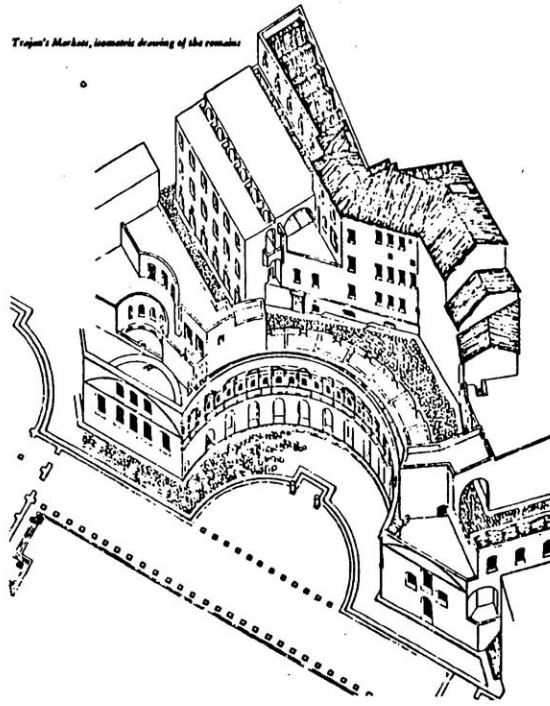

90

8.

In order for an outdoor room to successfully operate as a place, circulation must move around and not through it. For example, activity pockets, focus points at path intersections or branches, thrive when they don't block the shortest distance between two paths but occur just beyond.

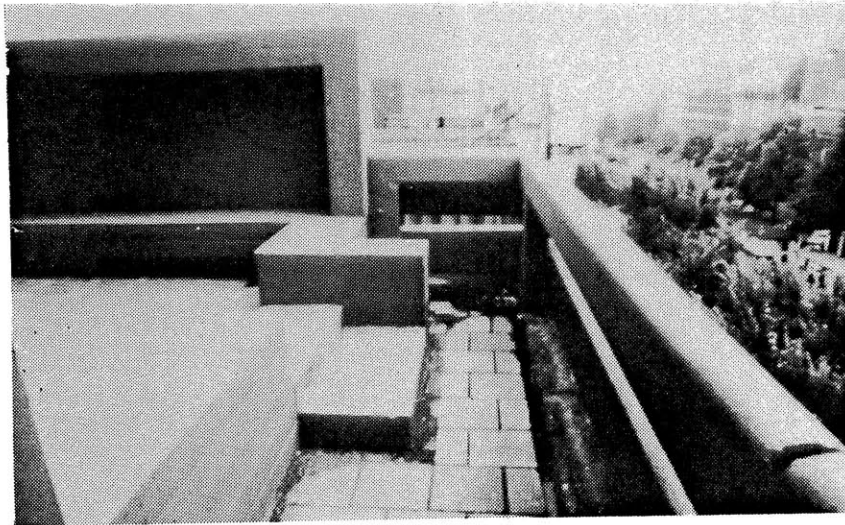

91



92

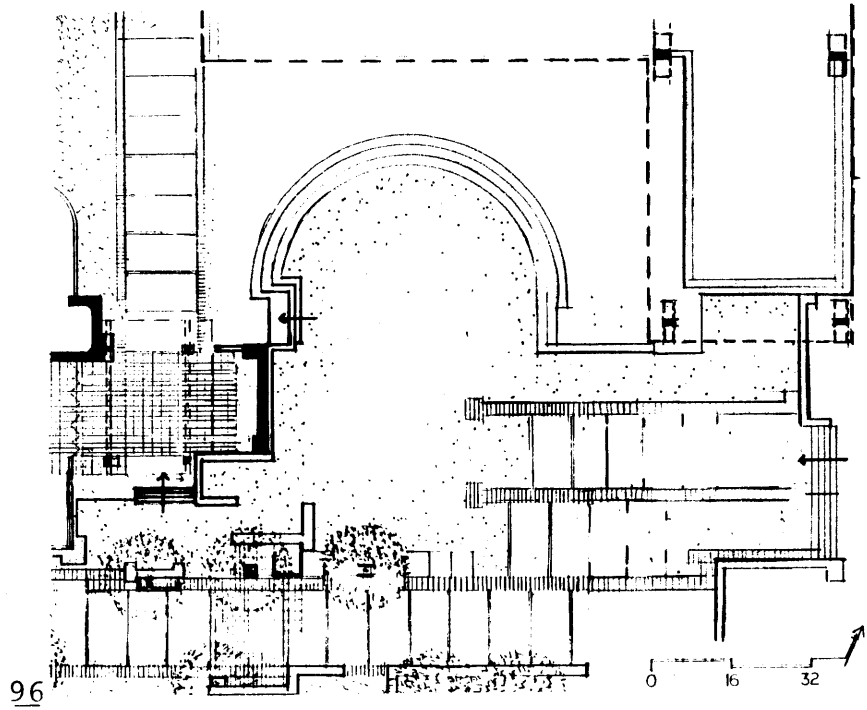
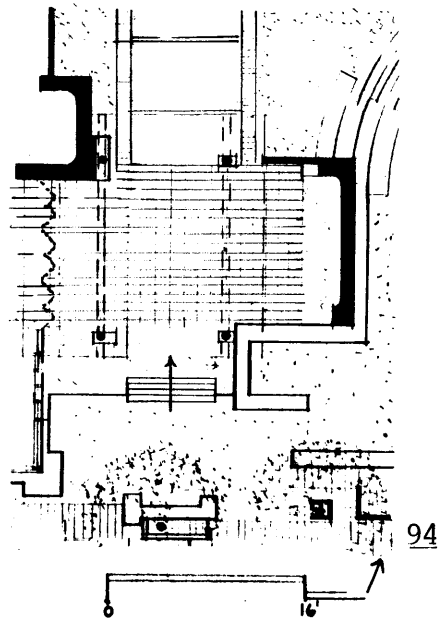
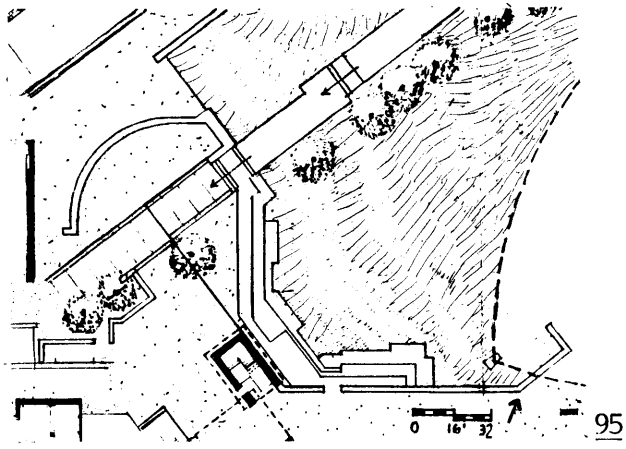
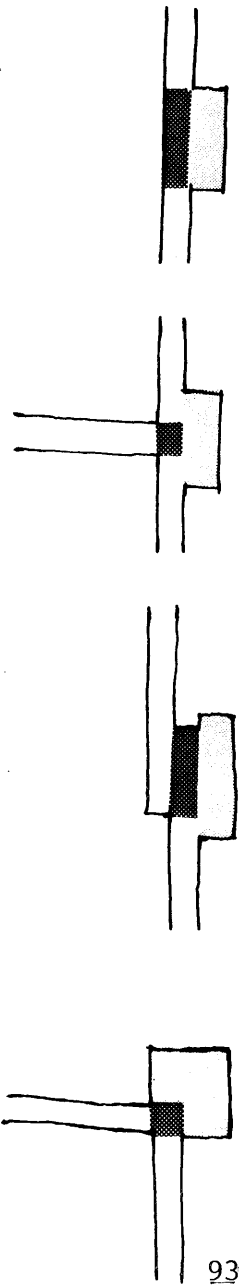

9.

Privacies off of public streets can be indicated with change in material, direction, relative size and/or level changes.



Figure 97

Although access to these steps maintains the public direction, their height and width in comparison to the public street suggest a more private domain.

Figure 98

There are two level changes. The first step can be accessed while moving in the public direction. Access to the second step is perpendicular to the street access. This and its contrasting relationship to 'street-size' steps makes it a more private gesture.

Figure 99

The change in direction and dimension are factors in indicating the private territory.

Figure 100

The stoop that is accessed parallel to the public direction is more public than its perpendicular counterpart.

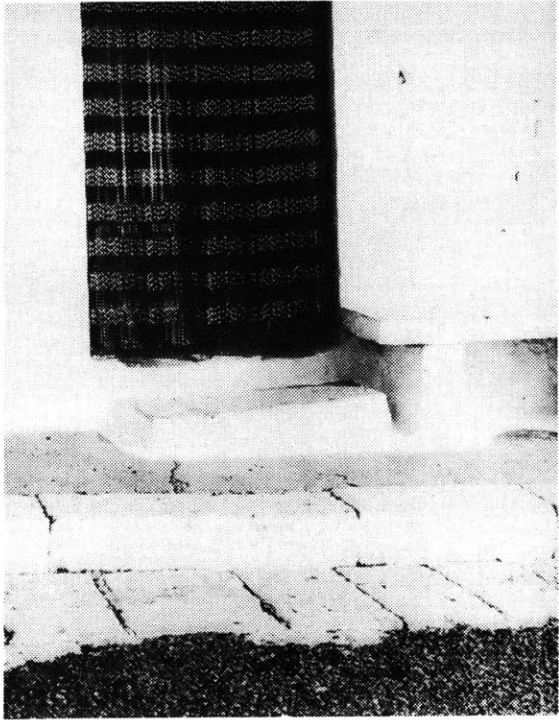

98

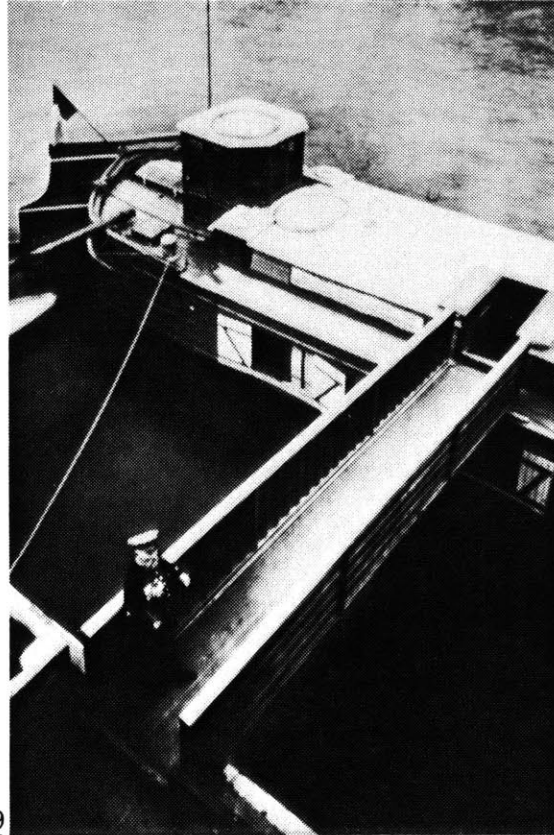

99

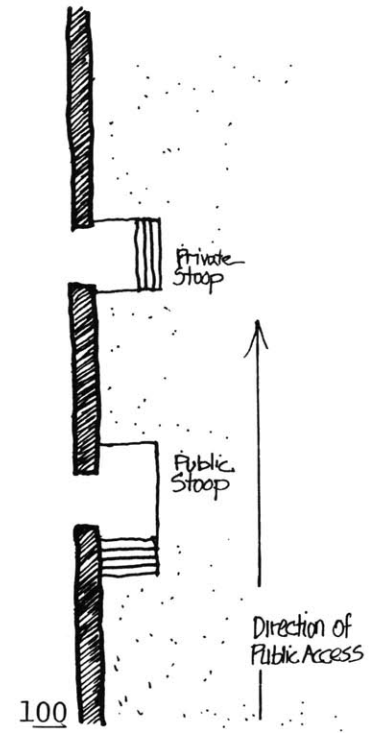

100

77

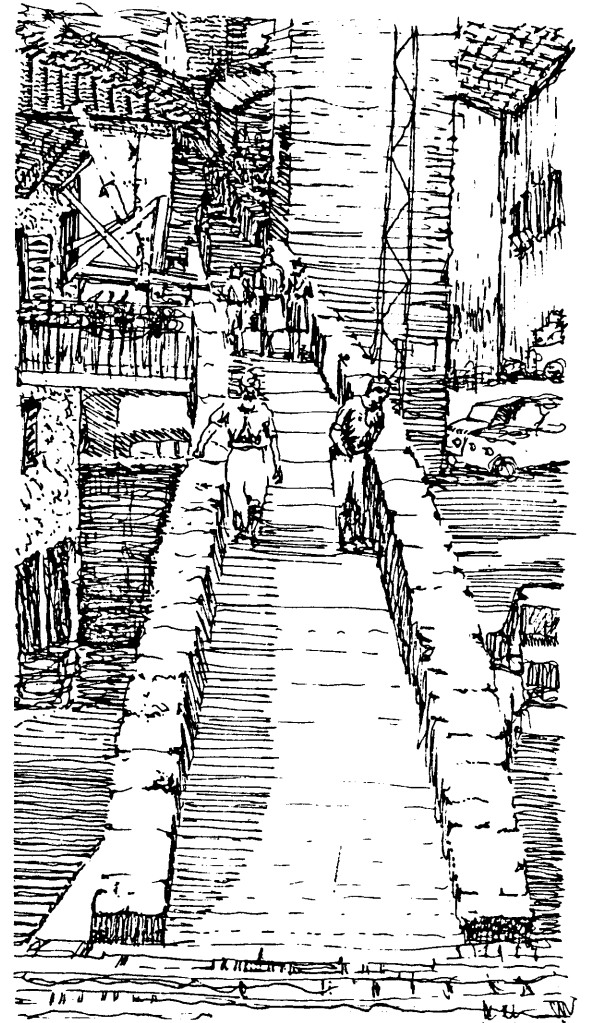

Bibliography

- Alexander, Christopher; Ishikawa, Sara; and Silverstein, Murray. A Pattern Language. N.Y.: Oxford University Press, 1977.
- Anderson, Stanford, ed.. On Streets. Cambridge, Ma.: MIT Press, 1978.
- Brambilla, Roberta; Longo, Gianni. For Pedestrians Only. N.Y., Watson-Guptill Publications, 1977.
- "Buildings Designed as 'Street.'" Architectural Record. July-September 1968.
- Cruikshank, Jeffrey, ed.. "Processes in Architecture: A Documentation of Six Examples," Plan. Cambridge, Ma., School of Architecture and Planning and the Committee on the Visual Arts, 1979, pp. 75-94.
- Cullen, Gordon. The Concise Townscape. N.Y.: Van Nostrand Reinhold Company, 1961.
- Dueker, Taylor True. "Decoration/Intensification/Collage as Definition/Form in Building...A Built-Form Exploration." M. Arch Thesis, MIT, September 1977.
- Goldfinger, Myron, "Repetitive Forms," Architectural Forum, March 1966.
- Gruzen and Partners, Mitchell and Giurgola, MIT East Campus Planners and Architects. East Campus Master Plan. Cambridge Ma., Wintry Press.
- Gutheim, Frederick, ed.. In the Cause of Architecture. Frank Lloyd Wright. N.Y., N.Y., McGraw-Hill, 1975.
- Jones, Peter Blundell. "Hans Scharoun." Monograph. London, G. Fraser, 1978.
- Jordy, William H. "Making the Ordinary Extraordinary." Progressive Architecture, January-March 1976, pp. 47-53.
- Kahler, Heinz. Hadrian Und Seine Villa Bei Tivoli. Berlin, Gebr. Mann, 1950.
- Lynch, Kevin. The Image of the City. Cambridge, Ma., MIT Press, 1962.
- Lynch, Kevin. Site Planning. Cambridge, Ma., MIT Press, 1960.
- "MLTW/Moore, Lyndon, Turnbull." Progressive Architecture. January-March 1970, pp. 130-135.
- Michaelides, Constantine E.. Hydra: A Greek Island Town. Cambridge, Ma., MIT Press, 1962.
- Nicholas, Elton P.. "The Public Framework." M. Arch Thesis, MIT, February 1977.

- Papadakis, Dr. Andreas. "Alvar Aalto." Monographs 4. N.Y., N.Y., Rizzoli International Publications, Inc., 1978.
- Rudofsky, Bernard. Behind the Picture Window. N.Y., Oxford University Press, 1955.
- Rudofsky, Bernard. Streets for People; a Primer for Americans. Garden City, N.Y., Doubleday, 1969.
- Santini, Pier Carlo, ed.. "Un opera di Carlo Scarpa il restauro di una antico palazzo veneziano." Zodiac 13. Ivrea, Italy, Ing. C. Olivetti and Co., 1964, pp. 26-59.
- Scharoun, Hans. Akademe Der Künste. 1 Berlin 21, Hanseatenweg 10., 1969.