

MIT Open Access Articles

Interline Photovoltaic (I-PV) power system - A novel concept of power flow control and management

The MIT Faculty has made this article openly available. **Please share** how this access benefits you. Your story matters.

Citation: Khadkikar, Vinod, and James L. Kirtley. "Interline Photovoltaic (I-PV) power system — A novel concept of power flow control and management." IEEE, 2011. 1-6.

As Published: <http://dx.doi.org/10.1109/PES.2011.6039459>

Publisher: Institute of Electrical and Electronics Engineers (IEEE)

Persistent URL: <http://hdl.handle.net/1721.1/72063>

Version: Author's final manuscript: final author's manuscript post peer review, without publisher's formatting or copy editing

Terms of use: Creative Commons Attribution-Noncommercial-Share Alike 3.0



Interline Photovoltaic (I-PV) Power System – A Novel Concept of Power Flow Control and Management

Vinod Khadkikar, *Member, IEEE*, and James L. Kirtley, Jr., *Fellow, IEEE*

Abstract—This paper presents a new system configuration for a large-scale Photovoltaic (PV) power system with multi-line transmission/distribution networks. A PV power plant is reconfigured in a way that two adjacent power system networks/feeders can be interconnected. The inverter modules in a PV power plant are configured such that the system is represented as a back to back inverter connected multi-line system, called as Interline-PV (I-PV) system. The proposed I-PV system then can be controlled adequately allowing the PV solar plant to function as a flexible AC transmission system (FACTS) device, such as, interline power flow controller (IPFC). With the proposed I-PV system both active and reactive power flow control and energy management in a multi-line system can be achieved. The I-PV system can have various applications, for example, to regulate the feeder voltages, load reactive power support, real power transfer from over power generation line to under loaded line, improve the overall system performance against dynamic disturbances (such as, power system damping) and so on. A simulation study is carried out to illustrate one of the capabilities and effectiveness of the proposed I-PV system.

Index Terms—Photovoltaic power generation, interline power system, active power control, reactive power control, voltage regulation, power management.

I. INTRODUCTION

RECENT technological developments have made it possible to generate power, in order of tens of mega-watts (MW) to hundreds of MWs, using renewable energy resources, such as, photovoltaic (PV) solar and wind turbines systems. However, as the penetration levels of these distributed generators (DG) continue to grow to the extent that it is affecting the normal operation of a power system [1-4]. The large-scale real power injection by DG systems at certain locations on power transmission/distribution networks can violate the power system constraints, such as, excessive feeder voltage rise [4]. Apart from this, the issues related with poor power quality, harmonics, proper active and reactive power management, etc. are becoming more prevalent [1-3].

The adequacy of generating capacity in a power system can be improved by interconnecting two or more power systems.

Better performance of power system can be achieved by controlling the flow of power in interconnected system. Alternately, flexible AC transmission system (FACTS) devices have been utilized to increase the power transfer capability of transmission systems and regulate the power flow over transmission lines. Some of the important FACTS devices can be listed as, thyristor controlled reactor (TCR), thyristor controlled series compensator (TCSC), static synchronous compensator (STATCOM), static synchronous series compensator (SSSC), unified power flow controller (UPFC), interline power flow controller (IPFC) and others [5-8].

Recently, PV solar plant inverters have been called on to perform additional tasks, such as current harmonic compensation, load reactive power support and voltage regulation [9-14]. This paper proposes a new system configuration that can be considered as a FACTS device, realized using existing inverters in a PV solar power plant. Generally, a large-scale PV solar power plant is constructed by connecting several smaller inverter – solar array units (order of few hundred kW up to 500 kW or more) in parallel. The idea here is to reconfigure these several units such that two or more transmission (or even distribution) lines can be interconnected using the PV solar plant inverters. The system configuration thus achieved is termed as Interline PV (I-PV) system. This configuration is similar in construction to the IPFC. However, in the I-PV system two or more transmission/distribution lines are connected though shunt connected back to back converters contrary to IPFC where they are connected in series with the lines.

The proposed I-PV system can be used to control the flow of active and reactive power in multi-line transmission networks, support leading or lagging reactive powers to different lines independently to regulate the line voltage, and so on. The I-PV system configuration could be an attractive solution especially during the period when PV solar power plant remains inactive, namely, late evening hours, throughout night hours and early morning hours. Furthermore, the concept of I-PV system can be extended during daytime hours providing further flexibility over control and regulation of real power generated by PV solar power station. In this paper the concept of interline PV system is introduced. A MATLAB/SIMULINK based study is carried to illustrate one of many capabilities of proposed I-PV system.

V. Khadkikar is with the Electric Power Engineering Program, Masdar Institute, Abu Dhabi, UAE (E-mail: vkhadkikar@masdar.ac.ae).

J. L. Kirtley, Jr. is with the Massachusetts Institute of Technology, Cambridge, MA 02139 USA (E-mail: kirtley@MIT.EDU)

II. PROPOSED INTERLINE-PV SYSTEM CONFIGURATION

Fig. 1 shows a general representation of PV solar power plant based distribution/transmission network system. A large-scale PV power plant, in the order of few MWs to few hundred MWs, is realized by installing an approximate number of the relatively smaller rating (200 kW to 500 kW) inverter modules. These inverter modules can be seen as small PV solar power generation units within a large-scale PV solar plant. Furthermore, two or more parallel connected modules are grouped together and connected to the main grid (such as, Feeder-1 in Fig. 1) using a step-up transformer. For example, eight 250 kVA (or four 500 kVA) inverter modules are

grouped together (Inv-1 in Fig. 1) and connected to a 2 MVA step-up transformer (T-1 in Fig. 1). Each inverter module may be realized as three-phase PWM voltage source inverter as depicted in Fig.1. The point at which the PV solar plant is connected to Feeder-1 is referred as point of common coupling/connection (PCC). It is considered that a second network (Feeder-2 in Fig. 1) is available adjacent to the PV solar plant based transmission/distribution network. This second network/line can be originated from the same generation station or can be a complete different power source with different voltage ratings. Such a situation can occur in an actual practical system and is not completely hypothetical.

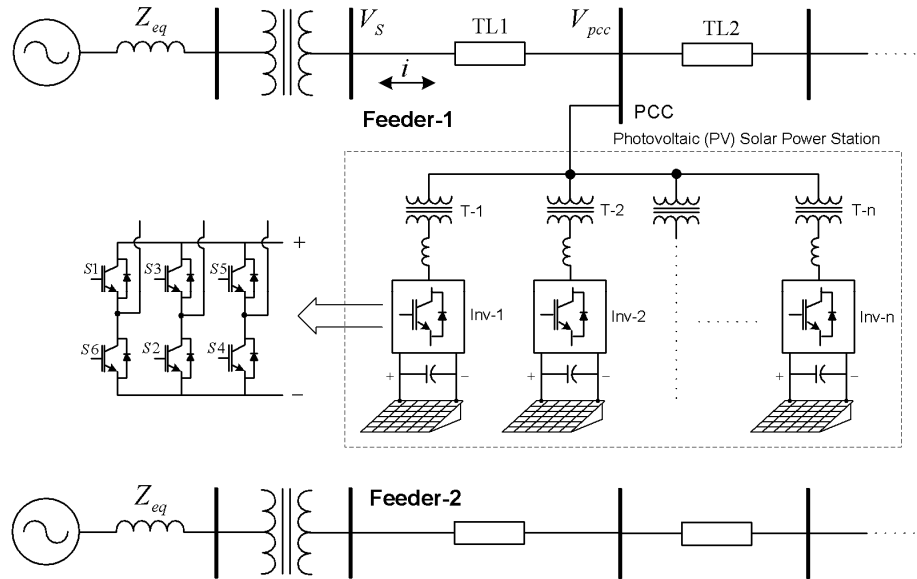

Fig.1 A photovoltaic power system.

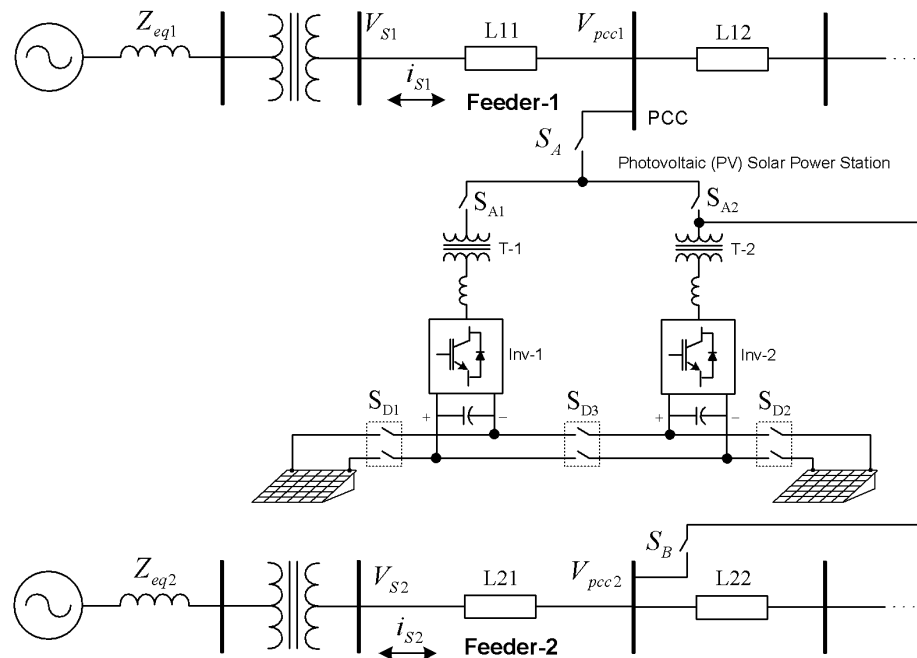

Fig.2 Proposed Interline PV (I-PV) system configuration.

The above discussed system, with few modifications, is reconfigured in Fig. 2 to form the proposed interline PV (I-PV) system, i.e. to connect two feeders with each other through solar plant inverter modules. This kind of configuration is feasible and could be more appropriate during nighttime hours when PV solar power station remains inactive producing no real power.

It is important to mention here that the current grid interconnection of renewable energy system standards, such as IEEE 1457 [15], does not allow the DG system owner to perform tasks other than injection of real power to the grid. These are not technical challenges and a mutual agreement between PV solar plant owner and transmission utility may be feasible. This paper address only the technical aspects of using a PV solar power plant as a versatile FACTS device and possible benefits achieved from such a kind of control.

For simplicity, only two inverter units (*Inv-1* and *Inv-2*) are considered. In Fig. 2, S_A and S_B represent the main switches through which the PV power plant is connected to feeders-1 and -2. S_{A1} and S_{A2} represent the secondary switches to isolate an individual inverter unit within the PV power plant. The DC side switches, S_{D1} and S_{D2} , can be used to disconnect the PV solar arrays from the inverter units *Inv-1* and *Inv-2*, respectively. The switch S_{D3} represents an additional switch to connect two inverter units back to back with each other. The switches S_A , S_{A1} , S_{A2} , S_{D1} and S_{D2} may be presented in a typical PV solar power plant system. Thus, to reconfigure a PV solar plant into proposed interline PV system following additional components may be required:

- DC bus network at the DC side of the solar system to form a common DC link between inverter units: corresponding line connections and the switch(s) S_{D3} .
- Connecting lines between the inverter units and adjacent feeder, and switch S_B .

Furthermore, multiple switches S_{D3} along with the necessary connecting lines will be required based on the number of inverter modules utilized to form the proposed interline system. Fig. 3 shows the generalized representation of the proposed I-PV system. The switches S_A , S_B , S_{A1} and S_{D3} are closed and S_{A2} , S_{D1} and S_{D2} are opened to realize the I-PV system configuration in Fig. 3.

The key functionalities that can be achieved using the proposed I-PV system are outlined below:

- Reactive power support to both the feeders for voltage regulation and/or load reactive power compensation or combination – simultaneously and independent control over each feeder is possible.
- Dynamic active and reactive power support to the feeder to improve the power system damping.
- Active power flow control and management between multi-line feeders.
- Optimal utilization of existing PV solar power station inverters, especially during nighttime hours to enhance the overall power system performance.

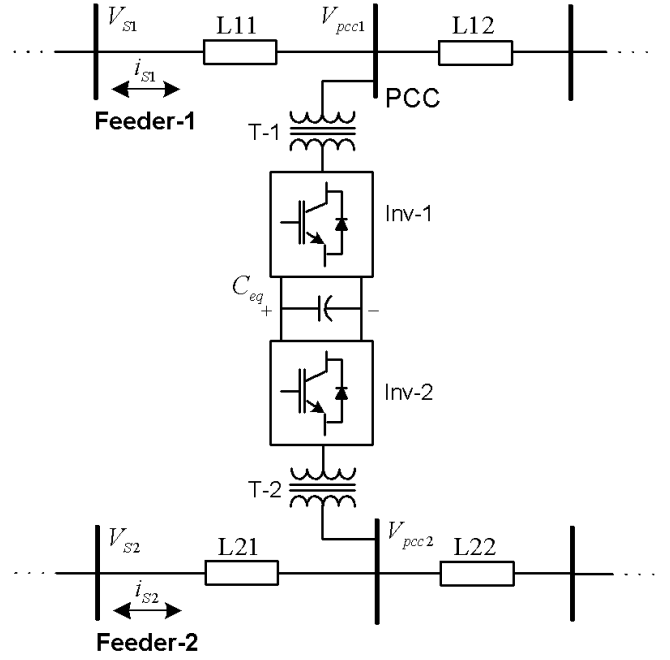

Fig.3 General single-line representation of proposed interline PV system.

III. SIMULATION STUDY

In this section, a simulation study based on proposed I-PV system is discussed to illustrate the feasibility of realizing such a system configuration and its effectiveness in improving the overall power system performance.

A. System under consideration

Fig. 4 shows a MATLAB/SIMULINK based simulation model for the proposed interline PV system. For simplicity, both the feeder voltage levels are considered as 27 kV. The loads on the feeders are considered to be located at the feeder ends and are represented as equivalent PQ loads. The loads on the feeder-1 and feeder-2 have different P and Q values and are represented as Load-1 and Load-2. The voltages, V_{pcc1} and V_{pcc2} , represent measured voltages at PCC on feeder-1 and feeder-2, respectively. The real and reactive powers delivery by the *Inv-1* and *Inv-2* are denoted as, P_{Inv1} & Q_{Inv1} , and P_{Inv2} & Q_{Inv2} .

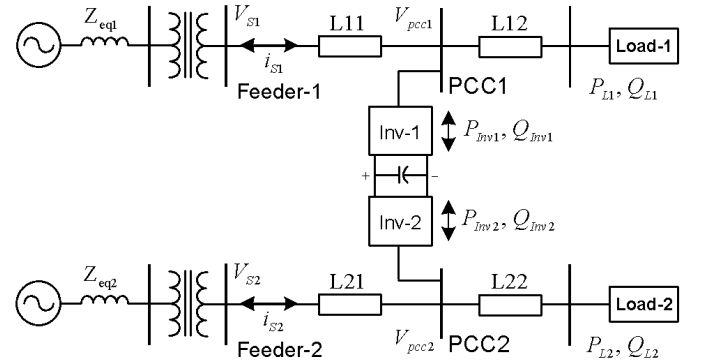

Fig. 4 Simulation study interline PV system diagram.

Q_{Inv2} . The leading reactive powers supported by Inv-1 and Inv-2 are shown as negative quantities, whereas, the positive values of reactive powers represent lagging reactive power support.

In this paper, the preliminary results of above discussed system are given. Authors expect to conduct a thorough study on the possible benefits and limitations of proposed interline PV system. Nevertheless, to demonstrate one of the capabilities of interline PV system following interesting study is conducted where it is assumed that the PV power station is not generating any real power (nighttime hours):

- Inv-1 is utilized to regulate the PCC voltage on the Feeder-1, and,
- simultaneously, the Inv-2 is controlled to support the load reactive power demand on the Feeder-2.

B. Control of Interline PV System

To achieve above mentioned control objectives, both the inverter modules are controlled as independent sources of reactive powers. The overall control diagram for inverter units Inv-1 and Inv-2 are illustrated in Fig. 5 and 6.

Fig. 5 shows the controller for the PV inverter unit Inv-1, where it is controlled as a STATCOM to regulate the feeder-1 PCC voltage. A phase locked loop (PLL) maintains the synchronization with the feeder-1. A PI control is used to regulate the PCC1 voltage. Furthermore, the Inv-1 is also controlled to maintain a self-supporting DC bus voltage across the interline PV system capacitor. This self-supporting DC bus ensures the desired performance from the system during night hours. The generated reference signals, $i_{Inv1,abc}^*$, are compared with actual Inv-1 currents to perform PWM operation (not shown in Fig. 5). The second inverter unit, Inv-2, is controlled to compensate the load reactive power (Q_{L2}) on the feeder-2. The control algorithm to extract the load reactive power demand is based on the single-phase $p-q$ theory and is given in detail in reference [16].

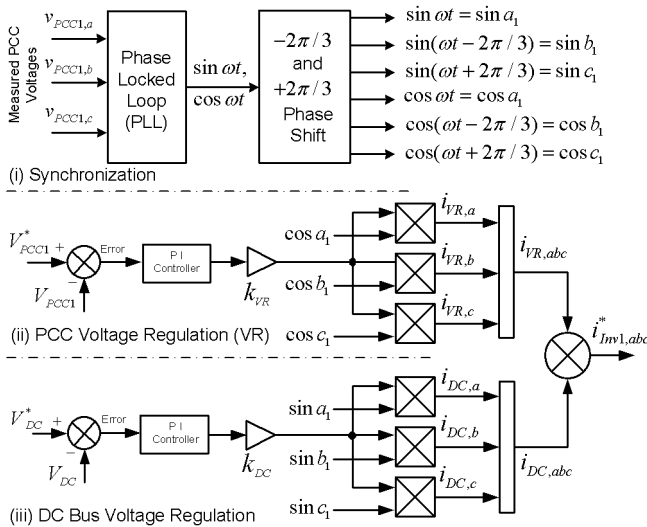

Fig. 5 Controller for inverter unit Inv-1 to regulate PCC1 voltage and to maintain a self-supporting DC bus voltage.

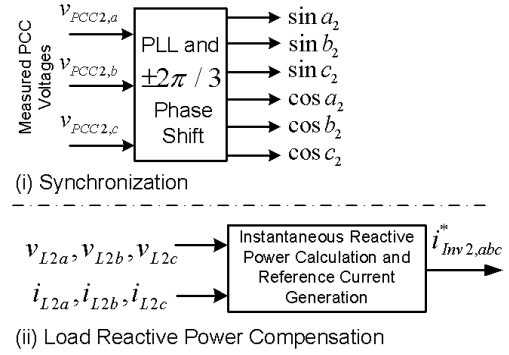

Fig. 6 Controller for inverter unit Inv-2 to compensate load reactive power.

C. Simulation Results

The simulation results for the above discussed control objectives are given in Fig. 7 to Fig. 9. All simulation results are expressed in per unit (pu) with base values of 10 MVA and 27 kV. The simulated system data is mentioned in Appendix-I. Following are the important timelines:

t_a : Inv-1 is turned ON, it starts regulating voltage at PCC, load on the feeder-1 = 8MW + 3.5 MVAR

t_b : load on the feeder-1 changed from 8MW + 3.5MVAR to 3MW + 1.5MVAR.

t_c : Inv-2 is turned ON, it starts compensating the load reacting power, a constant load on the feeder 2: 11MW + 7MVAR.

Fig. 7 gives the performance of the proposed interline PV system where Inv-1 is controlled to regulate the PCC voltage (V_{pcc1}) on the feeder-1. In Fig. 7 (a), V_{pcc1} and V'_{pcc1} represent the PCC voltages before and after compensations, respectively. As noticed, the PCC voltage of uncompensated feeder-1 is 0.941 pu until time 1.25 sec and 0.974 pu thereafter when the load is reduced. The improved profile of PCC voltage, when the PV solar plant Inv-1 is controlled as I-PV system, shows the improvement from 0.941 pu to 0.98 pu (heavy loading) and from 0.974 pu to 0.997 pu (reduced loading). The reactive power injected by Inv-1 to achieve the PCC voltage regulation is given Fig. 7 (b), plot-3. Note that the active power consumed by the Inv-1 is almost zero. The corresponding active and reactive power flow at PCC is also given in Fig. 7 (b), plot-2.

While Inv-1 is regulating the PCC voltage on Feeder-1, at time $t_c=1.5 sec$, the second inverter unit (Inv-2) is turned ON. The simulation results for PCC voltages and different active and reactive power flow are given in Fig. 8 (a) and (b). Thus, after 1.5 sec , both the inverter units of interline PV system operate simultaneously tackling different issues on two separate feeders. The Inv-2 supports the reactive power demanded by the inductive loads on the feeder-2 [Fig. 8, (b), plot-3). As a result, the reactive power drawn from the grid side is achieved as zero which can be noticed from Fig. 8 (b), plot-2. In other words, at the PCC a unity power factor operation is maintained. The profile of self-supporting DC voltage between two back to back connected inverter units is depicted in Fig. 9.

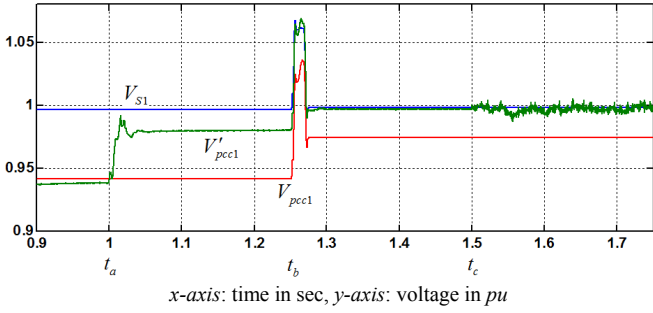

(a) Feeder-1 voltage profiles

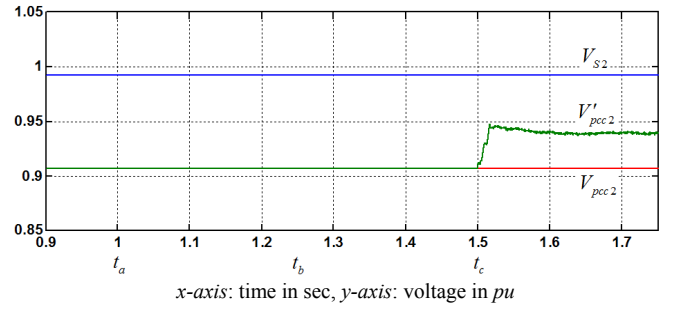

(a) Feeder-1 voltage profiles

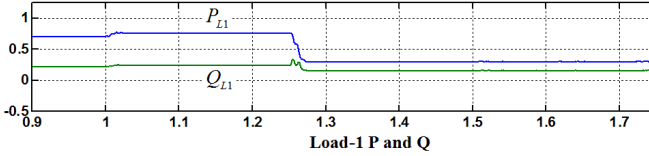

Load-1 P and Q

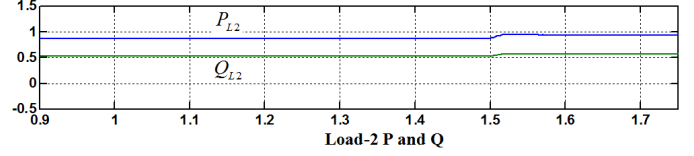

Load-2 P and Q

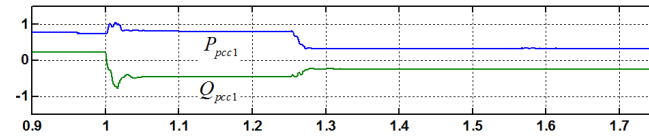

PCC-1 P and Q

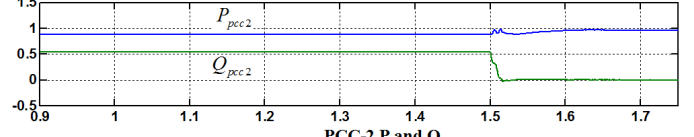

PCC-2 P and Q

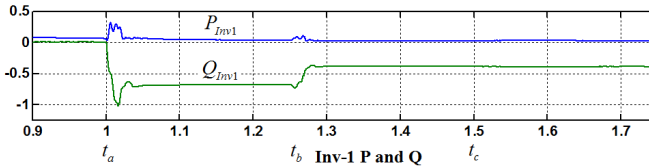

Inv-1 P and Q

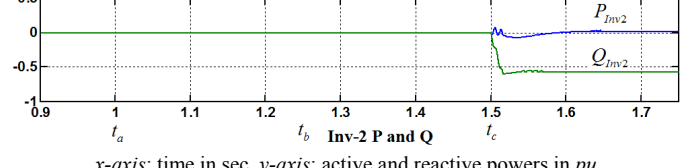

Inv-2 P and Q

x-axis: time in sec, y-axis: active and reactive powers in pu

x-axis: time in sec, y-axis: active and reactive powers in pu

(b) Active and Reactive power flow on the Feeder-1

(b) Active and Reactive power flow on the Feeder-1

Fig. 7 Feeder-1 performance with interline PV system.

Fig. 8 Feeder-2 performance with interline PV system.

IV. CONCLUSION

A new concept of using a PV solar power plant as interline PV system is introduced in this paper. As the name suggests, the interline PV system interconnects two (possibly more) transmission/distribution lines by reconfiguring existing PV solar plant inverters. This newly developed system thus can act as a FACTS device providing a flexible control over both active and reactive powers on multiple lines simultaneously. The interline PV system can be implemented during night hours when PV solar plant produces no real power. The configuration can possibly be realized during daytime hours too. The interline PV system can be used to regulate the transmission/distribution line voltages, to support inductive load VAR requirements, to improve the system performance during dynamic disturbances, manage real power flow between two or more interconnected lines and so on.

A MATLAB/SIMULINK based case study is discussed in the paper to demonstrate the control concept of interline PV system. A detailed study however is essential and authors expect to conduct a thorough analysis and in-depth study in the near future.

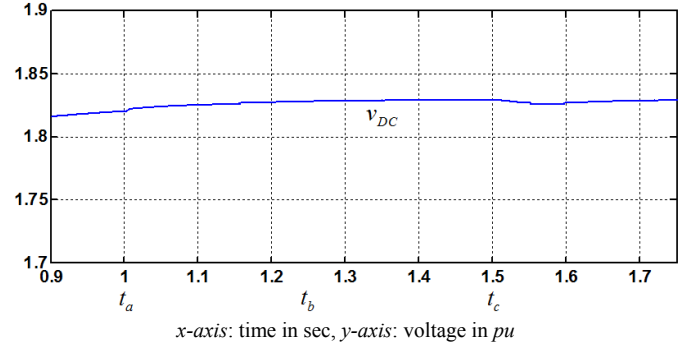

Fig. 9 Self-supporting DC bus voltage profile

V. ACKNOWLEDGMENT

This work is supported by Masdar Institute under MIT – Masdar Institute joint research project grant.

VI. APPENDIX-I

Feeders-1 and -2 system voltage level, $V_{S1}=V_{S2}=27kV$.
 Line parameters: $0.4 + j 0.5 / km$
 Line lengths: $L11=L21=10 km$, $L12=2.5 km$, $L22=1.5 km$
 Load on Feeder-1: heavy load = $8MW + 3.5MVAR$, light load = $3MW + 1.5MVAR$
 Load on Feeder-2: $11MW + 7MVAR$

VII. REFERENCES

- [1] R. A. Walling, R. Saint, R. C. Dugan, J. Burke, and L. A. Kojovic, "Summary of Distributed Resources Impact on Power Delivery Systems", *IEEE Trans on Power Delivery*, vol.23, no.3, pp.1636-1644, July 2008.
- [2] N. D. Hatzargyriou, and A. P. Meliopoulos, "Distributed energy sources: technical challenges", *Proc. IEEE PES Winter Meeting*, 2002, pp. 1017-1022.
- [3] T. E. McDermott, and R. C. Dugan, "PQ, reliability and DG", *IEEE Industry Applications Magazine*, vol.9, no.5, pp. 17-23, Sept.-Oct. 2003.
- [4] C. L. Masters, "Voltage rise: the big issue when connecting embedded generation to long 11 kV overhead lines", *Power Engineering Journal*, vol.16, no.1, pp.5-12, Feb 2002.
- [5] N. G. Hingorani, and L. Gyugyi, *Understanding FACTS: Concepts and Technology of Flexible AC Transmission Systems*, New York: Institute of Electrical and Electronics Engineers, 2000, 432p.
- [6] L. Gyugyi, K. K. Sen, and C. D. Schauder, "The interline power flow controller concept: a new approach to power flow management in transmission systems," *IEEE Trans on Power Delivery*, vol.14, no.3, pp.1115-1123, Jul 1999.
- [7] V. Diez-Valencia, U. D. Annakkage, A. M. Gole, P. Demchenko, and D. Jacobson, "Interline power flow controller (IPFC) steady state operation," IEEE Electrical and Computer Engineering Canadian Conference (CCECE), 2002. pp. 280- 284.
- [8] F. Aminifar, M. Fotuhi-Firuzabad, R. Nasiri, and A. Khodaei, "Effect of Interline Power Flow Controller (IPFC) on interconnected power systems adequacy," IEEE Power and Energy Conference, 2008, pp.1358-1363.
- [9] K. Sung-Hun, L. Seong-Ryong, H. Dehbonei and C. V. Nayar, "A Grid-Connected Photovoltaic System with Direct Coupled Power Quality Control," *Proc. IEEE Indust. Electron. Conf.*, 6-10 Nov. 2006, pp.5203-5208.
- [10] P. Flores, J. Dixon, M. Ortuzar, R. Carmi, P. Barriuso and L. Moran, "Static Var Compensator and Active Power Filter With Power Injection Capability, Using 27-Level Inverters and Photovoltaic Cells," *IEEE Trans on Indust. Electron.*, vol.56, no.1, pp.130-138, Jan. 2009.
- [11] W. Libo, Z. Zhengming, and L. Jianzheng, "A Single-Stage Three-Phase Grid-Connected Photovoltaic System With Modified MPPT Method and Reactive Power Compensation," *IEEE Trans on Energy Conver.*, vol.22, no.4, pp.881-886, Dec. 2007.
- [12] T. F. Wu, H. S. Nien, C. L. Shen, and T. M. Chen, "A single-phase inverter system for PV power injection and active power filtering with nonlinear inductor consideration," *IEEE Trans on Industry Appl.*, vol.41, no.4, pp. 1075-1083, July-Aug. 2005.
- [13] L. J. Borle, M. S. Dymond, and C. V. Nayar, "Development and testing of a 20-kW grid interactive photovoltaic power conditioning system in Western Australia," *IEEE Trans on Industry Appl.*, vol.33, no.2, pp.502-508, Mar/Apr 1997.
- [14] R. K. Varma, V. Khadkikar, and R. Seethapathy, "Nighttime Application of PV Solar Farm as STATCOM to Regulate Grid Voltage", in *IEEE Transactions on Energy Conversion*, vol.24, no.4, pp.983-985, Dec. 2009.
- [15] IEEE P1547 Standard for Distributed Resources Interconnected With Electric Power Systems, IEEE P1547 std., Sept. 2002.
- [16] V. Khadkikar, A. Chandra, and B. N. Singh, "Generalised single-phase p-q theory for active power filtering: simulation and DSP-based experimental investigation", *IET Power Electron.*, vol.2, no.1, pp.67-78, Jan. 2009.

VIII. BIOGRAPHIES



Electrical Engineering.

From December 2008 to March 2010, he was a Postdoctoral Fellow at the University of Western Ontario, London, ON, Canada. Since April 2010 he is an Assistant Professor at Masdar Institute, Abu Dhabi, UAE. Currently, he is a visiting faculty at Massachusetts Institute of Technology (M.I.T.), Cambridge, MA, USA. His research interests include power quality enhancement, active power filters, applications of power electronics in renewable energy resources and grid interconnection issues.



James L. Kirtley, Jr. (F'91) received the Ph.D. degree in electrical engineering from the Massachusetts Institute of Technology (MIT), Cambridge, in 1971. He has been a member of the faculty of the Department of Electrical Engineering and Computer Science at MIT since 1971, where he is currently Professor of Electrical Engineering. He was also an Electrical Engineer with the Large Steam Turbine Generator at General Electric, General Manager and Chief Scientist with SatCon Technology Corporation, and was Gastdozent at the Swiss Federal Institute of Technology. He is a specialist in electric machinery and electric power systems.

Dr. Kirtley was Editor-in-Chief of the IEEE TRANSACTIONS ON ENERGY CONVERSION from 1998 to 2006 and continues to serve as Editor for that journal and as a member of the Editorial Board of the journal *Electric Power Components and Systems*. He is a member of the U.S. National Academy of Engineering. He was awarded the Nikola Tesla prize in 2002 and the IEEE Third Millennium medal. He is a Registered Professional Engineer in Massachusetts.